



user manual

Built-In Electric Oven

EOB32000

We were thinking of you
when we made this product

Welcome to the world of Electrolux

Thank you for choosing a first class product from Electrolux, which hopefully will provide you with lots of pleasure in the future. The Electrolux ambition is to offer a wide variety of quality products that make your life more comfortable. You will find some examples on the cover in this manual. Please take a few minutes to study this manual so that you can take advantage of the benefits of your new machine. We promise that it will provide a superior User Experience delivering Ease-of-Mind. Good luck!

Contents

Safety instructions	5
Description of the Appliance	7
Before Using for the first time	10
Using the Oven	12
Uses, Tables and Tips	21
Cleaning and Care	33
What to do if ...	43
Installation Instructions	44
Disposal	47
Guarantee/Customer Service	48
Service	50

The following symbols are used in this user manual:



Important information concerning your personal safety and information on how to avoid damaging the appliance.



General information and tips



Environmental information



Safety instructions

Electrical safety

- This appliance must be only connected by a **registered electrician**.
- In the event of a fault or damage to the appliance: Take the fuses out or switch off.
- **Repairs** to the appliance must only be carried out by **qualified service engineers**. Considerable danger may result from improper repairs. If repairs become necessary, please contact our Customer Services or your dealer.

Child Safety

- Never leave children unsupervised when the appliance is in use.

Safety whilst using

- People (including children) who, because of their physical, sensory or mental capabilities or their inexperience or ignorance are not able to use the device safely, should not use this device without supervision or instruction by a responsible person.
- This appliance is intended to be used for cooking, roasting and baking food in the home.
- Take care when connecting electric appliances to sockets nearby. Do **not** allow connecting leads to come into contact with or to catch beneath the hot oven door.
- **Warning: Risk of burns!** The interior of the oven becomes hot during use.
- Using ingredients containing alcohol in the oven may create an alcohol-air mixture that is easily ignited. In this case, open the door carefully. Do not have embers, sparks or naked flames in the vicinity when opening the door.



Information on acrylamides

According to the latest scientific knowledge, intensive browning of food, especially in products containing starch, can constitute a health risk due to acrylamides. Therefore we recommend cooking at the lowest possible temperatures and not browning foods too much.

How to avoid damage to the appliance

- Do not line the oven with aluminium foil and do not place baking trays, pots, etc. on the oven floor, as the heat that builds up will damage the oven enamel.
- Fruit juices dripping from the baking tray will leave stains, which you will not be able to remove. For very moist cakes, use a deep tray.
- Do not put any strain on the oven door when open.
- Never pour water directly into the oven when it is hot. This could cause damage to or discolouration of the enamel.
- Rough handling, especially around the edges of the front panel, can cause the glass to break.
- Do not store any flammable materials inside the oven. These could ignite when the oven is switched on.
- Do not store any moist foods inside the oven. This could damage the oven enamel.
- After switching off the cooling fan, do not keep uncovered dishes in the oven. Moisture may condense in the oven interior or on the glass doors and may get into the units.



Note on enamel coating

Changes in the colour of the oven's enamel coating as a result of use do not affect the appliance's suitability for normal and correct use. They therefore do not constitute a defect in the sense of the warranty law.

Description of the Appliance

General Overview

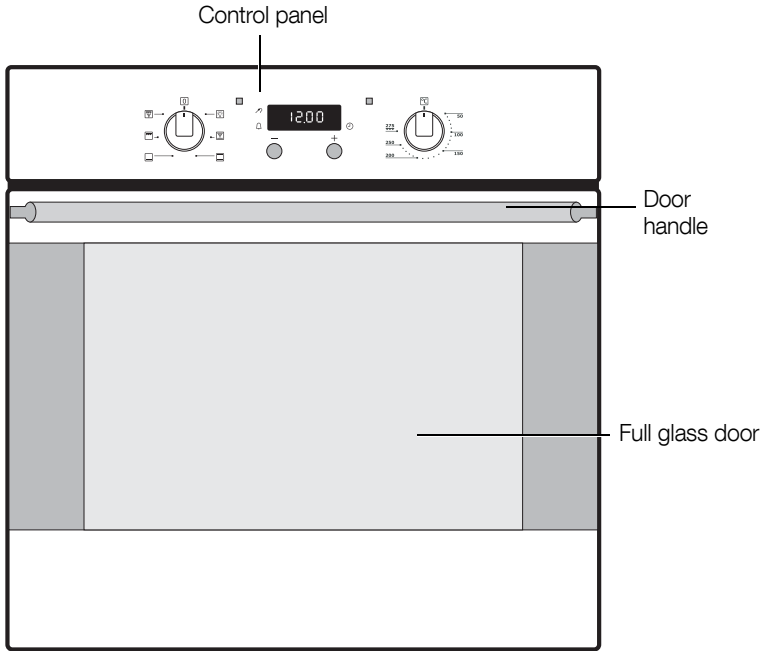

Control Panel

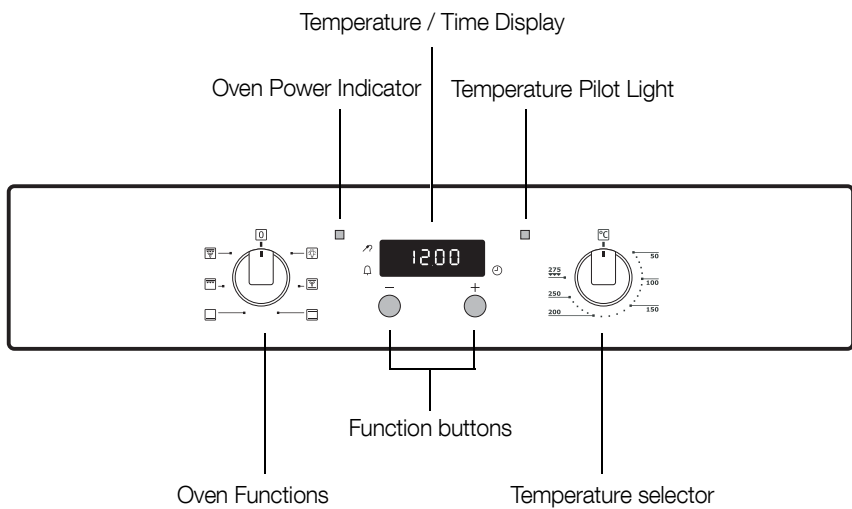

Oven Features

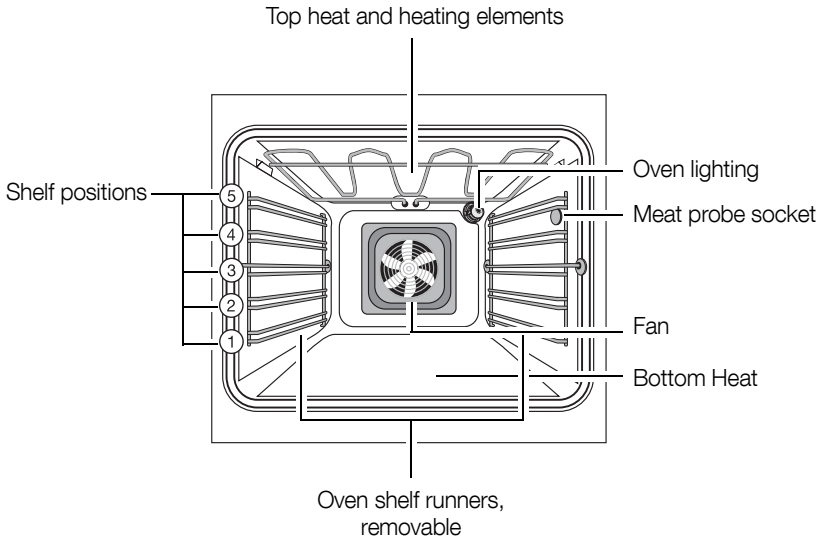

Oven accessories

Oven shelf

For cookware, cake tins, roasts and grilled foods.

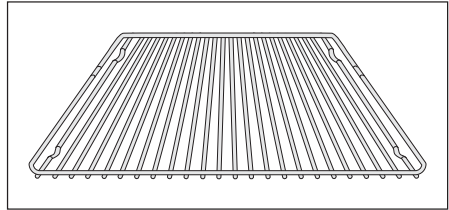

Baking tray

For cakes and biscuits.

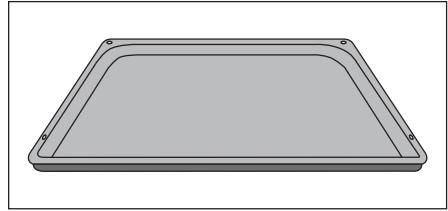

Roasting Pan

For baking and roasting or as a pan for collecting fat.

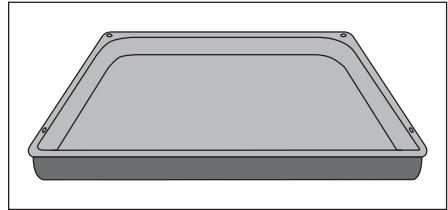

Meat probe

For determining exactly how far joints of meat are cooked.

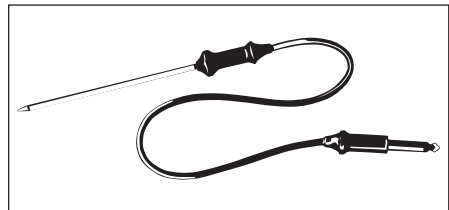

Before Using for the first time

Setting and changing the time

After the appliance has been connected to the electrical supply or when there has been a power cut, the function indicator Time  flashes automatically.

1. To change a time that has already been set, press the + button and the – button at the same time, until the function indicator Time  flashes.

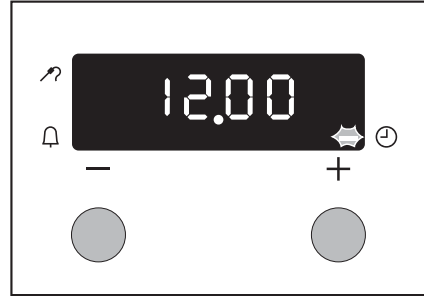

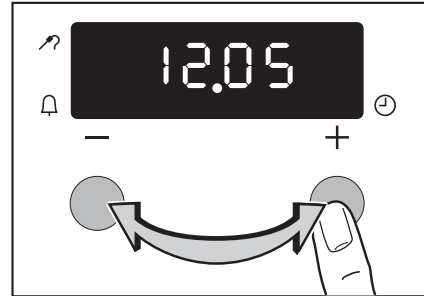

2. Using the + or – button, set the current time.



After approx. 5 seconds, the flashing stops and the clock displays the time of day set.

The appliance is now ready to use.



The Time  can only be changed, if no Countdown  is set.

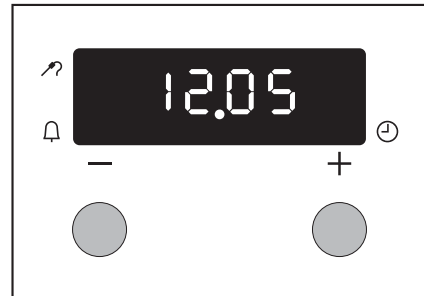

Initial Cleaning

Before using the oven for the first time you should clean it thoroughly.



Caution: Do not use any caustic, abrasive cleaners! The surface could be damaged.



To clean metal fronts use commercially available cleaning agents.

1. Turn the oven function switch to oven lighting .
2. Remove all accessories and the shelf support rails and wash them with warm water and washing up liquid.
3. Then wash out the oven with warm water and washing-up liquid, and dry.
4. Wipe the front of the appliance with a damp cloth.

Using the Oven

Switching the Oven On and Off

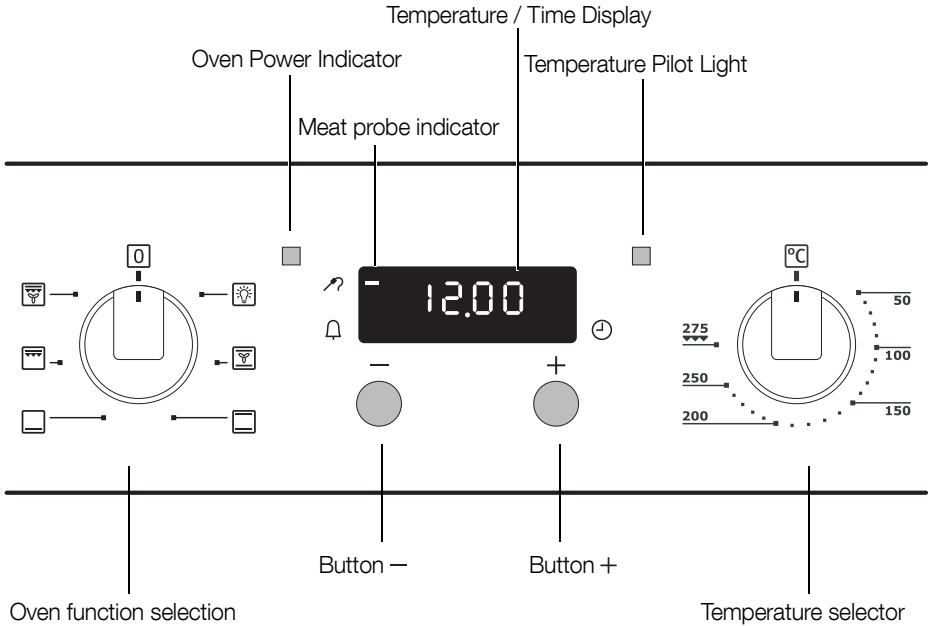

1. Turn the oven functions dial to the desired function.
2. Turn the temperature selector to the desired temperature.

The power indicator is lit as long as the oven is in operation.

The temperature pilot light is lit as long as the oven is heating up.

3. To turn the oven off, turn the oven functions dial and the temperature selector to the Off position.









Cooling fan

The fan switches on automatically in order to keep the appliance's surfaces cool. When the oven is switched off, the fan continues to run to cool the appliance down, then switches itself off automatically.

Oven Functions

The oven has the following functions:

Oven function		Application
	Light	Using this function you can light up the oven interior, e.g. for cleaning.
	Convection	For baking on up to two oven levels . Set the oven temperatures 20-40 °C lower than when using Conventional.
	Conventional	For baking and roasting on one oven level .
	Bottom heat	For baking cakes with crispy or crusty bases .
	Dual grill	For grilling flat food items in large quantities and for toasting .
	Convection grilling	For roasting larger joints of meat or poultry on one level. The function is also suitable for gratinating and browning .

Inserting the Oven Shelf, Baking Tray and Roasting Pan



Shelf runner safety and anti-tip device

As a shelf runner safety device, all insertable components have a small curved indentation at the bottom on the right and left-hand edge.

Always insert insertable components so that this indentation is at the back of the oven interior. This indentation is also important for preventing the insertable components from tipping.

Inserting the baking tray or roasting pan

Push the baking tray or roasting pan between the guide bars of the selected oven level.

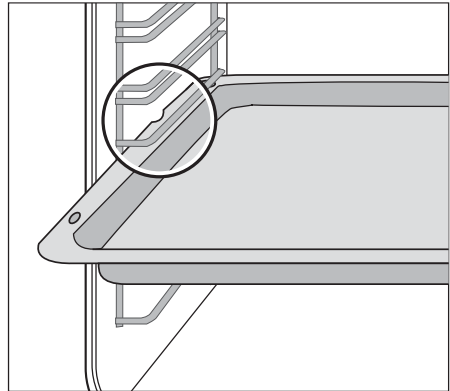

Inserting the oven shelf:

Insert the oven shelf so that the feet point downwards.

Push the oven shelf between the guide bars of the selected oven level.



The high rim around the oven shelf is an additional device to prevent cookware from slipping.

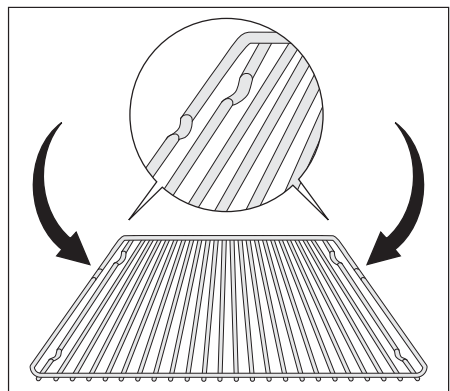

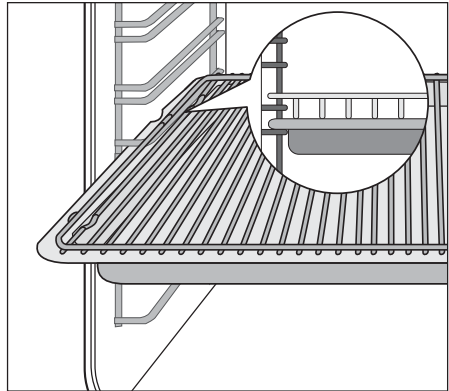

Inserting the oven shelf and roasting pan together

Lay the oven shelf on the roasting pan.
Push the roasting pan **between** the guide bars of the selected oven level.



16 electrolux using the oven

Additional functions

Either Countdown  or Meat probe  can be set.

Countdown

To set a countdown.

Meat probe

To set a core temperature.

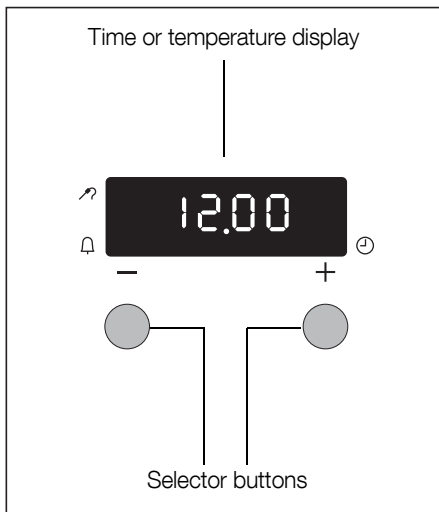



Switching off the time display

You can save energy by switching off the time display.

To switch off the time display

Press the + button and the – button at the same time until the display goes out.

To switch on the time display

Press any button until the time appears in the display again.



The display can only be switched off if no clock function or core temperature  is entered.



General Hints

- After a function has been selected, the display flashes for about 5 seconds. While it flashes, the desired time can be set using the + or – buttons.
- When the desired time has been set, the display flashes for another 5 seconds. The set time begins to run.
- Press any of the buttons to stop the signal.
- The desired oven function and temperature can be selected before or after setting the clock functions.
- When cooking is finished, turn the oven and temperature selectors back to zero.

Countdown



This function has no effect on the operation of the oven.

1. Press any button.
“0.00” flashes in the display.

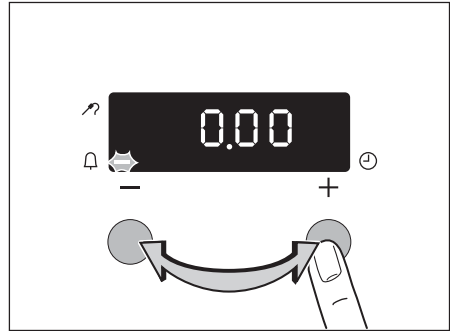

2. Within 5 seconds set the desired countdown using the + or - buttons (max. 2 hours 30 minutes).
After 5 seconds the display shows the time remaining.

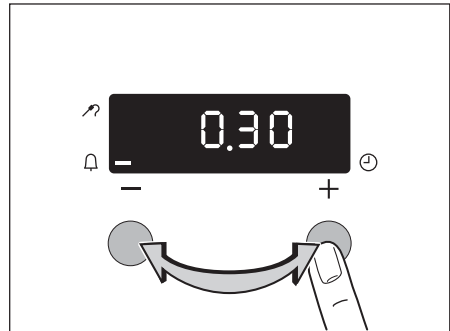

When the time has elapsed, “0.00” is displayed and an audible signal sounds for 2 minutes.

3. The signal can be stopped by pressing any button.

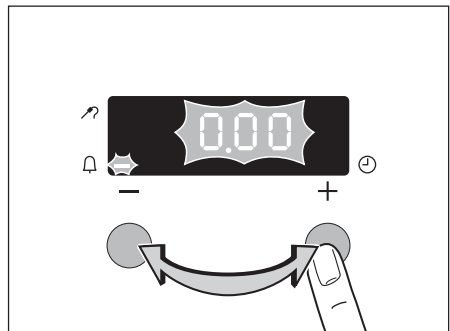

Meat probe



Important: Only the meat probe supplied with the oven may be used. If replacing, please use only original replacement parts.

1. Push the tip of the meat probe right into the meat so that the tip is in the centre of the meat.
2. Insert the meat probe plug into the socket on the side wall of the oven as far as it will go.

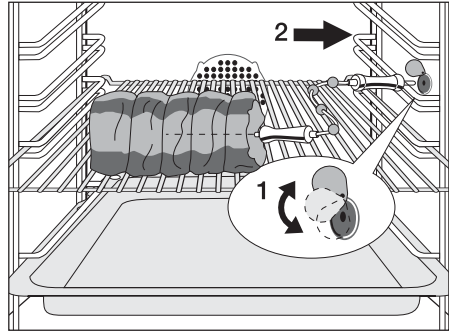

3. Using the + or – button set the desired core temperature.

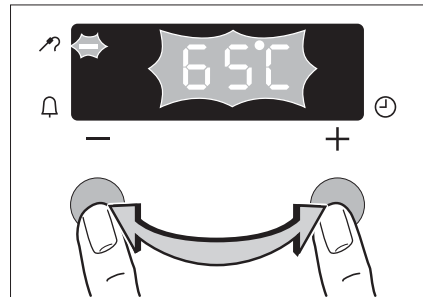

The display changes to the current core temperature.



The core temperature is displayed from 30°C.

4. Set oven function and oven temperature.

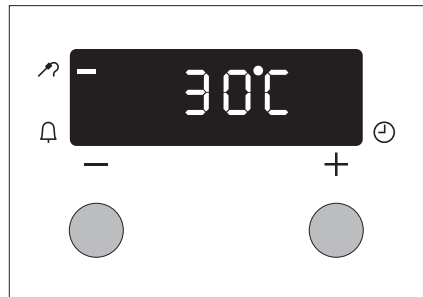

20 electrolux using the oven

As soon as the core temperature set is reached, an audible signal sounds.

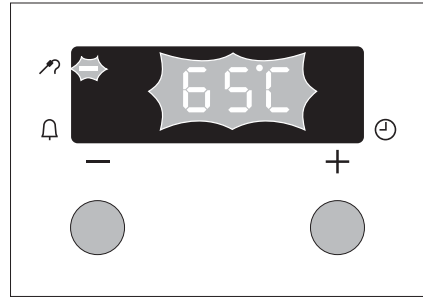

5. Press any key to switch off the signal.
6. Turn oven function selector and temperature selector to the Off position.

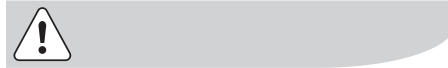

Warning: The meat probe is hot. There is a risk of being burned when removing the plug and the tip of the meat probe.

7. Remove the meat probe's plug from the socket and take the meat out of the oven.

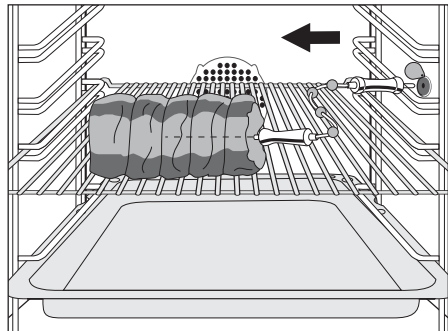

Changing the core temperature

- If necessary, change the temperature using + or –.

Uses, Tables and Tips

Baking

Oven function: Convection or Conventional

Baking tins

- For Conventional , dark metal and non-stick tins are suitable.
- For Convection bright metal tins are also suitable.

Oven levels

- Baking with Conventional is only possible on one level.
- With Convection you can bake dry cakes and biscuits on 2 baking trays at the same time.

1 baking tray:
e.g. oven level 3

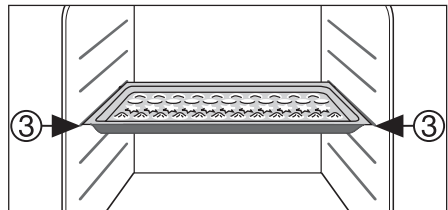

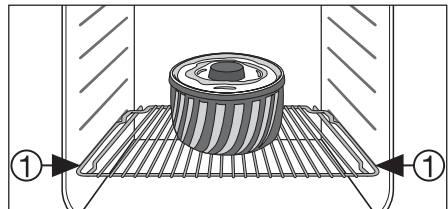

1 cake tin:
e.g. oven level 1

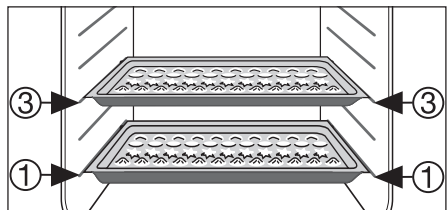

2 baking trays:
e. g. oven levels 1 and 3



General Instructions

- Insert the tray with the bevel at the front.
- With Conventional  or Convection  you can also bake with two tins next to one another on the oven shelf at the same time. This does not significantly increase baking time.



When frozen foods are used the trays inserted may distort during cooking. This is due to the large difference in temperature between the freezing temperature and the temperature in the oven. Once the trays have cooled the distortion will disappear again.

How to use the Baking Tables

The tables give the required temperature settings, baking times and oven shelf levels for a selection of typical dishes.





















- Temperatures and baking times are for guidance only, as these will depend on the consistency of pastry or mixture, the number and the type of cake tin.
- We recommend using the lower temperature the first time and then if necessary, for example, if a deeper browning is required, or baking time is too long, selecting a higher temperature.
- If you cannot find the settings for a particular recipe, look for the one that is most similar.
- If baking cakes on baking trays or in tins on more than one level, baking time can be extended by 10-15 minutes.

- Moist recipes (for example, pizzas, fruit flans, etc.) are baked on one level.
- Cakes and pastries at different heights may brown at an uneven rate at first. If this occurs, **please do not change the temperature setting.** Different rates of browning even out as baking progresses.
- Your new oven may bake or roast differently to your previous appliance. So adapt your normal settings (temperature, cooking times) and oven shelf levels to the recommendations in the following tables.























With longer baking times, you can switch the oven off about 10 minutes before the end of the baking time, in order to utilise the residual heat.
Unless otherwise stated, the values given in the tables assume that cooking is started with the oven cold.

Baking table

Type of baking	Ovenfunction	Shelf position	Temperature °C	Time Hours mins.	
Baking in tins					
Ring cake or brioche		Convection	1	150-160	0:50-1:10
Madeira cake/Fruitcakes		Convection	1	140-160	1:10-1:30
Sponge cake		Convection	1	140	0:25-0:40
Sponge cake		Conventional	1	160	0:25-0:40
Flan base - short pastry		Conventional	3	180-200	0:10-0:25
Flan base - sponge mixture		Convection	3	150-170	0:20-0:25
Apple pie		Conventional	1	170-190	0:50-1:00
Apple pie (2tins Ø20cm, diagonally off set)		Convection	1	160	1:10-1:30
Apple pie (2tins Ø20cm, diagonally off set)		Conventional	1	180	1:10-1:30
Savoury flan (e. g. quiche lorraine)		Conventional	1	180-200	0:30-1:10
Cheesecake		Conventional	1	170-190	1:00-1:30
Cakes/pastries/breads on baking trays					
Plaited bread/bread crown		Conventional	3	170-190	0:30-0:40
Christmas stollen		Conventional	3	160-180 ¹⁾	0:40-1:00
Bread (rye bread) -first of all -then		Conventional	1	250 ¹⁾ 160-180	0:20 0:30-1:00
Cream puffs/Eclairs		Convection	3	160-170 ¹⁾	0:15-0:30
Swiss roll		Conventional	3	180-200 ¹⁾	0:10-0:20
Cake with crumble topping(dry)		Convection	3	150-160	0:20-0:40
Buttered almond cake/sugar cakes		Conventional	3	190-210 ¹⁾	0:15-0:30
Fruit flans (made with yeast dough/sponge mixture) ²⁾		Convection	3	150	0:35-0:50
Fruit flans (made with yeast dough/sponge mixture)		Conventional	3	170	0:35-0:50
Fruit flans made with short pastry		Conventional	3	170-190	0:40-1:20

24 electrolux uses, tables and tips

Type of baking	Ovenfunction	Shelf position	Temperature °C	Time Hours mins.	
Yeast cakes with delicate toppings (e. g. quark, cream, vanilla cream)		Conventional	3	160-180	0:40-1:20
Pizza (with a lot of topping) ²		Conventional	1	190-210 ¹⁾	0:30-1:00
Pizza (thin crust)		Conventional	1	230-250 ¹⁾	0:10-0:25
Unleavened bread		Conventional	1	250-270	0:08-0:15
Tarts (CH)		Conventional	1	200-220	0:35-0:50
Biscuits					
Short pastry biscuits		Convection	3	150-160	0:06-0:20
Short pastry biscuits		Convection	1 / 3	150-160	0:06-0:20
Viennese whirls		Convection	3	140	0:20-0:30
Viennese whirls		Convection	1 / 3	140	0:25-0:40
Viennese whirls		Conventional	3	160 ¹⁾	0:20-0:30
Biscuits made with sponge mixture		Convection	3	150-160	0:15-0:20
Biscuits made with sponge mixture		Convection	1 / 3	150-160	0:15-0:20
Pastries made with egg white, meringues		Convection	3	80-100	2:00-2:30
Macaroons		Convection	3	100-120	0:30-0:60
Biscuits made with yeast dough		Convection	3	150-160	0:20-0:40
Puff pastries		Convection	3	170-180 ¹⁾	0:20-0:30
Rolls		Convection	3	160 ¹⁾	0:20-0:35
Rolls		Conventional	3	180 ¹⁾	0:20-0:35
Small cakes (20per tray)		Convection	3	140 ¹⁾	0:20-0:30
Small cakes (20per tray)		Convection	1 / 4	140 ¹⁾	0:25-0:40
Small cakes (20per tray)		Conventional	3	170 ¹⁾	0:20-0:30

1) Pre-heat the oven

2) Use the drip tray or roasting tray

Tips on baking





Baking results	Possible cause	Remedy
The cake is not browned enough at the bottom	Wrong oven level	Place cake lower in the oven
The cake sinks (becomes soggy, lumpy, streaky)	Oven temperature too high	Use a slightly lower setting
	Baking time too short	Set a longer baking time Baking times cannot be reduced by setting higher temperatures
	Too much liquid in the mixture	Use less liquid Pay attention to mixing times, especially if using mixing machines
Cake is too dry	Oven temperature too low	Set oven temperature higher
	Baking time too long	Set a shorter baking time
Cake browns unevenly	Oven temperature too high and baking time too short	Set a lower oven temperature and a longer baking time
	Mixture is unevenly distributed	Spread the mixture evenly on the baking tray
Cake is not done within the baking time given	Temperature too low	Use a slightly higher oven setting

Bakes and gratins table

Dish	Oven function	Shelf position	Temperature °C	Time Hours mins.
Pasta bake	 Conventional	1	180-200	0:45-1:00
Lasagne	 Conventional	1	180-200	0:25-0:40
Vegetables au gratin ¹⁾	 Convection grilling	1	160-170	0:15-0:30
Baguettes topped with melted cheese ¹⁾	 Convection grilling	1	160-170	0:15-0:30
Sweet bakes	 Conventional	1	180-200	0:40-0:60
Fish bakes	 Conventional	1	180-200	0:30-1:00
Stuffed vegetables	 Convection grilling	1	160-170	0:30-1:00

1) Pre-heat the oven

Frozen ready meals table

Food to be cooked	Oven function	Shelf position	Temperature °C	Time
Frozen pizza	 Conventional	3	as per manufacturer's instructions	as per manufacturer's instructions
Chips ¹⁾ (300-600 g)	 Convection grilling	3	200-220	as per manufacturer's instructions
Baguettes	 Conventional	3	as per manufacturer's instructions	as per manufacturer's instructions
Fruit flans	 Conventional	3	as per manufacturer's instructions	as per manufacturer's instructions

1) Comments: Turn chips 2 or 3 times during cooking

Roasting

Oven function: Conventional  **or Convection grilling** 

Roasting dishes













- Any heat-resistant ovenware is suitable to use for roasting (please read the manufacturer's instructions).
- Large roasting joints can be roasted **directly in the roasting tray or on the oven shelf with the roasting tray placed below it.**
- For all lean meats, we recommend **roasting these in a roasting tin with a lid.** This will keep the meat more succulent.
- All types of meat, that can be browned or have crackling, can be roasted in the **roasting tin without the lid.**



Tips on using the roasting chart
The information given in the following table is for guidance only.

- We recommend cooking meat and fish **weighing 1 kg and above in the oven.**
- To prevent escaping meat juices or fat from burning on to the pan, we recommend placing some liquid in the roasting pan.
- If required, turn the roast (after 1/2 - 2/3 of the cooking time).
- Baste large roasts and poultry with their juices several times during roasting. This will give better roasting results.
- You can switch the oven off about 10 minutes before the end of the roasting time, in order to utilise the residual heat.

Roasting table

Type of meat	Quantity	Ovenfunction	Shelf position	Temperature °C	Time Hours mins.	
Beef						
Pot roast	1-1.5 kg		Conventional	1	200-250	2:00-2:30
Roast beef or fillet						per cm. of thickness
- rare	per cm. of thickness		Convection grilling	1	190-200 ¹⁾	0:05-0:06
- medium	per cm. of thickness		Convection grilling	1	180-190	0:06-0:08
- well done	per cm. of thickness		Convection grilling	1	170-180	0:08-0:10
Pork						
Shoulder, neck, ham joint	1-1.5 kg		Convection grilling	1	160-180	1:30-2:00
Chop, spare rib	1-1.5 kg		Convection grilling	1	170-180	1:00-1:30
Meat loaf	750 g-1 kg		Convection grilling	1	160-170	0:45-1:00
Porkknuckle (pre-cooked)	750 g-1 kg		Convection grilling	1	150-170	1:30-2:00
Veal						
Roast veal	1 kg		Convection grilling	1	160-180	1:30-2:00
Knuckle of veal	1.5-2 kg		Convection grilling	1	160-180	2:00-2:30
Lamb						
Leg of lamb, roast lamb	1-1.5 kg		Convection grilling	1	150-170	1:15-2:00
Saddle of lamb	1-1.5 kg		Convection grilling	1	160-180	1:00-1:30

Type of meat	Quantity	Ovenfunction	Shelf position	Temperature °C	Time Hours mins.
Game					
Saddle of hare, leg of hare	up to 1 kg	 Conventional	3	220-250 ¹⁾	0:25-0:40
Saddle of venison	1.5-2 kg	 Conventional	1	210-220	1:15-1:45
Haunch of venison	1.5-2 kg	 Conventional	1	200-210	1:30-2:15
Poultry					
Poultry portions	200-250g each	 Convection grilling	1	200-220	0:35-0:50
Half chicken	400-500g each	 Convection grilling	1	190-210	0:35-0:50
Chicken, poulard	1-1.5 kg	 Convection grilling	1	190-210	0:45-1:15
Duck	1.5-2 kg	 Convection grilling	1	180-200	1:15-1:45
Goose	3.5-5 kg	 Convection grilling	1	160-180	2:30-3:30
Turkey	2.5-3.5 kg	 Convection grilling	1	160-180	1:45-2:30
Turkey	4-6 kg	 Convection grilling	1	140-160	2:30-4:00
Fish (steamed)					
Whole fish	1-1.5 kg	 Conventional	1	210-220	0:45-1:15

1) Pre-heat the oven

Wide grilling

Oven function: Dual grill  with maximum temperature setting



Important: Always grill with the oven door closed.



The empty oven should always be pre-heated with the grill functions for 5 minutes.

- For grilling, place the **shelf** in the **recommended shelf position**.
- Always insert the **tray for collecting the fat** into the **first shelf position** from the bottom.
- The grilling times are guidelines.
- Grilling is particularly suitable for flat pieces of meat or fish.

Grilling table

Food to be grilled	Oven level	Grilling time	
		1st side	2nd side
Burgers	4	8-10 mins.	6-8 mins.
Pork fillet	4	10-12 mins.	6-10 mins.
Sausages	4	8-10 mins.	6-8 mins.
Fillet steaks, veal steaks	4	6-7 mins.	5-6 mins.
Fillet of beef, roast beef (approx. 1 kg)	3	10-12 mins.	10-12 mins.
Toast ¹⁾	3	4-6 mins.	3-5 mins.
Toast with topping	3	6-8 mins.	---

1) Do not pre-heat

Making preserves

Oven function: Bottom heat

- For preserving, use only commercially available preserve jars of the same size.
- **Jars with twist-off or bayonet type lids and metal tins are not suitable.**
- When making preserves, the **first shelf position from the bottom** is the one most used.
- Use the shelf for making preserves. There is enough room on this for up to six 1-litre preserving jars.
- The jars should all be filled to the same level and clamped shut.
- Place the jars on the baking tray in such a way that they are not touching each other.
- Pour approx. 1/2 litre of water into the baking tray so that sufficient moisture is produced in the oven.
- As soon as the liquid starts to pearl in the first jars (after about 35-60 minutes with 1 litre jars), switch the oven off or reduce the temperature to 100°C (see table).

Preserves table

The times and temperatures for making preserves are for guidance only.

Preserve	Temperature in °C	Cooking time until simmering in mins.	Continue to cook at 100°C in mins.
Soft fruit			
Strawberries, blueberries, raspberries, ripe gooseberries	160-170	35-45	---
Unripe gooseberries	160-170	35-45	10-15
Stone fruit			
Pears, quinces, plums	160-170	35-45	10-15
Vegetables			
Carrots ¹⁾	160-170	50-60	5-10
Mushrooms ¹⁾	160-170	40-60	10-15
Cucumbers	160-170	50-60	---
Mixed pickles	160-170	50-60	15
Kohlrabi, peas, asparagus	160-170	50-60	15-20
Beans	160-170	50-60	---

1) Leave standing in oven when switched off

Drying

Oven function: Convection

- Use oven shelves covered with greaseproof paper or baking parchment.
- You get a better result if you switch the oven off halfway through the drying time, open the door and leave the oven to cool down overnight.
- After this finish drying the food to be dried.

Food to be dried	Temperature in °C	Oven level		Time in hours (Guideline)
		1 level	2 levels	
Vegetables				
Beans	60-70	3	1 / 4	6-8
Peppers (strips)	60-70	3	1 / 4	5-6
Vegetables for soup	60-70	3	1 / 4	5-6
Mushrooms	50-60	3	1 / 4	6-8
Herbs	40-50	3	1 / 4	2-3
Fruit				
Plums	60-70	3	1 / 4	8-10
Apricots	60-70	3	1 / 4	8-10
Apple slices	60-70	3	1 / 4	6-8
Pears	60-70	3	1 / 4	6-9

Cleaning and Care



Warning: First switch off the appliance and let it cool down before carrying out any cleaning.

Warning: For safety reasons, do **not** clean the appliance with steam blasters or high-pressure cleaners.

Attention: Do not use any corrosive cleaning fluids, sharp objects or stain removers.

Do not clean the glass oven door with abrasive fluids or metal scrapers, which could scratch the surface. The glass could crack and shatter.

Outside of the appliance

- Wipe the front of the appliance with a soft cloth and a solution of hot water and washing up liquid.
- For metal fronts, use normal commercially available cleaning agents.
- Please do not use scouring agents and abrasive sponges.

Oven interior

Clean the appliance after each use. In this way, dirt is easier to clean off and is not allowed to burn on.

1. For cleaning, turn the oven light on.
2. After every use, wipe the oven with a solution of washing-up liquid and allow to dry.



Clean stubborn dirt with a special oven cleaner.



Important: If using an oven spray, please follow the manufacturer's instructions exactly.

Accessories

Wash all slide-in units (shelf unit, baking tray, shelf support rails etc.) after each use and dry well. Soak briefly to make them easier to clean.

Shelf Support Rails

The shelf support rails on the left and right hand sides of the oven can be removed for cleaning the side walls.

Removing the shelf support rails

First pull the front of the rail away from the oven wall (1) and then unhitch at the back (2).

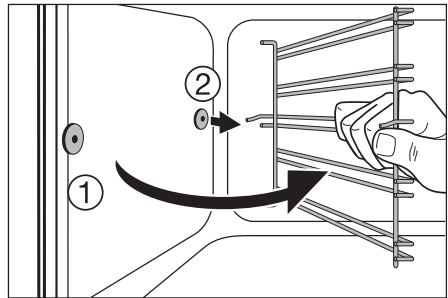
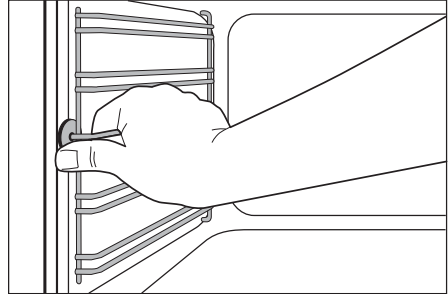

Fitting the shelf support rails



Important! The rounded ends of the guide rails must be pointing forwards!

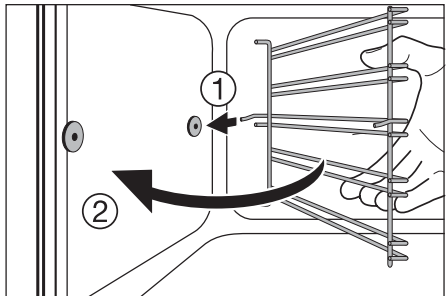
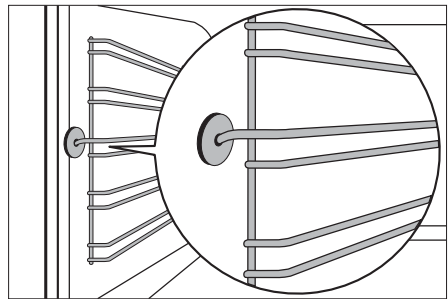

To re-insert, first hook the rail into place at the back (1) and then insert the front and press into place (2).

Oven Lighting



Warning: Risk of electric shock! Prior to changing the oven light bulb:

- Switch off the oven!
- Disconnect from the electricity supply.



Place a cloth on the oven floor to protect the oven light and glass cover.

Changing the oven light bulb/cleaning the glass cover

1. Remove the glass cover by turning it anti-clockwise and then clean it.
2. If necessary: replace with **25 watt, 230 V, 300 °C heat-resistant oven lighting.**
3. Refit the glass cover.

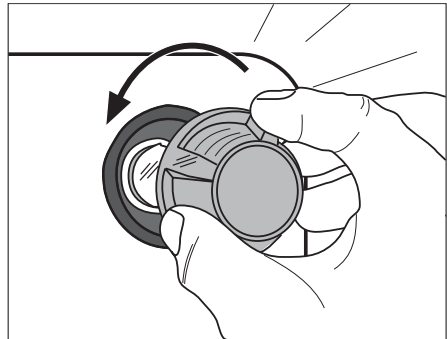

Oven Ceiling

The upper heating element can be folded down to make it easier to clean the oven ceiling.

Folding down the heating element



Warning: Only fold down the heating element when the oven is switched off and there is no risk of being burnt!

1. Remove the side shelf support rails.
2. Grip the heating element at the front and pull it forwards and out over the support lug on the inner wall of the oven.
3. The heating element will now fold down.



Caution: Do not use force to press the heating element down! The heating element might break.

Cleaning the oven ceiling

Repositioning the heating element

1. Move the heating element back up towards the oven ceiling.
2. Pull the heating element forwards against the spring pressure and guide it over the oven support lug.
3. Settle it onto the support.
4. Insert shelf support rail.



Important: The heating element must be positioned correctly and securely on both sides above the support lug on the inner wall of the oven.

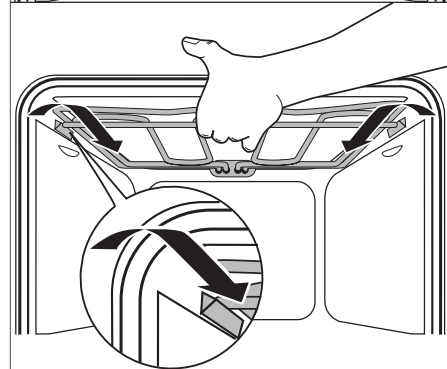
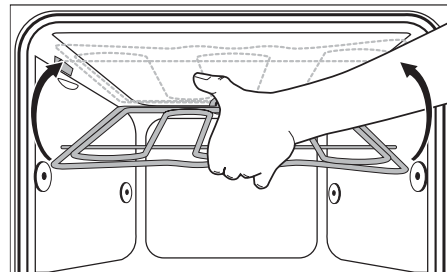
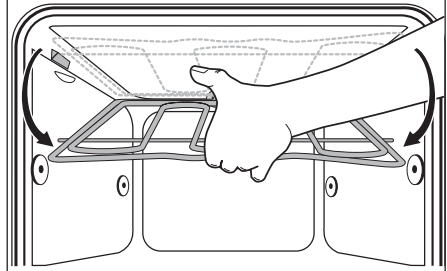
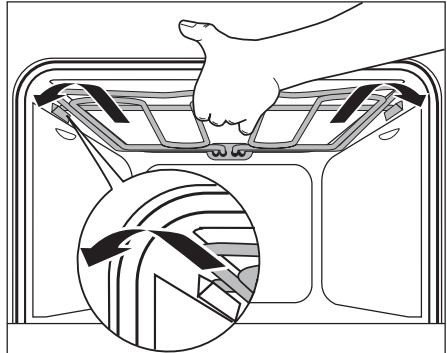

Oven door

For easier cleaning of the oven interior the oven door of your appliance can be taken off its hinges.

Removing the oven door from its hinges

1. Open the oven door as far as it will go.

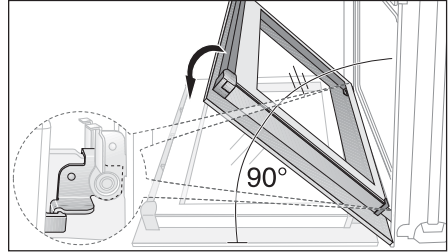

2. Undo the **clamping levers (A)** on both door hinges **fully**.

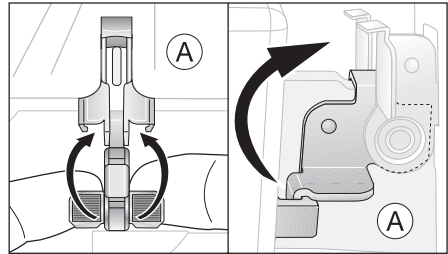

3. Close the oven door as far as the first position (approx. 45°).

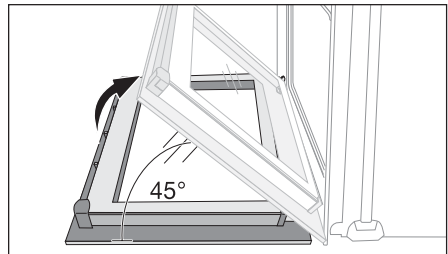

4. Take hold of the oven door with a hand on each side and pull it away from the oven at an upwards angle (**Take care:** It is heavy).



Lay the oven door with the outer side facing downwards on something soft and level, for example, a blanket in order to prevent scratches.

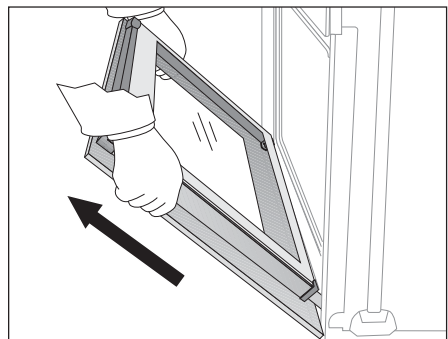

Hanging the oven door back on its hinges

1. From the handle side take hold of the oven door with a hand on each side and hold at an angle of approx. 45°. Position the recesses on the bottom of the oven door on the hinges on the oven.
Let the door slide down as far as it will go.

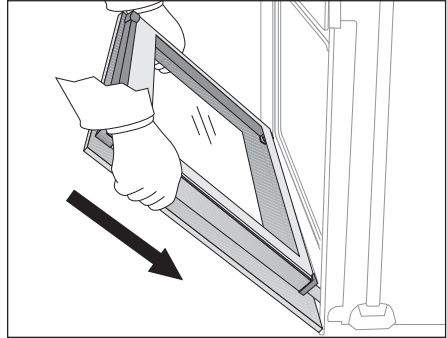

2. Open the oven door as far as it will go.

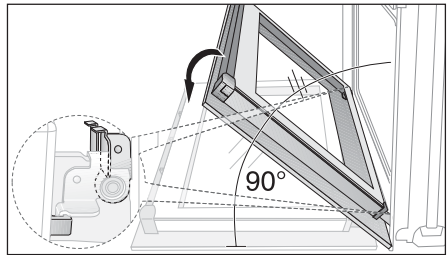

3. Fold up the clamping levers (A) on both door hinges back into their original positions.

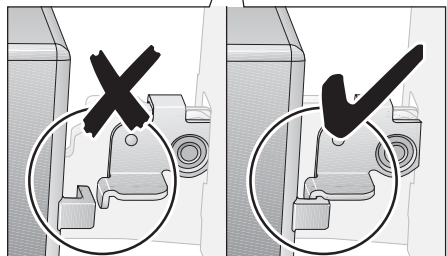
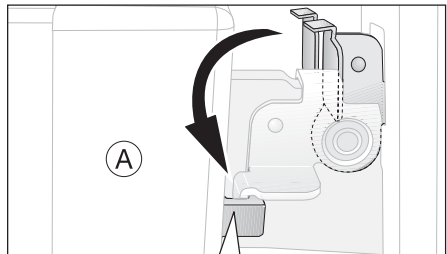

4. Close the oven door.

Oven door glass

The oven door is fitted with two panels of glass mounted one behind the other. The inner panel can be removed for cleaning.



Important Rough handling, especially around the edges of the front panel, can cause the glass to break.

Removing the door glass

1. Open the oven door as far as it will go.

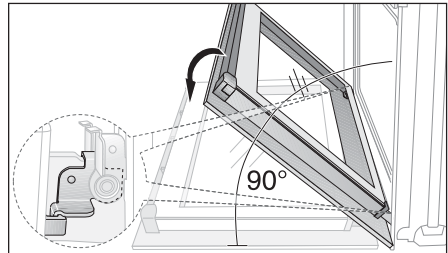

2. Undo the **clamping levers (A)** on both door hinges **fully**.

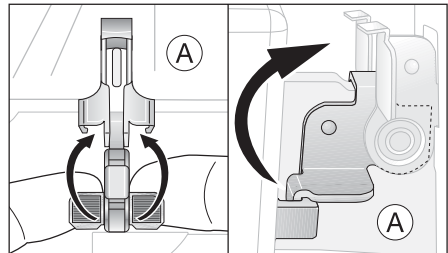

3. Close the oven door as far as the first position (approx. 45°).

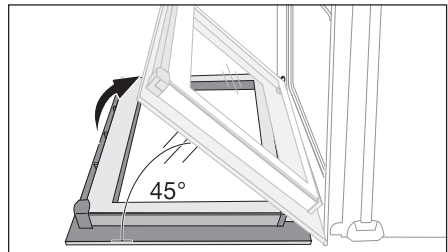

40 electrolux **cleaning and care**

4. Take hold of the door trim (B) on the upper edge of the door at both sides and press inwards to release the clip seal. Then remove the door trim by pulling upwards.

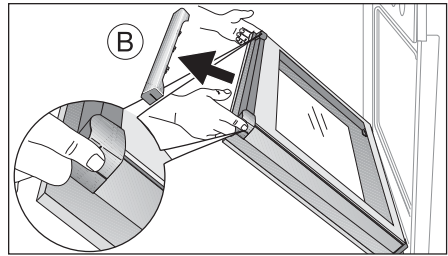

5. Take hold of the door glass on its upper edge and take it out of the guide by pulling it upwards.

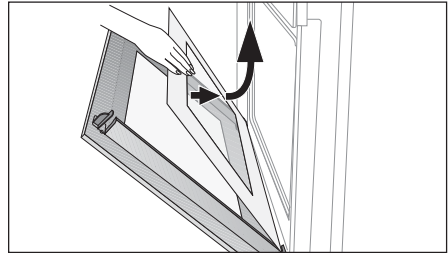

Cleaning the door glass

Clean the door glass thoroughly with a solution of water and washing up liquid. Then dry it carefully.

Putting the door glass back

1. From above insert the door glass at an angle into the door profile at the bottom edge of the door and lower it.
2. Take hold of the door trim (B) at each side, position it on the inside edge of the door and plug the door trim (B) into the upper edge of the door.

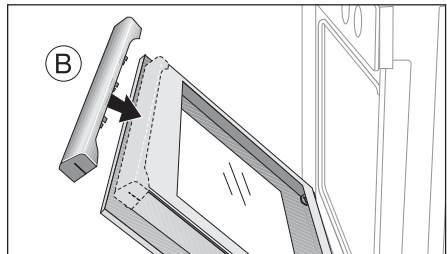
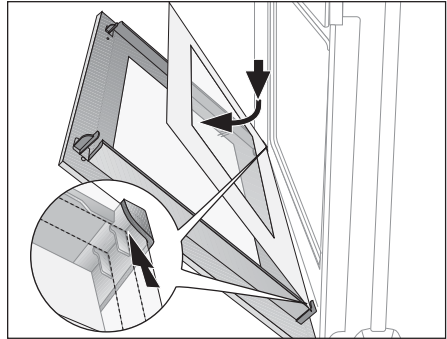

On the open side of the door trim (B) there is a guide bar (C). This must be pushed between the outer door panel and the guide corner (D). The clip seal (E) must be snapped in.

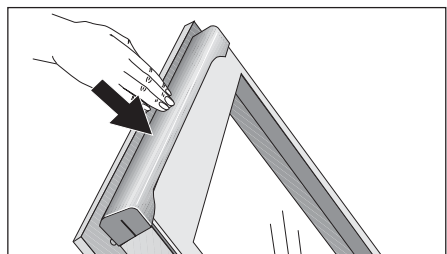
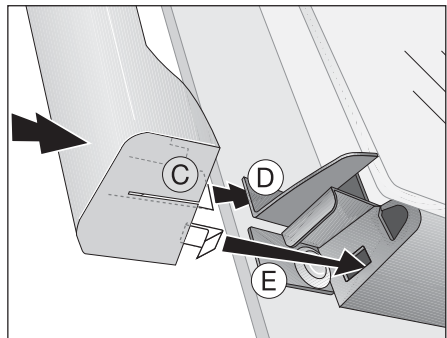

42 electrolux **cleaning and care**

3. Open the oven door as far as it will go.

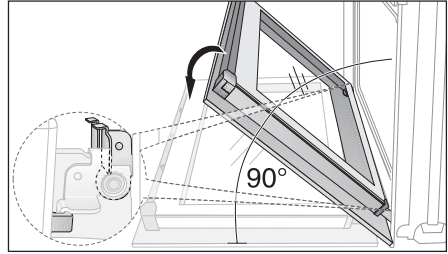

4. Fold up the clamping levers (A) on both door hinges back into their original positions.

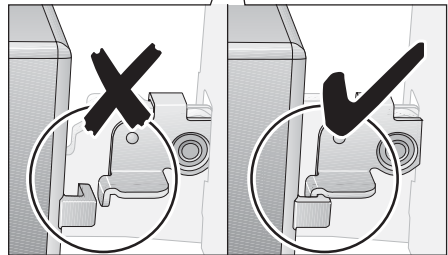
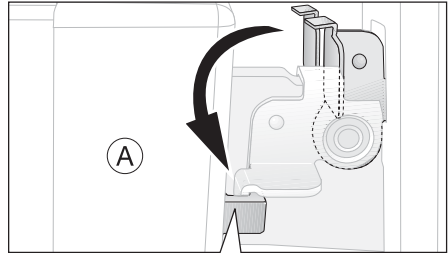

5. Close the oven door.

What to do if ...

Problem	Possible cause	Remedy
The oven does not heat up	The oven is not switched on	Switch the oven on
	The required settings have not been set	Check the settings
	The house wiring fuse (in the fuse box) has tripped	Check the fuse If the fuses trip several times, please call a qualified electrician
The oven lighting is not operating	The oven light bulb is faulty	Replace the oven bulb
F11 appears in the clock display	The meat probe has short circuited or the plug of the meat probe is not firmly in position in the socket	Insert the plug of the meat probe as far as it will go into the socket on the side wall of the oven

If you are unable to remedy the problem by following the above suggestions, please contact your local Service Force Centre.



Warning! Repairs to the appliance are only to be carried out by qualified service engineers. Considerable danger to the user may result from improper repairs.



If the appliance has been operated incorrectly, the engineer's visit will be chargeable, even during the warranty period.



Advice on cookers with metal fronts:

Because of the cold surface at the front of the cooker, opening the oven door during (or just after) baking or roasting may cause the glass to steam up.

Installation Instructions



Attention: The new appliance may only be installed and connected by a registered expert.

Please comply with this. If you do not, any damage resulting is not covered by the warranty.



Safety information for the installer

- The electrical installation is to be set up so that the appliance can be isolated from the mains with a minimum 3mm all-pole contact separation. Suitable separation devices include e.g. cut-outs, fuses (screw fuses are to be taken out of the holder), RCD's and contactors.
- Anti-shock protection must be provided by the installation.
- The built-in unit must meet the stability requirements of DIN 68930.
- Built-in ovens and built-in cooking surfaces are fitted with special connection systems. For safety reasons, they must only be combined with appliances from the same manufacturer.

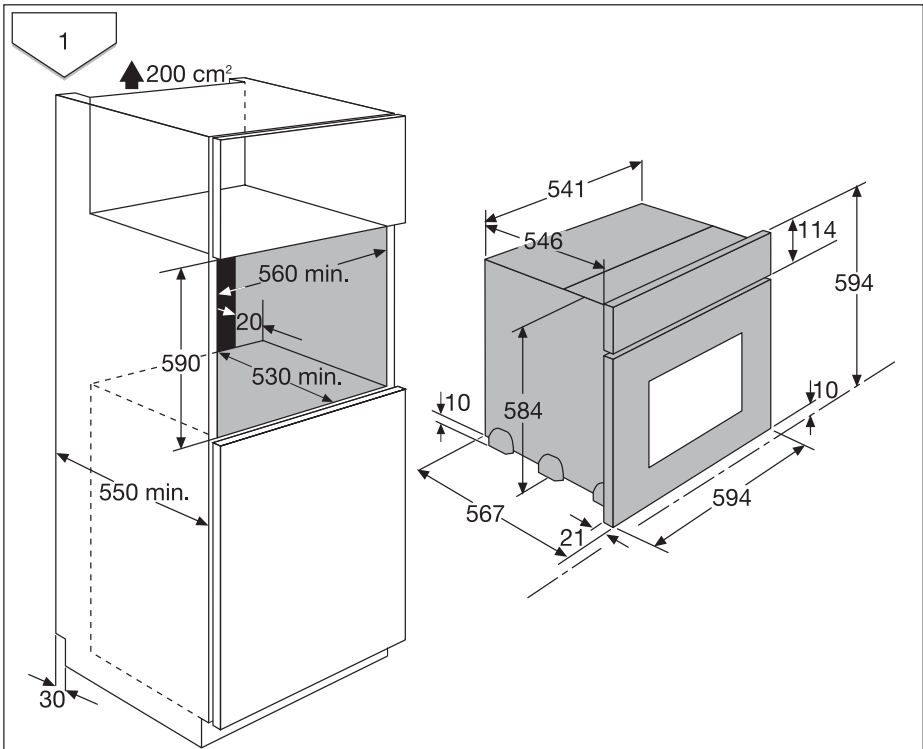

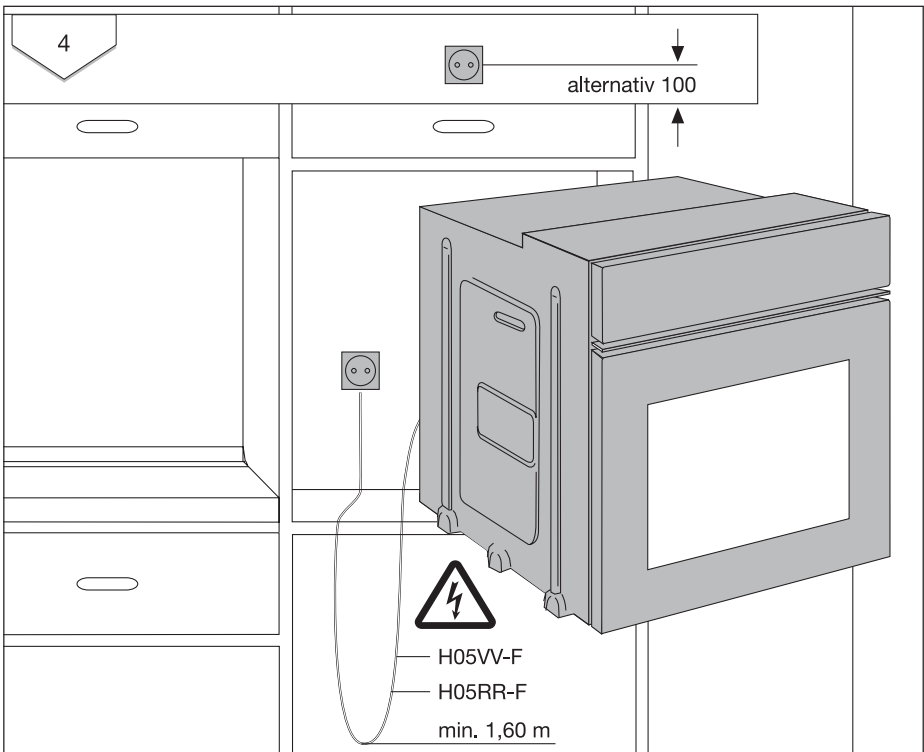
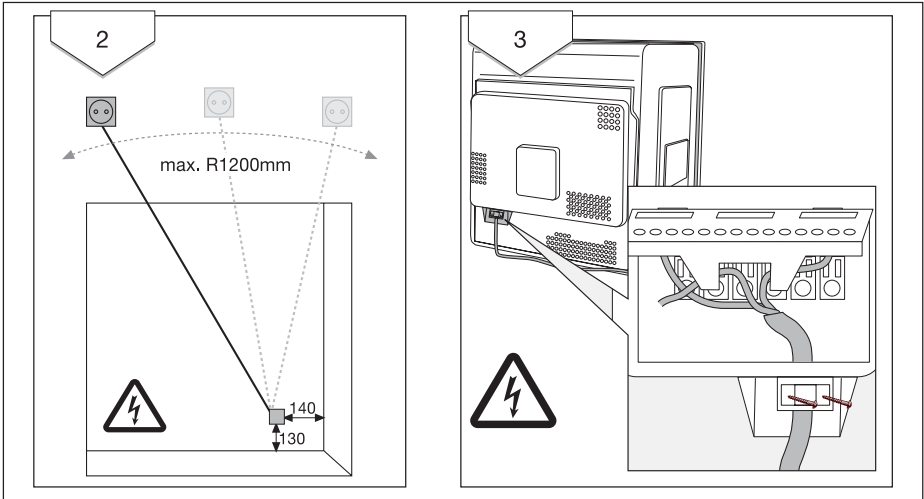

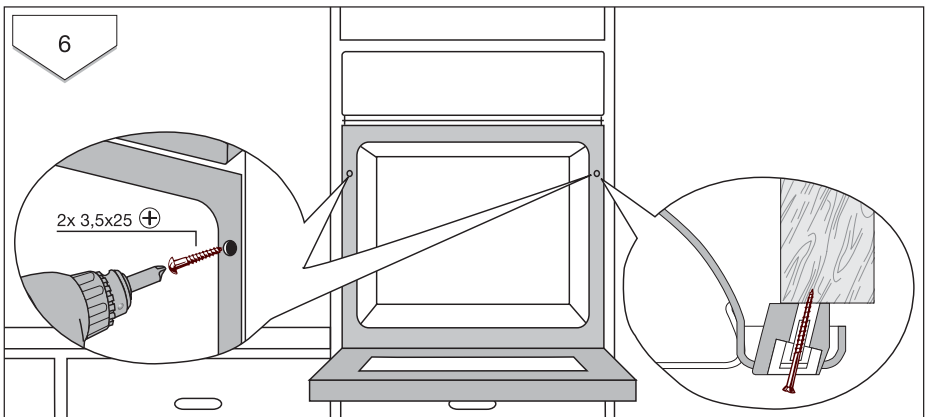
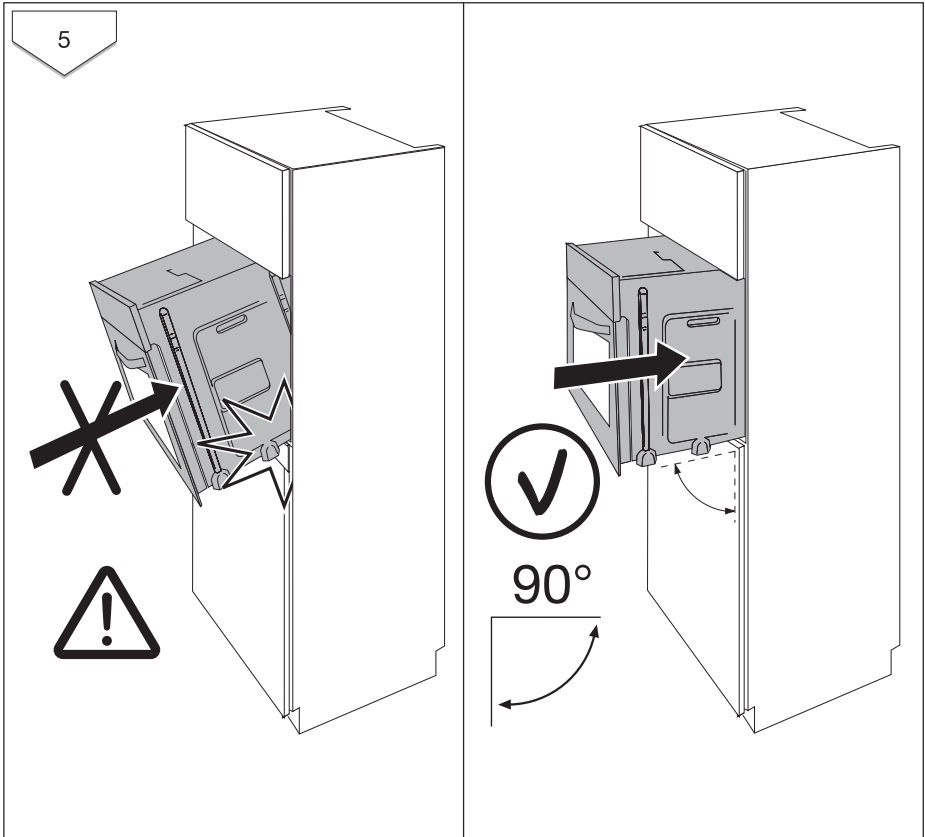

Disposal



Packaging material

The packaging materials are environmentally friendly and can be recycled. The plastic components are identified by markings, e.g. >PE<, >PS<, etc. Please dispose of the packaging materials in the appropriate container at the community waste disposal facilities.



Old appliance

The symbol  on the product or on its packaging indicates that this product may not be treated as household waste. Instead it shall be handed over to the applicable collection point for the recycling of electrical and electronic equipment. By ensuring this product is disposed of correctly, you will help prevent potential negative consequences for the environment and human health, which could otherwise be caused by inappropriate waste handling of this product. For more detailed information about recycling of this product, please contact your local city office, your household waste disposal service or the shop where you purchased the product.



Warning: So that the old appliance can no longer cause any danger, make it unusable before disposing of it.

To do this, disconnect the appliance from the mains supply and remove the mains cable from the appliance.

Guarantee/Customer Service



European Guarantee

This appliance is guaranteed by Electrolux in each of the countries listed at the back of this user manual, for the period specified in the appliance guarantee or otherwise by law. If you move from one of these countries to another of the countries listed below the appliance guarantee will move with you subject to the following qualifications:

- The appliance guarantee starts from the date you first purchased the appliance which will be evidenced by production of a valid purchase document issued by the seller of the appliance.
- The appliance guarantee is for the same period and to the same extent for labour and parts as exists in your new country of residence for this particular model or range of appliances.
- The appliance guarantee is personal to the original purchaser of the appliance and cannot be transferred to another user.
- The appliance is installed and used in accordance with instructions issued by Electrolux and is only used within the home, i.e. is not used for commercial purposes.
- The appliance is installed in accordance with all relevant regulations in force within your new country of residence.

The provisions of this European Guarantee do not affect any of the rights granted to you by law.

www.electrolux.com

		
Albania	+35 5 4 261 450	Rr. Pjeter Bogdani Nr. 7 Tirane
Belgique/België/ Belgien	+32 2 363 04 44	Bergensesteenweg 719, 1502 Lembeek
Česká republika	+420 2 61 12 61 12	Budějovická 3, Praha 4, 140 21
Danmark	+45 70 11 74 00	Sjællandsgade 2, 7000 Fredericia
Deutschland	+49 180 32 26 622	Muggenhofer Str. 135, 90429 Nürnberg
Eesti	+37 2 66 50 030	Mustamäe tee 24, 10621 Tallinn
España	+34 902 11 63 88	Carretera M-300, Km. 29,900 Alcalá de Henares Madrid
France	www.electrolux.fr	

		
Great Britain	+44 8705 929 929	Addington Way, Luton, Bedfordshire LU4 9QQ
Hellas	+30 23 10 56 19 70	4 Limnou Str., 54627 Thessaloniki
Hrvatska	+385 1 63 23 338	Slavonska avenija 3, 10000 Zagreb
Ireland	+353 1 40 90 753	Long Mile Road Dublin 12
Italia	+39 (0) 434 558500	C.so Lino Zanussi, 26 - 33080 Porcia (PN)
Latvija	+37 17 84 59 34	Kr. Barona iela 130/2, LV-1012, Riga
Lithuania	+3702780607	Žirmūnų 67, LT-09001 Vilnius
Luxembourg	+352 42 431 301	Rue de Bitbourg, 7, L-1273 Hamm
Magyarország	+36 1 252 1773	H-1142 Budapest XIV, Erzsébet királyné útja 87
Nederland	+31 17 24 68 300	Vennootsweg 1, 2404 CG - Alphen aan den Rijn
Norge	+47 81 5 30 222	Risløkkvn. 2 , 0508 Oslo
Österreich	+43 18 66 400	Herziggasse 9, 1230 Wien
Polska	+48 22 43 47 300	ul. Kolejowa 5/7, Warszawa
Portugal	+35 12 14 40 39 39	Quinta da Fonte - Edifício Gonçalves Zarco - Q 35 2774 - 518 Paço de Arcos
Romania	+40 21 451 20 30	Str. Garii Progresului 2, S4, 040671 RO
Schweiz/Suisse/Svizzera	+41 62 88 99 111	Industriestrasse 10, CH-5506 Mägenwil
Slovenija	+38 61 24 25 731	Electrolux Ljubljana d.o.o. Gerbičeva 98, 1000 Ljubljana
Slovensko	+421 2 43 33 43 22	Electrolux Slovakia s.r.o., Electrolux Domáce spotrebiče SK, Seberínho 1, 821 03 Bratislava
Suomi	www.electrolux.fi	
Sverige	+46 (0)771 76 76 76	Electrolux Service, S:t Göransgatan 143, S-105 45 Stockholm
Türkiye	+90 21 22 93 10 25	Tarlabası caddesi no : 35 Taksim Istanbul
Россия	+7 495 937 7837	129090 Москва, Олимпийский проспект, 16, БЦ „Олимпик“
Україна	+380 44 586 20 60	04074 Київ, вул.Автозаводська, 2а, БЦ „Алкон“

Service

In the event of technical faults, please first check whether you can remedy the problem yourself with the help of the operating instructions (section “What to do if...”).

If you were not able to remedy the problem yourself, please contact the Customer Care Department or one of our service partners.

In order to be able to assist you quickly, we require the following information:

- Model description
- Product number (PNC)
- Serial number (S No.)
(for numbers see rating plate)
- Type of fault
- Any error messages displayed by the appliance

So that you have the necessary reference numbers from your appliance at hand, we recommend that you write them in here:

Model description:

PNC:

S No:

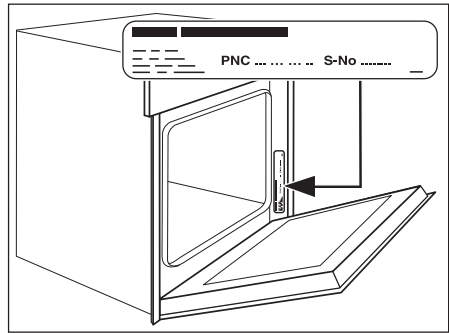

www.electrolux.com