



September 1986
Revised February 2000

DM74174 Hex/Quad D-Type Flip-Flop with Clear

General Description

These positive-edge triggered flip-flops utilize TTL circuitry to implement D-type flip-flop logic. All have a direct clear input.

Information at the D inputs meeting the setup and hold time requirements is transferred to the Q outputs on the positive-going edge of the clock pulse. Clock triggering occurs at a particular voltage level and is not directly related to the transition time of the positive-going pulse. When the clock input is at either the HIGH or LOW level, the D input signal has no effect at the output.

Features

- Contains six flip-flops with single-rail outputs
- Buffered clock and direct clear inputs
- Individual data input to each flip-flop
- Applications include:
 - Buffer/storage registers
 - Shift registers
 - Pattern generators
- Typical clock frequency 40 MHz
- Typical power dissipation per flip-flop 38 mW

Ordering Code:

Order Number	Package Number	Package Description
DM74174	N16E	16-Lead Plastic Dual-In-Line Package (PDIP), JEDEC MS-001, 0.300 Wide

Connection Diagram

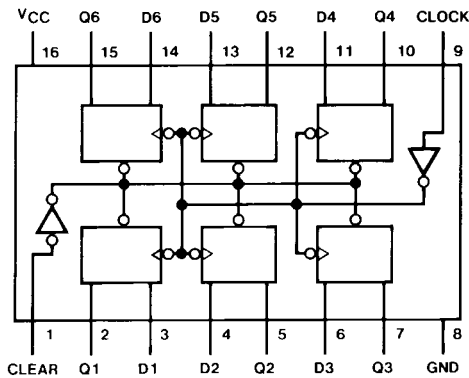

Function Table

(Each Flip-Flop)

Inputs			Outputs
Clear	Clock	D	Q
L	X	X	L
H	↑	H	H
H	↑	L	L
H	L	X	Q ₀

H = HIGH Level (steady state)
L = LOW Level (steady state)
X = Don't Care
↑ = Transition from LOW-to-HIGH level
Q₀ = The level of Q before the indicated steady-state input conditions were established.

DM74174 Hex/Quad D-Type Flip-Flop with Clear

Logic Diagram

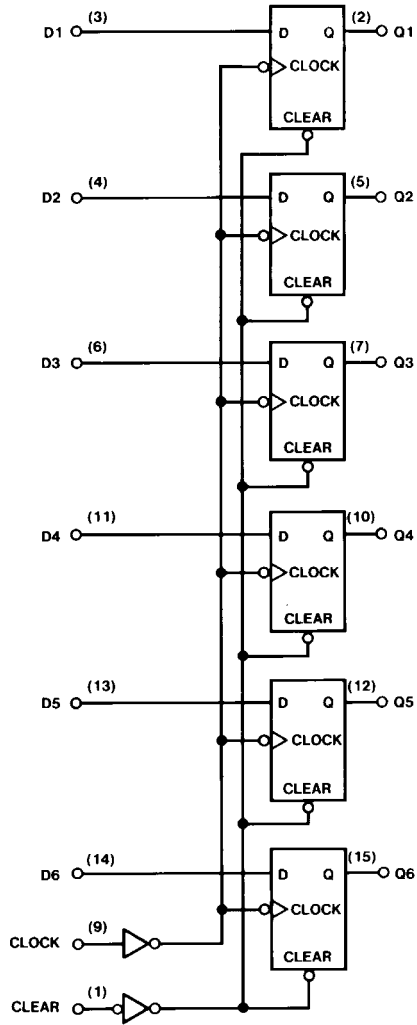

Absolute Maximum Ratings (Note 1)

Supply Voltage	7V
Input Voltage	5.5V
Operating Free Air Temperature Range	0°C to +70°C
Storage Temperature Range	-65°C to +150°C

Note 1: The "Absolute Maximum Ratings" are those values beyond which the safety of the device cannot be guaranteed. The device should not be operated at these limits. The parametric values defined in the Electrical Characteristics tables are not guaranteed at the absolute maximum ratings. The "Recommended Operating Conditions" table will define the conditions for actual device operation.

Recommended Operating Conditions

Symbol	Parameter	Min	Nom	Max	Units
V_{CC}	Supply Voltage	4.75	5	5.25	V
V_{IH}	HIGH Level Input Voltage	2			V
V_{IL}	LOW Level Input Voltage			0.8	V
I_{OH}	HIGH Level Output Current			-0.8	mA
I_{OL}	LOW Level Output Current			16	mA
f_{CLK}	Clock Frequency (Note 2)	0		30	MHz
t_W	Pulse Width (Note 2)	Clock LOW	25		ns
		Clock HIGH	10		
		Clear	20		
t_{SU}	Data Setup Time (Note 2)	20			ns
t_H	Data Hold Time (Note 2)	0			ns
t_{REL}	Clear Release Time (Note 2)	30			ns
T_A	Free Air Operating Temperature	0		70	°C

Note 2: $T_A = 25^\circ\text{C}$ and $V_{CC} = 5\text{V}$.

Electrical Characteristics

over recommended operating free air temperature range (unless otherwise noted)

Symbol	Parameter	Conditions	Min	Typ (Note 3)	Max	Units
V_I	Input Clamp Voltage	$V_{CC} = \text{Min}$, $I_I = -12\text{ mA}$			-1.5	V
V_{OH}	HIGH Level Output Voltage	$V_{CC} = \text{Min}$, $I_{OH} = \text{Max}$ $V_{IL} = \text{Max}$, $V_{IH} = \text{Min}$	2.4			V
V_{OL}	LOW Level Output Voltage	$V_{CC} = \text{Min}$, $I_{OL} = \text{Max}$ $V_{IH} = \text{Min}$, $V_{IL} = \text{Max}$			0.4	V
I_I	Input Current @ Max Input Voltage	$V_{CC} = \text{Max}$, $V_I = 5.5\text{V}$			1	mA
I_{IH}	HIGH Level Input Current	$V_{CC} = \text{Max}$, $V_I = 2.4\text{V}$			40	μA
I_{IL}	LOW Level Input Current	$V_{CC} = \text{Max}$, $V_I = 0.4\text{V}$			-1.6	mA
I_{OS}	Short Circuit Output Current	$V_{CC} = \text{Max}$ (Note 4)	-18		-57	mA
I_{CC}	Supply Current	$V_{CC} = \text{Max}$ (Note 5)		45	65	mA

Note 3: All typicals are at $V_{CC} = 5\text{V}$, $T_A = 25^\circ\text{C}$.

Note 4: Not more than one output should be shorted at a time.

Note 5: With all outputs open and all DATA and CLEAR inputs at 4.5V, I_{CC} is measured after a momentary ground, then 4.5V applied to the CLOCK input.

Switching Characteristics

at $V_{CC} = 5\text{V}$ and $T_A = 25^\circ\text{C}$

Symbol	Parameter	From (Input) To (Output)	$R_L = 400\Omega$, $C_L = 15\text{ pF}$		Units
			Min	Max	
f_{MAX}	Maximum Clock Frequency		30		MHz
t_{PLH}	Propagation Delay Time LOW-to-HIGH Level Output	Clock to Any Q		25	ns
t_{PHL}	Propagation Delay Time HIGH-to-LOW Level Output	Clock to Any Q		25	ns
t_{PHL}	Propagation Delay Time HIGH-to-LOW Level Output	Clear to Any Q		40	ns

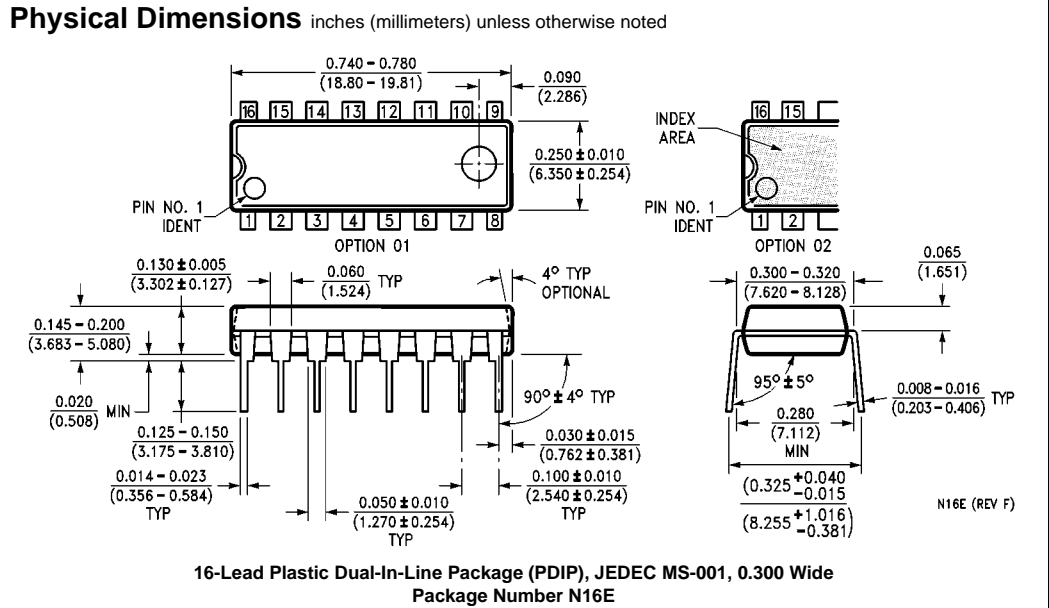

Fairchild does not assume any responsibility for use of any circuitry described, no circuit patent licenses are implied and Fairchild reserves the right at any time without notice to change said circuitry and specifications.

LIFE SUPPORT POLICY

FAIRCHILD'S PRODUCTS ARE NOT AUTHORIZED FOR USE AS CRITICAL COMPONENTS IN LIFE SUPPORT DEVICES OR SYSTEMS WITHOUT THE EXPRESS WRITTEN APPROVAL OF THE PRESIDENT OF FAIRCHILD SEMICONDUCTOR CORPORATION. As used herein:

1. Life support devices or systems are devices or systems which, (a) are intended for surgical implant into the body, or (b) support or sustain life, and (c) whose failure to perform when properly used in accordance with instructions for use provided in the labeling, can be reasonably expected to result in a significant injury to the user.
2. A critical component in any component of a life support device or system whose failure to perform can be reasonably expected to cause the failure of the life support device or system, or to affect its safety or effectiveness.

www.fairchildsemi.com