

Kombi 3^{plus!}

V5000, V5010, V5100 Kombi-3-plus BALANCING AND SHUTOFF VALVES

PRODUCT DATA

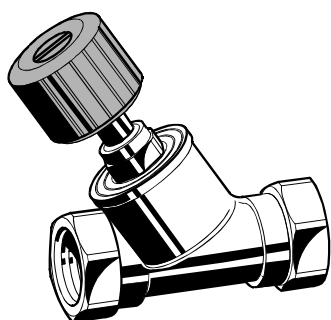

Kombi-3-plus BLACK (V5100)

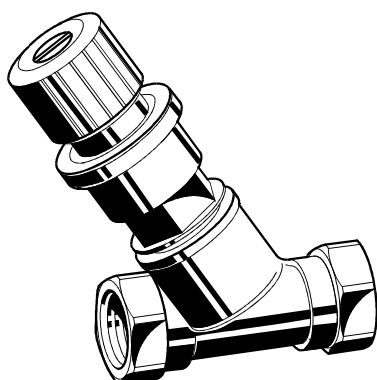

Kombi-3-plus RED (V5000)

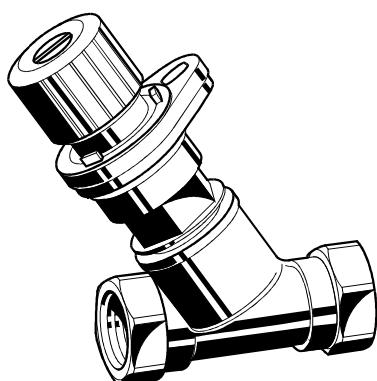

Kombi-3-plus BLUE (V5010)

CONTENTS

Design	2
Materials	2
Application	2
Features	2
Specifications	2
Dimensions	3
Kombi-3-plus BLACK (V5100)	3
Kombi-3-plus RED (V5000)	3
Kombi-3-plus BLUE (V5010).....	4
Ordering Information	5
Accessories	5
Connections	5
Accessories.....	6
Measuring equipment	6
Installation Examples	7
Flow Data Kombi-3-plus RED (V5000)	8
Flow Data Kombi-3-plus RED (V5000) with Measuring Adapter	9
Flow Data Kombi-3-plus BLACK (V5100)	10
Flow Data Kombi-3-plus BLUE (V5010), DN10	11
Flow Data Kombi-3-plus BLUE (V5010), DN15	12
Flow Data Kombi-3-plus BLUE (V5010), DN20	13
Flow Data Kombi-3-plus BLUE (V5010), DN25	14
Flow Data Kombi-3-plus BLUE (V5010), DN32	15
Flow Data Kombi-3-plus BLUE (V5010), DN40	16
Flow Data Kombi-3-plus BLUE (V5010), DN50	17
Flow Data Kombi-3-plus BLUE (V5010), DN65	18
Flow Data Kombi-3-plus BLUE (V5010), DN80	19
Influence of Coolants on Flow Values	20
Correction Factor f	20

Design

- Valve body DN10 to DN20 with internal threads to DIN2999 (ISO7) for threaded pipe or copper and precision steel pipe 10...20 mm (see Accessories), or
- Valve body DN25 to DN80 with internal threads to DIN2999 (ISO7) for threaded pipe, or
- Valve body DN10 to DN50 with external threads to ISO228 for use with connections (see Accessories)
- Valve insert with handwheel
- Pre-setting dial and display (Kombi-3-plus BLUE only)

Materials

- Valve housing made of red bronze
- Valve insert made of brass with seat sealing made of PTFE
- O-rings and soft seals made of EPDM
- Handwheel, pre-setting dial and display made of plastic, black, red or blue and white
- Connection nuts made of brass

Application

The hydronic balance is a significant requirement for the efficient operation of a hydronic heating or cooling installation. In an unbalanced system under or over provision of hot water to individual radiators or circuits can occur. Apart from the correct selection of radiator valves, regulation of individual circuits is also necessary and in some cases, such as in DIN 18 380, VOB part C, is required by national standards. This requirement is met with Kombi-3-plus shutoff and balancing valves.

Kombi-3-plus BLACK for the supply has the functions shutoff, draining and filling (draining adapter required).

Kombi-3-plus RED for the supply additionally supports measuring of the flow and differential pressure.

Kombi-3-plus BLUE for the return has the functions shutoff, draining and filling, pre-setting – together with a Kombi-Diaphragm Unit and a suitable valve in the supply Kombi-3-plus BLUE can be converted into an automatic balancing valve – even after the system has been taken into commission.

Features

- **All functions of the Kombi-3-plus valves can be installed through the spindle**
- **Kombi-3-plus BLUE DN10 to DN40 can be retrofitted with a Kombi-Diaphragm Unit – without interrupting operation of the system**
- **Combination of Kombi-3-plus RED and BLUE allows measuring in the supply and pre-setting in the return – at the same time.**
- **High accuracy of pre-setting because of individual adjustment**
- **Robust valve body made of corrosion resistant red bronze**
- **Available in sizes up to DN80**
- **Visible pre-setting dial with concealed pre-setting wheel (Kombi-3-plus BLUE)**
- **Maintenance free spindle with double O-ring sealings**
- **PTFE seat sealing**

Specifications

Medium	Water, water-glycol mixture
Operating temperature	2...130°C (36...266°F)
Operating pressure	max. 16 bar (232 psi)
Differential pressure	max. 2,0 bar (29 psi) - see NOTE below
k_{vs} (cv)-values	see tables on pages 3 and 4 or flow diagrams

NOTE: Differential pressure: Closing pressure for Kombi-3-plus BLUE with installed Kombi-Diaphragm Unit. Regarding noise generation the conditions, requirements and installation design have to be taken into account.

Dimensions

Kombi-3-plus BLACK (V5100)

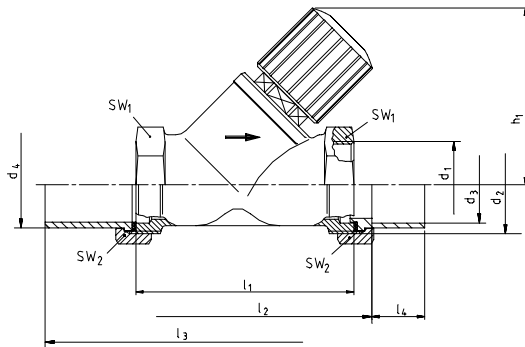

Fig. 1. Kombi-3-plus BLACK

Kombi-3-plus RED (V5000)

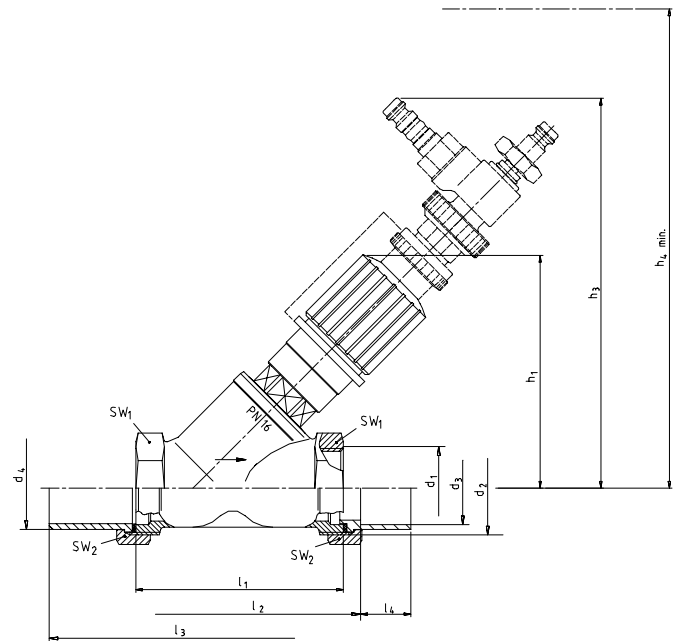

Fig. 2. Kombi-3-plus RED

Table 1. Dimensions Kombi-3-plus BLACK

DN	kvs (cv)-value	h ₁	l ₁	l ₂	l ₃	l ₄	d ₁	d ₂	d ₃	d ₄	SW ₁	SW ₂
10	2,5 (2,93)	60	60	74	110	10	Rp3/8"	G5/8"A	12	16	22	27
15	2,5 (2,93)	65	65	81	125	12	Rp1/2"	G3/4"A	15	20,5	27	30
20	7,0 (8,19)	70	75	92	146	17	Rp3/4"	G1"A	22	26	32	37
25	7,0 (8,19)	72	90	108	170	20	Rp1"	G1 1/4"A	28	33	41	47
32	22,0 (25,7)	120	110	128	200	25	Rp1 1/4"	G1 1/2"A	35	41	50	52
40	22,0 (25,7)	120	120	140	220	29	Rp1 1/2"	G1 3/4"A	42	47,5	55	60

Table 2. Dimensions Kombi-3-plus RED

DN	kvs (cv)-value	h ₁	h ₃	h ₄	h ₅	h ₆	l ₁	l ₂	l ₃	l ₄	d ₁	d ₂	d ₃	d ₄	SW ₁	SW ₂
10	1,5 (1,76)	85	145	195	135	130	60	74	110	10	Rp3/8"	G5/8"A	12	16	22	27
15	2,5 (2,93)	85	145	195	135	130	65	81	125	12	Rp1/2"	G3/4"A	15	20,5	27	30
20	4,5 (5,27)	100	160	210	150	145	75	92	146	17	Rp3/4"	G1"A	22	26	32	37
25	6,5 (7,61)	100	160	210	150	145	90	108	170	20	Rp1"	G1 1/4"A	28	33	41	47
32	13,0 (15,2)	137	195	280	185	210	110	128	200	25	Rp1 1/4"	G1 1/2"A	35	41	50	52
40	20,0 (23,4)	137	195	280	185	210	120	140	220	29	Rp1 1/2"	G1 3/4"A	42	47,5	55	60
50	35,0 (41,0)	158	215	300	205	230	150	170	260	34	Rp2"	G2 3/8"A	54	60	70	75
65	42,0 (49,1)	195	225	310	215	-	180	-	-	-	Rp2 1/2"	-	-	-	85	-
80	68,0 (79,6)	210	240	325	230	-	200	-	-	-	Rp3"	-	-	-	100	-

NOTE: All dimensions in mm if not stated otherwise.

Kombi-3-plus BLUE (V5010)

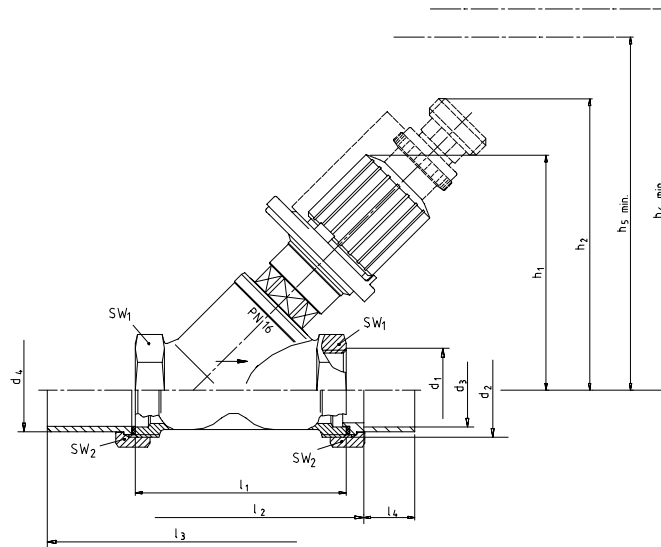

Fig. 3. Kombi-3-plus BLUE

Table 3. Dimensions Kombi-3-plus BLUE

DN	kvs (cv)-value	h ₁	h ₂	h ₃	h ₆	l ₁	l ₂	l ₃	l ₄	d ₁	d ₂	d ₃	d ₄	SW ₁	SW ₂
10	2,4 (2,81)	85	105	135	130	60	74	110	10	Rp3/8"	G5/8"A	12	16	22	27
15	2,7 (3,16)	85	105	135	130	65	81	125	12	Rp1/2"	G3/4"A	15	20,5	27	30
20	6,4 (7,49)	100	120	150	145	75	92	146	17	Rp3/4"	G1"A	22	26	32	37
25	6,8 (7,96)	100	120	150	145	90	108	170	20	Rp1"	G1 1/4"A	28	33	41	47
32	21,0 (24,6)	137	155	185	210	110	128	200	25	Rp1 1/4"	G1 1/2"A	35	41	50	52
40	22,0 (25,7)	137	155	185	210	120	140	220	29	Rp1 1/2"	G1 3/4"A	42	47,5	55	60
50	38,0 (44,5)	158	176	205	230	150	170	260	34	Rp2"	G2 3/8"A	54	60	70	75
65	47,7 (55,8)	195	186	215	-	180	-	-	-	Rp2 1/2"	-	-	-	85	-
80	71,0 (83,1)	210	201	230	-	200	-	-	-	Rp3"	-	-	-	100	-

NOTE: All dimensions in mm if not stated otherwise.

Table 4. Abbreviations used for dimensions

DN	Nominal size	h₅	Clearance required to fit draining adapter
d₁	Internal thread on body (connection size)	h₆	Clearance required to fit tamper-proof cap
d₂	External thread on body	l₁	Body length according to DIN3502
d₃	Inner Ø of connection	l₂	Installed length with soldering connections
d₄	Outer Ø of connection	l₃	Installed length with welding connections
h₁	Height with valve fully open	l₄	Length of pipe penetration
h₂	Height with installed draining adapter	SW₁	Wrench size
h₃	Height with installed measuring adapter	SW₂	Wrench size
h₄	Clearance required to fit measuring adapter		

Ordering Information

Complete OS-No. with desired dimension, e.g. 'V5000X' in DN25 has OS-No. 'V5000X0025'

Type	OS-No. DN Rp	10 3/8"	15 1/2"	20 3/4"	25 1"	32 1 1/4"	40 1 1/2"	50 2"	65 2 1/2"	80 3"
Kombi-3-plus BLACK, internal threads	V5100Y	0010	0015	0020	0025	0032	0040	—	—	—
Kombi-3-plus BLACK, external threads	V5100X	0010	0015	0020	0025	0032	0040	—	—	—
Kombi-3-plus RED, internal threads	V5000Y	0010	0015	0020	0025	0032	0040	0050	0065	0080
Kombi-3-plus RED, external threads	V5000X	0010	0015	0020	0025	0032	0040	0050	—	—
Kombi-3-plus BLUE, internal threads	V5010Y	0010	0015	0020	0025	0032	0040	0050	0065	0080
Kombi-3-plus BLUE, external threads	V5010X	0010	0015	0020	0025	0032	0040	0050	—	—

Accessories

Connections

Set of compression ring and nut

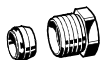

3/8" x 10 mm	VA650A1010
3/8" x 12 mm	VA650A1012
1/2" x 10 mm	VA650A1210
1/2" x 12 mm	VA650A1212
1/2" x 14 mm	VA650A1214
1/2" x 15 mm	VA650A1215
1/2" x 16 mm	VA650A1216
3/4" x 18 mm	VA650A2018
3/4" x 22 mm	VA650A2022

NOTE: Support inserts have to be used for soft copper and steel pipe (wall thickness 1 mm).

Set of compression ring, nut and support insert (2 pcs each)



3/8" x 12 mm	VA651A1012
1/2" x 12 mm	VA651A1212
1/2" x 15 mm	VA651A1215
1/2" x 16 mm	VA651A1216
3/4" x 18 mm	VA651A2018

Soldering connection made of brass



12 mm, for valves DN10	VA5530A010
15 mm, for valves DN15	VA5530A015
22 mm, for valves DN20	VA5530A020
28 mm, for valves DN25	VA5530A025
35 mm, for valves DN32	VA5530A032
42 mm, for valves DN40	VA5530A040
54 mm, for valves DN50	VA5530A050

Welding connection made of steel

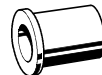

for valves DN10	VA5540A010
for valves DN15	VA5540A015
for valves DN20	VA5540A020
for valves DN25	VA5540A025
for valves DN32	VA5540A032
for valves DN40	VA5540A040
for valves DN50	VA5540A050

Externally threaded connection made of brass

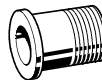

3/8", for valves DN10	VA5500A010
1/2", for valves DN15	VA5500A015
3/4", for valves DN20	VA5500A020
1", for valves DN25	VA5500A025
1 1/4", for valves DN32	VA5500A032
1 1/2", for valves DN40	VA5500A040
2", for valves DN50	VA5500A050

Sealing ring



3/8", for valves DN10	VA5090A010
1/2", for valves DN15	VA5090A015
3/4", for valves DN20	VA5090A020
1", for valves DN25	VA5090A025
1 1/4", for valves DN32	VA5090A032
1 1/2", for valves DN40	VA5090A040
2", for valves DN50	VA5090A050

Accessories

Kombi-Diaphragm Unit

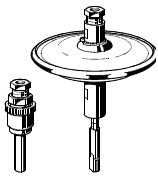

Setting range 0,1...0,3 bar
(1,45...4,35 psi) differential
pressure;

V5012A0103

for Kombi-3-plus BLUE
DN10...DN40

Setting range 0,3...0,6 bar
(4,35...8,7 psi) differential
pressure;

V5012A0306

for Kombi-3-plus BLUE
DN10...DN40

NOTE: For product information and diagrams see product data sheet 'Kombi-DU Diaphragm Unit'.
The Kombi-3-plus BLUE valve must be pre-set to 1.5 (for DN10...25) or 1.0 (DN32...40) when used with the Kombi-DU Diaphragm Unit.
Pump pressure: max. 2 bar (29 psi)

Draining adapter

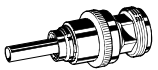

for all types and sizes

VA3500A001

Tamper-proof cap

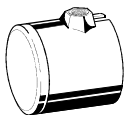

for valves DN15...DN25

VA2501A010

for valves DN32...DN50

VA2501A032

Adapter for actuators with M30 x 1,5 connection

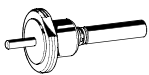

for Kombi-3-plus BLUE
DN10...DN40

VA2500A001

Flow values for Kombi-3-plus BLUE with installed adapter:

DN	10	15	20	25	32	40
k_{vs}-value	1,50	1,50	3,50	3,50	5,50	5,50
cv-value	1,76	1,76	4,10	4,10	6,44	6,44

NOTE: The Kombi-3-plus BLUE valve must be pre-set to 1.5 (for DN10...25) or 1.0 (DN32...40) when used with actuator.

Actuator adapter can only be used with DN10 valve housings with 'H' marking (valve housings since 10/1999).

Pump pressure: max. 2 bar (29 psi)

Measuring equipment

Pressure measuring set

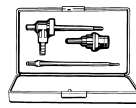

for all Kombi-3-plus RED

VA3502A001

Flow meter



for all Kombi-3-plus RED

VM200A1001

'BasicMES' handheld measuring computer



for all Kombi-3-plus RED;
computer is supplied with
case and accessories

VM241A1002

Installation Examples

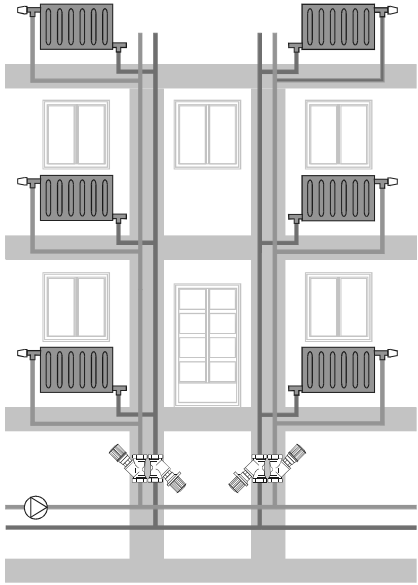

Fig. 4. Kombi-3-plus RED and BLUE in risers

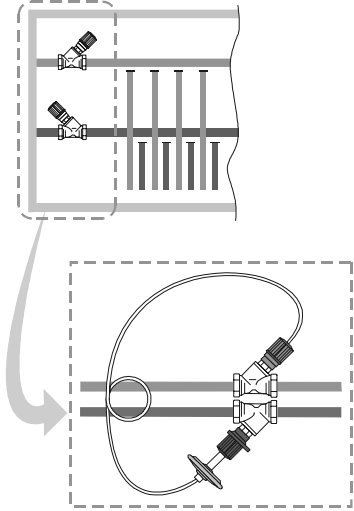

Fig. 6. Kombi-3-plus in a distribution manifold

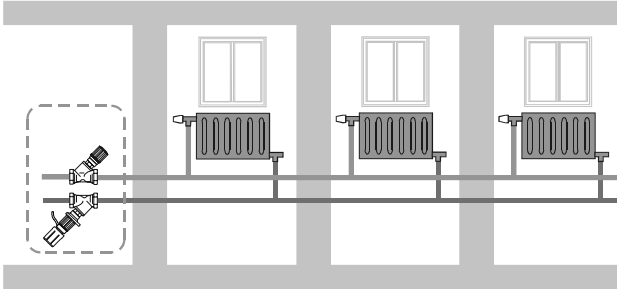

Fig. 5. Zone control with Kombi-3-plus and an actuator

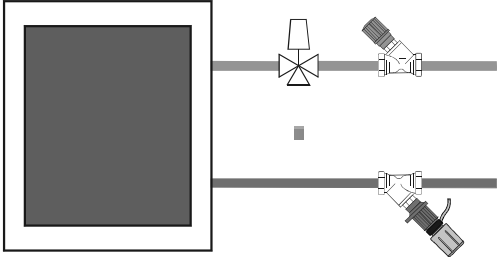
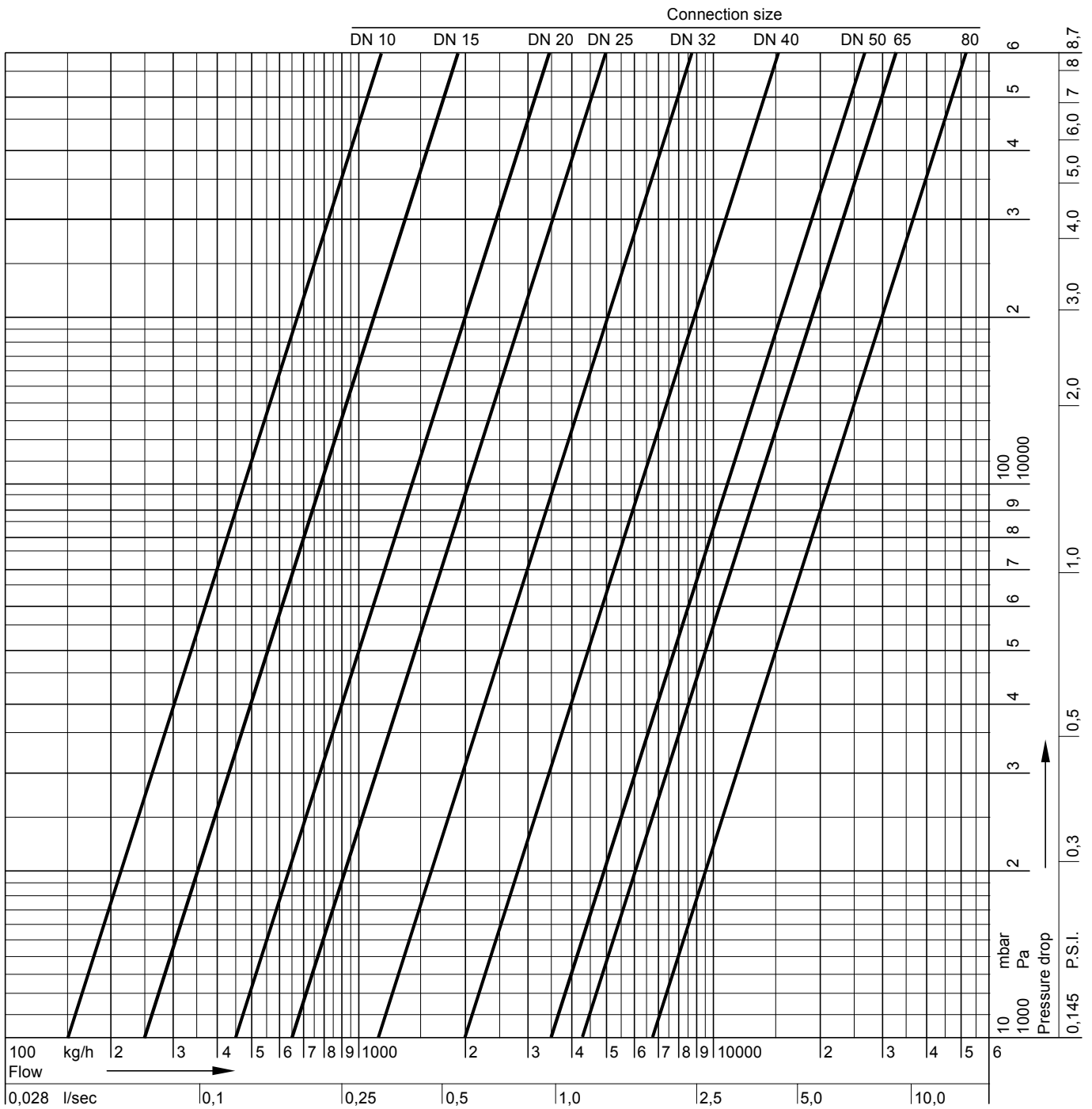

Fig. 7. Kombi-3-plus in an air heater/fan coil unit

Flow Data Kombi-3-plus RED (V5000)



DN	10	15	20	25	32	40	50	65	80
kvs-value	1,50	2,50	4,50	6,50	13,0	20,0	35,0	42,0	68,0
cv-value	1,76	2,93	5,27	7,61	15,2	23,4	41,0	49,1	80,0

Flow Data Kombi-3-plus RED (V5000) with Measuring Adapter

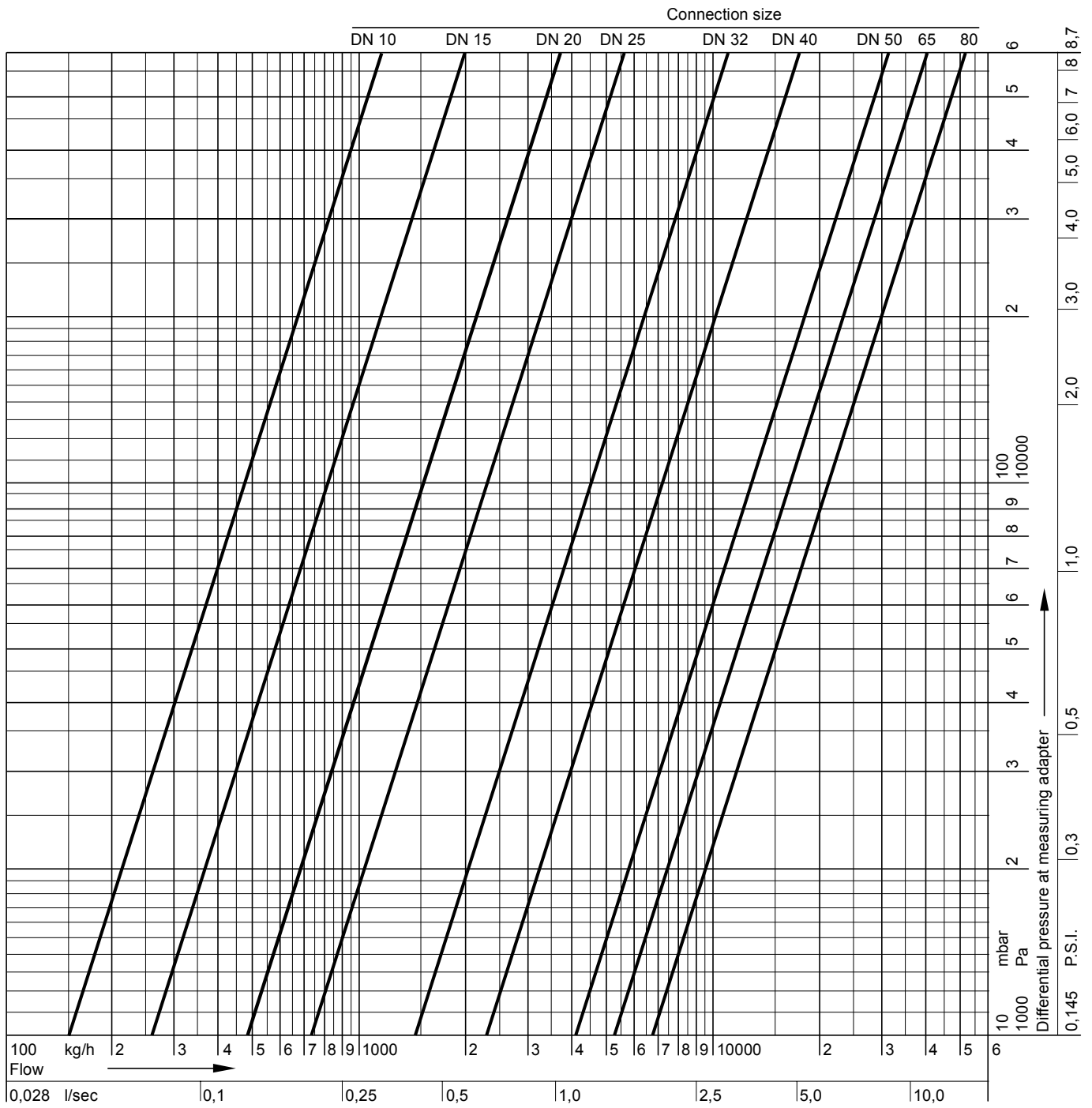

DN	10	15	20	25	32	40	50	65	80
kvs-value	1,55	2,65	4,88	7,30	14,5	23,0	41,0	53,0	68,0
cv-value	1,81	3,10	5,71	8,54	17,0	26,9	48,0	62,0	80,0

Flow Data Kombi-3-plus BLACK (V5100)

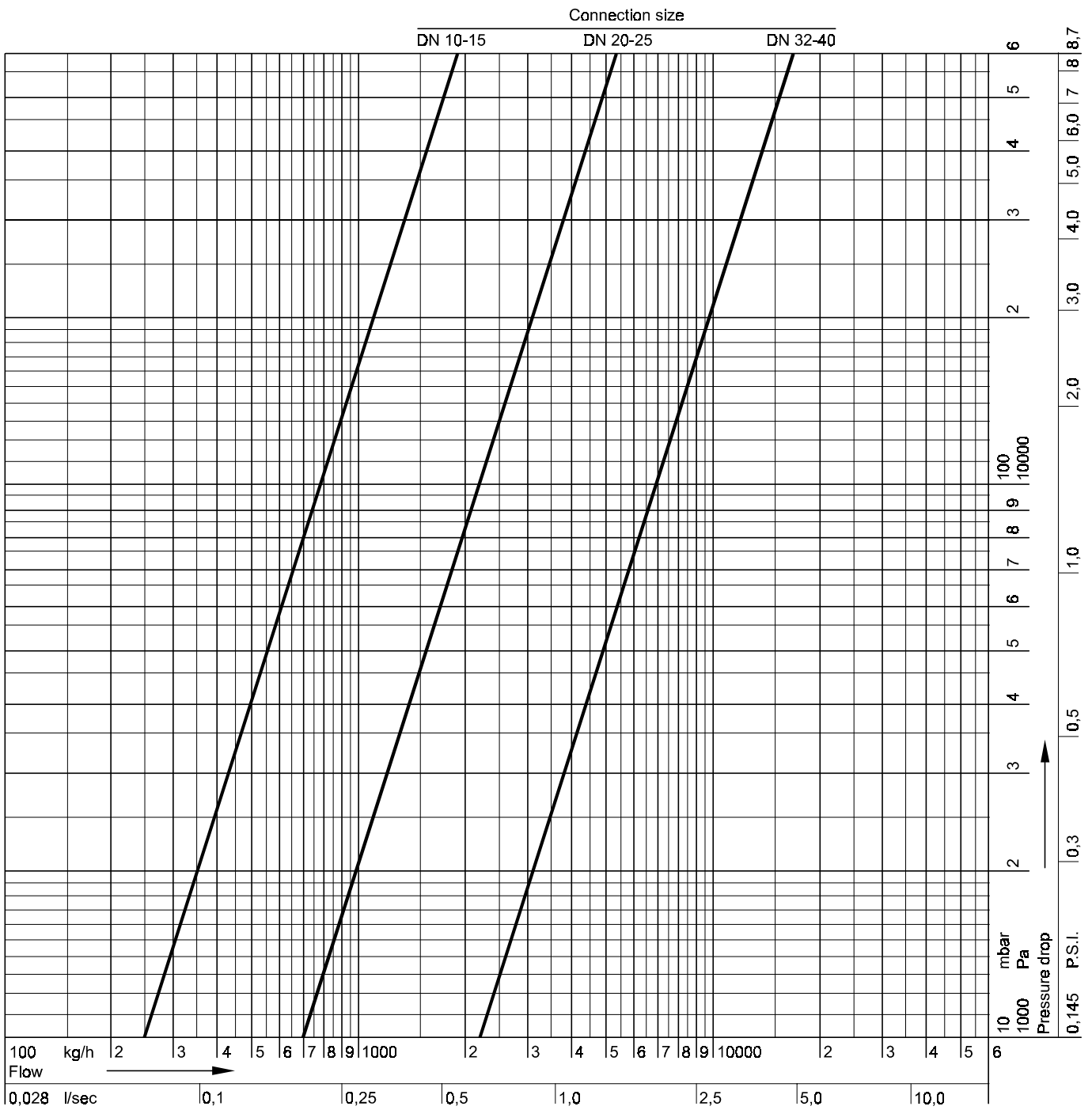

DN	10	15	20	25	32	40
kvs-value	2,50	2,50	7,00	7,00	22,0	22,0
cv-value	2,93	2,93	8,19	8,19	25,7	25,7

Flow Data Kombi-3-plus BLUE (V5010), DN10

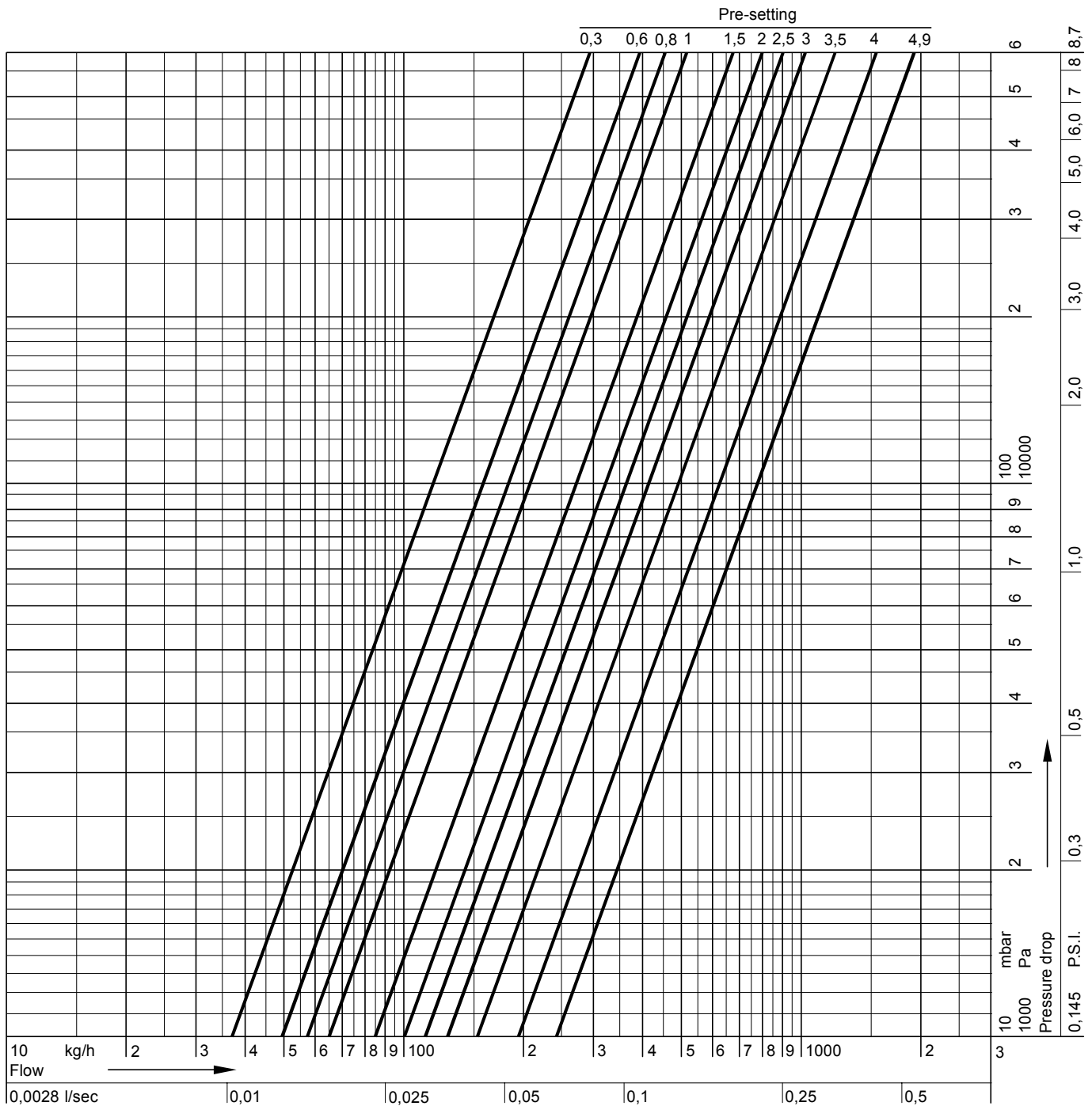

Pre-setting	0,3	0,4	0,6	0,8	1,0	1,2	1,4	1,6	1,8	2,0	2,2	2,4	2,6	2,8	3,0	3,2	3,4	3,6
k _v -value	0,37	0,43	0,49	0,57	0,65	0,73	0,81	0,88	0,94	1,00	1,05	1,10	1,16	1,22	1,30	1,39	1,50	1,63
cv-value	0,43	0,50	0,57	0,67	0,76	0,85	0,95	1,03	1,10	1,17	1,23	1,29	1,36	1,43	1,52	1,63	1,76	1,91

Pre-setting	3,8	4,0	4,2	4,4	4,6	4,8	4,9 = open
k _v -value	1,77	1,92	2,07	2,21	2,32	2,39	k _{vs} = 2,40
cv-value	2,07	2,25	2,42	2,59	2,71	2,80	2,81

NOTE: Flow diagram is ONLY valid for valve WITHOUT installed actuator (-adapter) or Kombi-Diaphragm Unit

Flow Data Kombi-3-plus BLUE (V5010), DN15

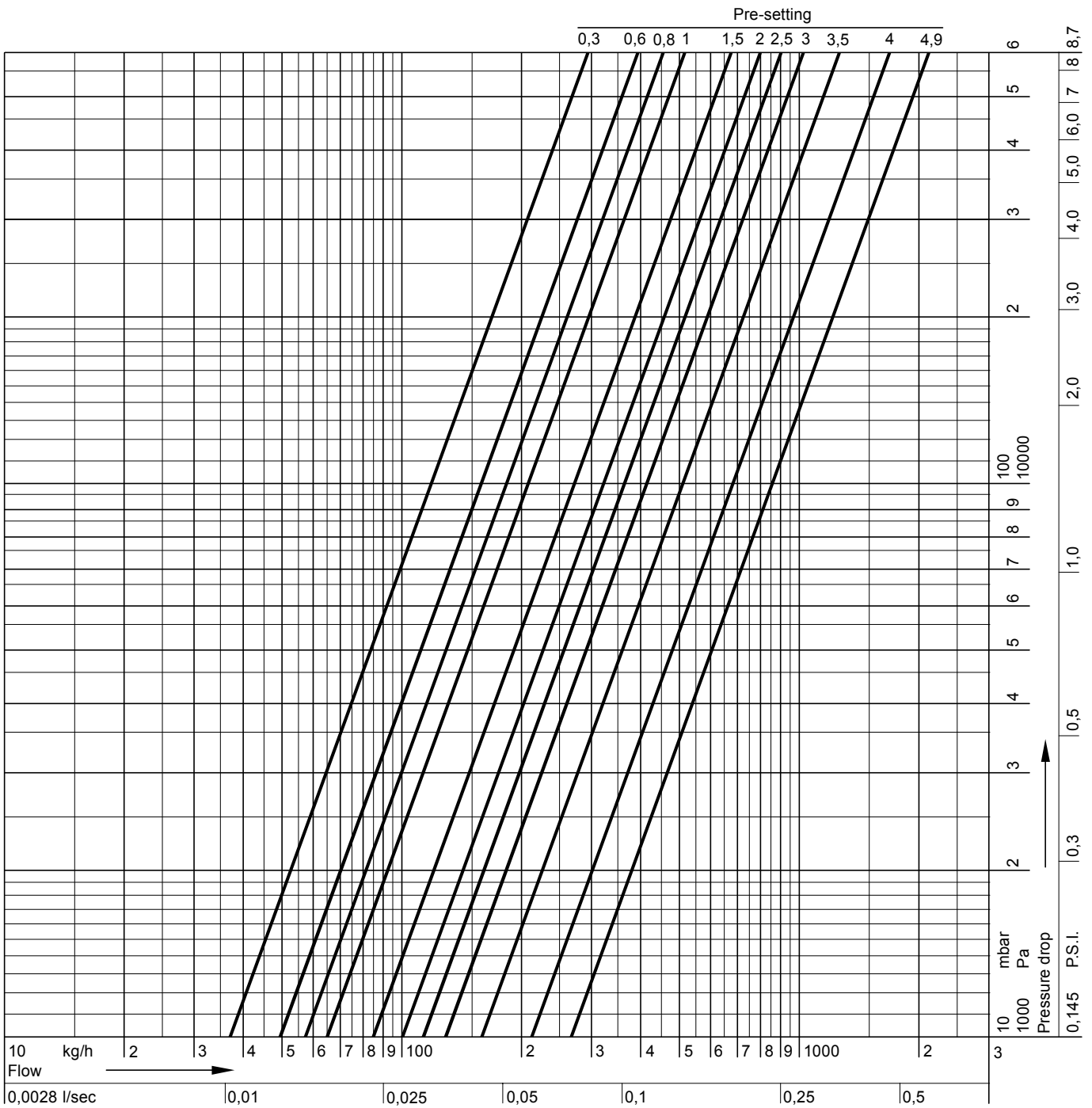

Pre-setting	0,3	0,4	0,6	0,8	1,0	1,2	1,4	1,6	1,8	2,0	2,2	2,4	2,6	2,8	3,0	3,2	3,4	3,6
k_v-value	0,37	0,43	0,49	0,57	0,65	0,73	0,81	0,88	0,94	1,00	1,05	1,10	1,16	1,22	1,32	1,42	1,57	1,74
cv-value	0,43	0,50	0,57	0,67	0,76	0,85	0,95	1,03	1,10	1,17	1,23	1,29	1,36	1,43	1,54	1,66	1,84	2,04

Pre-setting	3,8	4,0	4,2	4,4	4,6	4,8	4,9 = open
k_v-value	1,92	2,12	2,31	2,49	2,63	2,67	k _{vs} = 2,70
cv-value	2,25	2,48	2,70	2,91	3,08	3,12	3,16

NOTE: Flow diagram is ONLY valid for valve WITHOUT installed actuator (-adapter) or Kombi-Diaphragm Unit

Flow Data Kombi-3-plus BLUE (V5010), DN20

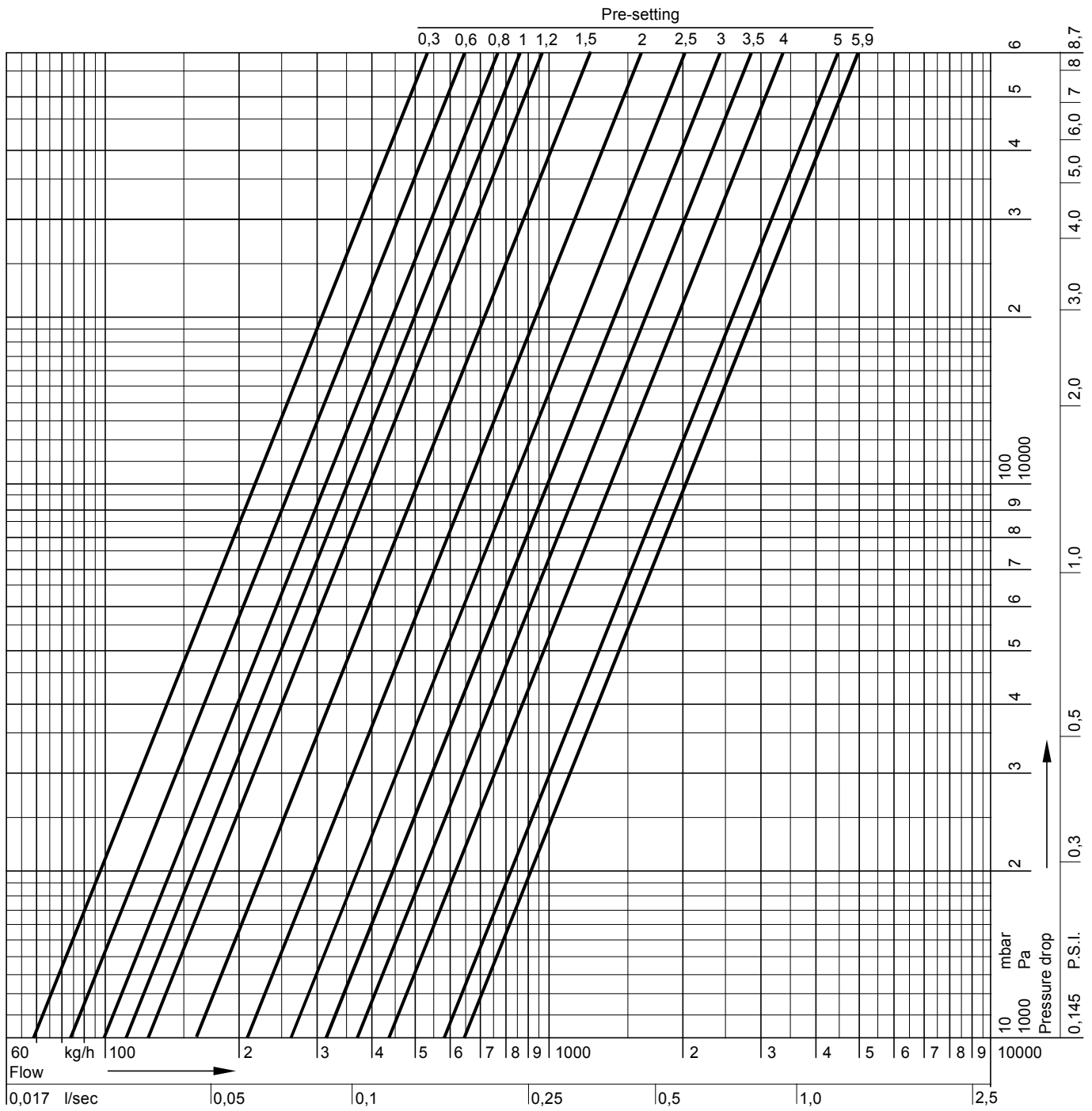

Pre-setting	0,3	0,4	0,6	0,8	1,0	1,2	1,4	1,6	1,8	2,0	2,2	2,4	2,6	2,8	3,0	3,2	3,4	3,6
k_v-value	0,68	0,72	0,84	0,97	1,10	1,30	1,50	1,70	1,90	2,10	2,30	2,50	2,70	2,91	3,12	3,36	3,60	3,86
cv-value	0,80	0,84	0,98	1,13	1,29	1,52	1,76	1,99	2,22	2,46	2,69	2,93	3,16	3,40	3,65	3,93	4,21	4,52

Pre-setting	3,8	4,0	4,2	4,4	4,6	4,8	5,0	5,2	5,4	5,6	5,8	5,9 = open
k_v-value	4,12	4,40	4,69	4,99	5,28	5,57	5,84	6,07	6,26	6,32	6,38	k _{vs} = 6,40
cv-value	4,82	5,15	5,49	5,84	6,18	6,52	6,83	7,10	7,32	7,39	7,46	7,49

NOTE: Flow diagram is ONLY valid for valve WITHOUT installed actuator (-adapter) or Kombi-Diaphragm Unit

Flow Data Kombi-3-plus BLUE (V5010), DN25

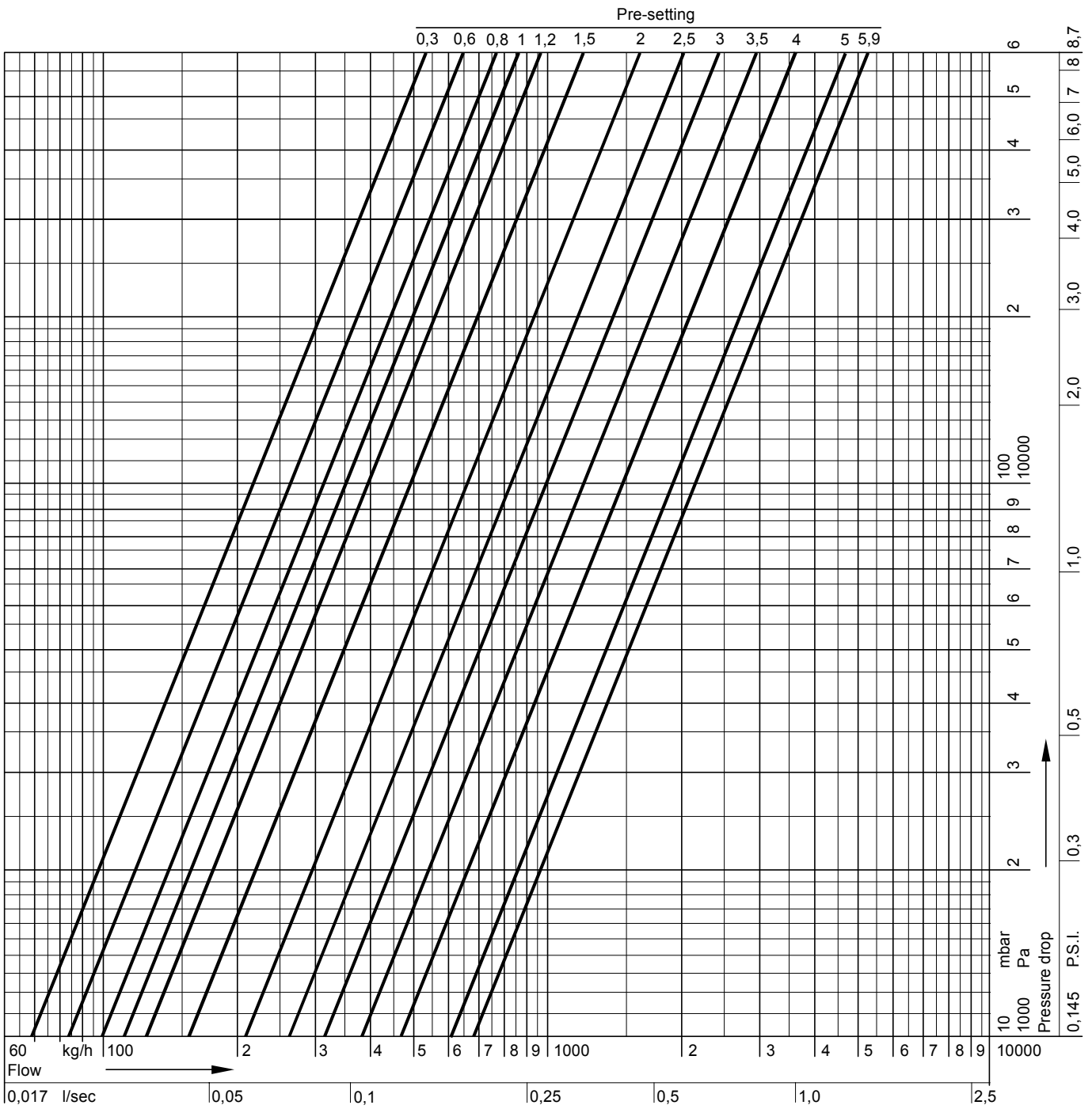

Pre-setting	0,3	0,4	0,6	0,8	1,0	1,2	1,4	1,6	1,8	2,0	2,2	2,4	2,6	2,8	3,0	3,2	3,4	3,6
k_v-value	0,68	0,72	0,84	0,97	1,10	1,30	1,50	1,70	1,90	2,10	2,30	2,50	2,70	2,95	3,20	3,48	3,76	4,05
cv-value	0,80	0,84	0,98	1,13	1,29	1,52	1,76	1,99	2,22	2,46	2,69	2,93	3,16	3,45	3,74	4,07	4,40	4,74

Pre-setting	3,8	4,0	4,2	4,4	4,6	4,8	5,0	5,2	5,4	5,6	5,8	5,9 = open
k_v-value	4,34	4,64	4,94	5,24	5,52	5,80	6,06	6,30	6,50	6,65	6,75	k _{vs} = 6,80
cv-value	5,08	5,43	5,78	6,13	6,46	6,79	7,09	7,37	7,61	7,78	7,90	7,96

NOTE: Flow diagram is ONLY valid for valve WITHOUT installed actuator (-adapter) or Kombi-Diaphragm Unit

Flow Data Kombi-3-plus BLUE (V5010), DN32

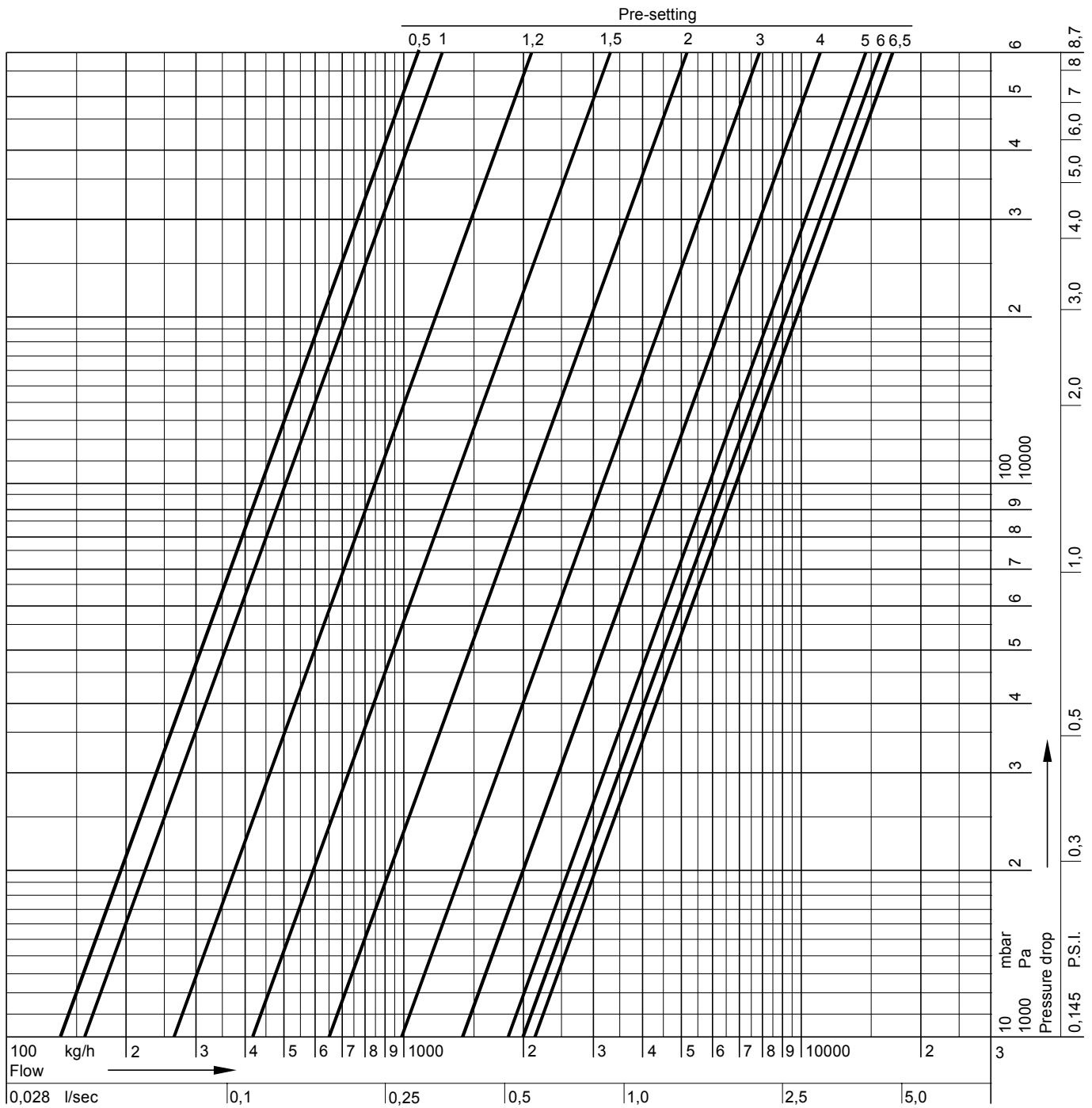

Pre-setting	0,5	0,6	0,8	1,0	1,2	1,4	1,6	1,8	2,0	2,2	2,4	2,6	2,8	3,0	3,2	3,4	3,6	3,8
k _v -value	1,40	1,45	1,55	1,60	2,60	3,70	4,80	5,90	6,50	6,90	7,50	8,30	9,20	10,2	11,2	12,2	13,2	14,1
cv-value	1,64	1,70	1,81	1,87	3,04	4,33	5,62	6,90	7,61	8,07	8,78	9,71	10,8	11,9	13,1	14,3	15,4	16,5

Pre-setting	4,0	4,2	4,4	4,6	4,8	5,0	5,2	5,4	5,6	5,8	6,0	6,2	6,4	6,5 = open
k _v -value	15,0	15,8	16,5	17,1	17,7	18,2	18,6	19,0	19,4	19,7	20,0	20,4	20,8	k _{vs} = 21,0
cv-value	17,6	18,5	19,3	20,0	20,7	21,3	21,8	22,2	22,7	23,0	23,4	23,9	24,3	24,6

NOTE: Flow diagram is ONLY valid for valve WITHOUT installed actuator (-adapter) or Kombi-Diaphragm Unit

Flow Data Kombi-3-plus BLUE (V5010), DN40

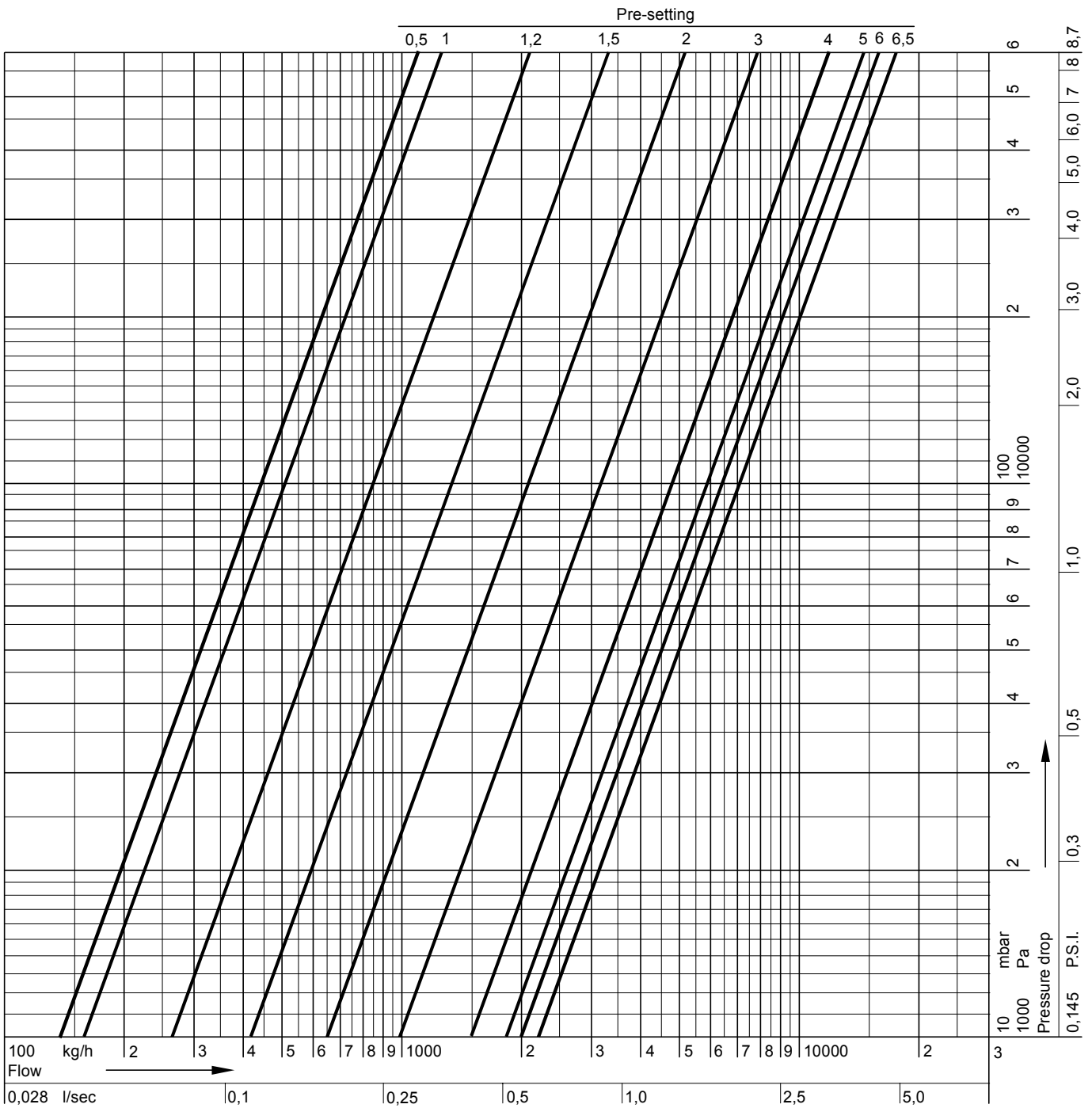

Pre-setting	0,5	0,6	0,8	1,0	1,2	1,4	1,6	1,8	2,0	2,2	2,4	2,6	2,8	3,0	3,2	3,4	3,6	3,8
k_v-value	1,40	1,45	1,55	1,60	2,60	3,70	4,80	5,90	6,50	6,90	7,50	8,30	9,20	10,2	11,2	12,2	13,2	14,1
cv-value	1,64	1,70	1,81	1,87	3,04	4,33	5,62	6,90	7,61	8,07	8,78	9,71	10,8	11,9	13,1	14,3	15,4	16,5

Pre-setting	4,0	4,2	4,4	4,6	4,8	5,0	5,2	5,4	5,6	5,8	6,0	6,2	6,4	6,5 = open
k_v-value	15,0	15,8	16,5	17,1	17,7	18,2	18,6	19,0	19,4	19,7	20,0	20,8	21,6	k _{vs} = 22,0
cv-value	17,6	18,5	19,3	20,0	20,7	21,3	21,8	22,2	22,7	23,0	23,4	24,3	25,3	25,7

NOTE: Flow diagram is ONLY valid for valve WITHOUT installed actuator (-adapter) or Kombi-Diaphragm Unit

Flow Data Kombi-3-plus BLUE (V5010), DN50

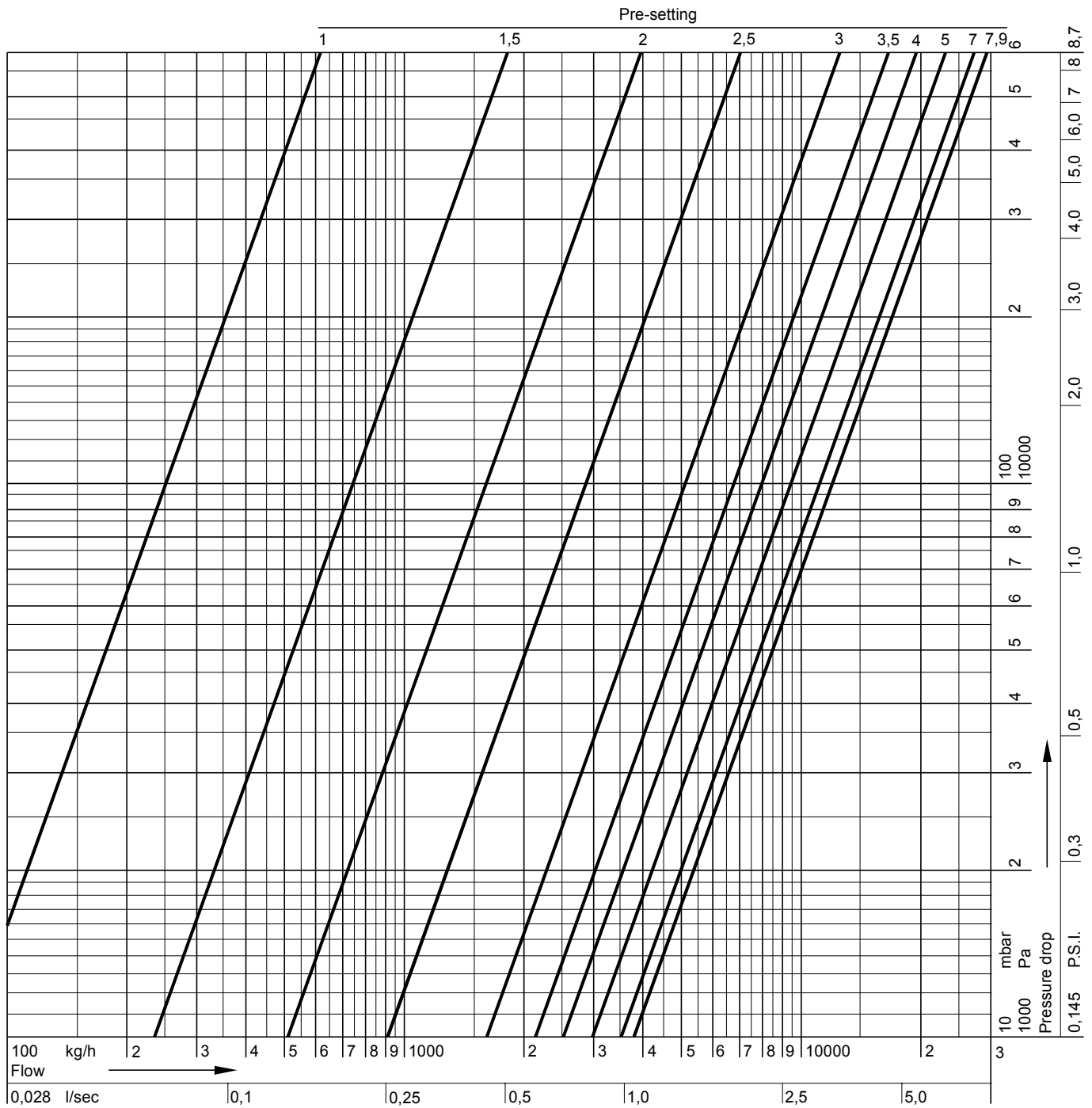

Pre-setting	1,0	1,2	1,4	1,6	1,8	2,0	2,2	2,4	2,6	2,8	3,0	3,2	3,4	3,6	3,8	4,0	4,2	4,4
k_v-value	0,80	1,25	1,88	2,72	3,78	5,10	6,68	8,54	10,7	13,0	15,6	18,7	21,0	22,8	24,3	25,4	26,4	27,2
cv-value	0,94	1,46	2,20	3,18	4,42	5,97	7,82	9,99	12,5	15,2	18,3	21,9	24,6	26,7	28,4	29,7	30,9	31,8

Pre-setting	4,6	4,8	5,0	5,2	5,4	5,6	5,8	6,0	6,2	6,4	6,6	6,8	7,0	7,2	7,4	7,6	7,9 = open
k_v-value	28,0	28,8	29,5	30,2	31,0	31,7	32,4	33,0	33,6	34,1	34,6	35,0	35,4	35,8	36,2	36,8	k _{vs} = 38,0
cv-value	32,8	33,7	34,5	35,3	36,3	37,1	37,9	38,6	39,3	39,9	40,5	41,0	41,4	41,9	42,4	43,1	44,5

Flow Data Kombi-3-plus BLUE (V5010), DN65

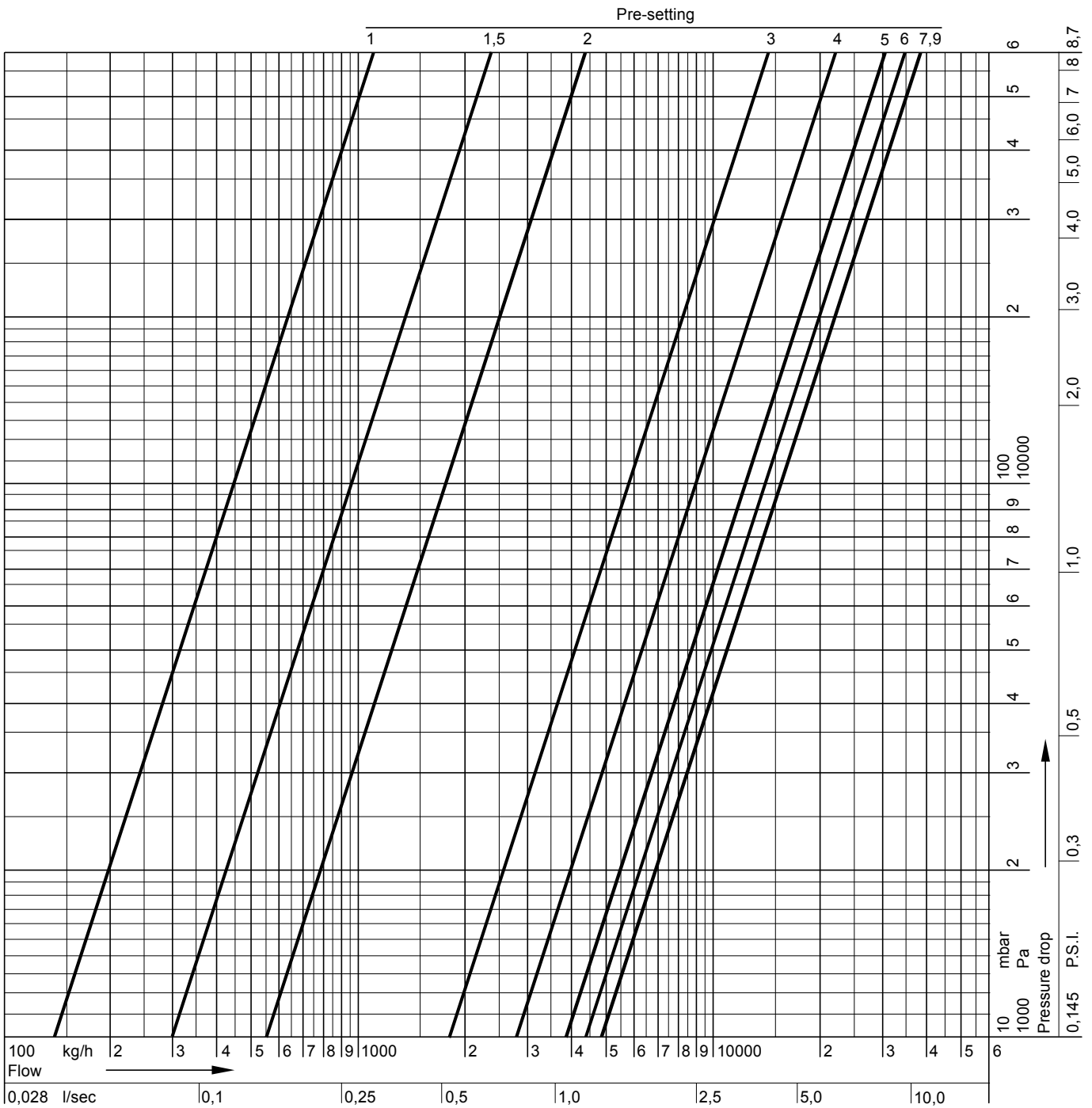

Pre-setting	1,0	1,2	1,4	1,6	1,8	2,0	2,2	2,4	2,6	2,8	3,0	3,2	3,4	3,6	3,8	4,0	4,2	4,4
k _v -value	1,40	1,50	2,50	3,50	4,50	5,50	7,70	10,0	12,2	14,5	16,7	19,0	21,3	23,7	26,0	28,3	30,1	31,9
cv-value	1,64	1,76	2,93	4,10	5,27	6,44	9,01	11,7	14,3	17,0	19,5	22,2	24,9	27,7	30,4	33,1	35,2	37,3

Pre-setting	4,6	4,8	5,0	5,2	5,4	5,6	5,8	6,0	6,2	6,4	6,6	6,8	7,0	7,2	7,4	7,6	7,9 = open
k _v -value	33,6	35,4	37,2	38,6	40,1	41,5	43,0	44,0	44,9	45,4	46,0	46,5	47,0	47,1	47,3	47,4	k _{vs} = 47,7
cv-value	39,3	41,4	43,5	45,2	46,9	48,6	50,3	51,5	52,5	53,1	53,8	54,4	55,0	55,0	55,3	55,5	55,8

Flow Data Kombi-3-plus BLUE (V5010), DN80

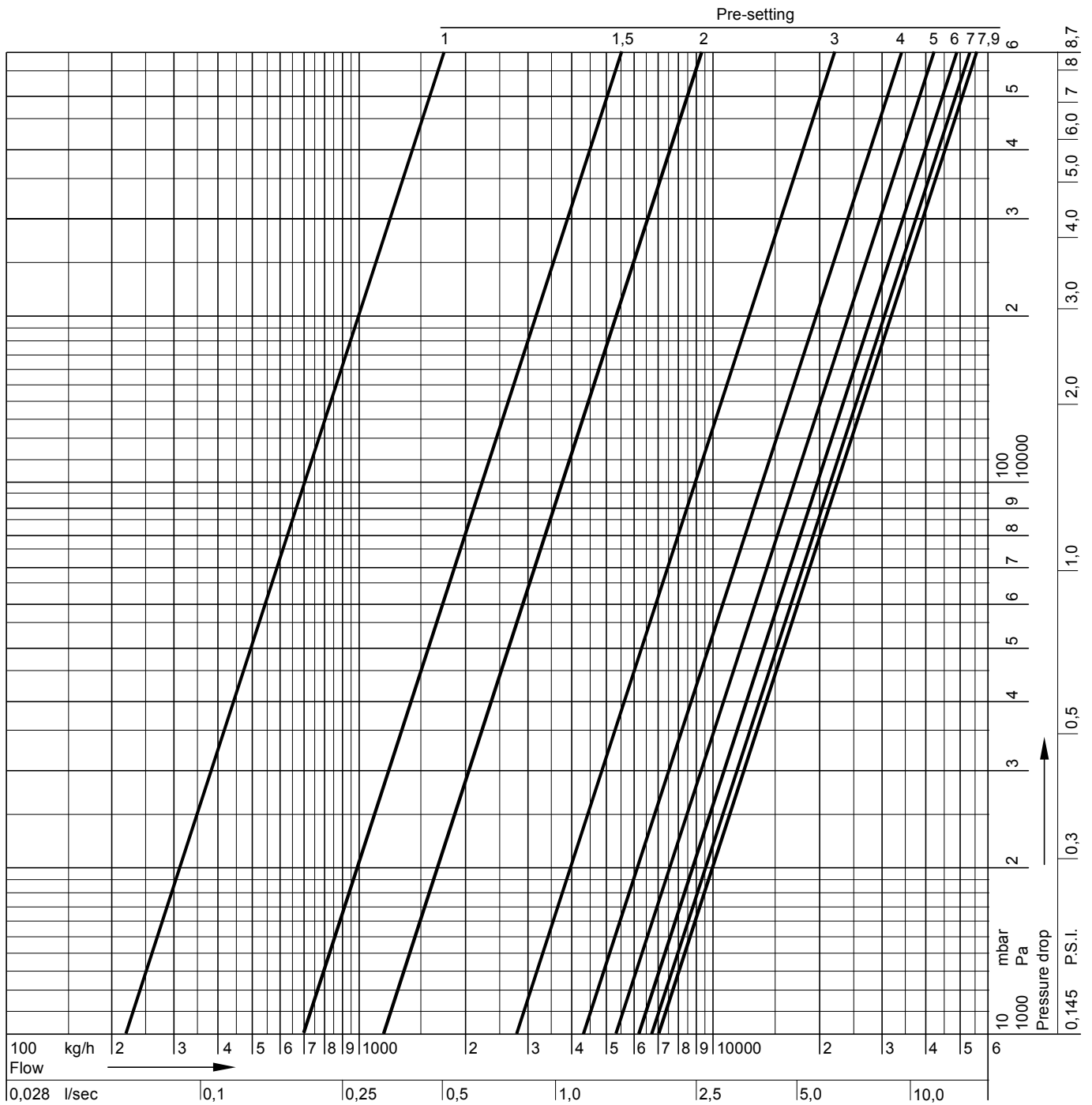

Pre-setting	1,0	1,2	1,4	1,6	1,8	2,0	2,2	2,4	2,6	2,8	3,0	3,2	3,4	3,6	3,8	4,0	4,2	4,4
k_v-value	2,20	4,20	6,20	8,10	10,1	12,1	15,3	18,5	21,6	24,8	28,0	30,9	33,9	36,8	39,8	42,7	44,9	47,0
k_v-value	2,57	4,91	7,25	9,48	11,8	14,2	17,9	21,6	25,3	29,0	32,8	36,1	39,7	43,1	46,6	50,0	52,5	55,0
Pre-setting	4,6	4,8	5,0	5,2	5,4	5,6	5,8	6,0	6,2	6,4	6,6	6,8	7,0	7,2	7,4	7,6	7,9 = open	
k_v-value	49,2	51,3	53,5	55,2	57,0	58,7	60,5	62,2	63,4	64,5	65,7	66,8	68,0	68,6	69,2	69,8	k _{vs} = 71,0	
k_v-value	57,6	60,0	62,6	64,6	66,7	68,7	70,8	72,8	74,2	75,5	76,9	78,2	79,6	80,3	81,0	81,7	83,1	

Influence of Coolants on Flow Values

The flow through a valve is defined by the k_v -value. The k_v -value is the flow m through a valve in [m³/h] at a differential pressure of 1 bar (14,5 P.S.I.) and is only valid for fluids with a density of $\rho_0 = 1000 \text{ kg/m}^3$. This condition is met by water at a temperature of 20°C (68°F). For fluids with another density the following formula can be applied:

$$K_{V_{Medium}} = \frac{m}{\sqrt{\Delta p}} \times \frac{\sqrt{\rho_{Medium}}}{\sqrt{\rho_0}}$$

Correction Factor f

When the density σ is expressed in t/m³ instead of kg/m³ the correction factor f is the result. The correction factor f can be used to re-calculate k_v -value, pressure drop and flow:

$$K_{V_{Medium}} = K_{V_0} \times \frac{1}{\sqrt{f}}$$

$$\Delta p_{Medium} = \Delta p_0 \times f$$

$$m_{Medium} = m_0 \times \frac{1}{\sqrt{f}}$$

Table 1. Values for correction factor f

Medium	water part	Correction factor f					
		5°C (41°F)	20°C (68°F)	35°C (95°F)	50°C (122°F)	65°C (149°F)	80°C (176°F)
Normal water	100%	1,000	0,998	0,994	0,988	0,981	0,972
Ethylen glycol	70%	1,052	1,047	1,041	1,033	1,024	1,015
e.g. Antifrogen N	50%	1,086	1,079	1,070	1,061	1,052	1,042
Propylen glycol	70%	1,035	1,029	1,021	1,012	1,002	0,991
e.g. Antifrogen L	50%	1,053	1,044	1,035	1,025	1,014	1,002

Honeywell

Control Products

Honeywell AG
Zu den Ruhrwiesen 3
D-59755 Arnsberg-Neheim

Phone: (49) 2932 9880
Fax: (49) 2932 988239
mng@honeywell.com

<http://europe.hbc.honeywell.com>