

MCV2000 SERIES

2-WAY HYDRONIC VALVES

PRODUCT SPECIFICATION SHEET



FEATURES

- Control by a low or line voltage SPST or SPDT controller
- 100~130 VAC or 200~240VAC actuators available
- Minimal actuator power consumption
- Pressure differential up to 3.5bar
- Versatile valve(1/2" ~ 1 1/4") selection
- 1~90 °C fluid temperature
- 0~65 °C ambient temperature

APPLICATION

The MCV2000 series are designed for residential hydronic heating and cooling control applications.

The MCV2000 series 2-position hydronic valves are used in residential and small commercial applications to control the flow of hot and/or cold water. They consist of actuator and valve.

Contents

Application	1
Features	1
Specification	1~3
Dimensions	3
Installation	4
Wiring Diagram	4

SPECIFICATION

Voltage	: AC110/220V±10%, 50/60Hz
Colour-coded label	: Blue, Black, Brown
Control Performance	: SPST/SPDT control
Power consumption	: 6W at nominal voltages (during valve position change only)
Operational life	: Greater than 60,000 cycles (all loads) for motor and valve contacts at 110/220V
Timing	: 7.5sec (20sec in case 1 1/4" valve)

Pipe connection	: PT
Maximum pressure	: 10bar max.
Electrical termination	: with integral 1000mm lead-wire cable
Ambient Temperature	: 0 ~ 65 °C
Ambient Humidity	: 10 ~ 95%RH (no condensing)
Storage temperature	: -25 ~ 65 °C
Storage Humidity	: 10 ~ 95%RH (no condensing)

Table 1. Model Selection Guide

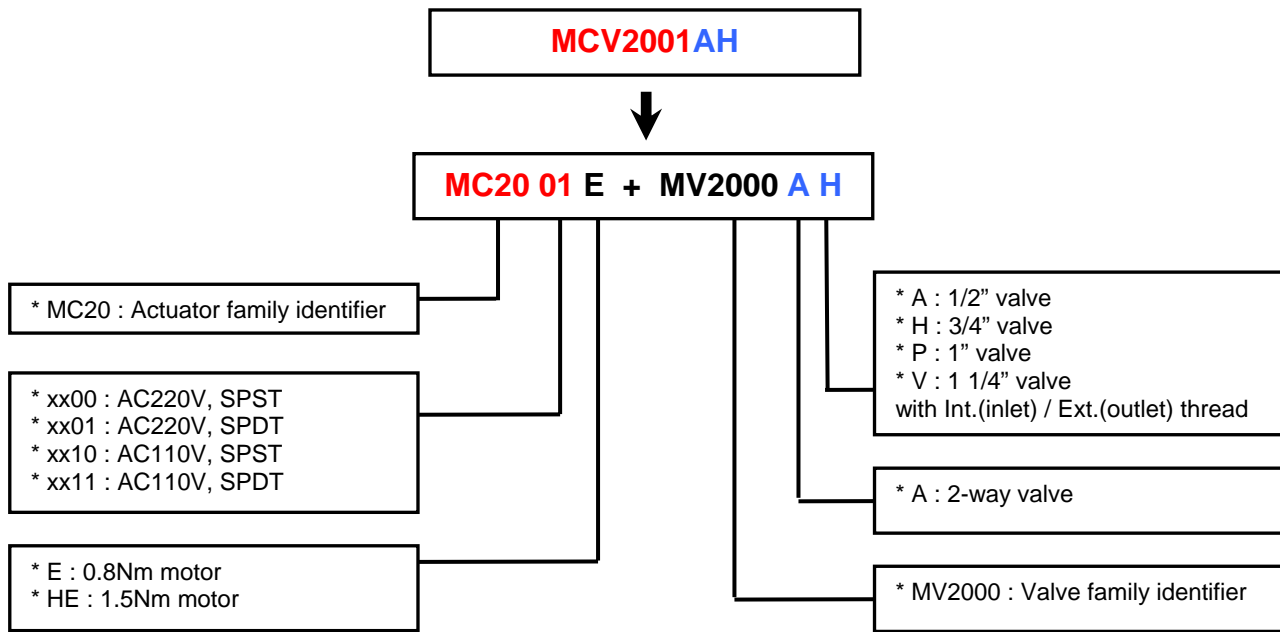

* MCV2001AH = MC2001E + MV2000AH : AC220V, SPDT, 0.8Nm, 3/4", 2-way valve
(with int.(inlet) / Ext.(outlet) thread & PT fitting)

Table 2. Model Assembly Guide

Model (Assembly)	Model(Motor)	Model(Valve)
MCV2000AA	MC2000E	MV2000AA
MCV2000AH		MV2000AH
MCV2000AP		MV2000AP
MCV2000AV	MC2000HE	MV2000AV
MCV2001AA	MC2001E	MV2000AA
MCV2001AH		MV2000AH
MCV2001AP		MV2000AP
MCV2001AV	MC2001HE	MV2000AV

Model (Assembly)	Model(Motor)	Model(Valve)
MCV2010AA	MC2010E	MV2000AA
MCV2010AH		MV2000AH
MCV2010AP		MV2000AP
MCV2010AV	MC2010HE	MV2000AV
MCV2011AA	MC2011E	MV2000AA
MCV2011AH		MV2000AH
MCV2011AP		MV2000AP
MCV2011AV	MC2011HE	MV2000AV

* Product Examples

- MC20xxE/HE : Actuator only, Egg crate with 15 actuators
- MV20xxAA/AH/AP/AV : Valve only, Egg crate with 40 valves(1/2"), 30 valves(3/4"), 21 valves(1"), 10 valves(1 1/4")

Table 3. Kv & Differential Pressure

Valve size	Kv	Max. operating differential pressure
1/2"	1.7	3.5 bar
3/4"	1.9	3.5 bar
1"	2.1	3.5 bar
1 1/4"	5.5	2.8 bar

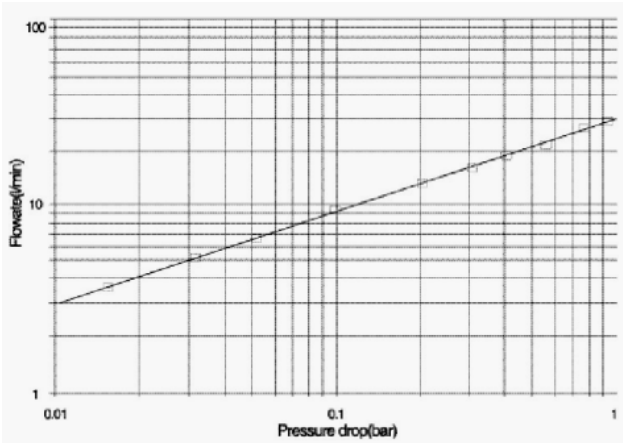

< 1/2" valve >

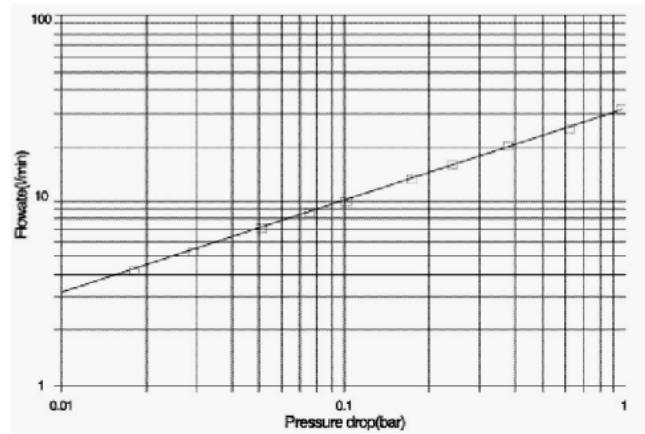

< 3/4" valve >

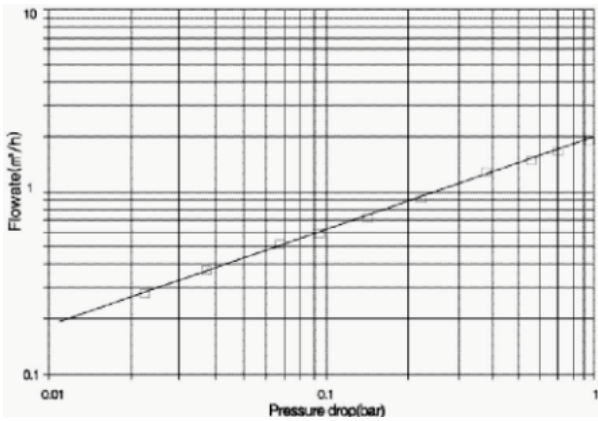

< 1" valve >

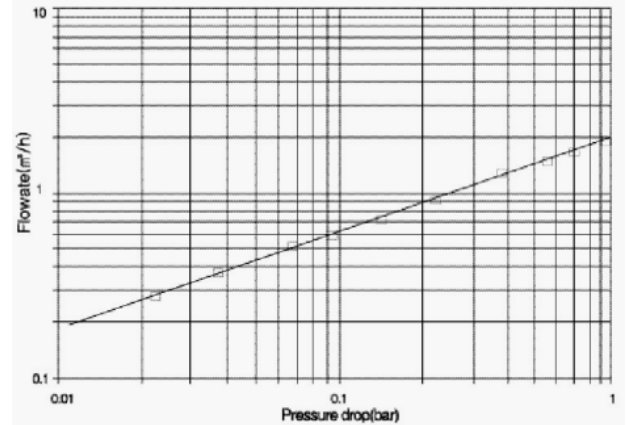

< 1 1/4" valve >

Fig. 1 Valve Pressure Loss Characteristic for 2-way Valves

DIMENSIONS

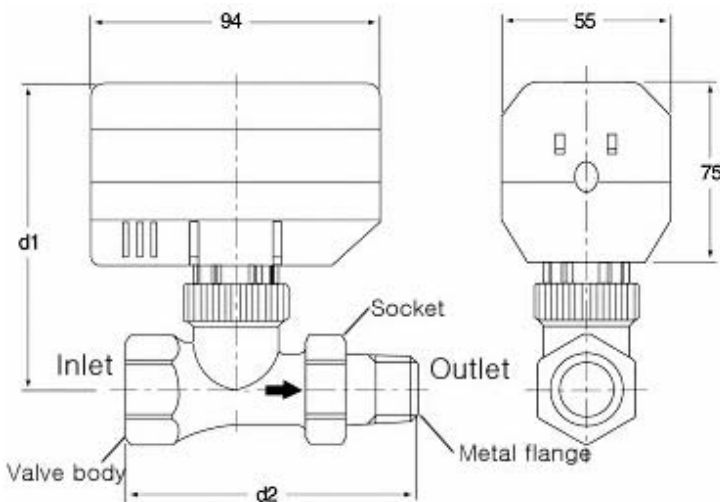

Valve Size	d2(mm)	d1(mm)
1/2"	95	100(in 1")
3/4"	106	
1"	125	
1 1/4"	150	

Fig. 2 MCV Valve Dimensions (in mm)

WARNING

- Take care that installer is a trained experienced service person.

When installing this product:

- Read these instructions carefully.
Failure to follow them could damage the product or cause a hazardous condition.
- Check the ratings given in the instructions and on the product to make sure it is suitable for your application.
- Always conduct a through checkout after installation.

CAUTION

- Disconnect Power Supply before making electrical connections to prevent electrical shock and equipment damage.

INSTALLATION

1. The valve may be plumbed in any angle but preferably not with the actuator head below the horizontal level of the valve body. Make sure there is enough room around the actuator head for servicing or replacement.
2. The valve body can be mounted directly onto the inlet pipe. Mount the metal flange inserted in socket to outlet pipe. And then tighten the socket enough to make a seal. See Figure 2 for the detail dimension.
3. Mount the valve directly in the tube or pipe. Do not grip actuator head while making and tightening plumbing connections. Either hold valve body in your hand or attach adjustable spanner across the hexagonal or flat faces on the valve body.

WIRING DIAGRAM

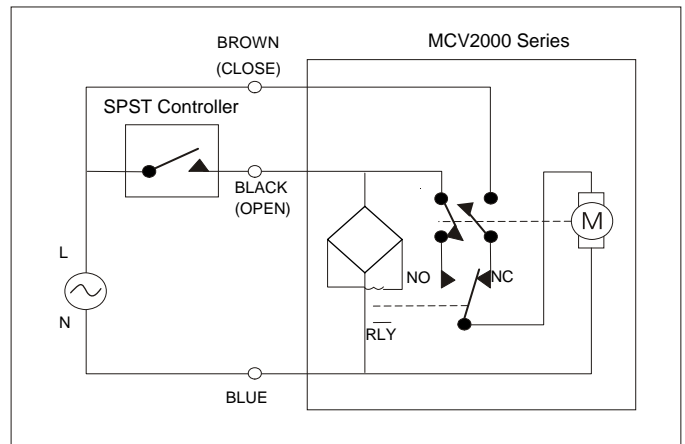

Fig. 3 Diagram with 3-wire Actuator for SPST Controller

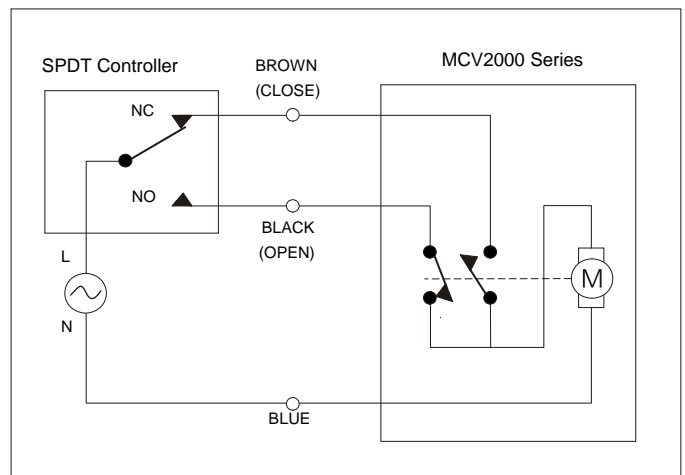

Fig. 4 Diagram with 3-wire Actuator for SPDT Controller

HONEYWELL

Honeywell Co., Ltd.

Environmental & Combustion Controls
 18F, Kukje Center Building 191, Hangangro-2ga,
 Yongsan-gu, Seoul, 140-702, Korea
 Tel. 82-2-799-6170/6194
 Fax. 82-2-792-9013