

# Rosemount 3300 Series Guided Wave Radar Level and Interface Transmitter

Rosemount 3300 Series comprises smart, loop-powered level and interface transmitters based on the guided wave radar technology. These instruments provide outstanding reliable measurements on liquids and slurries even for severe conditions, due to advanced signal processing with digital sampling and high signal to noise ratio.

- *First loop-powered level and interface transmitter. Multivariable™ output from one device reduces process penetrations and installation costs.*
- *Direct level measurement means no compensation for changes in temperature, pressure, density, dielectric or conductivity.*
- *Virtually unaffected by dust, vapor, interfering obstacles and turbulence. Even suitable for small or odd shaped tanks.*
- *Intrinsically safe and Explosion proof makes it suitable for hazardous areas.*
- *PC setup software with installation wizard provides easy configuration.*



- *Dual compartment transmitter housing (electronics and cabling separated) which can be removed without opening the tank, and cut-to-fit probes facilitate easy installation and minimize need for maintenance.*
- *Compatible with the Asset Management Solutions™ (AMS) plant management software - cuts costs by streamlining maintenance tasks.*

## Content

|   |               |
|---|---------------|
| Measurement Principle . . . . .                             | page Level-4  |
| Applications . . . . .                                      | page Level-4  |
| System Integration . . . . .                                | page Level-6  |
| Select Guided Wave Radar Transmitter . . . . .              | page Level-8  |
| Measuring Range . . . . .                                   | page Level-11 |
| Interface . . . . .   | page Level-12 |
| Replacing Displacer in an Existing Displacer Cage . . . . . | page Level-13 |
| Mechanical Considerations . . . . .                         | page Level-14 |
| Specifications . . . . .                                    | page Level-15 |
| Hazardous Locations Certifications . . . . .                | page Level-18 |
| Dimensional Drawings . . . . .                              | page Level-19 |
| Ordering Information . . . . .                              | page Level-25 |
| Application & Configuration Data Sheets . . . . .           | page Level-29 |

# Rosemount 3300 Series

## Measurement Principle

Rosemount 3300 Series is based on the TDR (Time Domain Reflectometry) technology.

Low power nano-second microwave pulses are guided down a probe immersed in the process media.

When a radar pulse reaches a media with different dielectric constant, part of the energy is reflected back to the transmitter and the time difference between the transmitted (reference) and the reflected pulse is converted into a distance from which the total level or interface level is calculated.

The intensity of the reflection depends on the dielectric constant of the product. The higher dielectric constant value, the stronger the reflection will be.

The transmitter uses Dynamic Gain Optimization™ which means it automatically adjusts gain to maximize signal-to-noise ratio in each application. This increases measurement reliability and capability.

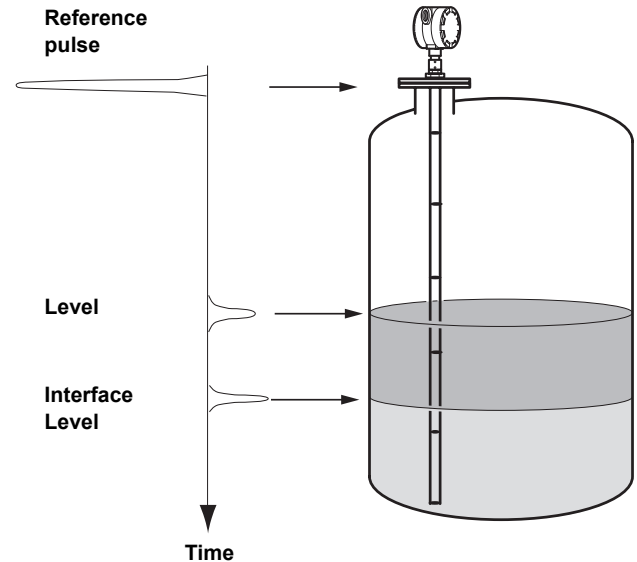

## Applications

Rosemount 3300 Series can be used for level measurements on most liquids, semi-liquids and liquid/liquid interfaces.

The 3300 Series consists of two models:

- Rosemount 3301, Guided Wave Radar Level Transmitter for liquids and some solids.
- Rosemount 3302, Multivariable™ Guided Wave Radar Level and Interface Transmitter for liquids.

Rosemount 3300 Guided Wave Radar transmitters offer high reliability and performance.

Measurements are virtually unaffected by temperature, pressure, vapor gas mixtures, density, turbulence, bubbling/boiling, varying dielectric media and viscosity.

Since the waves are guided along the probe this technology is excellent for small and narrow tanks / tank openings.

Rosemount 3300 Series is suitable for measurements in:

- Chemical and petrochemical industry.
- Oil and gas industry.
- Pulp and paper industry.
- Pharmaceutical plants.
- Food and beverage industry.
- Water and sewage treatment.
- Hydroelectric dams and power plants.

## APPLICATION EXAMPLES FOR GUIDED WAVE RADAR

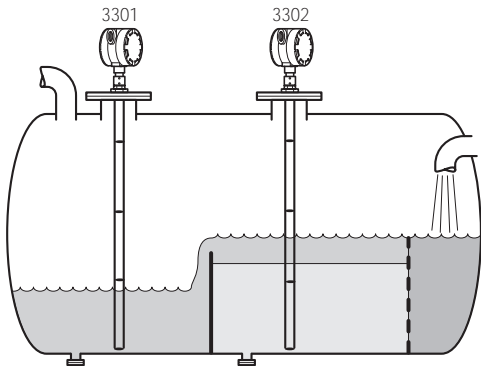

**Separator tank. Rosemount 3302 is the first two-wire radar transmitter for measuring both level and interface level.**

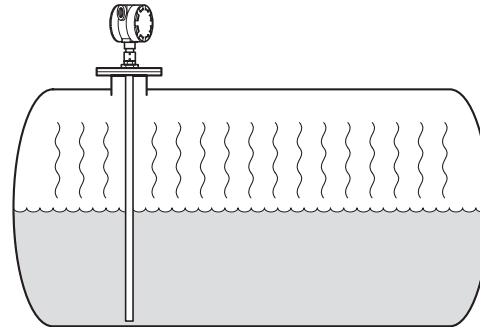

**Guided wave radar technology is a good choice for reliable measurements in small ammonia, NGL (Natural Gas Liquids) and LPG tanks.**

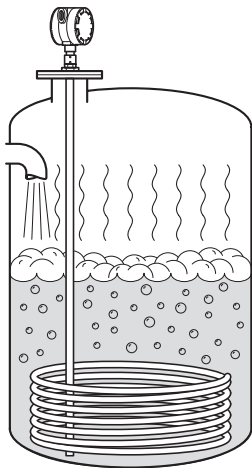

**Guided wave radar technology in combination with advanced signal processing make Rosemount 3300 Series transmitters the perfect solution for boiling conditions with vapor and turbulence.**

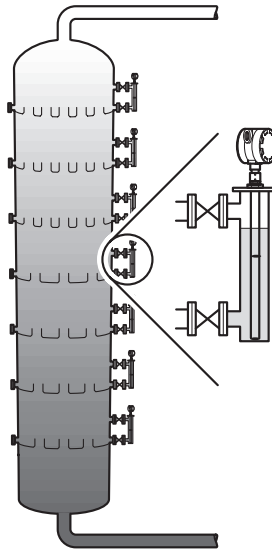

**Rosemount 3300 Series transmitters are well suited for bridge applications such as distillation columns.**

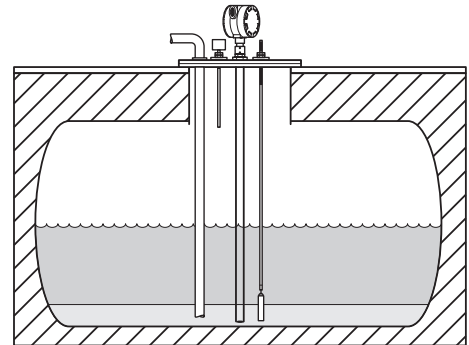

**Rosemount 3300 Series is a good choice for underground tanks, since it is installed on the tank top, with the radar pulse concentrated near the probe. It can be equipped with probes that are unaffected by high and narrow openings or nearby objects.**

# Rosemount 3300 Series

## System Integration

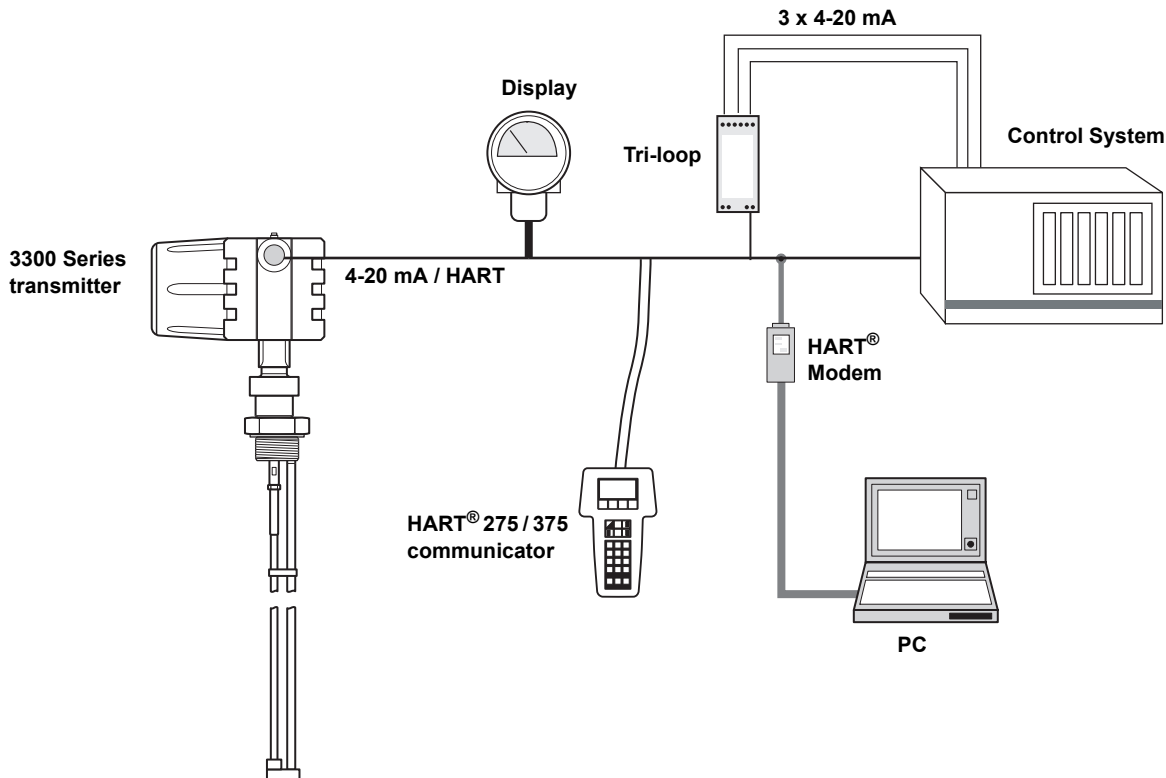

### INPUTS / OUTPUTS

The 3300 Series transmitter uses the same two wires for both power supply and output signal (loop-powered).

The input voltage is 11-42 VDC (11-30 VDC in IS applications, 16-42 VDC in Explosion Proof / Flame Proof applications).

Measurement data is transmitted as an analog 4-20 mA signal with a superimposed digital HART® signal. The HART® signal can be used in a multidrop mode.

By sending the digital HART® signal to the optional HART® Tri-loop, it is possible to have up to three additional 4-20 mA analog signals.

See Rosemount 333 HART® Tri-loop Product Data Sheet (document number 00813-0100-4754) for additional information.

The transmitter is available with Intrinsically Safe or Explosion Proof approvals. A safety isolator such as a zener barrier must be used for intrinsic safety. Refer to "Hazardous Locations Certifications" / "Ordering Information" .



The optional HART® Tri-loop, HART-to-Analog Signal Converter.

## Product Data Sheet

00813-0100-4811, Rev AC  
Catalog 2004

# Rosemount 3300 Series

## DISPLAY

Data can be read from the optional integral display or remote by using the 4-digit LCD display Rosemount 751 Field Signal Indicator (see document number 00813-0100-4378, Product Data Sheet for Rosemount 751).



The integral display is easily configured from Radar Configuration Tools or the HART® 275 or 375 Communicator. It displays measured values by toggling between chosen variables.

## MEASUREMENT PARAMETERS

From one Rosemount 3300 Series radar transmitter it is possible to receive multiple process variables. Details on parameters are given in the table below.

|                       | 3301 | 3302 |
|-----------------------|------|------|
| Level                 | X    | X    |
| Distance to Level     | X    | X    |
| Interface Level       | (X)* | X    |
| Interface Distance    | (X)* | X    |
| Upper Layer Thickness |      | X    |
| Total Volume          | X    | X    |

\* Interface measurement only for fully immersed probe, see page page Level-12.

## CONFIGURATION

Configuration can easily be done either with a HART® 275 or 375 communicator or a PC with the user-friendly, Windows based software package for setup - Radar Configuration Tools.

To communicate with the transmitter, a HART® modem is required and it is included in the delivery (see picture on page page Level-6). The HART® modem can also be ordered separately (part number 03300-7004-0001)

Rosemount 3300 Series transmitters are compatible with the AMS (Asset Management Solutions) software which also can be used for configuration.

For further information, visit [www.emersonprocess.com/AMS](http://www.emersonprocess.com/AMS).

By filling in the Configuration Data Sheet (CDS), it is possible to order a pre-configured transmitter.



Radar Configuration Tools with installation wizard and waveform plot possibilities provides easy configuration and service.



# Rosemount 3300 Series

## Select Guided Wave Radar Transmitter

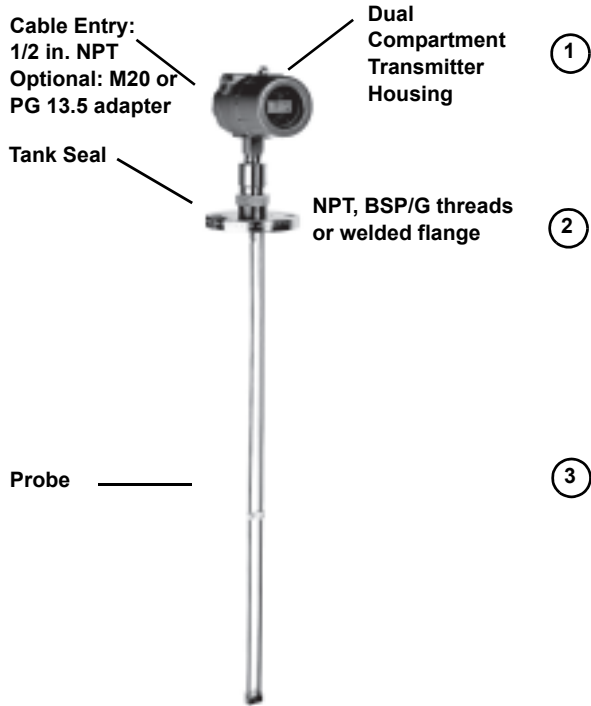

A Rosemount 3300 Series transmitter consists of transmitter housing, tank connection and probe.

Probe and tank seal are the only parts in contact with tank atmosphere.

The transmitter can be equipped with different probes to fulfill various application requirements.

### TRANSMITTER HOUSING ①

The transmitter is available in two models (see page page Level-4 and Level-7), 3301 and 3302 and it can be ordered with Intrinsically Safe or Explosion Proof / Flame Proof approvals (see page Level-6).

The dual compartment transmitter housing can be removed without opening the tank. It has electronics and cabling separated. The housing has two entries for conduit/cable connections.

The 3300 Series is available with 1/2 in. NPT cable entry, and M20 or PG 13.5 adapter as an option. See "Ordering Information".

### TANK CONNECTION ②

The tank connection consists of tank seal, a welded flange (EN (DIN), ANSI, Fisher or Masoneilan) or NPT or BSP/G threads (1 or 1.5 in. depending on probe type, see "Ordering Information").

Flange dimensions follow standard ANSI B 16.5 and EN 1092-1 type 05 (DIN 2527 type B) for blind flanges if the transmitter is ordered with a flange. For Fisher and Masoneilan flange dimensions, see "Flanges" on page Level-24.

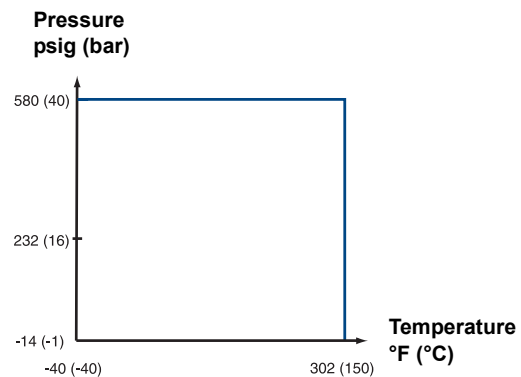

Process temperature and pressure diagram for Rosemount 3300 series transmitters. Final rating depends on flange and O-ring selection.

The following table gives the temperature ranges for tank seal with different O-ring material.

| Tank seal with different O-ring material | Min. Temperature °F (°C) in air | Max. Temperature °F (°C) in air |
|--|---------------------------------|---------------------------------|
| Viton                                    | 5 (-15)                         | 302 (150)                       |
| Ethylene Propylene (EPDM)                | -40 (-40)                       | 266 (130)                       |
| Kalrez 6375                              | 14 (-10)                        | 302 (150)                       |
| Buna-N                                   | -31 (-35)                       | 230 (110)                       |

## PROBES <sup>(3)</sup>

Several versions of probes are available: Coaxial, Rigid Twin and Rigid Single Lead, Flexible Twin and Flexible Single Lead.

Total probe length is defined from upper reference point to end of probe (weight included if applicable).

For guidance in probe selection, see table on page Level-10.

### Dead Zones

Dead zones are areas where measurements can't be made or will have reduced accuracy. See picture and table below.

If measurements are desired at the very top of the tank it is possible to mechanically extend the nozzle and use the coaxial probe. Then the upper dead zone is moved into the extension.

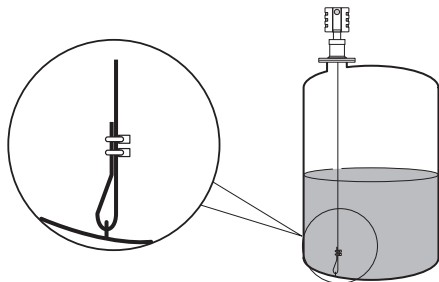
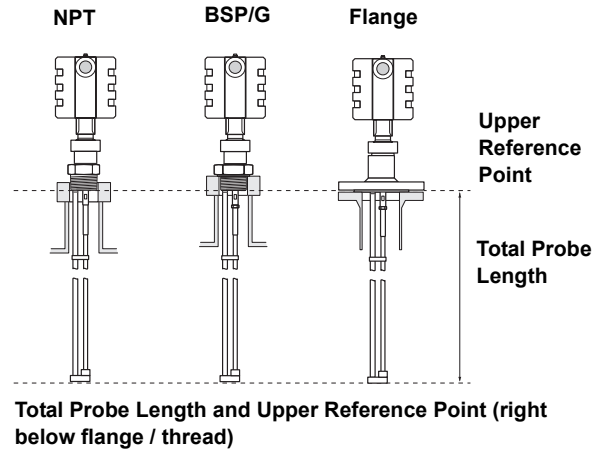

For a flexible single lead probe with chuck, the lower dead zone is measured upwards from the upper clamp.

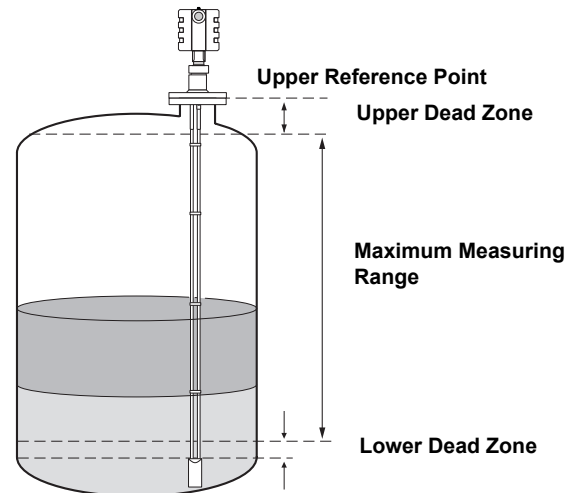

|                                      | Dielectric Constant | Coaxial Probe     | Rigid Twin Lead Probe | Flexible Twin Lead Probe                          | Rigid Single Lead Probe | Flexible Single Lead Probe                        |
|--------------------------------------|---------------------|-------------------|-----------------------|---|-------------------------|---|
| <b>Upper<sup>(1)</sup> Dead Zone</b> | 80                  | 4 in.<br>(10 cm)  | 4 in.<br>(10 cm)      | 5.9 in.<br>(15 cm)                                | 4 in.<br>(10 cm)        | 5.9 in.<br>(15 cm)                                |
|                                      | 2                   | 4 in.<br>(10 cm)  | 4 in.<br>(10 cm)      | 8 in.<br>(20 cm)                                  | 4 in.<br>(10 cm)        | 20 in.<br>(50 cm)                                 |
| <b>Lower<sup>(2)</sup> Dead Zone</b> | 80                  | 1.2 in.<br>(3 cm) | 2 in.<br>(5 cm)       | 2 in. <sup>(3)</sup><br>(5 cm <sup>(3)</sup> )    | 2 in.<br>(5 cm)         | 2 in. <sup>(3)</sup><br>(5 cm <sup>(3)</sup> )    |
|                                      | 2                   | 2 in.<br>(5 cm)   | 2.8 in.<br>(7 cm)     | 5.9 in. <sup>(3)</sup><br>(15 cm <sup>(3)</sup> ) | 4 in.<br>(10 cm)        | 4.7 in. <sup>(3)</sup><br>(12 cm <sup>(3)</sup> ) |

(1) The distance from the reference point where measurements should be avoided, see picture above.

(2) The distance from the probe end where measurements have reduced accuracy, see picture above.





(3) Note that the weight length adds to non-measurable area and is not included in the diagram. See "Dimensional Drawings".

### NOTE

The 4-20 mA set points should be configured between the dead zones, within the measuring range (see picture and diagram above).

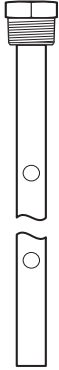
# Rosemount 3300 Series

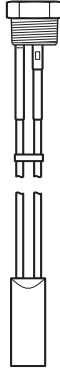
In the table below: G=Good, NR=Not Recommended, AP=Application Dependent (consult factory).

|   | Coaxial   | Rigid Twin Lead   | Flexible Twin Lead   | Rigid Single Lead   | Flexible Single Lead  |
|---|---|---|--|---|---|
| This table gives guidelines on which probe to select, depending on application.               |  |  |  |  |  |
| <b>Measurements</b>   |   |   |  |   |   |
| Level   | G   | G   | G  | G   | G   |
| Interface (liquid/liquid)   | G   | G   | G  | AP  | NR  |
| <b>Process Medium Characteristics</b>   |   |   |  |   |   |
| Changing density  | G   | G   | G  | G   | G   |
| Changing dielectric <sup>(1)</sup>  | G   | G   | G  | G   | G   |
| Wide pH variations  | G   | G   | G  | G   | G   |
| Pressure changes  | G   | G   | G  | G   | G   |
| Temperature changes   | G   | G   | G  | G   | G   |
| Condensing vapors   | G   | G   | G  | G   | G   |
| Bubbling / boiling surfaces   | G   | G   | AP   | G   | AP  |
| Foam (mechanical avoidance)   | AP  | NR  | NR   | NR  | NR  |
| Foam (top of foam measurement)  | NR  | AP  | AP   | AP  | AP  |
| Foam (foam and liquid measurement)  | NR  | AP  | AP   | NR  | NR  |
| Clean liquids   | G   | G   | G  | G   | G   |
| Liquid with dielectric < 2.5  | G   | AP  | AP   | NR  | NR  |
| Coating/sticky liquids  | NR  | NR  | NR   | AP  | AP  |
| Viscous liquids   | NR  | AP  | AP   | AP  | G   |
| Crystallizing liquids   | NR  | NR  | NR   | AP  | AP  |
| Fibrous liquids   | NR  | NR  | NR   | G   | G   |
| <b>Tank Environment Considerations</b>  |   |   |  |   |   |
| Probe will be close (< 12 in. / 30 cm) to tank wall / disturbing objects                      | G   | AP  | AP   | AP  | AP  |
| High turbulence   | G   | G   | AP   | G   | AP  |
| Turbulence conditions causing breaking forces   | NR  | NR  | AP   | NR  | AP  |
| Long and small mounting nozzles (diameter < 6 in. (15 cm), height > diameter + 4 in. (10 cm)) | G   | AP  | NR   | NR  | NR  |
| Probe might touch nozzle / disturbing object  | G   | NR  | NR   | NR  | NR  |
| Liquid or vapor spray might touch probe   | G   | NR  | NR   | NR  | NR  |
| Disturbing EMC environment in tank  | AP  | NR  | NR   | NR  | NR  |

(1) For overall level applications, a changing dielectric has no effect on the measurement. For interface measurements, a changing dielectric of the top fluid will degrade the accuracy of the interface measurement.

## Measuring Range

In the table below, measuring range information is given for each probe. Since measuring range depends on the application and on the different factors described in this chapter, the values are given as a guideline for clean liquids. For more information, consult factory.

| Coaxial                            | Rigid Twin Lead   | Flexible Twin Lead   | Rigid Single Lead   | Flexible Single Lead   |
|------------------------------------|-------------------|--|---|--|
| <b>Maximum Measuring Range</b>     |                   |  |   |  |
| 19 ft 8 in. (6 m)                  | 9 ft 10 in. (3 m) | 77 ft 1 in. (23.5 m)   | 9 ft 10 in. (3 m)   | 77 ft 1 in. (23.5 m)   |
| <b>Minimum Dielectric Constant</b> |                   |  |   |  |
| 1.6                                | 1.9               | 1.6 up to 33 ft (10 m)<br>2.0 up to 66 ft (20 m)<br>2.4 up to 77 ft 1 in. (23.5 m) | 2.5<br>(1.9 if installed in a metallic bypass or stilling well) | 2.5 up to 36 ft (11 m)<br>5.0 up to 66 ft (20 m)<br>7.5 up to 77 ft 1 in. (23.5 m) |

Different parameters affect the echo and therefore the maximum measuring range differs depending on application according to:

- Disturbing objects close to the probe.
- Media with higher dielectric constant ( $\epsilon_r$ ) gives better reflection and allows a longer measuring range.
- A calm surface gives better reflection than a turbulent surface. For a turbulent surface the measuring range might be reduced.
- Surface foam and particles in tank atmosphere are also circumstances that might affect measuring performance.
- Heavy coating /contamination on the probe should be avoided since it can reduce measuring range and might cause erroneous level readings.

### Coating

- Single lead probes are preferred when there is a risk for contamination (because coating can result in product bridging; across the two leads for twin versions, between the inner lead and outer pipe for the coaxial probe).
- For viscous or sticky applications, it is important to choose a suitable probe. Periodic cleaning might be required.
- Maximum error due to coating is 1-10% depending on probe type, dielectric constant, coating thickness and coating height above product surface.

| Coaxial                   | Twin Lead                             | Single Lead            |
|---------------------------|---------------------------------------|------------------------|
| <b>Maximum Viscosity</b>  |                                       |                        |
| 500 cP                    | 1500 cP                               | 8000 cP <sup>(1)</sup> |
| <b>Coating / Build-up</b> |                                       |                        |
| Coating not recommended   | Thin coating allowed, but no bridging | Coating allowed        |

(1) Consult factory if agitation / turbulence and high viscosity.

# Rosemount 3300 Series

## Interface

Rosemount 3302 is the ideal choice for measuring the interface of oil and water, or other liquids with significant dielectric differences. It is also possible to measure interface with the Rosemount 3301 in bridle/tank applications when the probe is fully immersed in the liquid.

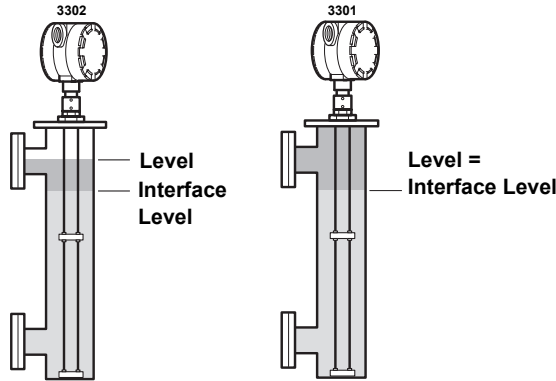

Interface Measurement with Rosemount 3302 and 3301 (fully immersed probe).

Coaxial, Rigid twin, Flexible twin and Rigid Single lead probes can be used for measuring interfaces. However, the coaxial probe is the preferred choice.

For measuring the interface level, the transmitter uses the residual wave of the first reflection. Part of the wave, which was not reflected at the upper product surface, continues until it is reflected at the lower product surface. The speed of this wave depends fully on the dielectric constant of the upper product.

If interface is to be measured, follow the criteria listed:

- The dielectric constant of the upper product must be known and should not vary. The Radar Configuration Tools software has a built-in dielectric constant calculator to assist the user in determining the dielectric constant of the upper product.
- The dielectric constant of the upper product must have a lower dielectric constant than the lower product in order to have a distinct reflection.
- The difference between the dielectric constants for the two products must be larger than 10.
- Maximum dielectric constant for the upper product is 10 for the coaxial probe and 5 for twin lead probes.
- The upper product thickness must be larger than 8 in. (0.2 m) for the flexible twin lead probe and 4 in. (0.1 m) for the rigid twin lead and coaxial probes in order to distinguish the echoes of the two liquids.

The maximum allowable upper product thickness / measuring range is primarily determined by the dielectric constants of the two liquids.

Target applications include interfaces between oil / oil-like and water / water-like liquids with low (<3) upper product dielectric constant and high (>20) lower product dielectric constant.

For such applications, maximum measuring range is only limited by the length of the coaxial, rigid twin and rigid single<sup>(1)</sup> lead probes.

For the flexible twin lead probe, maximum measuring range will be reduced depending on maximum upper product thickness according to the diagram below. However, characteristics vary widely between different applications. For other product combinations, consult factory.

Maximum Measuring Range, Flexible Twin Lead Probe, ft (m)

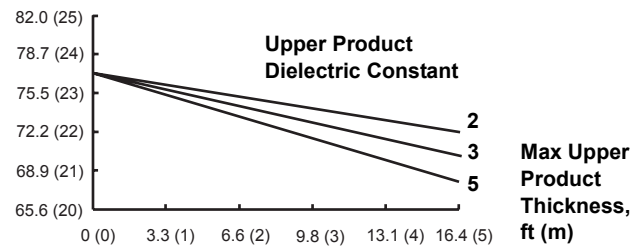

Example:  
If the upper product dielectric is 2 and maximum upper product thickness is 9.8 ft (3 m), maximum measuring range will be 74.1 ft (22.6 m).

### Emulsion Layer

Sometimes there is an emulsion layer (mix of the products) between the two products which, depending on its characteristics, will affect interface measurements.

For guidelines on emulsion situations, consult factory.

<sup>(1)</sup> Be aware of the minimum upper product dielectric constant for the rigid single lead probe, see page Level-11.

## Replacing Displacer in an Existing Displacer Cage

Rosemount 3300 Series transmitter is a perfect replacement in an existing displacer cage. Proprietary flanges are offered so existing cages can be used, which makes installation easy.

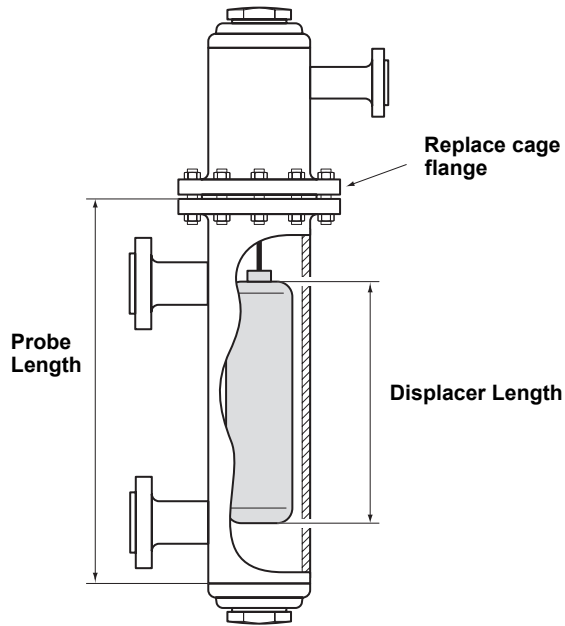

### 3300 Benefits

- No moving parts: Less need for maintenance - costs dramatically reduced, and as a result, also improved measurement availability.
- Reliable measurement, independent of density, turbulence, and vibrations.

### Considerations when changing to 3300

When changing from a displacer to a Rosemount 3300 Series transmitter, make sure to correctly match the 3300 series flange choice and probe length to the cage. Both standard ANSI and EN (DIN) as well as proprietary cage flanges with a non-standard diameter and gasket surface are used. See "Dimensional Drawings" on page Level-24 to help determine what flange is used.

The following table gives guidelines on required probe length.

| Cage Manufacturer  | Probe Length  |
|--------------------|---|
| Fisher 249B&C/259B | Displacer + 9 in. (23 cm)                                     |
| Masonellan         | Displacer + 8 in. (20 cm)                                     |
| Others             | Displacer + 8 in. (20 cm), approximate value, length can vary |

For other cages, consult factory.

# Rosemount 3300 Series

## Mechanical Considerations

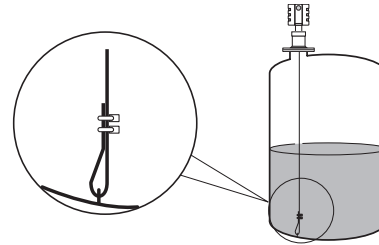
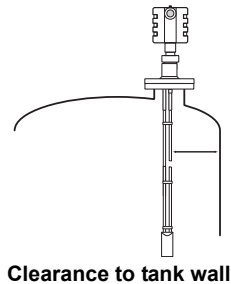
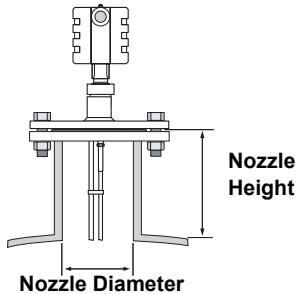

Flexible single lead probe with chuck. See the Reference Manual for more anchoring options.

Typically the transmitter is top mounted with flanged or threaded tank connection, but the probe can also be installed at an angle of up to 90° from vertical. It is also possible to turn the transmitter housing in any direction.

The probe must be hung, fully extended, through the entire distance where level readings are desired.

To get best possible performance, the following must be considered before installing the transmitter:

- Filling inlets creating turbulence should be kept at a distance.
- Max. recommended nozzle height is 4 in. (10 cm) + nozzle diameter.
- Avoid physical contact between probes and agitators as well as applications with strong fluid movement unless the probe is anchored. If the probe can move to within 1 ft (30 cm) of any object during operation then probe tie-down is recommended.
- In order to stabilize the probe for side forces, it is possible to fix or guide the probe to the tank bottom.

- Select probe length according to the required measuring range. The probe can be cut in field. However, there are some restrictions for the coaxial probe: Probes over 4.1 ft (1.25 m) can be cut up to 2 ft (0.6 m). Shorter probes can be cut to the minimum length of 1.3 ft (0.4 m).
- For optimal single lead probe performance in non-metallic vessels, the probe must either be mounted with a 2-inch / DN 50 or larger metallic flange, or a metal sheet with an 8-inch-diameter (200 mm) or larger must be used (see the Reference Manual for placement).

If there is a chance the probe comes into contact with a wall, nozzle or other tank obstruction the coaxial probe is the only possible choice. Minimum clearance is given in the table below.

For more information on mechanical installation, see the Reference Manual (document number 00809-0100-4811).

|  | Coaxial                       | Rigid Twin Lead             | Flexible Twin Lead    | Rigid Single Lead   | Flexible Single Lead  |
|--|-------------------------------|-----------------------------|-----------------------|---|---|
| <b>Recommended nozzle diameter</b>                               | Enough space to fit the probe | 4 in. (10 cm) or more       | 4 in. (10 cm) or more | 6 in. (15 cm) or more   | 6 in. (15 cm) or more   |
| <b>Min. nozzle diameter <sup>(1)</sup></b>                       | Enough space to fit the probe | 2 in. (5 cm)                | 2 in. (5 cm)          | 2 in. (5 cm)  | 2 in. (5 cm)  |
| <b>Min. clearance to tank wall or obstruction <sup>(2)</sup></b> | 0 in. (0 cm)                  | 4 in. (10 cm)               | 4 in. (10 cm)         | 4 in. (10 cm) if smooth metallic wall.<br>12 in. (30 cm) if disturbing objects, rugged metallic or concrete/plastic wall. | 4 in. (10 cm) if smooth metallic wall.<br>12 in. (30 cm) if disturbing objects, rugged metallic or concrete/plastic wall. |
| <b>Min. pipe / bypass diameter</b>                               | 1.5 in. (3.8 cm)              | 2 in. (5 cm) <sup>(3)</sup> | Consult factory       | 2 in. (5 cm) <sup>(4)</sup>   | Consult factory   |

(1) Requires special configuration and setting of Upper Null Zone. See "Application & Configuration Data Sheets" on page 29, Level-31 and Level-33.  
 (2) Minimum clearance from tank bottom for the coaxial and rigid single probes is 0.2 in. (5 mm).  
 (3) The centermost lead must be at least 0.6 in. (15 mm) away from the pipe/bypass wall.  
 (4) The probe must be centered in the pipe/bypass.

## Specifications

| <b>General</b>                        |  |
|---------------------------------------|--|
| Product                               | Rosemount 3300 Series Guided Wave Radar Level and Interface Transmitter;<br>Rosemount 3301 Level Transmitter (interface available for fully immersed probe).<br>Rosemount 3302 Level and Interface Transmitter.  |
| Measurement Principle                 | Time Domain Reflectometry (TDR).   |
| Reference Conditions                  | Twin lead probe, 77°F (25°C) water.  |
| Microwave Output Power                | Nominal 50 µW, Max. 2.0 mW.  |
| CE-mark                               | Complies with applicable directives (R&TTE, EMC, ATEX).  |
| Start-up Time                         | < 10 s   |
| <b>Display / Configuration</b>        |  |
| Integral Display                      | The integral digital display can toggle between: level, distance, volume, internal temperature, interface distance, interface level, peak amplitudes, interface thickness, percentage of range, analog current out.<br>Note! The display cannot be used for configuration purposes.  |
| Output Units                          | For Level, Interface and Distance: ft, inch, m, cm or mm.<br>For Volume: ft <sup>3</sup> , inch <sup>3</sup> , US gals, Imp gals, barrels, yd <sup>3</sup> , m <sup>3</sup> or liters.   |
| Output Variables                      | Rosemount 3301: Level, Distance to Level, Volume or for the case with fully immersed probe Interface Level and Interface Distance.<br>Rosemount 3302: Level, Distance to Level, Volume, Interface Level, Interface Distance and Upper Product Thickness.   |
| HART® Device for Remote Configuration | Rosemount hand-held communicator 275 or 375.   |
| PC for Remote Configuration           | Radar Configuration Tools software package.<br>Rosemount AMS Software.   |
| Damping                               | 0-60 s (10 s, default value)   |
| <b>Electric</b>                       |  |
| Power Supply                          | Loop-powered (2-wire), 11 - 42 VDC (11-30 VDC in IS applications, 16-42 VDC in Explosion Proof / Flame Proof applications).  |
| Output                                | Analog 4-20 mA, HART®.   |
| Signal on Alarm                       | Standard : Low = 3.75 mA, High = 21.75 mA.<br>Namur NE 43: Low = 3.60 mA, High = 22.50 mA.   |
| Saturation Levels                     | Standard: Low = 3.9 mA, High = 20.8 mA.<br>Namur NE 43: Low = 3.8 mA, High = 20.5 mA.  |
| IS Parameters                         | U <sub>i</sub> = 30 V, I <sub>i</sub> = 130 mA, P <sub>i</sub> = 1 W, L <sub>i</sub> =0, C <sub>i</sub> =0.  |
| Cable Entry                           | ½ - 14 NPT for cable glands or conduit entries.<br>Optional: M20 x 1.5 conduit / cable adapter or PG 13.5 conduit / cable adapter.   |
| Output Cabling                        | Twisted shielded pairs, 18-12 AWG.   |
| <b>Mechanical</b>                     |  |
| Probes                                | Coaxial: 1.3 ft (0.4 m) to 19.7 ft (6 m).<br>Rigid Twin Lead: 1.3 ft (0.4 m) to 9.8 ft (3 m).<br>Flexible Twin Lead: 3.3 ft (1 m) to 77.1 ft (23.5 m).<br>Rigid Single Lead: 1.3 ft (0.4 m) to 9.8 ft (3 m).<br>Flexible Single Lead: 3.3 ft (1 m) to 77.1 ft (23.5 m).<br>For further information, see Probe Table on page Level-10 and "Ordering Information" on page Level-25". |
| Tensile Strength                      | Flexible Single Lead, Ø= 0.16 in. (4 mm): 2698 lb (12 kN)<br>Flexible Twin Lead: 2023 lb (9 kN)  |
| Collapse Load                         | Flexible Single Lead, Ø= 0.16 in. (4 mm): 3597 lb (16 kN)  |
| Sideway Capacity                      | Coaxial: 73.7 ft lbf or 3.7 lb at 19.7 ft (100 Nm or 1.67 kg at 6 m)<br>Rigid Twin Lead: 2.2 ft lbf or 0.22 lb at 9.8 ft (3 Nm or 0.1 kg at 3 m)<br>Rigid Single Lead: 4.4 ft lbf or 0.44 lb at 9.8 ft (6 Nm or 0.2 kg at 3 m)   |
| Material Exposed to Tank Atmosphere   | 316 / 316L SST (EN 1.4404), Teflon (PTFE, PFA) and O-ring materials (see "Ordering Information" on page Level-25).   |

# Rosemount 3300 Series

| <b>Mechanical, continued</b>       |  |
|------------------------------------|--|
| Dimensions                         | See "Dimensional Drawings" on page Level-19.   |
| Probe Angle                        | 0 to 90 degrees.   |
| Housing / Enclosure                | Polyurethane-covered Aluminum.   |
| Flanges, Threads                   | See "Tank Connection" on page Level-8 and "Ordering Information" on page Level-25.   |
| Height Above Flange                | See "Dimensional Drawings" on page Level-19.   |
| <b>Environment</b>                 |  |
| Ambient Temperature                | -40°F to +185°F ( -40°C to +85°C). For the LCD display, the temperature range is -4°F to +185°F (-20°C to +85°C).  |
| Storage Temperature                | -40°F to +176°F ( -40°C to +80°C )   |
| Process Temperature <sup>(1)</sup> | -40°F to +302°F ( -40°C to +150°C )  |
| Process Pressure <sup>(1)</sup>    | Full vacuum to 580 psig ( -1 to 40 Bar ).  |
| Humidity                           | 0 - 100% Relative Humidity.  |
| Ingress Protection                 | NEMA 4X, IP 66.  |
| Telecommunication (FCC and R&TTE)  | FCC part 15 (1998) subpart B and R&TTE (EU directive 97/23/EC). Considered to be an unintentional radiator under the Part 15 rules.  |
| Factory Sealed                     | Yes.   |
| Vibration Resistance               | DIN EN 60068-2-64, IEC 68-2-64, ANSI/ISA-571.03 SA1, VC2.  |
| Electromagnetic Compatibility      | Emission and Immunity: Meets EN 61326-1 (1997) and amendment A1, class A equipment intended for use in industrial locations if installed in metallic vessels or still-pipes.<br>When rigid / flexible single and twin lead probes are installed in non-metallic or open vessels, influence of strong electromagnetic fields might affect measurements. |
| Built-in Lightning Protection      | Meets EN 61000-4-4 Severity Level 4 and EN 61000-4-5 Severity Level 4.   |
| Pressure Equipment Directive (PED) | Complies with 97/23/EC article 3.3 (confirmed by DNV).   |
| Ordinary Location FM 3810          | Compliance.  |
| Boiler Approval CSA B51-97         | Compliance.  |
| <b>Measuring Performance</b>       |  |
| Reference Accuracy                 | ± 0.2 inch (5 mm) for probes ≤ 16.4 ft (5 m).<br>± 0.1% of measured distance for probes > 16.4 ft (5 m).   |
| Repeatability                      | ± 0.04 inch (1 mm).  |
| Ambient Temperature Effect         | Less than 0.01% of measured distance per °C.   |
| Update Interval                    | 1 per second.  |
| Measuring Range                    | 4 in. (0.1 m) to 77 ft 1 in. (23.5 m). Also see page page Level-9, Level-11 and page Level-15.   |

*(1) Final rating depends on flange and O-ring selection, See "Tank Connection" on page 8.*

**LOAD LIMITATIONS**

The HART® Communicator requires a minimum load resistance of 250 Ohm within the loop in order to function properly. The maximum load resistance can be determined from these diagrams.

**Non-Intrinsically Safe Installations**

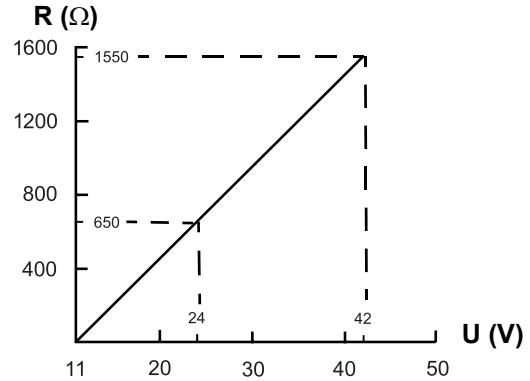

**Explosion Proof/Flame Proof Installations (Ex d)**

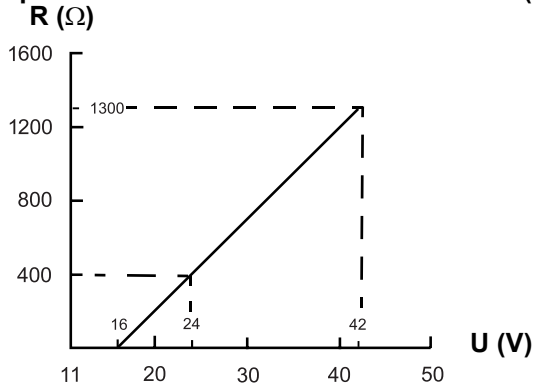

**Intrinsically Safe Installations**

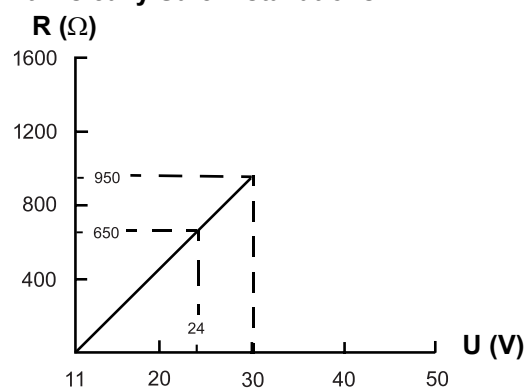

**NOTE**

For the Ex d case the diagram is only valid if the HART load resistance is at the + side, otherwise the load resistance value is limited to 300 Ohm.

# Rosemount 3300 Series



## Hazardous Locations Certifications

### Factory Mutual (FM) Approval

Project ID: 3013394

- E5 Explosion Proof for use in Class I, Div. 1, Groups B, C and D;  
Dust Ignition Proof for use in Class II/III, Div. 1, Groups E, F and G;  
With Intrinsically Safe connections to Class I, II, III, Div. 1, Groups A, B, C, D, E, F and G.  
Temperature Class T5 @ +85°C.  
Ambient temperature limits -40°C to +85°C.  
Factory Sealed.
- I5 Intrinsically Safe for Class I, II, III, Div. 1, Groups A, B, C, D, E, F and G,  
Class I, Zone 0, AEx ia IIC T4  $T_a=70^\circ\text{C}$ .  
Temp code T4 at 70°C max ambient.  
Control Drawing: 9150077-944.  
Non-Incendive Class I, Div. 2, Groups A, B, C and D;  
Suitable for Class II, III, Div. 2, Groups F and G.  
Non-incendive maximum operating parameters: 42 V, 25 mA.  
Temp code T4A at 70°C max ambient.

### ATEX Approval

- E1 Flame Proof:  
 II 1/2 GD T80°C.  
EEx d [ia] IIC T6 (-40°C <  $T_a$  < +75°C).  
KEMA 01ATEX2220.
- I1 Intrinsic Safety:  
 II 1 G EEx ia IIC T4 (-50°C <  $T_a$  < +70°C).  
BAS02ATEX1163X  
 $U_i=30$  VDC,  $I_i=130$  mA,  $P_i=1.0$  W,  $L_i=C_i=0$ .

### Canadian Standards Association (CSA) Approval

Cert. no 2002.1250250.

- E6 Explosion Proof: Class I, Div. 1, Groups C and D.  
Dust Ignition Proof:  
Class II, Div. 1 and 2, Groups G and coal dust.  
Class III, Div. 1, Haz. Loc.  
[Ex ia IIC T6].  
Ambient temperature limits -40°C to +85°C.  
Factory Sealed.
- I6 Intrinsically Safe: Ex ia IIC T4,  
Class I, Div. 1, Groups A, B, C and D.  
Temp code T4.  
Control Drawing: 9150077-945.  
Non-Incendive: Class III, Div. 1, Haz. Loc.  
Class I, Div 2, Groups A, B, C and D.  
Ambient temperature limits -40°C to +70°C.

For information on hazardous locations installations, refer to the Reference Manual.

### NOTE

A safety isolator such as a zener barrier is always needed for intrinsic safety.

# Dimensional Drawings

## COAXIAL

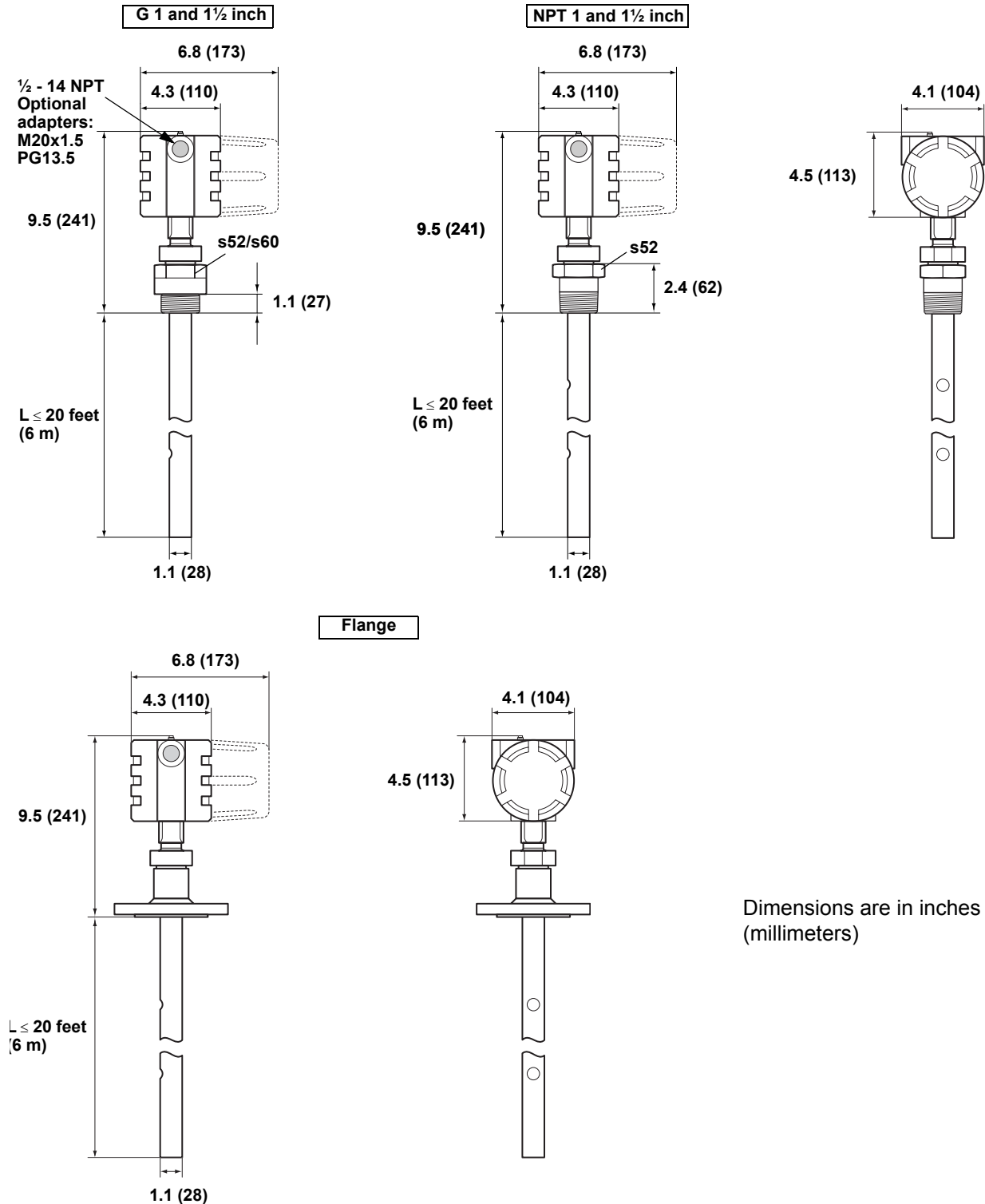

Dimensions are in inches  
(millimeters)

# Rosemount 3300 Series

## RIGID TWIN LEAD

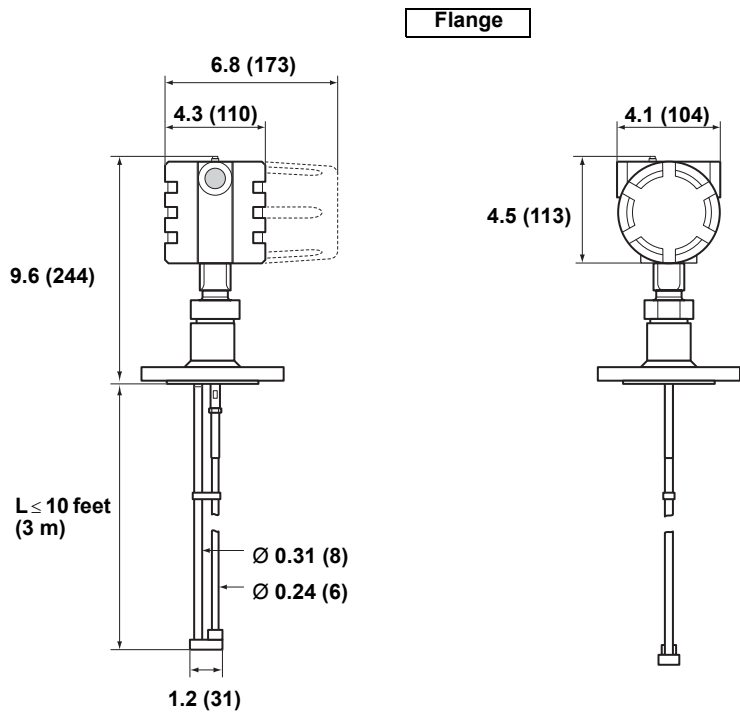
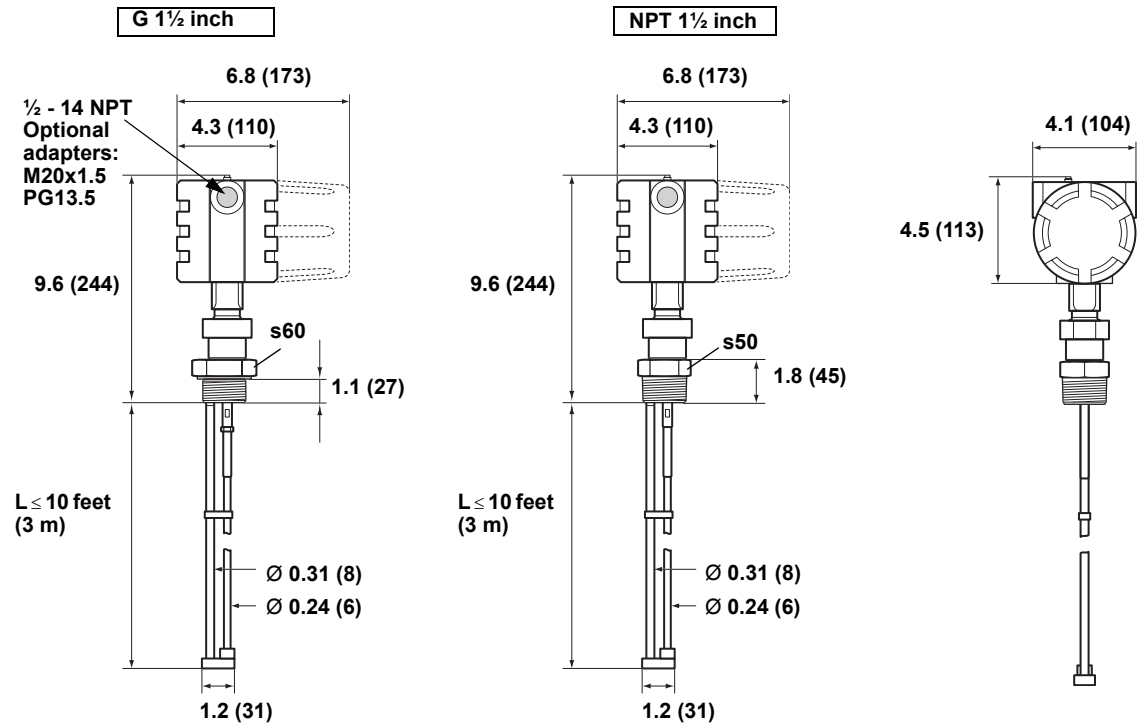

Centre-to-centre distance between probes is 0.75 in. (19 mm)

Dimensions are in inches (millimeters)

**FLEXIBLE TWIN LEAD**

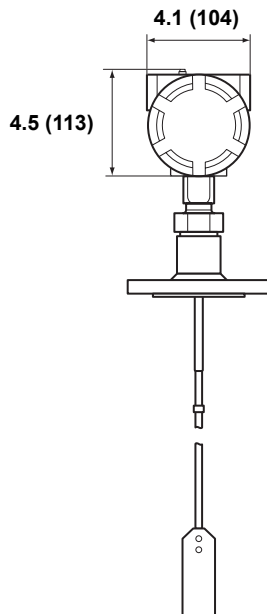
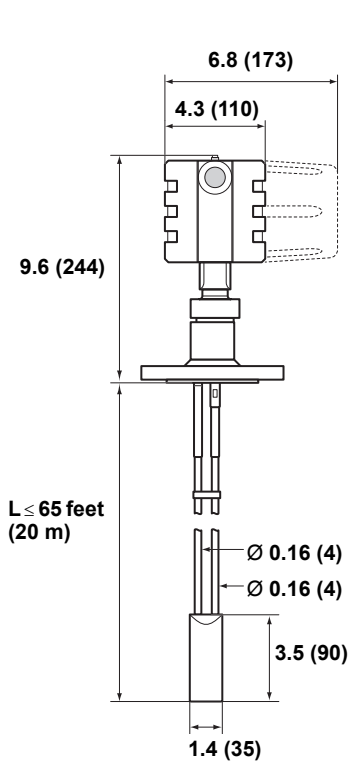
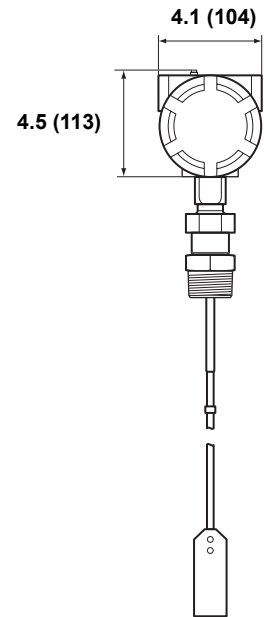
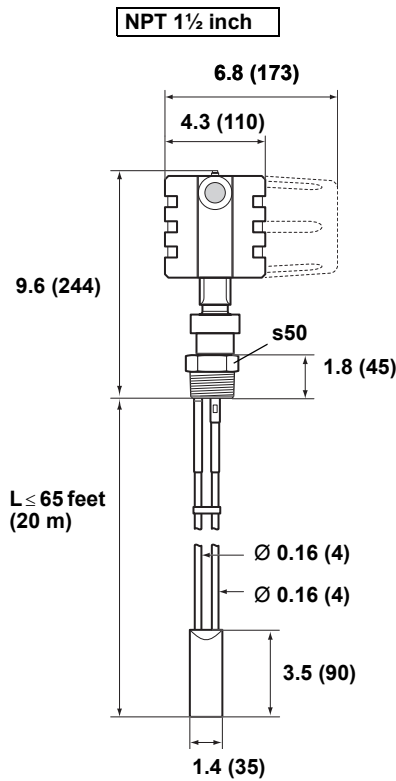
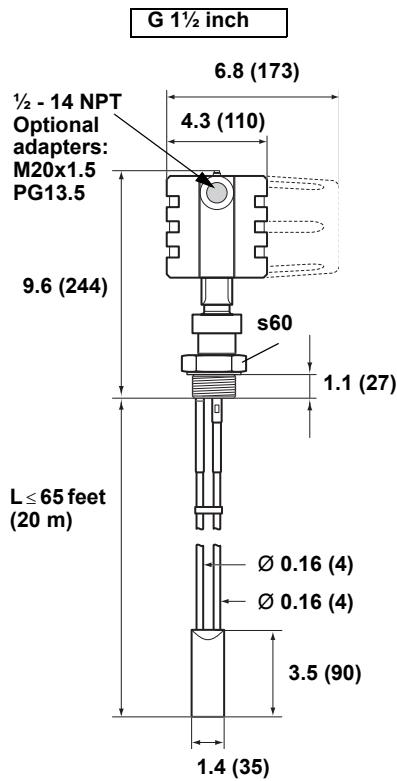

Centre-to-centre distance between probes is 0.67 in. (17 mm)

Dimensions are in inches (millimeters)

# Rosemount 3300 Series

## RIGID SINGLE LEAD

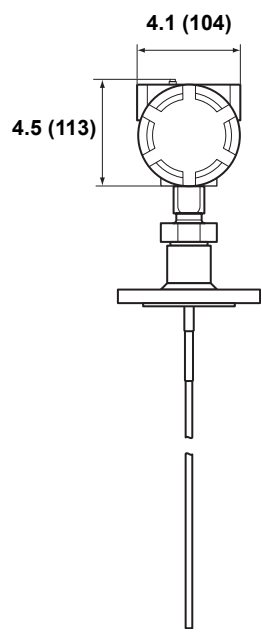
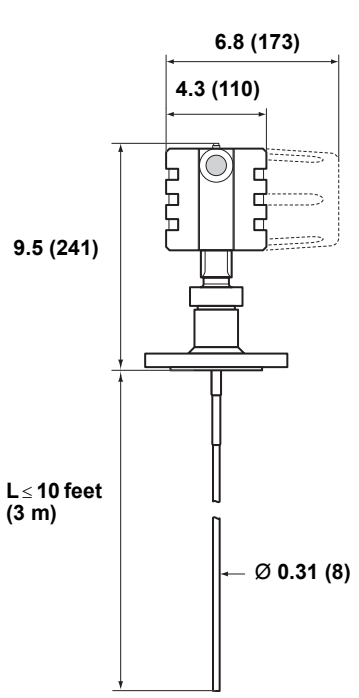
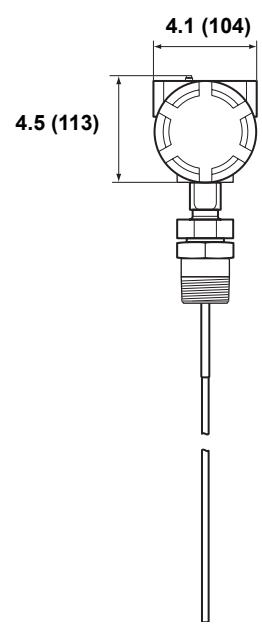
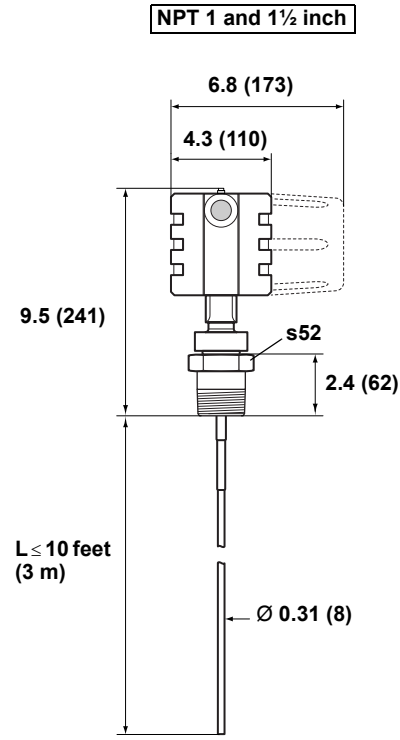
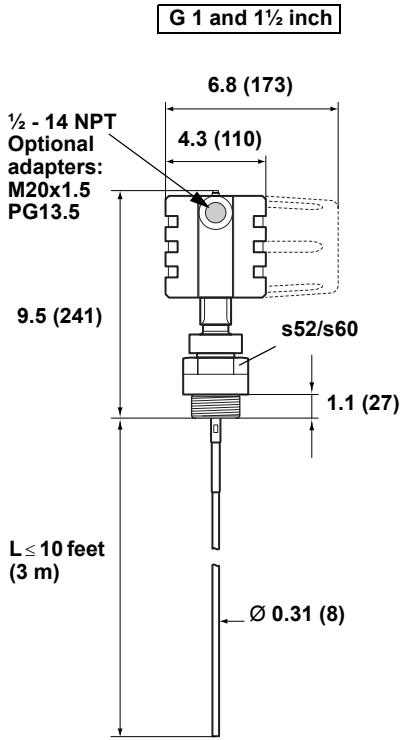

Dimensions are in inches  
(millimeters)

**FLEXIBLE SINGLE LEAD**

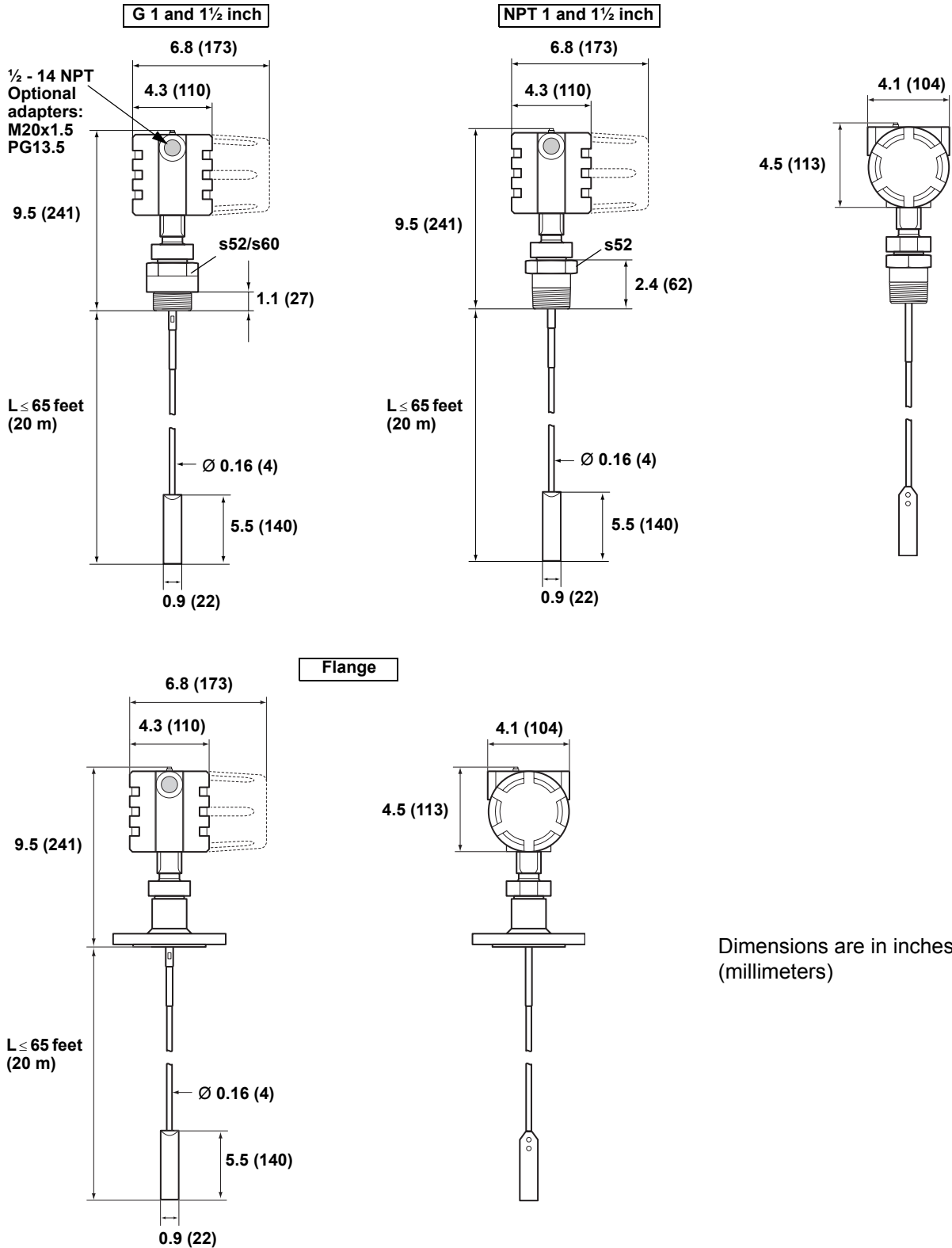

Dimensions are in inches  
(millimeters)

# Rosemount 3300 Series

## FLANGES

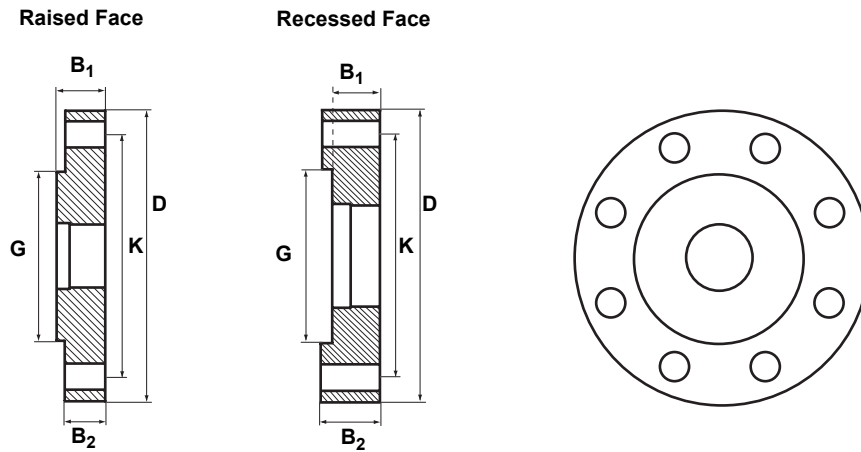

Dimensions are in inches (millimeters)

D: Outside diameter  
B1: Flange thickness with gasket surface  
B2: Flange thickness without gasket surface  
F=B1-B2: Gasket surface thickness  
G: Gasket surface diameter  
K: Bolt hole circle diameter

| Flange                              | D             | B <sub>1</sub> | B <sub>2</sub> | F            | G            | Number of bolts | K             |
|-------------------------------------|---------------|----------------|----------------|--------------|--------------|-----------------|---------------|
| <b>Proprietary Flanges</b>          |               |                |                |              |              |                 |               |
| Fisher 249B/259B                    | 9.00 (228.6)  | 1.50 (38.2)    | 1.25 (31.8)    | 0.25 (6.4)   | 5.23 (132.8) | 8               | 7.25 (184.2)  |
| Fisher 249C <sup>(1)</sup>          | 5.69 (144.5)  | 0.94 (23.8)    | 1.13 (28.6)    | -0.19 (-4.8) | 3.37 (85.7)  | 8               | 4.75 (120.65) |
| Masonellan                          | 7.51 (191.0)  | 1.54 (39.0)    | 1.30 (33.0)    | 0.24 (6.0)   | 4.02 (102.0) | 8               | 5.87 (149.0)  |
| <b>Other standard flanges</b>       |               |                |                |              |              |                 |               |
| ANSI 2 inch, 150 lb                 | 6.00 (152.4)  | 0.75 (19.0)    | 0.69 (17.5)    | 0.060 (1.52) | 3.63 (92.1)  | 4               | 4.75 (120.6)  |
| ANSI 2 inch, 300 lb                 | 6.50 (165.1)  | 0.87 (22.2)    | 0.81 (20.7)    | 0.060 (1.52) | 3.63 (92.1)  | 8               | 5.00 (127.0)  |
| ANSI 3 inch, 150 lb                 | 7.50 (190.5)  | 0.94 (23.8)    | 0.88 (22.3)    | 0.060 (1.52) | 5.00 (127.0) | 4               | 6.00 (152.4)  |
| ANSI 3 inch, 300 lb                 | 8.25 (209.5)  | 1.12 (28.6)    | 1.06 (27.1)    | 0.060 (1.52) | 5.00 (127.0) | 8               | 6.63 (168.3)  |
| ANSI 3 inch, 600 lb <sup>(2)</sup>  | 8.25 (209.5)  | 1.50 (38.1)    | 1.25 (31.8)    | 0.25 (6.35)  | 5.00 (127.0) | 8               | 6.63 (168.3)  |
| ANSI 4 inch, 150 lb                 | 9.00 (228.6)  | 0.94 (23.8)    | 0.88 (22.3)    | 0.060 (1.52) | 6.19 (157.2) | 8               | 7.50 (190.5)  |
| ANSI 4 inch, 300 lb                 | 10.00 (254.0) | 1.25 (31.8)    | 1.19 (30.3)    | 0.060 (1.52) | 6.19 (157.2) | 8               | 7.87 (200.0)  |
| ANSI 4 inch, 600 lb <sup>(2)</sup>  | 10.75 (273.0) | 1.75 (44.5)    | 1.50 (38.1)    | 0.25 (6.35)  | 6.19 (157.2) | 8               | 8.50 (215.9)  |
| ANSI 6 inch, 150 lb                 | 11.00 (279.4) | 1.00 (25.4)    | 0.94 (23.9)    | 0.060 (1.52) | 8.50 (215.9) | 8               | 9.50 (241.3)  |
| EN (DIN) DN50, PN40 <sup>(3)</sup>  | 6.50 (165.0)  | 0.79 (20.0)    | 0.79 (20.0)    | 0            | NA           | 4               | 4.92 (125.0)  |
| EN (DIN) DN80, PN16 <sup>(3)</sup>  | 7.87 (200.0)  | 0.79 (20.0)    | 0.79 (20.0)    | 0            | NA           | 8               | 6.30 (160.0)  |
| EN (DIN) DN80, PN40 <sup>(3)</sup>  | 7.87 (200.0)  | 0.94 (24.0)    | 0.94 (24.0)    | 0            | NA           | 8               | 6.30 (160.0)  |
| EN (DIN) DN100, PN16 <sup>(3)</sup> | 8.66 (220.0)  | 0.79 (20.0)    | 0.79 (20.0)    | 0            | NA           | 8               | 7.09 (180.0)  |
| EN (DIN) DN100, PN40 <sup>(3)</sup> | 9.25 (235.0)  | 0.94 (24.0)    | 0.94 (24.0)    | 0            | NA           | 8               | 7.48 (190.0)  |
| EN (DIN) DN150, PN16 <sup>(3)</sup> | 11.22 (285.0) | 0.87 (22.0)    | 0.87 (22.0)    | 0            | NA           | 8               | 9.45 (240.0)  |

(1) Flange with recessed face.

(2) Can be ordered as special option, but the transmitter might not have full performance for high pressure, see diagram on page Level-8

(3) Flange with flat face.

### NOTE

The dimensions shown above may be used to aid in the identification of installed flanges. It is not intended for manufacturing use.

### NOTE

Flange and probe are always welded together when the probe is ordered with a flange.

# Ordering Information

## Model Code 3301, Level in Liquids

| Model | Product Description  |                              |  |
|-------|--|------------------------------|--|
| 3301  | Guided Wave Radar Level Transmitter (interface available for fully immersed probe) |                              |  |
| Code  | Signal Output  |                              |  |
| H     | 4-20 mA with HART® communication   |                              |  |
| Code  | Housing Material   |                              |  |
| A     | Polyurethane-covered Aluminum  |                              |  |
| Code  | Conduit / Cable Threads  |                              |  |
| 1     | ½ - 14 NPT   |                              |  |
| 2     | M20 x 1.5 adapter  |                              |  |
| 3     | PG 13.5 adapter  |                              |  |
| Code  | Operating Temperature and Pressure   |                              |  |
| S     | - 15 psig (-1bar) to 580 psig (40 bar) @ 302 °F (150 °C) <sup>(1)</sup>            |                              |  |
| Code  | Material of Construction: Process Connection / Probe                               |                              |  |
| 1     | 316 / 316 L SST (EN 1.4404), Teflon (PTFE, PFA)                                    |                              |  |
| Code  | Sealing, O-ring Material (Consult factory for other o-ring materials)              |                              |  |
| V     | Viton  |                              |  |
| E     | Ethylene Propylene   |                              |  |
| K     | Kalrez 6375  |                              |  |
| B     | Buna-N   |                              |  |
| Code  | Probe Type   | Process Connection           | Probe Lengths                                      |
| 1A    | Rigid Twin Lead  | Flange or 1.5 inch Thread    | Min: 1 ft 4 in. (0.4 m). Max: 9 ft 10 in. (3 m)    |
| 2A    | Flexible Twin Lead with weight   | Flange or 1.5 inch Thread    | Min: 3 ft 4 in. (1 m)<br>Max: 77 ft 1 in. (23.5 m) |
| 3A    | Coaxial  | Flange, 1 or 1.5 inch Thread | Min: 1 ft 4 in. (0.4 m). Max: 19 ft 8 in. (6 m)    |
| 3B    | Coaxial, perforated for easier cleaning  | Flange, 1 or 1.5 inch Thread | Min: 1 ft 4 in. (0.4 m). Max: 19 ft 8 in. (6 m)    |
| 4A    | Rigid Single Lead  | Flange, 1 or 1.5 inch Thread | Min: 1 ft 4 in. (0.4 m). Max: 9 ft 10 in. (3 m)    |
| 5A    | Flexible Single Lead with weight   | Flange, 1 or 1.5 inch Thread | Min: 3 ft 4 in. (1 m)<br>Max: 77 ft 1 in. (23.5 m) |
| 5B    | Flexible Single Lead with chuck <sup>(2)</sup>                                     | Flange, 1 or 1.5 inch Thread | Min: 3 ft 4 in. (1 m)<br>Max: 77 ft 1 in. (23.5 m) |
| Code  | Probe Length Units   |                              |  |
| E     | English (feet, inch)   |                              |  |
| M     | Metric (meters, centimeters)   |                              |  |
| Code  | Total Probe Length <sup>(3)</sup> (feet/m)   |                              |  |
| xx    | 0 - 77 ft or 0-23 m  |                              |  |
| Code  | Total Probe Length <sup>(3)</sup> (inch/cm)  |                              |  |
| xx    | 0 - 11 inch or 0-99 cm   |                              |  |

Table continued on next page

(1) Process seal rating. Final rating depends on flange and O-ring selection. See "Tank Connection" on page Level-8.  
 (2) Extra length for fastening is added in factory.  
 (3) Probe weight included if applicable. Give the total probe length in feet and inches or meters and centimeters, depending on selected probe length unit (see page Level-26). If tank height is unknown, please round up to an even length when ordering. Probes can be cut to exact length in field. Maximum allowable length is determined by process conditions. See "Replacing Displacer in an Existing Displacer Cage" on page 13 for more probe length guidance.

# Rosemount 3300 Series

## Model Code 3301, Level in Liquids, continued

| Code  | Process Connection - Size / Type (consult factory for other process connections)   |
|---|--|
| <b>ANSI Flanges in 316L SST (EN 1.4404)</b>     |  |
| AA  | 2 inch ANSI, 150 lb  |
| AB  | 2 inch ANSI, 300 lb  |
| BA  | 3 inch ANSI, 150 lb  |
| BB  | 3 inch ANSI, 300 lb  |
| CA  | 4 inch ANSI, 150 lb  |
| CB  | 4 inch ANSI, 300 lb  |
| DA  | 6 inch ANSI, 150 lb  |
| <b>EN (DIN) Flanges in 316L SST (EN 1.4404)</b> |  |
| HB  | DN50, PN40   |
| IA  | DN80, PN16   |
| IB  | DN80, PN40   |
| JA  | DN100, PN16  |
| JB  | DN100, PN40  |
| KA  | DN150, PN16  |
| <b>Threaded Connections</b>                     |  |
| RA  | 1 ½ inch NPT thread  |
| RB  | 1 inch NPT thread (only available for probe type 3A, 3B, 4A, 5A, 5B)   |
| SA  | 1 ½ inch BSP (G 1 ½ inch) thread   |
| SB  | 1 inch BSP (G 1 inch) thread (only available for probe type 3A, 3B, 4A, 5A, 5B)  |
| <b>Proprietary Flanges</b>                      |  |
| TF  | Fisher - proprietary 316 Stainless Steel (for 249B cages) Torque Tube Flange   |
| TT  | Fisher - proprietary 316 Stainless Steel (for 249C cages) Torque Tube Flange   |
| TM  | Masonellan - proprietary 316 Stainless Steel Torque Tube Flange  |
| <b>Code Hazardous Locations Certifications</b>  |  |
| NA  | No Hazardous Locations Certifications  |
| E1  | ATEX Flameproof  |
| E5  | FM Explosion Proof   |
| E6  | CSA Explosion Proof  |
| I1  | ATEX Intrinsic Safety  |
| I5  | FM Intrinsic Safety and Non-Incendive  |
| I6  | CSA Intrinsic Safety and Non-Incendive   |
| <b>Code Options</b>                             |  |
| M1  | Integral digital display   |
| BT  | Bar Code Tag with tag number and purchase order number   |
| P1  | Hydrostatic testing  |
| N2  | NACE material recommendation per MR 01-75 <sup>(1)</sup>   |
| LS  | Long stud 9.8 in. (250 mm) for flexible single lead probe. Prevents the wire from contacting wall / nozzle. Standard height is 3.9 in. (100 mm). |
| <b>Cx - Special Configuration (Software)</b>    |  |
| C1  | Factory configuration (CDS required with order)  |
| C4  | Namur alarm and saturation levels, high alarm  |
| C5  | Namur alarm and saturation levels, low alarm   |
| C8  | Low alarm <sup>(2)</sup> (standard Rosemount alarm and saturation levels)  |
| <b>Qx - Special Certs</b>                       |  |
| Q4  | Calibration Data Certification   |
| Q8  | Material Traceability Certification per EN 10204 3.1B5 <sup>(3)</sup>  |

(1) Valid for probe type 3A, 3B and 4A.

(2) The standard alarm setting is high.

(3) Option available for pressure retaining wetted parts.

**Example Model String: 3301-H-A-1-S-1-V-1A-M-02-05-AA-I1-M1C1**

**E-02-05** in model string means 2 ft and 5 inch probe length. **M-02-05** means 2.05 m probe length.

**Model Code 3302, Level and Interface in Liquids**

|                                     |  |                              |  |
|-------------------------------------|--|------------------------------|--|
| <b>Model</b>                        | <b>Product Description</b>   |                              |  |
| 3302                                | Guided Wave Radar Level and Interface Transmitter                            |                              |  |
| <b>Code</b>                         | <b>Signal Output</b>   |                              |  |
| H                                   | 4-20 mA with HART® communication   |                              |  |
| <b>Code</b>                         | <b>Housing Material</b>  |                              |  |
| A                                   | Polyurethane-covered Aluminum  |                              |  |
| <b>Code</b>                         | <b>Conduit / Cable Threads</b>   |                              |  |
| 1                                   | ½ - 14 NPT   |                              |  |
| 2                                   | M20 x 1.5 adapter  |                              |  |
| 3                                   | PG 13.5 adapter  |                              |  |
| <b>Code</b>                         | <b>Operating Temperature and Pressure</b>                                    |                              |  |
| S                                   | - 15 psig (-1bar) to 580 psig (40 bar) @ 302 °F (150 °C) <sup>(1)</sup>      |                              |  |
| <b>Code</b>                         | <b>Material of Construction: Process Connection / Probe</b>                  |                              |  |
| 1                                   | 316 / 316 L SST (EN 1.4404), Teflon (PTFE, PFA)                              |                              |  |
| <b>Code</b>                         | <b>Sealing, O-ring Material (Consult factory for other o-ring materials)</b> |                              |  |
| V                                   | Viton  |                              |  |
| E                                   | Ethylene Propylene   |                              |  |
| K                                   | Kalrez 6375  |                              |  |
| B                                   | Buna-N   |                              |  |
| <b>Code</b>                         | <b>Probe Type</b>  | <b>Process Connection</b>    | <b>Probe Lengths</b>                               |
| 1A                                  | Rigid Twin Lead  | Flange or 1.5 inch Thread    | Min: 1 ft 4 in. (0.4 m). Max: 9 ft 10 in. (3 m)    |
| 2A                                  | Flexible Twin Lead with weight   | Flange or 1.5 inch Thread    | Min: 3 ft 4 in. (1 m)<br>Max: 77 ft 1 in. (23.5 m) |
| 3B                                  | Coaxial for interface measurements   | Flange, 1 or 1.5 inch Thread | Min: 1 ft 4 in. (0.4 m). Max: 19 ft 8 in. (6 m)    |
| 4A                                  | Rigid Single Lead  | Flange, 1 or 1.5 inch Thread | Min: 1 ft 4 in. (0.4 m). Max: 9 ft 10 in. (3 m)    |
| <b>Code</b>                         | <b>Probe Length Units</b>  |                              |  |
| E                                   | English (feet, inch)   |                              |  |
| M                                   | Metric (meters, centimeters)   |                              |  |
| <b>Code</b>                         | <b>Total Probe Length <sup>(2)</sup> (feet/m)</b>                            |                              |  |
| xx                                  | 0 - 77 ft or 0-23 m  |                              |  |
| <b>Code</b>                         | <b>Total Probe Length <sup>(3)</sup> (inch/cm)</b>                           |                              |  |
| xx                                  | 0 - 11 inch or 0-99 cm   |                              |  |
| <b>Table continued on next page</b> |  |                              |  |

(1) Process seal rating. Final rating depends on flange and O-ring selection. See "Tank Connection" on page 8.  
(2) Probe weight included if applicable. Give the total probe length in feet and inches or meters and centimeters, depending on selected probe length unit (see page Level-28). If tank height is unknown, please round up to an even length when ordering. Probes can be cut to exact length in field. Maximum allowable length is determined by process conditions. See "Replacing Displacer in an Existing Displacer Cage" on page 13 for more probe length guidance.

# Rosemount 3300 Series

## Model Code 3302, Level and Interface in Liquids, continued

| Code   | Process Connection - Size / Type (consult factory for other process connections) |
|--|--|
| <b>ANSI Flanges in 316L SST (EN 1.4404)</b>  |  |
| AA   | 2 inch ANSI, 150 lb  |
| AB   | 2 inch ANSI, 300 lb  |
| BA   | 3 inch ANSI, 150 lb  |
| BB   | 3 inch ANSI, 300 lb  |
| CA   | 4 inch ANSI, 150 lb  |
| CB   | 4 inch ANSI, 300 lb  |
| DA   | 6 inch ANSI, 150 lb  |
| <b>EN (DIN) Flanges in 316L SST (EN 1.4404)</b>  |  |
| HB   | DN50, PN40   |
| IA   | DN80, PN16   |
| IB   | DN80, PN40   |
| JA   | DN100, PN16  |
| JB   | DN100, PN40  |
| KA   | DN150, PN16  |
| <b>Threaded Connections</b>  |  |
| RA   | 1 ½ inch NPT thread  |
| RB   | 1 inch NPT thread (only available for probe type 3B and 4A)                      |
| SA   | 1 ½ inch BSP (G 1 ½ inch) thread   |
| SB   | 1 inch BSP (G 1 inch) thread (only available for probe type 3B and 4A)           |
| <b>Proprietary Flanges. See "Replacing Displacer in an Existing Displacer Cage" on page Level-13</b> |  |
| TF   | Fisher - proprietary 316 Stainless Steel (for cage 249B) Torque Tube Flange      |
| TT   | Fisher - proprietary 316 Stainless Steel (for cage 249C) Torque Tube Flange      |
| TM   | Masonellan - proprietary 316 Stainless Steel Torque Tube Flange                  |
| <b>Code Hazardous Locations Certifications</b>   |  |
| NA   | No Hazardous Locations Certifications  |
| E1   | ATEX Flameproof  |
| E5   | FM Explosion Proof   |
| E6   | CSA Explosion Proof  |
| I1   | ATEX Intrinsic Safety  |
| I5   | FM Intrinsic Safety and Non-Incendive  |
| I6   | CSA Intrinsic Safety and Non-Incendive   |
| <b>Code Options</b>  |  |
| M1   | Integral digital display   |
| BT   | Bar Code Tag with tag number and purchase order number                           |
| P1   | Hydrostatic testing  |
| N2   | NACE material recommendation per MR 01-75 <sup>(1)</sup>                         |
| <b>Cx - Special Configuration (Software)</b>   |  |
| C1   | Factory configuration (CDS required with order)                                  |
| C4   | Namur alarm and saturation levels, high alarm                                    |
| C5   | Namur alarm and saturation levels, low alarm                                     |
| C8   | Low alarm <sup>(2)</sup> (standard Rosemount alarm and saturation levels)        |
| <b>Qx - Special Certs</b>  |  |
| Q4   | Calibration Data Certification   |
| Q8   | Material Traceability Certification per EN 10204 3.1B5 <sup>(3)</sup>            |

(1) Valid for probe type 3B and 4A.

(2) The standard alarm setting is high.

(3) Option available for pressure retaining wetted parts.

**Example Model String: 3302-H-A-1-S-1-V-1A-M-02-05-AA-11-M1C1**  
E-02-05 in model string means 2 ft and 5 inch probe length. M-02-05 means 2.05 m probe length.



# Rosemount 3300 Series

## Rosemount 3301, Level in Liquids, cont.

### LCD Meter Configuration - Only if M1 and C1 is ordered

Variables  Level  Distance  Volume  % of Range  
 Variable units according to previous page. Carousel Toggling is used to present more than one variable.

### Security Information - Information is required if C1 is ordered

Write Protect  On  Off \*

### Process Information (information intended for pre-ordering support)

**Process Temperature** Min: \_\_\_\_\_ Max: \_\_\_\_\_  °F  °C  
**Process Pressure** Min: \_\_\_\_\_ Max: \_\_\_\_\_  psig  Bar  
**Viscosity:** \_\_\_\_\_  cP  cst **at Temperature:** \_\_\_\_\_  °F  °C  
**Product Build-up Potential**  None  Film  Bridging  
**Is the process turbulent?**  No  Slightly  Aggressive  
 If turbulent, due to  Agitation  Vortex  Flowing  
**Foam**  None  Light, airy  Heavy, dense  Sticky  
 If foam, it is present  Constantly  Occasionally  
 If foam, thickness \_\_\_\_\_  inch  cm  
 If foam, what part of the foam layer do you wish to measure?  top  bottom

### Fitting Dimensions (information intended for pre-ordering support)

Please fill in the dimensions (according to selected variable unit)

Nozzle

Stilling Well or Bypass Pipe

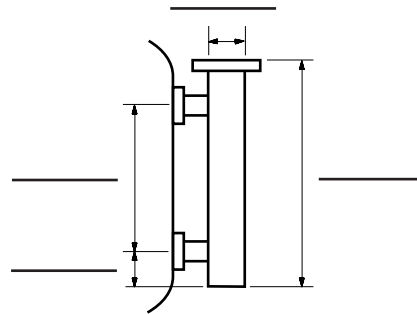
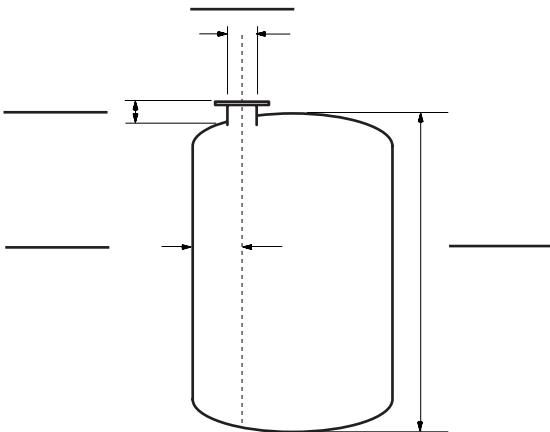

**Other metallic object closer than 7.9 in. (20 cm) from the probe**  Yes  No  
 If yes, how close? \_\_\_\_\_  inch  cm



# Rosemount 3300 Series

## Rosemount 3301, Interface, Fully Submerged Probe in Liquids, cont.

### LCD Meter Configuration - Only if M1 and C1 is ordered

Variables  Interface Level  Interface Distance / Upper Product Thickness  % of Range  
 Variable units according to previous page. Carousel Toggling is used to present more than one variable.

### Security Information - Information is required if C1 is ordered

Write Protect  On  Off \*

### Process Information (information intended for pre-ordering support)

**Process Temperature** Min: \_\_\_\_\_ Max: \_\_\_\_\_  °F  °C  
**Process Pressure** Min: \_\_\_\_\_ Max: \_\_\_\_\_  psig  Bar  
**Viscosity:** \_\_\_\_\_  cP  cst **at Temperature:** \_\_\_\_\_  °F  °C  
**Product Build-up Potential**  None  Film  Bridging  
**Is the process turbulent?**  No  Slightly  Aggressive  
 If turbulent, due to  Agitation  Vortex  Flowing  
**Emulsion Layer**  No  Yes  
 If emulsion layer, thickness \_\_\_\_\_  inch  cm

### Fitting Dimensions (information intended for pre-ordering support)

Please fill in the dimensions (according to selected variable unit)

Nozzle  Stilling Well or Bypass Pipe

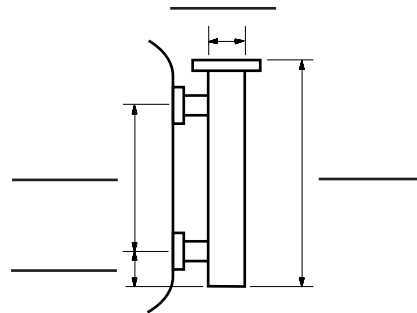
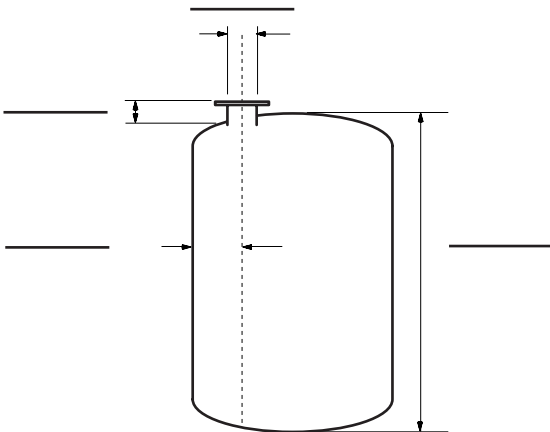

**Other metallic object closer than 7.9 in. (20 cm) from the probe**  Yes  No  
 If yes, how close? \_\_\_\_\_  inch  cm



# Rosemount 3300 Series

## Rosemount 3302, Level and Interface in Liquids, cont.

### LCD Meter Configuration - Only if M1 and C1 is ordered

Variables  Level  Distance  Volume  Interface Level  Interface Distance  Upper Product Thickness  
 % of Range

Variable units according to previous page. Carousel Toggling is used to present more than one variable.

### Security Information - Information is required if C1 is ordered

Write Protect  On  Off \*

### Process Information (information intended for pre-ordering support)

**Process Temperature** Min: \_\_\_\_\_ Max: \_\_\_\_\_  °F  °C  
**Process Pressure** Min: \_\_\_\_\_ Max: \_\_\_\_\_  psig  Bar  
**Viscosity:** \_\_\_\_\_  cP  cst **at Temperature:** \_\_\_\_\_  °F  °C  
**Product Build-up Potential**  None  Film  Bridging  
**Is the process turbulent?**  No  Slightly  Aggressive  
 If turbulent, due to  Agitation  Vortex  Flowing  
**Emulsion Layer**  No  Yes  
 If emulsion layer, thickness \_\_\_\_\_  inch  cm

### Fitting Dimensions (information intended for pre-ordering support)

Please fill in the dimensions (according to selected variable unit)

Nozzle  Stilling Well or Bypass Pipe

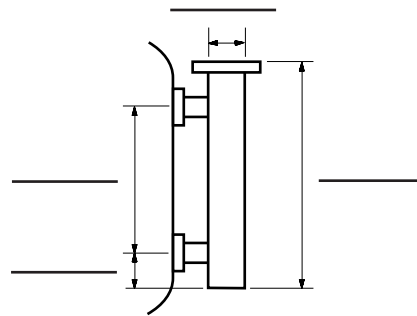
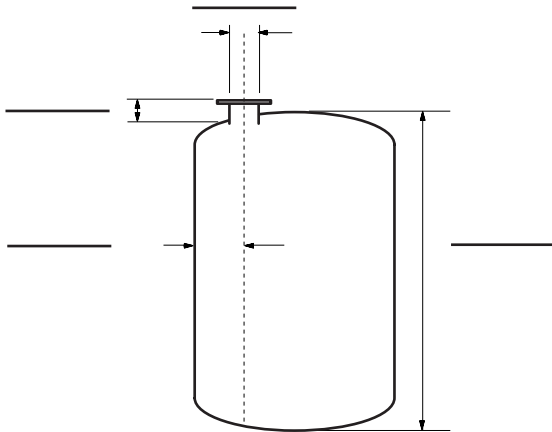

**Other metallic object closer than 7.9 in. (20 cm) from the probe**  Yes  No  
If yes, how close? \_\_\_\_\_  inch  cm

# Application & Configuration Data Sheets

## VOLUME CONFIGURATION

**Volume Configuration Information (total volume calculation only) - Required if C1 is ordered and Volume is chosen variable**

Volume will be calculated based on ideal tank types or strapping table. Please fill in those boxes that correspond to your tank (according to selected variable units)

Vertical Cylinder

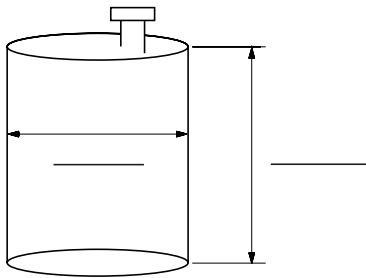

Horizontal Cylinder

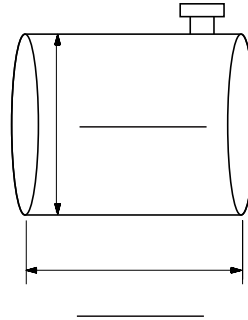

Vertical Cylinder with Bullet Ends

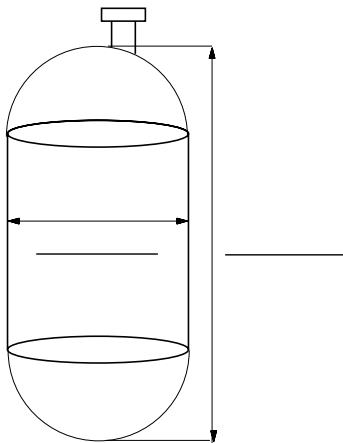

Horizontal Cylinder with Bullet Ends

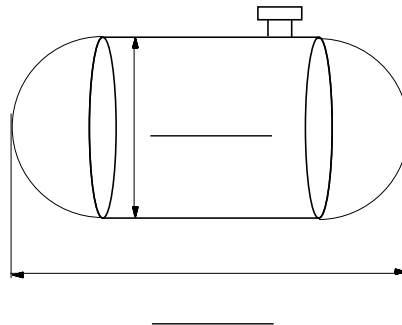

Strapping Table (10 points max)

(Needed for cone bottoms, sloped bottoms, dished bottoms, dished ends, irregular-shaped tanks, tanks with internal equipment etc).

Sphere

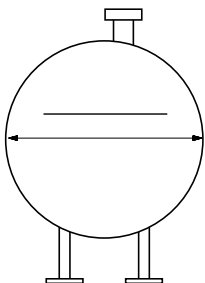

| Strapping Point | Level | Volume |
|-----------------|-------|--------|
| 0 (bottom)      |       |        |
| 1               |       |        |
| 2               |       |        |
| 3               |       |        |
| 4               |       |        |
| 5               |       |        |
| 6               |       |        |
| 7               |       |        |
| 8               |       |        |
| 9 (top)         |       |        |

# Rosemount 3300 Series

---

**Product Data Sheet**  
00813-0100-4811, Rev AC  
Catalog 2004

*Rosemount and the Rosemount logotype are registered trademarks of Rosemount Inc.  
PlantWeb is a registered trademark of one of the Emerson Process Management group of companies.  
All other marks are the property of their respective owners.*

## **Emerson Process Management**

### **Rosemount Division**

8200 Market Boulevard  
Chanhassen, MN 55317 USA  
T (U.S.) 1-800-999-9307  
T (International) (952) 906-8888  
F (952) 949-7001

[www.rosemount.com](http://www.rosemount.com)



### **Emerson Process Management**

Heath Place  
Bognor Regis  
West Sussex PO22 9SH  
England  
Tel 44 (1243) 863 121  
Fax 44 (1243) 867 5541

### **Emerson Process Management Asia Pacific Private Limited**

1 Pandan Crescent  
Singapore 128461  
T (65) 6777 8211  
F (65) 6777 0947  
[AP.RMT-Specialist@emersonprocess.com](mailto:AP.RMT-Specialist@emersonprocess.com)



**EMERSON**  
Process Management