

## XYR 5000

## WG510/WA510

### Wireless Gauge and Absolute Pressure Transmitters

34-XY-01-01 10/2003

PRODUCT SPECIFICATION AND MODEL SELECTION GUIDE

#### Function

The WG/A510 is part of the XYR 5000 family of wireless products. These transmitters cover a wide pressure range, and can be used to monitor a variety of processes and assets in hazardous and remote areas. Since there are no wires to run, the transmitter can be installed and operational in minutes, quickly providing information about the variable being monitored. The Smart Response Manager allows the transmitter to adapt to changing process conditions, allowing greater visibility to process variation. Smart Response Manager allows the user to set thresholds which, when exceeded, cause the transmitter to adjust sampling and data transmission rates.

The transmitter combines a high accuracy piezoresistive sensor with a Radio Frequency (RF) transceiver that communicates in a digital protocol, using Frequency Hopping Spread Spectrum (FHSS). FHSS ensures data integrity by continually switching the carrier wave over a wide range of frequencies. Power is supplied by a C size 3.6 V lithium battery, with an expected lifetime of up to five years.

Enjoy the benefits of wireless technology today:

Improve Product Quality, Ensure High Uptime, Reduce Maintenance and Operational Costs, Meet Regulatory Requirements, and Enhance Flexibility.

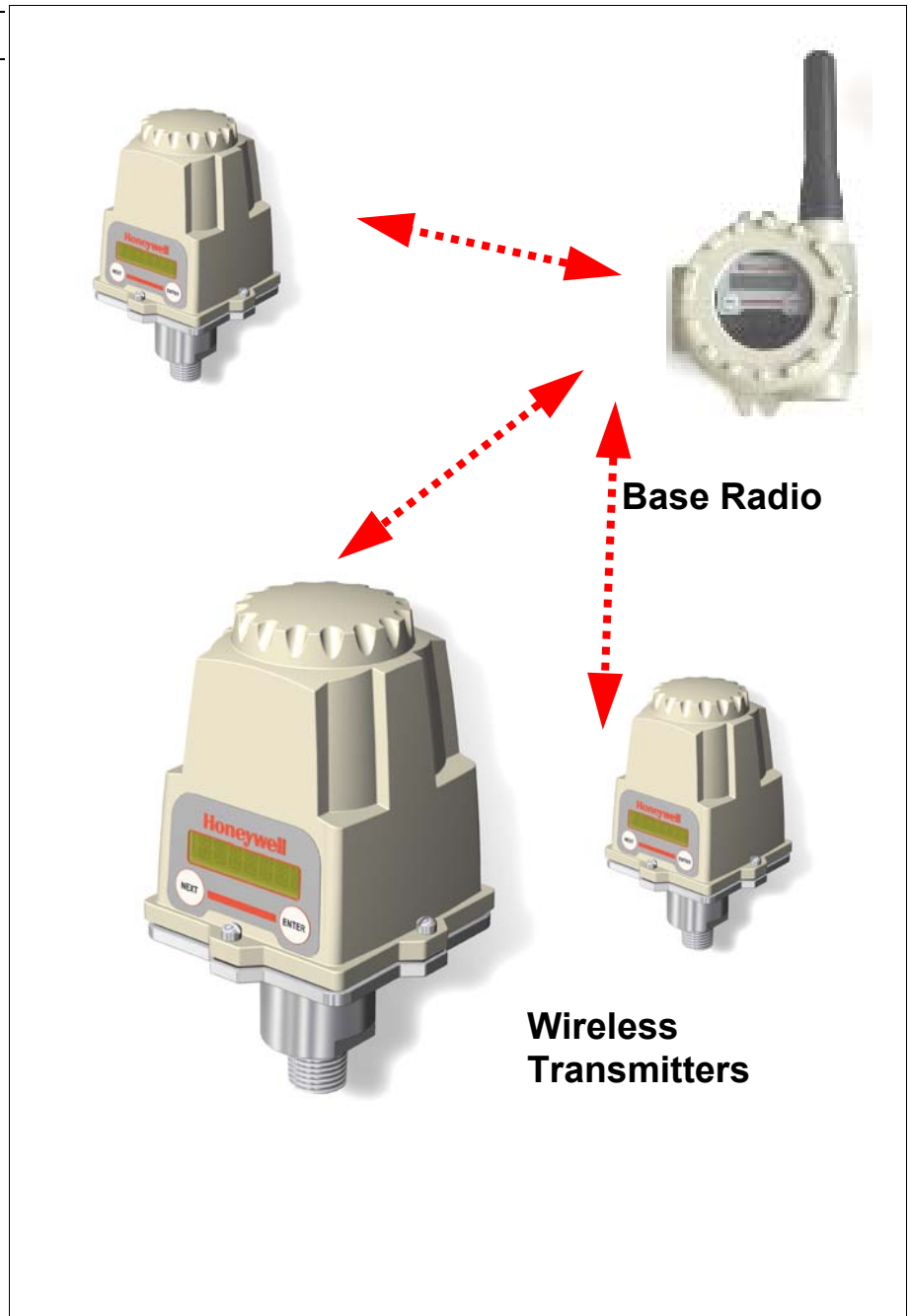

## MODELS

### Gauge Pressure

Model #	UPPER RANGE LIMIT	OVERLOAD LIMIT	DIAPHRAGM/BODY MATERIAL
	PSIG	PSIG	(wetted parts)
WG511	0 - 30	60	316L SS/316 SS
WG512	0 - 250	500	316L SS/316 SS
WG513	0 - 1000	2000	316L SS/316 SS
WG514	0 - 5000	12000	17-4 pH/316 SS

### Absolute Pressure

Model #	UPPER RANGE LIMIT	OVERLOAD LIMIT	DIAPHRAGM MATERIAL
	PSIA	PSIA	
WA515	0 - 30	60	316L SS/316 SS
WA516	0 - 250	500	316L SS/316 SS

## WIRELESS GENERAL SPECIFICATIONS

<b>Wireless Communication</b>	902 MHz – 928 MHz Frequency Hopping Spread Spectrum (FHSS) FCC certified ISM license-free band. Every data block transmitted is verified (CRC check) and acknowledged by the Base Radio.
<b>RF Transmit Power</b>	31 mW, 17.8 mW typical.
<b>Data Rate</b>	Configurable: 4.8 Kbps, 19.2 Kbps, or 76.8 Kbps.
<b>Antenna</b>	Internal 3" omni-directional, ¼ wave, monopole.
<b>Signal Range</b>	Up to 2000 feet (600 meters) from Base Radio with clear line of sight.*

\*Actual range may vary depending on site topography.

## SELF DIAGNOSTICS

Self-checking software and hardware that identifies and reports out of spec conditions, and field unit low battery voltage.

## OPERATING/STORAGE CONDITIONS

<b>Humidity</b>	99% RH (non-condensing).
<b>Temperature</b>	Ambient Sensor: -40 to +230°F (-40 to +110°C) Ambient Electronics: -40 to +185°F (-40 to +85°C) Process fluid: -40 to +250°F (-40 to +121°C) Display (Full visibility): -4 to +158°F (-20 to +70°C) Display (Reduced visibility): -40 to +185°F (-40 to +85°C) Storage: -58 to +185°F (-50 to +85°C).

## DEVICE CONFIGURATION

<b>Parameter Configuration</b>	<ul style="list-style-type: none"> <li>• RF Channel Setup: 1 to 16.</li> <li>• Baud Rate: 4.8 Kbps, 19.2 Kbps, 76.8 Kbps.</li> <li>• RF ID: 1 to 50.</li> <li>• Password.</li> <li>• Tag Name (up to 21 characters).</li> <li>• Normal Transmit Rate: (1–5 sec, 10 sec, 15 sec, 20 sec, 40 sec, 1 min).</li> <li>• Normal Sampling Rate: (1–10 sec, 15 sec, 20 sec, 30 sec, 1 min).</li> <li>• Abnormal Transmit Rate: (1–5 sec, 10 sec, 15 sec, 20 sec, 40 sec, 1 min).</li> <li>• Abnormal Sampling Rate: (1–10 sec, 15 sec, 20 sec, 30 sec).</li> <li>• Pressure Normal Upper Value: Disabled/Enabled. Enabled to change Sampling and Transmit rates during abnormal process conditions.</li> <li>• Pressure Normal Lower Value: Disabled/Enabled. Enabled to change Sampling and Transmit rates during abnormal process conditions.</li> <li>• Engineering Units: PSI, bar, mBar, Pa, kPa, Torr, Atm, inH2O, inHg, ftH2O, mmHg, g/cm2, kg/cm2.</li> <li>• Pressure Zero.</li> <li>• Offset: User defined offset will be transmitted instead of actual value.</li> <li>• Trim: Applies a user-defined one- or two-point correction curve to the actual value.</li> </ul>
<b>Configuration Panel</b>	<p>Integrated LCD display with membrane switch buttons for local configuration. LCD display is 7-digit (alternating) high contrast, anti-reflective monochrome. Display cycles between pressure level and RF status.</p>

## PERFORMANCE

<b>Accuracy (linearity and hysteresis)</b>	$\pm 0.1\%$ FS over temperature.
<b>Combined Zero and Span Stability</b>	Less than $\pm 0.1\%$ of sensor URL per year @ 21°C (70°F).
<b>Resolution</b>	24-bit A/D converter.

## PHYSICAL SPECIFICATIONS

<b>Process connections</b>	1/2" - NPTM.
<b>Base Material (bob-wetted)</b>	304 SS
<b>Electronic Housing</b>	GE Lexan. V0 Rating and UV Stable.
<b>Vibration and Shock</b>	Certified per IEC EN00068 2-6 (Vibration) and 2-27 (Shock)
<b>Random Vibration</b>	Certified to withstand 6 g's, 15 minutes per axis from 9 – 500 Hz.
<b>Net weight</b>	1 kg (2 lbs).
<b>Electromagnetic Compatibility (CE Compliance)</b>	Operates within Specifications in fields from 80 to 1,000 MHz with Field Strengths to 30 V/m. Meets EN 50082-1 General Immunity Standard and EN 55011 Compatibility Emissions Standard.

## APPROVALS

<b>Environmental protection</b>	NEMA 4X (pending)..
<b>Electrical classification</b>	FM Rated Intrinsically Safe for Class I, Div. 1, Groups A,B,C,D; Class II, Div. 1, Groups E,F,G; Class III, Div. 1 (pending)..

## DIMENSIONS

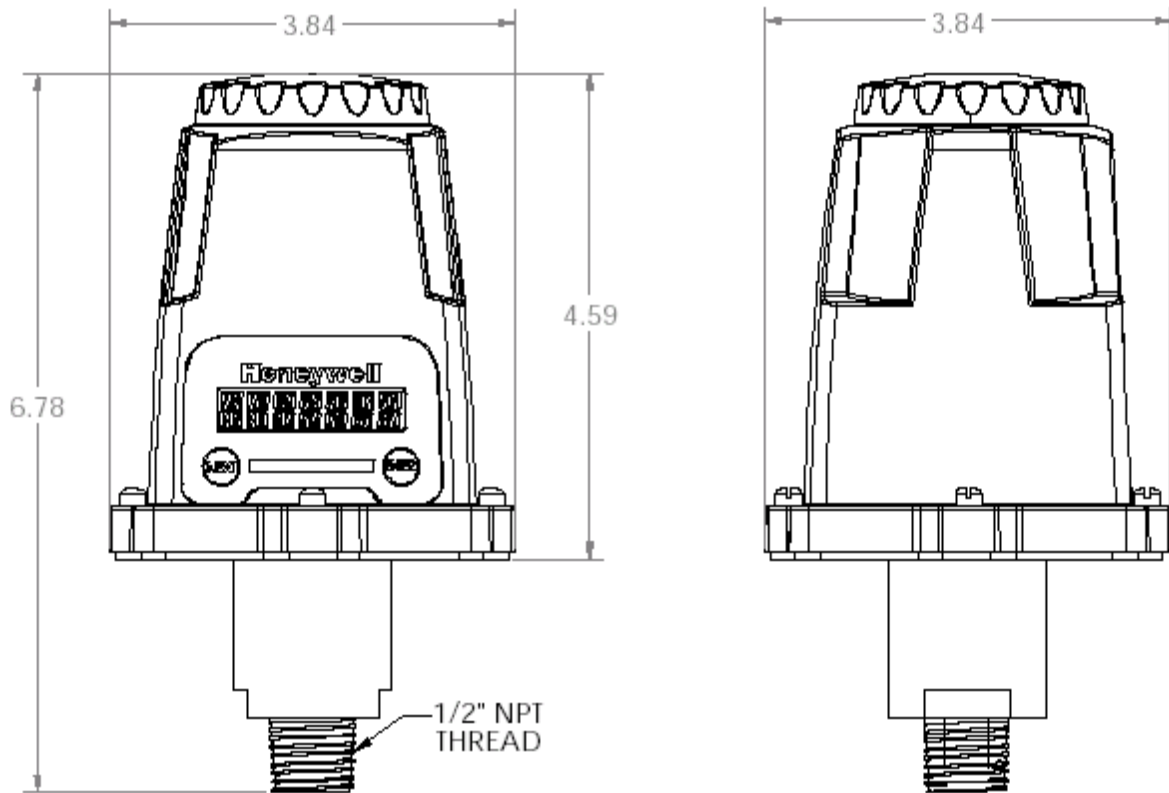

# XYR 5000 Wireless Pressure Transmitters

Model Selection Guide  
34-XY-16-01 Issue 0

Honeywell Confidential & Proprietary

## Instructions

- Select the desired key number.

**Key Number**

-----

KEY NUMBER		Selection
Description	Span	
Gauge Pressure Transmitter	0 - 0.3 to 0 - 30 PSIG	WG511
Gauge Pressure Transmitter	0 - 2.5 to 0 - 250 PSIG	WG512
Gauge Pressure Transmitter	0 - 10 to 0 - 1000 PSIG	WG513
Gauge Pressure Transmitter	0 - 50 to 0 - 5000 PSIG	WG514
Absolute Pressure Transmitter	0 - 0.3 to 0 - 30 PSIA	WA515
Absolute Pressure Transmitter	0 - 2.5 to 0 - 250 PSIA	WA516

