

Save This Manual
For Future Reference

SEARS

*owners
manual*

**MODEL NO.
113.228162
LATHE WITH MOTOR**

Serial
Number _____

Model and serial
number may be found
under belt guard.
You should record both
model and serial number
in a safe place for
future use.

CAUTION:

Read **GENERAL** and
ADDITIONAL SAFETY
INSTRUCTIONS
carefully

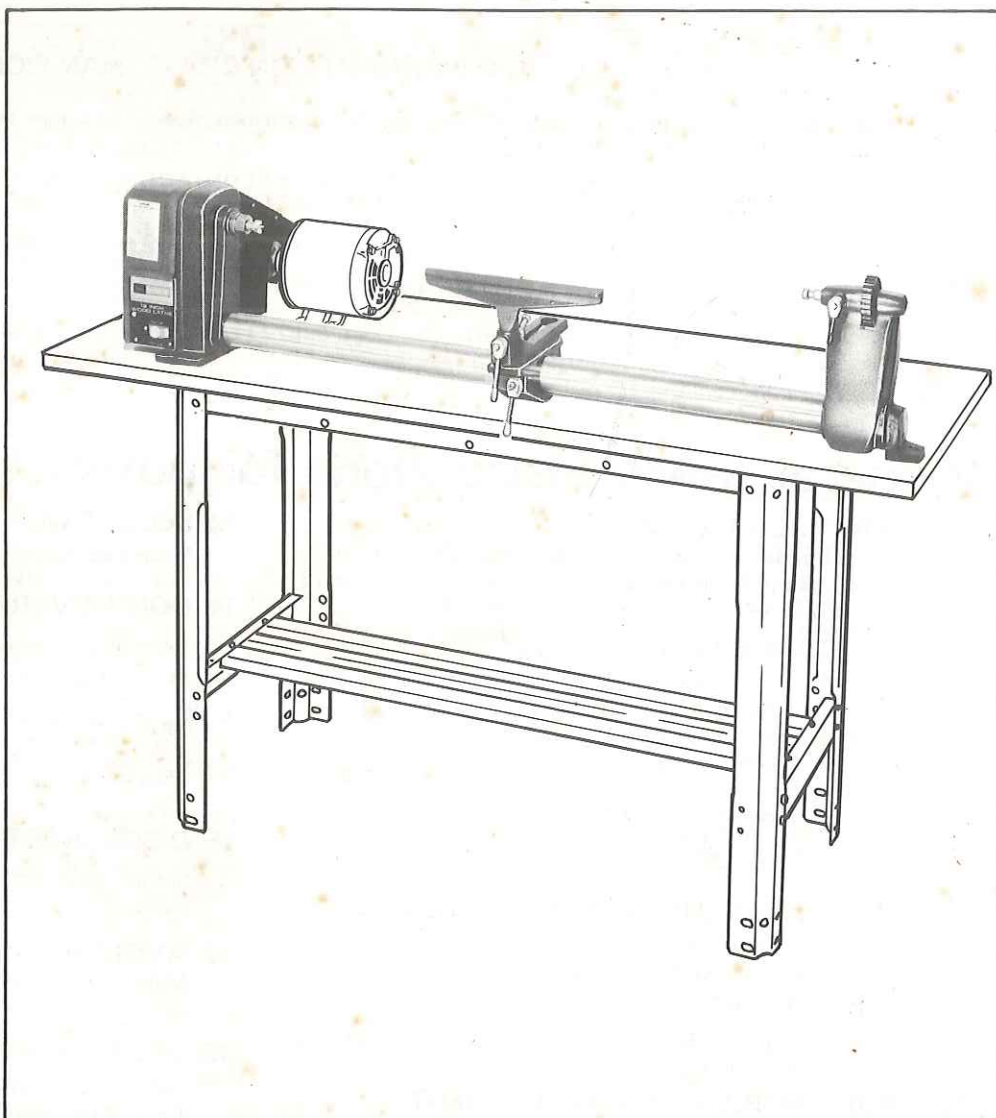

CRAFTSMAN
12-INCH
WOOD-TURNING LATHE

- *assembly*
- *operating*
- *repair parts*

Sold by SEARS, ROEBUCK AND CO., Chicago, IL. 60684 U.S.A.

FULL ONE YEAR WARRANTY ON CRAFTSMAN WOOD LATHE

If within one year from the date of purchase, this Craftsman Wood Lathe fails due to a defect in material or workmanship, Sears will repair it, free of charge.

WARRANTY SERVICE IS AVAILABLE BY SIMPLY CONTACTING THE NEAREST SEARS SERVICE CENTER/DEPARTMENT THROUGHOUT THE UNITED STATES.

THIS WARRANTY APPLIES ONLY WHILE THIS PRODUCT IS IN USE IN THE UNITED STATES.

This warranty gives you specific legal rights, and you may also have other rights which vary from state to state.

SEARS, ROEBUCK AND CO., Dept. 698/731A, Sears Tower, Chicago, IL 60684

general safety instructions for power tools

- 1. KNOW YOUR LATHE**
Read and understand owner's manual and labels affixed to the tool. Learn its application and limitations as well as its specific potential hazards peculiar to this tool.
- 2. GROUND THE LATHE**
This Lathe is equipped with an approved 3-conductor cord and a 3-prong grounding type plug to fit the proper grounding type receptacle. The green conductor in the cord is the grounding wire. Never connect the green wire to a live terminal.
- 3. KEEP GUARDS IN PLACE**
— in working order, and in proper adjustment and alignment.
- 4. REMOVE ADJUSTING KEYS AND WRENCHES**
Form habit of checking to see that keys and adjusting wrenches are removed from tool before turning it on.
- 5. KEEP WORK AREA CLEAN**
Cluttered areas and benches invite accidents. Floor must not be slippery due to wax or sawdust.
- 6. AVOID DANGEROUS ENVIRONMENT**
Don't use power tools in damp or wet locations or expose them to rain. Keep work area well lighted. Provide adequate surrounding work space.
- 7. KEEP CHILDREN AWAY**
All visitors should be kept a safe distance from work area.
- 8. MAKE WORKSHOP CHILD-PROOF**
— with padlocks, master switches, or by removing starter keys.
- 9. USE PROPER SPEED**
The Lathe will do the job better and safer when operated at the proper speed.
- 10. USE RIGHT TOOL**
Don't force tool or attachment to do a job for which it was not designed.
- 11. WEAR PROPER APPAREL**
Do not wear loose clothing, gloves, neckties or jewelry (rings; wristwatches) to get caught in moving parts. NONSLIP footwear is recommended. Wear protective hair covering to contain long hair. Roll long sleeves above the elbow.
- 12. USE SAFETY GOGGLES (Head Protection)**
Wear safety goggles (must comply with ANSI Z87.1) at all times. Everyday eyeglasses only have impact resistant lenses, they are NOT safety glasses. Also, use face or dust mask if cutting operation is dusty, and ear protectors (plugs or muffs) during extended periods of operation.
- 13. SECURE WORKPIECE**
Mount workpiece securely between centers.
- 14. DON'T OVERREACH**
Keep proper footing and balance at all times.
- 15. MAINTAIN TOOLS WITH CARE**
Keep tools sharp and clean for best and safest performance. Follow instructions for lubricating and changing accessories.
- 16. DISCONNECT YOUR LATHE**
before servicing; when changing accessories or attachments.
- 17. AVOID ACCIDENTAL STARTING**
Make sure switch is in "OFF" position before plugging in.
- 18. USE RECOMMENDED ACCESSORIES**
Consult this owner's manual for recommended accessories. Follow the instructions that accompany the accessories. The use of improper accessories may cause hazards.
- 19. NEVER STAND ON LATHE**
Serious injury could occur if the Lathe tips over.
Do not store materials such that it is necessary to stand on the tool to reach them.
- 20. CHECK DAMAGED PARTS**
Before further use of the Lathe, a guard or other part that is damaged should be carefully checked to ensure that it will operate properly and perform its intended function. Check for alignment of moving parts, binding of moving parts, breakage of parts, mounting, and any other conditions that may affect its operation. A guard or other part that is damaged should be properly repaired or replaced.
- 21. DIRECTION OF FEED**
Apply cutting tool to the workpiece against the direction of spindle rotation.
- 22. NEVER LEAVE LATHE RUNNING ATTENDED**
Turn power "OFF". Don't leave Lathe until it comes to a complete stop.

additional safety instructions for wood turning lathes

Safety is a combination of operator common sense and alertness at all times when the Lathe is being used.

WARNING: FOR YOUR OWN SAFETY, DO NOT ATTEMPT TO OPERATE YOUR LATHE UNTIL IT IS COMPLETELY ASSEMBLED AND INSTALLED ACCORDING TO THE INSTRUCTIONS . . . AND UNTIL YOU HAVE READ AND UNDERSTAND THE FOLLOWING:

	PAGE
1. General Safety Instructions	2
2. Getting to Know Your Lathe	11
3. Basic Lathe Operation	13
4. Maintenance	30

5. The Lathe and motor must be bolted down to a stand or workbench for stability.

6. Protection: Eyes, Hands, Face, Ears, Body

a. Wear safety goggles that comply with ANSI Z87.1-1968, and a face shield if operation is dusty. Wear ear plugs or muffs during extended periods of operation.

b. When turning between centers or on the faceplate, always rough-out "out of round" workpieces at slow speed. Running the Lathe too fast, so that it vibrates, could cause the workpiece to be thrown from the Lathe . . . or the turning tool to be jerked from your hands.

c. Always revolve the workpiece by hand before turning on the motor. If the workpiece strikes the tool rest, it could split and be thrown out of the Lathe.

d. Do not allow the turning tool to "bite" into the workpiece which could result in splitting of the workpiece or the workpiece being thrown from the Lathe. Always position the tool rest above the centerline of the Lathe for spindle turning. Do not apply the turning tool to the workpiece below the level of the tool rest.

e. Do not run the Lathe in the wrong direction. This could cause the turning tool to be thrown from your hands. The Lathe must run in a direction so that the workpiece turns toward you.

f. Before attaching a workpiece to the faceplate always "rough it out" to as "true round" as possible. This will minimize vibration while turning.

Always fasten the workpiece securely to the faceplate.

Failure to perform these set-up operations could cause the workpiece to be thrown from the Lathe.

g. Avoid awkward hand positions, where a sudden slip could cause a hand to move into the workpiece.

h. Remove all loose knots before installing workpiece between centers or on the faceplate.

i. Never leave the Lathe work area with the power on before the Lathe has come to a complete stop, or without removing and storing the switch key.

j. Never operate the Lathe with protective cover on the unused shaft end of the motor removed.

7. Hang your turning tools on the wall toward the tailstock end of the Lathe. Do not lay them on the bench so that you must reach over the revolving workpiece to select them.

8. Keep firm hold and control of the turning tool at all times. Special caution must be exercised when knots or voids are exposed to the turning tool.

9. Note the following DANGER label which appears on the front of the belt guard.

DANGER

FOR YOUR OWN SAFETY:

READ AND UNDERSTAND THE OWNER'S MANUAL BEFORE OPERATING MACHINE:

1. WEAR SAFETY GOGGLES PER ANSI Z87.1 AND FACE SHIELD IF OPERATION IS DUSTY.

2. DO NOT WEAR GLOVES, NECKTIES, OR LOOSE CLOTHING. TIE BACK LONG HAIR.

3. BE POSITIVE ALL LOCKS ARE TIGHT BEFORE OPERATING MACHINE.

4. TURN WORKPIECE BY HAND BEFORE APPLYING POWER TO DETERMINE IF IT CLEARS THE TOOL REST OR OTHER MACHINE PARTS.

5. ROUGH OUT FACEPLATE WORKPIECES BEFORE INSTALLING ON FACEPLATE TO AVOID EXCESSIVE VIBRATION AND POSSIBLE INJURY.

6. DO NOT MOUNT SPLIT OR CHECKED WORKPIECE OR ONE CONTAINING KNOT.

7. ALWAYS USE LOWEST SPEED WHEN STARTING A NEW WORKPIECE, USING FACEPLATE OR TURNING BETWEEN CENTERS, TO MINIMIZE POTENTIAL INJURY.

10. Think Safety.

11. Complete hand sanding of between-centers or faceplate mounted workpieces BEFORE removing from the lathe. Do not exceed the speed used for the last cutting operation performed on the workpiece, in accordance with the speed chart.

12. NEVER attempt to remount a faceplate turning to the faceplate for any reason. NEVER attempt to remount a between-centers turning if the original centers in the turning have been altered or removed. BE POSITIVE the lathe is set at the lowest speed if remounting a between-centers turning with non-altered original centers.

13. Use extra caution in mounting a between-centers or spindle turning to the faceplate, or a faceplate turning to between-centers, for subsequent operations. BE POSITIVE the lathe is set at the lowest speed before turning ON.

14. NEVER mount a workpiece that contains any splits, checks, or loose knots to a faceplate or between centers.

15. Do not perform any operation when hand holding the workpiece. Do not mount a reamer, milling cutter, wire wheel, buffing wheel, or a drill bit to the headstock spindle.

16. Use the drill chuck accessory in the tail stock only. Do not mount any drill that extends more than 6 inches beyond chuck jaws.

WARNING: DO NOT ALLOW FAMILIARITY (GAINED FROM FREQUENT USE OF YOUR MACHINE) TO BECOME COMMONPLACE. ALWAYS REMEMBER THAT A CARELESS FRACTION OF A SECOND IS SUFFICIENT TO INFLICT SEVERE INJURY.



The operation of any power tool can result in foreign objects being thrown into the eyes, which can result in severe eye damage. Always wear safety goggles complying with ANSI Z87.1 (shown on Package) before commencing power tool operation. Safety Goggles are available at Sears retail or catalog stores.

WARNING: THE FOUR STEP LATHE AND MOTOR PULLEYS FURNISHED ARE DESIGNED TO RUN THE LATHE AT THE CORRECT SPEEDS WHEN USED WITH A 1725 R.P.M. MOTOR. DO NOT USE A 3450 R.P.M. MOTOR TO INCREASE THE SPEED BECAUSE IT COULD BE DANGEROUS.

CONTENTS

GENERAL SAFETY INSTRUCTIONS FOR POWER TOOLS	2	Spur Center and Cup Center (Aligning Centers)	12
ADDITIONAL SAFETY INSTRUCTIONS FOR WOOD TURNING LATHE	3	Tailstock	12
MOTOR SPECIFICATIONS AND ELECTRICAL REQUIREMENTS	4	Speed Chart	13
UNPACKING AND CHECKING CONTENTS	5	BASIC LATHE OPERATIONS	13
ASSEMBLY	6	Changing Speeds	13
Mounting Lathe and Motor on Workbench	7	Spindle Turning	14
Spur and Cup/Center Installation	9	Indexing	15
On-Off Switch	10	HOW TO USE YOUR CRAFTSMAN WOOD-LATHE	16
Check Motor Rotation	11	Woodworking Chisels and How to Use Them	16
GETTING TO KNOW YOUR WOOD LATHE	11	Making Standard Cuts	20
Belt Guard Lock	11	How to Handle Spindle Turnings	22
Index Pin	11	Miscellaneous Operations	24
Spindle Lock Hole	11	Faceplate and Chuck Turnings	25
Tool Rest Bracket Lock	11	How to Make Fancy Faceplate Turnings	26
Tool Rest Lock	11	How to Turn Plastics	28
Tool Rest Base Lock	11	Sanding, Buffing and Polishing	29
Handwheel	11	MAINTENANCE	30
Tailstock Ram Lock	11	LUBRICATION	30
Tailstock Lock	11	RECOMMENDED ACCESSORIES	31
On-Off Switch	11	TROUBLESHOOTING	31
		REPAIR PARTS	33

motor specifications and electrical requirements

This Lathe is designed to use a 1725 RPM motor only. Do not use any motor that runs faster than 1725 RPM. It is wired for operation on 110-120 volts, 60 Hz., alternating current. IT MUST NOT BE CONVERTED TO OPERATE ON 230 VOLTS. EVEN THOUGH SOME OF THE RECOMMENDED MOTORS ARE DUAL VOLTAGE.

THESE MOTORS HAVE BEEN FOUND TO BE ACCEPTABLE FOR USE ON THIS TOOL.

HP	RPM	VOLTS	CATALOG NO.
1/3	1725	110-120	1282
1/2	1725	110-120	1278
1/2	1725	110-120	1279
1/2	1725	110-120	1289

CAUTION: Do not use blower or washing machine motors or any motor with an automatic reset overload protector as their use may be hazardous.

CONNECTING TO POWER SOURCE OUTLET

This machine must be grounded while in use to protect the operator from electric shock.

Plug power cord into a 110-120V properly grounded type outlet protected by a 15-amp. dual element time delay or Circuit-Saver fuse or circuit breaker.

If you are not sure that your outlet is properly grounded, have it checked by a qualified electrician.

WARNING: DO NOT PERMIT FINGERS TO TOUCH THE TERMINALS OF PLUGS WHEN INSTALLING OR REMOVING THE PLUG TO OR FROM THE OUTLET.

WARNING: IF NOT PROPERLY GROUNDED THIS POWER TOOL CAN INCUR THE POTENTIAL HAZARD OF ELECTRICAL SHOCK. PARTICULARLY WHEN USED IN DAMP LOCATIONS IN PROXIMITY TO PLUMBING. IF AN ELECTRICAL SHOCK OCCURS THERE IS THE POTENTIAL OF A SECONDARY HAZ-

ARD SUCH AS YOUR HANDS CONTACTING THE CUTTING TOOL.

If power cord is worn or cut, or damaged in any way, have it replaced immediately.

If your unit is for use on less than 150 volts it has a plug that looks like below.

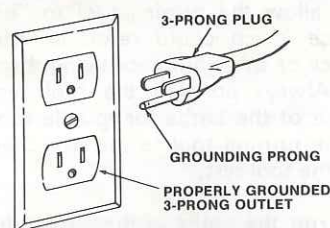

This power tool is equipped with a 3-conductor cord and grounding type plug which has a grounding prong, approved by Underwriters' Laboratories. The ground conductor has a green jacket and is attached to the tool housing at one end and to the ground prong in the attachment plug at the other end.

This plug requires a mating 3-conductor grounded type outlet as shown.

If the outlet you are planning to use for this power tool is of the two prong type DO NOT REMOVE OR ALTER THE GROUNDING PRONG IN ANY MANNER. Use an adapter as shown and always connect the grounding lug to known ground.

It is recommended that you have a qualified electrician replace the TWO prong outlet with a properly grounded THREE prong outlet.

A temporary adapter as shown below is available for connecting plugs to 2-prong receptacles. The green grounding lug extending from the adapter must be connected to a

permanent ground such as to a properly grounded outlet box.

A temporary adapter as illustrated is available for connecting plugs to 2-prong receptacles. The temporary adapter should be used only until a properly grounded outlet can be installed by a qualified electrician.

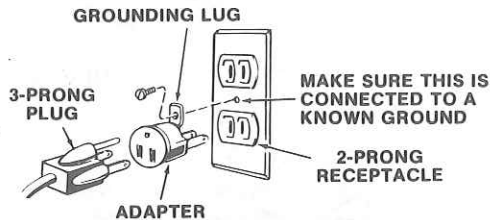

NOTE: The adapter illustrated is for use only if you already have a properly grounded 2-prong receptacle.

The use of any extension cord will cause some loss of power. To keep this to a minimum and to prevent overheating and motor burn-out, use the table below to deter-

mine the minimum wire size (A.W.G.) extension cord. Use only 3 wire extension cords which have 3-prong grounding type plugs and 3-pole receptacles which accept the tools plug.

Extension Cord Length	Wire Size A.W.G.
Up to 100 Ft.	16
100 - 200 Ft.	14
200 - 400 Ft.	10

CHECK MOTOR ROTATION

Place the motor on your workbench or on the floor. Standing clear of the motor shaft, plug the motor cord into a properly grounded outlet. Notice the rotation of the shaft. As you look directly at the motor shaft it should be turning in the clockwise direction . If the motor shaft is turning clockwise, remove the plug from the power outlet and continue the assembly procedures. If the motor is turning counterclockwise, remove the plug from the power outlet and contact your Sears Store immediately.

assembly procedure

UNPACKING AND CHECKING PARTS

PARTS TABLE

A Belt Guard Assembly	1
B Headstock	1
C Motor Pulley	1
D V-Belt	1
E Motor	1
F Large Tool Rest	1
G Tool Rest Holder	1
H Tailstock and Ram	1
J Rear Foot	1
K Clamp Support	1
L Tube Or Bed	1
M Small Tool Rest	1
N Manual	1
O Loose Parts Bag Part No. 507458 (Containing the following items):	
Bolt, Carriage 1/4-20 x 1-3/4	4
Spur Center	1
Point Center	2
Cup Center	1
Cord Clamp	2
Grip	4
Switch Key	1
Lockwasher, Ext. #10	4
Nut, Lock 1/4-20	4
Nut, Hex 1/4-20	4
Nut, Sq. 1/4-20	3
Nut, Hex Heavy 3/4-16	1

TOOLS NEEDED

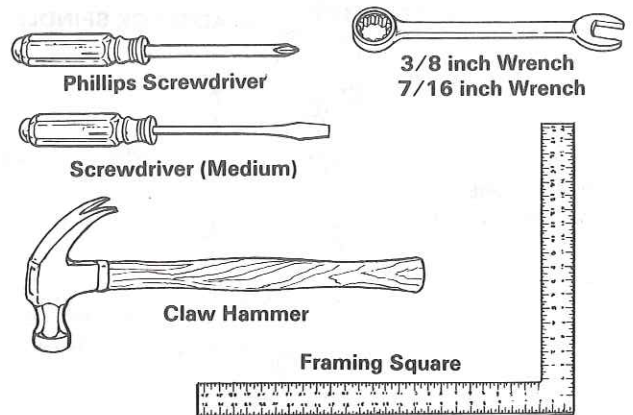

Screw, Pan Hd. Ty T 10-32 x 1/2	4
Screw, Pan Hd. Ty AB #8 x 1/2	4
Shoe, Lock	2
Stud, Nut	4
Washer, 17/64 x 47/64 x 1/16	7
Wrench, Hex "L" 3/16	1
Wrench, Hex "L" 5/32	1
Handle	4

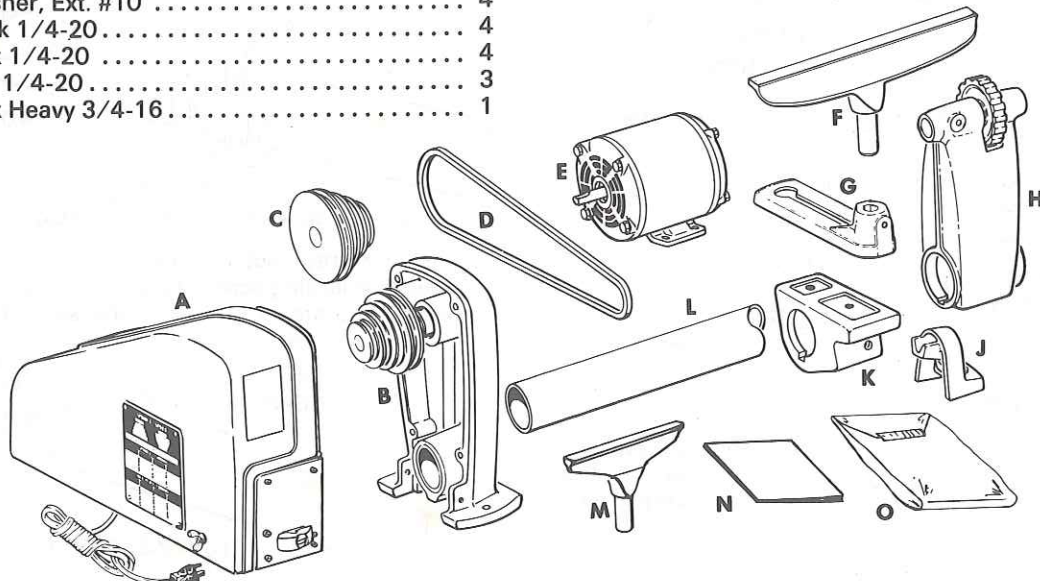

assembly

1. Unpack all the parts of your wood lathe and lay them out in your work area so they can be recognized easily. Check all parts with the parts table and be careful not to lose any parts during assembly.
2. Begin by placing the tube assembly on your workbench as shown. Always keep the squared key section straight down.

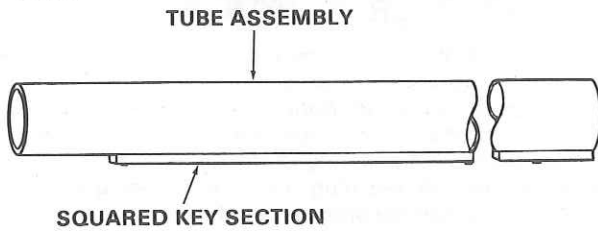

3. Slide the headstock onto the tube until it stops against the squared key section. Insert locking setscrew and tighten with hex wrench.

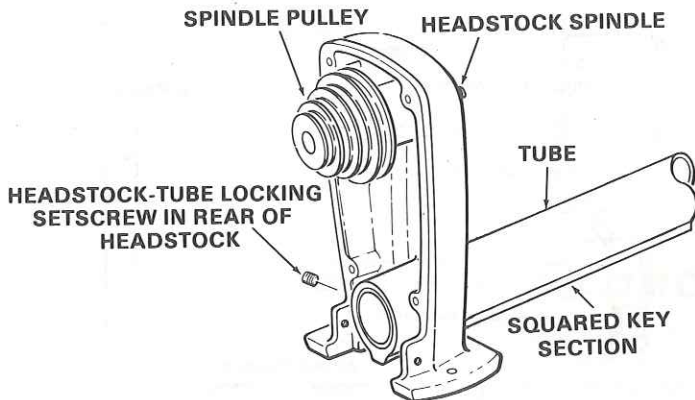

4. Slide the clamp support onto the middle of the tube. Assemble lock handle as shown.

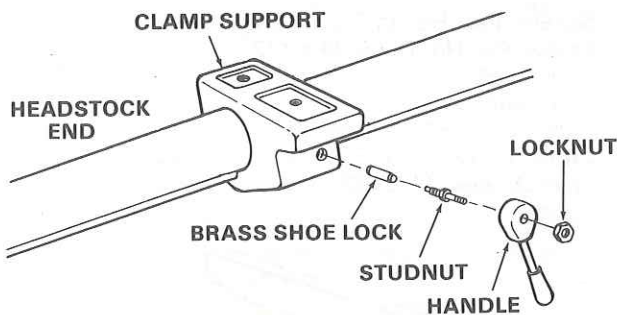

5. Attach the tool rest holder to the clamp support as shown.

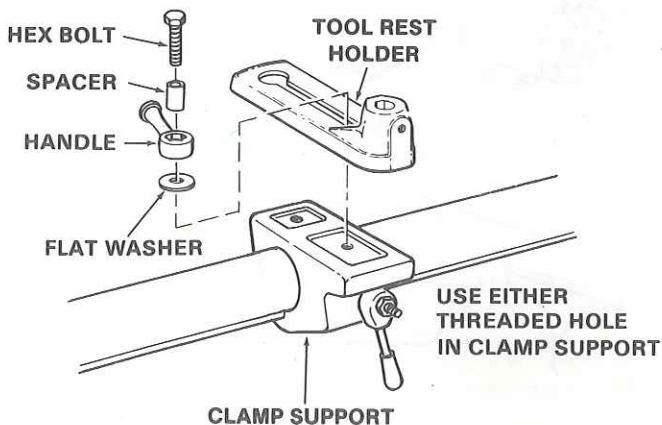

6. Set large tool rest in tool rest holder and install locking handle as shown.

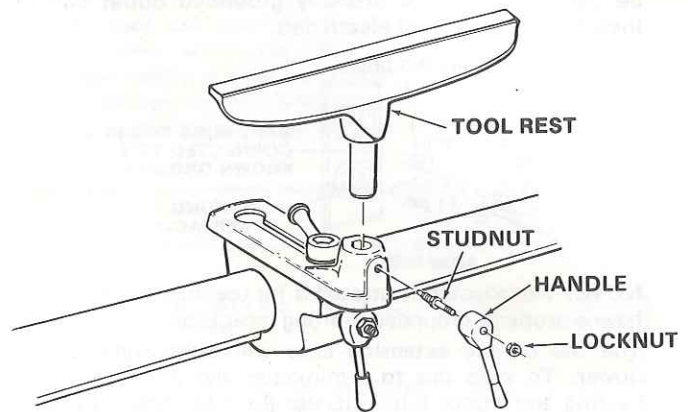

7. Slide tailstock assembly onto the tube and install tailstock ram spindle lock handle. Notice location of keyed way in spindle with studnut.

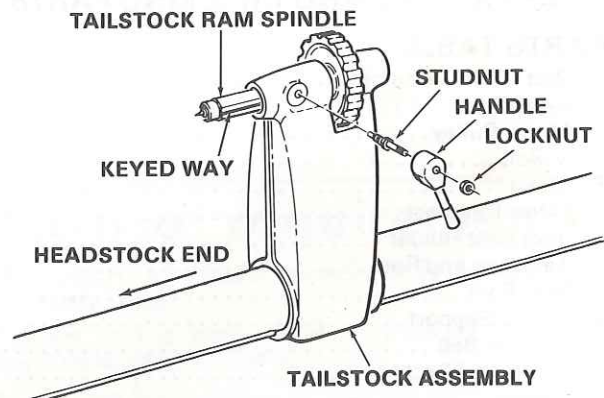

8. On the backside of the tailstock assemble the locking devices as shown.

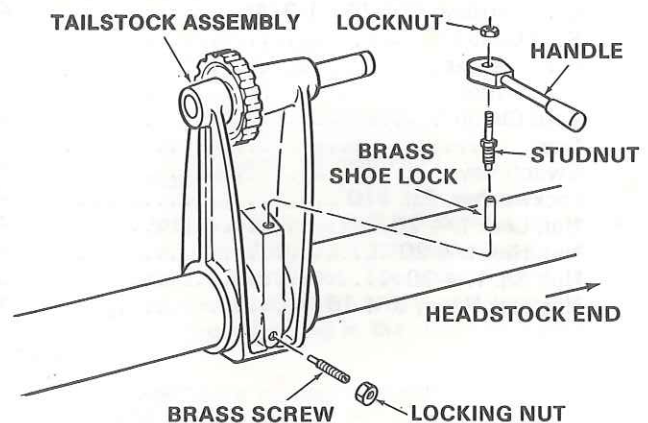

9. Install the rear foot onto the tube as shown and tighten rear foot locking screw. Foot will wedge into place as screw is tightened. This may take several attempts.

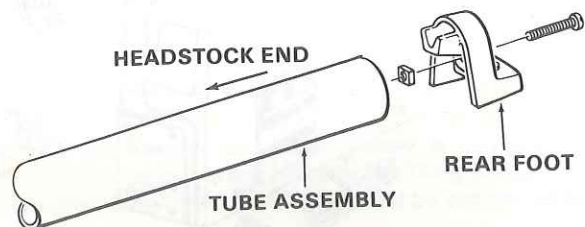

MOUNTING YOUR LATHE AND MOTOR ON A WORKBENCH

SPECIAL NOTE: For best results when mounting your lathe and motor to a workbench, lay them both on your bench in the position which will best suit your needs. Be sure the motor and lathe are in a parallel position and then mark the mounting hole positions. Or, use the diagram shown.

1. Workbench for mounting Lathe must be at least 54-in. long. Drill six $\frac{3}{8}$ " holes in your bench according to the diagram. **NOTE: Make sure the top of your bench is positioned so that you don't drill into the legs or rail underneath and you have access underneath to mount the nuts for lathe and motor bolts.**

When mounting to a Sears workbench, side overhang of top at headstock end should be 5" from leg portion of stand. (Front overhang of top should remain 1- $\frac{1}{8}$ ").

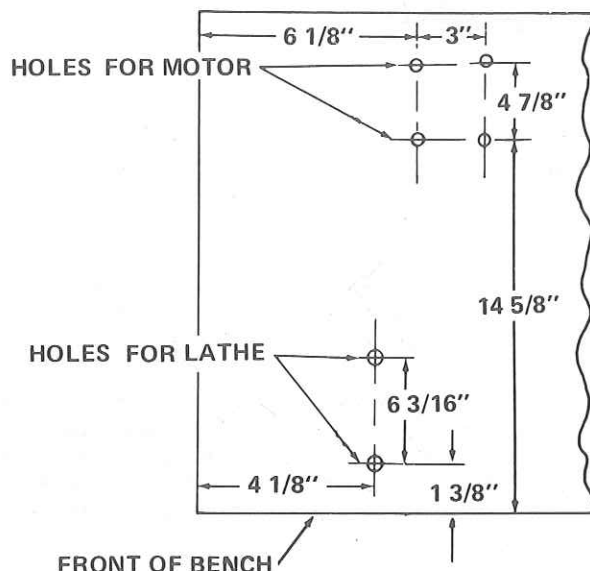

LOCATION OF MOUNTING HOLES

2. Position Lathe on bench and insert two bolts through holes in headstock but do not screw on the nuts.
3. Position the Lathe so that the bed is parallel to the front of the bench. Check the foot. If the bottom of the foot is not flat on the surface of the bench, loosen the screw in the foot, tap the screw to loosen the locknut inside. Turn the foot so it is flat on the bench and tighten the screw.
4. Mark the location on the bench of the hole in foot.
5. Remove the Lathe and drill a $\frac{3}{8}$ " hole to attach the foot.
6. Position the Lathe and insert the bolts from the top. Place a flat washer, lockwasher and a nut on the bolts and tighten the nuts.
7. Position the motor over the mounting holes.
8. Insert the bolts from the top. Place a flat washer and a nut on the bolts but do not tighten the nuts at this time.

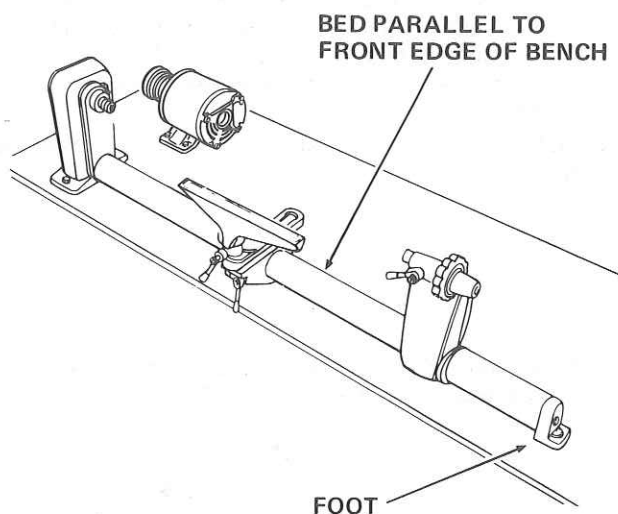

9. Remove the headstock pulley using the $\frac{5}{32}$ " setscrew wrench.
10. Find four pan head thread cutting screws $\frac{1}{2}$ " long and four lockwashers from among the loose parts. Attach the belt guard with these screws and lockwashers. The arrows in this illustration show the location of the screws.

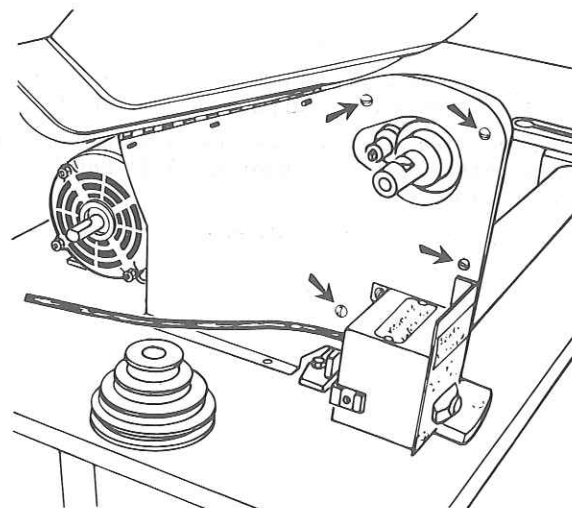
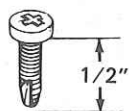

assembly

11. Place the headstock pulley onto the headstock shaft as shown. Position it so that the end of the pulley is flush with the end of the lathe spindle. Tighten the pulley screw against the flat of the shaft.
12. Place the motor pulley on the motor shaft so that the small diameter is approximately $1/16''$ away from the motor. Tighten the setscrew with a $5/32''$ setscrew wrench securely against the flat spot on the motor shaft.
13. Place the belt on the pulleys and slide the motor toward the rear of workbench until all the slack is removed from the belt. **NOTE:** $1/2$ inch deflection of belt under moderate pressure applied between the two pulleys is adequate tension. Tighten only two of the motor mounting bolts.

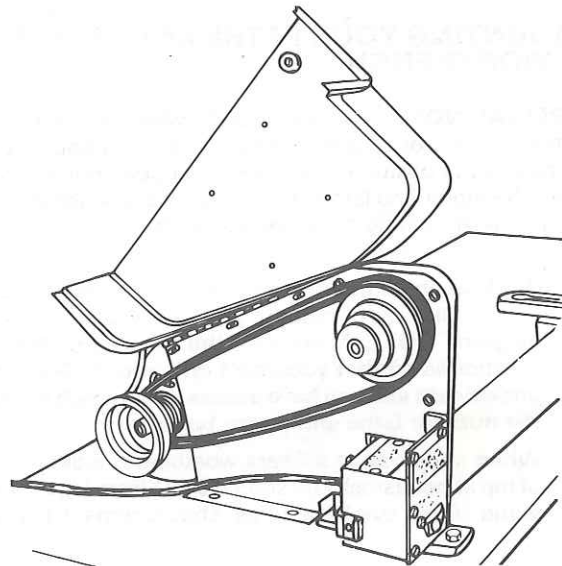

14. Place a straightedge such as a piece of wood, metal or framing square across the pulleys to see if they are in line with each other. If they are, tighten the other two motor mounting bolts. If they are not in line, loosen the two motor bolts and move the motor sideways . . . tighten the bolts.
15. Find four pan head wood screws $1/2''$ long from among the loose parts.

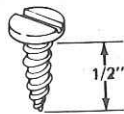

16. Attach the belt guard plate to the bench with the two screws. Make sure the plate is PARALLEL to the belt.

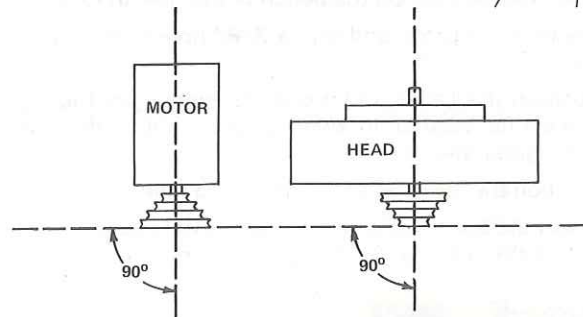
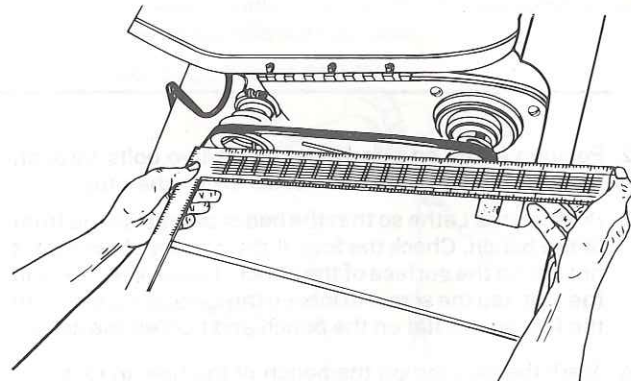

17. Plug motor cord into outlet on back of switch box. **DO NOT** plug motor cord into power source outlet.
18. Position the two cords as shown and clamp them to the table with two cable clamps and $1/2''$ wood screws from the loose parts bag.
19. Coil up the slack in the cord and tie it with a piece of tape if necessary.

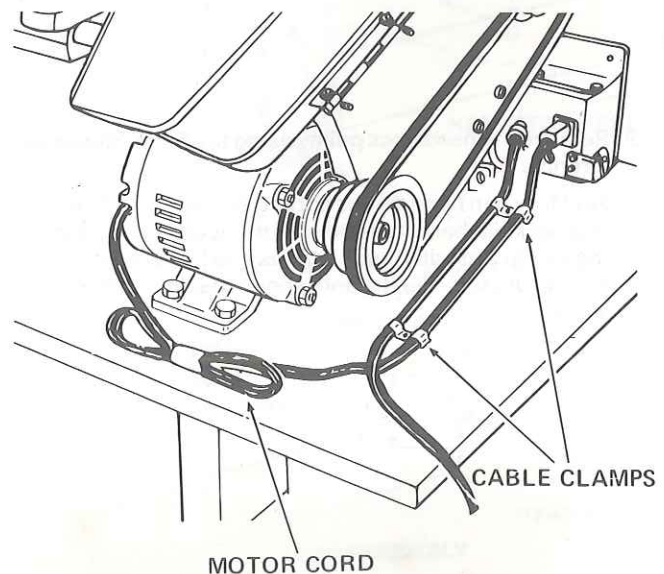

SPUR AND CUP/CENTER INSTALLATION

1. Find a 3/4-16 hex nut among the loose parts and screw onto head stock spindle until finger tight.

3/4-16
HEX NUT

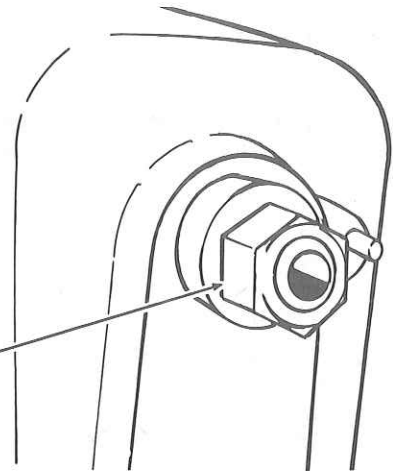

2. Find two points and a spur and cup center among the loose parts. To insert point into centers, place center between jaws of a vise. Do not tighten vise. Insert point into center and with a hammer and nail gently tap around the base of the point until secure.

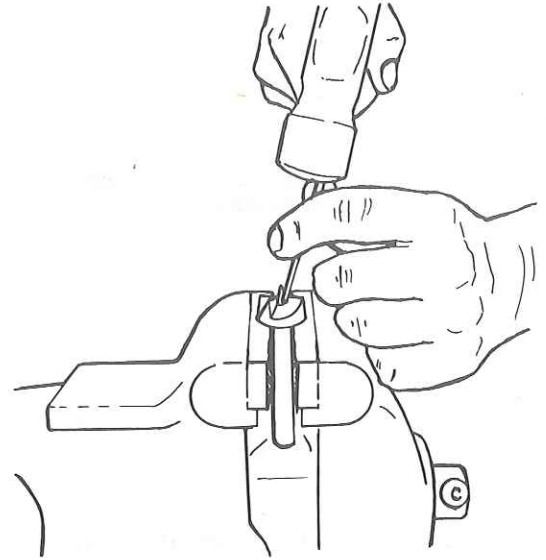

3. Insert spur center into head stock spindle and cup center into tailstock ram. **NOTE:** Do not drive or hammer centers into spindle or ram as removal may be difficult. Use a soft hammer or block of wood and give them a gentle tap.
4. To remove spur center from spindle, hold the spindle pulley with one hand, and, using a wrench or pair of pliers, turn the hex nut counterclockwise until center is ejected.
5. To remove cup center insert a 1/4" wood dowel or brass rod through the hole in the tailstock ram. Hold the center with one hand and tap the dowel or rod with a hammer.

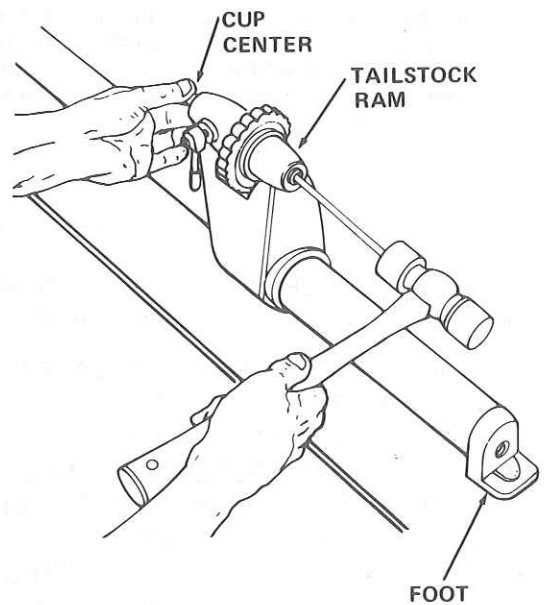

assembly

WARNING: DON'T CONNECT POWER CORD TO ELECTRICAL OUTLET IN YOUR SHOP UNTIL YOU ARE SURE THAT MOTOR ROTATION IS CORRECT (SEE PAGE 5).

ON-OFF SWITCH

The On-Off Switch has a locking feature. THIS FEATURE IS INTENDED TO PREVENT UNAUTHORIZED AND POSSIBLE HAZARDOUS USE BY CHILDREN AND OTHERS.

1. Insert key into switch.

NOTE: Key is made of yellow plastic.

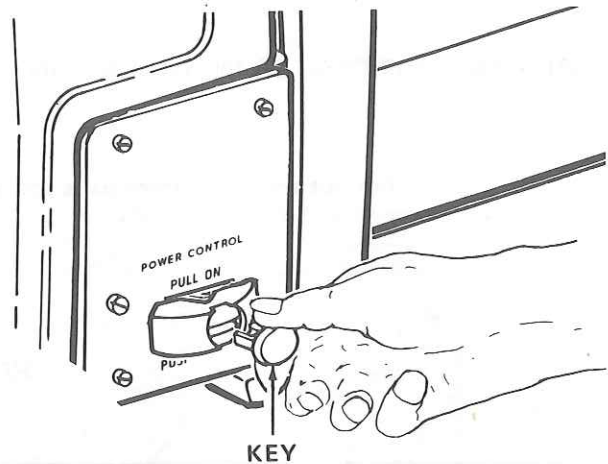

2. To turn Lathe ON . . . INSERT finger under switch lever and pull END of switch out.

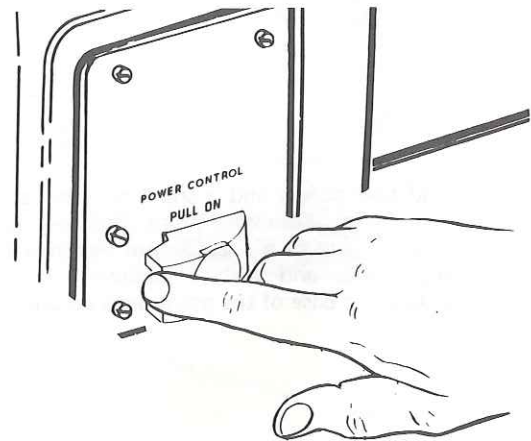

3. To turn Lathe OFF . . . PUSH lever in.

Never leave the Lathe unattended until it has come to a complete stop and you have removed the switch key.

Do not cycle the motor switch on and off rapidly, as this may cause the faceplate or sanding disc to loosen. In the event this should ever occur, stand clear of the face plate or sanding disc until it has come to a complete stop . . . retighten it.

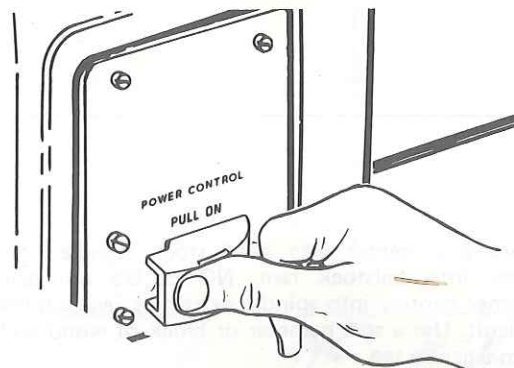

4. To lock switch in OFF position . . . HOLD switch IN with one hand, REMOVE key with other hand.

WARNING: FOR YOUR OWN SAFETY, ALWAYS LOCK THE SWITCH "OFF". WHEN LATHE IS NOT IN USE . . . REMOVE KEY AND KEEP IT IN A SAFE PLACE . . . ALSO . . . IN THE EVENT OF A POWER FAILURE (ALL OF YOUR LIGHTS GO OUT) TURN SWITCH OFF... LOCK IT AND REMOVE THE KEY. THIS WILL PREVENT THE LATHE FROM STARTING UP AGAIN WHEN THE POWER COMES BACK ON.

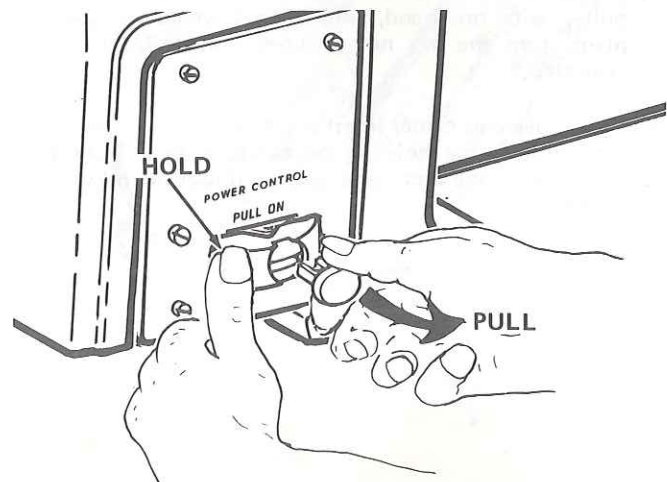

CHECK SPINDLE ROTATION

The Lathe spindle must rotate counterclockwise when viewed from the spindle end.

NOTE: Make sure the spur center is removed from the spindle.

1. Plug the Lathe power cord into a properly grounded outlet (See page 5)
2. Stand clear of the Lathe spindle and turn the switch ON. Notice the rotation of the spindle. If it is NOT turning COUNTERCLOCKWISE contact your Sears Store immediately before using this tool.

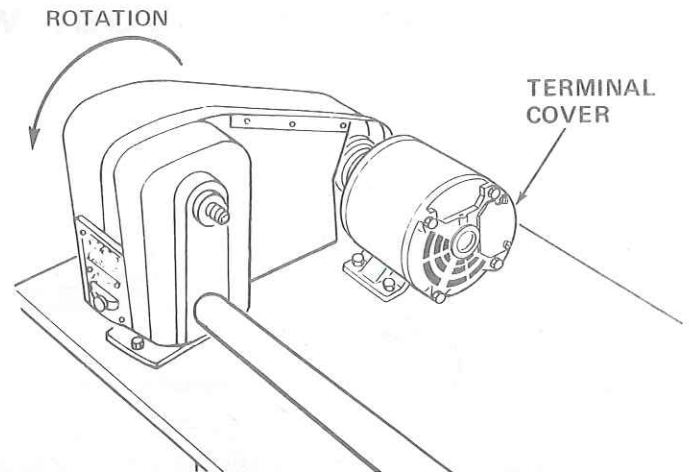

getting to know your wood lathe

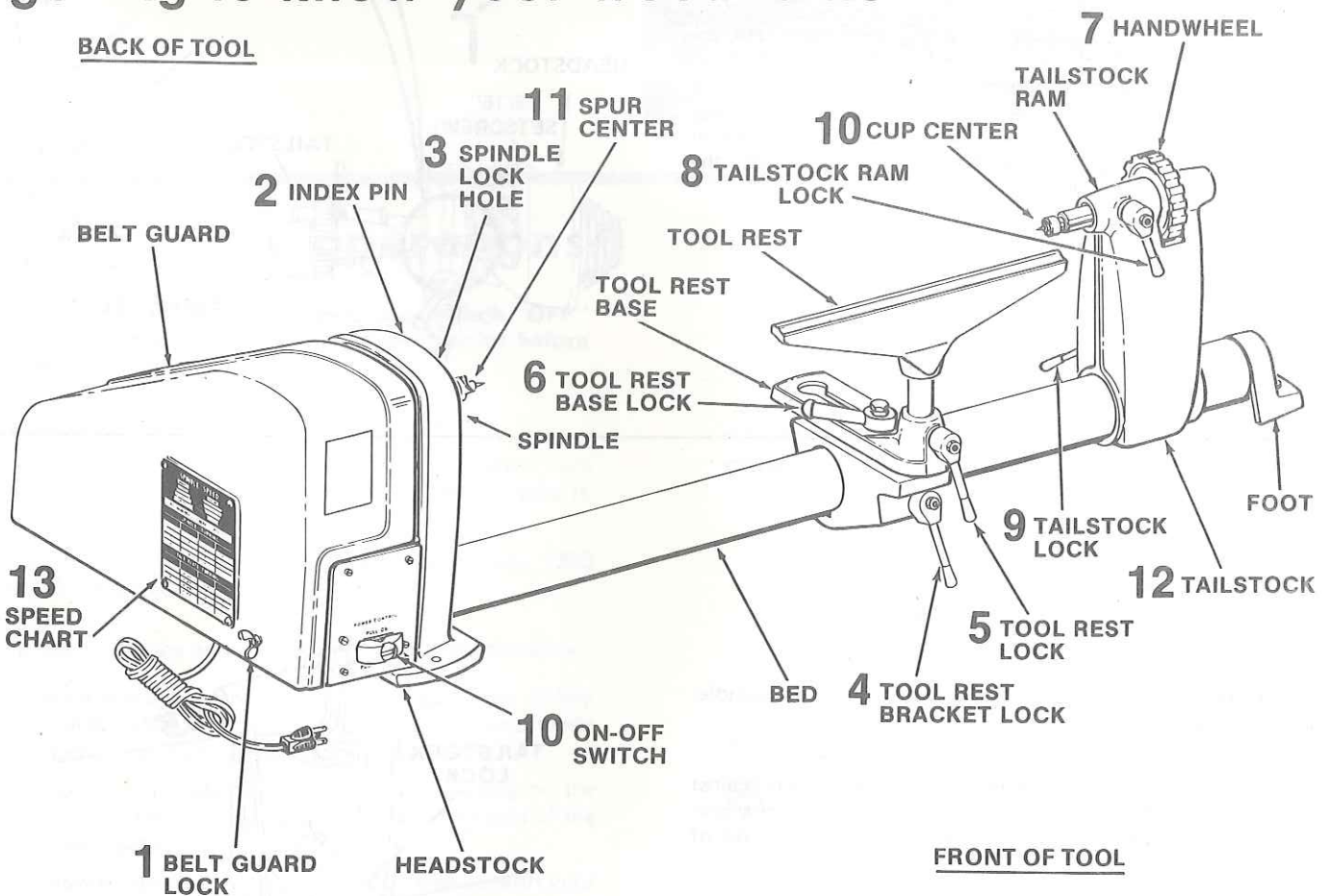

- 1. BELT GUARD LOCK** ... Locks the hinged part of the guard during operation.
- 2. INDEX PIN** ... Engages with the spindle pulley to determine equal spacing for cuts for fluting or reeding, or for dividing face plate work. **DO NOT USE FOR REMOVING FACEPLATES.**
- 3. SPINDLE LOCK HOLE** ... For removing faceplates or sanding discs. Insert a setscrew wrench, large nail or bolt in the hole to hold the spindle while unscrewing faceplate or sanding disc.
- 4. TOOL REST BRACKET LOCK** ... Clamps the tool rest bracket to the bed.

- 5. TOOL REST LOCK** ... Clamp the tool rest to the tool rest base.
- 6. TOOL REST BASE LOCK** ... Clamps the tool rest base to the bed.
- 7. HANDWHEEL** ... Adjusts the tailstock ram.
- 8. TAILSTOCK RAM LOCK** ... Clamps the ram in the tailstock.
- 9. TAILSTOCK LOCK** ... Clamps the tailstock to the bed.
- 10. ON-OFF SWITCH**

getting to know your wood lathe

11. SPUR CENTER AND CUP CENTER . . . are used for spindle turning and should always be in alignment.

ALIGNING CENTERS

If the centers are not in line as shown, make the following adjustments.

1. Make sure the tailstock and ram are locked when checking for alignment.
2. Loosen the screw in the foot . . . TAP the screw to loosen the locknut inside.
3. Using a 3/16" setscrew wrench, loosen the setscrew on the back of the headstock. The screw is located about 1-3/4" from the bottom.
4. Swing the tailstock so that the two points are in line . . . tighten the setscrew in the headstock and the screw in the end of the tailstock.

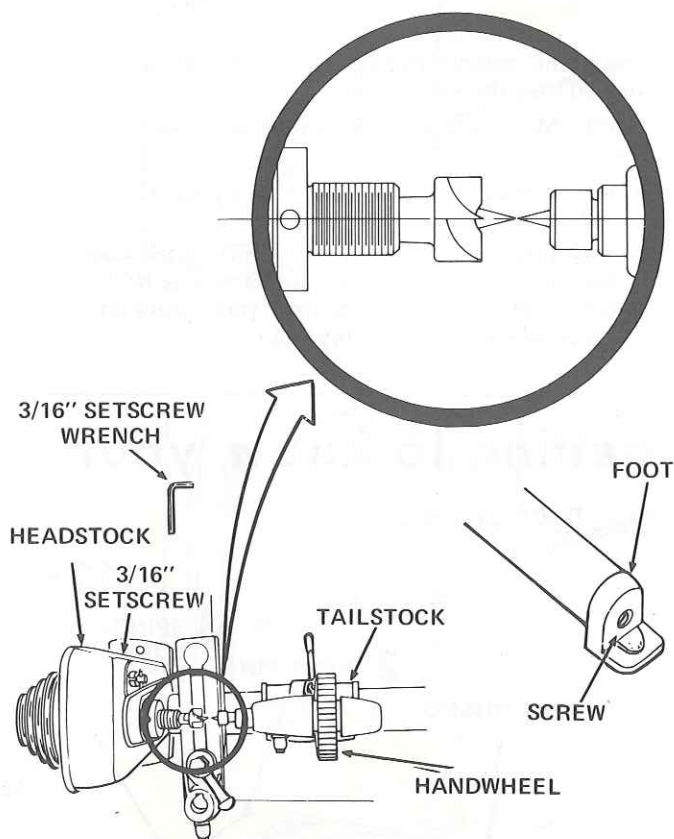

12. TAILSTOCK . . . supports the workpiece for spindle turning.

The tailstock contains a brass screw which bears against the "key" on the underside of the bed. This screw prevents excessive "looseness" (rocking back and forth) of the tailstock.

1. Loosen the locknut using a 7/16" wrench.
2. Tighten the screw moderately against the key, then loosen it about 1/4 turn.

Slide the tailstock along the bed. If it does not stick or bind in any one spot, tighten the nut. If it binds or sticks, loosen the screw only enough so that the tailstock slides smoothly along the bed.

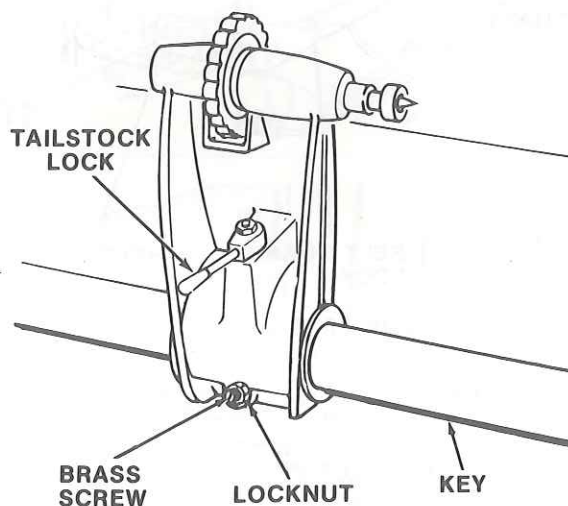

13. SPEED CHART ... Indicates general recommended speeds for various sizes of workpieces.

WARNING: Always use lowest speed when starting a new workpiece, using faceplate, or turning between centers to avoid possible injury.

SPINDLE SPEED

MOTOR	SPINDLE
[Step 1]	875
[Step 2]	1350
[Step 3]	2250
[Step 4]	3450

RECOMMENDED GENERAL SPEEDS

SPINDLE TURNING

SQUARE	LENGTH	ROUGHING	FINISHING
1"	12"	1350	3450
2"	18"	875	2250
3"	27"	875	2250
4"	36"	875	2250

FACE PLATE TURNING

DIAMETER	THICKNESS	ROUGHING	FINISHING
12"	4" MAX	875	1350
10"	4" MAX	1350	2250
8"	4" MAX	1350	2250
6"	4" MAX	2250	3450

MAXIMUM MOTOR SIZE 1/2 H.P. 1725 R.P.M.
(SEE OWNER'S MANUAL)

PAT. 3,618,409

basic lathe operations

WARNING: For your own safety, turn switch "OFF" and remove plug from power source outlet before making any adjustments.

CHANGING SPEEDS

The belt is shown positioned on the second steps from the outside end of the pulleys. This causes the lathe to run 2250 R.P.M.

Suppose you wish to run the lathe slower - say, 1350 R.P.M. You must shift the belt inward.

1. Make sure the power cord is removed from the outlet.
2. With the belt guard raised, rotate the motor pulley **COUNTERCLOCKWISE** with your left hand while pushing on the belt with your right hand.
3. Continue to rotate the pulley while pushing on the belt until it "climbs" down into the third step of the motor pulley.
4. Now rotate the spindle pulley **CLOCKWISE** with your right hand while pushing on the belt with your left hand. The belt will climb up into the third step of the spindle pulley.

To make the lathe go faster, the belt must be shifted outward.

1. Rotate the spindle pulley **CLOCKWISE** with your right hand. Pull on the belt while rotating the pulley until it climbs down into the next smaller step.
2. Now rotate the motor pulley **COUNTERCLOCKWISE** with your left hand while pulling on the belt with your right hand. The belt will climb up into the next larger step.

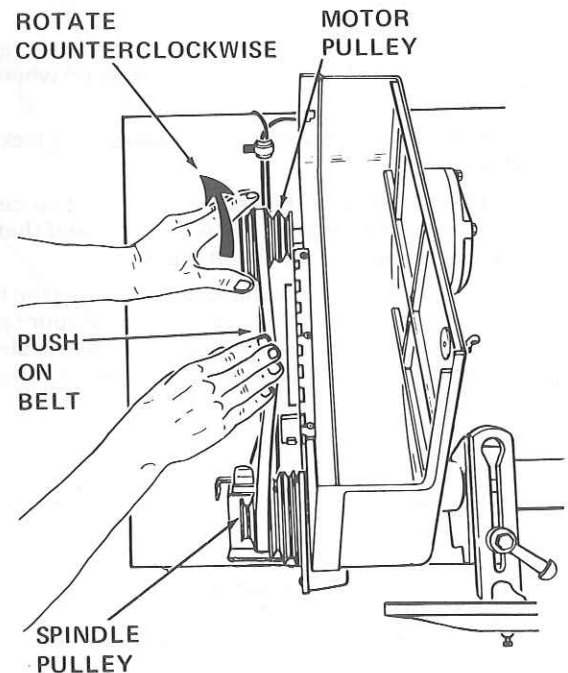

basic lathe operations

SPINDLE TURNING

WARNING: For your own safety, turn switch "OFF" and remove switch key before mounting workpiece in Lathe.

If you have never done any amount of wood turning, we suggest that you practice using the various wood turning tools. Start with a small spindle turning.

Be sure to study the "HOW TO" section of this manual. It explains and illustrates the correct use of the turnings tools, the positioning of the tool rest and other information to help you gain experience.

1. Carefully inspect and select a piece of wood 2" x 2" x 12" and always use wood free of checks, splits, cracks or knots.
2. Draw diagonal lines on each end to locate the centers.
3. On one end, make a saw cut approximately 1/16" deep on each diagonal line. This is for the spur center.
4. The other end is for the cup center. Place the point of the cut center on the wood where the diagonal lines cross.

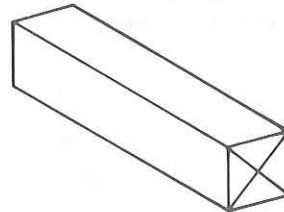

DIAGONAL LINES
ON BOTH ENDS

5. Drive the cup center into the wood. Use a wooden mallet or a plastic hammer. If you don't have one, use a steel hammer, but put a piece of wood on the end of the cup center to protect it.
6. Remove the cup center and drive the spur center into the other end of the wood. Make sure the spurs are in the saw cuts. Remove the spur center.
7. Make sure the centers and the hole in the spindle and the tailstock ram are clean. Insert the spur center into the headstock and the cup center into the tailstock and tap them in lightly with a piece of wood. Do not drive them in.
8. Put a drop of oil or wax on the wood where it contacts the cup center. This will lubricate the wood while it is turning.
9. Place the wood between the centers and lock the tailstock.

WARNING: Be sure the spur center and cup center are firmly seated against the workpiece and that the tailstock is securely locked in place.

10. Move the cup center into the wood by turning the hand wheel. Make sure that the cup center and spur center are "seated" into the wood in the holes made in steps 5 and 6 above. Rotate the wood by hand while turning the hand wheel.

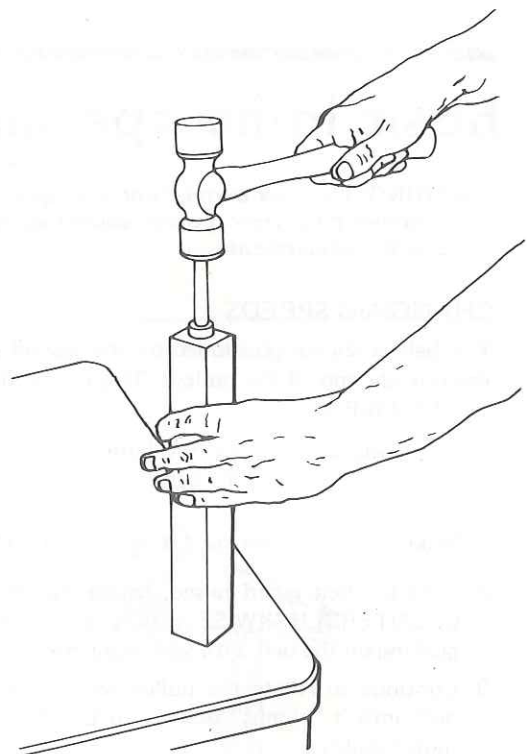

11. Adjust the tool rest approximately 1/8" away from the corners of the wood and 1/8" above the center line. Note the angled position of the tool rest base.

WARNING: For your own safety, after adjusting the tool rest be sure and lock the tool rest base and the tool rest.

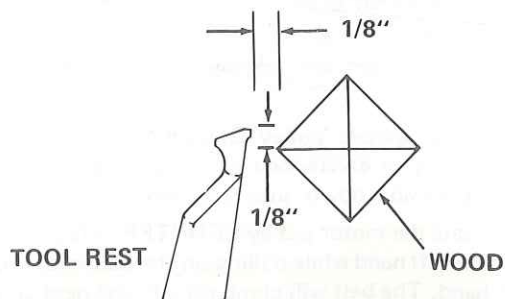

Look at the speed chart. Notice that a 2" square turning up to 18" long should run at 875 R.P.M. for "roughing". Move the V-belt on the pulleys to the slowest speed as outlined under "Changing Speeds" section.

WARNING: For your own safety rotate the wood by hand to make sure that the corners do not strike the tool rest or anything else before turning the Lathe "ON". Always be sure the workpiece is properly mounted and the Lathe is set at the proper speed (RPM).

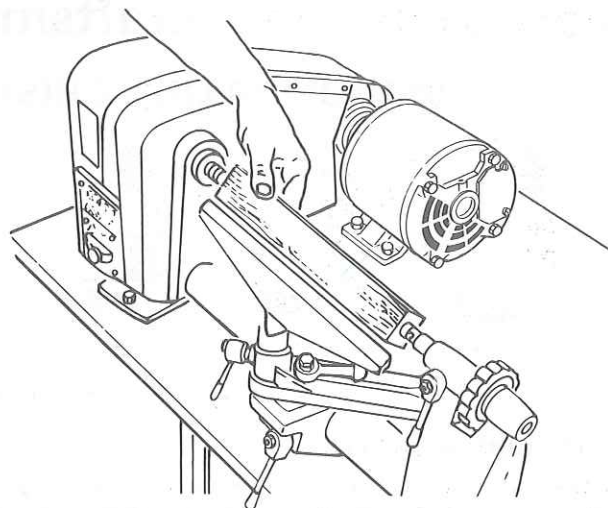

INDEXING

The spindle pulley contains 36 equally spaced holes. The index pin engages with these holes to keep the spindle from turning while you put a mark on the workpiece.

For example: To locate the position of six spokes in a wheel:

1. Pull the index pin outward and turn it so that the small cross pin slips into the slot. This will allow the index pin to engage in one of the holes in the pulley and prevent the spindle from turning.
2. Adjust the tool rest approximately at the centerline and make a mark.
3. Pull out the index pin and slowly rotate the workpiece until the pin slides into the next hole in the pulley.
4. Do this six times and put the next mark on the workpiece. The two marks will be spaced 60° apart. Continue this operation until six spokes are marked 60° apart.
5. Spindle turnings can be divided in the same manner.

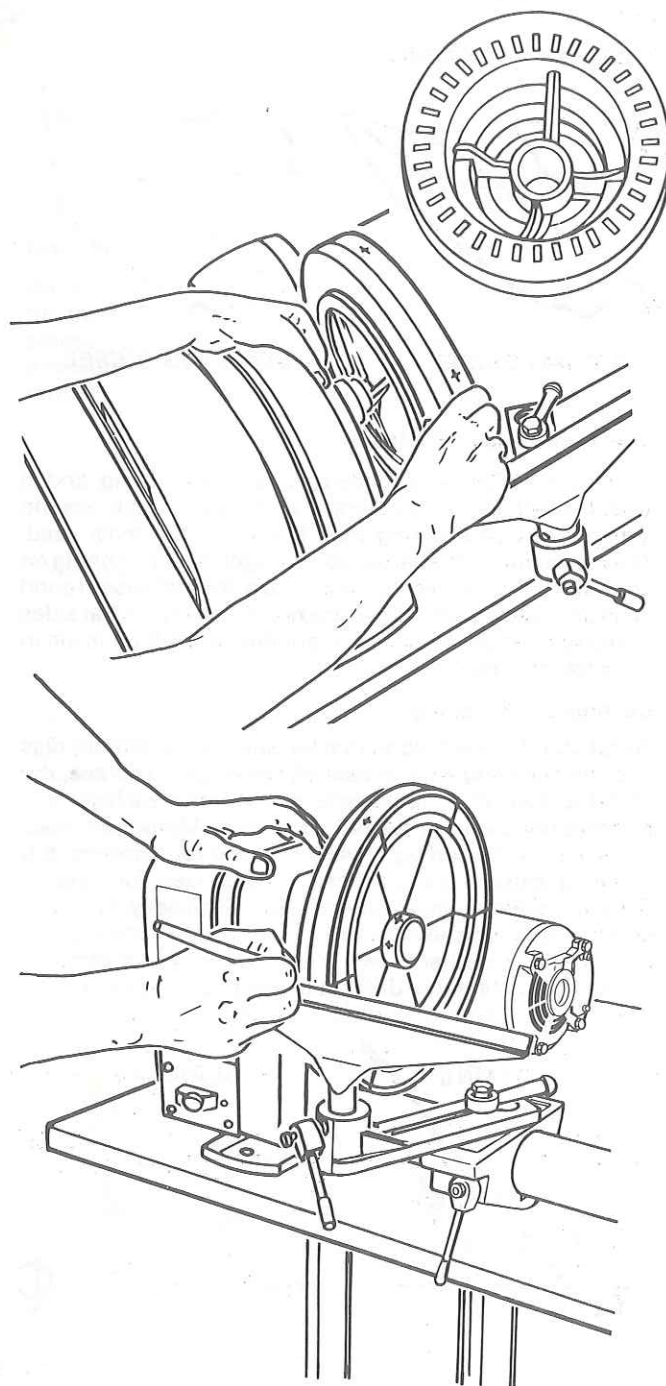

how to use your craftsman wood-lathe

WOODWORKING CHISELS AND HOW TO USE THEM

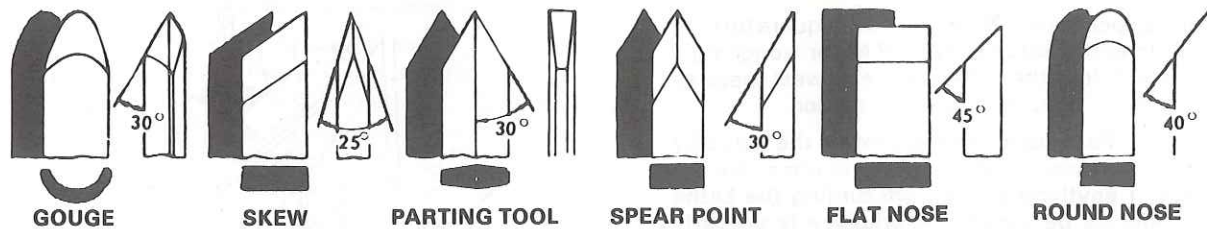

THE SIX COMMONLY USED CHISEL TYPES

SELECTION OF CHISELS

Better chisels have handles approximately 10-in. long, to provide plenty of grip and leverage. Sharp tools are essential for clean, easy work . . . buy tools that will take and hold keen edges.

THEORY OF TURNING

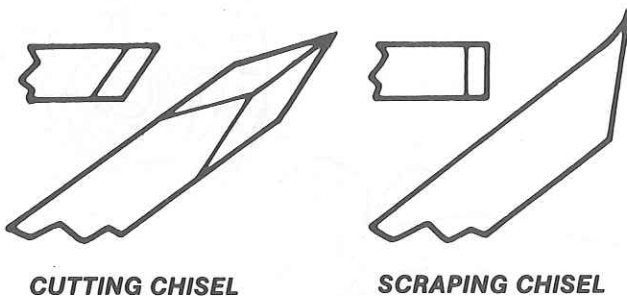

The Two Classes of Chisels

These are: 1) Chisels intended primarily for cutting, and 2) chisels used only for scraping. The cutting chisels are the gouge, skew and parting tool. These are the most used. They are commonly sharpened to a razor edge by honing on both sides. The scraping chisels are the flatnose, round nose and spear point. These are not honed on the flat sides — the wire edges produced by grinding are left on to aid in the scraping process.

Cutting and Scraping

To cut, the chisel is held so that the sharp edge actually digs into the revolving work to peel off shavings. To scrape, the chisel is held at a right angle to the work surface, and removes fine particles instead of shavings. Many operations require that the cutting chisels be used for scraping; but scraping chisels are practically never used for cutting. Scraping dulls a chisel much faster, especially the razor sharp cutting chisels. Cutting is faster than scraping and produces a smoother finish which requires less sanding. However, it is far more difficult to master. Scraping, on the other hand, is far more precise and easier to control.

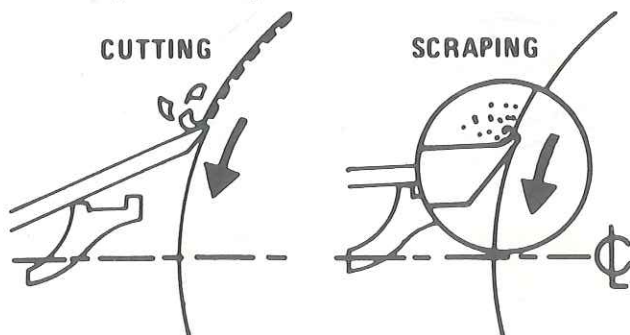

When You Can Cut, and When You Must Scrape

There are two different approaches to the work when turning. One approach is toward a circumference of the workpiece (for example, turning down the outer surface of a cylinder or the inner wall of a hollow round box.) In this approach, the surface being turned travels under the chisel edge like an endless belt. The second approach is toward the diameter of a workpiece (as when turning the face of a faceplate turning, or the side of a large shoulder on a spindle turning). In this approach the surface being turned rotates like a disc under the chisel edge. Sometimes the approach will be a combination of both.

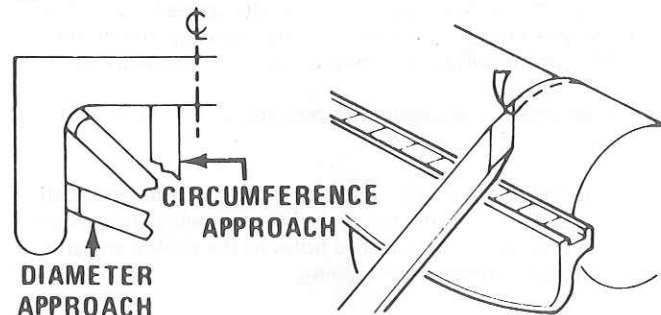

Either a cutting or scraping action can be used when the approach is toward a circumference — the shaving is removed like a peeling from a potato. Scraping, only, can be used when the approach is toward a diameter. The reason is obvious when you consider that faceplate turning practically always requires removal of wood across the grain. Wood does not peel easily across the grain, and attempts to use cutting methods will likely result in damage to the work and throwing of the chisel by the work.

It follows that a cutting action is used for the general run of spindle turning operations . . . while the major part of a faceplate turning is done by the scraping method. When a combination approach is to be used, you will have to judge, by the feel of the work, when to stop cutting and start scraping. *Never* try to cut when it becomes difficult to hold the chisel against the roughness of the wood grain.

How to Position Tool Rest for Circumference Cutting

When cutting, the object is to pierce the outer skin of wood to a certain desired depth, then to hold the chisel steady, with the bevel edge parallel to the work circumference, so that it will peel off a shaving at this desired depth. The only sure method of holding the chisel steady is to rest the bevel against the work, as shown in sketch 1. When the tool rest is at the proper height (sketch 1), the chisel can be held with the bevel pressed against the work, and the tool rest will act as a fulcrum to support the chisel against the downward force of the revolving work.

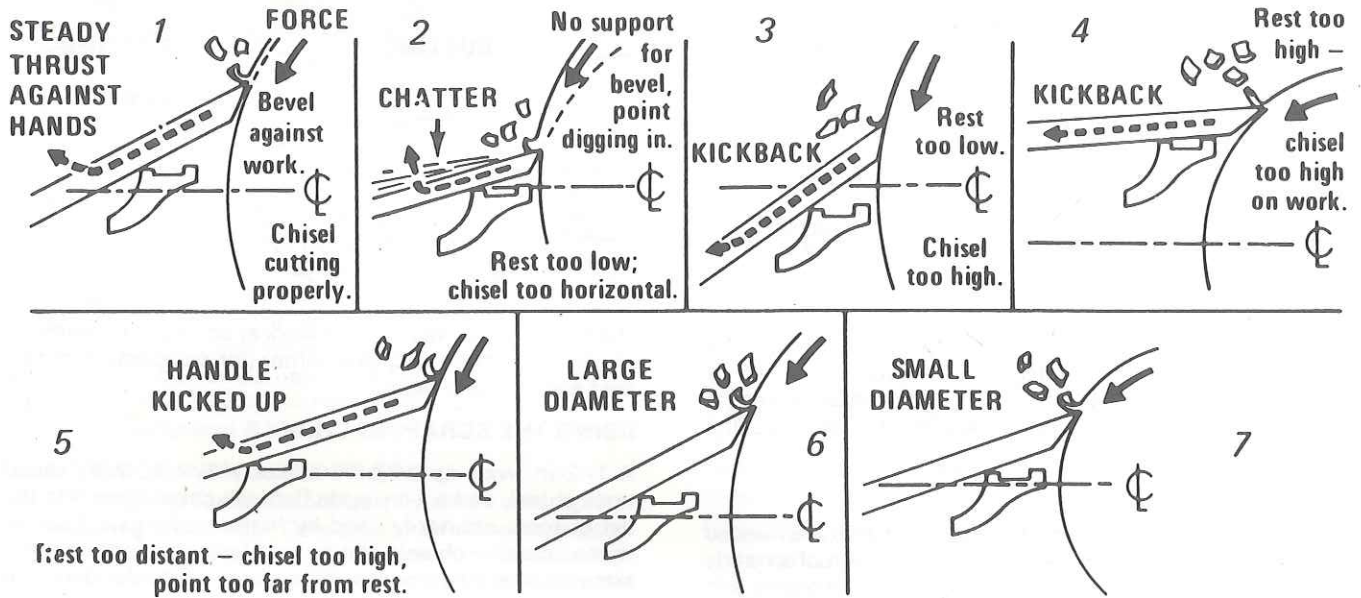

If the rest is placed too low, so that the chisel is held with the bevel out from the work (sketch 2), the cutting edge will continue to dig deeper into the work. It will dig in until the "bite" becomes so deep that your hands have difficulty holding the chisel — then the improperly supported chisel will begin to bounce, or chatter, against the workpiece.

If the rest is placed too low, the chisel must be held extremely high to position the bevel against the work (sketch 3). Then the rest loses most of its value as a fulcrum, and the downward force of the revolving workpiece tends to kick the chisel back out of your hands.

If the rest is placed too high (sketch 4) and the chisel is correctly positioned for cutting, it strikes the workpiece near the top where the direction of force exerted by the workpiece is nearly horizontal — and kickback will again result.

If the rest is placed too far out from the work surface (sketch 5) — then, when correctly held, the chisel is again too high on the work. Also, you have less leverage on your side of the tool rest — and it is even more difficult to hold the chisel. With large diameter work (sketch 6), the tool rest can be above the workpiece centerline, and somewhat out from the work surface. With small diameter work (sketch 7), the rest should be lowered almost to the centerline, and should not be far from the work surface. As work grows smaller, the rest should be repositioned.

How to Position Tool Rest for Circumference Scraping

In scraping operations, the tool rest position is not as critical as it is for cutting operations. The chisel generally is held horizontally, though it can be held at an angle to reach into tight places. Considering that the wire edge of the chisel

does the scraping, sketches 9 and 10 show the results of too low or too high a position for the rest; and sketch 8 shows the chisel action with the rest correctly positioned.

How to Position Chisel and Rest for Diameter Scraping

When scraping on the diameter, that portion of surface to the right of center is moving upward (sketch 11). If chisel is placed in this area, it will simply be carried up off the rest and out of your hands. All diameter approach operations must be done at the *left* of center.

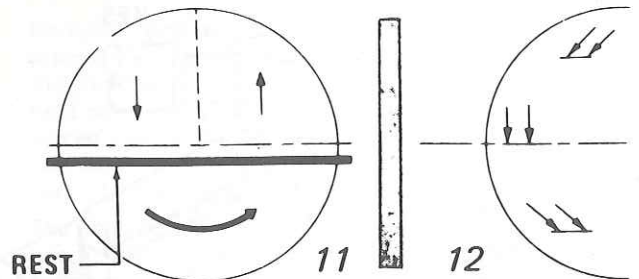

Three different chisel contact points are shown in sketch 12. It will be noted that, when chisel is above the workpiece center, or below it, the work surface sweeps past the chisel edge at an angle and tends to carry the chisel in one direction or the other along the rest. Only when the chisel contacts the work on the centerline does the work surface pass squarely under the chisel edge. This, then, is the position in which it is easiest to hold the chisel steady. To obtain this position, place the rest approximately 1/8-inch (thickness of chisel) below center.

USING THE GOUGE

Three gouges, the 1/4-, 1/2- and 3/4-in. sizes, are ample for general homeshop turning; but other sizes from 1/8- to 2-in. can be purchased.

The chief use of the gouge is for rough circumference cutting of raw stock down to a cylinder of working size. It is the best tool to use for rapid cutting away of large areas of the workpiece; but when so used does not produce a smooth surface. With practice, it can be used for cutting coves and the shaping of long cuts — is also useful for scraping.

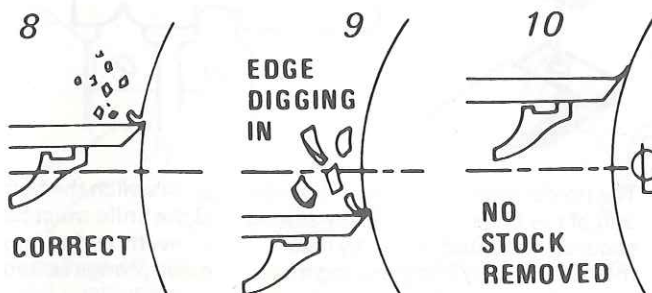

how to use your craftsman wood-lathe

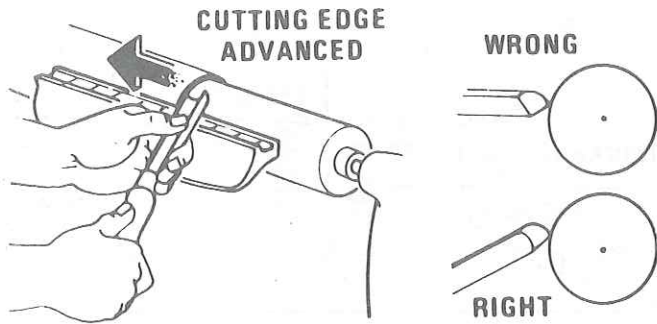

When used for cutting, the gouge is always held with the convex side down. It should be rolled approximately 30° to 45° in the direction in which it is being advanced along the rest; and the cutting edge should be a little in advance of the handle.

USING THE SKEW

Two skews, the 1/2- and 1-in. sizes, are all that are needed for general use. Other sizes are available. This tool is nearly always used to make finish cuts, to cut vees and beads, and to square shoulders. Properly used, it produces the best finish that can be obtained with a chisel. It should be used but little for scraping, as this quickly dulls it.

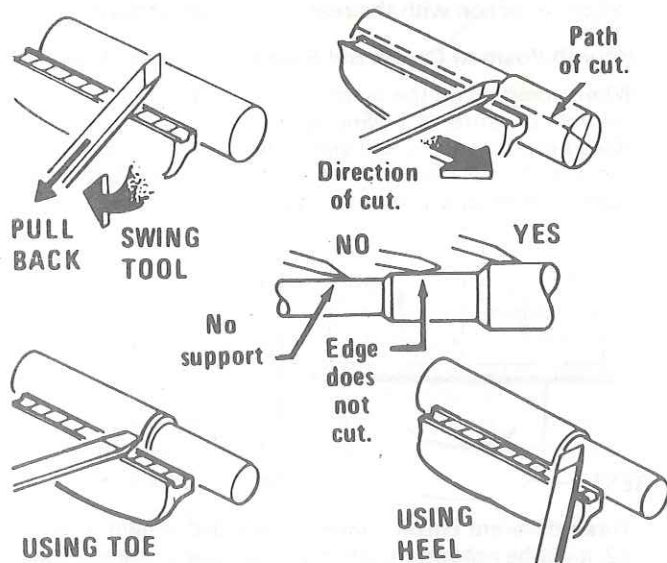

For finish cutting, the skew is held with the cutting edge considerably in advance of the handle, bevel side down. Keep the base of the bevel against the work. Good practice is to place the skew well over the work, pull it back until the edge begins to cut, then swing the handle into position to advance the cut. Both the toe and the heel of the skew can be used for taking light cuts; but do not penetrate the wood too deeply without cutting clearances, as there is danger of burning the tip of the tool.

USING THE PARTING TOOL

The parting tool has just one primary purpose: to cut straight into the workpiece as deep as desired, or all the way through to make a cut-off. It is therefore a very narrow tool — 1/8-in. wide — and is shaped to cut its own clearance so that the edge will not be burned. When used for scraping, however, it should be backed off regularly to prevent overheating.

Unlike the gouge and skew, the parting tool is seldom held with the bevel against the work. As the amount of stock removed is small, a support for the bevel is not necessary.

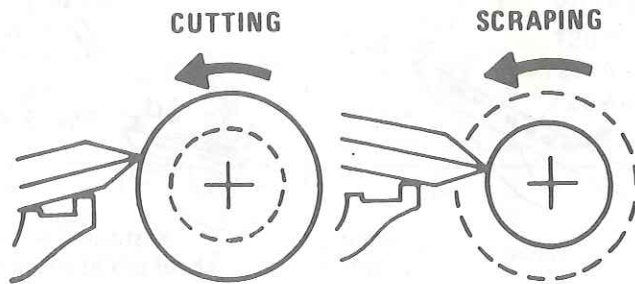

The tool is simply fed into the work at an angle (for cutting), or pointed at the workpiece center (for scraping). It can be held easily in one hand.

USING THE SCRAPING CHISELS

A 1/2-in. wide spear point chisel, a 1/2-in. wide round nose chisel, and a 1-in. wide flatnose chisel complete the list of tools ordinarily used by home craftsmen. Each of these scraping chisels can be purchased in various other sizes for special purposes. All are very useful for diameter scraping operations and for circumference scraping, when cutting methods cannot be employed.

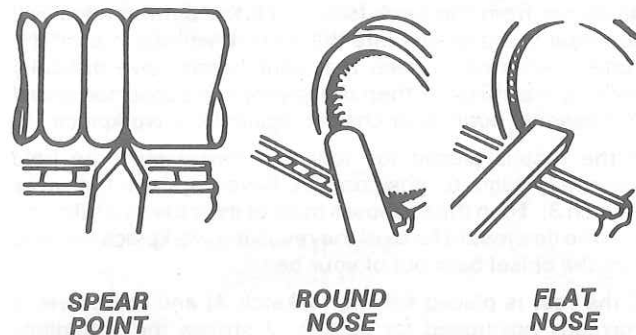

The spear point is used for fine scraping and delicate operations, such as the forming of beads, parallel grooves and shallow vees. Edges and bowl contours can be rounded with the round nose chisel. Any flat surface can be scraped with the flatnose chisel.

USING SHAPER OR MOULDING KNIVES

An old chisel can be made to serve as a holder for shaper or moulding knives. Such knives make it possible to scrape many interesting shapes in the workpiece surface in one or two operations, instead of the many operations required with standard chisels. It is generally not practical to use cutting methods with special shape tools; scraping methods should be used.

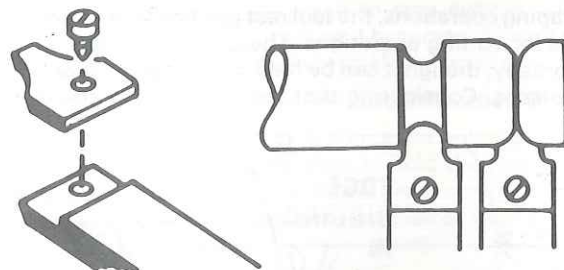

The holder should provide a shoulder against which the butt end of the knife can be firmly seated; and the knife must be securely mounted, either by means of a screw threaded into the holder, or by compressing it between two prongs bolted together.

USING A BLOCK PLANE



Clear, glass-smooth finishes (especially on soft-woods) can be obtained by using a block plane set to take a fine shaving. The tool rest should be raised up approximately to the top of the workpiece — and the plane should be horizontal, but turned slightly in the direction of travel so that it will take a shearing cut. Two tool rests, one in front and the other behind the work, can be used to advantage in positioning the plane so as to exactly limit the depth of cut (and finished size of the workpiece).

USING WOOD RASPS AND FILES

A wood rasp will remove stock quickly when held against the revolving workpiece. Care should be taken to support the rasp firmly against the tool rest, however, as it can tear the hands painfully if caught by a rough edge of the workpiece and kicked back. The rasp will leave a very rough finish.

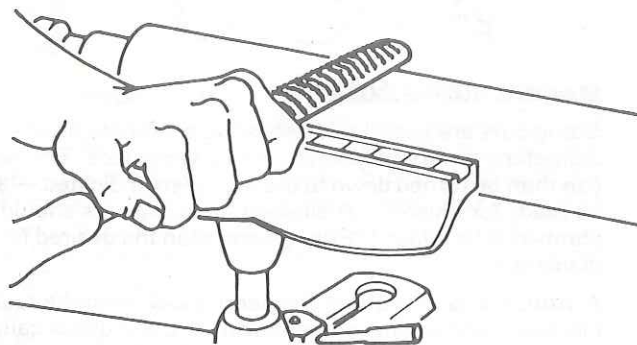

Finer finishes (similar to those produced by scraping) can be obtained by using files in the same manner. Various shape files can be used for shaping vees, beads, coves, etc. If pressed into the wood too hard, however, a file can burn the workpiece surface. Keep the file clean to keep it cutting uniformly. Files work best on hardwoods.

HAND POSITIONS

WARNING: Keep firm hold and control of the turning tool at all times. Avoid awkward hand positions where a sudden slip could cause a hand to move into the workpiece.

In handling all of the chisels the handle hand takes a natural position, being nearer or farther from the end depending upon the amount of leverage required. The position of the tool rest hand is a matter of individual liking; but there are three generally accepted positions, each best for certain types of operations.

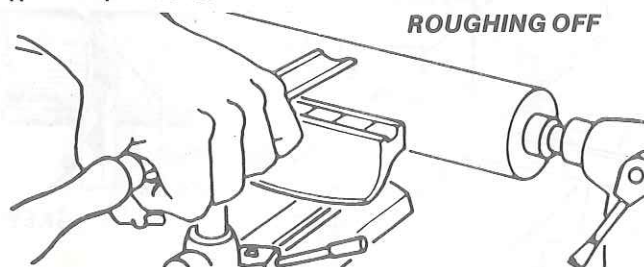

Roughing-off and other heavy work requires a firm grip and solid positioning of the chisel against the rest. This is best

obtained by the tool-rest hand position illustrated. The wrist is dropped down so that the heel of the hand below the little finger acts as a sliding guide against the rest. The handle hand controls chisel position.

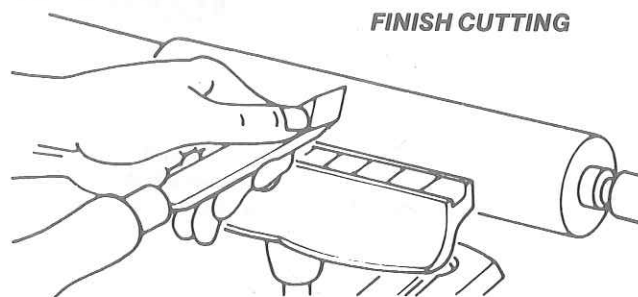

Finish cutting requires more control, with less force — and is better done with the palm of the tool-rest hand turned up. The wrist is still held down, and the side of the index finger acts as a guide along the rest. In this position, control of the chisel is shared by both hands, the fingers of the tool-rest hand being free to assist in positioning the tool.

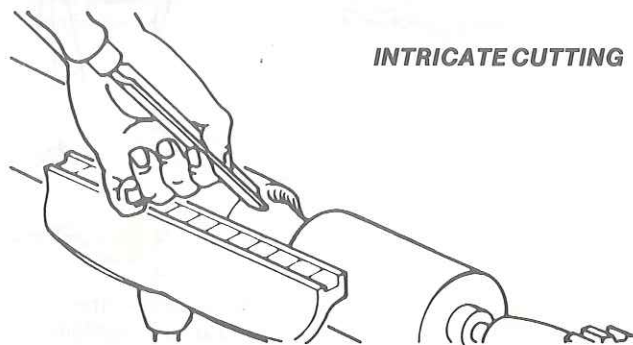

Intricate, delicate cutting requires extreme control, with practically no force. This is best accomplished by guiding the chisel with the fingers of the tool-rest hand. The hand is held palm up, with the wrist high — with the little finger placed against the rest to steady the hand. The chisel does not touch the rest; and the handle hand is completely secondary to the tool-rest hand.

The first and second positions are equally good for scraping operations; but the third position is practically never used for scraping.

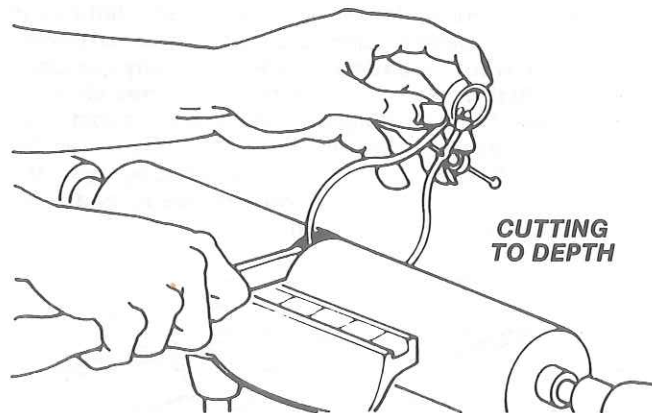

Many scraping operations and cutting to depth with the parting tool can be done with one hand. The chisel is grasped firmly, with the index finger on top to press it down against the rest — and is thrust straight into the work. Holding the tool thus leaves the other hand free to hold a pattern, calipers, etc., to check work progress.

how to use your craftsman wood-lathe

MAKING STANDARD CUTS

THE ROUGHING-OFF CUT

Reducing a square or odd-shaped workpiece down to a cylinder of approximate size for finish turning is called *roughing-off*. Faceplate turning and large diameter spindles should first be partly reduced by sawing but small spindles are easily turned down entirely with the large (3/4-in.) gouge.

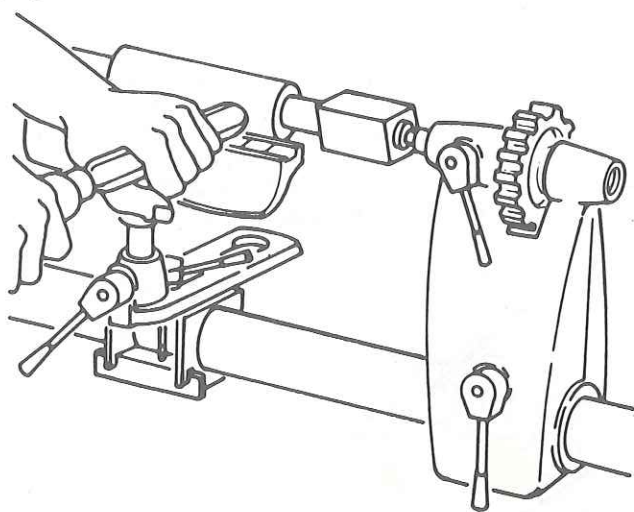

Start the first cut about 2-in. from tailstock end — then run it toward the tailstock and off the end of the workpiece. Next, start another cut 2-in. nearer the headstock — and run it, also, toward tailstock, to merge with first cut. Continue in this manner until 2- to 4-in. from the headstock end, then reverse the direction of tool travel and work one or two cuts in succession toward the headstock, and off this end of the workpiece. Never start a cut directly at the end — if the chisel catches the end, it will damage the workpiece. Never take long cuts while corners remain on the work, as this tends to tear long slivers from the corners.

The first series of cuts should not be too deep. It is better to partially reduce the work to a cylinder all along its length; then start a second series of cuts to complete reducing it to a cylinder. Once cylinder has been formed, step lathe up to the next faster speed. Further reductions in size can now be carried out by cutting as deeply as desired at any spot along the work. At this stage, long cuts, from the center off either end, can also be taken. Roughing-off generally is continued until the cylinder is approximately 1/8-in. larger than the desired finish size. Roundness can be tested by laying the gouge on top of the work — it will not ride up and down when cylinder is perfectly round.

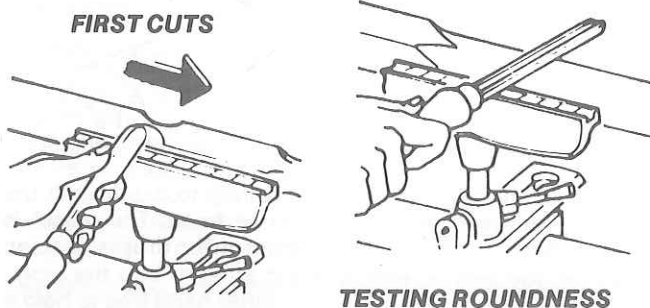

ROUGH-CUTTING TO SIZE

The roughing-off cut can be made to accurately size the cylinder to a given diameter.

Another method is to make a number of sizing cuts at intervals along the work, then use the gouge to reduce the whole cylinder down to the diameter indicated by these cuts.

A SIZING CUT

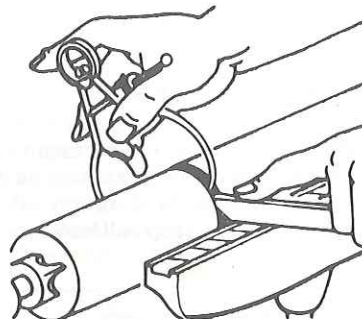

MAKING SIZING CUTS

Sizing cuts are useful to establish approximate finish-size diameters at various points along a workpiece. The work can then be turned down to the diameters indicated — and be ready for finishing. Diameters for sizing cuts should be planned to be about 1/8-in. greater than the desired finish diameters.

A sizing cut is made with the parting tool. Hold the tool in one hand, and use the other hand to hold an outside caliper preset to the desired sizing-cut diameter. As the cut nears completion, lower the chisel point more and more into a scraping position. When the calipers slip over the workpiece at the cut, the cut is finished.

SMOOTHING A CYLINDER

The final 1/8-in. can be removed in two ways. Either use the 1-in. skew, working from center toward both ends and taking lighter and lighter cuts until finished.

CUTTING A SHOULDER

A shoulder can be the side of a square portion left in the workpiece, the side of a turned section, or the end of the workpiece. Most shoulders are perpendicular to work axis; but a shoulder can be at any angle desired.

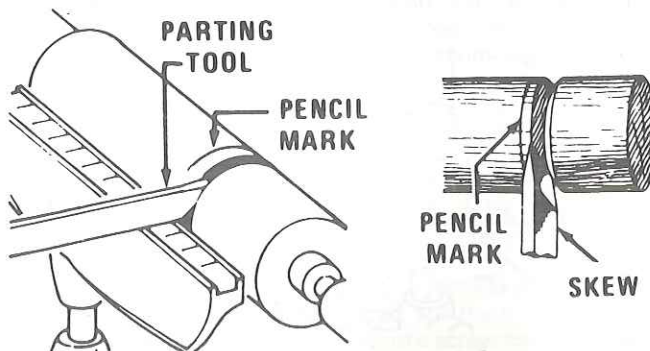

First, mark position of the shoulder with a pencil held to the revolving workpiece. Then make a sizing cut with the parting tool, placing this cut about 1/16-in. outside the shoulder position, and cutting to within about 1/8-in. of the depth desired for the area outside of the shoulder. If shoulder is shallow, the toe of the skew can be used to make the sizing cut; but do not go in deeper than 1/8-in. with the skew unless wider and wider vees are cut to provide clearance for this tool.

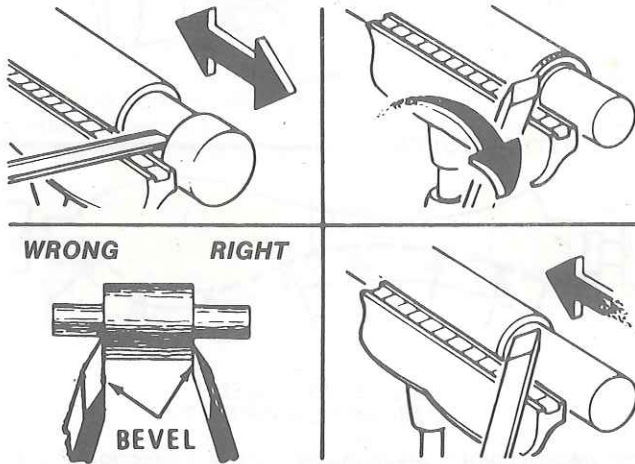

Use the gouge to remove any waste stock outside of shoulder — and smooth this section, up to within 1/8-in. of the shoulder, in usual manner. Finishing of the shoulder, unless it is more than 1-in. high, is best done with the 1/2-in. skew. First, toe of skew is used to remove thin shavings from the side of the shoulder — down to finish size. Hold skew so that bottom edge of bevel next to shoulder will be very nearly parallel to side of shoulder — but with cutting edge turned away at the top so that only the extreme toe will do the cutting. If cutting edge is flat against shoulder, the chisel will run. Start with handle low, and raise handle to advance toe into the work. Cut down to finished diameter of outside area; then clean out the corner by advancing heel of the skew into it along the surface of the outside area. Tilt the cutting edge, with handle raised up, so that only the extreme heel does this cutting.

If shoulder is at end of work, the process is called squaring the end. In this case, reduce outer portion to a diameter about 1/4-in. larger than tool center diameter, then later saw off the waste stock.

CUTTING VEES

Vee grooves can be cut with either the toe or heel of the skew. When the toe is used, the cutting action is exactly the same as in trimming a shoulder — except that the skew is tilted to cut at the required bevel. Light cuts should be taken on first one side then the other, gradually enlarging the vee to the required depth and width.

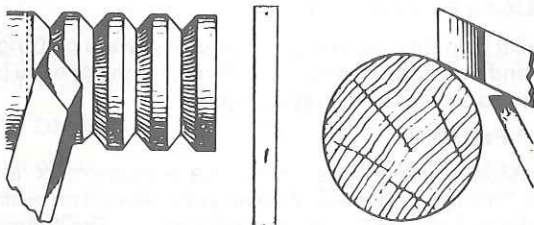

When the heel is used, the skew is rotated down into the work, using the rest as a pivot. Otherwise, cutting position and sequence of cuts is the same. As when using the toe, it is important that cutting be done only by extreme end of cutting edge.

If deep vees are planned, it is quicker to start them by making a sizing cut at the center of each vee. Vees can also be scraped with the spear point chisel or a three-sided file.

CUTTING BEADS

This requires considerable practice. First, make pencil lines to locate the tops (highest points) of two or more adjoining beads. Then make a vee groove at the exact center between two lines — and down to the desired depth of the separation between the beads. Be careful not to make the groove too wide or you will remove portions of the desired beads. The sides of the two adjoining beads are now cut with the heel of the skew — preferably 1/2-in. size, unless beads are quite large. Place skew at right angles with the work axis, flat against surface and well up near the top. The extreme heel should be just inside the pencil line that marks the top of the bead. Now draw skew straight back while raising handle slowly — until edge of the heel at the pencil line starts to cut. As edge begins to cut, roll skew in the direction of the vee — so that the exact portion of the edge which started cutting will travel in a 90° arc down to bottom of the vee. Upon reaching bottom of the vee, the skew should be on edge. Reverse the movements to cut side of the adjacent bead.

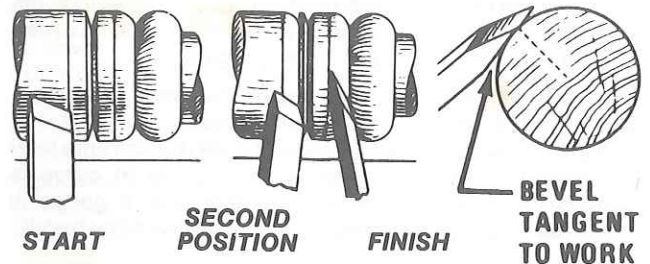

It is important that only the extreme heel should do the cutting. This means that the bottom edge of the bevel next to the vee must at all times be tangent to the arc of the bead being formed.

Easier beads can be shaped with the spear point chisel. Use pencil marks and sizing cuts as before. Push the chisel straight into each cut and rotate it horizontally to round off the adjacent edges. It must be moved slightly in the direction of rotation at the same time, to keep the point from digging into the adjacent bead.

CUTTING COVES (CONCAVES)

This is the most difficult single cut to master — but one of the most important in good wood turning. First, use pencil marks to indicate the edges. Then, rough it out — to within about 1/8-in. of the desired finish surface — by scraping with the gouge or round nose chisel. If the cove is to be very wide, sizing cuts can be made to plot the roughing out. Once it is roughed out, the cove can be finished in two cuts — one from each side to the bottom center.

At the start of either cut, gouge is held with handle high and the two sides of blade held between the thumb and forefinger of tool-rest hand, just behind the bevel. Position the fingers ready to roll the blade into cove. Hold blade so that bevel is at a 90° angle to the work axis, with point touching the pencil line and pointed into work axis.

how to use your craftsman wood-lathe

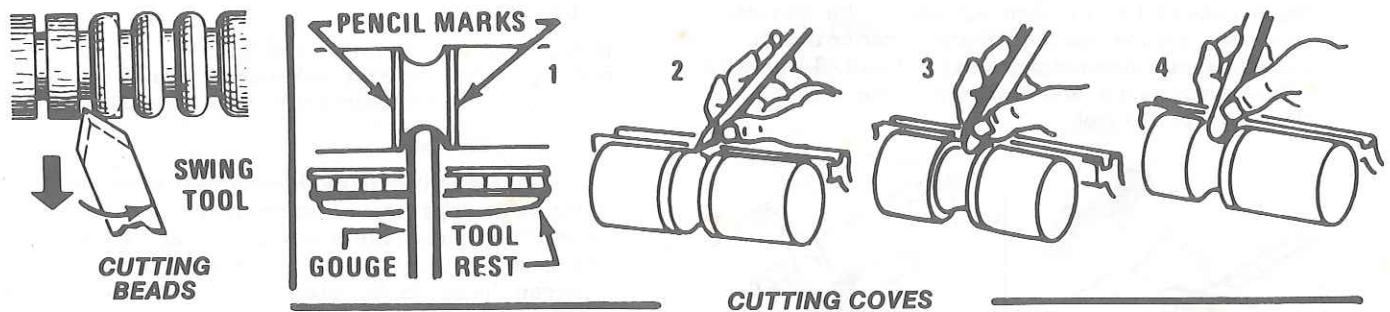

From this start, depress point slightly to start cut, then continue to move point down in an arc toward the bottom center of cove - at the same time rolling chisel uniformly so that, at the end of the cut, it will be flat at bottom of the cove. The object is to keep the extreme point of gouge doing the cutting from start to finish. Reverse movements to cut the opposite side.

Coves also can be scraped to finish, using the round nose chisel or a rattail file - but these methods do not generally produce perfectly curved coves.

MAKING LONG CONVEX CUTS

First turn work down to approximate size, using sizing cuts (as required) to determine various diameters. Finish cut can then be made with either skew or gouge.

If the skew is used, the principles of the operation are the same as those employed in cutting a bead - except that curve is longer and may be irregular. Use the extreme heel throughout - start at longer end of curve (if curve is irregular) and progress toward steeper end. If gouge is used, make cut in the same direction. Start with the handle

well back of point - swinging handle in the direction of tool travel to overtake the point, if necessary, when the steep part of the curve is reached. Object is to keep extreme point during the cutting throughout - with bevel as tangent to curve as possible.

MAKING LONG TAPER CUTS

Long taper cuts are made like long convex cuts, with the skew or gouge. However, the angle between the cutting edge and handle is kept constant during the entire cut. The handle is not swung around. Always cut downhill. Do not cut too deeply at the center of the taper.

HOW TO HANDLE SPINDLE TURNINGS

PLOTTING THE SHAPE

Once the basic cuts have been mastered, you are ready to turn out finished work. The first step is to prepare a plan for the proposed turning. This can be laid out on a suitable sheet of paper - and should be to full size. Next, prepare the turning stock by squaring it up to the size of the largest square or round section in your plan. The stock can be cut to the exact length of the proposed turning; but, in most cases, it is best to leave the stock a little long at one or both ends to allow for trimming.

an ordinary ruler - or by using a template. Make the pencil marks about 1/2-in. long - they will then be visible when the work is revolved under power, and can be quickly traced around the spindle by touching each line with the pencil.

After marking, use the parting tool to make sizing cuts at all of the important shoulders. When learning, you will find it best to make many sizing cuts to accurately plot the various diameters; but experienced workers can do with a few such cuts at the important shoulders. Plan each sizing cut so that it is in waste stock; and make each deep enough so that there will be just enough wood left under the cut for the finishing process. Once the sizing cuts have been run in, rough-out the excess wood with a gouge - then proceed with the finishing process by making the various types of cuts required.

DIAMETERS

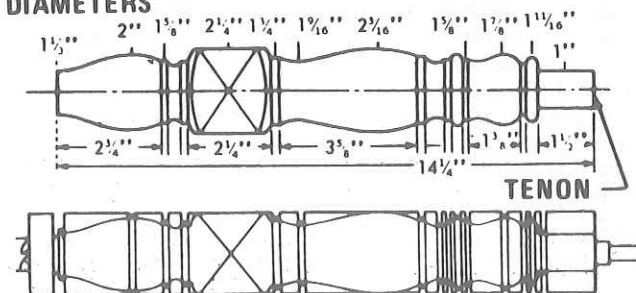

DUPLICATE TURNINGS

Identical turnings require great accuracy when plotting the work and doing the various cuts. Many methods have been devised to aid in perfecting the work.

Use of Patterns

Professional workers generally use a pattern, or layout board. This is a thin piece of wood or cardboard on which is drawn a full-size half section of the turning. The contour of the finished surface is drawn first; then the diameters at various critical points are drawn to scale as vertical lines intersecting the contour line. By placing the pattern against

Mount the stock in the lathe, and rough it off to a maximum-size cylinder. Now project your plan onto the turning by marking the various critical dimensions along the length of the spindle in pencil. These dimensions can be laid out with

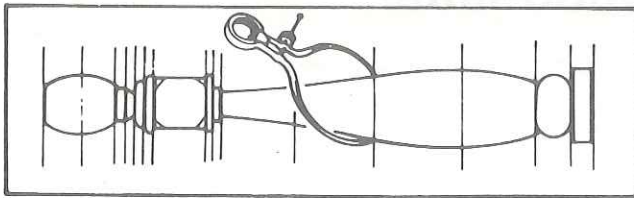

the roughed-off cylinder, you can quickly mark the various points of the critical diameters. To make each sizing cut, use outside calipers and set these by actually measuring the length of the vertical line on the pattern which represents the diameter desired. Then make the sizing cut, down to the proper diameter by using the calipers to determine when the cut is finished. After making the sizing cuts, hang the pattern behind the lathe where it will serve as a guide for completion of the workpiece.

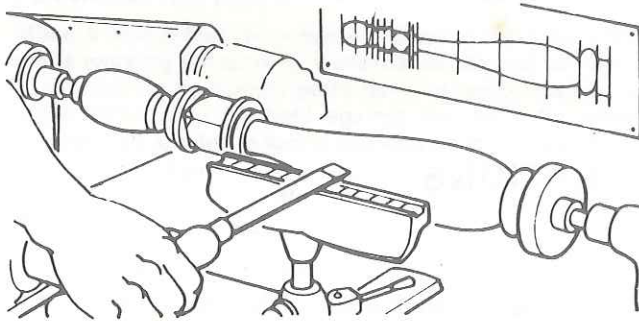

Using a Template and a Diameter Board

When many identical turnings are to be produced, it is a convenience to have a prepared template. This can be made of thin wood or cardboard — and is cut on a band saw or scroll saw to have the exact contour of the finished turning. The number one finished turning can also be used as a template. Attach the template to a board; then mount the board behind the lathe, on hinges, so that the template can be moved down to touch the workpiece and allow you to closely observe progress of your work.

USING A TEMPLATE

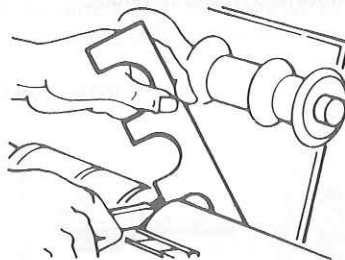
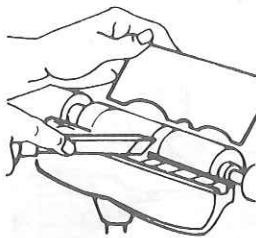

USING A DIAMETER BOARD

If a great many turnings are being produced, a diameter board will save the time used for resetting calipers. This is simply a thin board along the edge of which a number of semi-circular cuts have been prepared to represent all the various caliper settings required for measuring the sizing cuts. Each semi-circular cut is held against the workpiece instead of using the calipers.

USING DIAMETER SIZING GAUGE - 24909

Production work can be further speeded by the use of the Diameter Sizing Gauge - 24909 to take the place of caliper measurements. The positions of the arms are set to indicate

the various sizing cuts to be made. Each arm is of such a length that it will drop all of the way down past the back side of the workpiece when the wood under it has been cut out to the desired depth of the sizing cut.

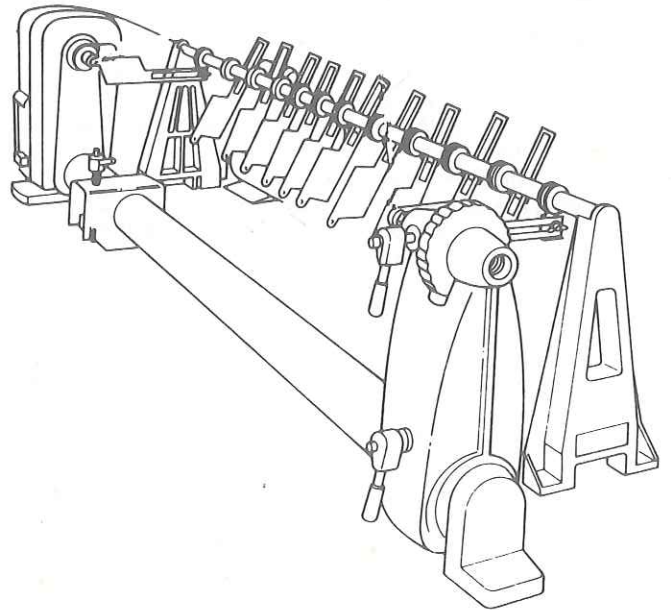

USING COPY CRAFTER - 24908

To make identical spindles for chairs, table legs, or to exactly copy an existing turning the Copy Crafter - 24908 is used. Follow the outline of original turning or template and the cutting tool duplicates the workpiece. Spindle turnings up to 2-1/2 inches in diameter, 36 inches long can be duplicated from original turnings; up to 6 inches in diameter; 36 inches long from a template. Shallow faceplate turnings up to 8 inches in diameter can be duplicated from templates.

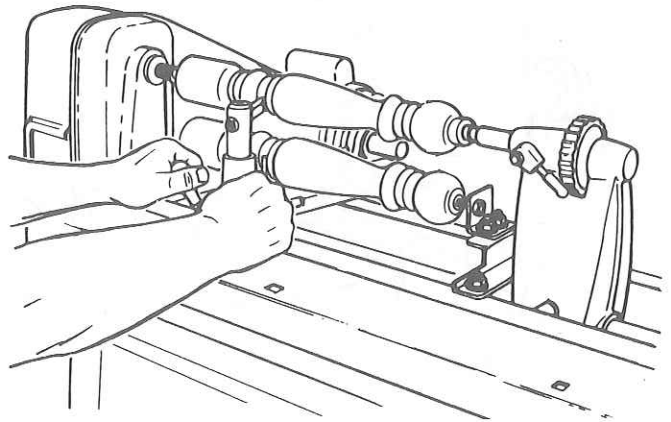

LONG SPINDLES

A long turning can be worked in short sections, with joints arranged to be at shoulders where they will not be noticed.

Long thin work that is likely to whip while turning should be supported at one or two places by a backstick. This is easy to make. A simple one consists of a short length of wood mounted vertically in an extra tool rest, and notched so that it can be used to support the spindle from behind. An improved type — which uses 2 roller skate wheels to form the notch — also is shown.

how to use your craftsman wood-lathe

USE OF BACKSTICKS

Position the backstick against a pre-turned portion near the center of the spindle, this portion being at least 1/8-in. over finish size to allow for later removal of any marks made upon it. Operate lathe at a slower speed than normal. Lubricate the workpiece at point of contact with the backstick, using beeswax (preferably), lard or grease. After completing the turning, remove the backstick and finish off the original point of contact. Sand off any slight burns remaining on workpiece.

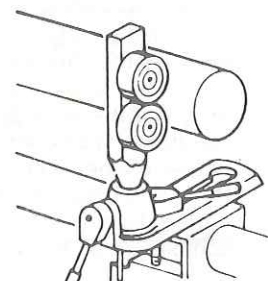
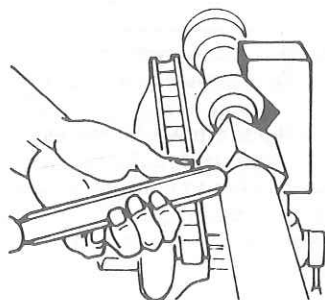

MISCELLANEOUS OPERATIONS

GUIDE BLOCKS FOR SCRAPING OPERATIONS

A guide block can be clamped to a chisel to limit the depth of cut and aid in the production of perfect cylinders, tapers and facings on faceplate turnings. Scraping methods must be used when the guide block is employed.

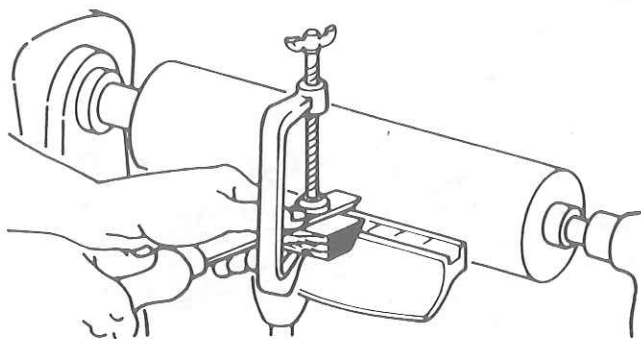

DRILLING

For cross drilling flat sided work, use a (metal-lathe) drill pad in the tailstock and place a scrap board between the pad and the work. For cross drilling round stock, use a (metal-lathe) crotch center in the tailstock. Work in which it is desired to drill random holes can be positioned as desired on supporting blocks laid upon the lathe bed. It can be held by hand — or can be supported from behind by a drill pad mounted in the tailstock.

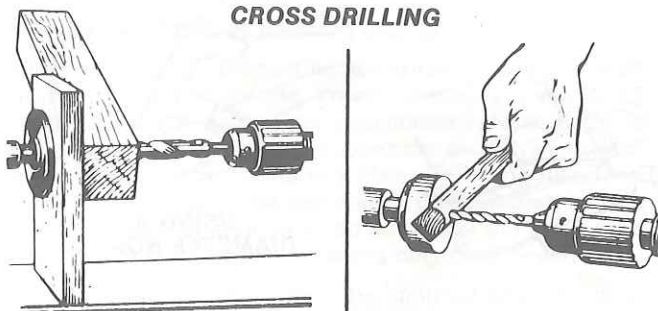

FACEPLATE & CHUCK TURNINGS

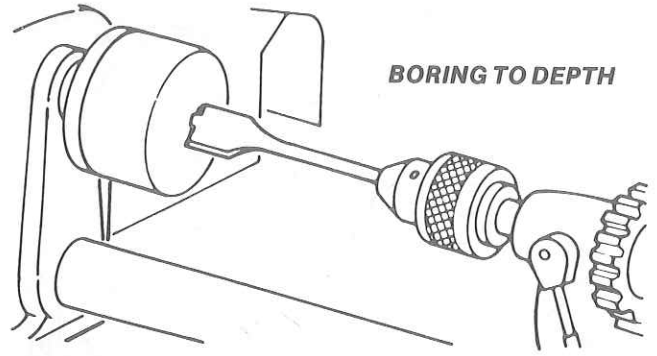
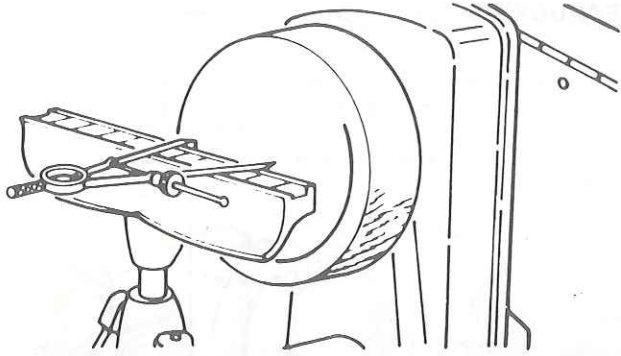

PLANNING THE WORK

Make a layout first, to provide a visual pattern to follow while working the turning. Patterns can be laid out in the same manner as spindle patterns — or templates can be made which can be held against the work for visual comparison. Circles to locate the various critical points (at which the contours of the faceplate take distinct form) can be quickly scribed on the rotating work by using the dividers.

PLANNING VARIOUS CUTS

The circumference of a faceplate turning is roughed-off and finished in the same manner that a spindle is worked. Practically all of the balance of the operations, however, are done by using scraping methods. A few of the standard contours which must often be turned are illustrated in the accompanying sketch — which also shows the proper chisels for shaping these contours. Any roughing-out to depth that must be done is generally accomplished with the gouge held in the scraping position.

DEEP RECESSES

The first step is to remove as much wood as possible by boring into the center with the largest wood bit available. This can be accomplished as illustrated. Be careful to measure in advance the depth to which drill can be allowed to go.

Now remove the bulk of the waste (to rough-out the desired recess) by scraping with the roundnose chisel or the gouge. Remove up to within 1/8-in. of finished size in this manner. Finish off the inside circumference by scraping with the spear-point chisel or skew. Smooth the bottom of the recess by scraping it flat with the flatnose chisel.

Proper support must be provided at all times for the scraping chisels. Several tool rest positions are shown in the accompanying illustrations. Always endeavor to position the part of the rest that supports the tool as close to the working surface as possible.

The depth and squareness of the sides of the recess can be quickly checked by holding one of the straight sided chisels and a combination square as shown.

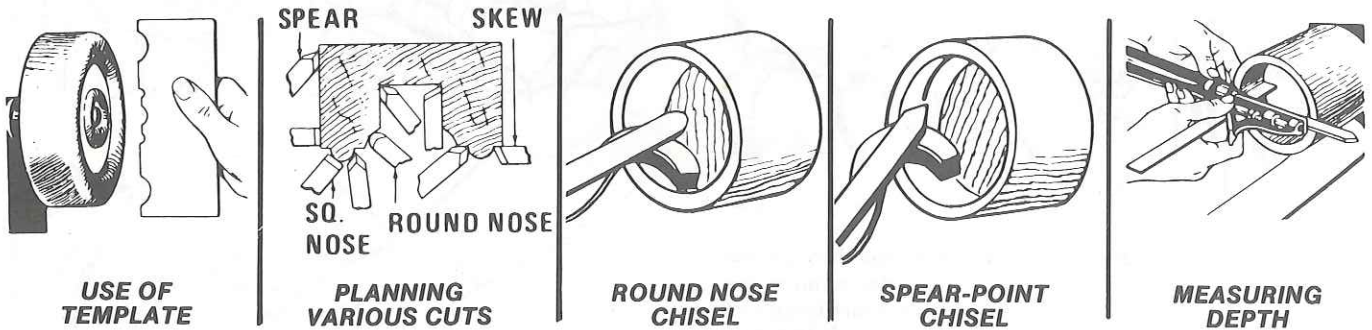
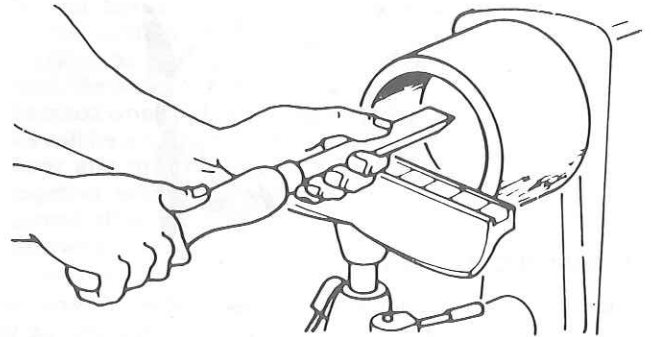

how to use your craftsman wood-lathe

HOW TO MAKE FANCY FACEPLATE TURNINGS

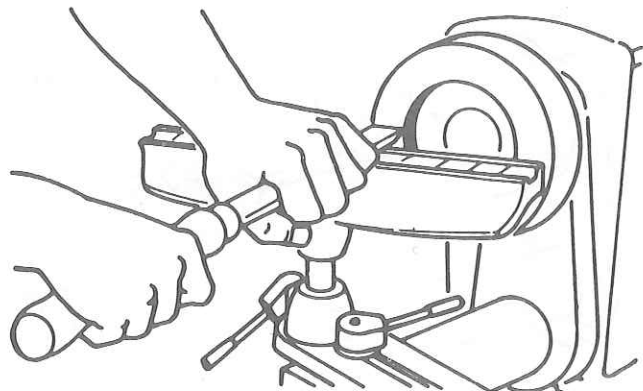

PREPARING A PLUG CHUCK

A plug chuck is an auxiliary wood chuck mounted onto a faceplate. The chuck can be any size in diameter — should be about 2-1/2-in. thick for stability — and should be provided with a 3/4- or 7/8-in. hole in the center for receiving a tenon turned at the end of the workpiece. Once made, such chucks are permanent useful fixtures for turning balls, goblets, etc. In use, the wood stock for turning is turned between centers to produce a tenon at one end which will be a driving fit in the hole of the chuck. When mounted in the chuck, the workpiece is substantially supported for any faceplate type of turning.

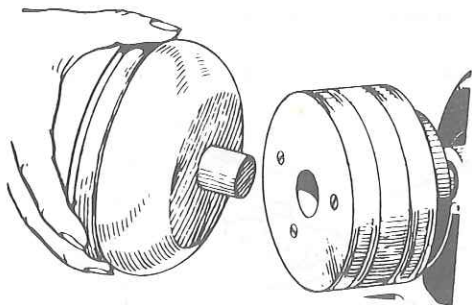

TURNING CYLINDERS

Stock for cylinders should be mounted on the screw center or a small faceplate. The tailstock can be brought up to support the work while the circumference is being turned and finished. Afterwards, the tailstock is backed off and the outer end of the cylinder is recessed, using methods already described for making deep recesses.

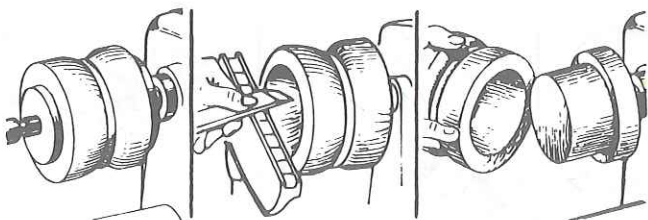

After making a recess at least 1/2 of the way through the workpiece, and finishing this on the inside, remove the workpiece from the lathe. Now mount a short length of softwood stock on the screw center and turn this down to form a dowel that will be a tight press (not driving) fit inside the recessed end of the cylinder. Mount the cylinder on this wooden chuck, and recess the unworked end deep enough to form a perfect hole through the entire cylinder.

RECHUCKING

Rechucking is the general term used to describe any additional work mounting that is necessary to complete a turning project. The method of working cylinders, and the use of a plug chuck as already described, are typical examples. Another good example is the rechucking of a bowl.

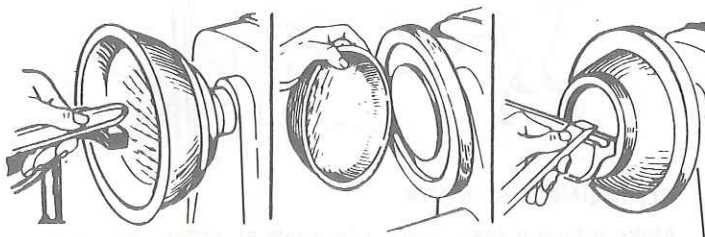

The work is first mounted on a wood backing block secured to the large faceplate, and is turned in the usual manner — all except the back side (which is against the mounting block). It is then removed from the mounting block. An auxiliary chuck of softwood is now made in the same manner that the cylinder chuck is made. This chuck must have a turned recess properly sized to accommodate the rim of the bowl in a tight press fit. When the bowl is mounted in this chuck, the bottom can be cleaned off and slightly recessed to complete the desired contours.

TURNING A RING

One method of turning a ring requires a spindle chuck. The work stock is first mounted to a backing block held by the large faceplate, and is turned to shape on the outer side. The inside diameter of the ring is also shaped, all the way through to the backing block. The work is then removed from the backing block. A spindle chuck is now prepared so that it will be a tight press fit inside the ring, and the ring is reversed and mounted on this chuck. Thus mounted, the remaining contours can be turned to shape.

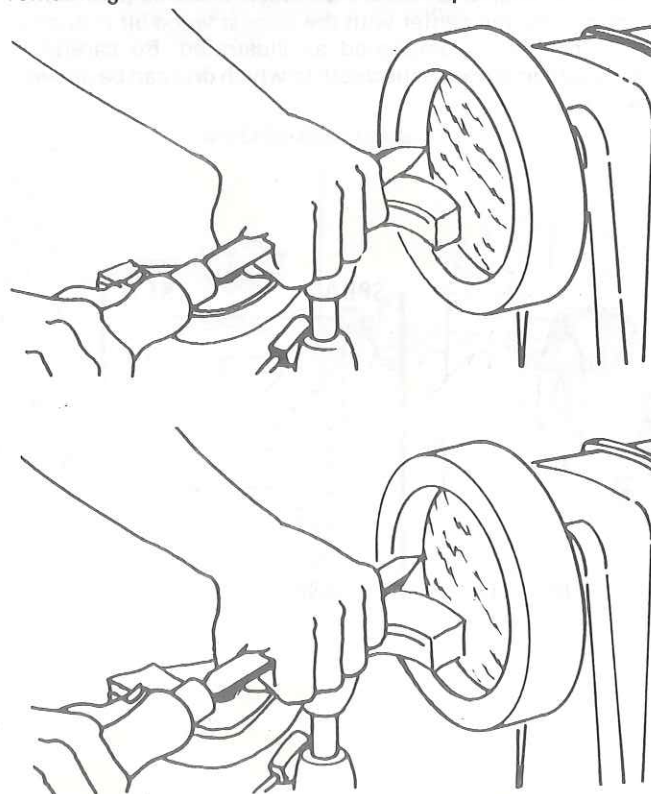

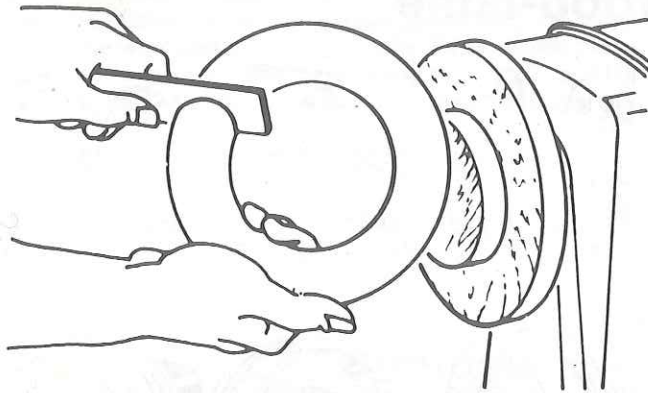

Another method of turning a ring makes use of a recessed chuck. The work stock is mounted on a screw center and one half of the ring is formed; but the ring is not cut away from its center. The stock is then removed, and a recessed chuck — mounted on the large faceplate — is prepared to receive the ring in a tight press fit. After being chucked, the remaining face of the ring can be turned to the proper contour, thus cutting away the center portion. In work of this type take constant measurements — or better still, use a template — to guard against over or under cutting.

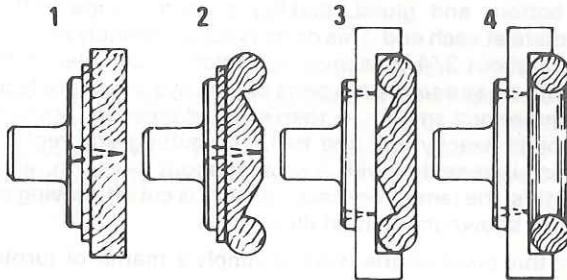

TURNING BALLS

Wooden balls of large size are first roughly turned between centers, using standard procedures. Smaller balls can be mounted as faceplates on the small faceplate or screw center. Lines drawn to indicate the center and ends of the ball shape are helpful in plotting the curve. A template should always be used for accurate visual observation of the work progress.

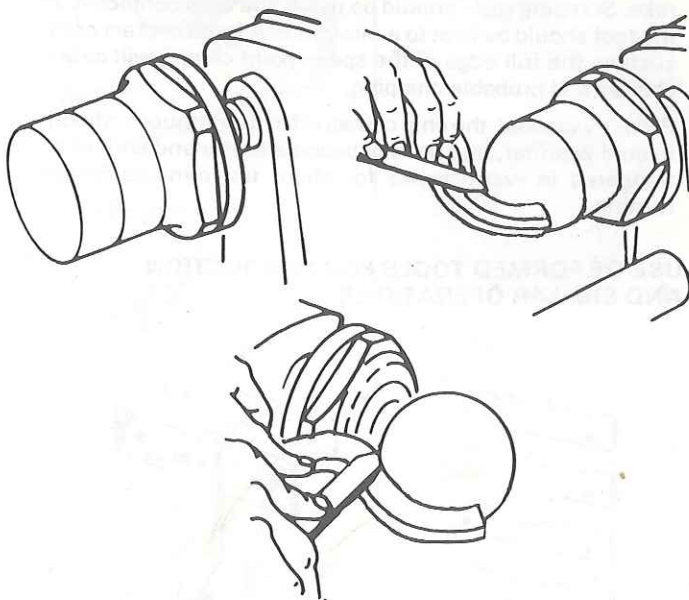

If the ball is mounted as a faceplate turning, almost the entire surface can be turned before it becomes necessary to rechuck it. Rechucking can be accomplished in a deep cup chuck which will hold the finished portion of the ball in a tight press fit. Another method of rechucking is to use a shallow cup chuck which will not support the ball alone, but must be used in conjunction with the tailstock. When using the shallow chuck, a wood block is fitted to the tailstock so that the ball can revolve upon it. This block should be lubricated with beeswax or grease. In using the shallow chuck method, the ball is constantly shifted — never more than 1/8 turn — and always with a definite system. Since turning between centers makes the work a perfect sphere across the grain, the ball must be mounted in the chuck so that the first scraping, cut will be mounted in the opposite direction.

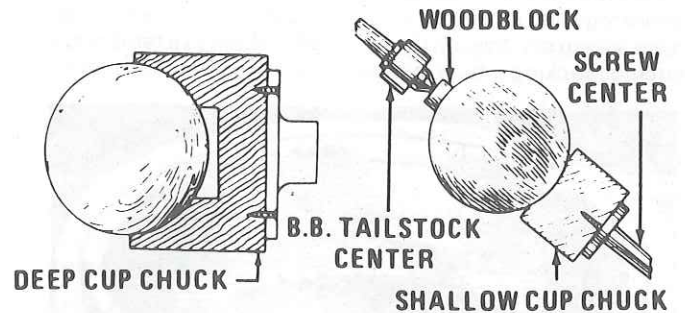

TURNED BOXES

Turned boxes involve deep recessing together with a special system of working the lid and body of the box together as one unit. The inside of the lid is turned first. Next, the inside of the body is turned. A careful check must be made when turning the lip of the body portion so that the lid will be a tight press fit. The lid is then pressed onto the body and the outer circumference and face of the lid, together with the outer circumference of the body, are turned all at one time. This insures accurate matching of the two pieces. After the work is complete, the tight fit of the lid can be relieved by sanding the lip of the body.

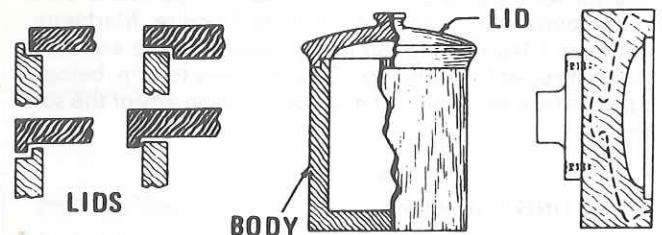

BACKING BLOCK

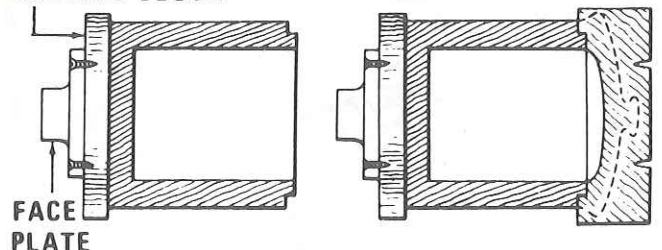

how to use your craftsman wood-lathe

SEGMENTED TURNINGS

Segmented bowls and boxes are exceptionally attractive—and this method of preparing wood stock is more economical than the use of the large solid pieces. For some types of work, segmenting is the only practical method because a block (if obtainable) would be so large that it would be very likely to warp.

The bowl illustrated requires 12 segment pieces for the sides. Bowls can be worked with 6 or 8 pieces if desired. To make the 12-piece bowl, a board about 7/8x3x30 in. is cut into pieces about 2-1/2-in. long, the saw blade being tilted 15° and the board being turned alternately face up and face down to make the successive cuts. These 12 pieces are glued together and clamped by wrapping the assembly with wire. When dry, the rim thus formed is glued to a temporary circular backing which is mounted on the large faceplate.

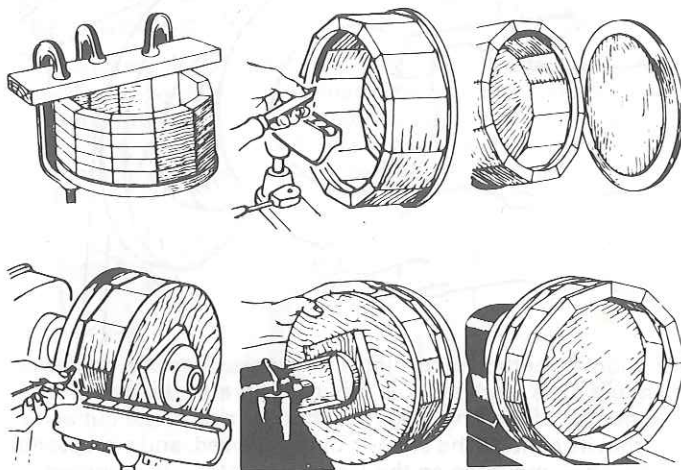
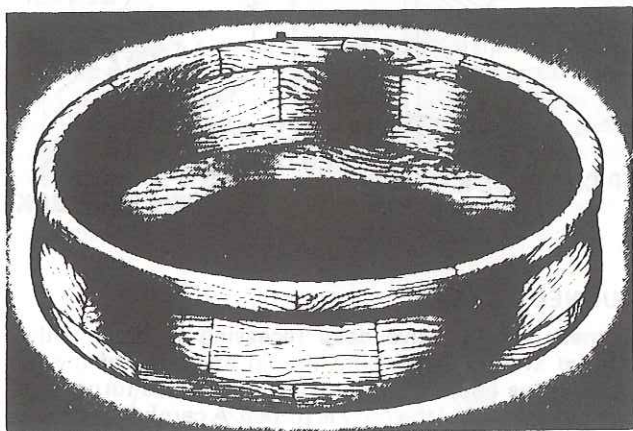

A recess of the largest possible diameter, and about 3/4-in. deep, is turned in the open end of the rim. The rim is removed from the lathe, and stock for the bottom is mounted in its palce on a second faceplate. This is turned to size—and a rim about 1/8-in. deep is turned to exactly fit the recess prepared in the rim. The rim is then fitted over the bottom and glued, making a drum shape with a faceplate at each end. This drum is cut completely in two at a point about 3/4-in. above the bottom—completing the cut with a hand saw. Both parts of the cut surface are faced off square and smooth—then reglued together, breaking the joints exactly half and half. The cutting and regluing process is repeated with a section about 1-1/4-in. wide. After this, the temporary backing block is cut off, leaving the bowl as shown in the final illustration.

From this point on the work is simply a matter of turning down the bowl to any desired shape.

HOW TO TURN PLASTICS

TYPES OF PLASTICS

There are two general groups of plastics. The first includes all phenol plastics moulded under heat and pressure. Bakelite and Formica are examples. In the second are all catalyst setting plastics of various bases sold under such trade names as Lucite, Catalin, Cast Bakelite, Marblette, Tenite and Trafford. Those in the second group are most generally used for craftwork. They are easy to turn, being a little harder than wood but much softer than any of the soft metals.

MOUNTING THE WORK

Rods can be mounted between centers, using wood mounting centers. When the spur center is used, slots should be sawed across the work.

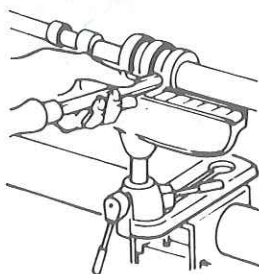

USE OF WOOD TURNING CHISELS

Standard wood turning chisels are excellent for turning plastics by means of scraping methods. The tool rest should be slightly below center and the chisel handle should be held a little higher than the cutting edge to give a negative rake. Scraping tools should be used. The area contacted by the tool should be kept to a minimum. A large contact area, such as the full edge of the spear-point chisel, will cause chatter and probable chipping.

Properly worked, the chip comes off in a continuous ribbon. In cold weather, plastic may become brittle and should be tempered in warm water for about ten minutes before turning.

USE OF FORMED TOOLS FOR PRODUCTION AND SIMILAR OPERATIONS

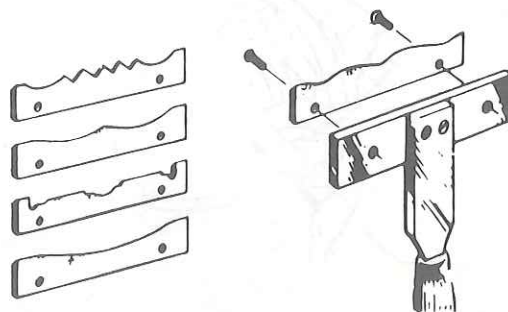

When a number of identical pieces are to be produced, all having a distinctive surface pattern, preformed tools will speed the work and assure uniformity. Patterns like those illustrated can be created by grinding thin (.020 to .010) gauge aluminum strips. A holder, like the one shown, can then be used to support any one of your prepared strips—and guide it against the workpiece.

POLISHING PLASTICS

Start with sanding. First use 150-grit dry paper to remove tool marks; then finish off with 150-grit and 400-grit papers, in succession, used wet. Press lightly to avoid overheating and marring of the work. Buffing gives the final polish, using the polishing compounds commonly supplied for this purpose. Do not press too hard or hold wheel at one spot too long — keep moving around — otherwise the plastic might become heat marked.

SANDING, BUFFING AND POLISHING

USING THE LATHE TO SAND TURNINGS

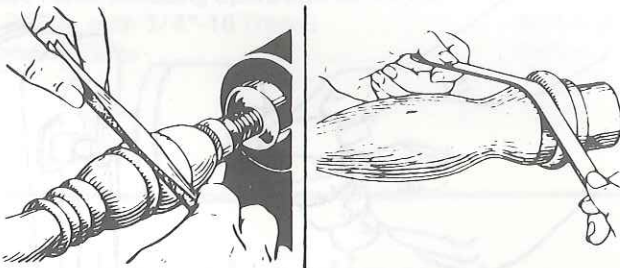

Turnings should be sanded with the lathe running in second lowest speed. A large sheet of sandpaper is useful for smoothing cylinders. All other sanding operations are done with a narrow strip of abrasive paper. The best finishing grit is 3/0 for softwoods, 4/0 for hardwoods.

Worn 2/0 paper is often used, and is the equivalent of 3/0 or 4/0 new paper.

The application of the sandpaper strip is shown in the illustrations. Care must be exercised in order to prevent dubbing the corners of beads, shoulders, etc. It is good practice to finish sanding with the work in reverse rotation. This is particularly true when sanding basswood, white pine and mahogany. These woods are hard to sand clean since sanding packs the surface fuzz down to the wood. Sanding very lightly, and not too long, with the lathe reversed, will lift the fibers and cut them off clean.

USE OF SANDING DISCS

A fully adjustable sanding table 9-24922 adds to the scope and convenience of sanding operations. Sanding is always done on the down-traveling side of the wheel; working on the other side would kick the work upwards. Either second or third speed can be used.

The sanding disc is a metal plate with a threaded shank which fits the end of the lathe spindle. Abrasive paper is glued to the machined surface of the plate by means of a quick-drying cement supplied for this purpose. Abrasive discs can be purchased or cut from the standard sizes of abrasive paper.

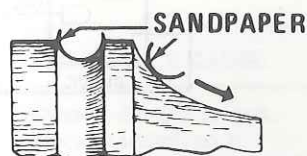
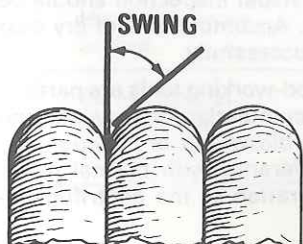
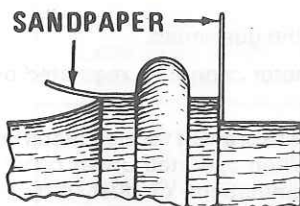
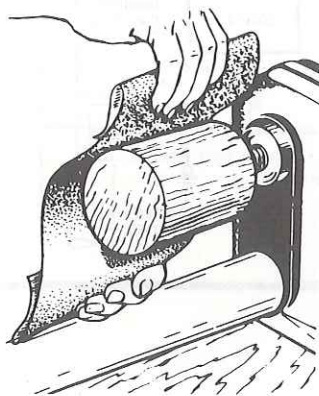

COVES

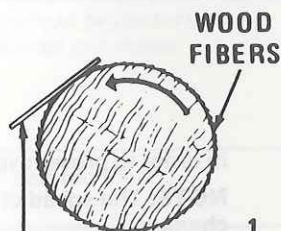

1

SANDPAPER

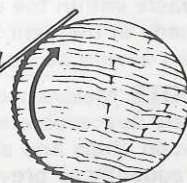

2

FIBERS LIFTED AND CUT OFF

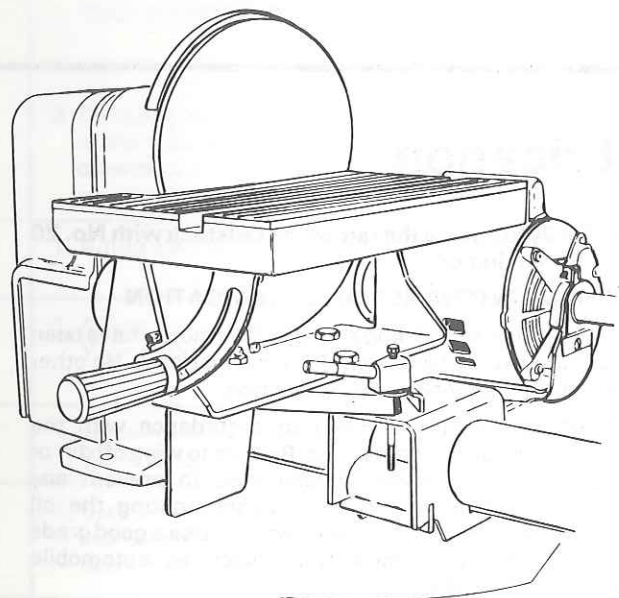

how to use your craftsman wood-lathe

USE OF SANDING DRUMS

Standard sanding drums are usually rubber cylinders which can be expanded to hold an abrasive sleeve in place. Similar cylinders turned on the lathe, and covered with abrasive paper glued or tacked in place, do satisfactory work. These have the advantage that special sizes, tapers, etc., can be made.

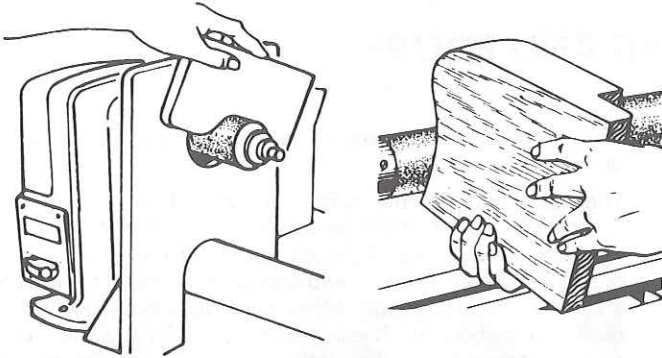

The drum is used mainly for sanding the edges of curved work. The squareness of the edge of the work can be best retained by using a simple form of vertical fence, as shown.

The standard sanding drums are commonly made with a threaded hole to fit the grinding wheel arbor. To guard against loosening of the tapered shank while the drum is in operation, it is advisable to support the free end, using either a ballbearing or plain 60° center in the tailstock.

USE OF WOOD CHUCKS FOR SANDING

Quick-acting chucks can be very useful for sanding operations on duplicate production parts. The chuck is made slightly oversize, and a piece of rubber hose (for small parts) is inserted in the recess to grip the workpieces. Workpieces can be changed without stopping the lathe.

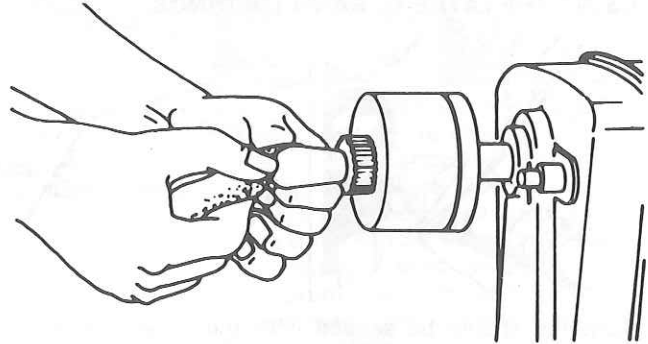

maintenance

WARNING: FOR YOUR OWN SAFETY, TURN SWITCH "OFF" AND REMOVE PLUG FROM POWER SOURCE OUTLET BEFORE MAINTAINING OR LUBRICATING YOUR LATHE.

Apply a coat of automobile-type wax to the lathe bed to help the tool rest and tailstock move freely.

Have power cord replaced if it becomes worn or frayed.

WIRING DIAGRAM

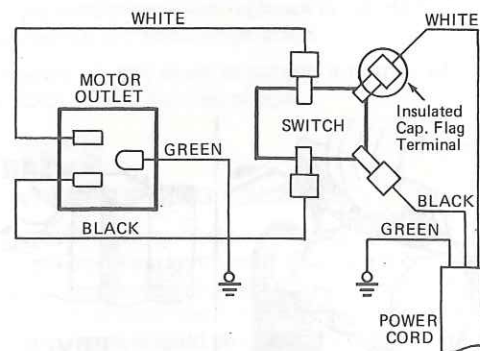

lubrication

Periodically lubricate the ram in the tailstock with No. 20 or No. 30 engine oil.

MOTOR MAINTENANCE AND LUBRICATION

1. The bearings, in both end shields of the motor, have been lubricated at the factory with correct lubricant. No other part of the motor requires lubrication.
2. Re-lubricate motor bearings in accordance with the instructions on the nameplate. Be sure to wipe off dirt or grit if present around oil hole caps to prevent any possibility of foreign material contaminating the oil wicks that supply the bearings with oil. Use a good grade of medium weight mineral oil, such as automobile engine oil SAE 20.
3. If disassembly of the motor is necessary, it should be returned to your nearest Sears retail or mail-order store

in order to prevent voiding the guarantee.

NOTE: The speed of this motor cannot be regulated or changed.

4. Every effort should be made to prevent foreign material from entering the motor. When operated under conditions likely to permit accumulations of dust, dirt, or waste within the motor, a visual inspection should be made at frequent intervals. Accumulations of dry dust can usually be blown out successfully.

NOTE: Motors used on wood-working tools are particularly susceptible to the accumulation of sawdust and wood chips and should be blown out or "vacuumed" frequently to prevent interference with normal motor ventilation and proper operation of the centrifugally-operated starting switch.

recommended accessories

ITEM	CAT. NO
Work Bench	(See Catalog)
Motor Pulley (Four Step) 1/2" Bore	9-27921
Motor Pulley (Four Step) 5/8" Bore	9-27922
Drill Chuck 1/2" Capacity with No. 1 M.T. Shank	9-22342
Screw Center with No. 1 M.T. Shank	9-21164
Ball Bearing Center with No. 1 M.T. Shank	9-21122
60° Center with No. 1 M.T. Shank	9-21102
Face Plate, 4" Dia. with 3/4"-16 Thread 9 holes	9-2489
Face Plate, Including Spurs and Screw Center 3" Dia. with 3/4"-16 Thread	9-20912
Sanding Table	9-24922

ITEM	CAT. NO.
9" Dia. Sanding Disc Only with 3/4"-16 Thread	9-24906
Turning Tools	(SEE CATALOG)
Draw Bolt with 1/4"-20 Threads	9-21542
Power Tool Know How Handbook	
Radial Saw	9-2917
Table Saw	9-2918
Bowl Turning Tool Rest	9-24903
Face Plate 6" with 3/4"-16 Thread 6 holes	9-24904
Copy Crafter	9-24907
Speed Reducer	9-23895
Face Plate 4" dia. with 3/4"-16 Thread Cast Iron, 6 holes	9-23865

The above recommended accessories are current and were available at the time this manual was printed.

trouble shooting

WARNING: FOR YOUR OWN SAFETY, TURN SWITCH "OFF" AND REMOVE PLUG FROM POWER SOURCE OUTLET BEFORE TROUBLE SHOOTING.

TROUBLE SHOOTING CHART

TROUBLE	PROBABLE CAUSE	REMEDY
Motor will not run.	<ol style="list-style-type: none"> 1. Defective On-Off switch. Defective switch cord. Defective switch box receptacle. 2. Motor protector open, (only if your motor is equipped with an overload protector). 3. Burned out motor 	<ol style="list-style-type: none"> 1. Replace defective parts before using Lathe again. 2. Reset protector when motor has cooled. 3. Consult Sears Service. Any attempt to repair this motor may create a HAZARD unless repair is done by a qualified service technician. Repair service is available at your nearest Sears Store.
Lathe slows down when turning	<ol style="list-style-type: none"> 1. V-belt too loose 	<ol style="list-style-type: none"> 1. Adjust belt tension, see Assembly Section.
Tailstock rocks back and forth excessively.	<ol style="list-style-type: none"> 1. Brass adjusting screw is too loose. 	<ol style="list-style-type: none"> 1. Adjust screw. See Section, "Getting To Know Your Lathe".
Headstock loose on bed.	<ol style="list-style-type: none"> 1. Setscrew not tight. 	<ol style="list-style-type: none"> 1. Tighten setscrew. See Section, "Getting To Know Your Lathe".
Wood burns at tailstock end.	<ol style="list-style-type: none"> 1. Cup center too tight or not lubricated. 	<ol style="list-style-type: none"> 1. Back off tailstock ram and lubricate cup center. See Basic Lathe Operation Section, "Spindle Turning."

trouble-shooting

TROUBLE SHOOTING -- MOTOR

NOTE: Motors used on wood-working tools are particularly susceptible to the accumulation of sawdust and wood chips and should be blown out or "vacuumed" frequently to prevent interference with normal motor ventilation and proper operation of the centrifugally-operated starting switch.

TROUBLE	PROBABLE CAUSE	REMEDY
Excessive noise.	1. Motor.	1. Have motor checked by qualified service technician. Repair service is available at your nearest Sears store.
Motor fails to develop full power. NOTE: LOW VOLTAGE: (Power output of motor decreases rapidly with decrease in voltage at motor terminals. For example, a reduction of 10% in voltage causes a reduction of 19% in maximum power output of which the motor is capable, and a reduction of 20% in voltage causes a reduction of 36% in maximum power output.)	1. Circuit overloaded with lights, appliances and other motors. 2. Undersize wires or circuit too long. 3. General overloading of power company facilities.	1. Do not use other appliances or motors on same circuit when using the lathe. 2. Increase wire sizes, or reduce length of wiring. See "Motor Specifications and Electrical Requirements" section. 3. Request a voltage check from the power company.
Motor starts slowly or fails to come up to full speed.	1. Low voltage will not trip relay. 2. Windings burned out or open. 3. Starting relay not operating.	1. Request voltage check from the power company. 2. Have motor repaired or replaced. 3. Have relay replaced.
Motor overheats.	1. Motor overloaded. 2. Improper cooling. (Air circulation restricted through motor due to sawdust, accumulating inside of motor).	1. Take shallower cuts. 2. Clean out sawdust to provide normal air circulation through motor. See "Maintenance and Lubrication" section.
Starting switch in motor will not operate.	1. Burned switch contacts (due to extended hold-in periods caused by low line voltage, etc.) 2. Shorted capacitor 3. Loose or broken connections.	1. Have switch replaced and request a voltage check from the power company. 2. Have capacitor tested and replace if defective. 3. Have wiring checked and repaired.
Motor stalls (resulting in blown fuses or tripped circuit breakers).	1. Starting switch not operating. 2. Voltage too low to permit motor to reach operating speed. 3. Fuses or circuit breakers do not have sufficient capacity.	1. Have switch replaced. 2. Request voltage check from the power company. 3. Install proper size fuses or circuit breakers.
Frequent opening of fuses or circuit breakers.	1. Motor overloaded. 2. Fuses or circuit breakers do not have sufficient capacity. 3. Starting switch not operating (motor does not reach speed).	1. Take shallower cuts. 2. Install proper size fuses or circuit breakers. 3. Have switch replaced.

repair parts

CRAFTSMAN 12-INCH WOOD LATHE, MODEL 113.228162

NOTE:

ANY ATTEMPT TO REPAIR THIS MOTOR
MAY CREATE A HAZARD UNLESS
REPAIR IS DONE BY QUALIFIED
SERVICE TECHNICIAN.

REPAIR SERVICE IS AVAILABLE
AT YOUR NEAREST SEARS STORE.

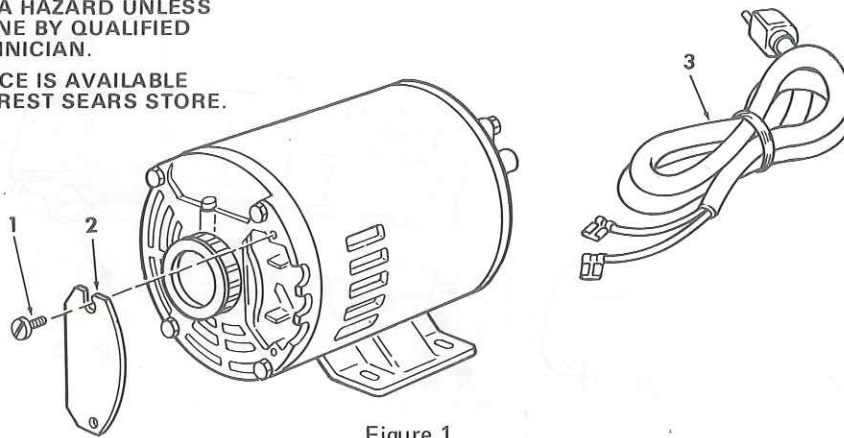

Figure 1

MOTOR PART NO. 70055

Key No.	Part No.	Description
1	60306	Screw, 8-32 x 3/8, Thread Cutting, Slotted, Serrated Hd.
2	64088	Cover, Terminal
3	64258	Cord with Plug

MOTOR CONNECTIONS

WARNING: FOR YOUR OWN SAFETY, TURN SWITCH "OFF" AND REMOVE PLUG FROM POWER SOURCE OUTLET BEFORE PROCEEDING.

1. Open motor connector box cover located on left end of motor (viewed from rear of saw) using a flat blade screwdriver.
2. Remove GREEN SCREW and lockwasher and insert screw through round metal terminal on the end of the GREEN wire of power cord with lockwasher between terminal and motor frame. (See illus.)
3. Reinsert GREEN SCREW in the threaded hole. Tighten securely.
4. Insert terminal end of WHITE wire on spade terminal marked T4 on the motor. Push terminal firmly until seated.
5. Insert terminal end of BLACK wire on spade terminal marked T1 on the motor. Push terminal firmly until seated.
6. Close motor connector box being sure that power cord is seated in the largest strain relief groove, and tighten box cover screws.

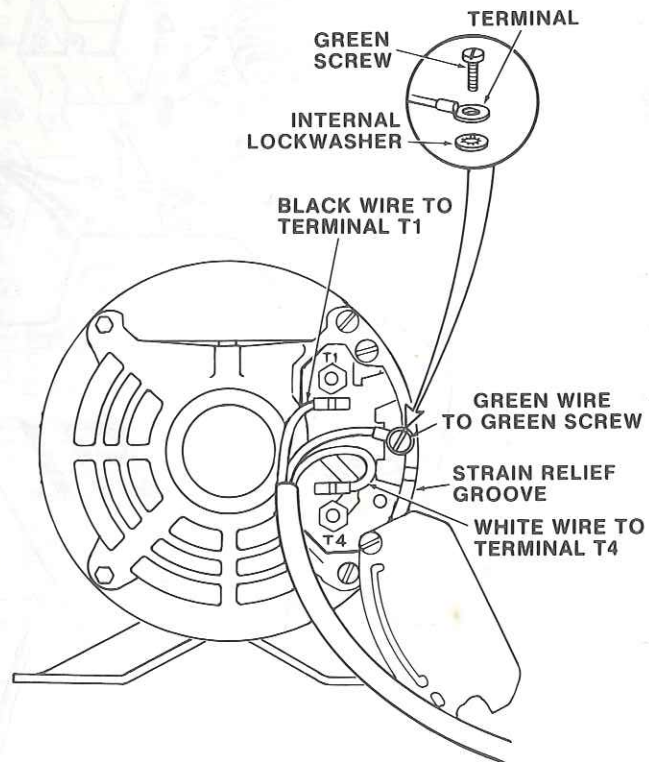

repair parts

CRAFTSMAN 12" WOOD-TURNING LATHE MODEL NO. 113.228162

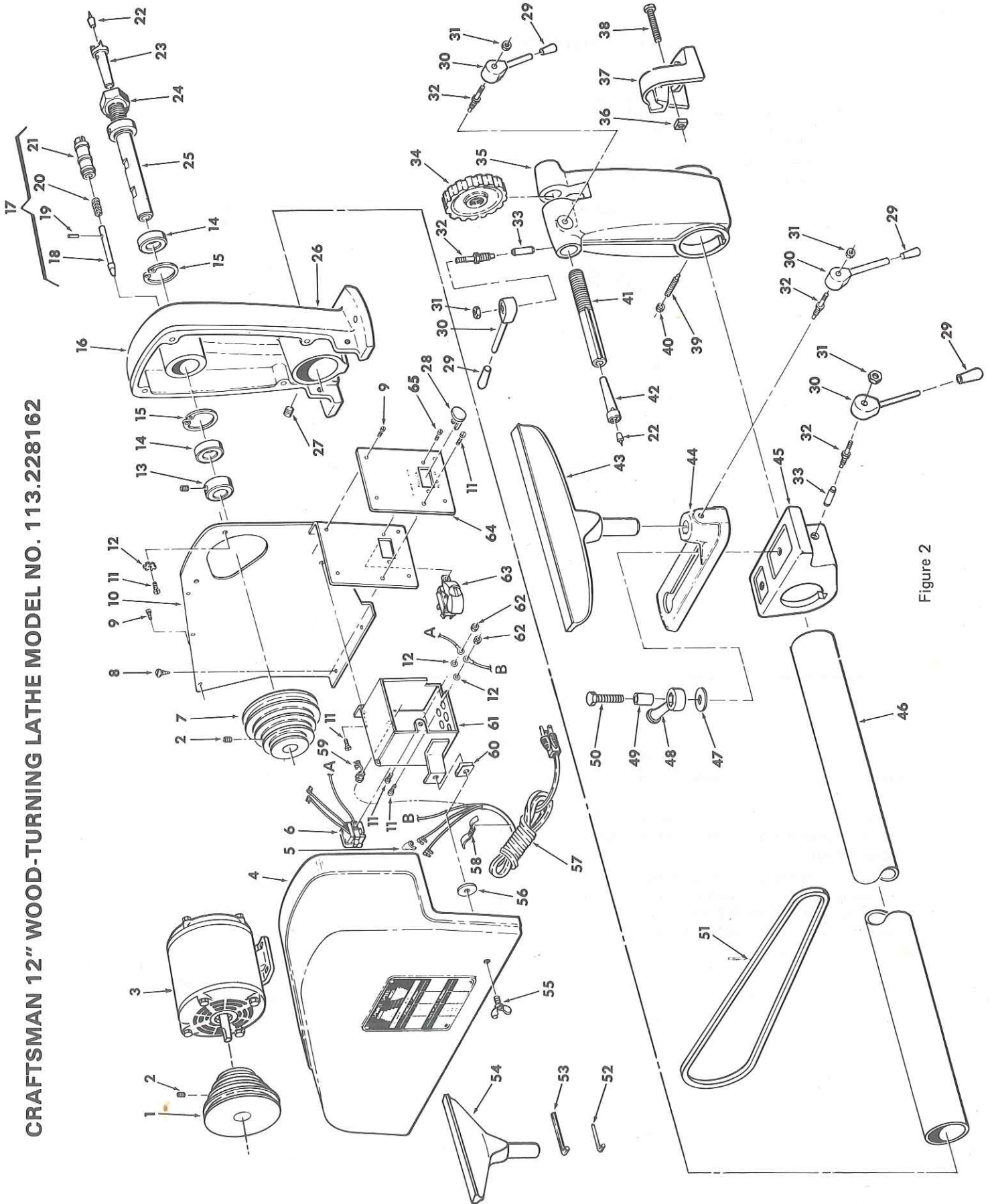

Figure 2

CRAFTSMAN 12" WOOD-TURNING LATHE MODEL NO. 113.228162

FIGURE 2

Key No.	Part No.	Description	Key No.	Part No.	Description
1	815252	+Pulley	34	56217	Wheel, Hand
2	STD 503102	*Screw, Soc. Hd. Set 5/16-18 x 5/16	35	70051	Housing, Tailstock
3	70055	Motor	36	120399	Nut Square 5/16-18 x 9/16 x 7/32
4	70004	Guard Assembly, includes items 55 and 56	37	56213	Foot, Rear
5	63467	Cap, Flag Term	38	805518	*Screw, Pan. Hd. 5/16-18 x 1-3/4
6	60341	Outlet	39	56628	Screw, Slotted Hd. Set 1/4-20 x 1-1/4
7	56170	Pulley, Includes Key No. 2	40	STD 541025	*Nut, Hex 1/4-20
8	STD 610805	*Screw, Pan Hd. Ty AB #8 x 1/2	41	56625	Spindle, Tailstock
9	STD 600603	*Screw, Pan Hd. Ty T 6-32 x 3/8	42	56190	+No. 1 Morse Taper Cut Center with Point
10	70008	Guard, Plate	43	70016	Rest, Tool
11	STD 601105	*Screw, Pan Hd. Ty T 10-32 x 1/2	44	56222	Holder, Tool Rest
12	STD 551210	*Lockwasher, No. 10	45	70049	Clamp, Support
13	56110	Collar with Set Screw	46	56130	Tube Assembly
14	18229	Bearing, Ball	47	60121	Washer, .380 x 1-9/64 x 7/64
15	38884	Ring, Retaining 1-5/8	48	69072	Wrench
16	70014	Headstock	49	69077	Spacer
17	56120	Plunger and Housing Assembly, Complete Consisting of Items 18, 19, 20, and 21	50	STD 523720	*Screw, Hex Hd. 3/8-16 x 2
18	56614	Plunger	51	STD 304370	*Belt, "Vee" 1/2 x 37
19	18994	Pin, Roll 3/32 x 1/2	52	60096	†Wrench, Hex 5/32
20	38896	Spring	53	30504	†Wrench, Hex 3/16
21	56613	Housing, Plunger	54	70019	Rest, 6" Tool
22	56619	Point	55	30540	Screw, Wing
23	56180	+No. 1 Morse Taper Spur Center with Point	56	805146	Washer, 7/32 x 1/2 x 1/16
24	219753	Nut, Hex 3/4-16	57	60271	Cord (w/Plug)
25	56611	Spindle	58	63418	Clamp
26	70006	Headstock Assembly, Complete Consisting of Items 14, 15, 16, 25, 13, 17, 7, 27, 22, 23	59	37818	Relief, Strain
27	STD 503705	*Screw, Soc. Hd. Set 3/8-16 x 1/2	60	37530	Nut, "U" Clip
28	60256	Key	61	70009	Box, Junction
29	60262	Grip	62	STD 541110	*Nut, Hex 10-32
30	70001	Lever, Assembly Lock	63	60267	Switch, Locking
31	STD 541425	Nut, Lock 1/4-20	64	70010	Switch, Panel
32	70052	Nut, Stud	65	STD 600605	*Screw, Pan Hd. Ty T 6-32 x 1/2
33	70050	Shoe, Lock	—	507458	Bag of Loose Parts (Not Illustrated)
			—	70057	Owners, Manual (Not Ills.)

* Standard Hardware Item — May Be Purchased Locally.

† Stock Item — May be secured through the Hardware Department of most Sears Retail Stores or Catalog Order Houses.

NOTE: Shipping and handling charges for standard hardware items (identified by *) such as nuts, screws, washers, etc., make buying these items by mail uneconomical. To avoid shipping and handling charges, you may obtain most of these locally.

SEARS

owners manual

SERVICE

**MODEL NO.
113.228162
LATHE WITH MOTOR**

**HOW TO ORDER
REPAIR PARTS**

12-INCH WOOD-TURNING LATHE

Now that you have purchased your 12" Wood-Turning Lathe should a need ever exist for repair parts or service, simply contact any Sears Service Center and most Sears, Roebuck and Co. stores. Be sure to provide all pertinent facts when you call or visit.

The model number of your 12" Wood-Turning Lathe will be found on a plate under the belt guard.

**WHEN ORDERING REPAIR PARTS, ALWAYS GIVE THE
FOLLOWING INFORMATION:**

PART NUMBER	PART DESCRIPTION
MODEL NUMBER 113.228162	NAME OF ITEM 12-INCH WOOD TURNING LATHE

All parts listed may be ordered from any Sears Service Center and most Sears stores. If the parts you need are not stocked locally, your order will be electronically transmitted to a Sears Repair Parts Distribution Center for handling.

Sold by SEARS, ROEBUCK AND CO., Chicago, IL. 60684 U.S.A.