



## SERVICE MANUAL

## MODEL VCR872

### CAUTION

Before servicing the chassis, read the "IMPORTANT SERVICE SAFETY INFORMATION" on the page 2 of this manual.

## HQ - HIGH QUALITY PICTURE VIDEO CASSETTE RECORDER



### SPECIFICATIONS

Power Source:	120V 60Hz
Power Consumption:	Approx. 28 W
Temperature:	5°C to 40°C
Television System:	USA 525 lines, 60 fields NTSC standard
Video Signal System:	NTSC type color signal
Video Recording System:	Luminance: FM azimuth recording color Phase shift & converted subcarrier direct recording
Scanning System:	Rotary, slant azimuth, 2 heads helical scanning system
Audio Track:	1 Track
Tape Width:	12.65 mm (1/2 inch)
Tape Speed:	SP: 33.35 mm/sec. LP: 16.7 mm/sec. EP: 11.12 mm/sec.
Visual Search Speed:	7 times
Record/Playback Time:	Max. 8 Hours T-160 at EP
FF/REW Time:	Less than 5.0 min, with T-120 tape
Heads:	Video: 2 rotary heads Audio/Control: 1 stationary head Erase: 1 full track erase
Modulator:	Signal Strength: 66 dB $\mu$ $\pm$ 3 dB 75 ohm Signal Frequency: 3 CH (61.25 MHz $\pm$ 50 KHz) or 4 CH (67.25 MHz $\pm$ 50 KHz)
Input Level:	Video: VIDEO IN Connector 1.0 Vp-p, 75 ohm, unbalanced Audio: LINE IN Jack -10 dB, 100k ohm, unbalanced
Output Level:	Video: VIDEO OUT Connector 1.0 Vp-p, 75 ohm, unbalanced Audio: LINE OUT Jack -8 dB, 600 ohm, unbalanced

# SERVICE PUBLICATION

# #53-86

## IMPORTANT SERVICE SAFETY INFORMATION

Safety precautions to be followed during servicing:

- 1) Parts marked with an  $\Delta$  are critical parts for safety. Replace only with the one described in parts list.
- 2) Before returning the TV receiver to the customer, make the appropriate leakage current or resistance measurements to ensure that exposed parts are properly insulated from the supply circuit.

Leakage current check is recommended for the following system. Plug the AC line cord directly into a 120V AC outlet (do not use an isolation transformer for this check). Use a leakage current tester (Fig. 1) or a metering system which complies with Underwriters Laboratories (UL 1409). Measure for current from all exposed metal parts of the cabinet to a known earth ground: particularly, any exposed metal part having a return path to the chassis. Any current measured must not exceed 0.5mA. Any measurement not within the limits outlined above are indicative of a potential shock hazard and corrective action must be taken before returning the unit to the customer.

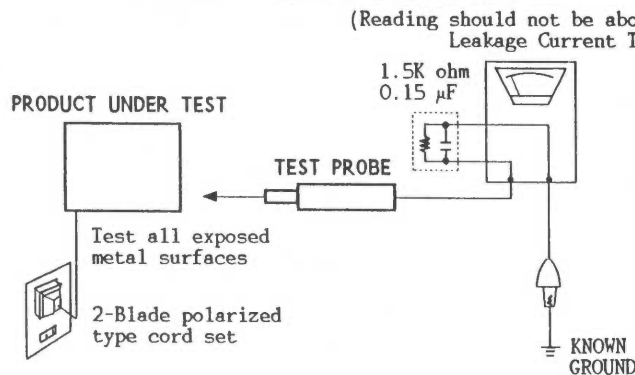

Fig.1 AC Leakage Test

## CONTENTS

	Page		Page
IMPORTANT SERVICE SAFETY INFORMATION .....	2	ELECTRICAL ADJUSTMENT	
KEY TO ABBREVIATIONS .....	3	■ E-12: E-E LEVEL ADJUSTMENT .....	18
SERVICING FIXTURES & TOOLS .....	3	■ E-17: RECORD CURRENT ADJUSTMENT .....	18
ALSO, LONG TERM STORAGE OR UNUSE MAY CAUSE		■ E-19: AUDIO BIAS CURRENT ADJUSTMENT .....	18
TRANSFORMATION AND AGING OF RUBBER PARTS .....	3	■ E-20: AUDIO PLAYBACK LEVEL ADJUSTMENT .....	19
DECK PARTS LOCATION .....	4	■ E-61: VIF ADJUSTMENT .....	19
INTERCHANGEABILITY METHODS AND ADJUSTMENT		■ E-62: AFT ADJUSTMENT .....	19
■ A-1: REPLACEMENT OF REEL DISK AND CONFIRMATION OF IIS		■ E-64: RF AGC ADJUSTMENT .....	20
HEIGHT .....	5	■ E-65: COLOR LEVEL ADJUSTMENT .....	20
■ A-2: HEIGHT CONFIRMATION AND ADJUSTMENT .....	6	■ E-66: CLOCK ADJUSTMENT .....	20
■ A-3: FAST FORWARD AND IIS TAKE-UP TORQUE		HOW TO RESET MICROCOMPUTER .....	20
CONFIRMATION .....	6	DISASSEMBLY INSTRUCTIONS .....	20, 21
■ A-4: REWIND AND IIS TAKE-UP TORQUE CONFIRMATION .....	7	MAJOR COMPONENTS LOCATION GUIDE .....	22
■ A-5: RECORD TAKE-UP TORQUE CONFIRMATION .....	7	BLOCK DIAGRAM	
■ A-6: CONFIRMATION OF FAST FORWARD BACK TENSION .....	7	TIMING CHART .....	23
■ A-7: CONFIRMATION OF REWIND .....	7	Y/C / HEAD AMP .....	24
■ A-8: CONFIRMATION OF SEARCH CUE BACK TENSION .....	7	OPERATION 1/2 .....	25
■ A-12: CONFIRMATION AND ADJUSTMENT OF TENSION POLE		SYSTEM CONTROL .....	26
POSITION .....	8	SERVO .....	27
■ A-14: CONFIRMATION AND ADJUSTMENT OF BACK TENSION OF		DEMODULATOR .....	28
RECORDING AND PLAYBACK .....	8	AUDIO / POWER SUPPLY .....	29
■ A-15: CONFIRMATION OF REEL BRAKE TORQUE .....	9	P.C. BOARD	
■ A-16: CONFIRMATION AND ADJUSTMENT FOR THE HEIGHT		MAIN / Y/C .....	30
OF P1 POST, P4 POST, LIMITER POST .....	10	OPERATION 1/2 / HEAD AMP / POWER SUPPLY / ANTENNA ...	31
■ A-17: REPLACEMENT OF A/C HEAD .....	10	SCHEMATIC DIAGRAM	
■ A-18: CONFIRMATION AND ADJUSTMENT OF A/C HEAD HEIGHT		OPERATION 1/2 .....	32
AND TILT .....	11	AUDIO .....	33
■ A-19: TAPE RUNNING ADJUSTMENT .....	11	SYSTEM CONTROL .....	34
■ A-20: REPLACEMENT OF UPPER DRUM .....	12	SERVO .....	35
■ A-21: ADJUSTMENT OF GUIDE ROLLER .....	12	DEMODULATOR .....	36
■ A-26: REPLACEMENT OF CYLINDER UNIT .....	13	Y/C .....	37
■ A-27: REPLACEMENT OF TENSION BAND ASS'Y .....	13	Y/C / HEAD AMP .....	38
■ A-34: REPLACEMENT OF LOADING BELT .....	14	POWER SUPPLY .....	39
■ A-35: REPLACEMENT OF BELT REEL .....	15	INTERCONNECTION .....	40
■ A-36: REPLACEMENT OF PINCH ROLLER .....	15	MECHANICAL EXPLODED VIEW .....	41
■ A-37: REPLACEMENT OF DD UNIT .....	15	DECK EXPLODED VIEW .....	42, 43
■ A-38: REPLACEMENT OF LOADING MOTOR .....	16	ELECTRICAL REPLACEMENT PARTS LIST .....	44~46
ELECTRICAL ADJUSTMENT		DECK REPLACEMENT PARTS LIST .....	47
■ E-4: P.G. SHIFTER ADJUSTMENT .....	17	MECHANICAL REPLACEMENT PARTS LIST .....	48
■ E-6: TRACKING FIX ADJUSTMENT .....	17	INTERCHANGEABLE PARTS LIST .....	48









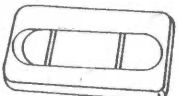

### HQ FEATURE

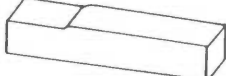
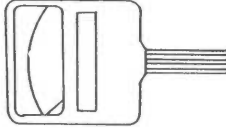
This video cassette recorder marked "HQ" incorporates VHS high quality picture technology. A built-in detail enhancer is used to boost the recorded signal and provide maximum picture quality in playback. It is compatible with other VHS video cassette recorders.

# KEY TO ABBREVIATIONS

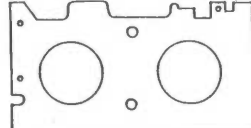
<b>A</b>	AC	: Alternating Current
	A/C	: Audio/Control
	ACC	: Automatic Color Control
	A/E	: Audio/Erase
	AFC	: Automatic Frequency Control
	AFT	: Automatic Fine Tuning
	AGC	: Automatic Gain Control
	ALREC	: All Recording
	ALC	: Automatic Level Control
	AMP	: Amplifier
	APC	: Automatic Phase Control
	AT	: All Time
<b>B</b>	BOT	: Beginning of Tape
	BPF	: Band-Pass Filter
	B/W	: Black and White
<b>C</b>	CA	: Clutch Actuator
	CAP	: Capstan
	CASS.	: Cassette
	C.C.W.	: Counter Clockwise
	CH	: Channel
	COU.	: Counter
	CTL	: Control
	CURR	: Current
	CYL	: Cylinder
<b>D</b>	DC	: Direct Current
	DD Unit	: Direct Drive Motor Unit
	DET	: Detector
	DEV	: Deviation
	D-V.SYNC	: Dummy-Vertical Synchronization
	D/W	: Dark/White
<b>E</b>	E-E	: Electric to Electric
	EF	: Emitter Follower
	EOT	: End of Tape
	EP	: Extended Play
	EQ	: Equalizer
	EXT	: External
<b>F</b>	FF	: Flip Flop or Fast Forward
	FG	: Frequency Generator
	FH	: Frequency Horizontal
	F.LDM	: Front Loading Motor
	FM	: Frequency Modulation
	FSC	: Frequency Sub Carrier
	FWD	: Forward
<b>G</b>	GND	: Ground
<b>H</b>	HPF	: High-pass Filter
	H.SW	: Head Switch
<b>I</b>	IF	: Intermediate Frequency
	IND	: Indicator
	INV	: Inverter
<b>L</b>	LIMT	: Limiter
	LP	: Long Play
	LPF	: Low-pass Filter
<b>M</b>	ME.STO.	: Memory Stop
	MID	: Middle
	MIN	: Minimum
	MIX	: Mixer, Mixing
	M.M.	: Mono Multi
	MMV	: Mono Multi Vibrator
	MOD	: Modulation, Modulator
<b>O</b>	OSC	: Oscillator
<b>P</b>	PB	: Playback
	PB-C	: Playback-Chrominance
	PB-Y	: Playback-Luminance
	PC	: Phase Compensator
	PCB	: Printed Circuit Board
	P.CON	: Power Control
	PG	: Pulse Generator
	P/S	: Pause/Still
	PWM	: Pulse Width Modulation
<b>R</b>	REC	: Recording
	REC-C	: Recording-Chrominance
	REC-Y	: Recording-Luminance
	REW	: Rewind
	REG	: Regulated, Regulator
	RF	: Radio Frequency
	RVS	: Reverse
	REW	: Rewind
<b>S</b>	SEL	: Select, Selector
	S/H	: Sample and Hold
	SS	: Supply Sub Brake
	SW	: Switch
	SW.P	: Switching Pulse
<b>T</b>	TB	: Take Up Back Tension Brake
	T.LDM	: Tape Loading Motor
	TIM./SL.	: Timer/Sleep
	TRK.	: Tracking
	TS	: Take-up Sub Brake
	TSD	: Terminal Shut Down
	TP	: Test Point
<b>V</b>	VCO	: Voltage Controlled Oscillator
	VD	: Vertical Drive
	V/F	: Video Intermediate Frequency
	VR	: Variable Resistor
	V/S	: Visual/Search
	V-SYNC	: Vertical-Synchronization
<b>Y</b>	YCA	: Luminance Chrominance Audio

# SERVICING FIXTURES AND TOOLS

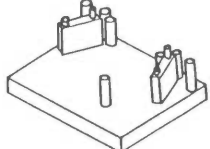
JG001 VHS Alignment Tape 	JG005 Post Adjustment Screwdriver 	JG026 Post Adjustment Chip 
Back Tension Meter (Tentelometer, Made in U.S.A.) 	JG021 X-Nut Adjustment Screwdriver 	JG027 Playback Tension Torque Gauge 
JG002D Dial Torque Gauge (300~2400g) JG002E (10~90g) JG002G (100~1200g) 	JG022 Master Plane 	JG032 Adjustment Screwdriver 
JG004 Fine Adjustment Screwdriver 	JG024 Reel Table Height Chip 	JG034 Post Stopper Fixing Jig 

## ALSO, LONG TERM STORAGE OR UNUSE MAY CAUSE TRANSFORMATION AND AGING OF RUBBER PARTS

The following standard table depends on environmental condition and usage. And unless the maintenance service is properly carried out, the following intervals may be quite shortened and also a harmful effect may be had on the other parts. The long term safekeeping and unuse of the sort of rubber cause transformation and aging of it.

Parts Name	Time	500	1,000	1,500	2,000	3,000	Notes
	hours	hours	hours	hours	hours	hours	
Head, Full Erase		<input type="checkbox"/>	<input type="checkbox"/>	<input type="checkbox"/>	<input type="checkbox"/>	<input type="checkbox"/>	Clean those parts in contact with the tape.
Head, Audio Control		<input type="checkbox"/>	<input type="checkbox"/>	<input type="checkbox"/>	<input type="checkbox"/>	<input type="checkbox"/>	
Belt, Loading			<input type="checkbox"/>		<input type="checkbox"/>		Clean the rubber, and part which the rubber touches.
Belt, Reel			<input type="checkbox"/>		<input type="checkbox"/>		
Pinch Roller		<input type="checkbox"/>	<input type="checkbox"/>	<input type="checkbox"/>	<input type="checkbox"/>	<input type="checkbox"/>	
Capstan DD Unit						<input type="checkbox"/>	
Motor, Loading						<input type="checkbox"/>	
Tension Band Ass'y						<input type="checkbox"/>	
Capstan Shaft		<input type="checkbox"/>	<input type="checkbox"/>	<input type="checkbox"/>	<input type="checkbox"/>	<input type="checkbox"/>	
Impedance Roller		<input type="checkbox"/>	<input type="checkbox"/>	<input type="checkbox"/>	<input type="checkbox"/>	<input type="checkbox"/>	Need to replace when rolling comes to be abnormal.
Tape Running Guide Post		<input type="checkbox"/>	<input type="checkbox"/>	<input type="checkbox"/>	<input type="checkbox"/>	<input type="checkbox"/>	
Unit, Cylinder		<input type="checkbox"/>	<input type="checkbox"/>	<input type="checkbox"/>	<input type="checkbox"/>	<input type="checkbox"/>	Clean the upper drum (especially the video heads) in the direction of drum rotation using a thick, textured cloth. Avoid wiping vertically as this may cause damage to the video heads.

○ : Replace    □ : Clean

# DECK PARTS LOCATION

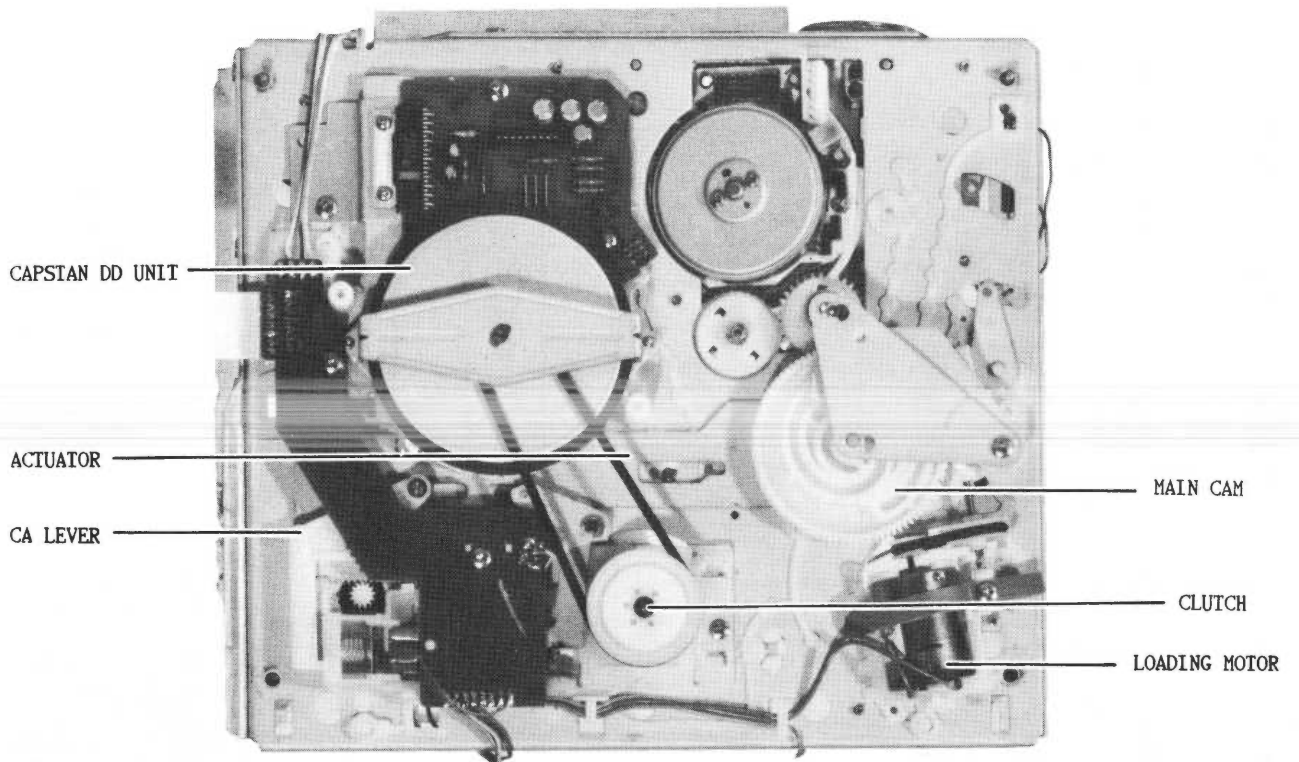
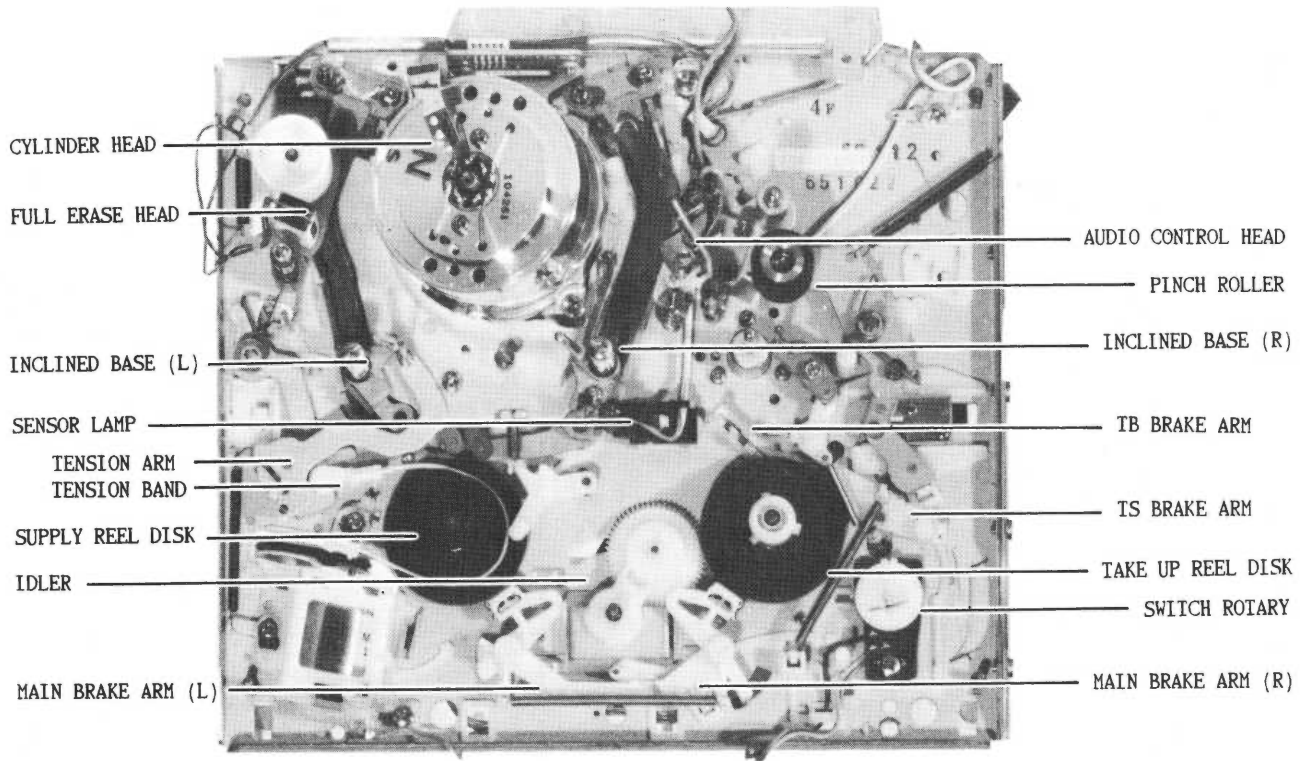

# INTERCHANGEABILITY METHODS AND ADJUSTMENT

## ● PRECAUTION

○ Remove the following items before adjusting the Deck and then start working.

1. Top Cabinet (2 screws)
2. Bottom Plate (6 screws)
3. Front Panel
4. Shield Plate (3 screws)
5. Stage  
(Refer to stage removal and installation)

Carefully read each item in ●NOTE sections before starting work.

To operate Deck with stage removed from the unit.

- \* Short the Cassette In Switch Terminal with the Deck Chassis.
- \* Place an object which weighs between 350g and 500g on the Video Tape to keep it steady while using the Video Cassette Tape. (Do not place an object which weighs over 500g.)

## HOW TO REMOVE AND INSTALL STAGE

### ● REMOVAL

1. Disconnect the 8th pin connector (CP1001), which has been connected to the stage PCB, from the system control PCB.
2. Remove 2 screws fixed to inside panel.
3. Remove 2 screws (Tapping (Bo) 3x10, Red) while stage is locked when power switch is OFF.
4. Push the stage toward arrow mark, and lift up to remove the stage.

### ● NOTE

1. When you remove and install stage, be careful it does not touch guide pin or cylinder head.
2. Be careful not to break connectors or cut leads.

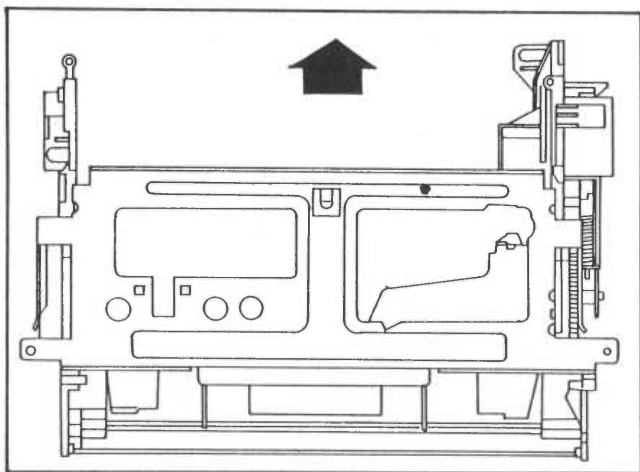

## HOW TO INSTALL

1. Set the stage and fix with 2 screws (Tapping (Bo) 3x10, Red).
2. Fix 2 screws to inside panel.
3. Connect 8th pin connector (CP1001), which comes from stage, to system control PCB.

## ● NOTE AFTER INSTALLATION

1. Check the following:

- a. Make sure that the Front Loading Operation works well when turning on the power and when inserting a cassette pack into the stage.
- b. If it begins play mode after Play Button is pushed.
- c. If it begins recording mode after Recording Button is pushed.
- d. If it ejects after Eject Button is pushed.

## ● NOTE

1. Under this operation system, end sensor and start sensor are opened. So auto rewind at the time of tape end will not work.
2. When you want to make tape run without stage, use an object which weighs approximately 500g.

## ■ A-1: REPLACEMENT OF REEL DISK AND CONFIRMATION OF ITS HEIGHT

### ● REMOVAL

(Supply Reel Disk)

1. Remove the SS Brake Spring from the Loading Base.
2. Remove the SS Brake.
3. Remove tension band.
4. Remove polyslider washer ①.
5. Separate mechanical brake from reel disk.
6. Pull supply reel disk ③ upward and replace it.

(Take-up Reel Disk)

1. Remove the TB Brake.
2. Remove polyslider washer ①.
3. Separate mechanical brake from reel disk.
4. Pull take-up reel disk ④ upward and replace it.

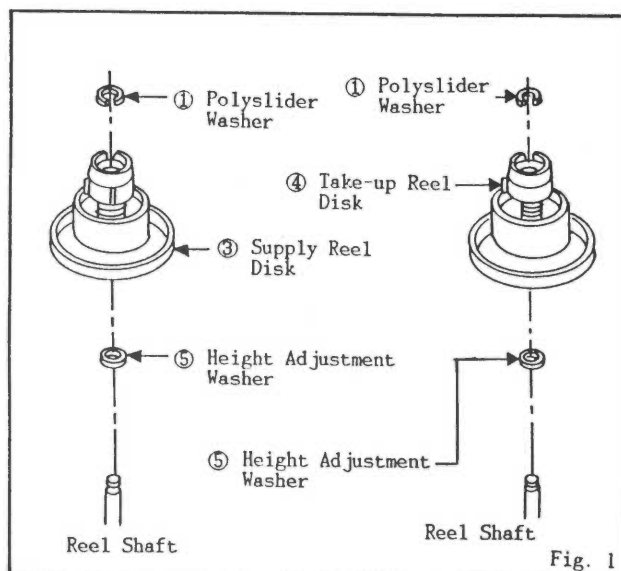

Fig. 1

● **INSTALLATION**

(Supply Reel Disk)

1. Clean reel disk shaft and put in height adjusting washer ⑤.
2. Attach new supply reel disk.
3. Make height adjustment of reel disk using master plane (JG022) and reel table height chip (JG024).
4. Pull out new supply reel disk. After oiling (Maruzen Oil Swafuld No.100) on reel disk shaft, attach the new supply reel disk again.
5. Attach polyslider washer ①.
6. Attach tension band.
7. Install the SS Brake in the chassis.
8. Install the Spring in the Loading Base.

(Take-up Reel Disk)

1. Clean reel disk shaft and put in height adjusting washer ⑤.
2. Attach new take-up reel disk.
3. Make height adjustment of reel disk using master plane (JG022) and reel table height chip (JG024).
4. Pull out new reel take-up disk. After oiling (Maruzen Oil Swafuld No.100) on reel disk shaft, attach the new take-up reel support again.
5. Attach polyslider washer ①.
6. Install the take-up side (IS) Brake.

● **NOTE**

1. Make height adjustment of reel disk after replacement.
2. Be careful not to deform tension band at the time of removal and attachment.
3. Be careful not to deform IS Brake.
4. Be careful not to scratch reel disk shaft by polyslider washer or tool at the time of removal and attachment.
5. After installation adjust the tension post position and tape tension when playing back in accordance with ■A-7.
6. Refer to ■A-2 for reel disk height adjustment.

■ **A-2: HEIGHT CONFIRMATION AND ADJUSTMENT**

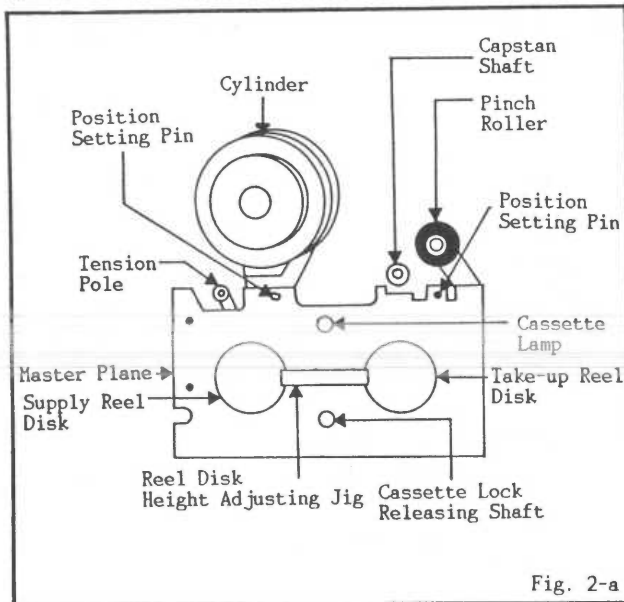

Fig. 2-a

● **ADJUSTMENT**

1. Set master plane (JG022) at mechanism framework, taking care not to scratch drum, as shown in Fig. 2-a.

2. Confirm that the master plane (JG022) sits between A and B, as shown in Fig. 2-b, using reel table height chip (JG024). In case it is beyond the range of set-up value, adjust it by height adjusting washer, making up-down play within 0.1~0.5mm.

● **NOTE**

1. Use same thickness adjustment washer (REF#521) as found in unit.

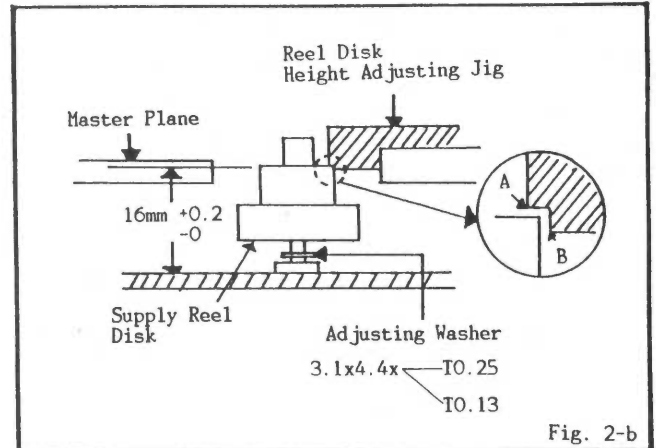

Fig. 2-b

"NOTE: Refer to the table below for possible cause of problems when confirmation cannot be made for the indicated items."

CONFIRMATION ITEM	CHECK POINT (REPLACEMENT)
A-3 A-4 A-5 A-7	Capstan belt may be stretched clutch may be worn out (if so, change reel disk) Idler Ass'y may be worn out.
A-6 A-8	Tension band may be worn out.
A-15	Main brake belt may be worn out.

**LIST OF CONFIRMATION ITEM:**

- A-3 Fast forward and its take-up torque confirmation
- A-4 Rewind and its take-up torque confirmation
- A-5 Record take-up torque confirmation
- A-6 Confirmation of fast forward back tension
- A-7 Confirmation of rewind
- A-8 Confirmation of search cue back tension
- A-15 Confirmation of reel brake torque

■ **A-3: FAST FORWARD AND ITS TAKE-UP TORQUE CONFIRMATION**

● **CONFIRMATION**

1. Set torque gauge (JG002D) on take-up reel disk, and place unit in fast forward mode.
2. Confirm that torque is more than 800g.cm.

● **NOTE**

1. Hold the torque gauge (JG002D) in place when you push Fast Forward Button and reel disk begins to turn, after setting torque gauge (JG002D) on the reel disk.
2. Carry out this confirmation and adjustment without using video cassette tape.

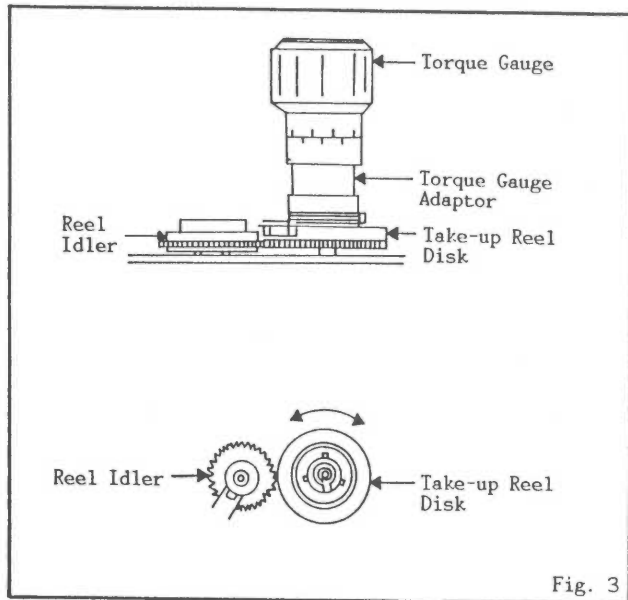

Fig. 3

■ A-4: REWIND AND ITS TAKE-UP TORQUE CONFIRMATION

● CONFIRMATION

1. Set torque gauge (JG002D) on supply reel disk, and place unit in rewinding mode.
2. Confirm that torque is more than 800g.cm.

● NOTE

1. Hold the torque gauge (JG002D) in place when you push the Rewind Button, and reel disk begins to turn, after setting torque gauge (JG002D) on the reel disk.
2. Carry out this confirmation and adjustment without using video cassette tape.

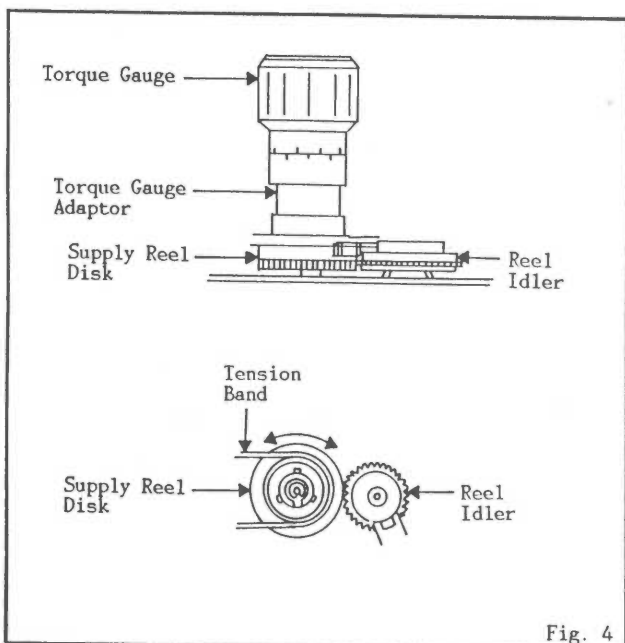

Fig. 4

■ A-5: RECORD TAKE-UP TORQUE CONFIRMATION

● CONFIRMATION

1. Set torque gauge (JG027) on the rewind reel disk, then check REC mode.
2. Select both SP and EP modes with the speed select switch, then make sure that the torque covers the following range.

SP MODE: 100~230g.cm (confirm)  
EP MODE: 90~200g.cm (confirm)

■ A-6: CONFIRMATION OF FAST FORWARD BACK TENSION

● CONFIRMATION

1. Set the unit in fast forward mode by pushing Fast Forward Button.
2. Put torque gauge (JG002E) on supply reel disk and make slow right turn (one turn in a few seconds). And confirm torque is within set-up value (15~35g.cm).

● NOTE

1. Put torque gauge (JG002E) on reel disk steadily and measure.

■ A-7: CONFIRMATION OF REWIND

● CONFIRMATION

1. Set the unit in rewind mode by pushing Rewind Button.
2. Put torque gauge (JG002E) on take-up reel disk and make slow left turn (one turn in a few seconds) and confirm torque is within set value (30~60g.cm).

● NOTE

1. Put torque gauge (JG002E) on reel disk steadily and measure.

■ A-8: CONFIRMATION OF SEARCH CUE BACK TENSION

● CONFIRMATION

1. Set the unit in play mode by pushing Play Button.
2. Push search Cue Button and the unit will be in search cue mode. Confirm SS brake is working on supply reel disk.
3. Put torque gauge (JG002E) on supply reel disk and make slow right turn (one turn in a few seconds). Measure torque of this and confirm it satisfies set-up point (above 90g.cm).

● NOTE

1. After positioning tension arm, conduct confirmation and adjustment of visual search cue back tension.
2. Put torque gauge (JG002E) on reel disk steadily and measure. In case torque gauge is playing, correct measurement will not be done.

■ A-9, 10, 11: NOT REQUIRED FOR THIS MODEL

■ **A-12: CONFIRMATION AND ADJUSTMENT OF TENSION POLE POSITION**

● **CONFIRMATION**

1. Load the T-120 tape, and press the PLAY button to set the playback mode.
2. As soon as guide rollers, L, R begin to draw tape from cassette, tension pole shall move to the left, thus loading will start. Confirm tension pole position at this stage.
3. When the tape (T-120) is near the beginning, confirm by eye that the center of tension pole is positioned 4.5~6.5mm to the left from center of P1 post.
4. Confirm that video tape is not curling at flange of P1 post or is not running on flanges.

● **POSITIONING**

1. In case tension pole is positioned to the left of center of P1 Post by less than 4.5mm, move tension band adjustment angle ① to direction of arrow B (Fig. 12-a), then screw ② shall be tightened.
2. In case tension pole is positioned on the left of center of P1 post by more than 6.5mm, move tension band adjustment angle ① to direction of arrow A (Fig. 12-b), then screw ② shall be tightened.

● **NOTE**

1. After completion of positioning, do not forget to fix the position with paint.
2. Do not overtighten screw, otherwise threads may be damaged.

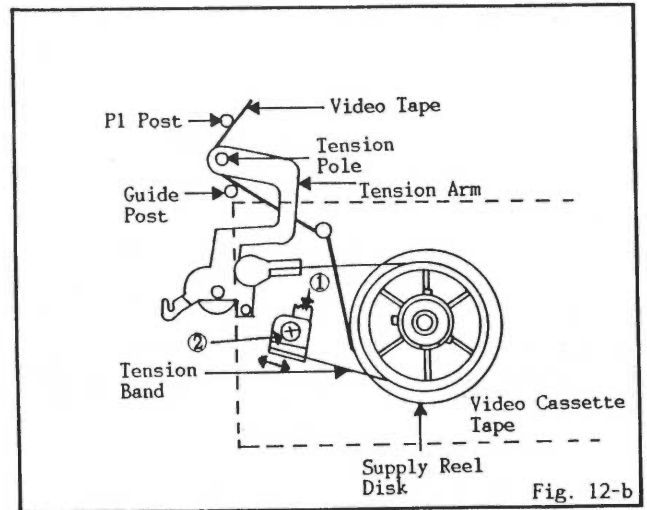
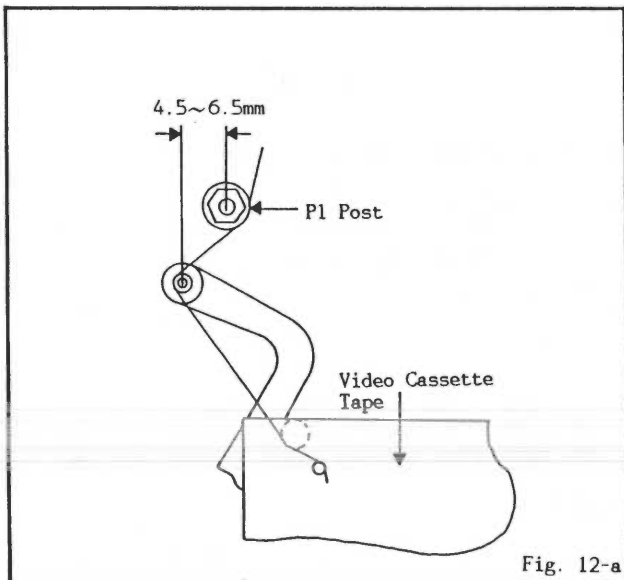

■ **A-13: NOT REQUIRED FOR THIS MODEL**

■ **A-14: CONFIRMATION AND ADJUSTMENT OF BACK TENSION OF RECORDING AND PLAYBACK**

● **CONFIRMATION**

- When you use back tension measuring cassette.
1. Set the measuring cassette tape.
  2. Set the unit in recording mode. At this time, confirm, by pointer of the measuring cassette tape, that back tension is within set-up points (20~50g.cm).
  3. Confirm video tape is tightly running on fixed guide.
  4. At beginning and ending of tape, confirm there is no sag or damage on edge of tape.

- When you use tentelometer.
1. Set T-120 cassette tape to the beginning.
  2. Set the unit in recording mode.
  3. Pull Impedance roller toward arrow A as in Fig. 14-a and set tentelometer as in Fig. 14-a, 14-b confirming tape tension is within set-up points (23~30g).
  4. Confirm video tape is running tight on P1 post.
  5. Confirm there is no sag or damage on edge of tape both in beginning and ending of tape.

● **ADJUSTMENT**

1. In case tape tension is weaker than 23g, adjust tension plate on arrow A side of Fig. 14-c and reconfirm the tension.
2. In case tape tension is stronger than 30g, adjust tension plate on arrow B side of Fig. 14-c and reconfirm the tension. (Use adjusting screwdriver, JG032)

● NOTE

1. The tentelometer should not touch F/E Head, drum or other component where tape may go over it.
2. When you use the back tension measuring cassette, it is recommended to also use tentelometer for proofreading.
3. Use lock paint after adjustment.
4. Do not overtighten screw, otherwise the threads will be broken.

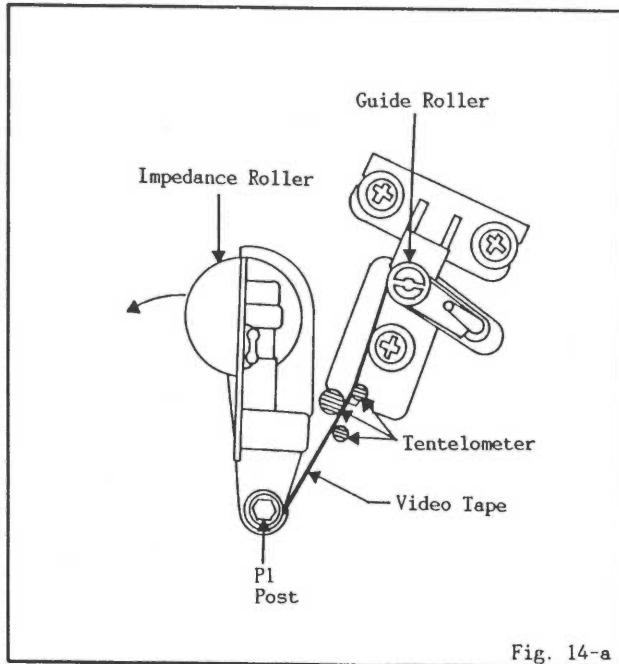

Fig. 14-a

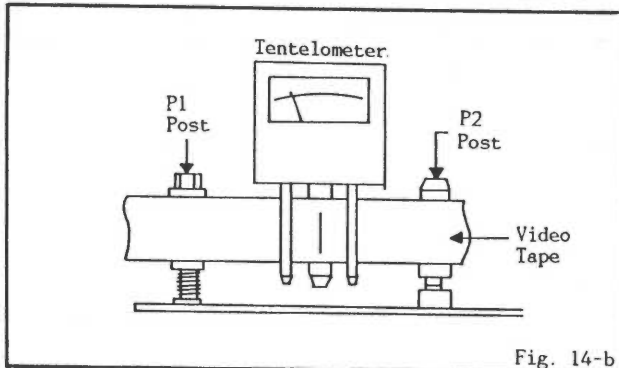

Fig. 14-b

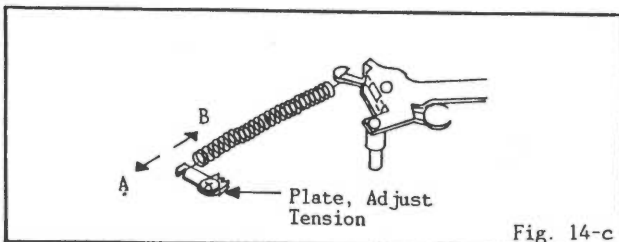

Fig. 14-c

■ **A-15: CONFIRMATION OF REEL BRAKE TORQUE**

■ **A-15-1: Confirmation of take-up reel brake**

● CONFIRMATION

1. Set the stop mode.
2. Set the torque gauge (JG002G) to the take-up reel and turn it counter-clockwise. Confirm that the brake torque is more than 250g.cm. Refer to Fig. 15-a.

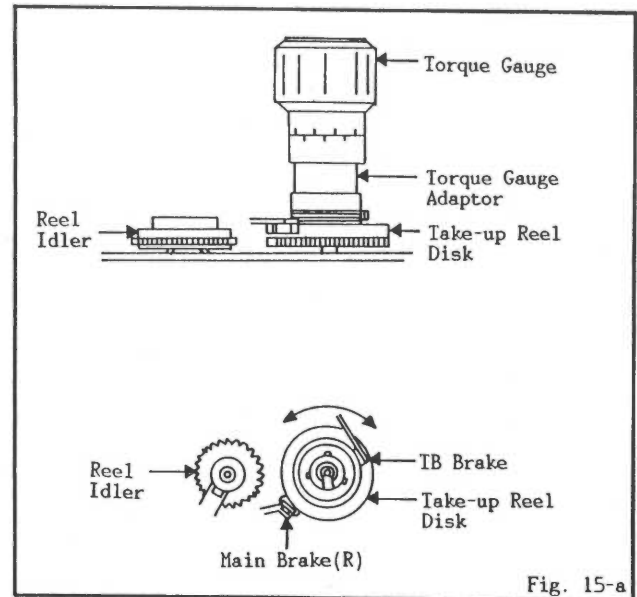

Fig. 15-a

■ **A-15-2: Confirmation of supply reel brake**

● CONFIRMATION

1. Set the stop mode.
2. Set the torque gauge (JG002G) to the supply reel and turn it clockwise. Confirm that the brake torque is more than 250g.cm. Refer to Fig. 15-b.

● NOTE

1. Separate the idler from the reel and confirm the brake.

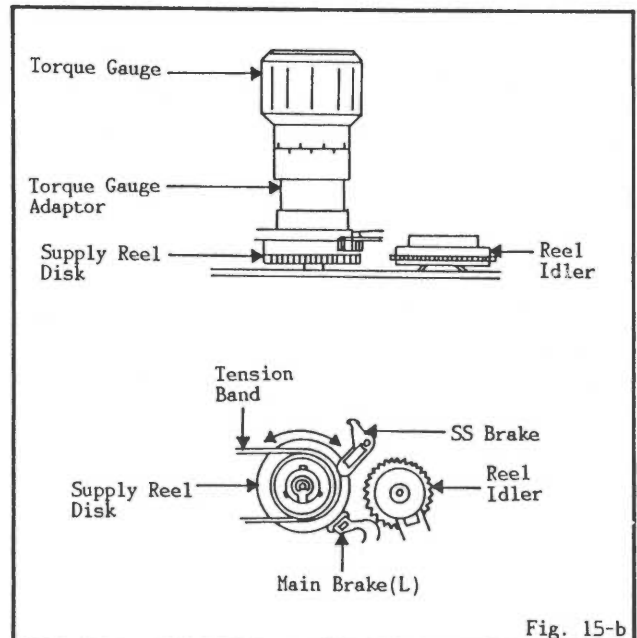

Fig. 15-b

■ **A-16: CONFIRMATION AND ADJUSTMENT FOR THE HEIGHT OF P1 POST, P4 POST, LIMITER POST**

● **CONFIRMATION**

1. Confirm that when tape is running there is no crease or bend on tape edge at the places shown in Fig. 16-a.

■ **A-16-1: Confirmation and adjustment for the height of P1 post**

● **ADJUSTMENT**

1. Set the master plane (JG022) to the Deck.
2. Put the Post Adjustment Tip (JG026) on the master plane (JG022), adjust the height by sliding the A part of Post Adjustment Tip (JG026) to the "a" direction of the master plane (JG022). Refer to Fig. 16-b, c.

■ **A-16-2: Confirmation and adjustment for the height of P4 post.**

● **ADJUSTMENT**

1. Set the master plane (JG022) to the Deck.
2. Put the Post Adjustment Tip (JG026) on the master plane (JG022), adjust the height by sliding the A part of Post Adjustment Tip (JG026) to the "b" direction of the master plane (JG022). Refer to Fig. 16-b, c.

■ **A-16-3: Confirmation and adjustment for the height of limiter post**

● **ADJUSTMENT**

1. Set the master plane (JG022) to the Deck.
2. Put the Post Adjustment Tip (JG026) on the master plane (JG022), adjust the height by sliding the A part of Post Adjustment Tip (JG026) to the "c" direction of the master plane (JG022). Refer to Fig. 16-b, c.

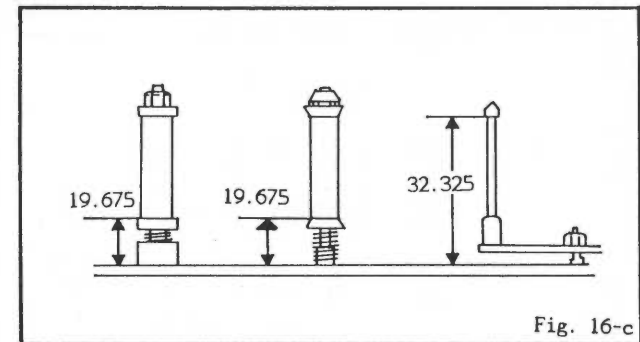
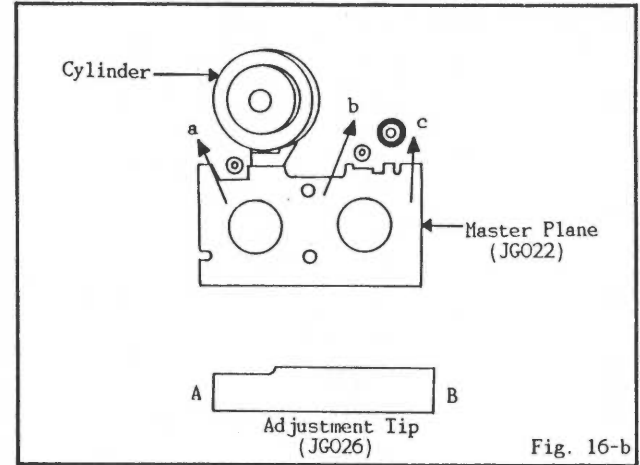
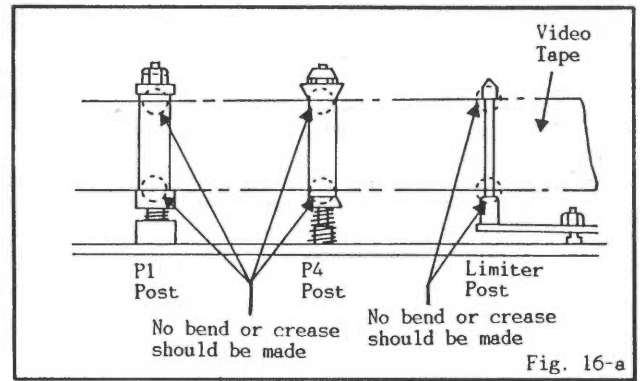

● **NOTE**

1. The following adjustment must be carried out only when height is not correct.
2. After adjustment, check it with video tape running condition.
3. After completion of adjustment, carry out tape running adjustment. After adjusting guide roller (L, R), check as shown in Fig. 16-a.
4. Do not move nut after completion of adjustment.
5. After completing of adjustment, always fix P1 post and guide roller with screw lock.

■ **A-17: REPLACEMENT OF A/C HEAD**

● **REPLACEMENT**

1. Remove solder from lead wires placed on A/C Head P.C.Board, and take lead wires away from P.C.Board.
2. Loosen set screw ③ using (JG008C). (Fig. 17-a)
3. Remove screw ④ using plus(+) driver.
4. Remove A/C Head screw ⑥ using plus(+) driver. Carefully do this, because there is a spring between plate and A/C Head screw.

● **NOTE**

1. After completion of replacement, do not fail to carry out tape running adjustment. Do not touch head by any means when replacing A/C Head.

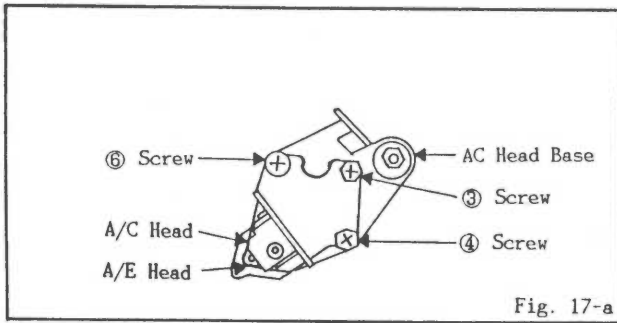

Fig. 17-a

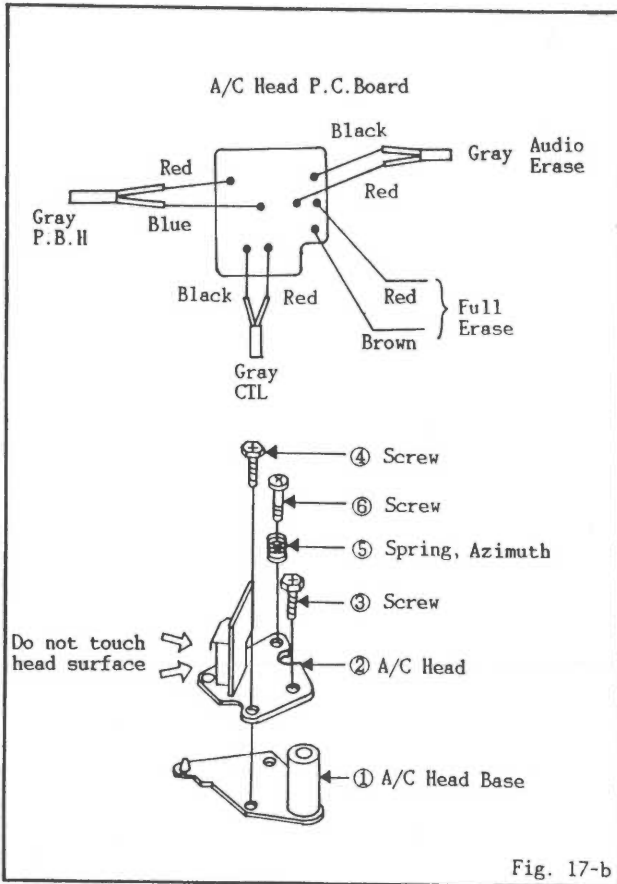

Fig. 17-b

■ A-18: CONFIRMATION AND ADJUSTMENT OF A/C HEAD HEIGHT AND TILT

● CONFIRMATION

1. Set the unit in play mode using a T-120 tape.
2. Confirm that tape is not curling on flange of guide post.
3. Confirm that height and tilt of A/C Head against tape are as per Fig. 18.

● ADJUSTMENT

In case tape is running abnormally, make the following adjustments (Fig. 17-a and 18).

1. Check tape running condition with the unit in play mode using the T-120 tape.
2. Confirm tape runs smoothly without any crease or bend between guide post and guide roller R
3. It is absolutely impossible to get satisfactory sound if tape is distorted between A/C Head and guide post. So confirm there is no crease on the tape.

4. In case tape is not in good condition, adjust it by turning screw ③ slowly.  
NOTE: Do not move guide post.

5. Height of A/C Head against tape should be as per Fig. 18.

If tape runs smoothly around A/C Head and rough adjustment of height is done, carry out height and azimuth adjustment of A/C Head using linear tape (JG001).

1. Play back audio tone 6KHz (picture is B/W Pattern) linear tape (JG001) and observe the waveform at Audio output terminal with oscilloscope.
2. Turn set screw ④ slowly until maximum level is reached. When the level becomes maximum, set screws where level variation is the smallest. (Fig. 17-a)
3. Re-check tape running adjustment. (■ A-19)

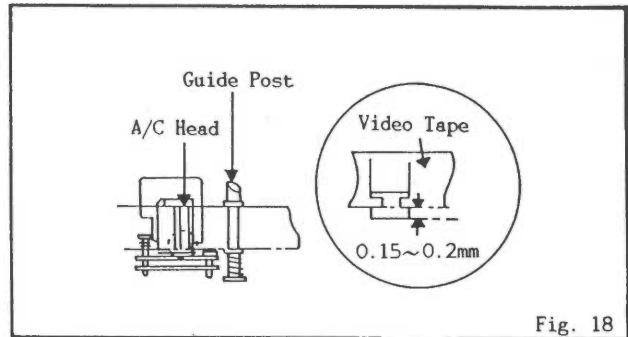

Fig. 18

■ A-19: TAPE RUNNING ADJUSTMENT

● ADJUSTMENT

1. Carry out reel disk height adjustment using master plane (JG022) and reel table height chip (JG024).
2. Carry out height confirmation and adjustment of P1 post and guide post using fixed jig (JG029B) in accordance with paragraph ■ A-16.
3. In accordance with ■ A-12 and ■ A-13, carry out positioning and confirm that the tension pole is with the tension pole positioning jig (JG029B).
4. Play back the rough adjustment tape and make rough adjustment of guide roller height with the tool (JG021) according to ■ A-21 and then, match lower edge of tape to drum lead and make sure that video tape does not curl on flange of the guide post.
5. In accordance with ■ A-21, play the linear tape and adjust guide roller height so that envelope becomes flat and that flatness will not be affected even when the tracking control knob is turned.
6. In accordance with ■ A-18, adjust A/C Head height, tilt and azimuth.
7. Position tracking control knob at preset and turn adjusting nut X a little as in Fig. 17-a so that envelope becomes maximum. Adjust position of A/C Head.
8. To confirm the flatness of envelope and voice recording, use the output from an appropriate test signal.
9. After completion of adjustment, fix each adjustment screw and nut etc.

## ■ A-20: REPLACEMENT OF UPPER DRUM

### ● REPLACEMENT

1. Remove 2 screws (Tap Tite(S) 3x6 Bind ⑦, Tap Tite(S) 3x10 Bind ⑧) fixed the Head Amp, then pull out the Head Amp from the cylinder.
2. Remove the screw ⑥ which fixes the brush ⑤.
3. Disconnect lead wires ① (two, yellow).
4. Disconnect lead wire ② (one, red).
5. Disconnect lead wire ③ (one, brown).
6. Remove two fixing screws with flat washers ④ using plus(+) driver.
7. Pull out upper drum in such a way that it will not incline upward and carefully replace in order not to scratch disk.

### ● INSTALLATION

1. Set up new drum as per Fig. 20 and correctly place each lead wire.
2. Fix upper drum by two fixing screws ④.
3. Solder lead wires ①, ② and ③ to their respective positions.
4. Fix Video Head lead wire press plate ⑤ by fixing screws ⑥, install carefully.
5. Fix the Head Amp with 2 screws ⑦, ⑧ again.

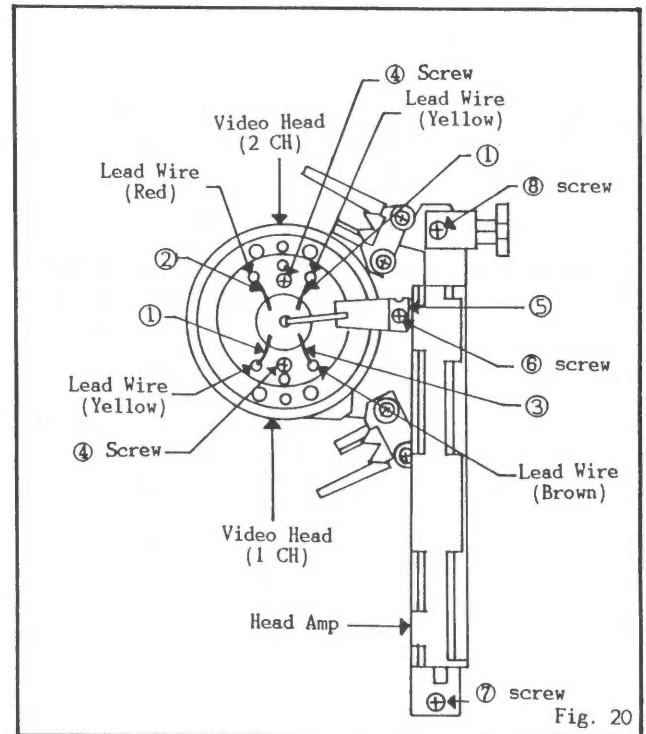

### ● NOTE

1. Fitting clearance between disk outer diameter and drum inner diameter is made in micron order. Scratches and dust can make them hard to fit or to separate them and can adversely affect fitness of the drum and disk. Pay attention.
2. Do not touch head on drum surface directly.
3. Do not apply excessive pressure to screwdriver.
4. Unless you have tool (JG031), use gloves.
5. Connect to yellow, brown lead (CH-1) and red, yellow lead (CH-2).
6. Before installing, confirm that there is no scratch or dust on disk front and surface.
7. Before installing, confirm that there is no scratch or dust on inside of upper drum and surface.
8. When installing, place upper drum slowly and carefully so that it will not scratch disk.
9. When setting, take care not to let any dust or dirt go into the clearance between disk and upper drum.
10. Turn fixing screws slowly and carefully.
11. After completion of replacement, do not forget to carry out tape running adjustment and do the following electrical adjustment and confirmations.
  - a. ■ E-4: P.G. Shifter Adjustment
  - b. ■ E-6: Tracking Fix Adjustment
  - c. ■ A-21: Guide Roller Adjustment

## ■ A-21: ADJUSTMENT OF GUIDE ROLLER

### ● ADJUSTMENT

1. Insert linear tape into stage.
2. Switch on main power and then connect monitor output cord and video input cord to proper positions.
3. Connect CH-1 and CH-2 of oscilloscope to envelope output and to test point of switching pulse, respectively.
4. Carry out this adjustment in playback mode.
5. Trigger with SW pulse and observe envelope. (Fig. 21-a)
6. Observe the envelope, adjust guide roller height and let tape run on drum head. If video tape is running above or below helical lead position, waveform shall appear as in Fig. 21-b and 21-c.
7. Adjust guide roller height while observing the envelope, and make envelope flat. Adjust the envelope so that the flatness will not be affected even when the tracking control knob is turned.
8. When the tracking control knob is turned, adjust envelope so that its A:B ratio is better than 10:7 at where waveform starts to reduce at A. (Fig. 21-d)
9. Make adjustment of ■ E-4 P.G. shifter point as per play SW point of electrical adjustment.
10. Record color bar and playback, to confirm envelope is flat.
11. After that, carry out confirmation of envelope.

### ● NOTE

1. In case the guide roller has been adjusted, work ● ADJUSTMENT in ■ A-18 again.

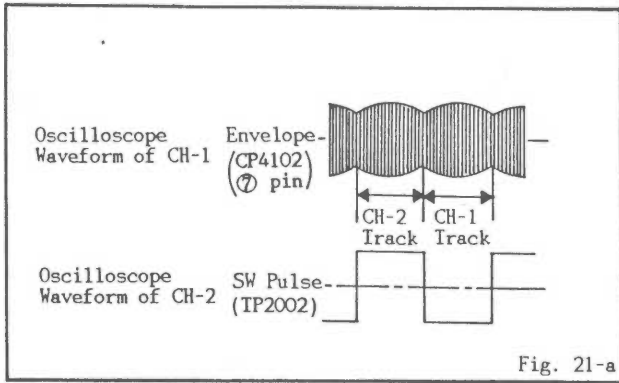

a: Envelope waveform will appear like Fig. 21-b when video tape is above the helical lead position.

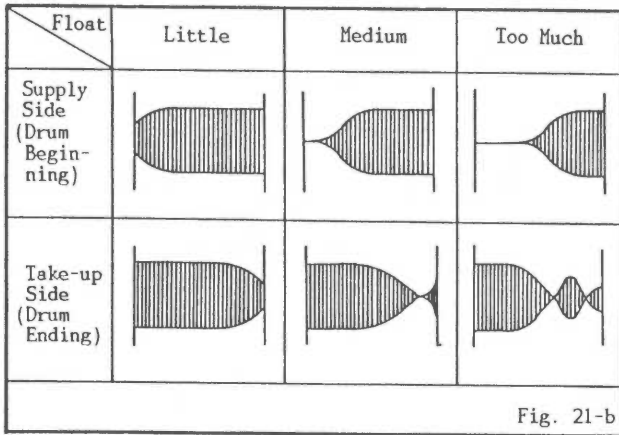

Fig. 21-b

b: Envelope waveform will appear like Fig. 21-c when video tape is lower than helical lead position.

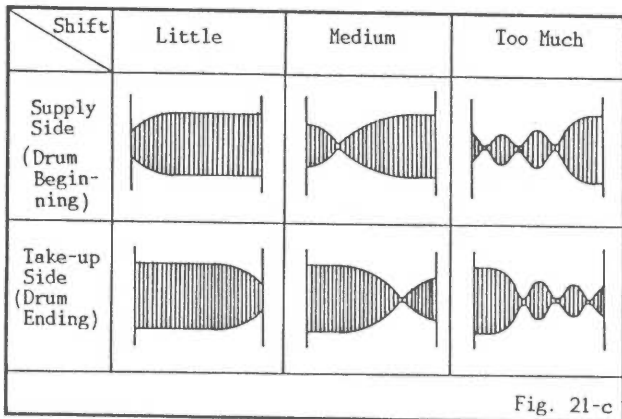

Fig. 21-c

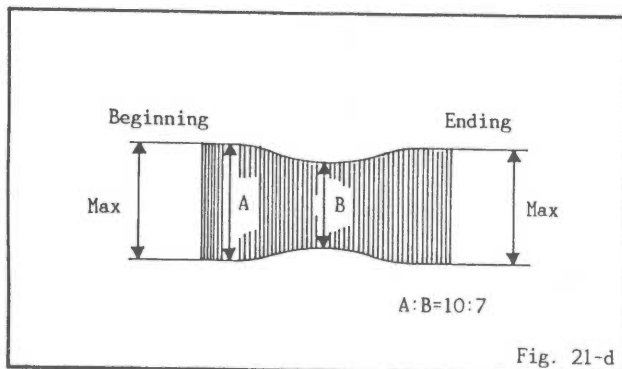

Fig. 21-d

■ A-22~25: NOT REQUIRED FOR THIS MODEL

## ■ A-26: REPLACEMENT OF CYLINDER UNIT

### ● REMOVAL

1. Remove 2 screws (Tap Tite(S) 3x6 Bind ③, Tap Tite(S) 3x10 Bind ④) fixed the Head Amp, then pull out the Head Amp from the cylinder.
2. Remove the video head shield plate in the video base plate to disconnect the video head lead connector.
3. Disconnect the connector on the cylinder base plate.
4. Disconnect the heater lead connector on the cylinder from the relay base plate.
5. Remove cylinder unit by taking out screws ① and ②. (Fig. 26)

### ● INSTALLATION

1. Fix the post stopper to the cylinder base with the post stopper fixing jig (JG034).
2. Fix new cylinder unit in reverse of removal.
3. Fix the Head Amp with 2 screws ③, ④ again.

### ● NOTE

1. Do not touch the surface of the cylinder head.
2. Make sure of ■ A-20.

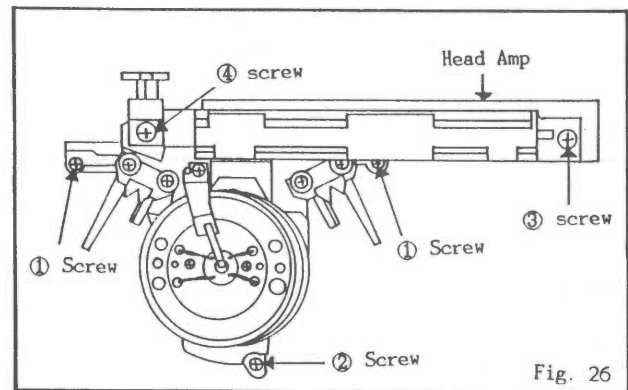

Fig. 26

## ■ A-27: REPLACEMENT OF TENSION BAND ASS'Y

### ● REMOVAL

1. Remove screw ① fixed to the tension band.
2. Release SS brake from the tension band to remove it from the Supply Reel Disk. (Fig. 27)
3. Remove the tension band from tension arm.

### ● INSTALLATION

1. Fix new cylinder unit in reverse of removal.

### ● NOTE

1. The tension band should not be twisted while installing it.
2. Adjust the placement of the tension post according to item ■ A-12.
3. After adjustment of the above 2, adjust it according to item ■ A-14.

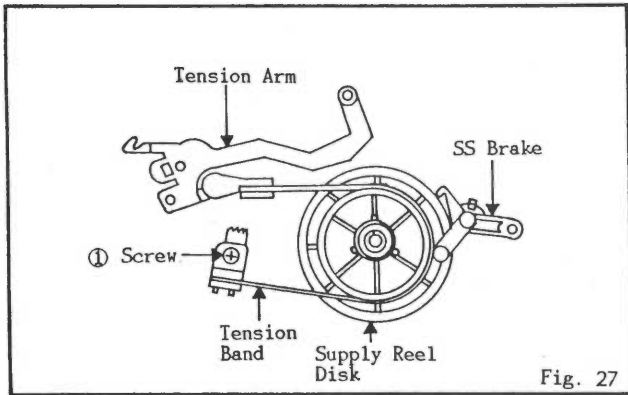

Fig. 27

■ A-28~33: NOT REQUIRED FOR THIS MODEL

### ■ A-34: REPLACEMENT OF LOADING BELT

#### ● REMOVAL

1. Remove screw ① fixed to the FS Gear Plate.
2. Remove the FS Gear Plate, the Polyslider Washer ② and the Fan Shaped Gear. (Fig. 34-a)
3. Remove screw ③ fixed to the Loading Motor Band to take it off. (Fig. 34-b)
4. Remove 2 pieces of stoppers ④, then pull the hook ⑤ in the direction of the arrow to remove the Loading Motor. (Fig. 34-b)
5. Remove the Loading Belt from the Loading Motor.
6. Move the Tension Lever 1 to the dotted line. (Fig. 34-a)
7. Remove the Main Cam.
8. Remove the Worm Ass'y and replace Loading Belt with new one.

#### ● INSTALLATION

1. Hang new Loading Belt on the pulley of the Worm Ass'y, then hang it on the pulley of the Loading Motor.
2. First, attach Loading Motor, next fix the Worm Ass'y.
3. Fix the Main Cam.
4. Fix the Tension Lever 1.
5. Fix the Fan Shaped Gear.
6. Fit the FS Gear Plate, then fix screw ①.
7. Fix the Loading Motor Band with screw ②.

#### ● NOTE

1. Clean the pulley when replacing Loading Belt.
2. Exchange it in stop mode.
3. Avoid sticking grease to the Loading Belt.
4. Do not mistake the point (A, D, E) of the Main Cam, the Tension Lever 1 and the Fan Shaped Gear. (Fig. 34-a, b, c)
5. Make sure that A point is within B range in fixing of the Main Cam. (Fig. 34-c)
6. Make sure that D part is within C part in fixing of the Tension Lever 1. (Fig. 34-a, c)
7. Make sure that E part is within C part in fixing of the Fan Shaped Gear. (Fig. 34-a, c)

#### ● CHECK AFTER INSTALLATION

1. Check if strange sound is made in play mode.
2. Check if P2 post and P3 post are fitted to the post stopper.
3. Check if P2 post and P3 post are completely returned in stop mode.

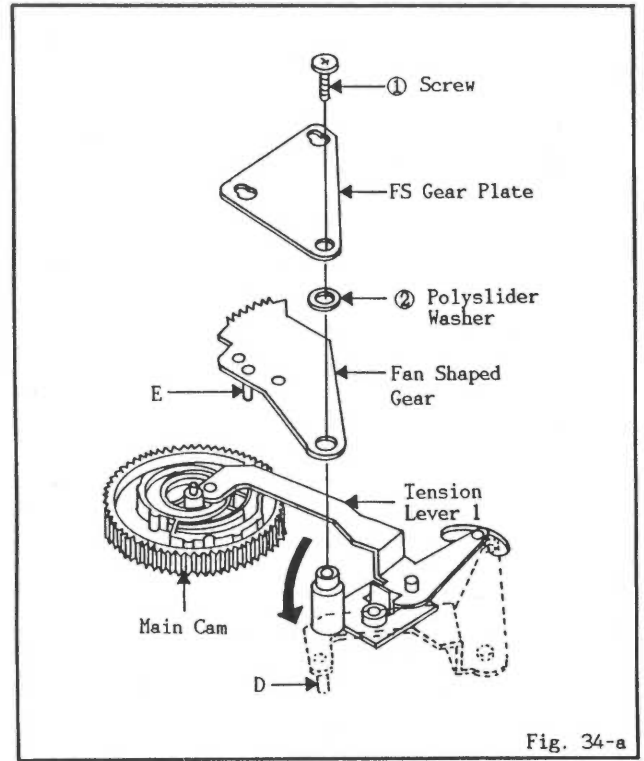

Fig. 34-a

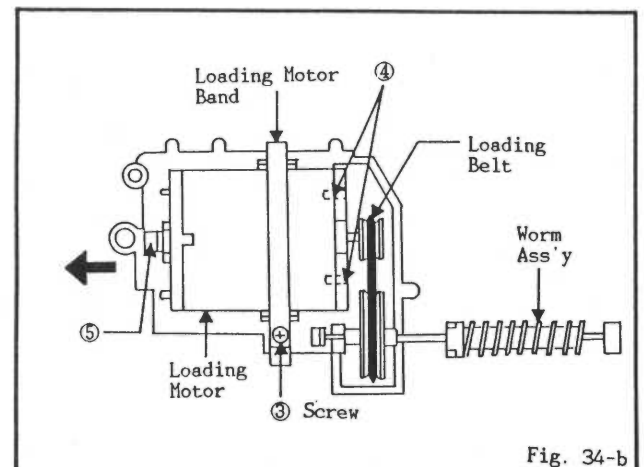

Fig. 34-b

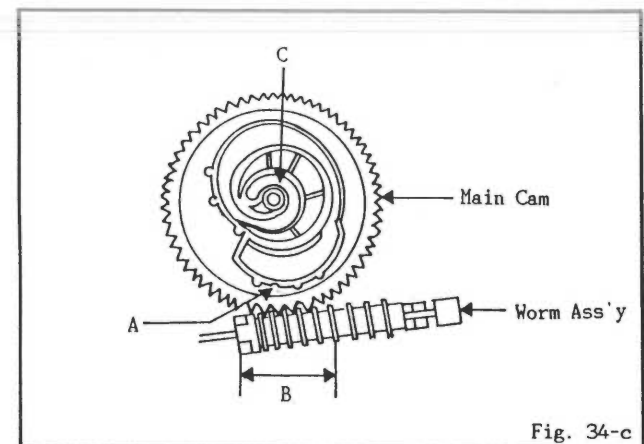

Fig. 34-c

### ■ A-35: REPLACEMENT OF BELT REEL

#### ● REMOVAL

1. Remove 2 screws ① to take off the DD unit and its plate. (Fig. 35)
2. Remove the Belt Reel.

#### ● INSTALLATION

1. Clean the DD unit Pulley ② and the Clutch Pulley ③, then fix them to the pulley without making the Belt dirty.
2. Fix the DD unit and its plate with 2 screws ①.

#### ● NOTE

1. Avoid sticking grease to the Loading Belt.
2. The driver and the plate should not touch around the FLYWHEEL of the DD unit.

#### ● CHECK AFTER INSTALLATION

1. Check if REW/FF mode works normally.
2. Check if PLAY mode works normally.

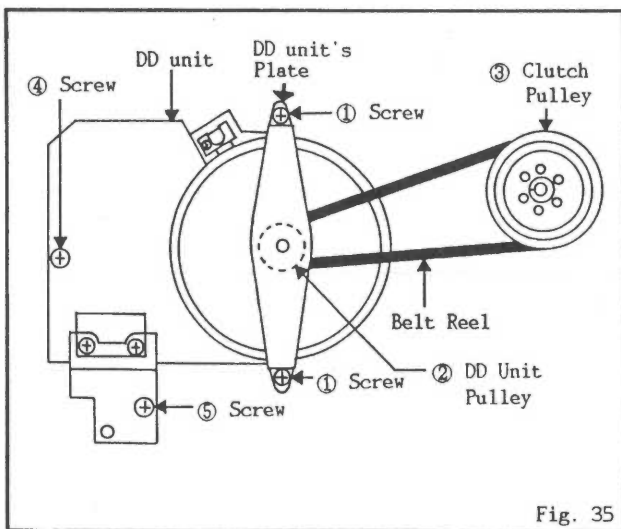

Fig. 35

### ■ A-36: REPLACEMENT OF PINCH ROLLER

#### ● REMOVAL

1. Remove screw ①. (Fig. 36)
2. Remove the Pinch Roller.

#### ● INSTALLATION

1. Fix new Pinch Roller in reverse order of removal.

#### ● NOTE

1. Be careful of bending the Pinch Roller Arm in removal and installation.
2. Do not touch around the Pinch Roller.

#### ● CHECK AFTER INSTALLATION

1. Check if the tape is running normally in play mode.

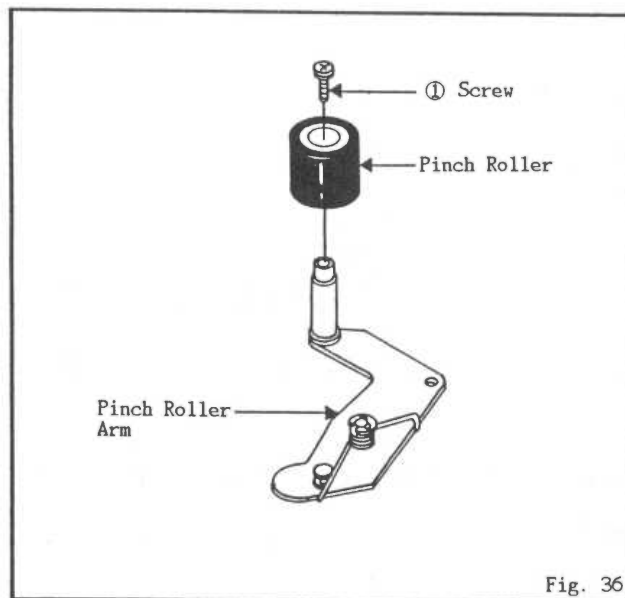

Fig. 36

### ■ A-37: REPLACEMENT OF DD UNIT

#### ● REMOVAL

1. Remove the Deck unit from the Inside Cabinet.
2. Remove 3 screws ① (SEMS A 2.6x6) fixed to DD unit on front of the Deck. (Fig. 37)
3. Turn the Deck over, then remove the Reel Belt from the clutch pulley.
4. Remove screw ④ (TAP TITE(S) BIND 3x10) and screw ⑤ (TAP TITE(S) BIND 3x6) fixed to the DD unit PCB. (Fig. 35)
5. Remove the DD unit slowly from rear side of the Deck.

#### ● INSTALLATION

1. Return the Limiter Post to dotted line, then fit new DD unit to the chassis without touching center of the shaft of the DD unit to the chassis. And return the Limiter Post to where it was. (Fig. 37)
2. Fix screw ④ (TAP TITE(S) BIND 3x10) and screw ⑤ (TAP TITE(S) BIND 3x6) fixed to the DD unit PCB. (Fig. 35)
3. Fix the clutch pulley without twisting the Reel Belt.

#### ● NOTE

1. Do not bend the Limiter Post.
2. Use the specified screw fixed to the DD unit.
3. Tighten the screws completely.

#### ● CHECK AFTER INSTALLATION

1. Check if tape running is normal in PLAY mode.
2. Check if FF/REW mode is normally worked.

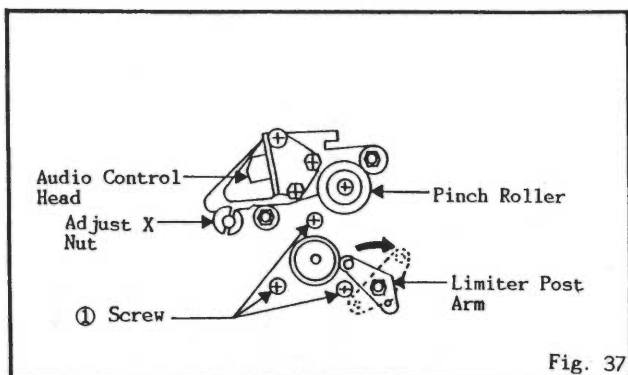

Fig. 37

### ■ A-38: REPLACEMENT OF LOADING MOTOR

#### ● REMOVAL

1. Remove screw ③ fixed to the Loading Motor Band.
2. Remove 2 stoppers ④, then pull the hook ⑤ in the direction of the arrow to take off the Loading Motor. (Fig. 34-b)
3. Remove the Loading Belt from the Loading Motor.

#### ● INSTALLATION

1. Fix new Loading Motor in reverse of removal.

#### ● NOTE

1. Make sure to wire the lead.

www.servicemanuals.net  
 10 North Main St.  
 Wharton, NJ 07885

## ELECTRICAL ADJUSTMENT

Remove the following parts before operating electric adjustment.

1. Top Cabinet (2 screws)
2. Bottom Plate (6 screws)

Prepare the following measurement tools for the electrical adjustment.

1. Oscilloscope
2. AC Voltmeter
3. Quartz Timer
4. Sweep-Marker Generator
5. AFT Adjustment Oscillator
6. Synchro Scope
7. VIF Unit
8. Voltmeter

Fix up in reverse order of removal after adjustment

### ADJUSTMENT SPECIFICATION

#### ADJUSTMENT PROCEDURE

■ E-1~3: NOT REQUIRED FOR THIS MODEL

■ E-4: P.G. SHIFTER ADJUSTMENT

#### CONDITIONS

MODE - PLAY

Input signal - Standard tape

NOTE: Tracking control should be set at click point.

#### INSTRUCTIONS

- (1) Connect CH-1 on oscilloscope to TP2001 and connect CH-2 on Video Out terminal.
- (2) Adjust VR2001 so that waveform of oscilloscope may become  $5.5 \pm 0.5(H)$  at both leading and trailing edges as Fig. 4-a, b.

#### CHART/CHARACTERISTICS

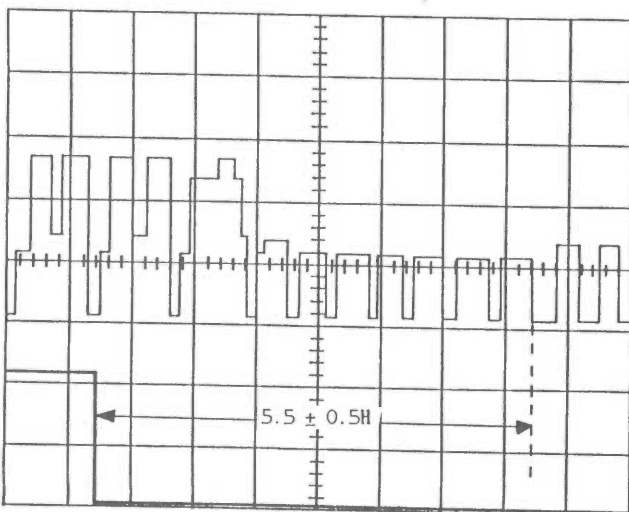

Fig. 4-a

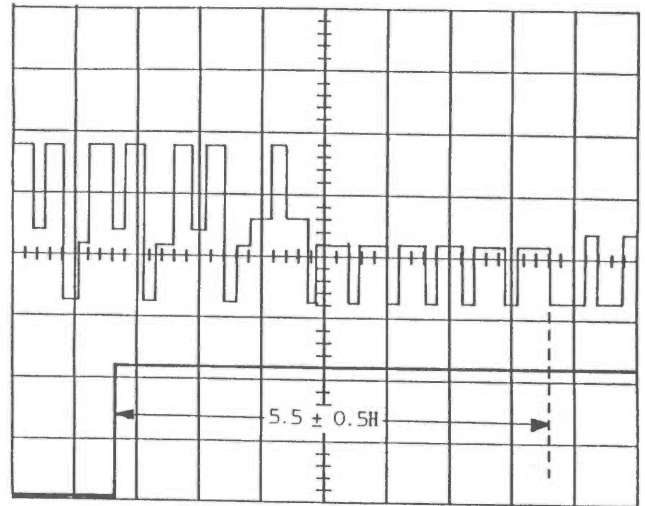

Fig. 4-b

■ E-5: NOT REQUIRED FOR THIS MODEL

■ E-6: TRACKING FIX ADJUSTMENT

#### CONDITIONS

MODE - PLAY

Input signal - Standard tape

NOTE: Tracking control should be set at click point.

#### INSTRUCTIONS

- (1) Connect CH-1 on oscilloscope to TP2001 and connect CH-2 on oscilloscope to TP2002.
- (2) Playback the recorded portion and adjust VR2002 so that "T" portion may become  $2.8 \pm 0.2V$  as Fig. 6.

#### CHART/CHARACTERISTICS

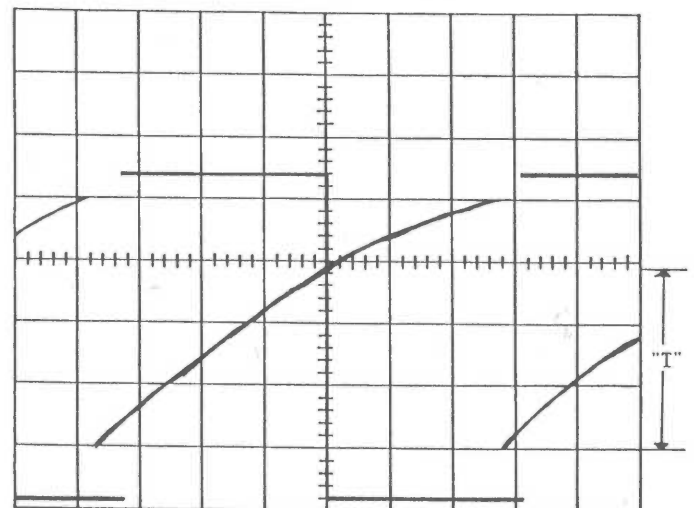

Fig. 6

■ E-7~11: NOT REQUIRED FOR THIS MODEL

■ E-12: E-E LEVEL ADJUSTMENT

CONDITIONS

MODE - STOP  
Input signal - Color bar

NOTE: Video out of the unit should be terminated with 75 ohm load.

INSTRUCTIONS

- (1) Connect oscilloscope to TP4202.
- (2) Adjust VR4001 so that waveform may become  $1.0 \pm 0.05V_{p-p}$  as Fig. 12.

CHART/CHARACTERISTICS

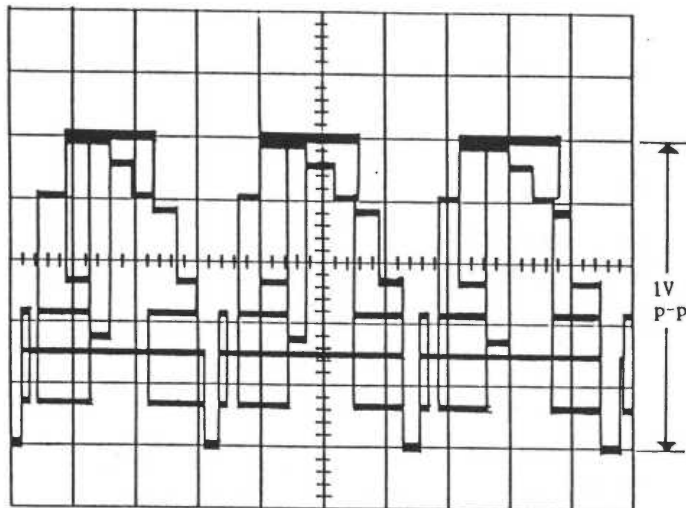

200mV 20  $\mu$ s/div  
Fig. 12

■ E-13~16: NOT REQUIRED FOR THIS MODEL

■ E-17: RECORD CURRENT ADJUSTMENT

CONDITIONS

MODE - RECORD  
Input signal - Color bar

INSTRUCTIONS

- (1) Connect CH-1 of oscilloscope to Video Out terminal and CH-2 to TP4101. Reduce brightness signal factors by turning VR4102 fully counter-clockwise.
- (2) Adjust VR4101 so that cyan level may become  $30 \pm 2mV_{p-p}$  as Fig. 17-a.
- (3) Adjust VR4102 so that horizontal sync. level may become  $140 \pm 5mV_{p-p}$ , as Fig. 17-b.

CHART/CHARACTERISTICS

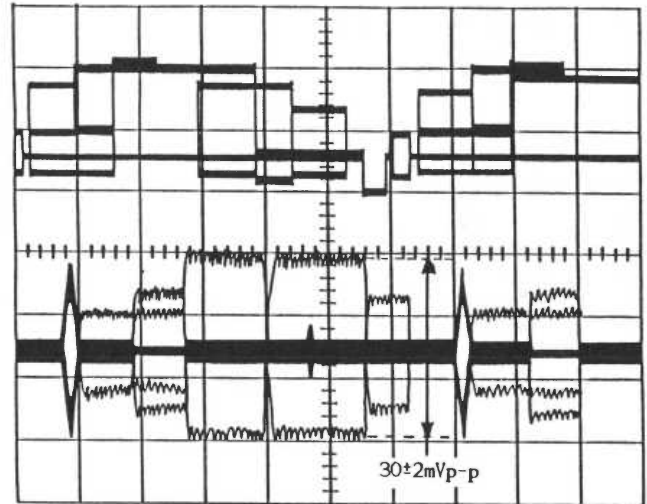

10mV 10  $\mu$ s/div  
Fig. 17-a

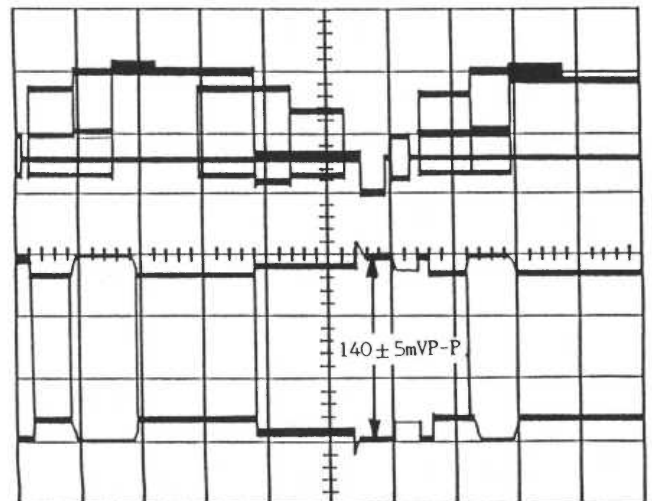

50mV 10  $\mu$ s/div  
Fig. 17-b

■ E-18: NOT REQUIRED FOR THIS MODEL

■ E-19: AUDIO BIAS CURRENT ADJUSTMENT

CONDITIONS

MODE - RECORD  
Input signal - No signal

INSTRUCTIONS

- (1) Remove the shield plate.
- (2) Connect AC voltmeter to both ends of 10 ohm resistor. Adjust VR5002 so that voltage may become  $3.0 \pm 0.1mV_{rms}$ .
- (3) After adjustment, lift up the shield plate.

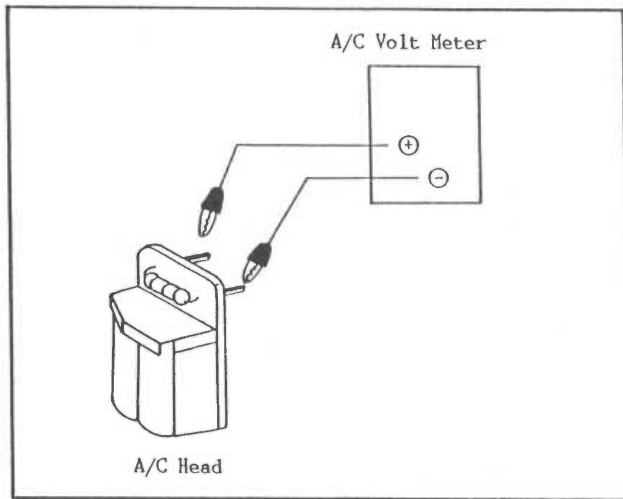

Fig. 19

### ■ E-20: AUDIO PLAYBACK LEVEL ADJUSTMENT

#### CONDITIONS

MODE - Self - record and playback  
 Input signal - 1KHz 300Vrms, Audio signal  
 Color bar, Video signal.

#### INSTRUCTIONS

- (1) Connect AC voltmeter to audio out jack, which is terminated with 47K ohm resistor.
- (2) Record and then playback the audio signal so specified.
- (3) Adjust VR5001 so that the playback output may become  $380 \pm 20\text{mVrms}$ .

### ■ E-21~60: NOT REQUIRED FOR THIS MODEL

### ■ E-61: VIF ADJUSTMENT

#### CONDITIONS

- (1) Connect the AGC volume to TP6010 (+12V), TP6007 and TP6002 (GND).
- (2) Terminate TP6004 and TP6005 to 100 ohm.

#### INSTRUCTIONS

- (1) Connect the output of Sweep-Marker Generator to TP6006.
- (2) Adjust L6010 so that output waveform of TP6003 may become as shown in Fig. 61-a.
- (3) Connect the output of Sweep-Marker Generator to the Tuner Pack IP.
- (4) Make sure that the output of waveform of TP6003 is as shown in Fig. 61-b.

## CHART/CHARACTERISTICS

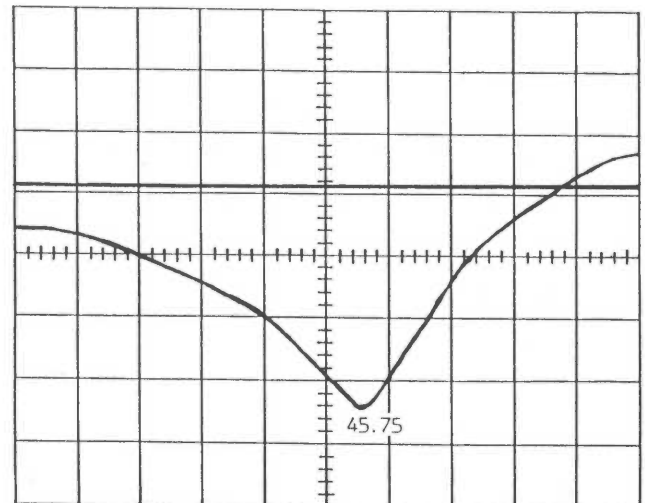

Single peak waveform

Fig. 61-a

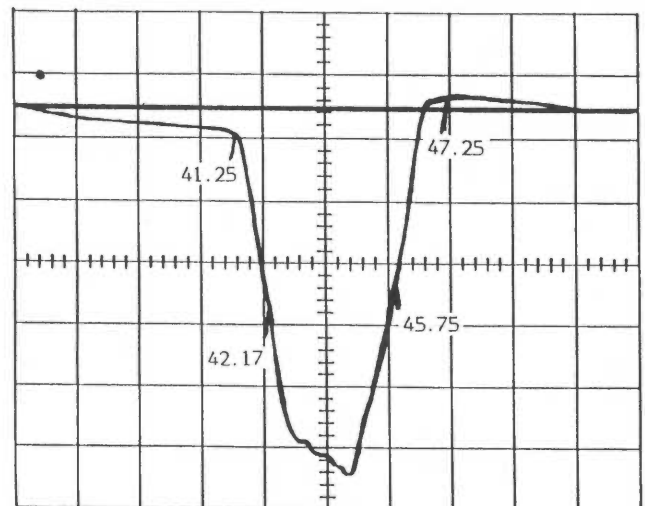

over all waveform

Fig. 61-b

### ■ E-62: AFT ADJUSTMENT

#### CONDITIONS

MODE - AFT SW ON

NOTE: Before adjustment, connect the 2.2K ohm resistor between Tuner Pack IP and AFT adjustment oscillator (45.75MHz). Remove the condenser of C6002 (50V, 0.01  $\mu\text{F}$ ), then adjust AFT. After the adjustment, re-connect C6002 (50V, 0.01  $\mu\text{F}$ ).

#### INSTRUCTIONS

- (1) Connect the output of AFT adjustment oscillator to Tuner Pack IP.
- (2) Connect TP6008 to the Voltmeter and adjust L6011 so that the voltage in the AFT switch ON mode is equal to the AFT switch OFF mode.

### ■ E-63: NOT REQUIRED FOR THIS MODEL

## ■ E-64: RF AGC ADJUSTMENT

### CONDITIONS

AFT SW - ON

### INSTRUCTIONS

- (1) Receive the signal of Monochrome Pattern.
- (2) Connect the DC Voltmeter to TP6009.
- (3) Set the RF input to 80dB.
- (4) Adjust VR6001 so that the voltage is equal to  $5.5 \pm 0.5V$ .

## ■ E-65: COLOR LEVEL ADJUSTMENT

### CONDITIONS

AFT SW - ON

### INSTRUCTIONS

- (1) Receive the signal of color bar.
- (2) Connect the oscilloscope to TP4202.
- (3) Adjust VR6002 so that the magenta level is  $400 \pm 50mV$  when Y-level is 1Vp-p.

## ■ E-66: CLOCK ADJUSTMENT

### CONDITIONS

MODE - STOP  
POWER ON  
CLOCK SET

NOTE: Quartz timer should be supplied with the power more than 30 minutes before the adjustment.

### INSTRUCTIONS

- (1) Connect the Quartz timer to TP601 and TP602 (GND).
- (2) Adjust TC601 so that day difference is within 0.15 sec.

### HOW TO RESET MICROCOMPUTER

When either or both of the following conditions occur, follow the procedure below.

#### CONDITIONS

- \* The digitron display does not light up.
- \* The unit does not stop, even when the "STOP" button is pressed.

#### PROCEDURE

- (1) Unplug the AC cord from AC outlet.
- (2) Insert a metal screwdriver into the hole at the bottom of the unit and short circuit for at least 10 seconds by contacting the screwdriver blade between the soldered face on the PCB and the metal portion of the bottom plate.

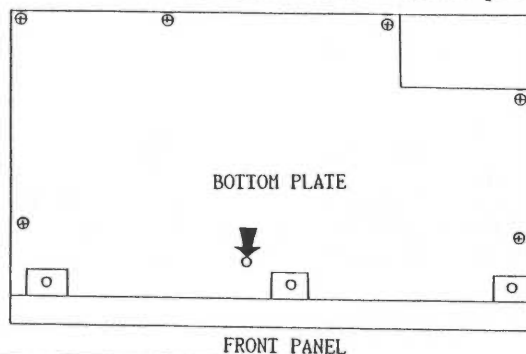

## DISASSEMBLY INSTRUCTIONS

### 1. REMOVAL OF TOP CABINET (See Fig. 1)

- A) Remove 2 screws (A) which are used for fixing the top cabinet.
- B) Lift the top cabinet in the direction shown by the arrow while expanding both sides a little, then slide it backward.

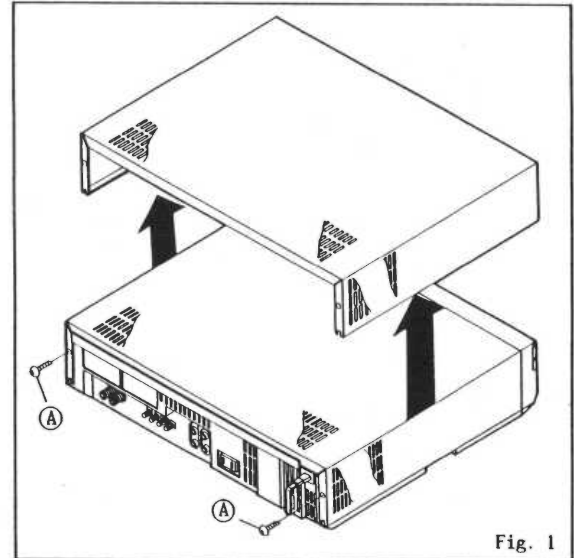

Fig. 1

### 2. REMOVAL OF BOTTOM PLATE (See Fig. 2)

- A) Remove 6 screws (A) which are used for fixing the bottom plate.
- B) Remove the bottom plate.

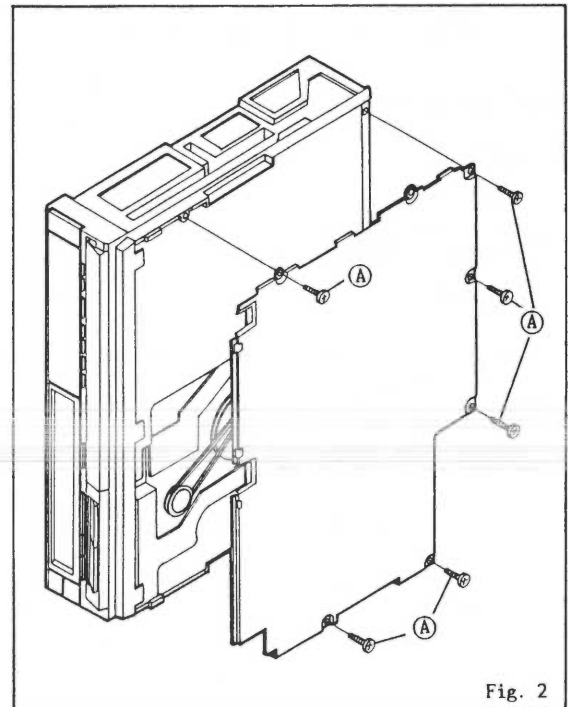

Fig. 2

3. REMOVAL OF FRONT CABINET (See Fig. 3)

- A) Unlock 6 PCB supports (A), then remove the front cabinet in the direction shown by the arrow.

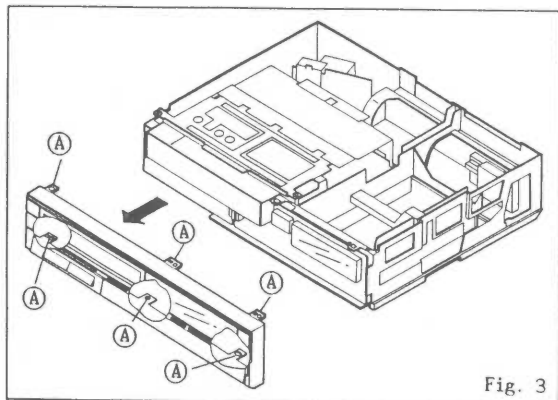

Fig. 3

4. CAUTION: BEFORE ATTEMPTING TO REMOVE FOR REPAIR ANY P.C.B. UNPLUG THE POWER CORD FROM THE A.C SOURCE.  
Location of Printed Circuit Boards (See Fig. 4)

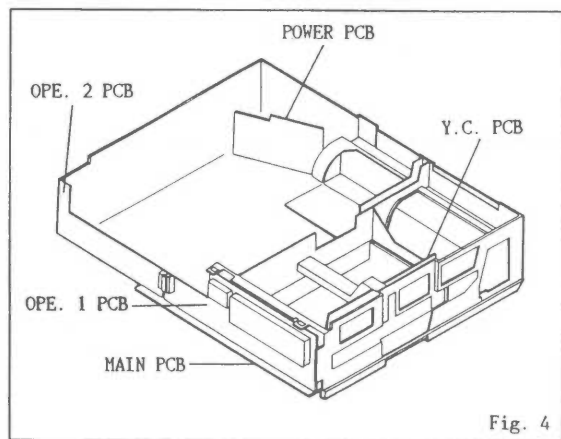

Fig. 4

5. REMOVAL OF PCB OPERATION 1, 2, MAIN (See Fig. 5)

- A) Remove 2 screws (A) which are used for fixing the Jack Plate.  
B) Remove 5 PCB supports (B) which are used for fixing the OPERATION 1 and 2. Then, remove 4 PCB supports (C) which are used for fixing the MAIN PCB.  
C) Move the PCB in the direction shown by the arrow.

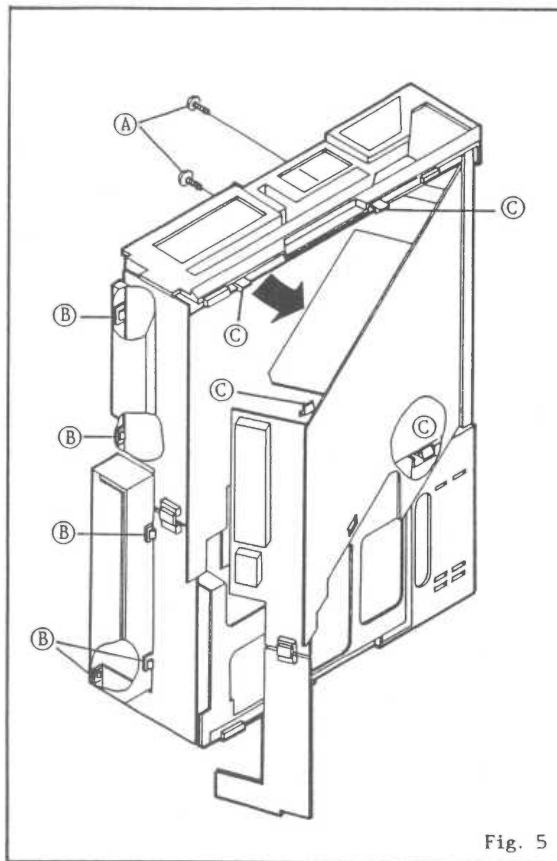

Fig. 5

6. REMOVAL OF PCB POWER (See Fig. 6)

- A) Remove 2 screws with (A) and remove PCB POWER/Heat Sink.  
B) Remove 2 screws (B) to remove PCB POWER from Heat Sink.

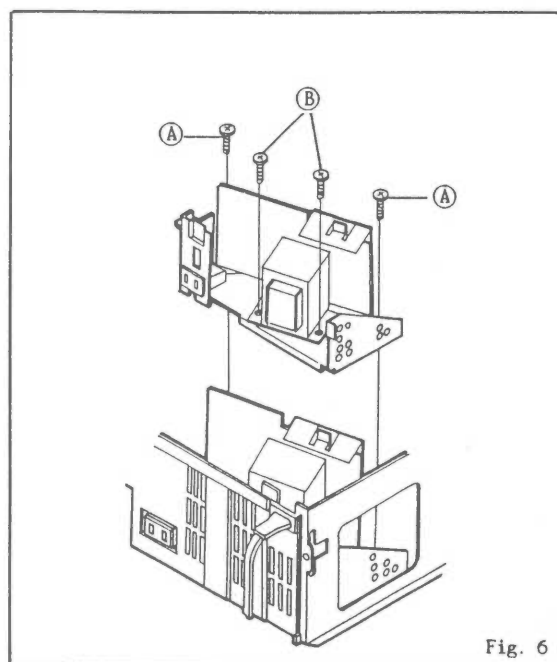
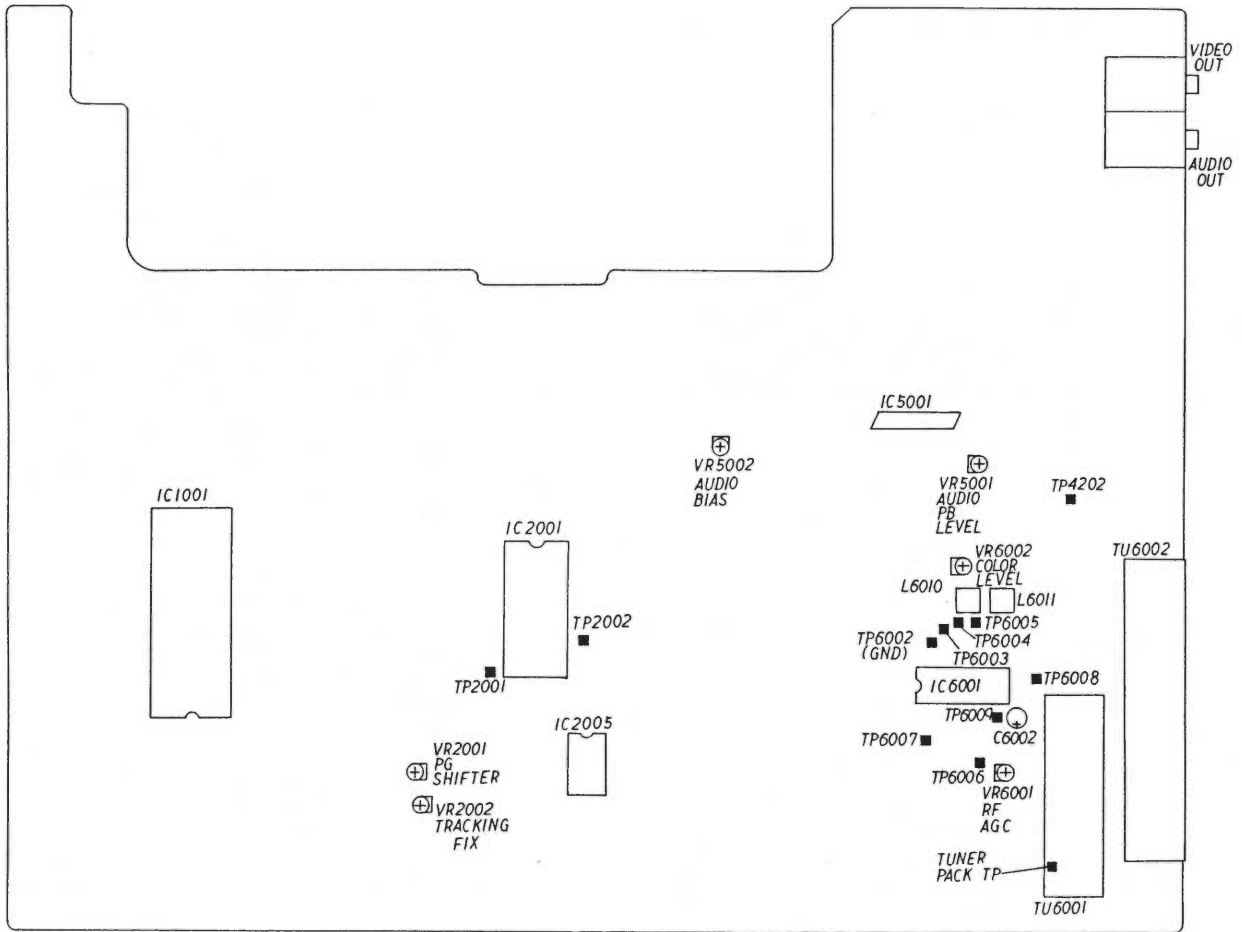
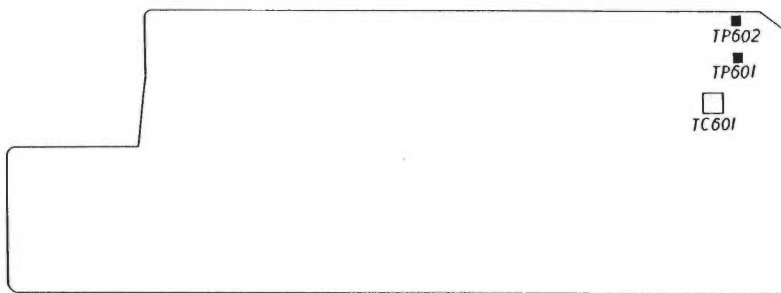

Fig. 6

# MAJOR COMPONENTS LOCATION GUIDE



MAIN P.C. BOARD



OPERATION 1 P.C. BOARD

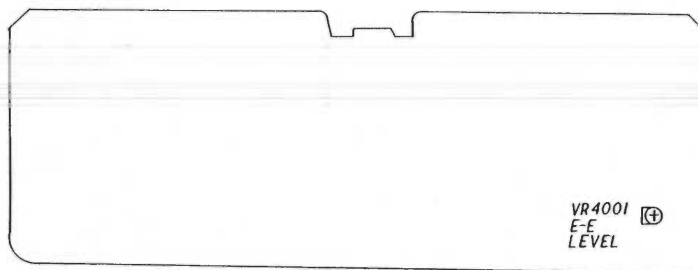

Y/C P.C. BOARD

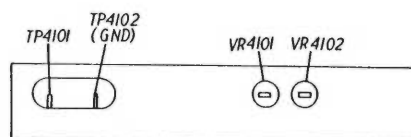

HEAD AMP



Y/C / HEAD AMP BLOCK DIAGRAM

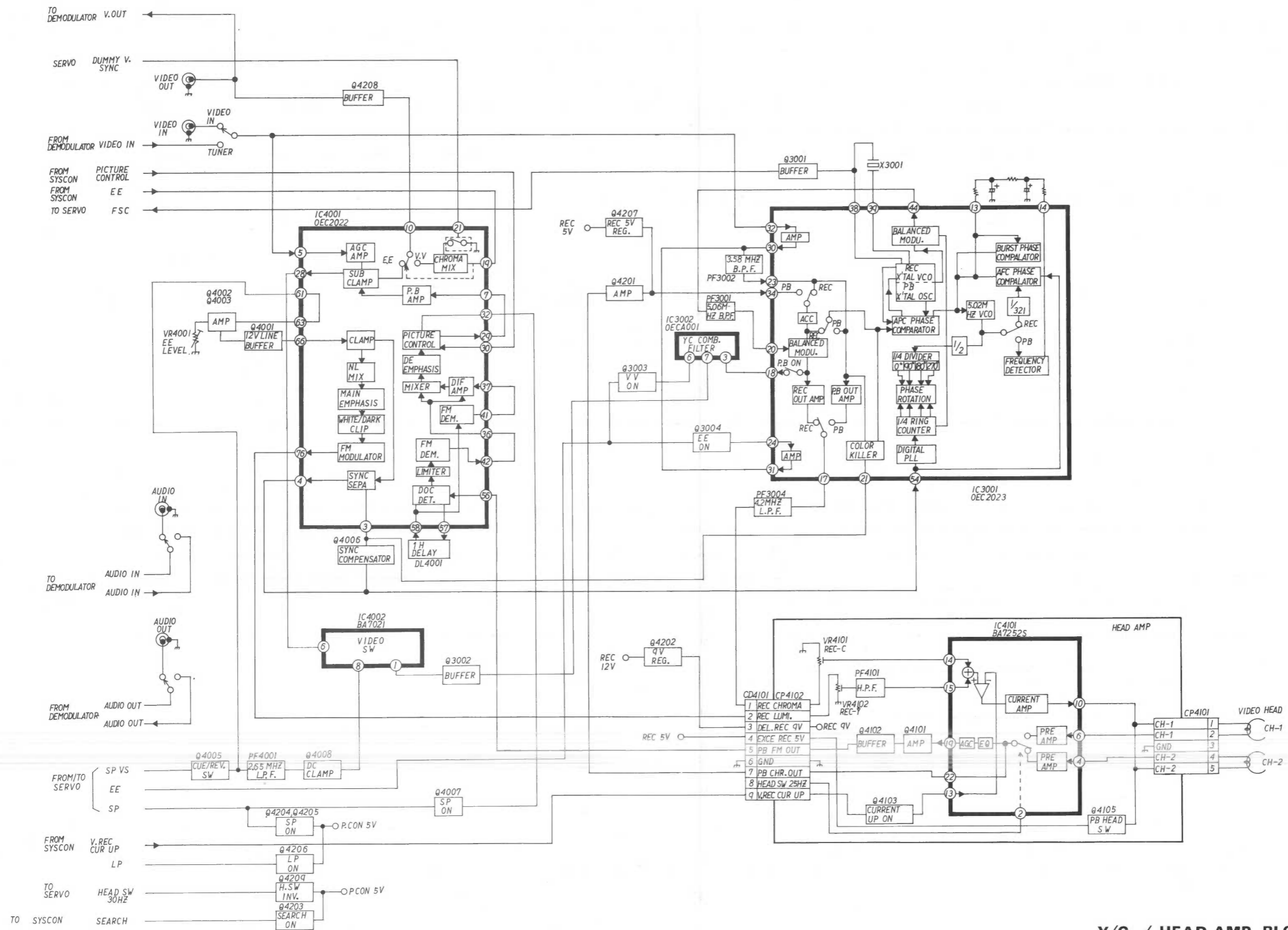

Y/C / HEAD AMP BLOCK DIAGRAM

OPERATION 1 / 2 BLOCK DIAGRAM

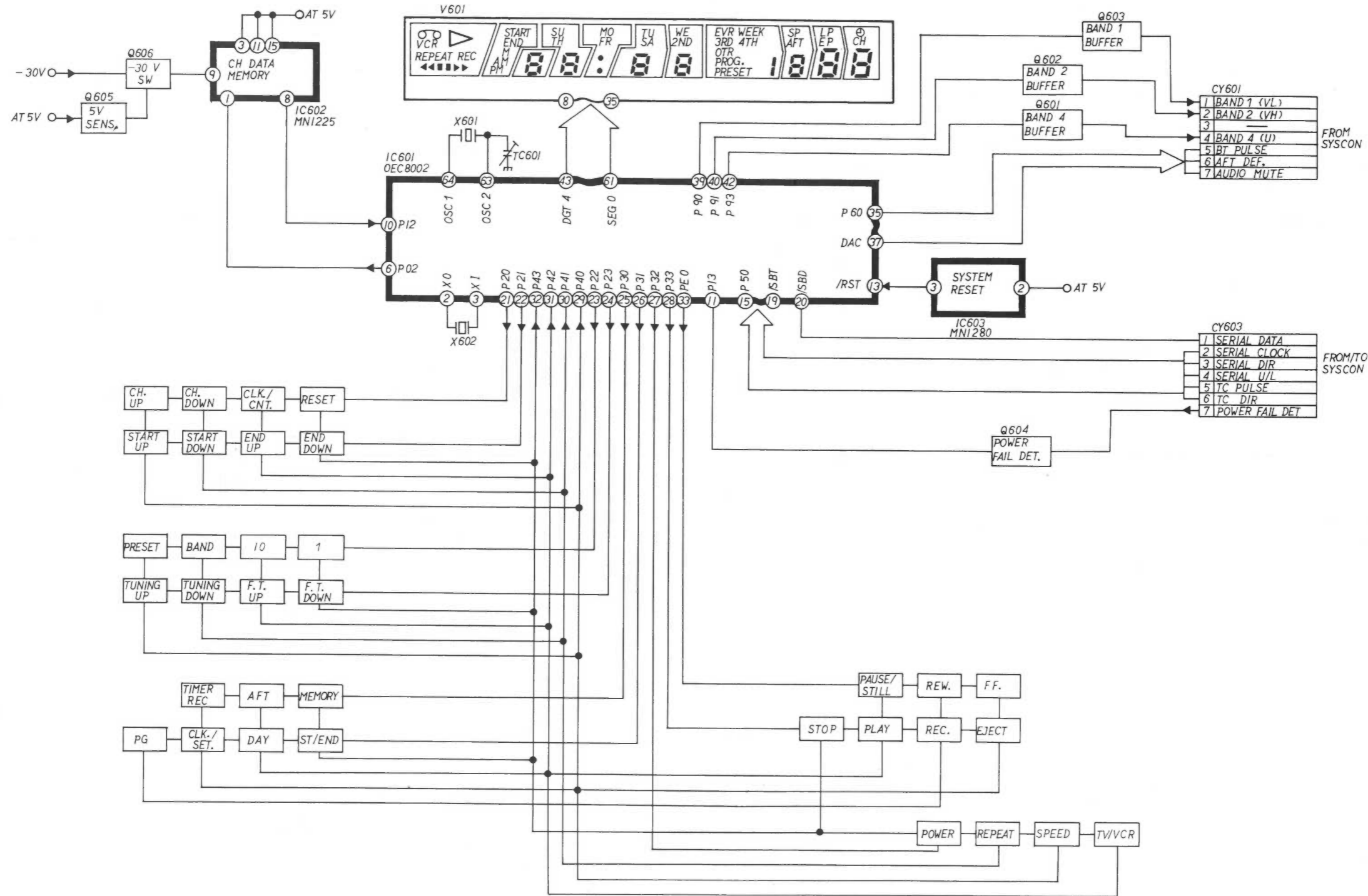

OPERATION 1 / 2 BLOCK DIAGRAM

### SYSTEM CONTROL BLOCK DIAGRAM

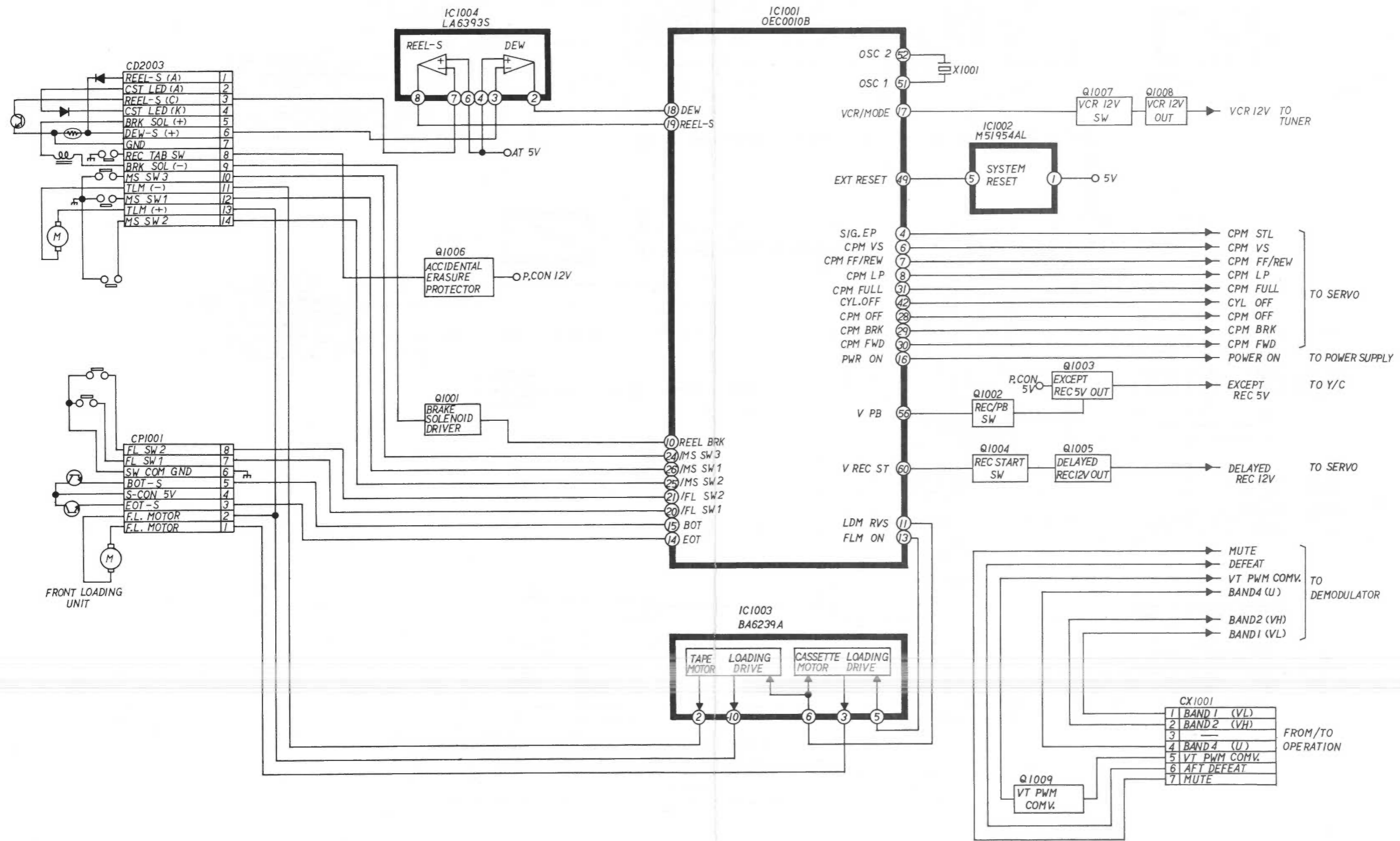

**SYSTEM CONTROL BLOCK DIAGRAM**

# SERVO BLOCK DIAGRAM

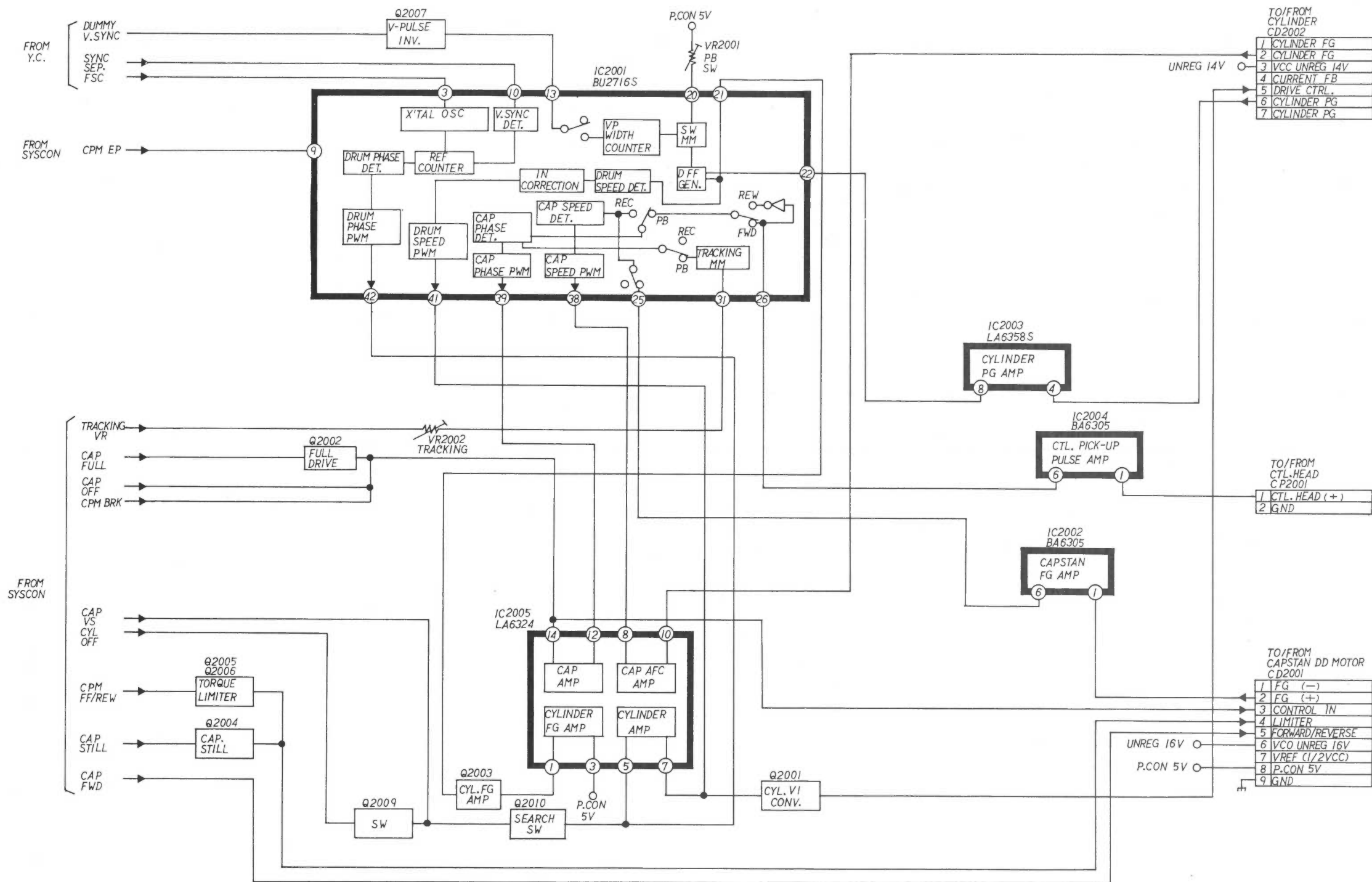

SERVO BLOCK DIAGRAM

**DEMODULATOR BLOCK DIAGRAM**

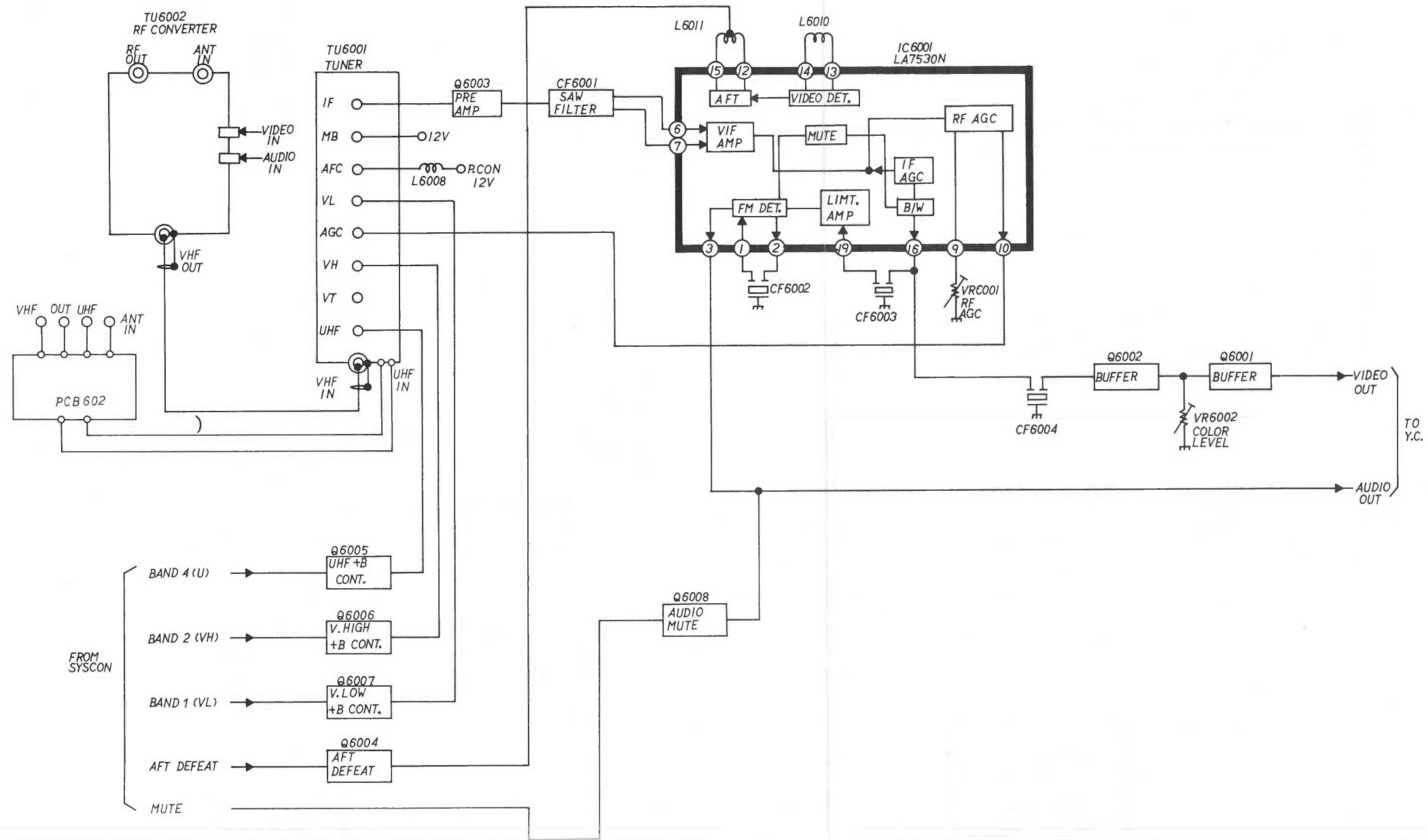

**DEMODULATOR BLOCK DIAGRAM**

### AUDIO BLOCK DIAGRAM

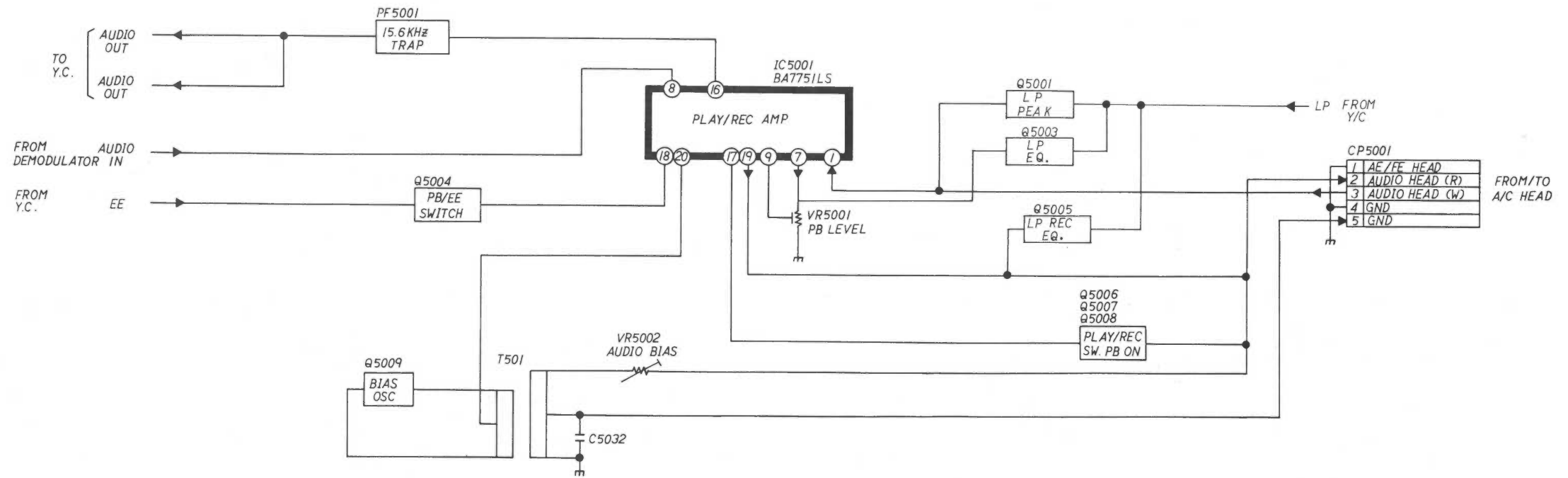

### POWER SUPPLY BLOCK DIAGRAM

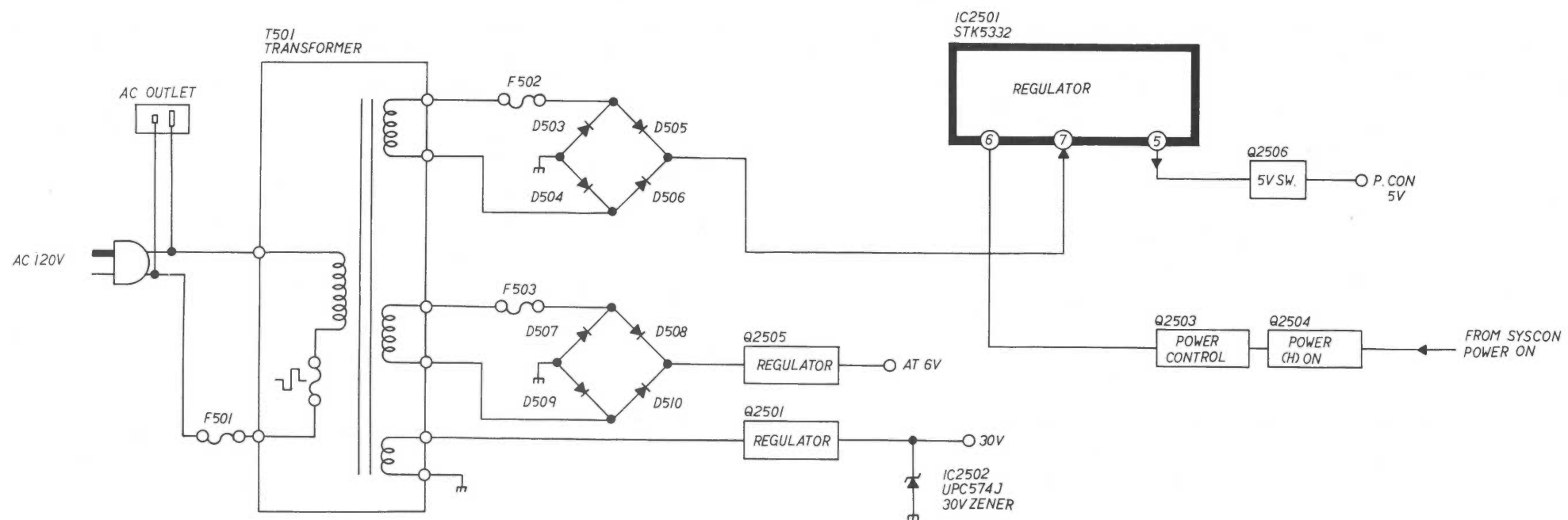

MAIN/ Y/C P.C. BOARD

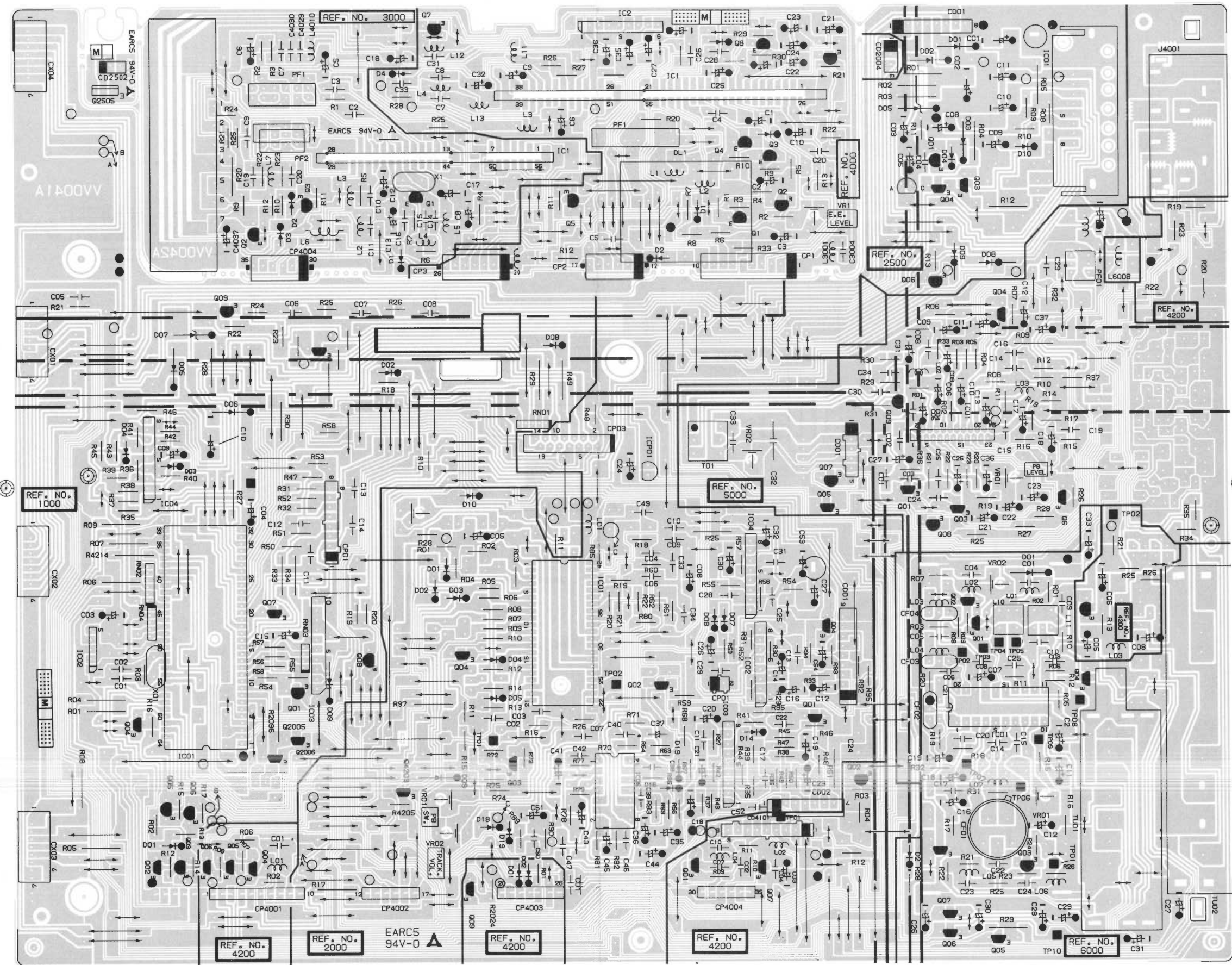

MAIN/ Y/C P.C. BOARD



OPERATION 1 / 2 SCHEMATIC DIAGRAM

VOLTAGE IS PLAY/BACK.

CAUTION: DIGITAL TRANSISTOR

CAUTION: DIGITAL TRANSISTOR

NOTE: THIS SCHEMATIC DIAGRAM IS THE LATEST AT THE TIME OF PRINTING AND SUBJECT TO CHANGE WITHOUT NOTICE.

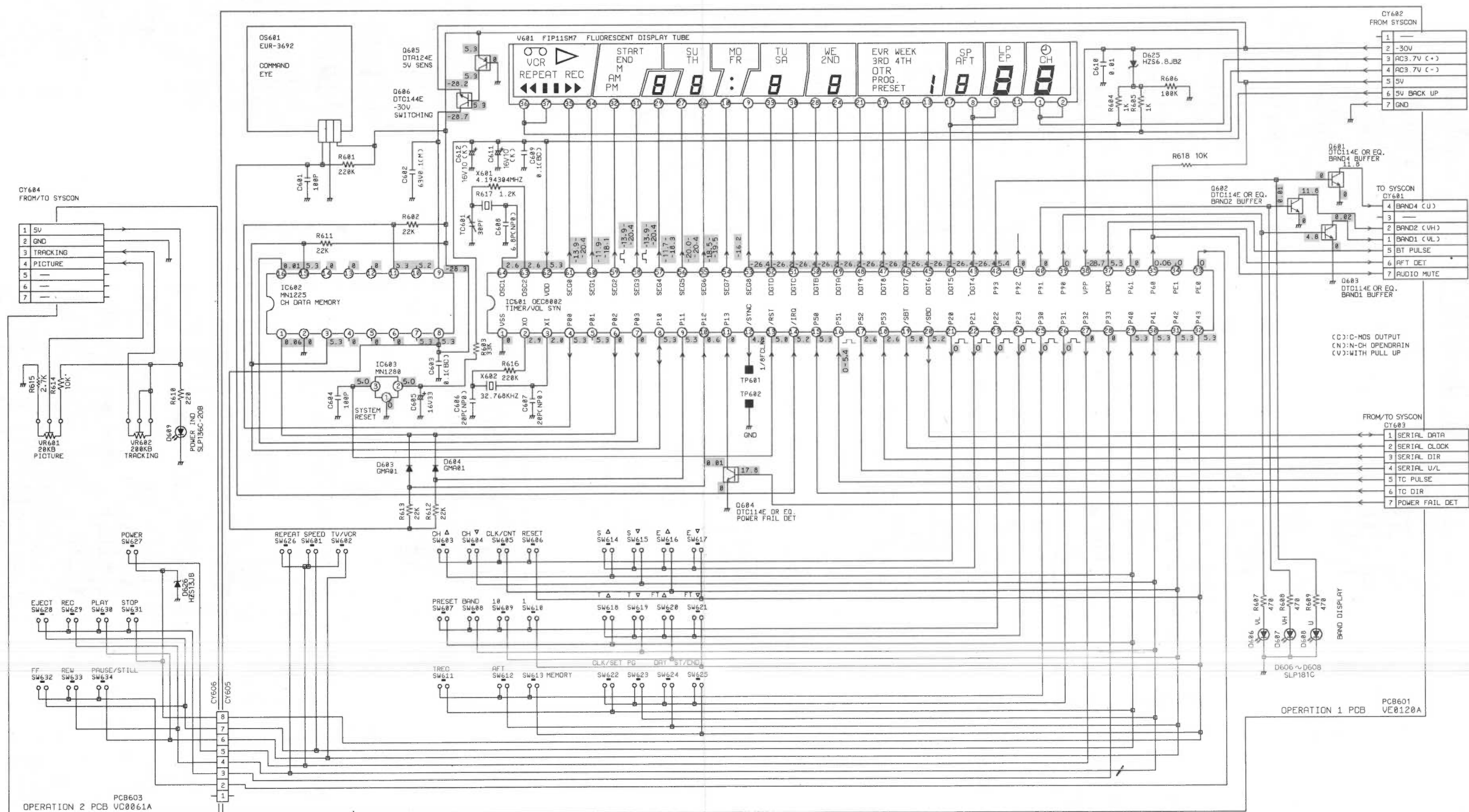

CY604 FROM/TO SYSCON

1	5V
2	GND
3	TRACKING
4	PICTURE
5	
6	
7	

CY602 FROM SYSCON

1	
2	-30V
3	AC3.7V (C+)
4	AC3.7V (C-)
5	5V
6	5V BACK UP
7	GND

TO SYSCON CY601

4	BAND4 (CJ)
3	
2	BAND2 (VH)
1	BAND1 (VL)
5	BT PULSE
6	AFT DET
7	AUDIO MUTE

FROM/TO SYSCON CY603

1	SERIAL DATA
2	SERIAL CLOCK
3	SERIAL DIR
4	SERIAL U/L
5	TC PULSE
6	TC DIR
7	POWER FAIL DET

PCB603  
 OPERATION 2 PCB VC0061A

PCB601  
 VE0120A  
 OPERATION 1 PCB

OPERATION 1 / 2 SCHEMATIC DIAGRAM

# AUDIO SCHEMATIC DIAGRAM

CAUTION: DIGITAL TRANSISTOR



NOTE: THIS SCHEMATIC DIAGRAM IS THE LATEST AT THE TIME OF PRINTING AND SUBJECT TO CHANGE WITHOUT NOTICE.

VOLTAGE IS PLAY/BACK.

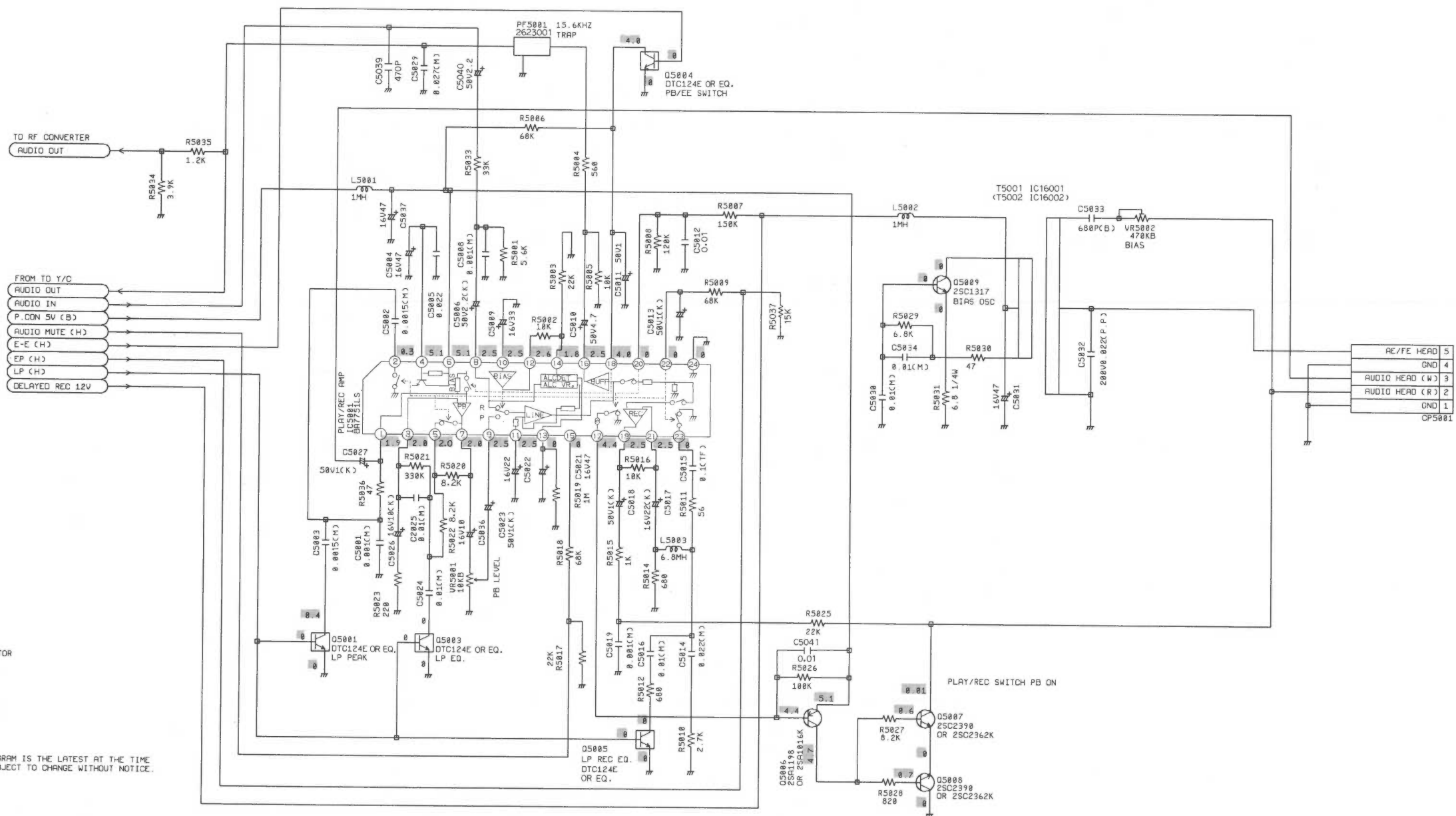

# AUDIO SCHEMATIC DIAGRAM

# SYSTEM CONTROL SCHEMATIC DIAGRAM

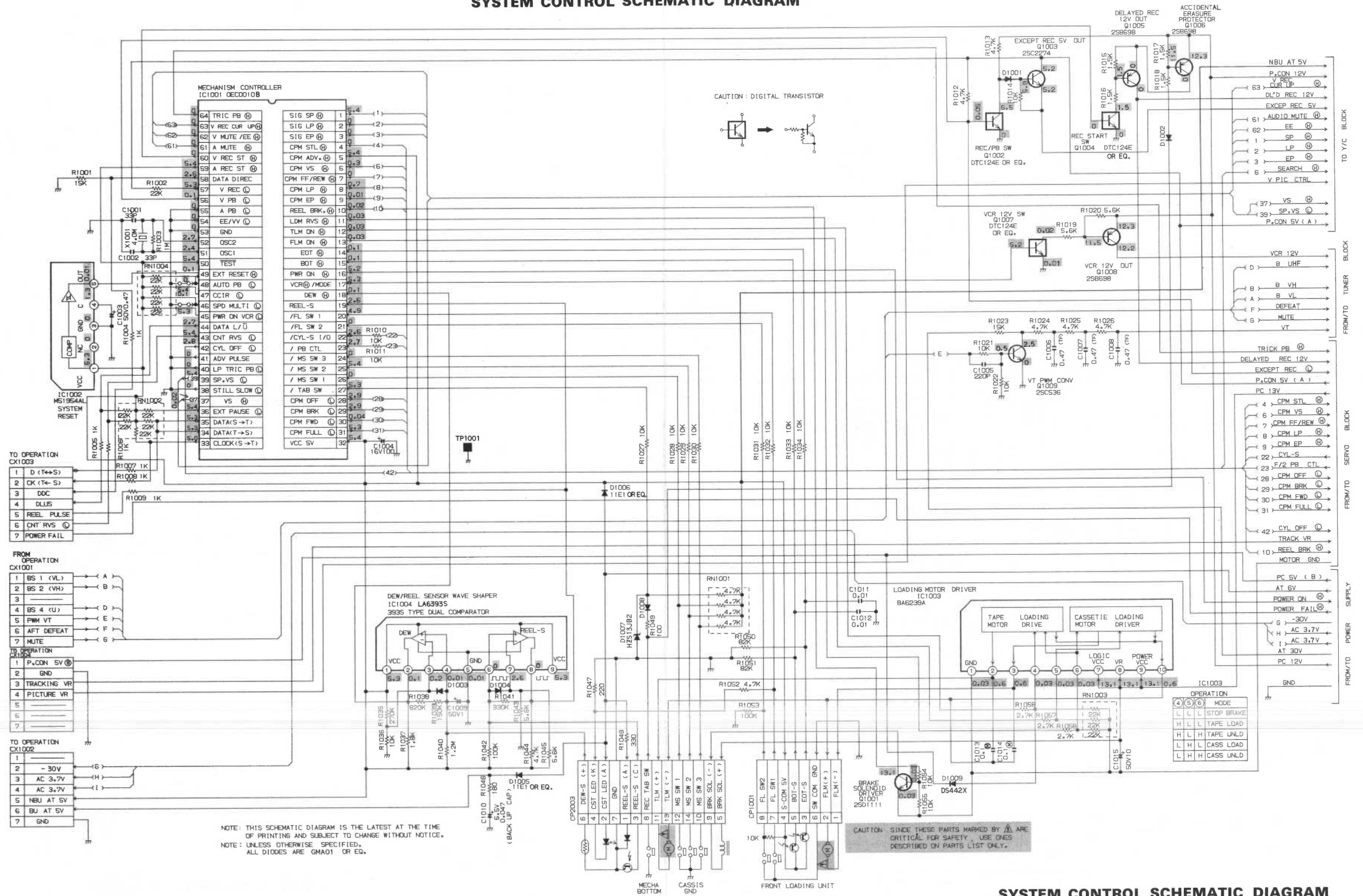

SYSTEM CONTROL SCHEMATIC DIAGRAM



# DEMODULATOR SCHEMATIC DIAGRAM

www.servicemanuals.net  
10 North Main St.  
Wharton, NJ 07885

VOLTAGE IS PLAY/BACK.

CAUTION: SINCE THESE PARTS MARKED BY  ARE CRITICAL FOR SAFETY, USE ONES DESCRIBED ON PARTS LIST ONLY.

NOTE: THIS SCHEMATIC DIAGRAM IS THE LATEST AT THE TIME OF PRINTING AND SUBJECT TO CHANGE WITHOUT NOTICE.

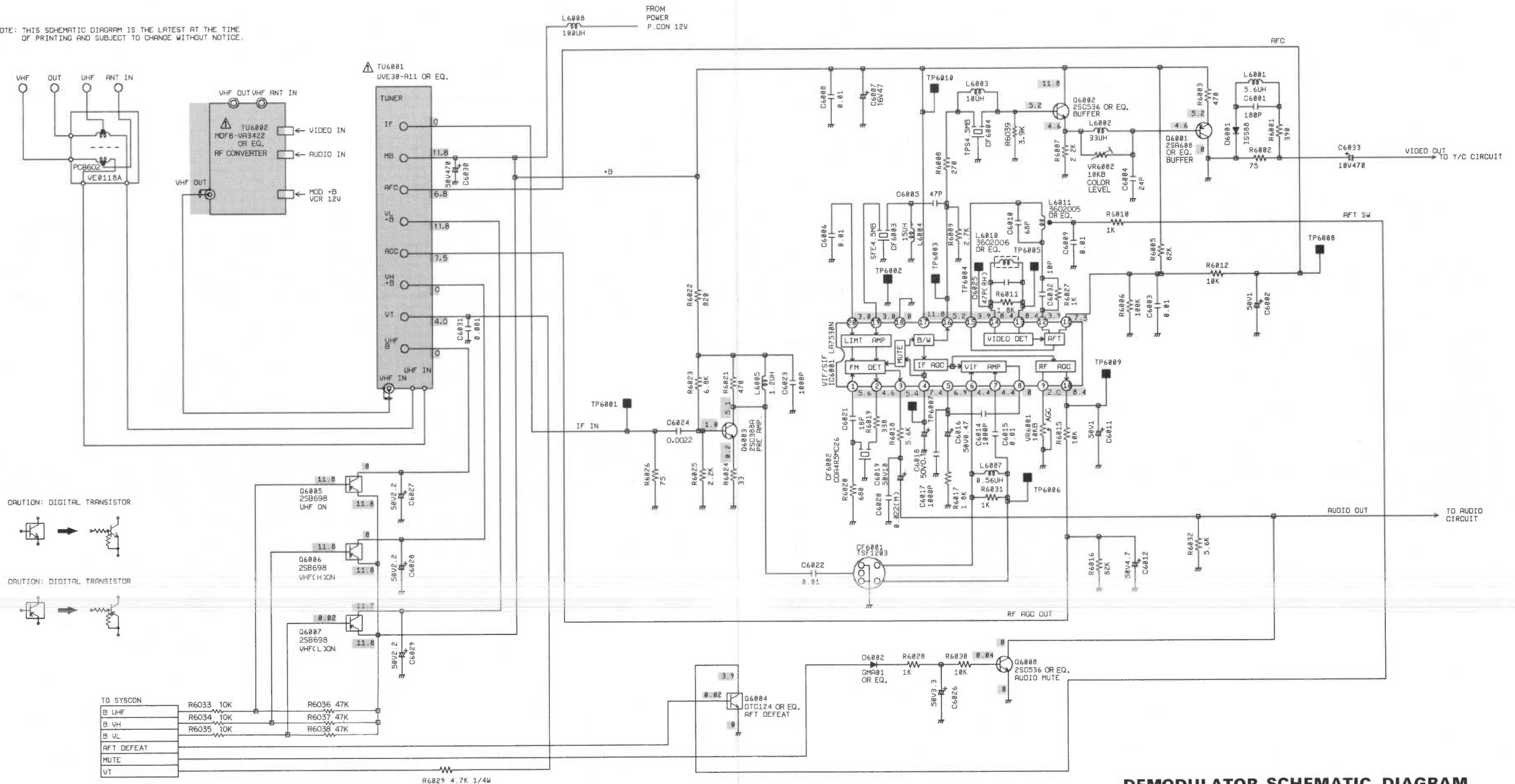

CAUTION: DIGITAL TRANSISTOR



CAUTION: DIGITAL TRANSISTOR

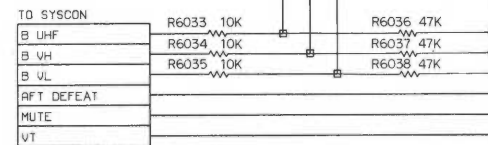

R6029 4.7K 1/4W

# DEMODULATOR SCHEMATIC DIAGRAM

### Y/C SCHEMATIC DIAGRAM

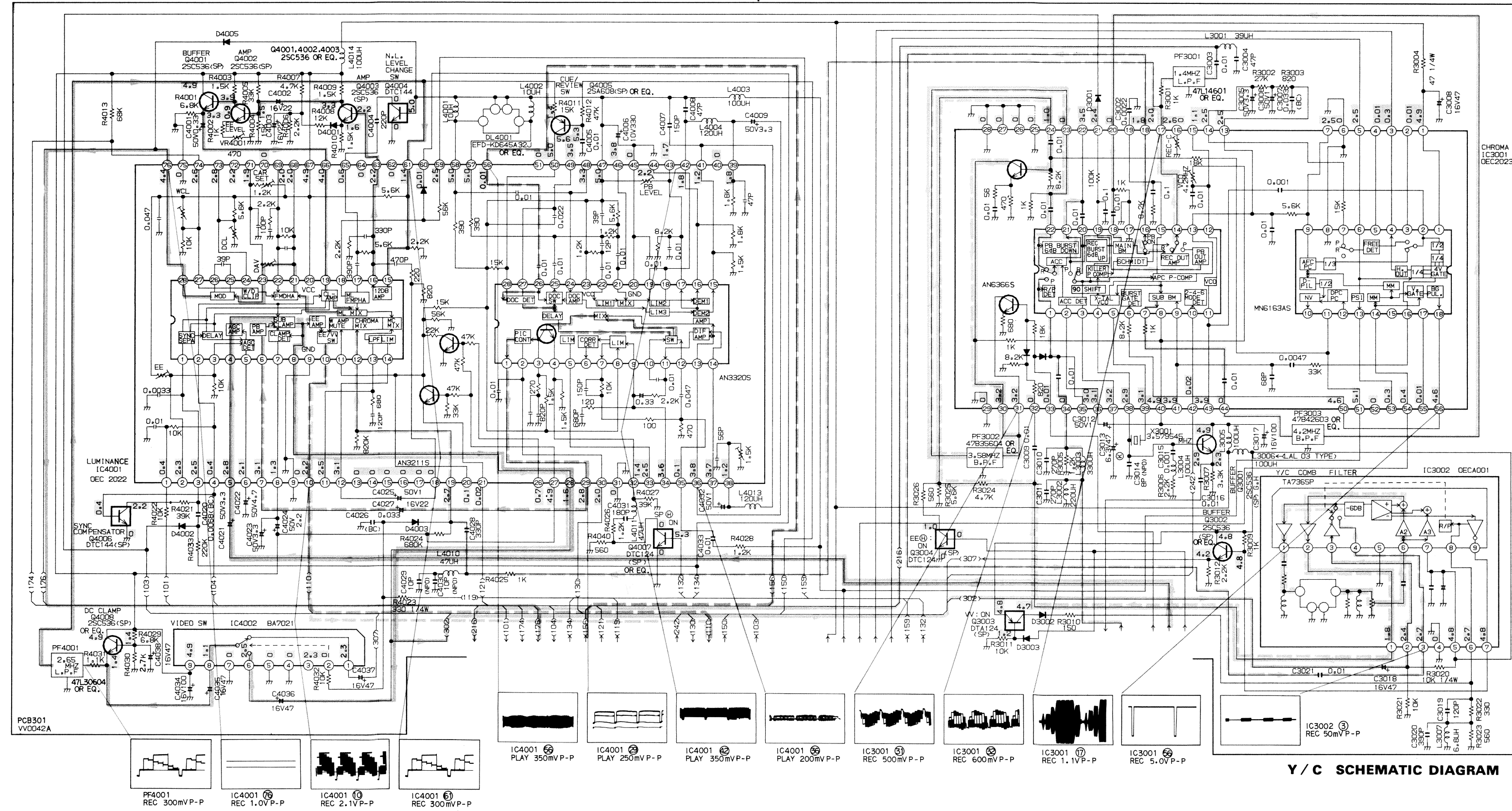

Y/C / HEAD AMP SCHEMATIC DIAGRAM

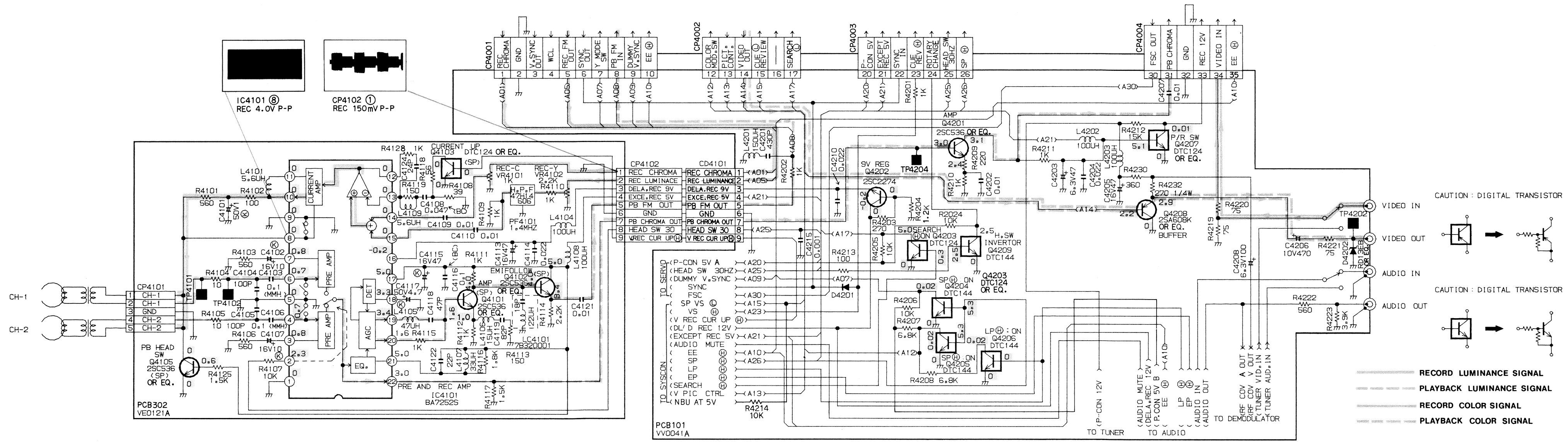

NOTE: THIS SCHEMATIC DIAGRAM IS THE LATEST AT THE TIME OF PRINTING AND SUBJECT TO CHANGE WITHOUT NOTICE.

NOTE: UNLESS OTHERWISE SPECIFIED, ALL DIODES ARE GMA01 OR EQ.

# POWER SUPPLY SCHEMATIC DIAGRAM

CAUTION: SINCE THESE PARTS MARKED BY  $\Delta$  ARE CRITICAL FOR SAFETY, USE ONES DESCRIBED ON PARTS LIST ONLY.

VOLTAGE IS PLAY/BACK.

CAUTION: DIGITAL TRANSISTOR



NOTE: THIS SCHEMATIC DIAGRAM IS THE LATEST AT THE TIME OF PRINTING AND SUBJECT TO CHANGE WITHOUT NOTICE.

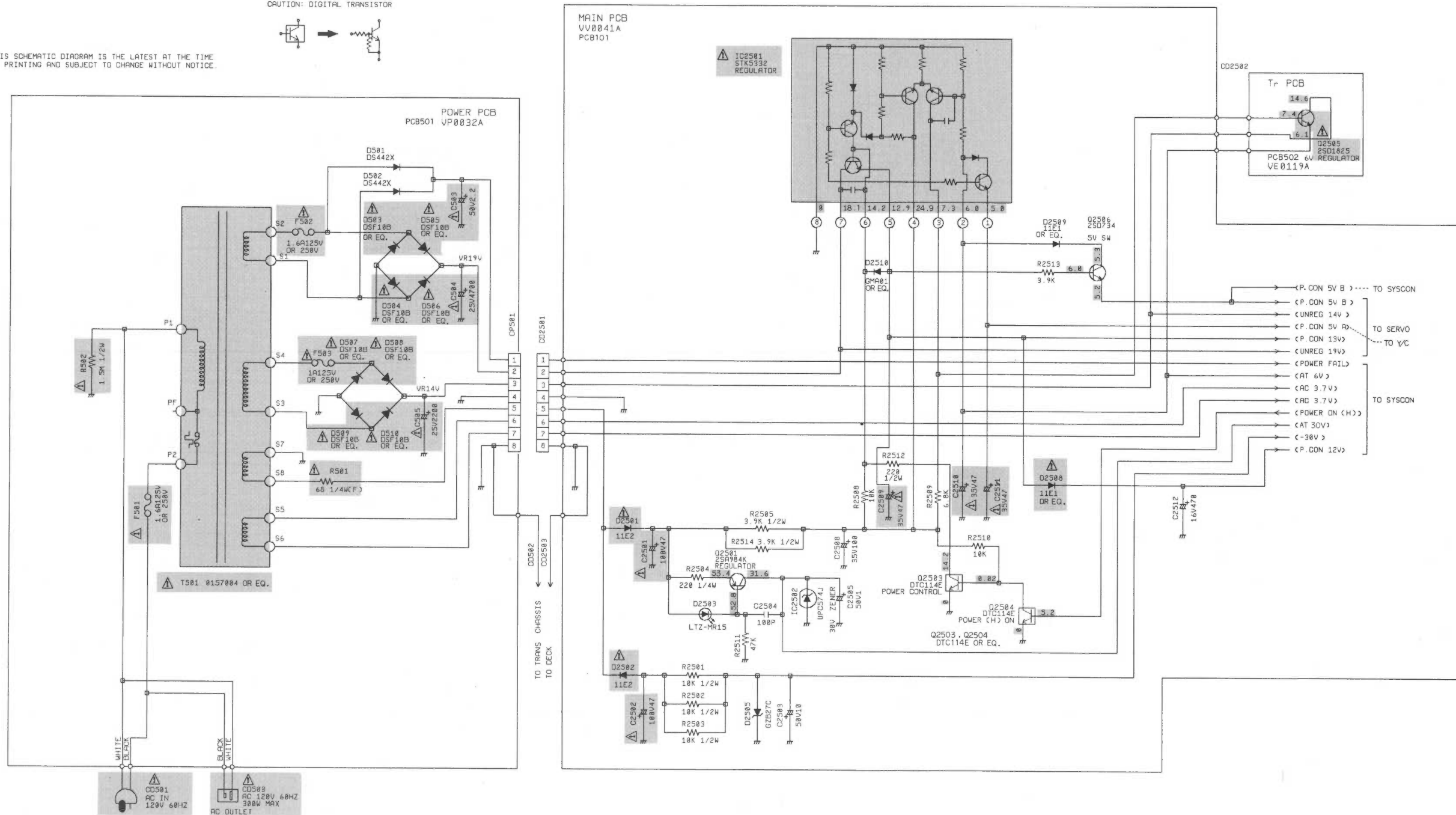

POWER SUPPLY SCHEMATIC DIAGRAM

### INTERCONNECTION

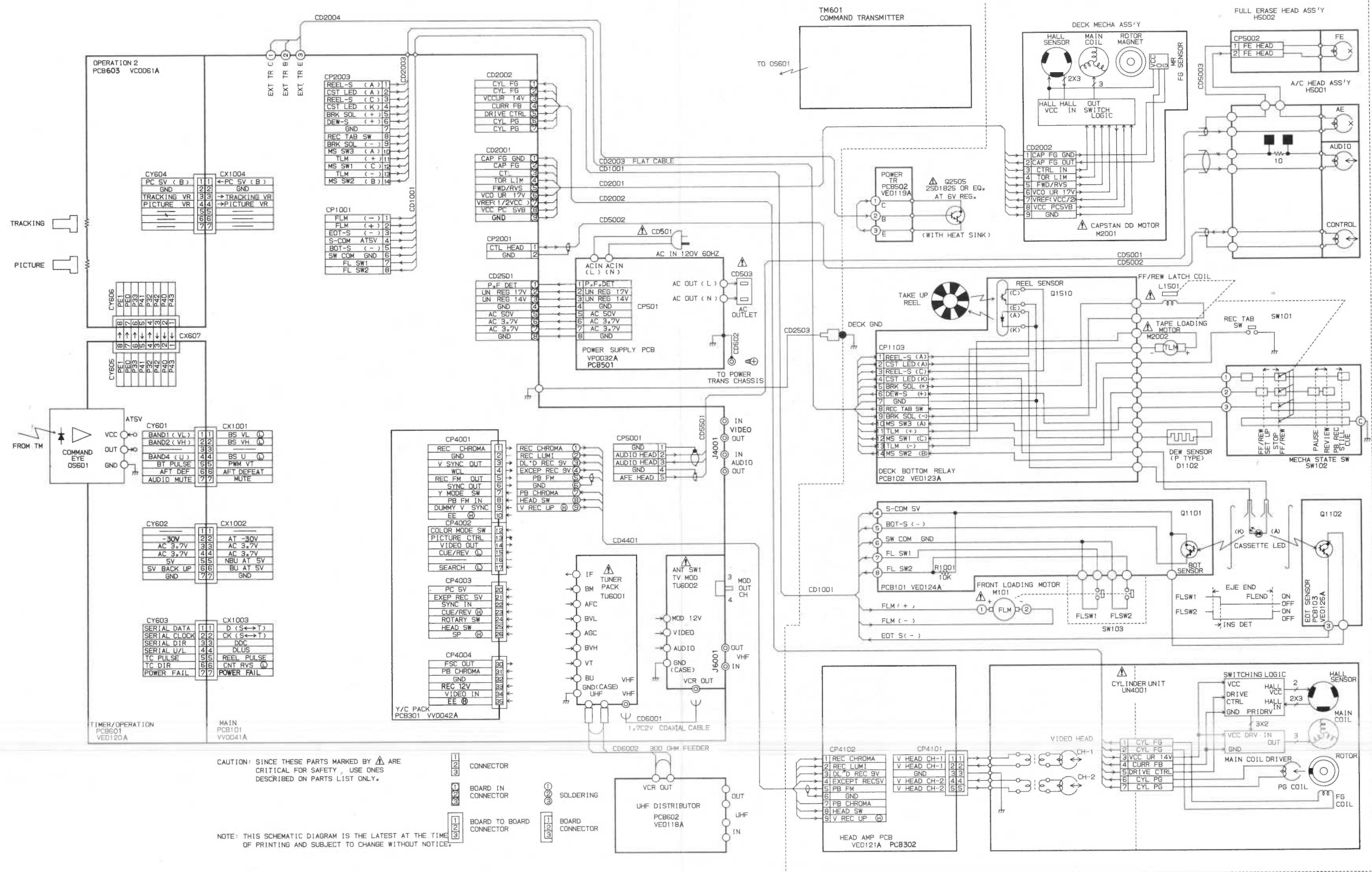

# MECHANICAL EXPLODED VIEW

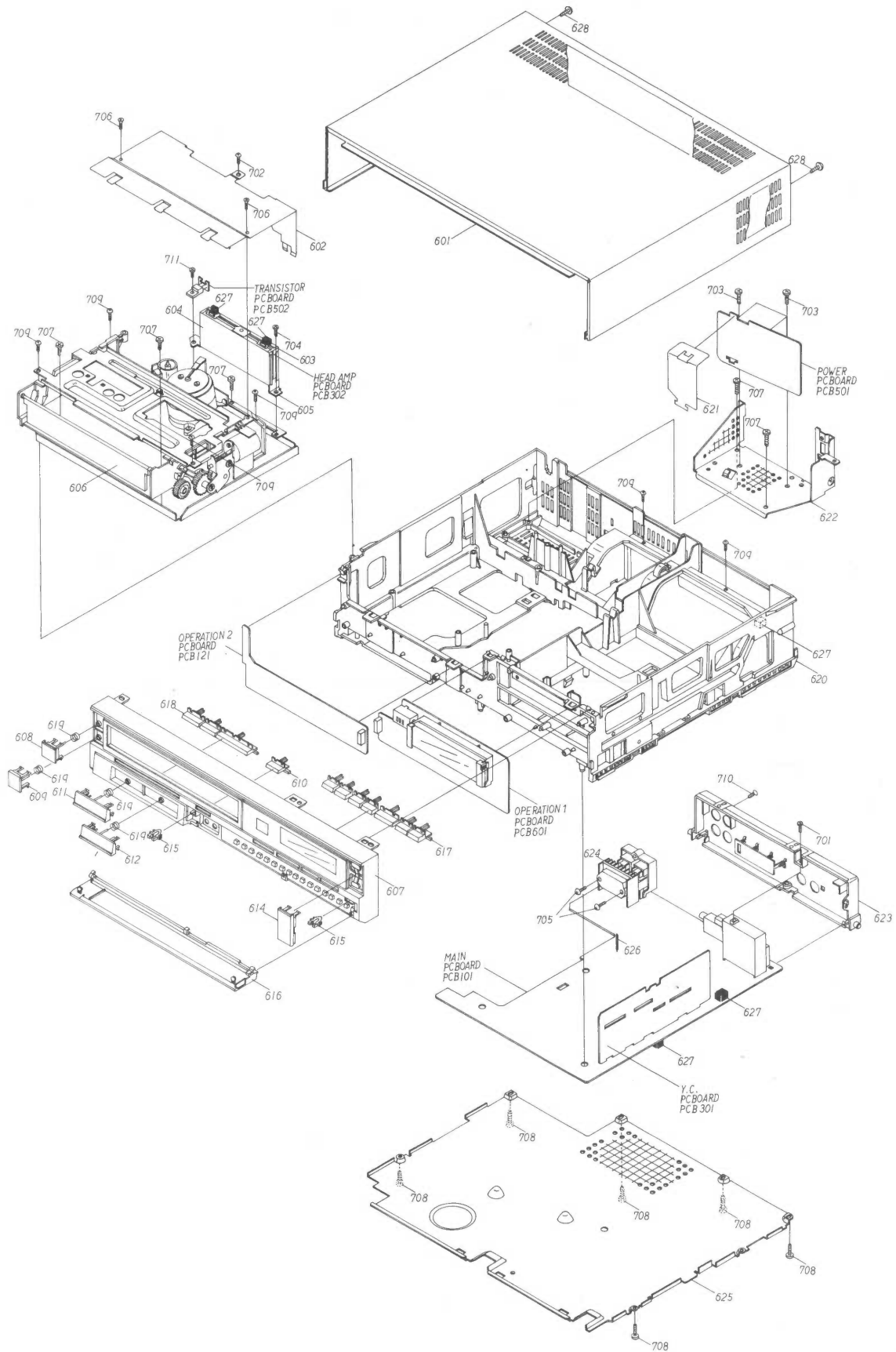



# DECK EXPLODED VIEW

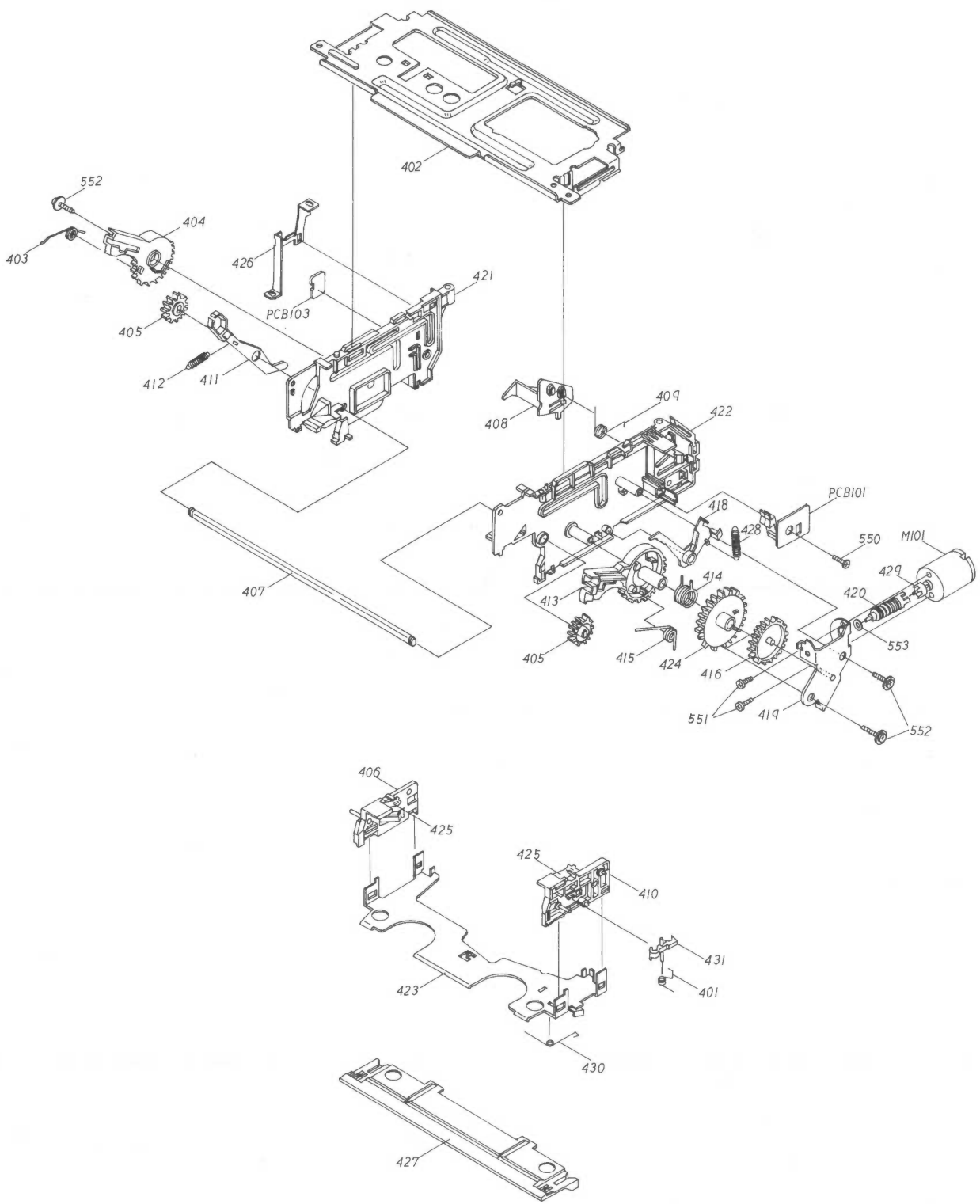

THIS ELECTRICAL PARTS LIST IS STANDARD PARTS LIST, BUT ACTUALLY INTERCHANGEABLE PARTS MAY BE USED IN THE UNIT. SEE THE INTERCHANGEABLE PARTS LIST AFTER THE STANDARD PARTS LIST.

ELECTRICAL REPLACEMENT PARTS LIST

REF. NO	PARTS. NO	DESCRIPTION	REF. NO	PARTS. NO	DESCRIPTION
-RESISTORS-			-SEMICONDUCTORS (CONT)-		
△ R501	R61584680J	R. FUSE 68 OHM 1/4W	D2510	D13TGMA010	DIODE, SILICON GMA-01-BT
△ R502	R011K2155J	RC 1.5M OHM 1/2W	D3001	D13TGMA010	DIODE, SILICON GMA-01-BT
R3004	R01124470J	RC 47 OHM 1/4W	D3002	D13TGMA010	DIODE, SILICON GMA-01-BT
R4125	R01106152J	RC 1.5K OHM 1/6W	D3003	D13TGMA010	DIODE, SILICON GMA-01-BT
R6026	R01124750J	RC 75 OHM 1/4W	D4001	D13TGMA010	DIODE, SILICON GMA-01-BT
-CAPACITORS-			-SEMICONDUCTORS (CONT)-		
△ C503	E011F52R2M	CE 2.2 UF 50 V	D4002	D13TGMA010	DIODE, SILICON GMA-01-BT
△ C504	E027F3472M	CE 4700 UF 25 V	D4003	D13TGMA010	DIODE, SILICON GMA-01-BT
△ C505	E011F3222M	CE 2200 UF 25 V	D4005	D13TGMA010	DIODE, SILICON GMA-01-BT
C603	C630B0215Z	CC 0.1 UF 16 V	D4201	D13TGMA010	DIODE, SILICON GMA-01-BT
C609	C630B0215Z	CC 0.1 UF 16 V	D4202	D92T0130B0	DIODE, ZENER RD13EB-TA11R
C611	E01302100M	CE 10 UF 16 V	D6001	D140000880	DIODE, SILICON 1SS88
C612	E01302100M	CE 10 UF 16 V	D6002	D13TGMA010	DIODE, SILICON GMA-01-BT
C1006	P613F0474J	CMPL 0.47 UF 50 V	IC601	I51DT80020	INTEGRATED CIRCUIT OEC8002
C1007	P613F0474J	CMPL 0.47 UF 50 V	IC602	I31D012250	INTEGRATED CIRCUIT MN1225
C1008	P613F0474J	CMPL 0.47 UF 50 V	IC603	I01901280M	INTEGRATED CIRCUIT MN1280
C1010	E05X0P479Z	CE 0.047 UF 5.5V	IC1001	I54D50010B	INTEGRATED CIRCUIT OEC0010B
△ C2501	E011F8470M	CE 47 UF 100V	IC1002	I06S51954A	INTEGRATED CIRCUIT M51954AL
△ C2502	E011F8470M	CE 47 UF 100V	IC1003	I07S06239A	INTEGRATED CIRCUIT BA6239A
C2512	E01102471M	CE 470 UF 16 V	IC1004	I03S063930	INTEGRATED CIRCUIT LA6393S
C4022	E011054R7M	CE 4.7 UF 50 V	IC2001	I97D490020	INTEGRATED CIRCUIT OEC9002
C4035	E01102470M	CE 47 UF 16 V	IC2002	I07S463050	INTEGRATED CIRCUIT BA6305
C4108	C630B0304Z	CC 0.047 UF 25 V	IC2003	I03S063580	INTEGRATED CIRCUIT LA6358S
C4116	C630B0215Z	CC 0.1 UF 16 V	IC2004	I07S463050	INTEGRATED CIRCUIT BA6305
C5011	E01105010M	CE 1 UF 50 V	IC2005	I03D063240	INTEGRATED CIRCUIT LA6324
C5032	P341F2223J	CPP 0.022 UF 200V	IC2501	I23S953320	INTEGRATED CIRCUIT STK5332
C6030	E01102471M	CE 470 UF 16 V	IC2502	I02990574J	INTEGRATED CIRCUIT UPC574J
-SEMICONDUCTORS-			IC3001	I2MD320230	HYBRID PCB OEC2023
D501	D13TDS442X	DIODE, SILICON DS442X-BT	IC3002	I2AU3A0010	INTEGRATED CIRCUIT OECA001
D502	D13TDS442X	DIODE, SILICON DS442X-BT	IC4001	I2MD320220	HYBRID PCB OEC2022
△ D503	D23TDSF10B	DIODE, RECTIFIER DSF-10B-BT	IC4002	I07S070210	INTEGRATED CIRCUIT BA7021
△ D504	D23TDSF10B	DIODE, RECTIFIER DSF-10B-BT	IC4101	I07DG7252S	INTEGRATED CIRCUIT BA7252S
△ D505	D23TDSF10B	DIODE, RECTIFIER DSF-10B-BT	IC5001	I07T67751L	INTEGRATED CIRCUIT BA7751LS
△ D506	D23TDSF10B	DIODE, RECTIFIER DSF-10B-BT	IC6001	I03DA7530N	INTEGRATED CIRCUIT LA7530N
△ D507	D23TDSF10B	DIODE, RECTIFIER DSF-10B-BT	Q601	TN7TB03001	COMPOUND, TRANSISTOR DTC114E S-T
△ D508	D23TDSF10B	DIODE, RECTIFIER DSF-10B-BT	Q602	TN7TB03001	COMPOUND, TRANSISTOR DTC114E S-T
△ D509	D23TDSF10B	DIODE, RECTIFIER DSF-10B-BT	Q603	TN7TB03001	COMPOUND, TRANSISTOR DTC114E S-T
△ D510	D23TDSF10B	DIODE, RECTIFIER DSF-10B-BT	Q604	TN7TB03001	COMPOUND, TRANSISTOR DTA114E S-T
D603	D13TGMA010	DIODE, SILICON GMA-01-BT	Q605	TP7TC03001	COMPOUND, TRANSISTOR DTC124E S-T
D604	D13TGMA010	DIODE, SILICON GMA-01-BT	Q606	TN7D03001	COMPOUND, TRANSISTOR DTC144E S-T
D606	0021320110	LED SLP181C	Q1001	TD3T011110	TRANSISTOR, SILICON 2SD1111-T
D607	0021320110	LED SLP181C	Q1002	TN7TC03001	COMPOUND, TRANSISTOR DTC124E S-T
D608	0021320110	LED SLP181C	Q1003	TC3T022740	TRANSISTOR, SILICON 2SC2274
D609	0021320100	LED SLP136C-20B	Q1004	TN7TC03001	COMPOUND, TRANSISTOR DTC124E S-T
D625	D94TA6R8J2	DIODE, ZENER HZS6R8JB2-TE	Q1005	TB3T006980	TRANSISTOR, SILICON 2SB698-T
D626	D94TA130J2	DIODE, ZENER HZS13JB2-TE	Q1006	TB3T006980	TRANSISTOR, SILICON 2SB698-T
D1001	D13TGMA010	DIODE, SILICON GMA-01-BT	Q1007	TN7TC03001	COMPOUND, TRANSISTOR DTC124E S-T
D1002	D13TGMA010	DIODE, SILICON GMA-01-BT	Q1008	TB3T006980	TRANSISTOR, SILICON 2SB698-T
D1003	D13TGMA010	DIODE, SILICON GMA-01-BT	Q1009	TC3T0536K0	TRANSISTOR, SILICON 2SC536KNP-T
D1004	D13TGMA010	DIODE, SILICON GMA-01-BT	Q2001	TC3T0536S0	TRANSISTOR, SILICON 2SC536SP-AC
D1005	D28T011E10	DIODE, SILICON 11E1TA1-T	Q2002	TP7TC03001	COMPOUND, TRANSISTOR DTA124E S-T
D1006	D28T011E10	DIODE, SILICON 11E1TA1-T	Q2003	TC3T0536S0	TRANSISTOR, SILICON 2SC536SP-AC
D1007	D94TA130J2	DIODE, ZENER HZS13JB2-TE	Q2004	TN7TB03001	COMPOUND, TRANSISTOR DTC114E S-T
D1008	D13TGMA010	DIODE, SILICON GMA-01-BT	Q2005	TN7TC03001	COMPOUND, TRANSISTOR DTC124E S-T
D1009	D13TDS442X	DIODE, SILICON DS442X-BT	Q2006	TN7TC03001	COMPOUND, TRANSISTOR DTC124E S-T
D2001	D13TGMA010	DIODE, SILICON GMA-01-BT	Q2007	TN7TD03001	COMPOUND, TRANSISTOR DTC144E S-T
D2002	D13TGMA010	DIODE, SILICON GMA-01-BT	Q2501	TA3T0984K0	TRANSISTOR, SILICON 2SA984K-T
D2003	D13TGMA010	DIODE, SILICON GMA-01-BT	Q2503	TN7TB03001	COMPOUND, TRANSISTOR DTC114E S-T
D2004	D13TGMA010	DIODE, SILICON GMA-01-BT	Q2504	TN7TB03001	COMPOUND, TRANSISTOR DTC114E S-T
D2005	D13TGMA010	DIODE, SILICON GMA-01-BT	△ Q2505	TD30018250	TRANSISTOR, SILICON 2SD1825
D2007	D13TGMA010	DIODE, SILICON GMA-01-BT	Q2506	TD3T007340	TRANSISTOR, SILICON 2SD734-T
D2008	D13TGMA010	DIODE, SILICON GMA-01-BT	Q3001	TC3T0536S0	TRANSISTOR, SILICON 2SC536SP-AC
D2009	D13TDS442X	DIODE, SILICON DS442X-BT	Q3002	TC3T0536S0	TRANSISTOR, SILICON 2SC536SP-AC
D2010	D13TGMA010	DIODE, SILICON GMA-01-BT	Q3003	TP7TC03001	COMPOUND, TRANSISTOR DTA124E S-T
D2014	D13TGMA010	DIODE, SILICON GMA-01-BT	Q3004	TN7TC03001	COMPOUND, TRANSISTOR DTC124E S-T
D2015	D130GMA010	DIODE, SILICON GMA-01	Q4001	TC3T0536S0	TRANSISTOR, SILICON 2SC536SP-AC
D2016	D13TGMA010	DIODE, SILICON GMA-01-BT	Q4002	TC3T0536S0	TRANSISTOR, SILICON 2SC536SP-AC
D2017	D13TGMA010	DIODE, SILICON GMA-01-BT	Q4003	TC3T0536S0	TRANSISTOR, SILICON 2SC536SP-AC
D2018	D13TGMA010	DIODE, SILICON GMA-01-BT	Q4004	TN7D03001	COMPOUND, TRANSISTOR DTC144E S-T
D2019	D13TGMA010	DIODE, SILICON GMA-01-BT	Q4005	TA3T0608S0	TRANSISTOR, SILICON 2SA608SP-AC
D2020	D13TGMA010	DIODE, SILICON GMA-01-BT	Q4006	TN7D03001	COMPOUND, TRANSISTOR DTC144E S-T
D2021	D13TGMA010	DIODE, SILICON GMA-01-BT	Q4007	TN7TC03001	COMPOUND, TRANSISTOR DTC124E S-T
△ D2501	D28T011E20	DIODE, SILICON 11E2TA1	Q4008	TC3T0536S0	TRANSISTOR, SILICON 2SC536SP-AC
△ D2502	D28T011E20	DIODE, SILICON 11E2TA1	Q4101	TC3T0536S0	TRANSISTOR, SILICON 2SC536SP-AC
D2503	DB772MR150	DIODE, GLASS SEALED LED LTZ-MR15-T77	Q4102	TC3T0536S0	TRANSISTOR, SILICON 2SC536SP-AC
D2505	D93012701C	DIODE, ZENER GZB27C	Q4103	TC3T0536S0	TRANSISTOR, SILICON 2SC536SP-AC
△ D2508	D28T011E10	DIODE, SILICON 11E1TA1-T	Q4201	TC3T0536S0	TRANSISTOR, SILICON 2SC536SP-AC
△ D2509	D28T011E10	DIODE, SILICON 11E1TA1-T	Q4202	TC3T022740	TRANSISTOR, SILICON 2SC2274
			Q4203	TN7TC03001	COMPOUND, TRANSISTOR DTC124E S-T

## ELECTRICAL REPLACEMENT PARTS LIST

REF. NO	PARTS. NO	DESCRIPTION	REF. NO	PARTS. NO	DESCRIPTION
-SEMICONDUCTORS (CONT)-			-SWITCHES (CONT)-		
Q4204	TN7TD03001	COMPOUND, TRANSISTOR DTC144E S-T	SW611	0504101008	SWITCH TACT EVQ-QR205K
Q4205	TN7TD03001	COMPOUND, TRANSISTOR DTC144E S-T	SW612	0504101008	SWITCH TACT EVQ-QR205K
Q4206	TN7TD03001	COMPOUND, TRANSISTOR DTC144E S-T	SW613	0504101008	SWITCH TACT EVQ-QR205K
Q4207	TN7TC03001	COMPOUND, TRANSISTOR DTC124E S-T	SW614	0504101008	SWITCH TACT EVQ-QR205K
Q4208	TA3T0608K0	TRANSISTOR, SILICON 2SA608KNP-T	SW615	0504101008	SWITCH TACT EVQ-QR205K
Q4209	TN7TD03001	COMPOUND, TRANSISTOR DTC144E S-T	SW616	0504101008	SWITCH TACT EVQ-QR205K
Q5001	TN7TC03001	COMPOUND, TRANSISTOR DTC124E S-T	SW617	0504101008	SWITCH TACT EVQ-QR205K
Q5003	TN7TC03001	COMPOUND, TRANSISTOR DTC124E S-T	SW618	0504101008	SWITCH TACT EVQ-QR205K
Q5004	TN7TC03001	COMPOUND, TRANSISTOR DTC124E S-T	SW619	0504101008	SWITCH TACT EVQ-QR205K
Q5005	TN7TC03001	COMPOUND, TRANSISTOR DTC124E S-T	SW620	0504101008	SWITCH TACT EVQ-QR205K
Q5006	TA7T011980	TRANSISTOR, SILICON 2SA1198-T93	SW621	0504101008	SWITCH TACT EVQ-QR205K
Q5007	TC7T023900	TRANSISTOR, SILICON 2SC2390-T93	SW622	0504101008	SWITCH TACT EVQ-QR205K
Q5008	TC7T023900	TRANSISTOR, SILICON 2SC2390-T93	SW623	0504101008	SWITCH TACT EVQ-QR205K
Q5009	TC10013170	TRANSISTOR, SILICON 2SC1317	SW624	0504101008	SWITCH TACT EVQ-QR205K
Q6001	TA3T0608S0	TRANSISTOR, SILICON 2SA608SP-AC	SW625	0504101008	SWITCH TACT EVQ-QR205K
Q6002	TC3T0536S0	TRANSISTOR, SILICON 2SC536SP-AC	SW626	0504101008	SWITCH TACT EVQ-QR205K
Q6003	TC5T0388A0	TRANSISTOR, SILICON 2SC388A	SW627	0504101008	SWITCH TACT EVQ-QR205K
Q6004	TN7TC03001	COMPOUND, TRANSISTOR DTC124E S-T	SW628	0504101008	SWITCH TACT EVQ-QR205K
Q6005	TB3T006980	TRANSISTOR, SILICON 2SB698-T	SW629	0504101008	SWITCH TACT EVQ-QR205K
Q6006	TB3T006980	TRANSISTOR, SILICON 2SB698-T	SW630	0504101008	SWITCH TACT EVQ-QR205K
Q6007	TB3T006980	TRANSISTOR, SILICON 2SB698-T	SW631	0504101008	SWITCH TACT EVQ-QR205K
Q6008	TC3T0536S0	TRANSISTOR, SILICON 2SC536SP-AC	SW632	0504101008	SWITCH TACT EVQ-QR205K
			SW633	0504101008	SWITCH TACT EVQ-QR205K
			SW634	0504101008	SWITCH TACT EVQ-QR205K
-COILS & TRANSFORMERS-			-VARIABLE RESISTORS-		
L2001	021673101K	COIL EL0606RA-101K 100 UH	VR601	V014024B01	VR, ROTARY EVU-F3AM20B24
L3001	021JA6390K	COIL LAL02T390K-T 39 UH TA	VR602	V014025B01	VR, ROTARY EVU-F3AM20B25
L3002	021JA6221K	COIL LAL02T221K-T 220 UH TA	VR2001	V1163Q5B02	VR, SEMI FIXED EVN-D4AA00B05
L3003	021673331K	COIL EL0606RA-331K 330 UH	VR2002	V116315B02	VR, SEMI FIXED EVN-D4AA00B15
L3004	021JA6101K	COIL LAL02T101K-T 100 UH TA	VR4001	V1263Q2B01	VR, SEMI FIXED RHEOAS20FB(H0615C105)
L3005	021673101K	COIL EL0606RA-101K 100 UH	VR4101	V126213B01	VR, SEMI FIXED RHEON1308B(H0614C207)
L3006	021JA2101K	COIL LAL03TA101K 100 UH	VR4102	V1262H3B01	VR, SEMI FIXED RHEONJ306B(H0614C209)
L3007	021JA66R8K	COIL LAL02T6R8K-T 6.8 UH TA	VR5001	V126314B01	VR, SEMI FIXED RHEOA140FB(H0615C113)
L4001	021JA6100K	COIL LAL02T100K-T 10 UH TA	VR5002	V1263Q5B03	VR, SEMI FIXED RH0624CS5J
L4002	021JA6100K	COIL LAL02T100K-T 10 UH TA	VR6001	V116314B02	VR, SEMI FIXED EVN-D4AA00B14
L4003	021673101K	COIL EL0606RA-101K 100 UH	VR6002	V116314B02	VR, SEMI FIXED EVN-D4AA00B14
L4004	021JA6121K	COIL LAL02T121K-T 120 UH TA			
L4010	021JA6470K	COIL LAL02T470K-T 47 UH TA			
L4011	021JA6470K	COIL LAL02T470K-T 47 UH TA			
L4013	021JA6121K	COIL LAL02T121K-T 120 UH TA			
L4014	021673101K	COIL EL0606RA-101K 100 UH			
L4101	021JA65R6K	COIL LAL02T5R6K-T 5.6 UH TA	PCB101	13VV0041A1	PCB VV0041A
L4104	021673101K	COIL EL0606RA-101K 100 UH	PCB301	13VV0042A1	PCB VV0042A
L4105	021JA6470K	COIL LAL02T470K-T 47 UH TA	PCB302	13VE0121A1	PCB VE0121A
L4106	021JA6150K	COIL LAL02T150K-T 15 UH TA	PCB501	13VP0032A1	PCB VP0032A
L4107	021JA6330K	COIL LAL02T330K-T 33 UH TA	PCB502	13VE0119A1	PCB VE0119A
L4108	021673101K	COIL EL0606RA-101K 100 UH	PCB601	13VE0120A1	PCB VE0120A
L4109	021JA65R6K	COIL LAL02T5R6K-T 5.6 UH TA	PCB602	13VE0118A1	PCB VE0118A
L4201	021JA6151K	COIL LAL02T151K-T 150 UH TA	PCB603	13VC0061A1	PCB VC0061A
L4202	021JA6101K	COIL LAL02T101K-T 100 UH TA			
L4203	021673101K	COIL EL0606RA-101K 100 UH			
L5001	021673102K	COIL EL0606RA-102K 1000 UH	BT601	1412004001	BATTERY, MANGAN UM-4(SP)
L5002	021663102K	COIL EL0606SKI-102K 1000 UH	△ CD501	1201410307	CORD AC BUSH U2N 7FEET DAIWA
L5003	021679682J	COIL EL0909RR-682J 6.8 MH	△ CD502	068301115A	CORD CONNECTOR 8301115A
L6001	021JA65R6K	COIL LAL02T5R6K-T 5.6 UH TA	△ CD503	068313107A	CORD EIS CONNECTOR 8313107A
L6002	021JA6330K	COIL LAL02T330K-T 33 UH TA	CP501	0694180060	CONNECTOR PCB SIDE 172681-8 UX-V
L6003	021JA6100K	COIL LAL02T100K-T 10 UH TA	CX607	069R180149	CONNECTOR BRIDGE 5110-08K
L6004	021JA6150K	COIL LAL02T150K-T 15 UH TA	CY601	0694270030	CONNECTOR PCB SIDE 173991-7
L6005	021JA61R2M	COIL LAL02T1R2M-T 1.2 UH TA	CY602	0694270030	CONNECTOR PCB SIDE 173991-7
L6007	021JA6R56M	COIL LAL02TR56M-T 0.56 UH TA	CY603	0694270030	CONNECTOR PCB SIDE 173991-7
L6008	021673101K	COIL EL0606RA-101K 100 UH	CY604	0694270030	CONNECTOR PCB SIDE 173991-7
L6010	0336020068	COIL VIDEO IFT 3602006	CY605	069R180159	CONNECTOR PCB SIDE 5224-08CHPB
L6011	0336020058	COIL VIDEO IFT 3602005	CY606	069R180159	CONNECTOR PCB SIDE 5224-08CHPB
△ T501	0401570043	TRANSFORMER, POWER AC 0157004	CD2001	068319029A	CORD EIS CONNECTOR 8319029A
T5001	031C160018	COIL, BIAS OSC 1C16001	CD2002	068317085A	CORD EIS CONNECTOR 8317085A
T5002	031C160028	COIL, BIAS OSC 1C16002	CD2501	068318038A	CORD EIS CONNECTOR 8318038A
-JACK & CONNECTORS-			CD2502	1227033201	CORD JUMPER 27033201
J4001	0632000012	JACK PLATE JPJ0766-01-010	CD2503	068301102A	CORD EIS CONNECTOR 8301102A
J6001	063Q000013	JACK PLATE VVEA0990-9011	CD4101	068319028A	CORD EIS CONNECTOR 8319028A
-SWITCHES-			CD6001	0682H06001	CORD COAXIAL 82H06001
SW601	0504101008	SWITCH TACT EVQ-QR205K	CD6003	0680L05003	CABLE-F CFJP75-300-4
SW602	0504101008	SWITCH TACT EVQ-QR205K	CD6004	122022F002	CORD FEEDER P300-01
SW603	0504101008	SWITCH TACT EVQ-QR205K	CD6005	0630200006	PLUG-FJ CFJP02
SW604	0504101008	SWITCH TACT EVQ-QR205K	CF6001	1028045R71	FILTER, SAW TSF1203C
SW605	0504101008	SWITCH TACT EVQ-QR205K	CF6002	101224R503	FILTER, CERAMIC DISCRIMINATOR CDA4.5MC26
SW606	0504101008	SWITCH TACT EVQ-QR205K	CF6003	1012004R53	FILTER, CERAMIC SFE4.5MBF
SW607	0504101008	SWITCH TACT EVQ-QR205K	CF6004	1012104R53	FILTER, CERAMIC TRAP TPS4.5MB
SW608	0504101008	SWITCH TACT EVQ-QR205K	CP1001	0694180060	CONNECTOR PCB SIDE 172681-8 UX-V
SW609	0504101008	SWITCH TACT EVQ-QR205K	CP2001	0694120060	CONNECTOR PCB SIDE 172681-2
SW610	0504101008	SWITCH TACT EVQ-QR205K	CP2003	069R7E0029	CONNECTOR PCB SIDE 5597-14CPB
			CP4001	069RFA0040	CONNECTOR PIN 5530-10B
			CP4002	069RF60040	CONNECTOR PIN 5530-06B
			CP4003	069RF70040	CONNECTOR PIN 5530-07B
			CP4004	069RF60040	CONNECTOR PIN 5530-06B
			CP4101	069R250099	CONNECTOR PCB-PCB 53027-0510
			CP4102	0694190070	CONNECTOR PCB SIDE 172683-9

## ELECTRICAL REPLACEMENT PARTS LIST

REF.NO	PARTS.NO	DESCRIPTION	
-MISCELLANEOUS (CONT)-			
CP5001	0694150060	CONNECTOR PCB SIDE	172681-5 UX-V
CX1001	0694270040	CONNECTOR PCB SIDE	173992-7
CX1002	0694270040	CONNECTOR PCB SIDE	173992-7
CX1003	0694270040	CONNECTOR PCB SIDE	173992-7
CX1004	0694270040	CONNECTOR PCB SIDE	173992-7
DL4001	104113R573	DELAY LINE GLASS	EFD-KD645A32J
△ F501	0802C1R603	FUSE	23501.6
△ F502	0802C1R603	FUSE	23501.6
△ F503	0802C01003	FUSE	235001
FH501	067H000003	HOLDER.FUSE	773JEE0004
ICP201	084700R402	IC PROTECTOR	ICP-N10
LC4101	117B320001	LC COMPOUND	37-0001
OS601	0771006001	REMOTE RECEIVER	EUR-3692
PF3001	1147L14601	FILTER LOW PASS	47L14601
PF3002	1147B35604	FILTER BAND PASS	47B35604
PF3003	1147B42603	FILTER BAND PASS	47B42603
PF4001	1147L30604	FILTER LOW PASS	47L30604
PF4101	1147H14606	FILTER HIGH PASS	47H14606
PF5001	032623001A	COIL TRAP	2623001
RN1001	110E447202	R.NETWORK	RN3H5A472J
RN1002	110E522302	R.NETWORK	RN3H6A223J
RN1003	110E322302	R.NETWORK	RN3H4A223J
RN1004	110E422304	R.NETWORK	RN3H5A223J
TC601	0100514001	C.CERAMIC TRIMMER	TZ03R300E
TM601	0761080002	TRANSMITTER	EUR53421
TU6001	0145700007	TUNER.UHF-VHF	UVE30-A11
△ TU6002	0150700002	RF CONVERTER	MDF8-VA3422
V601	096270R302	TUBE FLUORSCENT DISPLAY	FIP11SM7
X601	10064R1903	CRYSTAL DSM AT	4.19MHZ
X602	100632R801	CRYSTAL DSVT-200	32.76KHZ
X1001	100D4R0002	CERAMIC OSCILLATOR	PRS-4.00RM
X3001	10063R5703	CRYSTAL	VSX0160

## CAPACITOR

CC.....CERAMIC CAPACITOR  
 CE.....ALUMI ELECTROLYTIC CAPACITOR  
 CPP.....POLYPROPYLENE CAPACITOR  
 CPL.....PLASTIC CAPACITOR  
 CMPL.....METAL PLASTIC CAPACITOR

## RESISTOR

RC.....CARBON RESISTOR

DECK REPLACEMENT PARTS LIST

REF. NO	PARTS. NO	DESCRIPTION	REF. NO	PARTS. NO	DESCRIPTION	
301	850P600116	POST STOPPER L	416	850P900243	WORM WHEEL	
302	850A400040	GUIDE ROLLER ASS'Y	417	788JKE0005	TAP TITE(P) PAN W7.5	2.6*10 UC
303	850A400038	INCLINED BASE S ASS'Y	418	850P900239	LEVER CAM	
304	850P600117	POST STOPPER R	419	850A900045	BRACKET, MOTOR ASS'Y	
305	850A300018	LOADING ARM L ASS'Y	420	850P900245	WORM	
306	850P800083	SPRING, LOADING GEAR L	421	850P900251	BRACKET, SIDE L	
307	850P300055	GEAR, LOADING L	422	850P900252	BRACKET, SIDE R	
308	850A400039	INCLINED BASE R ASS'Y	423	850A900044	CASS. HOLDER SUB ASS'Y	
309	850P600113	PULLEY, LOADING MOTOR	424	850P900244	CLUTCH GEAR	
310	850A300019	LOADING ARM R ASS'Y	425	850P900257	SPRING CASS. HOLDER	
311	850P800084	SPRING, LOADING GEAR R	426	850P900271	PLATE, EARTH L	
312	850P300056	GEAR, LOADING R	427	850P900248	TAPE GUIDE PIECE	
313	850A100006	LOADING BASE ASS'Y	428	850P900273	SPRING, LEVER CAM (A)	
314	850P800071	SPRING, AZIMUTH	429	850P900217	WORM DRIVER	
315	868X0HH804	CONEHEAD SCREW				M3*8 CH
316	868512HA34	JOINT SCREW BIND	430	850P900264	SPRING, LOCKER R	
317	850A500003	AC HEAD BASE ASS'Y	431	850P900242	REMOVING	
318	850P800070	SPRING, AC HEAD BASE				
319	850P800077	SPRING, PINCH ROLLER	501	868022D404	BIND	M2*4 CH
320	850A400041	PINCH ROLLER ARM ASS'Y	502	8680K1G604	SEMS K	M2.6*6 CH
321	850A400044	LIMITER POST ARM ASS'Y	503	8680B1HA04	SEMS B	M3*10 CH
322	850P800073	SPRING, LIMITER POST	504	868072H404	TAP TITE(S) BIND	3*4 CH
323	850P500010	ADJUST NUT	505	868072H604	TAP TITE(S) BIND	3*6 CH
324	850P600139	POST, SLEEVE 2	506	868072H804	TAP TITE(S) BIND	3*8 CH
325	850P800076	SPRING, P4	507	868072HA04	TAP TITE(S) BIND	3*10 CH
326	850A700003	LED HOLDER ASS'Y	508	868072HA44	TAP TITE(S) BIND	3*14 CH
327	850A600049	TB BRAKE ARM ASS'Y	509	868073H604	TAP TITE(S) FLAT	3*6 CH
328	850A200007	REEL DISK T ASS'Y	510	8685DZD302	SET SCREW 6CUP POINT	M2*3 BK
329	850P800079	SPRING, SS BRAKE	511	868102H804	TAP TITE(P) BIND	3*8 CH
330	850A600037	SS BRAKE ARM ASS'Y	512	867072HA85	TAP TITE(S) BIND	3*18 UC
331	850P800081	SPRING, TENSION LEVER 2	513	868501H804	TAP TITE(S) PAN W6	3*8 CH
332	850A600047	TENSION LEVER 2 ASS'Y	514	868NETW251	E-RING	2.5
333	850A200004	IDLER ASS'Y	515	868NETW301	E-RING	3.0
334	850A200006	REEL DISK S ASS'Y	516	868N008304	NYLON NUT	M3
335	850A600041	MAIN BRAKE ARM L ASS'Y	517	868N007304	NYLON NUT	M3
336	850A600042	MAIN BRAKE ARM R ASS'Y	518	868WA32A0U	WASHER	3.2*10*TO.8
337	850P800074	SPRING, MAIN BRAKE	519	868WA4380Q	WASHER	4.3*8.0*TO.5
338	850A600044	MB CONNECT ASS'Y	520	868WP2647E	POLYSLIDER WASHER	2.6*4.7*TO.13
339	850P800082	SPRING, TS BRAKE	521	868WP3144E	POLYSLIDER WASHER	3.1*4.4*TO.13
340	850A600038	TS BRAKE ARM ASS'Y	522	868WP3144J	POLYSLIDER WASHER	3.1*4.4*TO.25
341	850P600130	POST, SLEEVE P1	523	868WP3147J	POLYSLIDER WASHER	3.1*4.7*TO.25
342	850P800075	SPRING, P1	524	868WP6290Q	POLYSLIDER WASHER	4.2*9.0*TO.5
343	850P800072	SPRING, FE HEAD ARM	525	868WP6290U	POLYSLIDER WASHER	6.2*9.0*TO.8
344	850A600045	TENSION BAND ASS'Y	526	868WQ2647N	POLYSLIDER WASHER(CUT)	2.6*4.7*TO.4
345	850P800080	SPRING, TENSION ARM	527	868WQ3154N	POLYSLIDER WASHER(CUT)	3.1*5.4*TO.4
346	850A400043	TENSION ARM ASS'Y	528	868072H504	TAP TITE(S) BIND	3*5 CH
347	850A500004	FE HEAD ARM ASS'Y	529	868WP3170J	POLYSLIDER WASHER	3.1*7.0*TO.25
348	850P600120	PLATE, ADJUST TENSION	550	868101G604	TAP TITE(P) PAN	2.6*6
349	850P000092	FRAME, DECK BACK	551	8680A1H404	SEMS A	M3*4 CH
350	850P600142	ACTUATOR, PINCH ROLLER	553	868WP3254Q	POLYSLIDER WASHER	3.2*5.4*TO.5
351	850P800078	SPRING, PR ACTUATOR	---	850P600111	HOLDER, PHOTO COUPLER	
352	850A000007	MAIN CHASSIS ASS'Y	---	8995167000	BAND, CORD CLAMP	
353	850A600046	WORM ASS'Y	CD1001	068318036B	CORD EIS CONNECTOR	8318036B
354	850P600125	BELT, LOADING MOTOR	CD2003	12270E2301	CORD JUMPER	270E2301
355	850P600141	MAIN CAM	CD5001	068315061A	CORD EIS CONNECTOR	8315061A
356	850A600048	TENSION LEVER 1 ASS'Y	CD5002	068312155A	CORD EIS CONNECTOR	8312155A
357	850A300020	FAN SHAPED GEAR ASS'Y	CD5003	068312156A	CORD EIS CONNECTOR	8312156A
358	850P600118	PLATE, FS GEAR	CP1103	069R7E0019	CONNECTOR PCB SIDE	5597-14APB
359	850A200005	CLUTCH ASS'Y	D1102	DAK0000070	DEW SENSOR	HDP-03-CLSL
360	850A600040	MAIN BRAKE LEVER ASS'Y	H5001	1523D91004	HEAD, AUDIO CONTROL	HVMLA1023A
361	850A600043	CA LEVER ASS'Y	H5002	1543D02002	HEAD, FULL ERASE	HVFMD0009
362	850A600036	ACTUATOR ASS'Y	L1501	02BL000005	ELECTRO MAGNET	JTM1002-01
363	850A600039	LIMITER POST LEVER ASS'Y	M101	1596978001	MOTOR, LOADING	MXN-13BD11A
364	850P300059	GEAR, M	M2001	1510398002	CAPSTAN DD UNIT	F2RKB04
365	850P600129	FLANGE, P1(B)	M2002	1596958001	MOTOR, LOADING	MXN-12AD12F
366	850P600122	NUT, ADJUST X	PCB102	13VE0123A2	PCB	VE0123A
368	850P600124	BELT, REEL	PCB103	13VE0125A2	PCB	VE0125A
370	850P600128	FLANGE, P1(A)	PCB111	13VE0124A2	PCB	VE0124A
371	850P000069	FRAME, RIGHT SIDE	PT1001	1261000004	LUG PIN	21009
373	850P600134	BAND, LOADING MOTOR	Q1101	0000800010	TRANSISTOR, PHOTO	PT361
374	850P100029	HOLDER ANGLE	Q1102	0000800010	TRANSISTOR, PHOTO	PT361
401	850P900258	SPRING, REMOVING	Q1510	0002G00020	PHOTO COUPLER	6P2S09AB
402	850P900256	BRACKET TOP	R1001	R01116103J	RC ERD-16TJ103A	10K OHM 1/6W
403	850P900261	SPRING, LINK GEAR L	SW101	0550111012	SWITCH, LEAF	LSA-1121-9AU
404	850P900246	LINK GEAR L	SW102	0520343001	SWITCH, ROTARY	HMW0423-01
405	850P900238	GEAR, SYNCHRO	SW103	0550A22003	SWITCH, LEAF	MCV00010MPHO
406	850A900047	CASS, SIDE L ASS'Y	UN4001	1590D00019	UNIT, CYLINDER	CYP2N009A
407	850P900267	SHAFT, SYNCHRO				
408	850P900240	OPENER				
409	850P900263	SPRING, OPENER				
410	850A900055	CASS SIDE R ASS'Y				
411	850P900241	FLAP OPENER				
412	850P900259	SPRING, FLAP OPENER				
413	850P900247	LINK GEAR R				
414	850P900260	SPRING, CLUTCH				
415	850P900262	SPRING, LINK GEAR R				

MECHANICAL REPLACEMENT PARTS LIST

REF. NO	PARTS. NO	DESCRIPTION	REF. NO.	DESCRIPTION	DESCRIPTION
601	702JSS0021	CABINET, TOP	Q4001	2SC536SP-AC	2SC1740SP-T
	7232560061	FILM, DECORATION	Q4002	2SC536SP-AC	2SC1740SP-T
602	752JSA0192	PLATE, HEAD SHIELD	Q4003	2SC536SP-AC	2SC1740SP-T
603	752JSA0187	HEAD AMP SHIELD BOX A	Q4005	2SA608SP-AC	2SA933S-T
604	752JSA0188	HEAD AMP SHIELD BOX B	Q4007	DTC124E S-T	2SC3400-T
605	752JSA0186	FRAME, HEAD AMP SHIELD	Q4008	2SC536SP-AC	2SC1740SP-T
606	7230001319	FLAP	Q4101	2SC536SP-AC	2SC1740SP-T
607	A41902723	CABINET, FRONT ASS'Y	Q4102	2SC536SP-AC	2SC1740SP-T
	701JPJ0462	CABINET, FRONT	Q4103	DTC124E S-T	2SC3400-T
	713JPA0082	GLASS, LED	Q4105	2SC536SP	2SC1740SP
	7230001261	PLATE, RECEIVER	Q4201	2SC536SP-AC	2SC1740SP-T
	7230001262	PLATE, CLOCK	Q4203	DTC124E S-T	2SC3400-T
	7230001320	PRATE, FRONT	Q4207	DTC124E S-T	2SC3400-T
	7240000287	SHEET, OPERATION	Q5001	DTC124E S-T	2SC3400-T
608	735JPD0169	BUTTON, EJECT	Q5003	DTC124E S-T	2SC3400-T
609	735JPD0168	BUTTON, POWER	Q5004	DTC124E S-T	2SC3400-T
	713JPA0015	GLASS, LED	Q5005	DTC124E S-T	2SC3400-T
			Q6002	2SC536SP-AC	2SC1740SP-T
610	730JPA0028	BUTTON, DECK (REC.)	Q6004	DTC124E S	2SC3400
611	735JPD0167	BUTTON, DECK (PLAY)	Q6008	2SC536SP-AC	2SC1740SP-T
612	735JPD0166	BUTTON, DECK (STOP)	D503	DSF-10B-BT	11E1TA1-T
614	735JPD0170	BUTTON, CHANNEL	D504	DSF-10B-BT	11E1TA1-T
615	757JPA0001	HOLDER, DOOR	D505	DSF-10B-BT	11E1TA1-T
616	712JPJ0212	DOOR	D506	DSF-10B-BT	11E1TA1-T
	7230001291	SHEET, DOOR	D507	DSF-10B-BT	11E1TA1-T
617	735JPA0334	BUTTON, FUNCTION	D508	DSF-10B-BT	11E1TA1-T
618	730JPA0029	BUTTON, DECK (L)	D509	DSF-10B-BT	11E1TA1-T
619	742JUA0018	SPRING, BUTTON (B)	D510	DSF-10B-BT	11E1TA1-T
620	702JPA0210	CABINET, INSIDE	D1001	GMA01-BT	1SS132T-77
	704JVA0006	FELT, PAD	D1002	GMA01-BT	1SS132T-77
	7220000136	SHEET, DATE	D1003	GMA01-BT	1SS132T-77
	7220000207	SHEET, SERIAL	D1004	GMA01-BT	1SS132T-77
	7222560128	SHEET, RATING	D1005	11E1TA1-T	DSF-10B-BT
	7240000293	SHEET, FUSE	D1006	11E1TA1-T	DSF-10B-BT
621	755JNA0022	COVER, FUSE	D1008	GMA01-BT	1SS132T-77
622	763JEA0008	ANGLE, TRANS	D2001	GMA01-BT	1SS132T-77
623	771JPA0069	PLATE, JACK	D2002	GMA01-BT	1SS132T-77
624	763JAE0019	HEAT SINK	D2003	GMA01-BT	1SS132T-77
625	702JSA0011	PLATE, BOTTOM	D2004	GMA01-BT	1SS132T-77
626	8990006024	STYLE PIN DIA 1	D2005	GMA01-BT	1SS132T-77
627	800JFA0013	FC SHEET	D2007	GMA01-BT	1SS132T-77
628	788JSE0014	TAPPING (BO) TRUSS	D2008	GMA01-BT	1SS132T-77
			D2010	GMA01-BT	1SS132T-77
			D2014	GMA01-BT	1SS132T-77
			D2016	GMA01-BT	1SS132T-77
			D2018	GMA01-BT	1SS132T-77
			D2019	GMA01-BT	1SS132T-77
			D2020	GMA01-BT	1SS132T-77
			D2021	GMA01-BT	1SS132T-77
			D2505	GZB27C	H227CP
			D2508	11E1TA1-T	DSF-10B-BT
			D2509	11E1TA1-T	DSF-10B-BT
			D2510	GMA01-BT	1SS132T-77
			D3001	GMA01-BT	1SS132T-77
			D3002	GMA01-BT	1SS132T-77
			D3003	GMA01-BT	1SS132T-77
			D4001	GMA01-BT	1SS132T-77
			D4002	GMA01-BT	1SS132T-77
			D4003	GMA01-BT	1SS132T-77
			D4005	GMA01-BT	1SS132T-77
			D4201	GMA01-BT	1SS132T-77
			D4202	RD13EB	GZA13
			D6002	GMA01-BT	1SS132T-77
			VR2001	EVN-D4AA00BQ5	H0615C123470KB
			VR2002	EVN-D4AA00B15	H0615C119100KB
			VR5001	H0615C11310KB	EVN-D4AA00B14
			VR6001	EVN-D4AA00B14	H0615C11310KB
			VR6002	EVN-D4AA00B13	H0615C1071KB
			L6010	3602006	3602006
				(0336020068)	(0336020067)
			L6011	3603005	3602005
				(0336020058)	(0336020057)
			T501	0157004	0157004
				(0401570043)	(0401570041)
			DL4001	EFDKD645A32J	ADL-CN1246R
				(104113R573)	(104A13R573)
			F501	23501.6	GG5-1.6
			F502	23501.6	GG5-1.6
			F503	235001	GG5-1
			PF3001	47L30601	41B42603
			PF3002	47B35604	41B35604
			PF3003	47B42603	41B42603
			PF4001	47L30604	41L30604
			RN1001	RN3H5A472J	RYLS4J472
			RN1002	RN3H6A223J	RYLS5J223
			RN1003	RN3H4A223J	RYLS3J223
			RN1004	RN3H5A223J	RYLS4J223
			TU6001	UVE30-A11	EC-CU-0288
				(0245700007)	(0145200007)
			TU6002	MDF8-VA3422	115-M-1301AE
				(0150700002)	(0150300001)
			X601	DSM AT	CSA-309
			X1001	PRS-4.00RM	CSA4.00MG
Q601	DTC114E S-T	2SC3402-T			
Q602	DTC114E S-T	2SC3402-T			
Q603	DTC114E S-T	2SC3402-T			
Q604	DTC114E S-T	2SC3402-T			
Q1002	DTC124E S-T	2SC3400-T			
Q1004	DTC124E S-T	2SC3400-T			
Q1007	DTC124E S-T	2SC3400-T			
Q2001	2SC536SP-AC	2SC1740SP-T			
Q2005	DTC124E S-T	2SC3400-T			
Q2006	DTC124E S-T	2SC3400-T			
Q2503	DTC114E S-T	2SC3402-T			
Q2504	DTC114E S-T	2SC3402-T			
Q3002	2SC536SP-AC	2SC1740SP-T			

INTERCHANGEABLE PARTS LIST

NOTE: THE FOLLOWING PART(S) MAY BE SUBSTITUTED FOR PARTS INDICATED IN THE BASIC PART(S) LIST (WITH THE SAME REF. NO.). THESE PARTS SHARE THE SAME ELECTRICAL CHARACTERISTICS AND OTHER ELEMENTS FOR COMMON USAGE. EITHER PART NUMBER MAY BE USED IN THIS UNIT.

REF. NO.	DESCRIPTION	DESCRIPTION
Q601	DTC114E S-T	2SC3402-T
Q602	DTC114E S-T	2SC3402-T
Q603	DTC114E S-T	2SC3402-T
Q604	DTC114E S-T	2SC3402-T
Q1002	DTC124E S-T	2SC3400-T
Q1004	DTC124E S-T	2SC3400-T
Q1007	DTC124E S-T	2SC3400-T
Q2001	2SC536SP-AC	2SC1740SP-T
Q2005	DTC124E S-T	2SC3400-T
Q2006	DTC124E S-T	2SC3400-T
Q2503	DTC114E S-T	2SC3402-T
Q2504	DTC114E S-T	2SC3402-T
Q3002	2SC536SP-AC	2SC1740SP-T