

MX-100

EPSON DOT MATRIX PRINTER

Technical Manual

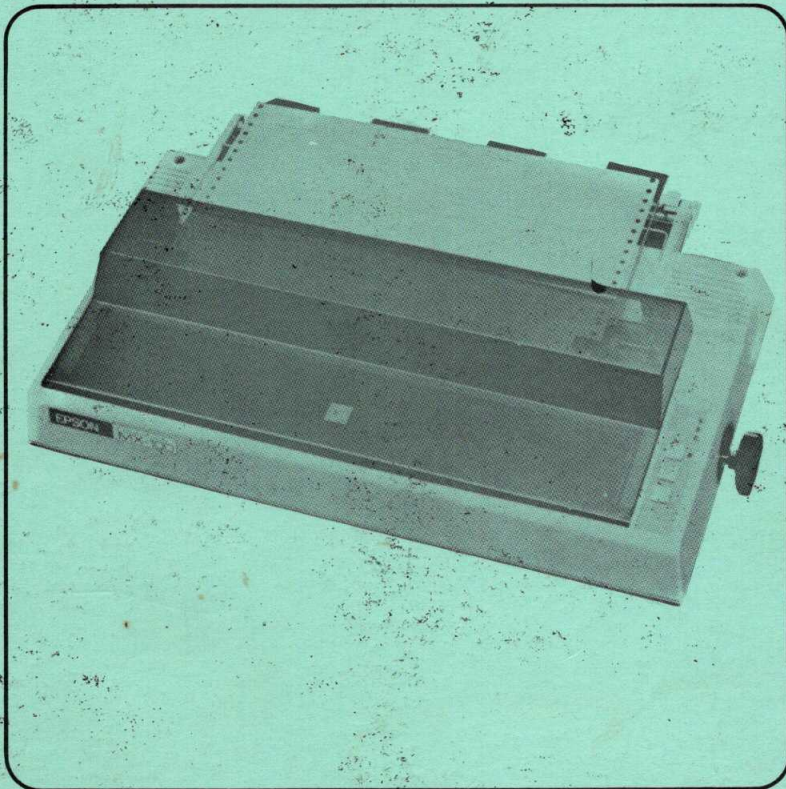

EPSON

P8190033
REV. A

INTRODUCTION

This technical manual describes the principles of mechanical and electrical operations, as well as the maintenance and repair procedures, of the EPSON MX-100 Dot Matrix Printer, to permit the user to understand its functions and thereby to allow the Printer to fully display its rated performance.

Chapters 3 through 5 of the manual deal with the fundamental troubleshooting, maintenance and repair of the MX-100, and Chapter 6, a simple quick troubleshooting procedure on the basis of a block-to-block replacement. For details on the disassembly, assembly, troubleshooting and maintenance of the M-3360 Printer Mechanism, refer to the separately published "Technical Manual of EPSON Model 3360."

*The contents of this manual are subject to change without notice.

EPSON
SHINSHU SEIKI CO., LTD.

"All rights reserved."
80 HIROOKA SHIOJIRI-CITY NAGANO JAPAN

REV. A

TABLE OF CONTENTS

CHAPTER 1 GENERAL

1.1 Features of MX-100	1-1
1.2 Features of Interfaces	1-1
1.3 Serviceability	1-1
1.4 General Specifications of MX-100	1-2
1.4.1 Printer	1-2
1.4.2 Parallel Interface (Standard)	1-2
1.5 Major Components	1-3

CHAPTER 2 PRINCIPLES OF OPERATION

2.1 General	2-1
2.2 Block Diagrams	2-1
2.3 Principles of Operation	2-9
2.4 Electrical Circuits	2-9
2.5 Operating Principles of Printer Mechanism	2-23
2.5.1 Head carriage and paper feeding mechanisms	2-23
2.5.2 Print head	2-23
2.5.3 Ribbon feeding mechanism	2-34
2.5.4 Detecting mechanism	2-24
2.5.5 Frame section	2-24

CHAPTER 3 DISASSEMBLY, ASSEMBLY AND TROUBLESHOOTING

3.1 General	3-1
3.2 Tools and Measuring Instruments	3-1
3.3 Disassembly and Assembly	3-3
3.3.1 Removal of upper case	3-3
3.3.2 Disassembly of electric circuit block	3-5
3.3.3 Disassembly of M-3360 printer mechanism block	3-9
3.4 Symptoms of Trouble and Repair	3-15
3.4.1 General	3-15
3.4.2 Troubleshooting by symptom	3-16
3.4.3 Troubleshooting of control circuit board	3-20

CHAPTER 4 MAINTENANCE

4.1 General	4-1
4.2 Lubrication	4-1
4.2.1 Lubricants	4-1
4.2.2 Lubrication standards	4-1
4.2.3 Bonding Standards	4-2
4.3 Adjustments	4-4
4.3.1 Adjustment of head driving pulse width	4-4
4.3.2 Adjustment of timing pulse generating position	4-5
4.3.3 Adjustment of phase relationship between timing signal and reset signal	4-6

CHAPTER 5 CIRCUIT DIAGRAMS

5.1 General	5-1
5.2 Connection Diagrams	5-1
5.3 Component Layout Drawing	5-5

CHAPTER 6 SIMPLE TROUBLESHOOTING

6.1 General	6-1
6.2 Troubleshooting	6-1

LIST OF FIGURES

CHAPTER 1 GENERAL

Fig. 1.1	M-3360 Printer Mechanism	1-3
Fig. 1.2	Main and Driver Circuit Boards	1-3
Fig. 1.3	Power Supply Circuit	1-4
Fig. 1.4	Upper and Lower Cases	1-4

CHAPTER 2 PRINCIPLES OF OPERATION

Fig. 2.1	Flow of Signals	2-1
Fig. 2.2	Component Layout of Fuse & Filter Circuit	2-9
Fig. 2.3	Connection Diagram of Fuse & Filter Circuit	2-9
Fig. 2.4	Windings of Transformer	2-10
Fig. 2.5	Rectifier and Constant-Voltage Circuit	2-10
Fig. 2.6	Flow of Data and Signals through 8155	2-12
Fig. 2.7	8155 and Peripheral Circuits	2-12
Fig. 2.8	Data Transfer Sequence	2-13
Fig. 2.9	Carriage Stepper Motor Drive Signals (Forward)	2-13
Fig. 2.10	Paper Feed Stepper Motor Drive Signals	2-14
Fig. 2.11	8041 and Peripheral Circuits	2-15
Fig. 2.12	Signals ALE and $\overline{\text{PSEN}}$	2-16
Fig. 2.13	8049 and Program Memory Circuits	2-16
Fig. 2.14	Locations of DIP Switches	2-17
Fig. 2.15	DIP Switch Status Read Circuit	2-17
Fig. 2.16	Reset (HP Sensor) Circuit	2-18
Fig. 2.17	Timing (PTS) Sensor Circuit	2-18
Fig. 2.18	Timing and Reset Detection Signals	2-19
Fig. 2.19	Driver Circuit	2-19
Fig. 2.20	Current Waveform of Print Head	2-20
Fig. 2.21	Applied Voltage vs. Driving Pulse Width	2-20
Fig. 2.22	Switches and Indicators on Control Panel	2-21
Fig. 2.23	Switch and Indicator Control Circuit	2-22
Fig. 2.24	Operation of Print Head	2-23

LIST OF FIGURES

CHAPTER 3 DISASSEMBLY, ASSEMBLY AND TROUBLESHOOTING

Fig. 3.1	Removal of Manual Paper Feeding Knob	3-3
Fig. 3.2	Removal of 5 Screws	3-3
Fig. 3.3	Locations of Respective Components	3-4
Fig. 3.4	Dismounting of Driver Circuit Board	3-5
Fig. 3.5	Removal of Control Circuit Board	3-6
Fig. 3.6	Removal of Power Transformer	3-7
Fig. 3.7	Dismounting of Fuse and Filter Circuit Board	3-8
Fig. 3.8	Dismounting of M-3360 Printer Mechanism	3-9
Fig. 3.9	Dismounting of Print Head Unit	3-10
Fig. 3.10	Dismounting of Home Position Sensor Assy	3-10
Fig. 3.11	Unsoldering of Four Lead Wires	3-11
Fig. 3.12	Dismounting of PTS Sensor Board Assy	3-11
Fig. 3.13	Dismounting of Timing Belt Motor Assy	3-12
Fig. 3.14	Unsoldering of Lead Wires	3-13
Fig. 3.15	Dismounting of Paper Feeding Motor Assy	3-13
Fig. 3.16	Dismounting of PE Board Assy	3-14
Fig. 3.17	Normal Waveform of Signal $\overline{\text{PSEN}}$	3-20
Fig. 3.18	Normal Waveform of Signal ALE	3-20
Fig. 3.19	Normal Waveform of Signal SYNC	3-21

CHAPTER 4 MAINTENANCE

Fig. 4.1	Lube Points and Bonding Points	4-3
Fig. 4.2	Applied Voltage vs. Driving Pulse Width	4-4
Fig. 4.3	Adjustment of PTS Sensor Board	4-5
Fig. 4.4	Timing Signal PTS (Pin No. 39 of 8049)	4-5
Fig. 4.5	Adjustment of Home Position Sensor Assy	4-6
Fig. 4.6	Relationship between Timing Signal and Reset Signal	4-6

CHAPTER 5 CIRCUIT DIAGRAMS

Fig. 5.1	Connectaon Diagram of Control Circuit	5-3
Fig. 5.2	Connection Diagram of Driver Circuit	5-4
Fig. 5.3	Component Layout of Control Circuit	5-5
Fig. 5.4	Component Layout of Driver Circuit	5-6

LIST OF TABLES

CHAPTER 2 PRINCIPLES OF OPERATION

Table 2.1 Pin Assignment of CN1	2-2
Table 2.1 Pin Assignment of CN1 (cont.)	2-3
Table 2.2 Pin Assignment of CN2	2-4
Table 2.3 Pin Assignment of CN3	2-5
Table 2.4 Pin Assignment of CN4	2-6
Table 2.5 Pin Assignment of CN5	2-7
Table 2.6 Pin Assignment of CN6	2-8
Table 2.7 Signal Lines from Control Circuit to Control Panel	2-22

CHAPTER 3 DISASSEMBLY, ASSEMBLY AND TROUBLESHOOTING

Table 3.1 List of Tools	3-2
Table 3.2 List of Measuring Instruments	3-2
Table 3.3 Replaceable Circuit Components	3-15
Table 3.4 Replaceable Mechanical Components	3-15
Table 3.5 Major Components on Control Circuit Board	3-20
Table 3.6	3-21

CHAPTER 4 MAINTENANCE

Table 4.1 List of Lube Points	4-1
Table 4.2 List of Bonding Points	4-2

CHAPTER 6 SIMPLE TROUBLESHOOTING

Table 6.1 Replaceable Components in Simple Troubleshooting	6-1
--	-----

CHAPTER 1

GENERAL

CONTENTS

- 1.1 Features of MX-100 1-1
- 1.2 Features of Interfaces 1-1
- 1.3 Serviceability 1-1
- 1.4 General Specifications of MX-100 1-2
 - 1.4.1 Printer 1-2
 - 1.4.2 Parallel Interface (Standard) 1-2
- 1.5 Major Components 1-3

1.1 Features of MX-100

The MX-100 is a serial dot matrix printer featuring 80 CPS bi-directional printing with logical seeking capability and 9x9 dot-matrix character formation, and is a fruit of our constant efforts in pursuit of miniaturization, light weight and high performance. The Printer is thus capable of fully displaying its intended performance when used with various computers. The MX-100 also has optional interface boards to permit the connection of the Printer to any of the computers which are provided with various interfaces. By merely adding these optional interface boards to the MX-100, data transfer is possible between the computer and the MX-100.

1.2 Features of Interfaces

The MX-100 has a Centronics-compatible parallel interface as the standard equipment. With this standard interface, the MX-100 can be connected to any of various personal computers for data communication.

In addition to the standard interface, the MX-100 has the following interface options which permit the user to connect his Printer to almost all the computers equipped with various interfaces.

(1) RS-232C/Current Loop Serial Interface

This optional interface is of a 20 mA/60 mA current loop type which is the same as the level prescribed for serial interfaces by the EIA Standards, TTY, etc., and permits the Printer to receive data at a bit rate ranging from 75 to 9,600 BPS.

(2) IEEE 488 Interface

This optional interface has the bus structure defined by the IEEE Std. 488-1975, and permits the Printer to be connected parallelly to any computer or measuring instrument which is equipped with this bus structure. Thus, information such as measured data, etc. from the computer or measuring instrument can be recorded on the MX-100 printer.

(3) APPLE II Interface

This optional interface permits the MX-100 to transfer data to and from an APPLE II (or II Plus) personal computer manufactured by the Apple Computer Inc. when it is incorporated into the computer.

(4) TRS-80 Interface

This optional interface is connected to the bus system of a TRS-80 computer manufactured by the Tandy Radio Shack, to permit printing of the TRS-80 programs and other data on the MX-100.

As described above, the MX-100 is configured to cope with various interfaces. For further information on the respective interface options, refer to the user manual separately published for each interface.

1.3 Serviceability

The MX-100 has been designed to minimize maintenance and repair in operation under its normal use.

Should maintenance or repair be required, the printer mechanisms and circuit boards of the MX-100 are readily replaceable. Access to the respective mechanical components can be obtained easily. Accordingly, the user is permitted to perform minimum maintenance and repair with ease by referring to this manual.

1.4 General Specifications of MX-100

1.4.1 Printer

- (1) Printing Method Impact dot matrix
- (2) Character Set ASCII 96 + 8 international character sets
(Selectable by operator)
- (3) Character Font 9 x 9 dot matrix
- (4) Character Size 2.1 mm (W) x 3.1 mm (H) (0.08" x 0.12")
- (5) Paper Feed Adjustable sprocket feed/Friction feed
- (6) Paper Fanfold paper/Cut sheet
- (7) Paper Width 101.6 mm (4") – 393.7 mm (15.5")/
216 mm (8.5") – 304.8 mm (12")
- (8) Copies One original plus two carbon copies
- (9) Paper Thickness 0.3 mm (0.01") max.
- (10) Line Spacing 4.23 mm (1/6") or programmable
- (11) Columns 136, 132, 80 (Normal size)
68, 66, 40 (Enlarged size)
233, 226, 137 (Condensed size)
116, 113, 68 (Condensed-enlarged size)
- (12) Print Speed 80 CPS (Normal)
- (13) Ribbon Cartridge Ribbon (exclusive use), Black
- (14) Dimensions 592 mm (W) x 393 mm (D) x 133 mm (H)
(23.3" x 15.5" x 5.2")
- (15) MTBF 5×10^6 lines (excluding print head)
- (16) Print Head Life 100×10^6 characters

1.4.2 Parallel Interface (Standard)

- (1) Data transfer rate 1,000 CPS (min.)
- (2) Synchronization By externally supplied STROBE pulses.
- (3) Handshaking By ACKNLG or BUSY signals
- (4) Logic level Input data and all interface control signals are compatible with the TTL Level.

1.5 Major Components

The MX-100 consists, in a broad classification, of the following four major components.

(1) Model 3360 printer mechanism

This mechanism is an assembly of all the mechanical functions of the MX-100, and consists mainly of two stepper motors, a print head, a ribbon feeding mechanism, a carriage assembly, sensors and a frame section. One stepper motor functions as the print head carriage motor, while the other works as the paper feeding motor. The M-3360 has been designed extremely simple to permit easy maintenance as described later in this manual.

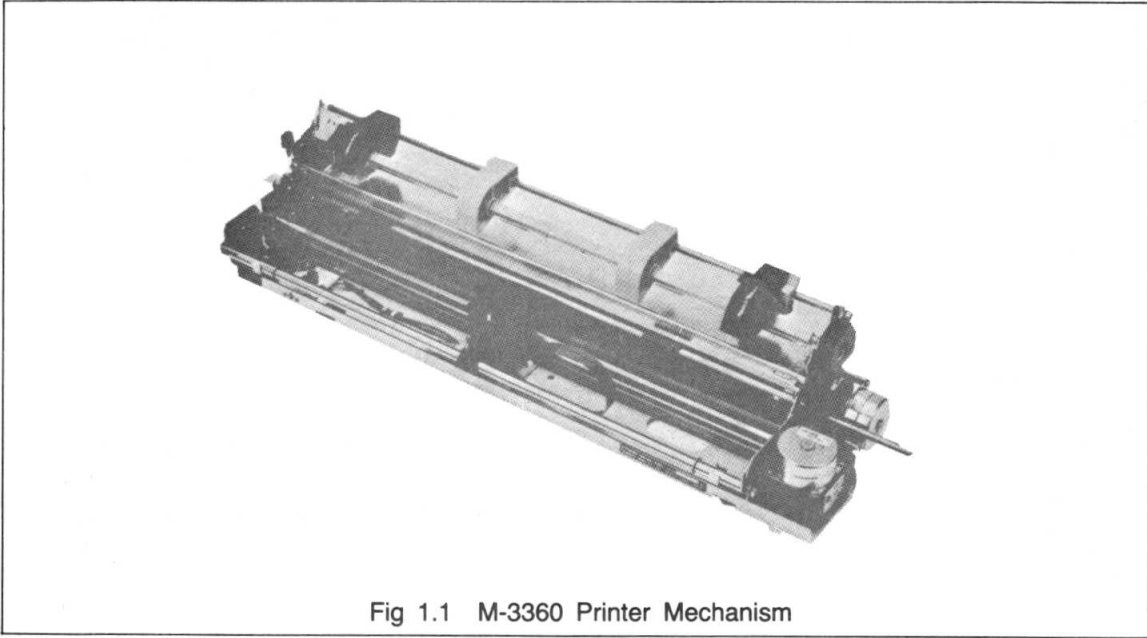

(2) Circuit boards

The MX-100 is provided with two printed circuit boards as the standard equipment. One printed circuit board functions as a main circuit board (control circuit board) with an LSI 8049 for printer control. On the main circuit board, the other printed circuit board serving as a driver circuit board is secured with two screws. The M-3360 is controlled through the 28-pin connector attached to the driver circuit board.

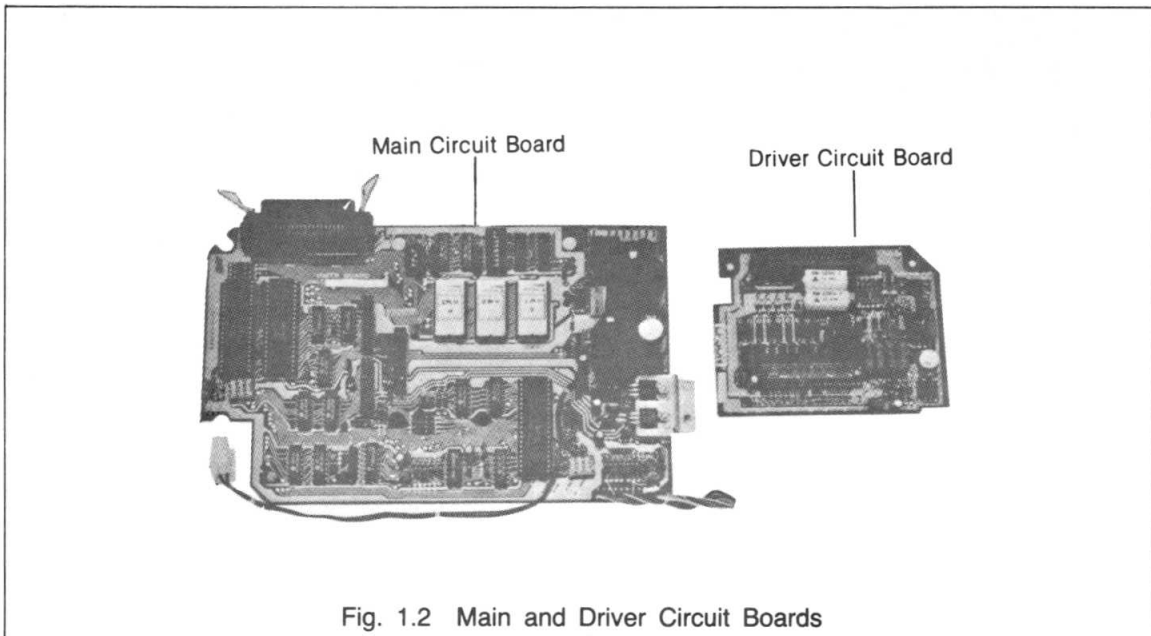

(3) Power supply circuit

The power supply circuit is partially located on the main circuit board. However, the power transformer and line filter are mounted separately on the lower case. The power supply circuit supplies all the voltages required for the MX-100. The line filter consisting of capacitors blocks noises to and from an external source.

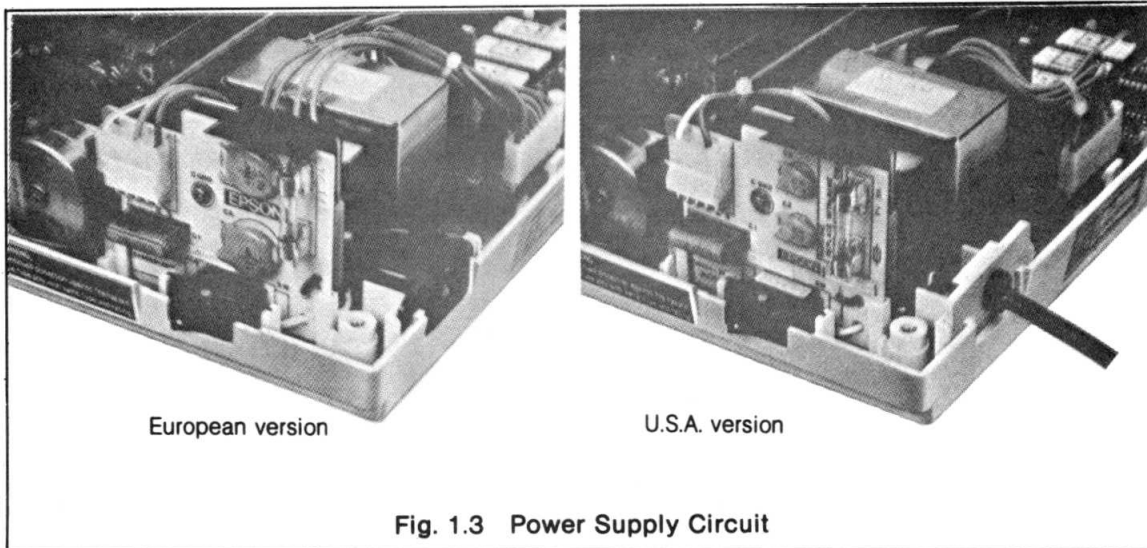

(4) Housing

The housing of the MX-100 consists of an upper case and a lower case, and accommodates all the components described in paragraphs (1), (2) and (3) above. The lower case has been designed to facilitate mounting of the abovementioned components.

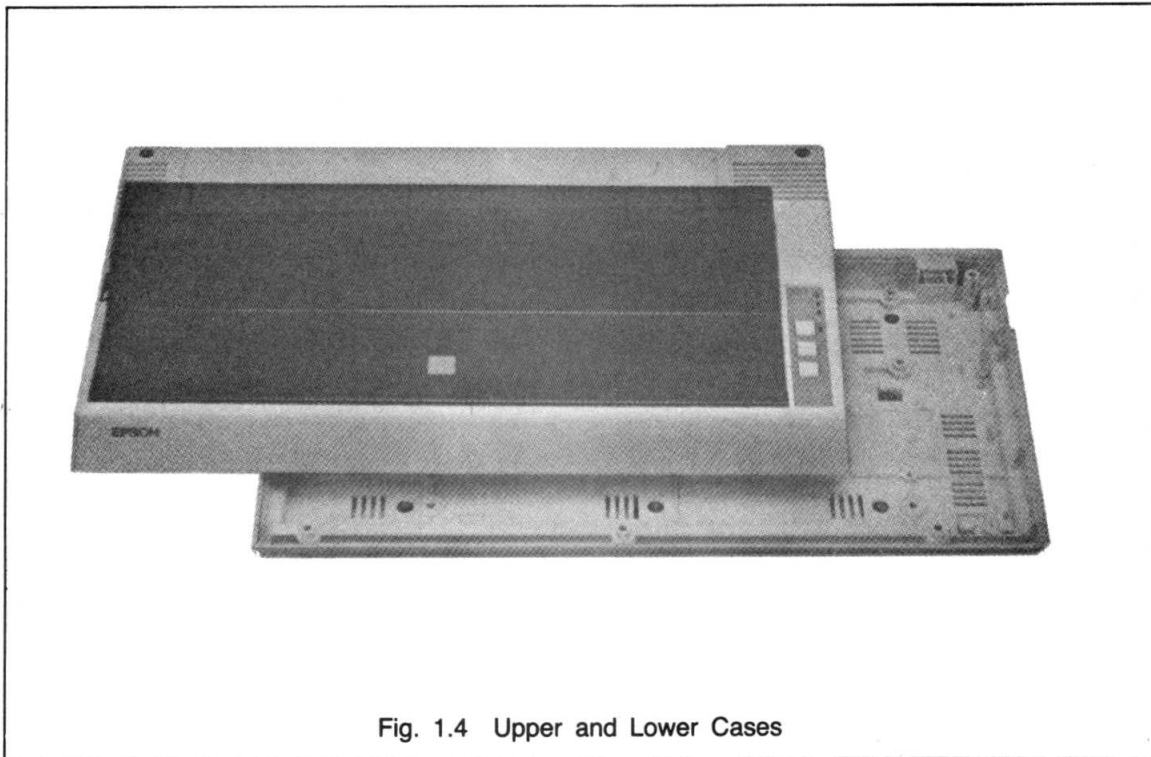

CHAPTER 2

PRINCIPLES OF OPERATION

CONTENTS

2.1 General	2-1
2.2 Block Diagrams	2-1
2.3 Principles of Operation	2-9
2.4 Electrical Circuits	2-9
2.5 Operating Principles of Printer Mechanism	2-23
2.5.1 Head carriage and paper feeding mechanisms	2-23
2.5.2 Print head	2-23
2.5.3 Ribbon feeding mechanism	2-24
2.5.4 Detecting mechanism	2-24
2.5.5 Frame section	2-24

2.1 General

This chapter provides the descriptions of signals at the various connectors electrically interconnecting such major components units as printer mechanism, driver circuit board, control circuit board and control panel of the EPSON MX-100 Dot Matrix Printer, and explains the operating principles of the various mechanisms around the electric circuits of the Printer.

2.2 Block Diagrams

The flow of signals through the respective major components of the MX-100 is shown in Fig. 2.1.

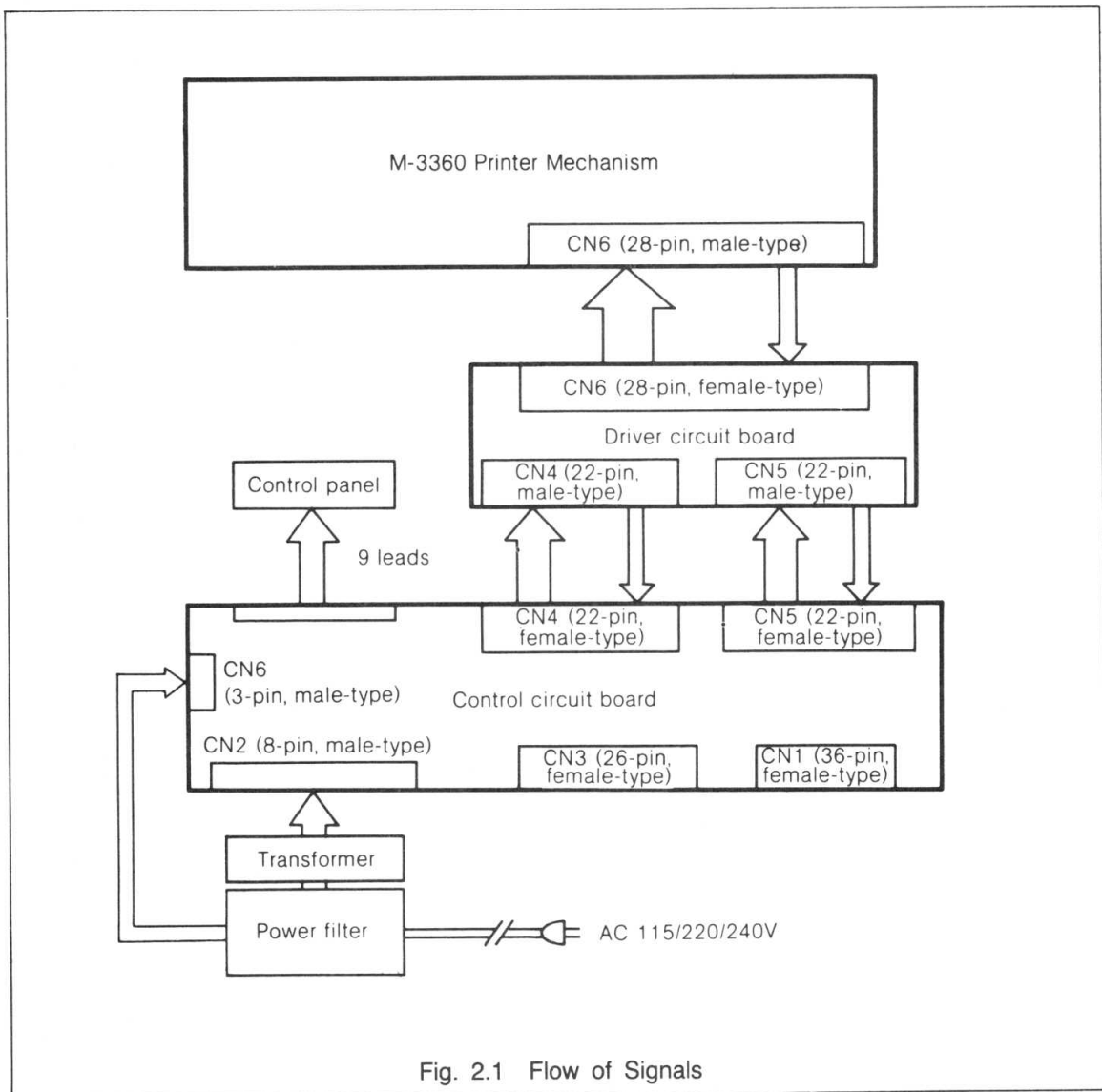

Fig. 2.1 Flow of Signals

Refer to Tables 2.1 through 2.5 for the pin assignments of respective connectors.

(1) Connector CN1

- (a) UseThis connector is used for data exchange between the MX-100 and an external computer (parallel).
- (b) Number of pins36 pins
- (c) Part number57-30360 (AMPHENOL)
- (d) Pin assignmentRefer to Table 2.1 below.

Table 2.1 Pin Assignment of CN1

Signal Pin No.	Return Pin No.	Signal	Direction	Description
1	19	STROBE	In	STROBE pulse of read data in. Pulse width must be more than 0.5 μ s at receiving terminal. The signal level is normally "HIGH"; read-in of data is performed at the "LOW" level of this signal.
2	20	DATA 1	In	These signals represent information of the 1st to 8th bits of parallel data respectively. Each signal is at "HIGH" level when data is logical "1" and "LOW" when logical "0".
3	21	DATA 2	In	
4	22	DATA 3	In	
5	23	DATA 4	In	
6	24	DATA 5	In	
7	25	DATA 6	In	
8	26	DATA 7	In	
9	27	DATA 8	In	
10	28	ACKNLG	Out	Approx. 5 μ s pulse. "LOW" indicates that data has been received and that the printer is ready to accept other data.
11	29	BUSY	Out	A "HIGH" signal indicates that the printer cannot receive data. The signal becomes "HIGH" in the following cases: 1. During data entry 2. During printing operation 3. In OFF-LINE state 4. During printer error status.
12	30	PE	Out	A "HIGH" signal indicates that the printer is out of paper.
13	—	SLCT	Out	This signal indicates that the printer is in the selected state.
14	—	AUTO FEED XT	In	With this signal being at "LOW" level, the paper is automatically fed one line after printing. (The signal level can be fixed to "LOW" with DIP SW pin 2-3 provided on the control circuit board.)
15	—	NC		Not used.
16	—	0V		Logic GND level.
17	—	CHASSIS-GND	—	Printer chassis GND. In the printer, the chassis GND and the logic GND are isolated from each other.
18	—	NC	—	Not used.
19 to 30	—	GND	—	TWISTED-PAIR RETURN signal GND level.

Table 2.1 Pin Assignment of CN1 (cont.)

Signal Pin No.	Return Pin No.	Signal	Direction	Description
31	—	$\overline{\text{INIT}}$	In	When the level of this signal becomes "LOW", the printer controller is reset to its initial state and the print buffer is cleared. This signal is normally at "HIGH" level, and its pulse width must be more than 50 μs at the receiving terminal.
32		$\overline{\text{ERROR}}$	Out	The level of this signal becomes "LOW" when the printer is in — 1. PAPER END state 2. OFF-LINE state 3. Error state
33	—	GND	—	Same as with Pin Nos. 19 to 30.
34	—	NC	—	Not used.
35				Pulled up to +5V through 3.3 k Ω resistance.
36	—	$\overline{\text{SLCT IN}}$	In	Data entry to the printer is possible only when the level of this signal is "LOW". (Internal fixing can be carried out with DIP SW pin 1-8. The condition at the time of shipment is set "LOW" for this signal.)

- NOTES: 1. "Direction" refers to the direction of signal as viewed from the printer.
 2. "Return" denotes "TWISTED PAIR RETURN" and is to be connected at signal ground level.
 As to the wiring for the interface, be sure to use a twisted-pair cable for each signal and never fail to complete connection on the Return side. To prevent noise effectively, these cables should be shielded and connected to the chassis of the host computer and the printer, respectively.
 3. All interface conditions are based on TTL level. Both the rise and fall times of each signal must be less than 0.2 μs .
 4. Data transfer must not be carried out by ignoring the $\overline{\text{ACKNLG}}$ or BUSY signal.
 (Data transfer to this printer can be carried out only after confirming the $\overline{\text{ACKNLG}}$ signal or when the level of the BUSY signal is "LOW".)

(2) Connector CN2

(a) UseThis connector is used to supply the required AC voltages to the control circuit board.

(b) Number of pins8 pins

(c) Pin assignmentRefer to Table 2.2 below.

Table 2.2 Pin Assignment of CN2

Pin No.	Signal Name	Color of Lead	Purpose
1	+12V AC	Gray	For optional interfaces
2	+12V AC	Gray	
3	+25V AC	Orange	For stepper motor
4	+25V AC	Orange	
5	+ 9V AC	Red	For logic circuitry
6	+ 9V AC	Red	
7	+10V AC	Blue	For stepper motor
8	+10V AC	Blue	

(3) Connector CN3

- (a) Use This connector is used when connecting an optional P.C. board to the MX-100.
- (b) Number of pins26 pins
- (c) Pin assignmentRefer to Table 2.3 below.

Table 2.3 Pin Assignment of CN3

Connector Pin No.	Signal Name	Description of Signal	Direction
1	$\overline{\text{ERR}}$	Error	Out
2	PE	Paper End	Out
3	D7	Data Bit 7	In
4	$\overline{\text{RDY}}$ (BUSY)	Ready	Out
5	D6	Data Bit 6	In
6	$\overline{\text{ACK}}$	Acknowledge	Out
7	D5/PAR DIS	Data Bit 5/Parity Disable	In
8	$\overline{\text{INIT}}$	Initial	In
9	D4/O/E	Data Bit 4/Odd Parity Select/Even Parity Select	In
10	$\overline{\text{STB}}$	Strobe	In
11	D8/SI	Data Bit 8/Serial Signal Input	In
12	+12	+12V AC	Out
13	$\overline{\text{R}}$	Reset	Out
14	+12	+12V AC	Out
15	D3/B2	Data Bit 3/Bit Rate Select	In
16	+5	+5V DC	Out
17	D2/B1	Data Bit 2/Bit Rate Select	In
18	+24	+24V DC	Out
19	D1/8/7	Data Bit 1/8 Bit Select/7Bit Select	In
20	+12	+12V DC	Out
21	P/S	Parallel Select/Serial Select	In
22	—	—	—
23	$\overline{\text{SELIN}}$	Select In	In
24	GL	Ground	—
25	$\overline{\text{PET TRS}}$	PET/TRS Select	In
26	GL	Ground	—

NOTE: "Direction" refers to the direction of signal flow as viewed from the control circuit board.

(4) Connectors CN4

- (a) UseTwo CN4 connectors (one with male contacts and the other with female contacts) are used to supply control signals between the control circuit board and driver circuit board of the MX-100.
- (b) Number of pins22 pins
- (c) Pin assignmentRefer to Table 2.4 below.

Table 2.4 Pin Assignment of CN4

Connector Pin No.	Signal Name	Description of Signal	Direction
1	GP	Ground Level	—
2	GP	Ground Level	—
3	—	—	—
4	—	—	—
5	GP	Ground Level	—
6	GP	Ground Level	—
7	H8	Head Solenoid Drive Signal	Out
8	H7	Head Solenoid Drive Signal	Out
9	H6	Head Solenoid Drive Signal	Out
10	H5	Head Solenoid Drive Signal	Out
11	H4	Head Solenoid Drive Signal	Out
12	H3	Head Solenoid Drive Signal	Out
13	H2	Head Solenoid Drive Signal	Out
14	H1	Head Solenoid Drive Signal	Out
15	H9	Head Solenoid Drive Signal	Out
16	(555Q)	Print Head Drive Pulse	In
17	\overline{R}	Reset	In
18	\overline{PE}	Paper End	In
19	CRB	Phase B for Carriage Stepper Motor Drive	Out
20	$\overline{(132\text{ Columns})}$	Carriage Stepper Motor Control (+14V)	Out
21	(FP)	Print Head Drive Pulse	Out
22	CRA	Phase A for Carriage Stepper Motor Drive	Out

NOTE: "Direction" refers to the direction of signal flow as viewed from the control circuit board.

(5) Connectors CN5

- (a) UseTwo CN5 connectors (one with male contacts and the other with female contacts) are used to supply control signals between the control circuit board and driver circuit board of the MX-100.
- (b) Number of pins22 pins
- (c) Pin assignmentRefer to Table 2.5 below.

Table 2.5 Pin Assignment of CN5

Connector Pin No.	Signal Name	Description of Signal	Direction
1	CRD	Phase D for Carriage Stepper Motor Drive	In
2	LFB	Phase B for Paper Feed Stepper Motor Drive	In
3	$\overline{\text{SLF}}$	Line Feed Activate	In
4	CRC	Phase C for Carriage Stepper Motor Drive	In
5	$\overline{(80 \text{ columns})}$	Carriage Stepper Motor Control (+24V)	Out
6	LFC	Phase C for Paper Feed Stepper Motor Drive	In
7	Head Trigger	Timer Triggering Signal	In
8	LFA	Phase A for Paper Feed Stepper Motor Drive	In
9	$\overline{\text{RS}}$	Home Position Signal	Out
10	LFD	Phase D for Paper Feed Stepper Motor Drive	In
11	$\overline{\text{PTS}}$	Clock Input	Out
12	GL	Ground	—
13	GL	Ground	—
14	+24	+24V DC	In
15	+24	+24V DC	In
16	+24	+24V DC	In
17	+24	+24V DC	In
18	+5	+5V DC	In
19	—	—	—
20	—	—	—
21	Vx	Power Failure Detection Signal	In
22	+14	+14V DC	In

NOTE: "Direction" refers to the direction of signal flow as viewed from the driver circuit board.

(6) Connectors CN6

(a) Use Two CN6 connectors (one with male contacts and the other with female contacts) are used to supply control signals between the M-3360 printer mechanism and the driver circuit board of the MX-100.

(b) Number of pins 28 pins

(c) Pin assignment Refer to Table 2.6 below.

Table 2.6 Pin Assignment of CN6

Connector Pin No.	Signal Name	Description of Signal	Direction
1	H1	Head Driving Signal	In
2	H2	Head Driving Signal	In
3	H3	Head Driving Signal	In
4	H4	Head Driving Signal	In
5	H5	Head Driving Signal	In
6	H6	Head Driving Signal	In
7	H7	Head Driving Signal	In
8	H8	Head Driving Signal	In
9	H9	Head Driving Signal	In
10	SOL	Solenoid common line +24V	In
11	SOL	Solenoid common line +24V	In
12	V+5	+5V	In
13	SCR	Carriage Stepper Motor Current Limiting Signal	In
14	SLF	Paper Feed Stepper Motor Current Limiting Signal	In
15	GLED	Ground level	—
16	GPE	Ground level	—
17	GR	Ground level	—
18	\overline{PE}	Paper End Signal from Printer Mechanism	Out
19	\overline{PTS}	Timing Signal from Printer Mechanism	Out
20	\overline{RS}	Reset Signal from Printer Mechanism	Out
21	CRA	Carriage Drive Signal	In
22	CRB	Carriage Drive Signal	In
23	CRC	Carriage Drive Signal	In
24	CRD	Carriage Drive Signal	In
25	LFA	Paper Feed Drive Signal	In
26	LFB	Paper Feed Drive Signal	In
27	LFC	Paper Feed Drive Signal	In
28	LFD	Paper Feed Drive Signal	In

NOTE: "Direction" refers to the direction of signal flow as viewed from the Printer Mechanism.

2.3 Principles of Operation

The M-3360 Printer Mechanism generates a timing signal (\overline{PTS}) which determines the position of the print head and a reset signal (\overline{RS}) which determines the left margin position of the Printer. In addition, a signal (PE) which judges the presence or absence of paper in the Printer is output to the Printer. These three signals govern the operation of the Printer. The driver control board sends to the Printer, print head solenoid drive signals, carriage stepper motor drive signals, paper feed stepper motor drive signals and current limiting signals which minimize the heat generation by the respective stepper motors. All these signals are controlled by the one-chip microprocessors 8049 and 8041 located on the control circuit board. The printer mechanism executes each operation according to the signal from the driver circuit board which serves as a controller. These electric circuits and mechanical operations are detailed in the following sections 2.4 and 2.5.

2.4 Electric Circuits

(1) Fuse and filter circuit

The fuse and filter circuit is located on a Bakelite circuit board, together with the power switch which turns on and off the primary AC input voltage. Fig. 2.2 shows the layout of the respective components on the fuse and filter circuit, and Fig. 2.3, the connection diagram of this circuit.

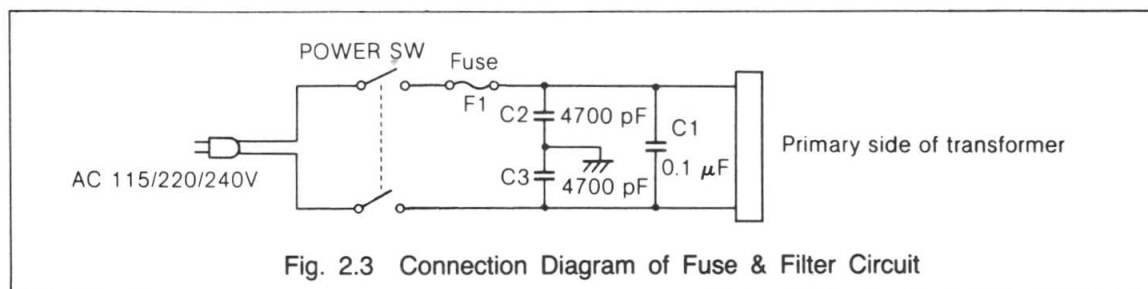
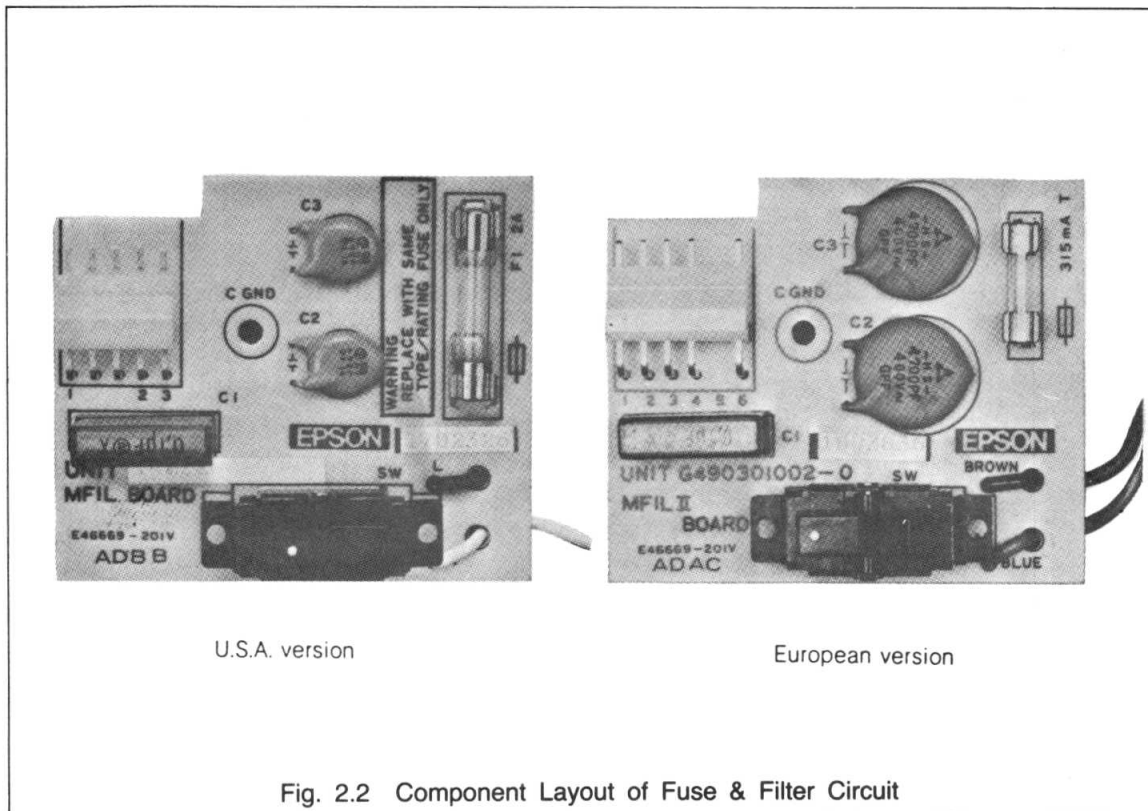

The AC 115, 220 or 240V from the power line first flows through fuse F1 (2A for 115V, 315 mA for 220/240V) and enters the double-throw power switch. Between this line and ground, three noise suppressing capacitors C1, C2 and C3 are connected. The capacitors function to filter the line noise from the power source as well as the noise from the printer to the power line, so that the digital circuits within Printer are not affected by external noise and any noise from the Printer does not leak out to external lines.

(2) Power supply circuit

In this circuit, the AC 115, 220 or 240V from the primary side is lowered by the power transformer to produce voltages required for the control circuit board, driver circuit board and optional circuit board, respectively. Fig. 2.4 shows the windings and input/output voltages of the power transformer.

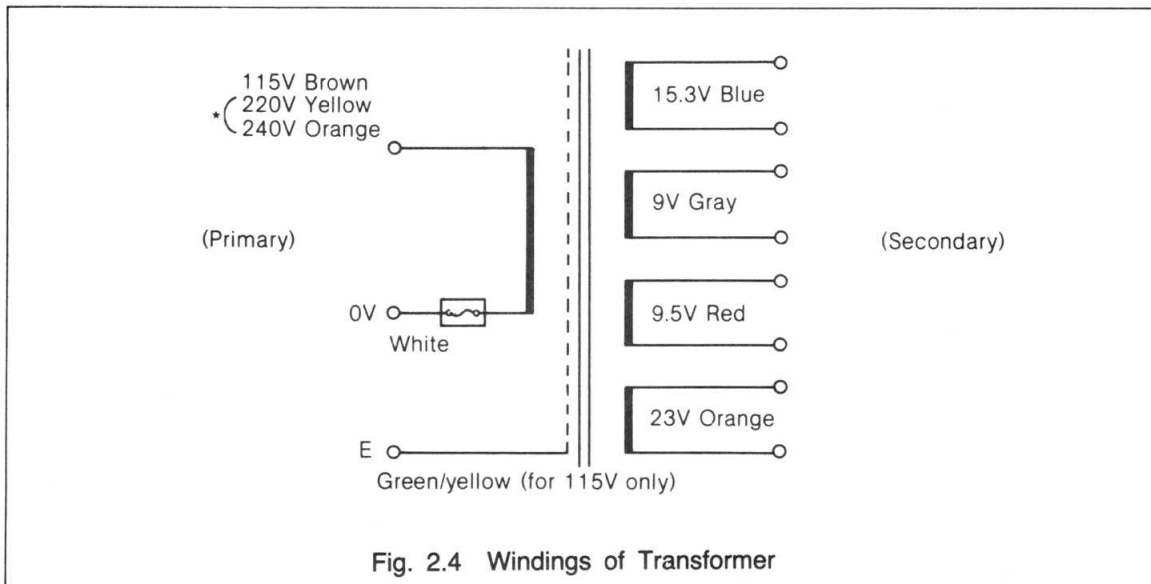

Fig. 2.4 Windings of Transformer

NOTE: The fourth pin (marked with "2") of the 5-pin connector on the primary side is used for selection of 220/240V. For 220V, insert the yellow wire into the fourth pin and the orange wire (240V) not used into the fifth pin (marked with "3").

The voltages lowered by the power transformer are converted into required voltages by the rectifier and constant-voltage circuit. Fig. 2.5 shows the connection diagram of the rectifier and constant-voltage circuit.

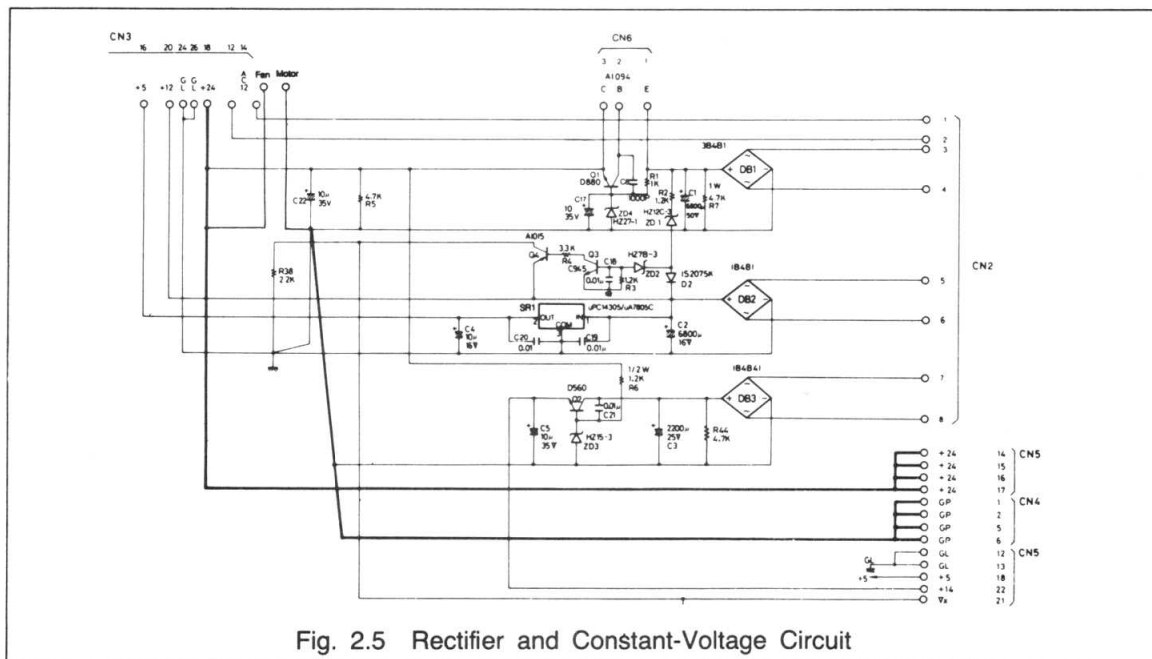

Fig. 2.5 Rectifier and Constant-Voltage Circuit

In this circuit, the following voltages are produced.

- +24V DCPower supply for driving print head solenoid and stepper motors
- + 5V DCPower supply for TTL logic
- +12V DCPower supply for buzzer, LED's, etc.
- +14V DCFor stepper motor holding current
- +12V ACPower supply for serial interface (option)

Should the supply voltage become abnormal, this circuit detects such condition and causes a reset signal to be generated in the control circuit so as to return the control circuit to its original state, and at the same time, inhibits voltage from being applied to the print head solenoid driving transistors, thus assuring proper energization of the print head solenoid.

In this circuit, the voltage level at the zener diode ZD1 connected to the rectified output of the +24V line is normally 12V and the voltage level at the zener diode ZD2 connected to the base of transistor Q3 is normally 7V. When a total of these two voltages exceeds 19V, a current is supplied to the base of transistor Q3, causing transistor Q4 to turn on to permit the supply of +12V to the head driver circuit. Should the voltage of the 24V line reduce to below 19V for some reason or other, transistor Q4 is caused to turn off, thus prohibiting the supply of +12V to the base of the head driver transistor. The print head solenoid is thus inactivated to prevent the dot wires of the print head from being damaged.

+24V is produced from the 23V supplied from the power transformer into a current of 1.5A on the average at 24V by a series regulator consisting mainly of zener diode ZD4 and transistor Q4, after being processed through a bridge rectifier. The +5V supplied to the logic circuit is obtained by producing a current of approx. 1.5A with three-terminal regulator SR1.

(3) 8155

Data and signal exchange with an external computer (e.g., standard parallel computer) is performed by LSI "8155" which incorporates MCS85 series I/O's and a 256-byte RAM. The 8155 is operated in the ALT3 mode according to the command from the main microprocessor of LSI "8049". In this case, port PC2 is used as the input port for the strobe pulse (\overline{STB}), and ports PA0 – PA7 as the input ports for all data.

Accordingly, when one of the data is taken in by the \overline{STROBE} signal, Ready (\overline{RDY}) signal is immediately output to port PC1. The strobe pulse of the data is latched by the 8155 at the trailing edge of the pulse. The ports PB0 – PB7 and PC4 of the 8155 are used to output the respective drive signals for the 9 print head solenoids.

The 256-byte memory (RAM) in the 8155 is used as the storage area for data.

Data exchange with the main microprocessor of the 8049 is performed through address data bus lines AD0 – AD7. Fig. 2.6 shows the flow of data and signals through the 8155 and Fig. 2.7, the 8155 and its peripheral circuits. The ports PA0 – PA7 of the 8155 are respectively connected to the optional interface connector for system expansion, to permit communication between the MX-100 and any optional device when attached to the Printer.

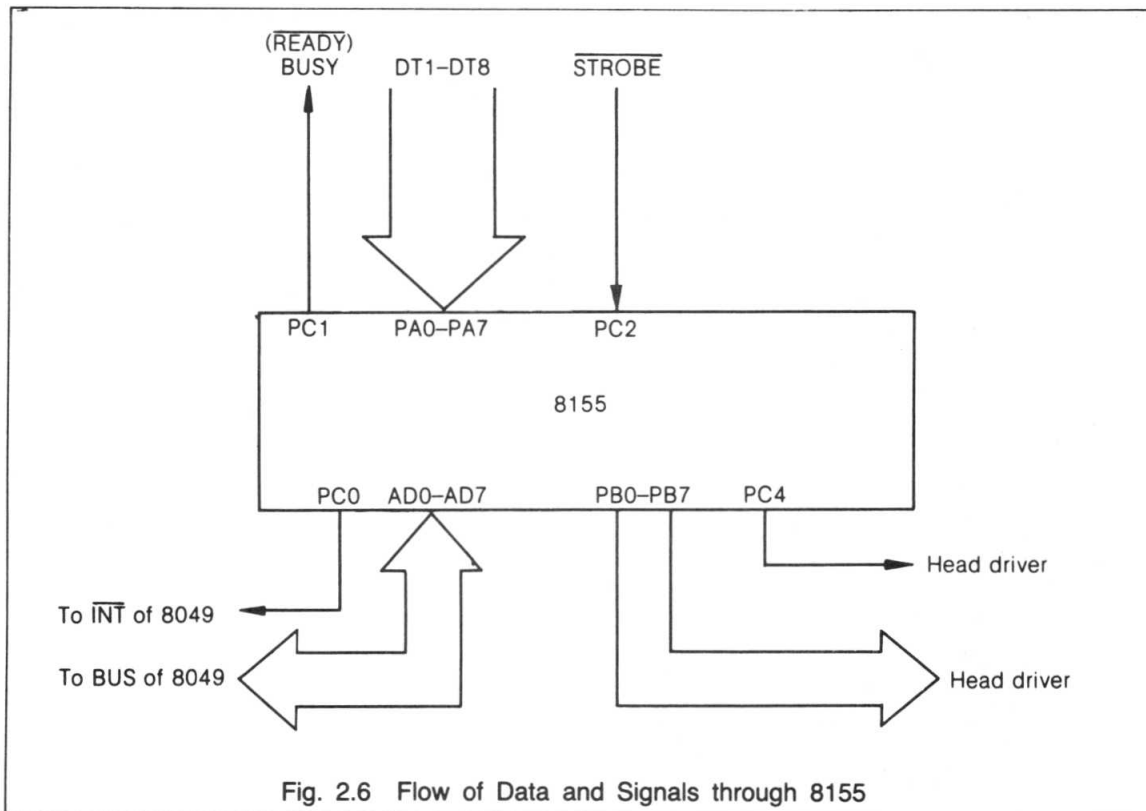

Fig. 2.6 Flow of Data and Signals through 8155

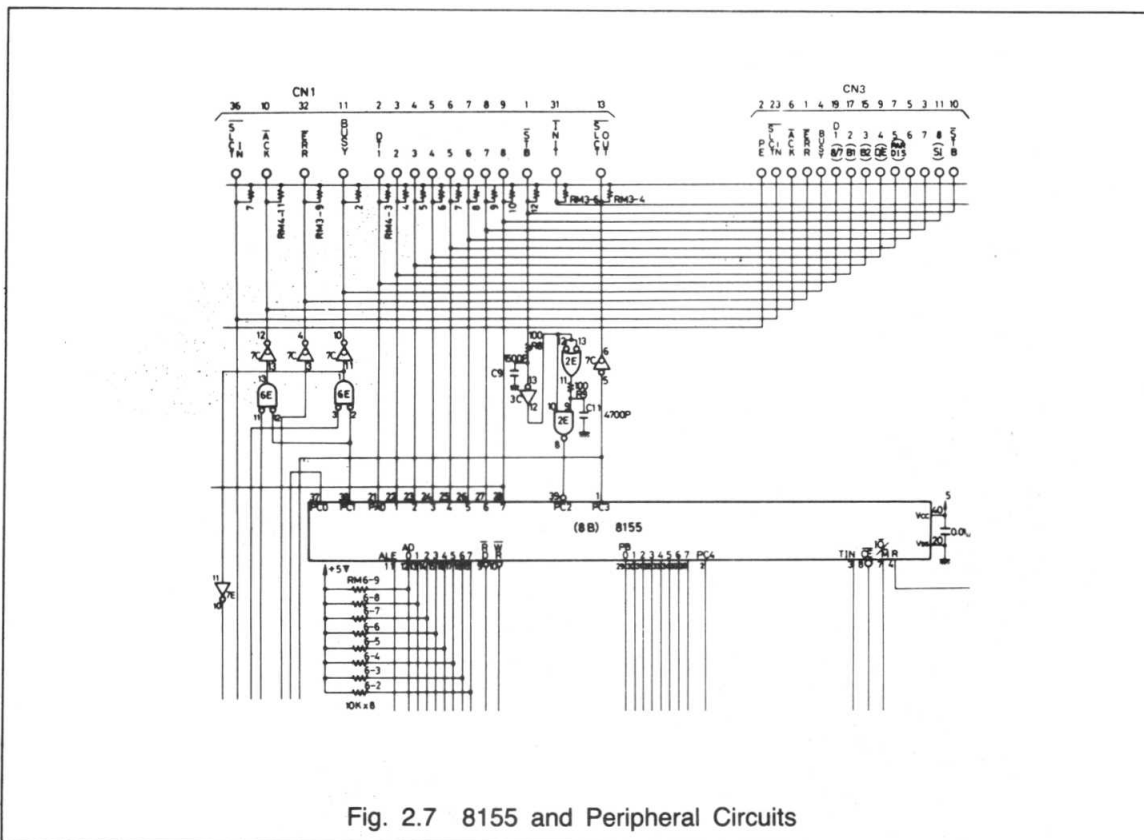

Fig. 2.7 8155 and Peripheral Circuits

The data transfer sequence of $\overline{\text{STROBE}}$ and $\overline{\text{READY}}$ signals is shown in Fig. 2.8.

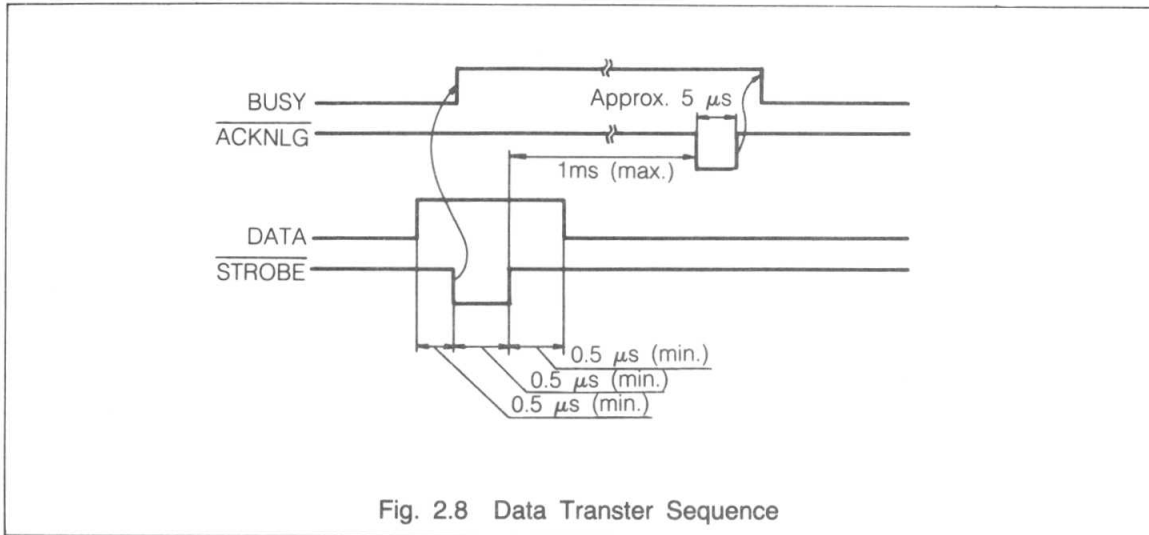

Fig. 2.8 Data Transfer Sequence

(4) 8041

The LSI 8041 called "slave CPU," performs operation controls of the printer mechanism M-3360 with 1-k byte program. It sends signals to control two stepper motors, i.e., print head carriage stepper motor and paper feed stepper motor, and to inform the master CPU 8049 of the status of the printer. The two stepper motors are driven by two 2-phase excitation signals, phase sequences of which are shown in Fig. 2.9 and Fig. 2.10.

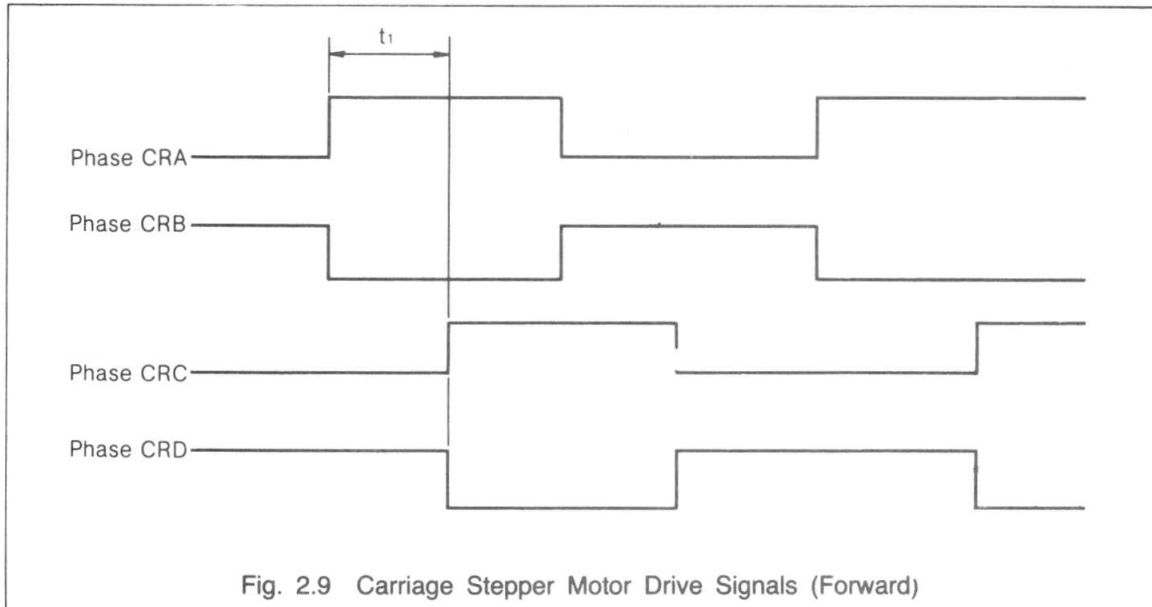

Fig. 2.9 Carriage Stepper Motor Drive Signals (Forward)

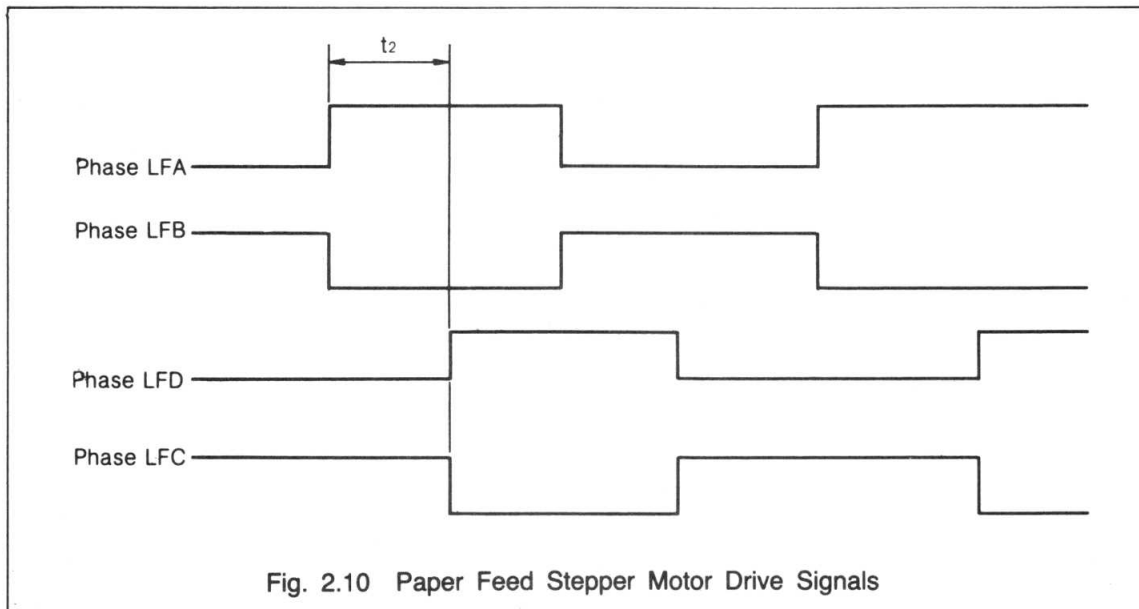

Fig. 2.10 Paper Feed Stepper Motor Drive Signals

As shown in Figs. 2.9 and 2.10, the respective stepper motors are driven by two two-phase excitation signals. However, the driving pulse width t_1 of the carriage stepper motor differs depending on the type of character to be printed, as shown below.

(a) t_1 of carriage stepper motor

- 1) Approx. 2.08 msec (with normal and enlarged characters)
- 2) Approx. 4.16 msec (with condensed characters)

(b) t_2 of paper feed stepper motor: Approx. 4.16 msec

The 8041 not only generates drive signals (A phase to D phase) for the two stepper motors, but also controls the voltages to be applied to the respective motors. When the motors are not running, +14V DC is supplied to them through 120 Ω resistor. When the motors run, the 8041 controls the supply voltage +24V DC for both the motors and the +14V DC for the carriage stepper motor to secure the required current to drive.

Ports P20 to P23 in the 8041 are used to send the status signals of the printer to the CPU 8049. P20 ($\overline{\text{PRAV}}$) is sent out after the carriage has finished acceleration and informs the CPU 8049 of the start of print data transfer. P21 ($\overline{\text{DIRAV}}$) is sent out whenever the printing operation is finished and is used by the CPU 8049 to decide the next printing direction. P22 (DIR) represents a signal indicating the moving direction of the carriage. If it is High, the carriage will move from left to right. If it is Low, the carriage will move from right to left. P23 (ERR) signals the CPU 8049 that there is a malfunction in the carriage stepper motor or the LSI 8041.

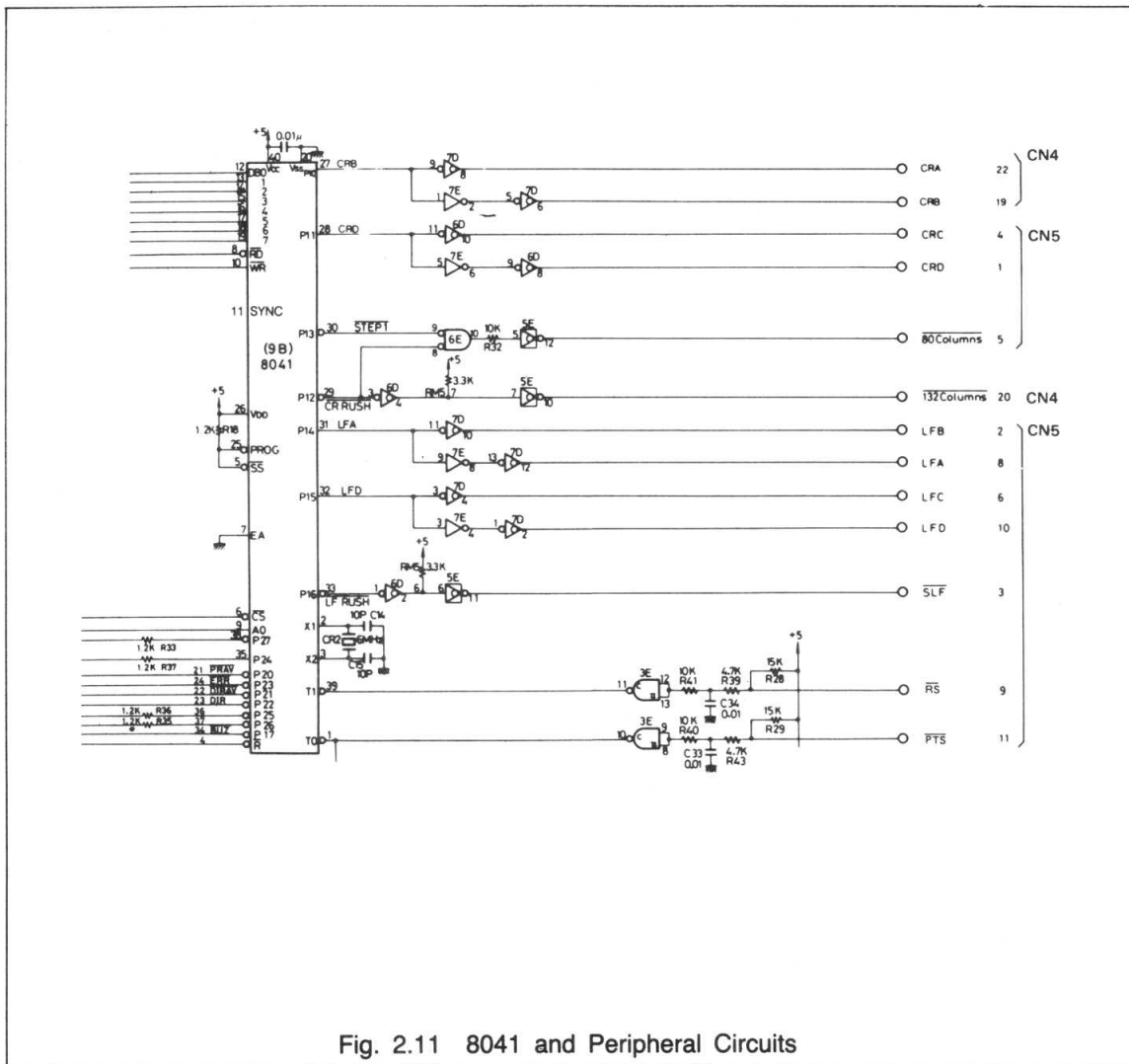

Fig. 2.11 8041 and Peripheral Circuits

(5) 8049

The LSI 8049 functions as the main controller of the MX-100 and executes all instructions according to the program stored in ROM(s).

1. The ROM size is a total of 6k bytes. The following three combinations of CPU and ROM(s) are available.

- (a) 8049 (2-k M-ROM) + 2332 (4-k M-ROM) (1B)
- (b) 8039 (2-k M-ROM) + 2716 (1B) + 2716 (2B)
- (c) 8049 (2-k UM-ROM) + 2716 (1B) + 2716 (2B) + 2716 (3B)

NOTES: 1. 1B, 2B and 3B represent the socket numbers indicated on the PCB.

2. 2716 is a 2-k PROM.

3. ROM types may vary depending on the user's specifications. Care must be taken with respect to the compatibility of ROMs.

2. Data stored in the external ROM (2716 or 2332) are fetched and decoded in the CPU 8049 in the following sequence.

1) Address

- a) High address bit is specified by ports P20 through P24 on the CPU 8049.
- b) Low address bit is specified by latching the address data onto the 74LS175 with ALE signal.

2) Read out data

Data is read out by $\overline{\text{PSEN}}$ signal and taken into the CPU 8049.

(6) 74LS367

The 74LS367 is assigned to the external memory address space (D00H-EFFH) of the 8049.

Since varied requirements may exist among the users of the MX-100 and modifications to the functional specifications of the MX-100 may be called for by the users to satisfy such requirements, two DIP switches are provided in this memory space on the control circuit board. The DIP switches consisting of an 8-pin switch (SW1) and a 4-pin switch (SW2) permit changes to the functions of the MX-100 according to the user's requirements, and the status of each DIP switch can be read under the software control of the 8049. Fig. 2.14 shows the locations of the DIP switches and Fig. 2.15, the DIP switch status read circuit. (Refer to the Operation Manual of the MX-100 for the functions of the respective DIP switches.)

The status of DIP SW1 can be read out through the LS367 onto the address/data bus line, whereas the status of DIP SW2 can be read out through the slave CPU 8041.

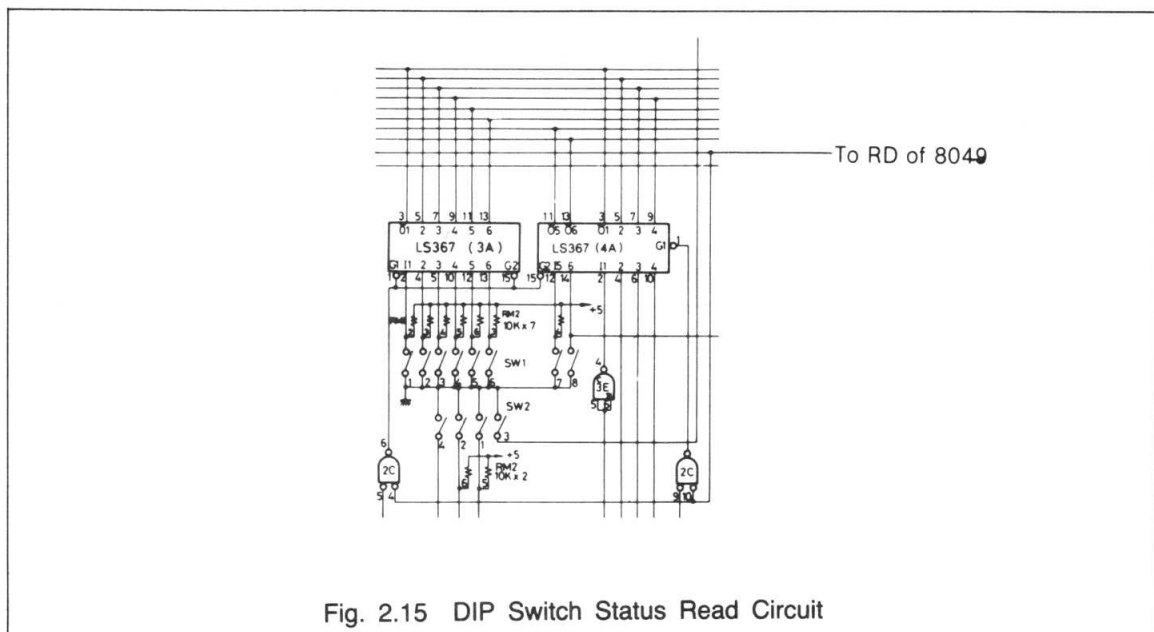
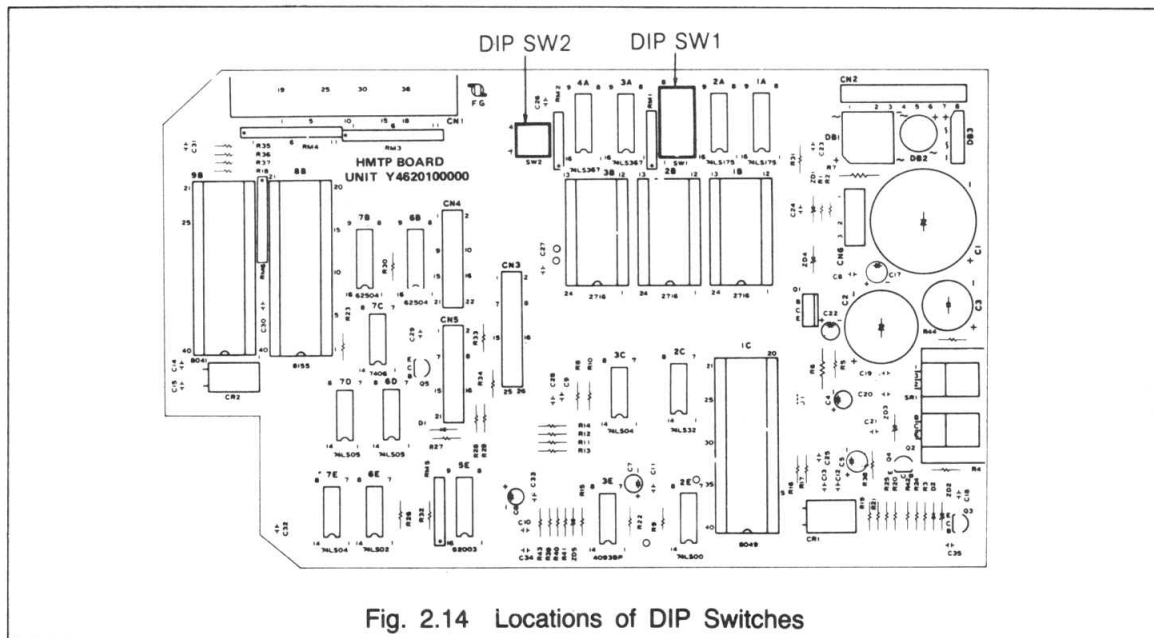

(7) Reset and timing sensor circuits

The reset (HP sensor) circuit is provided to detect the left end home position of the print head when the power switch is turned on or signal INIT is applied to the Printer. The detection of this position is performed by a photocoupler utilizing photoelectric conversion. Fig. 2.16 shows the reset circuit.

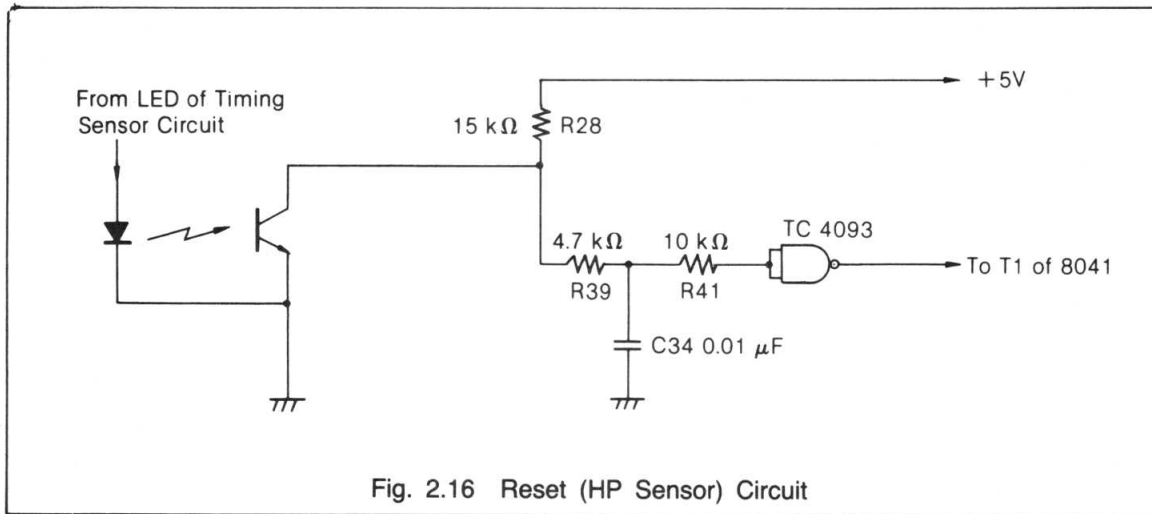

The output signal from the phototransistor used as the photocoupler is integrated and input to the Schmitt circuit which prevents the waveform of the output signal from being disturbed due to noise or mechanical vibrations.

The timing (PTS) sensor circuit functions to confirm the position of the print head driven by the carriage stepper motor. Fig. 2.17 shows the timing sensor circuit which is exactly the same as the reset circuit in the principle of operation.

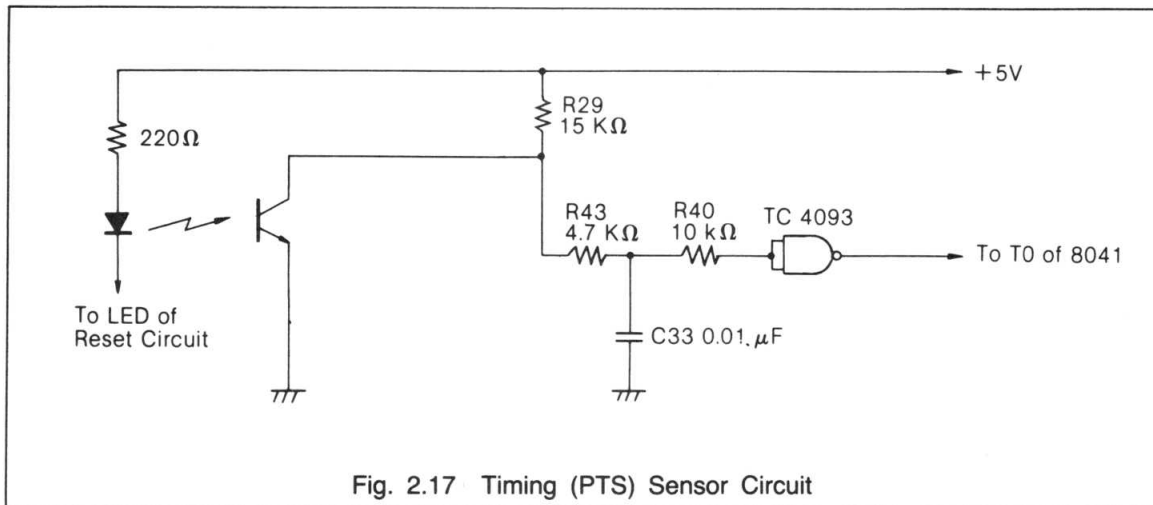
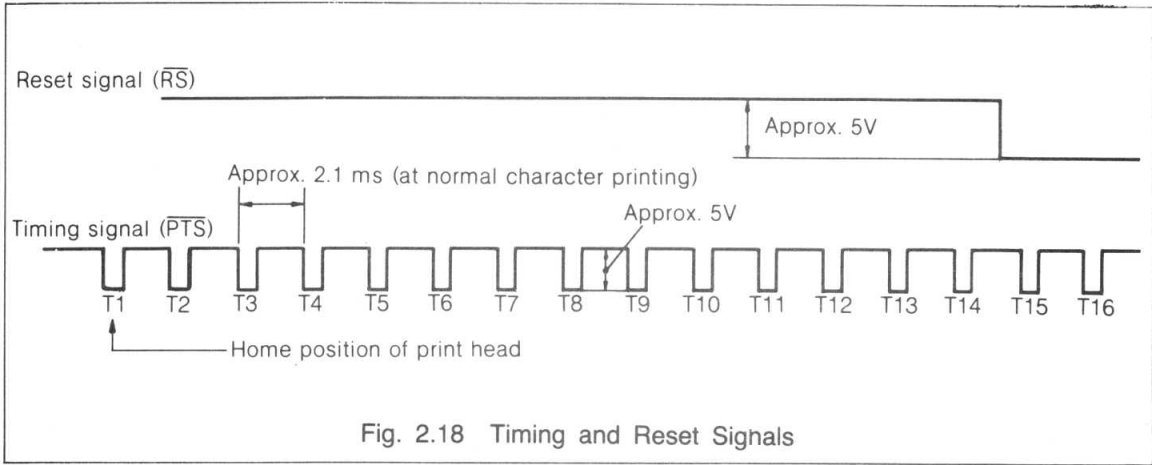
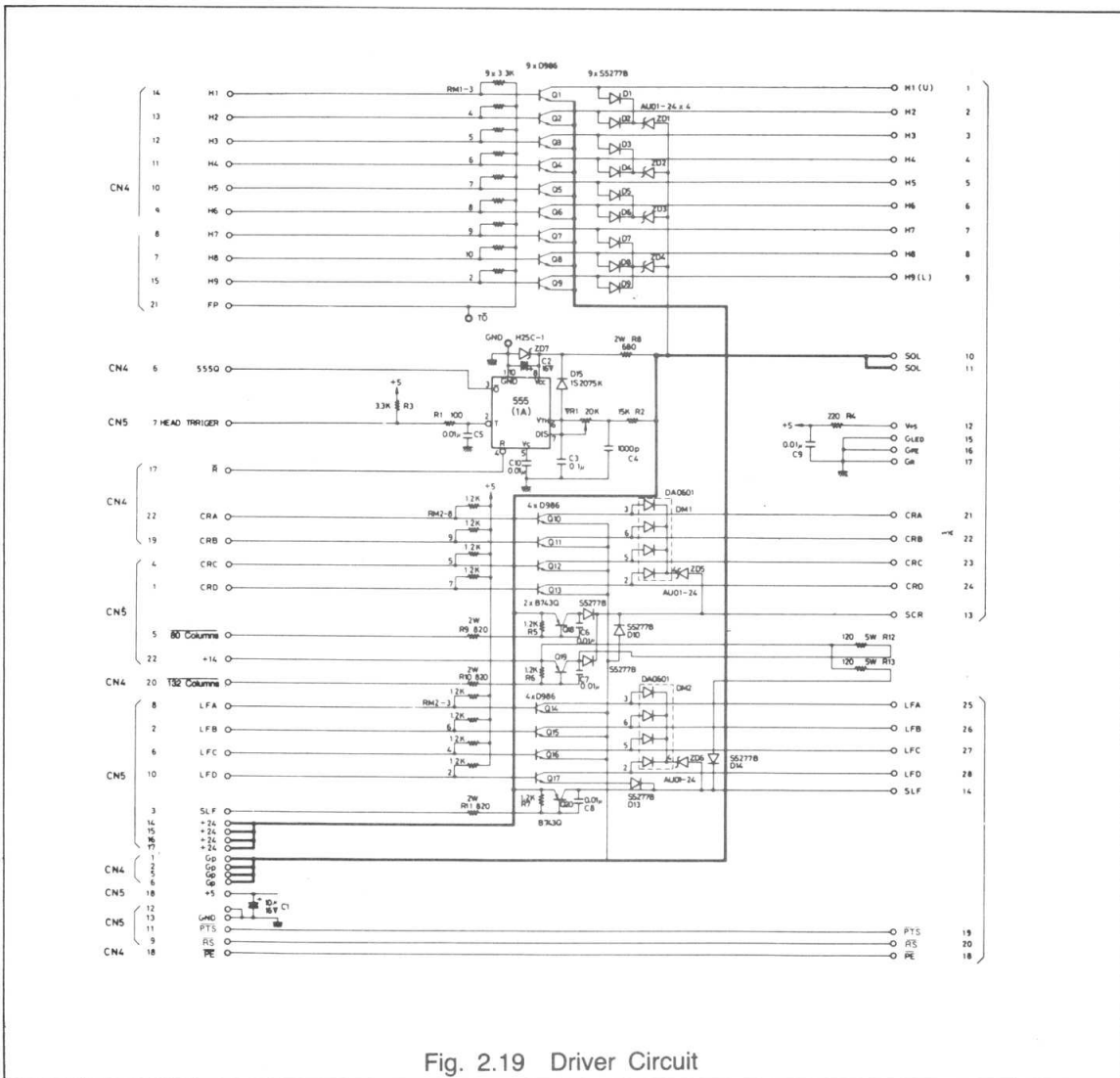

Fig. 2.18 shows the phase relationship between the timing signal (\overline{PTS}) and the reset signal (\overline{RS}).



(8) Driver circuit

The driver circuit amplifies very small signals for the carriage and paper feed stepper motors to supply the currents necessary for driving the stepper motors, and also determines the pulse duration for energizing the print head solenoid. Fig. 2.19 shows the driver circuit.



(a) Head driver

The head driver mainly consists of 9 transistors (2SD986). The current waveform of the print head is shown in Fig. 2.20.

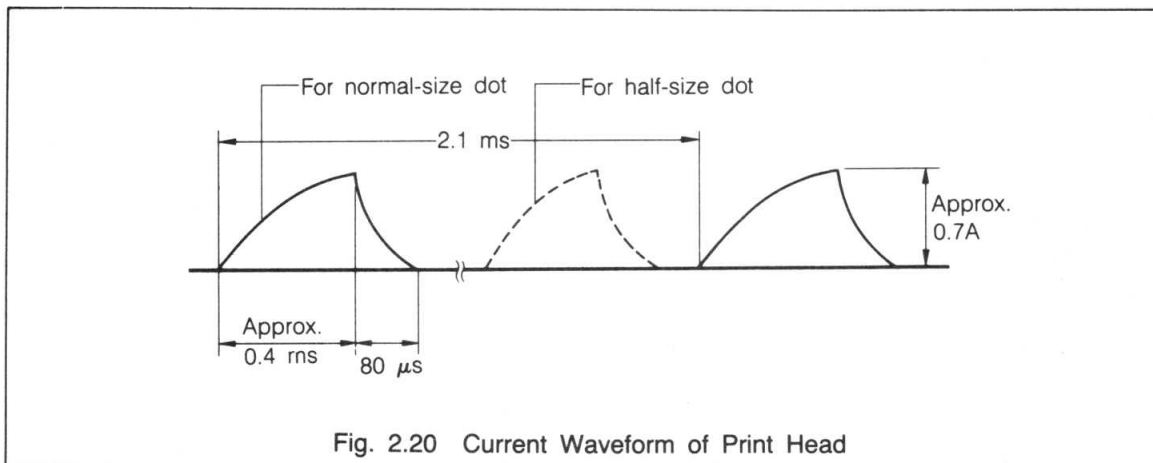

Fig. 2.20 Current Waveform of Print Head

Since a load to be connected to the collector of each transistor (2SD986) is a component of inductance, the transistor is regulated by a zener diode so that a collector breakdown voltage will not occur due to the counterelectromotive force generated at the time of switching off the transistor. The driver circuit also incorporates an IC timer to obtain a head driving pulse width corresponding to the voltage fluctuation, so that a constant output energy is always maintained at the print head solenoid according to the change in the voltage applied to the print head. Fig. 2.21 illustrates the relationship between the voltage applied to the print head and head driving pulse width.

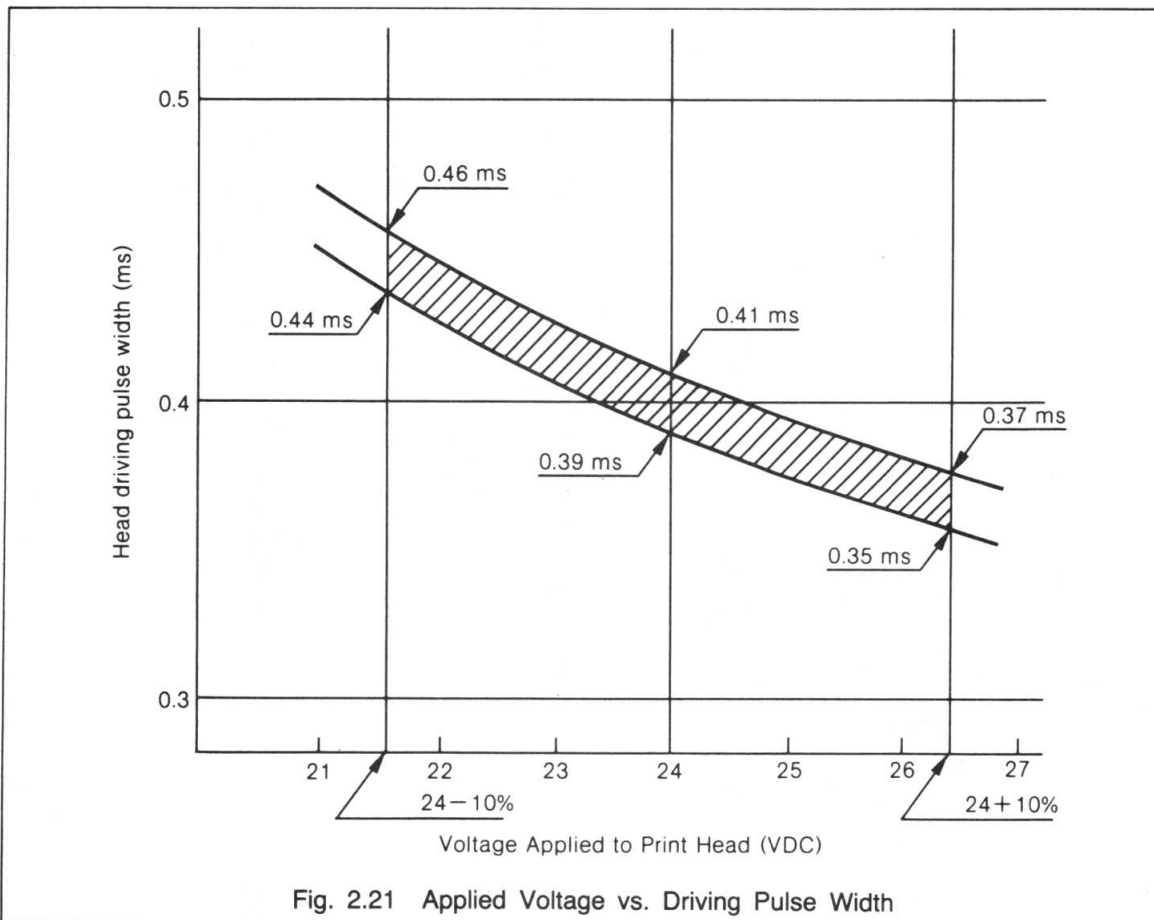

Fig. 2.21 Applied Voltage vs. Driving Pulse Width

The Printer has been adjusted so that the head driving pulse width becomes 0.4 msec when +24V DC is applied to the print head.

(b) Stepper motor driver

The stepper motor driver functions to amplify two two-phase excitation signals and control the voltages to be applied to the respective stepper motors as follows.

	Carriage stepper motor		Paper feed stepper motor	
	Voltage	Circuit	Voltage	Circuit
When not operating	+14V	via R12	+14V	via R13
When operating normally	+24V	via Q18	+24V	via Q20
When operating at low speed	+14V	via Q19	—	—

Both the carriage and paper feed stepper motors require a mean current of approx. 0.3A when they are driven by two two-phase excitation signals. The carriage stepper motor operates at approx. 500 pulse per second when the Printer performs normal character printing at 136 columns.

(9) Switches and indicators on control panel

The MX-100 has three switches and four indicators on its control panel. All the four indicators are green LED's, while the three switches are of non-lock type. Refer to the MX-100 Operation Manual for detailed information on the functions of the respective switches and indicators. The switches and indicators on the control panel are connected to the ports of the LSI 8041 or 8049 and their operations are under the software control of the LSI. Fig. 2.22 shows the locations of the switches and indicators on the control panel, and Table 2.7 shows the 9 signal lines extending from the control circuit board to the control panel.

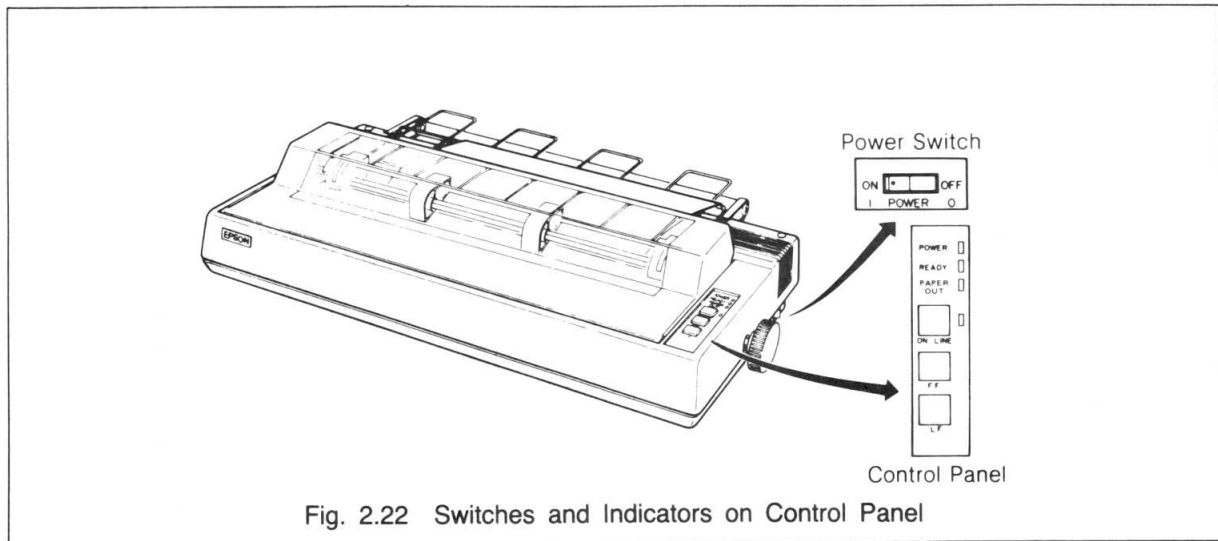

Fig. 2.22 Switches and Indicators on Control Panel

Table 2.7 Signal Lines from Control Circuit to Control Panel

Connector Pin No.	Signal Name	Description of Signal	Color of Lead
1	ON LINE LP	Signal for illuminating ON LINE indicator	Purple
2	PE LP	Signal for illuminating PAPER OUT indicator	White
3	READY LP	Signal for illuminating READY indicator	Gray
4	ON/OFF LINE SW	ON LINE switch	Yellow
5	FF SW	FORM FEED switch	Orange
6	LF SW	LINE FEED switch	Blue
7	GL	Ground	Black
8	+12	+12V DC	Brown
9	BUZZER	Buzzer	Red

Fig. 2.23 shows the switch and indicator control circuit.

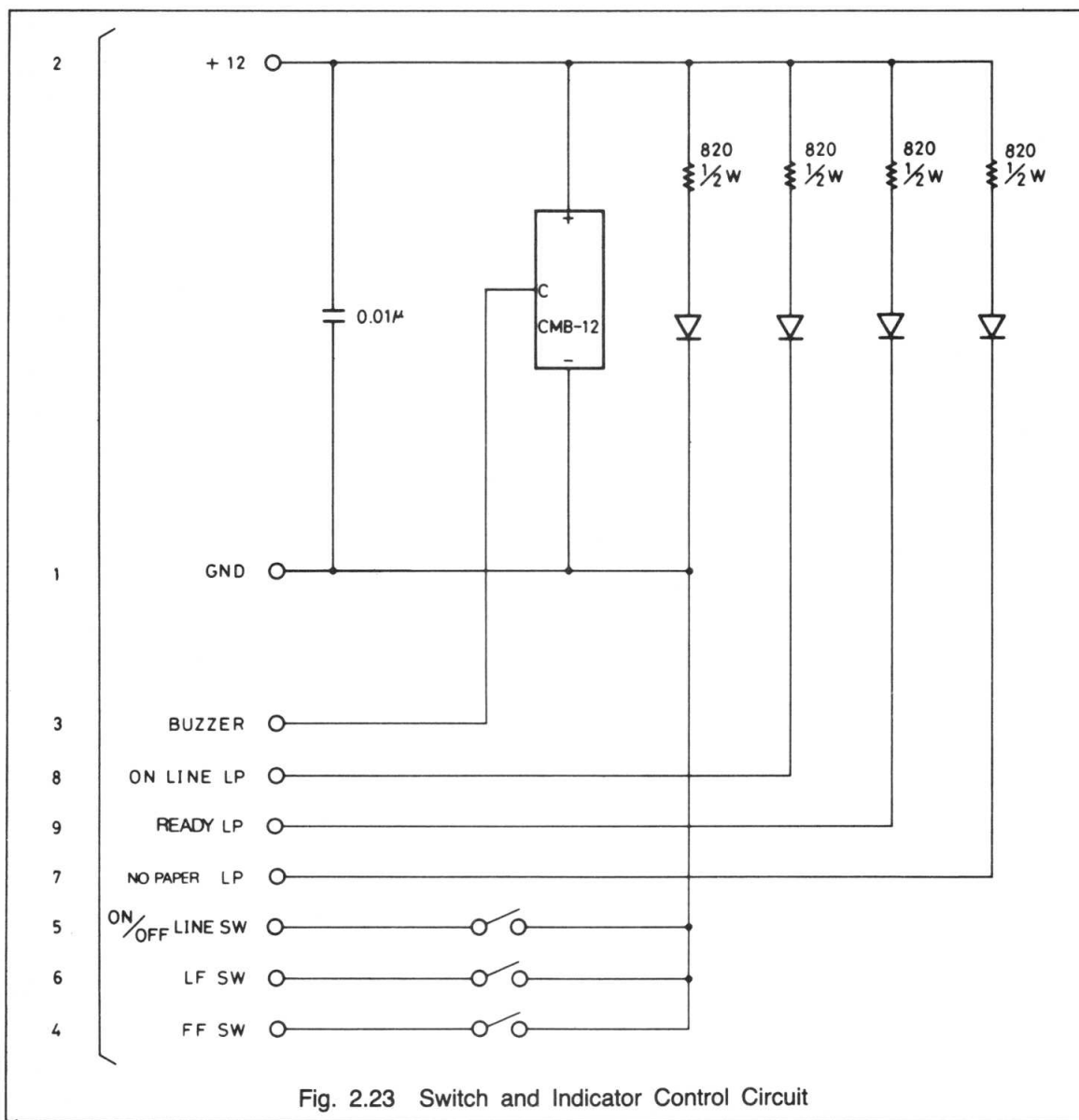

Fig. 2.23 Switch and Indicator Control Circuit

2.5 Operating Principles of Printer Mechanism

The M-3360 Printer Mechanism can be broadly divided into the following six functional blocks.

- (1) Print head mechanism
- (2) Head carriage mechanism
- (3) Paper feeding mechanism
- (4) Ribbon feeding mechanism
- (5) Detecting mechanism
- (6) Frame section

2.5.1 Head carriage and paper feeding mechanisms

The operations of all the above mechanisms except the frame section are basically controlled by the two stepper motors which are driven by two two-phase excitation signals. The turning force from each motor is decelerated by a simple gear train and is conveyed to the timing belt for head carriage driving or sprocket wheel for paper feeding, respectively. These stepper motors are 4-phase, 48-pole motors. The angle of revolution per phase of each motor corresponds to the movement of the sprocket wheel or timing belt as follows:

- (1) One phase of paper feeding stepper motor 1/216 inch (0.12 mm)
- (2) One phase of carriage stepper motor 1/60 inch (0.42 mm)

2.5.2 Print head

The print head is the life and soul of the MX-100 dot matrix printer and serves as the nucleus of the printer operations. The operating principle of the print head is simple as explained below by referring to Fig. 2.24.

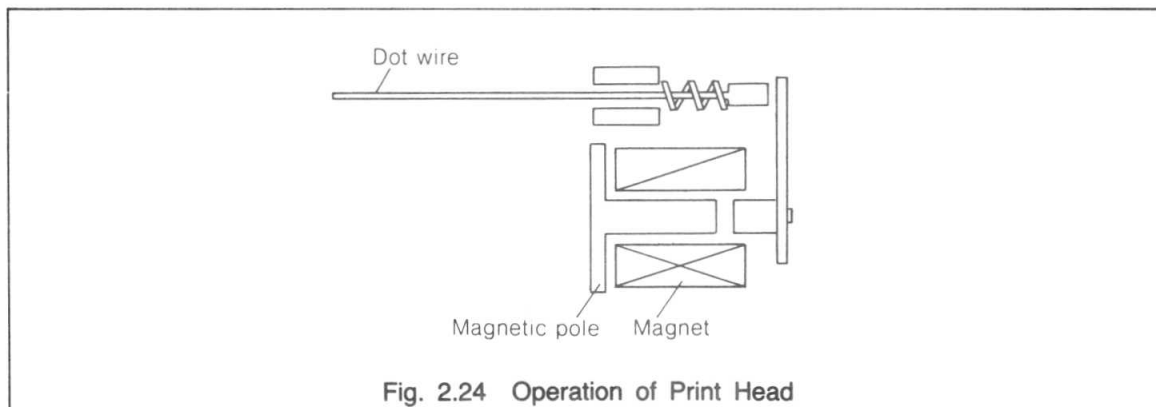

Fig. 2.24 Operation of Print Head

When the current with a pulse width of approx. 400 μsec is applied to the magnet, the magnetic actuator is attracted to the magnet, thus causing the collar portion of the dot wire to be pushed out against the force of the spring. The clearance between the actuator and each dot wire has been adjusted so that the dot wire protrudes about 0.6 mm when its collar portion is pushed. The dot wire thus protruded in the direction of the arrow strikes the paper through the inked ribbon and is caused to return to its original position by the action of the spring and the reaction of its impact against the paper.

2.5.3 Ribbon feeding mechanism

When the timing belt for head carriage driving rotates, a train of planetary pinions are rotated by the belt driving pulley causing the ribbon driving gear intermeshing with one of the planetary pinion train to rotate to feed the inked ribbon in the cartridge case. Therefore, when the head carriage is not in operation, ribbon feeding is not performed.

The inked ribbon in the cartridge case is an endless ribbon and is used until the ink impregnated in the ribbon depletes. When the printed characters are faint due to the ink depletion, the cartridge case or just the endless ribbon in the cartridge case may be replaced. Replacement of the endless ribbon should be limited preferably to a maximum of 5 times per cartridge case to maintain the desirable print quality for an extended period.

2.5.4 Detecting mechanism

The M-3360 has two main sensors to detect the printer operations; one to determine whether or not the print head is at the left end home position to start printing and the other to determine the position of the print head driven by the carriage stepper motor.

The home position sensor assembly is located at the lower left end of the M-3360 to determine the home position of the print head. As the print head moves and approaches the vicinity of the left end of the Printer, a signal is generated when the screen plate protruding from the bottom of the print head passes across the photocoupler.

The PTS sensor board assembly is secured to the motor heat sink at the right part of the M-3360. Like the home position sensor, a signal is generated when the slit disc which is provided with slits along its circumference and coaxially secured to the timing belt motor shaft passes across the photocoupler.

2.5.5 Frame section

The frame section consists of two side frames and one base frame, all of which are of unique sheet metal construction to minimize the weight of, as well as to miniaturize, the Printer mechanism. Between the two side frames secured on both sides of the base frame, mechanical components such as carriage assembly, paper feeding mechanism, ribbon feeding mechanism, etc., are compactly arranged to form the M-3360 printer mechanism.

CHAPTER 3

DISASSEMBLY, ASSEMBLY AND TROUBLESHOOTING

CONTENTS

3.1 General	3-1
3.2 Tools and Measuring Instruments	3-1
3.3 Disassembly and Assembly	3-3
3.3.1 Removal of Upper Case	3-3
3.3.2 Disassembly of electric circuit block	3-5
3.3.3 Disassembly of M-3360 printer mechanism block	3-9
3.4 Symptoms of Trouble and Repair	3-15
3.4.1 General	3-15
3.4.2 Troubleshooting by symptom	3-16
3.4.3 Troubleshooting of control circuit board	3-20

3.1 General

This chapter describes the method of disassembling the EPSON MX-100 Dot Matrix Printer for replacement of major components, and the procedures for troubleshooting the Printer. The troubleshooting procedures are divided into two parts; one related to the mechanism block of the MX-100 and the other related to the electric circuit block of the MX-100. In each part, a troubleshooting method is provided for each symptom of abnormality.

3.2 Tools and Measuring Instruments

The tools and measuring instruments contained in Tables 3.1 and 3.2 of this section must be prepared by the user prior to disassembling and troubleshooting the MX-100. Under the column "Class" in both tables, code "A" denoted the tool or measuring instrument mandatory for maintenance and repair of the Printer, whereas code "B" denotes the tool or measuring instrument not necessarily essential but recommended to facilitate such maintenance and repair.

(1) Commercially available tools

Table 3.1 List of Tools

Name of Tool	Specification	Class
Phillips screwdriver No. 1	75 mm long	A
Phillips screwdriver No. 2	100 mm long	A
Round blade screwdriver No. 1	4 mm wide	B
Hexagonal box driver	7 mm wide across flats	A
Soldering iron	100V (30W)	A
Round nose pliers	150 mm long	B
Retaining plier No. 2.5	ETH-2.5	B
Retaining plier No. 3	ETH-3	B
Retaining plier No. 5	ETH-5	B
Retaining plier No. 6	ETH-6	B
Tweezers	MM 125 mm	A

(2) Shinshu Seiki's adjusting gauge set

Tool No.	Name of Tool	Specification	Class
T-59	Pliers for spring pin		B
T-14	Brush for lubrication No. 1		B
T-15	Brush for lubrication No. 2		B
T-16	Brush for cleaning	15 mm wide	B
T-67	Clearance gauge set		A
T-72	Belt tension adjusting gauge set		B

Table 3.2 List of Measuring Instruments

Name of Tool	Specification	Class
Oscilloscope	50 MHz	A
Tester		A
Multimeter		B
Logic state analyzer		B

3.3 Disassembly and Assembly

In this section, the methods of disassembling the respective major components of the MX-100 are explained step by step with illustrations. Unless otherwise specified in the disassembly procedure for each major component, reassembly of the disassembled parts is performed in the exact reverse manner to the disassembly procedure. Therefore, the methods of assembling the MX-100 are omitted from this section.

The disassembly procedures in this section are divided into three parts: removal of the upper case of the Printer, disassembly of the electric circuit block and disassembly of the M-3360 printer mechanism block. In each part, only the components necessary for the troubleshooting described in section 3.4 are covered.

For detailed information on the disassembly, assembly and adjustment of the major components in the M-3360 printer mechanism, refer to the technical manual separately published for the M-3360.

3.3.1 Removal of upper case

To obtain access to the interior of the MX-100, the upper case of the printer housing must be first removed as follows.

NOTE: Before proceeding to Step 1 below, be sure that the paper is removed from the Printer.

STEP 1. Pull and remove the manual paper feeding knob.

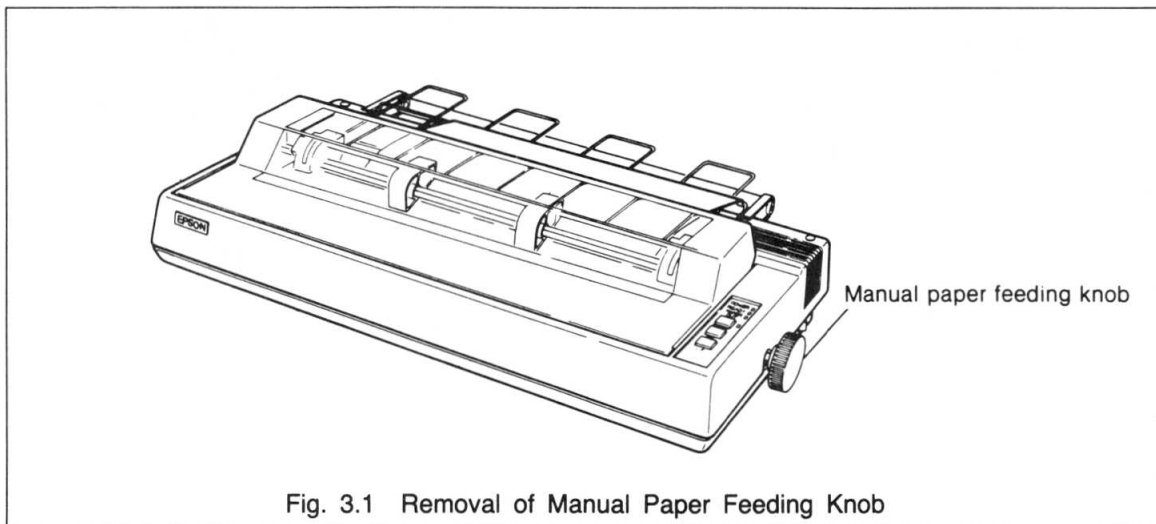

Fig. 3.1 Removal of Manual Paper Feeding Knob

STEP 2. Remove the 5 screws located at the bottom of the case.

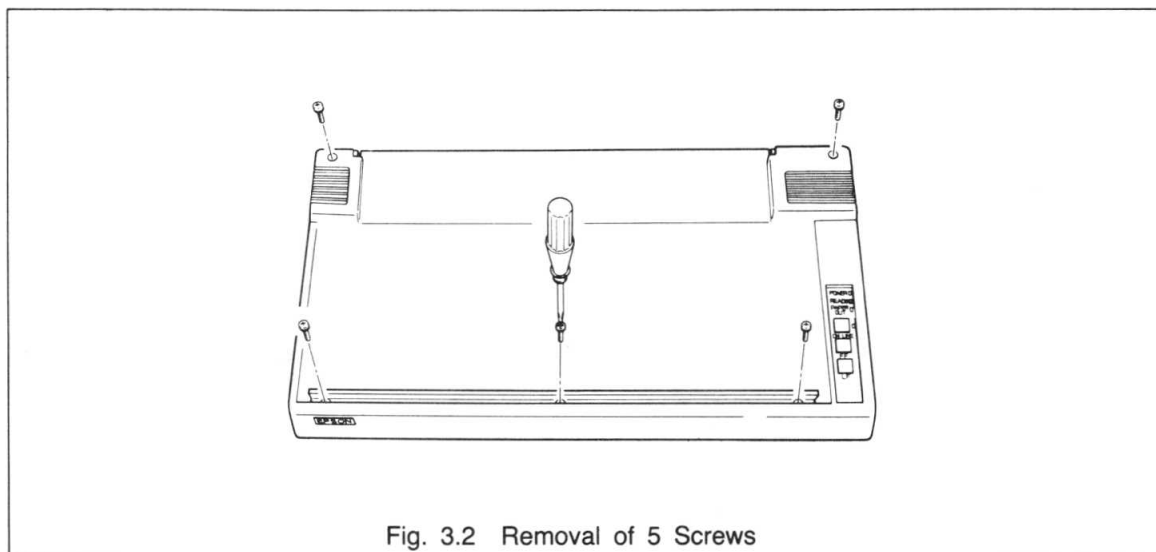

Fig. 3.2 Removal of 5 Screws

- STEP 3. Gently raise the upper case with care not to hit the upper case against the manual paper feeding shaft.
- STEP 4. While raising the upper case, the connector extending from inside to the control panel at the front right corner of the upper case for supply of signals to the switches and indicators is visible. Pull out this connector.
- STEP 5. Take off the upper case.

Fig. 3.3 shows the locations of the respective printer components visible upon removal of the upper case.

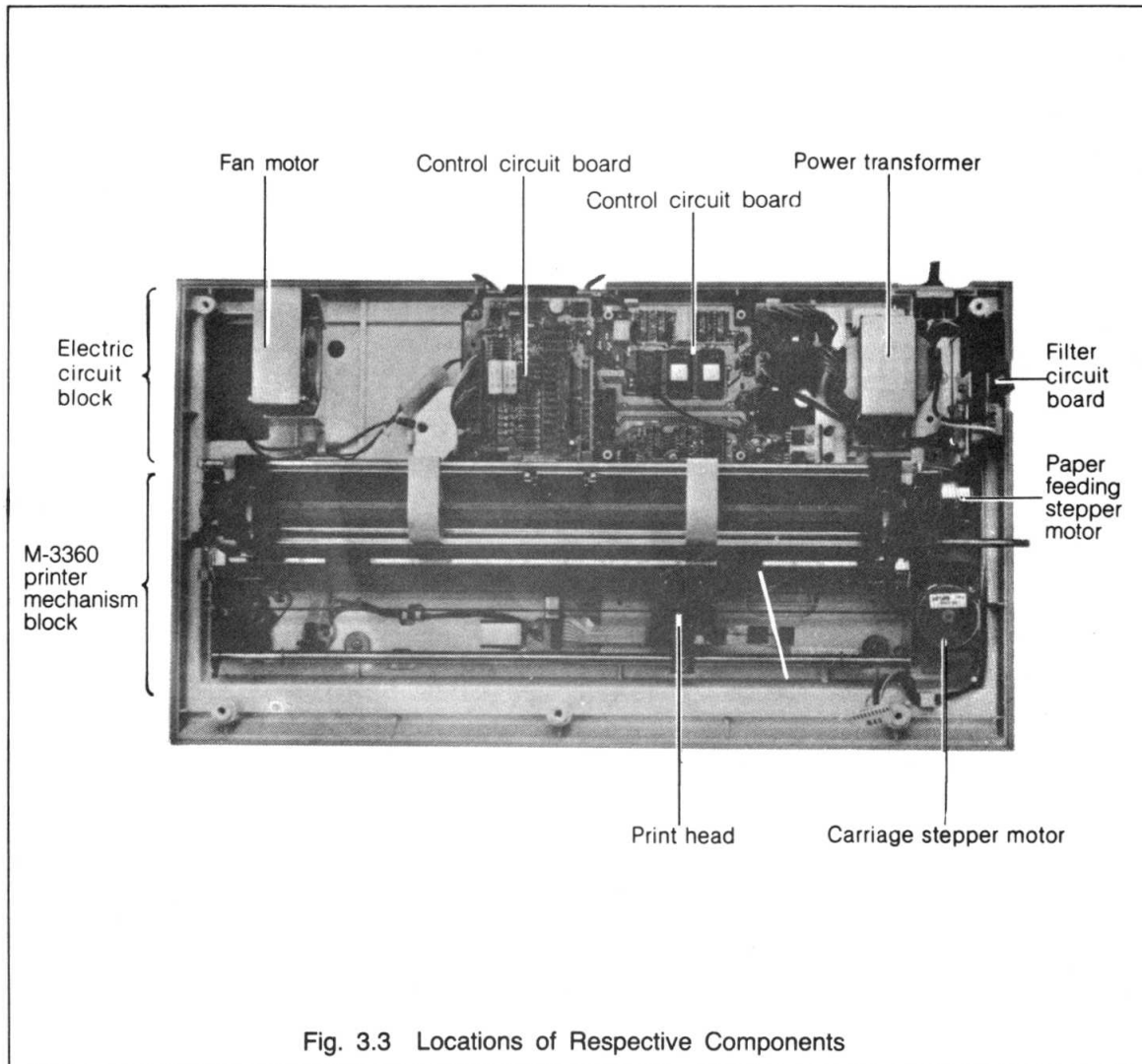

Fig. 3.3 Locations of Respective Components

3.3.2 Disassembly of electric circuit block

The electric circuit block of the MX-100 controls the M-3360 printer mechanism and consists mainly of a driver circuit board, a control circuit board, a power transformer and a fuse and filter circuit board. The disassembly procedures described here for these major circuit components are useful when replacing any circuit components found to be defective as a result of the troubleshooting detailed in section 3.4.

NOTE: Prior to dismantling any of the major circuit components, be sure that the power connector is disconnected from the AC outlet.

(1) Dismounting of driver circuit board

When dismantling the driver circuit board, observe the following procedure.

STEP 1. Unplug the male contact type connector CN6 ① extending from the M-3360 printer mechanism to the driver circuit board. (See Fig. 3.4.)

STEP 2. Remove the two screws ② located by the female contact type connector CN6 ③ to secure the driver circuit board. (See Fig. 3.4.)

STEP 3. Remove the driver circuit board.

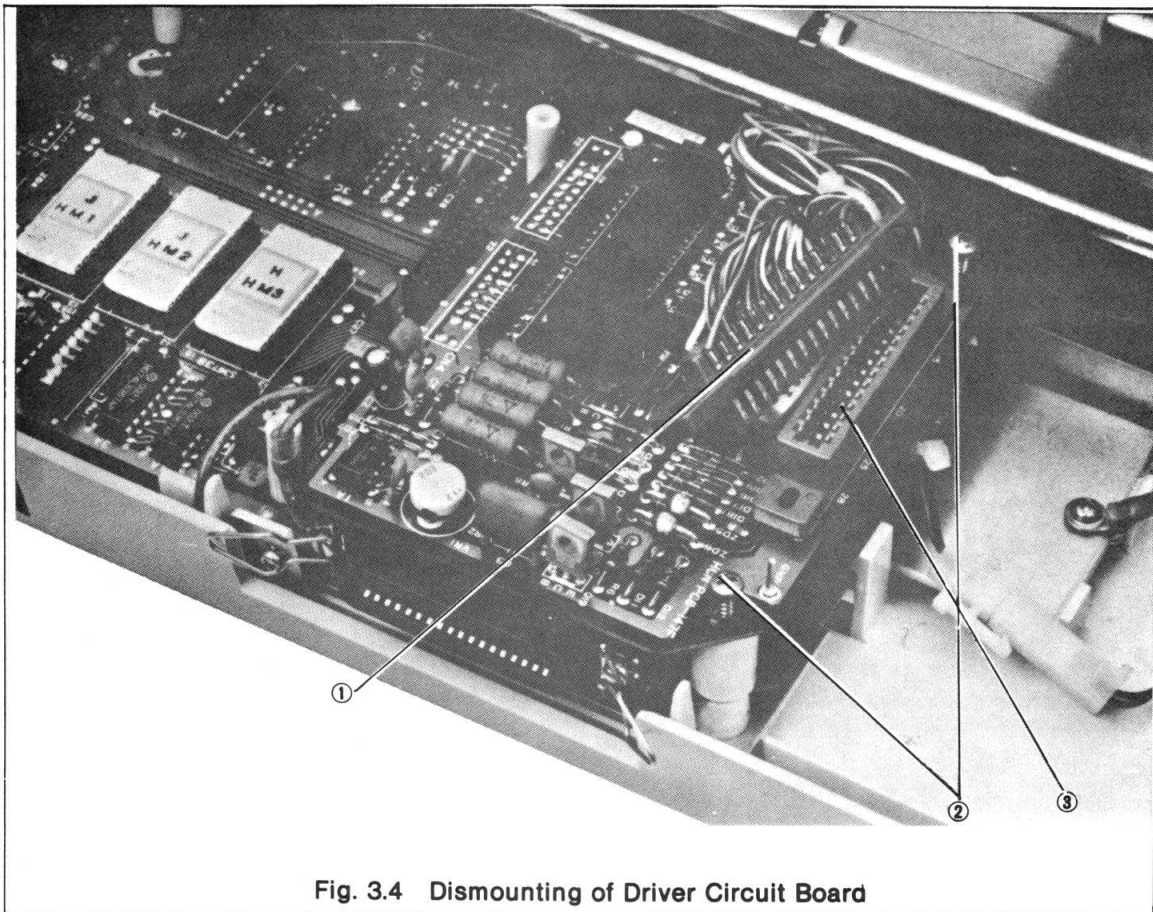

Fig. 3.4 Dismounting of Driver Circuit Board

(2) Dismounting of control circuit board

The control circuit board is regarded as the heart of the electric circuit block of the MX-100, and is equipped with a number of precision circuit components. Therefore, carefully dismount the control circuit board as follows.

STEP 1. Unplug the connector ① extending from the power transformer to the control circuit board also connector ② extending to the fan motor unit and disconnect the connector ③ extending from the line filter to the control circuit board. (See Fig. 3.5.)

STEP 2. Unplug the connector ④ extending from the heat sink to the control circuit board, and remove the screw ⑤ secured to the chassis for collector heat dissipation of the power supply circuit. (See Fig. 3.5.)

STEP 3. Remove the screws ⑥ securing the control circuit board.

STEP 4. Unhook the control circuit board from the lower case (3 places).

STEP 5. Remove the control circuit board.

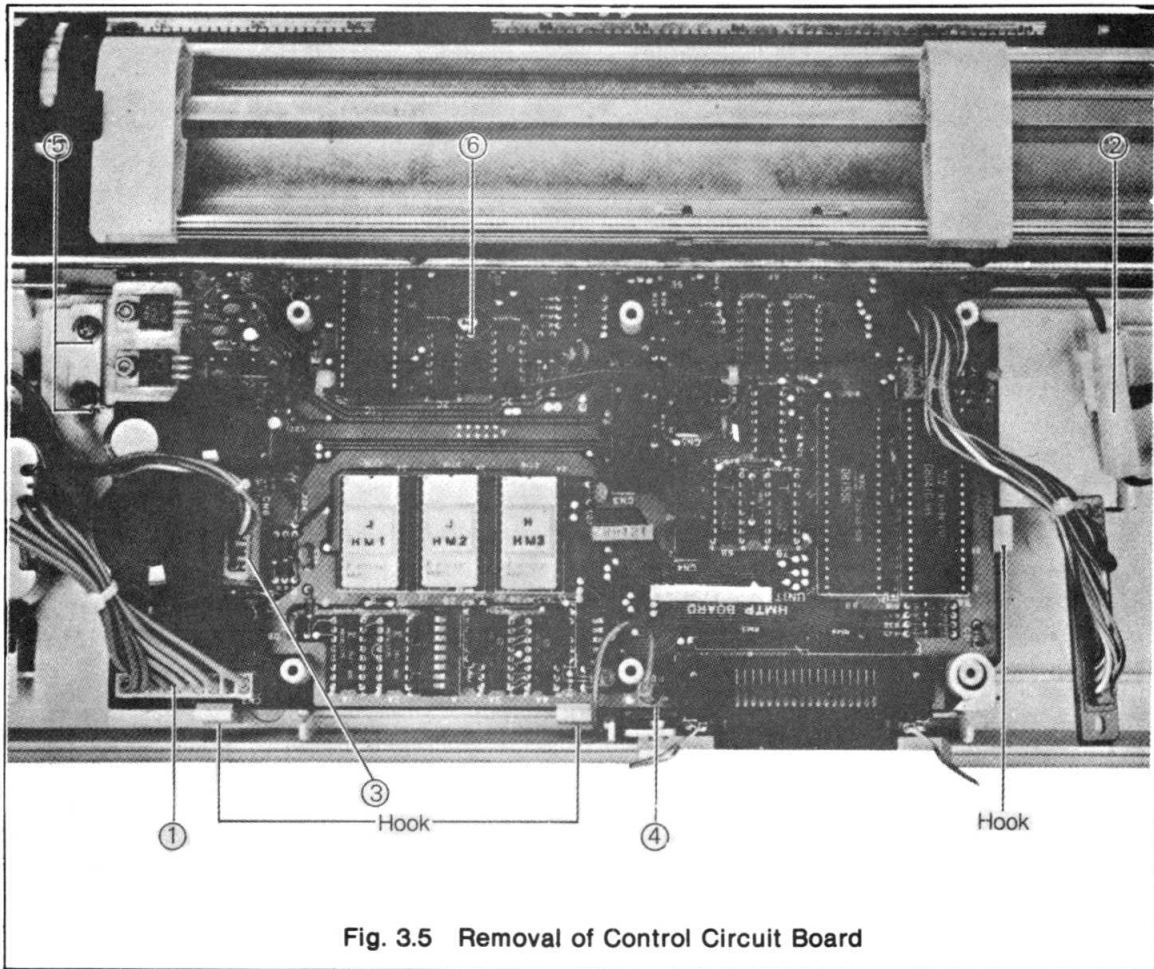

Fig. 3.5 Removal of Control Circuit Board

NOTE: Be sure to keep the removed screws in proper storage to prevent them from being lost.

(3) Dismounting of power transformer

The power transformer is secured to the lower case with two screws, and its electrostatic shield wire on the primary side is also secured to the lower case with a screw. Therefore, the power transformer can be dismantled simply as outlined below.

STEP 1. Unplug the connector ① extending from the power transformer to the fuse and filter circuit board and remove the screw ② securing the electrostatic shield wire. (See Fig. 3.6.)

NOTE: For the 220/240V specification, this shield wire is not provided.

STEP 2. Remove the two screws ③ securing the power transformer. (See Fig. 3.6.)

STEP 3. Remove the power transformer.

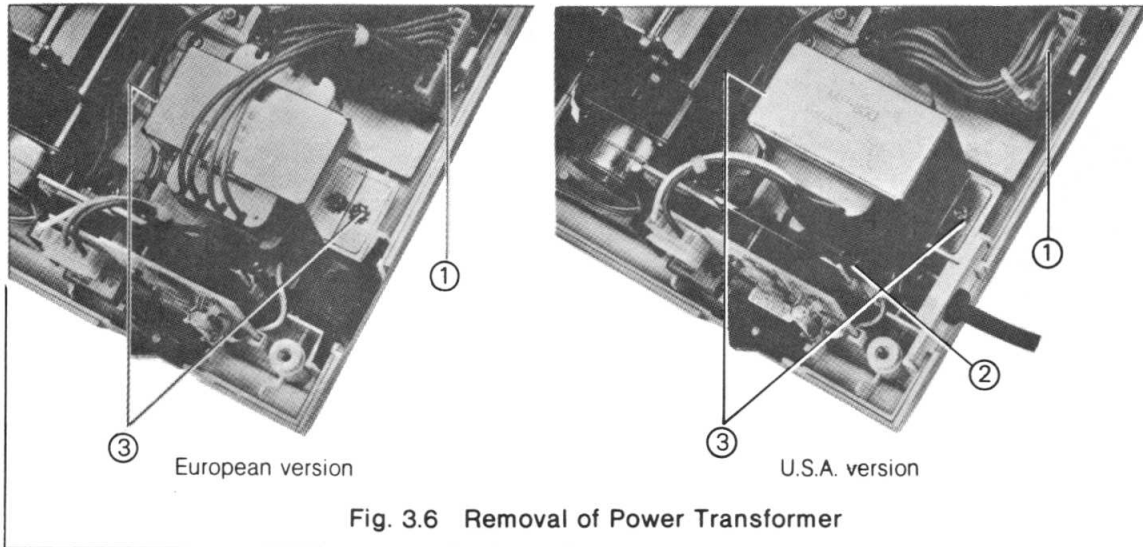

Fig. 3.6 Removal of Power Transformer

(4) Dismounting of fuse and filter circuit board

Dismount the fuse and filter circuit board as follows.

STEP 1. Remove the screw ① securing the ground wire to the lower case. (See Fig. 3.7.)

STEP 2. Remove the "C GND" screw ② on the fuse and filter circuit board. (See Fig. 3.7.)

STEP 3. Lift and remove the fuse and filter circuit board together with the power supply cords.

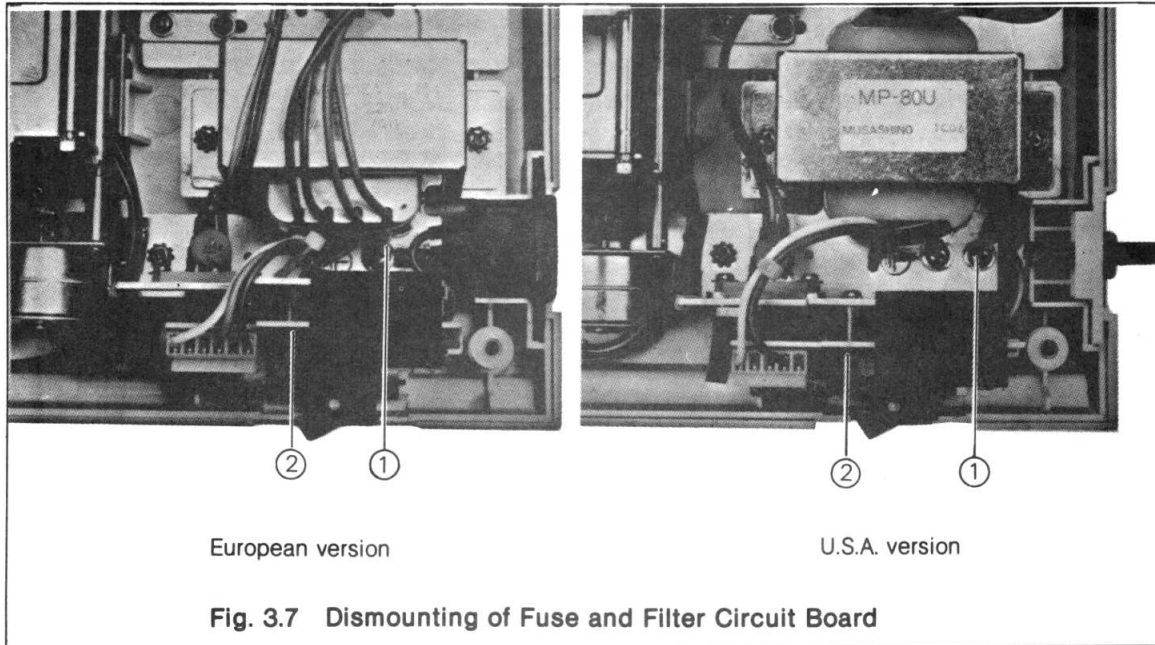

3.3.3 Disassembly of M-3360 printer mechanism block

(1) Dismounting M-3360 printer mechanism

The M-3360 printer mechanism is secured to the lower case of the printer housing with several cup screws. By loosening these screws, the M-3360 can be removed easily from the lower case. Fig. 3.8 shows the locations of the cup screws securing the M-3360.

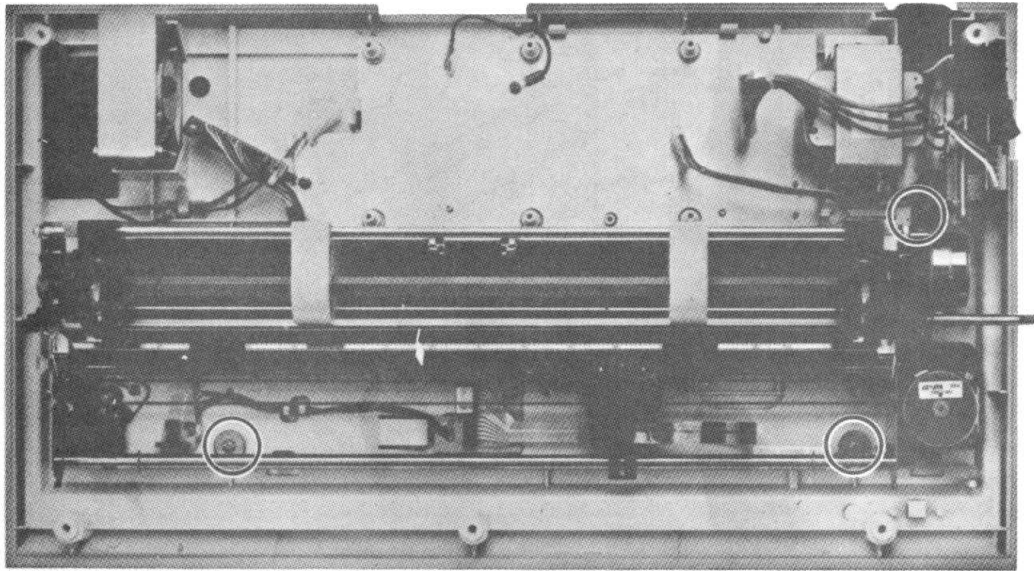

Fig. 3.8 Dismounting of M-3360 Printer Mechanism

(2) Dismounting print head unit

The print head in the print head unit is the life and soul of the MX-100 and has a service life of approx. 100 million characters. If it is necessary to replace the print head due to an accident, etc., the print head unit can be dismantled very easily from the M-3360 printer mechanism as follows. (See Fig. 3.9.)

STEP 1. Manually move the print head unit to the right end.

STEP 2. Remove the head cable (FPC) from the connector on the terminal board.

STEP 3. Turn the head lock lever clockwise and lift and remove the print head unit.

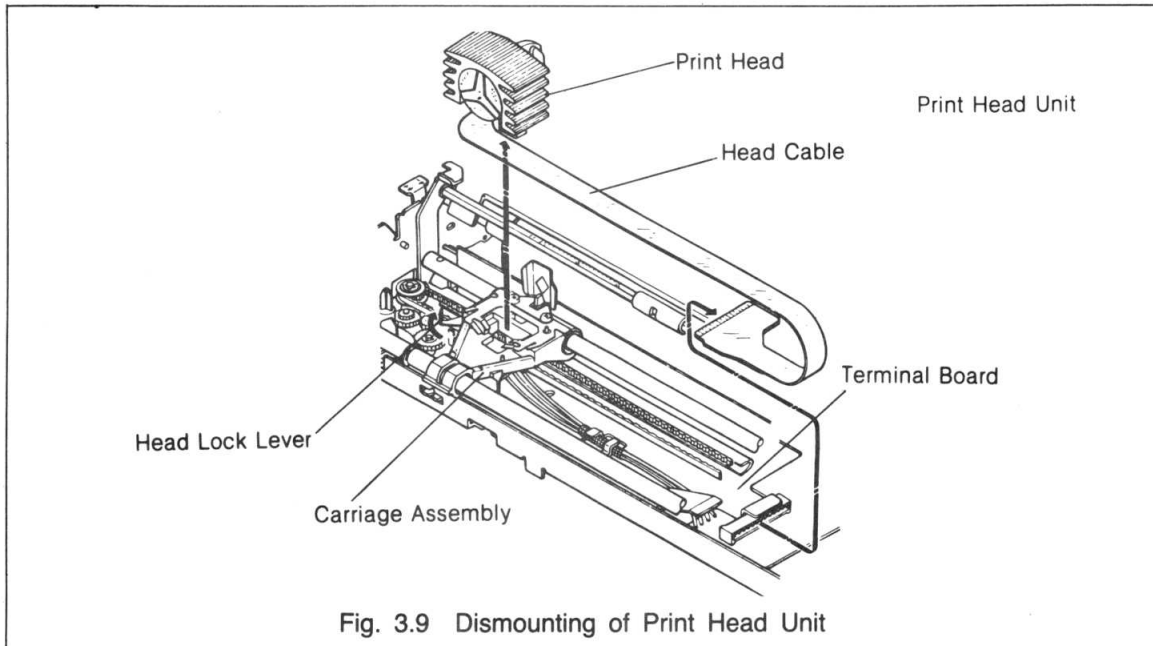

(3) Dismounting of home position sensor assembly

Dismount the home position sensor assembly from the M-3360 printer mechanism as follows.

STEP 1. Unsolder the three lead wires of the home position sensor assembly from the terminal board. (See Fig. 3.10.)

STEP 2. Remove the cup screw (M2.5 x 4) and retaining ring RE (2.3) securing the home position sensor assembly. (See Fig. 3.10.)

STEP 3. Remove the home position sensor assembly.

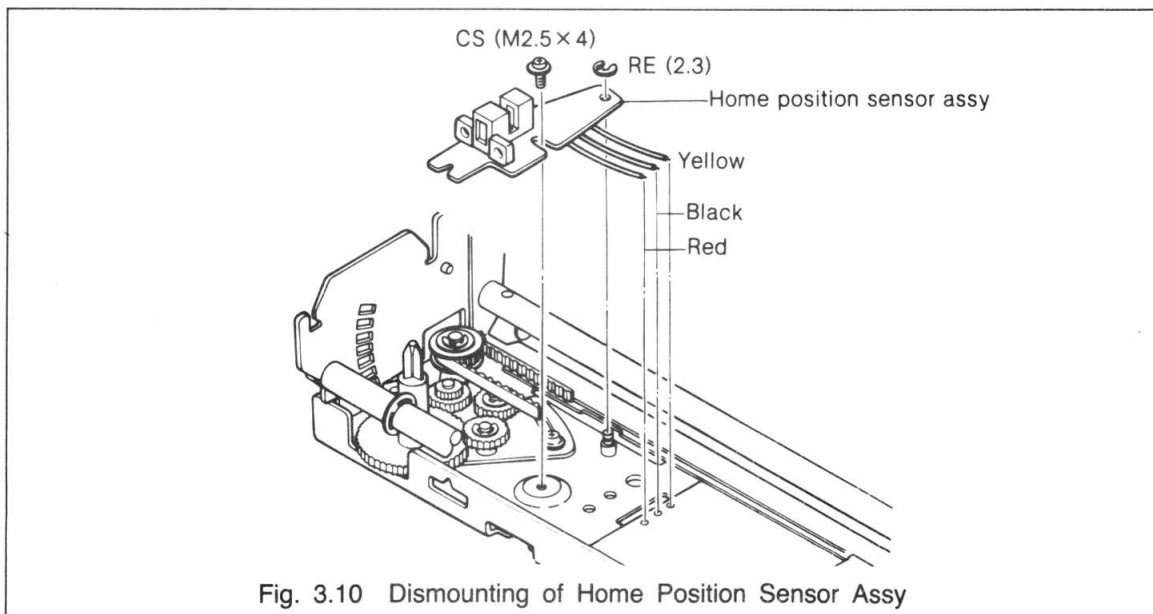

(4) Dismounting of PTS sensor board assembly

Dismount the PTS sensor board assembly from the M-3360 printer mechanism as follows.

STEP 1. Unsolder the four lead wires of the PTS sensor board assembly. (See Fig. 3.11.)

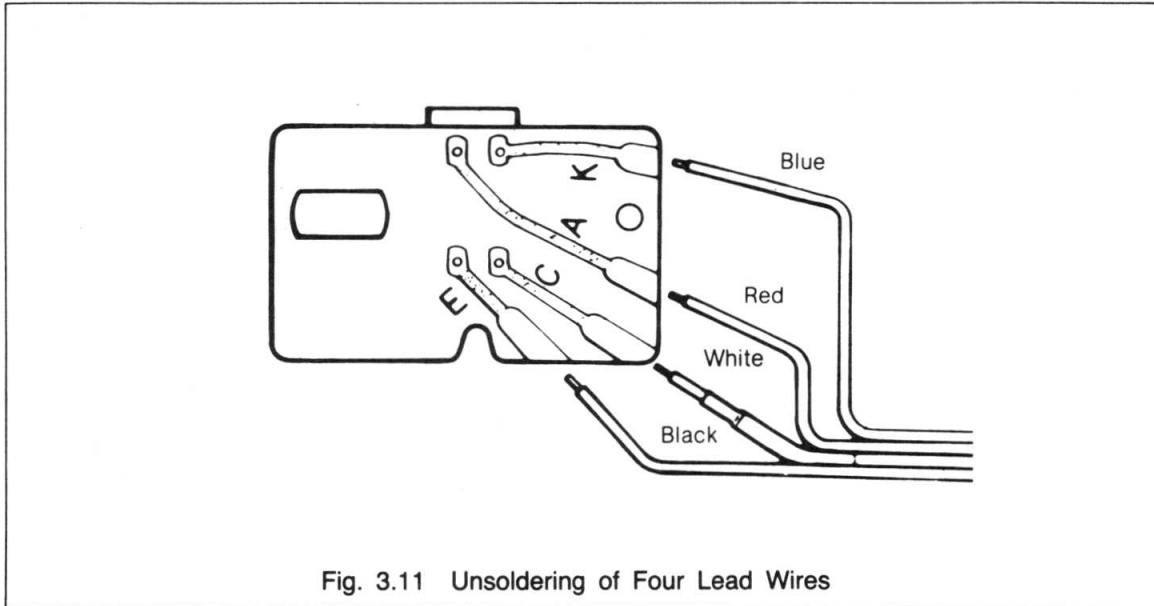

Fig. 3.11 Unsoldering of Four Lead Wires

STEP 2. Remove the cup screw securing the PTS sensor board assembly to the motor heat sink. (See Fig. 3.12.)

STEP 3. Remove the PTS sensor board assembly.

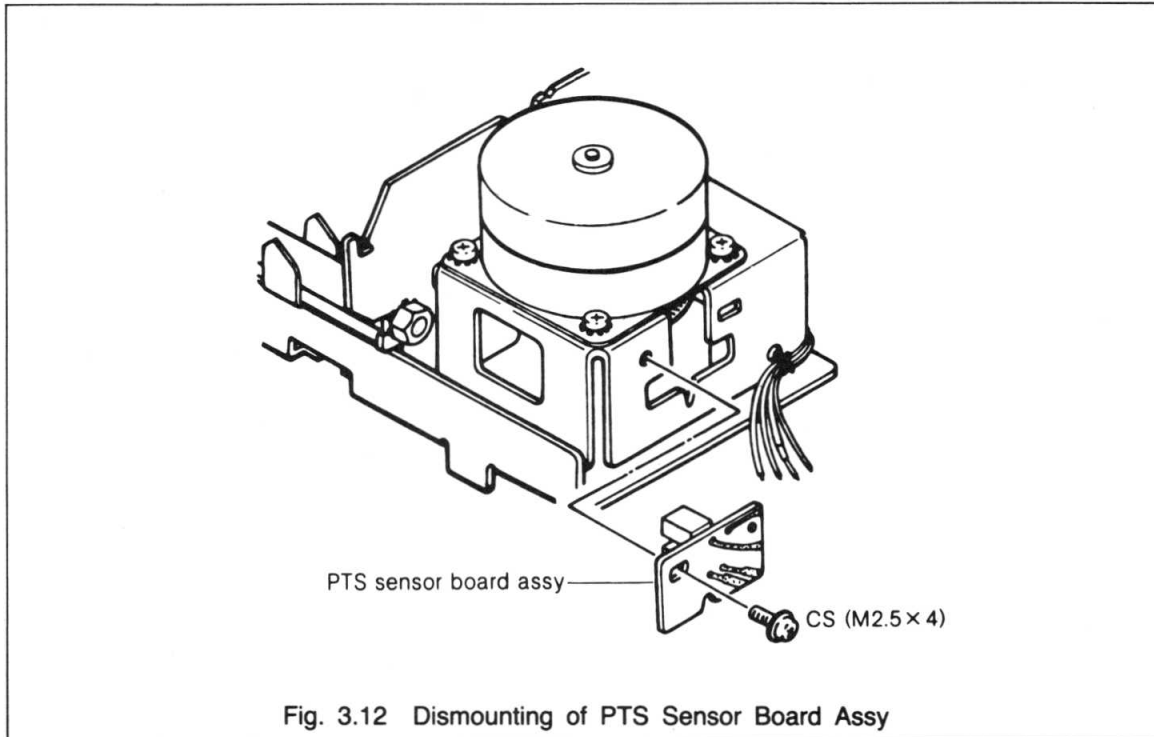

Fig. 3.12 Dismounting of PTS Sensor Board Assy

(5) Dismounting of timing belt motor assembly

Dismount the timing belt motor assembly (i.e., carriage stepper motor) as follows.

STEP 1. Dismount the M-3360 printer mechanism in accordance with paragraph 3.3 (1) above.

STEP 2. Untie the wire band securing the bundle of lead wires supplying signals to the timing belt motor. (See Fig. 3.13.)

STEP 3. Remove the four cup screws (M2.5 x 4) securing the timing belt motor assembly to the motor heat sink. (See Fig. 3.13.)

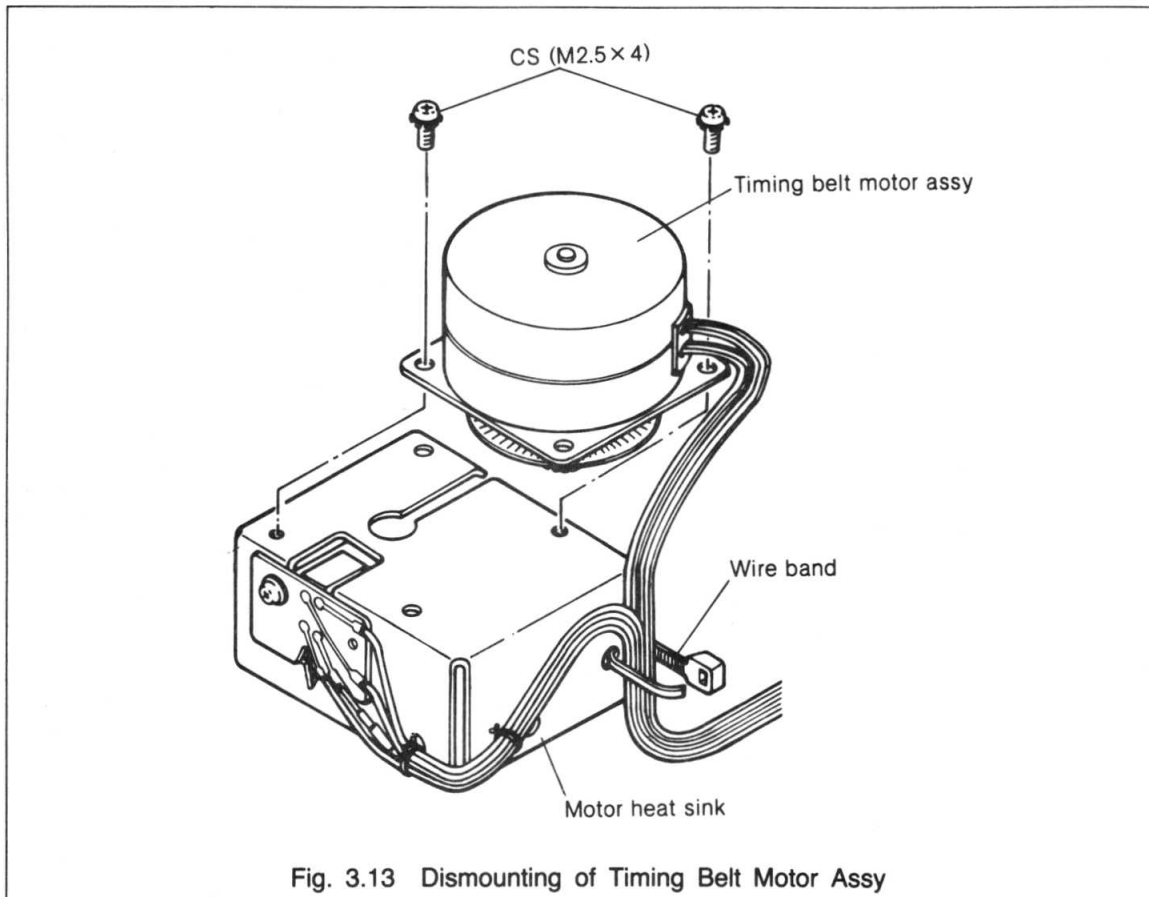
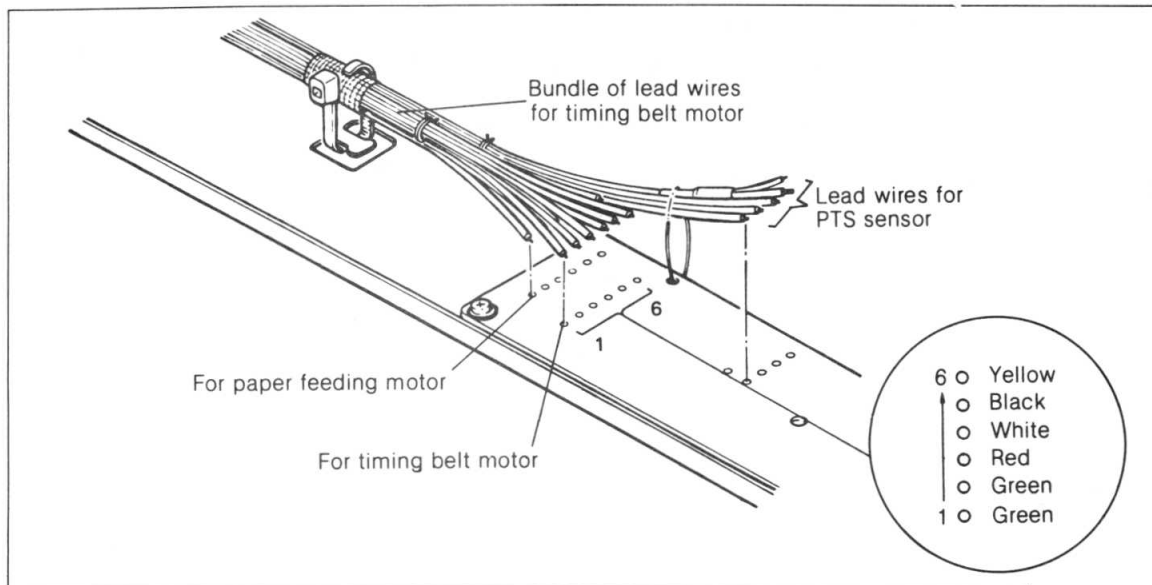

Fig. 3.13 Dismounting of Timing Belt Motor Assy

STEP 4. Unsolder the six lead wires for the timing belt motor from the terminal board. (See Fig. 3.14.)

STEP 5. Remove the timing belt motor assembly.



(6) Dismounting of paper feeding motor assembly

Dismount the paper feeding motor assembly as follows.

- STEP 1. Dismount the M-3360 printer mechanism in accordance with paragraph 3.3 (1) above.
- STEP 2. Untie the wire band securing the bundle of lead wires supplying signals to the paper feeding motor.
- STEP 3. Unsolder the six lead wires for the paper feeding motor from the terminal board. (See Fig. 3.14.)
- STEP 4. Remove the two cup screws (M2.5 x 4) securing the paper feeding motor assembly. (See Fig. 3.15.)

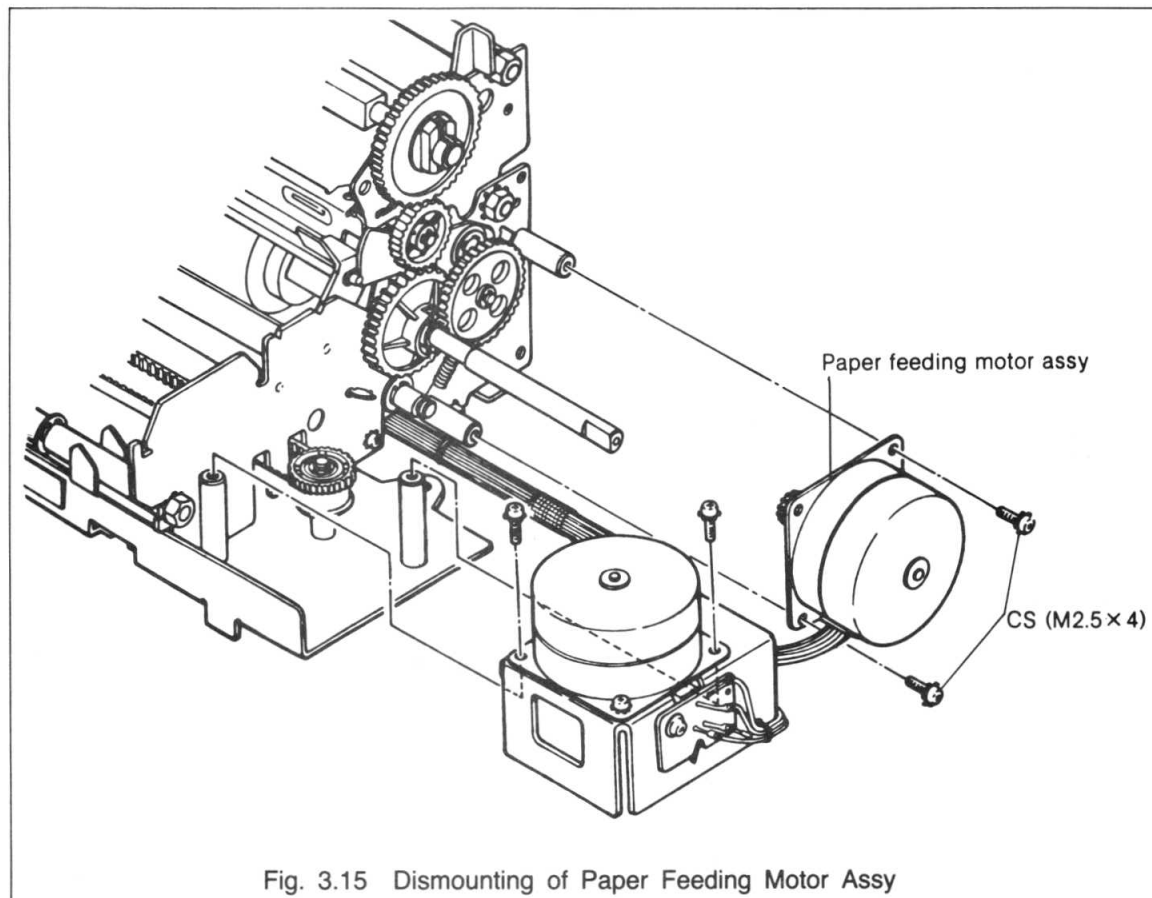

Fig. 3.15 Dismounting of Paper Feeding Motor Assy

(7) Dismounting of PE board assembly

The PE (paper end) board assembly for paper end detection consists of a magnet and a reed switch. Dismount the PE board assembly as follows.

STEP 1. Unsolder the two lead wires from the PE board assembly. (See Fig. 3.16.)

STEP 2. Unhook the PE lever spring from the outer paper guide. (See Fig. 3.16.)

STEP 3. Remove the PE board assembly.

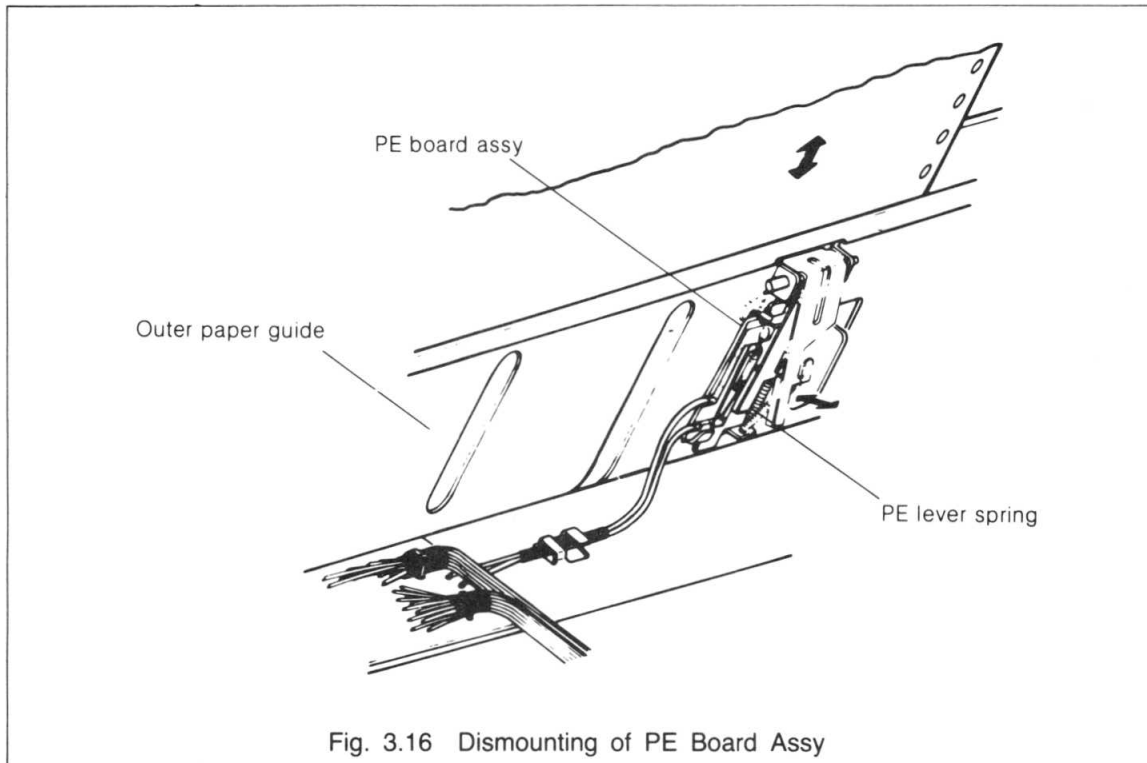

Fig. 3.16 Dismounting of PE Board Assy

3.4 Symptoms of Trouble and Repair

3.4.1 General

This section describes the major symptoms of trouble with the MX-100, the probable causes of trouble when each symptom appears, the check points to locate specific defects and the repair method to correct the defects mainly by replacing and/or adjusting defective components.

In the troubleshooting method described for each symptom in paragraph 3.4.2, if any trouble is discovered to be attributable to a defect in the control circuit board, further analysis of the defective control circuit board can be made by referring to paragraph 3.4.3 (Troubleshooting of control circuit board), to find out which one of main IC's (8049, 8155 and 8041) attached to the IC sockets is defective. By merely replacing any defective main IC on the control circuit board, troubleshooting of the control circuit board may be completed. However, since these IC's perform data transfer mutually, it may be necessary to employ a cut-and-try method to some extent, in troubleshooting them.

The troubleshooting methods described in this section premise the following. Should any electrical or mechanical part of the MX-100 fail, the defective part is reparable by replacement in units of components as shown in Table 3.3 or 3.4.

With respect to the M-3360 printer mechanism, components may also be supplied individually for parts replacement by trained personnel who have sufficient knowledge of the operating principles of the M-3360, as well as the disassembly, assembly and adjustment procedures of the printer mechanism. Refer to the Technical Manual of the M-3360 Printer Mechanism for detailed information on the operating principles, maintenance and repair of the printer mechanism. In this manual, however, it should be noted that when troubleshooting the M-3360 printer mechanism, only its major components listed in Table 3.4 are subject to replacement.

Table 3.3 Replaceable Circuit Components

Name of component	Part number
Filter circuit board unit	G490302000 (115V) G490301001 (220/240V)
Power transformer set	G490307000 (115V) G490306000 (220/240V)
Driver circuit board	G490202000
Control circuit board (including 8049, 8155 and 8041)	G490201001
8049 (CPU)	
8155 (RAM and I/O)	A101681551
8041 (slave CPU)	
Control panel	G490203000

Table 3.4 Replaceable Mechanical Components

Name of component	Part number
Home position sensor assy	F303030000
PTS sensor board assy	F303029000
Timing belt motor assy	F303027000
Paper feeding motor assy	F303031000
PE board assy	F303009000
Print head unit	F401100000

3.4.2 Troubleshooting by symptom

SYMPTOM 1

The printer does not operate nor any indicator on the control panel light when the power switch is turned on.

No.	Cause of Trouble	Check Point	Repair Method
1	Blown fuse	<ul style="list-style-type: none"> Check the fuse and filter circuit board to see if the fuse has blown out. 	<ul style="list-style-type: none"> If blown, replace the fuse with a new one. If the newly inserted fuse still blows out, the cause of trouble exists in other parts. Check items 2 and 3 below.
2	Defective fuse and filter circuit	<ul style="list-style-type: none"> If the fuse is normal, disconnect the connector on the primary side of the power transformer and check with a tester if 115, 220 or 240V AC is present between pin Nos. 1 and 5. 	<ul style="list-style-type: none"> In the absence of the proper primary voltage, replace the fuse and filter circuit board with a new one. See paragraph 3.3.2 (4) for replacement.
3	Defective power transformer	<ul style="list-style-type: none"> If the primary AC voltage is normal, disconnect the connector on the secondary side of the power transformer and check with a tester for proper secondary voltages. Voltage between pins 1 and 2: 10V AC Voltage between pins 3 and 4: 25V AC Voltage between pins 5 and 6: 10V AC Voltage between pins 7 and 8: 16V AC 	<ul style="list-style-type: none"> In the absence of proper secondary voltages, replace the defective power transformer. See paragraph 3.3.2 (3) for replacement.

SYMPTOM 2

None of the indicators on the control panel lights although the secondary voltages of the power transformer are normal.

No.	Cause of Trouble	Check Point	Repair Method
1	Broken signal line between the control panel and control circuit board	<ul style="list-style-type: none"> Check the 9 respective lead wires extending from the control circuit board to the control panel, for any broken lead. <div style="text-align: center; margin-top: 10px;"> <p>White Gray Purple Blue Yellow Orange Red Brown Black</p> </div>	<ul style="list-style-type: none"> Repair the broken lead wire with a soldering iron.

SYMPTOM 3

The carriage assembly moves properly, but none of the 9 dot wires operate to print a dot.

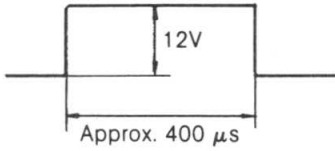
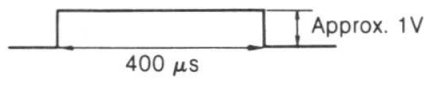
No.	Cause of Trouble	Check Point	Repair Method
1	Faulty head driving pulse width, or no head driving pulse is output.	<ul style="list-style-type: none"> Check the terminal T0 on the driver circuit board with an oscilloscope, for proper voltage and pulse width. 	<ul style="list-style-type: none"> If the pulse width is abnormally short (less than 200 μs), adjust VR1 so that the pulse width becomes 400 μsec at 24V DC. See paragraph 4.3.1. (Refer to Fig. 5.4 for the location of VR1.) If no pulse is output, the control circuit board is defective. See paragraph 3.4.3.
2	No drive signal is input to the head driver.	<ul style="list-style-type: none"> Check the base of each of the 9 head driving transistors (Q1–Q9) for proper input voltage. 	<ul style="list-style-type: none"> If no signal is input, control circuit board is defective. See paragraph 3.4.3.

SYMPTOM 4

The carriage assembly moves properly, but some of the dot wires do not operate to print dots.

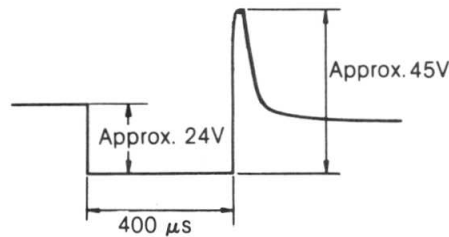
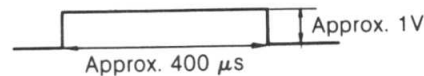
No.	Cause of Trouble	Check Point	Repair Method
1	Defective print head unit	<ul style="list-style-type: none"> Check the driving transistor (Q1–Q9) of each dot wire that does not operate, for proper driving voltage waveform. 	<ul style="list-style-type: none"> If the waveform is normal, the print head unit is defective. Replace it with a new one. See paragraph 3.3.3 (2) for replacement.
2	Defective driver circuit	<ul style="list-style-type: none"> If the waveform is abnormal in the above check, check the driving transistor of each dot wire that does not operate, for proper base voltage. If no collector voltage is output in the above two checks, check the Pin No. 13 of CN6 for output of +24V (in normal character print mode). 	<ul style="list-style-type: none"> If the base voltage is properly input, the driver circuit board is defective. Replace it with a new one. See paragraph 3.3.2 (1) for replacement. If +24V is not output, the driver circuit board is defective. Replace it with a new one. See paragraph 3.3.2 (1) for replacement.

SYMPTOM 5

The carriage assembly does not operate at all.

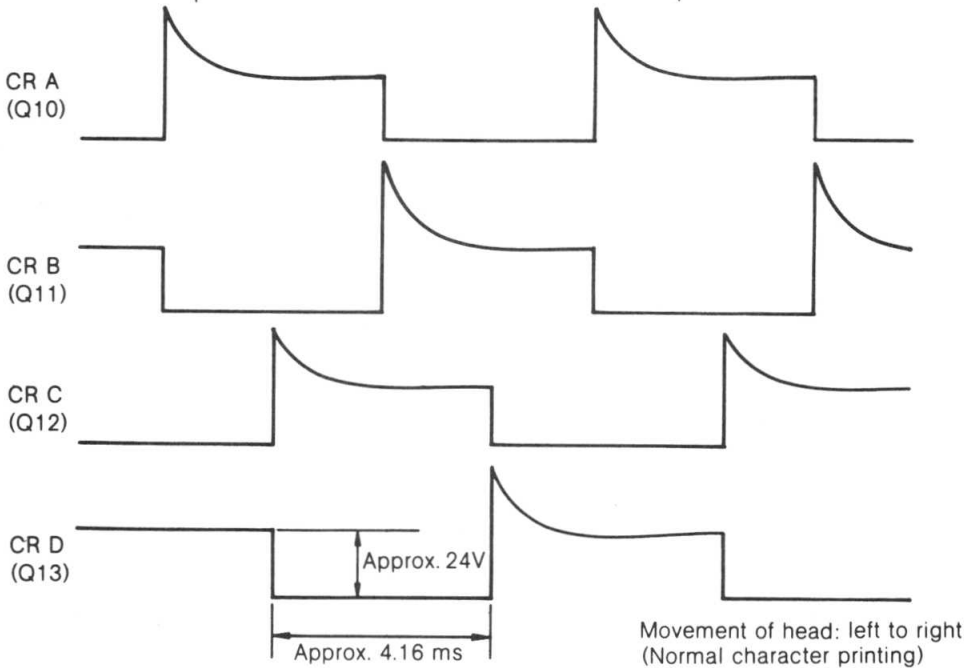
No.	Cause of Trouble	Check Point	Repair Method
1	Defective timing belt motor assy	<p>●If timing signal is output at Pin No. 1 of 8041, check the four carriage driving transistors (Q10–Q13) for normal collector waveform output (at Pin Nos. 21–24 of CN6).</p>  <p>CR A (Q10)</p> <p>CR B (Q11)</p> <p>CR C (Q12)</p> <p>CR D (Q13)</p> <p>Approx. 24V</p> <p>Approx. 4.16 ms</p> <p>Movement of head: left to right (Normal character printing)</p>	<p>●If the collector waveform is normal (proper voltage is output for each phase), the timing belt motor is defective. Replace it with a new one. See paragraph 3.3.3 (5) for replacement.</p>
2	Defective control circuit board	<p>●If the collector waveform is abnormal (proper voltage is not output for each phase) in the above check, check each carriage driving transistor for output of normal base voltage.</p>	<p>●If no base voltage is properly output, the control circuit board is defective. Refer to paragraph 3.4.3.</p>
3	Defective PTS sensor board assy	<p>●If timing signal is not output at Pin No. 1 of 8041, check PTS sensor board for abnormality.</p>	<p>●If defective, replace the PTS sensor board assy. See paragraph 3.3.3 (4) for replacement.</p>

SYMPTOM 6

Paper feeding is not performed at all or the paper feeding motor vibrates and is not operating properly.

No.	Cause of Trouble	Check Point	Repair Method
1	Defective paper feeding motor assy or driver circuit board	<ul style="list-style-type: none"> •If PTS sensor board is not defective in the above check, check the four line feed driving transistors (Q14–Q17) for normal collector waveform output (at Pin Nos. 25–28 of CN6). 	<ul style="list-style-type: none"> •If the collector waveform is normal (proper voltage is output for each phase), the paper feeding motor is defective. Replace it with a new one. See paragraph 3.3.3 (6) for replacement.

The diagram shows four waveforms labeled LFA (Q14), LFB (Q15), LFD (Q17), and LFC (Q16). Each waveform shows a sharp rise followed by a smooth decay. LFA and LFB are 180 degrees out of phase. LFC and LFD are 180 degrees out of phase. A specific pulse on LFC is highlighted with a vertical arrow indicating a 24V amplitude and a horizontal arrow indicating a pulse width of approximately 8.4 ms.

- If the collector waveform is abnormal (proper voltage is not output for each phase), the driver circuit board is defective. Replace it with a new one. See paragraph 3.3.2 (1) for replacement.

3.4.3 Troubleshooting of control circuit board

When troubleshooting the control circuit board, it is unnecessary to look into each component on the control circuit board. The electric circuit components that can be replaced by the user are limited to those shown in Table 3.3. Therefore, other circuit elements must be left intact unless the user has received special training on the handling of electric circuitry.

In this paragraph, a process of finding out which one of the components on the control circuit board should be replaced is described if any trouble with the MX-100 is attributable to the control circuit board. As previously mentioned in paragraph 3.4.1, troubleshooting of the control circuit board can be completed by replacing one of the following major components shown in Table 3.5. In this case, the driver circuit board must be removed to observe signals from main IC's 8041, 8155, etc., since the control circuit board is located beneath the driver circuit board.

Table 3.5 Major Components on Control Circuit Board

Name of component	Part number
8049 (CPU)	
8155 (RAM and I/O)	A101681551
8041 (slave CPU)	
Control circuit board (including 8049, 8155 and 8041)	G490201001

As a result of troubleshooting the control circuit board by the methods described below, if no defective circuit element can be discovered, replace the entire control circuit board including all IC's, with a new one to solve the trouble with the control circuit board.

NOTE: Circuit elements such as 8049, 8155, etc. are extremely complicated in construction, and trouble with those elements may not necessarily be detectable by the methods described below. To perform sufficient check, consultation of the data sheet of each LSI is recommended.

(1) Trouble with 8049

Trouble with the 8049 can be discovered by checking the following two output signals from the 8049. If either signal is not properly output, replace the 8049 with a new one.

(a) Signal $\overline{\text{PSEN}}$ at Pin No. 9

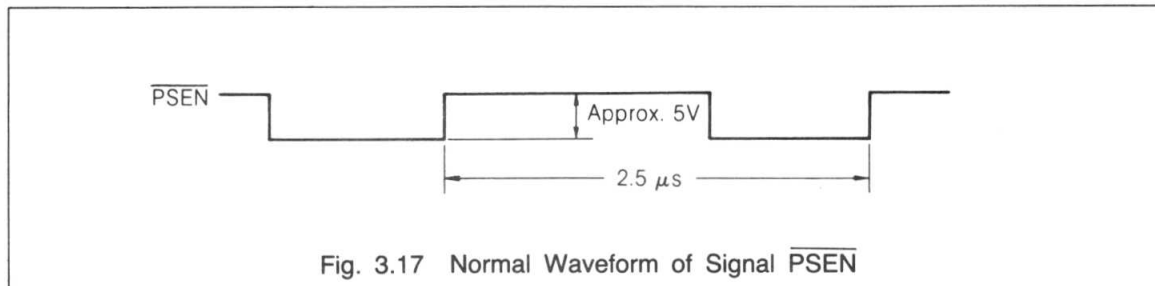

(b) Signal ALE at Pin No. 11

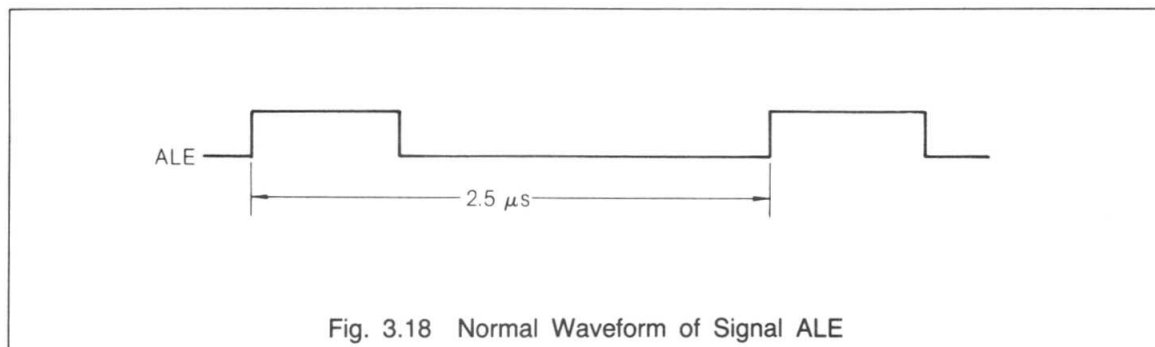

(2) Trouble with 8041

It is difficult to thoroughly troubleshoot the 8041 with the IC mounted on the control circuit board. As one of the methods to troubleshoot the 8041, it is possible to determine whether or not the internal elements of the 8041 are operating, by checking the following signal from the 8041 for normal output.

(a) Signal SYNC at Pin No. 11

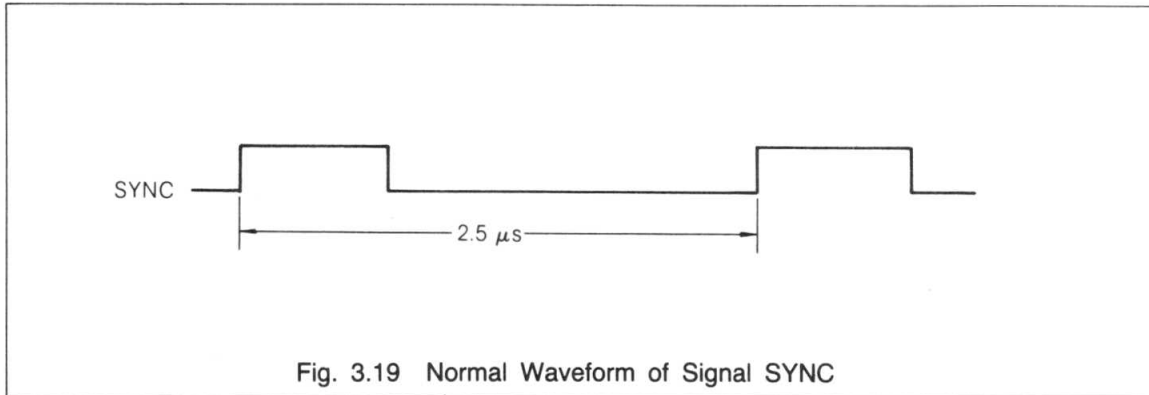

Fig. 3.19 Normal Waveform of Signal SYNC

If signal SYNC is not properly output, replace the 8041 with a new one.

(3) Trouble with 8155

The LSI 8155 is connected with the main CPU 8049 and the slave CPU 8041 on the same bus. Therefore, some difficulties may be encountered in distinguishing troubles peculiar to the LSI 8155 from those peculiar to other LSI's. Since the 8155 controls data transfer between the Printer and an external device, one way to identify the trouble with the 8155 is to check the I/O ports of the LSI for proper input/output of external signals.

Table 3.6

I/O ports	Direction	Voltage at port
PA0 to PA7 (Pin Nos. 21 to 28)	In	Approx. 5V (when the Printer is not connected to an external device)
PB0 to PB7 (Pin Nos. 29 to 36)	In	Approx. 5V (when the print head is not driven)
PC1 (Pin No. 38)	Out (BUSY)	Approx. 5V (when the Printer is busy)
PC2 (Pin No. 39)	In ($\overline{\text{STB}}$)	Approx. 5V (when the Printer is not reading data)
PC3 (Pin No. 1)	Out (SLCT)	Approx. 5V (when the Printer is not in the selected state)
PC4 (Pin No. 2)	Out	Approx. 5V (when the print head is not driven)

NOTES: 1. "Direction" refers to the flow of signal as viewed from the LSI 8155.

2. Be sure to remove the option board before performing the above check.

When any of the voltages measured at the respective ports is abnormal under the condition described in parentheses, the LSI 8155 is considered defective due to the I/O port failure. Replace the defective LSI with a new one.

CHAPTER 4

MAINTENANCE

CONTENTS

4.1 General	4-1
4.2 Lubrication	4-1
4.2.1 Lubricants	4-1
4.2.2 Lubrication standards	4-1
4.2.3 Bonding standards	4-2
4.3 Adjustments	4-4
4.3.1 Adjustment of head driving pulse width	4-4
4.3.2 Adjustment of timing pulse generating position	4-5
4.3.3 Adjustment of phase relationship between timing signal and reset signal	4-6

4.1 General

In this chapter, the maintenance and adjustment procedures for the MX-100 Dot Matrix Printer are described in order to sustain the rated performance characteristics of the Printer for an extended period.

4.2 Lubrication

Lubrication is an important factor in maintaining optimum performance of the M-3360 Printer Mechanism in the MX-100. Perform lubrication in accordance with the procedures outlined in this section.

4.2.1 Lubricants

Performance and durability of the printer are greatly affected by the type of lubricant employed. In particular, attention must be paid to the low temperature characteristic of each lubricant to be used for the printer. The two kinds of lubricants listed in paragraph 4.2.2 have been selected by Shinshu Seiki for exclusive use of the printer based on an extensive study of the technical information on various kinds of lubricants, as well as on a number of tests conducted by the company on such lubricants. For this reason, use of the lubricants designated by Shinshu Seiki is highly recommended.

Shinshu Seiki is prepared to supply the lubricants in a 40 gr. (or 40 cc) metal can or plastic container as a minimum unit of issue.

4.2.2 Lubrication standards

The M-3360 Printer Mechanism employs two kinds of lubricants G-2 and O-2. Before lubricating the M-3360 during its disassembly and assembly, be sure that all points requiring lubrication are thoroughly cleaned, and then perform lubrication by referring to Table 4.1 or Fig. 4.1 for the lube point and the lubricant to be used. (The lube point numbers shown in Table 4.1 are identical to those shown in Fig. 4.1.)

Periodic lubrication of the printer mechanism must be performed in accordance with the following classification.

A . . . requiring lubrication every 6 months or after printing 1,000,000 lines.

B . . . Point requiring lubrication upon overhaul or after printing 5,000,000 lines.

Note that lubrication is mandatory after parts replacement or unit disassembly has been performed or when the lubricant is removed as a result of cleaning.

Table 4.1 List of Lube Points

No.	Lube point	Lubricant used	Lubrication standard
1	Carriage shafts A and B	O-2	A
2	Bearings (for platen)	O-2	A
3	Sliding part of head adjusting lever	G-2	B
4	Toothed part of belt driving pulley	G-2	B
5	Gear teeth of timing belt motor assy	G-2	B
6	Teeth of sprocket transmission gear	G-2	B
7	Gear teeth of paper feeding motor assy	G-2	B
8	Teeth of ribbon driving gear and ribbon driving gear securing shaft	G-2	B
9	Teeth of planetary pinion, contact part between planetary pinion and leaf spring, and planetary pinion securing shaft	G-2	B
10	Toothed part of planetary lever assy and planetary lever assy securing shaft	G-2	B
11	Contact part between belt driven pulley flange and plain washer	G-2	B
12	Teeth of sprocket gear	G-2	B
13	Sliding part of release level L	G-2	B
14	Hook parts of paper feeding spring	G-2	B
15	Sliding part between paper feeding roller shaft and frame	G-2	B
16	Sliding part between sprocket securing lever and sprocket mounting bracket locating shaft	G-2	B

4.2.3 Bonding standards

This adhesive is applied to the set screw and nuts securing the various parts of the M-3360 Printer Mechanism to prevent the assembled parts from loosening due to vibration during the transportation or assembly operation of the Printer. Therefore, whenever the M-3360 is disassembled for part replacement, etc., be sure to apply the Neji Lock #2 (G) to the specified bonding points by referring to Table 4.2 or Fig. 4.1. (The bonding point numbers shown in Table 4.2 are identical to those shown in Fig. 4.1.)

NOTE: Be sure to apply a moderate amount of Neji Lock #2 (G), so as to prevent the parts adjacent to the screw or nut from seizure due to the outflow of the adhesive. Preferably apply the adhesive over 1/2 to 1/4 of the screw and nut heads.

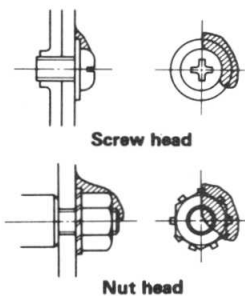

Apply Neji lock over 1/2 to 1/4 of the screw and nut heads. Confirm that the applied adhesive does not enter the cross slot of the screw head.

Table 4.2 List of Bonding Points

No.	Bonding Point
21	Ribbon mask securing screws (2 places)
22	PTS sensor board assy securing screw (1 place)
23	Terminal board securing screws (3 places)
24	Home position sensor assy securing screw (3 places)
25	Belt tension plate securing screw (1 place)

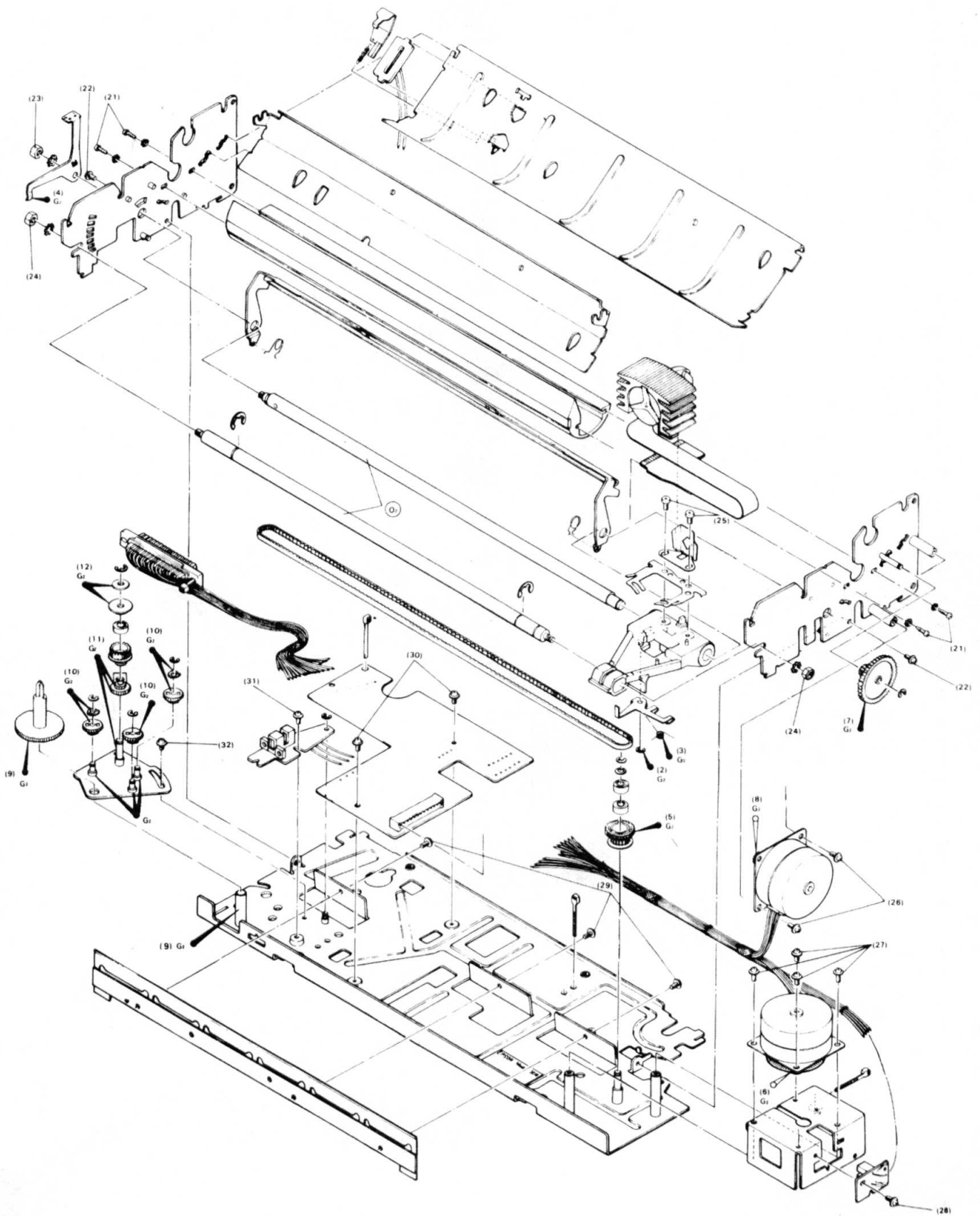
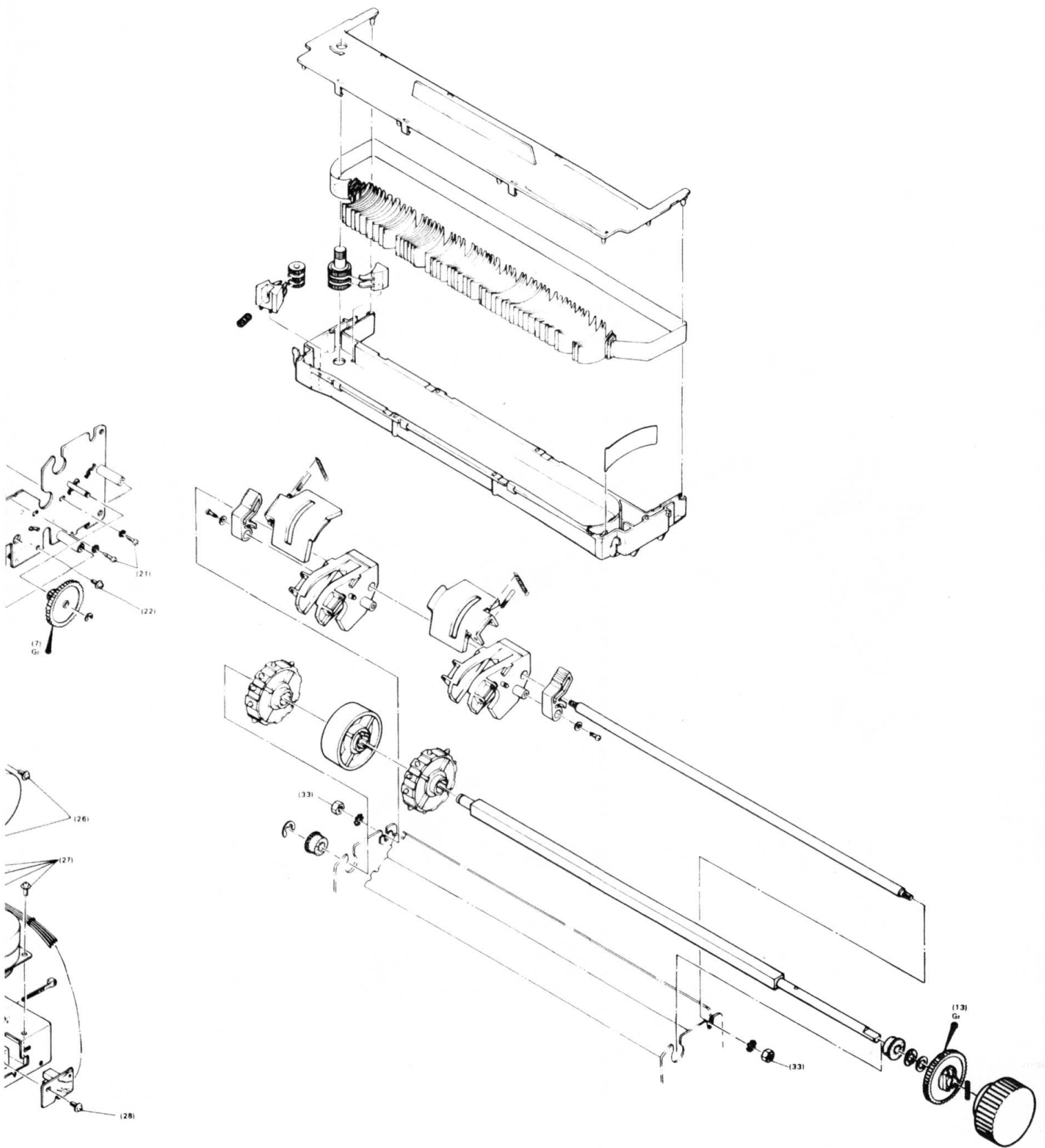

Fig. 4.1 Lube Points and Bone



I.1 Lube Points and Bonding Points

4.3 Adjustments

The MX-100 has some points requiring adjustments in its mechanisms and electric circuits. The methods of adjusting these points are described in this section.

4.3.1 Adjustment of head driving pulse width

The MX-100 is equipped with a high-performance, microminiature print head. To permit the constant generation of the proper printing energy in this print head, the pulse width for energizing the print head is controlled according to the change in the voltage applied to the print head solenoid. Fig. 4.2 shows the relationship between the voltage applied to the print head and head driving pulse width.

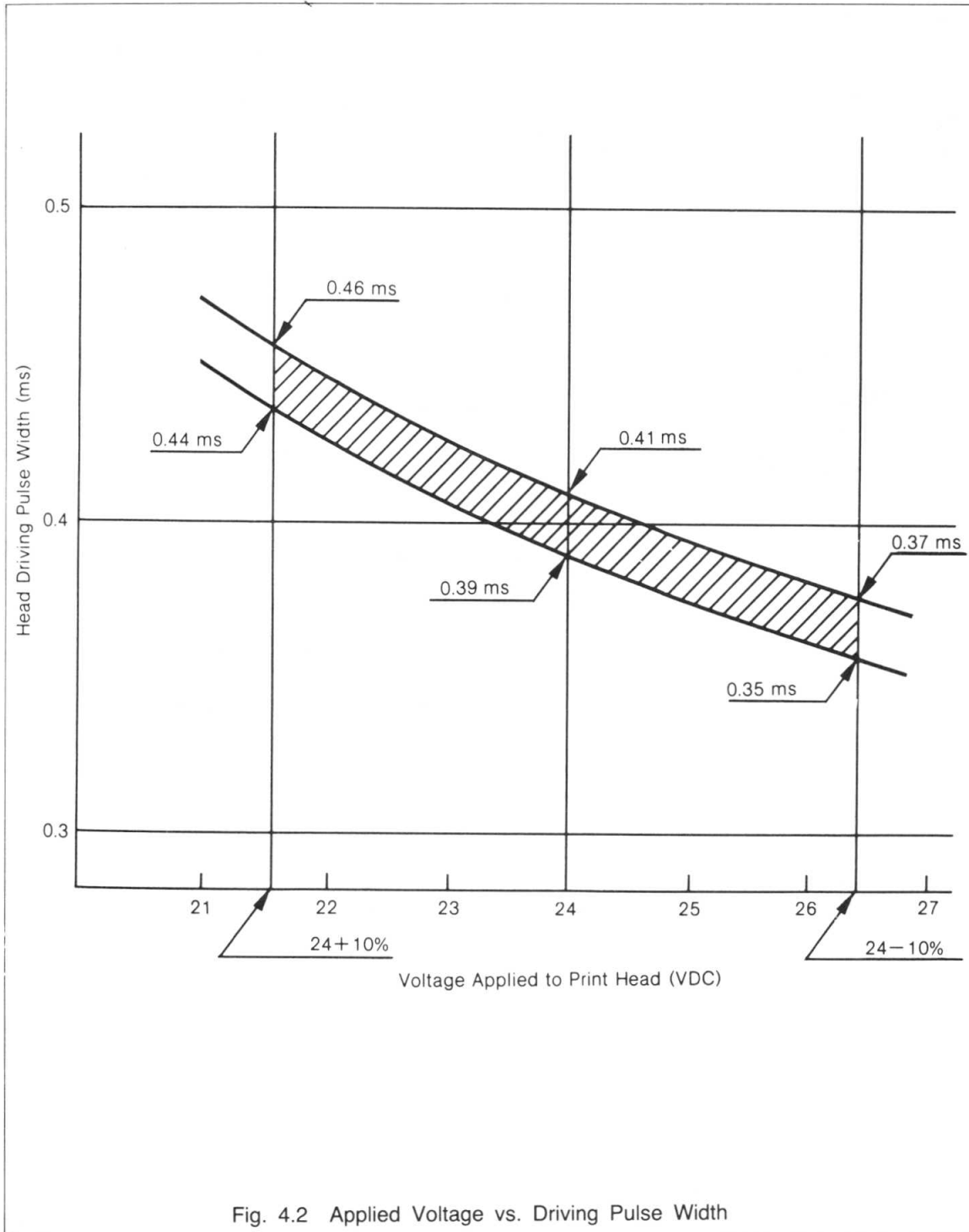

Fig. 4.2 Applied Voltage vs. Driving Pulse Width

The method of determining such a head driving pulse width as that assures the relationship shown in Fig. 4.2 is as follows.

- (1) Observe the pulse width at the terminal T0 of the driver circuit board with an oscilloscope.
NOTE: Before observing the pulse width, be sure to remove the print head.
- (2) Adjust variable resistor VR1 on the driver circuit board by turning it clockwise or counterclockwise so that the specified pulse widths are obtained at the respective voltages shown in Fig. 4.2, when observed with the oscilloscope.

NOTE: VR1 has been secured with adhesive (Neji Lock #2) prior to the shipment of the Printer from the factory. Before adjusting VR1, remove the adhesive with a knife. After the adjustment, be sure to apply Neji Lock #2.

4.3.2 Adjustment of timing pulse generating position

When the timing belt motor assembly or PTS sensor board assembly is replaced with a new one, the output position of timing signal PTS may deviate slightly from the original correct position. Since the MX-100 employs a new method for driving the timing belt motor, adjust the position of the PTS sensor as follows.

- (1) Shift the PTS sensor board to the right or left. (Refer to Fig. 4.3.)
- (2) Confirm that one pulse repetition period of the timing signal generated at the pin No. 39 of the 8049 becomes approx. 2.08 msec. (Refer to Fig. 4.4.)

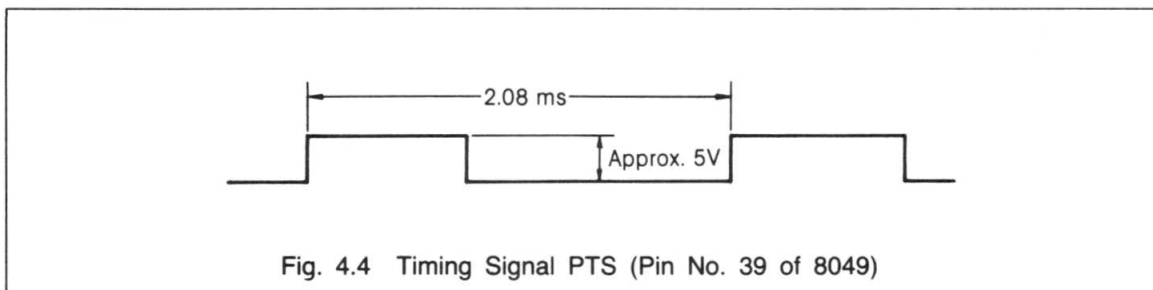
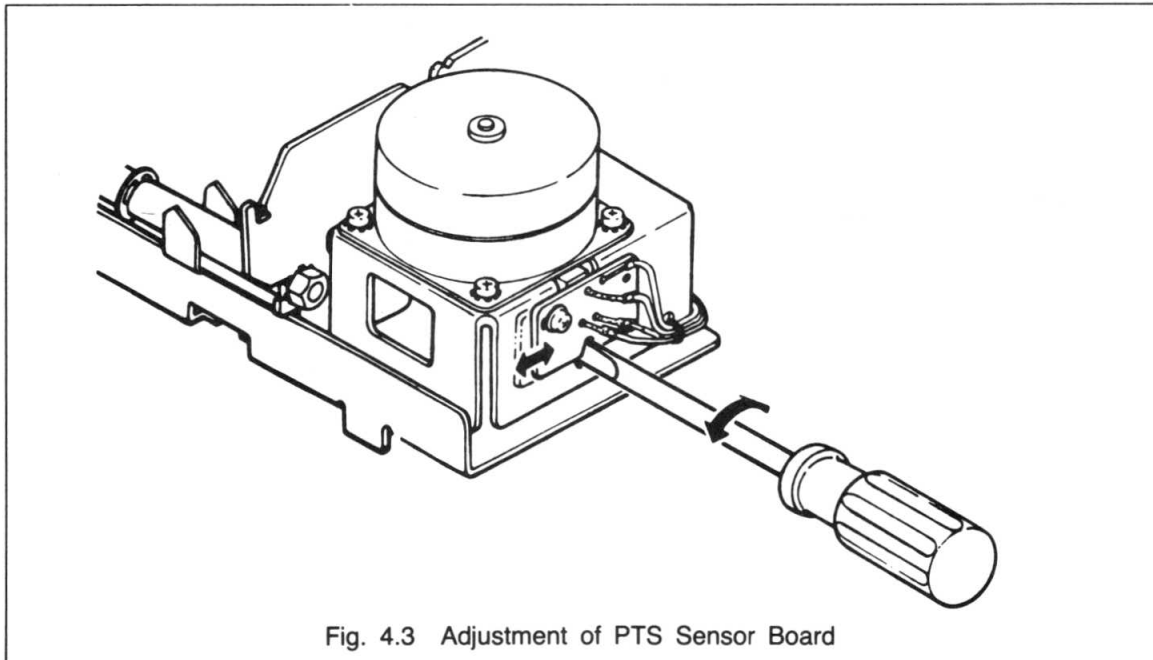

4.3.3 Adjustment of phase relationship between timing signal and reset signal

- (1) Shift the home position sensor assembly to the right or left. (Refer to Fig. 4.5.)
- (2) Confirm that the phase relationship between timing signal PTS and reset signal RS becomes as shown in Fig. 4.6.

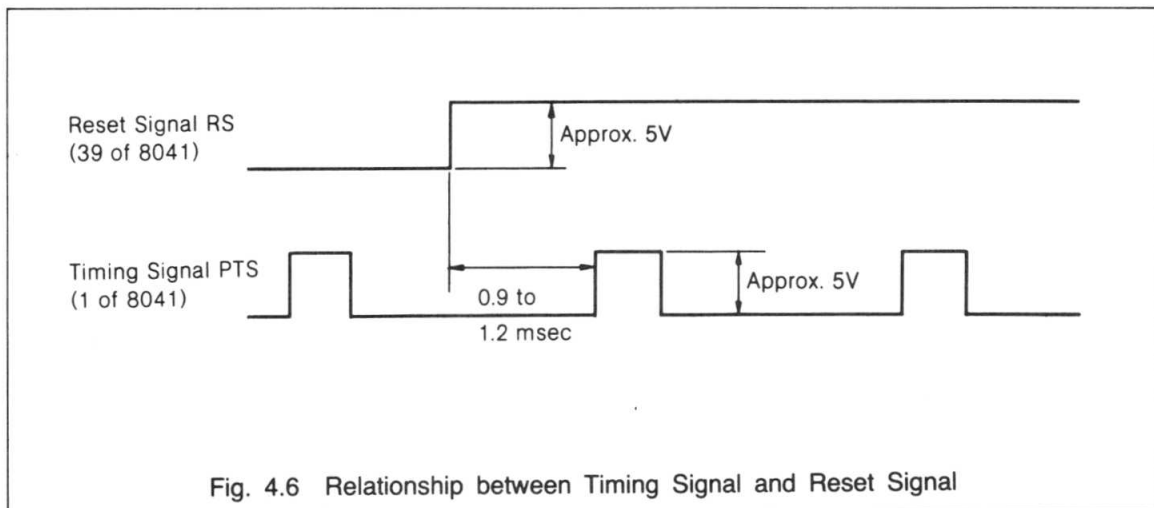
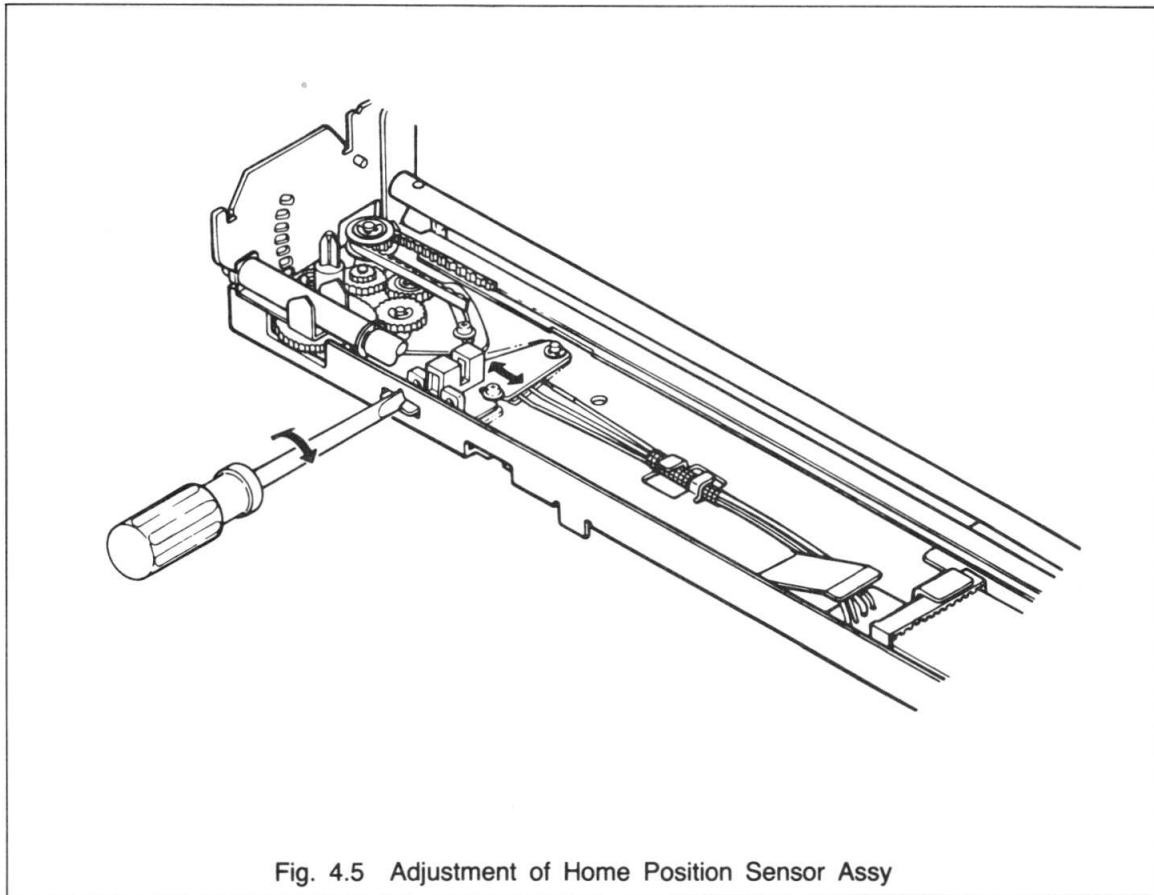

CHAPTER 5

CIRCUIT DIAGRAMS

CONTENTS

5.1 General	5-1
5.2 Connection Diagrams	5-2
5.3 Component Layout Drawings	5-5

5.1 General

This chapter contains the detailed connection diagrams of the control circuit and driver circuit in the MX-100 Dot Matrix Printer and the component layout drawings of the respective circuits.

5.2 Connection Diagrams

Fig. 5.1 shows the connection diagram of the control circuit board and Fig. 5.2, the connection diagram of the driver circuit board.

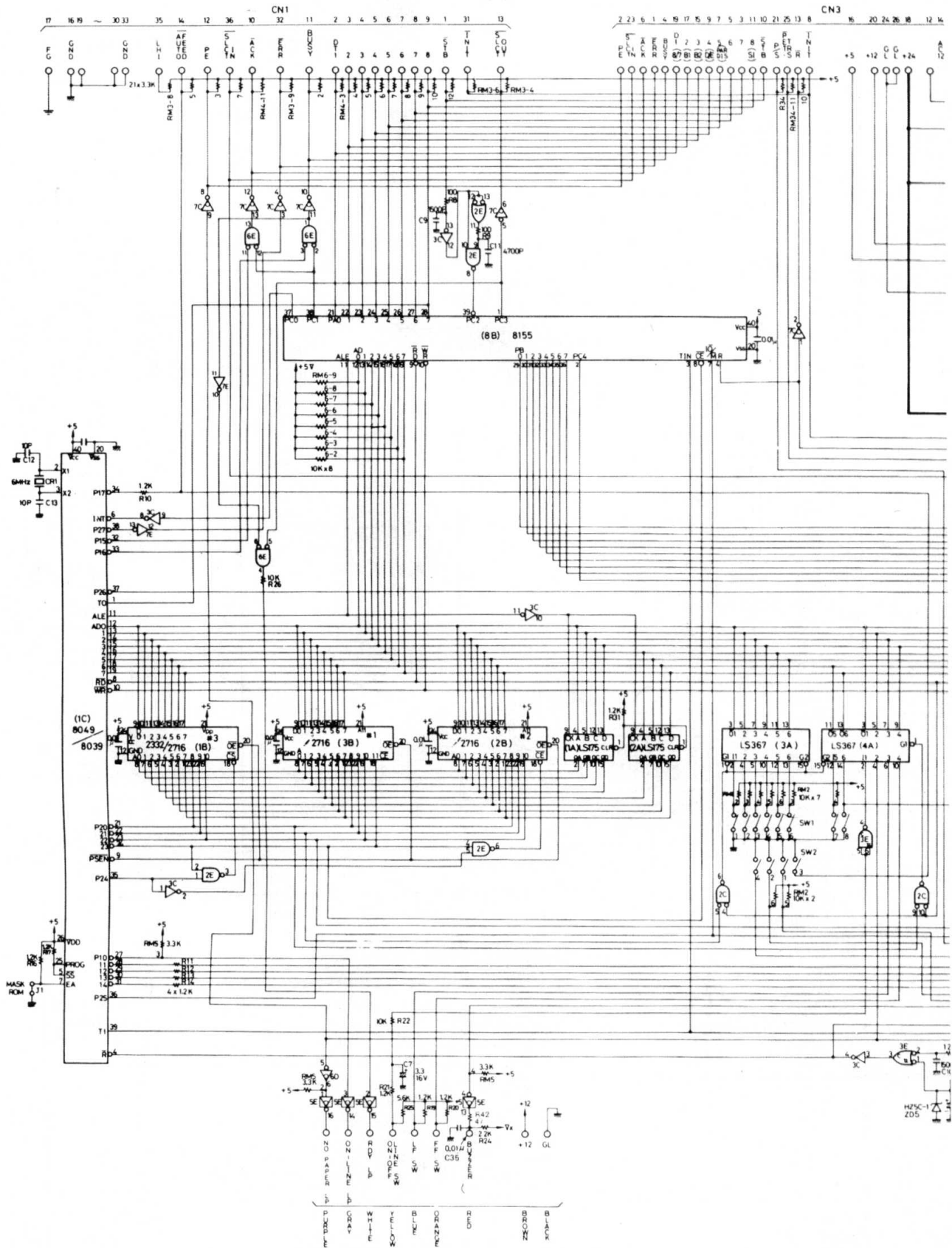

Fig. 5.1 Conn

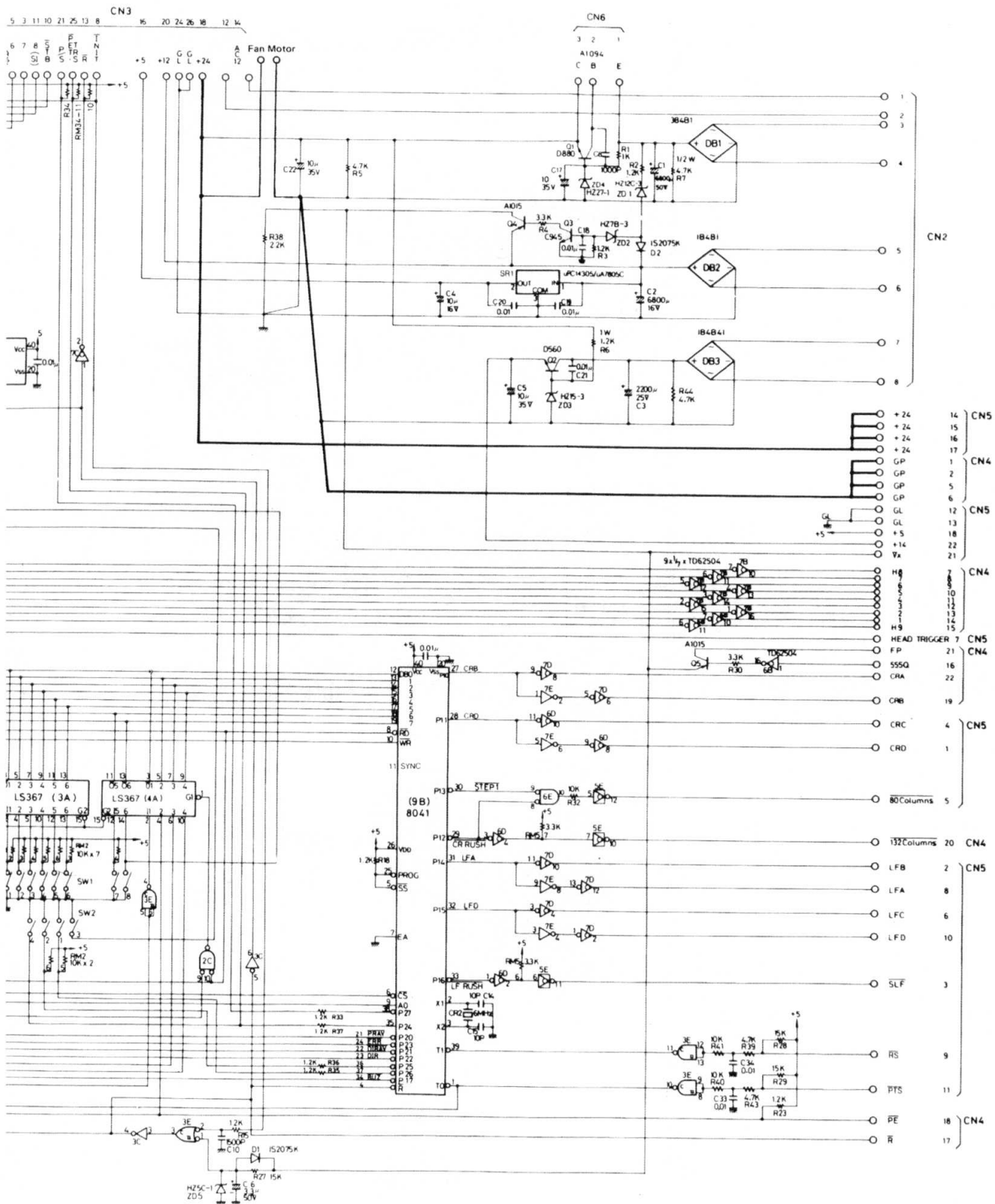
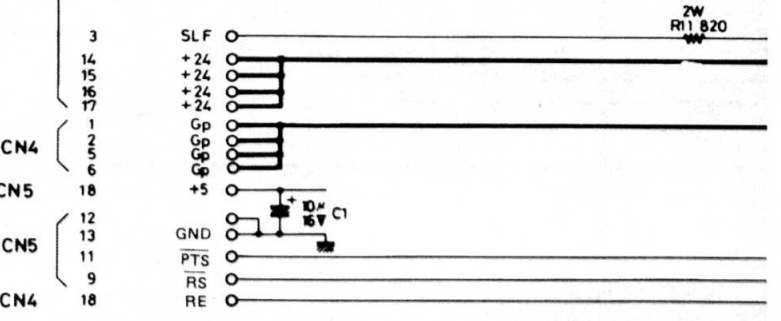
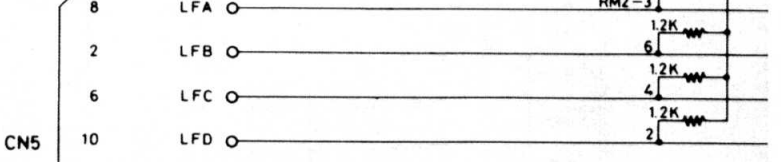
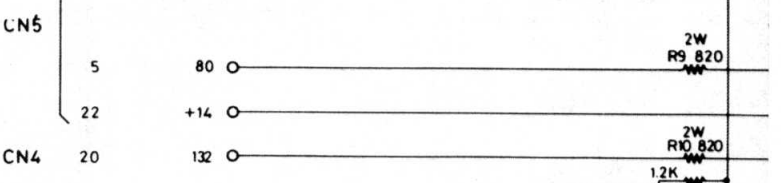
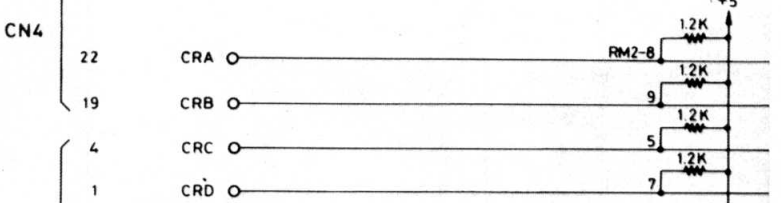
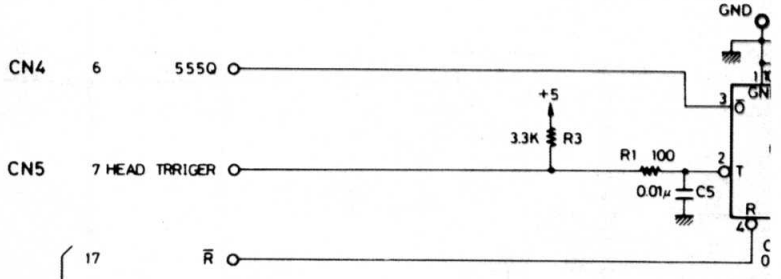
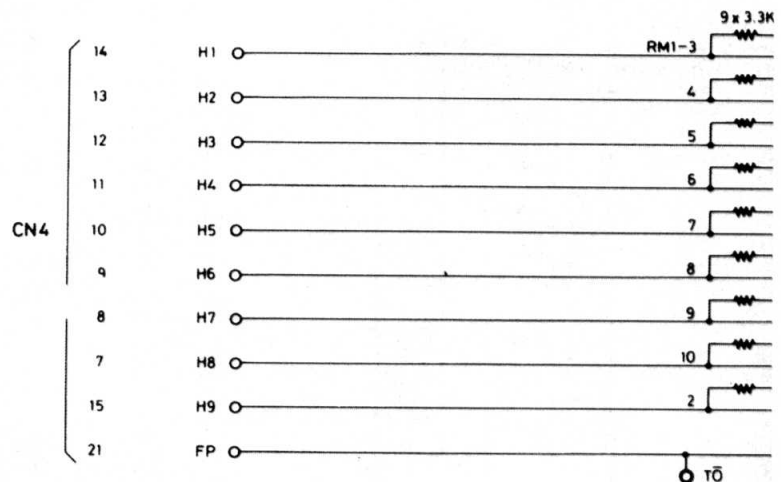

Fig. 5.1 Connection Diagram of Control Circuit



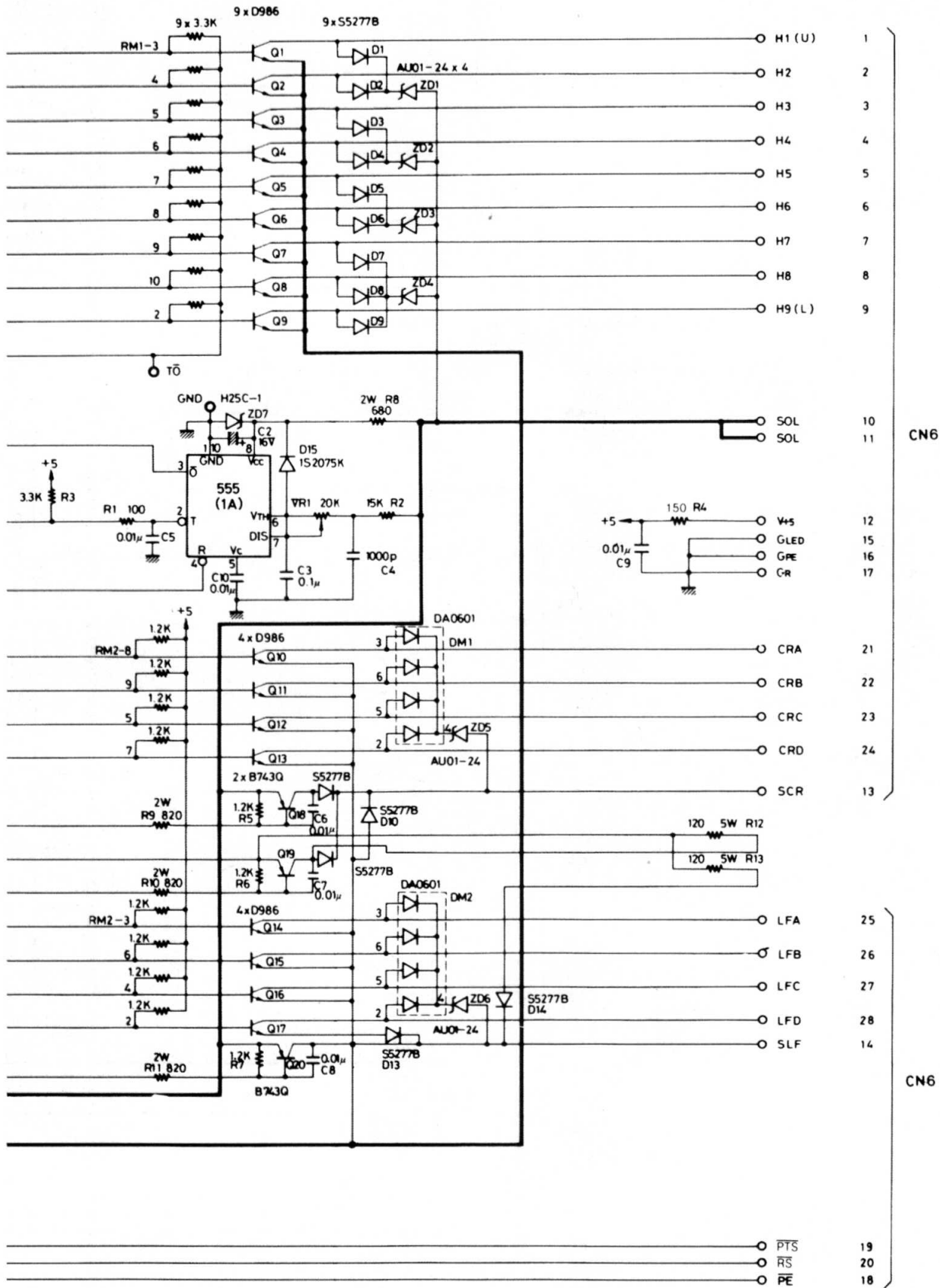

Fig. 5.2 Connection Diagram of Driver Circuit

5.3 Component Layout Drawings

Fig. 5.3 shows the component layout of the control circuit, and Fig. 5.4 the component layout of the driver circuit.

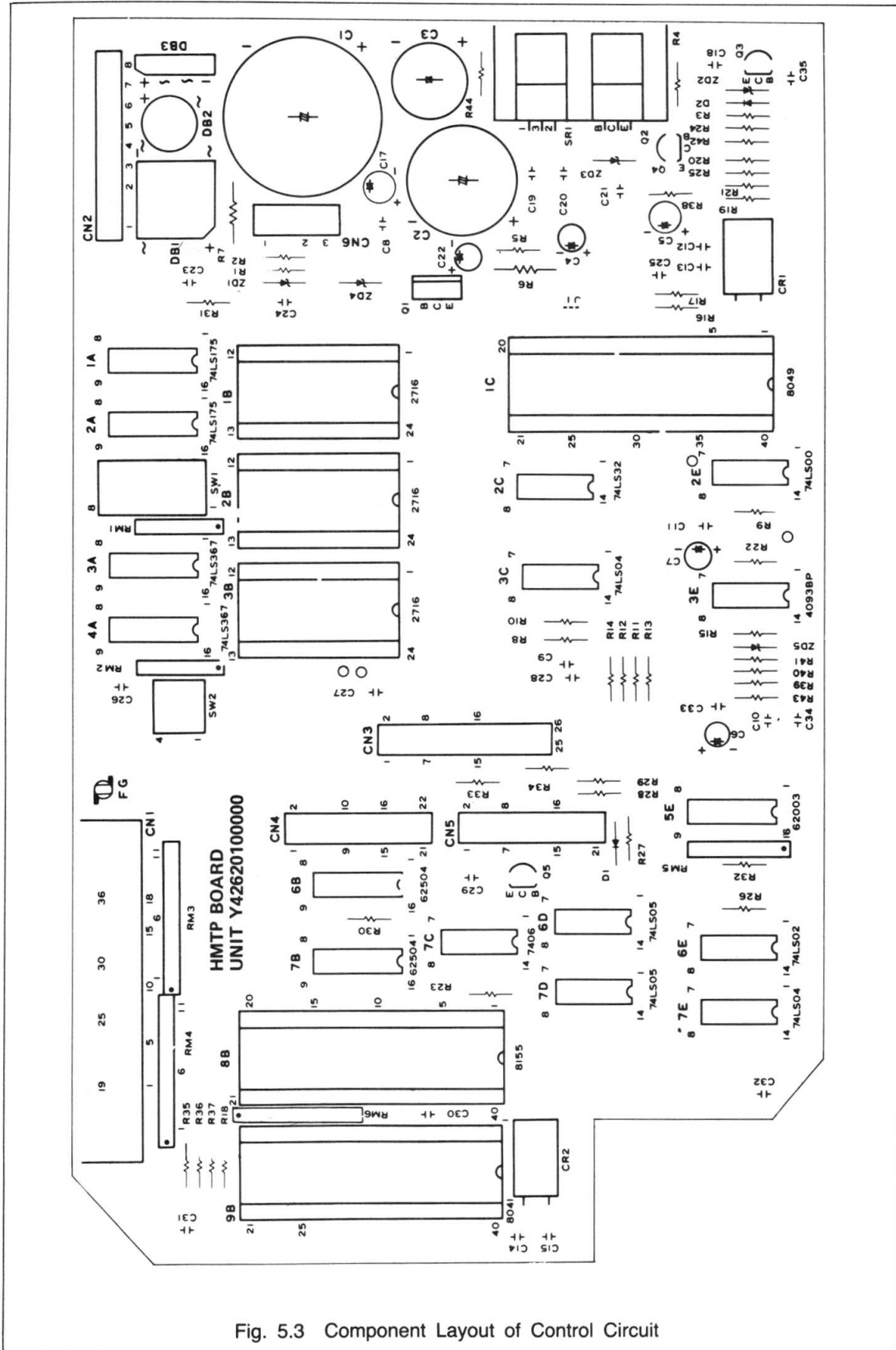

Fig. 5.3 Component Layout of Control Circuit

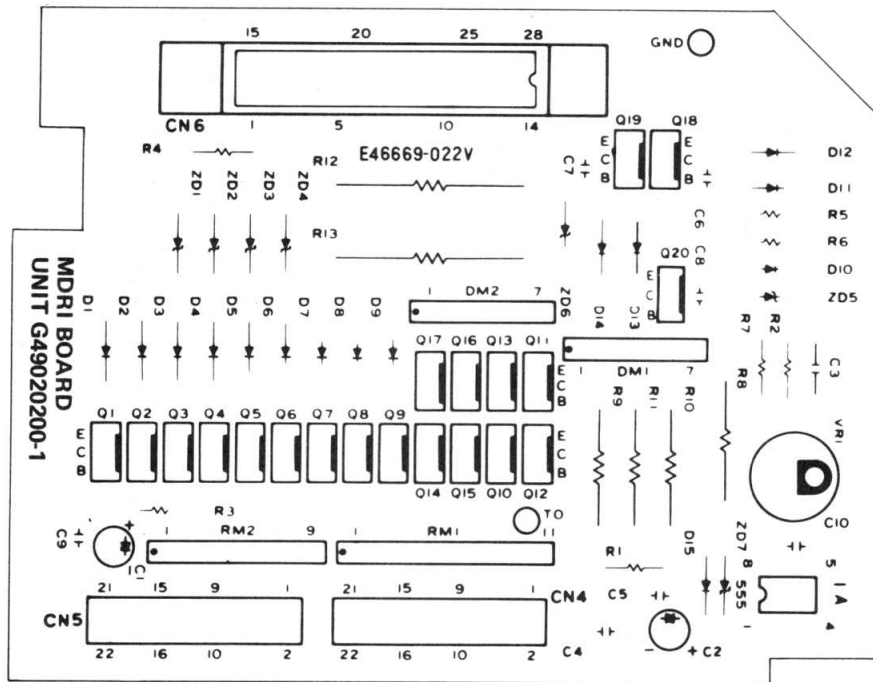

Fig. 5.4 Component Layout of Driver Circuit

CHAPTER 6

SIMPLE TROUBLESHOOTING

CONTENTS

6.1 General	6-1
6.2 Troubleshooting	6-1

6.1 General

This chapter covers the simple, quick troubleshooting procedures of the MX-100 to be followed by the operators who have only the fundamental knowledge of the construction and operating principle of the printer or by those who do not have sufficient tools and measuring instruments.

In a strict sense, it is considered advisable to conduct the troubleshooting of the MX-100 with some tools and measuring instruments prepared as the minimum requirements, by first locating causes of trouble and then replacing the defective components. Since the MX-100 can be simply disassembled into the electrical circuit block and the M-3360 printer mechanism block, a certain degree of trouble in the MX-100 can be solved by cut-and-try methods, namely, by presuming the troubled part and replacing it with a new component.

6.2 Troubleshooting

For troubleshooting the MX-100, it is first necessary to presume in which block of the printer the cause of trouble lies, the electric circuit block or M-3360 printer mechanism block. In troubleshooting without measuring instruments, this presumption must be made from the abnormal symptom presently existing in the Printer. The troubleshooting methods described in this chapter require no special measuring instruments but require the tools listed as class "A" in Table 3.1, Chapter 3 as the minimum requirements for repair. In addition, the troubleshooting methods are described on the basis of replacing only the components listed in Table 6.1. Replacement of other components cannot be made, as they require the adjustments of the MX-100 as described in Section 4.3, Chapter 4, or troubleshooting with measuring instruments such as oscilloscope, etc.

To replace any defective components listed in Table 6.1, be sure to observe the disassembly and assembly procedures described in Section 3.3, Chapter 3.

Table 6.1 Replaceable Components in Simple Troubleshooting

Block	Name of component
Electric circuit	* Driver circuit board * Control circuit board * Power transformer
Printer mechanism	* M-3360 mechanism * Print head unit

NOTE: Avoid touching other components, circuit elements or mechanical parts without use of required measuring instruments and tools, or the MX-100 may be damaged crucially.

SYMPTOM 3

The carriage assembly operates properly but characters are not printed correctly (i.e., omission of dots exists in the printed character).

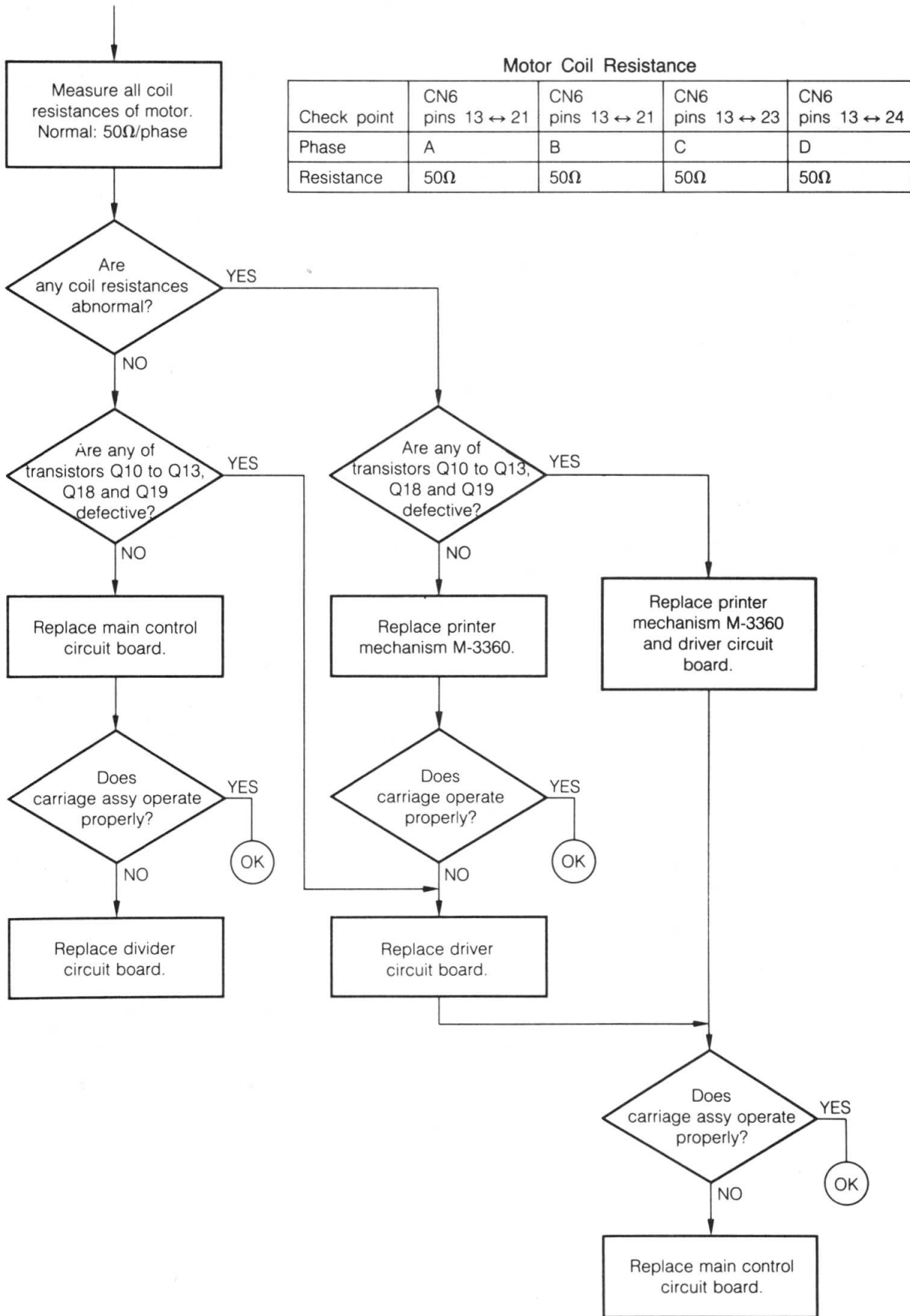

Motor Coil Resistance

Check point	CN6 pins 13 ↔ 21	CN6 pins 13 ↔ 21	CN6 pins 13 ↔ 23	CN6 pins 13 ↔ 24
Phase	A	B	C	D
Resistance	50Ω	50Ω	50Ω	50Ω

SYMPTOM 2

All the indicators on the control panel light but the carriage assembly does not operate.

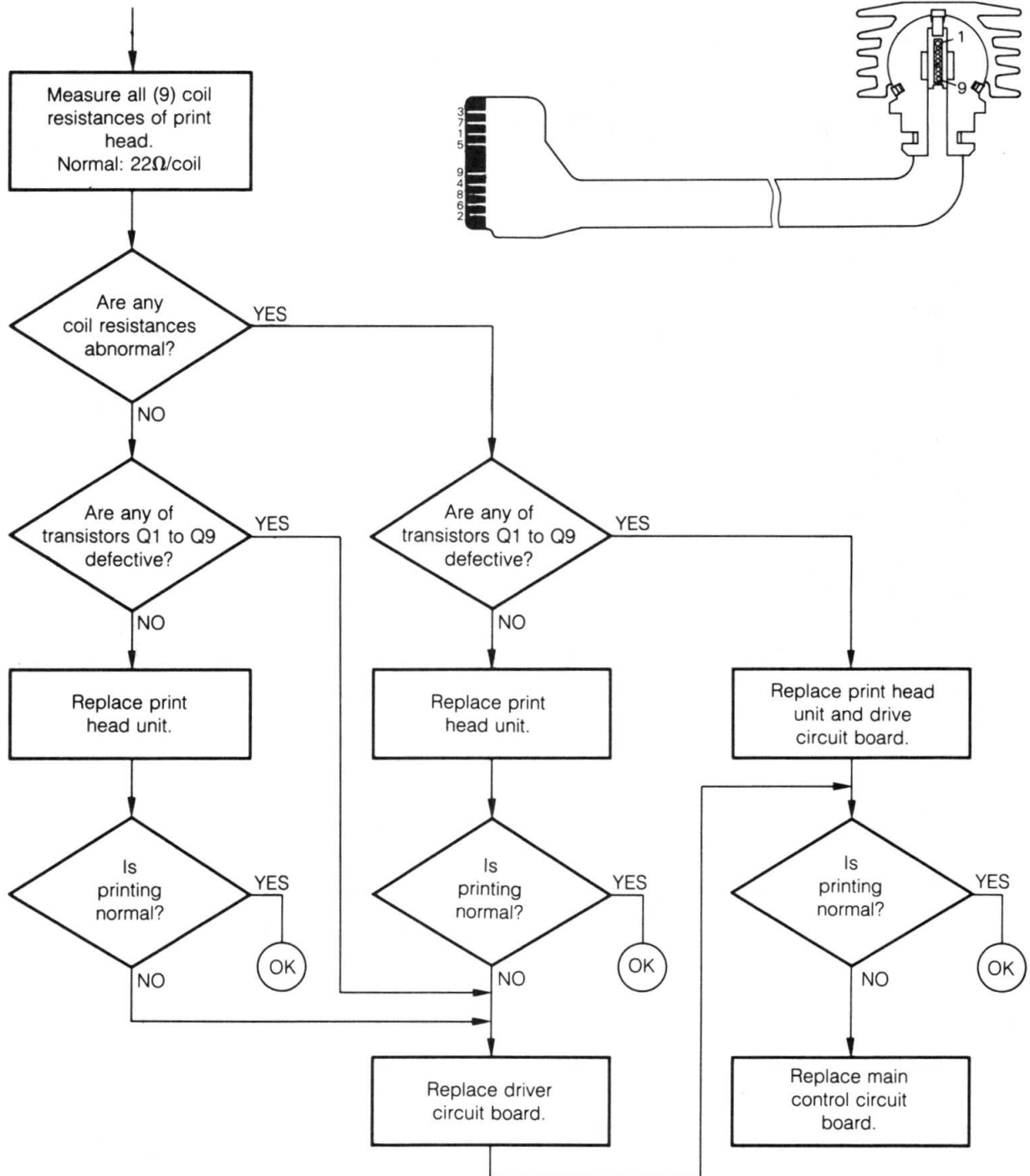

SYMPTOM 4
Paper is not fed at specified pitch or not fed at all.

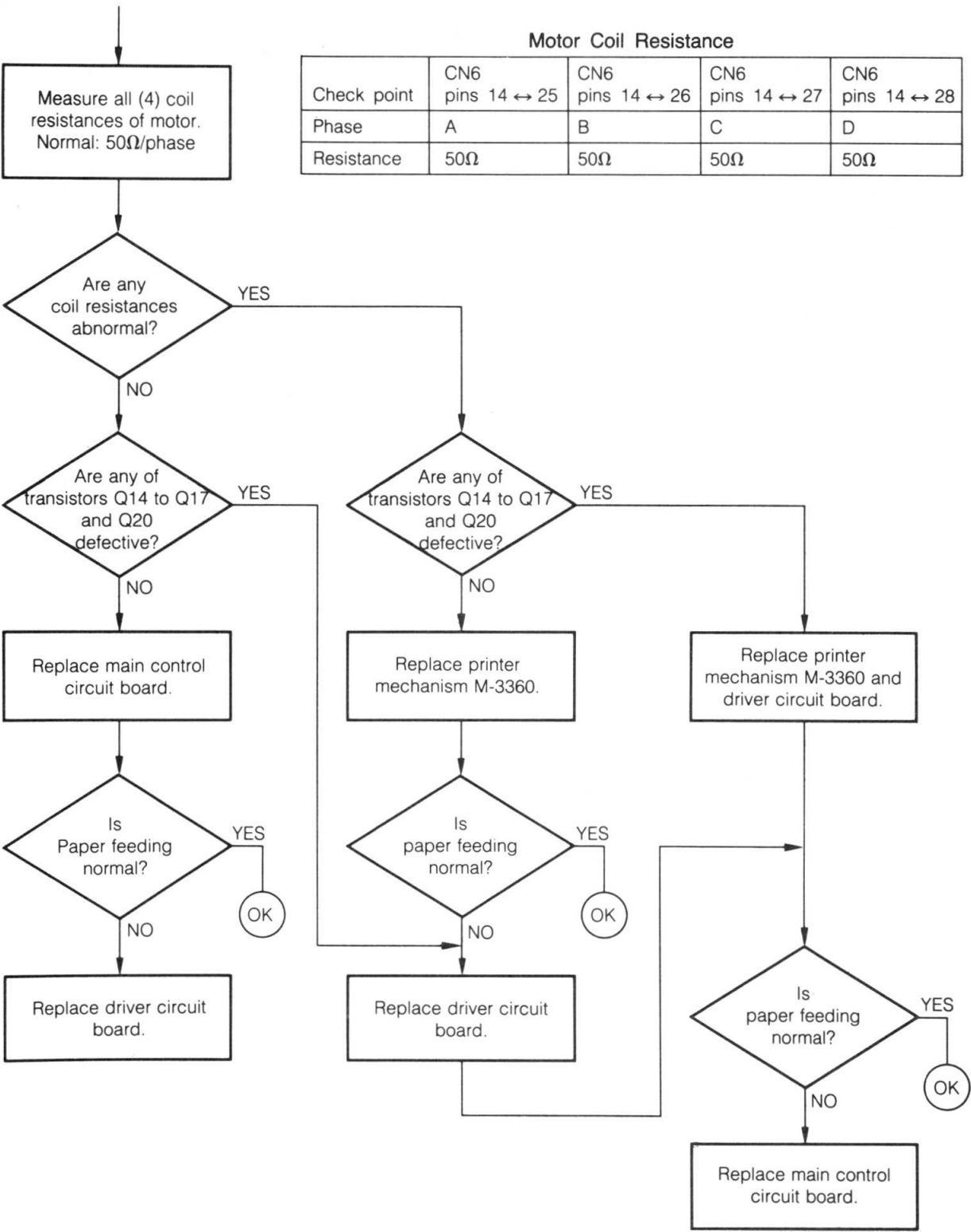

Motor Coil Resistance

Check point	CN6 pins 14 ↔ 25	CN6 pins 14 ↔ 26	CN6 pins 14 ↔ 27	CN6 pins 14 ↔ 28
Phase	A	B	C	D
Resistance	50Ω	50Ω	50Ω	50Ω

EPSON

SHINSHU SEIKI CO.,LTD.

EPSON OVERSEAS MARKETING LOCATIONS

EPSON AMERICA, INC. (L.A.)

3415 Kashiwa St.
Torrance, Calif., 90505
U.S.A.
Phone: (213) 539-9140
Telex: 182412

EPSON DEUTSCHLAND GmbH

Am Seestern 24
4000 Düsseldorf 11,
F.R. Germany
Phone: (0211) 596-1001
Telex: 8584786

EPSON U.K. LTD.

Sherwood House 176 Northolt Road
South Harrow
HA2 OEB U.K.
Phone: (01) 422-5612, (01) 422-1118
Telex: 8814169

