

# MODIFYING THE CASIOTONE INSTRUMENTS

The Casiotone M-10 and MT-30 are inexpensive, portable, battery operated musical instruments featuring eight note polyphony and 4 and 22 voices respectively. This technical bulletin gives you detailed instructions on how to greatly improve their musical possibilities by adding the following features :-

- |              |  |  |
|--------------|--|--|
| M-10 & MT-30 | Two octave drops<br>Variable tuning<br>Hold and sustain of notes | Different vibrato settings<br>Better high-frequency response |
| M-10 only    | Nineteen extra voices  | Lower noise and distortion                                   |

Suggestions are made on how to improve the larger Casiotone instruments - the CT-201, 202, 301 and 401. Most of the added features are already present in the LSI integrated circuit which forms the heart of each instrument, the VL-TONE however does not seem to have any hidden capabilities. The extra switches and components cost about \$15 for the MT-30 and \$25 for the M-10, and take about 5 and 10 hours to install. The person carrying out the modifications should have some experience in digital electronics. A circuit is described which allows any two Casiotone instruments (apart from the VL-TONE) to be coupled together as master and slave. Pressing a key on the master causes the slave to play that note as well, which means you have two completely independent voices. The coupler can also be used for computer interfacing of all the above instruments, but a VL-TONE can only be coupled to another VL-TONE.

This 14 page bulletin is available from Robin Whittle 42 Yeneda St Nth Balwyn 3104 Melbourne Australia for \$5 to cover printing and airmail. If you live outside Australia please send a bank draft on an Australian bank or US\$6 in American paper money because money orders and personal cheques from overseas are expensive and difficult to exchange.

This is a copy of a 1981 document. Addresses etc. are all out of date. For latest details, see <http://www.firstpr.com.au/rwl/casio/>



\*\*\*\* BACKGROUND \*\*\*\*

This technical bulletin replaces my previous bulletins 'How to get twenty-five voices from your Casiotone M-10' (December 1980) and 'Modifying the Casiotone M-10 and MT-30' (March 1981). This bulletin includes an edited copy of 'The Casiotone M-10, MT-30 and VL-TONE, the smallest computer instruments' a paper which I presented at the International Music and Technology Conference at Melbourne University in August 1981.

If you want more copies of this then use a photocopier, and if you want to charge money for modifying instruments using these instructions then be my guest, but if you want to sell or publish anything based on this work for financial reward then please do so with my prior consent. My objectives are primarily to distribute this information widely, and secondarily to cover my expenses. So far I have mailed over 60 of the earlier bulletins to people who read about them in several magazines, but I underestimated my costs and lost money. Since Casiotone instruments, and other instruments worth modifying will continue to pop up every few months for quite a long time, I can see that this bulletin will not be the last word. When further information comes to light, I will send everyone an update and ask for some money to cover its cost, those who respond will be on the mailing list for the next one. If you are not on my mailing list at present (you didn't get this bulletin directly from me) then write to me, and on it you will be put.

The first page of this bulletin is intended as a poster. Please make photocopies of it and display it wherever you think it will be seen by persons it is likely to interest, ie. music and electronic retailers and university music departments.

In this bulletin a detailed technical description of the Casiotone instruments is followed by modification instructions for the M-10 and for the MT-30. Modifications to the other instruments are discussed in theory at the end. DO NOT attack your instrument with a smouldering iron until you have read over the bulletin and the paper fully. If you have difficulty getting the required components, I will airmail them to you for AU\$40 and AU\$30 for the M-10 and MT-30 respectively. I have modified a number of instruments for other people but I would rather not do any more unless there is no alternative. The only exception would be if you live in a very remote area and don't have access to a Casiotone distributor or the technical expertise to do the mods.

If you have not yet purchased an instrument, and are wondering which one to get, then I would suggest the MT-30 as it is easier to modify fully. The M-10 is worthwhile buying even if you already have an MT-30, because it has many unique voices. Two instruments are better than one because they can be stacked closely and played together. If you intended on trekking in the Himalayas with your Casiotone, the smaller size of the M-10 would be a distinct advantage - in which case the M-10 would probably be your best first purchase.

I am 25, work as an electronic technician and in addition to my responsibilities as Chief Executive Officer of The Camberwell Cuddle Club, I am active in the making of music and the application of software control and digital synthesis to music. My achievements so far are these modification notes and a Z-80 disk based software controlled rhythm system in which analog and digital 'percussive' sounds are arranged interactively as characters on the VDU screen. Maybe one day you will hear it jumping out of your radio as part of my music or that of Equal Local, the band I was a member of. My current project is to complete a Big Board based computer for Equal Local. Then I will build a similar system for myself, write a new rhythm program for them both, build a mixing and patching system for home recording and a digital signal processor with 128k of 16 bit RAM. Meanwhile I hope to play music, have an active social life and hold down a job.

I wrote to Mr Noriaki Shimura, the managing director of Casio to tell him what I have been doing and to convince him of the wide demand for really flexible instruments. Although I have not received a reply yet - I have heard that they (some members of Casio management I presume) were impressed, and would like to meet me when they visit Australia later in 1981.

Two people who wrote to me have already done extensive mods to musical instruments:- Thomas G. Schneider has fully interfaced his MT-30 to his Apple computer, and D.J. Perkins has modified a Yamaha CH 70 piano/organ to make use of extra functions in the LSI chip. If you have similar knowledge likely to be of interest to others please let me know so that I can disseminate it to interested persons. More importantly write to Craig Anderton the editor of 'Polyphony' a magazine which specialises in modifications to musical instruments. Mike Beecher of 'Electronics and Music Maker' would probably also be interested as well. If you are interested in Computer Music then you will almost certainly want to subscribe to 'Computer Music Journal' and perhaps join the Computer Music Association and receive its quarterly newsletter.

Polyphony - 6 issues per year \$8 US/\$10 foreign. Box W20305  
Oklahoma City, OK 73156 USA

Electronics and Music Maker - 12 issues Airmail 25.20 Pounds  
282 London Road Westcliff-on-Sea Essex SS0 7JG  
ENGLAND

Computer Music Journal - Editor Curtis B.Roads. Four issues  
per year \$30 US - \$40 Airmail anywhere else. MIT  
Press Journals Dept. 28 Carleton St. Cambridge  
Massachusetts 02142 USA

Computer Music Association - PO box 1634 San Francisco CA  
94101 USA Membership is \$6 per year, but if you live  
outside the US I suggest sending more because it  
costs them \$1.32 to airmail each newsletter to  
Australia.

Casio Computer Company Ltd. - Shinjuku Sumitomo Bldg. 6-1  
Nishu-Shinjuku 2-chome, Shijuku-ku. Tokyo Japan

Thomas G.Schneider - 1101 Ocean Front Walk #14 Venice CA  
90291 USA

D.J.Perkins - 31 Bone St Morphett Vale SA 5162 Australia

\*\*\*\* HOW THE INSTRUMENTS WORK \*\*\*\*

See the accompanying paper for a general discussion of the inner workings. Since the VL-TONE apparently has no hidden features and the only modifications I can suggest are bypassing the filter and rounding off the keys, I will concentrate the following discussion on the remaining polyphonic instruments. My information is derived from direct experience with the M-10 and MT-30 and from circuit diagrams of the M-10, CT-201 and CT-301. There are four major areas of interest to us:-

- 1/ Clock Circuit - Drives the LSI through its paces.
- 2/ LSI - (Large Scale Integration) Virtually everything happens on this remarkable piece of silicon.
- 3/ Switch array - All keys and switches are connected with diodes to form an 8 by 9 array which is scanned by the LSI.
- 4/ DAC and Filter - Digital to Analog Converter turns the digital output of the LSI into a voltage which is the sound. The low-pass filter cuts off the higher frequencies.

\*\* CLOCK CIRCUIT \*\*

The M-10 uses a 4.536688 MHz crystal oscillator, which is divided by four and fed into pin 37 of the LSI, where it is divided by two to form the internal 567.086 KHz internal clock. The CT-201 divides the crystal oscillator by eight and drives pin 35 of the two LSIs, which are reset together and so always remain in step. While the CT-201(B) feeds 1134.172 KHz into pin 37 of the 771 (see below) and uses its pin 35 to drive pin 35 of the 772. The CT-301 uses an adjustable oscillator and a phase-lock-loop (for delayed vibrato) and drives pin 35 while the MT-30 uses a variable inductor tuned oscillator and drives pin 37. The CT-202 is tunable so it probably uses a similar oscillator to the CT-301: an inductor and vari-cap diode controlled by a pot on the back panel.

**\*\* LSI \*\***

The CT-201 uses a uPd771 and uPd772, the M-10 and CT-301 use a uPd773 and the MT-30 uses a uPd775 LSI. The CT-301 gives the user access to 14 of the 23 possible voices of the 773 while the M-10 user only gets four. Although I have only worked on the 773 and 775, I think it is safe to assume that the others, including the two in the CT-202 have very similar attributes. The functions of the pins are:-

Pins 1 - 12	Liquid Crystal Display segment drivers.
Pins 13, 14	LCD common drivers.
Pin 15	Reset active low.
Pins 16 - 24	Switch Sensing inputs.
Pins 25-31+33	Key Commons #8 to #1. These drive the switch array.
Pin 32	Ground.
Pin 34	'I2' Normally grounded, but CT-301 drives it hi when tone select button is pressed.
Pin 35	567.086 KHz Clock input.
Pin 36	Unknown.
Pin 37	1134.172 KHz Clock input.
Pin 38	Clock input select Low = Pin 37.
Pin 39	'IO-1' Output goes low while voice is being changed - used to mute the audio output.
Pins 40 - 47	0-29 to 0-31 and IO-4 to IO-8, used for filter, volume and LED control in different ways. Pin 46 controls filter cutoff frequency in the M-10.
Pins 48 - 61	0-28 to 0-15. Fourteen bits of digital audio.
Pins 62, 63	+VG, +VD, power supply.
Pin 64	VDS1, 'LCD voltage 3.1V input, not used'

**\*\* SWITCH ARRAY \*\***

It is most important that you understand how the switch sensing system works before you carry out any modifications. First of all Key Common #1 goes to ground while all the others stay at 5 volts. If for instance the top C key is pressed then KC1 is connected to one of the Key Sense pins via a diode, and so that Sense pin is pulled low and the LSI detects that you have pressed the key. Next KC1 goes hi, KC2 goes low and the LSI checks the 9 sense pins to see which ones are low and therefore which switches have been closed. This is repeated for the remaining 6 common pins and so the LSI looks for a total of  $8 \times 9 = 72$  possible switches. I use the term 'Switch Position' to denote the possibility of a switch being connected between a Common pin and a Sense pin, rather than the actual existence of such a switch. When I first modified the M-10 I gave my own numbers to the Sense pins which were different from the official Casio designation as shown in Table 1. As Grand Poobar of Casiotone Modification World Headquarters I have decided to persevere with my System. Note that every switch must be in series with a diode or else it will interfere with other switches - for instance to control switch position 6-1, connect a switch and diode between pins 27 and 16 with the cathode towards pin 27.

Table 3 lists the 72 switch positions of the uPd77x chips, with the voices of the uPd773 shown in the second last column. 48 of the 49 notes of the four octave keyboard are arranged in an orderly fashion using six sense lines - 4 to 9 inclusive. The exception is the lowest C (C1) which is 1 3 or 2 3. The switch positions using Sense 3 are somewhat anomalous, and only 1 3 is normally used. Closing 1 3 will cause a C1 to be played, and simultaneously closing 2 3 will cause another C1 note to play - in another sound channel. Succeeding pairs 3 3 & 4 3, 5 3 & 6 3, 7 3 & 8 3 play C2, C3 and C4 respectively. 3 3, 4 3, 7 3 and 8 3 however behave in very strange ways when octave drop (8 1) is closed, the sound they make changes pitch as you play, and is affected by the vibrato and tone memory positions.

**\* VOICES \***

Voices are selected by closing the 'Set' switch position (3 1 or 3 2) and simultaneously pressing a key. The CT-201/2 and MT-30 are equipped with a four position 'Tone Memory' switch and a 'Set' switch. Every key of the CT-202 identifies a voice, and so is appropriately labelled - 'Harpiscord 2', 'Fluegelhorn' etc. If the 'Tone Memory' is in position 2 and you close the 'Set' switch and press a key, then the voice identified by that key is loaded into Tone Memory 2, and an A note is played with that voice so that you know what it sounds like. If for instance you pressed E above middle C then 'Taisho Koto' would be put into Tone Memory 2. If you wanted something more occidental you could then press the lowest F, which would load 'Funky Clavi' into Tone Memory 2. Happy with your selection of

voice (Casio call them sounds or tones) you then move the Set switch from Set to its normal position 'Play' (which means that 3 1 is no longer closed) and can play some music using the 'Funky Clavi' voice. Moving the Tone Memory switch to 3 allows you to play or change the voice stored therein. At no time can voices be mixed. The MT-30 differs in that only the white keys have voices, and that the switch positions for the lowest octave (which cannot be played on the 3 octave keyboard) select only voices which you already have access to.

The uPd773 LSI, which is used in the CT-301, CT-401 and M-10 is capable of 23 voices, but users of these instruments are not given full access to them. The M-10 has a Tone Memory switch, but no Set switch, so in an unmodified instrument it is impossible to load different voices into it. The other two have no Tone Memory switch, or Set switch as such, but the 14 voice buttons are connected with a few logic gates to the LSI, so that for instance, pressing the 'Oboe' button causes the 3 1 and 8 9 switch positions to be closed. Looking at Table 2 you will see that these are the 'Set' and B4 (Top B) functions. Simply adding a push button switch and a diode to the CT-301 or CT-401 will allow you to select any of the 23 voices by simultaneously pressing the switch and the appropriate key. Since the M-10's keyboard starts at F2 we have to go to quite a lot of trouble to select the voices identified by the keys that the M-10 does not have.

If you try to select a voice using a key which does not identify a voice, then a silent 'Null' voice will be loaded into that Tone Memory position. Pressing two keys at once will still only give you one of the voices. The anomalous Key switch positions 1 3 to 8 3 when closed in conjunction with the Set switch will select a voice (Flute for the uPd773). What I call the 'Funny Function' switch on the M-10, controls switch position 7 3 or 8 3. This allows you to have a drone which changes pitch and timbre as you play, or stays at C3, and allows you to select the flute voice of the M-10.

Looking closely at the uPd773 voices I have concluded that my original claim of 'Get 25 voices from your M-10' was a little over the mark. The CT-301's 'ELEC.PIANO' voice is the same wave form as the 'PIANO' and the M-10's 'Piano', although the filter is controlled differently for each one, and so there are really 19 new, or a total of 23 unique voices. The CT-301's 'ORGAN' is a louder version of the M-10's 'Organ' and so does not count as a new voice. 'Mystery 1' and 'Mystery 2' are similar, but not identical to 'St. Ensemble' and 'Trumpet' voices of the MT-30. The 'VIOLIN' and 'Thin Violin' voices have a delayed release envelope when the Sustain switch is on - the volume remains constant for a fraction of a second after the key is released, and takes a similar time to decay. The voices of the other chips are already apparent to owners of the CT-201, CT-202 and MT-30.

Although I have not conducted detailed tests on the tuning of the Casiotone instruments, I have found that switch position 2 1 affects it slightly. The instrument's range can be seen as five octaves, two above middle C and three below, with the four octave keyboard switched down one octave when 8 1 is closed. The top octave of pitches are slightly detuned from the octave above middle C, and the three octaves below are slightly detuned from each other and from the middle C octave. When 2 1 is closed these lower octaves line up exactly with the middle C octave. It is hard to say why this feature was built in - Casio do not seem to use it, but it may be useful when playing two instruments together to have them tuned slightly differently.

**\*\* DAC AND FILTER \*\***

The original CT-201 used expensive 14 bit hybrid DACs, while the CT-201b used 12 bit discrete DACs with an adjustable Most Significant Bit (MSB). The two signals are extensively filtered before being mixed for the single output. The M-10 uses a 12 bit discrete non adjustable DAC, and a low pass filter with two possible cutoff frequencies - both rather low. The CT-301 uses a 12 bit hybrid DAC and a filter block with four possible cutoff frequencies or flat response. The MT-30 uses a 14 bit adjustable discrete DAC, and a filter similar to that in the M-10. It is quite likely that the CT-401 closely resembles the CT-301, and likewise the CT-202 the later CT-201. I have listened to the CT-202 and by the way the sounds end, I would say that they do use 12 bit DACs. I have just converted my M-10 to 14 bits with an adjustable MSB and the improvement in sound is quite marked. If all the above is true, then apart from the early

CT-201 and the MT-30, all the Casiotone instruments would benefit from a bit of work on the DACs. See the last section of the M-10 modifications for further details.

\*\*\*\* MODIFYING THE INSTRUMENTS \*\*\*\*  
\*\*\* GENERAL \*\*\*

Here I will discuss a number of considerations common to all the instruments. There is a danger of damaging the LSI chip with static electricity when working on them. Precautions include earthing your soldering iron, yourself and the ground rail of your instrument, and not wearing plastic soled shoes. I don't know how big a problem this is but I hope no-one has to find out by zapping their LSI and therefore their instrument. All the switches you install MUST have their chassis connected to the ground rail of the instrument, otherwise sooner or later your cat will discover how to turn on you Casiotone, stroll up and down the manual to the tune of an imperfect arpeggio and develop a potential difference between its furry self and the plastic instrument well in excess of ten thousand volts....all very well until.....SUDDENLY! in a flash of feline inspiration, your cat goes to set the software octave drop, a spark travels from its highly conductive nose to the chassis of the switch and from there to a wire leading directly to the LSI. Within microseconds it is all over - a fraction of a micron of silicon dioxide is vaporised, a solitary MOSFET comes to a grizzly end, and your instrument will not work properly ever again.

The toggle-switches I used originally were Japanese sub-miniature ones which were very good. Supplies ran out and I used Taiwanese switches which were an abomination - they melt when you solder to them. I now use and recommend 'C&K Tiny Toggles' T101 and T201 (double pole) which are very nice switches indeed. The push-buttons are C&K 8121 or 8125 which click in a most satisfying manner, and have pretty colored buttons. They are mounted on 1 cm centres, and have the earthing wire looped through the spring washer, which goes between the switch and the inside of the instrument case. Switches are off in the left position. For the 'Pedal sustain' footswitch I use a push-button mounted in a little white 'Vero' box with a shielded wire and 3.5 mm miniplug. The circuitry this connects to is well protected against static so no precautions are necessary. All the wiring inside the instrument is done with wire-wrap wire, although very thin 'telephone' wire would be OK. Exercise caution when stripping this fine wire so as not to weaken it.

\*\*\* DISMANTLING \*\*\*

Prise off the knobs using a strong smooth-bladed dinner knife, taking note of the different size holes for switches and sliders. Remove the screws from the bottom of the instrument - 4 for the M-10, 8 for the MT-30 including two in the battery compartment. Replace the batteries. Hold the instrument with its front facing towards you and assuming you are right-handed, use your left hand to bend the two halves of the case apart. Your enemy is the first clip which is situated under the lowest G for the M-10 or F for the MT-30, use the dinner knife to persuade it while keeping up strong pressure with your left hand. Repeat the process along the front and then the back of the instrument. For the MT-30, remove 2 screws on the PC board and 6 on the steel frame and attach the black wire to the frame with the screw on the right of the volume pot. For the M-10:-

- 1/ At the left end of the battery compartment is an exposed battery contact with 7.5 volts on it. Put some insulation tape over it so it can't touch anything.
- 2/ Undo the two small Phillips head screws that attach the switch panel (vibrato, voice, volume) to the bottom part of the case. This leaves two lugs loose, undo the left screw that holds the vibrato switch on and clamp them under that.
- 3/ Undo the four screws that hold the key board frame onto the case and undo the two screws holding the switch panel to the keyboard frame.
- 4/ Lift up the keyboard and turn it over onto something soft so you can remove the 5 screws holding the circuit board to the keyboard frame. Lift the circuit board towards you. On each side of the keyboard frame there is a protruding piece of steel 9 mm square with a 4 mm hole in it, remove these tabs because they get in the way of the switches to

be installed later. Also cut off the plastic pins on the bottom case which go through these holes. Take out one of the little grey plastic cups from the keyboard and store the keyboard so that dust will not get on the conductive rubber contacts.

- 5/ Put the circuit board down in the case again and verify that your Casio still works using the contact cup you just removed from the keyboard.

\*\*\* M-10 MODIFICATIONS \*\*\*

The M-10 is harder to modify than the MT-30 because there are more changes to make and less room to make them in, however I can assure you that the increased musical possibilities are well worth the claustrophobia. The accompanying paper lists the extra features you can add to the M-10, with the relevant switches starting from the top on the left of the keyboard and working down and then likewise on the right. Read the 'Further Modification' section, and experiment with the switch positions using wires and diodes before you decide which features you want and therefore how many holes you are going to drill. For instance you may decide that the normal vibrato is woeful and therefore of no musical value to you, in which case you can modify the existing vibrato switch to be the mild vibrato, and save yourself a switch. The 'Funny Function' - switch position 7 3 or 8 3 as previously described in the Switch Matrix section - can be omitted if it does not appeal to you. The tuning mod is quite tricky to do, and is useful but not essential. There is no real need to be able to switch between crystal and variable tuning so you can omit the switch and have it permanently variable. The modifications to the DAC are not essential, but well worthwhile.

\*\* VIBRATO \*\*

The vibrato switch normally is connected to switch position 6 1, this mod connects it to 6 2 which is a milder vibrato. Between keypads 23 and 26 (on the foil side of the board) is where we are going to work, refer to Fig. 1a at the end of this blurb. Cut the traces at A and B and add jumpers between C and D, and E and F, so the result looks like Fig. 1b. Alternatively you may add a separate switch for mild vibrato and in either case you will want a vibrato speed drop switch - 7 1. Rather than attaching wires directly to the LSI pins I advise following the PC tracks emanating from the pin you want and connecting to one of them, either by poking your wire through a nearby hole and scraping away the green solder resist, or by soldering to the lead of a component that is connected to that track.

\*\* SOFTWARE OCTAVE DROP, HOLD AND SUSTAIN \*\*

These are three toggle switches on the right side of the keyboard in my instrument, the hardware octave drop and tone switch are described later. The circuit we want to construct is shown in Fig. 2, I mounted the diodes on the switches and made the wires to the switches about 8 inches long. The connections to the M-10 were all made on the component side of the board in the following way:-

S1 and S2: Solder to the anode leads of the diodes which goes to the pads labelled E and F in Fig. 1a, or D and F if you have modified the vibrato switch as described above.

C8: Solder to the jumper wire labelled J-1B between keypads 29 and 30.

C9: Solder to the jumper wire labelled J-G between keypads 22 and 23.

Earth may be found at jumper J-A between keypads 30 and 31. You should now be able to use the octave drop, hold and sustain functions.

\*\* HARDWARE OCTAVE DROP AND PEDAL SUSTAIN \*\*

This involves adding an extra dual flip-flop I.C. to divide the clock frequency by two when a switch is flicked, and to buffer the footswitch to protect the LSI from static damage. The final circuit is as shown in Fig. 3, a D flip-flop and a switch is added between the existing two flip-flops which divide the 4.536688 Mhz down to 1.134172 Mhz for the main chip. First cut the trace that runs between pins 3 and 9 underneath the TC40H074P I.C. (this seems to be the same as a 74C74 but is probably faster). Use 5 minute epoxy resin to stick the 4013 flip-flop upside down on the

component side of the board between the crystal and the TC40H074P, scratching both surfaces beforehand will help them stick. Fold over or cut off the thin ends of the 4013's pins as they will hit the bottom case otherwise. Fig. 4 shows how the 4013 is wired up. I mounted my 3.5mm socket in the bottom half of the case below the vibrato switch.

**\*\* TONE SWITCH \*\***

This bypasses the low-pass filter so as to give a much brighter tone. In both the M-10 and MT-30 there is an 8 pin dual op-amp where Pin 1 is the output of the DAC, and Pin 7 is the output of the filter. Pin 7 drives amongst other things a 10 uf capacitor - cut the trace to the positive lead or cut this lead from the board and connect it to the common of your switch. Now connect the other two pins of the switch to Pins 7 and 1 - you now have the choice of filtered or unadulterated signal. The DAC output of the M-10 contains a lot of clock signal so if your amplifier has a flat frequency response from DC to daylight and you are worried about radio interference then you can get rid of it as follows. The clock signal gets to the LSI via a PC track from pin 5 of the 40H074 to a wire jumper, which goes to another track to pin 37 of the LSI. The wire jumper runs very close to and is capacitively coupled with the DAC resistor pack. Cut the tracks at the aforementioned pins and restore the connection with a piece of wire-wrap wire between those pins, then there will be no more clock interference.

**\*\* THE VOICE SELECT.BUTTON \*\***

The keyboard of the M-10 covers keys 18 to 49 of the 49 key range of the uPd773. Simply installing a 'Set' or 'Voice Select' button - a switch and diode for switch position 3 2 would give us access to most of the voices simply by pressing the button and the appropriate key. However there are six voices - Square, Triangle, Mysteries 1&2 and Slow and Fast Harpsicord, which can only be accessed by keys outside the range of the M-10's keyboard. Since the bottom 16 keys of this keyboard do not identify voices, these keys could be made to behave like the keys which do, while the voice select switch is pressed. This is the purpose of the following modification, so that any of the 23 voices can be selected.

This switch controls a quad two way mutiplexer, a 74C157, which performs two functions when the button is pressed:-

- 1/ Closes the 3 2 switch position - Set or Voice Select.
- 2/ Reorganizing the keyboard Common lines which drive the lower keys, which do not identify voices, so that those keys function as the lower keys of the 49 note keyboard which do identify voices.

If you look at Table 2 and the Fig 9 you will see how switching the commons of M-10 keypads 2 to 13, between thier normal C line and a different C line gives us access to all the known available voices (except 'Flute' which is accessed via 7 3 or 8 3 - the 'Funny Function' switch). Following the table is a detailed description of how to modify the keyboard commons to suit our purposes.

TABLE 2 HOW THE FUNCTION OF THE LOWER KEYS ARE MODIFIED WHEN THE VOICE SELECT BUTTON IS PUSHED

M-10 PHYSICAL KEY NO.(32)	NORMAL OPERATION KEY NO.			VS BUTTON PRESSED KEY NO.		
	(49) C	S	VOICE?	(49) C	S	VOICE?
1	18	3-9	No	18	3-9	No
2	19	4-4	No	49	1-4	= M-10 key 32
3	20	4-5	No	2	1-5	(Organ)
4	21	4-6	No	3	1-6	(Violin)
5	22	4-7	No	4	1-7	(Piano)
6	23	4-8	No	5	1-8	'Slow Harps.'
7	24	4-9	No	6	1-9	'Fast Harps.'
8	25	5-4	No	7	2-4	'Mystery 1'
9	26	5-5	No	8	2-5	'Mystery 2'
10	27	5-6	No	9	2-6	No
11	28	5-7	No	16	3-7	'Triangle'
12	29	5-8	No	17	3-8	'Square'
13	30	5-9	No	18	3-9	No

1/ Refer to Fig. 5, we want to isolate the commons of keys 2 to 7 from pin 29 which they are now connected to. Cut foil at A and B, solder in jumper of wire-wrap wire between C and D on foil side of board. Solder 6 inches of wire to pin 29 of the LSI on the foil side of the board and poke it through one of the holes between keys 8 and 10. Solder another wire to jumper J-A on the component side at D.

2/ Refer to Fig. 6, now we want to isolate the commons of keys 8 to 13 from pin 28 and split them into two groups: 8,9,10 and 11,12,13. Cut foil at A, B and C and solder a jumper between D and E. Solder a wire to F and poke it through the hole between keys 8 and 10. Solder another wire on the component side to the long jumper J-X near key 13, this is the common of keys 11,12 and 13. Cut foil at G and install jumper from pin 28 to H.

3/ Solder wires to pins 28,30 and 31 and poke them through the hole. These are C5, C3 and C2 respectively. Solder a wire on the component side to the end of the long black jumper J-1, this is pin 33 or C1.

4/ Solder a diode to S2 on the foil side of the board as shown in Fig. 7. Make sure the cathode lead doesn't touch anything, solder a wire to it and poke it through the hole. Make sure that none of these wires will get in the way of the grey cups of the keyboard. Secure with epoxy.

5/ Use epoxy resin to fix the 74C157 upside down between the 4049 IC (near LSI pin 33), and as far from the edge of the board as you can, otherwise it will hit the ridge of plastic next to the battery compartment.

6/ Wire up the 74C157 as shown in Fig. 8 and try out your new voices. If it doesn't work you will have to use your knowledge of what it is supposed to do (which I hope I imparted in the previous table and Fig. 9), your CMOS data book, your oscilloscope and your wits to make it work.

**\*\* TUNING \*\***

The top left toggle switch on my M-10 switches between crystal and variable tuning, which is adjusted by a small variable capacitor. This is accessed through a hole filed in the top and bottom parts of the plastic case at the far left end of the rear of the instrument. After much experimentation I got it to work like a charm and can tune about 3 semitones above and below the crystal. Fig. 10 is the original circuit and Fig. 11 my modified circuit, I will leave the construction details to you. Unfortunately I don't know the values of the trimcaps and inductor because they came from a surplus store and are unmarked. The trimcaps are about 8 mm in diameter and have 4 moving semicircular vanes with plastic insulation. The inductor did have a ferrite slug in it but I took it out, it has about 60 turns on a 4 mm former. Mounting the trimcap you are going to adjust is a big problem, I filed two flats on its plastic body, wedged it between the end of the battery compartment and the inside of the lower half of the case, and gingerly welded it into place with my soldering iron. The other trimcap and inductor are soldered together and are sitting in Plastitak-Blutack just behind the first trimcap. I had to keep the wires involved with the tuned circuit as separate as possible from the crystal circuit or they would interfere.

**\*\* IMPROVING SOUND QUALITY \*\***

There are three reasons why the M-10's sound isn't as good as it could be:-

- 1/ Printed circuit layout causes a high pitched whine to be superimposed on the audio signal.
- 2/ Of the 14 bits available from the LSI, only the 12 most significant are converted into sound. This means that instead of 16384 voltage steps there are only 4084. This results in sounds ending abruptly - when only bits 0 and 1 are changing, the M-10 is silent. This quantization distortion also causes two notes to intermodulate, giving a messy harsh sound to chords.
- 3/ The weighting of Bit 13 - the Most Significant Bit - of the DAC (see MT-30 adjustments) is not adjustable

and so is incorrect. This leads to the problems mentioned in 2/ above.

While these problems are not severe for the inexpensive handheld instrument that the M-10 was meant to be, they have caused me a lot of frustration so I finally attacked them. The result is that my M-10 sounds as sweet as my MT-30, which has none of these problems. The DAC is comprised of CMOS inverters, which drive 0 or 5 volts into an R-2R resistor array, which feeds a current into an op-amp, where a voltage in proportion to the current is generated. The resistors which control the weighting of bits 4 to 13 are part of a hybrid array while bits 2 and 3 are discretized.

The noise problem was the trickiest to deal with - it seems to be a combination of capacitive coupling to the common lines, and earth and power supply noise on the hex-inverter that drives the most significant bits of the DAC. Have a look at the PC traces near the dual op-amp 4485, between pin 4 and the gold contacts for A# there is a pad where a 24k resistor connects to a trace. On one side the trace goes to pin 2, and on the other it goes on a long march to the resistor array. Amputate the long track just before it gets to the 24k resistor, and follow it to a jumper that connects it to the resistor pack. Desolder the jumper at the op-amp end and cut it so that 5mm remains at the resistor pack end. Now we want to do the long march with a length of fine insulated shielded cable. At the op amp end the shield goes to pin 4 and the core goes to lead of the adjacent 24k resistor. At the DAC end, the shield goes to pin 8 of the 4049 and the core to the remaining 5mm of jumper wire. Cut the track that connects to pin 8 of the 4049, so that now it is connected to the op-amp version of earth, not the LSI version, which is noisy with respect to the op-amp. Solder a 22uF tantalum capacitor between pin 8 and pin 1 (+5V) next to the IC, this and the next step ensures that the 5V supply is noise free as well. Follow the trace that feeds pin 1 to where it passes a small hole near the G# key, and cut it next to the hole. We want to feed pin 1 through a 100 ohm resistor so as to further isolate it from noise, one end of the resistor goes to pin 14 of the 40H074P on the component side of the board and the other end goes through the little hole near G#, to the trace which leads to pin 1 of the 4049. This should get rid of the background noise.

To adjust the MSB and extend the DAC to 14 bits we need a 74C04 hex inverter, a trimpot and a few resistors as shown in Fig. 12. Yes....another IC.... your M-10 was born as just another worker at the Casio hive, and we have decided to feed it the royal jelly of modifications so that it may rise to its full potential as a Queen-Bee M-10. The problem is that this little worker was not meant to eat so much royal jelly. It is your ultimate challenge as a Casiotone Doctor to find space for these last few components. I put my 74C04 next to the crystal just over where the frequency is printed, and I epoxied my multi turn square trimpot near the op amp, just over the G# key pad. (G# in the middle of the keyboard). The 10 meg resistor goes from the wiper of the pot to the junction of the shielded cable and the 24k resistor. Try to keep the leads of the 10 meg resistor short, and away from the PC board otherwise they will pick up scanning noise. Power for the 74C04 comes from the 4049 we have just been working on. Tie the inputs of the two unused inverters to earth so they can't carry on.

The best way to adjust the MSB is to use an oscilloscope, and watch the final decay of the voice that lives under the top B key. Adjust the trimpot for a wave which remains symmetrical as it decays. If you have no oscilloscope, then adjust for the smoothest end to the note. Your M-10 should now sound as clear as a bell.

TABLE 3 - ALL SWITCH POSITIONS AND THEIR KNOWN FUNCTIONS

LSI PINS	SWITCH	KEY	PITCH	VOICE?	FUNCTION
CATH. ANODE	C S	(49)		uPd773	
33	16	1 1			None known
33	17	1 2			None known
33	18	1 3			Lowest C
33	24	1 4	49	C 5	PIANO (Top C)
33	19	1 5	2	C#1	(Organ)
33	20	1 6	3	D 1	(Violin)
33	21	1 7	4	D#1	(Piano)
33	22	1 8	5	E 1	+'Slow Harpsichord'
33	23	1 9	6	F 1	+'Fast Harpsichord'
31	16	2 1			Tuning - see text
31	17	2 2			Pedal sustain
31	18	2 3			Lowest C
31	24	2 4	7	F#1	+'Mystery 1'
31	19	2 5	8	G 1	+'Mystery 2'
31	20	2 6	9	G#1	
31	21	2 7	10	A 1	
31	22	2 8	11	A#1	
31	23	2 9	12	B 1	
30	16	3 1			Voice select 'Set'
30	17	3 2			Voice select
30	18	3 3			C Octave 2
30	24	3 4	13	C 2*	
30	19	3 5	14	C#2	
30	20	3 6	15	D 2	
30	21	3 7	16	D#2	+'Triangle wave'
30	22	3 8	17	E 2	+'Square wave'
30	23	3 9	18	F 2	
29	16	4 1			Tone memory 4
29	17	4 2			Tone memory 3
29	18	4 3			C Octave 2
29	24	4 4	19	F#2	
29	19	4 5	20	G 2	
29	20	4 6	21	G#2	
29	21	4 7	22	A 2	
29	22	4 8	23	A#2	
29	23	4 9	24	B 2	
28	16	5 1			Tone memory 2
28	17	5 2			Tone memory 1
28	18	5 3			C Octave 3
28	24	5 4	25	C 3*	
28	19	5 5	26	C#3	
28	20	5 6	27	D 3	
28	21	5 7	28	D#3	
28	22	5 8	29	E 3	
28	23	5 9	30	F 3	
27	16	6 1			Normal vibrato
27	17	6 2			Milder vibrato
27	18	6 3			C Octave 3
27	24	6 4	31	F#3	
27	19	6 5	32	G 3	
27	20	6 6	33	G#3	
27	21	6 7	34	A 3	ELEC.PIANO
27	22	6 8	35	A#3	+FROG
27	23	6 9	36	B 3	+FUNNY
26	16	7 1			Slows the vibrato
26	17	7 2			Sustain
26	18	7 3			C Octave 4
26	24	7 4	37	C 4*	(Flute)
26	19	7 5	38	C#4	+'Thin violin'
26	20	7 6	39	D 4	+ACCORDION
26	21	7 7	40	D#4	+HARPSICHORD
26	22	7 8	41	E 4	+VIOLIN
26	23	7 9	42	F 4	+TRUMPET
25	16	8 1			+CELESTA
25	17	8 2			Octave drop
25	18	8 3			Hold
25	24	8 4	43	C 4*	(Flute)
25	19	8 5	44	F#4	+CLARINET
25	20	8 6	45	G 4	+'Repeat'
25	21	8 7	46	G#4	ORGAN
25	22	8 8	47	A 4	+FLUTE
25	23	8 9	48	A#4	+CELLO
				B 4	+OBOE
*					Not normally used - see text.
+					This voice is new to the M-10.
(Organ)					Voice is called by this name in the M-10.
CLARINET					Voice is called by this name in the CT-301.
'Repeat'					My description of the voice.

TABLE 1 SWITCH SENSING PINS

PIN NO.	CASIO DESIGNATION	MY DESIGNATION
16	SI-1 SWITCH INPUT	S1 SENSE
17	SI-2	S2
18	KI-1 KEY INPUT	S3
24	KI-7	S4
19	KI-2	S5
20	KI-3	S6
21	KI-4	S7
22	KI-5	S8
23	KI-6	S9

FIG 16 THE CASIOTONE COUPLER CIRCUIT

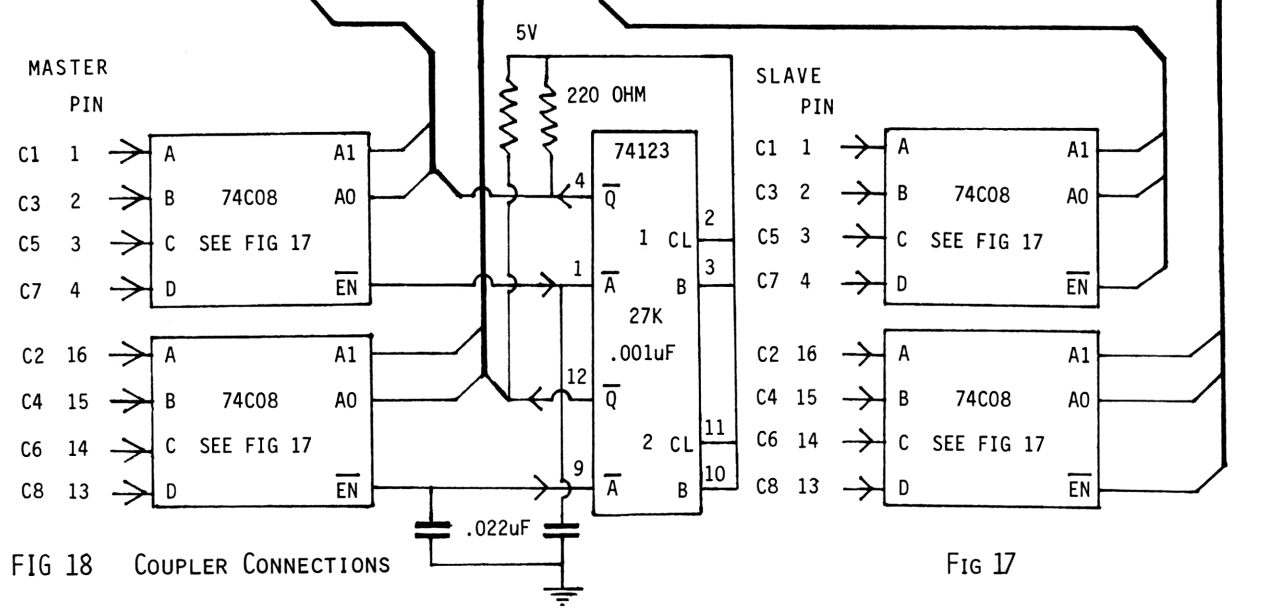
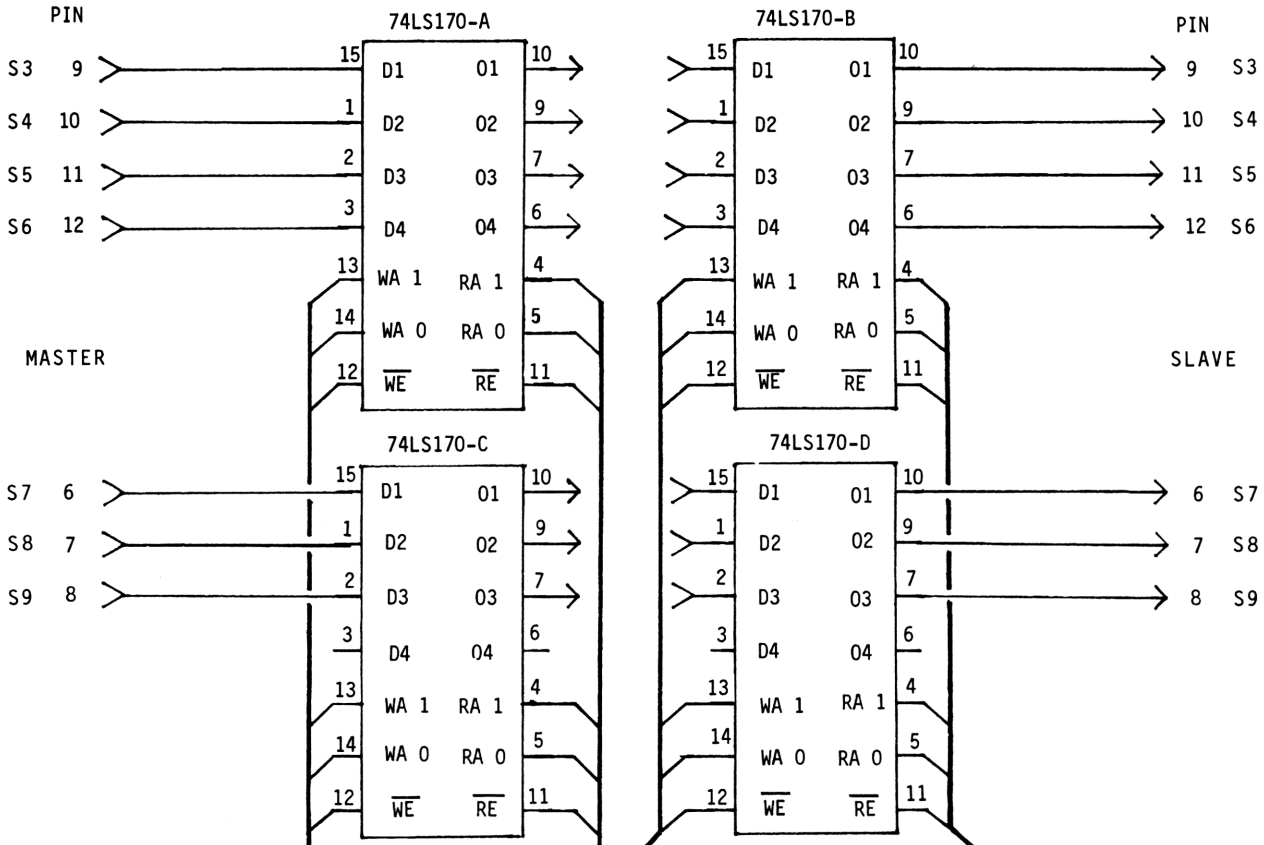
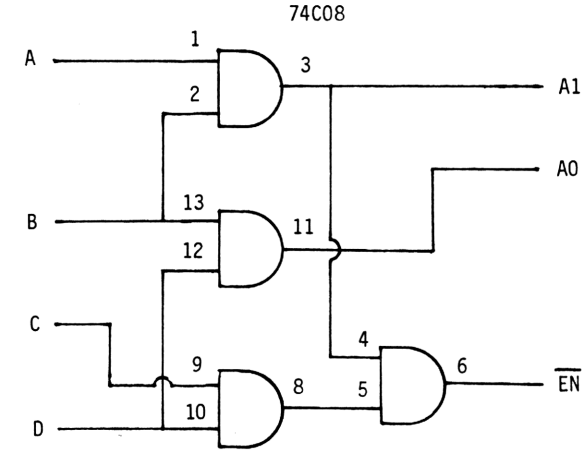

FIG 18 COUPLER CONNECTIONS

Fig 17

LSI PIN	16/18 PIN IC SOCKETS	LSI PIN
33	C1 1 1 18 16	C2 31
30	C3 2 2 17 15	C4 29
28	C5 3 3 16 14	C6 27
26	C7 4 4 15 13	C8 25
EARTH	5 5 14 12	S6 20
21	S7 6 6 13 11	S5 19
22	S8 7 7 12 10	S4 24
23	S9 8 8 11 9	S3 18
16	S1 9 10	S2 17



\*\*\* MT-30 MODIFICATIONS \*\*\*

I mounted 6 subminiature toggle switches and one miniature push-button (C&K 8121) on the left of the keyboard with a spacing of 1 cm. The toggles move sideways and are on when pushed to the right. From top to bottom they are:-

	C S	Cathode pin no.	Anode pin no.
Mild vibrato	6 2	27	17
Vibrato speed	7 1	26	16
Voice select	3 2	30	17
Hardware octave drop	8 1	25	16
Software octave drop	8 2	25	17
Hold			
Tone			

The hardware octave drop and footswitch mods will be described later, and the tone switch is described in the M-10 section. First have a look at the SUS switch; there are two PC traces emanating from the centre terminal - one to the left and underneath the grey jumper, and a second to the right where it connects to a diode. Cut the second trace. This diode was across switch position 7 1 and was causing the slower vibrato which we now want to control with a switch.

To wire up the other switches follow Fig. 13. I have minimised the number of wires that need to be soldered to the LSI by making connections via the switch PC board. Where a wire must be soldered to the LSI, you can poke the wires through holes in the PC board and connect them on the foil side of the board or solder directly to the pins on the component side. When you have checked the wiring try out the switches to see they do the right things. You may wish to add a switch for one of the 3 3, 4 3, 7 3, 8 3 positions, the 'Funny Function' - try them out with a diode and some wire, and play with the software octave drop and vibrato controls.

The hardware octave drop and footswitch sustain mods use a 4013 CMOS chip epoxy-resined to the component side of the PC board near pin 32 of the LSI. Fig. 14 is the schematic and Fig. 15 the wiring diagram. The octave drop switch selects between normal and half-speed clock frequencies, the 27k resistor stops the clock input from floating when the switch is in mid gear. When the footswitch is closed a low will appear on Q when C2 (LSI pin 31) is low. The low on the Q pulls S2 (LSI pin 17) low which "closes" switch position 2 2. This isolates the footswitch from the LSI so that a severe static discharge through the footswitch wire will blow up the 4013 and hopefully not the LSI.

Two holes are drilled in the underside of the case to adjust the tuning and the weighting of the DAC MSB (Most Significant Bit) and therefore the distortion. Both holes are to be drilled through a strengthening ridge that runs between two screw holes and are located 24 mm and 114 mm respectively to the left of the right screw hole. Make an adjusting tool from a 2 mm plastic knitting needle filed to a screwdriver point. Do not use a metal tool as this will introduce noise, interfere with and possibly damage the inductor.

The MT-30 uses a 14 bit DAC where bit 0 (pin 61) has a value of 1 and bit 13 (pin 48) a value of 8192. When there is no sound the DAC is in the middle of it's range with bit 13 1 and all the others 0 - a value of 8192. When the sound level is low - when a sound is fading away - the value changes between say 8191, 8192 and 8193 which means that bit 13 is being turned off for the 8191 part of the waveform. The real value of bit 13 is determined by the resistor package that is part of the DAC circuit and if it's value differs from 8192 then distortion will be introduced. To adjust the distortion to a minimum select the glockenspiel voice and turn on the hardware octave drop and hold. Turn up the volume, press a key and adjust the trimpot for the smoothest decay - the sound should fade smoothly to nothing. Alternatively look at the waveform on an oscilloscope and adjust for the verylast part of the sound to have a symmetrical waveform. If you are interested in distortion, a I am occasionally, you can introduce distortion to many of the voices with this trimpot. The voices that will not distort all have positive going waveforms and so bit 1 never changes. Another method of introducing distortion is to earth one or more of the output pins of the LSI - pins 4 to 13 are bits 13 to 0 - thereby forcing that bit to 1. To lower the bit no. the more subtle the distortion.

FIG 13

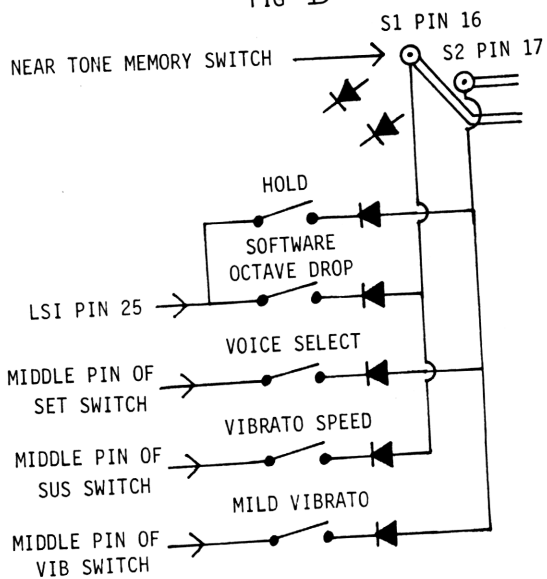

FIG 14

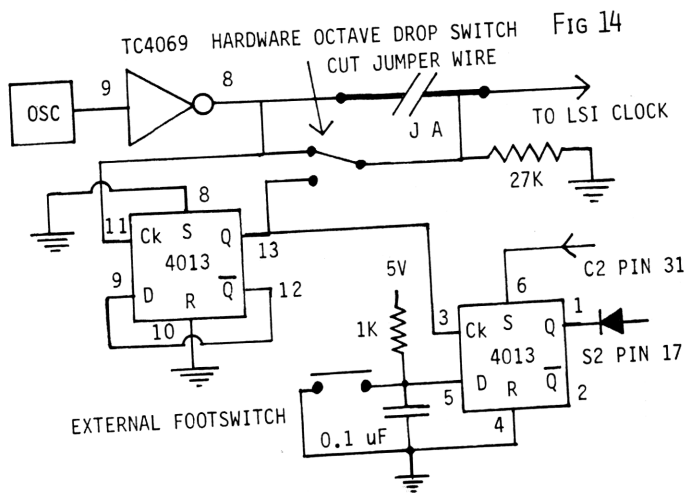
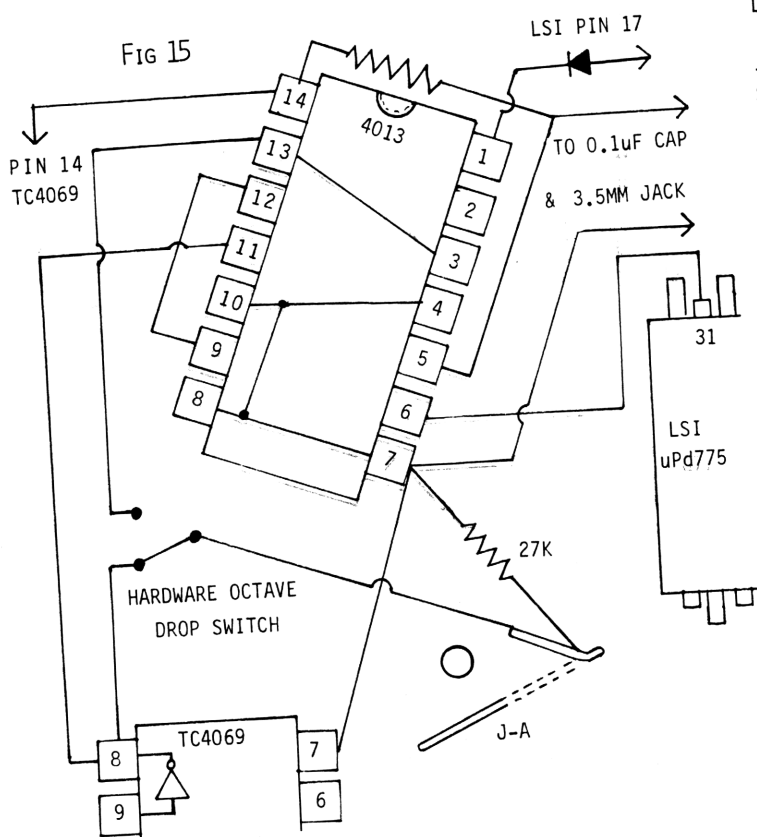

FIG 15



\*\*\*\* FURTHER MODIFICATIONS \*\*\*\*  
\*\*\* THE CT-201 AND CT-202 \*\*\*

Although I have not pulled one of these instruments apart yet, I do know that they both employ two LSI chips running in parallel, to produce two different waveforms which are individually filtered before being mixed. Maybe towards the end of 1981 I will buy a CT-202 and carry out the following mods:-

\*\* INDIVIDUAL AUDIO OUTPUTS \*\*

Provide extra output jacks on the rear panel for the unfiltered outputs from the DACs, so as to allow stereo or separate treatment of the sounds.

\*\* INDIVIDUAL VOICE SELECT \*\*

Provide two 'Set' switches - one for each LSI so that LSI 1 can be set to play its part of voice X while LSI 2 plays its part of voice Y. This allows a large number of hybrid voices. Hopefully switch position 3 2 will be a silent 'Set' as in the uPd775.

\*\* INDIVIDUAL HOLD, SUSTAIN, VIBRATO ETC. \*\*

Switches to individually control software octave drop, hold, sustain, vibrato level and speed for each LSI. Maybe the tuning switch position 2 1 could be used to make one LSI slightly out of tune with the other over the lower part of its range.

\*\* HARDWARE OCTAVE DROP \*\*

Can only be applied to both chips at once because they have to stay in synchronisation to sense the switches properly.

The musical implications of all this are enormous. The modifications would be quite simple, but the placement of the switches could be tricky. To carry out the mods:-

- 1/ Cut the tracks that drive pins 16 and 17 of each LSI and instal a diode over each of the four cuts, with the anode going to the pin. This allows the control switch positions of each LSI to be driven independently.
- 2/ Instal the switches and diodes for the functions you want to control - anode to pin 16 or 17.
- 3/ Instal two output jacks connected directly to the DAC outputs. The DAC probably consists of CMOS inverters driving a resistor pack and discrete resistors which feed a current to an op-amp, which turns it into a voltage. The output of the opamp is what you want, via a 1k resistor or buffer amplifier.
- 4/ Use the hardware octave drop circuit described herein, preferably before the flip-flop which drives the LSIs, so that they get a nice clean clock signal and stay synchronised.

In addition I would convert the DACs to 14 bits if they were not that already - as described in the M-10 section, and instal a connector for the coupler described below.

\*\*\* COUPLING AND COMPUTER INTERFACING \*\*\*

Recently I built a circuit which couples two Casios so that pressing a key on the master results in the slave playing that note as well. I use my MT-30 as a master for the M-10 because the MT-30 has a larger keyboard. By the end of the year I hope to have acquired a CT-202 and built a box with three coupler circuits, this will allow me to play the MT-30 and M-10 plus a friend's M-10 from the CT-202 - a four octave range for all instruments. The main value of the coupler is that it allows you to play two entirely independent voices with differing octave, sustain and vibrato settings by pressing one key. The two instruments can be tuned differently, sent through different EQ and processing devices and their sounds may even issue forth from different speakers.

With my two instruments, a graphic equaliser, a flanger and a spring reverb unit, I have been able to make the most beautiful sounds. Two similar harpsicord tones with slightly different tuning, one going through a flanger and

the other through the graphic, sounds much better than just one voice. The M-10 doing its triangle wave voice with no sustain, several octaves below the MT-30's trumpet voice with sustain sounds like nothing on this earth! The windows and floor rattle while you press the key, and the fine trumpet tones slowly fade away. On my arbitrary scale of musical value, the M-10 and MT-30 score 8 and 20 points in their original state, and 60 each when fully modified. I would say that the combination of these two instruments, the coupler and a few processing devices weighs in at a good 300. If you are interested in recording, can carry out the modifications and can get hold of the money - about \$400 - without starving then I can highly recommend the above configuration. Once you have it you will feel like chucking your string synthesiser out the window, so selling it will cover your costs.

The circuit is based on the 74LS170 4 by 4 register file which consists of 16 flipflops accessed in groups of four. The read and write circuits are entirely independent so that keyboard information can be read by the slave while it is being written by the master. Since the keyboard is scanned in 8 groups of seven switches, four 74LS170s are required. The complete circuit requires 9 ICs and is shown in fig. 16. Chips A & B handle sense lines 3, 4, 5 & 6 while C & D handle 7, 8 & 9. Chips A & C store sense data when the odd numbered common lines are active and B & D work on the evens. When a key is pressed the sense line is low and so a 0 is written - when the slave reads that location, the memory (which conveniently has open collector outputs) pulls down the sense line and the slave LSI thinks you have pressed a key. Each 74C08 circuit encodes four C lines (as shown in fig. 17) into two bits of address and an active low enable, which is sent direct to the 74LS170s for reading. To avoid writing rubbish during the rise and fall of the master's common lines a narrow, delayed write pulse is needed - hence the capacitors and monostables. I had trouble with one mono sending spikes to the output of the other, causing erroneous writing, and the 220 ohm resistors fixed it, so maybe you will need them too.

I made connection to the instruments by installing a 16 pin solder-tail IC socket mounted inside the case, on the left side of the top half of the case for the M-10 and on the back of the bottom half for the MT-30. The sockets are held in place by two screws tapped into their plastic bodies. Sixteen 1mm holes are drilled in the case so that a wire-wrap socket can be inserted and connect with the IC socket. A 16 pin jumper cable plugs into the WW socket and leads to the coupling circuit. The idea of all this is that the connector should not protrude from the instrument, or be vulnerable to static electricity when not in use. The easiest way of gaining access to the signals from the LSI is by direct connection as I have done, but this does not protect against static damage via the jumper cable when the instrument is connected to the coupler. The safest way out is to feed all the signals through TTL buffers, such as a 74LS241 for the Common lines which are always driving the connector. If the instrument is always going to be the master then the Sense lines can be buffered in the same way, but it is to be a slave then the 74LS241 must drive the LSI through diodes. Since there is plenty of room in the CT-202, and it is a costly instrument, I will definitely buffer its coupler connections, and use a toggle switch to control the Sense buffer direction.

The VL-TONE uses an eight by nine switch sensing matrix, like the other instruments, but the pin connections and arrangement of switch functions are totally different. So it would be possible to couple a VL-TONE to another VL-TONE, or to a computer, but not to one of the polyphonic instruments. If you are interested in VL-TONE switch positions I can send you a chart of there function.

This coupling circuit has obvious applications for computer interfacing because it is totally asynchronous. If you simply want to make the Casio play notes under computer control then one coupler is all you need, but if you want to be able to read its keyboard simultaneously, or better still the keyboard of another instrument then you will need two. If one end of your coupler is always going to be connected to the computer then you can drive the data, address and enable lines of the 74LS170s directly, thereby saving a few ICs and computer I/O lines. If you want to control the voice selection, vibrato, sustain etc. directly from the computer then you will need to expand the coupler to deal with the Sense lines 1 & 2. Since Sense 3 is only used for the lowest C, you could invent a special latch for it and feed Sense 1 and 2 to ICs C & D. This of course means more than 16 pins of connection to the instrument, and so fig. 18 shows

connections for 16 and 18 pin sockets. I think it would be a good idea if all modified Casiotones followed this connection pattern so that there will be no hardware interface problems at the forthcoming International Casiotone Modification Conventions. I envisage a grand coupling event involving N couplers and N + 1 Casiotones, where N is quite a large number. Since all unbuffered instruments could easily be damaged by static electricity, I propose that cats and other species of small furry animals be specifically excluded from these Conventions.

\*\*\*\* CONCLUSION \*\*\*\*

The Casio Computer Company has provided us with some wonderful instruments, but it seems that they hid some features they could easily have made available so that the average consumer would not be confused by a large number of switches. I hope they realise that this was in many ways an incorrect assumption - the VL-TONE has lots of buttons and at first is quite confusing to use, but it has sold very well. Home organs have pretty colored buttons and stops all over them, and consumers just love them! For most musicians, the key question when evaluating a musical instrument is 'How well can I express myself with this instrument?'. This boils down to 'How much control do I have over the sound?' The reason I bother modifying Casiotone instruments, and the reason that people are more than happy to pay me \$80 to modify their \$100 M-10 is that the extra expression made possible by the extra controls makes it all worthwhile.

I hope that Casio and other manufacturers can in the future supply us with inexpensive portable instruments with the greatest musical control possible. I am primarily thinking of user programmed voices and scales, but look forward to a real-time input system with more tactile control than the on/off organ keyboard. Velocity and pressure sensitive keyboards are the obvious beginning - perhaps the increased computational demands this entails could be met by using 8 identical LSIs for an instrument with 8 note polyphony. The mouth, which is traditionally used as an important real-time communication channel, is almost totally ignored by electronic instrument designers - I can only think of one synthesiser interface that uses breath and lip pressure sensors, the 'Humaniser'. The biggest failing of physical instruments is that they have only one sound, and the biggest failing of electronic instruments is that they lack tactile control. If someone can mass produce a portable electronic instrument with programmable voices and tactile control, even if they are not cheap, the musicians of this world will buy tens of thousands of them.

\*\*\*\*\* GREAT MOMENTS IN PHILOSOPHY Part XVII \*\*\*\*\*

There are many people who think that the primary reason that I spend so much time building electronic machines and programming computers is that I like doing so. While it is true that I would rather work on a computer than on a car, my primary reason for dealing with technology is to build better musical instruments. If I could build a musical instrument with the flexibility or expressive capability that I am aiming at by carving a piece of wood for five years, then I would prefer to do it that way. Technology fills my mind with otherwise useless information, and distracts me from the sensual and emotional feelings that drive me to make music. Technology is a can of worms - I organise the worms to form an instrument, screw the lid down tight and play.

\*\*\*\*\*

Write to Mr Noriaki Shimura at the Casio Computer Company, and give him feedback on the instruments you own, and your hopes for the future. If there is anything in this blurb which is unclear to you, write to me and I will do my best to help. If you can think of any publication or organisation through which I could publicise this information, please let me know.

I would be glad to hear of your musical activities and your experiences with modified Casiotones. Please keep in touch.

THE CASIOTONE M-10, MT-30 AND VL-1 - THE SMALLEST COMPUTER MUSICAL INSTRUMENTS

This is an edited and updated version of the paper I presented at the International Music and Technology Conference held at Melbourne University in August 1981.

\*\*\* Introduction \*\*\*

At the time of writing the Casio Computer Company have released seven musical instruments :-

- CT-201 - Introduced in mid-1980, this is a mains powered four octave instrument which features 29 voices, vibrato and eight note polyphony.
- M-10 - A battery operated portable instrument featuring four voices and vibrato. The two and a half octave keyboard uses keys that are 11 percent smaller than standard.
- CT-301 - Mains powered, four octave, 14 voice instrument with vibrato, delayed vibrato, adjustable tuning, woodgrain finish and built-in drum machine.
- MT-30 - Portable battery operated instrument like the M-10 but with three octave keyboard, 22 voices, sustain, and a larger speaker. Introduced early 1981.
- CT-401 - Similar to the CT-301 but with automatic chords, sustain, hold, and a more sophisticated drum machine.
- VL-TONE - Totally different from all the above, monophonic, six voice, 29 miniature 'keys' with liquid crystal display. This hand-held device features a hundred note melody memory with editing facilities, ten rhythms and variable speed for the melody and rhythm. The VL-TONE doubles as a four function calculator, the memory of which programs the sixth voice in terms of waveform, vibrato, tremolo and ADSR parameters.
- CT-202 - Replacement for the CT-201, has 49 voices and 3 vibrato settings.

The topics I want to cover in this paper are:-

- 1/ The inner workings of the instruments
- 2/ My modifications to them
- 3/ Their musical significance

\*\*\*\* THE INNER WORKINGS OF THE INSTRUMENTS \*\*\*\*  
\*\* THE VL-TONE \*\*

According to Mr. Noriaki Shimura, the president of the Casio Computer Corporation, the VLSI chip that is the heart of the VL-TONE is equivalent in complexity to a 64k RAM and is the most complex chip ever developed for a consumer product. This means that it must contain about 70,000 transistors - nine times more than a Z-80 processor. The 64 pin chip senses switches using 8 drive and 9 sense lines like the chips in the other instruments. Twenty of these switch positions are unused, one is permanently closed by a diode (without it the audio amplifier is not turned on) and the remaining 51 are connected to pushbuttons and slide switches. The main chip drives the liquid crystal display underneath which it is mounted, controls the power to itself and the audio amplifier, and has two analog outputs for rhythm and melody. If the VL-TONE is not used for three minutes or so the internal programs commit hara-kiri by turning off the computer they are running in - as a friend put it: 'For the honour of the batteries I will turn myself off!' A capacitor maintains the melody memory while the batteries are changed, but no amount of discharging or interference will erase the indelibly programmed 'German Folk Song'. All the wave forms are square waves of different patterns - volume is varied by changing the top voltage of the wave.

\*\* THE POLYPHONIC INSTRUMENTS \*\*

The VL-TONE's chip is quite different from the chips in the remaining Casiotone instruments, which all have the same pin connections and respond almost identically to the switch matrix, but differ in which voices are assigned to the keys. The CT-201 uses a uPd771 and uPd772 synchronised together in what is called 'The Unique Casiotone Consonant/Vowel System', both run from the same clock and are reset together so they are always in step. One chip

drives the switch matrix but they both sense it and produce their own digital waveforms, which are fed to separate 14 bit digital to analog converters. The volume and filtering of the two signals are controlled by the two LSI's and change from voice to voice. The full 49 note capacity of the chip is used and there is a voice for every white key. There is a four position 'Tone Memory' switch which gives the user a choice of one of four voices - voices cannot be mixed in Casiotone instruments. Moving the Play/Set switch to set and pressing a white key will load the voice associated with that key into the current tone memory position, and an A note using that voice is played. Vibrato and the external sustain pedal drive two more switch positions. The CT-202 uses 2 LSI chips also and has 49 voices, and normal and mild vibrato settings.

The M-10 uses a uPd773 and makes use of only 12 of the 14 available audio output bits. Thirty-two switch positions are used for the keyboard, one for vibrato and four for the tone memory switch. Since there is no set switch in the standard instrument, the tones cannot be changed from piano, flute, violin and organ.

The same chip is the heart of the CT-301 in which 14 of its 23 possible voices are made available to the user. Although the CT-301 has no set or tone memory switch, pressing one of the 14 sound selection buttons is the equivalent of closing the set switch and hitting a white key as in the CT-201 except that no sound is made. The LSI also provides a binary output to drive one of 14 LEDs to indicate which voice is currently selected. The CT-401 probably uses a uPd773 because it has the same 14 voices as the CT-301, and must use a second chip for automatic chord section of the keyboard. This section has a fixed timbre and can produce a walking bass line in synchronism with the drum machine. Both the CT-301 and CT-401 have delayed vibrato which is produced by varying the clock frequency.

The MT-30 uses a uPd775 which is similar to the uPd773, except that it has 22 voices, and that one of the two 'set' switch positions plays the voice at middle C like the CT-201 whereas both 'set' positions of the uPd773 are silent. The digital to analog converter uses all 14 bits and has a trimpot to adjust the weighting of the most significant bit, so as to minimise distortion. The clock frequency is controlled by an inductor, which can be adjusted if a hole is drilled in the bottom of the case. Like the M-10, the audio signal is passed through a low pass filter with two possible cut-off frequencies before being amplified.

I have spent hours gazing at an oscilloscope trying to figure out how the uPd77x chips work, and have come to no firm conclusions. Some of the observations are as follows. The LSI has four input/output sections:-

- 1/ Switch Matrix - scans all 72 possible switch positions.
- 2/ Output port for LED and filter control.
- 3/ Liquid crystal display interface - not used
- 4/ Special sound producing section - 14 bits output to DAC.

The LSI's internal clock frequency is 567.086 kHz and the switches are scanned in 8 groups of 9 every 1.58 msec - every 896 clock cycles. This means 112 clock cycles for each of the 8 groups of switches - 16 for each of the 7 switches which are sound producing keys. The timing resolution of any one note is 12.64 msec signifying that only one of the 8 sound channels is updated every scan. By observing single note waveforms for different voices I have observed patterns in the way they they are apparently constructed, which may give clues to the internal structure of the LSI.

Voices such as organ and flute have a fixed waveform that increases linearly in volume, stays at the maximum volume while the key is held, and decays at half the initial rate when the key is released. The attack and decay rates are doubled for a note an octave lower - indicating that the volume register is clocked by the waveform. If the sustain switch is closed, the decay is much slower and unrelated to pitch. Other voices exhibit more complex behavior - they may start at maximum volume, or increase volume with one waveform and then abruptly change to another, as in the MT-30 'Funny Fuzz'. The voices which change timbre seemingly do so by varying the volume of two different waveforms which are summed to form the total. There seem to be 32 time divisions per wave and at least 32 linear volume steps. Most of the waves are quite geometric, suggesting that they are defined by gates rather than ROM. Vibrato is applied to all notes simultaneously by lengthening and shortening some of

these sample times and then further shortening the shortened ones to cause the vibrato. It seems to me that each waveform is the sum of two processes, in each of which a 32 sample 5 bit waveform data stream is multiplied with a 5 bit volume register to form 10 bits. These two are added to produce the 11 bit waveform for that sound channel. The outputs of the eight sound channels are added together to form the 14 bit total output.

An interesting way to observe these processes is to turn on the MT-30, turn the volume up full and without playing a note put the speaker to your ear. What you hear - I think - is not the DAC but earth noise caused by the variations in powersupply current drawn by the LSI, which is a reflection of the processes inside. Now change the tone memory switch, play with the software octave drop, vibrato and vibrato speed switches. What I hear in mine seems to be all 8 sound channels playing the current voice at one pitch; if I play a few notes the sound no longer has such a distinct pitch. All these waveforms are going on all the time but the volume registers are zero. The stunning fact is that the output is accurate in the time domain to one clock cycle - 1.763 usec which represents a data rate of about a megabyte per second, equivalent to the text of 'The Lord of the Rings' every three seconds. I have now concluded that the uPd77x LSI's are most likely composed of hardwired logic and memories and probably do not contain a computer, which casts a shadow of doubt over the title of this paper.

Recently I spoke with the Australian representative of the Allen Organ Company of Pennsylvania, who have been world leaders in the field of digital synthesis organs since 1971 when they gained exclusive rights to a number of digital musical instrument patents. He told me that the chips used by Casio in their polyphonic instruments are partly photographic copies of a chip developed by Rockwell for the Allen 'Musically Dedicated Digital Computer'. He says Allen does not want to interfere in the computer music field but is interested in stopping anyone competing unfairly with them in the 'church organ' market by using pirated technology. Allen are at present suing Casio on the grounds of alleged patent violation and are seeking royalties for the use of their technology. Casio want the case heard in a Japanese court.

\*\*\*\* MY MODIFICATIONS \*\*\*\*

After waiting for over a month, I took delivery of my M-10 a few days before Christmas 1980. A day later I installed a switch and flip-flop to halve the clock frequency, and in doing so discovered that if the instrument was turned on without the clock connected, then different voices would sometimes be available. The next evening I went over every pin of the LSI with an oscilloscope, and connected the 17 switch sensing pins to an external connector. I explored the 72 possible switch positions and found sustain, hold, octave drop, and mild vibrato functions as well as two 'set' positions. These in combination with the black and white key switch positions, allowed for 25 voices to be selected in a similar fashion to the CT-201, although silently. Another switch position 8-3 gives rise to the 23rd voice - the flute. You can well imagine my excitement in the early hours of the morning when I discovered all this! The next evening I installed miniature toggle switches to allow variable tuning and give easy access to the above features, and carried out the same modifications for a friend just in time for Christmas. The next week I wrote the modification instructions - 'How to get twenty-five voices from your Casiotone M-10' because I knew that a lot of people would want their M-10 modified and I did not want to do all the work - although I work as an electronic technician I would prefer to concentrate on music. I mailed copies of this technical bulletin to magazines and friends of friends in Europe and America to spread the word, and converted several M-10's.

In March I bought an MT-30, checked out its switch positions and discovered the true purpose of switch positions 7 1 - vibrato speed drop and 2 2 - a continuous sustain suitable for a foot pedal. The MT-30 was duly modified with every conceivable option and the second blurb written - 'Modifying the Casiotone M-10 and MT-30'. It seems that the first person to propose modifications to Casiotone instruments was Richard Wilson of Texas who published a method of obtaining extra voices from the M-10 in 'Polyphony' in late 1980.

A fully optioned M-10 has the following extra features:-

Variable tuning Toggleswitch on left of keyboard and trimcap mounted in rear panel.

Funny function Toggleswitch on left of keyboard - switch position 7-3 or 8-3. Equivalent to pressing a key - sometimes plays middle C, other times retunes itself while you play and does radical frequency modulation.

23 voices Simultaneously press the voice select (set) button on the left of the keyboard, and the appropriate key.

Mild Vibrato Toggleswitch on left of keyboard.

Slow vibrato Toggleswitch on left of keyboard.

Hardware octave drop Toggleswitch on right of keyboard, halves clock frequency. This drops the sounds an octave and slows the decay and vibrato a factor of two.

Software octave drop Toggleswitch on right of keyboard. All sounds drop one octave.

Hold Toggleswitch on right of keyboard. Single or multiple notes are held until another key is pressed.

Sustain Toggleswitch on right of keyboard. Sounds decay slowly when key is released.

Tone switch Toggleswitch on right of keyboard bypasses the lowpass filter.

Pedal sustain A foot-switch plugs into the rear panel. Up to a limit of eight, all notes played are sustained until the foot-switch is released.

The fully optioned MT-30 supports all the above functions with these exceptions :-

Variable tuning Achieved by drilling a hole in the bottom case and adjusting an inductor.

Voice select button No new voices are added, but they are selected silently.

Distortion Another hole is drilled so that the DAC MSB can be adjusted to null or create distortion to taste. This control is not always optimally adjusted when the instrument leaves the factory.

A possible modification to the CT-202 would be to install a separate voice select switch for each LSI. You could have LSI A playing the A part of "Shakuhachi" combined with LSI B playing the B part of 'Bandonion'. Perhaps two switches and a few diodes would allow over a thousand hybrid voices! Controlling the vibrato, sustain, hold and software octave drop independently for each LSI would further multiply the possibilities.

\*\*\*\* MUSICAL SIGNIFICANCE OF THE PORTABLE INSTRUMENTS \*\*\*\*  
\*\* PORTABILITY + AFFORDABILITY = ACCESABILITY \*\*

These battery operated hand-held instruments can be used anywhere you can possibly think of - unless it is raining. This means they will be used far more than they would be if they were bulky or needed external power. I generally take some of them with me when I visit friends because it is easy to do so and if I don't, they often say 'Where's your little instrument?' This portability is actually a fiendish Japanese marketing strategy designed to transform a Casiotone owner into a travelling salesperson. I have played polyphonic keyboards in the bush, miles from the nearest power outlet. A hitch-hiker once played Beatles songs on the M-10 plugged through the car sound system as we sped along Highway One. Sit it on your lap, swing it around the room - the instrument comes to you.

The three instruments under consideration are all very affordable, anyone in the western world would be able to buy an MT-30 for a weeks wages or less. Most people I know who really liked my instruments, bought one for themselves within a month, while some took less than a day.

Twelve of my immediate friends own fourteen Casiotones. Tens of thousands have been sold in the last year, you can even buy a VL-TONE - a bona fide computer musical instrument - in shops which have nothing to do with computers or music.

\*\* Tactility \*\*

These are some of the few electronic instruments which vibrate when you play them, just like a physical instrument. The VL-TONE has tiny keys but with a few hours practice it can be played very quickly - I have rounded the corners of the keys and lowered the black ones so I can slide my fingers over the keyboard. I find the keys on the M-10 and MT-30 to be light and easy to play, but experienced pianists find it very frustrating because their fingers will not fit between the black keys when playing chords. Being accustomed to seven octaves they also find that two and a half or three cramps their style.

A major advantage to the instruments' small size is that they can be stacked so that the keyboards are very close, allowing totally new playing styles like one-handed two-voice chords and simultaneously or alternately playing the same note on two separate instruments. My keyboard stack consists of the VL-TONE Blu-Tacked on top of the M-10 which sits on top of, and is aligned with the MT-30.

\*\* Sound quality \*\*

The VL-TONE has a rough sound compared to the others, so I often use my Korg MS-20 voltage controlled synthesiser to follow its pitch. This allows tremendous versatility, overcomes the background noise problem and can make it sound like a ton of bricks. The MT-30 has a lovely collection of voices which are expanded considerably by the modifications, while the M-10 has an equally varied set with some really unusual voices not found on the MT-30. While most of the voices are imitations of existing instruments, I see them as all as sounds unique to these instruments.

\*\*\*\* Conclusion \*\*\*\*

I am critical of a few aspects of the Casiotone instruments - mainly features which could have easily been added. A key on the VL-TONE to allow continuous repetition of the user's melody would extend its usefulness considerably. A switch, a diode and a rearrangement of the voices would give the M-10 23 voices instead of 4. It is obvious from the popularity of my modifications that musicians and non-musicians alike are very interested in an instrument with lots of possibilities, however with the exception of the VL-TONE, all the instruments are capable of much less than their LSI heart's potential performance. There are three reasons why Casio should limit the instruments in this way:-

- 1/ So that you have to buy a more expensive instrument to get all the features.
- 2/ To cut down on the number of switches to keep production costs down.
- 3/ To make clean, simple looking instruments that will not confuse the potential buyer.

I give little credence to the conspiracy theory No.1 and think that No.2, and mainly No.3 are the real reasons. Looking at my friends it is easy to see that Casio has underestimated the sophistication of this group of consumers - we want lots of flexibility and are prepared to pay for it. It is clear that they have the broadest possible market in mind - they have constricted and dressed up this wild piece of silicon and successfully sold it as a docile consumer durable.

In my view there have been three major milestones in electronic instruments in the last five years - the big computer musical instruments, the programmable analog polyphonics and the Casiotone instruments. Clearly the first two have tonal possibilities well beyond the third, but the introduction of the portable, inexpensive Casiotones has allowed music to be played with new sounds, in places where it would never have been played, by people who would never have played it before.

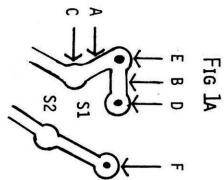

Fig 1a

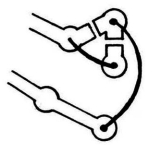

Fig 1b

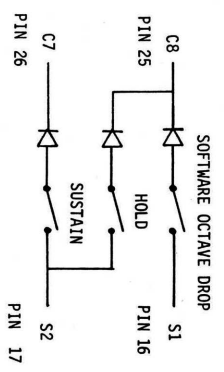

Fig 2

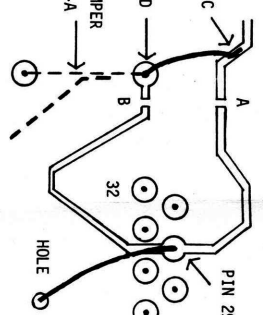

Fig 5

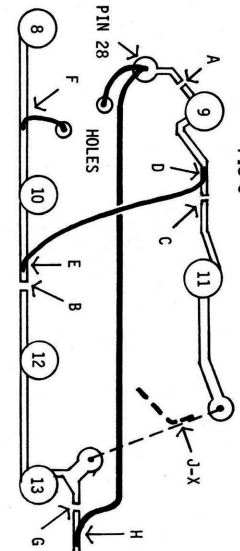

Fig 6

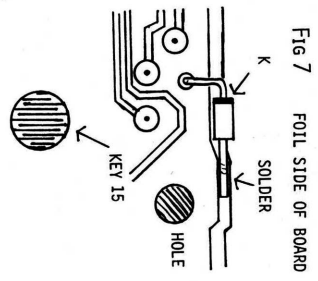

Fig 7 FOIL SIDE OF BOARD

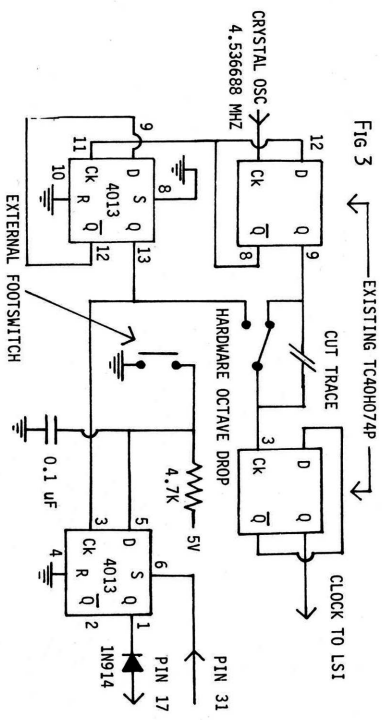

Fig 3

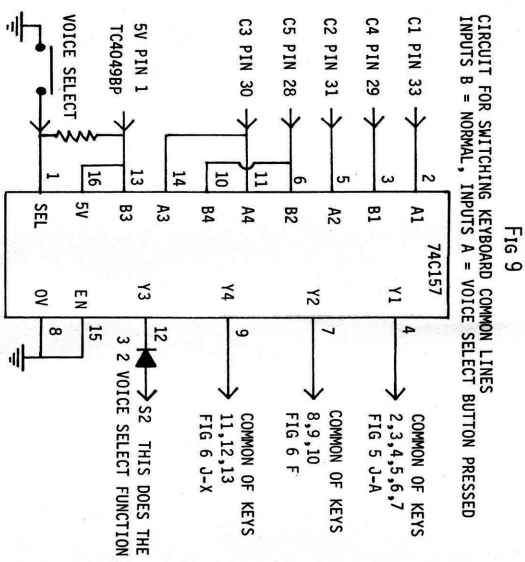

Fig 9

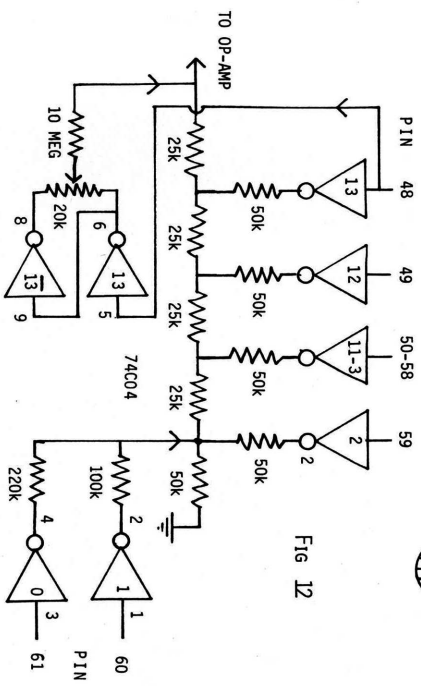

Fig 12

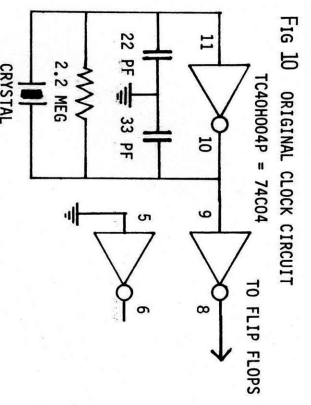

Fig 10 ORIGINAL CLOCK CIRCUIT

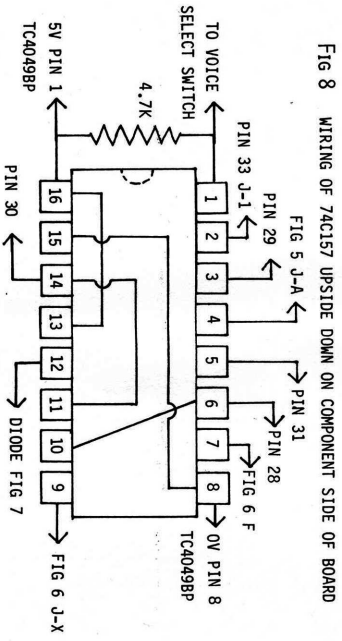

Fig 8 WIRING OF 74C157 UPSIDE DOWN ON COMPONENT SIDE OF BOARD

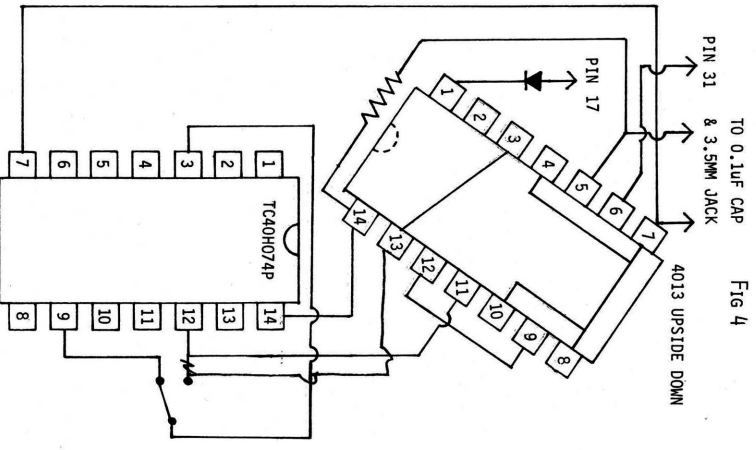

Fig 4

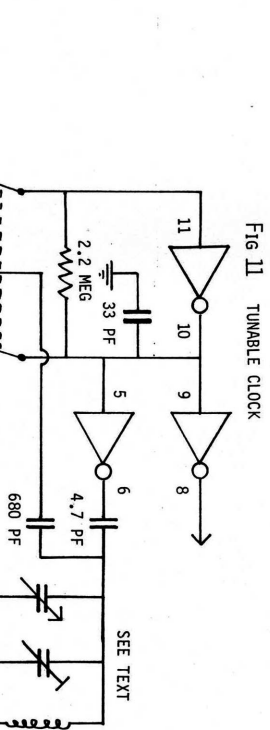

Fig 11 TUNABLE CLOCK

## Update to the 1981 booklet: MODIFYING THE CASIOTONE INSTRUMENTS

This is an archival document - addresses etc. are out of date.  
See <http://www.firstpr.com.au/rwi/casio/> for latest details.

Here is the text of what I used to send as an update with my Casio modification details, together with a sheet showing figures 16 and 17 for instrument rate and filter bypass circuits. I also put in a sheet showing how to get a high quality signal out of a VL-5. - Robin

\*\*\*\* STOP PRESS \*\*\*\* STOP PRESS \*\*\*\* STOP PRESS \*\*\*\* 1st September 1983 \*\*\*\*

Stop the world - I want to come to terms with yesterday! Casio have introduced dozens of instruments since this bulletin was written. The CT-201, 301, 401, 101, 403 and 202, the M-10(MT-10) and the MT-30, 31, 40(41) and 60 are what I call the Series I instruments. They are all based around LSI chips similar to the uPd-773 of the M-10. This bulletin is therefore generally applicable to all series I instruments. I call the VL-1, VL-5, and the PT-20-30-40 the Series II instruments although they are all quite different from each other. The Series III instruments are the CT-701, 601 and 501, the 1000P and the MT-70. I have not seen inside the MT-11, or MT-45 (Series IV) yet because they do not sound very inspiring at all. Series V are the MT-65, CT-405 and CT-7000, and these are really worth getting excited about! The sounds are brilliant by any standards - better in my opinion than the Series I - and the sound LSI puts out 16 bits, only 14 of which are normally converted. I have made a good 16 bit anti-glitch DAC and can tell you that the results are stunning. The series III instruments use a Z-80 like microcomputer - and two or three identical 42 pin Hitachi chips to produce the sound. The computer scans the keys, organises everything, and talks to the Hitachi chips via an 8 bit data bus. The Hitachi chips produce 12 bits of digital audio with a 25 Khz sample rate and control an attenuator which follows the DAC. Each chip produces 4 waveforms which are composed of variable amounts of the first 8 harmonics, the levels of which can be changed in each channel in real time. It is impossible to make the computer run another program. Bypassing the lowpass filter gives a brighter tone, but adds to the already unacceptable noise level. I have had little success in getting rid of this noise - it seems to come from everywhere, and therefore I cannot see much point in trying to do anything more with these instruments.

At present I know of three people (in addition to myself) who are offering a Casiotone modification service :- Bob Hoke R.D.7 - Druck Valley Rd. York PA 17402 USA Ph.755-0332; D.J Perkins 31 Bone St. Morphett Vale 5162 S.Australia Ph. 08-382-6838; David Cahill (Melbourne Australia) Home Ph. 03-419-6038. My home phone no. is 03-459-2889 or 61-3-459-2889 including Australia's country code number. My permanent postal address is 42 Yeneda St. Nth Balwyn 3104 Melbourne Australia.

David Cahill and I have found that some of the uPd-77x chips will run with twice their normal clock speed, and so the hardware octave drop has been renamed slow instrument rate, and a centre off toggle and two sections of a CD4066, select between slow, normal and fast instrument rate. Only about half the LSI chips we have done this to will work properly on all voices at the fast rate, but it is still well worth trying. Normally the clock is fed into LSI pin 37 where it is divided by two and, when pin 38 is low, fed to pin 35 and the rest of the LSI chip. If you cut the track to pin 38 and connect pin 35 to pin 37, then your clock signal will drive the LSI without being divided by two, and your instrument will run at the fast instrument rate - twice the normal speed. For all instruments cut the trace that drives pin 37 and install the circuit shown in Fig. 16, with the following exceptions :- The CT-101 - has a sinusoidal clock signal so square it up with a 74C14 before feeding it to this circuit. In the CT-202 apply this circuit to the left LSI only - its pin 35 drives the same pin on the right LSI. In the MT-40 and CT-403 the clock oscillator drives pin 2 of the 8049/9 microcomputer and the divide by three output on pin 1 is used to drive the LSI, so if you make an independent divide by three circuit to drive the LSI you can install a divide by two circuit in the pin 2 circuit of the 8048/9 and move the bass down an octave.

The generalised filter bypass circuit is shown in Fig. 17. - the switch selects between filtered and unfiltered signals. C1 and R1 decouple the DC voltage present on the DAC output so that no clicks are heard when switching. A better alternative to the switch is a 10k pot so you can select any mixture of filtered and unfiltered sound. The problem with the small instruments is where to put the pot. A third, more compact alternative is to use a centre off toggleswitch such as the C&K T-103 with a 10k trimpot across it - when the switch is in mid position, the mixture is controlled by the preset pot. For high quality audio output, and stereo outputs for the CT-202

you should take your signal via a 10 uf capacitor and 1k resistor in series from the common of the switch (or pot) so that the sound quality is not degraded by further unnecessary amplification. For the M-10 and MT-30 the outputs of the filter and DAC are pins 7 and 1 respectively of the 4558 dual op-amp while for the MT-31 and MT-40 the filter is pin 1 and the DAC pin 7. The DAC output of the CT-101 and CT-403 is the "DA" test point and the filter output is pin 3 of the 4066.

In all instruments the other switches and diodes can be wired directly to the LSI chip as per the two left-hand columns of table 3. All LSI chips including the DG-990 used in the CT-101-403 and MT-60 have the switch functions shown in this table except that in only the uPd-773 is position 3 1 a silent voice select - all the others make a sound with 3 1. Many Casiotones use a tunable clock oscillator consisting of a pot producing a variable voltage to drive a varicap diode, which forms a tuned circuit with an inductor to set the clock frequency. Feeding a voltage through a 4.7K resistor to the wiper of the pot gives you the possibility of frequency modulation over a small range. For wider FM I have developed a fairly linear VCO to run up to 2 MHz. I now possess a VL-1, VL-5, MT-30, M-10, CT-202 and MT-65.

\*\*\*\* STOP PRESS \*\*\*\* 19th April 1984 \*\*\*\*\*

I am partway through writing a new bulletin which deals with the MT-65 and other Casios which use the 931 sound LSI. I have figured out all the waveform definition parameters (apart from one mystery bit), and can now design my own Casio voices. I have developed a new DAC which is inherently free of glitches and makes the 931 sound perfect. This DAC is also applicable to the Series I Casios. Switches for "hardware" and "software" octave drops and transpose can be added. Coupling between instruments is relatively simple. I now have a slave 931 on a board external to the MT-65 and can load in MT-65 voices or my own voices from the computer. In short it is on for young and old! I hope to complete the new bulletin "The Casiotone Techzine" in the next few months. There are a whole new stack of Casios about to be released about which I know very little, this will mean a total of about 33 instruments in about three and a half years - a breakneck pace by any standards!

I can't give all the details of the deluxe CT-202 mods here, but these details along with the suggestions on page 9 will get you most of the way. TP-2 and TP-4 are the unfiltered 14 bit DAC outputs for left and right, while TP-7 is ground. The outputs of the filters are to be found on the front leads of resistors just to the right of 4558-17, closest to the 4558 is a 100k (left filter out) and to the right is a 47k (right filter out). Isolating pins 16 and 17 of each chip is easy and so is connecting the extra switches and diodes. Be sure to drive your switches from the common lines of the left LSI only. Connect the coupler via buffers to the left LSI. Each LSI has a pushbutton for voice select, a centre-off toggle (C&K T-103) for hard, none or soft vibrato, and toggles for slow vibrato, octave drop, hold and sustain. In addition to a filter bypass pot there is a toggle for slow instrument rate (hardware octave drop), and a "detune" switch which drives position 2 1 of the left LSI. This makes most of the left notes slightly different from the right which produces a wonderful chorus effect, particularly in stereo. Each LSI has over 40 different voices so there over 1600 possible hybrid voices, and zillions of combinations of voices and control switch settings. Although many of these differ only slightly from each other, a very wide range of sounds can nevertheless be produced. The modified CT-202 is a very fine instrument indeed especially when used in conjunction with external signal processing and EQ devices.

There are a few errors in the bulletin :- Page 2 - I am now 27 and my planned projects are progressing very slowly. Noriaki Shimura is not the managing director of Casio in Japan. Casio is controlled by the Kashio brothers, and Toshio Kashio is one who instigated the Casiotone instruments. In the future I will address my letters to him. Polyphony is 10 issues a year for \$12 US or \$14 foreign. The Contact List of Electronic Music (CLEM) is an international contact list of organisations, magazines, record labels, radio stations etc. involved in a wide range of independently produced music. Cost is \$2 in North America (check), or \$3 airmail elsewhere (money order). It is put together by Alex Douglas - P.O. Box 86010 North Vancouver, British Columbia V7L 4J5 Canada. Richard Wolton, rather than Richard Wilson of Texas first published a simple Set switch circuit for the M-10 in Nov/Dec 1980 issue of Polyphony. Serge Modular Music Systems have developed an eight channel 1V/Octave control voltage generator which together with a Series I Casio makes a very flexible mono or polyphonic controller for analog synthesis gear. Their address is 572 Haight St. San Francisco CA 94117 USA. So far I have sent this bulletin to 425 people and am covering costs.

The 220 ohm resistors are not needed in the Coupler circuit, I needed them because my prototype used faulty 74LS170s. The four timing components of the 74123 are connected as follows :- a 0.001 uf cap goes between pins 14 and 15 and between pins 6 and 7. A 27k is connected to pin 15 and another to pin 7, the other ends of these two resistors go to +5volts. There has been some confusion over the data connections of the 74LS170s. Pins 15, 1, 2 and 3 of A are connected to pins 15, 1, 2 and 3 of B. Likewise the pins 10, 9, 7 and 6 of A are connected to those pins of B. The same goes for C and D. To use the coupler purely for a computer to control the Casio, you can dispense with the 74123 and the two 74C08 ICs on the "Master" side and write directly into the 74LS170 twin-port RAM chips via an output port of your computer.

One interesting mod I have done to a few VL-5s is to make the one-key-play-key drivable from the +15v trigger of a TR-606 or TR-808 drum machine. This involves sending the trigger voltage through a 1k resistor to the LED of a darlington optocoupler, and using the optocoupler's pins 4 and 5 to close the switch position. The idea is applicable to other machines and has the advantage of total isolation between the trigger and the instrument. This is particularly important since the common of the output socket of the VL5 is connected to the +5V supply.

The Casio barcodes have aroused a lot of interest, and present a challenge to the Sherlock Holmes of the Data Domain. I have figured out the following :- Thick black lines or thick white spaces are ones, while thin black lines or thin white spaces are zeroes. Data is generally in four bit nybbles or eight bit bytes, with the most significant bits first. All lines start with a 0000010 start byte which is followed by a nybble which specifies what the line number is. The first line is 0000 and only on this one the line number is followed by a nybble which specifies the line type. Following this is a variable amount of data which is terminated by an end code which includes a checksum. The checksum is cumulative, so all the previous lines contribute to it. All lines except the last are filled to the right margin with dummy lines. I did not take the investigation any further, but Andrew Wood, of P.O. box C294, Clarence St NSW 2000 Australia, has done a thorough investigation of all the above including exactly how the data is represented and how the checksum is calculated. He has used the vertical bar character of an Itoh F-10 daisywheel to generate his own barcodes. You cannot generally use a felt tip pen to write your own barcodes because the ink is transparent to infra-red light, so you must photocopy your hand written codes first. The most practical approach to talking to your MT-70 etc. is to use your computer to drive an infra-red LED that shines into the magic wand, or plug into its socket and drive the MT-70 via an optocoupler. If you want to work in this field I suggest you write to Andrew Wood as his dossier (which was developed before he had heard of my work) is the definitive work on the matter.

As predicted, Casiotone modifications have moved into the data domain - header codes, protocols and checksums replace the simple switches and diodes of yesteryear. The MT-65 and CT-405 are carbon copies of each other - both use a single chip microcomputer to scan the keys and control switches, play chords, melody and bass and trigger drum sounds. This LSI talks to the upD931 sound LSI via 4 data lines and 2 strobe lines. Three nybbles are transferred in each burst. The turning on and off of notes, and the setting of vibrato and sustain modes is done in 1,2 or 3 bursts, but the voice specification takes about 98. The way in which waveforms and envelopes are specified is wierd and wonderful by any standards, and I have figured out 95% of what is going on. This means I am now the proud owner of a programmable MT-65! I am a long way off writing a nice interactive voice definition program however, and it would take me a while to document what I know so far. If you are a serious computer hacker and would like to know more about this then write to me. If you are inexperienced then give this area a miss - it really is very idiosyncratic.

Fig. 16 Instrument Rate Modification

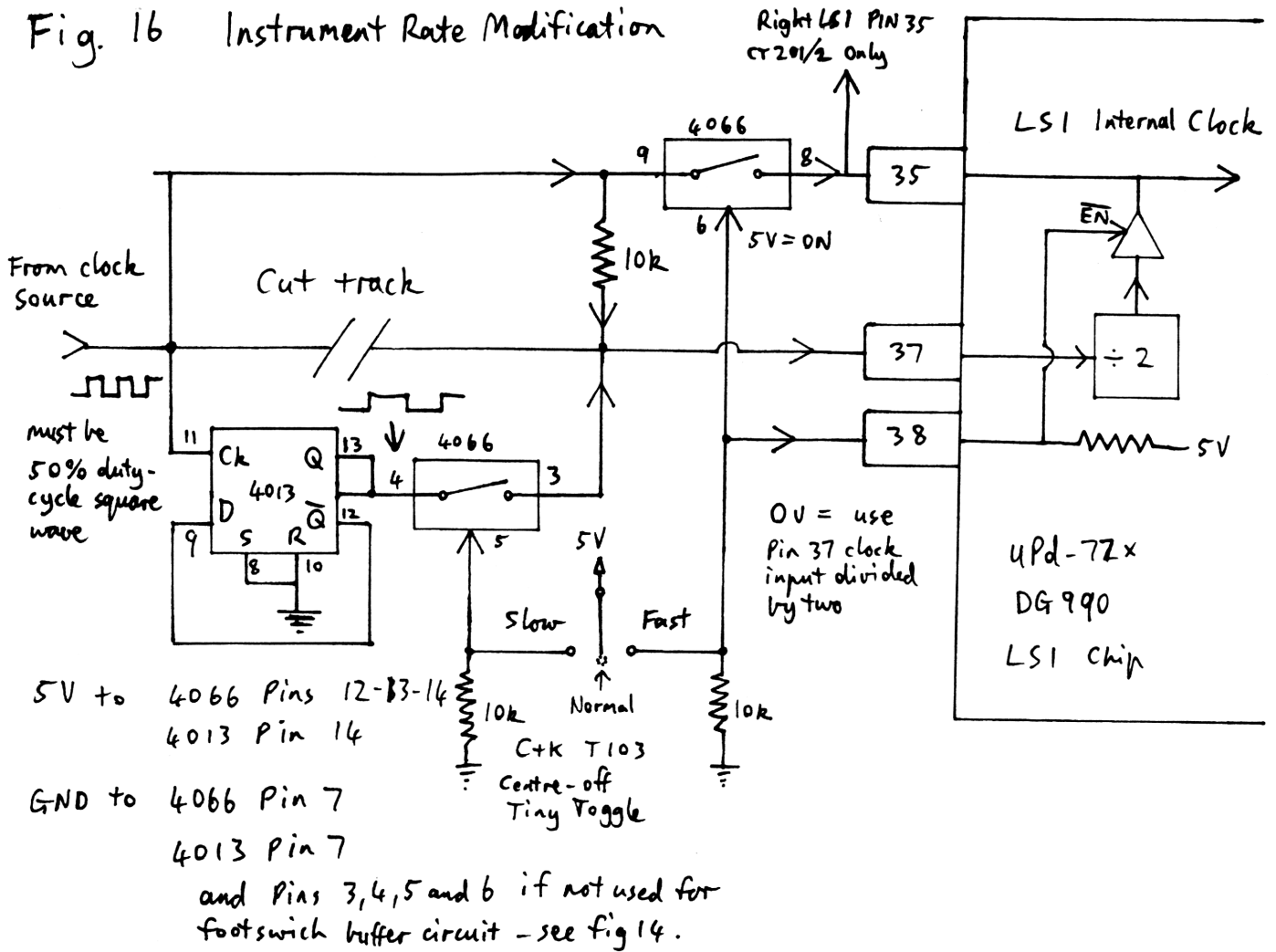
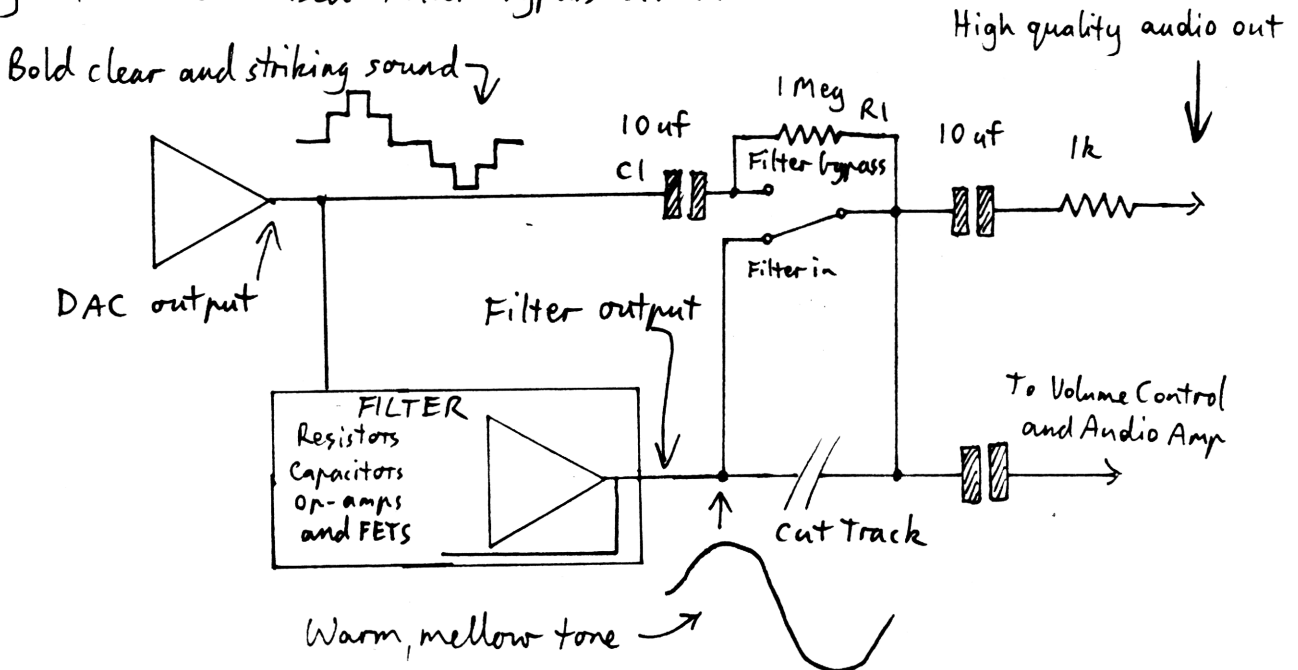
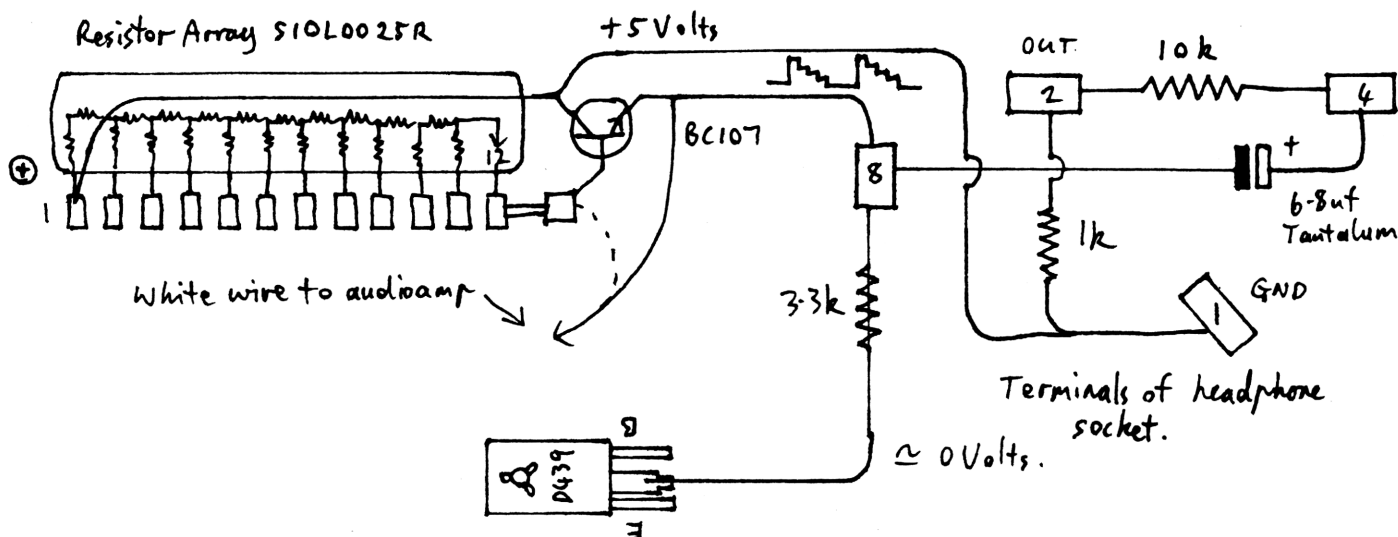

Fig 17 Generalised Filter bypass circuit



STOP PRESS !! David Cahill has just told me that he is substituting a 10K pot for the filter bypass switch so that it is possible to select any mixture of filtered and unfiltered sound. This seems like a very good idea, but placing the pot in the portable instruments could be quite troublesome.



The VL-5 uses a Hitachi LSI to drive the display and an NEC LSI to do everything else. Pin 31 is an analog rhythm output, while the keyboard sounds are fed through a 10 bit resistor array DAC. Since the audio amp is excessively noisy I have devised the above circuit to provide a clean unfiltered keyboard only signal from the headphone socket, so that a guitar lead can be used to connect the VL-5 to signal processing devices and amplifiers. First of all desolder all the wires from the socket, solder black (8) to purple (7) and yellow (4) to green (5) and tape them all up so they cannot short out. Desolder the white wire that connects the pad next to pin 12 of the resistor array to the audio board, solder the base of a BC-107 (or any other small NPN transistor) to the pad and solder the white wire to the emitter of the BC-107. A short length of wire connects the collector to pin 1 of the array and two longer lengths connect the collector and the emitter to pins 1 and 8 respectively of the socket. The VL-5 switches and regulates its negative supplies to conserve power, and the negative supply for the 3.3k load resistor of this emitter follower circuit comes from the collector of D439 which turns on the audio amp. The 3.3K and the other three components which decouple and attenuate the signal are mounted on the socket itself. Terminal 2 is the output and terminal 1 is the ground - since this is connected to the positive supply rail, the VL-5 must not share its external power supply with any other instrument.

In a last minute mercy decision, the VL-5 designers made it the first Casio instrument not to have a vibrato - if you wish to foil their good taste, connect a pushbutton switch and diode between pin 12 of the TC-4049BP-1 (cathode) and the long white jumper wire ②. Apart from an autostart for the rhythm there do not seem to be any other untapped features. Using a computer to drive an infra-red LED shining into the light pen would be a neat way to program the VL-5 if you could understand the bar-code. Since it obviously involves a rather sophisticated checksum system, I will not have time to figure it out but will be very interested to hear from anyone who makes any progress with this brain teaser. Technical details aside, the VL-5 is a great instrument - being able to play along with stored melodies opens several new approaches to music, the voices are quite interesting and the sound quality with the above mods is quite good enough for recording.