

How to use the

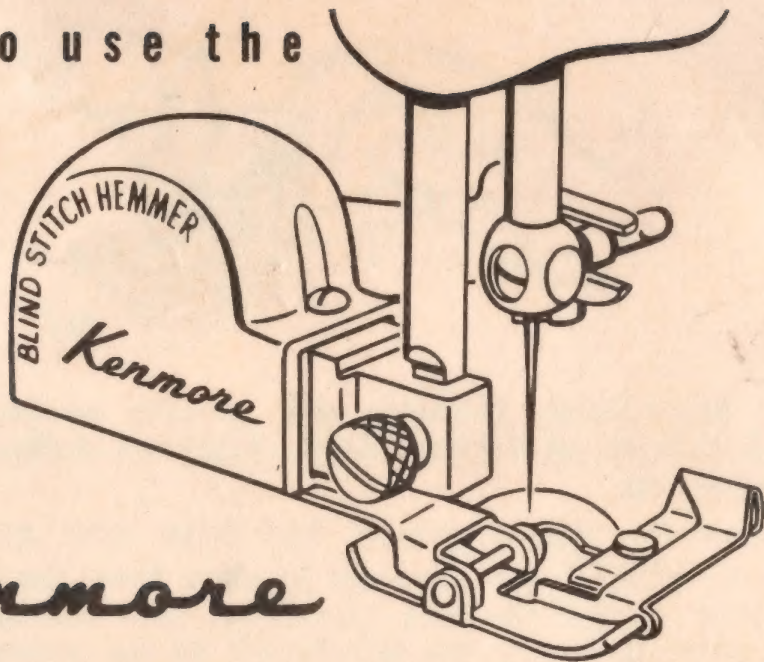

*Kenmore*

**BLIND-STITCH HEMMER**

# 1

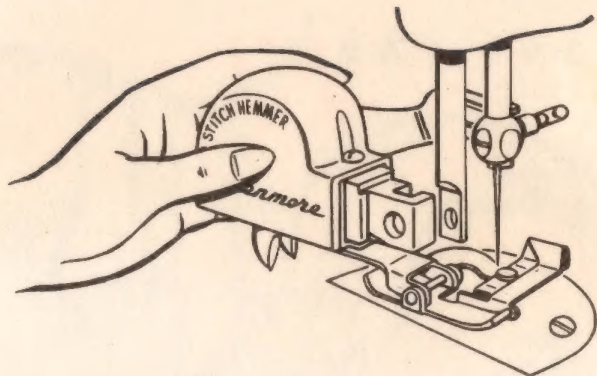

The Blind-Stitch Hemmer will quickly produce invisibly stitched hems on dresses, skirts, children's clothes, draperies, curtains, etc.

Remove the regular presser foot from your machine.

Slip the Blind-Stitch Hemmer in place from the back of the machine so that the fork arm is set over the needle clamp and securely fasten the attachment to the presser bar with the thumb screw using a screw driver.

© MITE Corporation 1961

# 2

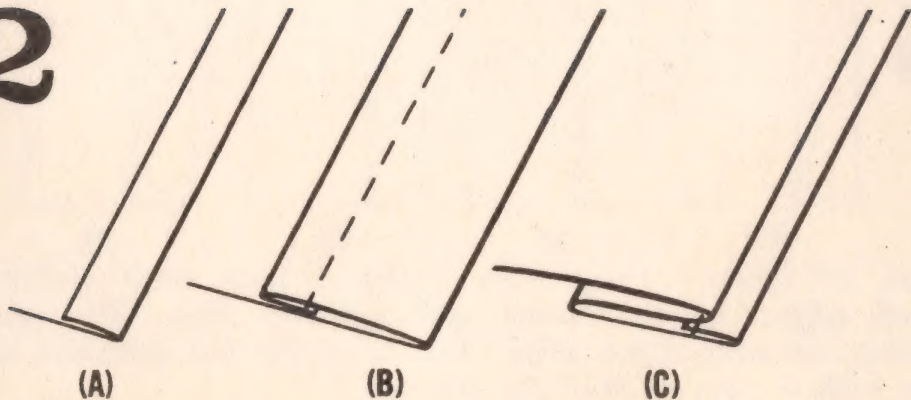

Prepare the garment in the same manner as for hand hemming.

(A) If hem with folded edge is used make first fold  $\frac{3}{8}$ " deep.

(B) Turn hem the depth desired and baste  $\frac{1}{4}$ " from upper edge of hem. Press.

(C) Fold hem back toward right side of garment leaving  $\frac{1}{4}$ " extended on hem.

# 3

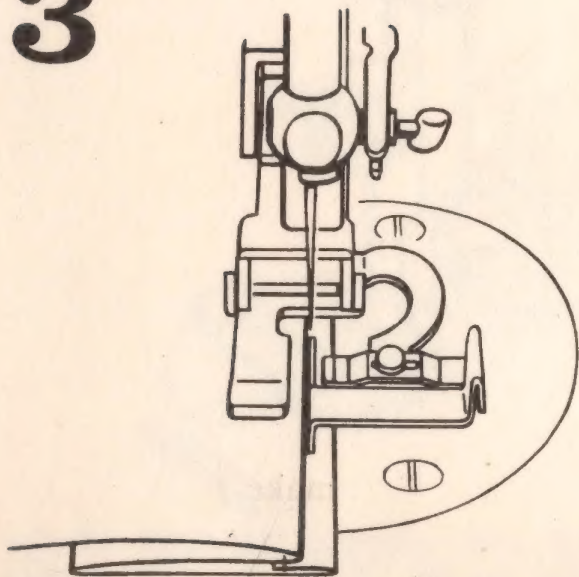

Place the hem under the foot with the edge of the fold against the guide (as shown). The attachment makes one sidewise tack every six stitches. The depth of the tacking is regulated by the adjustable guide on the right side of the foot. Adjust the guide according to weight of the fabric. Increase depth of tack for heavy fabrics. Decrease for light weight fabrics.

# 4

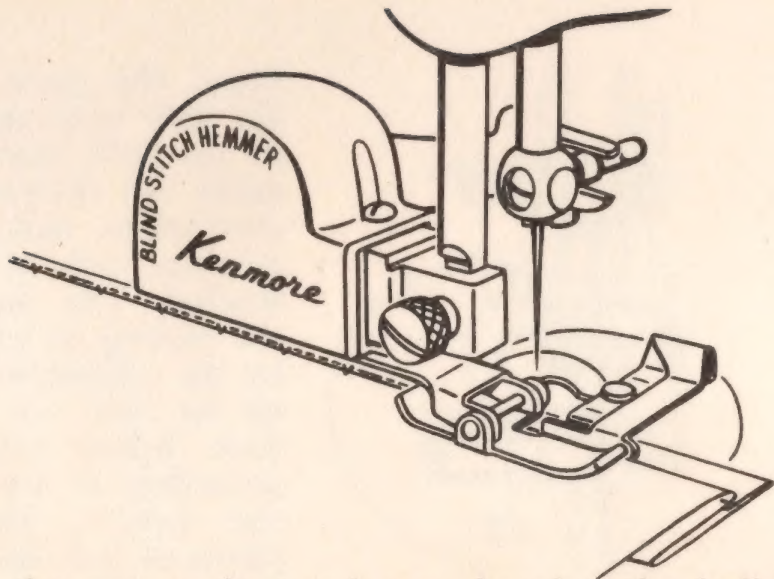

Lower the presser bar and sew, keeping the bulk of the garment to the left of the needle. With the fold firmly against the guide, stitch along the extended  $\frac{1}{4}$ ". Tacking or sidewise stitches will be made in the fold of the garment every six stitches.

# 5

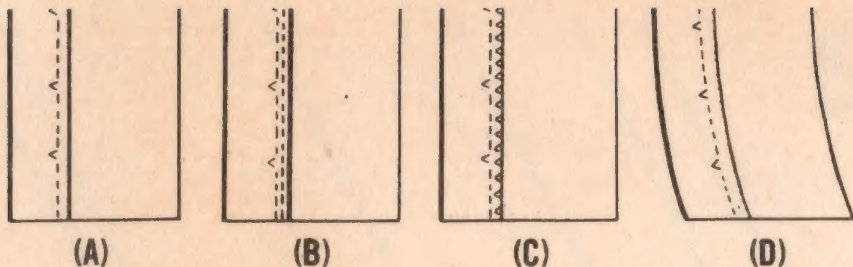

Types of Hems — You may make a hem with either a folded edge (A), a folded and stitched edge (B), seam binding, an overcast edge (C), or a cut (or pinked) raw edge with a row of straight stitches.

For Circular Hems (D) — Make a small hem in all circular skirts not more than 1" wide. Baste  $\frac{1}{4}$ " from the edge with a long machine stitch. Draw up the basting thread and distribute the fullness evenly until the hem lies flat on the wrong side. Then steam press out some of the fullness. Baste and blind hem as above.