

---

# User's Manual



# LX-800

---

**EPSON®**

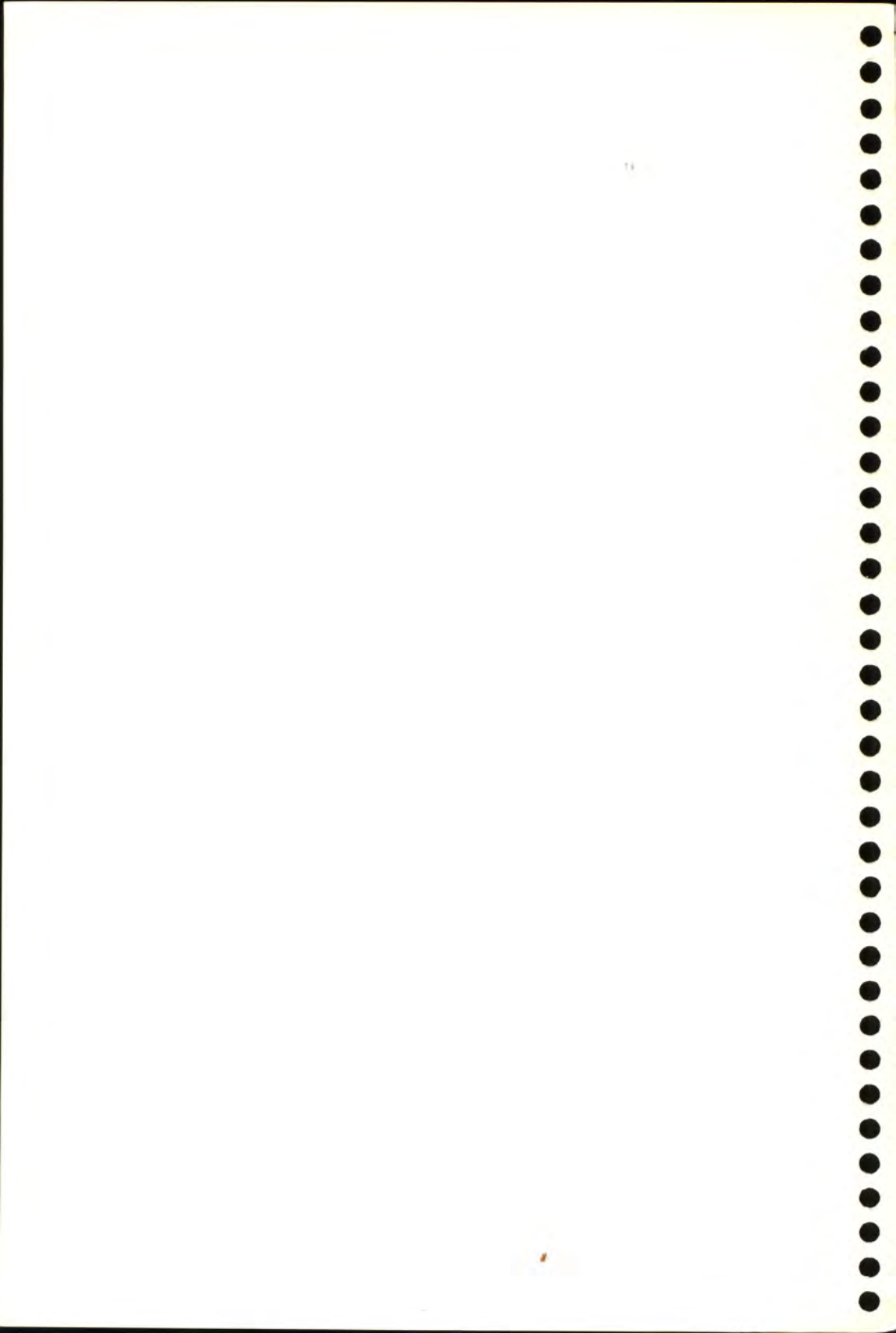

**EPSON<sup>®</sup>**  
**LX-800**

User's Manual

---

## FCC COMPLIANCE STATEMENT FOR AMERICAN USERS

This equipment generates and uses radio frequency energy and if not installed and used properly, that is, in strict accordance with the manufacturer's instructions, may cause interference to radio and television reception. It has been type tested and found to comply with the limits for a Class B computing device in accordance with the specifications in Subpart J of part 15 of FCC Rules, which are designed to provide reasonable protection against such interference in a residential installation. However, there is no guarantee that interference will not occur in a particular installation. If this equipment does cause interference to radio or television reception, which can be determined by turning the equipment off and on, the user is encouraged to try to correct the interference by one or more of the following measures:

- Reorient the receiving antenna
- Relocate the printer with respect to the receiver
- Plug the printer into a different outlet so that the printer and receiver are on different branch circuits.

If necessary, the user should consult the dealer or an experienced radio/television technician for additional suggestions. The user may find the following booklet prepared by the Federal Communications Commission helpful:

"Television Interference Handbook."

This booklet is available from the U.S. Government Printing Office, Washington, DC 20402. Stock No. 004-000-00450-7.

### WARNING

The connection of a non-shielded printer interface cable to this printer will invalidate the FCC Certification of this device and may cause interference levels which exceed the limits established by the FCC for this equipment. If this equipment has more than one interface connector, do not leave cables connected to unused interfaces.

All rights reserved. No part of this publication may be reproduced, stored in a retrieval system, or transmitted, in any form or by any means, mechanical, photocopying, recording or otherwise, without the prior written permission of Seiko Epson Corporation. No patent liability is assumed with respect to the use of the information contained herein. While every precaution has been taken in the preparation of this book, Seiko Epson Corporation assumes no responsibility for errors or omissions. Neither is any liability assumed for damages resulting from the use of the information contained herein.

Graphic on page 6-2 created with EPSON 3D-Graph.

Apple is a registered trademark and Applesoft is a trademark of Apple Computer, Inc.

Centronics is a registered trademark of Centronics Data Computer Corporation.

Epson is a registered trademark of Seiko Epson Corporation.

IBM is a registered trademark of International Business Machines Corporation.

Microsoft is a trademark of Microsoft Corporation.

Copyright © 1987 by Seiko Epson Corporation  
Nagano, Japan

---

# Contents

---

<b>Introduction</b> .....	1
LX-800 Features .....	1
About This Manual .....	2

---

## Chapter 1

### Setting Up

Identifying Printer Parts .....	1-1
Selecting a Place for the Printer .....	1-2
Installing the Paper Feed Knob .....	1-3
Installing the Ribbon .....	1-3
Replacing the Ribbon .....	1-6
Plugging in the Printer .....	1-7
Using Continuous-feed Paper .....	1-7
Using Single-sheet Paper .....	1-15
Operating the Control Panel .....	1-19
Connecting the LX-800 to Your Computer .....	1-23

---

## Chapter 2

### Using the LX-800 with Application Programs

Printer Selection Menus .....	2-1
Computer - Printer Communication .....	2-2
Word Processors .....	2-3
Spreadsheets .....	2-4
Graphics Programs .....	2-6
Programming Languages .....	2-6

---

## Chapter 3

### SelecType

SelecType Operation .....	3-1
SelecType Tips .....	3-3

## Chapter 4

---

### **LX-800 Printer Features**

Quality and Fonts .....	4-1
Print Size and Character Width .....	4-2
Special Effects and Emphasis .....	4-3
Using Different Character Sets .....	4-4
Page Layout and Other Commands .....	4-5

## Chapter 5

---

### **User-defined Characters**

Defining Your Own Characters .....	5-1
Designing Process .....	5-2
Defining NLQ Characters .....	5-7

## Chapter 6

---

### **Introduction to Dot Graphics**

The Print Head .....	6-2
Pin Labels .....	6-3
Graphics Commands .....	6-4
Simple Graphics Programming .....	6-6
Density Varieties .....	6-8
Designing Your Own Graphics .....	6-10

## Appendix A

---

### **Command Summary**

Commands in Numerical Order .....	A-4
Printer Operation .....	A-7
Data Control .....	A-10
Vertical/Horizontal Motion .....	A-11
Overall Printing Style .....	A-19
Print Size and Character Width .....	A-20
Print Enhancement .....	A-23
Word Processing .....	A-26
Character Sets .....	A-26
User-defined Characters .....	A-29
Graphics .....	A-30

## Appendix B

---

### **Character Tables**

International Character Sets .....	B-8
------------------------------------	-----

Appendix C

---

**Problem Solving and Maintenance**

Problem/Solution Summary .....	C-1
Beeper Error Warnings .....	C-4
Data Dump Mode .....	C-4
Coding Solutions .....	C-6
Solutions for Specific Systems .....	C-7
Maintaining Your Printer .....	C-9

Appendix D

---

**Defaults and DIP Switches**

Default and Initialization Settings .....	D-1
DIP Switch Settings .....	D-2
International Character Sets .....	D-3

Appendix E

---

**Choosing and Setting Up Optional Interfaces**

Compatible Interfaces .....	E-1
Choosing an Interface .....	E-1
Installing an Interface .....	E-2
Serial Interface Settings .....	E-8

Appendix F

---

**Technical Specifications**

Printing .....	F-1
Paper .....	F-1
Mechanical .....	F-2
Electrical .....	F-2
Environment .....	F-3
Parallel Interface .....	F-3
Data Transfer Sequence .....	F-5

---

<b>Index</b> .....	Index-1
--------------------	---------



---

## Introduction

The Epson LX-800 printer combines low price with high quality printing and advanced features.

---

### LX-800 Features

In addition to the high performance and reliability you've come to expect from Epson printers, the LX-800 offers the following:

- Draft mode for quick printing. The speed of draft printing is 150 characters per second in pica and 180 in elite.
- Near Letter Quality (NLQ) mode for top quality printing. When you have perfected a document, you can switch to one of two NLQ fonts—Roman or Sans Serif.
- A variety of print styles, including emphasized, double-strike, condensed, italic, and double-wide.
- Selection of typesyles with the control panel.
- User-definable characters so you can create and print your own symbols or characters.
- Dot graphics for charts, diagrams, and illustrations.
- Easy paper loading.
- A ribbon cassette for quick and clean ribbon changing.
- The Epson Character Graphics set, which includes character graphics that are used on IBM® and compatible computers as well as international characters used by IBM software.

---

## About This Manual

Chapter 1 gives you step-by-step instructions on setting up your new printer, and Chapters 2 through 6 cover the basic and advanced functions. The appendixes contain reference information, including all the details you need to use any of the printer's commands, and some advice on solving problems.

Inside the back of the manual is a pull-out Quick Reference card containing the information you need most.

# Chapter 1

---

## Setting Up

To set up your LX-800 printer, simply follow the steps in this chapter.

---

### Identifying Printer Parts

First, see that you have all the parts you need. In addition to this manual, the printer box should contain the items shown in Figure 1-1. The paper feed knob is packed into an indentation in the white foam material.

Figure 1-1:  
Printer parts

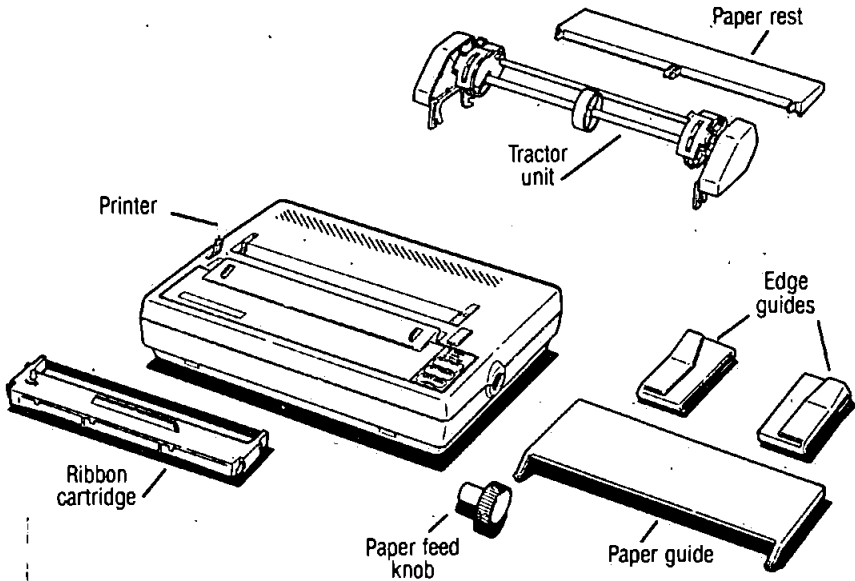

In addition to the items in the box, you need a proper shielded cable to connect the printer to your computer. You may also need an interface board, which is necessary only for those computers that can't use the Centronics® parallel interface. Your computer manual or your dealer can tell you which cable you need and whether or not you require a special interface.

---

## Selecting a Place for the Printer

The main consideration in selecting a good location for the printer is placing the printer close enough to your computer for the cable to reach. Also remember the following:

- Use a grounded outlet, and do not use an adapter plug.
- Avoid using electrical outlets that are controlled by wall switches. Accidentally turning off a switch can wipe out valuable information in your computer's memory and disrupt printing.
- Avoid using an outlet on the same circuit breaker with any large electrical machines or appliances. These can cause disruptive power fluctuations.
- Keep your printer and computer away from base units for cordless telephones.
- Protect the printer from direct sunlight, excessive heat, moisture, and dust. Make sure that it is not close to a heater or other heat source.

If you are going to use the tractor unit and continuous-feed paper, clear enough space around the printer so that the paper has an unobstructed path into and out of the printer. There are three common methods of arranging a printer and continuous-feed paper:

- Using a printer stand with the paper stacked behind it. (Because of the cable, it is usually best for the paper that feeds into the printer to be stacked somewhat behind the printer instead of directly beneath it.)
- Putting the printer on a desk or table and stacking the paper behind the printer.
- Using a desk or table as a stand, with the printer near the back edge and the paper on the floor or on a shelf.

---

## Installing the Paper Feed Knob

Now that you have decided where to locate your LX-800 printer, the first step in setting it up is installing the paper feed knob. Follow these steps:

1. Locate the paper feed knob, which is packed into an indentation in the white foam material:
2. Insert the knob into the hole on the right side of the printer, as shown in Figure 1-2. Gently rotate the knob until it fits over the shaft.

---

Figure 1-2.  
*Paper feed knob installation*

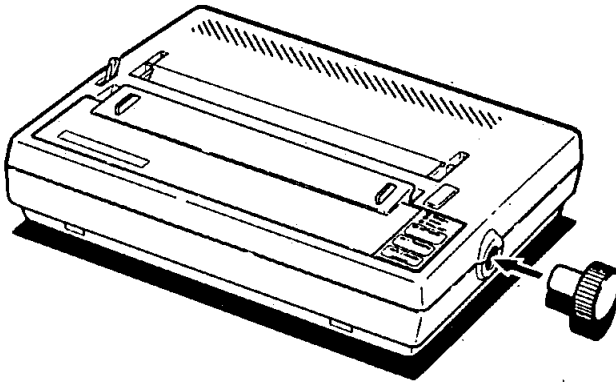

3. Push the knob in until it is flush with the printer case.

---

## Installing the Ribbon

The LX-800 printer uses a continuous-loop, inked fabric ribbon. It is enclosed in a cartridge that makes ribbon installation and replacement a clean and easy job.

To install the ribbon, follow these steps:

1. Remove the lid at the front of the printer by lifting the handles. Removing the lid enables you to see the print head, which is shown in Figure 1-3.

Figure 1-3.  
Print head

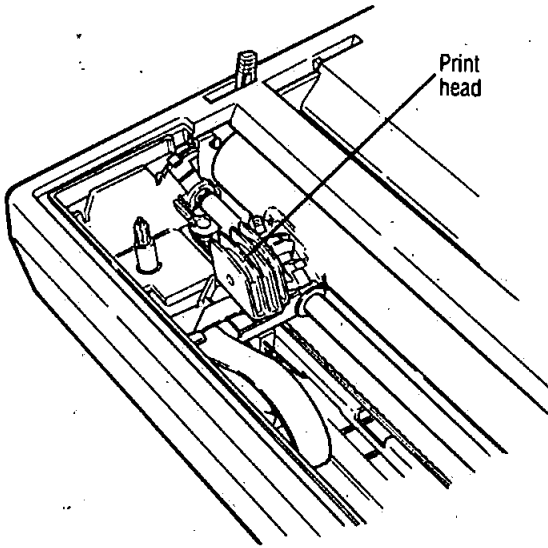

### Caution

The power must be off when you move the print head because moving the print head when the power is on may damage your printer. Also, if you've been using your printer, be careful not to touch the print head because it becomes hot during use. Let it cool for a few minutes.

2. Move the print head by hand to the center of the printer so that the other parts of the printer will not get in your way.
3. Grasp the ribbon cartridge by its handle and hold the cartridge so that the exposed strip of ribbon is facing away from you.

4. Insert the cartridge by placing the black hooks on each side of the cartridge into the slots located inside the printer in the right and left front corners. Push down until the cartridge snaps into place. (See Figure 1-4.)

Figure 1-4.  
Ribbon cartridge installation

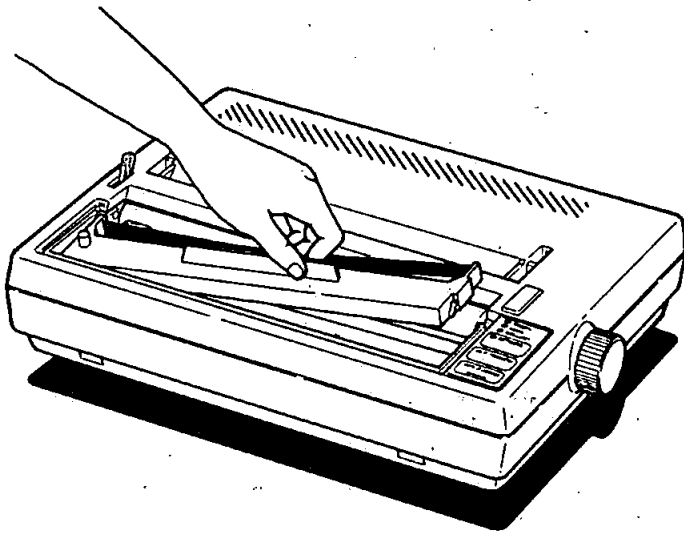

5. Turn the knob on the cartridge in the direction of the arrow to tighten the ribbon. As you turn the knob, see that the ribbon slips down into its proper place between the print head and the ribbon guide. (See the figure on the ribbon cartridge itself.) You may want to use a pencil to direct the ribbon, as shown in Figure 1-5.

Figure 1-5.  
Directing the ribbon

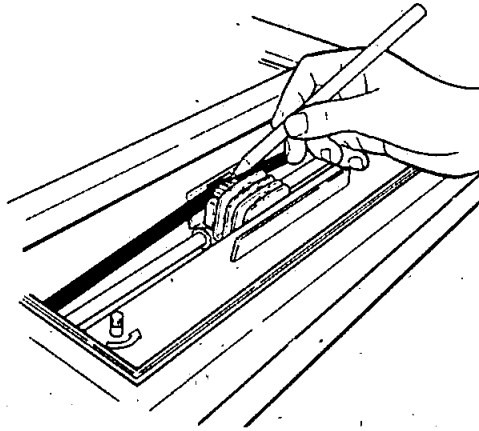

6. Replace the front lid by inserting its legs into the slots near the front corners of the printer. Lay the lid down.

---

## Replacing the Ribbon

When your printing becomes light and you need to replace the ribbon, follow these steps:

1. Remove the front lid.
2. Grasp the ribbon cartridge handle and pull out the cartridge.
3. Follow the ribbon installation instructions above to insert the new ribbon cartridge.

---

## Plugging in the Printer

Now plug in your LX-800. Make sure that the power switch on the left side of the printer is off before you plug in the printer.

---

## Using Continuous-feed Paper

The following section covers use of continuous-feed paper with your tractor unit. If you plan to use single-sheet paper, skip to the Using Single-sheet Paper section later in this chapter.

The tractor unit for the LX-800 allows you to use paper with pin feed holes along the sides (continuous-feed paper). You can adjust the tractor unit to accommodate widths of paper ranging from 4 to 10 inches, including the pin feed holes.

### Installing the tractor unit

You will need to install the tractor unit each time you wish to load continuous-feed paper after using single-sheet paper, which can only be loaded when the tractor unit is removed.

To install the tractor unit, follow these steps:

1. If the paper guide is installed, remove it by tipping it toward you and pulling it out.
2. Pop out the tractor unit slot cover, which is located above the indicator lights. It may help to use the flat edge of a screwdriver, as shown in Figure 1-6. Store the cover in a safe place while you use the tractor unit, and replace it when you remove the tractor unit.

Figure 1-6.  
Removing the tractor unit slot cover

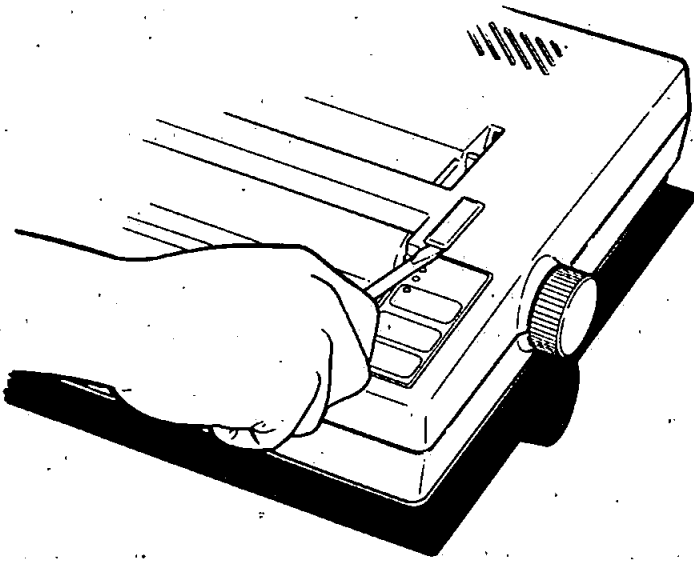

3. Fit the paper rest into the slots along the top edge of the back of the printer and snap it into place. See Figure 1-7.

Figure 1-7.  
Installing the paper rest

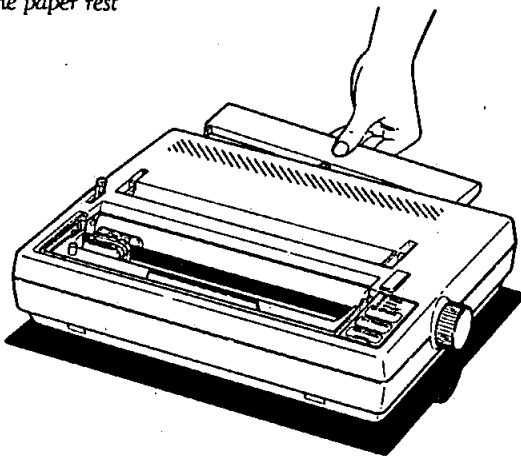

4. Pull the paper release lever forward. (See Figure 1-8.) The continuous-feed icon in front of the lever marks the position the lever should be in for using continuous-feed paper (or for releasing paper).
5. Now install the tractor unit. First, hold the unit so that its black legs are facing downward, as shown in Figure 1-8.

Figure 1-8.  
Preparing to install the tractor unit

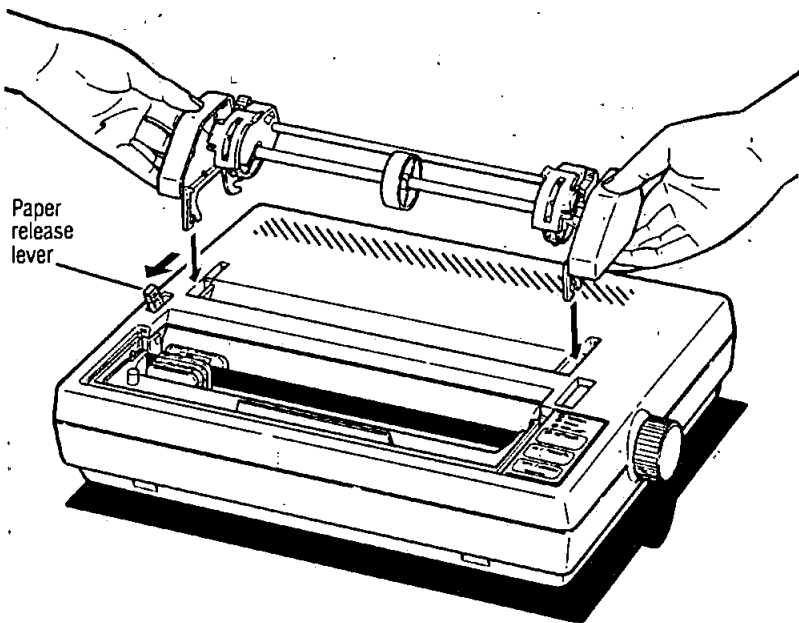

6. In each tractor slot, located at each side of the paper slot, is a peg that fits into the notch on each of the rear tractor legs. Tilt the tractor back so that the rear notches fit over these pegs. See Figure 1-9.

Figure 1-9.  
*Installing the tractor unit*

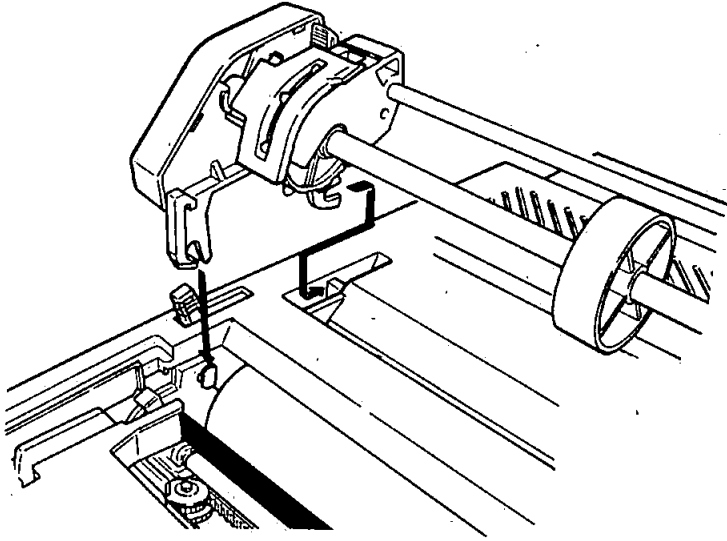

7. Then tilt the unit forward until the front legs snap into place.

### **Loading continuous-feed paper**

Once the tractor unit is installed, load continuous-feed paper as follows:

1. Make sure that the printer is turned off.
2. Remove the front lid of the printer.
3. Move the print head to the center of the printer. Remember, the printer must be turned off whenever you move the print head. Also, if you've been using the printer, the print head may be hot. Be careful not to touch it unless you let it cool for a few minutes.

4. Using Figure 1-10 as a guide, pull the locking levers on each side of the pin feed holders forward so you can move the pin feed holders.

Figure 1-10.  
*Locking lever for pin feed holder adjustment*

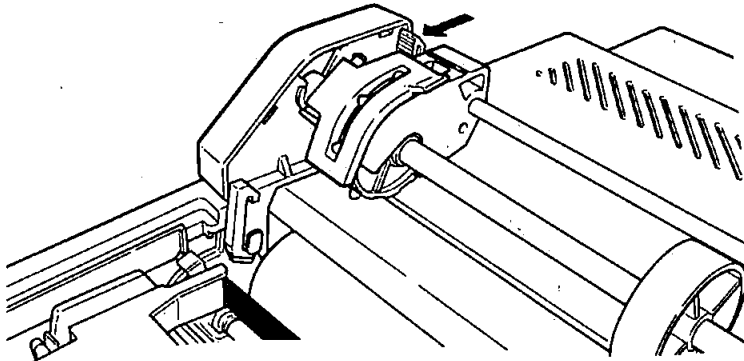

5. Place the left holder approximately  $3/4$  of an inch from the far left position and then push the locking lever back to fasten that holder into place. Leave the other holder unlocked.
6. Open the pin feed covers as shown in Figure 1-11.

Figure 1-11.  
*Opening the pin feed covers*

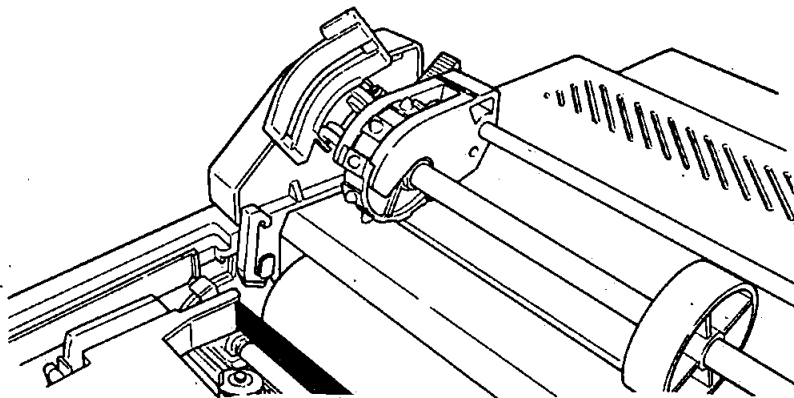

7. Feed the paper into the paper slot. Push and maneuver the paper through the slot until it comes up between the ribbon guide and the platen.
8. Pull the paper up until the top is above the pin feed holders. Fit the holes along the left edge of the paper over the pins in the left holder, as shown in Figure 1-12, and close the pin feed cover.

Figure 1-12:  
Fitting the paper into the left pin feed holder

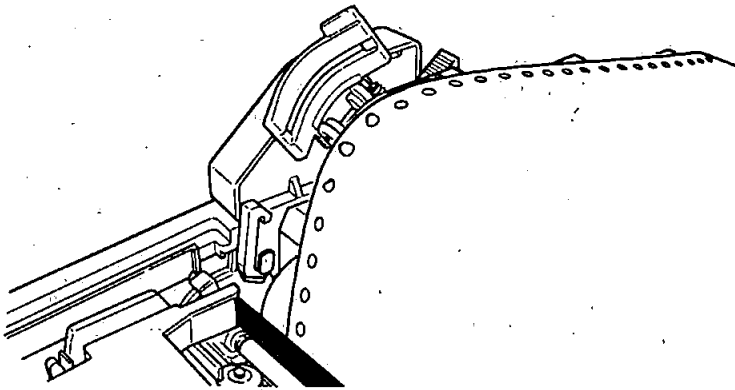

9. Fit the right side of the paper into the right holder, moving the holder as needed to match the width of the paper. Close the second pin feed cover.
10. Make sure that the paper has no dips or wrinkles, then push the locking lever back to lock the right holder in place.

### Installing the paper guide

Install the paper guide, which is used here as a paper separator, as described below. Note that the guide is installed in one of two different positions depending on the type of paper you use. It lies flat when you use continuous-feed paper, as described here, and sits upright for loading single-sheet paper.

1. If the edge guides are not yet in place, install them by hooking the tab on the back of each guide over the top of the paper guide, as shown in Figure 1-13. Snap the bottom of each guide into place.

For continuous-feed paper, move the edge guides to the far right and left positions on the paper guide. You won't be inserting paper through the edge guides unless you use single-sheet paper.

Figure 1-13.  
Installing the edge guides

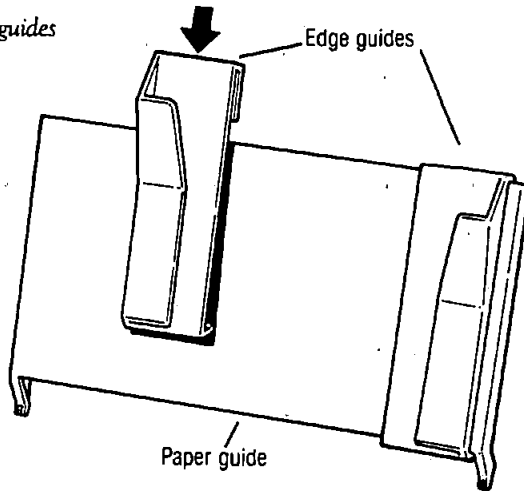

2. Insert the legs of the paper guide into the slots behind the tractor unit, keeping the guide tilted backward as you do so. (See Figure 1-14.)

Figure 1-14.  
Installing the paper guide

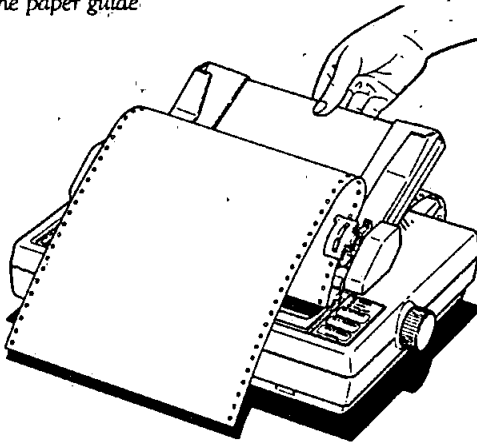

3. When the legs are in the slots, lean the guide all the way back. The guide should rest atop the paper entering the printer, separating it from paper exiting the printer.

### Setting top of form

Now you are ready to set the top of form position. Follow these steps:

1. Turn the paper feed knob to advance the paper until a perforation between pages is just below the top of the ribbon.
2. Now replace the front lid.

Your printer should now be set up as shown in Figure 1-15.

Figure 1-15.

*The printer with continuous-feed paper*

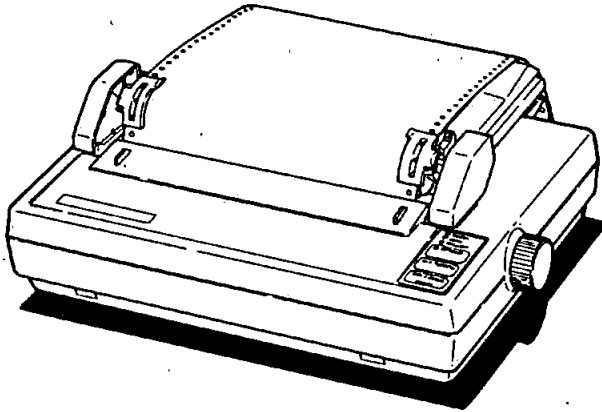

When you turn on your LX-800, it remembers this top of form setting and uses it when any program tells it to move to the top of the next page. If you later find that your word processing or other application program prints too high or too low on the page or is printing on the perforations, check to see that your top of form setting is correct.

Once you have set the top of form, each time you finish printing a document, push the **ON/OFF LINE** button to put the printer off-line and then push the **FORM FEED** button once to advance the paper one sheet. This enables you to tear off your just-printed pages and leave the paper in the correct position to begin the next document.

### **Removing the tractor unit**

It is necessary to remove the tractor unit before you use single-sheet paper. To remove the unit, follow these steps:

1. Remove the front lid.
2. Open the pin feed covers and pull the paper off the pins. Then lay the paper over the front of the printer so you can reach the tractor feed unit.
3. Grasp both sides of the tractor unit and gently lift up the front end. This action unsnaps the front legs of the tractor unit and enables you to lift off the unit.
4. Pull the paper guide toward you until it settles into an upright position for single-sheet paper.
5. Make sure that the paper release lever is forward, and remove the paper.
6. Replace the front lid.

---

### **Using Single-sheet Paper**

The automatic loading feature handles individual sheets quickly and easily.

Before you load single-sheet paper, you must prepare the printer by installing the paper guide in an upright position. If the tractor unit is installed, remove it by following the above instructions. After following those instructions, you can skip the following section on paper guide installation, except for step 3 on aligning the left edge guide.

## Installing the paper guide

Install the paper guide as follows:

1. If you have not already done so, install the edge guides on the paper guide by hooking the tab on the back of each guide over the top of the paper guide, as shown in Figure 1-13. Snap the bottom of each edge guide into place.
2. Hold the paper guide so that it is in an upright position. Then insert the legs of the guide into the slots on either side of the printer behind the paper slot, as shown in Figure 1-16.

Figure 1-16.

Installing the paper guide

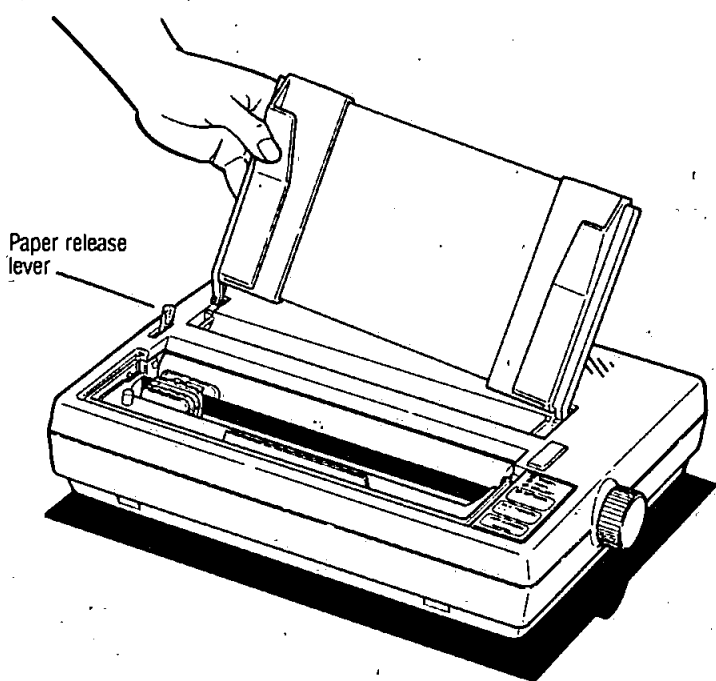

3. Align the left side of the left edge guide with the guide mark on the paper guide. See Figure 1-17. You may later wish to adjust this edge guide depending on the margin setting in your application program.

Figure 1-17.  
Guide mark for paper alignment

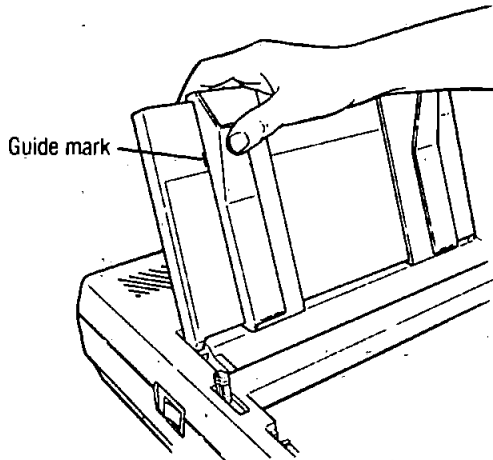

### Automatic paper loading

Now you are ready to load single-sheet paper using the LX-800's AUTO LOAD feature.

To load paper automatically, just follow these steps:

1. Push back the paper release lever. (See Figure 1-16.) The single-sheet icon behind the lever marks the position the lever should be in for loading single-sheet paper.
2. Turn on the printer.
3. Make sure that the ON LINE indicator is off. If it is not off, press the touch-sensitive panel labeled ON/OFF LINE.
4. Adjust the right edge guide to fit the size of the paper.
5. Slide the paper down through the edge guides until it meets resistance. Press down on the paper a bit more to make sure that it is firmly in place, as shown in Figure 1-18.

Figure 1-18.

LX-800 ready for automatic paper loading

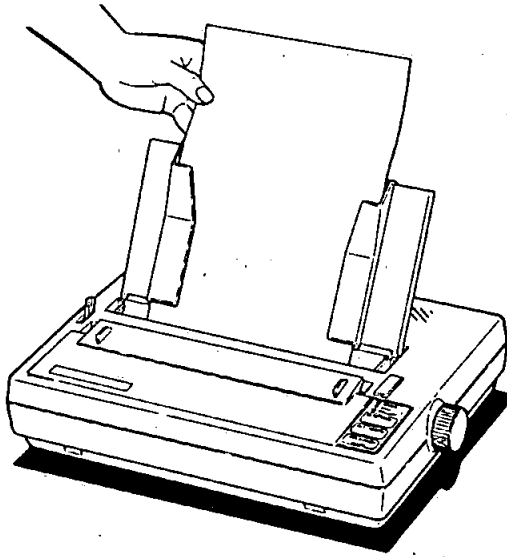

6. Press and release the AUTO LOAD button (the same button as the DRAFT/LINE FEED button). The paper is automatically loaded to the top of the page.
7. Push the ON/OFF LINE button so that the printer is ready to accept data.

---

**Note**

With single-sheet paper, make sure the front lid is in place whenever you print. (Always snap the lid shut when replacing the lid.) The front lid functions as a paper bail for single-sheet paper by holding the paper against the platen.

8. If the paper is crooked and needs to be reloaded, pull the paper release lever forward, pull out the paper, push the lever back, turn the printer off, and reload by beginning again at step 1 in the Automatic paper loading section above. If the paper just requires minor adjustment, then pull the paper release lever forward, open the front lid, adjust the paper, and push the lever back. Then close the front lid.

## Reloading during printing

When you print a document more than one page long using single-sheet paper, there are two ways your software can enable you to load a new sheet at the end of a page:

- If your software sends characters in a continuous stream, the printer stops printing when it reaches the bottom of the paper. When this happens, the ON LINE light goes off automatically.
- If your software handles printing page by page, it probably stops sending characters at the end of a page and prompts you to insert more paper. In this case, the ON LINE light may remain on. If it does, the first thing you should do is press the ON/OFF LINE button once to turn it off.

Once the ON LINE light is off, remove the sheet that has just been printed and load a new sheet in the same way as before.

## Printing multi-part forms and copies

If you wish to print multi-part forms or carbon copies, use no more than three sheets or parts at a time, with a total thickness of no more than 0.01 inches. The factory setting for the paper thickness lever, located inside the front lid on the left side, accommodates both single sheets and multiple forms. There is no need to adjust the lever.

---

## Operating the Control Panel

Now that your paper is loaded, it is time to see what the indicators and buttons on the control panel do. First, see that the power switch on the left side of the printer is on. Then take a look at the control panel. (See Figure 1-19.)

Figure 1-19.  
Control panel

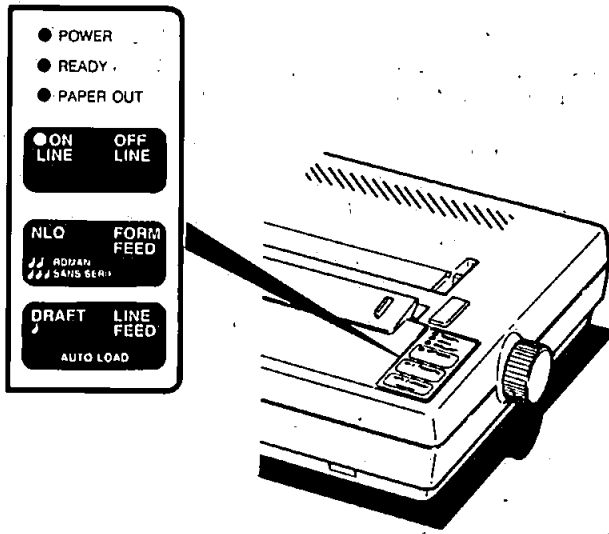

There are four indicator lights and three buttons on the control panel.

### Indicator lights

The indicator lights give you information on the printer's status:

- The POWER light glows green when the power is on.
- The READY light glows green when the printer is ready to receive data. This light flickers somewhat during printing.
- The PAPER OUT light glows red to indicate that the printer is out of paper or the paper is loaded incorrectly. If you try to print and the printer does not respond, check to see if this light is on.
- The ON LINE light glows green when the printer can receive data. (The ON LINE light is located on the ON/OFF LINE button.)

### Buttons

The buttons, or touch-sensitive panels, have several functions, including selecting draft or NLQ (Near Letter Quality) printing. Draft is good for quick printing of ordinary work, and NLQ has more

fully-formed characters for final copies or special purposes. NLQ is available in both Roman and Sans Serif fonts.

The printout below shows the differences among draft, NLQ Roman, and NLQ Sans Serif so that you can compare the different styles and densities:

Draft printing is extremely fast.  
NLQ Roman is clear and typewriter-like.  
NLQ Sans Serif is crisp and distinctive.

See Chapter 4 for more information on these modes and ways to select them.

- **ON/OFF LINE.** This button switches the printer between on line and off line status.
- **NLQ/FORM FEED.** When the printer is off line, pressing this button advances continuous-feed paper to the top of the next form or ejects a single sheet. When the printer is on line, pressing this button selects NLQ (Near Letter Quality) printing.

Pressing the **FORM FEED** button when the printer is **ON LINE** alternates the NLQ font between Roman and Sans Serif. When NLQ Roman is selected, the beeper sounds twice. When NLQ Sans Serif is selected, the beeper sounds three times.

- **DRAFT/LINE FEED.** When the printer is off line, pressing this button advances the paper one line. When the printer is on line, pressing this button selects draft printing. When you select draft printing the beeper sounds once. This button also controls the **AUTO LOAD** feature.

The control panel buttons also control the **SelecType** feature. This feature enables you to select among emphasized, double-strike, condensed, and elite typesyles. See Chapter 3 for more information.

### Performing self test

Now you'll see your LX-800 print something even though it's not yet connected to a computer. Follow these steps:

1. Make sure that your printer has paper in it.

2. Turn the power switch off, then hold down the DRAFT button on the control panel while you turn the power back on. The LX-800 begins printing letters, numbers, and other characters that are stored in its ROM (Read Only Memory) in draft mode. (If DIP switch 1-5 has been turned on, the test will be performed in NLQ mode, as in step 4 below.)
3. When printing starts, you can release the DRAFT button; the printing continues until you turn the printer off or until the printer runs out of paper.
4. To perform the same test in the NLQ mode, load another sheet of paper. Turn the printer off, then turn it back on while holding down the NLQ button. Sans Serif and Roman fonts alternate for this test. Partial results of both tests are shown in Figure 1-20.

Figure 1-20.  
Test patterns

#### DRAFT

```
'()*+,-./0123456789:;<=>?@ABCDEFGHIJKLMNO
()'+,-./0123456789:;<=>?@ABCDEFGHIJKLMNO
)'*+,-./0123456789:;<=>?@ABCDEFGHIJKLMNO
)*+,-./0123456789:;<=>?@ABCDEFGHIJKLMNO
+,-./0123456789:;<=>?@ABCDEFGHIJKLMNO
*+,-./0123456789:;<=>?@ABCDEFGHIJKLMNO
+,-./0123456789:;<=>?@ABCDEFGHIJKLMNO
-./0123456789:;<=>?@ABCDEFGHIJKLMNO
./0123456789:;<=>?@ABCDEFGHIJKLMNO
PQRSTUVWXYZ
/0123456789:;<=>?@ABCDEFGHIJKLMNO
PQRSTUVWXYZV
```

#### NLQ

```
'()*+,-./0123456789:;<=>?@ABCDEFGHIJKLMNO
()'+,-./0123456789:;<=>?@ABCDEFGHIJKLMNO
)'*+,-./0123456789:;<=>?@ABCDEFGHIJKLMNO
)*+,-./0123456789:;<=>?@ABCDEFGHIJKLMNO
+,-./0123456789:;<=>?@ABCDEFGHIJKLMNO
*+,-./0123456789:;<=>?@ABCDEFGHIJKLMNO
+,-./0123456789:;<=>?@ABCDEFGHIJKLMNO
-./0123456789:;<=>?@ABCDEFGHIJKLMNO
./0123456789:;<=>?@ABCDEFGHIJKLMNO
PQRSTUVWXYZ
/0123456789:;<=>?@ABCDEFGHIJKLMNO
PQRSTUVWXYZV
```

---

## Connecting the LX-800 to Your Computer

Now that the test pattern has shown that your printer is operational, it's time to hook it up to your computer.

Remember that computer systems communicate with printers in a variety of ways. If your computer expects to communicate through a Centronics parallel interface, all you need is the proper shielded cable. If your computer requires any other kind of interface, you also need an interface board.

If you don't know what a Centronics parallel interface is, your computer manual or your dealer can tell you what you need. Then, once you have plugged your printer cable into your printer and computer, you will probably never think about interfaces again. (If you do want the technical specifications, however, you can find them in Appendix F.)

Follow these steps and refer to Figure 1-21 to connect your printer and computer:

1. Make sure that both your printer and computer are turned off.
2. Plug the appropriate end of your printer cable into the cable connector of your LX-800 printer. The plug is shaped so it fits the connector only one way.

---

Figure 1-21.  
*Cable connection*

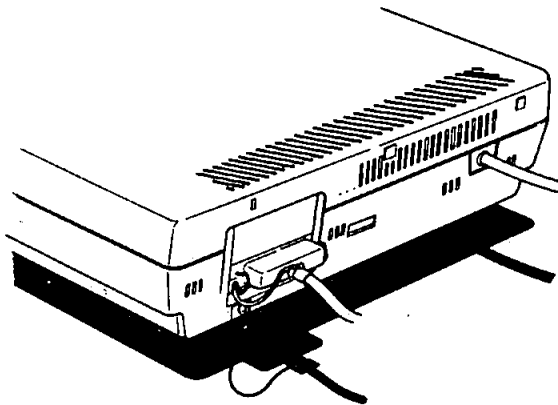

3. Secure the plug to the printer with the wire clips on each side of the connector. Press the clips into the metal clasps at each side of the plug. These clips ensure that your cable will not be loosened or unplugged accidentally.
4. If your cable has a grounding wire, fasten it to the grounding screw below the connector.
5. Connect the other end of the printer cable to your computer. On most computers you can easily find the correct connector for the printer cable, but if you are not sure, consult your computer manual or your dealer.

## Chapter 2

---

# Using the LX-800 with Application Programs

Now that you've set up and tested the printer, you need to start using it with your application programs.

---

## Printer Selection Menus

Most application programs let you specify the type of printer you're using so that the program can take full advantage of the printer's features. Many programs provide an installation or setup procedure that presents a list of printers to choose from. If your application program has a printer selection menu, use the instructions below.

The rest of this chapter covers word processors, spreadsheets, graphics programs, and programming languages.

### Menu selections

If your software has a printer selection menu, simply choose LX-800. If the menu does not list this printer, choose one of the following. They are listed in order of preference.

- FX-86e
- EX-800
- LX-86
- LX-80
- FX-85
- FX-80
- RX-80
- Epson printer
- Draft printer

---

### Note

If your application program does not list the LX-800, you may want to contact the manufacturer to find out whether an update is available.

---

### **A quick test**

After setting up your application program, print a sample document to be sure the program and the LX-800 are communicating properly. If the document doesn't print correctly, recheck the program's printer selection and installation procedure. If you're still having trouble printing, consult Appendix C.

---

## **Computer – Printer Communication**

Computers and printers communicate by using codes to represent characters and commands. To be sure the two devices use the same codes, almost all manufacturers of computers, printers, and software use the American Standard Code for Information Interchange, which is usually referred to by its abbreviation, ASCII.

The ASCII standard includes codes for printable characters (letters, punctuation marks, numerals, and mathematical symbols) and 33 other codes called control codes. The control codes are for such functions as sounding the beeper and performing carriage returns. Because the 33 control codes are not enough to control all possible printer functions, most printer commands are actually a sequence of two or more codes.

One of the 33 control codes, the escape code, signals the beginning of a sequence of codes. Therefore, most printer commands are sequences of codes, the first of which is the escape code. This manual uses the ASCII abbreviation ESC for this code.

When using control codes to select printer functions for an application program or programming language, check the manual for the program or language to find the appropriate method of inserting the code into the program. Further details on the methods to use are in the rest of this chapter.

### **Naming and using commands**

The most common way of naming codes or commands is with one of two numbering systems, decimal or hexadecimal.

The decimal system is the standard numbering system based on units of ten, using the numerals 0-9.

The hexadecimal, or hex, system is based on units of 16 and is often used by programmers. Instead of using only the numerals 0 through 9, the hex system also uses the letters A through F. For example, the decimal numbers 9, 10, 11, and 12 are 09, 0A, 0B, and 0C in hex.

Since the most frequently used hexadecimal numbers are between 0 and FF hex (0 to 255 in decimal), it's common to write hexadecimal numbers that are less than 16 with a zero in front, as shown above.

In this book, hex numbers are distinguished from decimal numbers by the word hex after them (for example, 1B hex). Other common ways of denoting a hexadecimal number are the following:

1BH   \$1B   &1B   &H1B   <1B>H

The Command Summary and the Quick Reference card give both the decimal and hex numbers for each command.

---

## Word Processors

In many ways, word processors demand the most from your printer. When you create and print a document, you may use many print styles and fonts, add headers and footers, and use bold, italic, and other effects.

Once you have installed your word processor by using the lists on page 2-1, you can ordinarily use a fixed set of printer features by using a word processor command to place markers around the text to be altered. When the document is printed, the markers are recognized and translated into suitable commands for your printer. On your screen some programs show the markers; others display the text as it will appear—for example, in bold or italics.

This method is normally restricted to features that can be found on almost all printers, such as bold and underlining.

Some programs also provide a way of placing complete printer commands in the text. These commands may or may not be visible on your screen. This method has the advantage of allowing you to use any printer command, not just a limited set. To make use of it, however, you need to understand how to use the printer's commands.

Check the manual for your word processor to see if you can place printer commands in your text. If this is possible, use the Command Summary (Appendix A) in this manual to find the command, and use the manual for your word processor to find how to assign the command.

If your LX-800 is not printing correctly, check both the printer and your word processor and do the following:

- Make sure you've selected the correct printer.
- Carefully read the printer setup and installation information in your word processor's manual.
- Check the printer options that may be part of the installation or setup section (line feeds, interface, etc.).
- Make sure your word processor is capable of sending the proper commands to your printer.

If you're still having difficulty printing, check the troubleshooting section in your word processor's manual and Appendix C of this manual.

---

## Spreadsheets

Although spreadsheets seldom use as many printing styles as word processors, they do have some very specific requirements.

### Installation and column width

If your spreadsheet program provides a list of printers, use the list on page 2-1 to find the proper selection. If your spreadsheet doesn't have a printer setup routine, carefully read the program's manual for information on printing.

A major concern for printing spreadsheets is the width of the printer. The LX-800 is an 80-column printer, but you can increase the number of characters on a line by using one of the modes in Table 2-1. You can turn on elite, condensed, and condensed elite using buttons on the control panel (see SelecType in Chapter 3). See Chapter 4 for information on other methods for selecting these modes.

Table 2-1. Characters per line

Normal	80
Elite	96
Condensed	132
Condensed Elite	160

Therefore, if your spreadsheet asks the number of columns your printer can print, decide which mode you will use and supply the appropriate number from Table 2-1.

### Printer commands

Unlike word processors, spreadsheet programs usually don't let you change printer commands within a spreadsheet. Instead, one style or mode of printing is used for the whole spreadsheet. With the LX-800, there are two main ways of sending commands to control the printing of a spreadsheet.

First, almost all spreadsheets have the capability of sending commands to a printer. Look in the manual for your spreadsheet to find out how to send printer commands. Then look in the Command Summary (Appendix A) in this manual to find the proper codes to send.

For example, your spreadsheet might use a "setup string" to send printer commands. To prepare a setup string for condensed elite, you would look up the proper command in the Command Summary.

The command for elite is ESC M, and the command for condensed is SI. Because most spreadsheets use the decimal equivalent for the commands, (also given in the Command Summary), a setup string for condensed elite might look like this:

`/027/077/015`

The number 027 is for the escape code, 077 is for M, and 015 is for SI (condensed).

The second method to choose condensed is one of the Selectype control panel buttons. The use of these buttons is described in Chapter 3.

If your spreadsheet is not printing correctly, be sure you have selected the correct printer if the program asks you to select one.

If you're using the program's print facility, recheck the Command Summary to make sure you're sending the correct commands.

If you're still having difficulty printing, check the troubleshooting section in your spreadsheet program's manual or Appendix C of this manual.

---

## Graphics Programs

The LX-800 is capable of producing finely detailed graphic images. Although Chapter 6 gives specific information on the graphics commands, the easiest way to take advantage of the LX-800's capabilities is with one of the many graphics programs available.

When buying graphics software, always make sure it has a suitable option to allow printouts on an LX, EX, or FX printer. Any program with an option for one of these printers should give excellent results, using different dot densities to produce a realistic scale of grays.

Most graphics programs have a printer selection procedure, in which case you should check the list on page 2-1 to find the proper selection.

---

## Programming Languages

Most users rely on application programs to send commands to the printer. An awareness of programming languages, however, can be helpful in exploring a printer's potential or troubleshooting a printing problem.

For example, if you want to set up your application program to send a command for italic printing, you can use a programming language, such as BASIC or Pascal, to do a quick printout before setting up the program.

If, on the other hand, you've set up a program to send a certain command to the printer, but it's not printing correctly, you can send the same command with a programming language to find whether the problem lies with your application program, the command, or the printer.

## Sending printer commands with BASIC

You can send printer commands with any programming language. The examples in this manual are written in BASIC, because BASIC is included with most computer systems.

In most forms of BASIC, and in particular Microsoft™ BASIC, the normal method of producing printed output is to use the LPRINT statement followed by the text to be printed enclosed in quotation marks, as shown below:

```
100 LPRINT "This text will be printed."
```

Individual printer control codes can be sent by using the CHR\$ function with the LPRINT statement:

```
110 LPRINT CHR$(27);CHR$(69);
```

This line sends ASCII codes 27 and 69 to the printer, selecting emphasized printing.

Most versions of BASIC permit the ASCII codes in the CHR\$ function to be given in either decimal (as above) or hexadecimal. Also, if the code corresponds to a printable character, the character itself can be used in quotation marks in the LPRINT statement. The command shown above could therefore be given in two other forms:

```
LPRINT CHR$(27);"E"  
LPRINT CHR$(&H1B);CHR$(&H45)
```

As you can see, Microsoft BASIC uses &H to denote hexadecimal numbers.

If you have another version of BASIC or a different programming language, consult the manual for the language to find the correct formats for these commands. Also see Appendix C.



# SelecType

The LX-800's SelecType feature can produce four special typesyles:

**This is emphasized printing.**

**This is in the double-strike mode.**

**This is condensed printing.**

**This is in the elite mode.**

## SelecType Operation

Using SelecType is easy. You turn on SelecType and select a typesyle, then turn off SelecType and print.

### Turning SelecType on

1. Make sure that the printer is on line.
2. Hold down the ON/OFF LINE button and press the FORM FEED button. (See Figure 3-1.) When you turn on SelecType, a short beep sounds and the ON LINE light blinks to indicate that the printer is in SelecType mode.

Figure 3-1.  
Turning SelecType on

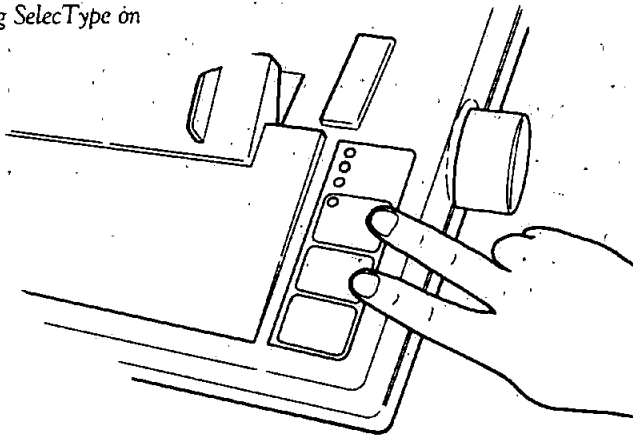

## Selecting typestyles

In SelecType, each button has a function:

- ON/OFF LINE selects typestyles.
- FORM FEED sets the styles.
- LINE FEED turns SelecType off.

After turning on SelecType, follow these steps to select a typestyle:

1. Find the typestyle you want in Table 3-1. All of the typestyles listed in the table are available for draft mode. If you are in NLQ mode, only emphasized and elite are available.

Table 3-1. SelecType modes

Mode	Typestyle or Function	
1	Emphasized	<b>ABCDEFGHIJKLMnopqrstuvwxyz</b>
2	Double-strike	<b>ABCDEFGHIJKLMnopqrstuvwxyz</b>
3	Condensed	<b>ABCDEFGHIJKLMnopqrstuvwxyz</b>
4	Elite	<b>ABCDEFGHIJKLMnopqrstuvwxyz</b>

2. Press the ON/OFF LINE button the number of times indicated in the mode column. Be sure that the printer beeps each time you press the ON/OFF LINE button.
3. Press the FORM FEED button to set the typestyle.
4. Press the LINE FEED button to turn SelecType off. The control panel returns to its normal functions, but the printer is off line.
5. Press the ON/OFF LINE button, and you are ready to print.

You can combine any of the modes listed in Table 3-1 when you are in draft mode, except for emphasized and condensed. In NLQ, the two available modes (emphasized and elite) may be combined.

If you wish to combine two modes, follow steps 1 through 3 above, then return to step 1 and follow the entire sequence (steps 1 through 5). (Do the same thing to combine three modes, but repeat steps 1 through 3 for each of the first two modes you enter.) Always select the lowest mode number first.

When you press the ON/OFF LINE button to select an additional mode, start counting again where you left off. That is, if you have selected emphasized and wish to combine that with elite, press the ON/OFF LINE button three more times, not four, to select elite. For example, follow these steps to combine emphasized and elite:

1. Press the ON/OFF LINE button once to select emphasized.
2. Press the FORM FEED button.
3. Press the ON/OFF LINE button three more times to select elite. (The mode is four, but remember that you have already pressed the ON/OFF LINE button once.)
4. Press the FORM FEED button.
5. Press the LINE FEED button.
6. Press the ON/OFF LINE button, and you are ready to print.

---

### Note

Some application programs are designed to control all typestyle functions. These programs cancel previous typestyle settings by sending certain printer codes before printing. Because these codes cancel SelecType settings, you will have to use the program's print options function instead of SelecType to select your typestyles. Therefore, if SelecType does not work with a particular application program, consult its manual on how to select typestyles.

---

---

### SelecType Tips

Once you have learned the simple technique for controlling print styles with SelecType, you can use it whenever you wish. You should be aware of a few points, however.

- SelecType is designed to control the printing of an entire file or document, not an individual line or word.
- If you are using the NLQ mode, remember that the following SelecType modes are not available: double-strike and condensed.

- If there are print codes in the document or file you are printing, those codes will override your SelecType settings. This seldom happens, since you usually won't use SelecType with files that have such codes, but if your LX-800 follows the SelecType instructions for only part of a document, print codes in the document may conflict with the SelecType modes.
- After you turn on a mode with SelecType, it stays in effect until the printer is turned off or until you send a software command that overrides it. (In general, software commands override SelecType settings.) If, for example, you use SelecType to print a document in emphasized type, anything you print after that will be emphasized unless you first turn the printer off and back on.

### LX-800 Printer Features

You can obtain many different printing effects with the LX-800 printer, from arranging the printout on the paper to giving extra emphasis to particular words and phrases. This chapter shows you the features you may want to select with your software. Once you have read about the features, you can find their commands in the Command Summary.

SelecType, as you know, controls the printing style of a whole document. Software commands, on the other hand, can change anything from a single character to the entire document.

---

#### Quality and Fonts

The most fundamental changes you can make to printing on the LX-800 are in the print quality and NLQ fonts.

The LX-800 has two levels of print quality: draft and NLQ (Near Letter Quality). Draft printing is fast, making it ideal for drafts and other preliminary work. NLQ printing takes a little longer, but it produces more fully-formed characters for presentation-quality documents.

The printout below shows the differences between draft, NLQ Roman, and NLQ Sans Serif so that you can compare the different styles and densities:

Draft printing is extremely fast.  
NLQ Roman is clear and typewriter-like.  
NLQ Sans Serif is crisp and distinctive.

The buttons on the control panel give you an easy way of changing the print quality and NLQ font, but if you prefer to print in NLQ Roman most of the time, you can select it with a DIP switch (see Appendix D). You can also choose the print quality and NLQ font with software commands.

---

## Print Size and Character Width

To add greater variety to your documents, the LX-800 has two pitches and condensed printing. All can be selected either with SelecType or a software command, and software commands also offer another option: double-wide.

### Pitches

The two pitches are pica and elite. Pica is 10 characters per inch (cpi) and elite is 12 cpi. The printout below shows the difference between the two.

Pica: ABCDEFGHIJKLMNOPQRSTUVWXYZ  
Elite: ABCDEFGHIJKLMNOPQRSTUVWXYZ

### Double-wide and condensed

In addition to the basic pitches, the LX-800 offers two other modes that change the size of your printing. These modes are double-wide and condensed.

The double-wide mode doubles the width of any size of characters. This mode is useful for such purposes as emphasizing headings in reports and making displays, but is usually not suitable for large amounts of text.

**Double-wide pica**  
**Double-wide elite**

Pica and elite are reduced to about 60% of their normal width with the condensed mode. This mode is particularly useful for printing wide spreadsheets because condensed elite allows you up to 160 characters on an 8-inch line.

Condensed can be selected with SelecType, by setting a DIP switch (see Appendix D), or with a software command. Even if you turn condensed on with the DIP switch, you can still turn it off with SelecType or the software command.

Condensed pica gives more characters on a line.  
Condensed elite gives you even more.

Widening or narrowing the characters also widens or narrows the spaces between words and letters. Because word processors usually create a left margin by printing spaces, you may need to change the number of characters on a line to keep the margins correct if you change widths. For example, a left margin of five pica characters is the same as one of six elite characters.

---

## Special Effects and Emphasis

The LX-800 offers two ways of emphasizing parts of your text and also allows you to use underlining, superscripts, and subscripts. Most of these features can be controlled only by software commands, but many application programs can produce them if they are properly installed.

Emphasized and double-strike modes, both of which can be chosen with SelectType, slow the printer down slightly to produce bolder text. In emphasized mode, the LX-800 prints each character twice as the print head moves across the paper, with the second slightly to the right of the first. This produces darker, more fully-formed characters.

In double-strike mode, the LX-800 prints each line twice, with the second slightly below the first. This makes the characters bolder. While NLQ is in use, however, double-strike is ignored because NLQ characters are already formed by two passes of the print head.

**This is normal NLQ printing.**

**This is emphasized NLQ printing.**

Superscripts and subscripts are valuable for such purposes as printing footnote numbers or parts of mathematical formulas, and the underline mode provides an automatic way of underlining fully any piece of text. It underlines spaces, subscripts, and superscripts without a break.

The example below shows underlining with text and combined with superscripts and subscripts in a mathematical formula.

$$\text{average} = \frac{(a_1 + a_2 + \dots + a_n)}{n}$$

## Using Different Character Sets

The LX-800 incorporates a new character set: Epson Character Graphics. This set allows you to take advantage of the power of the Epson mode commands and still print out the character graphics used by IBM and compatible computers and by much commercial software. For example, if your word processor can include the characters to draw boxes and shade areas, you can produce some very professional effects.

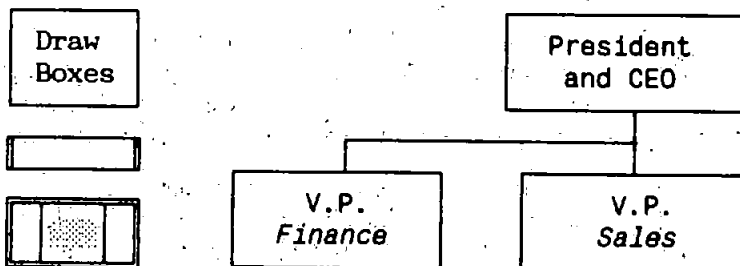

You can select the Epson Character Graphics set with your software or by setting DIP switch 1-3 ON. For many applications it is best to use the DIP switch instead of the software command because the character graphics are then available as soon as you turn the printer on.

The other important change you can make to the standard character set is to change some characters for ones commonly used in other languages—chiefly European and Scandinavian—such as accented characters and symbols. Eight international character sets can be selected by setting DIP switches 1-6 to 1-8: USA, French, German, UK, Danish, Swedish, Italian, and Spanish. See Appendix D for the DIP switch settings.

These eight, and five more, can also be selected by a software command. The additional character sets are the following: Norwegian, a second Danish set, Japanese, a second Spanish set, and Latin American. A complete list of these characters is in Appendix B.

Also, all text characters can be printed in italics. You can use this typestyle for special emphasis or as an alternative typeface.

*Italics give emphasis to words.  
They are an attractive alternative style.*

---

## Page Layout and Other Commands

The remaining commands in the Command Summary are not normally needed when using commercial software. You may need some of them if you are using a printer installation program provided with an application package, but most deal with features (such as tabs, margins, and line spacing) that are provided directly by commercial programs and are therefore only useful to you if you want to program the printer using a programming language such as BASIC.



### User-defined Characters

The LX-800 has several hundred different characters stored in its ROM (Read Only Memory). Although this number includes draft, italic, international, Character Graphics, and NLQ (Near Letter Quality) characters, sometimes you may want to have a few more. For those occasions when you need a special character or a few letters in a different typeface, the LX-800 allows you to create your own characters and print them just as if they were ordinary letters.

---

#### Defining Your Own Characters

The printout below displays a few such characters to give you an idea of what can be done, but remember that these characters are truly user-defined; you create what you need or want.



The procedure for designing a character is a simple three-step process:

- Plan your character
- Run one program to test your work and calculate the required DATA numbers
- Run another program to put the character in your printer's RAM (Random Access Memory) for use whenever you need it.

Because the high-resolution NLQ mode uses many more dots per character than the draft mode, defining NLQ characters is somewhat more complex than defining draft characters. You can find the programs for defining NLQ characters at the end of this chapter.

After you have created your own characters with these programs, certain keys that you seldom use generate the user-defined characters. For example, you can type < to print .

You can create any type of character. The only restriction is that the characters you define must follow the same rules that govern the rest of the characters printed by the LX-800. They must fit into an 11 x 9 matrix, no dot can overlap another, and either the top or the bottom row must be empty.

---

## Designing Process

Suppose you want to print the scientific symbol for the planet Mercury. Although the LX-800 has a number of special symbols, that is not one of them. First, use a grid like the one in Figure 5-1 to plan where to place the dots.

---

Figure 5-1.  
*Grid for designing draft characters*

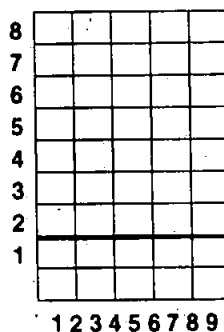

Because the last two columns are reserved for the space between characters, they are not included in the grid. And since most characters do not use the bottom two rows, there is a heavy line to indicate the usual lower limit for an LX-800 character.

When you place your dots on this grid, remember that dots cannot go on horizontal lines, but they can go on vertical lines so long as they do not overlap any other dots. As you design your characters, draw

the dots as large as you see them in the example on the left in Figure 5-2. If you draw them smaller, you may have overlapping dots without realizing it.

Figure 5-2.  
Correct and incorrect designs

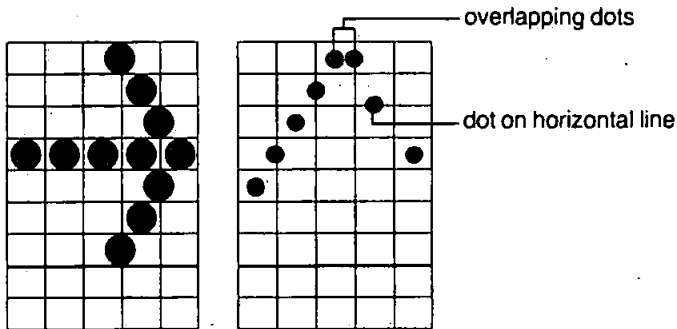

If you do accidentally overlap dots, don't worry. The program will still work, but only one of the dots will be printed.

### First definition program

Once you have drawn your dots on the grid, type in the following BASIC program and run it. If you are using Applesoft™ BASIC, see Appendix C:

```

100 DIM F(9)
110 FOR I=1 TO 9
120 PRINT "WHICH ROWS HAVE DOTS IN COLUMN";I
130 INPUT R: IF R=0 THEN 150
140 F(I)=F(I)+2^(R-1)
150 IF R=0 THEN NEXT I ELSE GOTO 130
160 LPRINT CHR$(27)":"CHR$(0)CHR$(0)CHR$(0);
170 LPRINT CHR$(27)%"CHR$(1)CHR$(0);
180 LPRINT CHR$(27)%"CHR$(0)CHR$(60)CHR$(60);
190 LPRINT CHR$(128);

```



To see program 1 produce the character in Figure 5-3, run the program and follow these instructions:

1. When the screen message asks what rows have dots in column 1, press **Enter** to indicate that no dots go in that column.
2. For column 2 (the vertical line) press 7, **Enter**, 5, and **Enter** again to indicate that you want dots in rows 7 and 5. Then press **Enter** alone to indicate that no more dots go in column 2.
3. For column 3 press 8, 6, 4, and 2, and **Enter** after each of them. Press **Enter** to finish with column 3 and go on to column 4.
4. For column 4 press **Enter** only. (The rest of the directions assume that you know to press **Enter** after each number and one extra time to end the entries for each column.)
5. For column 5 enter 6, 4, 3, 2, and 1.
6. For column 6 press **Enter** only.
7. For column 7 enter 8, 6, 4, and 2.
8. For column 8 enter 7 and 5.
9. For column 9 press **Enter** only.

Now wait a moment for your computer to calculate the dot patterns and your LX-800 to print the new character in two different typesyles. Your printout also gives you nine numbers, which you use in the next program. You should get the printout you see below:

```
YOUR CHARACTER IN PICA:  # # #
IN DOUBLE-WIDTH EMPHASIZED PICA:  ## ## ##
YOUR DATA NUMBERS:
0 80 170 0 47 0 170 80 0
```

When you get to this point with a character of your own, you see how it looks. If you want to make any changes, move the dots as needed and re-run the program.

If you want to put dots in the bottom row, change the number in line 190 from 128 to 0. Then the usable rows are those shown in Figure 5-4 below.

Figure 5-4.  
Using the bottom eight rows

8									
7									
6									
5									
4									
3									
2									
1									
	1	2	3	4	5	6	7	8	9

### Second definition program

Once the character looks the way you want it to, you can enter, modify, and run the next program. The program as listed creates the Mercury character, but you can use it for any characters you create if you make one or two changes, as explained after the program listing.

```

90 FOR P=58 TO 63: LPRINT CHR$(P);" ";: NEXT P
95 LPRINT
100 K=1: IF K>3 THEN A=58. ELSE A=60
110 LPRINT CHR$(27):""CHR$(0)CHR$(0)CHR$(0);
120 LPRINT CHR$(27)"%"CHR$(1)CHR$(0);
130 LPRINT CHR$(27)"&"CHR$(0)CHR$(A)CHR$(A-1+K);
140 FOR Z=1 TO K
150 LPRINT CHR$(128);
160 FOR X=1 TO 9
170 READ R
180 LPRINT CHR$(R);: NEXT X
190 LPRINT CHR$(0)CHR$(0);
200 NEXT Z
210 DATA 0,80,170,0,47,0,170,80,0
290 FOR P=58 TO 63: LPRINT CHR$(P);" ";: NEXT P

```

To use this program for your own character or characters, change the DATA numbers in line 210 by substituting the numbers generated by the first program when you created your own character. If you have

created more than one character, put the DATA numbers for each character on a separate line as you see in the example below:

```
210 DATA 112,8,0,138,116,138,0,8,112
220 DATA 56,68,146,40,130,40,130,68,56
```

Check your work by making sure there are nine numbers in each line and the numbers are separated by commas. Also make the change in line 100 explained below.

Line 100 states  $K=1$ ; to define more than one character, use the total number of characters you are defining instead of the 1 in that line. (You can define as many as six characters. Just run the first program several times and enter all the DATA numbers in this program.)

### Running the program

When you run this second program, it prints six characters, then re-defines some or all of them and prints them again, as in the example below.

```
: ; < = > ?
: ; Ψ ⊕ ♯ ?
```

When printed by your own program, these two lines provide you with a key to the characters your LX-800 can now print. When you press the key for one of the characters in the top row, the printer prints the corresponding character in the bottom row. In the example above, if you type < your LX-800 prints ♯ (although your screen continues to show the character <).

Because the program puts these new definitions in your printer's Random Access Memory (RAM), it prints the new characters (the ones in the bottom row) unless it is turned off.

If you have designed a few characters and want to use them with your word processing program, for example, just run the second definition program before you start using your word processing program. Then use the two-line printout as your guide to tell you which keys to press for your new characters.

---

## Defining NLQ Characters

Since NLQ characters use many more dots than draft characters, defining NLQ characters is more complex than designing draft ones. If

you use the grid and the programs in this section, however, you can design your own NLQ characters.

### NLQ grid

Because the NLQ characters can use as many as 18 dots vertically and 12 dots horizontally, you plan your designs on a different grid than the one you used for draft characters. See Figure 5-5.

Figure 5-5.  
Grid for NLQ characters

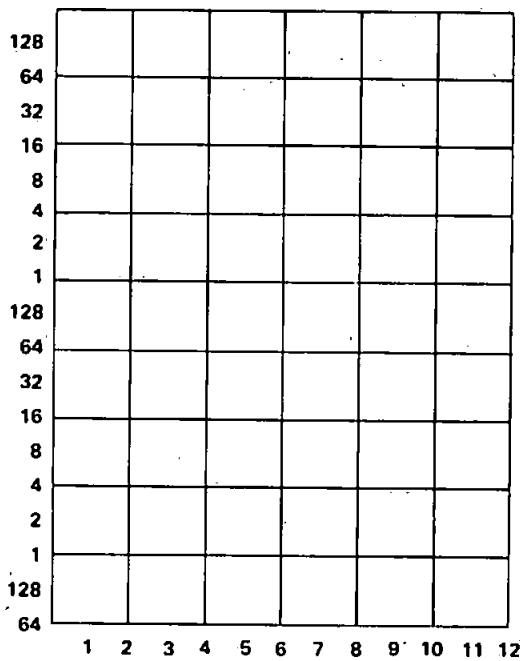

On this grid you can use any numbered line or space. As you can see, that includes the bottom line and the line on the right side. You should remember to leave one or two columns blank for space between characters, however.

Each NLQ character definition requires 36 data numbers. Therefore, each vertical column must be divided into three sections for the calculation of data numbers. The process is not difficult once you get some practice using it.

Figure 5-6 shows a single column to make clear how the data numbers are calculated. Notice that in designing NLQ characters circles are used instead of dots to make it easier to keep track of overlapping dots.

Figure 5-6.  
Data numbers for one column

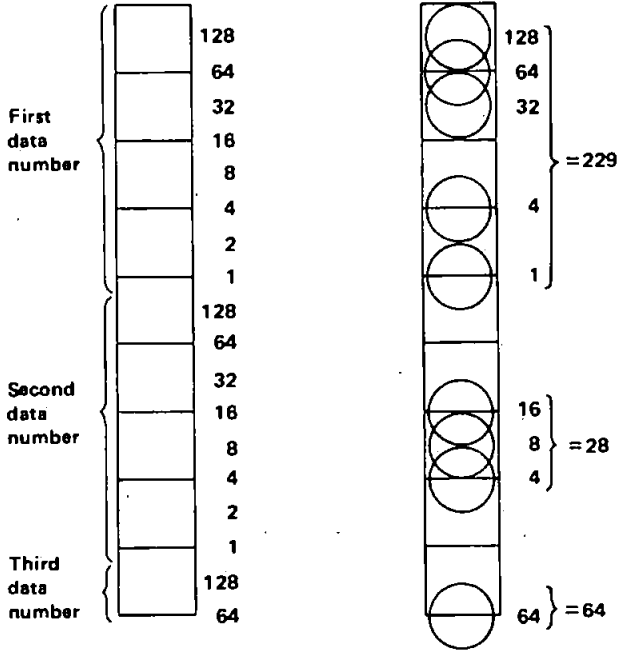

To calculate the data numbers for this column, you see which dots are used in the top group (the top eight positions) and add their values together. Then you go down to the middle group (the next eight

positions) and add the values of any dots that are used there. Finally, you look at the bottom group (two dot positions) and add together the values used there.

If no dots are used in a group, the data number for that group is zero. All zeros must be entered in the DATA statements for the NLQ definition programs.

Now you can learn how to use the NLQ character definition with a simple arrow design. Figure 5-7 shows the design drawn on a grid and the data numbers printed at the top or bottom of each column.

Figure 5-7.  
Arrow design and data numbers

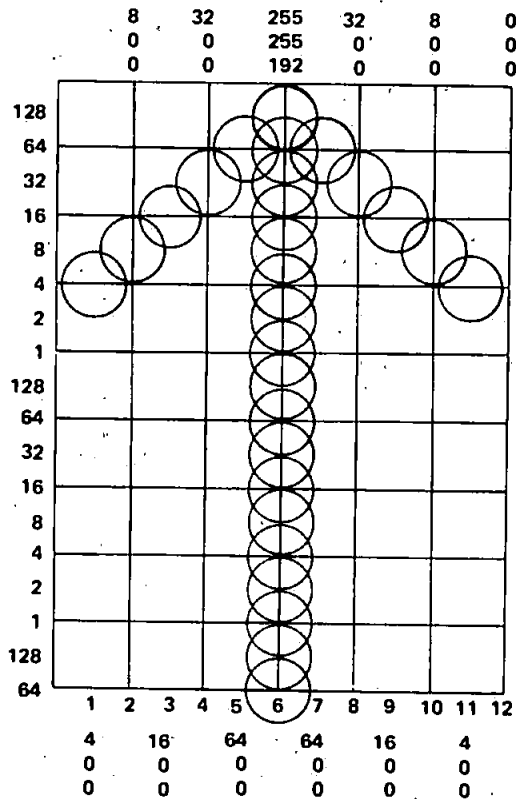

If you look at each column individually, you can see how the data numbers were calculated.

### First NLQ definition program

Now type in and run the following program. It has the data numbers for the arrow design. For a character of your own, change the data numbers in lines 130-150.

```
10 LPRINT CHR$(27);"x1";
20 LPRINT CHR$(27);".";CHR$(0);CHR$(0);CHR$(0);
30 LPRINT CHR$(27);"#";CHR$(1);CHR$(0);
40 LPRINT CHR$(27);"&";CHR$(0);"< <";
50 LPRINT CHR$(0);CHR$(12);CHR$(0);
60 FOR X=1 TO 36
70 READ C: LPRINT CHR$(C);
80 NEXT X
90 LPRINT "YOUR CHARACTER IN PICA: < < <"
100 LPRINT "IN DOUBLE-WIDE EMPHASIZED PICA: ";
110 LPRINT CHR$(27);"!*< < <"
120 LPRINT CHR$(27);"!";CHR$(0);
130 DATA 4,0,0,8,0,0,16,0,0,32,0,0
140 DATA 64,0,0,255,255,192,64,0,0,32,0,0
150 DATA 16,0,0,8,0,0,4,0,0,0,0,0
```

```
YOUR CHARACTER IN PICA: ↑ ↑ ↑
IN DOUBLE-WIDE EMPHASIZED PICA: ↑ ↑ ↑
```

When you run this program for your own character, you can see if it looks right. If not, move the dots as needed, recalculate and change the data numbers, and run the program again.

### Second NLQ definition program

When you are satisfied with the character you have created, enter and run the next program. Use your data numbers instead of the ones in lines 140-160. If you want to define more than one character, change line 10 so that J equals the total number of characters you are defining (the maximum is six) and enter the extra data numbers (36 for each character).

```

10 J=1: IF J>3 THEN A=58 ELSE A=60
20 LPRINT CHR$(27)"x"CHR$(1)
30 FOR X=58 TO 63: LPRINT CHR$(X) " ";: NEXT X
40 LPRINT
50 LPRINT CHR$(27):""CHR$(0)CHR$(0)CHR$(0)
60 LPRINT CHR$(27)"%"CHR$(1)CHR$(0);
70 LPRINT CHR$(27)"&"CHR$(0)CHR$(A)CHR$(A-1+J);
80 FOR Y=1 TO J
90 LPRINT CHR$(0)CHR$(12)CHR$(0);
100 FOR X=1 TO 36
110 READ C: LPRINT CHR$(C);
120 NEXT X: NEXT Y
130 FOR X=58 TO 63: LPRINT CHR$(X) " ";: NEXT X
140 DATA 4,0,0,8,0,0,16,0,0,32,0,0
150 DATA 64,0,0,255,255,192,64,0,0,32,0,0
160 DATA 16,0,0,8,0,0,4,0,0,0,0,0

```

When you run this program, it prints six characters, then redefines one or more of them and prints them again. As with the draft characters, you use this two-line printout as a guide to the new characters your LX-800 can print. You can use them with an application program or a program you write yourself.

## Chapter 6

### Introduction to Dot Graphics

---

The dot graphics mode allows your LX-800 to produce pictures, graphs, charts, or almost any other pictorial material you can devise. Because many commercial software programs use graphics, you may be able to print pictures and graphs like the ones on this page and the next by simply giving your software a few instructions.

The quickest and easiest way to print graphics on your LX-800 is to use a commercial graphics program. With such programs you usually create an image on your monitor and then give a command to send the image to the printer.



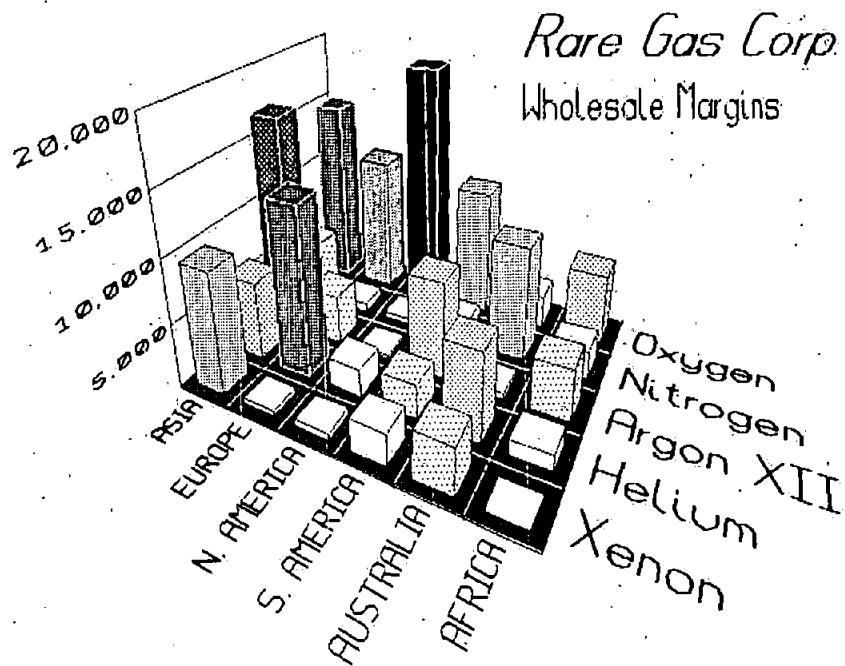

If you use commercial software that produces graphics, all you need to know about dot graphics is how to use the software. If, on the other hand, you wish to do your own programming or merely wish to understand how the LX-800 prints graphics, read on.

## The Print Head

To understand dot graphics you need to know a little about how the LX-800's print head works.

The LX-800's print head has nine pins. As it moves across the page, electrical impulses cause the pins to fire. Each time a pin fires, it strikes the inked ribbon and presses it against the paper to produce a small dot. As the head moves across the paper, the pins fire time after time in different patterns to produce letters, numbers, or symbols.

## Dot patterns

The LX-800's print head is able to print graphics in addition to text because graphic images are formed on the LX-800 about the same way that pictures in newspapers and magazines are printed.

If you look closely at a newspaper photograph, you can see that it is made up of many small dots. The LX-800 also forms its images with patterns of dots, as many as 240 dot positions per inch horizontally and 72 dots vertically. The images printed by the LX-800 can, therefore, be as finely detailed as the one on the first page of this chapter.

In its main graphics mode the LX-800 prints one column of dots for each code it receives, and it uses only the top eight of the nine pins. Therefore, your graphics program must send codes for dot patterns, one number for each column in a line. For each of those columns the print head prints the pattern of dots you have specified.

To print figures taller than eight dots, the print head makes more than one pass. The printer prints one line, then advances the paper and prints another, just as it does with text.

To keep the print head from leaving gaps between the graphics lines as it does between the text lines, the line spacing must be changed to eliminate the space between lines. With a change in line spacing, the LX-800 can print finely detailed graphic images that give no indication that they are made up of separate lines, each no more than  $8/72$ nds of an inch tall.

Each pass of the print head prints one piece of the total pattern, which can be as tall or short and as wide or narrow as you desire. You don't have to fill the whole page or even an entire line with your graphics figures. In fact, you can use as little or as much space as you like for a figure and put it anywhere on the page.

---

## Pin Labels

The graphics mode requires a method to tell the printer which pins to fire in each column. Since there are 256 possible combinations of eight pins, you need a numbering system that allows you to use a single number to specify which of the 256 possible patterns you want. This numbering system is shown in Figure 6-1 on the next page.

To fire any one pin, you send its number. To fire more than one pin at the same time, add up the numbers of the pins and send the sum to the printer. Therefore, with these labels for the pins, you fire the top pin by sending 128. To fire the bottom pin, you send 1. If you want to fire only the top and bottom pins, you simply add 128 and 1, then send 129.

By adding the appropriate label numbers together, you can fire any combination of pins. Figure 6-1 shows three examples of how to calculate the number that fires a particular pattern of pins.

Figure 6-1.  
Pin numbering system

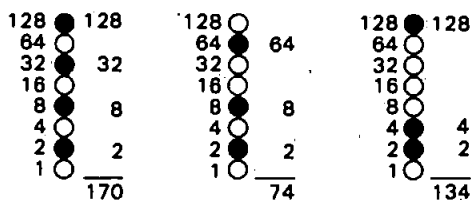

With this numbering system, any combination of the eight pins adds up to a decimal number between 0 and 255, and no numbers are duplicated. Before you can put these numbers in a graphics program, however, you need to know the format of the graphics commands.

## Graphics Commands

The graphics mode commands are quite different from most other commands. For most of the other modes, such as emphasized and double-wide, one command turns the mode on and another turns it off. For graphics, the command is more complicated because the command that turns on a graphics mode also specifies how many columns of graphics will be printed. After the printer receives this command, it interprets the next numbers as pin patterns and prints them on the paper.

## The graphics command format

There are several different graphics commands giving different horizontal dot densities and printing speeds. Because the format is almost the same for all the commands, however, the example here keeps things simple by using only the single-density graphics command, ESC K. In single-density graphics, there are 60 dots per inch horizontally.

The command to enter single-density graphics mode is ESC K  $n1$   $n2$ . In BASIC the command is given in this format:

```
LPRINT CHR$(27);"K";CHR$(n1);CHR$(n2);
```

ESC K specifies single-density graphics, and the next two numbers ( $n1$  and  $n2$ ) specify the number of columns reserved for graphics.

### Column reservation numbers

Even in single-density graphics mode, one 8-inch line can accommodate 480 columns of graphics; in quadruple-density, almost 2000 columns can fit on the same 8-inch line. Since the printer does not use decimal numbers larger than 255, the graphics commands use two numbers for reserving columns.

Because the commands are set up for two numbers, you must supply two even if you need only one. When you need fewer than 256 columns, it is easy to determine  $n1$  and  $n2$ :  $n1$  is the number of columns you are reserving and  $n2$  is zero. For example, to send data for 200 columns of graphics,  $n1$  is 200 and  $n2$  is 0.

For more than 256 columns of graphics data,  $n2$  is the number of complete groups of 256 columns, and  $n1$  is the number of columns to complete the line. For example, to send 1632 columns of graphic data,  $n1$  is 96 and  $n2$  is 6 because  $96 + (6 \times 256) = 1632$ .

You can calculate both  $n1$  and  $n2$  by dividing the total number of columns by 256. The quotient is  $n2$  and the remainder is  $n1$ . If you are using a programming language with MOD (modulus) and INT (integer) functions, you can use the following formulas, in which  $n$  is the total number of columns.

$$\begin{aligned}n1 &= n \text{ MOD } 256 \\n2 &= \text{INT}(n/256)\end{aligned}$$

## Graphics data

After receiving a graphics command such as ESC K n1 n2, the printer prints the number of codes specified by n1 and n2 as graphics data, no matter what codes they are. This means that you must be sure to supply exactly the right amount of graphics data. If you supply too little, the printer will stop and wait for more data and will seem to be locked. The next data sent will then be printed as graphics, even if it is really text. On the other hand, if you supply too much graphics data, the excess will be printed as regular text.

---

## Simple Graphics Programming

The first example in this section shows how a graphics command, column reservation numbers, and data can be used to print a single line of graphics. The example is a BASIC program. If you prefer another programming language, the principles are exactly the same. Therefore, you can easily adapt the program to the language you prefer.

The first line of the program specifies single-density graphics for 40 columns:

```
100 LPRINT CHR$(27);"K";CHR$(40);CHR$(0);
```

The second line is the data that is printed as pin patterns. It uses the number 74 to produce one of the patterns shown in Figure 6-1. The FOR-NEXT loop sends 40 columns of data.

```
200 FOR X=1 TO 40: LPRINT CHR$(74);: NEXT X
```

That is the whole program. In BASIC, semicolons at the ends of the lines are very important; they prevent the computer from sending other codes after the ones you specify. In other languages you may have to use a special command to send a single code at a time. Run the program to see the result below. Although it is not as interesting as the examples at the beginning of this chapter, it shows exactly how the mode works.

```
=====
```

## WIDTH statements

Some software (including most versions of BASIC) automatically inserts carriage return and line feed codes after every 80 or 130 characters. This is usually no problem with text, but it can spoil your graphics. Two extra columns of graphics are printed in the middle of the ones you send, and are left over and printed as text.

In some versions of BASIC you can prevent unwanted control codes in graphics by putting a WIDTH statement at the beginning of all graphics programs. The format in many forms of BASIC is either WIDTH "LPT1:", 255 or WIDTH LPRINT 255. Check your software manual for the proper format.

## Printing taller patterns

The next example shows how several lines of graphics can be formed into a figure taller than eight dots. It uses programming techniques for producing textured or repetitive patterns.

The program is listed below. The lines inside each pair of FOR and NEXT statements have been indented so that you can see how the program works; the spaces are not needed for the program to run.

```
100 WIDTH "LPT1:", 255
110 LPRINT CHR$(27);"A";CHR$(8);
120 FOR R = 1 TO 6
130   LPRINT CHR$(27);"K";CHR$(100);CHR$(0);
140   FOR X = 1 TO 50
150     LPRINT CHR$(170);CHR$(85);
160   NEXT X: LPRINT
170 NEXT R
180 LPRINT CHR$(27);"@"
```

If you run the program, you will see how it combines six print lines into a pattern.

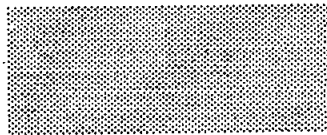

There are five basic steps that the program goes through to produce this kind of pattern.

1. The computer is prevented from adding any extra characters by the WIDTH statement (line 100).
2. The line spacing is changed to 8/72 of an inch—the height of the dot patterns used in the program (line 110).
3. The program goes through the graphics commands the required number of times (lines 120 and 170).
4. A new graphics command is used for each line printed (lines 130-160). This part of the program is similar to the last example, but two columns are printed each time through the loop making a total of 100.
5. The last important thing to do is to reset the printer to its default settings, including the normal line spacing (line 180).

Notice that the graphics command (ESC K) can be in effect for only one print line. To print more than one line of graphics, the graphics command must be issued before each line.

---

## Density Varieties

Although all the examples so far in this chapter have been in the single-density graphics mode, there are six other eight-pin densities and two that use all nine pins. Nine-pin graphics is not necessary for most uses, but you can find the command (ESC ^) in the Command Summary (Appendix A).

The four most common eight-pin modes are ESC K, ESC L, ESC Y, and ESC Z. There is also a general-purpose command for any of the eight-pin graphics modes: ESC \*. This command is used in the same way as the individual commands, except that before *n1* and *n2* you must send the code for the graphics mode required. The different modes are summarized in Table 6-1.

The following example shows how to use the ESC \* command to reserve 40 columns for single-density graphics. This uses mode number 0 from the table to achieve exactly the same effect as the first example using ESC K.

```
LPRINT CHR$(27);"*";CHR$(0);CHR$(40);CHR$(0);
```

Table 6-1. Graphics modes

Option	Alternate Code	<i>m</i>	Horiz. density (dots/in.)
Single-density	ESC K	0	60
Double-density	ESC L	1	120
High-speed double-density*	ESC Y	2	120
Quadruple-density*	ESC Z	3	240
CRT I	none	4	80
Plotter (1:1)	none	5	72
CRT II	none	6	90

\*Adjacent dots cannot be printed in this mode.

Modes 4-6 in the table are special modes that alter the horizontal density to give proportions of a computer monitor (the CRT modes), or to match the vertical density so as to give round circles (the plotter mode).

In two modes, high-speed double-density and quadruple-density, the print head cannot print two consecutive dots with the same pin, so that it can print dots in only half the possible dot positions in any one row. The higher density means that the resolution of the pattern is better than in single-density mode. When you design patterns in these two modes, however, you must see that no dots overlap.

### Reassigning a graphics mode

Another graphics command lets you assign a different eight-pin graphics mode to one of the specific eight-pin graphics commands. You can use it with graphics software programs to quickly change the density and proportions of your printouts. Changing the graphics option changes the width without changing the height.

The command for reassigning a graphics mode is ESC ? *c m*. In this command, *c* is a letter designating one of the four alternate graphics codes (K, L, Y, or Z) and *m* is the mode number of the new mode, as listed in Table 6-1.

For example, to change the ESC K command to select the CRT I screen graphics mode, the command in BASIC would be the following:

```
LPRINT CHR$(27);"?K";CHR$(4);
```

A little experimentation should tell you whether the reassigning code can improve your graphics printouts.

---

## Designing Your Own Graphics

This section takes you through the development of a graphics program. The example is not especially complicated, but it does include the same steps you would use for a more complex figure.

You should plan your figure with dots on graph paper, but before beginning to place the dots, you must decide which graphics density you want. Figure 6-2 shows the differences between three common modes so that you can choose the one you want.

In this figure you can see the main rules for graphic design in the three densities:

- In single-density no dots can be placed on vertical lines.
- In high-speed double-density, dots can be placed on vertical lines, but no dots can overlap.
- In double-density, dots can be placed on vertical lines, and they can overlap.

Figure 6-2.  
*Designing in different densities*

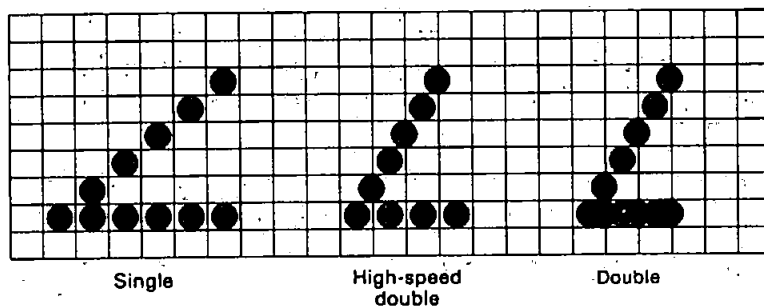



The numbers for the second line were calculated in the same way. Once the numbers for the pin patterns are calculated, they are put in the program in DATA statements, separated by commas.

The program works in a similar way to the last example. This time it selects 7/72-inch line spacing because only seven pins are used. Because the data is not repetitive, each column of graphics data is read from the DATA statements and sent to the printer. The design is 41 dot positions wide. Therefore both lines 130 and 140 use the number 41.

```
100 WIDTH "LPT1:", 255
110 LPRINT CHR$(27);"A";CHR$(7);
120 FOR ROW = 1 TO 2
130 LPRINT CHR$(27);"Y";CHR$(41);CHR$(0);
140   FOR COLUMN = 1 TO 41
150     READ N
160     LPRINT CHR$(N);
170   NEXT COLUMN
180 LPRINT
190 NEXT ROW
200 END
210 DATA 64,32,80,8,68,2,64,0,64,0
220 DATA 64,0,64,0,32,0,16,0,8,0
230 DATA 8,0,8,0,8,0,8,0,8,0,8,0
240 DATA 184,64,32,16,8,4,2
250 DATA 8,16,40,64,136,0,8,0,8,0
260 DATA 8,0,8,0,16,0,32,0,64,0,64,0
270 DATA 64,0,64,0,64,0,64,0,64,0,64,0
280 DATA 116,8,16,32,64,128,0
```

When you run this program, it produces the following printout:



If you want to see the figure in other densities, change the Y in line 130 to L or Z.

## Appendix A

---

### Command Summary

This appendix lists and describes all the commands available on the LX-800.

The first part of this appendix lists all commands in numerical order and gives the page number where each is fully described. If you know which command you are looking for, consult the numerical list to find the page number where it is described.

The Quick Reference card at the end of the book also contains a list of the commands divided by topic, with page number references that direct you to full explanations of the commands.

The second part of this appendix lists and describes the commands. They are divided into the following subjects:

Printer Operation	Print Enhancement
Data Control	Word Processing
Vertical/Horizontal Motion	Character Sets
Overall Printing Style	User-defined Characters
Print Size and Character Width	Graphics

In this appendix each command has a format section and a comment section. The format section gives the ASCII, decimal, and hexadecimal values for the command; the comment section describes the effect of the command and gives any additional information necessary for using it.

All three formats are equivalent, and it should be easy to pick the one most suited to your purpose.

---

#### Note

Some application programs can use control key sequences. See the Control Key chart on page A-3 for information on using these.

---

For the following commands that use only 0 or 1 for the variable, either the ASCII codes 1 and 0 or the characters 1 and 0 can be used:

ESC s, ESC U, ESC x, ESC W, ESC S, ESC -, and  
ESC %

For example, in BASIC you can turn on double-wide with either of these statements:

```
LPRINT CHR$(27);"W";CHR$(1)
LPRINT CHR$(27);"W";"1"
```

The simplest type of command consists of a single character to be sent to the printer. For instance, to print in condensed mode the code format is:

ASCII code:	SI
Decimal:	15
Hexadecimal:	0F

More complex commands consist of two or more character codes. For example, to print in elite mode the code format is the following:

ASCII code:	ESC	M	n
Decimal:	27	77	n
Hexadecimal:	1B	4D	n

In this case n can be either 1 or 0, to begin or end elite printing. You can use either of the following commands to turn ON elite print from BASIC:

```
LPRINT CHR$(27);CHR$(77);CHR$(1)
LPRINT CHR$(27);"M";CHR$(1)
```

## Control key chart

Some application programs can use control key codes for decimal values 0-27. The table below gives you the proper values. The Control Key column indicates that you press the control key at the same time you press the key for the letter or symbol in that column. For example, you press the control key and A at the same time to send the value 1.

Some programs that use this system cannot use control-@, and many programs use the control keys for other purposes.

Dec.	Hex.	Control Key
0	00	@
1	01	A
2	02	B
3	03	C
4	04	D
5	05	E
6	06	F
7	07	G
8	08	H
9	09	I
10	0A	J
11	0B	K
12	0C	L
13	0D	M
14	0E	N
15	0F	O
16	10	P
17	11	Q
18	12	R
19	13	S
20	14	T
21	15	U
22	16	V
23	17	W
24	18	X
25	19	Y
26	1A	Z
27	1B	[

## Commands in Numerical Order

This section lists all the LX-800 commands, with their decimal and hexadecimal values. The numbers in the columns on the right are the page numbers in this appendix where a complete description of the command can be found.

ASCII	Dec	Hex	Description	Page
BEL	7	07	Beeper	A-10
BS	8	08	Backspace	A-17
HT	9	09	Tab horizontally	A-18
LF	10	0A	Line feed	A-13
VT	11	0B	Tab vertically	A-15
FF	12	0C	Form feed	A-11
CR	13	0D	Carriage return	A-10
SO	14	0E	Select double-wide (1 line)	A-22
SI	15	0F	Select condensed mode	A-21
DC1	17	11	Select printer	A-7
DC2	18	12	Cancel condensed mode	A-21
DC3	19	13	Deselect printer	A-7
DC4	20	14	Cancel double-wide (1 line)	A-22
CAN	24	18	Cancel line	A-10
DEL	127	7F	Delete character	A-11
ESC SO	14	0E	Select double-wide (1 line)	A-22
ESC SI	15	0F	Select condensed mode	A-21
ESC EM	25	19	Cut sheet feeder on/off	A-9
ESC !	33	21	Master select	A-20
ESC %	37	25	Select user-defined set	A-29
ESC &	38	26	Define user-defined characters	A-29
ESC *	42	2A	Select graphics mode	A-31
ESC -	45	2D	Turn underlining on/off	A-25
ESC /	47	2F	Select vertical tab channel	A-16
ESC 0	48	30	Select 1/8-inch line spacing	A-13
ESC 1	49	31	Select 7/72-inch line spacing	A-13
ESC 2	50	32	Select 1/6-inch line spacing	A-14
ESC 3	51	33	Select n/216-inch line spacing	A-14

ASCII	Dec	Hex	Description	Page
ESC 4	52	34	Select italic mode	A-27
ESC 5	53	35	Cancel italic mode	A-27
ESC 6	54	36	Printable code area expansion	A-28
ESC 7	55	37	Cancel ESC 6	A-28
ESC 8	56	38	Disable paper-out sensor	A-9
ESC 9	57	39	Enable paper-out sensor	A-9
ESC :	58	3A	Copy ROM into RAM	A-29
ESC <	60	3C	Select unidirectional mode (1-line)	A-8
ESC ?	63	3F	Reassign graphics mode	A-31
ESC @	64	40	Initialize printer	A-7
ESC A	65	41	Select n/72-inch line spacing	A-14
ESC B	66	42	Set vertical tabs	A-15
ESC C	67	43	Set page length in lines	A-11
ESC C0	67	43	Set page length in inches	A-12
ESC D	68	44	Set horizontal tabs	A-18
ESC E	69	45	Select emphasized mode	A-23
ESC F	70	46	Cancel emphasized mode	A-23
ESC G	71	47	Select double-strike mode	A-24
ESC H	72	48	Cancel double-strike mode	A-24
ESC J	74	4A	Perform n/216-inch line feed	A-15
ESC K	75	4B	Select single-density graphics	A-30
ESC L	76	4C	Select double-density graphics	A-30
ESC M	77	4D	Select elite pitch	A-21
ESC N	78	4E	Set skip-over-perforation	A-12
ESC O	79	4F	Cancel skip-over-perforation	A-12
ESC P	80	50	Select pica pitch	A-20
ESC Q	81	51	Set right margin	A-17
ESC R	82	52	International character set	A-28
ESC S0	83	53	Select superscript mode	A-24
ESC S1	83	53	Select subscript mode	A-25
ESC T	84	54	Cancel superscript/subscript	A-25
ESC U	85	55	Turn unidirectional mode on/off	A-8
ESC W	87	57	Turn double-wide on/off	A-23
ESC Y	89	59	High-speed dbl-density graphics	A-30
ESC Z	90	5A	Quadruple-density graphics	A-31
ESC ^	94	5E	Select 9-pin graphics	A-32
ESC a	97	61	NLQ justification	A-26
ESC b	98	62	Set vertical tabs in channels	A-16
ESC e	101	65	Set tab increments	A-17
ESC f	102	66	Horizontal/vertical skip	A-18
ESC k	107	6B	Select NLQ font	A-19

ASCII	Dec	Hex	Description	Page
ESC l	108	6C	Set left margin	A-16
ESC s	115	73	Turn half-speed mode on/off	A-8
ESC t	116	74	Select character table	A-26
ESC x	120	78	Select NLQ or draft	A-19

---

## Printer Operation

### Initialization

ESC @

Initialize Printer

---

**Format:**

ASCII code:	ESC	@
Decimal:	27	64
Hexadecimal:	1B	40

**Comments:**

Resets the printer mode and clears the buffer of printable data on the print line preceding the command.

### Selection

DC1

Select Printer

---

**Format:**

ASCII code:	DC1
Decimal:	17
Hexadecimal:	11

**Comments:**

Returns the printer to the selected state if it has been deselected by the printer deselect code (DC3). Does not select the printer if it has been switched off line by pressing the ON/OFF LINE button.

DC3

Deselect Printer

---

**Format:**

ASCII code:	DC3
Decimal:	19
Hexadecimal:	13

**Comments:**

Puts the printer into the deselected state until select printer code (DC1) is received. The printer cannot be reselected with the ON/OFF LINE button.

## Speed

**ESC s** Turn Half-speed Mode On/Off

### Format:

ASCII code:	ESC	s	n
Decimal:	27	115	n
Hexadecimal:	1B	73	n

### Comments:

The following values can be used for n:

- 1: Mode is turned ON. (The characters "0" and "1" can also be used.)
- 0: Mode is turned OFF.

## Printing direction

**ESC <** Select Unidirectional Mode (one line)

### Format:

ASCII code:	ESC	<
Decimal:	27	60
Hexadecimal:	1B	3C

### Comments:

Printing is normally bidirectional. This command selects unidirectional printing for one line only. (It is cancelled by a carriage return.) The print head moves to the extreme left (home) position, and printing takes place from left to right.

**ESC U** Turn Unidirectional Mode On/Off

### Format:

ASCII code:	ESC	U	n
Decimal:	27	85	n
Hexadecimal:	1B	55	n

### Comments:

The following values can be used for n:

- 1: Mode is turned ON. (The characters "0" and "1" can also be used.)
- 0: Mode is turned OFF.

Text printing is normally bidirectional. This command selects unidirectional printing for more accurate positioning.

**ESC 8****Disable Paper-out Sensor**

---

**Format:**

ASCII code:	ESC	8
Decimal:	27	56
Hexadecimal:	1B	38

**Comments:**

Turns off the paper-out sensor so that you can print to the end of a single sheet of paper.

**ESC 9****Enable Paper-out Sensor**

---

**Format:**

ASCII code:	ESC	9
Decimal:	27	57
Hexadecimal:	1B	39

**Comments:**

Cancels ESC 8. Therefore, the printer beeper sounds and printing stops when the printer reaches a point approximately 3/4 of an inch from the end of the paper.

**ESC EM****Turn Cut Sheet Feeder Mode On/Off**

---

**Format:**

ASCII code:	ESC	EM	<i>n</i>
Decimal:	27	25	<i>n</i>
Hexadecimal:	1B	19	<i>n</i>

**Comments:**

The following values can be used for *n*:

4: Mode is turned ON.

0: Mode is turned OFF.

The variables are the *characters* "0" (48 decimal or 30 hex) and "4" (52 decimal or 34 hex). Do not use 1 decimal, 01 hex, 4 decimal, or 04 hex.

The command should not be used unless the optional cut sheet feeder is installed. It is ignored if any value other than "0" or "4" is used for *n*. The command overrides the setting of DIP switch 2-2.

## Beeper

**BEL**

**Beeper**

**Format:**

ASCII code: BEL  
Decimal: 7  
Hexadecimal: 07

**Comments:**

Sounds the printer's beeper.

---

## Data Control

**CR**

**Carriage Return**

**Format:**

ASCII code: CR  
Decimal: 13  
Hexadecimal: 0D

**Comments:**

Prints the data in the buffer and returns the print position to the left margin. A line feed may be added if DIP switch 2-4 is ON or the AUTO FEED XT line on the parallel interface is held LOW.

**CAN**

**Cancel Line**

**Format:**

ASCII code: CAN  
Decimal: 24  
Hexadecimal: 18

**Comments:**

Removes all text on the print line, but does not affect control codes.

**DEL****Delete Character****Format:**

ASCII code: DEL  
Decimal: 127  
Hexadecimal: 7F

**Comments:**

Removes the last text character on the print line but does not affect control codes.

---

**Vertical/Horizontal Motion****Form feeding****FF****Form Feed****Format:**

ASCII code: FF  
Decimal: 12  
Hexadecimal: 0C

**Comments:**

Prints the data in the print buffer and advances the paper to the top of the next form according to the current page length.

**ESC C****Set Page Length in Lines****Format:**

ASCII code:	ESC	C	<i>n</i>
Decimal:	27	67	<i>n</i>
Hexadecimal:	1B	43	<i>n</i>

**Comments:**

Sets the page length to *n* lines in the current line spacing. The value of *n* must be from 1-127. The top of form position is set to the current line.

**ESC C 0****Set Page Length in Inches****Format:**

ASCII code:	ESC	C	NUL	<i>n</i>
Decimal:	27	67	0	<i>n</i>
Hexadecimal:	1B	43	00	<i>n</i>

**Comments:**

Sets the page length to *n* inches. The value of *n* must be from 1-22. The top of form position is set to the current line.

**ESC N****Set Skip-over-perforation****Format:**

ASCII code:	ESC	N	<i>n</i>
Decimal:	27	78	<i>n</i>
Hexadecimal:	1B	4E	<i>n</i>

**Comments:**

The variable *n* is the number of lines skipped between the last line printed on one page and the first line on the next page. For example, with the standard settings for line spacing (1/6-inch), and page length (66 lines), ESC N 6 causes the LX-800 to print 60 lines and then skip 6. DIP switch 2-3 performs the same function. This setting is cancelled by ESC O and also by ESC C or ESC C NUL. The value of *n* must be from 1-127.

**ESC O****Cancel Skip-over-perforation****Format:**

ASCII code:	ESC	O
Decimal:	27	79
Hexadecimal:	1B	4F

**Comments:**

Cancels the skip-over-perforation set by ESC N. Overrides the setting of DIP switch 2-3.

## Line feeding

LF

Line Feed

### Format:

ASCII code: LF

Decimal: 10

Hexadecimal: 0A

### Comments:

When this command is received, the data in the print buffer is printed and the paper advances one line in the current line spacing.

ESC 0

Select 1/8-inch Line Spacing

### Format:

ASCII code: ESC 0

Decimal: 27 48

Hexadecimal: 1B 30

### Comments:

Sets the line spacing to 1/8 of an inch for subsequent line feed commands. The 0 is the *character* zero and not ASCII code 0.

ESC 1

Select 7/72-inch Line Spacing

### Format:

ASCII code: ESC 1

Decimal: 27 49

Hexadecimal: 1B 31

### Comments:

Sets the line spacing to 7/72 of an inch for subsequent line feed commands. The 1 is the *character* one and not lower case L or ASCII code 1.

**ESC 2****Select 1/6-inch Line Spacing****Format:**

ASCII code:	ESC	2
Decimal:	27	50
Hexadecimal:	1B	32

**Comments:**

Sets the line spacing to 1/6 of an inch for subsequent line-feed commands. The "2" is the *character* two and not ASCII code 2. This is the default at power on.

**ESC 3****Select  $n/216$ -inch Line Spacing****Format:**

ASCII code:	ESC	3	$n$
Decimal:	27	51	$n$
Hexadecimal:	1B	33	$n$

**Comments:**

Sets the line spacing to  $n/216$  of an inch for subsequent line feed commands. The "3" is the *character* three and not ASCII code 3. The value of  $n$  must be from 0-255.

**ESC A****Select  $n/72$ -inch Line Spacing****Format:**

ASCII code:	ESC	A	$n$
Decimal:	27	65	$n$
Hexadecimal:	1B	41	$n$

**Comments:**

Sets the line spacing to  $n/72$  of an inch for subsequent line feed commands. The value of  $n$  must be from 0-85.

**ESC J****Perform  $n/216$ -inch Line Feed****Format:**

ASCII code:	ESC	J	$n$
Decimal:	27	74	$n$
Hexadecimal:	1B	4A	$n$

**Comments:**

Advances the paper  $n/216$  of an inch. The value of  $n$  must be from 0-255. This command produces an immediate line feed but does not affect subsequent line spacing and does not produce a carriage return.

**Vertical tabbing****VT****Tab Vertically****Format:**

ASCII code:	VT
Decimal:	11
Hexadecimal:	0B

**Comments:**

Advances the paper to the next tab setting in the channel selected by ESC /. If no channel has been selected, channel 0 is used. If no vertical tabs have been selected, the paper advances one line.

**ESC B****Set Vertical Tabs****Format:**

ASCII code:	ESC	B	$n1$	$n2$	...	NUL
Decimal:	27	66	$n1$	$n2$	...	0
Hexadecimal:	1B	42	$n1$	$n2$	...	00

**Comments:**

Sets up to 16 vertical tabs in the current line spacing. Tab settings are not affected by subsequent changes in line spacing. The tab settings are entered as  $n1$ ,  $n2$ , etc., all from 1-255, in ascending order. The NUL character indicates the end of the command. All settings are stored in channel 0 (see ESC b). ESC B NUL clears the tab settings.

## ESC b Set Vertical Tabs in Channels

---

### Format:

ASCII code:	ESC	b	c	n1	n2	...	NUL
Decimal:	27	98	c	n1	n2	...	0
Hexadecimal:	1B	62	c	n1	n2	...	00

### Comments:

Functions the same as ESC B, except that the variable *c* selects a channel for the vertical tabs, which must be between 0-7. Therefore, up to eight sets of vertical tabs can be set. The channels are selected by ESC /. To clear the tabs in channel *c* use ESC b c NUL.

## ESC / Select Vertical Tab Channel

---

### Format:

ASCII code:	ESC	/	c
Decimal:	27	47	c
Hexadecimal:	1B	2F	c

### Comments:

This command is used to select the vertical tab channel, with the value of *c* from 0-7. All subsequent VT commands use the channel selected by this command.

## Margins

### ESC l Set Left Margin

---

#### Format:

ASCII code:	ESC	l	n
Decimal:	27	108	n
Hexadecimal:	1B	6C	n

#### Comments:

Sets the left margin to *n* columns in the current pitch. This command clears previous tab settings and all previous characters in the print line. Use lowercase l (for left), not the numeral one. The minimum space between the margins is the width of one double-wide pica character.

**ESC Q****Set Right Margin****Format:**

ASCII code:	ESC	Q	<i>n</i>
Decimal:	27	81	<i>n</i>
Hexadecimal:	1B	51	<i>n</i>

**Comments:**

Sets the right margin to *n* columns in the current pitch. This command clears previous tab settings and all previous characters in the print line. The minimum space between the margins is the width of one double-wide pica character.

**Print head movement****BS****Backspace****Format:**

ASCII code:	BS
Decimal:	8
Hexadecimal:	08

**Comments:**

Prints out data in the print buffer, then moves the print position one space to the left. Backspacing can be performed up to, but not beyond, the left margin setting. The BS code is also ignored if ESC a, 1, 2, or 3 has been sent. If this code is received immediately after graphics printing, the print position of subsequent data cannot be assured.

**ESC e****Set Tab Increments****Format:**

ASCII code:	ESC	e	<i>n</i>	<i>s</i>
Decimal:	27	101	<i>n</i>	<i>s</i>
Hexadecimal:	1B	65	<i>n</i>	<i>s</i>

**Comments:**

This command sets the horizontal or vertical tab increments. When *n* is 0, the horizontal tabs are set at intervals of *s* spaces. Maximum values are 21 in pica, 25 in elite and 36 in condensed text modes. When *n* is 1, the vertical tabs are set to *s* line feeds.

**ESC f****Horizontal/Vertical Skip****Format:**

ASCII code:	ESC	f	n	s
Decimal:	27	102	n	s
Hexadecimal:	1B	66	n	s

**Comments:**

Prints spaces or line feeds without carriage returns. When *n* is 0, *s* spaces will be inserted up to a maximum of 127. If *n* is set to 1, *s* line feeds will be performed.

**Horizontal tabbing****HT****Tab Horizontally****Format:**

ASCII code:	HT
Decimal:	9
Hexadecimal:	09

**Comments:**

Advances the print position to the next horizontal tab setting. The default settings are at intervals of eight characters in the default pitch, and tab positions are not affected by subsequent changes in character pitch.

**ESC D****Set Horizontal Tabs****Format:**

ASCII code:	ESC	D	<i>n1</i>	<i>n2</i>	...	NUL
Decimal:	27	68	<i>n1</i>	<i>n2</i>	...	0
Hexadecimal:	1B	44	<i>n1</i>	<i>n2</i>	...	00

**Comments:**

This command allows setting of up to 32 horizontal tabs, which are entered as *n1*, *n2*, *n3*, etc. (from 1-137) with the NUL character or any value less than the previous one terminating the command. ESC D NUL clears all tabs. The settings on power up or after an ESC @ command are every eight characters. The tab settings do not change if the character pitch is changed.

---

## Overall Printing Style

ESC x

Select NLQ or Draft

---

**Format:**

ASCII code:	ESC	x	n
Decimal:	27	120	n
Hexadecimal:	1B	78	n

**Comments:**

The following values can be used for n:

- 0: Selects the draft mode. (The characters "0" and "1" can also be used.)
- 1: Selects the Near Letter Quality (NLQ) mode.

ESC k

Select NLQ Font

---

**Format:**

ASCII code:	ESC	k	n
Decimal:	27	107	n
Hexadecimal:	1B	6B	n

**Comments:**

This command affects only the Near Letter Quality (NLQ) mode, not draft.

The following values can be used for n:

- 0 = Roman
- 1 = Sans Serif

**ESC !****Master Select****Format:**

ASCII code:	ESC	!	<i>n</i>
Decimal:	27	33	<i>n</i>
Hexadecimal:	1B	21	<i>n</i>

**Comments:**

Selects any valid combination of the modes in the table below. The variable *n* is determined by adding together the values of the desired modes from the table.

*Table A-1. Master Select numbers*

Mode	Dec	Hex
Pica	0	00
Elite	1	01
Condensed	4	04
Emphasized	8	08
Double-strike	16	10
Double-wide	32	20
Italic	64	40
Underline	128	80

Pica cannot be combined with elite, and emphasized cannot be condensed. If both emphasized and condensed are selected, emphasized overrides condensed.

---

**Print Size and Character Width**
**ESC P****Select Pica Pitch****Format:**

ASCII code:	ESC	P
Decimal:	27	80
Hexadecimal:	1B	50

**Comments:**

Selects pica pitch (10 characters per inch). Because pica is the default pitch, this command is normally used to cancel elite.

**ESC M****Select Elite Pitch**

---

**Format:**

ASCII code:	ESC	M
Decimal:	27	77
Hexadecimal:	1B	4D

**Comments:**

Selects elite pitch (12 characters per inch).

**SI****Select Condensed Mode**

---

**Format:**

ASCII code:	SI
Decimal:	15
Hexadecimal:	0F

**Comments:**

Prints characters at about 60 percent of their normal width. For example, the condensed pica mode has 17 characters per inch.

**ESC SI****Select Condensed Mode**

---

**Format:**

ASCII code:	ESC	SI
Decimal:	27	15
Hexadecimal:	1B	0F

**Comments:**

Duplicates the SI command.

**DC2****Cancel Condensed Mode**

---

**Format:**

ASCII code:	DC2
Decimal:	18
Hexadecimal:	12

**Comments:**

Cancels condensed printing set by SI, ESC SI, SelecType, or DIP switch 1-1.

**SO** Select Double-wide Mode (one line)

**Format:**

ASCII code: SO  
Decimal: 14  
Hexadecimal: 0E

**Comments:**

Double-wide mode doubles the width of all characters. This mode is cancelled by a carriage return or DC4.

**ESC SO** Select Double-wide Mode (one line)

**Format:**

ASCII code: ESC SO  
Decimal: 27 14  
Hexadecimal: 1B 0E

**Comments:**

Duplicates the SO command.

**DC4** Cancel Double-wide Mode (one line)

**Format:**

ASCII code: DC4  
Decimal: 20  
Hexadecimal: 14

**Comments:**

Cancels one-line double-wide printing selected by SO or ESC SO, but not double-wide printing selected by ESC W or ESC !.

---

**ESC W** **Turn Double-wide Mode On/Off**

---

**Format:**

ASCII code:	ESC	W	<i>n</i>
Decimal:	27	87	<i>n</i>
Hexadecimal:	1B	57	<i>n</i>

**Comments:**

The following values can be used for *n*:

- 1: The mode is turned ON. (The characters "0" and "1"
- 0: The mode is turned OFF. can also be used.)

Double-wide mode doubles the width of all characters.

---

**Print Enhancement**

---

**ESC E** **Select Emphasized Mode**

---

**Format:**

ASCII code:	ESC	E
Decimal:	27	69
Hexadecimal:	1B	45

**Comments:**

Makes text bolder by printing each dot twice, with the second dot slightly to the right of the first.

**ESC F** **Cancel Emphasized Mode**

---

**Format:**

ASCII code:	ESC	F
Decimal:	27	70
Hexadecimal:	1B	46

**Comments:**

Cancels emphasized, the mode selected by ESC E.

**ESC G****Select Double-strike Mode**

---

**Format:**

ASCII code:	ESC	G
Decimal:	27	71
Hexadecimal:	1B	47

**Comments:**

Makes text bolder by printing each line twice, with the second printing slightly below the first. In NLQ the mode is not available but is not cancelled.

**ESC H****Cancel Double-strike Mode**

---

**Format:**

ASCII code:	ESC	H
Decimal:	27	72
Hexadecimal:	1B	48

**Comments:**

Turns off the double-strike mode selected by ESC G.

**ESC S 0****Select Superscript Mode**

---

**Format:**

ASCII code:	ESC	S	NUL
Decimal:	27	83	0
Hexadecimal:	1B	53	00

**Comments:**

Prints characters about two-thirds of the normal height in the upper part of the character space. The ASCII code 0 or the *character* "0" can be used in this command. It is cancelled with ESC T.

**ESC S 1****Select Subscript Mode****Format:**

ASCII code:	ESC	S	SOH
Decimal:	27	83	1
Hexadecimal:	1B	53	01

**Comments:**

Prints characters about two-thirds of the normal height in the lower part of the character space. The ASCII code 1 or the *character* "1" can be used in this command. It is cancelled with ESC T.

**ESC T****Cancel Superscript/Subscript****Format:**

ASCII code:	ESC	T
Decimal:	27	84
Hexadecimal:	1B	54

**Comments:**

Cancels either superscript or subscript.

**ESC -****Turn Underlining Mode On/Off****Format:**

ASCII code:	ESC	-	<i>n</i>
Decimal:	27	45	<i>n</i>
Hexadecimal:	1B	2D	<i>n</i>

**Comments:**

The following values can be used for *n*:

1: Mode is turned ON. (The *characters* "0" and "1" can also be used.)  
 0: Mode is turned OFF.

This mode provides continuous underlining, including spaces.

---

## Word Processing

ESC a

NLQ Justification

---

**Format:**

ASCII code:	ESC	a	n
Decimal:	27	97	n
Hexadecimal:	1B	61	n

**Comments:**

The following values can be used for n:

- 0: Selects left justification.
- 1: Selects centering.
- 2: Selects right justification.
- 3: Selects full justification.

The default setting is n = 0. Full justification (n = 3) is performed when the buffer becomes full or when one of the following is received: CR, VT, LF, FF. The commands HT and BS are invalid except in n = 0 mode. For n = 3 there must be no carriage returns within a paragraph. Justification can be used in NLQ only, not draft.

---

## Character Sets

ESC t

Select Character Table

---

**Format:**

ASCII code:	ESC	t	n
Decimal:	27	116	n
Hexadecimal:	1B	74	n

**Comments:**

The following values can be used for n:

- 0: Selects italic character set.
- 1: Selects Epson Character Graphics.

Selects which character table is to be used by codes 128-255. Selecting Epson Character Graphics does not disable italic printing. Italic printing can still be selected by ESC 4. Duplicates the function of DIP switch 1-3. Note that the value of n must equal 00 hex or 01 hex; the characters "0" and "1" cannot be used.

**ESC 4****Select Italic Mode**

---

**Format:**

ASCII code:	ESC	4
Decimal:	27	52
Hexadecimal:	1B	34

**Comments:**

Causes characters from the italic character set to be printed.

This command is valid even if the Epson Character Graphics set has been selected by ESC r or DIP switch 1-3, but character graphics cannot be italicized.

**ESC 5****Cancel Italic Mode**

---

**Format:**

ASCII code:	ESC	5
Decimal:	27	53
Hexadecimal:	1B	35

**Comments:**

Cancels the mode selected by ESC 4.

**ESC R****Select an International Character Set****Format:**

ASCII code:	ESC	R	<i>n</i>
Decimal:	27	82	<i>n</i>
Hexadecimal:	1B	52	<i>n</i>

**Comments:**

See Appendix B for more information on international character sets. The following values can be used for *n*:

0=USA	5=Sweden	9=Norway
1=France	6=Italy	10=Denmark II
2=Germany	7=Spain I	11=Spain II
3=UK	8=Japan	12=Latin America
4=Denmark I		

**ESC 6****Printable Code Area Expansion****Format:**

ASCII code:	ESC	6
Decimal:	27	54
Hexadecimal:	1B	36

**Comments:**

Enables the printing of codes 128 through 159 (decimal) as characters, not control codes. See Appendix B for the characters that are printed when this command is used.

**ESC 7****Cancel ESC 6****Format:**

ASCII code:	ESC	7
Decimal:	27	55
Hexadecimal:	1B	37

**Comments:**

This code causes codes 128 through 159 to be treated as control codes. This is the default.

---

## User-defined Characters

**Note:** See Chapter 5 for sample programs and full information on this topic.

---

### ESC & Define User-defined Characters

**Format:**

ASCII code:	ESC	&	NUL	<i>d1</i>	<i>d2</i>	...	<i>dn</i>
Decimal:	27	38	0	<i>d1</i>	<i>d2</i>	...	<i>dn</i>
Hexadecimal:	1B	26	00	<i>d1</i>	<i>d2</i>	...	<i>dn</i>

**Comments:**

This command allows characters to be redefined in the currently selected mode. The variables *d1* and *d2* must be between 58 and 63 (3A through 3F hex).

---

### ESC : Copy ROM into RAM

**Format:**

ASCII code:	ESC	:	NUL	NUL	NUL
Decimal:	27	58	0	0	0
Hexadecimal:	1B	3A	00	00	00

**Comments:**

This code copies the characters in the ROM into RAM so that specific characters can be redefined.

---

### ESC % Select User-defined Set

**Format:**

ASCII code:	ESC	%	<i>n</i>
Decimal:	27	37	<i>n</i>
Hexadecimal:	1B	25	<i>n</i>

**Comments:**

ESC & is required to define the character set before ESC % can be used. For ESC % the following values can be used for *n*:

- 0: Selects the normal set.
- 1: Selects the user-defined set.

---

## Graphics

**Note:** See Chapter 6 for sample graphics programs.

---

### ESC K Select Single-density Graphics Mode

**Format:**

ASCII code:	ESC	K	<i>n1</i>	<i>n2</i>
Decimal:	27	75	<i>n1</i>	<i>n2</i>
Hexadecimal:	1B	4B	<i>n1</i>	<i>n2</i>

**Comments:**

Turns on eight-pin single-density graphics mode (60 dots per inch).  
The total number of columns =  $n1 + (n2 \times 256)$ .

---

### ESC L Select Double-density Graphics Mode

**Format:**

ASCII code:	ESC	L	<i>n1</i>	<i>n2</i>
Decimal:	27	76	<i>n1</i>	<i>n2</i>
Hexadecimal:	1B	4C	<i>n1</i>	<i>n2</i>

**Comments:**

Turns on eight-pin low-speed double-density graphics mode (120 dots per inch). The total number of columns =  $n1 + (n2 \times 256)$ .

---

### ESC Y Select High-speed Double-density Graphics Mode

**Format:**

ASCII code:	ESC	Y	<i>n1</i>	<i>n2</i>
Decimal:	27	89	<i>n1</i>	<i>n2</i>
Hexadecimal:	1B	59	<i>n1</i>	<i>n2</i>

**Comments:**

Turns on eight-pin high-speed double-density graphics mode (120 dots per inch). The total number of columns =  $n1 + (n2 \times 256)$ .

**ESC Z** **Select Quadruple-density Graphics Mode**

---

**Format:**

ASCII code:	ESC	Z	<i>n1</i>	<i>n2</i>
Decimal:	27	90	<i>n1</i>	<i>n2</i>
Hexadecimal:	1B	5A	<i>n1</i>	<i>n2</i>

**Comments:**

Turns on eight-pin quadruple-density graphics mode (240 dots per inch). The total number of columns =  $n1 + (n2 \times 256)$ .

**ESC \*** **Select Graphics Mode**

---

**Format:**

ASCII code:	ESC	*	<i>m</i>	<i>n1</i>	<i>n2</i>
Decimal:	27	42	<i>m</i>	<i>n1</i>	<i>n2</i>
Hexadecimal:	1B	2A	<i>m</i>	<i>n1</i>	<i>n2</i>

**Comments:**

Turns on graphics mode *m*. See Chapter 6 for details on the available modes. The total number of columns =  $n1 + (n2 \times 256)$ .

**ESC ?** **Reassign Graphics Mode**

---

**Format:**

ASCII code:	ESC	?	<i>s</i>	<i>n</i>
Decimal:	27	63	<i>s</i>	<i>n</i>
Hexadecimal:	1B	3F	<i>s</i>	<i>n</i>

**Comments:**

Changes one graphics mode to another. The variable *s* is a character (K, L, Y or Z), which is reassigned to a mode *n* (0-6).

**Format:**

ASCII code:	ESC	^	<i>m</i>	<i>n1</i>	<i>n2</i>
Decimal:	27	94	<i>m</i>	<i>n1</i>	<i>n2</i>
Hexadecimal:	1B	5E	<i>m</i>	<i>n1</i>	<i>n2</i>

**Comments:**

Turns on 9-pin Graphics Mode. For this command the variable *m* defines density of print (0 for single and 1 for double). The total number of columns =  $n1 + (n2 \times 256)$ . This mode requires two data items for each column of print.

## Appendix B

---

### Character Tables

This appendix contains tables of the complete LX-800 character set, including the extra characters for the 13 Epson international character sets. The tables give a printout of each character and the codes in decimal and hexadecimal.

The first two pages of the table cover the standard ASCII character codes from 0 to 127. The remainder of the table shows up to four characters for each code.

Table B-1. LX-800 characters

Decimal	Hex	Character	ASCII name
0	00	NUL	null
1	01		
2	02		
3	03		
4	04		
5	05		
6	06		
7	07	BEL	bell
8	08	BS	backspace
9	09	HT	tab horizontally
10	0A	LF	line feed
11	0B	VT	tab vertically
12	0C	FF	form feed
13	0D	CR	carriage return
14	0E	SO	shift out
15	0F	SI	shift in
16	10		
17	11	DC1	device control 1
18	12	DC2	device control 2
19	13	DC3	device control 3
20	14	DC4	device control 4
21	15		
22	16		
23	17		
24	18	CAN	cancel line
25	19	EM	end of medium
26	1A		
27	1B	ESC	escape
28	1C		
29	1D		
30	1E		
31	1F		

Table B-1, continued

Dec	Hex	Char	Dec	Hex	Char	Dec	Hex	Char
32	20	SP	64	40	@	96	60	'
33	21	!	65	41	A	97	61	a
34	22	"	66	42	B	98	62	b
35	23	#	67	43	C	99	63	c
36	24	\$	68	44	D	100	64	d
37	25	%	69	45	E	101	65	e
38	26	&	70	46	F	102	66	f
39	27	'	71	47	G	103	67	g
40	28	(	72	48	H	104	68	h
41	29	)	73	49	I	105	69	i
42	2A	*	74	4A	J	106	6A	j
43	2B	+	75	4B	K	107	6B	k
44	2C	,	76	4C	L	108	6C	l
45	2D	-	77	4D	M	109	6D	m
46	2E	.	78	4E	N	110	6E	n
47	2F	/	79	4F	O	111	6F	o
48	30	0	80	50	P	112	70	p
49	31	1	81	51	Q	113	71	q
50	32	2	82	52	R	114	72	r
51	33	3	83	53	S	115	73	s
52	34	4	84	54	T	116	74	t
53	35	5	85	55	U	117	75	u
54	36	6	86	56	V	118	76	v
55	37	7	87	57	W	119	77	w
56	38	8	88	58	X	120	78	x
57	39	9	89	59	Y	121	79	y
58	3A	:	90	5A	Z	122	7A	z
59	3B	;	91	5B	[	123	7B	{
60	3C	<	92	5C	\	124	7C	
61	3D	=	93	5D	]	125	7D	}
62	3E	>	94	5E	^	126	7E	~
63	3F	?	95	5F	_	127	7F	DEL

Table B-1, continued

Dec	Hex	Italic set	Italic w/ESC 6	Graphic set	Graphic w/ESC 7
128	80	NUL	à	Ç	NUL
129	81		è	Ù	
130	82		ù	é	
131	83		ò	â	
132	84		ï	ÿ	
133	85		°	à	
134	86		£	ä	
135	87	BEL	ï	ç	BEL
136	88	BS	¿	ø	BS
137	89	HT	Ñ	ø	HT
138	8A	LF	ñ	è	LF
139	8B	VT	π	ÿ	VT
140	8C	FF	π	î	FF
141	8D	CR	À	ì	CR
142	8E	SO	á	À	SO
143	8F	SI	ç	À	SI
144	90		ß	E	
145	91	DC1	ß	æ	DC1
146	92	DC2	Æ	Æ	DC2
147	93	DC3	æ	ô	DC3
148	94	DC4	ø	ö	DC4
149	95		ø	ò	
150	96		·	ó	
151	97		À	ù	
152	98	CAN	Ö	ÿ	CAN
153	99	EM	Ü	ÿ	EM
154	9A		ä	U	
155	9B	ESC	ö	Φ	ESC
156	9C		ü	£	
157	9D		E	¥	
158	9E		é	π	
159	9F		¥	ƒ	

Table B-1, continued

Dec	Hex	Italic set	Italic w/ESC 6	Graphic set	Graphic w/ESC 7
160	A0	SP	SP	á	á
161	A1	!	!	í	í
162	A2	"	"	ó	ó
163	A3	#	#	ú	ú
164	A4	\$	\$	ñ	ñ
165	A5	%	%	Ñ	Ñ
166	A6	&	&	ä	ä
167	A7	.	.	o	o
168	A8	(	(	¿	¿
169	A9	)	)	¡	¡
170	AA	*	*	¡	¡
171	AB	+	+	½	½
172	AC	,	,	¼	¼
173	AD	-	-	i	i
174	AE	.	.	<	<
175	AF	/	/	>	>
176	B0	0	0	⋮	⋮
177	B1	1	1	⋮	⋮
178	B2	2	2	⋮	⋮
179	B3	3	3		
180	B4	4	4		
181	B5	5	5		
182	B6	6	6		
183	B7	7	7		
184	B8	8	8		
185	B9	9	9		
186	BA	:	:		
187	BB	;	;		
188	BC	<	<		
189	BD	=	=		
190	BE	>	>		
191	BF	?	?		

Table B-1, continued

Dec	Hex	Italic set	Italic w/ESC 6	Graphic set	Graphic w/ESC 7
192	C0	@	@	L	L
193	C1	A	A	⊥	⊥
194	C2	B	B	⊥	⊥
195	C3	C	C	⊥	⊥
196	C4	D	D	—	—
197	C5	E	E	+	+
198	C6	F	F	⊥	⊥
199	C7	G	G	⊥	⊥
200	C8	H	H	⊥	⊥
201	C9	I	I	⊥	⊥
202	CA	J	J	⊥	⊥
203	CB	K	K	⊥	⊥
204	CC	L	L	⊥	⊥
205	CD	M	M	=	=
206	CE	N	N	⊥	⊥
207	CF	O	O	⊥	⊥
208	D0	P	P	⊥	⊥
209	D1	Q	Q	⊥	⊥
210	D2	R	R	⊥	⊥
211	D3	S	S	⊥	⊥
212	D4	T	T	⊥	⊥
213	D5	U	U	⊥	⊥
214	D6	V	V	⊥	⊥
215	D7	W	W	⊥	⊥
216	D8	X	X	⊥	⊥
217	D9	Y	Y	⊥	⊥
218	DA	Z	Z	⊥	⊥
219	DB	[	[	■	■
220	DC	\	\	■	■
221	DD	]	]	■	■
222	DE	^	^	■	■
223	DF	—	—	■	■

Table B-1, continued

Dec	Hex	Italic set	Italic w/ESC 6	Graphic set	Graphic w/ESC 7
224	E0	'	'	α	α
225	E1	<i>a</i>	<i>a</i>	β	β
226	E2	<i>b</i>	<i>b</i>	γ	γ
227	E3	<i>c</i>	<i>c</i>	π	π
228	E4	<i>d</i>	<i>d</i>	Σ	Σ
229	E5	<i>e</i>	<i>e</i>	σ	σ
230	E6	<i>f</i>	<i>f</i>	μ	μ
231	E7	<i>g</i>	<i>g</i>	τ	τ
232	E8	<i>h</i>	<i>h</i>	θ	θ
233	E9	<i>i</i>	<i>i</i>	θ	θ
234	EA	<i>j</i>	<i>j</i>	Ω	Ω
235	EB	<i>k</i>	<i>k</i>	δ	δ
236	EC	<i>l</i>	<i>l</i>	θ	θ
237	ED	<i>m</i>	<i>m</i>	θ	θ
238	EE	<i>n</i>	<i>n</i>	ε	ε
239	EF	<i>o</i>	<i>o</i>	π	π
240	F0	<i>p</i>	<i>p</i>	≡	≡
241	F1	<i>q</i>	<i>q</i>	±	±
242	F2	<i>r</i>	<i>r</i>	∇	∇
243	F3	<i>s</i>	<i>s</i>	∇	∇
244	F4	<i>t</i>	<i>t</i>	∫	∫
245	F5	<i>u</i>	<i>u</i>	∫	∫
246	F6	<i>v</i>	<i>v</i>	+	+
247	F7	<i>w</i>	<i>w</i>	∞	∞
248	F8	<i>x</i>	<i>x</i>	°	°
249	F9	<i>y</i>	<i>y</i>	•	•
250	FA	<i>z</i>	<i>z</i>	•	•
251	FB	{	{	√	√
252	FC	/	/	∞	∞
253	FD	}	}	∞	∞
254	FE	~	~	■	■
255	FF	DEL	Ø		

## International Character Sets

Twelve character codes between 35 and 126 can represent more than one character each, depending upon the international character set you select. You can make the choice either by setting DIP switches 1-6 through 1-8 or by using the ESC R command.

The table below shows all 13 character sets, together with the number to use with ESC R to select each one. The DIP switch combinations to select any of the first eight character sets are in Appendix D.

Note that once a character set has been selected, italic versions of these characters can also be printed by using the ESC 4 command.

Table B-2. International characters

	35	36	64	91	92	93	94	96	123	124	125	126
0 USA	#	\$	@	[	\	]	~	~	{		}	~
1 France	#	\$	à	•	ç	ß	~	~	é	ù	è	~
2 Germany	#	\$	ß	Ä	Ö	Ü	~	~	ä	ö	ü	ß
3 UK	£	\$	@	[	\	]	~	~	{		}	~
4 Denmark I	#	\$	@	Æ	Ø	Å	~	~	æ	ø	å	~
5 Sweden	#	¤	É	Å	Ö	Ä	Ü	é	ä	ö	å	ü
6 Italy	#	\$	@	·	\	é	~	ù	à	ò	è	ì
7 Spain I	₧	\$	@	ı	Ñ	¿	~	~	ñ	}	}	~
8 Japan	#	\$	@	[	¥	]	~	~	{		}	~
9 Norway	#	¤	É	Æ	Ø	Å	Ü	é	æ	ø	å	ü
10 Denmark II	#	\$	É	Æ	Ø	Å	Ü	é	æ	ø	å	ü
11 Spain II	#	\$	á	ı	Ñ	¿	é	ı	ı	ñ	ó	ú
12 Latin America	#	\$	á	ı	Ñ	¿	é	ü	ı	ñ	ó	ú

## Appendix C

### Problem Solving and Maintenance

This appendix approaches troubleshooting from several directions. The first section uses a columnar format to match solutions with problems. Other sections cover beeper error warnings, hexadecimal data dumping, coding and 7-bit solutions, and specific solutions for several popular personal computer systems.

#### Problem/Solution Summary

Possible problems are listed on the left and solutions on the right.

Problem	Solution
Printer does not print	<p>Make sure that the printer is turned on and is on line. Both the POWER and ON LINE lights should be on.</p> <p>Make sure that the printer and computer are connected. Be certain you are using the correct cable.</p> <p>If the printer still does not print, try the self test procedure (see Chapter 1). If the self test works correctly, the printer is all right and the problem lies elsewhere. If the self test doesn't work, contact your dealer.</p>

<b>Problem</b>	<b>Solution</b>
Printing is patchy, faint, uneven, or intermittent	<p>Check that the ribbon is seated correctly.</p> <p>Check that the ribbon moves freely in the cartridge.</p> <p>If you have been using the ribbon for a long time or for a large amount of printing, it may need to be replaced.</p> <p>It is also possible for the print head to wear out if the printer is used frequently and for long periods at a time. See the instructions on replacing the print head at the end of this appendix.</p>
All the text is printed on the same line or text is printed with an extra blank line between	This can usually be corrected by changing the setting of DIP switch 2-4. If that does not solve the problem, you may need a different cable.
Some of the characters printed do not match those in the file.	If they are international characters, check the settings of DIP switches 1-6 to 1-8. If they are graphics characters, see that your software is correctly installed and that you have correctly set DIP switch 1-3.
Can't get condensed print	<p>Cancel emphasized mode; it has priority over condensed.</p> <p>Cancel NLQ mode; it has priority over condensed.</p>
Horizontal tabs don't work	Set margins before tabs, not after.
Horizontal tabs are incorrect when changing pitch	Tabs are set according to current print pitch. Changes in pitch do not affect the position of the tabs on the page.

Problem	Solution
Strange things print in graphics mode	<p>Some systems require a WIDTH statement. See your system documentation.</p> <p>Many computers have problems sending one or more of the codes between 0 and 13. Avoid any that affect your system if possible.</p> <p>Seven-bit computers cannot use the eighth pin (128). If you have a 7-bit computer and any of your graphics data numbers are larger than 127, change the design so that all numbers are less than 128.</p> <p>Be sure that no other commands or carriage returns come between the graphics command and its data.</p>
Printer freezes in graphics mode	<p>The printer expects a certain number of pin patterns, determined by <math>n1</math> and <math>n2</math>. It does not print until the quota is full. Note that 9-pin graphics mode requires two bytes for each column of graphics.</p>
Can't get a full page in width	<p>Some systems require a WIDTH statement. See your system documentation.</p>

Problem	Solution
Can't deactivate paper-out sensor with either DIP switch 1-4 or ESC 8	Computer systems that monitor printer cable pin 12 ignore both ESC 8 and the setting of switch 1-4. These systems stop the printing when no paper is in contact with the paper-end detector (a small switch located behind the platen). Certain printer cables are designed to overcome this problem, or you can use a longer page as a backing sheet.

---

## Beeper Error Warnings

When the LX-800's beeper sounds, it usually indicates that the printer is out of paper. The beeper can also be sounded by any program that sends the ASCII code 7 and by certain error conditions in the printer itself.

If the printer beeps and stops printing when it is not out of paper, turn the printer off and check to see that the paper is loaded correctly. If the paper is loaded correctly, turn the printer back on and try to print again. If the printer beeps and does not print again, take it to a qualified service person.

---

## Data Dump Mode

The LX-800 has a special feature that makes it easy for experienced printer users to find the causes of problems. Called the data dump mode, it gives a printout of exactly what codes reach the printer.

To turn on this mode, turn on the printer while holding down both the FORM FEED and LINE FEED buttons. The printer responds by printing the words "Data Dump Mode." Then, when you run a program, either an application program or one you have written in any programming language, the LX-800 prints one or more lines. Each line has three parts: the line number (four digits), the hexadecimal codes (up to 16 numbers), and the guide section (16 characters at the end of each line except the last).

The hexadecimal numbers are the codes received by the printer, and the guide section helps you find a certain place in the list of codes. Each character in the guide section corresponds to one of the codes. If the code is for a printable character, that character is printed. If the code is for a non-printable character, such as ESC or the code for a line feed or carriage return, a dot is printed.

Therefore, if you run the following BASIC program while your LX-800 is in the data dump mode, you get the printout below it. The printer prints all but this last line and then stops. Press the ON/OFF LINE button to make the printer print the last line.

```
10 FOR X=70 TO 73
20 LPRINT CHR$(X): NEXT X
30 LPRINT CHR$(27)"E"
40 LPRINT "Sample text"
50 LPRINT CHR$(27)"@"
```

Data Dump Mode

```
0000 46 0D 0A 47 0D 0A 48 0D 0A 49 0D 0A 1B 45 0D 0A F..B..H..I...E..
0001 53 61 6D 70 6C 65 20 74 65 78 74 0D 0A 1B 40 0D Sample text...@
0002 0A
```

You can consult Appendix A or the Quick Reference card to see the meaning of the hexadecimal codes. Here is an explanation of the first line to put you on the right track for using the data dump mode.

The first code in line 0000 is hex 46, which is the same as decimal 70, which is the code for "F"; therefore "F" is printed in the first position in the guide section. Then, because there is no semicolon in line 20, BASIC sends a carriage return and a line feed, hex codes 0D and 0A. Each of these is represented by a dot in the guide section. The program then sends the hex codes 47, 48, and 49, with each followed by a carriage return and line feed.

When the program gets to line 30, it sends ESC E and a carriage return and line feed. These are hex codes 1B, 45, 0D, and 0A, which are represented in the guide section by a dot, an "E," and two more dots.

Now you can follow a data dump printout on your own.

Some computer systems change one or more codes when sending them from BASIC to the printer. The ability of the LX-800 to dump in hexadecimal lets you determine which codes are creating problems for your system.

A hex printout of a program shows you exactly what the printer is receiving, regardless of what the computer is sending. The following test program lets you check to see which codes, if any, are problems for your computer system.

```
10 FOR X=0 TO 255
20 LPRINT CHR$(X);
30 NEXT X
```

Put the printer in data dump mode and then run the program. Remember to press the ON/OFF LINE button to make the LX-800 print the final line. Then compare your printout with the list of hex codes in order in Appendix B. If any are skipped or repeated, you know that your BASIC language changes some codes before it sends them to the printer.

For example, the line below is the first line of the printout of the test program run on a system that changes hex 09, which is the code for horizontal tabbing, to several 20s, the code for a space. Therefore, you know that if you use this system, you must be careful about sending a decimal 9 (hex 09).

```
0000 00 01 02 03 04 05 06 07 08 20 20 20 20 20 20 20 .....
```

The data dumping capability can help you solve problems quickly. Appendix B can help you translate the hex codes to ASCII equivalents.

---

## Coding Solutions

Once you've determined that a code creates problems for your printing, either by trial and error or by using the data-dumping capability of the LX-800, you can start overcoming them.

Because each computer system deals with ASCII codes differently, it is impossible to provide solutions for all potential problems in one appendix. It may help, however, to be aware of some generic problems and some ways to handle them.

There are four common approaches. First, you may be able to buy an alternative interface board for your system. This is the best solution for 7-bit system problems. See your computer dealer for advice about this.

The second approach is to use commercially available software that is specifically designed to overcome these coding problems. Consult your computer dealer or computer publications to see if a program for your computer system is available.

The third approach is to avoid the software that is changing the codes. On most computers you can send each code directly to the printer port. This bypasses the BASIC interpreter and avoids the interface.

Unfortunately, this process is also different for each computer system. Consult your computer's manual to determine if you can do the same on your system.

A fourth approach is to change the printer driver program in your system. This requires a knowledge of machine language and of the way your computer works. If you don't have this knowledge, your computer dealer may be able to help you or recommend someone who can.

---

## Solutions for Specific Systems

The next four subsections illustrate dealing with interface puzzles on four types of computers.

### Applesoft BASIC solutions

Applesoft BASIC does not use PRINT to send data to the screen and LPRINT to send data to the printer as Microsoft BASIC does. Therefore, put a PR#1 at the beginning of a program and change all instances of LPRINT to PRINT.

If one of the example programs contains an INPUT statement or a PRINT statement, a message should go to the screen before anything is sent to the printer. In these programs, leave the first lines as they are and after the INPUT and/or PRINT statements, add a line that states PR#1. Then change all the instances of LPRINT to PRINT and put a line that states PR#0 at the end of the program.

## Apple® II solutions

Apple II computers pose two types of problems. The first is that the Apple II is an 8-bit computer, but its printer interface handles only seven bits. The second is that there is one problem code number: nine.

The printer interface card furnished with the Apple II computer passes only seven bits to the LX-800, which means that you have a 7-bit system. Should you need an 8-bit system, the simplest solution is to purchase a new printer interface card from your computer dealer. Such a card is available for the Apple II.

The Apple II uses CHR\$(9) to initialize the printer. This code and the following character or characters are intercepted by the printer interface card and used to change modes. You can divert all output to the printer instead of to the screen by sending the following line to the printer.

```
PR#1  
PRINT CHR$(9)"80N"
```

Then type anything, followed by **RETURN**.

The CHR\$(9)"80N" code directs all subsequent output to the printer, up to 80 characters per row. You can cancel this by typing:

```
PRINT CHR$(9)"I" or PR#0
```

The problem is that the LX-800 uses CHR\$(9) to activate horizontal tabulation and can also use it in graphics programs. When you send this code, however, your system interprets it as a printer initialization code and the program does not work properly. In these cases, use the following method to change your printer initialization code to a number that is not used in the program. For example, you can change your initialization code to one by typing:

```
PR#1  
PRINT CHR$(9); CHR$(1)
```

## IBM-PC solutions

There are two problems using the IBM Personal Computer BASIC to drive a printer. First, the IBM-PC BASIC inserts a carriage-return/line-feed (CR-LF) after each 80 characters you send it. Second, it adds an LF to each CR in an LPRINT statement.

Here is the way to adjust the width when it is the only problem. Tell the computer that the print line is wider than 80 characters with this WIDTH statement:

```
WIDTH "LPT1:", 255
```

The 255 is a special number that prevents the computer system from inserting a CR-LF into the line—unless, of course, there's one in your program.

The extra line feed—CHR\$(10)—that accompanies each carriage return—CHR\$(13)—does not cause a problem unless you need to use CHR\$(13) in a graphics program. Getting rid of the extra CHR\$(10) is rather complicated. First you open the printer as a random file:

```
OPEN "LPT1:" AS #1
```

Although this allows you to send any code to the printer, you can no longer use the LPRINT command. Instead, you must use a PRINT #1 command:

```
PRINT #1, "Now I can print anything"
```

This does allow you to print anything, but it ignores any previous WIDTH statement.

If you want to print more than 80 characters per line in a graphics program, you must change your opening statement to include the appropriate WIDTH statement:

```
OPEN "LPT1:" AS #1 : WIDTH #1, 255
```

And for the programs in this manual, don't forget to use PRINT #1 wherever you see LPRINT.

---

## Maintaining Your Printer

Always keep the printer in a clean and safe place. Keep it away from dust, grease, moisture and any source of heat, including direct sunlight. A safe temperature range is 40° F to 95° F (5° C to 35° C).

If the outer case is dirty, clean it with a soft, clean cloth dampened with mild detergent dissolved in water. Keep the printer lid in place to prevent any water from getting inside the printer. Do not use a hard

brush or cloth, and never use alcohol or a thinner to clean the printer because it could damage the print head and the case.

Do not spray the inside of the printer with oil: unsuitable oils can damage the mechanism. If lubrication is needed, contact your Epson dealer.

### **The print head**

Be particularly careful with the print head. Never move it when the printer is turned on. When the printer is printing, the print head becomes hot. If you need to change the ribbon or load continuous paper, turn the printer off and wait for a few minutes while the print head cools down.

Each pin on the print head should last about 200 million strokes. When the print head fails, one or more of the pins may fire erratically or stop firing completely, making the printout patchy. If this happens suddenly or long before the expected lifetime is over, the problem is almost certainly connected with another component of the printer.

### **Replacing the print head**

As soon as the print head fails, stop using the printer and contact your Epson dealer for a replacement head. The catalog number is #8732.

To replace the head, follow these steps:

1. Turn the printer OFF.
2. If the printer has been recently used, the print head will be hot. Let it cool.
3. Open the printer lid.
4. Remove the ribbon.
5. Release the head lock levers. (See Figure C-1.)

Figure C-1.  
Releasing the print head lock levers

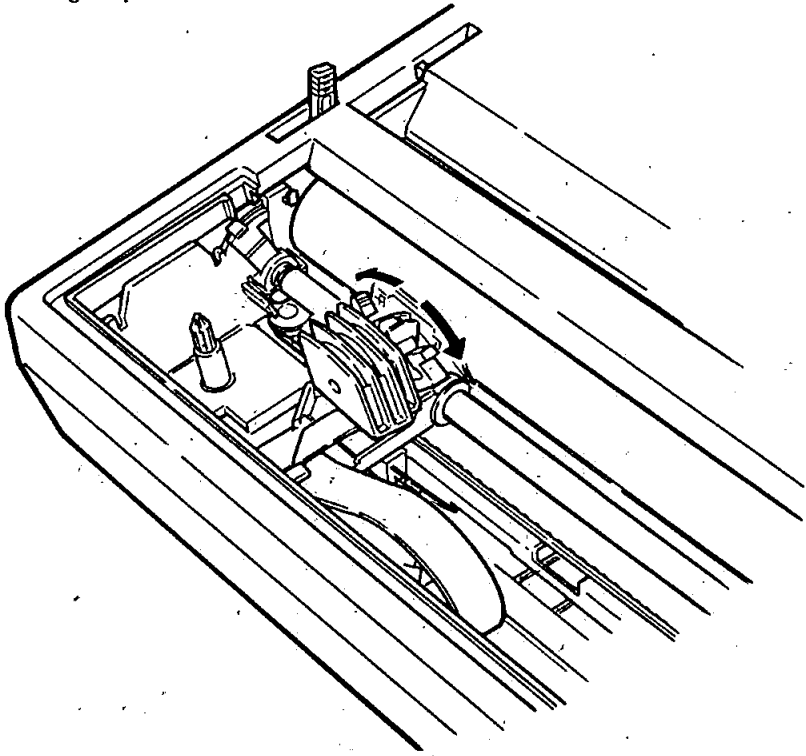

6. Lift the print head from its position and carefully disconnect the flat cable from the print head, as shown in Figure C-2.

Figure C-2.  
*Disconnecting the cable*

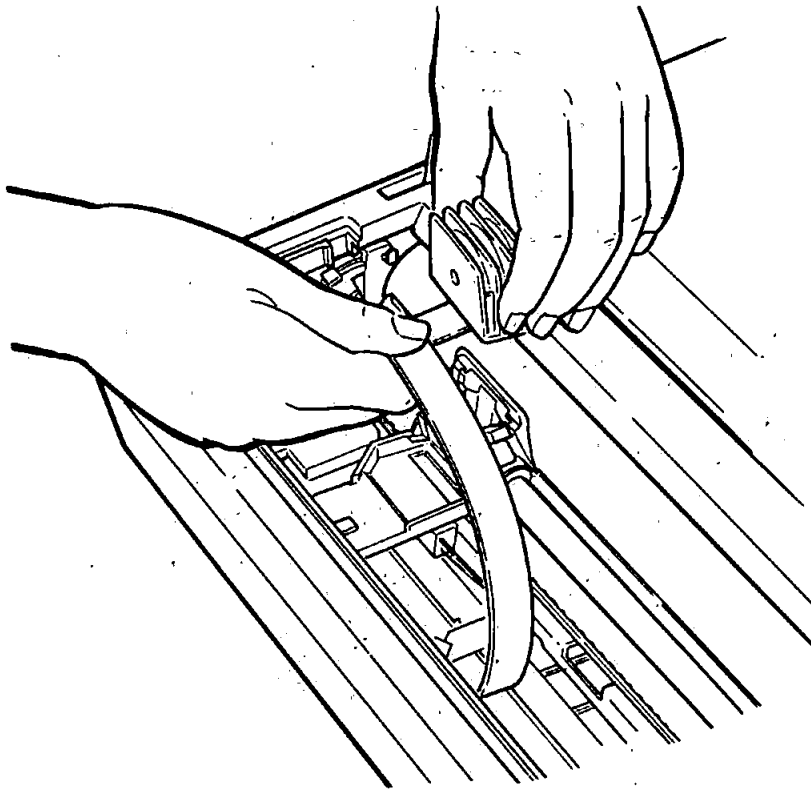

7. Connect the new print head to the flat cable, and place the new print head in the head mount, as shown in Figure C-3. Be sure to tuck the flat cable into the cable support as shown in the figure.

Figure C-3.  
*Installing the new print head*

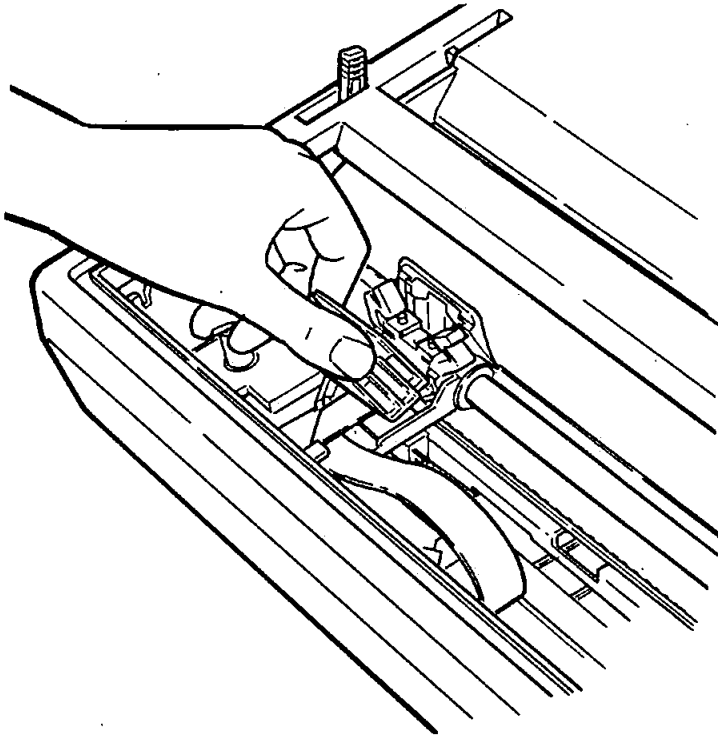

8. Move the head lock levers back to their original positions.  
Now your new print head is ready to use.



### Defaults and DIP Switches

This appendix lists the default settings and lists and explains the settings of all the DIP switches.

---

#### Default and Initialization Settings

The LX-800 can be initialized (returned to a fixed set of conditions) in three different ways: when it is turned on, when it receives an INIT signal at the parallel interface (pin 31 becomes LOW), and when it receives the ESC @ command.

The following conditions are always reset:

- The print head returns to the home position.
- Interface signals are reset, and the printer is put on line.
- The current print line is cleared.
- Margins and vertical tab settings are cleared, line spacing is set to 1/6-inch, horizontal tabs are set at every eighth position and vertical tab channel 0 is selected.
- The page length and skip-over-perforation are set according to DIP switches 2-1 and 2-3, and the top of form position is set to the current line.
- The ROM characters are selected, and the Epson mode character table and international character set are reset according to DIP switches 1-3 and 1-6 to 1-8.

In addition, when the printer is initialized by turning on the power or by an INIT signal, the data buffer is cleared of all text.

ESC @ resets the typestyle to the current SelecType settings, but the other two methods reset the typestyle according to the DIP switches. Also, ESC @ does not check whether any DIP switches have been altered since the printer was turned on; instead, it uses the old settings.

---

## DIP Switch Settings

The LX-800 has twelve DIP (Dual In-line Package) switches that allow you to change many of the printer's settings to suit your individual needs. The DIP switches are in two groups, mounted on the back panel, as shown in Figure D-1.

---

Figure D-1.  
DIP switch location

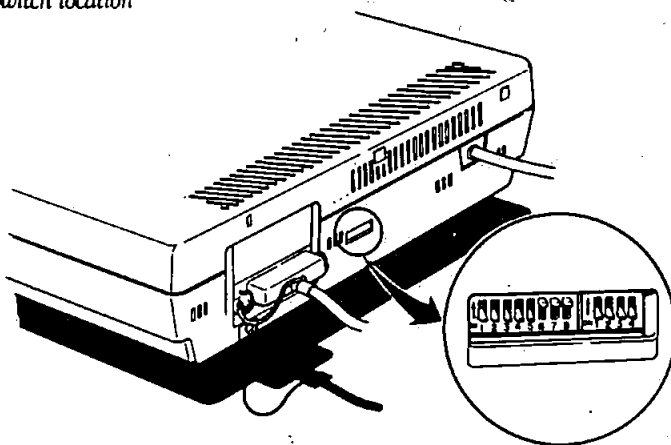

DIP switch 1-1 is the switch at the far left side and the one at the far right is DIP switch 2-4. You can easily reset the switches with a thin, pointed object such as a small screwdriver or the cap of a ballpoint pen.

---

### Note

When you change a DIP switch setting, turn off the power, reset the switch or switches, then turn on the power again. The printer checks and recognizes new settings only at the time the power is turned on.

---

The following tables describe the switches and their functions.

The first two tables summarize the two groups of switches. The remaining table shows how to set the DIP switches for the available international character sets.

Table D-1. DIP switch group 1

Switch number	Function	Action when ON	Action when OFF
1-1	Select condensed or normal characters	Condensed	Normal
1-2	Select slashed or unslashed zero	0	0
1-3	Select character table	Graphics	Italics
1-4	Paper-out detection	Inactive	Active
1-5	Select print quality	NLQ	Draft
1-6 1-7 1-8	Select international character set	See Table D-3	

Table D-2. DIP switch group 2

Switch number	Function	Action when ON	Action when OFF
2-1	Select page length	12 inch	11 inch
2-2	Select cut sheet feeder mode	Selected	Not selected
2-3	Skip-over-perforation	1 inch	None
2-4	Add line feed after carriage return	CR + LF	CR only

**Note:** The factory setting for all switches except 1-6, 1-7, and 1-8 is OFF.

## International Character Sets

Thirteen international character sets are available in Epson mode. Eight of these are selected by DIP switches 1-6 to 1-8 and the remaining five (Japan, Norway, Denmark II, Spain II and Latin America) can be selected with the ESC R command, which is described in the Command Summary (Appendix A). For the characters available in each character set, see Appendix B.

The DIP switch settings to select the different character sets are shown in Table D-3.

*Table D-3. International settings*

Character set	DIP switch settings		
	1-6	1-7	1-8
USA	ON	ON	ON
French	ON	ON	OFF
German	ON	OFF	ON
UK	ON	OFF	OFF
Danish	OFF	ON	ON
Swedish	OFF	ON	OFF
Italian	OFF	OFF	ON
Spanish	OFF	OFF	OFF



---

## Installing an Interface

Before installing an interface, you must remove the printer's cover.

---

### WARNING

Do not remove the cover unless the printer is turned OFF and disconnected because high voltages are present inside the printer when the power is on. Also, do not touch contacts on the circuit board of the printer because many of the components can be destroyed by the static electricity charge that may build up on your body.

---

1. Turn off the power to both the printer and the computer and unplug the power cable and disconnect the interface cable from the printer.
2. Remove the printer lid, tractor unit (if installed), paper rest (if installed), and paper guide.
3. Remove the cut sheet feeder if one is installed.
4. Remove the ribbon.
5. To remove the upper case of the printer, insert a blade screwdriver into each of the two holes at the front of the printer, as shown in Figure E-1. Gently twist the screwdriver while pushing it up until the upper case is loosened from the bottom.

Figure E-1.  
Removing the cover

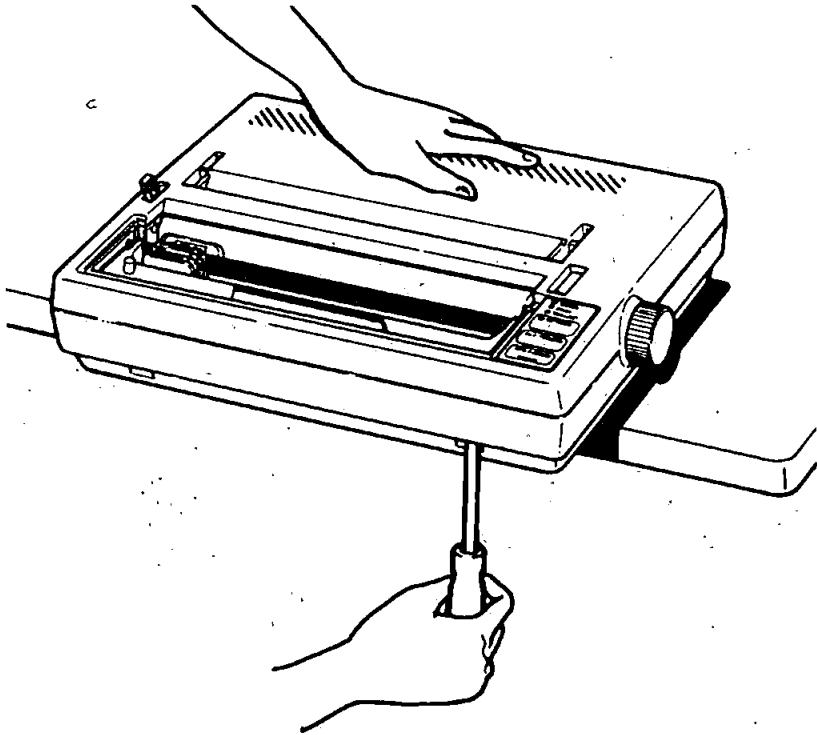

6. Slightly raise the upper case by its front. As you do this, be careful not to pull the flat cable out of the control panel in the upper case.

7. Disconnect the other end of the flat control panel cable from the main circuit board connector. See Figure E-2.

Figure E-2.

*Disconnecting the control panel cable*

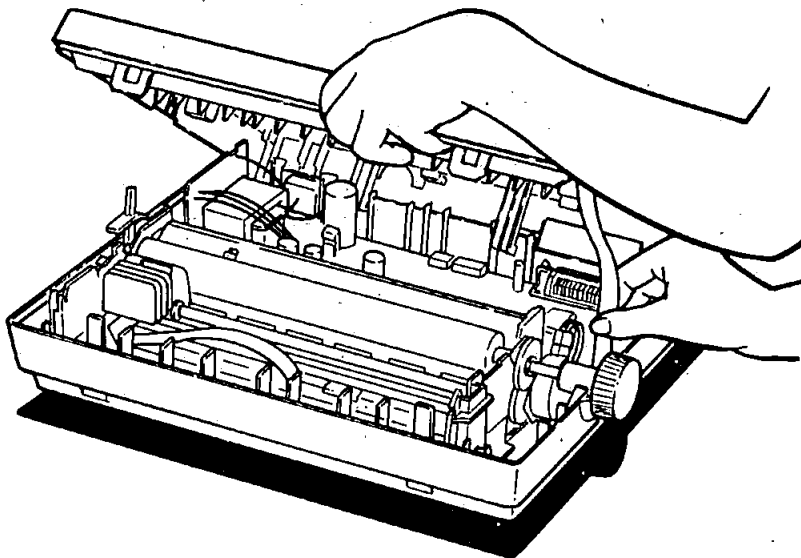

After you remove the case, follow the instructions below to insert the interface board. After you have inserted the board, replace the case by reversing steps 2 through 7.

## Inserting the interface board

1. Locate the connector cover at the back of the upper case, shown in Figure E-3. Push it down and in, toward the inside of the printer, until it clicks. You need to move the cover to allow access to the new interface connector when the case is re-assembled.

Figure E-3.  
Connector cover

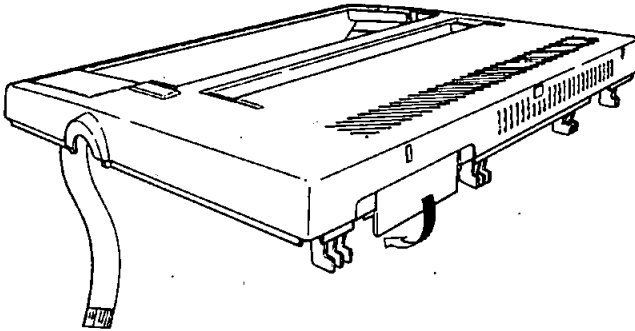

2. The screw marked CG at the rear of the circuit board is the connection for the frame ground wire. Unscrew it and then use it to connect the frame ground wire as shown in Figure E-4.

Figure E-4.  
Connecting the frame ground wire

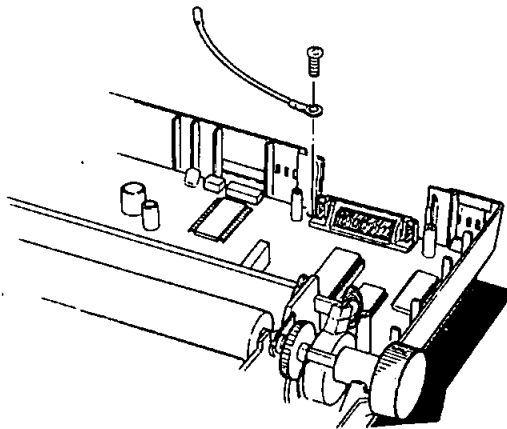

3. Plug the interface board into the connector marked CN2 on the main circuit board of the printer.
4. Secure the board to the three supports with the screws provided, as shown in Figure E-5.

Figure E-5.  
Securing the board

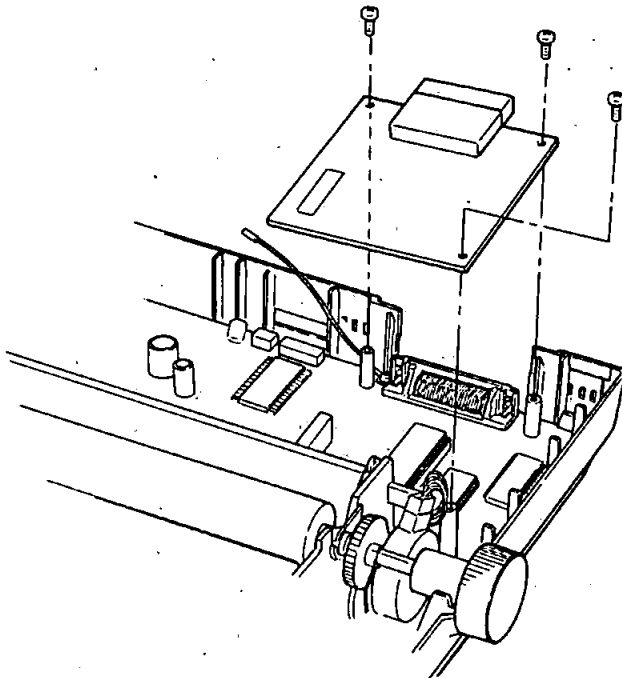

5. Connect the frame ground wire to the FG terminal tag on the interface board, as shown in Figure E-6.

Figure E-6.

Connecting ground wire to FG terminal tag

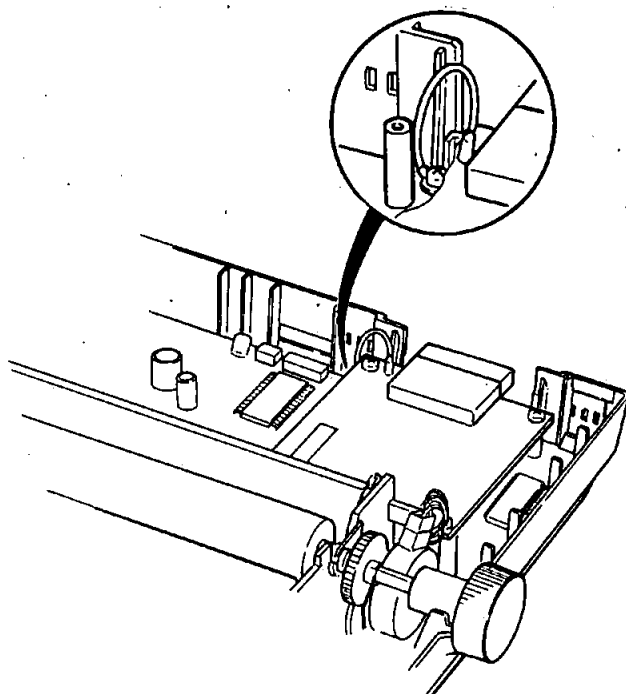

6. Reassemble the printer, reversing the procedure described in steps 2 through 7 in the previous section.

---

## Serial Interface Settings

If you are using an optional serial interface, you may need to change the communications protocol of the printer or the computer for them to communicate properly. The protocol used by the printer is decided by one or two groups of DIP switches located on the serial interface board; the protocol used by the computer can probably be altered by a software command. It is essential that the printer and computer use compatible protocols.

If you can, change the settings on the computer rather than the interface board because the interface is set up at the factory to give optimum performance in a wide range of conditions. If your dealer has installed the interface for you, he or she should also be able to adjust the computer and interface to achieve a good match.

If you do need to change the settings on the interface yourself, (perhaps in order to use a different computer), refer to the manual supplied with the interface.

## Appendix F

### Technical Specifications

---

This appendix contains the specifications for the LX-800, including the built-in parallel interface.

---

#### Printing

Printing method  
Impact dot matrix

Printing speed  
180 characters per second in draft elite  
150 characters per second in draft pica  
25 characters per second in NLQ pica

Printing direction  
Bidirectional logic-seeking for text printing  
Unidirectional for graphics and available by software command for text

Character sizes  
All except superscript and subscript are 3.1 mm high. The widths and characters per inch (CPI) are given below:

Mode	Width (mm)	CPI	Mode	Width (mm)	CPI
Pica	2.1	10	Condensed Pica	1.05	17
Elite	2.1	12	Condensed Elite	1.05	20

Line spacing  
1/6-inch, or programmable in increments of 1/216th of an inch

---

#### Paper

Number of copies  
One original plus two copies; total thickness not to exceed 0.01 in. (0.25 mm)

Paper width  
Continuous feed: 4 to 10 in.  
Single-sheet: 7.15 to 8.5 in.

---

## Mechanical

### Ribbon

Cartridge, black #8750 (uses the same ribbon as the Epson FX printers)

Life expectancy (in characters, at 14 dots/character): 3 million

### MCBF

3 million lines (excluding the print head)

### MTBF

4,000 hours

### Print head life

200 million strokes per needle

### Dimensions and Weight

Height (excluding tractor): 3.5 in.

Width (with paper feed knob): 15.7 in.

Depth: 12.1 in.

Weight (including tractor): 11.2 lbs.

---

## Electrical

### Voltage

120V AC

### Power consumption

70 VA maximum

### Frequency

49.5 Hz – 60.5 Hz

### Insulation resistance

10 Mohms between AC power line and chassis

### Dielectric strength

Can withstand 1 kV rms applied between AC line and chassis for 1 minute, or 1.20 kV rms for 1 second

## Environment

### Temperature

Operation: 41° F to 95° F (5 C° to 35 C°)  
Storage: -22° F to 149° F (-30 C° to 60 C°)

### Humidity

Operation: 10% to 80% without condensation  
Storage: 5% to 85% without condensation

### Shock

Operation: Up to 1 G within 1 ms  
Storage: Up to 2 G within 1 ms

### Vibration

Operation: Up to 0.25 G at up to 55 Hz  
Storage: Up to 0.5 G at up to 55 Hz

## Parallel Interface

Connector pin assignments and a description of respective interface signals are shown in Table F-1.

Table F-1. Pins and signals

Signal Pin	Return Pin	Signal	Direction	Description
1	19	STROBE	IN	STROBE pulse to read data in. Pulse width must be more than 0.5 microseconds at the receiving terminal.
2	20	DATA 1	IN	These signals represent information of the 1st to 8th bits of parallel data, respectively. Each signal is at HIGH level when data is logical 1 and LOW when it is logical 0.
3	21	DATA 2	IN	
4	22	DATA 3	IN	
5	23	DATA 4	IN	
6	24	DATA 5	IN	
7	25	DATA 6	IN	
8	26	DATA 7	IN	
9	27	DATA 8	IN	
10	28	ACKNLG	OUT	Approximately, 12-microsecond pulse. LOW indicates that data has been received and that the printer is ready to accept more data.

Table F-1. Pins and signals continued

Signal Pin	Return Pin	Signal	Direction	Description
11	29	BUSY	OUT	A HIGH signal indicates that the printer cannot receive data. The signal goes HIGH in the following cases: 1) During data entry (ea. char. time) 2) During printing 3) When off line 4) During printer-error, state.
12	30	PE	OUT	A HIGH signal indicates that the printer is out of paper.
13	—	—	—	Pulled up to + 5 volts through 3.3K ohm. resistance.
14	—	AUTO FEED XT	IN	When this signal is LOW, the paper is automatically fed 1 line after printing. (The signal level can be fixed to this by setting DIP switch 2-4 to ON.)
15	—	NC	—	Unused.
16	—	0V	—	Logic ground level.
17	—	CHASSIS GND	—	Printer's chassis ground, which is isolated from the logic ground.
18	—	NC	—	Unused.
19 - 30	—	GND	—	Twisted-pair return signal ground level.
31	—	INIT	IN	When this level becomes LOW, the printer controller is reset to its power-up state and the print buffer is cleared. This level is usually HIGH; its pulse width must be more than 50 microseconds at the receiving terminal.
32	—	ERROR	OUT	This level becomes LOW when the printer is in: 1) Paper-end state 2) Off line state 3) Error state.
33	—	GND	—	Same as for Pins 19 - 30.
34	—	NC	—	Unused.
35	—	—	—	Pulled up to + 5V through 3.3K ohm resistance.
36	—	SLCT IN	IN	The DC1/DC3 code is valid only when this signal is "HIGH". (Internal fixing can be carried out with Jumper J1. The level of this signal is factory set to "LOW".)

**Notes:**

1. The column heading "Direction" refers to the direction of signal flow as viewed from the printer.

2. "Return" denotes the twisted-pair return, to be connected at signal ground level. For the interface wiring, be sure to use a twisted-pair cable for each signal and to complete the connection on the return side. To prevent noise, these cables should be shielded and connected to the chassis of the host computer or the printer but not at both ends.
3. All interface conditions are based on TTL level. Both the rise and the fall times of each signal must be less than 0.2 microseconds.
4. Data transfer must be carried out by observing the ACKNLG or BUSY signal. (Data transfer to this printer can be carried out only after receipt of the ACKNLG signal or when the level of the BUSY signal is LOW.)

## Data Transfer Sequence

### Interface timing

Figure F-1 shows the timing for the parallel interface.

### Printing enabled/disabled signals and control conditions

Table F-2 on the next page shows the relationship between printing being enabled or disabled, and the on line/off line condition, the printer select signal (SLCT IN), and the receipt of data on/off control character, DC1/DC3.

Figure F-1.  
Parallel interface timing

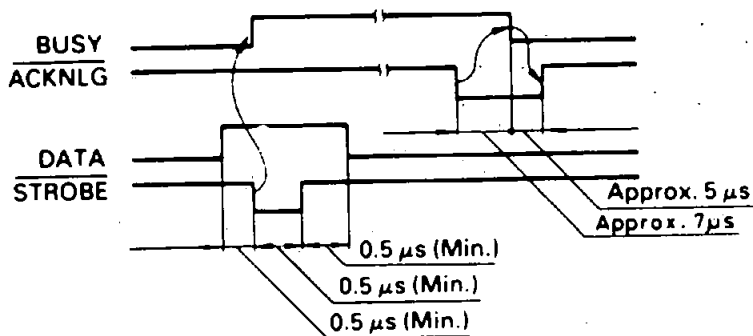

Table F-2. Printing enabled/disabled signals and control conditions

On Line (Indicator on)	SLCT IN	DC1/DC3 (Data on/off contr.)	ERROR	BUSY	ACKNLG	Printing (Disabled/enabled)
ON LINE	LOW (Jumper J1/interface)	DC1/DC3 (no effect)	HIGH	HIGH/LOW	PULSED EA. CHAR.	ENABLED (normal cond.)
ON LINE	HIGH	DC1 RECV'D	HIGH	HIGH/LOW	PULSED EA. CHAR.	ENABLED
ON LINE	HIGH	DC3 RECV'D	HIGH	HIGH/LOW	PULSED EA. CHAR.	*DISABLED
OFF LINE	HIGH/LOW (no effect)	DC1/DC3 (no effect)	LOW	HIGH	NOT GENERATED	DISABLED

\*Even though printing is disabled, data characters are received and acknowledged, since the printer is looking for another DC1 character, which would allow it to resume printing.

# Index

Command descriptions are not indexed here. For page references for specific commands, see pages A-4-6 or the Quick Reference card.

## A

American Standard Code for Information Interchange, 2-2  
ASCII, 2-2  
AUTO LOAD, 1-17-19, 1-21  
Automatic paper loading, 1-17-19

## B

BASIC, 2-6-7  
Baud rate. *See* Interfaces, optional  
Beeper, C-4  
Buttons, 1-20-21

## C

Cable, 1-2, 1-23-24  
Carbon copies, 1-19  
Centronics, 1-2, 1-23  
Character graphics, 4-4.  
*See also* Character tables  
Character tables, B-1-8  
Commands, 2-2-7, 4-1-5, A-1-32  
Commands  
by function, A-7-32  
in numerical order, A-4-6  
Computer-printer  
communication, 2-2-3  
connection, 1-23-24  
Condensed, 3-2, 4-2-3

Connecting printer to computer, 1-23-24  
Continuous-feed paper, 1-2, 1-7-15  
Control codes, 2-2.  
*See also* Commands  
Control keys, A-3  
Control panel, 1-19-22

## D

Data dump, C-4-6  
Defaults, D-1  
DIP switches, 4-1-2, 4-4, D-2-4  
Dot graphics, 2-6, 6-1-12  
Double-strike, 3-2, 4-3  
Double-wide, 4-2-3  
DRAFT/LINE FEED button, 1-21  
Draft mode, 1-20-22, 4-1

## E

Edge guides, 1-12-13, 1-16-17  
Elite, 3-2, 4-2  
Emphasized, 3-2, 4-3  
Epson Character Graphics, 4-4.  
*See also* Character tables  
Escape code (ESC), 2-2.  
*See also* Commands

## F

Foreign language characters.  
See International character sets  
FORM FEED button, 1-21

## G

Graphics, 2-6; 6-1-12

## H

Head. See Print head  
Hexadecimal, 2-2-3

## I

Indicator lights, 1-20  
Initialization, D-1  
Interface board, 1-2.  
See also Interfaces, optional  
Interface, parallel, 1-2, 1-23;  
F-3-6  
Interfaces, optional, E-1-8  
International character sets,  
4-4, B-8, D-3-4  
Italics, 4-4. See also Character tables

## L

Lights, indicator. See Indicator lights  
LINE FEED button, 1-21

## M

Maintenance, C-9-13  
Multi-part forms, 1-19

## N

Near Letter Quality (NLQ) mode,  
1-20-22, 4-1  
NLQ/Form Feed button, 1-21

## O

ON LINE light, 1-20  
ON/OFF LINE button, 1-21

## P

Panel. See Control panel  
Paper. See Continuous-feed  
paper or Single-sheet paper  
Paper feed knob, 1-1, 1-3  
Paper guide, 1-7, 1-12-14,  
1-15-17  
PAPER OUT light, 1-20  
Paper release lever, 1-9, 1-17  
Paper rest, 1-7-8  
Paper thickness lever, 1-19  
Parallel interface. See Interface, parallel  
Pica, 4-2  
Pin feed holders, 1-11-12  
Pitch, 4-2  
POWER light, 1-20  
Printer commands, 2-2-7.  
See also Commands  
Printer selection menu, 2-1-2  
Print head, 1-4, 6-2-3,  
C-10-13  
Problem-solving, C-1-9  
Programming languages, 2-6-7

## R

READY light, 1-20  
Ribbon, 1-3-6  
Ribbon guide, 1-5  
Roman 1-21, 4-1

## S

Sans Serif, 1-21, 4-1  
SelecType, 3-1-4  
Self test, 1-21-22  
Serial interface. *See* Interfaces, optional  
Single-sheet paper, 1-15-19  
Software commands. *See* Commands  
Specifications, F-1-6  
Spreadsheets, 2-4-6  
Subscripts, 4-3  
Superscripts, 4-3

## T

Technical specifications, F-1-6  
Top of form, 1-14-15  
Tractor unit, 1-7-10, 1-15.  
*See also* Continuous-feed paper  
Tractor unit slot cover, 1-7-8  
Troubleshooting, C-1-9

## U

Underlining, 4-3  
User-defined characters, 5-1-12

## W

Word processors, 2-3-4



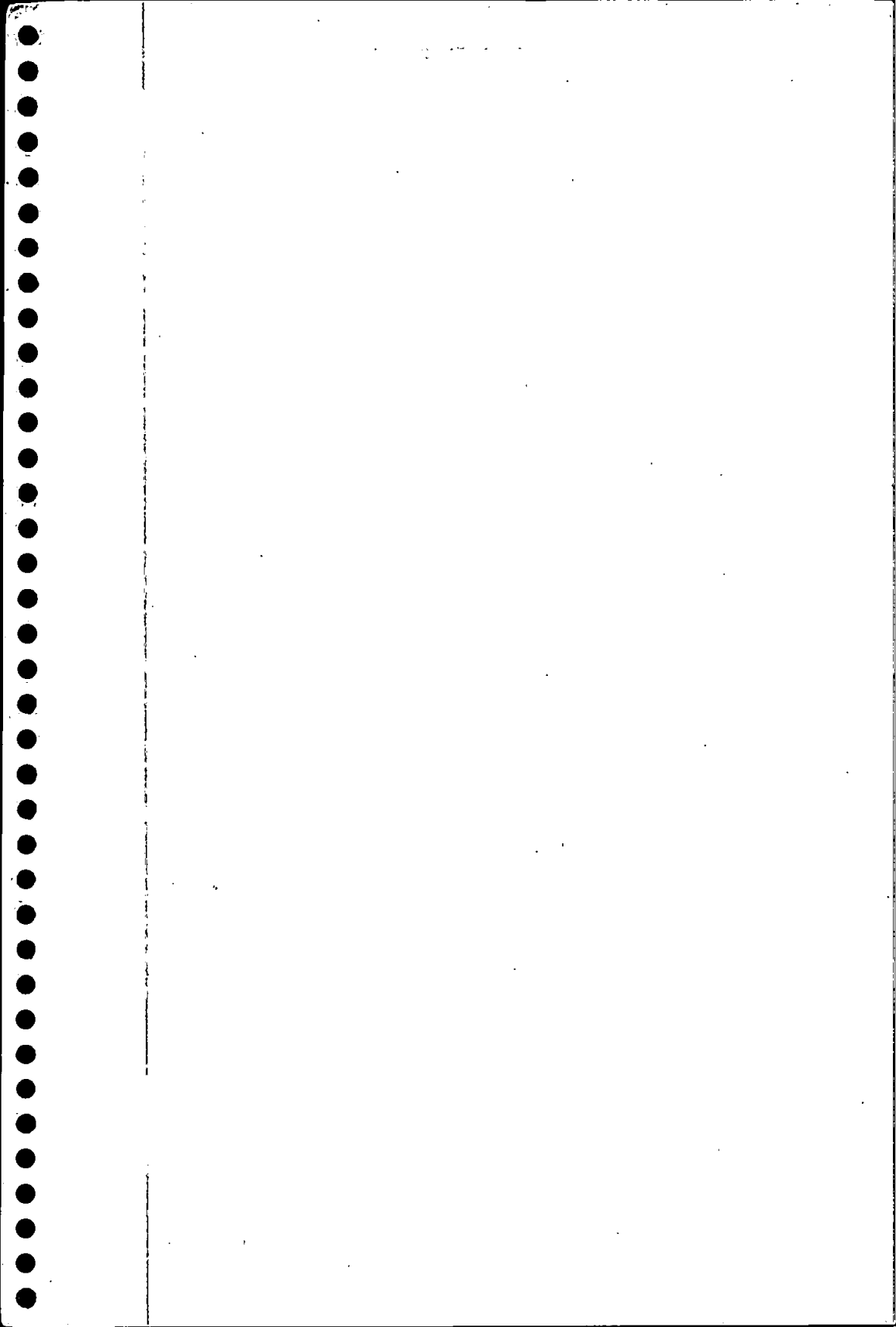

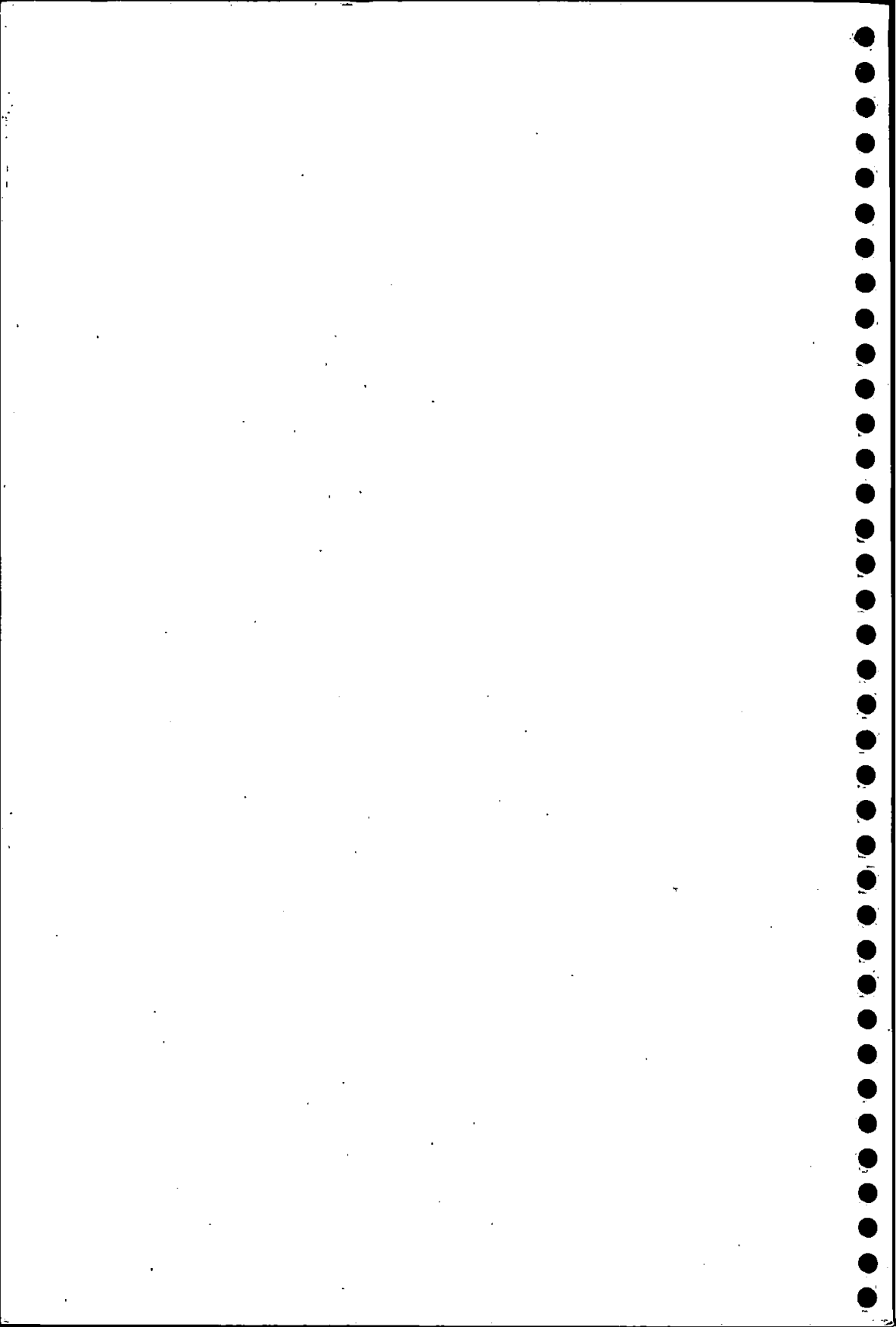

EPSON®  
LX-800



Quick Reference

---

# DIP Switch Settings

Table 1. DIP switch group 1

Switch number	Function	Action when ON	Action when OFF
1-1	Select condensed or normal characters	Condensed	Normal
1-2	Select slashed or unslashed zero	0	0
1-3	Select character table	Graphics	Italics
1-4	Paper-out detection	Inactive	Active
1-5	Select print quality	NLQ	Draft
1-6 1-7 1-8	Select international character set	See Table 3	

Table 2. DIP switch group 2

Switch number	Function	Action when ON	Action when OFF
2-1	Select page length	12 inch	11 inch
2-2	Select cut sheet feeder mode	Selected	Not selected
2-3	Skip-over-perforation	1 inch	None
2-4	Add line feed after carriage return	CR + LF	CR only



Table 3. International settings

Character set	DIP switch settings		
	1-6	1-7	1-8
USA	ON	ON	ON
French	ON	ON	OFF
German	ON	OFF	ON
UK	ON	OFF	OFF
Danish	OFF	ON	ON
Swedish	OFF	ON	OFF
Italian	OFF	OFF	ON
Spanish	OFF	OFF	OFF

## Commands by Function

---

The following list of commands is in the order used in the Command Summary (Appendix A). To find details of the command you want to use, refer to the page number in the right column.

ASCII	Dec	Hex	Description	Page
<b>Printer operation</b>				
ESC @	64	40	Initialize the printer	A-7
DC1	17	11	Select printer	A-7
DC3	19	13	Deselect printer	A-7
ESC s	115	73	Half-speed mode on/off	A-8
ESC <	60	3C	Select unidirectional mode (1-line)	A-8
ESC U	85	55	Turn unidirectional mode on/off	A-8
ESC 8	56	38	Disable paper-out sensor	A-9
ESC 9	57	39	Enable paper-out sensor	A-9
ESC EM	25	19	Cut sheet feeder on/off	A-9
BEL	7	07	Beeper	A-10
<b>Data control</b>				
CR	13	0D	Carriage return	A-10
CAN	24	18	Cancel line	A-10
DEL	127	7F	Delete character	A-11
<b>Vertical/horizontal motion</b>				
FF	12	0C	Form feed	A-11
ESC C	67	43	Set page length in lines	A-11
ESC C0	67	43	Set page length in inches	A-12
ESC N	78	4E	Set skip-over-perforation	A-12
ESC O	79	4F	Cancel skip-over-perforation	A-12
LF	10	0A	Line feed	A-13
ESC 0	48	30	Select 1/8-inch line spacing	A-13
ESC 1	49	31	Select 7/72-inch line spacing	A-13
ESC 2	50	32	Select 1/6-inch line spacing	A-14
ESC 3	51	33	Select n/216-inch line spacing	A-14
ESC A	65	41	Select n/72-inch line spacing	A-14
ESC J	74	4A	Perform n/216-inch line feed	A-15
VT	11	0B	Tab vertically	A-15
ESC B	66	42	Set vertical tabs	A-15

---

ASCII	Dec	Hex	Description	Page
ESC b	98	62	Set vertical tabs in channels	A-16
ESC /	47	2F	Select vertical tab channel	A-16
ESC l	108	6C	Set left margin	A-16
ESC Q	81	51	Set right margin	A-17
BS	8	08	Backspace	A-17
ESC e	101	65	Set tab increments	A-17
ESC f	102	66	Horizontal/vertical skip	A-18
HT	9	09	Tab horizontally	A-18
ESC D	68	44	Set horizontal tabs	A-18

### Overall printing style

ESC x	120	78	Select NLQ or draft	A-19
ESC k	107	6B	Select NLQ font	A-19
ESC !	33	21	Master select	A-20

### Print size

ESC P	80	50	Select pica pitch	A-20
ESC M	77	4D	Select elite pitch	A-21
SI	15	0F	Select condensed mode	A-21
ESC SI	15	0F	Select condensed mode	A-21
DC2	18	12	Cancel condensed mode	A-21
SO	14	0E	Select double-wide (1 line)	A-22
ESC SO	14	0E	Select double-wide (1 line)	A-22
DC4	20	14	Cancel double-wide (1 line)	A-22
ESC W	87	57	Turn double-wide on/off	A-23

### Print enhancement

ESC E	69	45	Select emphasized mode	A-23
ESC F	70	46	Cancel emphasized mode	A-23
ESC G	71	47	Select double-strike mode	A-24

---

ASCII	Dec	Hex	Description	Page
-------	-----	-----	-------------	------

---

ESC H	72	48	Cancel double-strike mode	A-24
ESC S0	83	53	Select superscript mode	A-24
ESC S1	83	53	Select subscript mode	A-25
ESC T	84	54	Cancel superscript/subscript	A-25
ESC -	45	2D	Turn underlining on/off	A-25

### Word processing

ESC a	97	61	NLQ justification	A-26
-------	----	----	-------------------	------

### Character sets

ESC t	116	74	Select character table	A-26
ESC 4	52	34	Select italic mode	A-27
ESC 5	53	35	Cancel italic mode	A-27
ESC R	82	52	Select international character set	A-28
ESC 6	54	36	Printable code expansion	A-28
ESC 7	55	37	Cancel ESC 6	A-28

### User-defined characters

ESC &	38	26	Define user-defined characters	A-29
ESC :	58	3A	Copy ROM into RAM	A-29
ESC %	37	25	Select user-defined set	A-29

### Graphics

ESC K	75	4B	Single-density graphics	A-30
ESC L	76	4C	Double-density graphics	A-30
ESC Y	89	59	High-speed dbl.-density graphics	A-30
ESC Z	90	5A	Quadruple-density graphics	A-31
ESC *	42	2A	Select graphics mode	A-31
ESC ?	63	3F	Reassign graphics mode	A-31
ESC ^	94	5E	Select nine-pin graphics	A-32

---

LX-800

---

**Featuring:**  
Setting Up  
Printer Features  
Graphics  
User-defined Characters

EPSON AMERICA, INC. 2780 Lomita Boulevard, Torrance, California 90505

---

**EPSON®**