

# Service Manual

PCM Keyboard

## SX-KZ250

(M), (MC), (XM), (XS), (XD), (X), (XT)



### AREAS

(M): U.S.A.	(X): the Middle East,
(MC): Canada	Indonesia, Hong Kong,
(XM): Mexico	the Philippines,
(XS): Malaysia, Singapore	Thailand
(XD): Saudi Arabia, Kuwait	(XT): Taiwan

### ⚠ WARNING

This service literature is designed for experienced repair technicians only and is not designed for use by the general public. It does not contain warnings or cautions to advise non-technical individuals of potential dangers in attempting to service a product. Products powered by electricity should be serviced or repaired only by experienced professional technicians. Any attempt to service or repair the product or products dealt with in this service literature by anyone else could result in serious injury or death.

### ■ Specifications

KEYBOARD	61 KEYS ( WITH INITIAL TOUCH )	
SOUND GENERATOR	PCM	
MAXIMUM NUMBER OF NOTES PRODUCED SIMULTANEOUSLY	28 NOTES	
SOUNDS	SOUND SELECT	128 SOUNDS, 1 drum set
	EFFECT	STEREO CHORUS, SUSTAIN
	SOUND EFFECT	○
RHYTHM	RHYTHM SELECT	100 PATTERNS
	CONTROLS	START/STOP, SYNCHRO, INTRO & ENDING, FILL IN, TEMPO
AUTO PLAY CHORD	ONE FINGER, FINGERED, ONE TOUCH PLAY	
DUET	○	
PANEL MEMORY	SET, 1- 2	
SEQUENCER	STORAGE CAPACITY:APPROX. 2800 NOTES INPUT MODES :REALTIME FUNCTIONS:OVER DUB, ERASE	
DISPLAY	LED (3 DIGITS), EXIT	
CONTROLS	MAIN VOLUME, BALANCE, TRANSPOSE, CONDUCTOR	
DEMO	○	
MODE SET	GM MODE SET, TUNING, TOUCH CURVE, SPLIT POINT, FOOT SW SETTING, MIDI BASIC CH, LOCAL CONTROL, ACCOMP MIDI OUT, DRUM SEND MODE, BULK DUMP	
TERMINALS	DC IN 12 V, PHONES/LINE OUT, MIDI (IN,OUT), FOOT SWITCH	
OUTPUT	2 W × 2 (WITH BATTERIES), 3.5 W × 2 (WITH SY-AD6/AD6B/AD7 AC ADAPTOR)	
SPEAKERS	12 cm × 2	

# Panasonic

© 1994 Matsushita Electric Industrial CO., LTD. All rights reserved.  
Unauthorized copying and distribution is a violation of law.

POWER REQUIREMENT	BATTERIES:DC 9 V (USING R20/LR20["D" SIZE, UM-1] BATTERIES × 6)	
	AC:WITH SY-AD6/AD7 AC ADAPTOR	AC 120/220/230/240 V, 50/60 Hz AC 120V 60 Hz (NORTH AMERICA AND MEXICO)
	AC:WITH SY-AD6/AD6B/ AD7 AC ADAPTOR	AC 230 V, 50/60 Hz (NEW ZEALAND AND EUROPE EXCEPT FOR UNITED KINGDOM)
DIMENSIONS (W×H×D)	96.4 cm × 11.2 cm × 36.2 cm (37-15/16" × 4-13/32" × 14-1/4")*	
NET WEIGHT	6.8 kg (15.0 lbs)*	
ACCESSORIES	AC ADAPTOR SY-AD6/AD6B/AD7 (SOME DISTRICTS ONLY), MUSIC STAND	

Specification are subject to change without notice for further improvement.  
\*Without MUSIC STAND.

---

# CONTENTS

---

## ■ PART I (INTRODUCTION)

ARRANGEMENT OF CONTROL PANEL .....	I-2
INITIAL SETTING .....	I-4
CONDUCTOR SETTINGS .....	I-4
TERMINALS .....	I-5
KEYBOARD RANGES .....	I-5
PARTS LOCATION .....	I-6
DISASSEMBLY INSTRUCTIONS .....	I-7
SYMPTOMS WHICH APPEAR TO BE SIGNS OF TROUBLE .....	I-9
MIDI IMPLEMENTATION CHART .....	I-10
PRECAUTIONS BEFORE SERVICING .....	I-12

## ■ PART II (SCHEMATIC DIAGRAM)

WIRING CONNECTION DIAGRAM.....	II-1
BLOCK DIAGRAM .....	II-2
<b>MAIN BATT</b> P.C. Board.....	II-4
<b>MAIN BATT</b> P.C. Diagram.....	II-6
<b>CP</b> CONTROL PANEL P.C. Board .....	II-10
<b>CP</b> CONTROL PANEL P.C. Diagram .....	II-12
<b>MKB</b> MANUAL KEYBOARD CIRCUIT.....	II-14

## ■ PART III (REPLACEMENT PARTS LIST)

REPLACEMENT PARTS LIST (P.C.B. and Wiring Parts) .....	III-1
CABINET PARTS LOCATION .....	III-4
REPLACEMENT PARTS LIST (Cabinet and Chassis parts) .....	III-6
PACKING .....	III-7

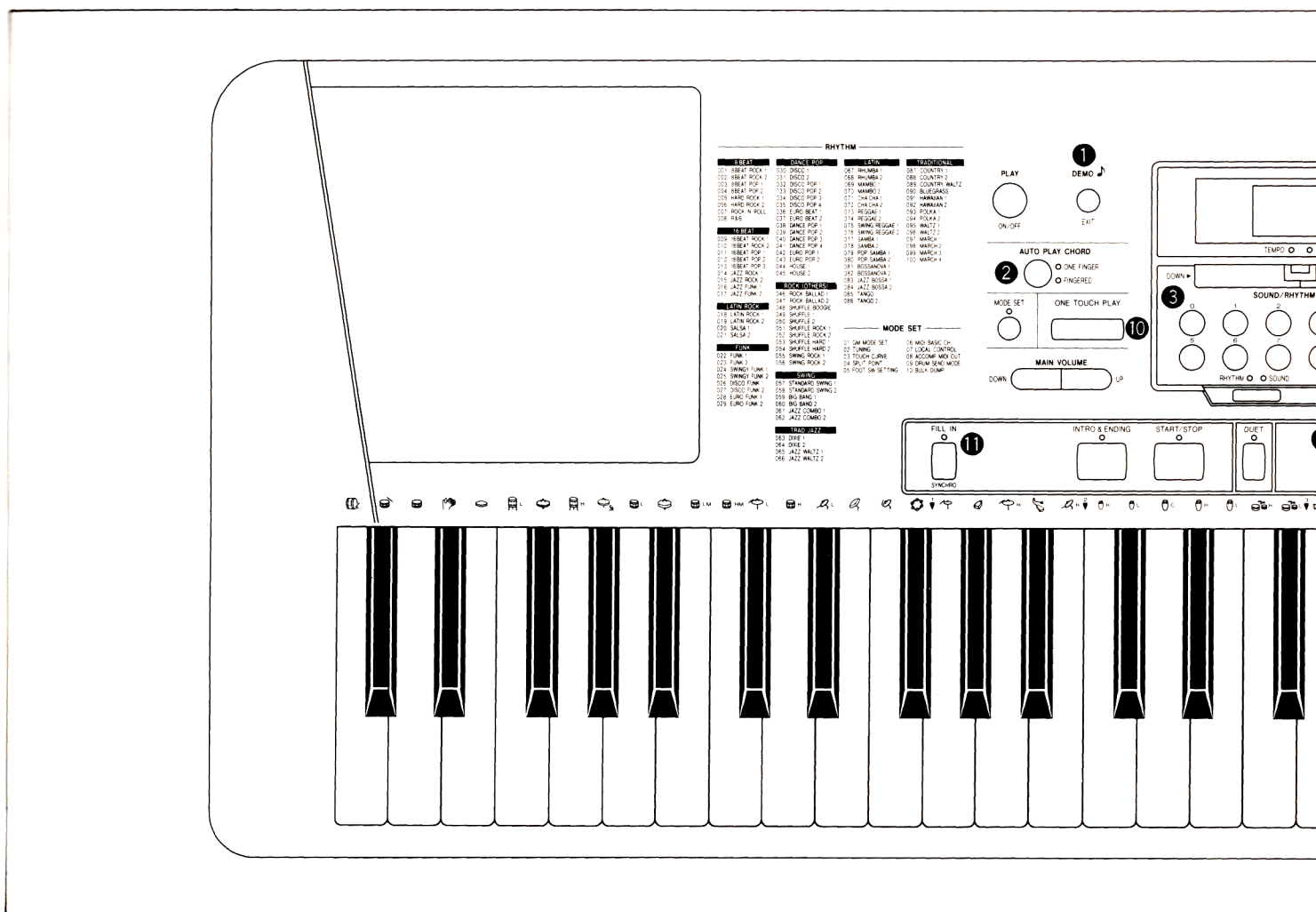

### 1 DEMO

Prerecorded performances are used to demonstrate the individual appear of the rhythms, sounds and other features.

### 2 AUTO PLAY CHORD

An automatic accompaniment appropriate for the selected rhythm is produced when you play a chord. Specify chords with either the **ONE FINGER** or **FINGERED** method.

### 3 SOUND/RHYTHM SELECT

Specify a two-digit number on the number pad to select a sound or rhythm.

### 4 BALANCE

The **BALANCE** buttons are used to select 15 different volume levels for each part—**SOUND 1**, **SOUND 2**, and **RHYTHM**.

### 5 CONDUCTOR

Used to assign the **SOUND 1** and **SOUND 2** parts to the keyboard in various ways. The two parts can even be layered (dual sound) or assigned to different sections of the keyboard (split keyboard).

### 6 DUET

Chord notes played on the left section of the split keyboard are added to melody notes played on the right section.

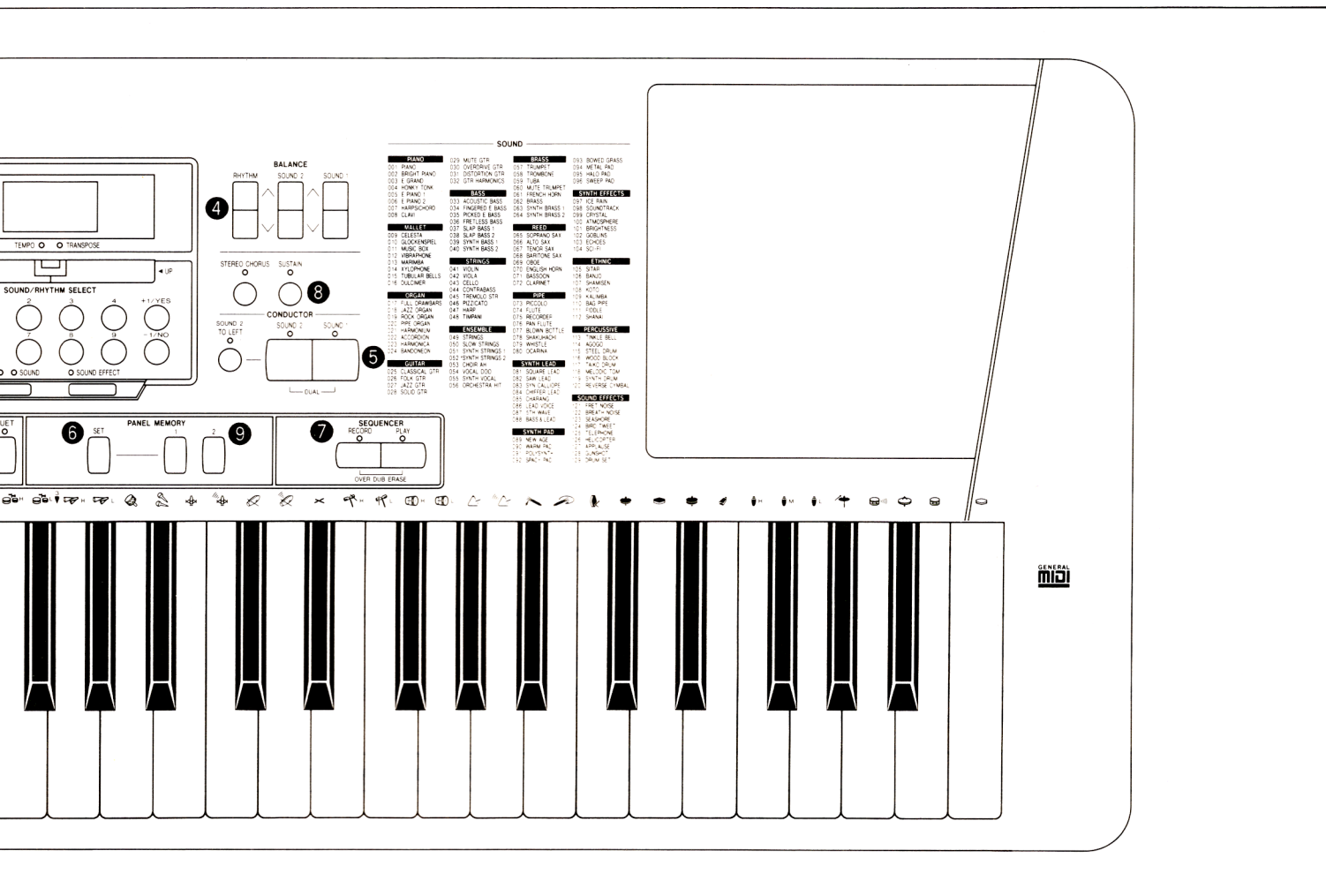

**7 SEQUENCER**

With this feature you can record an entire song, then have the performance played back automatically.

**8 Effects**

**STEREO CHORUS** gives the sound a thickness and diffusion. When **SUSTAIN** is on, the musical tones fade gradually after the keys are released.

**9 PANEL MEMORY**

Set up the sounds and effects, and then store them in these 2 buttons for instant recall as you play.

**10 ONE TOUCH PLAY**

Select a rhythm and press the **ONE TOUCH PLAY** button until the panel settings change. The sounds and effects perfect for the selected rhythm are automatically set in seconds.

**11 Rhythm control**

**START/STOP, SYNCHRO, INTRO & ENDING** and **FILL IN** give you complete control over and add variety and interest to your rhythm performance.

# INITIAL SETTING

■ The initial setting function is used to return to the original factory settings, and to reset the customer settings and misoperations.

1. Press the **PLAY** button to turn off the instrument.
2. While pressing the leftmost C and E keys on the keyboard, turn the **PLAY** button on again.

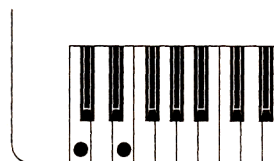

**NOTE:**

All stored data in the **SEQUENCER**, **PANEL MEMORY** and other setting are initialized with this operation.

# CONDUCTOR SETTINGS

■ **Assigning a part to the keyboard**

The **CONDUCTOR** is used to assign the **SOUND 1** and **SOUND 2** sounds to the keyboard in different ways. You can also adjust the volume balance of the two sounds.

CONDUCTOR settings	How sounds are assigned to the keyboard
	<p>All the keys play <b>SOUND 1</b> sounds.</p> <div style="border: 1px solid black; width: 100%; height: 40px; text-align: center; margin-top: 20px;"> <p><b>SOUND 1</b></p> </div>
	<p>All the keys play <b>SOUND 2</b> sounds.</p> <div style="border: 1px solid black; width: 100%; height: 40px; text-align: center; margin-top: 20px;"> <p><b>SOUND 2</b></p> </div>
	<p>All the keys play both <b>SOUND 1</b> and <b>SOUND 2</b> sounds at the same time (dual sound).</p> <div style="border: 1px solid black; width: 100%; height: 40px; text-align: center; margin-top: 20px;"> <p><b>SOUND 1 + SOUND 2</b></p> </div>
	<p>The right keys play <b>SOUND 1</b> sounds and the left keys play <b>SOUND 2</b> sounds (split keyboard).</p> <div style="border: 1px solid black; width: 100%; height: 40px; display: flex; justify-content: space-between; margin-top: 20px;"> <div style="width: 45%; text-align: center;"><p><b>SOUND 2</b></p></div> <div style="width: 45%; text-align: center;"><p><b>SOUND 1</b></p></div> </div>

# TERMINALS

(On the rear panel)

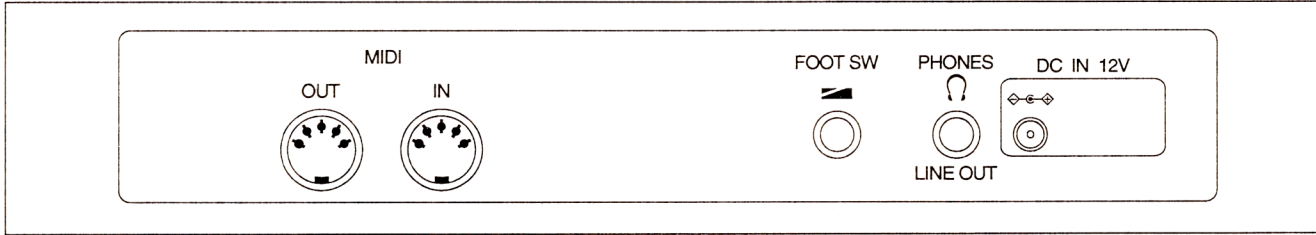

## MIDI (Musical Instrument Digital Interface)

MIDI is the standard specification that enables connection to equipment such as synthesizers and personal computers. Data transmission and reception are possible between the keyboard and other instruments provided with MIDI terminals.

**IN :** The terminal that receives data from external equipment.

**OUT :** The terminal that transmits data from this instrument to external equipment.

- Use a 5-pin DIN cord (less than 15 m long) for these connections.

## FOOT SW

The optional SZ-P1 Foot Switch (sold separately) can be connected to this terminal to control various functions.

**PHONES** (  : Use headphones with over 16 Ω impedance)/  
**LINE OUT** (output level 1.5 Vrms, 16 Ω)

Headphones, a keyboard amplifier, or stereo equipment can be connected to this terminal. When another apparatus is connected to this terminal, the speaker system is automatically switched off, and sound is heard only through the connected device.

## DC IN (12 V)

Standard household current can be used by connecting the Technics SY-AD6(B) /AD7 AC adaptor between a wall outlet and the DC IN 12 V terminal on the instrument.

- Use of a different AC adaptor may damage this instrument.

# KEYBOARD RANGES

This keyboard features Touch Response, by which you control the volume by playing the keys harder or softer.

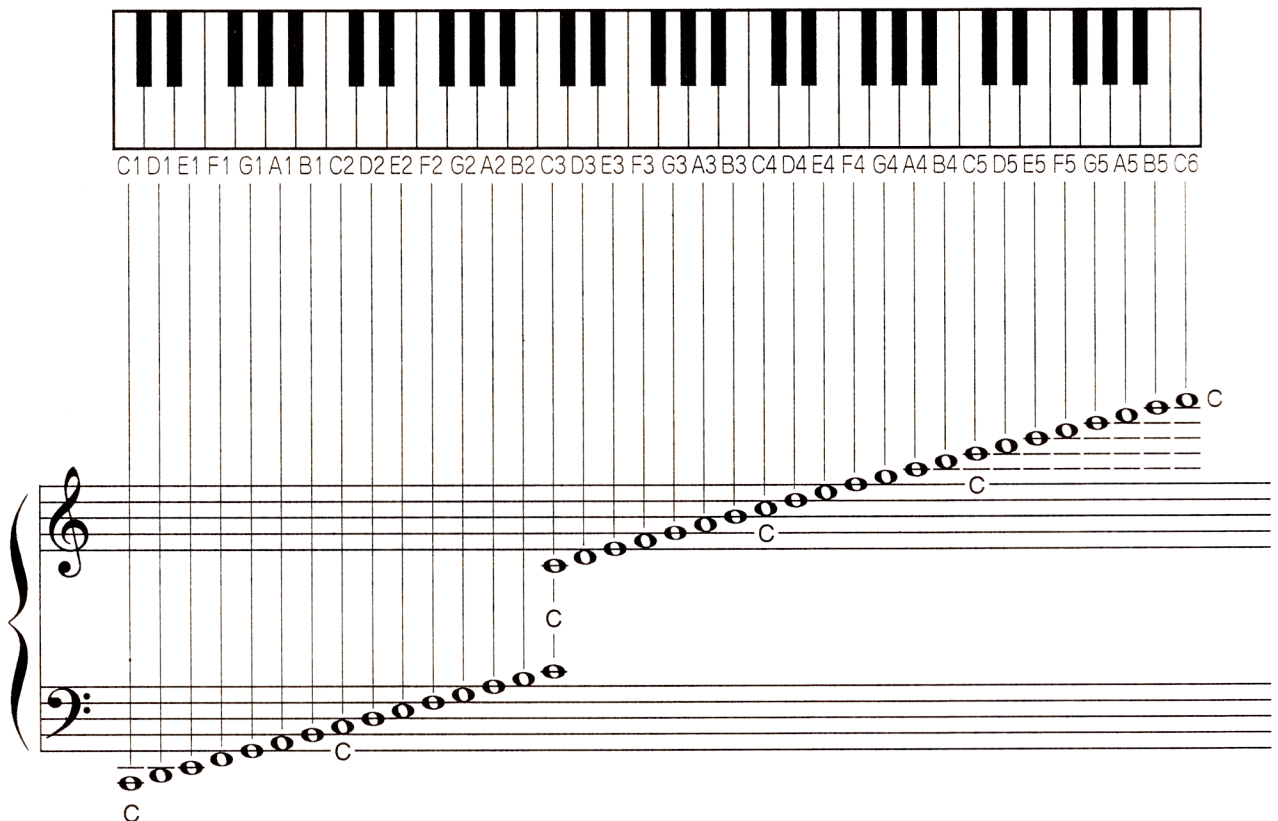

# PARTS LOCATION

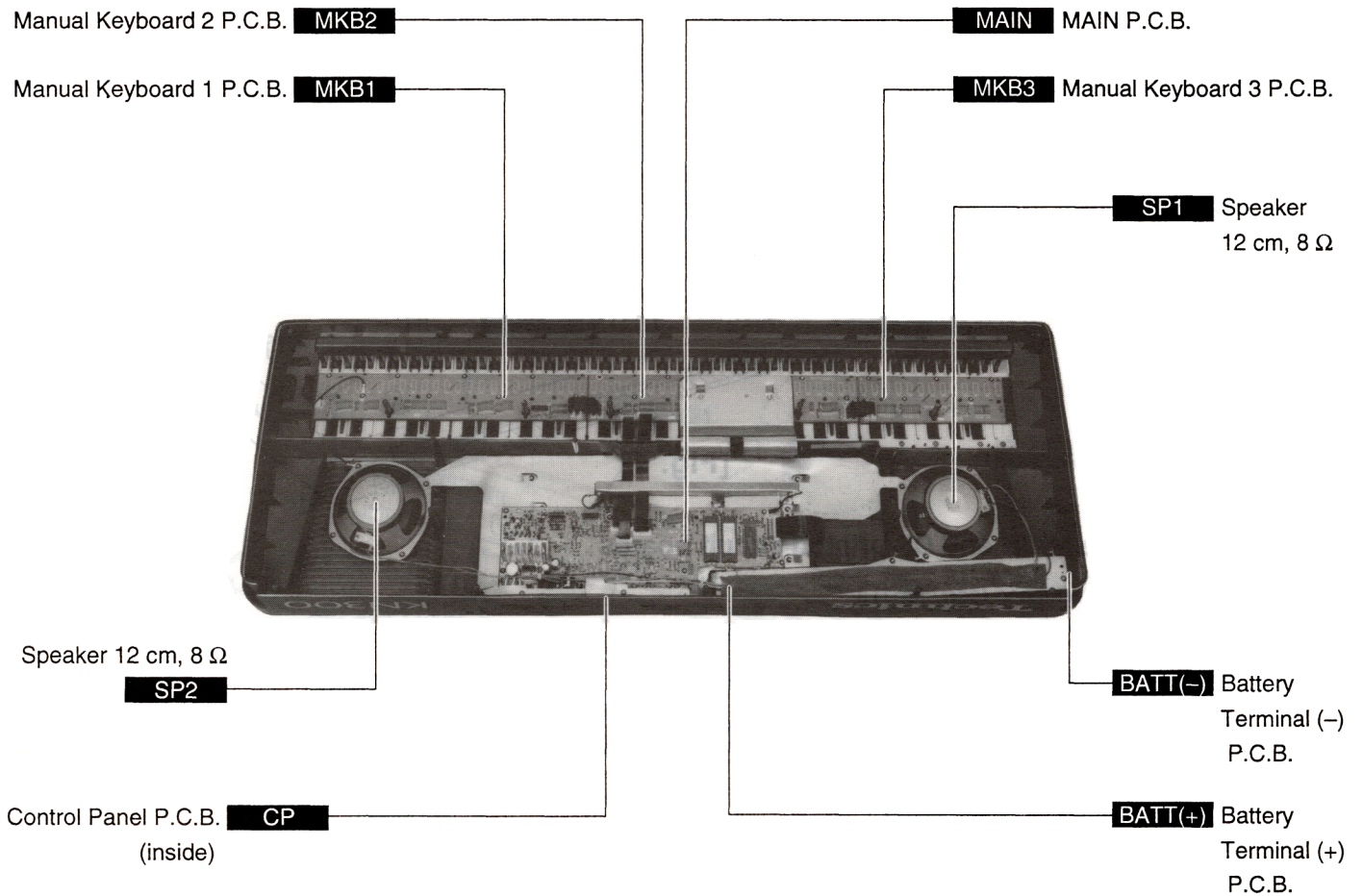

[Photo-1]

# DISASSEMBLY INSTRUCTION

## 1 Removing the bottom case

1. Turn the keyboard cabinet upside down as shown in Fig. 1.
2. Remove the screws (A) 28 pcs.).

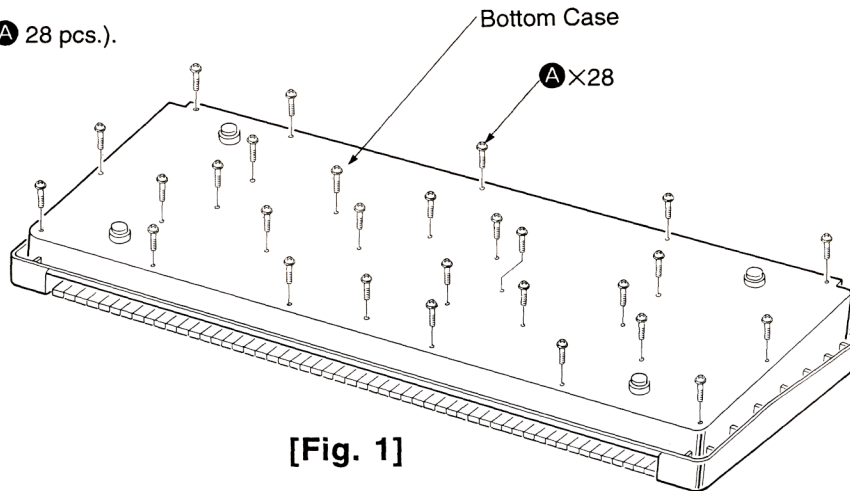

## 2 Removing the MAIN and CP printed circuit boards

- Remove the bottom case (see step 1).

### MAIN P.C.B.

1. Remove the MAIN P.C.B. mounting screws (B) 8 pcs. and (C) 3 pcs.).

### CP P.C.B.

1. Remove the MAIN P.C.B..
2. Remove the bracket holding screws (D) 3 pcs.).
3. Remove the shield cover holding screws (E) 9 pcs.).
4. Remove the CP P.C.B. mounting screws (F) 6 pcs.).

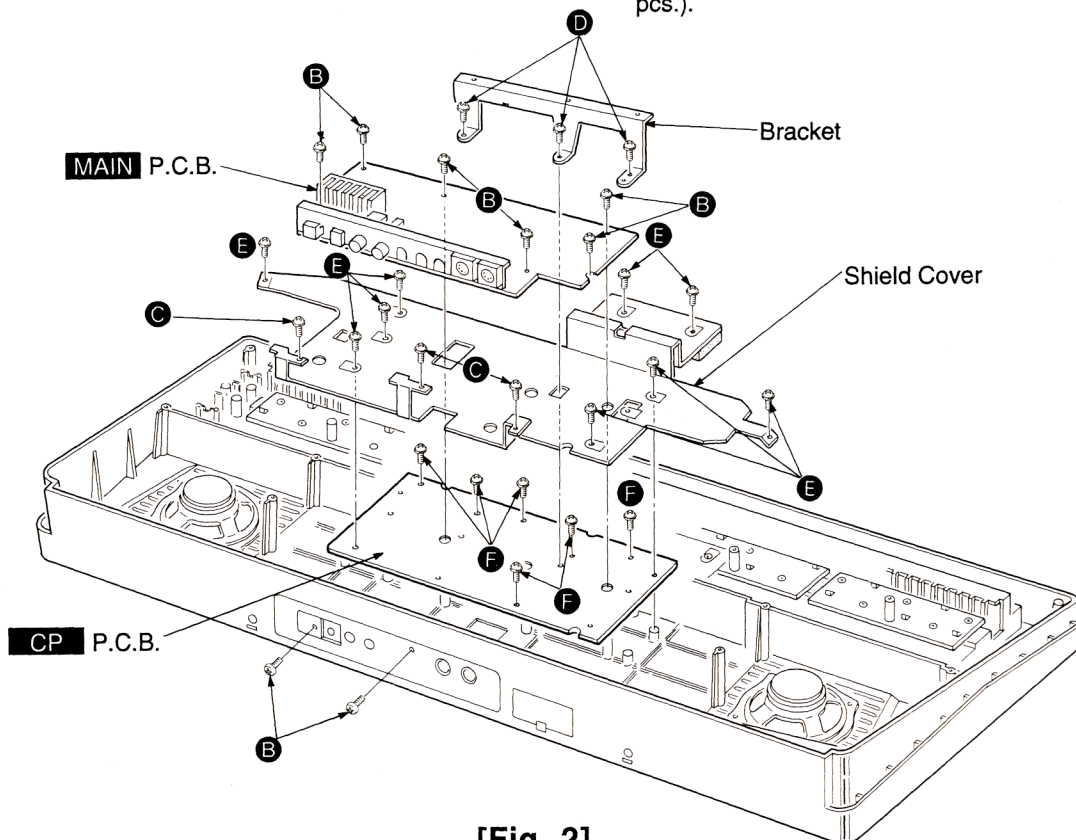

### 3 Removing the MKB 1, 2, 3, BATT(+) and BATT(-) printed circuit boards

· Remove the bottom case (see step 1).

#### MKB1, 2, 3 P.C.B.

1. Remove the MKB 1, 2, 3 P.C.B. mounting screws (G 21 pcs.).

#### BATT(+), BATT(-) P.C.B.

1. Remove the battery cover mounting screws (H 4 pcs.).
2. Pull out the BATT (+) P.C.B. and BATT (-) P.C.B. from the cabinet.

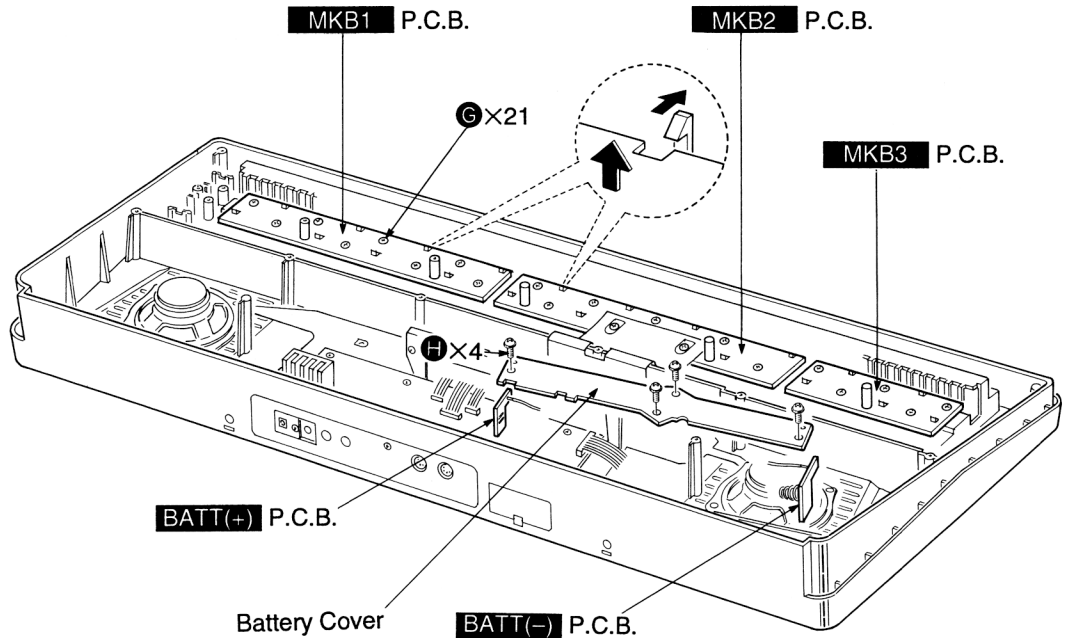

[Fig. 3]

# SYMPTOMS WHICH APPEAR TO BE SIGNS OF TROUBLE

The following changes in performance may occur in Keyboard but do not indicate trouble.

	Phenomenon	Remedy
Sounds and effects	The buttons, keys, etc. malfunction.	<ul style="list-style-type: none"> <li>• Turn off the <b>PLAY</b> button once, then turn it on again. If this procedure is not successful, turn off the <b>PLAY</b> button once. Then, while pressing the leftmost C and E keys on the keyboard, turn the <b>PLAY</b> button on again. (Note that, in this case, all programmable settings, functions and memories return to their factory-preset status.)</li> <li>• If you cannot turn off the <b>PLAY</b> button, disconnect the AC adaptor or remove the batteries once.</li> </ul>
	No sound is produced when the keys are pressed.	<ul style="list-style-type: none"> <li>• The <b>MAIN VOLUME</b> is at the minimum setting. Adjust the volume with the <b>MAIN VOLUME</b> buttons.</li> <li>• The local control is set to [oFF]. Set the local control to [on].</li> </ul>
	You hear sound effects when you attempt to select a different sound or rhythm on the number pad.	<ul style="list-style-type: none"> <li>• The <b>SOUND EFFECT</b> button is on. Press it to turn it off.</li> </ul>
	When using batteries, the volume level become low, the sound is distorted, or the buttons and keys do not function.	<ul style="list-style-type: none"> <li>• The batteries are low. Replace the batteries as soon as possible.</li> </ul>
	Only percussive instrument sounds are produced when the keyboard is played.	<ul style="list-style-type: none"> <li>• A <b>DRUM SET</b> sound (number <b>129</b>) has been selected. On the <b>SOUND/RHYTHM SELECT</b> number pad, select a different sound number.</li> </ul>
Rhythm	No sound is produced for the rhythm.	<ul style="list-style-type: none"> <li>• On the <b>SOUND/RHYTHM SELECT</b> number pad, <b>COMPOSER (099 or 100)</b> was selected although a rhythm pattern has not been stored. Select a different rhythm or store a rhythm pattern in the <b>COMPOSER</b></li> </ul>
	The rhythm does not start.	<ul style="list-style-type: none"> <li>• The tempo has been set to a number lower than 048, and the mode has changed to the external <b>CLOCK</b> mode. Set the tempo to 048 or higher.</li> <li>• The <b>GM MODE SET</b> setting has been set to GM. Set the mode to Standard.</li> </ul>
SEQUENCER/ COMPOSER	Storage is not possible.	<ul style="list-style-type: none"> <li>• The remaining memory capacity is 0.</li> <li>• When recording in the <b>SEQUENCER</b> by overdubbing, you can repeat the recording procedure a maximum of 5 times. If you wish to continue recording, a portion of the recorded contents must first be erased.</li> </ul>
Other	Noise from this instrument can be heard in a nearby radio or TV set.	<ul style="list-style-type: none"> <li>• This sometimes occurs when electrical equipment such as a radio or TV is used near the instrument. Try moving such electrical equipment further away from the instrument.</li> </ul>
	Radio or TV noise can be heard in this instrument.	<ul style="list-style-type: none"> <li>• The sound may be coming from a nearby broadcast station or amateur radio station. If the sound is bothersome, consult your dealer or service center.</li> </ul>
	The cabinet becomes warm during use.	<ul style="list-style-type: none"> <li>• This instrument has a built-in amplifier section that heats the cabinet to some degree. This is not an indication of trouble.</li> </ul>

# MIDI IMPLEMENTATION CHART

Keyboard [SX-KZ250]

(Technics mode)

Function		Transmitted	Recognized	Remarks
<b>Basic Channel</b>	Default Changed	1 1-16	1-16	
<b>Mode</b>	Default Messages Altered	× × *****	Mode 3 × *****	
<b>Note Number</b>	True voice	○ *****	0-127 0-127	
<b>Velocity</b>	Note ON Note OFF	○ 9n00	○ ×	
<b>After Touch</b>	Key's Ch's	× ×	× ○	
<b>Pitch Bender</b>		○	○*	*Except Channel 10-14
<b>Control Change</b>	1 6 7 10 11 64 91 93 100,101 120 121	× × ○ × × ○ × × × × ×	○ ○ ○ ○ ○ ○ × × ○ ○ ○	Modulation *3) Data entry Volume Panpot *3) Expression Hold *3) Chorus Effect Depth RPN LSB, MSB *4) *3) All sound off Reset all controllers
<b>Prog Change</b>	True #	○ *****	○ 0-127	Except 10-14ch
<b>System exclusive</b>		○	○	
<b>System common</b>	Song Pos Song Sel Tune	***** ***** *****	***** ***** *****	
<b>System Real Time</b>	Clock Commands	○ *1) Start,Stop	○ *2) Start,Stop *5)	
<b>Aux Messages</b>	Local ON/ OFF All notes OFF Active Sense Reset	***** ***** ○ *****	***** ○ ○ *****	
<b>Notes</b>	1) When the RHYTHM is running 2) When it is SYNC.RECORDING through MIDI. 3) Except 10-14ch. 4) RPN #0=Pitch Bender Sensitivity 5) Sync mode are push START Switch			

Mode 1: OMNI ON, POLY

Mode 2: OMNI ON, MONO

○:Yes

Mode 3: OMNI OFF, POLY

Mode 4: OMNI OFF, MONO

×:No

**Keyboard [SX-KZ250]**

**(General MIDI mode)**

Function		Transmitted	Recognized	Remarks
<b>Basic Channel</b>	Default Changed	1 1-16	1-16	
<b>Mode</b>	Default Messages Altered	× × *****	Mode 3 × *****	
<b>Note Number</b>	True voice	○ *****	0-127 0-127	
<b>Velocity</b>	Note ON Note OFF	0-127 9n00	○ ×	
<b>After Touch</b>	Key's Ch's	× ×	× ○	
<b>Pitch Bender</b>		○ (KZ450) × (KZ250)	○*	Except Channel 10
<b>Control Change</b>	1 6 7 10 11 64 91 93 100,101 120 121	× × ○ × × × × × × × ×	○ ○ ○ ○ ○ ○ × × ○ ○ ○	Modulation *1) Data entry Volume Panpot *1) Expression Hold *1) Chorus Effect Depth RPN LSB, MSB *1) *2) All sound off Reset all controllers
<b>Prog Change</b>	True #	○ *****	○ 0-127	Except 10
<b>System exclusive</b>		○	○	
<b>System common</b>	Song Pos Song Sel Tune	***** ***** *****	***** ***** *****	
<b>System Real Time</b>	Clock Commands	***** *****	***** *****	
<b>Aux Messages</b>	Local ON/ OFF All notes OFF Active Sense Reset	***** ***** ○ *****	***** ○ ○ *****	
<b>Notes</b>	1) Except 10ch.      2) RPN - #0=Pitch Bender Sensitivity #1=Master Fine Tuning #2=Master Coarse Tuning. Values are given by Data Entry			

Mode 1: OMNI ON, POLY  
Mode 3: OMNI OFF, POLY

Mode 2: OMNI ON, MONO  
Mode 4: OMNI OFF, MONO

○:Yes  
×:No

# PRECAUTION BEFORE SERVICING

## ■ Precautions for measuring of the output waveforms.

1. The waveform was measured with a "National Digital Storage Oscilloscope VP-5730A". Therefore the waveforms of musical tone signals shown may differ somewhat due to the difference in the timing of triggering.
2. Since the 1/10 test probe is used, the indicated voltage value on the bottom part of each waveform photo is 1/10 of the actual value (e.g. 0.2 V/cm should be 2.0 V/cm).

## ■ Important safety notice:

Components identified by a  mark have special characteristics important for safety. When replacing any of these components, use only manufacturer's specified parts.







## ■ Symbolic Marks

The symbolic marks for resistors and capacitors which used in this circuits are classified as following TABLE-1 and TABLE-2.

### 1. RESISTORS

- Resistors without symbolic mark are FIXED CARBON FILM RESISTORS (ERD-type).
- All resistors are 1/4 WATT,  $\pm 5\%$  TOLERANCE unless otherwise designated in schematic diagrams.





(TABLE-1)

SYMBOL	SPECIFICATION	SYMBOL	SPECIFICATION
	Fixed Carbon Film Resistors "FLAME-PROOF" (ERD—F—type)		Fixed Metal Film Resistors "FLAME-PROOF" (ERX—type)
	Fixed Wire Wound Resistors "FLAME-PROOF" (ERD—F—type)		Fuse Type Fixed Metal Oxide Film Resistors "FLAME-PROOF" (ERQ—type)
	Fixed Metal Oxide Film Resistors "FLAME-PROOF" (ERG—type)		Fuse Type Fixed Carbon Film Resistors "FLAME-PROOF" (ERD2FC—type)
	Fixed Metal Film Resistors (Precaution and High Stability) (ERO—type)		

### 2. CAPACITORS

- Capacitors without symbolic mark are POLYESTER CAPACITORS. (ECQM-type, ECQG-type,  $\pm 10\%$  Tolerance)
- Polarized capacitors without symbolic mark are Aluminum Electrolytic Capacitors. (ECEA-type,  $\pm 20\%$  Tolerance)

(TABLE-2)

SYMBOL	SPECIFICATION	TYPE
	Non-Polarized Electrolytic Capacitors	ECEA_KN_type
	Non-Polarized Electrolytic (for Network System)	ECEA_Y_type
	Tantalum Solid Electrolytic Capacitors	ECS_type
	Metalized Plastic Film Capacitors (TF Series)	ECQV_type
	Temperature Compensating Ceramic Capacitors	ECC_type
	High-Dielectric Constant Ceramic Capacitors	ECK_type ECR_type
	Axial Lead Ceramic Capacitors	ECB_type
	Metalized Polyester Film Capacitors for Across the Line	ECQ_EW_type
	Aluminum Electrolytic Capacitors for Smoothing Circuit	ECES_type
	Multilayer Ceramic Chip Capacitors	ECUV_type

# WIRING CONNECTION Diagram

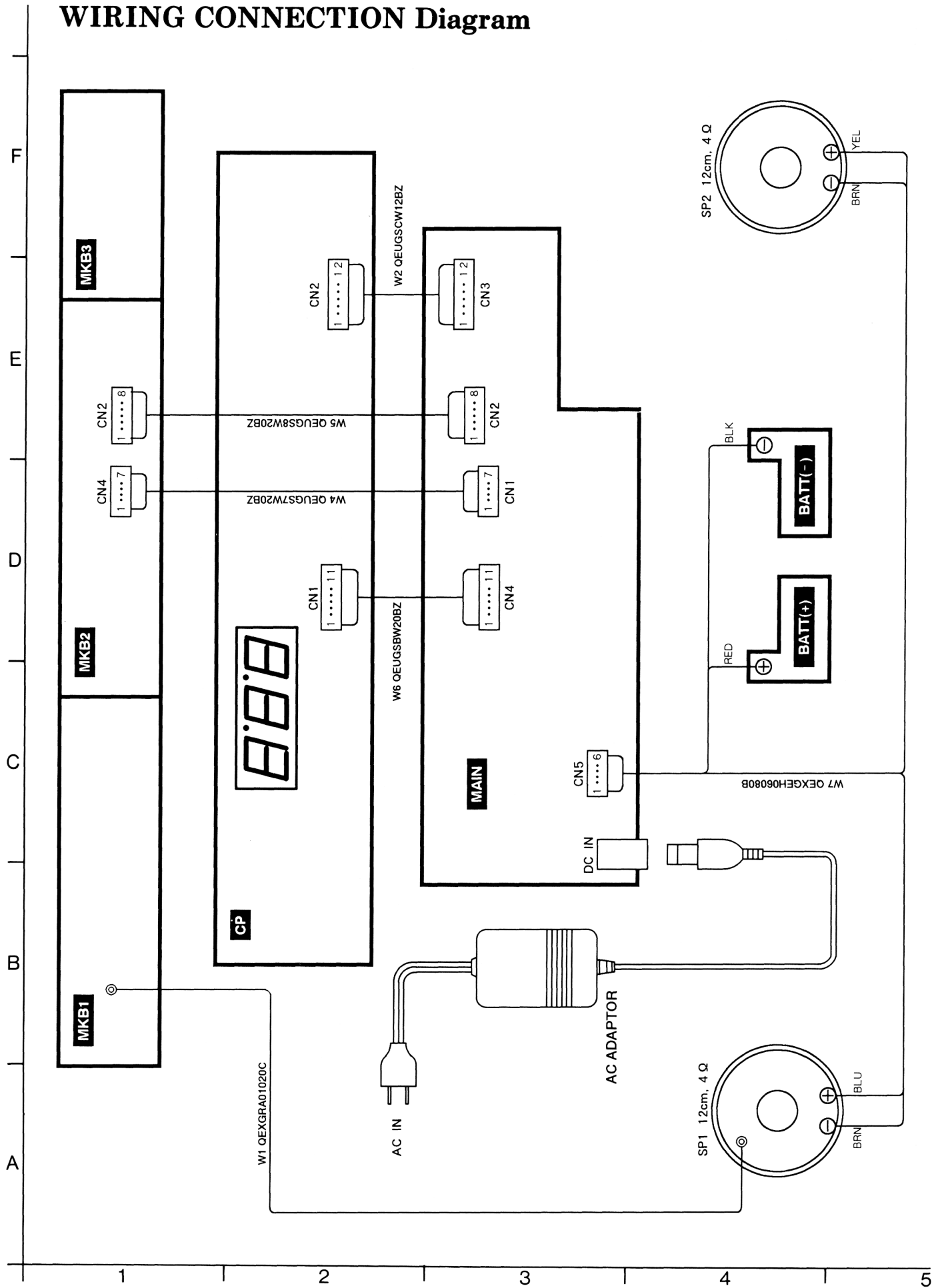

# BLOCK Diagram

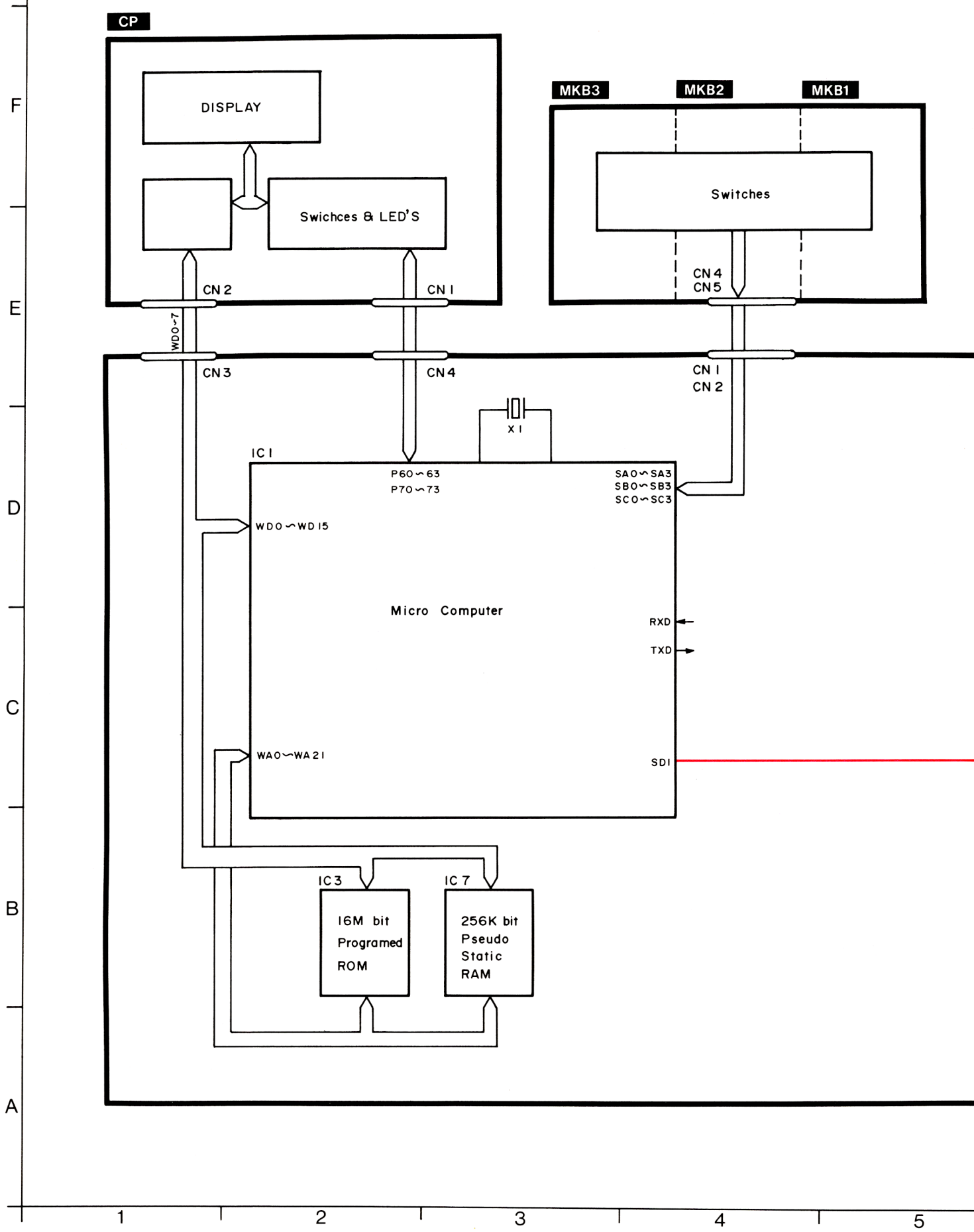

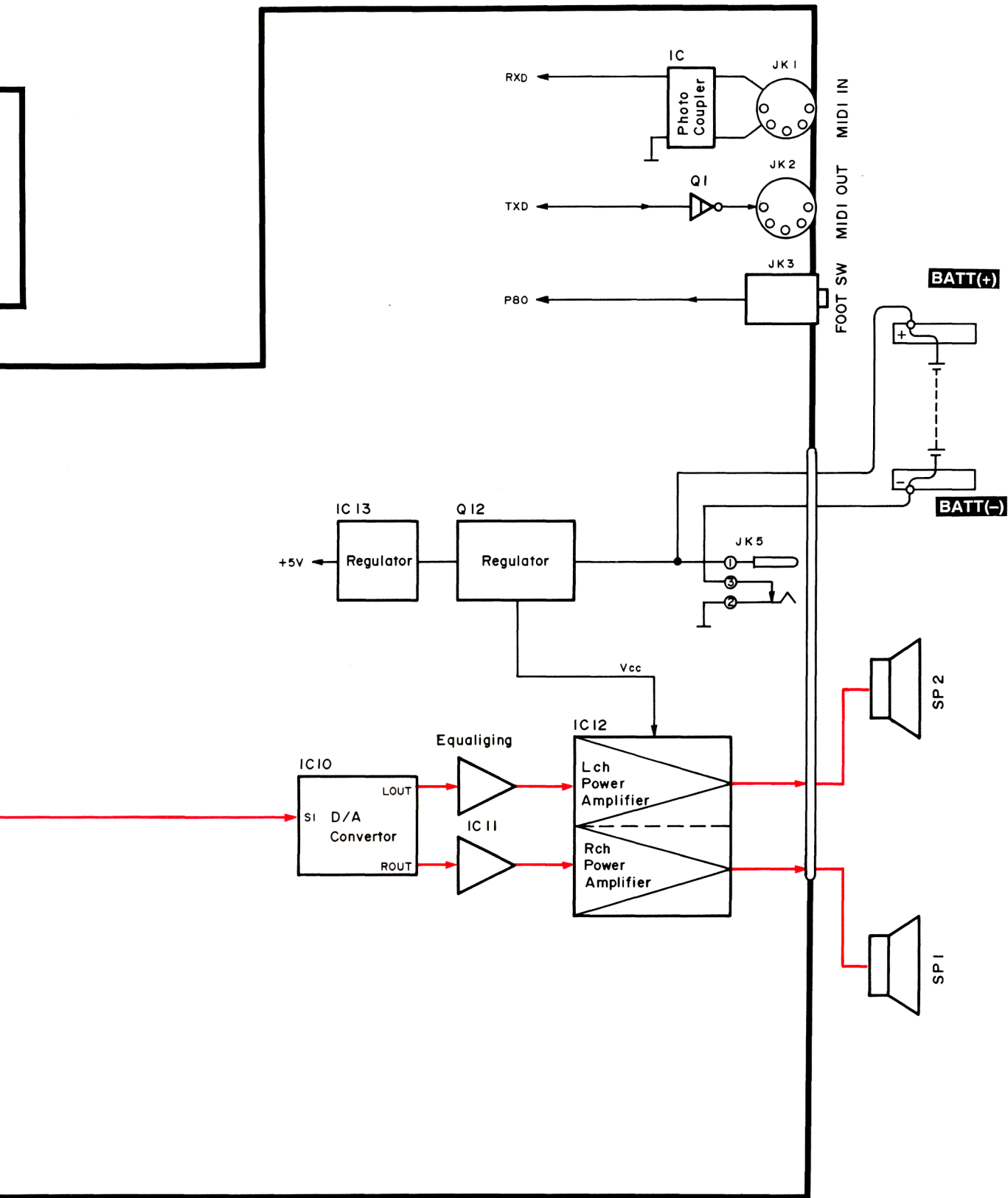

**X** **XD** **XS** **XT** (SXPG219221A)  
**M** **MC** **XM** (SXPG219241A)

MAIN

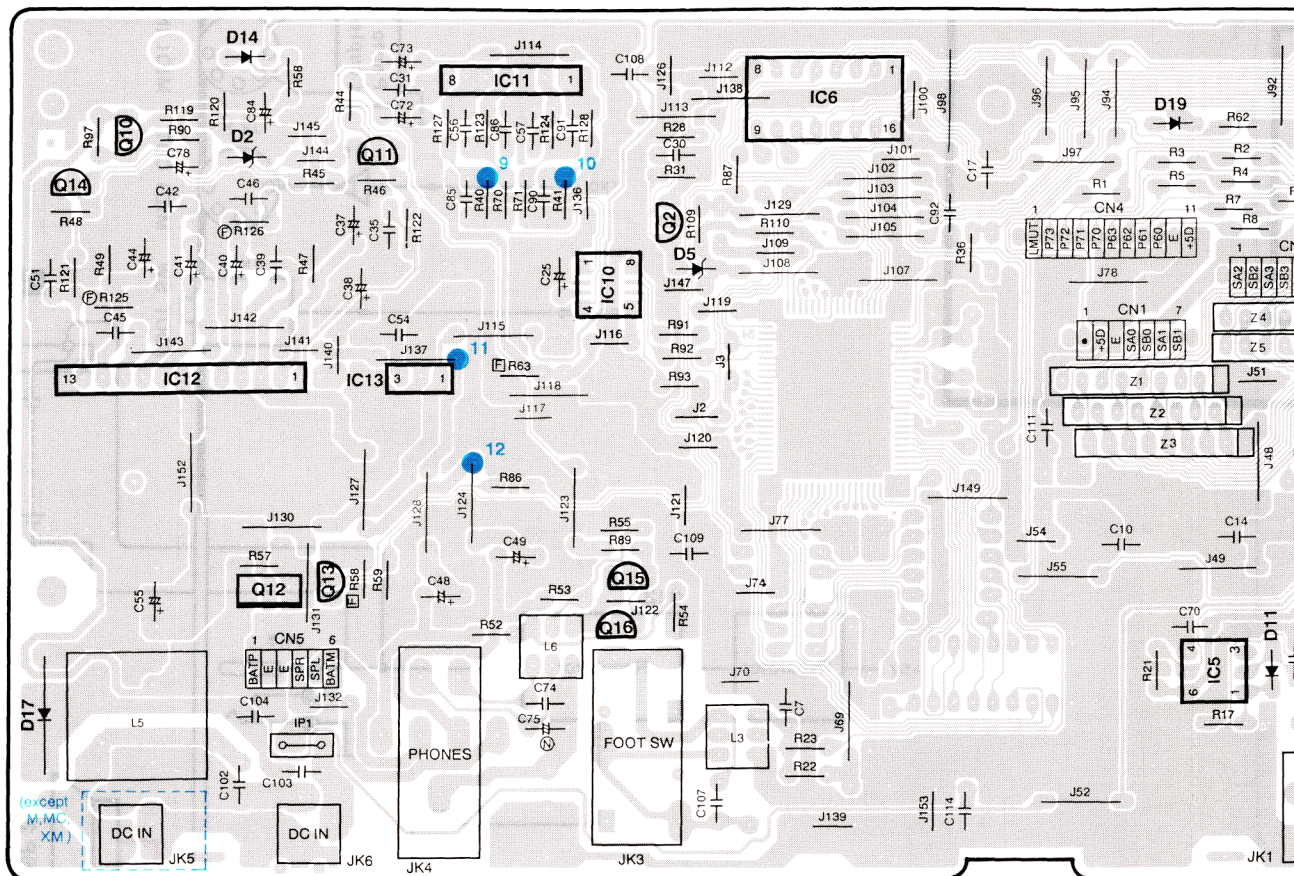

BATT+, - (SXPG220111B)

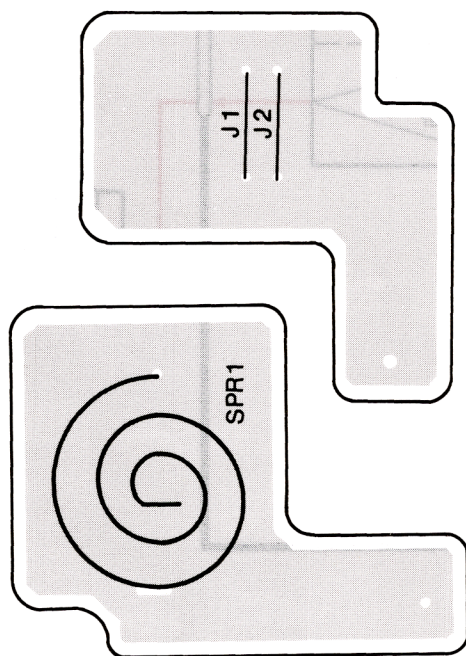

F

E

D

C

B

A

1

2

3

4

5

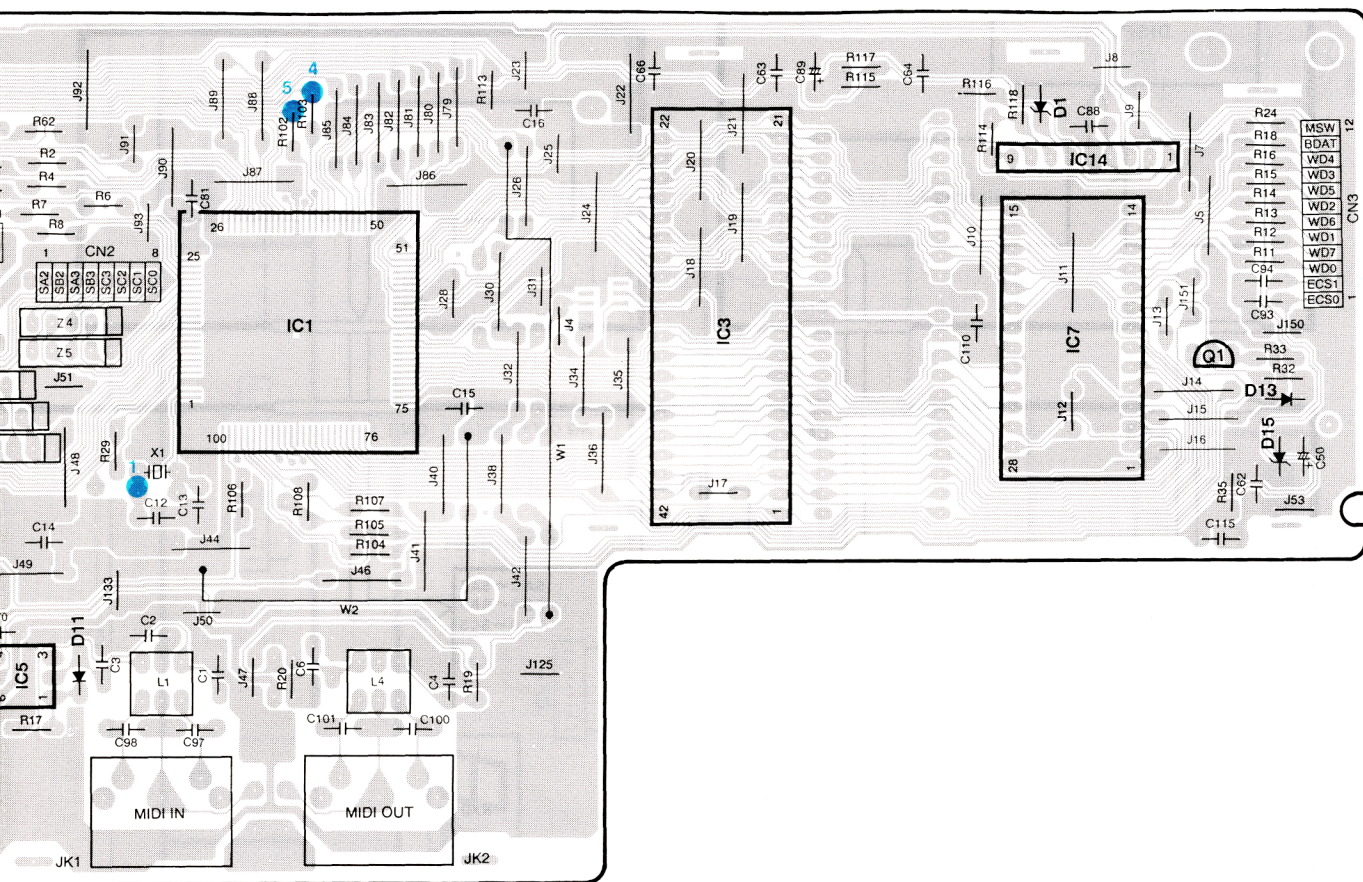

**MAIN**

**NOTES:**

- IC'S
  - IC3: QSIG03C160E5
  - IC5: SVIGTLP513
  - IC6: HD74HC174P
  - IC7: M5256BP70LL
  - IC10: D6379GR-E1
  - IC11: SVIGM5218L
  - IC12: LA4508
  - IC13: UPC24M05HF
  - IC14: AN6913
- TRANSISTORS
  - Q1, 2, 11, 14~16: 2SC1815GR
  - Q10: 2SA1015-GR
  - Q12: 2SA1643
  - Q13: 2SC3940ARS
- DIODES
  - D1: MA4036H
  - D2: MA4022
  - D5, 15: MA4051
  - D11, 13, 14, 19: MA165
  - D17: RK34LF

**Measuring Condition** ■ 波形の測定条件

Check Point ③~⑤

Set to the self-diagnostic mode followings.

- While pressing two E keys (①) simultaneously, turn on the power switch.
- SOUND ..... No. 074 FLUTE
- Main Volume ..... Center
- Keyboard ..... A<sub>1</sub> (②)

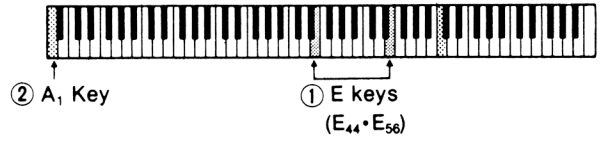

Check Point ①

Set the initial setting mode (Refer to Page I-6)

- SOUND ..... No. 074 FLUTE
- Main Volume ..... Center

①

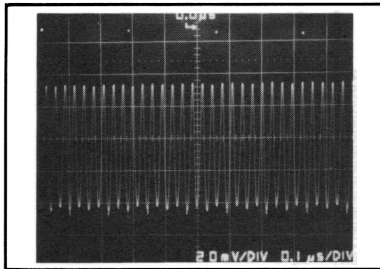

④

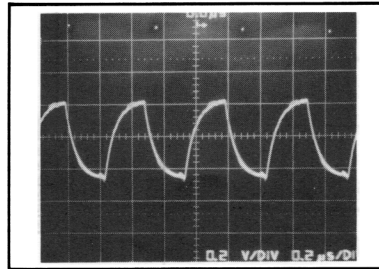

⑤

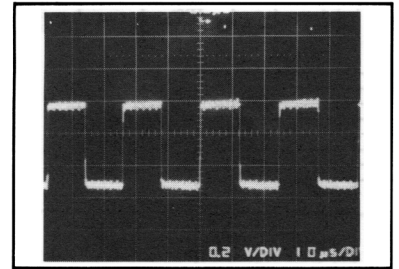

⑨, ⑩

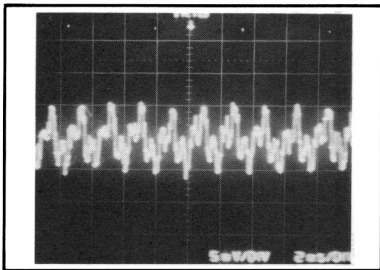

⑪, ⑫

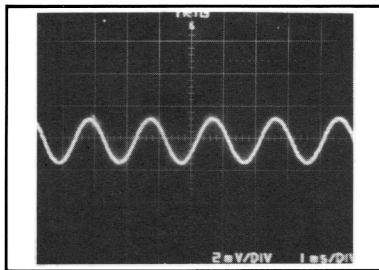

# MAIN/BATT P.C. Diagram

F

E

D

C

B

A

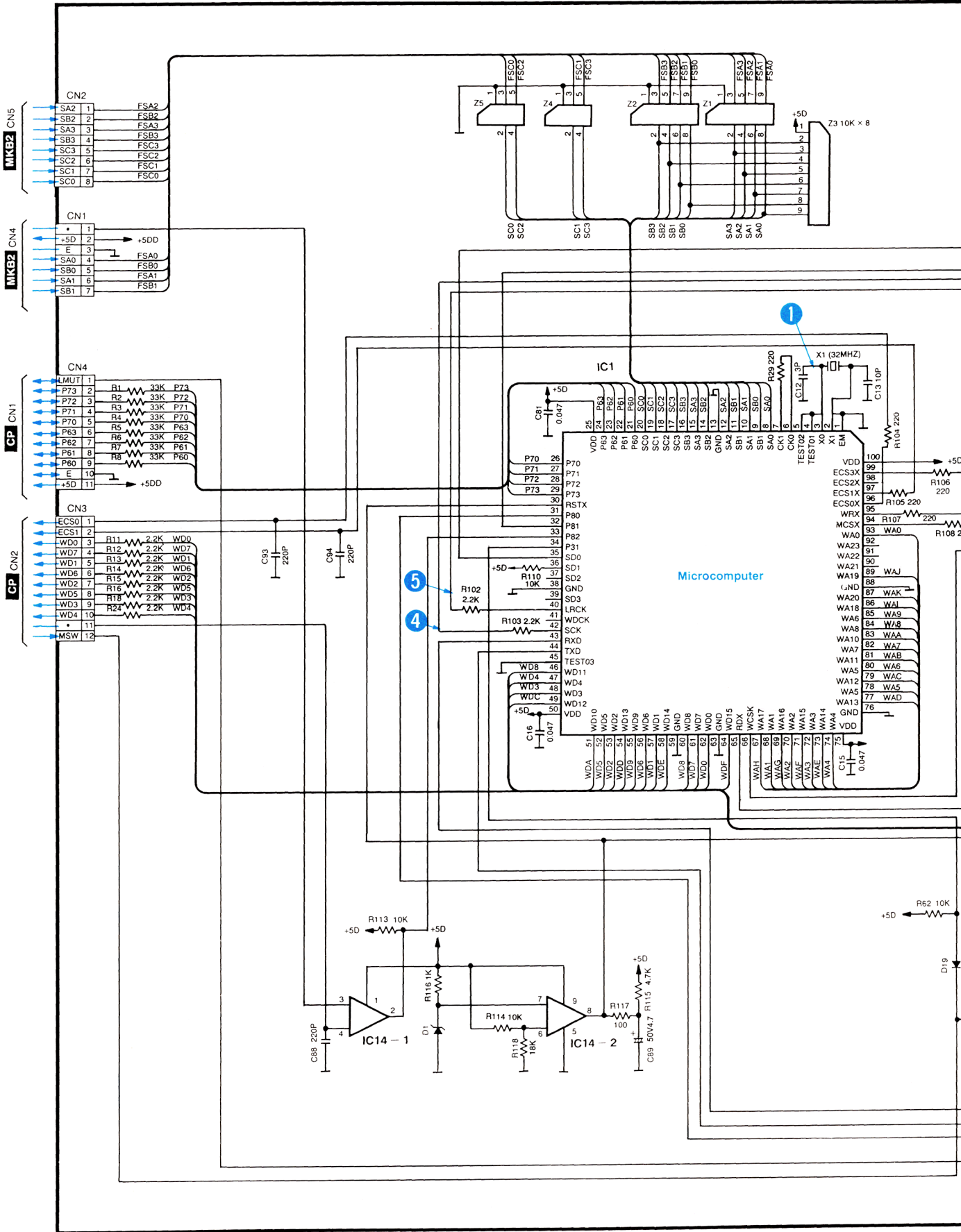

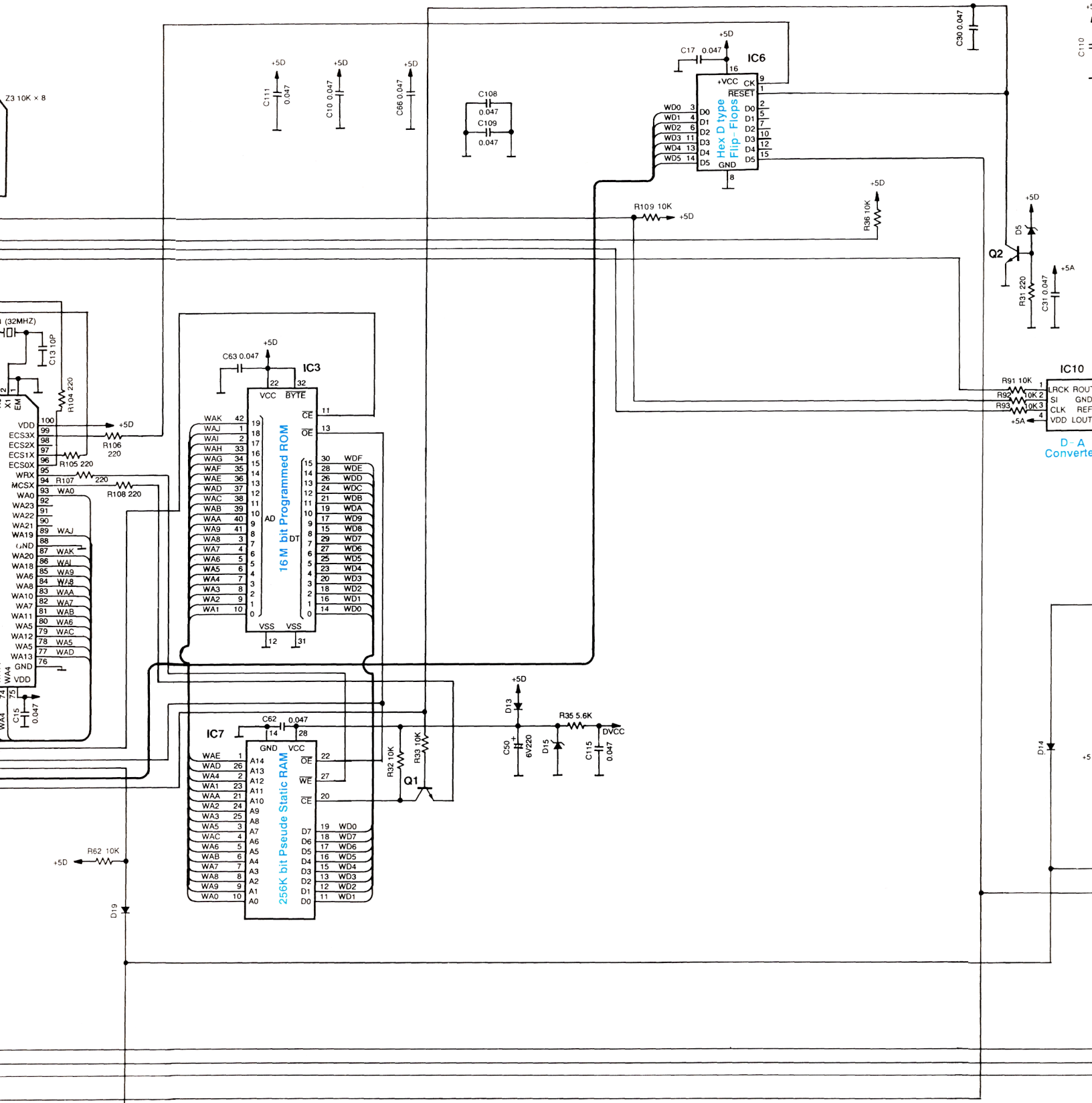

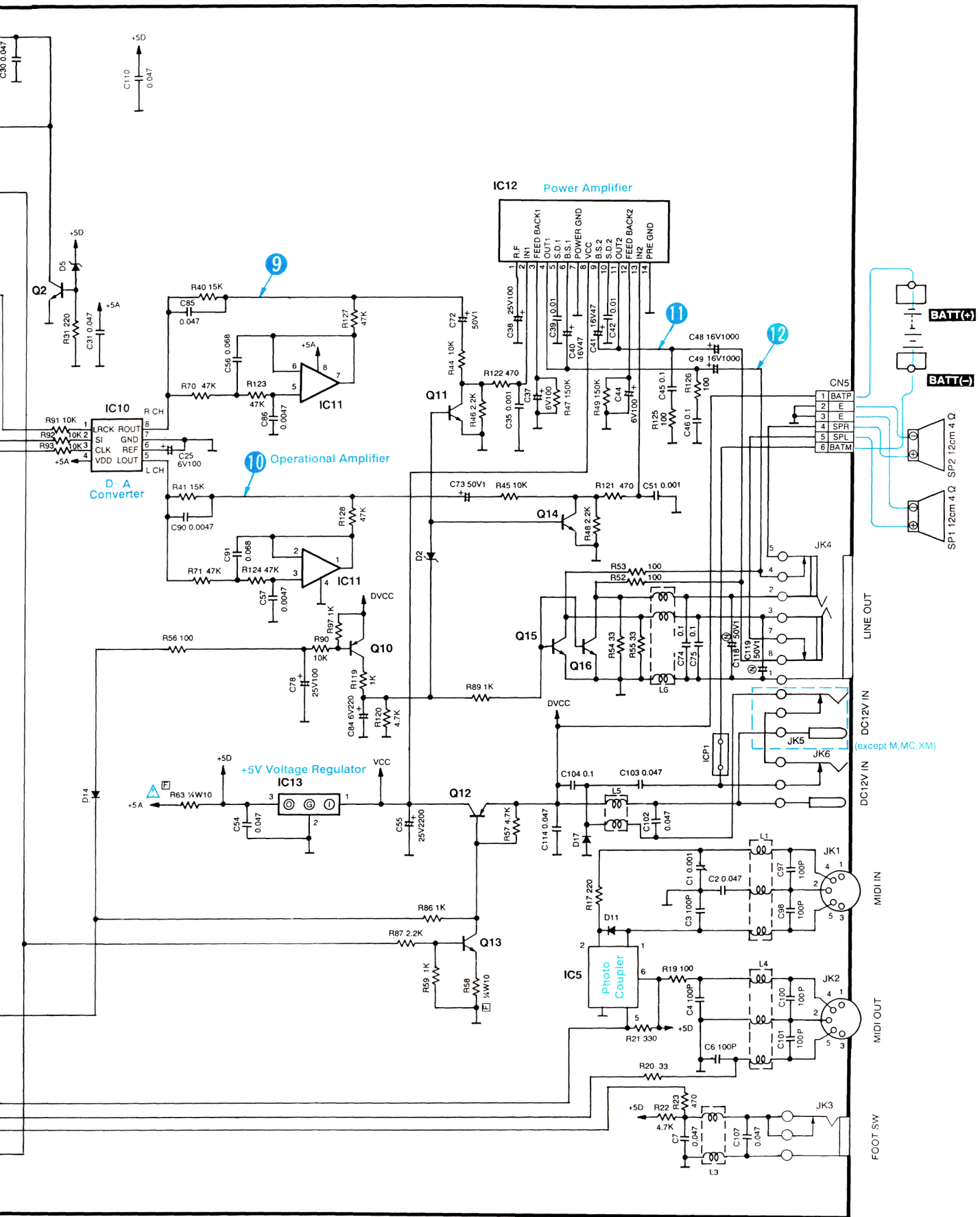

CP

CP (SXPG220221)

F  
E  
D  
C  
B  
A

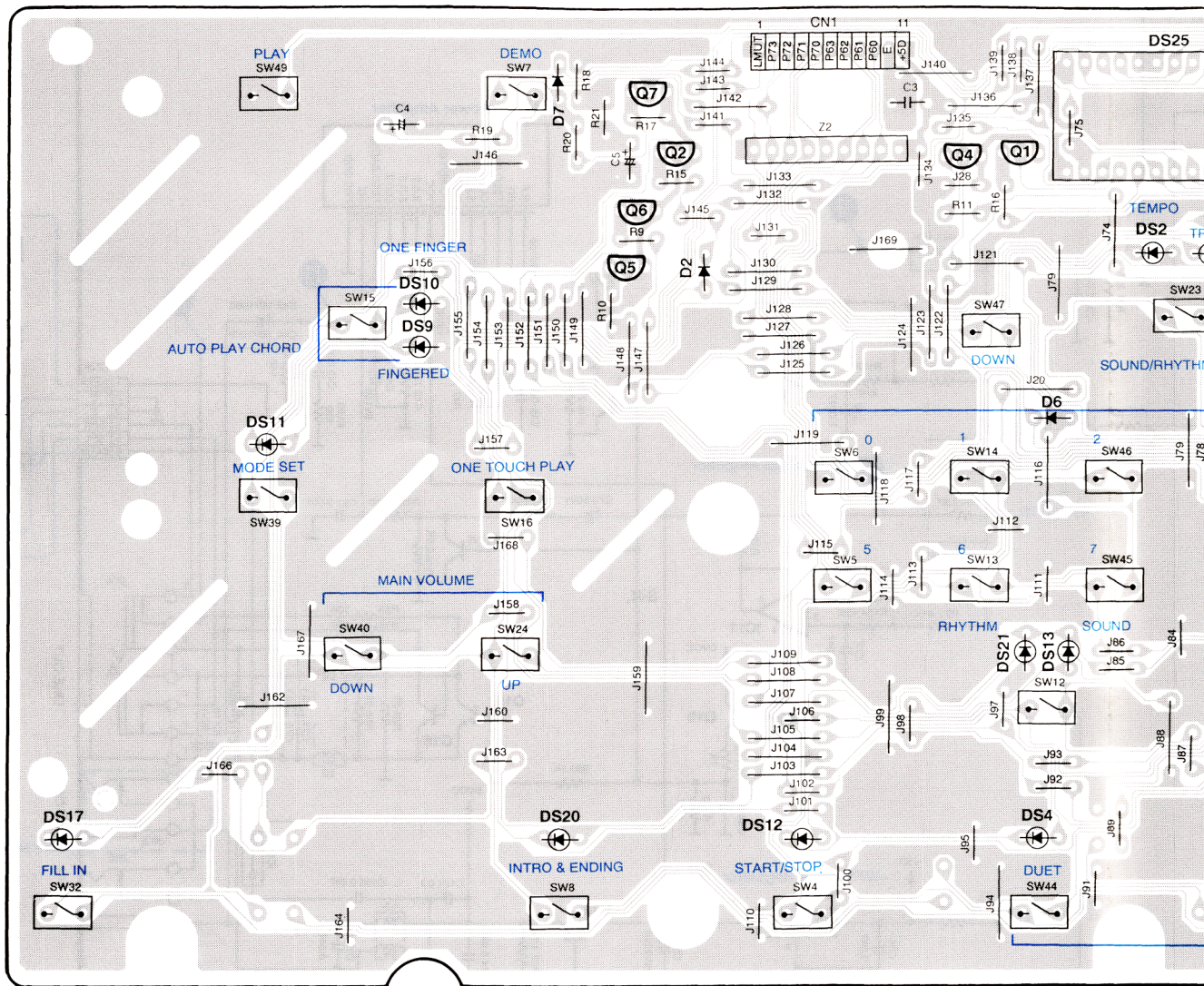

1 2 3 4 5

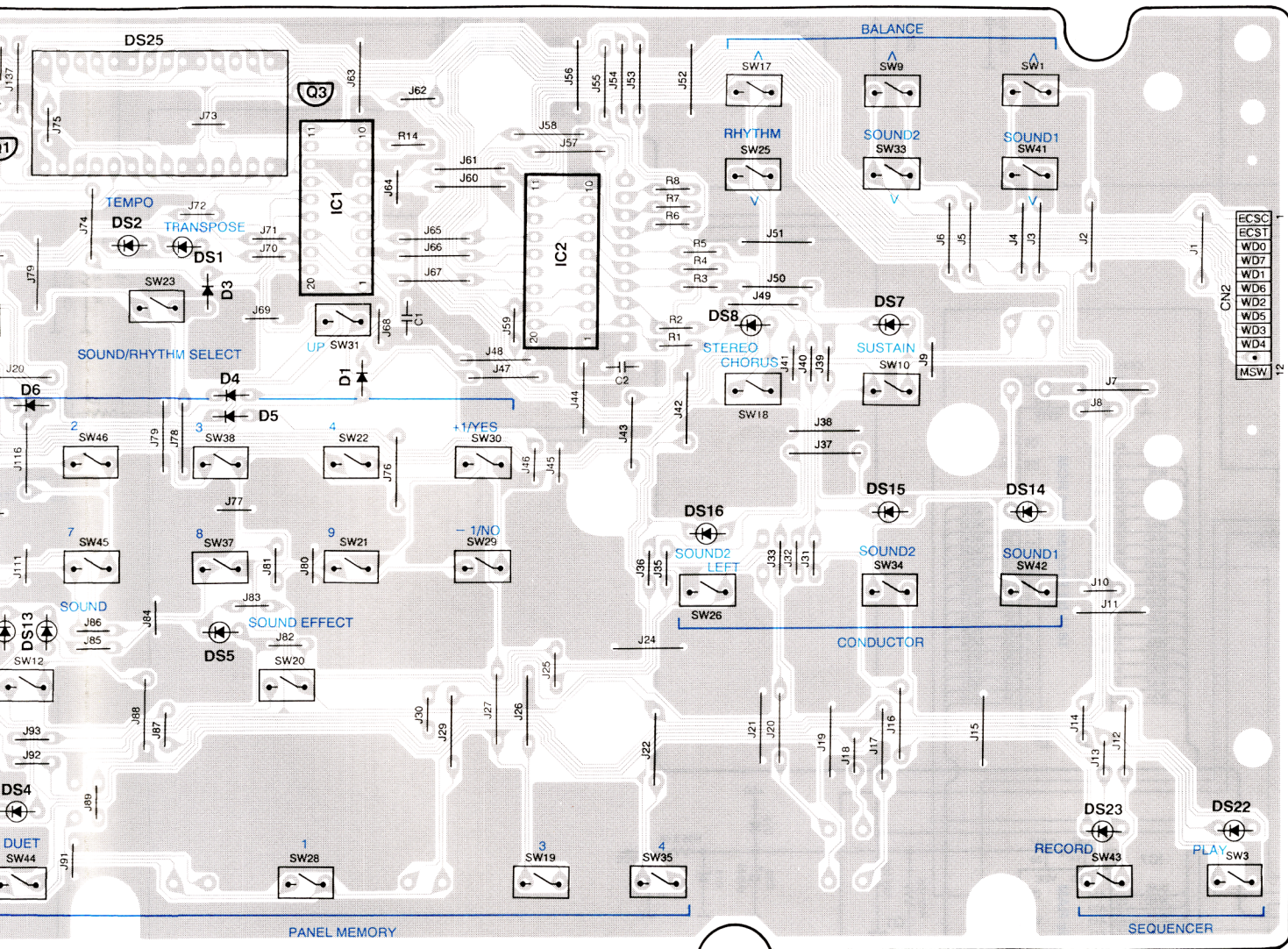

**CP**

**NOTES:**

- IC'S  
IC1, 2: HD74HC374P
- TRANSISTORS  
Q1~7: 2SA830SB
- DIODES  
D1~7: MA165  
DS1, 2, 4~5, 7, 10, 12~17, 20, 21: SEL4117RM  
D11, 22~23: SEL4417GM





# MKB 1/MKB 2/MKB 3

## MKB1 (SXPG219911A)

F

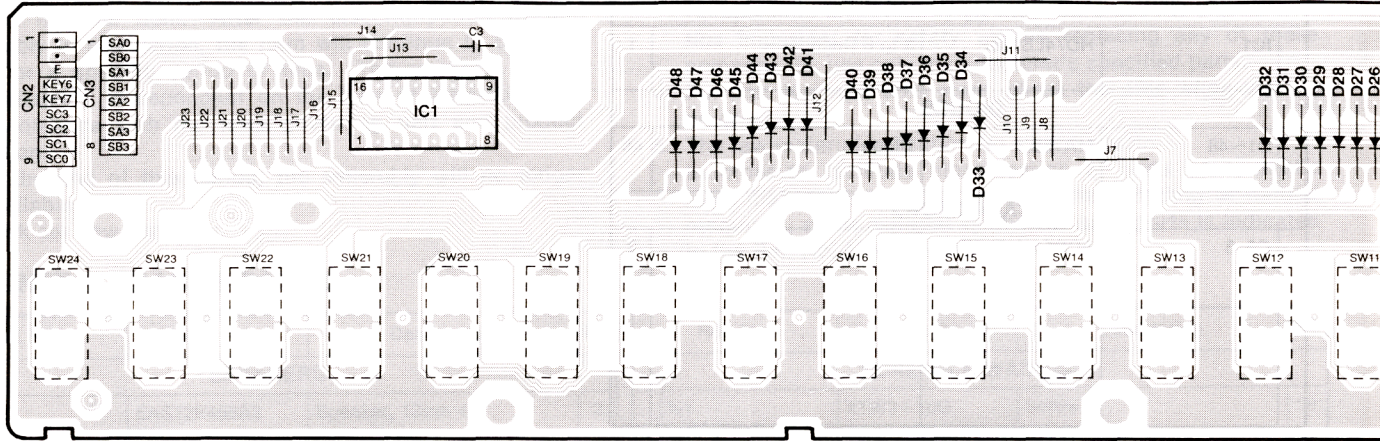

E

## MKB2 (SXPG219911B)

D

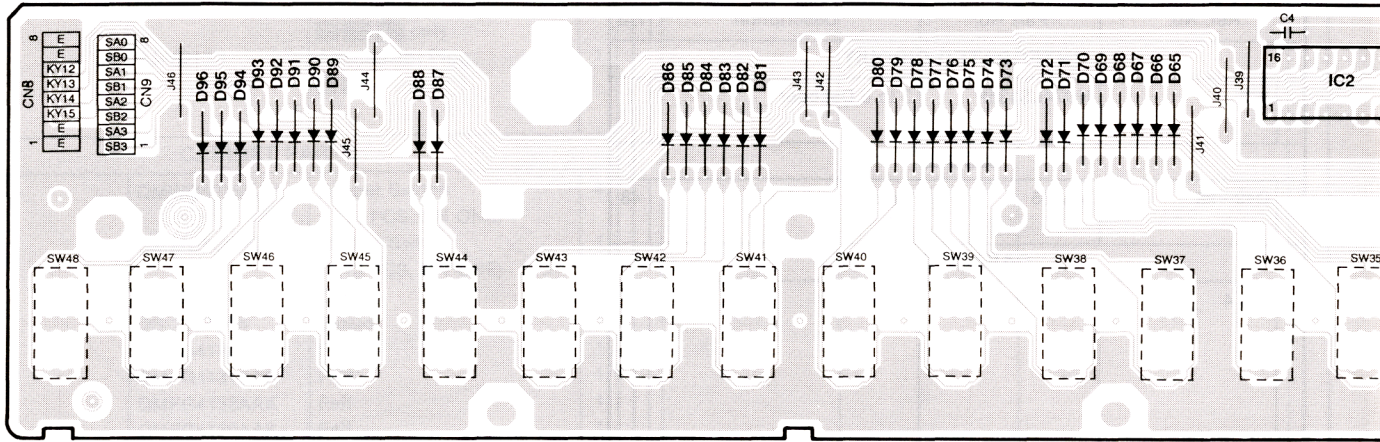

C

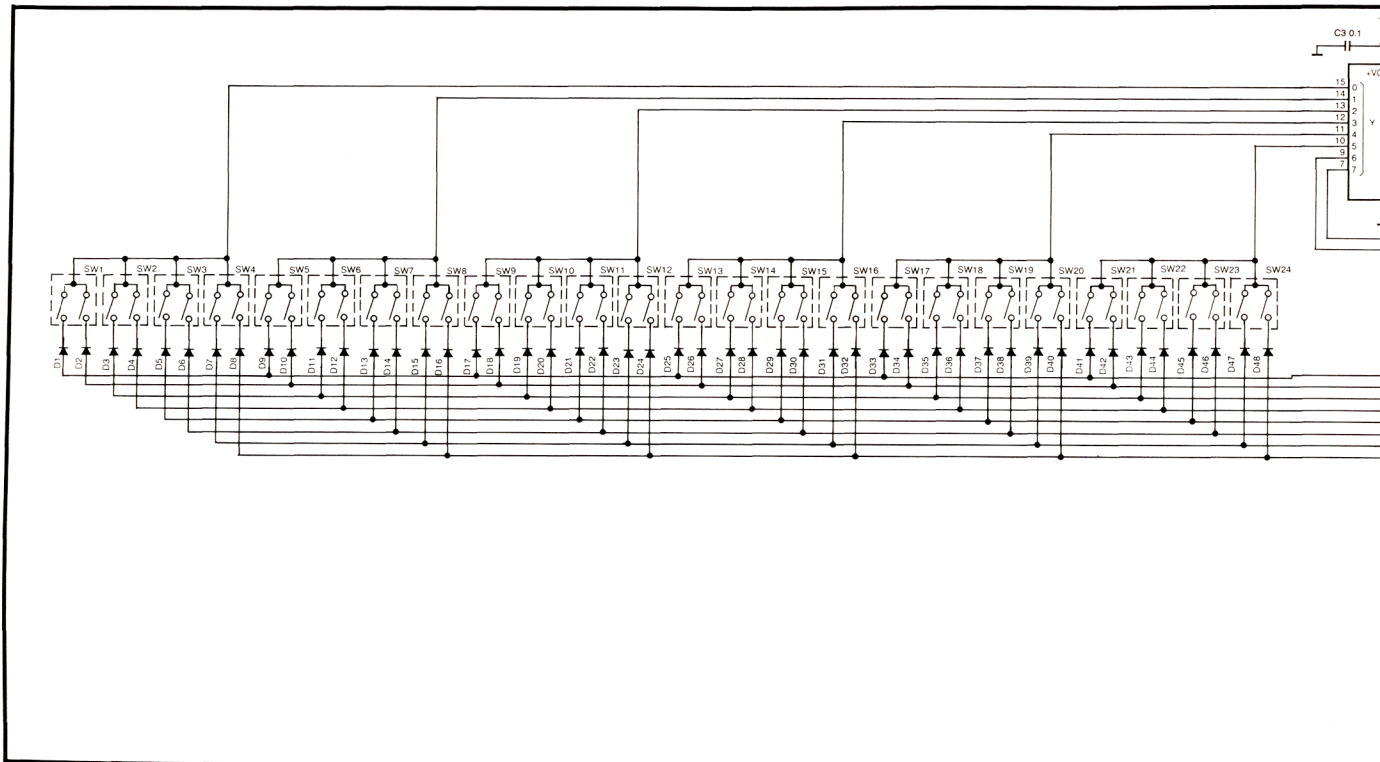

B

A

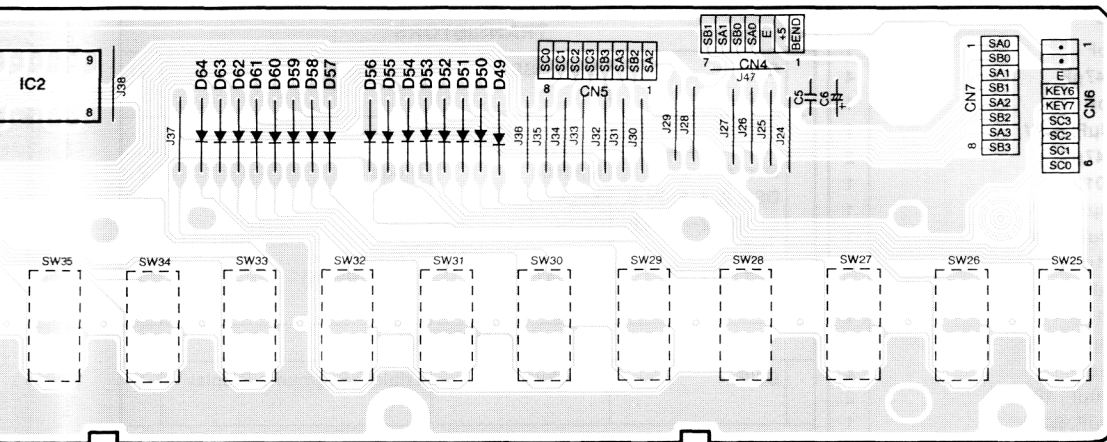
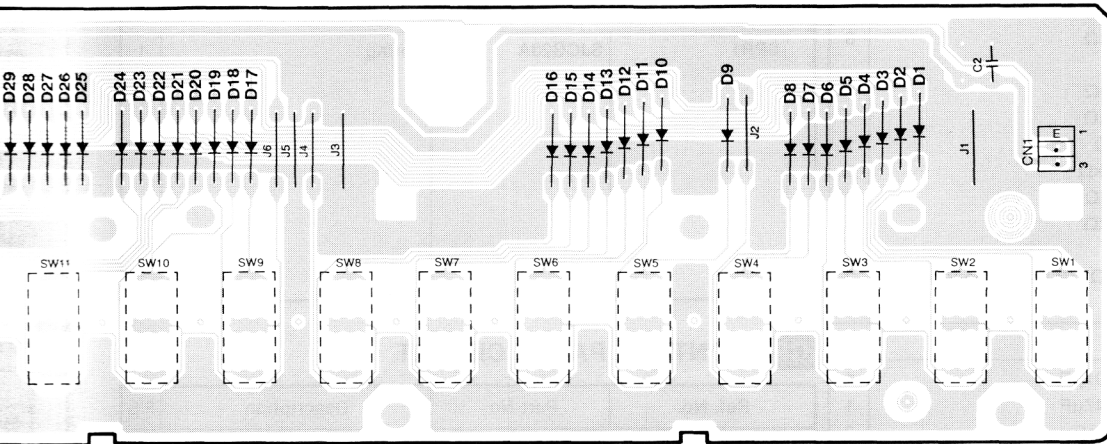

MKB3 (SXPG220011)

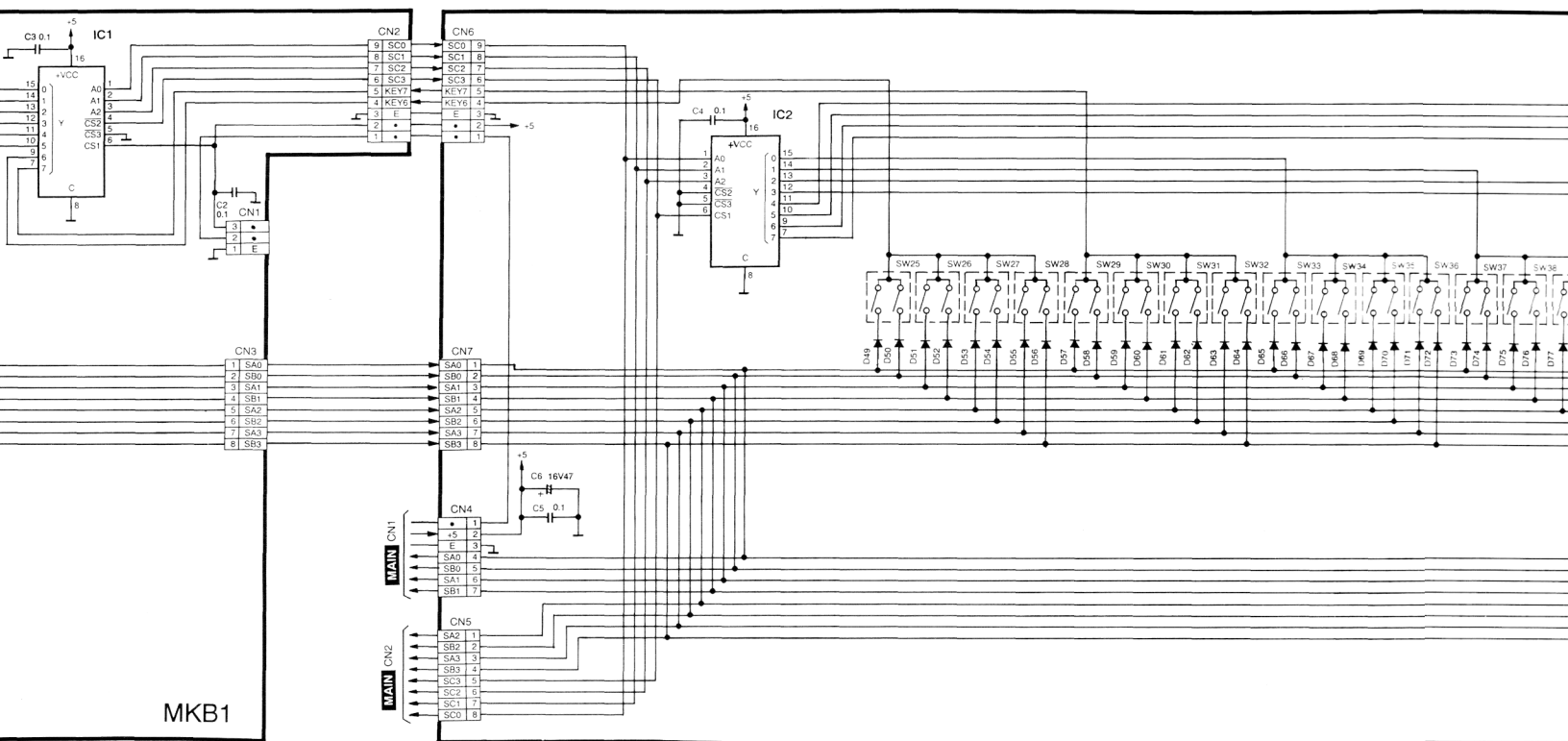
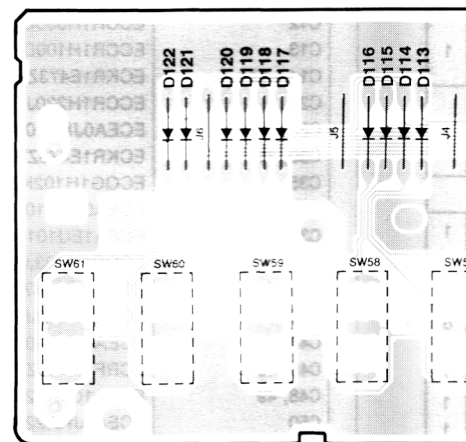

MKB1

6

7

8

9

10

**MKB1**

**NOTES:**

- IC  
IC1: HD74LS138P
- DIODES  
D1~48: MA165
- CAPACITORS  
C2, 3: ECRF1H104ZF

**MKB2**

**NOTES:**

- IC  
IC2: HD74LS138P
- DIODES  
D49~96: MA165
- CAPACITORS  
C3, 4: ECRF1H104ZF

**MKB3**

**NOTES:**

- DIODES  
D97~122: MA165

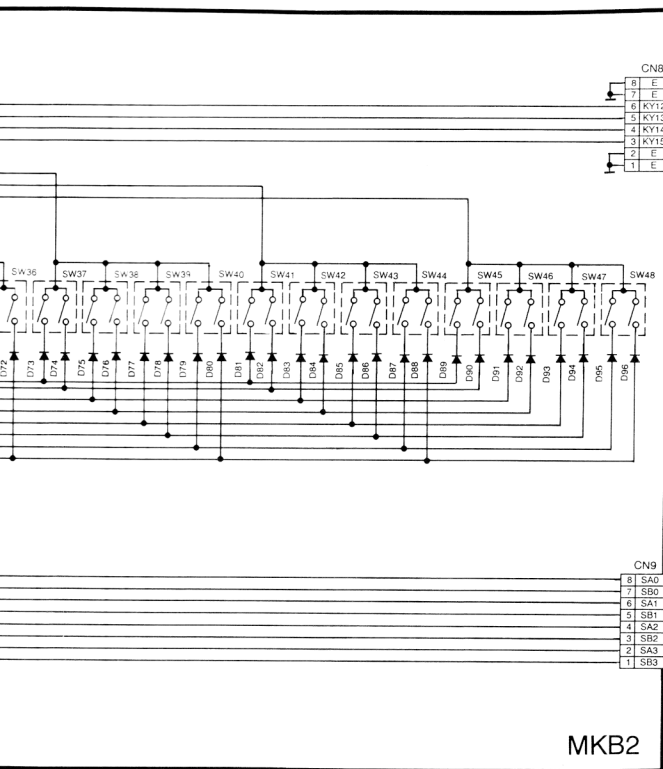
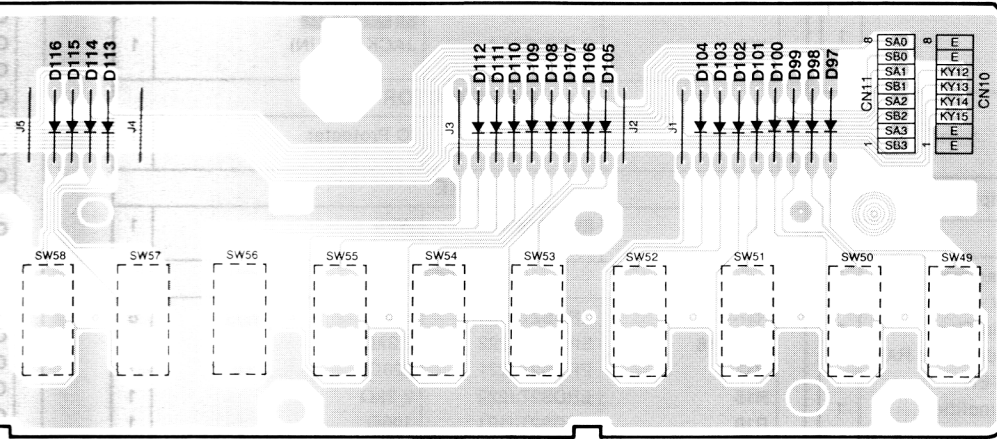

MKB2

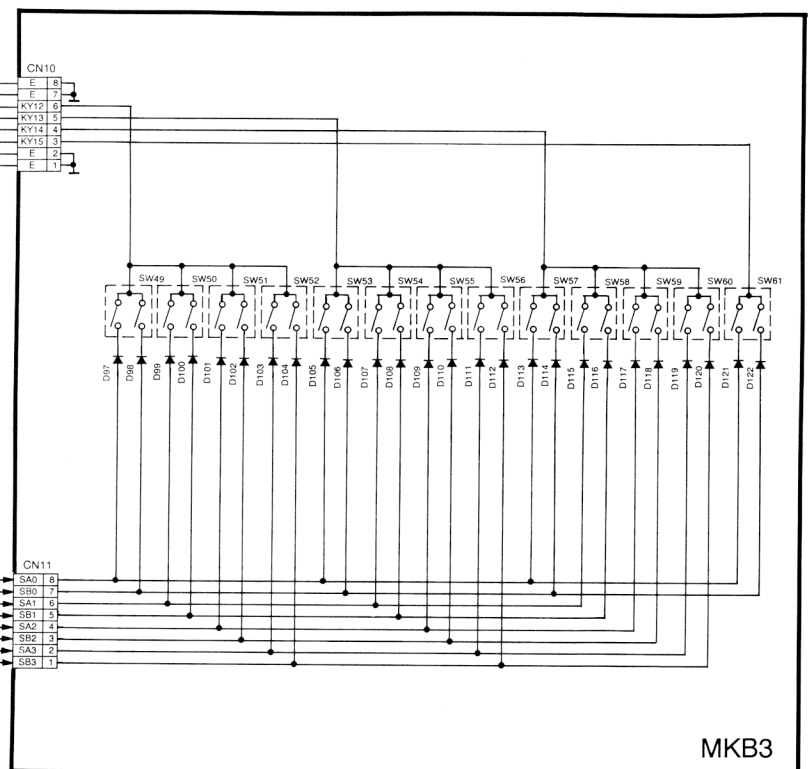

MKB3

# REPLACEMENT PARTS LIST ..... P.C.B. and Wiring Parts

## Notes:

- The marking (RTL) indicates that the Retention Time is limited for this item. After the discontinuation of this assembly in production, the item will continue to be available for a specific period of time. The retention period of availability is dependant on the type of assembly, and in accordance with the laws governing part and product retention.  
After the end of this period, the assembly will no longer be available.

- Important safety notice  
Components identified by  $\triangle$  mark have special characteristics important for safety. When replacing any of these components, use only manufacturer's specified parts.
- The "S" mark is service standard parts and may differ from production parts.
- $\bigcirc$  mark are new parts.
- For part No. with area mark, check the area when placing an order.

## PRINTED CIRCUIT BOARD

RTL	Area	Part No.	Description	P/S
$\bigcirc$ RTL	X XD XS XT	SXPG219221A	MAIN	1
$\bigcirc$ RTL	M MC XM	SXPG219241A	MAIN	1
$\bigcirc$ RTL		SXPG220111B	BATT	1
$\bigcirc$ RTL		SXPG220221	CP	1
$\bigcirc$ RTL		SXPG219911A	MKB1	1
$\bigcirc$ RTL		SXPG219911B	MKB2	1
$\bigcirc$ RTL		SXPG220011	MKB3	1

## MAIN MAIN CIRCUIT

Ref. No.	Part No.	Description	P/S
<b>INTEGRATED CIRCUITS</b>			
$\bigcirc$ IC3	QSIG03C160E5	16M bit Programmed ROM	1
IC5	SVIGTLP513	Photo Coupler	1
$\bigcirc$ IC6	HD74HC174P	Hex D-type Flip-Flops	1
$\bigcirc$ IC7	M5256BP70LL	256 K bit Pseudo Static RAM	1
$\bigcirc$ IC10	D6379GR-E1	D-A CONVERTER	1
S IC11	SVIGM5218L	Operational Amplifier	1
$\bigcirc$ IC12	LA4508	Power Amplifier	1
$\bigcirc$ IC13	UPC24M05HF	+5V Voltage Regulator	1
IC14	AN6913	Comparator	1
<b>TRANSISTORS</b>			
S Q1, 2, 11, 14~16	2SC1815GR	Transistor	6
S Q10	2SA1015-GR	2SA933STRS (SUB. Part)	1
Q12	$\triangle$ 2SA1643	Transistor	1
Q13	2SC3940ARS	Transistor	1
<b>DIODES</b>			
D1	MA4036H	Zener, 3.7V	1
$\bigcirc$ D2	MA4022	Zener, 2.2V	1
D5, 15	MA4051	Zener, 5.1V	2
D11, 13, 14, 19	MA165	Diode	4
D17	RK34LF	Diode	1
<b>OSCILLATORS</b>			
$\bigcirc$ X1	QSXG2F3200A	32MHz, Ceramic Oscillator	1
X2	QSXG2F2500A	25MHz, Ceramic Oscillator	1
<b>COMPONENT COMBINATIONS</b>			
$\bigcirc$ Z1, 2	RC9L471J101K	RC NETWORK	2
Z3	EXBPI8103JM	10k $\Omega$ $\times$ 8	1
$\bigcirc$ Z4, 5	RC5L471J101K	RC Network	2
<b>COILS &amp; LINE FILTERS</b>			
L1, 4, 6	QLQGT3T150SA	Coil	3
L3	QLQGT2T150SA	Coil	1
L5	$\triangle$ SLQG10W2D1	Coil	1

Ref. No.	Part No.	Description	P/S
<b>JACKS</b>			
JK1	SJSG1370A	MIDI IN	1
JK2	SJSG1370A	MIDI OUT	1
JK3	QJYG003AA	FOOT SW	1
JK4	SJJG100A	PHONES	1
JK5	SJJG440A	DC INPUT JACK, X XD XS XT	1
JK6	QJSG006AA	JACK (DC. IN)	1
<b>IC PROTECTOR</b>			
ICP1	ICP-N75T104	IC Protector	1
<b>WIRE</b>			
W1	SWEG660A	Wire	1
<b>RESISTORS</b>			
R1~8	ERDS2TJ333	33k $\Omega$	8
R11~16	ERDS2TJ222	2.2k $\Omega$	6
R17	ERDS2TJ221	220 $\Omega$	1
R18	ERDS2TJ222	2.2k $\Omega$	1
R19	ERDS2TJ101	100 $\Omega$	1
R20	ERDS2TJ221	220 $\Omega$	1
R21	ERDS2TJ331	330 $\Omega$	1
R22	ERDS2TJ472	4.7k $\Omega$	1
R23	ERDS2TJ471	470 $\Omega$	1
R24	ERDS2TJ222	2.2k $\Omega$	1
R28	ERDS2TJ102	1k $\Omega$	1
R29	ERDS2TJ471	470 $\Omega$	1
R31	ERDS2TJ221	220 $\Omega$	1
R32	ERDS2TJ103	10k $\Omega$	1
R33	ERDS2TJ472	4.7k $\Omega$	1
R35	ERDS2TJ562	5.6k $\Omega$	1
R36	ERDS2TJ103	10k $\Omega$	1
R37	ERDS2TJ473	47k $\Omega$	1
R40, 41	ERDS2TJ153	15k $\Omega$	2
R44, 45	ERDS2TJ103	10k $\Omega$	2
R46, 48	ERDS2TJ222	2.2k $\Omega$	2
R47, 49	ERDS2TJ154	150k $\Omega$	2
R52, 53	ERDS2TJ101	100 $\Omega$	2
R54, 55	ERDS2TJ330	33 $\Omega$	2
R56	ERDS2TJ101	100 $\Omega$	1
R57	ERDS2TJ472	4.7k $\Omega$	1
R58	$\triangle$ ERD14FJ100	10 $\Omega$ , 1/4W, Flame-Proof	1
R59	ERDS2TJ102	1k $\Omega$	1
R62	ERDS2TJ103	10k $\Omega$	1
R63	$\triangle$ ERD2FCVG100	10 $\Omega$ , 1/4W, Fuse Type	1
R70, 71	ERDS2TJ473	47k $\Omega$	2
R86	ERDS2TJ102	1k $\Omega$	1
R87	ERDS2TJ222	2.2k $\Omega$	1
R89	ERDS2TJ102	1k $\Omega$	1
R90~93	ERDS2TJ103	10k $\Omega$	4
R97	ERDS2TJ102	1k $\Omega$	1
R102, 103	ERDS2TJ222	2.2k $\Omega$	2

## BATT BATTERY CIRCUIT

Ref. No.	Part No.	Description	P/S
R104~108	ERDS2TJ221	220Ω	5
R109, 110, 113~116	ERDS2TJ103	10kΩ	6
R117	ERDS2TJ101	100Ω	1
R118	ERDS2TJ473	47kΩ	1
R119	ERDS2TJ102	1kΩ	1
R120	ERDS2TJ472	4.7kΩ	1
R121, 122	ERDS2TJ471	470Ω	2
R123, 124, 127, 128	ERDS2TJ473	47kΩ	4
R125, 126	△ ERD25FVJ2R2	2.2Ω, 1/4W, Flame-Proof	2

### CAPACITORS

C1	ECQG1H102KZ	0.001μF	1
C2	ECKR1E473ZV	0.047μF	1
C3, 4	ECCR1H101J	100pF	2
C6	ECCR1H101J	100pF	1
C7	ECKR1E473ZV	0.047μF	1
C10	ECKR1E473ZV	0.047μF	1
C12	ECCR1H030C	3pF	1
C13	ECCR1H100D	10pF	1
C14~17	ECKR1E473ZV	0.047μF	4
C24	ECCR1H220J	22pF	1
C25	ECEA0JKA101	100μF, 6.3V	1
C30, 31	ECKR1E473ZV	0.047μF	2
C35	ECQG1H102KZ	0.001μF	1
C37	ECEA0JKA101	100μF, 6.3V	1
C38	ECEA1EU101	100μF, 25V	1
C39	ECQB1H103JF	0.01μF	1
C40, 41	ECEA1CKA470	47μF, 16V	2
C42	ECQB1H103JF	0.01μF	1
C44	ECEA0JKA101	100μF, 6.3V	1
C45, 46	ECRF1H104ZF	0.1μF	2
C48, 49	ECEA1CU102	1000μF, 16V	2
C50	ECEA0JKA221	220μF, 6.3V	1
C51	ECQG1H102KZ	0.001μF	1
C54	ECKR1E473ZV	0.047μF	1
C55	ECEA1EU222	2200μF, 25V	1
C56	ECQB1H683JF	0.068μF	1
C57	ECQG1H472KZ	0.0047μF	1
C61~64	ECKR1E473ZV	0.047μF	4
C66	ECKR1E473ZV	0.047μF	1
C70	ECKR1E473ZV	0.047μF	1
C72, 73	ECEA1HKA010	1μF, 50V	2
C74, 75	ECEA1HKN010	1μF, 50V	2
C78	ECEA1EU101	100μF, 25V	1
C81	ECKR1E473ZV	0.047μF	1
C84	ECEA0JKA221	220μF, 6.3V	1
C85, 86	ECQG1H472KZ	0.0047μF	2
C88	ECCR1H221J	220pF	1
C89	ECEA1CKA470	47μF, 16V	1
C90	ECQG1H472KZ	0.0047μF	1
C91	ECQB1H683JF	0.068μF	1
C92~94	ECCR1H221J	220pF	3
C95	ECKR1E473ZV	0.047μF	1
C97, 98	ECCR1H101J	100pF	2
C100, 101	ECCR1H101J	100pF	2
C102, 103	ECKR1E473ZV	0.047μF	2
C104	ECRF1H104ZF	0.1μF	1
C107, 108, 109	ECKR1E473ZV	0.047μF	3
C110, 111	ECKR1E473ZV	0.047μF	2
C114, 115	ECKR1E473ZV	0.047μF	2

Ref. No.	Part No.	Description	P/S
<b>SPRING</b>			
SPR1	SJCG20A	Spring	1

## CP CONTROL PANEL CIRCUIT

Ref. No.	Part No.	Description	P/S
<b>INTEGRATED CIRCUITS</b>			
○ IC1, 2	HD74HC374P	Hex Buffers	2
<b>TRANSISTORS</b>			
Q1~7	2SA830SB	Transistor	7
<b>DIODES</b>			
D1~7	MA165	Diode	7
DS1, 2, 4, 5, 7~9, 10, 12~17, 20, 21	SEL4117RM	LED (RED)	16
DS11, 22, 23	SEL4417GM	LED (GREEN)	3
<b>LCD DISPLAY</b>			
D625	LB603VF	Triple 8 Segments Display	1
<b>COMPONENT COMBINATION</b>			
Z2	EXBPI8103JM	10kΩ × 8	1
<b>SWITCHES</b>			
S1, 3~10, 12~26, 28~37, 39~47, 49	EVQ21507K	Push Switch	44
<b>RESISTORS</b>			
R1~8	ERDS2TJ101	100Ω	8
R9~11	ERDS2TJ103	10kΩ	3
R14~17	ERDS2TJ103	10kΩ	4
R18	ERDS2TJ102	1kΩ	1
R19	ERDS2TJ101	100Ω	1
R20	ERDS2TJ153	15kΩ	1
R21	ERDS2TJ101	100Ω	1
<b>CAPACITORS</b>			
C1~3	ECRF1H104ZF	0.1μF	3
C4	ECEA0JKA330	33μF, 6.3V	1
C5	ECEA0JKA101	100μF, 6.3V	1

**MKB1 MANUAL KEYBOARD 1 CIRCUIT**

Ref. No.	Part No.	Description	P/S
<b>INTEGRATED CIRCUIT</b>			
IC1	HD74LS138P	3 to 8 Decoder	1
<b>DIODES</b>			
D1~48	MA165	Diode	48
<b>CAPACITORS</b>			
C2, 3	ECRF1H104ZF	0.1 $\mu$ F	2

**MKB2 MANUAL KEYBOARD 2 CIRCUIT**

Ref. No.	Part No.	Description	P/S
<b>INTEGRATED CIRCUIT</b>			
IC2	HD74LS138P	3 to 8 Decoder	1
<b>DIODES</b>			
D49~96	MA165	Diode	48
<b>CAPACITORS</b>			
C3, 4	ECRF1H104ZF	0.1 $\mu$ F	2

**MKB3 MANUAL KEYBOARD 3 CIRCUIT**

Ref. No.	Part No.	Description	P/S
<b>DIODES</b>			
D97~122	MA165	Diode	26

**WIRING PARTS**

Ref. No.	Part No.	Description	P/S
○ W1	QEXGRA1020C	Connector with Wire	1
○ W2	QEUGSCW12BZ	Connector with Wire	1
○ W4	QEUGS7W20BZ	Connector with Wire	1
○ W5	QEUGS8W20BZ	Connector with Wire	1
○ W6	QEUGSBW20BZ	Connector with Wire	1
○ W7	QEXGEH06080B	Connector with Wire	1

# CABINET PARTS LOCATION

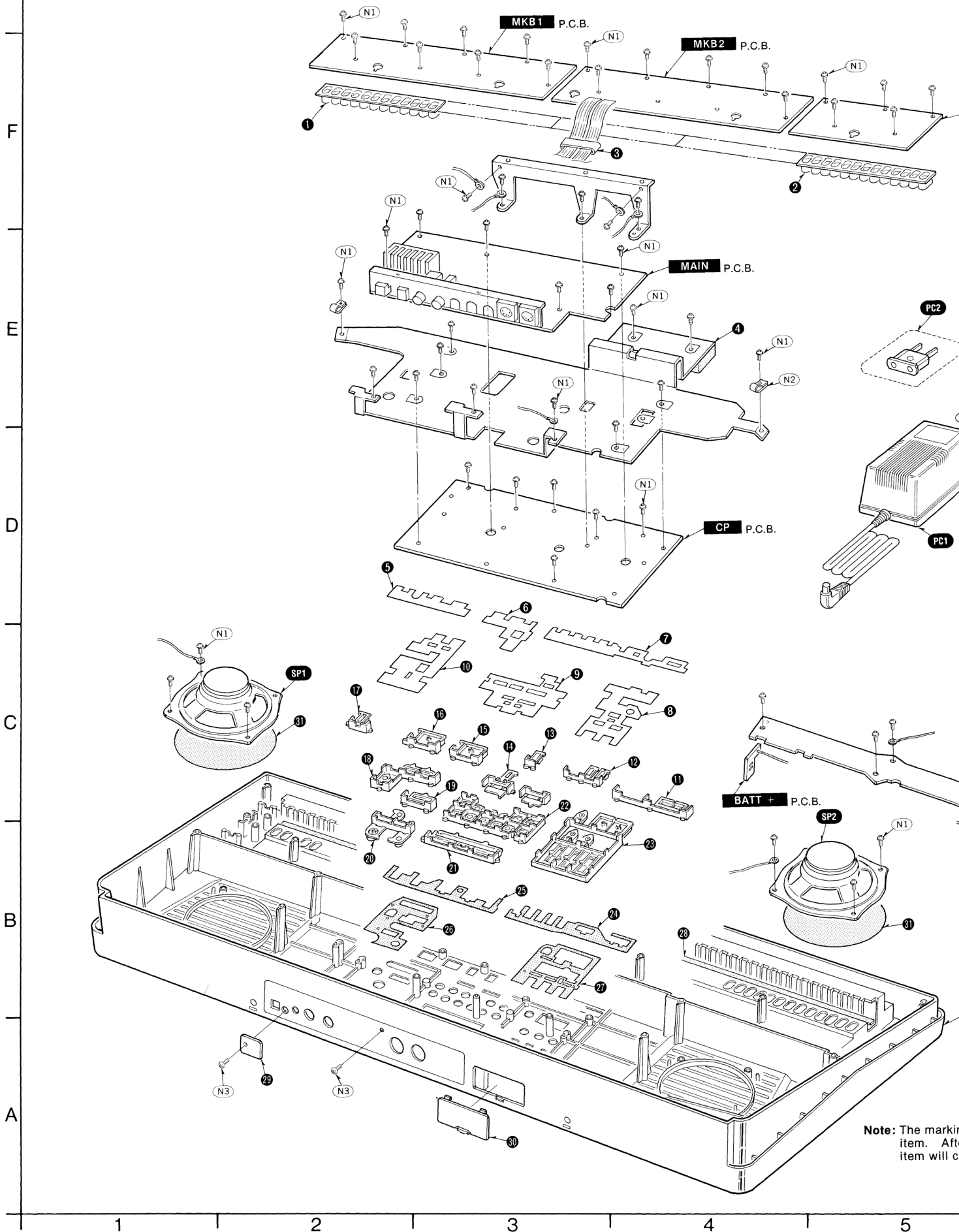

Note: The marking item. After item will co

MKB3 P.C.B.

PC2

PC1

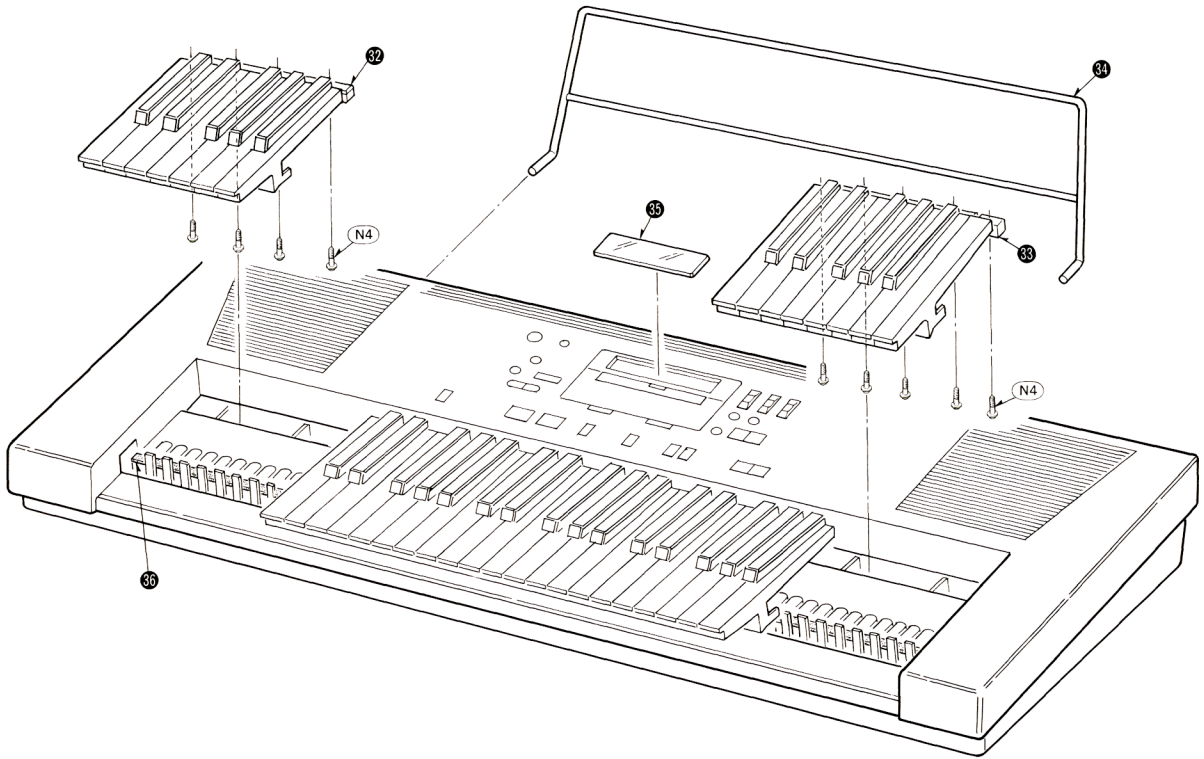

BATT - P.C.B.

※QKQGK013AAZK

38

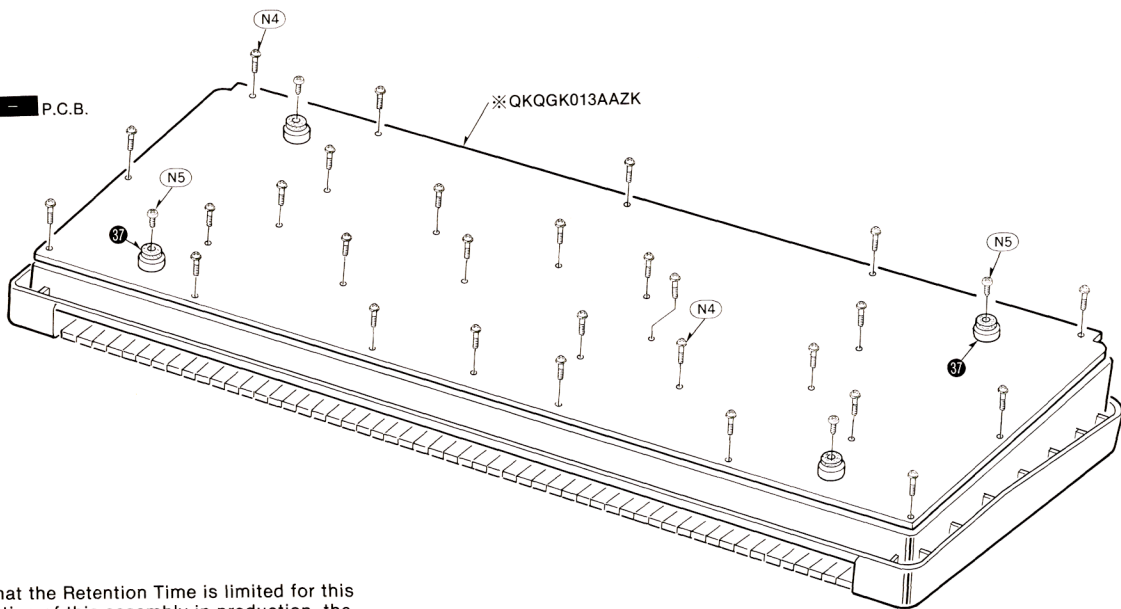

The marking (※) indicates that the Retention Time is limited for this item. After the discontinuation of this assembly in production, the item will continue to be available for a specific period of time.

# REPLACEMENT PARTS LIST ..... Cabinet and Chassis Parts

**Notes:**

1. The marking (RTL) indicates that the Retention Time is limited for this item. After the discontinuation of this assembly in production, the item will continue to be available for a specific period of time. The retention period of availability is dependant on the type of assembly, and in accordance with the laws governing part and product retention.  
After the end of this period, the assembly will no longer be available.
2. ○ mark are new parts.

3. Important safety notice  
Components identified by △ mark have special characteristics important for safety. When replacing any of these components, use only manufacturer's specified parts.
4. For part No. with area mark, check the area when placing an order.
5. The raw material indication for synthtic resin  
In order to facilitate classification of parts of synthetic resin manufacture and to promote the recycling of natural resources, a raw material symbol for such parts is indicated in the Ref. No./Material column.

**■ CABINET & CHASSIS PARTS**

Ref. No.	Part No.	Description	P/S
<b>SPEAKERS</b>			
SP1, 2	EAS12P458A3	Speaker, 12cm 4Ω	2
<b>POWER CORD &amp; PLUG</b>			
PC1	△ QFAG006AA	AC Adapter, M MC XM only	1
PC2	△ SJP5213-1	Attachment Plug, X XT	1
<b>CABINET PARTS</b>			
○ 1	QMWG6015BAK	Rubber Switch (12 PCS. ON ONE)	4
○ 2	QMWG6014BAK	Rubber Switch (13 PCS. ON ONE)	1
○ 3	QLZG010A	Core	1
○ 4	QSCG073AK	Shield	1
○ 5	QMFG4142AAK	Felt	1
○ 6	QMFG4131AAK	Felt	1
○ 7	QMFG4132AAK	Felt	1
○ 8	QMFG4130AAK	Felt	1
○ 9	QMFG4133AAK	Felt	1
○ 10	QMFG4129AAK	Felt	1
○ 11	QGUG1287BA01	Button	1
○ 12	QGUG1288BA	Button	1
○ 13	QGUG1291AB	Button	1
○ 14	QGUG1290AA	Botton	1
○ 15	QGUG1294AA	Botton	1
○ 16	QGUG1297BA	Button	1
○ 17	QGUG1297CA	Button	1
○ 18	QGUG1285AA	Botton	1
○ 19	QGUG1296AA	Botton	1
○ 20	QGUG1289AA	Botton	1
○ 21	QGUG1286AA	Botton	1
○ 22	QGUG1283AB	Button	1
○ 23	QGUG1284AA	Botton	1
○ 24	QMRG5070AAK	Felt	1
○ 25	QMRG5069AAK	Felt	1
○ 26	QMRG5071AAK	Felt	1
○ 27	QMRG5072AAK	Felt	1
○ 28	SHSG1970A	Felt	1
○ 29	QKSGF007AA	DC IN Cover	1
○ 30	QKSGF014AAK	Battery Cover	1
○ 32	ABS QMWG9020AAK	12 Keys	4
○ 33	ABS QMWG9021AAK	13 Keys	1
○ 34	QGAG3003AAK	Music Rack	1
○ 35	QKWG017AAK	Display Panel	1
○ 36	QMFG1141AA	Felt	1
○ 37	SHRG2160AK	Foot	4
○ 38	PS QYPG1044CAK	Control Panel	1
○ 31	[ QMFG4128AAK	Speaker Net	2

Ref. No.	Part No.	Description	P/S
<b>SCREWS &amp; WASHERS</b>			
N1	XTW3+10Q	Screw	18
N2	SNEG2620A	Speed Nut	2
N3	XTB3+14JFZ	Screw	2
N4	XTW3+20Q	Screw	27
N5	XTB3+12AFZ	Screw	4

# PACKING

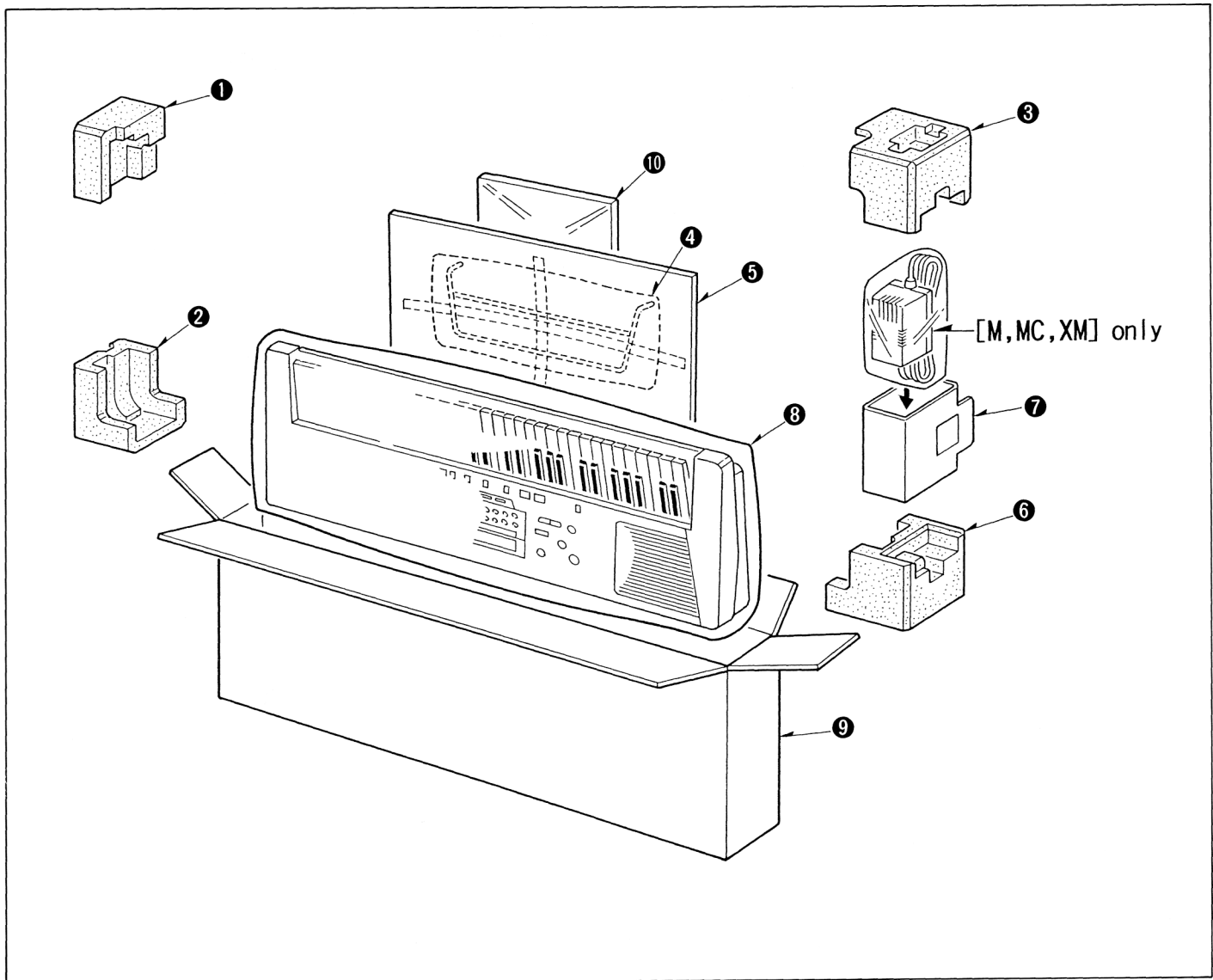

## PACKING PARTS

Ref. No.	Part No.	Description	P/S	Ref. No.	Part No.	Description	P/S
<b>PACKING PARTS</b>							
○ 1	<input type="checkbox"/> PS QPNG0450AAK	Pad	1	○ 10	QQFGKN450DA	Operating instruction manual, <input checked="" type="checkbox"/> D <input checked="" type="checkbox"/> S	1
○ 2	<input type="checkbox"/> PS QPNG0448AAK	Pad	1	○ 10-1	<input type="checkbox"/> QQTG0274A	ENGLISH	1
○ 3	<input type="checkbox"/> PS QPNG0451AAK	Pad	1	○ 10	QQFGKZ450BA	Operating Instruction Manual, <input checked="" type="checkbox"/> M	1
○ 4	<input type="checkbox"/> PE QPHG017AAK	Polyethylene Cover	1	○ 10-1	<input type="checkbox"/> QQTG0274A	ENGLISH	1
○ 5	QPNG0473AAK	Cardboard	1	○ 10-2	<input type="checkbox"/> QQTG0276A	ESPAÑOL	1
○ 6	<input type="checkbox"/> PS QPNG0449AAK	Pad	1	○ 10	QQFGKZ450EA	Operating Instruction Manual, <input checked="" type="checkbox"/> X	1
○ 7	QPNG0475AA	Pad, <input checked="" type="checkbox"/> M <input checked="" type="checkbox"/> MC <input checked="" type="checkbox"/> XM	1	○ 10-1	<input type="checkbox"/> QQTG0274A	ENGLISH	1
○ 8	QPHG074AAK	Protection Cover	1	○ 10-2	<input type="checkbox"/> QQTG0276A	ESPAÑOL	1
○ 9	QPGG0276AEK	Carton	1	○ 10-3	<input type="checkbox"/> QQTG0277A	中文	1
<b>OPERATING INSTRUCTION MANUAL</b>				○ 10	QQFGKZ450FA	Operating Instruction Manual, <input checked="" type="checkbox"/> T	1
○ 10	QQFGKZ450AA	Operating Instruction Manual, <input checked="" type="checkbox"/> M	1	○ 10-1	<input type="checkbox"/> QQTG0277A	中文	1
○ 10-1	<input type="checkbox"/> QQTG0273A	ENGLISH	1				
○ 10	QQFGKZ450CA	Operating Instruction Manual, <input checked="" type="checkbox"/> MC	1				
○ 10-1	<input type="checkbox"/> QQTG0274A	ENGLISH	1				
○ 10-2	<input type="checkbox"/> QQTG0275A	FRANCAIS	1				



