

DAISY WHEEL PRINTER
HR-40
INSTRUCTION MANUAL

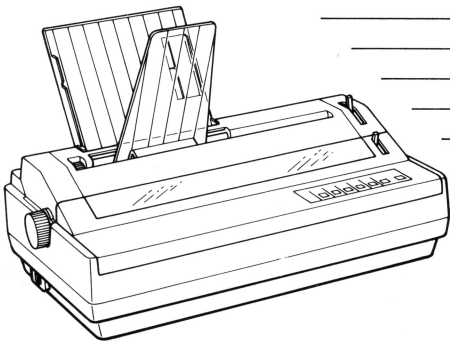

Federal Communications Commission Compliance Notice

This equipment generates and uses radio frequency energy and if not installed and used properly, that is, in strict accordance with the manufacturer's instructions, may cause interference to radio and television reception. It has been type tested and found to comply with the limits for a Class B computing device in accordance with the specifications in Subpart J of Part 15 of FCC rules, which are designed to provide reasonable protection against such interference in a residential installation. However, there is no guarantee that interference will not occur in a particular installation. If this equipment does cause interference to radio or television reception, which can be determined by turning the equipment off and on, the user is encouraged to try to correct the interference by one or more of the following measures:

- reorient the receiving antenna
- relocate the computer with respect to the receiver
- move the computer away from the receiver
- plug the computer into a different outlet so that computer and receiver are on different branch circuits.

If necessary, the user should consult the dealer or an experienced radio/television technician for additional suggestions.

A shielded interface cable must be used according to FCC 15.838D. It is recommended that the cable length does not exceed 71 inches (1.8 m)

Table of Contents

	Page
1. UNPACKING	1
2. NAME OF EACH PART	3
3. CONNECTING TO YOUR COMPUTER	4
4. CONTROL PANEL	5
5. SETTING THE DIP SWITCHES	7
6. REPLACING THE RIBBON CASSETTE	12
7. INSTALLING THE OPTIONAL COLOR RIBBON SPOOL	14
8. CHANGING THE DAISY WHEEL	15
9. LOADING PAPER	16
9.1 Paper Selection	16
9.2 SHEET Mode	16
9.3 CSF Mode	18
• Preparation	18
• Setting a Stack of Paper	19
• Operating the Cut Sheet Feeder by Control Switch	20
• Operating the Cut Sheet Feeder by Control Code	20
9.4 FORMS Mode	21
• Paper Setting	21
• Loading Continuous Forms	23
• Paper Parking	24
9.5 DBSF Mode	25
• Installation	25
• Operating the dual bin sheet feeder	29
10. VERSATILE FUNCTIONS	30
10.1 Direct Printing	30
10.2 Copy Function	30
10.3 Buffer Clear	30
10.4 Self-Test Function	31
10.5 Hex Dump Function	31
10.6 Detection Functions	32
• Top Cover Open	32
• Paper Empty (PE)	32
• Ribbon End (RE)	32

11. CONTROL CODES	33
ASCII Code	33
Programming	33
Control Characters	33
Setting Format	34
Selecting Versatile Functions	38
Control Commands in DBSF Mode	39
Printing in the Graphic Mode	41
APPENDIX A TABLE OF ESC SEQUENCES	42
APPENDIX B INTERFACE SPECIFICATIONS	44
Centronics Parallel Interface	44
RS-232C Serial Interface	45
APPENDIX C SERIAL INTERFACE SAMPLE CONNECTION	46
Interfacing with the IBM PC and PC XT	46
Interfacing with the Apple IIc	47
Interfacing with the Apple Macintosh	49
APPENDIX D ASCII CODE TABLES (by Language Group)	51
APPENDIX E TROUBLESHOOTING AND MAINTENANCE	55
APPENDIX F PRINTER SPECIFICATIONS	57
APPENDIX G OPTIONS AND ACCESSORIES	58

1. UNPACKING

Step 1

Unpack the printer and remove the polystyrene packing and vinyl cover.

Note: The CSF attachment cover, FORMS Ejection Guide, paper tray and paper stacker are detached from the main body and packed separately.

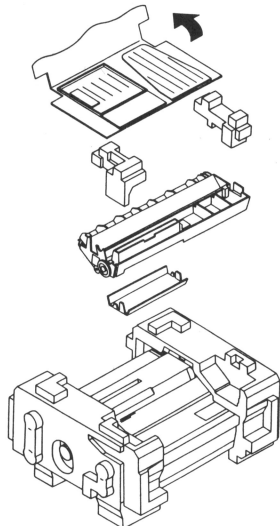

Step 2

Open the top cover.

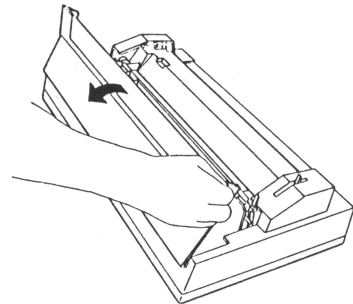

Step 3

Remove the right print head stopper.
Remove the ribbon cassette stopper.

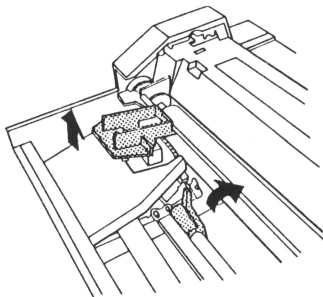

Step 4

Move the print head to the right by grasping it by hand.

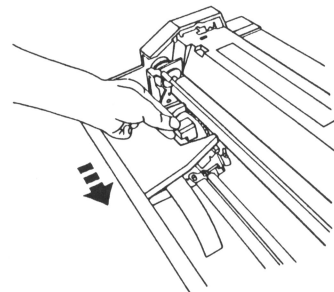

Step 5

Remove the left print head stopper by pulling it up.

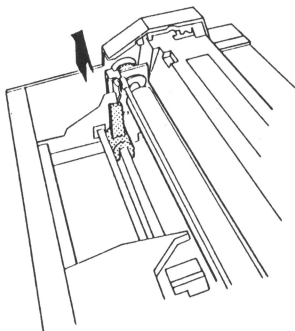

Step 6

Pull the tab out of the ribbon cassette.

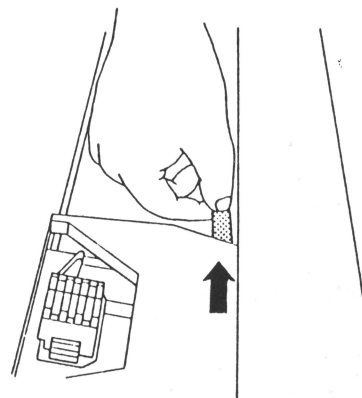

All of the materials have now been unpacked and the setup procedure can now be started.

Step 7

Remove the gear cover.

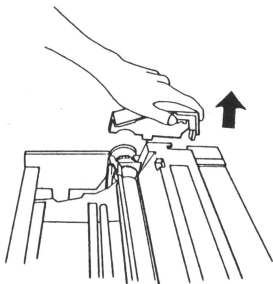

Step 8

Attach the CSF attachment cover.

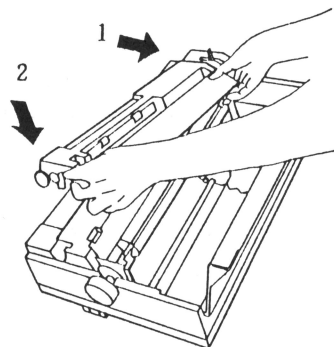

Step 9

Attach the gear cover.

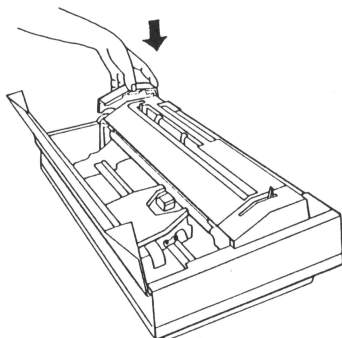

Step 10

Close the top cover and attach the paper tray and paper stacker.

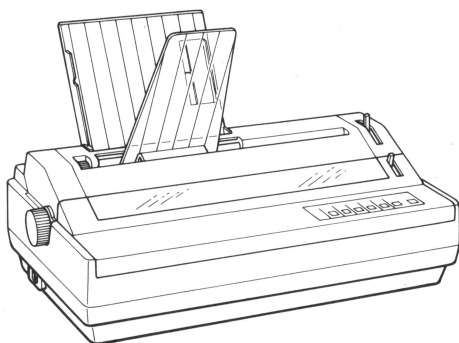

Step 11

Now you are ready to proceed.

Note: This depends on the type of paper used and the paper handling mode.

2. NAME OF EACH PART

[Front View]

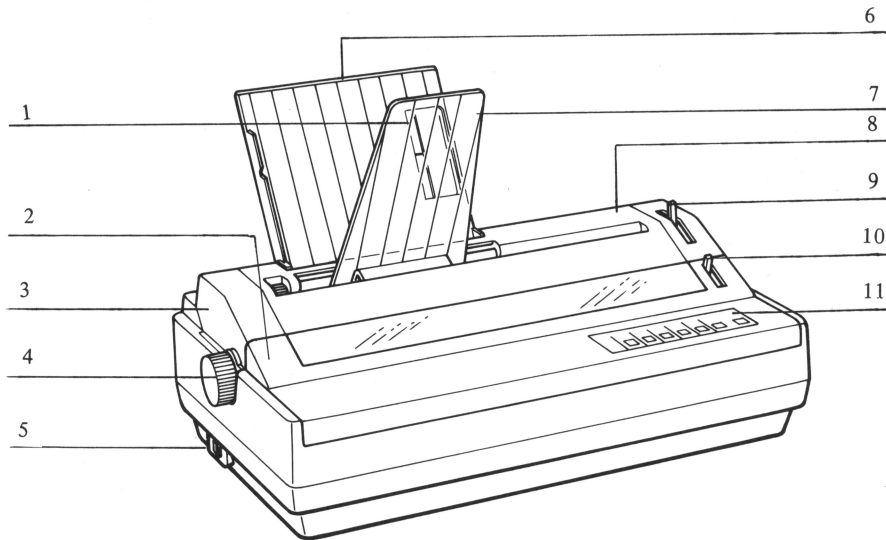

[Back View]

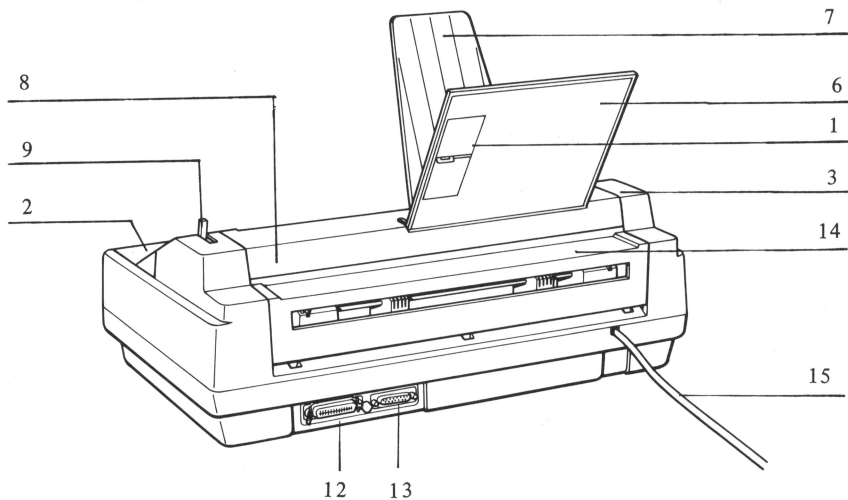

- 1 Paper guide
- 2 Top cover
- 3 Gear cover
- 4 Platen knob
- 5 Power switch
- 6 Paper stacker
- 7 Paper tray

- 8 CSF attachment cover
- 9 Paper release lever
- 10 Paper bail release lever
- 11 Control panel
- 12 Centronics parallel interface port
- 13 RS-232C serial interface port
- 14 Tractor cover
- 15 Power cord

3. CONNECTING TO YOUR COMPUTER

Before you connect the printer to your computer, you have to consider two things: interface and cable. This printer is equipped with a serial interface RS-232C and the Centronics parallel interface.

You can connect your printer to your computer by using the proper interface cable according to the type of interface. But be sure to check the connector and the pin configuration.

You should have the on-the-market shielded cable which can be used to connect this printer to your computer. If the cable connectors have a different pin configuration from the computer side and the printer side, communications cannot be accomplished. Also remember that communications can be carried out under the same protocol or rule between the printer and the computer. You have to match the DIP switch settings. Because details of connection depend on the configuration, refer to the computer manual.

Note

You must use a shielded cable to satisfy the FCC standard.

Warning

You should turn off both the printer and the computer before you connect and disconnect them; otherwise, they may be damaged electrically.

Step 1

Make sure that both the printer and the computer are turned off.

Step 2

Make sure of the interface you use, serial or parallel. Match the interface by DIP switch changing the INTERFACE.

(See the following figure.)

Note

See Chapter 5, for detail about RS-232C parity/ baud rate/ data length. (P. 8)

Step 3

Attach the shielded interface cable to the interface port of your computer.

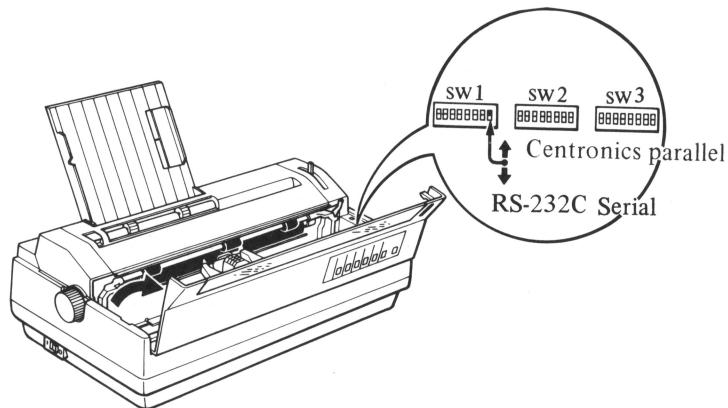

Step 4

Attach the cable to the printer.

- In case of parallel interface port:
Snap the fixing metal ring to the printer.

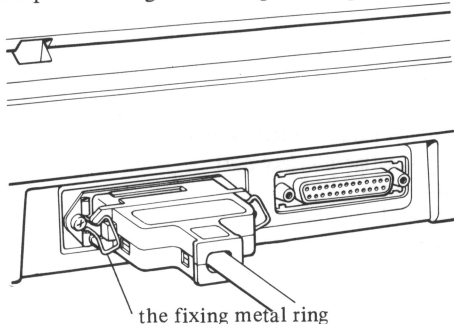

- In case of serial interface port:
Fix the connector to the printer by screwing it in.

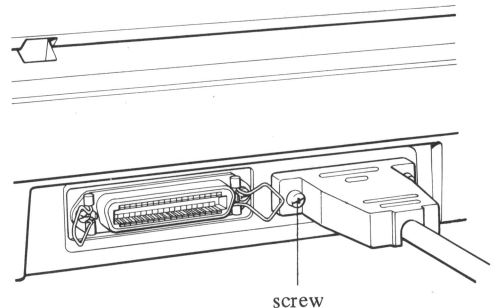

4. CONTROL PANEL

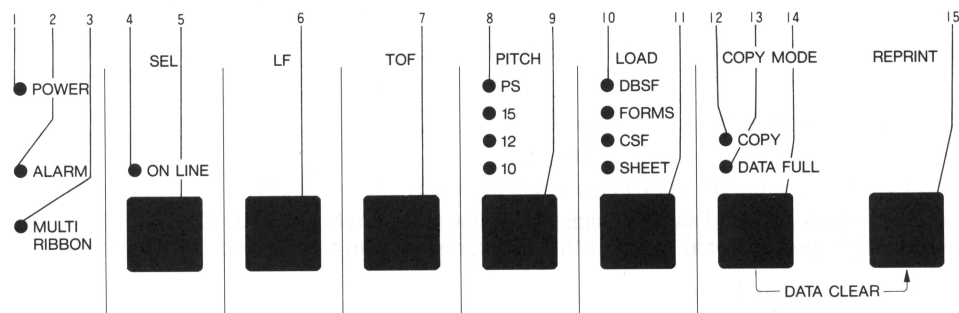

- | | | | |
|---|--------------------|----|--------------------|
| 1 | POWER Lamp | 9 | PRINT PITCH Switch |
| 2 | ALARM Lamp | 10 | LOAD Lamp |
| 3 | MULTI RIBBON Lamp | 11 | LOAD Switch |
| 4 | ON LINE Lamp | 12 | COPY Lamp |
| 5 | SELECT Switch | 13 | DATA FULL Lamp |
| 6 | LINE FEED Switch | 14 | COPY MODE Switch |
| 7 | TOP OF FORM Switch | 15 | REPRINT Switch |
| 8 | PRINT PITCH Lamp | | |

● POWER Lamp

* Lights when power is supplied to the printer.

● MULTI RIBBON Lamp

* Lights when the multi ribbon has been selected with the ribbon selector switch.
(See chapter 5: slide switch)

● ALARM Lamp

* Lights when the printer is in error.

* Lights and beeps when the ribbon reaches its end.

* Lights when printer detected paper empty or paper jam.

● SEL (Select) Switch and ON LINE Lamp

* Selects and deselects the printer: pressing the SEL switch changes the on-/off-line state alternately. The ON LINE lamp comes on when the printer enters into the Select (on-line) state.

* The printer self-test is performed by holding down the SEL switch and pressing the POWER switch. (See chapter 10.4)

* The printer has a switch which detects whether or not the top cover is open. Therefore, if the top cover is open only slightly, the ON LINE lamp will not light. If the top cover is opened during operation, the printer will cease to operate. Closing the carriage to return automatically to the previous position. Pressing the SEL switch puts the printer on-line again.

● LF (Line Feed) Switch

* Active only while the printer is in off-line state.

* Pressing the LF switch feeds paper a line at a time.

* Holding down the LF switch feeds paper continuously until it is released.

* The hexadecimal dump function is performed by holding down the LF switch and pressing the POWER switch. (See chapter 10.5)

● **TOF (Top of Form) Switch**

- * Active only while the printer is in off-line state.
- * Advances paper to the first print position when paper is not on the platen.
- * Ejects the paper when paper is on the platen.

Note

The page length is dependent on the DIP switch settings or the control code.

● **PRINT PITCH Switch and Lamp**

- * Active only while the printer is in off-line state.
- * Sets to the default value of 10 (10 characters per inch) automatically.
- * Pressing the PRINT PITCH switch changes the character pitch from 10, 12 (12 chars/in), 15 (15 chars/in) to PS (proportional spacing) this order, resulting in the corresponding lamp lit.

● **LOAD Switch and Lamp**

- * Effective only in off-line status
- * When the LOAD Switch button is pressed, change is made to SHEET (insertion), CSF (built-in Cut Sheet Feeder), FORMS (built-in tractor feeder) and DBSF (optional Dual Bin Sheet Feeder).
- * When power is turned on, the machine changes to the mode that was set with the paper handling selector switch. (see chapter 5)
- * When paper is empty or jammed, the lamp for the designated mode flickers.

● **COPY MODE Switch, COPY Lamp, and DATA FULL Lamp**

- * Enters into or exits from the COPY MODE under which the printer is ready to accept data to reprint. The COPY MODE switch is active only while the printer is in the off-line state.
- * The COPY lamp is on when the printer is in the copy mode.
- * The DATA FULL lamp lights when the data overflows to the buffer during the copy mode. (see page 30)

● **REPRINT Switch**

- * Active only while the printer is in the off-line state.
- * Reprints the data stored in the buffer during the copy mode or suspend reprinting.
- * Holding down the COPY MODE switch and pressing the REPRINT switch clears the data stored in the buffer (DATA CLEAR) and cancels reprinting. (see page 30)

5. SETTING THE DIP SWITCHES

This printer has three Dual In-Line Package (DIP) switches and one slide switch inside and each DIP switch has eight selectors respectively: DIP SW 1-1, DIP SW 2-1, etc. The DIP switches and one slide switch control the printing operation and the data communications with the computer. Because the selectors have been factory set, the printer automatically enters into the default settings. Change the settings when necessary.

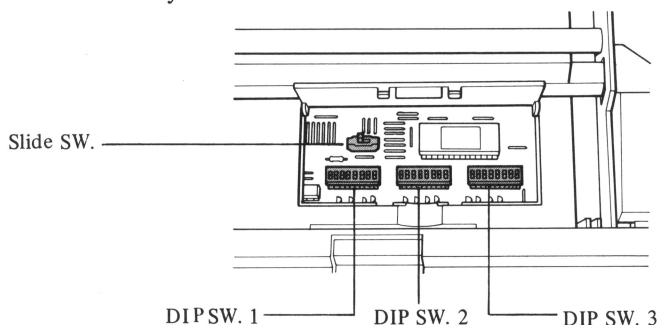

Be sure to turn off the printer before you change the DIP switch settings. Use a small pointed tool such as tweezers and a small screwdriver to change the selectors.

Table of Default Settings

Item	Setting
Print Pitch	10 (1/10 inch)
Line Pitch	1 (1/6 inch)
Print color (red/black)	Black
Ribbon (MULTI/OTHERS)	As set by slide SW
Paper Handling	As set by DIP SWs 2-6 and 2-7
Print System	Auto-backward print
Page Length	As set by DIP SWs 3-1 through 3-4
Auto Line Feed (CR/LF)	As set by DIP SW 1-6
Skip Perforation	As set by DIP SW 1-7

DIP SW 1

DIP SW	Description	ON	OFF	Factory Setting
1-1	Alternate Language		see Table 1	*
1-2	Characters			
1-3				
1-4				
1-5				
1-6	AUTO LF	Disables	Enables	ON
1-7	Skip Perforation	Disables	Enables	ON
1-8	Interface	CDCC	RS232C	ON

Note:

An asterisk (*) denotes that the DIP SW 1-1 through 1-5 are dependent on the country when the printer is shipped out.

DIP SW 2

DIP SW	Description	ON	OFF	Factory Setting
2-1*	Data Length	7 bit + 1 parity	8 bit (no parity)	ON
2-2*	Parity	Odd	Even	ON
2-3*	Baud Rate		See Table 2	ON
2-4*				ON
2-5*				ON
2-6	Paper Handling		See Table 3	ON
2-7				ON
2-8	Page End	Yes	No	OFF

Note:

As asterisk (*) denotes that the DIP SWs 2-1 through 2-5 are applicable only when the serial interface is selected.

DIP SW 3

DIP SW	Description	ON	OFF	Factory Setting
3-1	Page Length		See Table 4	ON
3-2				ON
3-3				ON
3-4				ON
3-5	Hammer Impact		See Table 5	ON
3-6				ON
3-7	Paper Tray*		See Table 6	ON
3-8				ON

Note:

An asterisk (*) denotes that DIP SWs 3-7 and 3-8 are effective only when optional dual bin sheet feeder is used.

● Slide Switch – Ribbon Selection

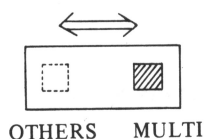

Set MULTI, to make the efficient use of multi strike ribbon.

Set OTHERS, to obtain much higher quality of printing while using multi strike ribbon or other type of ribbon (one time ribbon, fabric ribbon, and correctable ribbon).

Table 1
(see also Appendix D)

Alternate Language Characters	DIP SW				
	1-1	1-2	1-3	1-4	1-5
US ASCII	ON	ON	ON	ON	ON
German 1	ON	ON	ON	OFF	ON
UK English	ON	ON	OFF	ON	ON
UK ASCII	ON	ON	OFF	OFF	ON
UK ASCII 2	ON	OFF	ON	ON	ON
French 1	ON	OFF	ON	OFF	ON
Dutch	ON	OFF	OFF	ON	ON
Italian	ON	OFF	OFF	OFF	ON
S. Spanish	OFF	ON	ON	ON	ON
WP of American English	OFF	ON	ON	OFF	ON
Symbol	OFF	ON	OFF	ON	ON
International	OFF	ON	OFF	OFF	ON
American English	OFF	OFF	ON	ON	ON
Portuguese	OFF	OFF	ON	OFF	ON
Latin-American Spanish	OFF	OFF	OFF	ON	ON
Canadian	OFF	OFF	OFF	OFF	ON
Swiss	ON	ON	ON	ON	OFF
Norwegian & Danish	ON	ON	ON	OFF	OFF
Finnish & Swedish	ON	ON	OFF	ON	OFF
German 2**	ON	ON	OFF	OFF	OFF
French 2**	ON	OFF	ON	ON	OFF
Not Used	ON	OFF	ON	OFF	OFF
Not Used	ON	OFF	OFF	ON	OFF
Not Used	ON	OFF	OFF	OFF	OFF
8-Bit German	OFF	ON	ON	ON	OFF
8-Bit French	OFF	ON	ON	OFF	OFF
8-Bit Dutch	OFF	ON	OFF	ON	OFF
8-Bit S. Spanish	OFF	ON	OFF	OFF	OFF
8-Bit Swiss	OFF	OFF	ON	ON	OFF
8-Bit Norwegian & Danish	OFF	OFF	ON	OFF	OFF
8-Bit Finnish & Swedish	OFF	OFF	OFF	ON	OFF
Combination**	OFF	OFF	OFF	OFF	OFF

Note 1:
Asterisks (**) denote that the combination daisy wheel should be used to print characters concerned.

Table 4

Page Length	DIP SW			
	3-1	3-2	3-3	3-4
11"	ON	ON	ON	ON
3"	ON	ON	ON	OFF
3.5"	ON	ON	OFF	ON
4"	ON	ON	OFF	OFF
5"	ON	OFF	ON	ON
5.5"	ON	OFF	ON	OFF
6"	ON	OFF	OFF	ON
7"	ON	OFF	OFF	OFF
8"	OFF	ON	ON	ON
8.5"	OFF	ON	ON	OFF
9"	OFF	ON	OFF	ON
10"	OFF	ON	OFF	OFF
11-2/3"	OFF	OFF	ON	ON
12"	OFF	OFF	ON	OFF
14"	OFF	OFF	OFF	ON
17"	OFF	OFF	OFF	OFF

Table 2

Baud Rate	DIP SW		
	2-3	2-4	2-5
9600	ON	ON	ON
4800	ON	ON	OFF
2400	ON	OFF	ON
1200	ON	OFF	OFF
600	OFF	ON	ON
300	OFF	ON	OFF
150	OFF	OFF	ON
110	OFF	OFF	OFF

Table 3

Paper Handling	DIP SW	
	2-6	2-7
SHEET	ON	ON
FORMS	OFF	ON
CSF	ON	OFF
DBSF	OFF	OFF

Table 5

Hammer Impact	DIP SW	
	3-5	3-6
L	OFF	ON
M	ON	ON
H	OFF	OFF

Table 6

Paper Tray (DBSF)	DIP SW	
	3-7	3-8
Tray 1 (Upper)	ON	ON
Tray 2 (Lower)	OFF	ON
Envelope	OFF	OFF

- **Alternate Language Characters – DIP SWs 1-1 through 1-5**

Choose the language characters corresponding to the daisy wheel being used. (see *Table 1 Alternate Language Characters.*)

- **Auto LF – DIP SW 1-6**

With this switch set to ON, only a Carriage Return (CR) code is sent, so that the printer prints data and moves the carriage, but does not feed a line. When a Carriage Return (CR) code is sent with the switch set to OFF, the printer prints data, moves the carriage, and feeds a line.

- **Skip Perforation – DIP SW 1-7**

If this function is enabled (switched to OFF), you can automatically skip over a perforation of fan-fold paper to advance as far as the print start position on the next page. If disabled (switched to ON), no skipping is performed.

- **Interface-DIP SW 1-8**

Select a serial or parallel interface.

- **Data Length – DIP SW 2-1**

If you use a serial interface, choose 7- or 8-bit data to communicate with your computer. The data length is dependent on the setting of your computer or application software.

If this switch is set to OFF, the 8th bit of a byte data is ignored. When you use any 8-bit daisy wheel with the serial interface selected, be sure to set the switch to ON to accept the 8th bit.

A parity bit is added when the 7-bit data mode is selected and no parity bit when the 8-bit data mode.

(see *Table 1 Alternate Language Characters.*)

- **Parity – DIP SW 2-2**

Select parity, even or odd, to check data. This setting is applied only when you use a serial interface. The setting of this switch is valid only when the DIP SW 2-1 is set to OFF.

- **Baud Rate – DIP SWs 2-3 through 2-5**

The baud rate is a data signalling rate or a standard unit of data transmission speed (bit/second). It is necessary to match the settings for serial communications between printers and computers.

- **Paper Handling Mode – DIP SW 2-6, 2-7**

Select the default setting of Paper Handling tool.

- **Page End-DIP SW 2-8**

With this switch set to ON, the end of each page is detected to feed next page. When you use Word Processing software, please set to OFF.

- **Page Length – DIP SWs 3-1 through 3-4**

Select Your page length according to the paper to be used.

- **Hammer Impact – DIP SW 3-5, 3-6**

Adjust the Hammer impression.

- **Paper Tray Selection of DBSF – DIP SW 3-7, 3-8**

Desides the type of paper tray to be selected when optional DBSF mode is used.

6. REPLACING THE RIBBON CASSETTE

Four types of ribbon cassettes can be used for this printer: correctable carbon, multi-strike carbon, one-time carbon, and fabric.

Please refer to P.8 for ribbon mode setting.

Step 1

Open the top cover.

Step 2

Move the carriage to the center.

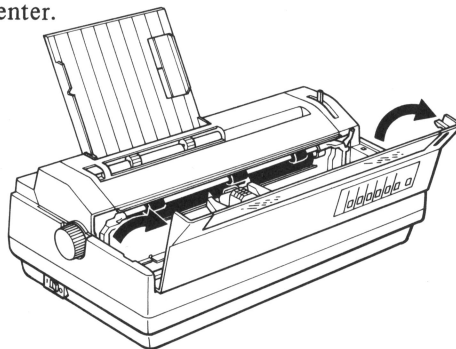

Step 3

Holding the ribbon cassette with both hands, tilt the ribbon out of the daisy wheel. Then remove it.

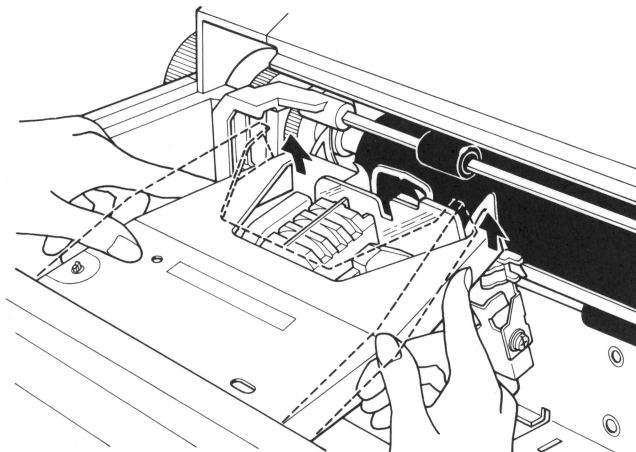

Step 4

Turn the ribbon feed knob on replacement cassette to remove any slack from the ribbon.

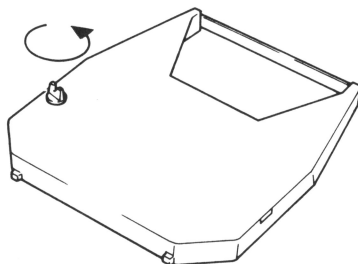

Step 5

First insert the tabs located on the bottom of the cassette into the corresponding holes of the carriage. Then set the ribbon cassette so that the ribbon falls between the ribbon guides.

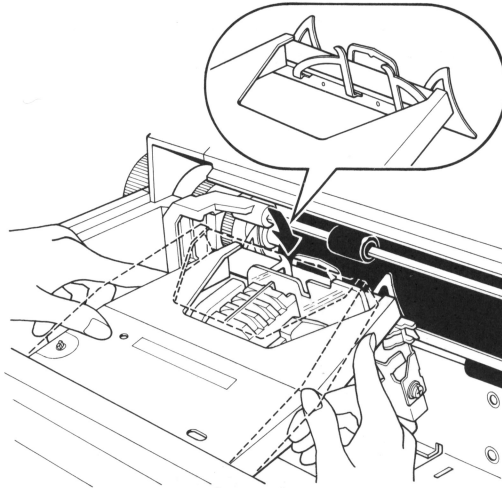

Step 6

Snap the ribbon cassette onto the carriage.

Step 7

Turn the ribbon feed knob again to remove any slack from the ribbon.

Step 8

Close the top cover.

7. INSTALLING THE COLOR RIBBON SPOOL

With the printer's versatile printing mechanism, you can print characters in another color for added emphasis. The second color ribbon spool is completely separate from the black ribbon cassette.

Step 1

Open the top cover.

Step 2

Move the carriage to the center.

Step 3

Holding the ribbon cassette with both hands, tilt the ribbon out of the daisy wheel. Then lift up and remove it.

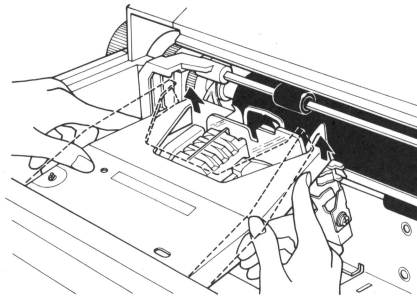

Step 4

Hold each spool by hand, making sure that the ink side of the ribbon faces the platen and then let the ribbon through the guides. First put the left spool into place and next the right spool.

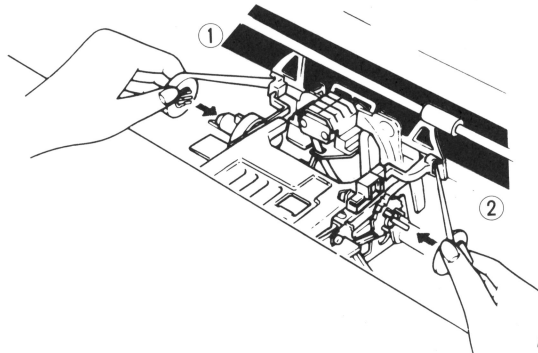

Step 5

Wind the right spool to take up any slack in color ribbon.

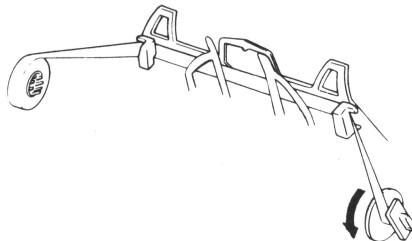

Step 6

Now put the black ribbon cassette back in place and close the top cover.

8. CHANGING THE DAISY WHEEL

A daisywheel cassette slips in and out easily and prevents ink from getting on your fingers. Because they are in a cassette, the printing elements are protected against damage. You need not remove the ribbon cassette to change the daisy wheel cassette. Character pitch is available in 10, 12, 15 characters per inch and proportional spacing. Printing pitch can be changed by pressing the PITCH switch on the front control panel.

Step 1

Open the top cover.

Step 2

Pull the motor lock knob toward you.

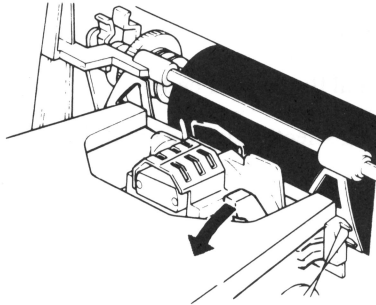

Step 3

Remove the daisy wheel cassette by grasping the tab provided on the right corner and pulling it straight up.

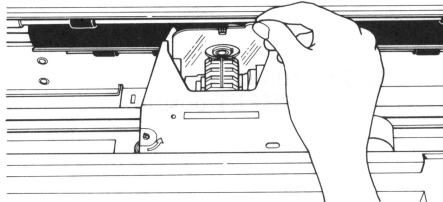
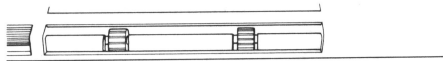

Step 4

Insert a new daisy wheel cassette by holding the tab provided on the right corner and slide it in place until it securely reaches the bottom.

Note

Check to see the cassette is not reversed.

Step 5

Push the motor lock knob toward the platen until it clicks. The cassette should be locked properly in place.

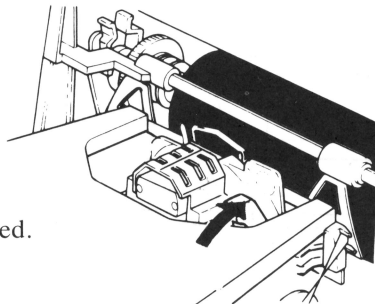

Note

Please make sure that the motor lock knob is fully latched.

Step 6

Close the top cover.

9. LOADING PAPER

9.1 Paper Selection

Set the LOAD switch on the Panel switch to correspond to the type of paper used. For mode selection, refer to the chart below:

Mode/Load SW	Operation	CSF Button	Paper Release Lever
SHEET	Manual Insertion	Raised	SHEET
CSF	Built In Sheet Feeder	Lowered	SHEET
FORMS	Built In Tractor Feeder	Raised	FORMS
DBSF	Optional Dual Bin Sheet Feeder	-	SHEET

When power is ON, default setting selection is made with DIP Switch (see page 7).

9.2 SHEET Mode

Specifications

Paper Width	max. 420mm 16.6"
Paper Thickness	Less than 0.35mm
Copy Capacity	Original + 4 copies

Step 1

Remove paper tray.

Step 2

Make sure **CSF button** is in the raised position.

Make sure the Paper release lever is in the **SHEET** position.

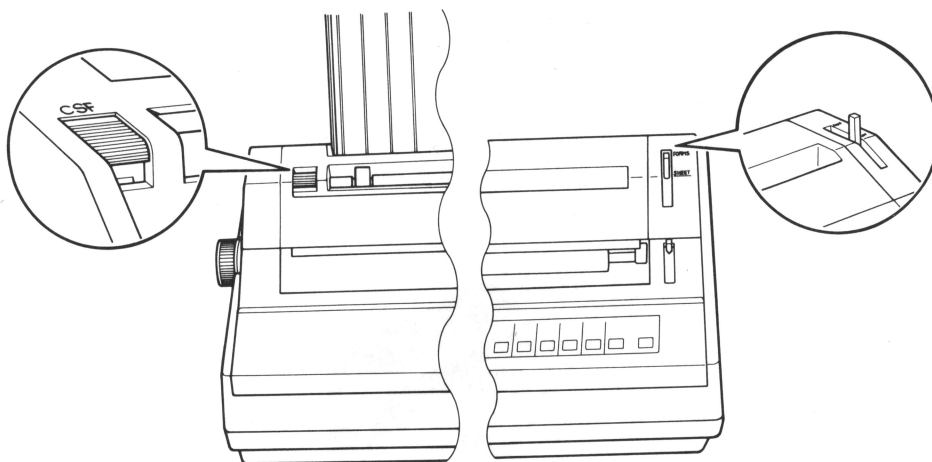

Step 3

Press the SEL switch to take the printer off-line.

Step 4

Press the LOAD switch to select SHEET mode.

Step 5

Align a single sheet of paper and insert it until it stops.

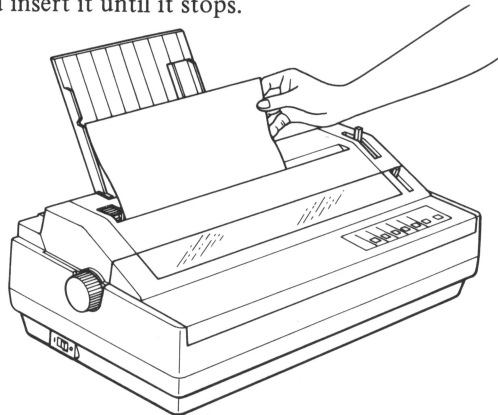

Step 6

Pressing the TOF switch automatically feeds the paper. When necessary, turn the platen knob to feed the paper manually.

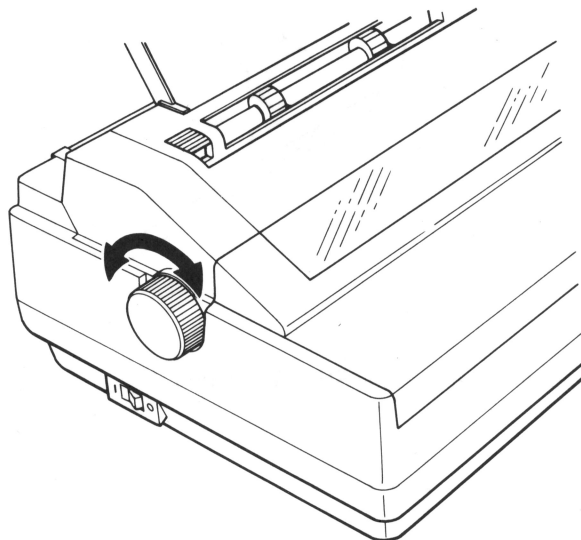

9.3 CSF Mode

Specifications of Cut Sheet Feeder

Paper width	A4 size 210mm x 297mm (8-1/4" x 11-1/3") Letter size 215.9mm x 279.4mm (8-1/2" x 11")
Paper capacity	Max. 30 sheets (16 lbs.) [within the scale of paper guide]

Paper Specifications

Paper Weight	16 – 24 lbs. (60 – 90 g/m ²) (51.6 – 77 kg)
Paper Smoothness	75 – 250 Sheffield (80 – 10 bekk)
Storage Environment	
Temperature	50°F – 104°F (10°C – 40°C)
Relative humidity	45 – 55%

● Preparation

Step 1

Press the **CSF** button to the lowered position.

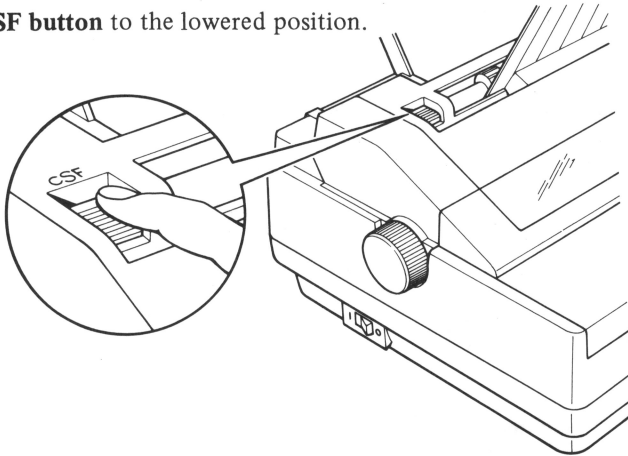

Step 2

Make sure the paper release lever is in the **SHEET** position.

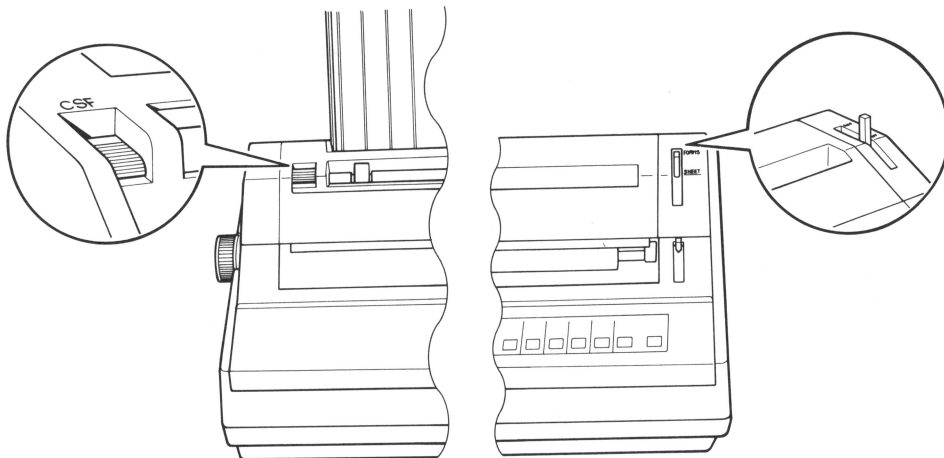

● **Setting a Stack of Paper**

Step 1

Move the paper guide to the rightmost position.

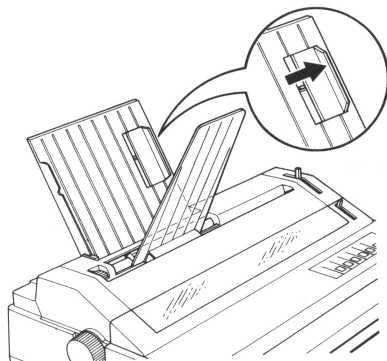

Step 2

Set a stack of paper in the paper stacker straight and neatly by first aligning the left side of the stack flush and then moving the paper guide to the right side.

Note

Take care not to overset paper, exceeding the cut on the left side.

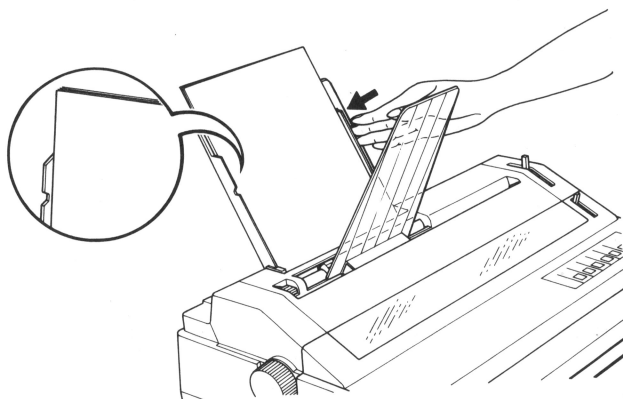

● Operating the Cut Sheet Feeder by Control Switch

Step 1

With the power switch turned on, press the SEL switch to take the printer off-line, the ON LINE lamp will go out.

Press the LOAD switch to select CSF mode.

Step 2

Press the TOF switch to load the paper automatically.

Note

The paper stops when its top edge appears; the paper bail is still open.

Step 3

Now a sheet is loaded and ready for printing. After changing to the on-line state, print as required.

Note

After the paper is fed a few lines, the paper bail automatically closes.

Step 4

After printing, take the printer off-line again and press the TOF switch, so that the printed paper is ejected to the paper tray. Press the TOF switch again to load the next sheet.

● Operating the Cut Sheet Feeder by Control Code

Step 1

Turn the power switch ON and press the SEL switch to take the printer off-line.

Press the LOAD switch to select CSF mode.

Press the SEL switch to take the printer on-line.

Step 2

Sending a Form Feed (FF) code <hex: 0C> in on-line status load the paper automatically.

Note

The paper stops when its top edge appears; the paper bail is still open.

Step 3

Now a sheet is loaded ready for printing. Print as required.

Note

After the paper is fed a few lines, the paper bail automatically closes.

Step 4

Another FF code after printing ejects the printed paper to the paper tray, and automatically loads the next paper to the printer in case the data is remained in the buffer.

Note

To eject the paper remaining in the printer, without loading the next, send an ESC EM R [hex: 1B 19 52].

● Limitations

1. Paper which does not accord with the specifications cannot be guaranteed to feed with the cut sheet feeder successfully and it is recommended that such paper should be inserted manually.
2. We can not guarantee the operation of the last 2 sheets of the paper tray.

● Recommendations

1. Paper should be removed from the auto cut sheet feeder overnight and placed in the normal paper storage.
2. If the paper to be used is warped, correct the warp and insert the paper with the bowed side up.
3. Before setting paper into the paper stacker, riffle the stack of paper.
4. Maintain the platen in good condition by cleaning it regularly with alcohol.
5. Do not pull paper tray and paper stacker forward forcefully.
6. When the paper is jammed, remove the paper stacker, the gear cover, and the CSF attachment cover and clear the paper.

9.4 FORMS Mode

Specifications

Paper Width	4.25" – 15"
Paper Thickness	Less than 0.35mm
Copy Capacity	Original + 4 copies

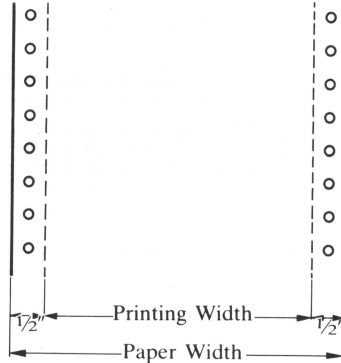

● Paper setting

Step 1

Remove paper stacker and paper tray.

Step 2

Set the FORMS Ejection Guide.

Step 3

Open tractor cover.

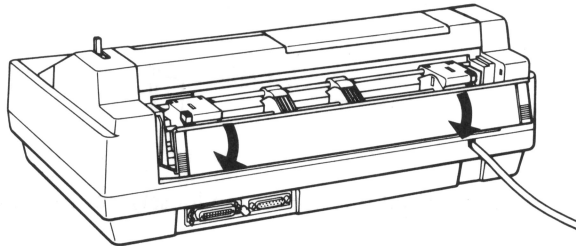

Step 4

Insert continuous forms through the window of tractor cover.

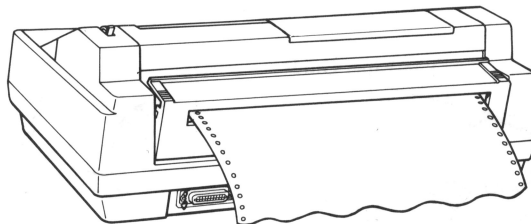

Step 5

The right and left pin wheel guides can be moved by holding down the tractor lock button. While moving the guides, adjust their positions according to the width of your paper.

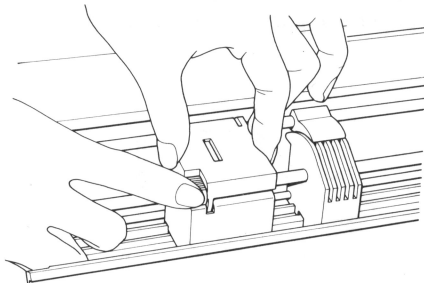

Step 6

Move two paper guides and sub-paper guides and locate them at equal intervals to the width of paper; otherwise, the printer may jam up.

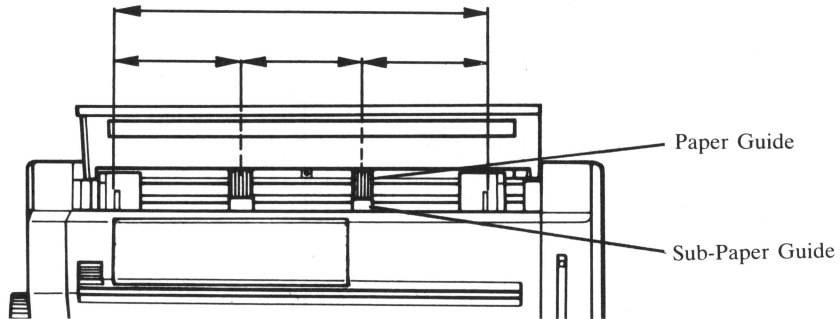

Step 7

Open the pin wheel doors and set continuous forms so that the pins fit into the holes of paper.

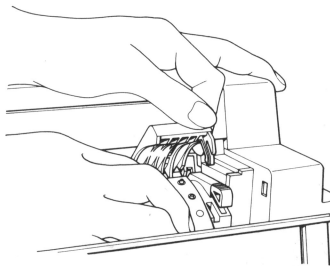

Note 1

Make sure that the paper is not skewed and it is not set too loosely nor too tensely.

Note 2

Take care not to make the paper reach the platen by turning the platen knob. If it reaches the platen, the automatic paper insertion does not function.

Note 3

Be sure to set the paper so that it goes through between the paper guides and the sub-paper guides.

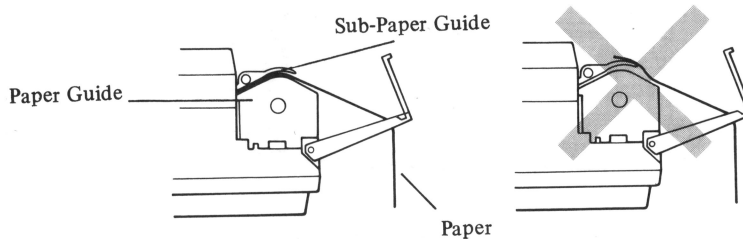

Note 4

Feed paper manually until the paper top goes under the sub-paper guide shaft.

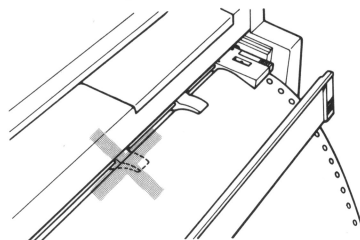

• **Loading Continuous Forms**

Step 1

Turn on the POWER switch.

Step 2

Press the LOAD switch and select the FORMS position: the FORMS lamp comes on.

Step 3

Set paper release lever to the FORMS position. Make sure CSF button is in the raised position.

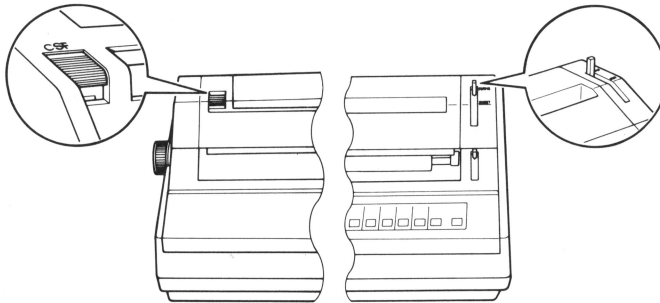

Step 4

Change the Pressure Control Lever according to the number of copies when the continuous forms for multiple parts are to be used.



Step 5

Press the TOF switch under the offline state. Then the paper bail automatically opens to load the continuous forms to the specified position.

Note

After loading continuous forms, paper should be pulled upwards from the front of the platen to remove any slack between the tractor wheels and platen.

Note for Trouble Free Printing

A straight paper supply is important. Locate the printer and the paper box as shown in the following figures.

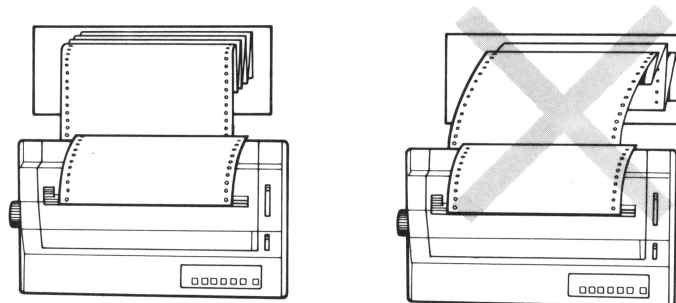

- **Paper Parking**

Cut sheet or sheet feeder can be used without detaching continuous paper from the tractor pin.

Step 1

Separate finished paper by tearing along the perforated portion.

Step 2

Press SEL switch to take the printer off-line.

Step 3

Press the LF switch with LOAD switch depressed to retire the continuous paper.

Step 4

When paper comes to retired position, buzzer sounds.

Note

The intermittent alarm gradually quickens and changes into a continuous sound. Stop the escape action before the alarm changes to a continuous sound.

Step 5

Set paper release lever to the SHEET position.
Follow the steps of desired paper handling mode.

9.5 DBSF Mode

(Using An Optional Dual Bin Sheet Feeder)

Specifications of Cut Sheet Feeder

Paper sizes	
widths, both bins:	7" to 14"
upper bin lengths:	9-3/4" to 14"
lower bin lengths:	7" to 14"
Capacity, each bin:	125 sheets of 20 lb. paper
Envelope weights:	20 to 24 lb. paper
Envelope capacity:	40 (20 lb.) envelopes
Envelope sizes	35 (24 lb.) envelopes
widths:	8" to 9-1/2"
lengths:	4-1/8" to 5"
Output bin capacity:	175 sheets

Paper Specifications

Paper Weight	16 – 24 lbs. (60 – 90 g/m ²) (51.6 – 77 kg)
Paper Smoothness	75 – 250 Sheffield (80 – 10 bekk)

• Installation

Step 1

Make sure that the printer is turned off.

Step 2

Remove paper tray and paper stacker.

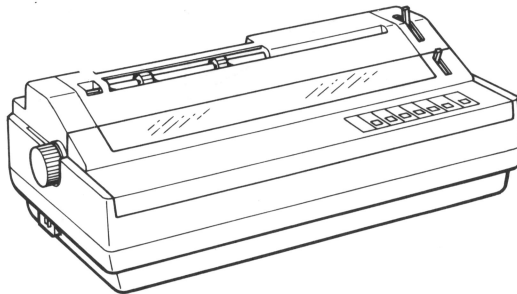

Step 3

Open the top cover.

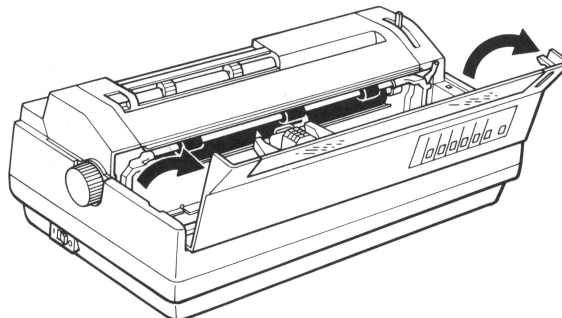

Step 4

Take out gear cover by pulling upward.

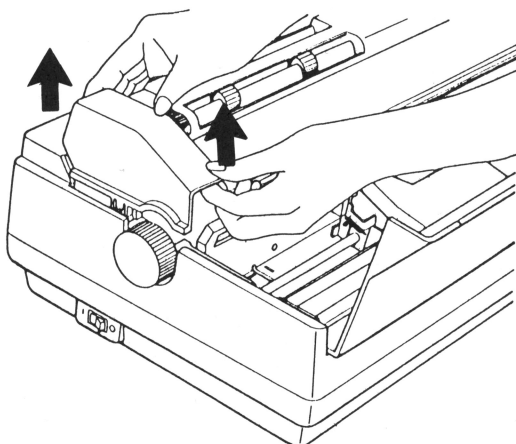

Step 5

Remove the CSF attachment cover.

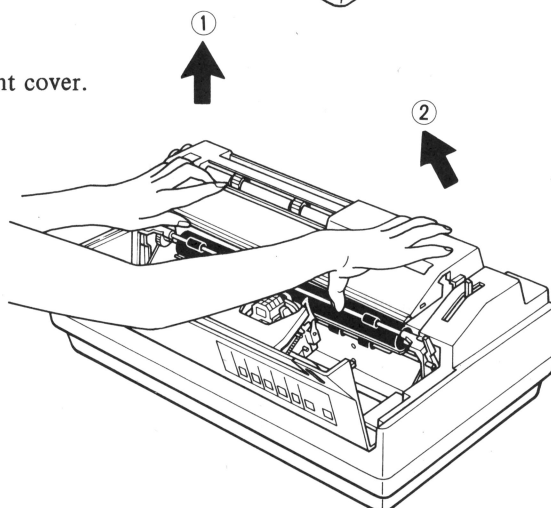

Step 6

Hold the dual bin sheet feeder unit with both hands. Install the unit, tilting it toward you and snapping down its hooks onto the platen shaft on both sides.

Note 1

Make sure that the left hook fits into the plastic part of the shaft and the gears engage with each other.

Note 2

Remove the output bin of sheet feeder in advance.

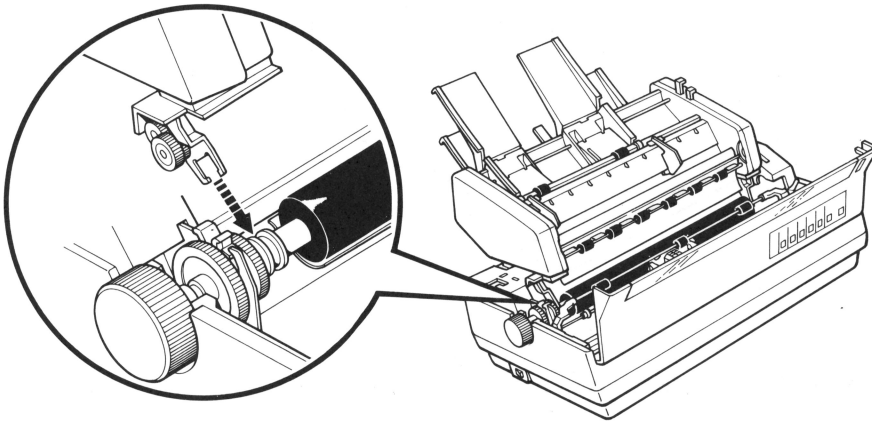

Step 7

Replace the gear cover and close the top cover.

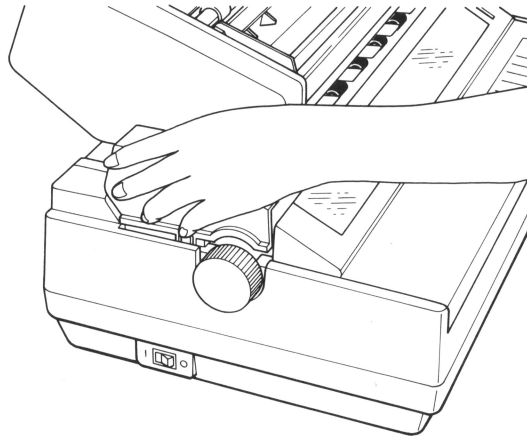

Step 8

Set the out put bin of sheet feeder.

Make sure paper release lever is in the **SHEET** position.

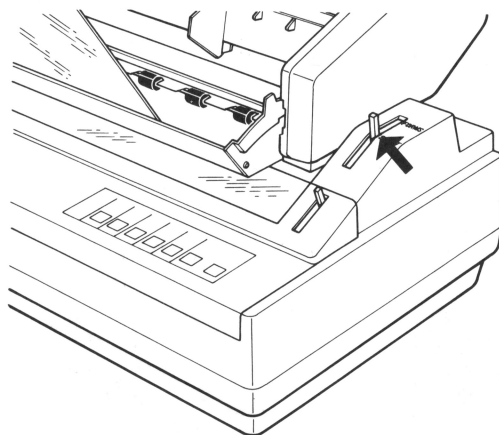

Note

DIN connector for Dual bin sheet feeder need not be connected.

● **Operating the dual bin sheet feeder**

Step 1

With the power switch turned on, press the SEL switch to take the printer off-line, the ON LINE lamp will go out.

Press the LOAD switch to select DBSF mode.

Step 2

Press the TOF switch to load the paper automatically from the designated paper tray by DIP switch. (See page 9)

Note

The paper stops when its top edge appears; the paper bail is still open.

Step 3

Now a sheet is loaded and ready for printing. After changing to the on-line state, print as required.

Note

After the paper is fed a few lines, the paper bail automatically closes.

Step 4

After printing, take the printer off-line again and press the TOF switch, so that the printed paper is ejected to the stacker. Press the TOF switch again to load the next sheet.

You can also select paper tray by software.

Please refer to page 39.

10. VERSATILE FUNCTIONS

10.1 Direct Printing

With the direct printing function, you can use the printer like a typewriter by keying in data from the keyboard of a computer. Data stored in the buffer are automatically printed when you stop typing. To activate the direct printing function, a short BASIC program should be used. When you use, for example, an IBM Personal Computer through Centronics interface, a program is as follows:

```
10 A$ = INKEY$
20 IF A$ = "" THEN GOTO 10
30 LPRINT A$;
40 GOTO 10
50 END
```

10.2 Copy Function

Once data are loaded to the printer in the copy mode, you can reprint the same text as many times as need with the simple operation of the panel switch.

• How to Load Data

Step 1

Press the COPY MODE switch under the off-line state: the COPY lamp comes on.

Note

The printer ignores the switch operation and beeps when data remains in the buffer.

Step 2

Press the SEL switch and load data from the computer, resulting in printing.

Note

The DATA FULL lamp goes on when data sent exceeds the capacity of the buffer

• How to Reprint

Step 1

After data are printed, press the SEL switch again to take the printer off-line.

Step 2

Press the REPRINT switch to print the data loaded in the buffer.

Note 1

When the DATA FULL lamp goes on, the data which exceed the buffer capacity can not be printed.

Note 2

To suspend printing, press the REPRINT switch.

Note 3

In FORMS, CSF or DBSF Mode, the printer automatically returns to the initial data and resumes printing after approximately 5 seconds' pause.

• How to Exit from the Copy Mode

Step 1

Press the COPY MODE switch, the no COPY lamp will light.

Step 2

Press the SEL switch.

10.3 Buffer Clear

To cancel printing after data have been loaded, hold down the COPY MODE switch under the off-line state and press the REPRINT switch. When buffer is cleared, carriage returns to the left margin. You do not need to turn off the printer. This function is also available when you are using the copy mode function.

10.4 Self-Test Function

The self-test function enables you to test the printer without connecting to your computer.

Step 1

Set paper to the printer.

Step 2

While holding down the SEL switch, turn on the printer. The printer will start the self test.

Step 3

To stop the self-test, turn off the printer.

```
!"#$%&'()*+,-./0123456789:;<=>? PQRSTUVWXYZ[±]2 °abcde
!"#$%&'()*+,-./0123456789:;<=>? PQRSTUVWXYZ[±]2 °abcdef
!"#$%&'()*+,-./0123456789:;<=>? PQRSTUVWXYZ[±]2 °abcdefg
#$%&'()*+,-./0123456789:;<=>?@ QRSTUVWXYZ[±]2 °abcdefgh
#$%&'()*+,-./0123456789:;<=>?@A RSTUVWXYZ[±]2 °abcdefghi
%&'()*+,-./0123456789:;<=>?@AB STUVWXYZ[±]2 °abcdefghij
&'()*+,-./0123456789:;<=>?@ABC TUVWXYZ[±]2 °abcdefghijkl
'()*+,-./0123456789:;<=>?@ABCDI VWXYZ[±]2 °abcdefghijkl
()*+,-./0123456789:;<=>?@ABCDEI WXYZ[±]2 °abcdefghijklm
)*+,-./0123456789:;<=>?@ABCDEF JXYZ[±]2 °abcdefghijklmn
*+,-./0123456789:;<=>?@ABCDEFK XYZ[±]2 °abcdefghijklmno
+,-./0123456789:;<=>?@ABCDEFK LXYZ[±]2 °abcdefghijklmnop
,-./0123456789:;<=>?@ABCDEFK MXYZ[±]2 °abcdefghijklmnopq
```

10.5 Hex Dump Function

The hexadecimal dump function enables you to check the send data in hex numbers.

Step 1

Set paper in the printer.

Step 2

While holding down the LF switch, turn on the printer. The printer prints the hexadecimal code of the input data.

Step 3

To stop the hex dump printing, turn off the printer by pressing the POWER switch.

```
DAISY WHEEL PRINTER
DAISY WHEEL PRINTER
```



```
44 41 49 53 59 20 57 48 45 45
4C 20 50 52 49 4E 54 45 52 0D
0A 1B 45 0D 0A 44 41 49 53 59
20 57 48 45 45 4C 20 50 52 49
4E 54 45 52 0D 0A 1B 52 0D 0A
```

10.6 Detection Functions

The following detection functions are provided to ensure the proper operation of the printer.

● Top Cover Open

This function prevents the printer from being operated when the top cover is open or not fully closed.

1. When the top cover is opened, the printer suspends the printing operation and returns to the off-line state.
2. When the top cover is closed, the carriage returns to its former printing position automatically.
3. When the SEL switch is pressed, the printer enters the on-line state and resumes printing.

● Paper Empty (PE)

When "paper empty" is detected, printing ceases. At this time the SELECT lamp goes out and the ALARM lamp goes on, and the currently lit LOAD lamp flickers. If the paper is set in place with the TOF switch, the ALARM lamp will be turned off and the flickering LOAD lamp will go on. Press down the SELECT switch to turn on the SELECT lamp and restart printing.

Note

Even after the paper empty is detected with the ALARM lamp lit, an additional line can be printed on the same page by pressing the SEL switch. (SHEET, FORMS only)
In DBSF and CSF modes, when a PE is detected before the end of a page, the page is ejected and the next page inserted.

● Ribbon End (RE)

1. When the ribbon comes to its end, the printer enters the off-line state, the ALARM lamp lights, and the buzzer sounds.
2. When the ribbon cassette is removed, the ALARM lamp goes off and the buzzer sound stops.
3. Replace the old ribbon cassette with a new one.
4. Press the SEL switch to resume printing.

11. CONTROL CODES

ASCII Code

You can create a variety of documents through the use of your versatile application software. To get more out of your printer, simply send control and print instructions from your computer.

Computers and printers do not communicate in the same language as we do. They communicate by interchanging alphanumerical characters. As they only “understand” binary numbers, alphabetical characters and decimal numbers are all coded in binary notation. Control and print instructions also must be sent as codes. Such codes are created in many ways by many manufacturers, often creating confusion.

To avoid such confusion, the American Standard Code for Information Interchange (ASCII) has been established. The printer is one of many information devices that utilizes the ASCII to communicate with the computer.

Each ASCII code consists basically of 8 bits. However, only 7 bit ASCII codes are usually used. The most significant (or first) digit of the binary number can usually be omitted for convenience. In ASCII, the binary number “(0) 1000001” corresponds to the alphabetical character “A” (upper case). The ASCII codes have upper and lower case letters, numbers, punctuation marks, symbols and control codes. Each of them are represented by a binary number which computers and printers understand.

There are two types of ASCII control codes: control characters and control sequences. Some instructions – for example, the instructions for printing characters and controlling the print head motion – are sent by using the special control character “Escape” followed by other control characters and numbers. These are called “Escape Sequences” (ESC). The ESC sequences enhance the versatility of a printer.

Programming:

To send control codes from the computer to the printer, you have to program in any computer language such as BASIC or Pascal. Because this manual is not an introductory handbook for computer languages and programming, it just covers technical information regarding the control codes. If you are not familiar with programming, it is difficult to understand these sections. Even if you don't completely understand them, you must learn to use control codes with your printer. If you are a novice programmer, controlling the printer is good practice for you. Please review the following descriptions to learn how your printer works. If you are already familiar with control codes, the following section may serve as a reference.

Note

All control codes override DIP switch settings.

Control Characters

- **Bell – BEL Hex: 07**

Beeps for approximately 2 seconds

- **Backspace – BS Hex: 08**

Moves the carriage backward one character (1/60" in the graphics mode)

- **Horizontal Tab – HT Hex: 09**

Advances the carriage up to the next horizontal tab (HT) stop. This code is not effective when HT stop has not been set for that HT code.

- **Line Feed – LF Hex: 0A**

One line after one line of data are printed out. The carriage does not return to the left margin.

● **Vertical Tab – VT Hex: 0B**

Advances the carriage up to the next vertical tab (VT) stop after data in the buffer are printed out. This code is not effective when VT stop has not been set for that VT code.

● **Form Feed – FF Hex: 0C**

Feeds paper after one line of data printed out.

1. In SHEET and FORMS Modes

When paper is already set in place, use the dip switch or the control code from the outside to feed the paper that remains when the length of actual use is subtracted from the set page length.

When paper is not already set in place, conduct automatic insertion from the top of paper.

2. In CSF and DBSF Modes

When paper is already set in place, discharge paper to the stacker and, if there is any data remaining, conduct automatic insertion from the top of paper.

When paper is not already set in place, conduct automatic insertion from the top of paper.

● **Carriage Return – CR Hex: 0D**

1. Prints one line of data in the buffer

2. Then feeds one line if so set by the DIP switch or the ESC sequence. (This is effective even when only a CR code is entered because a CR code is almost followed by a LF code.)

3. Clears the shadow, double-strike print and graphics modes.

● **Device Control 1 – DC1 Hex: 11**

Selects the printer: the printer enters into the on-line state. Only this code is accepted if the printer is in the off-line state.

● **Device Control 3 – DC3 Hex: 13**

Deselects the printer: the printer goes out of the on-line state and enters into the off-line state.

● **Cancel – CAN Hex: 18**

Delete – DEL Hex: 7F

Clears the input print data from the buffer up to the previous CR, LF, VT, or FF code.

● **Escape – ESC Hex: 1B**

Expansion code used when followed by other control characters or numbers.

– see the following sections.

● **Space – SP Hex: 20**

Moves the carriage by the values of current HMI.

In PS mode, depends on HMI value.

Setting Format

● **Character Pitch (HMI) – Set: ESC US *n***

Reset to the control panel setting – ESC S

$$\text{HMI} = (n - 1) \times 1/120$$

n is any value from 1 to 126 except a NUL code and a DEL code. The character pitch can be set in 1/120" increment. When set, the carriage moves by the value of HMI each time a character or a symbol is printed. An ESC S code restores the character pitch to the control panel setting.

● **Line Pitch (VMI) – Set: ESC RS *n***

Reset to the control panel setting – ESC S

$$\text{VMI} = (n - 1) \times 1/48$$

n is any value from 1 to 126 except a NUL code and a DEL code. The line pitch can be set in 1/48" increment. When set, the form is fed by the value of VMI on codes such as LF, Reverse LF, and half-VMI for superscripts and subscripts. An ESC S code restores the line pitch to the default setting.

- **Page Length** – Set: ESC FF *n*
Reset to the DIP switch setting – ESC S
Page length = *n* × VMI

n is from 1 to 126 except a NUL code and a DEL code. The page length is stored in the memory as the absolute position measured with reference to the top of the page. Therefore, if you change the VMI, the number of lines per page also changes. An ESC S code restores the page length to the DIP switch setting. The page length of 3 inches or less can not be set.

When DBSF mode is used, the page length at each tray can be set respectively.

Page Length Setting Range in DBSF Mode.

Page length setting ranges for each paper tray are shown in the following chart:

TRAY	Page Length	MINIMUM	DEFAULT	MAXIMUM
TRAY 1		3"	As set by DIP SW 3-1 through 3-4	17"
TRAY 2		3"		17"
TRAY 3 (ENVELOPE TRAY)		3"		17"

Setting commands for page lengths outside these ranges are ineffective. _

- **Left Margin** – Set: ESC 9

Defines the current position as the left margin. It is possible to move the carriage outside the left margin by an Absolute HT code or a BS code (in order to reset the left margin). This code is ignored if the current position is outside the right margin.

- **Right Margin** – Set: ESC 0

Defines the current position as the right margin. It is possible to move the carriage outside the right margin by an Absolute HT (to reset the right margin). This code is ignored if the position is outside the left margin.

- **HT Stop** – Set: ESC 1

Clear a HT stop of current position: ESC 8
Clear all HT stops: ESC 2

An ESC 1 code sets a horizontal tab (HT) stop at the current position. (Up to 20 HT stops can be set.) An ESC 8 code clears the HT stop which has been set at the current position and an ESC 2 code clears all preset HT stops as well as all preset VT stops.

- **VT Stop** – Set: ESC –

Clear all VT stops: ESC 2

An ESC – code sets a vertical tab (VT) stop at the current position. (Up to 10 VT stops can be set.) An ESC 2 code clears all VT stops as well as all HT stops: you cannot clear the single VT stop of the current position.

- **Top Margin** – Set: ESC T
Clear: ESC C
by setting the page length
by resetting the printer

An ESC T code defines the top margin at the current vertical position. When the form has come to the bottom margin or the top of the page by a LF code, it is fed further over the top margin automatically. It is possible to feed the form outside the top margin by codes such as Reverse LF, or Absolute VT (to reset the top margin).

The top margin can be cleared when you change the page length, reset the printer, or send an ESC C code. But, except by the ESC C, the top margin is reset to 1 inch if the skip perforation function has been set. The top margin setting is ignored if the position is outside the bottom margin.

When DBSF mode is used, the top margin at each tray can be set respectively.

- **Bottom Margin** – Set: ESC L
Clear: ESC C
by setting the page length
by resetting the printer

An ESC L defines the bottom margin boundary at the current vertical position. If the form has reached the bottom margin by codes such as LF, Auto LF, or Half-LF, it is fed further over the bottom margin or to the top of form position on the next page automatically. It is possible to feed the form outside the bottom margin by codes such as Absolute VT.

The bottom margin can be cleared when you change the page length, reset the printer, or send an ESC C code. But, except by the ESC C, the bottom margin is reset to 1 inch if the skip perforation function has been set. The bottom margin setting is ignored if the position is outside the top margin.

When DBSF mode is used, the bottom margin at each tray can be set respectively.

- **Absolute HT** – Set: ESC HT *n*
Distance to move = $(n - 1) \times \text{HMI}$

n is any value from 1 to 126 except a NUL code and a DEL code. The distance unit is the current HMI value $\times 1/120''$.

Sending this code moves the carriage directly to the specified position from the leftmost side of the platen: the located position is not stored as an HT stop in the memory. (Margins are ignored.) This code is ignored if the specified position is outside the platen width.

- **Absolute VT** – Set: ESC VT *n*
Distance to move = $(n - 1) \times \text{VMI}$

n is any value from 1 to 126 except a NUL code and a DEL code. The distance unit is the current VMI value $\times 1/48''$.

Sending this code moves the carriage directly to the specified line from the top of the page: the located position is not stored as a VT stop in the memory. This code is ignored if the specified position is outside the page.

It is possible to set positions outside the top and bottom margins. (Margins are ignored.)

- **Reverse LF** – Set: ESC LF

Feeds paper in reverse by the current VMI value.

When using CSF and FORMS modes, a reverse feed of cumulative 1/6" or less is possible; when using SHEET and DBSF modes, reverse feed is possible.

- **Half-LF** – Set: ESC U

Feeds paper by half the current VMI value. Any remainder is ignored.

- **Reverse Half-LF** – Set: ESC D

Feeds paper in reverse by half the current VMI value. Any remainder is ignored.

- **Auto Backward Print** – Set: ESC /
Clear: ESC \

Sets the logic seeking bidirectional printing. Auto backward print is a default setting at power on or it is selected when the mode has been changed.

- **Forward Print** – Set: ESC 5

Sets unidirectional printing from left to right (as in tabulation).

- **Backward Print** – Set: ESC 6

Sets unidirectional printing from right to left.

- **Auto LF** – Set: ESC "
Clear: ESC #

When Auto LF is set, the printer executes a carriage return (CR) and a line feed (LF), responding to a CR code.

- **BS by 1/120"** – Set: ESC BS

Moves the carriage 1/120" in reverse.

Selecting Versatile Print Functions

- **Proportional Spacing (PS)** – Set: ESC P
Clear: ESC Q
Reset the control panel setting: ESC S

When set, the HMI value is 10 (10 CPI, $12 \times 1/120''$). When cleared, the current HMI value is restored. In the PS mode, the HMI is effective only for Absolute HT and spaces.

- **Red print** – Set: ESC A

After setting, red ribbon is selected to print red characters.

- **Black print** – Set: ESC B

After setting, black ribbon is selected to print black characters.

- **Auto Underline** – Set: ESC E
Clear: ESC R or ESC X

When set, characters and symbols are all underlined.

- **Auto Strike-Out** – Set: ESC H
Clear: ESC I or ESC X

When set, characters and symbols are overprinted with hyphens.

- **Shadow Print** – Set: ESC W
Clear: CR, ESC &, or ESC X

Characters and symbols are all printed out twice offset with a $1/120''$ carriage movement between strokes. The shadow print mode is overruled by the double-strike print mode if set. In the shadow print mode, printing is executed only from left to right.

- **Double-Strike Print** – Set: ESC F or ESC O
Clear: CR, ESC &, or ESC X

Characters and symbols are all printed out twice with no offset carriage movement. The double-strike print mode is overruled by the shadow mode if set. In the double-strike print mode, printing is executed only from left to right.

- **Print 20H** – Set: ESC Y

The character assigned to the ASCII code $(20)_{\text{Hex}}$ is printed out.

- **Print 7FH** – Set: ESC Z

The character assigned to the ASCII code $(7F)_{\text{Hex}}$ is printed out.

- **Eject Form** – Set: ESC EM R

Printed paper is only ejected without feeding the next page when CSF, DBSF.

- **Printer reset** – ESC CR P

All the data preceding this code are printed. Then, after confirming that operation has been completed, printer control unit is automatically reset, to return to the same condition immediately after power on.

- **Auto Centering Mode Set** – Set: ESC =
Clear: ESC X

The printing data stored in the buffer is printed in the center between the margins.

This function is executed by the following command: ESC + X, CR, LF, FF, ESC + CR + P, ESC + HT + n, ESC + 5, ESC + 6.

In centering mode ESC + 9, ESC + 0, ESC + 1, ESC + 3, CAN and DEL are ignored.

- **Auto Justification Mode Set** – Set: ESC M
Clear: ESC X

The printing data stored in the buffer is printed out resulting to justify the right margin.

This function is executed by the following command: ESC + X, CR, LF, FF, ESC + CR + P, ESC + 5, ESC + 6, VT, ESC + EM + n.

In justification mode, CAN and DEL are ignored.

Control Commands in DBSF Mode

When an optional dual bin sheet feeder is used, the paper tray can be selected by the following command.

- **ESC Command**

ESC EM n

With this command, sheet that is currently set is removed, then another sheet is inserted from the Tray specified by the following command.

<u>Code</u>	<u>Function</u>
ESC EM 1	Feed sheet from tray 1
ESC EM 2	Feed sheet from tray 2
ESC EM R	Remove (eject) paper/envelope
ESC EM E	Feed envelope from tray
ESC EM 3	Feed envelope from tray
ESC EM C	Feed sheet from tray 1 for first feed, then feed sheet from tray 2 thereafter or until a new command is issued.

● **TEXT Command**

This command can be used during documents of Word Processing Software.
After receiving this command, Tray to be next inserted is selected in feed page command such as the following FF.

//n//

<u>Command</u>	<u>Function</u>
----------------	-----------------

//1//	Select sheet from tray 1 (upper tray)
//2//	Select sheet from tray 2 (lower tray)
//R//	Select paper/envelope ejection
//C//	Select tray 1 for first feed, then select tray 2 thereafter or until a new command is issued.
//E//	Select envelope from tray 3 (Envelope tray)
//3//	Select envelope from tray 3 (Envelope tray)

Note

Sheet insertion by TOF or FF should be determined by DIP SW setting.

Printing in the Graphics Mode

An ESC 3 code sets the graphics mode and an ESC 4 or a CR code clears it. In the graphics mode, the carriage does not move automatically after printing. The carriage movement is controlled by codes such as space and backspace, which are fixed at 1/60 inch regardless of HMI, and line feed and reverse line feed, which are fixed at 1/48 inch regardless of VMI. Some control codes are affected by this mode and some are unchanged as fixed. The following table shows the difference between the standard mode and the graphics mode.

Control Code	Function
BEL	Same as standard mode
BS	1/60" backspace (independent of HMI)
HT	Same as standard mode
LF	1/48" line feed (independent of VMI)
VT FF DC1 DC3 CAN	Same as standard mode
SP	1/60" space (independent of HMI)
ESC BS ESC HT <i>n</i>	Same as standard mode
ESC LF	1/48" reverse line feed (independent of VMI)
ESC VT <i>n</i> ESC FF <i>n</i> ESC CR P ESC EM R ESC EM 1 ESC EM 2 ESC EM 3 ESC EM E ESC EM C ESC RS <i>n</i> ESC US <i>n</i> ESC " ESC # ESC %	Same as standard mode
ESC &	Active when the graphics mode is cleared
ESC =	invalid

Control Code	Function
ESC - ESC / ESC 0 ESC 1 ESC 2 ESC 5 ESC 6 ESC 8 ESC 9 ESC A ESC B ESC C ESC D	Same as standard mode
ESC E ESC F ESC H ESC I	Active when the graphics mode is cleared
ESC L	Same as standard mode
ESC M	Active when the graphics mode is cleared
ESC N	Same as standard mode
ESC O ESC P ESC Q ESC R ESC S	Active when the graphics mode is cleared
ESC T ESC U	Same as standard mode
ESC W ESC X	Active when the graphics mode is cleared
ESC Y ESC Z ESC \ //1// //2// //3// //E// //C// //R//	Same as standard mode

APPENDIX A TABLE OF ESC SEQUENCES

Classification	ESC Sequence	Hex Code	Function	Page
Print pitch	ESC P	1B 50	Setting PS mode	38
	ESC Q	1B 51	Clearing PS mode	38
	ESC US <i>n</i>	1B 1F <i>n</i>	Setting HMI [(<i>n</i> - 1) × 1/120)]	34
	ESC S	1B 53	Resetting to the control panel setting	34
LF pitch	ESC RS <i>n</i>	1B 1E <i>n</i>	Setting VMI [(<i>n</i> - 1) × 1/48)]	34
LF ² direction	ESC U	1B 55	Half line feed (half VMI)	37
	ESC D	1B 44	Reverse half line feed (half VMI)	37
	ESC LF	1B 0A	Reverse line feed	37
Margin	ESC 0	1B 30	Setting right margin at current position	35
	ESC 9	1B 39	Setting left margin at the current position	35
Horizontal tab	ESC HT <i>n</i>	1B 09 <i>n</i>	Absolute HT [HMI × (<i>n</i> - 1)]	36
	ESC 1	1B 31	Setting an HT stop at current position	35
	ESC 8	1B 38	Clearing the HT stop of current position	35
	ESC 2	1B 32	Clearing all HT and VT stops	35
Vertical tab	ESC VT <i>n</i>	1B 0B <i>n</i>	Absolute VT [VMI × (<i>n</i> - 1)]	36
	ESC -	1B 2D	Setting a VT stop at current position	35
	ESC 2	1B 32	Clearing all HT and VT stops	35
Page	ESC FF <i>n</i>	1B 0C <i>n</i>	Setting page length (<i>n</i> × VMI)	35
	ESC T	1B 54	Setting top margin at current position	36
	ESC L	1B 4C	Setting bottom margin at current position	36
	ESC C	1B 43	Clearing top and bottom margins	36
	ESC S	1B 53	Resetting to the DIP switch setting	34
Print system	ESC /	1B 2F	Setting auto backward printing	37
	ESC \	1B 5C	Clearing auto backward printing	37
	ESC 5	1B 35	Setting forward printing	37
	ESC 6	1B 36	Setting backward printing	37
Backspace	ESC BS	1B 08	1/120" backspacing	37
CR function	ESC "	1B 22	Auto LF ON (CR + LF)	37
	ESC #	1B 23	Auto LF OFF (CR only)	37
Color/black print	ESC A	1B 41	Color printing	38
	ESC B	1B 42	Printing in black	38
Specific code print	ESC Y	1B 59	Printing the code of 20H	38
	ESC Z	1B 5A	Printing the code of 7FH	38
Character style	ESC F	1B 46	Setting double-strike print mode	38
	ESC O	1B 4F	Setting double-strike print mode	38
	ESC W	1B 57	Setting shadow print mode	38
	ESC &	1B 26	Clearing double-strike, and shadow print modes	38
	ESC E	1B 45	Setting auto underline	38
	ESC R	1B 52	Clearing auto underline	38
	ESC H	1B 48	Setting auto-strike out	38
	ESC I	1B 49	Clearing auto-strike out	38
	ESC X	1B 58	Clearing auto underline, auto strike-out, shadow, and double-strike print modes	38
	ESC M	1B 4D	Setting auto justification mode	39
	ESC =	1B 3D	Setting auto centering mode	39
Paper eject	ESC EM R	1B 19 52	Ejecting paper during CSF or DBSF mode.	38
Printer reset	ESC CR P	1B 0D 50	Resetting the printer	39

Classification	ESC Sequence	Hex Code	Function	Page
Graphics print set	ESC 3	1B 33	Setting the Graphics print mode	41
Graphics print reset	ESC 4	1B 34	Resetting the Graphics print mode	41
DBSF Control Command	ESC EM 1	1B 19 31	Eject paper on the platen and feed the next paper from Tray 1.	39
	ESC EM 2	1B 19 32	Eject paper on the platen and feed the next paper from Tray 2.	39
	ESC EM 3	1B 19 33	Eject paper on the platen and feed the next paper from Envelope Tray.	39
	ESC EM E	1B 19 45	Same as ESC EM 3.	39
	ESC EM C	1B 19 43	Eject paper on the platen and feed the paper from Tray 1 for first feed. Then select 2nd Tray for the next page.	39

Classification	Text Command	Function	
DBSF Control	//1//	TRAY1 SELECT	39
	//2//	TRAY2 SELECT	39
	//3//	ENVELOPE TRAY SELECT	39
	//E//	ENVELOPE TRAY SELECT	39
	//C//	TRAY1 & TRAY2 SELECT	39
	//R//	Ejecting paper	39

Note 1

Switching print pitch by codes does not change lighting of control panel lamps.

Note 2

n is any value from HEX (01) to HEX (7E).

APPENDIX B INTERFACE SPECIFICATIONS

Centronics Parallel Interface

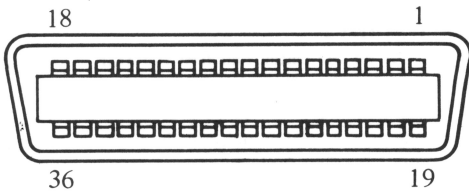

Connector Types

Printer-side connector:
Amphenol (DDK) S7LE-40360 or equivalent

Cable-side connector:
Amphenol (DDK) S7-30360 or equivalent

Connector Pin Assignment

Pin No.	Signal Name	Direction	Description
1	DATA STROBE	Input	This strobe reads data (DATA 1 through 8). The minimum pulse width should be 1 μ sec. This signal is normally high and data are read when it changes to low level. By option, the strobe condition can be inverted so that data are read when the level changes to high.
2	DATA 1	Input	DATA 1 through 8 correspond respectively to each bit: 1 – High 0 – Low
3	DATA 2		
4	DATA 3		
5	DATA 4		
6	DATA 5		
7	DATA 6		
8	DATA 7		
9	DATA 8		
10	ACKNLG	Output	Acknowledges data reception. The pulse width is $5 \pm 1 \mu$ sec. This signal is normally high.
11	BUSY	Output	Indicates whether the printer is busy or ready. When ready, this signal is low. Only a DC 1 code can be accepted when this signal is high.
12	PE	Output	1. With a cut sheet feeder: Changes to high if no form are set. 2. With a tractor feeder: Changes to high when the printer is nearly out of paper.
13	SLCT	Output	Becomes high when the printer is selected: on-line.
14	–	–	–
15	–	–	–
16	0V	–	Frame ground/signal ground
17	5V	–	Power supply line
18	5V	–	Power supply line
19	TWISTED PAIR GND	–	Signal line return ground
20			
21			
22			
23			
24			
25			
26			
27			
28			
29			
30	INPUT PRIME RET	–	Return ground of INPUT PRIME
31	INPUT PRIME	Input	Initializes the printer.
32	FAULT	Output	Becomes low when the printer enters into any of the following conditions: a. Paper empty (PE) d. Printer error b. Ribbon empty (RE) e. Off-line state c. Top cover open
33	–	–	–
34	–	–	–
35	–	–	–
36	–	–	–

RS-232C Serial Interface

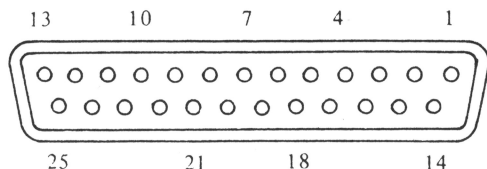

Connector Type

Printer side: Hirose RDBD-25S or equivalent

Cable side: Hirose RDBD-25P or equivalent

Specifications

Transmission Rate (Baud)	110, 150, 300, 600, 1200, 2400, 4800, 9600
Synchronization	Start-stop
Communications Control	No protocol
Data Format	10 bits/character SPACE $\overline{\text{ST}}$ b1, b2, b3, b4, b5, b6, b7, b8, SP MARK A character begins with a start bit (a change from MARK to SPACE). The line is at the MARK level when data are absent. where ST: Start bit b1 – b7: Data bits (b1 is LSB) b8: Parity bit (MSB with the 8-bit code) SP: Stop bit
Error Mark	Prints the ASCII symbol assigned to 40H when vertical parity error, framing error, or overrun error is detected.

Signal Level

Logic	Standard level	At receiving end
MARK (OFF)	-12V	-3V maximum
SPACE (ON)	+12V	+3V minimum

Connector Pin Assignment

Pin No.	Signal	Symbol	Direction	Description
1	Frame GND	FG	–	Grounding for frame
2	Send Data	SD	Output	Data line from printer to computer
3	Receive Data	RD	Input	Data line from computer to printer
4	Request to Send	RS	Output	Always high
5	Clear to Send	CS	Input	DC1 and DC3 are output when this line is at high level. Keep this line high
6	Data Set Ready	DR	Input	Printer accepts data when this line is at high level.
7	Signal GND	SG	–	Grounding for signals
8	Carrier Detect	CD	Input	Printer accepts data when this line is at high level.
11	Secondary Request to Send (reverse channel)	SCA	Output	High when printer is busy.
20	Data Terminal Ready	ER	Output	Low when printer is busy.

Note 1: The frame GND and the signal GND are common.

Note 2: Pins #5, #6, and #8 is always at high level if it is not connected.

APPENDIX C SERIAL INTERFACE SAMPLE CONNECTION

Interfacing with the IBM PC and PC XT

Connection Diagram

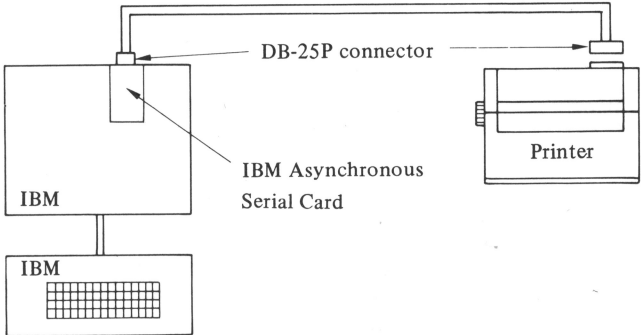

You need an optional IBM Asynchronous Serial Card, available from your dealer and a correct printer interface cable having the following pin configuration:

IBM PC DB-25P (female)		Printer DB-25P (male)	
FG	1	1	FG
TXD	2	3	RD
RXD	3	2	SD
RTS	4		
DSR	6		
SG	7	7	SG
CTS	5	20	ER

Settings of DIP Switches of Printer

Please refer to chapter 5 for further reference.

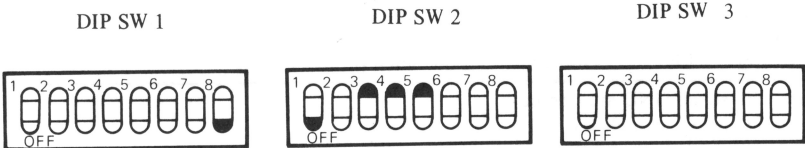

Installation

The following system command sequence sets the RS-232C interface options to 9600 bauds, no parity, 8 data bits, 1 stop bit, and continuous time-out retry.

1. Insert the system disk, boot PC DOS, and wait for the prompt (A >) to appear.
2. Use the MODE command to set the interface options:
A > MODE COM1: 96, N, 8, 1, P [RETURN]
3. Use the MODE command again to redirect the printer output to the RS-232C port:
A > MODE LPT1: = COM1: [RETURN]

Both those MODE commands should be entered every time you turn on the computer/printer system, unless you use the AUTOBAT routine (DOS Utilities) to save the commands and have them executed automatically each time the system is booted. The AUTOBAT routine is as follows:

1. Insert the system disk, boot PC DOS Ver. 2.0 & 2.1, and wait for the prompt (A >) to appear.
2. Key in after the prompt like
A > COPY CON: AUTOEXEC. BAT [RETURN]
A > MODE COM1: 96, N, 8, 1, P [RETURN]
A > MODE LPT1: = COM1: [RETURN]
3. Press the [F6] function key and press [RETURN].

The routine is saved on the system disk, so that it will be executed automatically every time the system is booted.

Note

The power ON/OFF sequence for the computer/printer system should be as follows:

Power ON First turn on the IBM PC then the Printer
Power OFF First turn off the Printer then the IBM PC

If these sequences are not followed, spurious characters may be printed out with the Printer when the computer is switched off or on.

Note

IBM PC and PC XT are registered trademarks of International Business Machines Corporation.

Interfacing with the Apple IIc

Connection Diagram

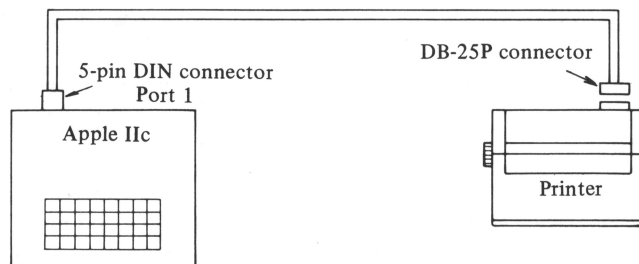

The Printer can be connected directly to the 5-pin DIN socket (port 1) on the rear side of the computer. You need to obtain a suitable cable having the following pin configuration.

Apple IIc 5-pin DIN (male)		Printer DB-25P (male)
FG	* ————— 1	FG
RXD	4 ————— 2	SD
TXD	2 ————— 3	RD
GND	3 ————— 7	SG
DSR	5 ————— 20	ER

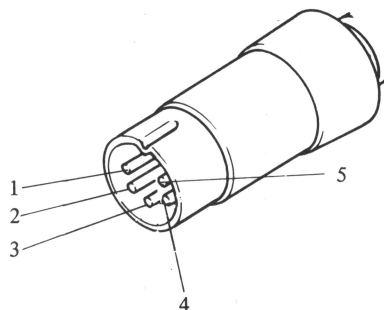

*Connect the Frame Ground (FG) to the DIN connector case at the Apple IIc side.

Settings of DIP Switches of Printer

Please refer to chapter 5 for further reference.

DIP SW 1

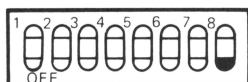

DIP SW 2

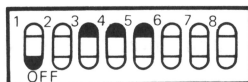

DIP SW 3



Installation

The Printer is installed via the System Utilities (Ver. 1.0). Once installed, the computer remains compatible with the Printer until any reinstallation is carried out via the system utilities. Always work with a copy of the system disk to protect the master disk. Make a copy system disk by selecting <5. Duplicate a disk> in the System Utilities Menu and proceed as follows:

1. Insert the copied disk in the drive and turn on the power.
2. Select <8. Advanced Operations> on the Main Menu under <Work on Entire Disks> and press [RETURN].
3. Select <5. Configure the Serial Ports> under <Additional Operations> and press [RETURN].
4. Select <3. Edit the Device List> in response to the question <What do you want to do?> and press [RETURN].
5. When <Select Device to Replace> appears, select <5. Your Device> and press [RETURN].
6. When <Enter New Device Name:> appears, type in <HR-40> and press [RETURN].
7. Select <Yes> in response to <Do you know what PIN to use?> and press [RETURN].
8. When <Enter New Pin:> appears, type <156/1125> and press [RETURN]. Settings are made as follows:
 - PRINTER MODE
 - 8 Data Bits/1 Stop Bit
 - 9600 Bits per Second
 - No parity
 - Do Not Echo Output on Screen
 - Insert LF After CR
 - Insert CR After 132 Characters
9. When <Is this PIN correct?> appears, select <Yes> and press [RETURN].

10. When <Save this configuration to disk?> appears, select <Yes> and press [RETURN].
11. Press the [ESC] key if you want to exit without saving the configuration, or to reselect another configuration.
12. Select <1. Set Port 1> on the menu in response to <What do you what to do?> and press [RETURN].
13. When <Select the device for Port 1:> appears, select <HR-40(156/1125)> and press [RETURN].
14. When <Save this configuration to disk?> appears, select <Yes> and press [RETURN].
15. Press the [ESC] key twice to return to Main Menu.
16. Select <9. Exit System Utilities> and press [RETURN].
17. When <Are you sure you want to leave System Utilities?> appears, select <Yes> and press [RETURN].

The Printer is now installed for your Apple computer. To run a program on another disk, boot your computer in System Utilities, change the disk, type <]PR#6>, and press [RETURN].

Note

The power ON/OFF sequence for the computer/printer system should be as follows:

- Power ON First turn on the Apple IIc then the Printer
- Power OFF First turn off the Printer then the Apple IIc

If these sequences are not followed, spurious characters may be printed out with the Printer when the computer is switched off or on.

Note

Apple IIc is a registered trademark of Apple Computer Inc.

Interfacing with the Apple Macintosh

Connection Diagram

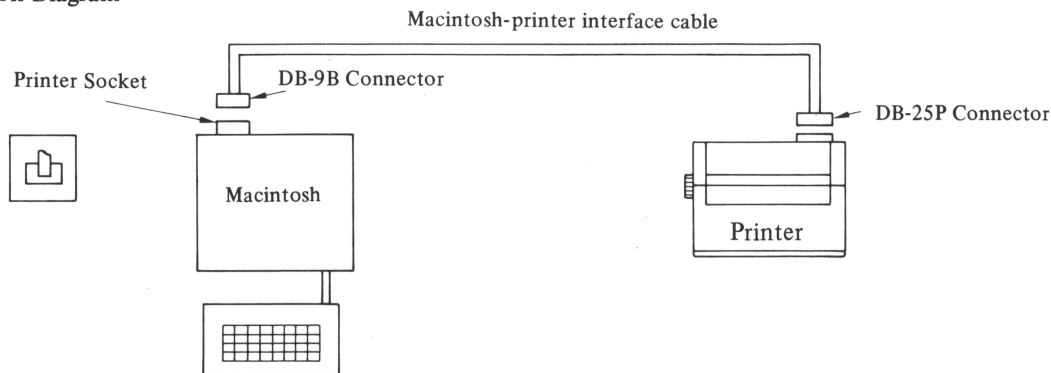

As a Macintosh is normally configured for a dot matrix type printer, you need to obtain a special software program (e.g. Mac Daisywheel Connection marketed by Assimilation Process) for Macintosh to drive the Printer. You also need a dedicated interface cable having the following pin configuration.

Macintosh DB-9P (male)		Printer DB-25B (male)	
GND	3	7	SG
TXD	5	3	RD
DSR	7	20	ER
RXD	9	2	SD

Settings of DIP Switches of Printer

Please refer to chapter 5 for further reference.

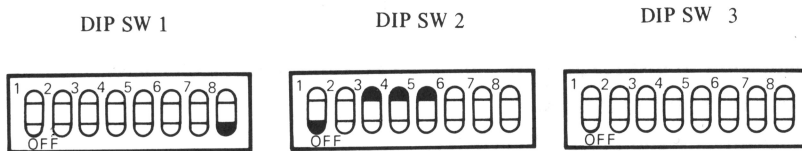

Installation

Always work with a copy of your software disk to protect the master disk. You need to use the Mac Daisywheel Connection software disk each time you want to print out on your Printer. Refer to the Macintosh Instruction Manual for alternative ways of selecting and opening files.

Printing a Document

1. Turn on the computer, insert Mac Daisywheel Connection program disk, and then turn on the Printer in this order.
2. Double Click the mouse button to open the disk icon.
3. Click the Daisywheel Connection icon to select it. Then choose open from the File menu or click your mouse twice to open Daisywheel Connection.
4. When <mac•daisywheel•connection> is displayed, click the mouse button to advance.
5. Select the following Printer Mode setting:
Printer: Brother HR Series
Output to: Printer Port
Baud Rate: 9600
6. Click [OK]
The Printer is now ready to print out.
 - If you want to print the Sample Memo to test the connection and settings, click the Sample Memo then position the pointer over Open and click.
 - If you don't want to print the Sample Memo and you want to try one of your own files, click [EJECT] and inset the file disk you want to print into the disk drive.
Click the document you want to print and move the pointer over to Open and click.
The file can then be printed out with the Printer

Note

The power ON/OFF sequence for the computer/printer system should be as follows:

Power ON First turn on the Macintosh then the Printer
Power OFF First turn off the Printer then the Macintosh

If these sequences are not followed, spurious characters may be printed out with the Printer when the computer is switched off or on.

Note

Apple Macintosh is a registered trademark of Apple Computer Inc. Mac Daisywheel Connection is a registered trademark of Assimilation Process.

APPENDIX D ASCII CODE TABLES (by Language Group)

*** US ASCII ***

b ₈ -- →	0	0	0	0	0	0	0
b ₇ -- →	0	0	0	0	1	1	1
b ₆ -- →	0	0	1	1	0	0	1
b ₅ -- →	0	1	0	1	0	1	0
b ₄ b ₃ b ₂ b ₁	0	1	2	3	4	5	6
0 0 0 0	0	NUL	¢	0	@	P	`
0 0 0 1	1	DC1	!	1	A	Q	a
0 0 1 0	2		"	2	B	R	b
0 0 1 1	3	DC3	#	3	C	S	c
0 1 0 0	4		\$	4	D	T	d
0 1 0 1	5		%	5	E	U	e
0 1 1 0	6		&	6	F	V	f
0 1 1 1	7	BEL	'	7	G	W	g
1 0 0 0	8	BS	(8	H	X	h
1 0 0 1	9	CAN)	9	I	Y	i
1 0 1 0	A	EM	*	:	J	Z	j
1 0 1 1	B	VT	+	;	K	[k
1 1 0 0	C	ESC	,	<	L	\	
1 1 0 1	D	FF	-	=	M]	m
1 1 1 0	E	CR	.	>	N	^	n
1 1 1 1	F	RS	/	?	O	_	o
		US					

Note

Although control characters are common, characters specific to each language are shown in the following tables.

*** GERMAN 1 ***

	2	3	4	5	6	7
0	µ	0	§	P	`	p
1	!	1	A	Q	a	q
2	"	2	B	R	b	r
3	#	3	C	S	c	s
4	\$	4	D	T	d	t
5	%	5	E	U	e	u
6	&	6	F	V	f	v
7	'	7	G	W	g	w
8	(8	H	X	h	x
9)	9	I	Y	i	y
A	*	:	J	Z	j	z
B	+	;	K	[k	{
C	,	<	L	\		
D	-	=	M]	m	~
E	.	>	N	^	n	˘
F	/	?	O	_	o	˘

*** UK ENGLISH ***

	2	3	4	5	6	7
0	¢	0	@	P	$\frac{1}{3}$	p
1	°	1	A	Q	a	q
2	"	2	B	R	b	r
3	£	3	C	S	c	s
4	\$	4	D	T	d	t
5	%	5	E	U	e	u
6	&	6	F	V	f	v
7	'	7	G	W	g	w
8	(8	H	X	h	x
9)	9	I	Y	i	y
A	*	:	J	Z	j	z
B	+	;	K	[k	$\frac{1}{4}$
C	,	<	L	\		$\frac{1}{2}$
D	-	=	M]	m	˙
E	.	>	N	^	n	˚
F	/	?	O	_	o	˚

*** UK ASCII ***

	2	3	4	5	6	7
0	#	0	@	P	`	p
1	!	1	A	Q	a	q
2	"	2	B	R	b	r
3	£	3	C	S	c	s
4	\$	4	D	T	d	t
5	%	5	E	U	e	u
6	&	6	F	V	f	v
7	'	7	G	W	g	w
8	(8	H	X	h	x
9)	9	I	Y	i	y
A	*	:	J	Z	j	z
B	+	;	K	[k	{
C	,	<	L	\		
D	-	=	M]	m	~
E	.	>	N	^	n	˘
F	/	?	O	_	o	˘

*** UK ASCII 2 ***

	2	3	4	5	6	7
0	˘	0	@	P	£	p
1	!	1	A	Q	a	q
2	"	2	B	R	b	r
3	#	3	C	S	c	s
4	\$	4	D	T	d	t
5	%	5	E	U	e	u
6	&	6	F	V	f	v
7	'	7	G	W	g	w
8	(8	H	X	h	x
9)	9	I	Y	i	y
A	*	:	J	Z	j	z
B	+	;	K	[k	{
C	,	<	L	\		
D	-	=	M]	m	~
E	.	>	N	^	n	˘
F	/	?	O	_	o	˘

*** FRENCH 1 ***

	2	3	4	5	6	7
0	$\frac{1}{4}$	0	à	P	±	p
1	!	1	A	Q	a	q
2	"	2	B	R	b	r
3	£	3	C	S	c	s
4	\$	4	D	T	d	t
5	%	5	E	U	e	u
6	&	6	F	V	f	v
7	'	7	G	W	g	w
8	(8	H	X	h	x
9)	9	I	Y	i	y
A	*	:	J	Z	j	z
B	+	;	K	°	k	é
C	,	<	L	ç	l	ù
D	-	=	M	ç	l	ù
E	.	>	N	˘	n	˘
F	/	?	O	_	o	$\frac{1}{2}$

*** DUTCH ***

	2	3	4	5	6	7
0	$\frac{3}{4}$	0	h	P	`	p
1	!	1	A	Q	a	q
2	"	2	B	R	b	r
3	£	3	C	S	c	s
4	\$	4	D	T	d	t
5	%	5	E	U	e	u
6	&	6	F	V	f	v
7	'	7	G	W	g	w
8	(8	H	X	h	x
9)	9	I	Y	i	y
A	*	:	J	Z	j	z
B	+	;	K	°	k	$\frac{1}{4}$
C	,	<	L	±	l	$\frac{1}{2}$
D	-	=	M	f	m	$\frac{1}{2}$
E	.	>	N	˘	n	˘
F	/	?	O	_	o	˘

*** ITALIAN ***

	2	3	4	5	6	7
0	²	0	§	P	ù	p
1	!	1	A	Q	a	q
2	"	2	B	R	b	r
3	£	3	C	S	c	s
4	\$	4	D	T	d	t
5	%	5	E	U	e	u
6	&	6	F	V	f	v
7	'	7	G	W	g	w
8	(8	H	X	h	x
9)	9	I	Y	i	y
A	*	:	J	Z	j	z
B	+	;	K	°	k	à
C	,	<	L	ç	l	ò
D	-	=	M	ç	l	ò
E	.	>	N	˘	n	ì
F	/	?	O	_	o	˚

*** S. SPANISH ***

	2	3	4	5	6	7
0	²	0	°	P	`	p
1	!	1	A	Q	a	q
2	"	2	B	R	b	r
3	£	3	C	S	c	s
4	\$	4	D	T	d	t
5	%	5	E	U	e	u
6	&	6	F	V	f	v
7	'	7	G	W	g	w
8	(8	H	X	h	x
9)	9	I	Y	i	y
A	x	:	J	Z	j	z
B	+	;	K	$\frac{1}{2}$	k	ñ
C	,	<	L	Ñ	l	ñ
D	-	=	M	˘	m	ç
E	.	>	N	˘	n	ç
F	/	?	O	_	o	˚

*** WP OF AMERICAN ENGLISH ***

	2	3	4	5	6	7
0		0	@	P	°	p
1	!	1	A	Q	a	q
2	"	2	B	R	b	r
3	#	3	C	S	c	s
4	\$	4	D	T	d	t
5	%	5	E	U	e	u
6	&	6	F	V	f	v
7	'	7	G	W	g	w
8	(8	H	X	h	x
9)	9	I	Y	i	y
A	*	:	J	Z	j	z
B	+	;	K	[k	[
C	,	<	L]	l]
D	-	=	M]	m]
E	.	>	N	^	n	^
F	/	?	O	_	o	_

*** SYMBOL ***

	2	3	4	5	6	7
0	x	0	^	ℓ	ƒ	ρ
1	@	1	∇	Γ	α	γ
2	"	2	∞	∅	β	θ
3	·	3	ψ	Σ	Ψ	σ
4	±	4	φ	→	φ	τ
5	∫	5	+	≡	ε	ξ
6	÷	6	<	Λ	>	δ
7	√	7	∧	Δ	λ	x
8	∪	8	∩	≡	η	χ
9		9	↑	T	ι	υ
A	·	:	∏	≈	π	ζ
B	,	<	∫	≠	+	{
C	,	<	∫	Ω	ω	}
D	≠	=	∂	∞	μ	≤
E	∞	∞	∞	∞	ν	≥
F	∞	∞	∞	∞	o	∞

*** INTERNATIONAL ***

	2	3	4	5	6	7
0	°	0	B	P	`	p
1	!	1	A	Q	a	q
2	"	2	B	R	b	r
3	#	3	C	S	c	s
4	\$	4	D	T	d	t
5	%	5	E	U	e	u
6	&	6	F	V	f	v
7	'	7	G	W	g	w
8	(8	H	X	h	x
9)	9	I	Y	i	y
A	*	:	J	Z	j	z
B	+	;	K	[k	[
C	,	<	L]	l]
D	-	=	M]	m]
E	.	>	N	^	n	^
F	/	?	O	_	o	_

*** AMERICAN ENGLISH ***

	2	3	4	5	6	7
0	¢	0	@	P	°	p
1	!	1	A	Q	a	q
2	"	2	B	R	b	r
3	#	3	C	S	c	s
4	\$	4	D	T	d	t
5	%	5	E	U	e	u
6	&	6	F	V	f	v
7	'	7	G	W	g	w
8	(8	H	X	h	x
9)	9	I	Y	i	y
A	*	:	J	Z	j	z
B	+	;	K	[k	[
C	,	<	L]	l]
D	-	=	M]	m]
E	.	>	N	^	n	^
F	/	?	O	_	o	_

*** PORTUGUESE ***

	2	3	4	5	6	7
0	∕	0	§	P	`	p
1	!	1	A	Q	a	q
2	"	2	B	R	b	r
3	£	3	C	S	c	s
4	\$	4	D	T	d	t
5	%	5	E	U	e	u
6	&	6	F	V	f	v
7	'	7	G	W	g	w
8	(8	H	X	h	x
9)	9	I	Y	i	y
A	*	:	J	Z	j	z
B	+	;	K	[k	[
C	,	<	L]	l]
D	-	=	M]	m]
E	.	>	N	^	n	^
F	/	?	O	_	o	_

*** LATIN-AMERICA SPANISH ***

	2	3	4	5	6	7
0	[0	±	P	`	p
1	!	1	A	Q	a	q
2	"	2	B	R	b	r
3	#	3	C	S	c	s
4	\$	4	D	T	d	t
5	%	5	E	U	e	u
6	&	6	F	V	f	v
7	'	7	G	W	g	w
8	(8	H	X	h	x
9)	9	I	Y	i	y
A	*	:	J	Z	j	z
B	+	;	K	[k	[
C	,	<	L]	l]
D	-	=	M]	m]
E	.	>	N	^	n	^
F	/	?	O	_	o	_

*** CANADIAN ***

	2	3	4	5	6	7
0	°	0	§	P	`	p
1	!	1	A	Q	a	q
2	"	2	B	R	b	r
3	#	3	C	S	c	s
4	\$	4	D	T	d	t
5	%	5	E	U	e	u
6	&	6	F	V	f	v
7	'	7	G	W	g	w
8	(8	H	X	h	x
9)	9	I	Y	i	y
A	*	:	J	Z	j	z
B	+	;	K	[k	[
C	,	<	L]	l]
D	-	=	M]	m]
E	.	>	N	^	n	^
F	/	?	O	_	o	_

*** SWISS ***

	2	3	4	5	6	7
0	°	0	§	P	`	p
1	!	1	A	Q	a	q
2	"	2	B	R	b	r
3	£	3	C	S	c	s
4	\$	4	D	T	d	t
5	%	5	E	U	e	u
6	&	6	F	V	f	v
7	'	7	G	W	g	w
8	(8	H	X	h	x
9)	9	I	Y	i	y
A	*	:	J	Z	j	z
B	+	;	K	[k	[
C	,	<	L]	l]
D	-	=	M]	m]
E	.	>	N	^	n	^
F	/	?	O	_	o	_

*** NORWEGIAN & DANISH ***

	2	3	4	5	6	7
0	½	0	§	P	`	p
1	!	1	A	Q	a	q
2	"	2	B	R	b	r
3	£	3	C	S	c	s
4	\$	4	D	T	d	t
5	%	5	E	U	e	u
6	&	6	F	V	f	v
7	'	7	G	W	g	w
8	(8	H	X	h	x
9)	9	I	Y	i	y
A	*	:	J	Z	j	z
B	+	;	K	[k	[
C	,	<	L]	l]
D	-	=	M]	m]
E	.	>	N	^	n	^
F	/	?	O	_	o	_

*** FINNISH & SWEDISH ***

	2	3	4	5	6	7
0	½	0	§	P	`	p
1	!	1	A	Q	a	q
2	"	2	B	R	b	r
3	#	3	C	S	c	s
4	\$	4	D	T	d	t
5	%	5	E	U	e	u
6	&	6	F	V	f	v
7	'	7	G	W	g	w
8	(8	H	X	h	x
9)	9	I	Y	i	y
A	*	:	J	Z	j	z
B	+	;	K	[k	[
C	,	<	L]	l]
D	-	=	M]	m]
E	.	>	N	^	n	^
F	/	?	O	_	o	_

*** GERMAN 2 ***

	2	3	4	5	6	7
0	°	0	§	P	`	p
1	!	1	A	Q	a	q
2	"	2	B	R	b	r
3	#	3	C	S	c	s
4	\$	4	D	T	d	t
5	%	5	E	U	e	u
6	&	6	F	V	f	v
7	'	7	G	W	g	w
8	(8	H	X	h	x
9)	9	I	Y	i	y
A	*	:	J	Z	j	z
B	+	;	K	[k	[
C	,	<	L]	l]
D	-	=	M]	m]
E	.	>	N	^	n	^
F	/	?	O	_	o	_

*** FRENCH 2 ***

	2	3	4	5	6	7
0	±	0	à	P	`	p
1	!	1	A	Q	a	q
2	"	2	B	R	b	r
3	#	3	C	S	c	s
4	\$	4	D	T	d	t
5	%	5	E	U	e	u
6	&	6	F	V	f	v
7	'	7	G	W	g	w
8	(8	H	X	h	x
9)	9	I	Y	i	y
A	*	:	J	Z	j	z
B	+	;	K	[k	[
C	,	<	L]	l]
D	-	=	M]	m]
E	.	>	N	^	n	^
F	/	?	O	_	o	_

*** 8BIT NORWEIGIAN & DANISH ***

	2	3	4	5	6	7	8	9	A	B	C	D	E	F
0	½	0		P	`	p	Ç	É	á					
1	!	1	A	Q	a	q	Û	æ	í					±
2	"	2	B	R	b	r	ü	ø	ó					±
3	#	3	C	S	c	s	ä	ö	ú					±
4	\$	4	D	T	d	t	å	õ	ñ					±
5	%	5	E	U	e	u	ä	ö	ú	n				±
6	&	6	F	V	f	v	å	ö	ú	n				±
7	'	7	G	W	g	w	ç	ë	ë					±
8	(8	H	X	h	x	ç	ë	ë					±
9)	9	I	Y	i	y	ç	ë	ë					±
A	*	:	J	Z	j	z	ç	ë	ë					±
B	+	;	K	[k	{	ç	ë	ë					±
C	<	<	L	\	l		ç	ë	ë					±
D	=	=	M]	m	}	ç	ë	ë					±
E	>	>	N	^	n	~	ç	ë	ë					±
F	/	?	O	_	o	-	ç	ë	ë					±

*** 8BIT FINNISH & SWEDISH ***

	2	3	4	5	6	7	8	9	A	B	C	D	E	F
0	½	0		P		p	Ç	É	á					
1	!	1	A	Q	a	q	Û	æ	í					±
2	"	2	B	R	b	r	ü	ø	ó					±
3	#	3	C	S	c	s	ä	ö	ú					±
4	\$	4	D	T	d	t	å	õ	ñ					±
5	%	5	E	U	e	u	ä	ö	ú	n				±
6	&	6	F	V	f	v	å	ö	ú	n				±
7	'	7	G	W	g	w	ç	ë	ë					±
8	(8	H	X	h	x	ç	ë	ë					±
9)	9	I	Y	i	y	ç	ë	ë					±
A	*	:	J	Z	j	z	ç	ë	ë					±
B	+	;	K	[k	{	ç	ë	ë					±
C	<	<	L	\	l		ç	ë	ë					±
D	=	=	M]	m	}	ç	ë	ë					±
E	>	>	N	^	n	~	ç	ë	ë					±
F	/	?	O	_	o	-	ç	ë	ë					±

*** COMBINATION ***

	2	3	4	5	6	7	8	9	A	B	C	D	E	F
0	ø	0	@	P	`	p	Ç	É	á					±
1	!	1	A	Q	a	q	Û	æ	í					±
2	"	2	B	R	b	r	ü	ø	ó					±
3	#	3	C	S	c	s	ä	ö	ú					±
4	\$	4	D	T	d	t	å	õ	ñ					±
5	%	5	E	U	e	u	ä	ö	ú	n				±
6	&	6	F	V	f	v	å	ö	ú	n				±
7	'	7	G	W	g	w	ç	ë	ë					±
8	(8	H	X	h	x	ç	ë	ë					±
9)	9	I	Y	i	y	ç	ë	ë					±
A	*	:	J	Z	j	z	ç	ë	ë					±
B	+	;	K	[k	{	ç	ë	ë					±
C	<	<	L	\	l		ç	ë	ë					±
D	=	=	M]	m	}	ç	ë	ë					±
E	>	>	N	^	n	~	ç	ë	ë					±
F	/	?	O	_	o	-	ç	ë	ë					±

APPENDIX E TROUBLESHOOTING AND MAINTENANCE

Troubleshooting

When any problems occur in printer functions or related mechanisms and parts, we suggest taking a few minutes to evaluate the situation on your own. With the help of the following tables when necessary, most minor problems can be rectified within minutes. You will be learning more about the use of the printer, and will perhaps discover that if you inadvertently caused the trouble, you will be less likely to repeat the same mistake again. When all attempts fail, however, do not hesitate to contact your dealer.

Basic Errors

Symptom	Possible Cause	Corrective Action
Printer does not operate at all	<ul style="list-style-type: none"> • Power cord not connected • Power switch OFF 	<ul style="list-style-type: none"> • Plug power cord into electrical outlet • Turn power switch ON
Printer is on and data are sent, but printer does not print	<ul style="list-style-type: none"> • Cable between computer and printer not connected • Printer off-line • INTERFACE switch not set correctly 	<ul style="list-style-type: none"> • Check to verify that connectors of interface cable are properly connected both at the computer and printer • Press SEL switch • Set INTERFACE switch correctly

Print Quality Errors

Symptom	Possible Cause	Corrective Action
Prints incorrectly	<ul style="list-style-type: none"> • Daisy wheel not positioned properly • DIP switch setting incorrect 	<ul style="list-style-type: none"> • Reinstall daisy wheel • Correct DIP switch setting
Paper is smudged or soiled by ribbon	<ul style="list-style-type: none"> • Ribbon twisted or incorrectly installed 	<ul style="list-style-type: none"> • Remove and reinstall ribbon cassette
Uneven lines in printout	<ul style="list-style-type: none"> • Paper release lever set to OPEN 	<ul style="list-style-type: none"> • Close paper release lever
Printing is too light or has drop-outs	<ul style="list-style-type: none"> • Impression control set incorrectly • Worn ribbon 	<ul style="list-style-type: none"> • Adjust impression control • Replace ribbon
Print is too dark	<ul style="list-style-type: none"> • Impression control set incorrectly 	<ul style="list-style-type: none"> • Adjust impression control

Ribbon Errors

Symptom	Possible Cause	Corrective Action
Ribbon breaks	<ul style="list-style-type: none"> • Ribbon ink supply depleted Replace when printout becomes light (fabric ribbon) 	<ul style="list-style-type: none"> • Remove worn ribbon • Install new ribbon cassette
Ribbon folds over Ribbon does not move smoothly	<ul style="list-style-type: none"> • Ribbon improperly installed • Ribbon twisted or improperly installed 	<ul style="list-style-type: none"> • Reinstall ribbon cassette • Reinstall ribbon cassette

Paper Feed Errors

Symptom	Possible Cause	Corrective Action
Paper is not fed properly	<ul style="list-style-type: none">• Paper jammed, crumpled, twisted, etc. in paper path• DIP switch for auto line feed is not set properly	<ul style="list-style-type: none">• Remove damaged paper from printer• Correct necessary DIP switch
Paper buckles, twists, crumples, or jams	<ul style="list-style-type: none">• Paper release lever OPEN	<ul style="list-style-type: none">• Close paper release lever

Even if the printer still malfunctions after checking as above, contact your dealer.

Maintenance

Your printer is virtually a maintenance-free device. It does, however, require the same general care given to your other computer equipment. Refrain from making any adjustments, changes to the mechanism, switch alterations, or repairs on your own. This is a precision device which requires authorized servicing of major repairs and replacements. Following the general guidelines for printer care:

- Carefully remove scraps; and torn pieces after paper problems.
- Limit cleaning to visible, external areas. Don't probe deep into the printer case.
- Never place or keep anything on the printer.
- Be careful of small objects such as paper clips and staples, that could fall into the printer.
- Daisy wheels are encased in clear drop-in cassettes. Don't touch the exposed spokes.
- Maintain the platen in good condition by cleaning it regularly with alcohol.

APPENDIX F PRINTER SPECIFICATIONS

Print speed	40 cps max
Daisy wheel characters	96 characters – cassette type easy to change
Characters/line	136 characters (1/10") 163 characters (1/12") 204 characters (1/15")
Forms width	SHEET : 16.6" max. CSF : A4 or U.S. letter size FORMS : 4.25" – 15" DBSF : 7" – 14" (Paper) 8" – 9 1/2" (Envelope)
Number of copies	Original + 4 copies
Ribbon cassette	Multi Strike Ribbon 250,000 characters (Multi setting) One Time Ribbon 70,000 characters Fabric Ribbon 500,000 characters Correctable Ribbon 70,000 characters
Interface	Dual (Centronics parallel and RS-232C serial)
Switch panel	Lamps: POWER, ON LINE, ALARM, PITCH, COPY, DATA FULL, MULTI, LOAD Switches: SEL, LF, TOF, PITCH, COPY MODE, REPRINT, LOAD
Temperature	50 to 104°F (10 to 40°C) during operation
Humidity	20 to 80% during operation
Buffer capacity	8K, optional 16K
Overall dimensions	23.1"(W) x 13.4"(D) x 7.7"(H) [588mm (W) x 340mm (D) x 196mm (H)]
Weight	31.9 pounds [14.5 kg]

Specifications are subject to change without notice, as changes may be made to improve performance.

APPENDIX G OPTIONS AND ACCESSORIES

The following options and accessories are available through your dealer:

1. Ribbon Cassette

- Correctable carbon (7020)
- Multi-strike carbon (7040)
- One-time carbon (7022)
- Fabric (8020)

2. Daisy Wheel

A variety of fonts available with drop-in cassettes. Note that changing the daisy wheel may require resetting the DIP switch concerned.

3. Red Spool Ribbon

Red spool ribbons available for color printing.

4. Dual Bin Sheet Feeder (CF500)

The intent of this manual is to provide as much operational and technical information as possible when interfacing the Brother product to your computer.

Since it is not practical to include specific information on each and every make and model of computer, the enclosed written examples and functional codes are presented in a computer format similar to the needs of a wide range of software.

Thus, it is the customer's responsibility to obtain the necessary information and equipment to interface the printer with their individual computer.

However, it should be noted that the specifications contained in your computer and software manual are indispensable for a safe and satisfactory connection.

If the printer still malfunctions after you check it according to this manual, contact your dealer. You may also call Brother at our toll-free number 800-526-3537.

