

**Nikon**

Autofocus Speedlight

**SB-23**

**INSTRUCTION MANUAL**

**E**

# FOREWORD

Thank you for purchasing the Nikon Autofocus Speedlight SB-23. We hope the SB-23 will make photography a much bigger part of your life. Get to know your SB-23, but before using it, be sure to read both your camera instruction manual and this manual. Nikon cannot be held responsible for malfunctions resulting from use of the SB-23 other than as specified in this manual, or from use of the SB-23 with a camera made by a manufacturer other than Nikon.

- For ease of explanation, the relationships between the SB-23 and various Nikon cameras are classified into six groups at right.
- Before using the SB-23, determine your Nikon camera group in the **Camera Group Table** shown at right.

## Nikon Camera Groups and TTL auto flash available with the SB-23

Camera name	Group	Type of TTL auto flash with the SB-23
F5 F90X/N90s* F90-series/N90* F70-series/N70*	I	<ul style="list-style-type: none"><li>• Multi-Sensor Balanced Fill-Flash</li><li>• Multi-Sensor Balanced Fill-Flash</li><li>• Center-Weighted Fill-Flash/Spot Fill-Flash</li><li>• Standard TTL Flash</li></ul>
F4-series F-801s/N8008s* F-801/N8008* PRONEA 600i/6i*	II	<ul style="list-style-type: none"><li>• Matrix Balanced Fill-Flash</li><li>• Center-Weighted Fill-Flash/Spot Fill-Flash</li><li>• Standard TTL Flash</li><li>• Standard TTL Flash</li></ul>
F-601/N6006* F601M/N6000	III	<ul style="list-style-type: none"><li>• Matrix Balanced Fill-Flash</li><li>• Center-Weighted Fill-Flash/Spot Fill-Flash</li><li>• Standard TTL Flash</li></ul>
F50-series/N50* F-401x/N5005*	IV	<ul style="list-style-type: none"><li>• Matrix Balanced Fill-Flash</li><li>• Center-Weighted Fill-Flash</li></ul>
F-501/N2020** F-401s/N4004s* F-401/N4004* F-301/N2000**	V	<ul style="list-style-type: none"><li>• Standard TTL Flash including Programmed TTL Auto Flash</li></ul>
FA, FE2, FG Nikonos V***	VI	<ul style="list-style-type: none"><li>• Standard TTL Flash</li></ul>

\* Sold exclusively in the U.S.A.

\*\* Sold exclusively in the U.S.A. and Canada.

\*\*\* Optional V-Type Sync Cord is necessary.

**ATTENTION:** The SB-23 will not operate with Nikon cameras other than those listed above.

# FLASH MODES AVAILABLE WITH SB-23

---

The SB-23 provides two flash modes, TTL auto and manual. In TTL auto flash mode, you can perform either Automatic Balanced Fill-Flash or Standard TTL Flash.

When using Standard TTL Flash control, the Speedlight tends to provide the main subject with more illumination than needed, resulting in an unnaturally bright subject with a dark background. With Automatic Balanced Fill-Flash, the flash output level is automatically compensated to create a natural balance between the overall exposure and the flash-illuminated subject.

Depending on the combination of camera you use with the SB-23, your metering system and exposure mode, the following may be available as Automatic Balanced Fill-Flash: Multi-Sensor Balanced Fill-Flash, Matrix Balanced Fill-Flash, Center-Weighted Fill-Flash and Spot Fill-Flash. In manual flash mode, the SB-23 fires at maximum output.

Standard TTL flash and manual flash mode are available with all of the Nikon camera groups.

## **Multi-Sensor Balanced Fill-Flash—with Group I cameras**

The camera's TTL Multi-Sensor analyzes brightness and contrast, automatically compensating the flash output level to balance the

flash output with ambient light.

This combination ensures a correct exposure even in difficult situations, including scenes with a highly reflective object such as a mirror or white wall, and scenes with a very dark background.

## **Matrix Balanced Fill-Flash—with Group II, Group III and Group IV cameras**

This combination enables you to take well-balanced photos with a correct exposure for both the background and foreground subject. When shooting scenes with a highly reflective object or a very dark background, however, there is a possibility of under- or overexposure.

## **Center-Weighted Fill-Flash/Spot Fill-Flash—with Group I, Group II, Group III and Group IV cameras**

With this combination, if you are using a lens without a CPU (any lens other than an AF Nikkor or AI-P-Nikkor), Center-Weighted Fill-Flash and Spot Fill-Flash will be performed as Automatic Balanced Fill-Flash instead of Multi-Sensor Balanced Fill-Flash or Matrix Balanced Fill-Flash. Flash output is properly compensated to produce a natural fill-flash effect.

## READ BEFORE USING

### **Nikkor lenses**

Nikon offers two types of Nikkor lenses—those with a built-in CPU and those without a built-in CPU.

#### **Nikkor lenses with a built-in CPU include:**

- D-type AF lenses
- Non-D-type AF Nikkor lenses except AF-Nikkor lenses for F3AF
- AI-P Nikkor lenses

#### **Nikkor lenses without a built-in CPU**

- Non-AF AI-S Nikkor lenses
- Nikon Series E lenses
- AI-modified Nikkor lenses and others

- Never fire the flash toward or near anyone's eyes; it may damage their retinas.
- Nikon cannot be responsible for malfunctions or other problems resulting from the use of other manufacturers' flash units, cameras or accessories, including lenses and external power sources.

### **For TTL multiple flash photography**

The SB-23 can be used only as a master flash unit, not as slave flash unit.

# NOMENCLATURE

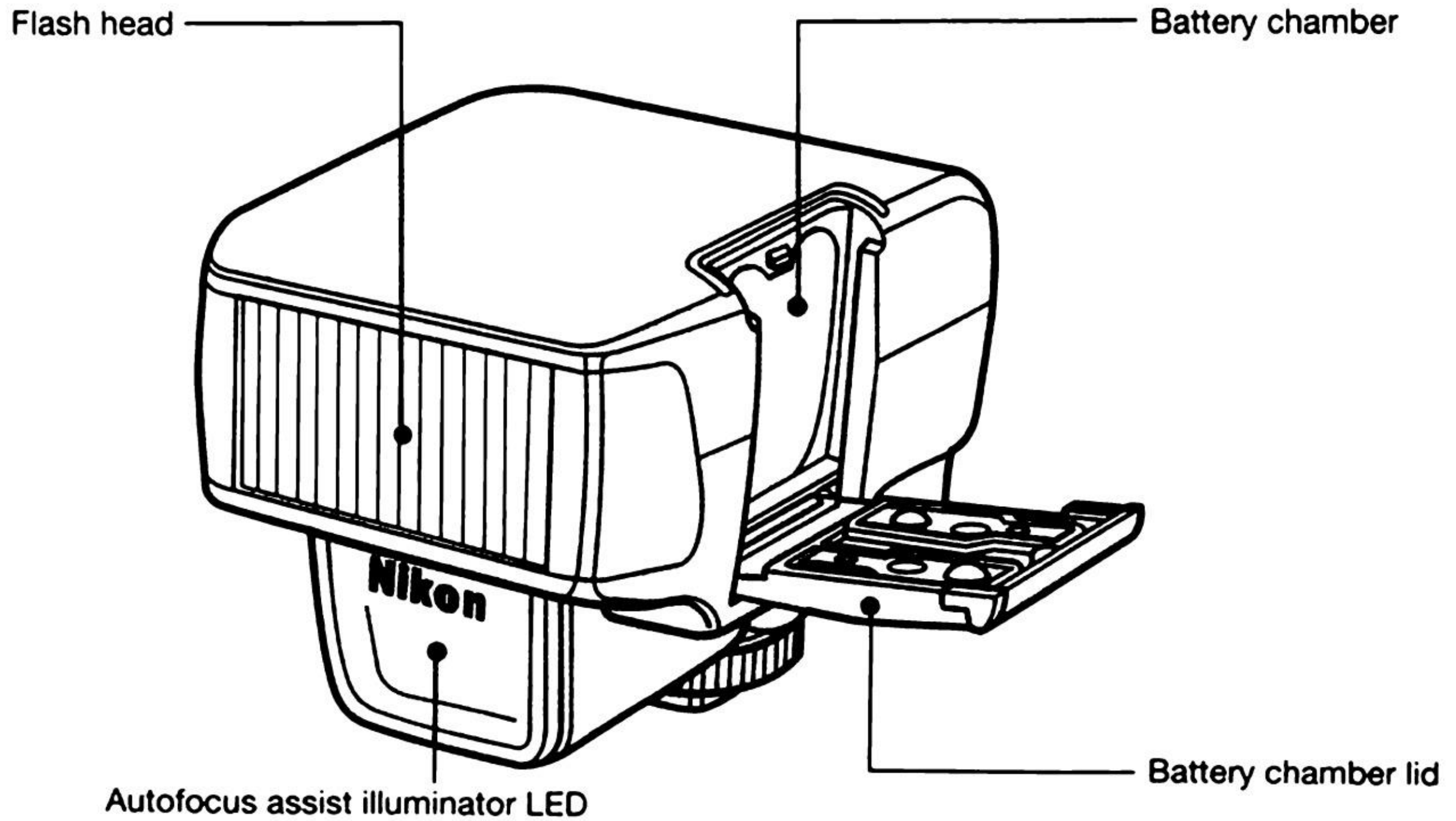

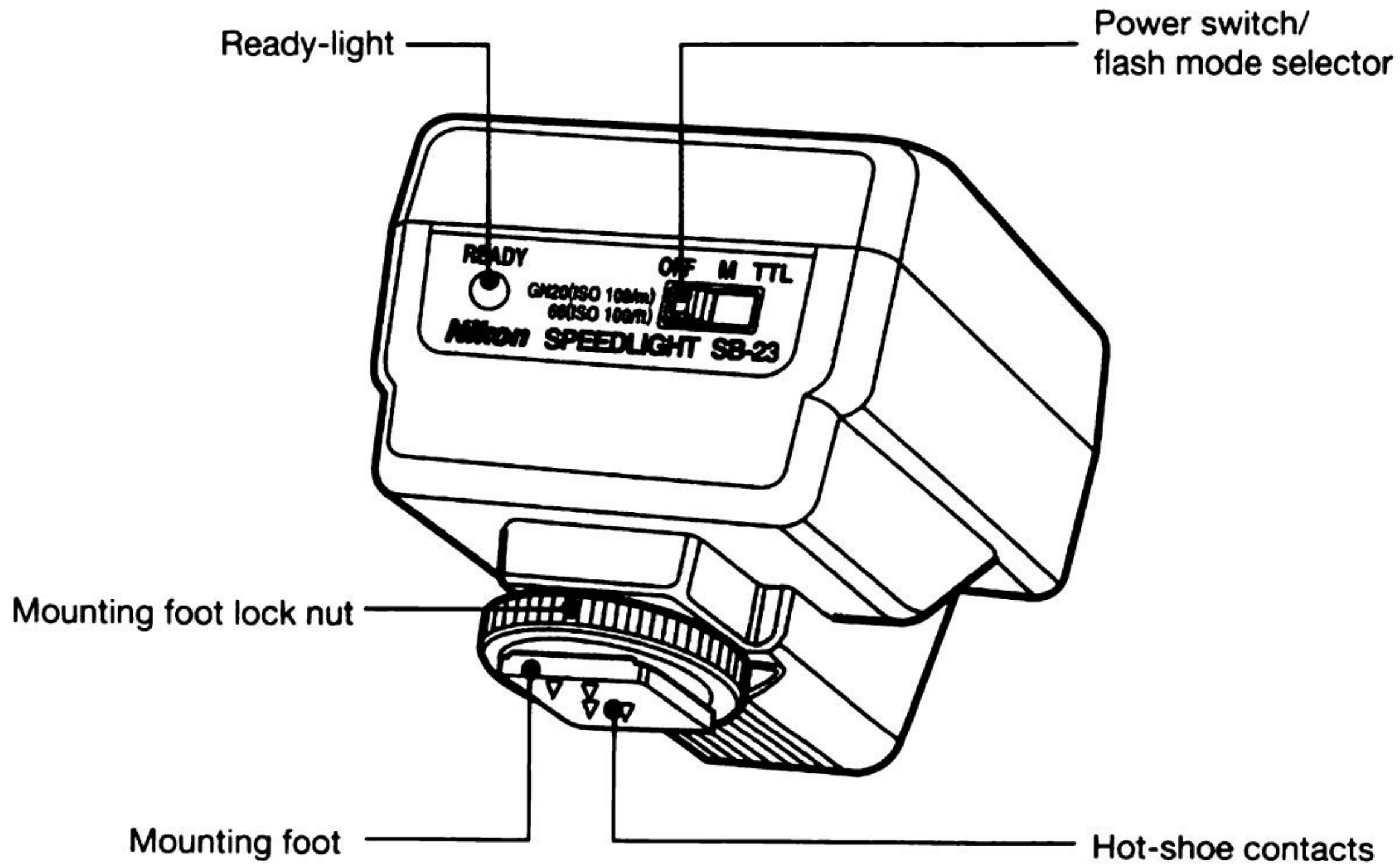

# CONTENTS

---

<b>FOREWORD</b> .....	2	<b>MANUAL FLASH OPERATION</b> .....	32
<b>FLASH MODES AVAILABLE WITH SB-23</b> .....	3-4	<b>CLOSE-UP FLASH PHOTOGRAPHY</b>	
<b>READ BEFORE USING</b> .....	4	<b>IN TTL AUTO FLASH MODE</b> .....	33
<b>NOMENCLATURE</b> .....	5-6	<b>MISCELLANEOUS</b> .....	34-41
<b>CONTENTS</b> .....	7	<b>AUTOFOCUS FLASH PHOTOGRAPHY</b> .....	34
<b>PREPARATION</b> .....	8-13	<b>IF THE UNDEREXPOSURE ALERT APPEARS INSIDE</b>	
<b>ATTACHING "APERTURE/ SHOOTING DISTANCE RANGE LABEL"</b> .....	8	<b>VIEWFINDER</b> .....	35
<b>INSTALLING BATTERIES</b> .....	8-9	<b>EXPOSURE COMPENSATION</b> .....	36
<b>ATTACHING FLASH UNIT</b> .....	10-11	<b>TROUBLESHOOTING</b> .....	37
<b>READY-LIGHT INDICATIONS</b> .....	12	<b>TIPS ON SPEEDLIGHT CARE</b> .....	38-39
<b>TTL AUTO FLASH AND MANUAL FLASH OPERATION</b> .....	13	<b>ABOUT BATTERIES</b> .....	40
<b>SHOOTING IN TTL AUTO FLASH</b>		<b>SPECIFICATIONS</b> .....	41
<b>MODE</b> .....	14-31		
<b>TTL Auto Flash Operation with Group I cameras</b> .....	14-15		
<b>TTL Auto Flash Operation with Group II cameras</b> .....	16-18		
<b>TTL Auto Flash Operation with Group III cameras</b> .....	19-20		
<b>TTL Auto Flash Operation with Group IV cameras</b> .....	21-23		
<b>TTL Auto Flash Operation with Group V cameras</b> .....	24-27		
<b>TTL Auto Flash Operation with Group VI cameras</b> .....	28-29		
<b>Selecting Aperture</b> .....	30-31		

# **PREPARATION** (For all-group Nikon cameras listed on page 2.)

## **ATTACHING "APERTURE/SHOOTING DISTANCE RANGE LABEL"**

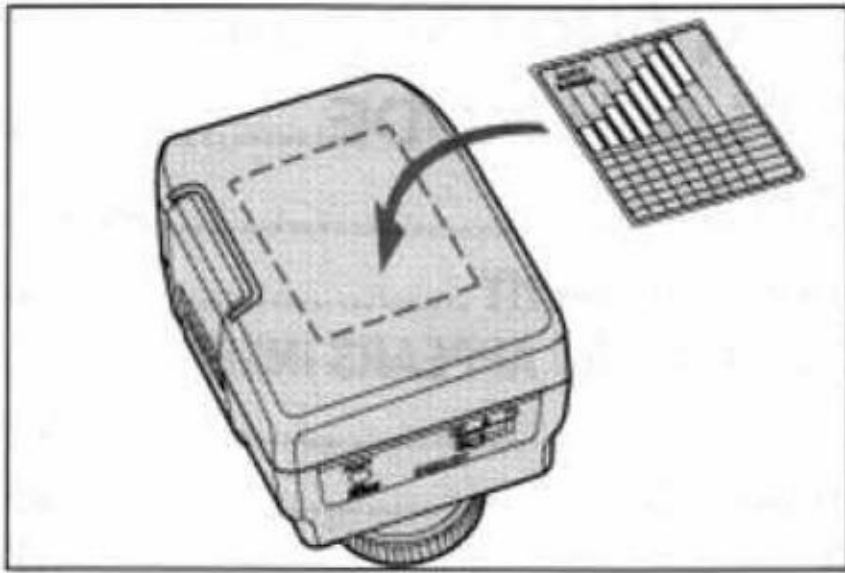

Two aperture/shooting distance range labels are provided—one in meters, the other in feet. Choose your desired label, and attach it to the Speedlight body.

## **INSTALLING BATTERIES**

**The following battery types can be used with the SB-23.**

- 1.5 V AA alkaline-manganese
- NiCd batteries
- Manganese batteries

Be sure to follow the "+" and "-" indications inside the battery chamber to ensure batteries are properly loaded.

For battery information, see "ABOUT BATTERIES" on page 40.

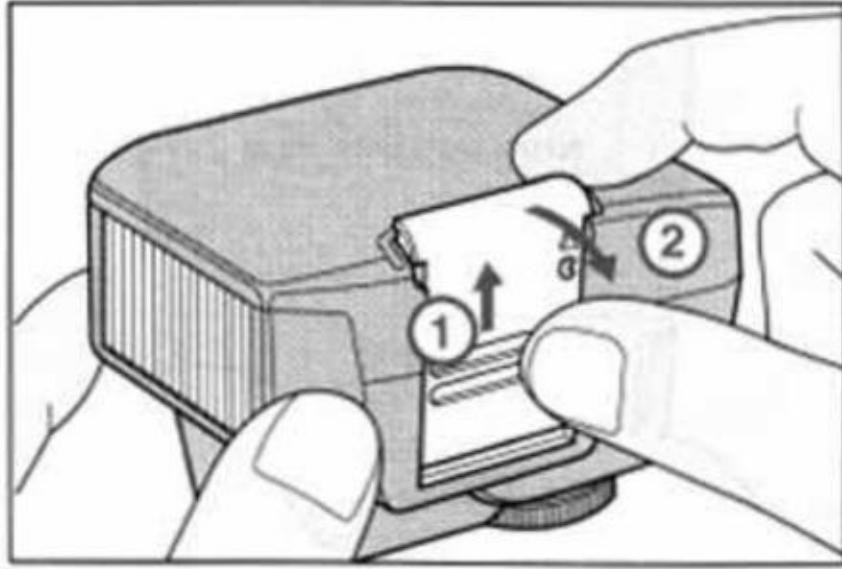

**1** Slide open the battery chamber lid.

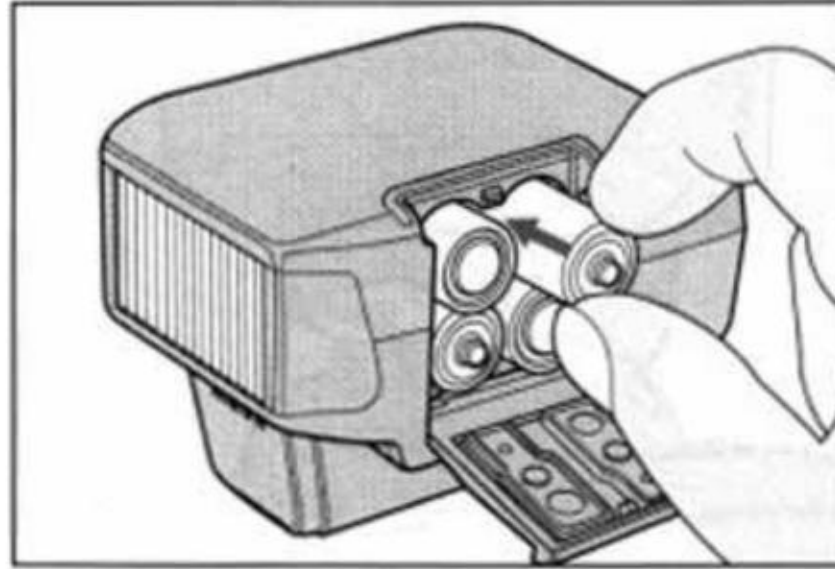

**2** Load four batteries into the battery chamber.

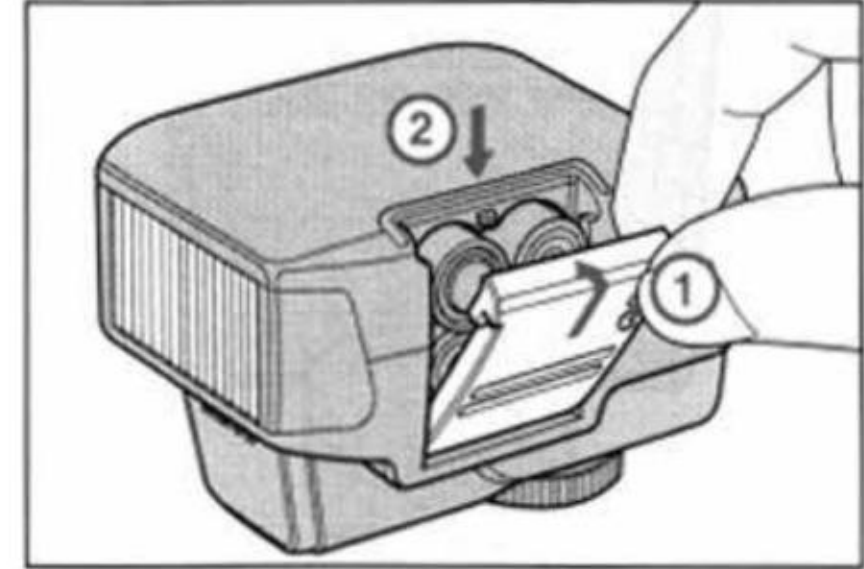

**3** Close the battery chamber lid.

- Batteries with a “+” terminal exceeding 6mm in diameter cannot be used.

## ATTACHING FLASH UNIT



- 1** Turn the mounting foot lock nut of the SB-23 clockwise as far as it goes.

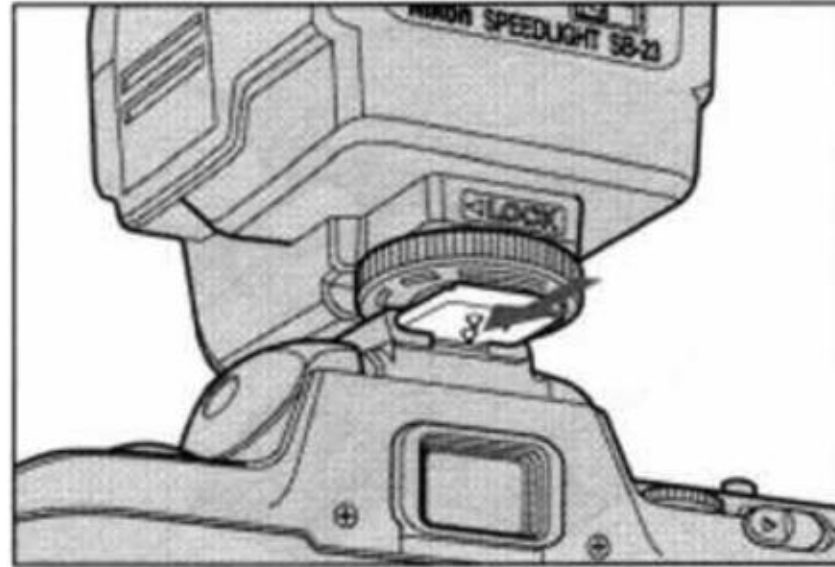

- 2** Slide the mounting foot forward into the camera's accessory shoe as far as it goes.
  - Power switches of the SB-23 and camera must be turned off.



- 3** Tighten the mounting lock nut firmly.

### **About the SB-23's standby system**

Setting the SB-23's power switch/flash mode selector to TTL or M position turns on the SB-23. At either of these positions, the SB-23 automatically turns off approx. 80 seconds after the SB-23 is used to conserve battery energy. To turn the SB-23 on again, lightly press the camera's shutter release button .

The standby system does not function in the following cases.

**FA, FE2:** When you have selected a mechanical shutter setting of "M250" or "B," or when using the Nikon Motor Drive MD-12.

**FG, Nikonos V:** When the shutter speed dial is set to "M90" or B.

### **Caution:**

When not using the SB-23 or when carrying it in a bag, etc., always set the power switch/flash mode selector to OFF position.

## READY-LIGHT INDICATIONS



The SB-23's ready-light lights up or blinks in the following cases.

### **The ready-light comes on—flash is ready to fire**

With the SB-23's flash mode selector at TTL or M, the ready-light lights up to indicate the flash is ready to fire.

Flash shooting is possible whenever the ready-light lights up.

### **Both viewfinder ready-light and SB-23's ready-light blink for a few seconds after shooting—light output might be insufficient**

With the SB-23 in TTL auto flash mode, if both the camera's viewfinder ready-light and SB-23's ready-light blink for a few seconds after shooting, the flash has fired at its maximum output and light might be insufficient for correct

exposure. Check aperture/shooting distance range table on the SB-23 to determine whether you were beyond the indicated maximum range. Depending on conditions, choose a wider aperture for maximum flash range (if exposure mode is set at Programmed or Shutter-Priority Auto, switch to Aperture-Priority Auto or Manual ), or move closer to the subject.

### **Notes:**

- If the ready-light takes more than 30 sec. to light up when using alkaline-manganese batteries, replace with a fresh set.
- With NiCd batteries, if recycling time is over 10 seconds, recharge them.

# TTL AUTO FLASH AND MANUAL FLASH OPERATION

---

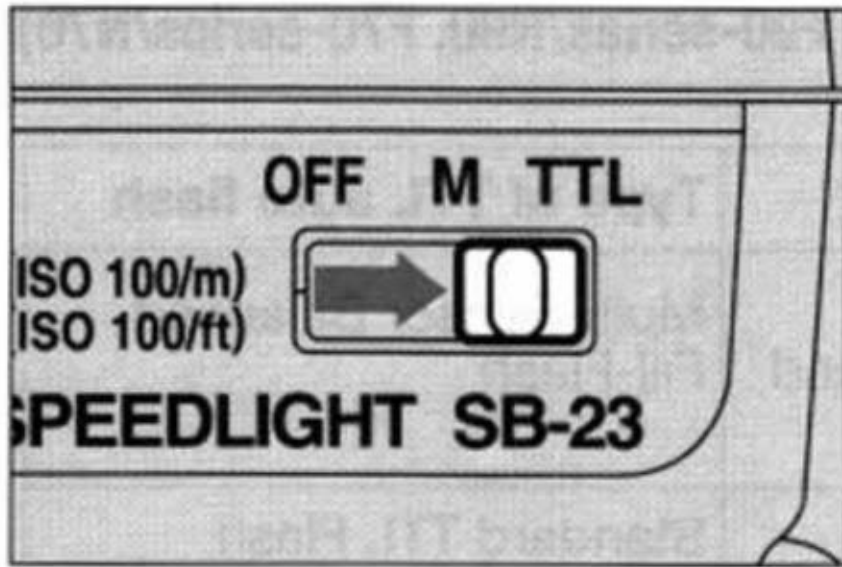

To turn on the SB-23, set the power switch/flash mode selector to TTL or M position. For TTL auto flash, set to TTL; for Manual flash, set to M.

**For TTL Auto flash operation see pages 14 to 31.**

<b>With Group I cameras</b>	<b>see pages 14 to 15.</b>
<b>With Group II cameras</b>	<b>see pages 16 to 18.</b>
<b>With Group III cameras</b>	<b>see pages 19 to 20.</b>
<b>With Group IV cameras</b>	<b>see pages 21 to 23.</b>
<b>With Group V cameras</b>	<b>see pages 24 to 27.</b>
<b>With Group VI cameras</b>	<b>see pages 28 to 29.</b>

**For Manual flash operation with all cameras, see page 32.**

# SHOOTING IN TTL AUTO FLASH MODE

TTL Auto Flash Operation with Group I cameras (F5, F90X/N90s, F90-series/N90, F70-series/N70)

Lens	Metering system	Exposure mode	Type of TTL auto flash	
<b>Nikkor lenses with a built-in CPU</b>	Matrix	Programmed Auto, Shutter-Priority Auto and Aperture-Priority Auto	Multi-Sensor Balanced Fill-Flash	
		Manual	Standard TTL Flash	
	Center-Weighted	Programmed Auto, Shutter-Priority Auto and Aperture-Priority Auto	Center-Weighted Fill-Flash	
		Manual	Standard TTL Flash	
	Spot	Programmed Auto, Shutter-Priority Auto and Aperture-Priority Auto	Standard TTL Flash with F5 or Multi-Sensor Balanced Fill-Flash with other cameras	
		Manual	Standard TTL Flash	
	<b>Other lenses</b>	Matrix/Center-Weighted/Spot	Aperture-Priority/Manual	Standard TTL Flash

*In Programmed Auto exposure and Shutter-Priority Auto modes, always set the SB-23's flash mode to TTL. At M, the camera's shutter is locked (except F5).*

## Procedure

- 1. Set the SB-23's power switch/flash mode selector to TTL to turn on the SB-23.**
- 2. Set the camera's sync mode to normal sync.**
- 3. Select aperture.**

In Programmed or Shutter-Priority Auto exposure mode, set the lens to its minimum aperture (largest f-number).  
In Aperture-Priority Auto or Manual exposure mode, set the aperture so the subject is positioned within the flash shooting distance range. (For flash shooting range, see page 30.)
- 4. Lightly press the shutter release button and confirm focus and exposure indications inside the viewfinder.**

For viewfinder exposure alerts, see page 35.
- 5. Confirm the SB-23's ready-light lights up, then fully depress the shutter release button to take a picture.**

**For 1/300 TTL High-Speed Sync with F5**  
Maximum flash shooting distance cannot be read from the flash shooting distance range table. To obtain maximum flash shooting distance in 1/300 TTL High-Speed Sync:

$$\text{flash-to-subject distance} = \frac{\text{guide number}}{\text{f/stop}}$$

Guide number at ISO 100 in TTL High-Speed Sync is approx. 14 (m) or approx. 46 (ft).  
To estimate guide number for film sensitivity other than ISO 100, multiply the following coefficient to 14 (m) or 46 (ft).

ISO number	25	50	200	400	800
Coefficient	0.5	0.71	1.4	2	2.8

**TTL Auto Flash Operation with Group II cameras (F4-series, F-801s/N8008s, F-801/N8008, PRONEA 600i/6i)  
With F4-series cameras**

<b>Lens</b>	<b>Metering system</b>	<b>Exposure mode</b>	<b>Type of TTL auto flash</b>	
<b>AF Nikkor lenses/ AI-P type Nikkor lenses/ AF Teleconverter/ AF-Nikkor lenses for Nikon F3 AF/AI-type Nikon and Nikkor lenses (including AI-S)</b>	Matrix	Programmed Auto, Shutter-Priority Auto and Aperture-Priority Auto	Matrix Balanced Fill-Flash	
		Manual	Standard TTL Flash	
	Center-Weighted	Programmed Auto, Shutter-Priority Auto and Aperture-Priority Auto	Center-Weighted Fill-Flash	
		Manual	Standard TTL Flash	
	Spot	Programmed Auto, Shutter-Priority Auto and Aperture-Priority Auto	Standard TTL Flash	
		Manual	Standard TTL Flash	
	<b>Other lenses</b>	Matrix/Center- Weighted/Spot	Aperture-Priority/Manual	Standard TTL Flash

**With F-801s/N8008s, F-801/N8008 and PRONEA 600i/6i cameras**

<b>Lens</b>	<b>Metering system</b>	<b>Exposure mode</b>	<b>Type of TTL auto flash</b>
<b>AF Nikkor lenses/ AI-P type Nikkor lenses</b>	<b>Matrix</b>	Programmed Auto* <sup>1</sup> , Shutter-Priority Auto and Aperture-Priority Auto	Matrix Balanced Fill-Flash
		Manual	Standard TTL Flash
	<b>Center-Weighted</b>	Programmed Auto* <sup>1</sup> , Shutter-Priority Auto and Aperture-Priority Auto	Center-Weighted Fill-Flash
		Manual	Standard TTL Flash
	<b>Spot*<sup>2</sup></b>	Programmed Auto* <sup>1</sup> , Shutter-Priority Auto and Aperture-Priority Auto	Spot-Fill Flash
		Manual	Standard TTL Flash
<b>Other lenses</b>	<b>Center-Weighted/ Spot*<sup>2</sup></b>	Aperture-Priority	Center-Weighted Fill- Flash/Spot Fill-Flash
		Manual	Standard TTL Flash

\*<sup>1</sup> In Programmed Auto exposure mode, always set the SB-23's flash mode to TTL. At M, the camera's shutter locks.

\*<sup>2</sup> Spot Metering is not available with the F-801/N8008.

---

## Procedure for Group II cameras

**1.** Set the SB-23's power switch/flash mode selector to TTL to turn on the SB-23.

**2.** Select aperture.

In Programmed or Shutter-Priority Auto exposure mode, set the lens to its minimum aperture (largest f-number).











In Aperture-Priority Auto or Manual exposure mode, set the aperture so the subject is positioned within the flash shooting distance range. (For flash shooting range, see page 30.)

**3.** Lightly press the shutter release button to confirm focus and exposure indications inside the viewfinder.

For viewfinder exposure alerts, see page 35.

**4.** Confirm the SB-23's ready-light comes on, then fully depress the shutter release button to take a picture.

## TTL Auto Flash Operation with Group III cameras (F601/N6006, F601M/N6000)

Lens	Camera's setting			Indication on camera's LCD panel	Type of TTL auto flash
	Exposure mode	Metering system	Automatic Balanced Fill-Flash		
AF Nikkor lens with a built-in CPU	Programmed Auto, Shutter-Priority Auto, Aperture-Priority Auto or Manual	Matrix	Set		Matrix Balanced Fill-Flash
			Cancel		Standard TTL Flash
		Center-Weighted	Set		Center-Weighted Fill-Flash
			Cancel		Standard TTL Flash
		Spot	Set		Spot Fill-Flash
			Cancel		Standard TTL Flash
Other lenses	Aperture-Priority Auto or Manual	Center-Weighted	Set		Center-Weighted Fill-Flash
			Cancel		Standard TTL Flash
		Spot	Set		Spot Fill-Flash
			Cancel		Standard TTL Flash

---

## Procedure for Group III cameras

**1.** Set the SB-23's power switch/flash mode selector to TTL to turn on the SB-23.

**2.** Make sure that normal sync is set on the camera.

**3.** Select aperture.

In Programmed or Shutter-Priority Auto exposure mode, set the lens to its minimum aperture (largest f-number).

In Aperture-Priority Auto or Manual exposure mode, set the aperture so the subject is positioned within the flash shooting distance range. (For flash shooting range, see page 30.)

**4.** Lightly press the shutter release button and confirm focus and exposure indications inside the viewfinder. For viewfinder exposure alerts, see page 35.

**5.** Confirm that the SB-23's ready-light comes on, then fully depress the shutter release button to take a picture.

## TTL Auto Flash Operation with Group IV cameras (F50-series/N50, F401x/N5005)

Lens	Camera's exposure mode	Type of TTL auto flash
<b>Nikkor lens with a built-in CPU</b>	Programmed Auto* <sup>1</sup>	Matrix Balanced Fill-Flash
	Shutter-Priority Auto	
	Aperture-Priority Auto	
	<b>Other lenses</b>	Manual

\*<sup>1</sup> With an F50-series/N50 camera in Silhouette Program, Close-Up Program or Landscape Program, do not use the flash.

---

## Procedure for Group IV cameras

**1.** Set the SB-23's power switch/flash mode selector to TTL to turn on the SB-23.

**2.** Select aperture.

In Programmed or Shutter-Priority Auto exposure mode, set the lens to its minimum aperture (largest f-number). Confirm your subject is within the flash shooting distance range. To verify the controlled aperture, see the table on page 23. For the flash shooting range, see page 31.

In Aperture-Priority Auto or Manual exposure mode, set the aperture so the subject is positioned at a point within the flash shooting distance range. For flash shooting range, see page 30.

**3.** Lightly press the shutter release button and confirm focus and exposure indications inside the viewfinder. For viewfinder exposure alerts, see page 35.

**4.** Confirm the SB-23's ready-light lights up, then fully depress the shutter release button to take a picture.

**To verify controlled aperture**

**With F50-series/N50 cameras:** See the table below to verify the controlled aperture with ISO 100 film in SIMPLE mode. (In ADVANCED mode, the controlled aperture appears inside the viewfinder.)

<b>For outdoor subject(s) on a sunny day</b>	<b>f/8</b>
<b>For outdoor subject(s) on a cloudy day or in shadows</b>	<b>f/5.6</b>
<b>For indoor subject(s)</b>	<b>f/4</b>

**With F-401x/N5005 cameras:** See the table below to verify the controlled aperture with ISO 100 film.

<b>Shooting conditions</b>	<b>Controlled aperture</b>	<b>Shutter speed in Shutter-Priority Auto exposure</b>
<b>Scene that includes the sun</b>	<b>f/16</b>	<b>1/125 sec.</b>
<b>For outdoor subject(s) on a sunny day</b>	<b>f/8</b>	<b>1/125 sec.</b>
<b>For outdoor subject(s) on a cloudy day or in shadows</b>	<b>f/5.6</b>	<b>1/125 sec.</b>
<b>For indoor subject(s)</b>	<b>f/5.6</b>	<b>1/30 sec.</b>

**TTL Auto Flash Operation with Group V cameras**  
**With F-501/N2020 and F-301/N2000 cameras**

<b>Lens</b>	<b>Lens aperture ring</b>	<b>Shutter speed dial</b>	<b>Exposure mode</b>	<b>Type of TTL auto flash</b>
<b>Nikkor lenses with a built-in CPU/ AF-Nikkor lenses for F3AF/AI-type Nikkor and Nikon lenses (including AI-S type) Series E</b>	Minimum aperture	P/DUAL (for F-501 only) P, PHI	Programmed Auto	Programmed TTL Auto Flash*1
	Any desired aperture	A	Aperture-priority auto	Standard TTL Flash
		1/125 - 1 sec., B*2	Manual	
<b>Other lenses</b>	Any desired aperture	A	Aperture-priority auto	Standard TTL Flash
		1/125 - 1 sec., B*2	Manual	

\*1 In Programmed TTL Auto Flash shooting, flash output is controlled in the same manner as in Standard TTL Flash, but the controlled aperture is fixed at each ISO film speed.

\*2 With the shutter speed set at 1/250 sec. or faster, the camera automatically switches to 1/125 sec. as soon as the SB-23 is turned on.

---

## Procedure for F-501/N2020 and F-301/N2000 cameras

**1.** Set the SB-23's power switch/flash mode selector to TTL to turn on the SB-23.

**2.** Select aperture.

For Programmed TTL Auto Flash in Programmed Auto exposure mode, set the lens to its minimum aperture (largest f-number). In Programmed TTL Auto flash, the controlled apertures are fixed at each ISO film speed and the shooting distance range is always from 0.7m to 3.5m regardless of the film speed in use (see table on page 31). In Aperture-Priority Auto or Manual exposure mode, set the aperture so the subject is positioned within the flash shooting distance range. (For flash shooting range, see page 30.)

**3.** Lightly press the shutter release button and confirm focus and exposure indications inside the viewfinder. For viewfinder exposure alerts, see page 35.

**4.** Confirm the SB-23's ready-light comes on, then fully depress the shutter release button to take a picture.

## With F-401s/N4004s and F-401/N4004 cameras

Lens	Camera's setting (exposure mode)			Type of TTL auto flash
	Aperture dial	Shutter speed dial		
Nikkor lens with a built-in CPU *1	S	A	Programmed Auto	Programmed TTL Auto Flash shooting*3
		1/60 - 1 sec. *2	Shutter-Priority Auto	
	Any desired aperture	A	Aperture-Priority Auto	Standard TTL Flash
		1/60 - 1 sec. and B*4	Manual	
Other lenses *4	Not usable	1/60 - 1 sec. and B*4	Manual	

\*1 Set lens to its minimum aperture (largest f-number). To set your desired aperture, use the camera's aperture dial.

\*2 If the shutter speed is set at 1/125 sec. or faster, the camera automatically switches to 1/100 sec. as soon as the SB-23 is turned on.

\*3 In Programmed TTL Auto Flash shooting, flash output is controlled in the same manner as in Standard TTL Flash, but the controlled apertures are fixed at each ISO film speed.

\*4 Viewfinder exposure indicator LEDs do not appear. Use an external exposure meter, then set the exposure using the lens aperture ring and shutter speed dial. Ignore the aperture set on the camera's aperture dial.

---

## Procedure with F-401s/N4004s and F-401/N4004 cameras

**1.** Set the SB-23's power switch/flash mode selector to TTL.

**2.** Select aperture.

For Programmed TTL Auto Flash in Programmed Auto exposure mode or Shutter-Priority Auto exposure mode, set the lens to its minimum aperture (largest f-number). In Programmed TTL Auto flash, the shooting distance range is always from 0.7m to 3.5m, regardless of the film speed in use (see table on page 31).

In Aperture-Priority Auto or Manual exposure mode, set the aperture so the subject is positioned within the flash shooting distance range. (For flash shooting range, see page 30.)

**3.** Lightly press the shutter release button to confirm focus and exposure indications inside the viewfinder.

For viewfinder exposure alerts, see page 35.

**4.** Confirm the SB-23's ready-light comes on, then fully depress the shutter release button to take a picture.

## TTL Auto Flash Operation with Group VI cameras (FA, FE2, FG, Nikonos V)

Lens	Camera's exposure mode setting	Possible shooting
All Nikon and Nikkor lenses	Aperture-Priority Auto*1	Standard TTL Flash
	Manual*2	

\*1 With an FA camera set at Programmed Auto or Shutter-Priority Auto exposure mode, turning on the SB-23 automatically switches the camera to Aperture-Priority Auto. Shutter speed is fixed at 1/250 sec. With an FE2 camera, the shutter speed is fixed at 1/250 sec.

With an FG camera set at Programmed Auto exposure mode, turning on the SB-23 automatically switches the camera to Aperture-Priority Auto. Shutter speed is fixed at 1/90 sec.

With a Nikonos V camera, the shutter speed is fixed 1/90 sec.

\*2 Mechanical settings (M250, M90 and B) on the camera's shutter speed dial cannot be used with the SB-23.

---

## Procedure for Group VI cameras

- 1.** Set the SB-23's power switch/flash mode selector to TTL to turn on the SB-23.
- 2.** Set the camera's exposure mode to Aperture-Priority Auto or Manual.
- 3.** Check the subject-to-camera distance, confirm the appropriate aperture from the table on page 31, then set the aperture value on the lens aperture ring.
- 4.** Lightly press the shutter release button to confirm the focus and exposure indications inside the viewfinder.  
For viewfinder exposure alerts, see page 35.
- 5.** Confirm the SB-23's ready-light comes on, then fully depress the shutter release button to take a picture.



## Using guide number

To determine the correct aperture, use the following equation.

$$f/\text{stop} = \frac{\text{guide number}}{\text{flash-to-subject distance}}$$

See table to confirm the guide numbers for various film speeds.

Unit: m/ft.

ISO film speed	25	50	100	200	400	800
Guide number	10/33	14/46	20/66	28/92	40/131	56/184

- For guide number for 1/300 TTL High-Speed Sync with F5, see page 15.

## Usable apertures/shooting distance range in TTL mode

Unit: m (ft)

ISO film speed							Shooting distance range
1000*	800*	400	200	100	50	25	
2.8+ <sup>1</sup> / <sub>3</sub>	2.8	2	–	–	–	–	3.6-20 (12-65)
4+ <sup>1</sup> / <sub>3</sub>	4	2.8	2	–	–	–	2.5-14 (8.3-46)
5.6+ <sup>1</sup> / <sub>3</sub>	5.6	4	2.8	2	–	–	1.8-10 (5.8-32)
8+ <sup>1</sup> / <sub>3</sub>	8	5.6	4	2.8	2	–	1.3-7.0 (4.2-23)
11+ <sup>1</sup> / <sub>3</sub>	11	8	5.6	4	2.8	2	0.9-5.0 (2.9-16)
16+ <sup>1</sup> / <sub>3</sub>	16	11	8	5.6	4	2.8	0.7-3.5 (2.1-11)
22+ <sup>1</sup> / <sub>3</sub>	22	16	11	8	5.6	4	0.6-2.5 (2.0-8.2)
–	–	22	16	11	8	5.6	0.6-1.7 (2.0-5.7)
–	–	–	22	16	11	8	0.6-1.2 (2.0-4.1)
–	–	–	–	22	16	11	0.6-0.9 (2.0-2.8)

\* For cameras in groups I, II, III and IV, plus the F-501/N2020 and F-301/N2000.

- = Programmed TTL Auto Flash information for F-501/N2020, F-401s/N4004s, F-401/N4004 and F-301/N2000 cameras. With F-401s/N4004s or F-401/N4004, the usable film speed is ISO 25 to 400.

# **MANUAL FLASH OPERATION** (for all Nikon camera groups)

---

In manual flash mode, the SB-23 fires at its maximum light output regardless of the flash-to-subject distance. Use manual flash mode when you cannot obtain an appropriate exposure in TTL auto mode.

## **Procedure**

- 1. Set the camera's exposure mode to Aperture-Priority Auto or Manual.**
- 2. Set the SB-23's power switch/flash mode selector to M to turn on the SB-23.**
- 3. Select and set the aperture on the lens or camera body.**  
Confirm the appropriate aperture by referring to page 31.
- 4. Confirm that the SB-23's ready-light comes on, then fully depress the shutter release button to take a picture.**

# CLOSE-UP FLASH PHOTOGRAPHY IN TTL AUTO FLASH MODE (for all Nikon camera groups)

For flash shooting with a subject closer than 0.6 m, use optional Nikon TTL Remote Cord SC-17. (With the SB-23 directly mounted on the camera, light from the SB-23 cannot cover a subject closer than 0.6 m.)

- For F5 cameras with a DW-30/DW-31 finder or F4-series cameras with a DW-20/DW-21 finder, use Nikon TTL Remote Cord SC-24.

## Procedure

- 1. Remove the SB-23 from the camera speedlight mount. Connect the SB-23 and camera with the TTL Remote Cord.**
- 2. Set the camera's exposure mode to Aperture-Priority Auto or Manual.**
- 3. Adjust the SB-23's position so that light from the flash head covers the subject.**
- 4. Set the SB-23's power switch/flash mode selector to TTL to turn on the SB-23.**

- 5. Determine the aperture using the following equation, then set the camera's aperture to that value.**

$$f/\text{stop (aperture)} \geq \frac{A}{\text{flash-to-subject-distance}}$$

where A corresponds to the film in use according to the table below.

ISO film speed	25	50	100	200	400	800	1000
A	2.5	3.5	5	7.5	10	—	—

When using ISO 100 film and the flash-to-subject distance is 0.5 m, for example, divide 5 by 0.5 to get 10. That means you should use an aperture of f/10 or smaller (f/10 or larger f-number). Use the smallest aperture possible.

# MISCELLANEOUS

## AUTOFOCUS FLASH PHOTOGRAPHY (with Nikon AF cameras)

The SB-23's AF assist LED lets you perform autofocus flash photography in dim light or even total darkness with a Nikon AF camera and AF Nikkor lens.

When ambient light is insufficient for autofocus operation, the AF assist LED automatically turns on to start the operation and add contrast to dark subject(s), allowing the camera's autofocus system to function as though it were daytime.

If ambient light is sufficient for autofocus, the AF assist LED does not light up.

- **Autofocus distance range with the AF assist LED:**

Approx. 1m (3.3 ft.) to 5m (16.4 ft.) at 20°C or 68°F.

- **Usable lenses:**

With the F-501/N2020: AF Nikkor lenses from 35 mm to 105 mm

With other Nikon AF cameras: AF Nikkor lenses from 24 mm to 105 mm

### Procedure

- 1. Set the camera's AF mode to Single Servo AF.**
- 2. Confirm the SB-23's ready-light comes on.**
- 3. Lightly press the shutter release button and confirm the in-focus indicator appears in the viewfinder.**
  - If the in-focus indication does not appear, the subject is beyond the autofocus distance range; focus manually on the clear matte field.  
Do not use the autofocus lock function.
- 4. Fully depress the shutter release button to take a picture.**
  - If the SB-23's ready-light becomes darker or blinks, replace the batteries with a fresh set.

## **IF THE UNDEREXPOSURE ALERT APPEARS INSIDE VIEWFINDER (with all Nikon camera groups)**

Background will be underexposed. To get a correct exposure for the background, perform slow sync flash photography.

When performing slow sync, use a tripod to prevent camera shake.

### **With I and III group cameras**

In Programmed Auto or Aperture-Priority Auto exposure mode, set the camera's sync mode to Slow-Sync.

### **With other cameras**

1. Turn off the SB-23.
2. Set the camera's exposure mode to Shutter-Priority Auto or Manual.
3. Set the shutter speed (and aperture in Manual exposure mode) so that the background will be correctly exposed.
4. Set the SB-23's power switch/flash mode selector to TTL to turn on the SB-23. Check the shooting distance range, confirm that the ready-light comes on, then fully depress the shutter release button to take a shot.

## EXPOSURE COMPENSATION (with all Nikon camera groups)

To make your picture lighter or darker, use your camera's exposure compensation function. To make the picture lighter, use "+" compensation. To make it darker, use "-" compensation.

If your camera has no exposure compensation function:

- In Standard TTL Flash, the flash shooting distance range varies with the amount of exposure compensation. To confirm the compensated distance range, see the table at right, then check the film speed on the back of the SB-23. If you make +1 EV compensation with ISO 100 film, for example, read the flash shooting distance range at ISO 50 on the aperture/flash shooting distance table and set ISO 50.

Exposure compensation value Film speed in use	+2	+1	0	-1	-2
25			25	50	100
50		25	50	100	200
100	25	50	100	200	400
200	50	100	200	400	800
400	100	200	400	800	
800/1000	200	400	800		

 : Not possible; shoot on manual.

## TROUBLESHOOTING (common to all Nikon camera groups)

Trouble	Cause	Remedy
<b>Ready-light does not come on.</b>	Batteries are improperly installed.	Properly install batteries.
	Batteries are exhausted.	Replace batteries with fresh ones.
	Power switch/mode selector is set at OFF position.	Set to TTL or M position.
	SB-23 has automatically turned off due to the standby system.	Lightly press the shutter release button.
<b>Ready-light blinks after shooting*.</b>	SB-23 fired at its maximum output but the light might have been insufficient for a correct exposure.	Check shooting distance and, if necessary, move closer to subject or select a wider aperture.
<b>Ready-light takes more than 30 sec., to come on when using alkaline-manganese batteries.</b>	Battery is exhausted.	Replace batteries with fresh ones.
<b>Ready-light takes more than 10 sec. to light up when using NiCd batteries.</b>	Battery power is weak.	Recharge NiCd batteries.
<b>Shutter locks when ready-light lights up.</b>	Power switch/mode selector is set at M position in Programmed Auto or Shutter-Priority Auto exposure mode.	Set power switch/mode selector to TTL position, or select Aperture-Priority Auto or Manual exposure mode.

\* In TTL auto flash mode, the ready-light blinks before shooting in the following cases:

- 1) With V- and VI-group cameras, when the film speed setting is beyond the usable range.
- 2) With VI-group cameras, when a mechanical shutter speed setting (M250, M90 or B) is selected.

## TIPS ON SPEEDLIGHT CARE

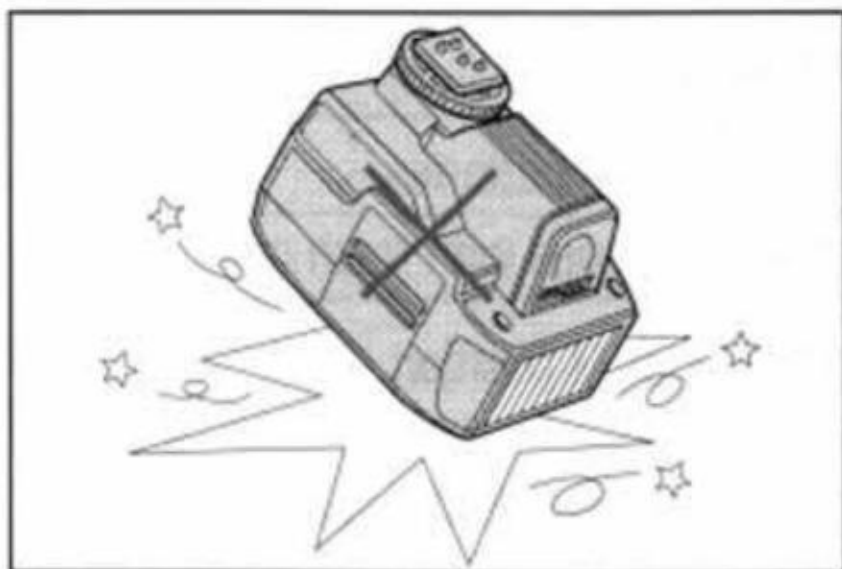

### **No strong shocks or vibration**

Never drop the SB-23 or allow strong shocks.

Strong shocks or vibration may affect the SB-23's precision alignment.

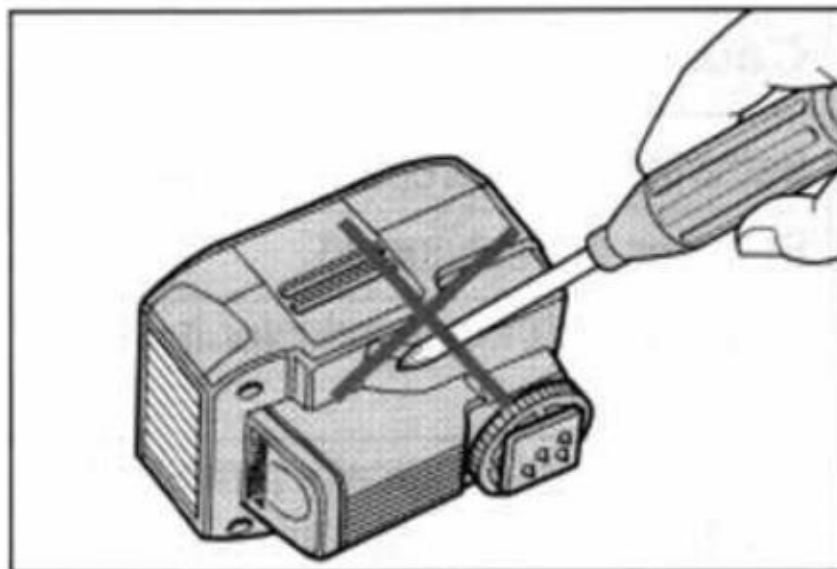

### **No disassembly**

The flash unit incorporates high-voltage circuits—never disassemble or repair it. If the SB-23 malfunctions or fails to work properly, take it immediately to an authorized Nikon dealer or service center.

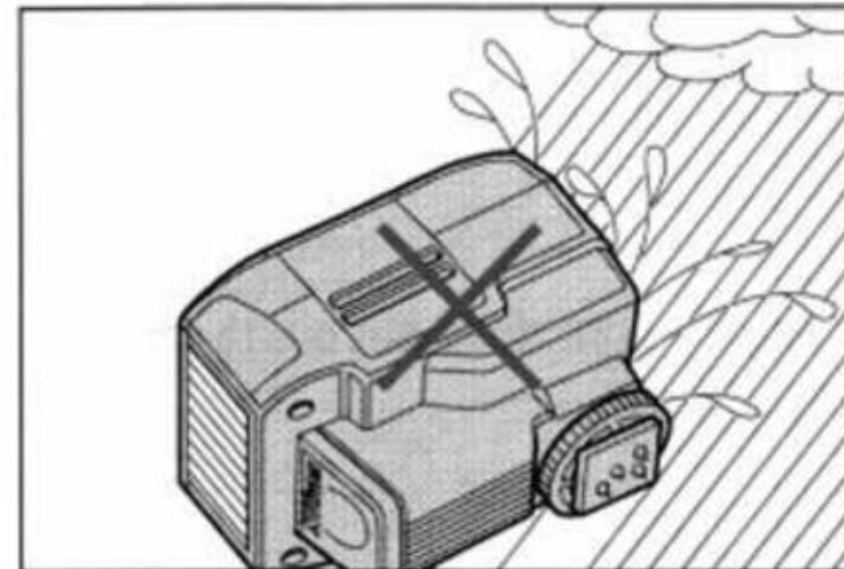

### **Keep the SB-23 away from water and out of the rain**

The SB-23 is not a waterproof flash unit—keep it away from water. If internal components are rusted by water, repair may not be possible.

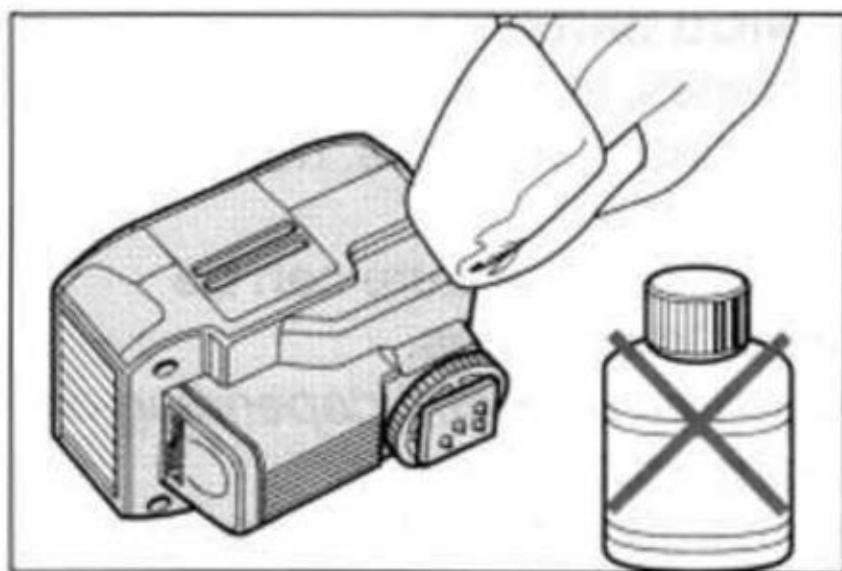

### **Cautions for cleaning**

To remove smudges, wipe with a soft, dry silicon-treated or regular cloth. Never use paint thinner, benzene, acetone, alcohol or chemical solvent cleaning agents—they might damage the plastic parts.

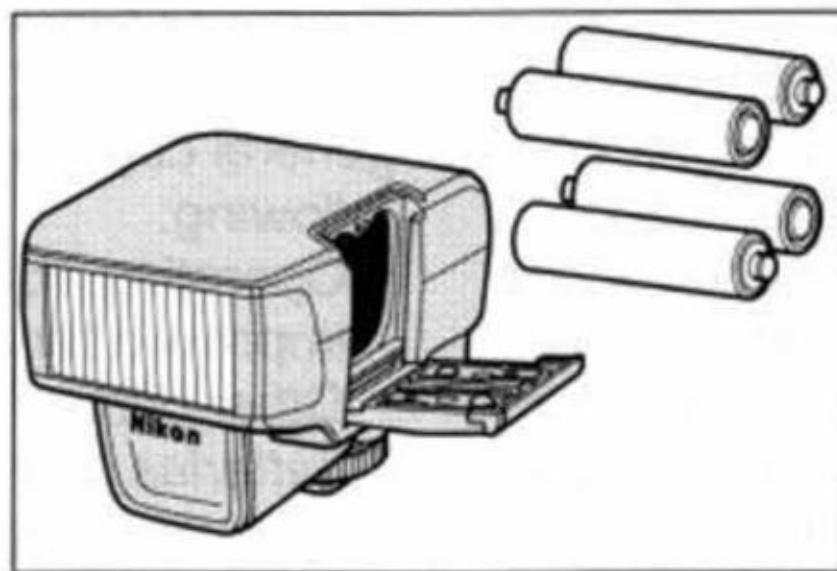

### **Cautions before storage**

When not using the SB-23, remove batteries to avoid damage due to battery leakage. If leakage occurs, take the SB-23 to your nearest authorized Nikon dealer.

To prevent deterioration of the condenser and prolong the life of your SB-23, load batteries and fire the SB-23 several times once per month.

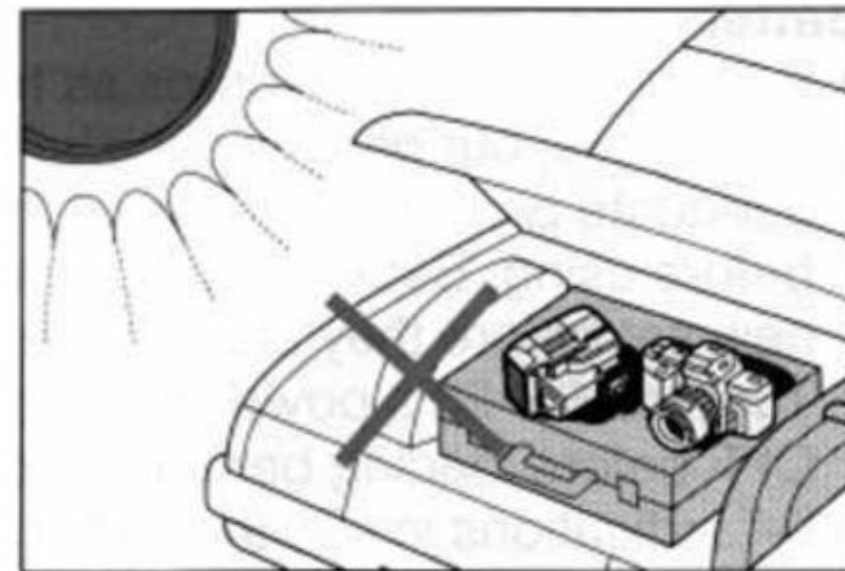

### **Cautions for storage**

Keep the SB-23 away from high temperatures and never store in a damp place. Store in a dry, well-ventilated location. Do not store the SB-23 together with naphthalene or camphor; do not place it near equipment that generates electromagnetic waves (television sets or radios); and keep it away from extremely hot places such as a car in summer or in front of a heater).

---

## **ABOUT BATTERIES**

### **Battery properties**

- Battery performance drops as temperature decreases, but performance will return after an adequate period of non-use. Check batteries before using. Batteries should be replaced with a new set before they are completely exhausted.
- Turn the SB-23's power/mode selector switch to OFF before loading batteries. Follow the "+" and "-" indications inside the battery chamber to ensure batteries are properly loaded.
- When replacing batteries, replace all old batteries with new ones. Never mix battery brands or models, or new and old batteries.  
*Improper usage may shorten battery life or cause a loss of contact.*
- Do not dispose of batteries by burning and never disassemble batteries.
- If you do not intend to use the SB-23 for a long period, remove the batteries from the SB-23 and store in a cool, dry place below 20°C(68°F).

### **Cautions for using NiCd batteries**

When using NiCd batteries, in addition to the general cautions for ordinary batteries, note the following:

- Operating ability at low temperature can be improved by using NiCd batteries.  
*Other battery data will be changed depending on batteries and charging status.*
- Batteries must be charged using the battery charger designated by the battery manufacturer.

## SPECIFICATIONS

**Electronic construction** Automatic silicon-controlled rectifier and series circuitry

**Power source** Four 1.5V AA-type alkaline-manganese, manganese or NiCd batteries

**Number of flashes and recycling time at manual full light output**

AA-type batteries	Number of flashes (approx.)*	Recycling time (approx.)*
Alkaline-manganese	400 times	2 sec.
Manganese	100 times	5 sec.
NiCd	150 times	1.5 sec.

*\* For autofocus operation with the AF-assist LED, fewer flashes are available and a longer recycling time is required.*

**Guide number (at ISO 100)**

20 (m) or 66 (ft) [or approx. 14 (m) or approx. 46 (ft) in 1/300 TTL High-Speed Sync]

**Angle of coverage**

Horizontal 60°, vertical 45°

**Usable lens** 35 mm or longer

**Power switch/ mode selector** Three positions are provided—OFF, TTL for TTL auto flash exposure control and M for manual flash exposure control

**Standby system** The SB-23 automatically turns off when it is not used for approx. 80 seconds, and turns on when camera's meter turns on

**Ready-light** Lights up when the flash is ready to fire; blinks for a few seconds after shooting when the SB-23 fired at its maximum output

**AF assist LED** Automatically fires LED beam toward the subject when performing autofocus with Nikon AF camera in insufficient light

**Dimensions (W x H x D)** Approx. 64 x 67 x 84 mm or 2.5 x 2.6 x 3.3 in.

**Weight (without batteries)**

Approx. 140 g or 4.9 oz.

**Accessories provided**

Soft Case SS-23

*All performance data are for normal-temperature operation (20°C/68°F).*

*Specifications and design are subject to change without notice.*