

SHARP SERVICE MANUAL

S24P132F540//

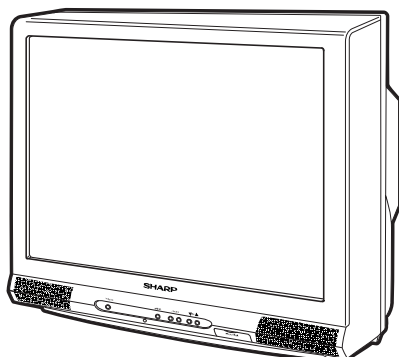

COLOR TELEVISION

Chassis No. GB-3U(1W)

MODEL 32F540

In the interests of user-safety (Required by safety regulations in some countries) the set should be restored to its original condition and only parts identical to those specified should be used.

CONTENTS

	Page
● ELECTRICAL SPECIFICATIONS	1
● IMPORTANT SERVICE SAFETY PRECAUTION	2
● LOCATION OF USER'S CONTROL	4
● INSTALLATION AND SERVICE INSTRUCTIONS	5
● SERVICE ADJUSTMENT	9
● CHASSIS LAYOUT	12
● BLOCK DIAGRAM	13
● DESCRIPTION OF SCHEMATIC DIAGRAMS & WAVEFORMS	14
● SCHEMATIC DIAGRAMS	15
● PRINTED WIRING BOARD ASSEMBLIES	24
● REPLACEMENT PARTS LIST	28
● PACKING OF THE SET	36

ELECTRICAL SPECIFICATIONS

POWER INPUT 120V AC, 60 Hz
 POWER RATING 150W
 PICTURE SIZE 3074 cm² (476sq inch)
 CONVERGENCE Magnetic
 SWEEP DEFLECTION Magnetic
 FOCUS Hi-Bi-Potential Electrostatic
 INTERMEDIATE FREQUENCIES
 Picture IF Carrier Frequency 45.75 MHz
 Sound IF Carrier Frequency 41.25 MHz
 Color Sub-Carrier Frequency 42.17 MHz
 (Nominal)

AUDIO POWER

OUTPUT RATING 5.0W + 5.0W (at 10% distortion and
 Dual CH Operate)

SPEAKER

SIZE 12 x 6 cm oval (2 pcs.)
 VOICE COIL IMPEDANCE 8 ohm at 400 Hz

ANTENNA INPUT IMPEDANCE

VHF/UHF 75 ohm Unbalanced

TUNING RANGES

VHF-Channels 2 thru 13
 UHF-Channels 14 thru 69
 CATV Channels 1 thru 125

(EIA, Channel Plan U.S.A.)

Specifications are subject to change without prior notice.

SHARP CORPORATION

This document has been published to be used for after sales service only.
 The contents are subject to change without notice.

IMPORTANT SERVICE SAFETY PRECAUTION

- Service work should be performed only by qualified service technicians who are thoroughly familiar with all safety checks and the servicing guidelines which follow:

WARNING

1. For continued safety, no modification of any circuit should be attempted.
2. Disconnect AC power before servicing.
3. Semiconductor heat sinks are potential shock hazards when the chassis is operating.
4. The chassis in this receiver has two ground systems which are separated by insulating material. The non-isolated (hot) ground system is for the B+ voltage regulator circuit. The isolated ground system is for the low B+ DC voltages and the secondary circuit of the high voltage transformer.
To prevent electrical shock use an isolation transformer between the line cord and power receptacle, when servicing this chassis.

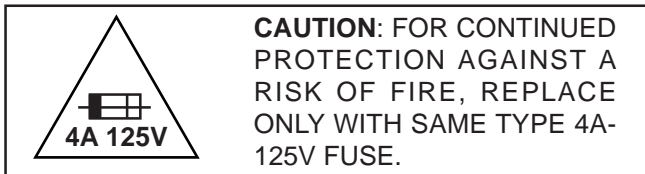

SERVICING OF HIGH VOLTAGE SYSTEM AND PICTURE TUBE

When servicing the high voltage system, remove the static charge by connecting a 10k ohm resistor in series with an insulated wire (such as a test probe) between the picture tube ground and the anode lead. (AC line cord should be disconnected from AC outlet.)

1. Picture tube in this receiver employs integral implosion protection.
2. Replace with tube of the same type number for continued safety.
3. Do not lift picture tube by the neck.
4. Handle the picture tube only when wearing shatterproof goggles and after discharging the high voltage anode completely.

X-RADIATION AND HIGH VOLTAGE LIMITS

1. Be sure all service personnel are aware of the procedures and instructions covering X-radiation. The only potential source of X-ray in current solid state TV receivers is the picture tube. However, the picture tube does not emit measurable X-Ray radiation, if the high voltage is as specified in the "High Voltage Check" instructions.
It is only when high voltage is excessive that X-radiation is capable of penetrating the shell of the picture tube including the lead in the glass material. The important precaution is to keep the high voltage below the maximum level specified.
2. It is essential that servicemen have available at all times an accurate high voltage meter.
The calibration of this meter should be checked periodically.
3. High voltage should always be kept at the rated value –no higher. Operation at higher voltages may cause a failure of the picture tube or high voltage circuitry and;also, under certain conditions, may produce radiation in exceeding of desirable levels.
4. When the high voltage regulator is operating properly there is no possibility of an X-radiation problem. Every time a color chassis is serviced, the brightness should be tested while monitoring the high voltage with a meter to be certain that the high voltage does not exceed the specified value and that it is regulating correctly.
5. Do not use a picture tube other than that specified or make unrecommended circuit modifications to the high voltage circuitry.
6. When trouble shooting and taking test measurements on a receiver with excessive high voltage, avoid being unnecessarily close to the receiver.
Do not operate the receiver longer than is necessary to locate the cause of excessive voltage.

IMPORTANT SERVICE SAFETY PRECAUTION

(Continued)

BEFORE RETURNING THE RECEIVER

(Fire & Shock Hazard)

Before returning the receiver to the user, perform the following safety checks.

1. Inspect all lead dress to make certain that leads are not pinched or that hardware is not lodged between the chassis and other metal parts in the receiver.
2. Inspect all protective devices such as non-metallic control knobs, insulating materials, cabinet backs, adjustment and compartment covers or shields, isolation resistor-capacity networks, mechanical insulators, etc.
3. To be sure that no shock hazard exists, check for leakage current in the following manner.
 - Plug the AC cord directly into a 120 volt AC outlet, (Do not use an isolation transformer for this test).
 - Using two clip leads, connect a 1.5k ohm, 10 watt resistor paralleled by a 0.15 μ F capacitor in series with all exposed metal cabinet parts and a known earth ground, such as electrical conduit or electrical ground connected to earth ground.
 - Use an AC voltmeter having with 5000 ohm per volt, or higher, sensitivity to measure the AC voltage drop across the resistor.

- Connect the resistor connection to all exposed metal parts having a return to the chassis (antenna, metal cabinet, screw heads, knobs and control shafts, escutcheon, etc.) and measure the AC voltage drop across the resistor.

All checks must be repeated with the AC line cord plug connection reversed. (If necessary, a non-polarized adapter plug must be used only for the purpose of completing these check.)

Any current measured must not exceed 0.5 milliamp. Any measurements not within the limits outlined above indicate of a potential shock hazard and corrective action must be taken before returning the instrument to the customer.

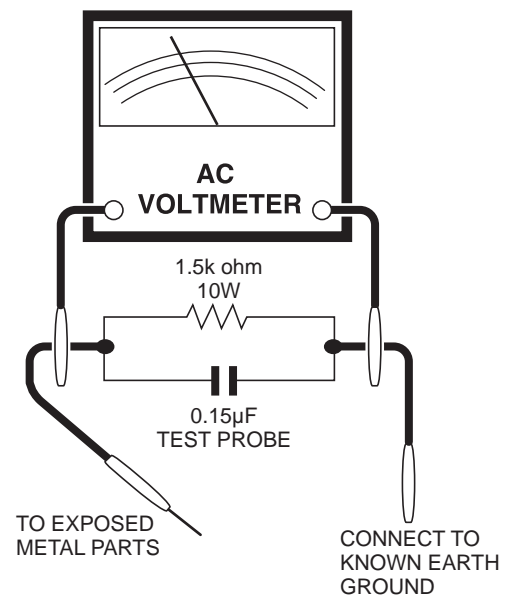

SAFETY NOTICE

Many electrical and mechanical parts in television receivers have special safety-related characteristics. These characteristics are often not evident from visual inspection, nor can protection afforded by them be necessarily increased by using replacement components rated for higher voltage, wattage, etc.

Replacement parts which have these special safety characteristics are identified in this manual; electrical components having such features are identified by " \triangle " and shaded areas in the Replacement Parts Lists and Schematic Diagrams.

For continued protection, replacement parts must be identical to those used in the original circuit. The use of substitute replacement parts which do not have the same safety characteristics as the factory recommended replacement parts shown in this service manual, may create shock, fire, X-radiation or other hazards.

LOCATION OF USER'S CONTROL

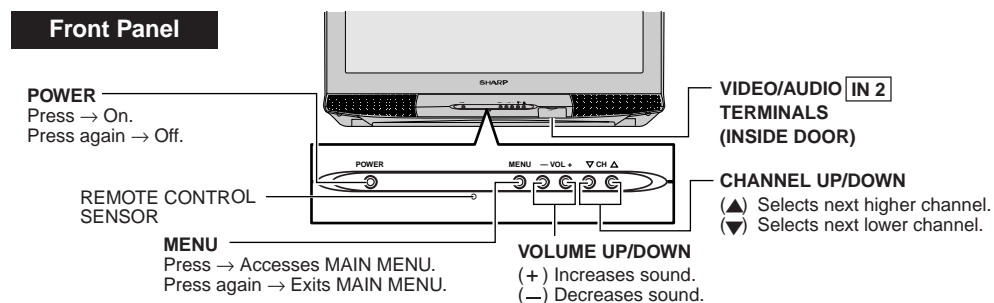

Basic Remote Control Functions

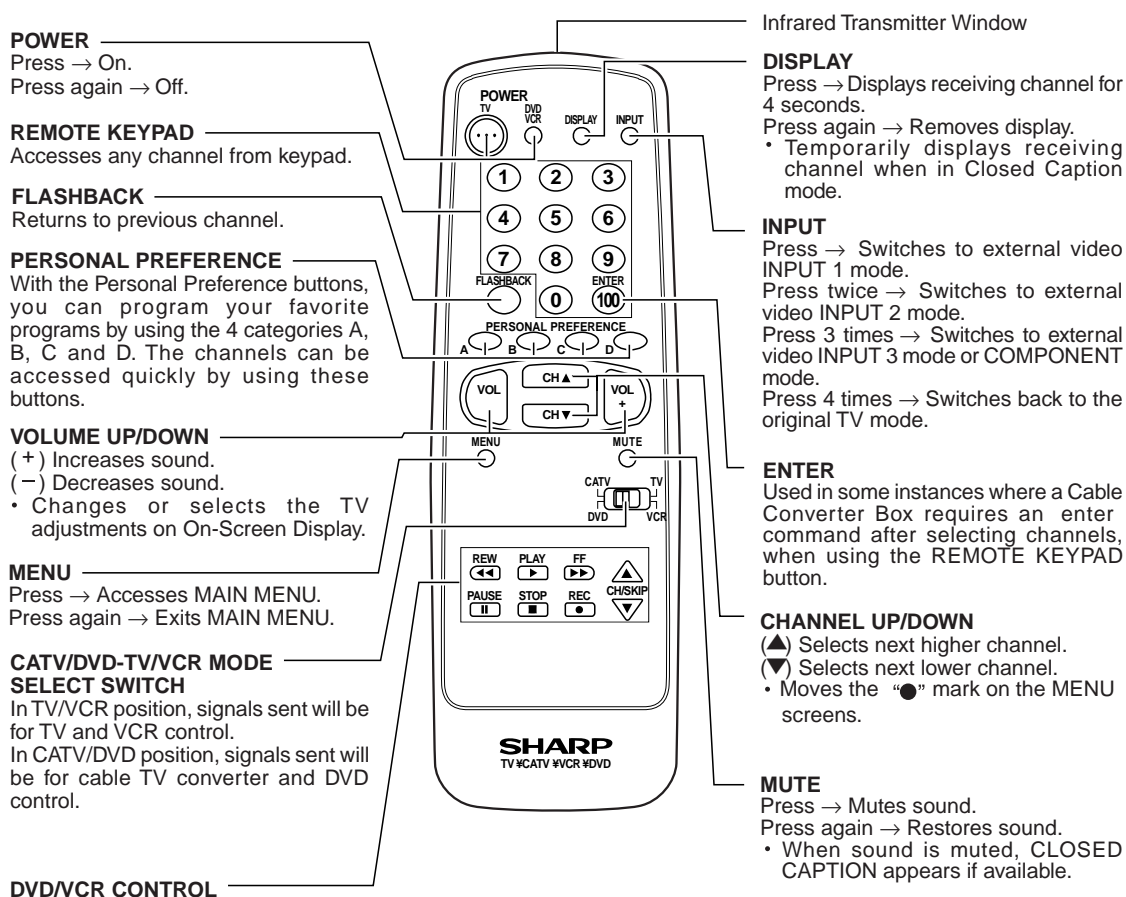

Note:

- The above shaded buttons on the Remote Control glow in the dark. To use the glow-in-the-dark display on the remote control, place it under a fluorescent light or other lighting.
- The phosphorescent material contains no radioactive or toxic material, so it is safe to use.
- The degree of illumination will vary depending on the strength of lighting used.
- The degree of illumination will decrease with time and depending on the temperature.
- The time needed to charge the phosphorescent display will vary depending on the surrounding lighting.
- Sunlight and fluorescent lighting are the most effective when charging the display.

INSTALLATION AND SERVICE INSTRUCTIONS

- Note:** (1) When performing any adjustments to resistor controls and transformers use non-metallic screwdrivers or TV alignment tools.
 (2) Before performing adjustments, the TV set must be on at least 15 minutes.

CIRCUIT PROTECTION

The receiver is protected by a 4.0A fuse (F701), mounted on PWB-A, wired into one side of the AC line input.

X-RADIATION PROTECTOR CIRCUIT TEST

After service has been performed on the horizontal deflection system, high voltage system, B+ system, test the X-Radiation protection circuit to ascertain proper operation as follows:

1. Apply 120V AC using a variac transformer for accurate input voltage.
2. Allow for warm up and adjust all customer controls for normal picture and sound.
3. Receive a good local channel.
4. Connect a digital voltmeter to TP653 (P651, Pin 3) and make sure that the voltmeter reads $13.7 \pm 0.6V$ DC.
5. Apply external 17.3V DC at TP653 by using an external DC supply, TV must be shut off.
6. To reset the protector, unplug the AC cord and plug the AC cord power on. Now make sure that normal picture appears on the screen.
7. If the operation of the horizontal oscillator does not stop in step 5, the circuit must be repaired before the set is returned to the customer.

HIGH VOLTAGE CHECK

High voltage is not adjustable but must be checked to verify that the receiver is operating within safe and efficient design limitations as specified checks should be as follows:

1. Connect an accurate high voltage meter between ground and anode of picture tube.
2. Operate receiver for at least 15 minutes at 120V AC line voltage, with a strong air signal or a properly tuned in test signal.
3. Enter the service mode and select the service adjustment "V11" and Bus data "01" (Y-mute on, CRT Cut Off).
4. The voltage should be below 35.0kV (at zero beam). If a correct reading cannot be obtained, check circuitry for malfunctioning components. After the voltage test, make Y-mute off to the normal mode.

For adjustments of this model, the bus data is converted to various analog signals by the D/A converter circuit.

Note: There are still a few analog adjustments in this series such as focus and master screen voltage. Follow the steps below whenever the service adjustment is required. See "Table-B" to determine, if service adjustments are required.

1. Service mode

Before putting unit into the service mode, check that customer adjustments are in the normal mode. Use the reset function in the video adjustment menu to ensure customer controls are in their proper (reset) position.

2. Service number selection

Once in the service mode, press the Ch-up or Ch-down button on the remote controller or at the set. The service adjustment number will vary in increments of one, from "V01" to "M05". Select the item you wish to adjust.

3. Data number selection

Press the Vol-up or Vol-down button to adjust the data number.

To enter the service mode and exit service mode.

To enter the service mode manually just press and hold the Vol-down and Ch-up buttons at the same time, plug the AC cord into a wall socket.

Now the TV set is switched on and enters the service mode.

To exit the service mode, turn the television off by pressing the power button.

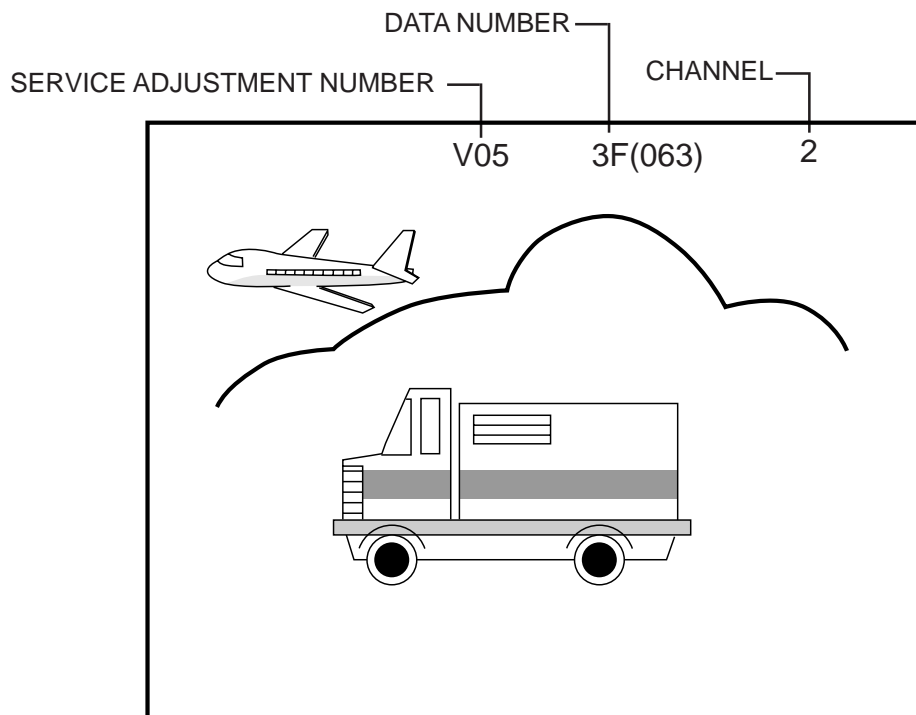

Figure A.

A. VCJ IC ADJUSTMENT

SERVICE NUMBER	ADJUSTMENT ITEM	DATA		NOTES	FIXED VALUE (HEX)
		RANGE	INITIAL VALUE		
V01	PICTURE	0-15 (00h-0Fh)	8 (08h)		
V02	TINT	0-127 (00h-7Fh)	66 (42h)		
V03	COLOR	0-127 (00h-7Fh)	56 (38h)		
V05	BRIGHT	0-127 (00h-7Fh)	64 (40h)		
V06	R CUT-OFF	64-255 (40h-FFh)	64 (40h)		
V07	G CUT-OFF	64-255 (40h-FFh)	64 (40h)		
V08	B CUT-OFF	64-255 (40h-FFh)	64 (40h)		
V09	G/R DRIVE	0-127 (00h-7Fh)	64 (40h)		
V10	B DRIVE	0-127 (00h-7Fh)	64 (40h)		
V11	Y-MUTE/V-STOP	0-2	0 (00h)	Y-Mute / Horizontal "—"	
V12	SHARP	0-63 (00h-3Fh)	50 (32h)		35
V13	DC RESTORATION	0-3 (00h-03h)	2 (02h)		02
V14	BLACK STRETCH	0-3 (00h-03h)	2 (02h)		02
V15	ABL START POINT	0-3 (00h-03h)	3 (03h)		03
V16	ABL GAIN	0-3 (00h-03h)	2 (02h)		02
V17	γ POINT	0-3 (00h-03h)	0 (00h)		00
V19	ENERGY SAVE	0-63 (00h-3Fh)	63 (3Fh)	Offset	3F
V24	LOW-G	0-255 (00h-FFh)	12 (0Ch)	Color Temp.	F4
V25	LOW-B	0-255 (00h-FFh)	241 (F1h)	Color Temp.	E6
V26	ML-G	0-255 (00h-FFh)	0 (00h)	Color Temp.	FD
V27	ML-B	0-255 (00h-FFh)	247 (F7h)	Color Temp.	F8
V28	HIGH-G	0-255 (00h-FFh)	2 (02h)	Color Temp.	01
V29	HIGH-B	0-255 (00h-FFh)	8 (08h)	Color Temp.	06
V30	WPL	0-1	1 (01h)		01
V31	RGB CONTRAST	0-63 (00h-3Fh)	59 (3Bh)		3B
V34	VSM GAIN	0-3 (00h-03h)	1 (01h)		01
V36	BPF/TOF-INPUT	0-1	0 (00h)	External Input	00
V37	CORING	0-1	0 (00h)		00
V38	VSM PHASE	0-1	0 (00h)		00
V39	COLOR γ	0-1	0 (00h)		00
V40	SHARP-INPUT	0-63 (00h-3Fh)	44 (2Ch)	External Input	2F
V41	TINT-INPUT	0-127 (00h-7Fh)	62 (3Eh)	External Input	3E
V42	PICTURE-COMPONENT	0-15 (00h-0Fh)	6 (06h)	Component Input	
V43	TINT-COMPONENT	0-127 (00h-7Fh)	62 (3Eh)	Component Input	3E
V44	COLOR-COMPONENT	0-127 (00h-7Fh)	72 (48h)	Component Input	48
V45	BRIGHT-COMPONENT	0-127 (00h-7Fh)	84 (54h)	Component Input	
V46	R CUT OFF-COMPONENT	64-255 (00h-FFh)	64 (40h)	Component Input	
V47	G CUT OFF-COMPONENT	64-255 (00h-FFh)	64 (40h)	Component Input	
V48	B CUT OFF-COMPONENT	64-255 (00h-FFh)	64 (40h)	Component Input	
V49	G/R DRIVE-COMPONENT	0-127 (00h-7Fh)	64 (40h)	Component Input	
V50	B DRIVE-COMPONENT	0-127 (00h-7Fh)	64 (40h)	Component Input	
V51	SHARP-COMPONENT	0-63 (00h-3Fh)	44 (2Ch)	Component Input	2F
V52	TINT-S	0-127 (00h-7Fh)	62 (3Eh)	Component Input	3E
V53	C-TRAP	0-1 (00h-01h)	0 (00h)		00
V59	AUTO FRESH	0-1 (00h-01h)	0 (00h)		00
V60	SHARP P F	0-1 (00h-01h)	1 (01h)		01
V61	CD MATRIX	0-3 (00h-03h)	2 (02h)		02
V62	B-Y ATT	0-1 (00h-01h)	0 (00h)		00
V63	R-Y ATT	0-1 (00h-01h)	0 (00h)		00
V64	CD MATRIX COMPONENT	0-3 (00h-03h)	0 (00h)	Component Input	00
V65	B-Y ATT-COMPONENT	0-1 (00h-01h)	0 (00h)	Component Input	00
V66	R-Y ATT-COMPONENT	0-1 (00h-01h)	0 (00h)	Component Input	00
V67	BUZZ	0-1 (00h-01h)	1 (01h)		01
V68	RGB ABCL	0-1 (00h-01h)	1 (01h)		01
V69	PICTURE-VCOMP	0-100 (00h-64h)	47 (2Fh)	16:9 Format (Offset)	2F
V70	COLOR-VCOMP	0-100 (00h-64h)	50 (32h)	16:9 Format (Offset)	32
V71	BRIGHT-VCOMP	0-100 (00h-64h)	51 (33h)	16:9 Format (Offset)	33
R01	RF-AGC	0-63 (00h-3Fh)	36 (24h)		
R03	RF-AGC REF	0-255 (00h-FFh)	170 (AAh)	Standard value for the self-adjustment	AA
D01	V POSITION	0-7 (00h-07h)	0 (00h)		00
D02	H POSITION	0-31 (00h-1Fh)	15 (0Fh)		
D03	V SIZE	0-127 (00h-7Fh)	89 (59h)		
D04	H SIZE	0-63 (00h-3Fh)	36 (24h)		
D05	V-LINEARITY	0-15 (00h-0Fh)	8 (08h)		
D06	V-S CORRECTION	0-15 (00h-0Fh)	12 (0Dh)		0D
D07	EW PARABOLA	0-63 (00h-3Fh)	43 (2Bh)		
D08	EW TRAPEZIUM	0-63 (00h-3Fh)	36 (24h)		
D10	AFC GAIN	0-3 (00h-03h)	2 (02h)		02
D11	V EHT	0-7 (00h-07h)	6 (06h)		06
D12	H EHT	0-7 (00h-07h)	6 (06h)		06
D13	EW CORNER	0-31 (00h-1Fh)	8(08h)		0B

SERVICE NUMBER	ADJUSTMENT ITEM	DATA		NOTES	FIXED VALUE (HEX)
		RANGE	INITIAL VALUE		
D14	EW CORNER BOTTOM	19-81 (13h-51h)	50 (32h)	Offset toward D13.	32
D15	NOISE DET LEVEL	0-3 (00h-03h)	0 (00h)		00
D18	V CENTERING	0-63 (00-3Fh)	36 (24h)		
D19	V-AGC	0-1 (00h-01h)	0 (00h)		00
D20	V POSITION-VCOMP	0-7 (00h-07h)	0 (00h)	16:9 Format	00
D21	H POSITION-VCOMP	0-31 (00h-1Fh)	15(0Fh)	16:9 Format	
D22	V SIZE-VCOMP	0-127 (00h-7Fh)	52(34h)	16:9 Format	
D23	H SIZE-VCOMP	0-63 (00h-3Fh)	36(24h)	16:9 Format	
D24	V-LINEARITY-VCOMP	0-15 (00h-0Fh)	8(08h)	16:9 Format	
D25	V-C CORRECTION-VCOMP	0-15 (00h-0Fh)	10(0Ah)	16:9 Format	0B
D26	EW PARABOLA-VCOMP	0-63 (00h-3Fh)	22(16h)	16:9 Format	
D27	EW TRAPEZIUM-VCOMP	0-63 (00h-3Fh)	35(23h)	16:9 Format	
D28	V EHT-VCOMP	0-7 (00h-07h)	6(06h)	16:9 Format	06
D29	H EHT-VCOMP	0-7 (00h-07h)	6(06h)	16:9 Format	06
D30	EW CORNER-VCOMP	0-31 (00h-1Fh)	12(0Ch)	16:9 Format	0C
D31	EW CORNER BOTTOM-VCOMP	19-81 (13h-51h)	50(32h)	Offset toward D30	32
D32	V BLK UPPER-VCOMP	0-3 (00h-03h)	2(02h)	16:9 Format	02
D33	V BLK LOWER-VCOMP	0-3 (00h-03h)	2(02h)	16:9 Format	02
D34	V CENTERING-VCOMP	0-63 (00h-3Fh)	36(24h)	16:9 Format	

B. SPECIAL SETTING

SERVICE NUMBER	ADJUSTMENT ITEM	DATA		NOTES	FIXED VALUE (HEX)
		RANGE	INITIAL VALUE		
EX1	FAO VOLUME	0-50 (00h-32h)	36 (24h)		24
EX2	CC-POSITION	0-127 (00h-7Fh)	27 (1Bh)		
EX3	INT	0-255 (00h-FFh)	122 (7Ah)	Interrupt period adjustment.	7A
EX4	A-ATT	0-127 (00h-7Fh)	90 (5Ah)		5A
EX5	TUNER data	0-3 (00h-03h)	0 (00h)		00
EX6	Think chip-Slice LEVEL	0-255 (00h-FFh)	54 (36h)		12
EX7	RLY DELAY TIME	0-255 (00h-FFh)	0 (00h)	For the power control	00
EX8	ADG ON TIME	0-255 (00h-FFh)	10 (0Ah)	For the power control	0A

C. OPTION SETTING

SERVICE NUMBER	ADJUSTMENT ITEM	DATA		NOTES	FIXED VALUE (HEX)
		RANGE	INITIAL VALUE		
OP1	OPTION1	0-255 (00h-FFh)	245 (F5h)		F5
OP2	OPTION2	0-255 (00h-FFh)	188 (BCh)		3C
OP3	OPTION3	0-255 (00h-FFh)	15 (0Fh)		8F

D. SOUND ADJUSTMENT

SERVICE NUMBER	ADJUSTMENT ITEM	DATA		NOTES	FIXED VALUE (HEX)
		RANGE	INITIAL VALUE		
M01	INPUT LEVEL	0-15 (00h-0Fh)	7 (07h)		
M02	MTS VCO	0-63 (00h-3Fh)	38 (26h)		
M03	FILTER	0-63 (00h-3Fh)	36 (24h)		
M04	WIDEBAND	0-63 (00h-3Fh)	28 (1Ch)		
M05	SPECTRAL	0-63 (00h-3Fh)	23 (17h)		

Holding down both the VOL-up and CH-up buttons on the TV set at service mode for more than 2 seconds will automatically write the above initial values into IC2101.

PART REPLACED	ADJUSTMENT		NOTES
	NECESSARY	UNNECESSARY	
IC2001		X	Data is stored in IC2101.
IC201	X		The adjustment is needed to compensate for characteristics of parts including IC201 and MTS level (M01).
IC2101	X		Holding down both the VOL-up and CH-up buttons on the TV set in the service mode for more than 2 seconds will automatically write the above initial values into IC2101 Then perform a complete adjustment.
CRT	X		Adjust items related to picture tube only.
IC3001	X		Adjust items related to MTS only (M01~M05).

SERVICE ADJUSTMENT

RF AGC Adjustment

1. Receive a good local channel.
2. Enter the service mode and select the service adjustment "R01".
3. Set the data value to point where no noise or beat appears.
4. Select another channel to confirm that no noise or beat appears.

Note 1 : You will have to come out of the service mode to select another channel.

Note 2 : Setting the data to "00" will produce a black raster.

Screen Adjustment

1. Receive a good local channel.
2. Enter the service mode and select the service adjustment "V03" and set the data value to "00" to set the color level to minimum. (Record original data code under adjustment "V03" before changing) You may skip this step, if you selected a B/W picture or monoscope pattern.
3. Select the service adjustment "V11" and adjust the data value to "01", this turn off the luminance signal (Y-mute).
4. Adjust the master screen control until the raster darkens to the point where raster is barely seen.
5. Adjust the service adjustments "V06" red, "V07" green and "V08" blue to obtain a good grey scale with normal whites at low brightness level.
6. Select the service adjustment "V11" and reset data to "00". Select the service adjustment "V03" and reset data to obtain normal color level.
7. For component input, the data value of "V46" red, "V47" green and "V48" blue is adjusted to follow the data value of "V06", "V07" and "V08" respectively.
8. Reset the master screen control to obtain normal brightness range.

White Balance Adjustment

1. Receive a good local channel.
2. Enter the service mode and select the service adjustment "V03" and set to "00" (minimum color)(Record original data code under adjustment "V03" before changing). "V03" does not have to be adjusted, if you selected a B/W picture or monoscope pattern.
3. Alternately adjust the service adjustment data of "V09" and "V10" until a good grey scale with normal whites is obtained. (RF Input)
4. For component input, the data value of "V49" and "V50" is adjusted to follow the data value of "V09" and "V10" respectively.
5. Select the service adjustment "V03" and reset data to obtain normal color level.

Sub-picture and Sub-Bright Adjustments

1. Receive the window pattern signal.
 - RF INPUT (TU51)
2. Get into service adjustment data "V01" and "V05" and set the luminance as shown in figure "A" and "B" as below respectively.
 - COMPONENT INPUT
3. Get in service adjustment data "V42" and "V45" and set the luminance as shown in figure "A" and "B" as below respectively.

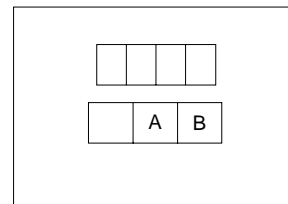

LUMINESCENCE CONFIRMATION

A: $95 \pm 10 \text{cd/m}^2$

B: $1.5 \pm 0.5 \text{cd/m}^2$

Sub-Tint Adjustment

1. Receive the half color bar signal.
- RF INPUT (TU51)
2. Get into Y-Mute by R/C, or by setting the "V11" bus data to "01".
3. Vary the "V02" bus data until the waveform becomes as stated below.

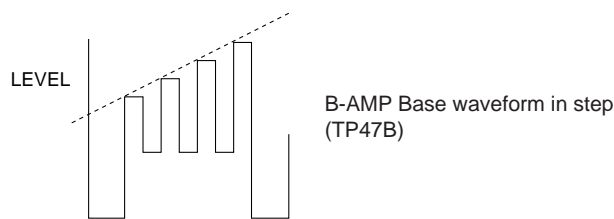

Sub-Color Adjustment

1. Receive a good local channel.
2. Make sure the customer color control is set to center position .
- RF INPUT (TU51)
3. Enter the service mode and select service adjustment "V03".
4. Adjust "V03" data value to obtain a normal color level.

Focus Adjustment

1. Receive a good local channel.
2. Adjust the FOCUS VR of the flyback transformer to make the image as fine as possible.

C. C Display Position Adjustment

1. Receive the lion head pattern signal.
2. Select "EX2" to display the text box.
3. Adjust the "EX2" bus data to let the text box displayed in the center.

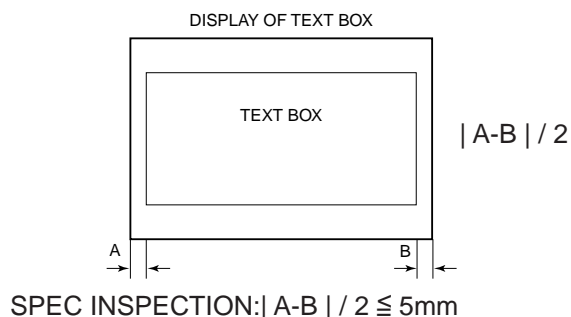

Vertical-Size and Linearity Adjustments

1. Receive a good local channel.
(SCREEN FORMAT 4:3)
2. Enter the service mode and select the service adjustment "D03" for V-size.
3. Adjust the "D03" bus data to get the proper V-size.
4. For V-linearity adjustment, select data bus "D05" and adjust to get the proper vertical linearity.
(SCREEN FORMAT 16:9 32F540 ONLY)
5. Input data of "D22" to mines 36 step from "D03" data.
(V-SIZE)
6. Input data of "D24" same as "D05" data. (V-LIN)

Note: Aging for 10 min before adjustment. After the adjustment of V-center and V-size, re-adjustment for this V-line.

Vertical Phase Adjustment

(SCREEN FORMAT 4:3)

1. Enter the service mode and input data of "00h" on "D01".
2. Adjust "D18" data value so that picture is centered.
(SCREEN FORMAT 16:9 32F540 ONLY)
3. Input data of "00h" on "D20".
4. Input data of "D34" same as "D18" data.

Horizontal Position Adjustment

(SCREEN FORMAT 4:3)

2. Enter the service mode and select the service adjustment "D02".
3. Adjust "D02" data value so that picture is centered.
(SCREEN FORMAT 16:9 32F540 ONLY)
4. Input data of "D21" same as "D02" data.

Horizontal-Size Adjustment

(SCREEN FORMAT 4:3)

2. Enter the service mode and select the service adjustment "D04" for H-size.
3. Adjust the "D04" bus data to get the proper H-size.
(SCREEN FORMAT 16:9 32F540 ONLY)
4. Input data of "D23" same as "D04" data.

EW-Parabola

(SCREEN FORMAT 4:3)

2. Enter the service mode and select the service adjustment "D07" for EW parabola.
3. Adjust the "D07" bus data to get the proper vertical straight line for both left and right side.
(SCREEN FORMAT 16:9 32F540 ONLY)
4. Input data of "D26" to mines 19 step from "D07" data.

EW-Trapezium

(SCREEN FORMAT 4:3)

2. Enter the service mode and select the service adjustment "D08" for EW-Trapezium.
3. Adjust the "D08" bus data to get the best position display.
(SCREEN FORMAT 16:9 32F540 ONLY)
4. Input data of "D27" same as "D08" data.

■ MTS ADJUSTMENT

MTS Level Adjustment

1. Set the sound volume above 1.
Monoral signal: 400Hz, 100% modulation
2. Confirm "EX4" data is "5Ah".
3. Vary the "M01" bus data until the voltage to pin (39) of IC3001 to become the value as stated below.

SETTING VOLTAGE

ADJ spec : 490 ± 10 mVrms

CHK spec: 490 ± 20 mVrms

Separation Adjustment

1. Input "SIGNAL 1" and vary the "M04" bus data to get the minimum AC voltage to pin (39) of IC3001.
2. Input "SIGNAL 2" and vary the "M05" bus data to get the minimum AC voltage to pin (39) of IC3001.

SIGNAL 1: 300Hz, 30% modulation, Lch only, NR-ON

SIGNAL 2: 3kHz, 30% modulation, Lch only, NR-ON

Note: SIGNAL 1 Adj. for wideband

SIGNAL 2 Adj. for spectral

Check the output of the speaker at the maximum volume as stated below.

Confirmation spec:

ADJ spec: above 25 dB

CHK spec: above 20 dB

BLOCK DIAGRAM

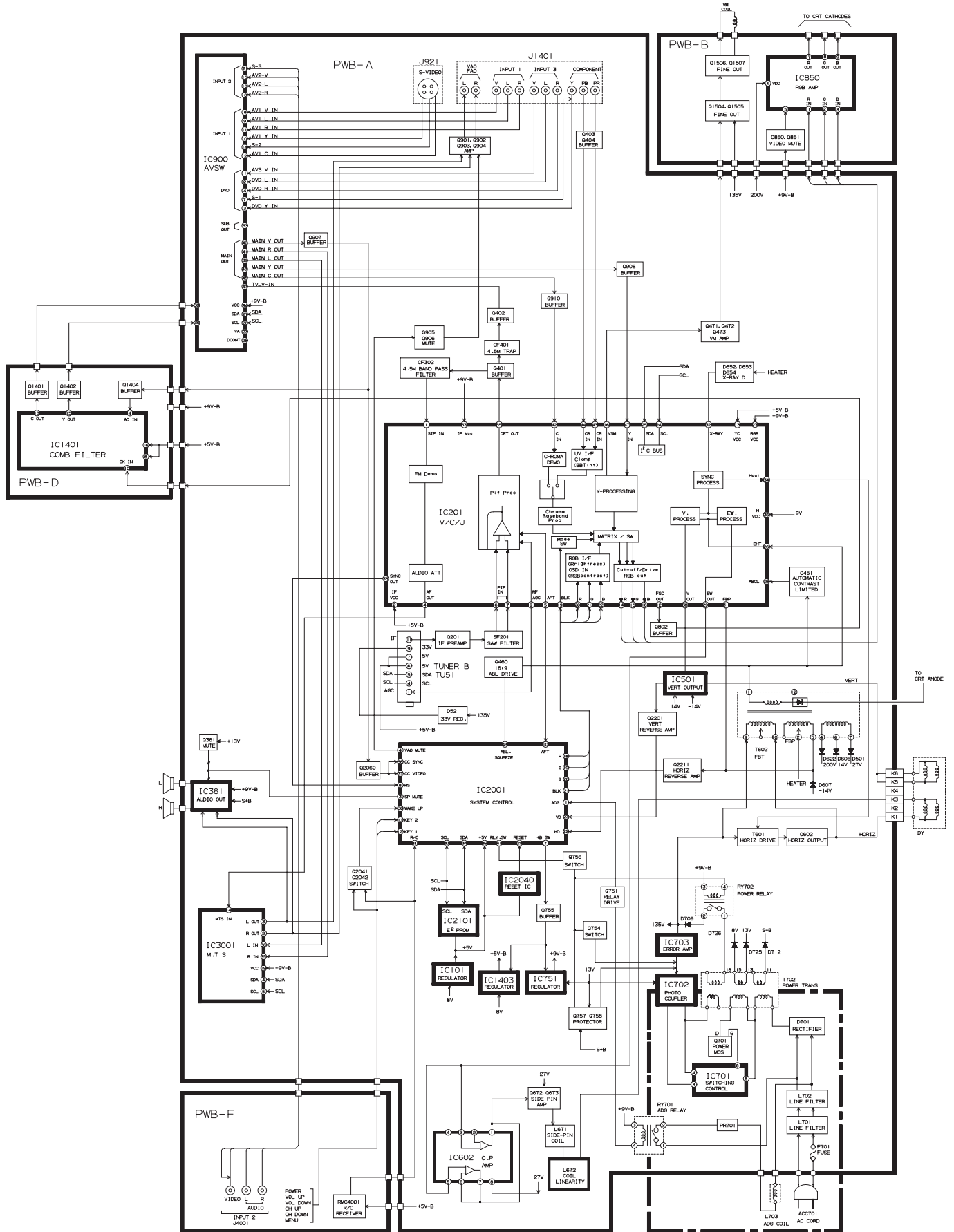

DESCRIPTION OF SCHEMATIC DIAGRAM

NOTES:

1. The unit of resistance "ohm" is omitted.
($K=k\Omega=1000\Omega$, $M=M\Omega$)
2. All resistors are 1/16 watt, unless otherwise noted.
3. All capacitors are μF , unless otherwise noted.
($P=pF=\mu\mu F$)
4. (G) indicates $\pm 2\%$ tolerance may be used.
5. \ddagger indicates line isolated ground.

VOLTAGE MEASUREMENT CONDITIONS:

1. All DC voltages are measured with DVM connected between points indicated and chassis ground, line voltage set at 120V AC and all controls set for normal picture unless otherwise indicated.
2. All voltages measured with 1000 μV B & W or Color signal.

WAVEFORM MEASUREMENT CONDITIONS:

1. Photographs taken on a standard gated color bar signal, the tint setting adjusted for proper color. The wave shapes at the red, green and blue cathodes of the picture tube depend on the tint, color level and picture control.
2. \blacktriangleright indicates waveform check points (See chart, waveforms are measured from point indicated to chassis ground.)

\triangle AND SHADED () COMPONENTS = SAFETY RELATED PARTS.
 \blacktriangle MARK= X-RAY RELATED PARTS.

This circuit diagram is a standard one, printed circuits may be subject to change for product improvement without prior notice.

WAVEFORMS

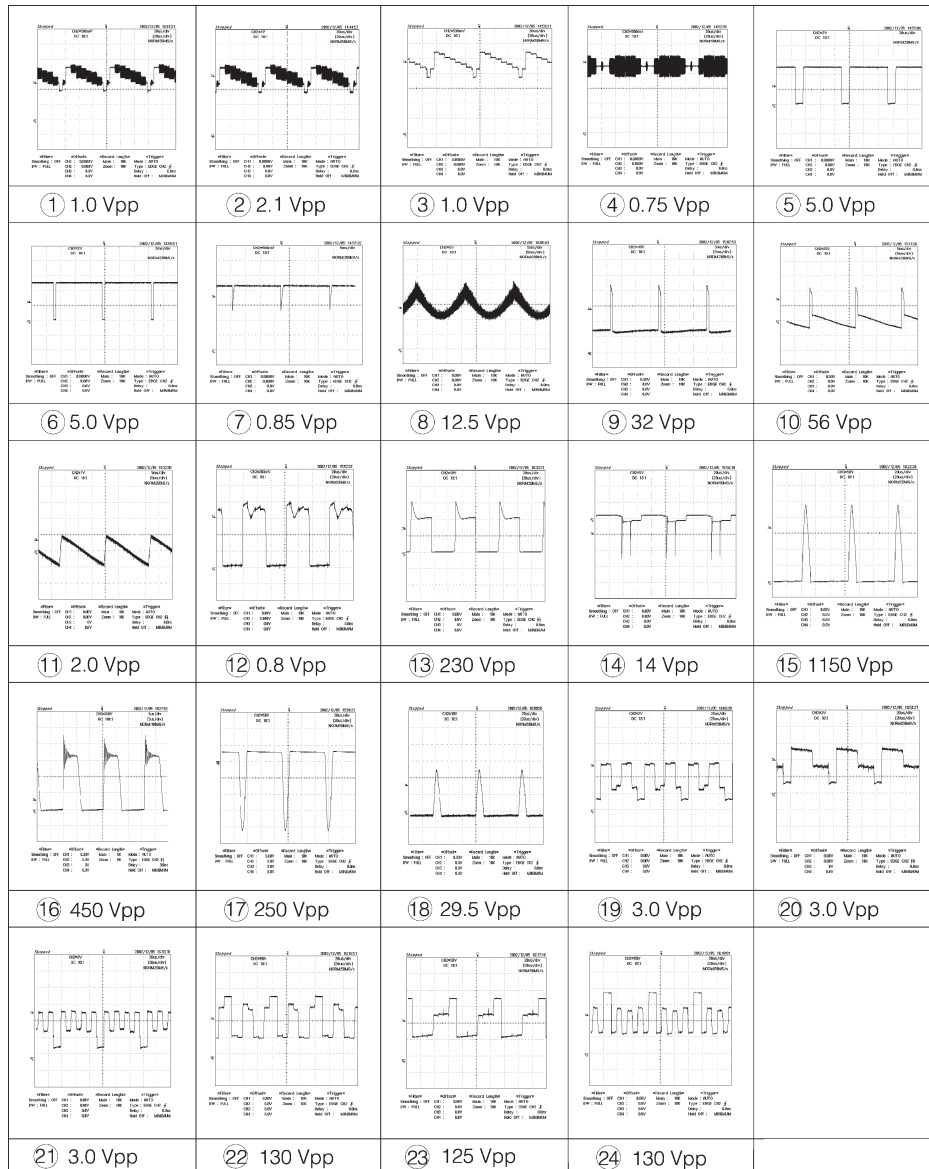

SCHEMATIC DIAGRAMS

CRT UNIT

H
G
F
E
D
C
B
A

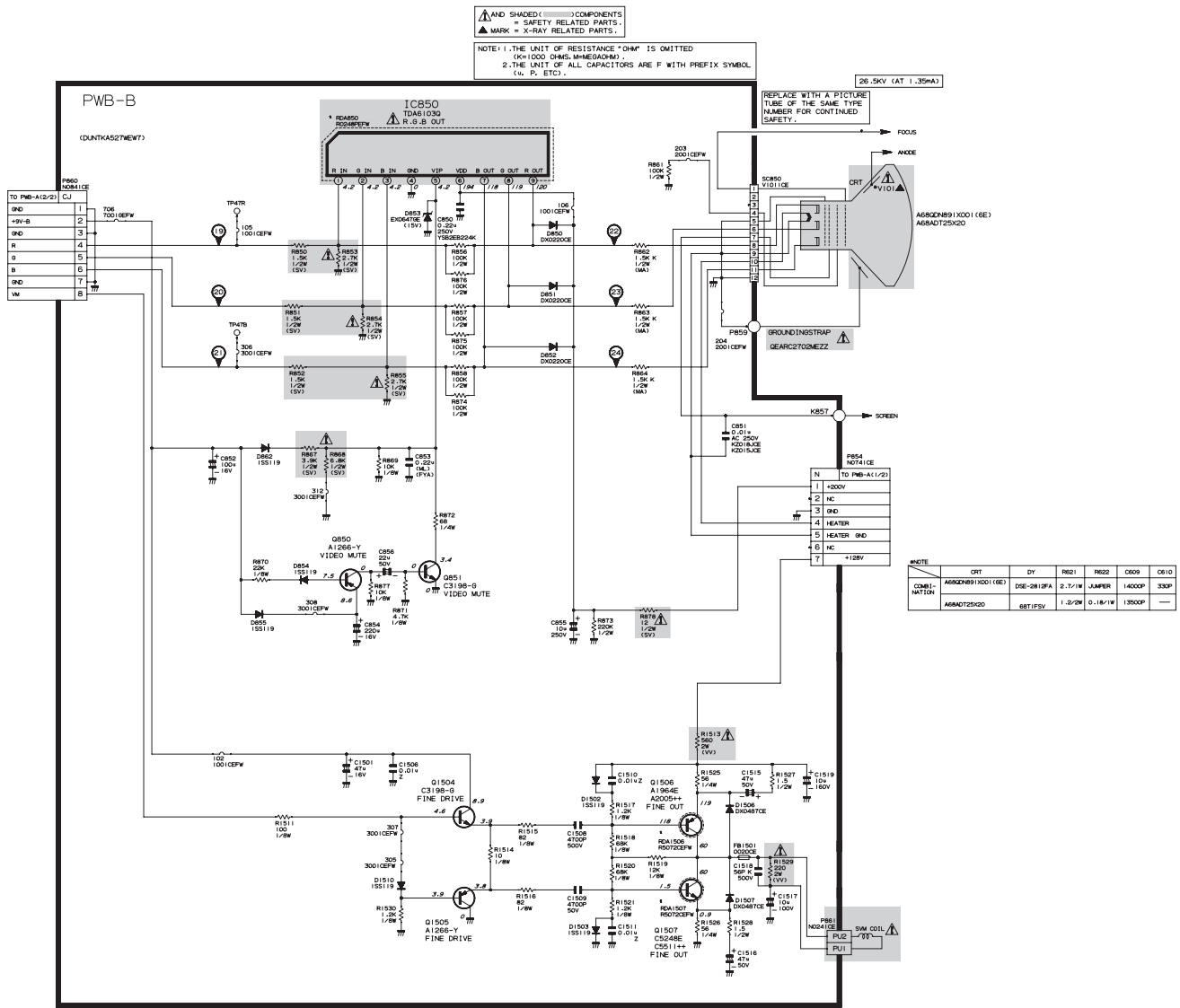

1 2 3 4 5 6

MAIN-1 UNIT

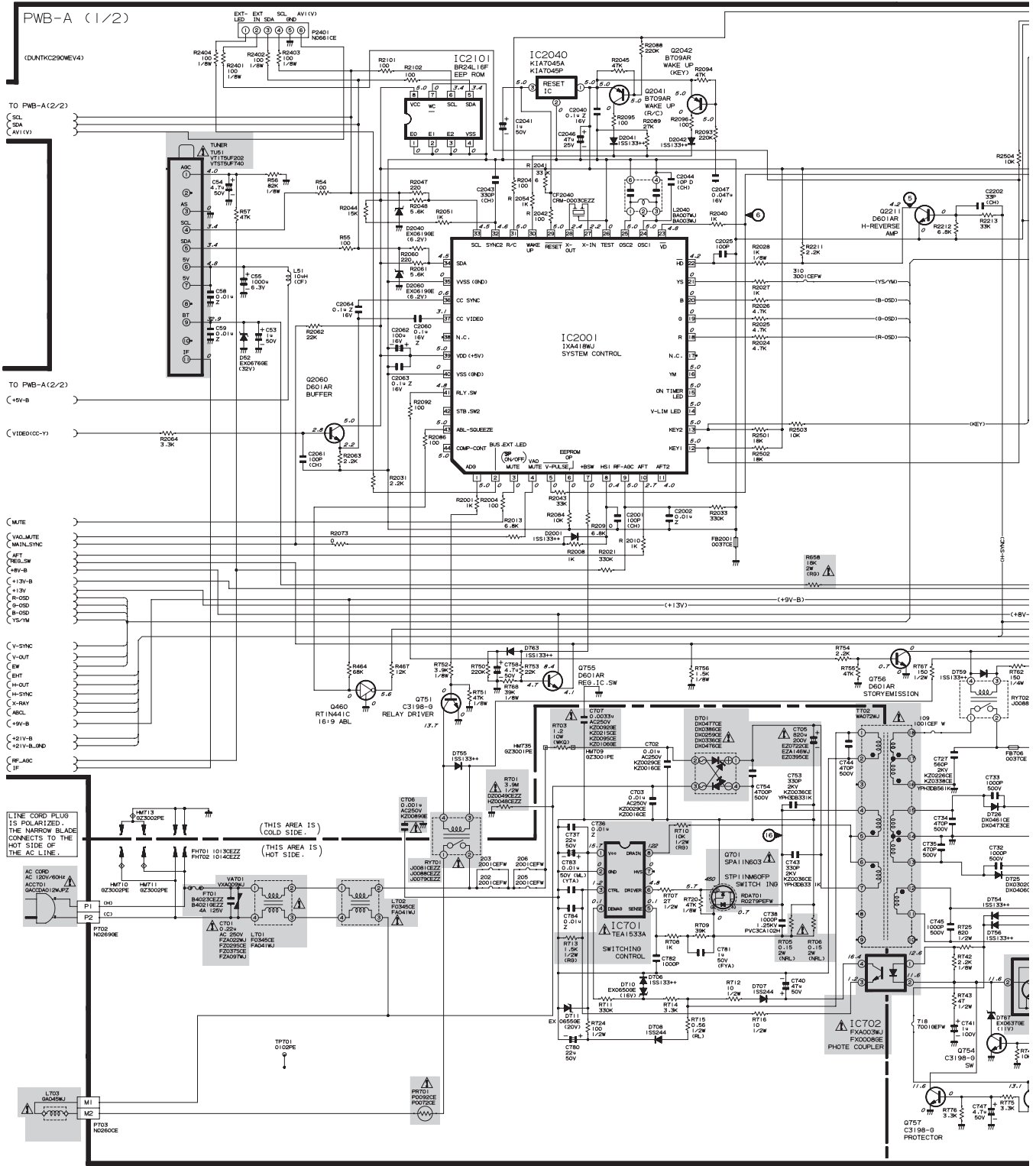

MAIN-2 UNIT

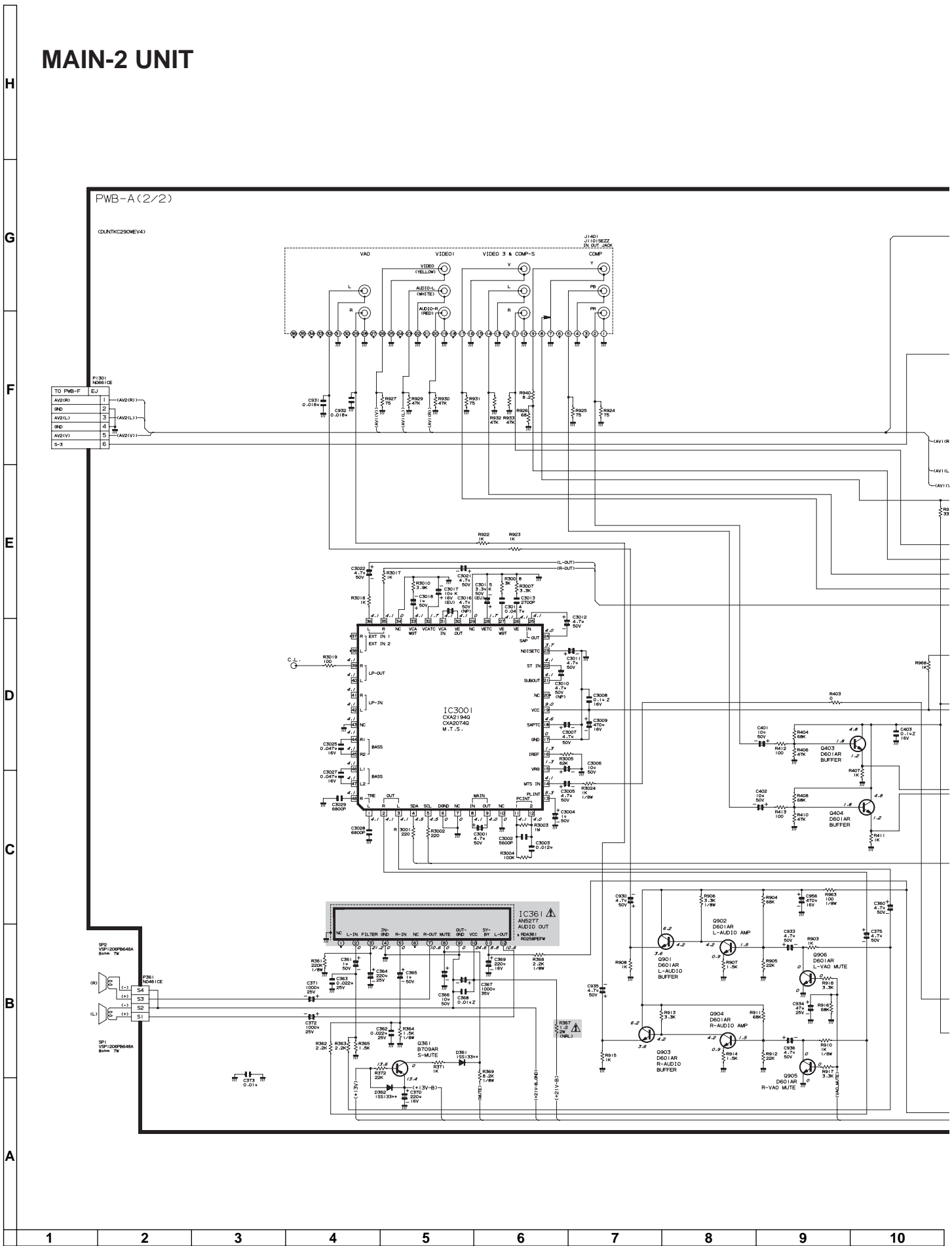

▲ AND SHADED COMPONENTS = SAFETY RELATED PARTS.
▲ MARK = X-RAY RELATED PARTS.

NOTE: 1. THE UNIT OF RESISTANCE *OMP IS OMITTED
(K=1000 OHMS, M=MEGOhm).
2. ALL RESISTORS ARE 1/8 WATT UNLESS OTHERWISE NOTED.
3. UNITY OF ALL CAPACITORS ARE P WITH PREFIX SYMBOL.
(u, p, etc.).

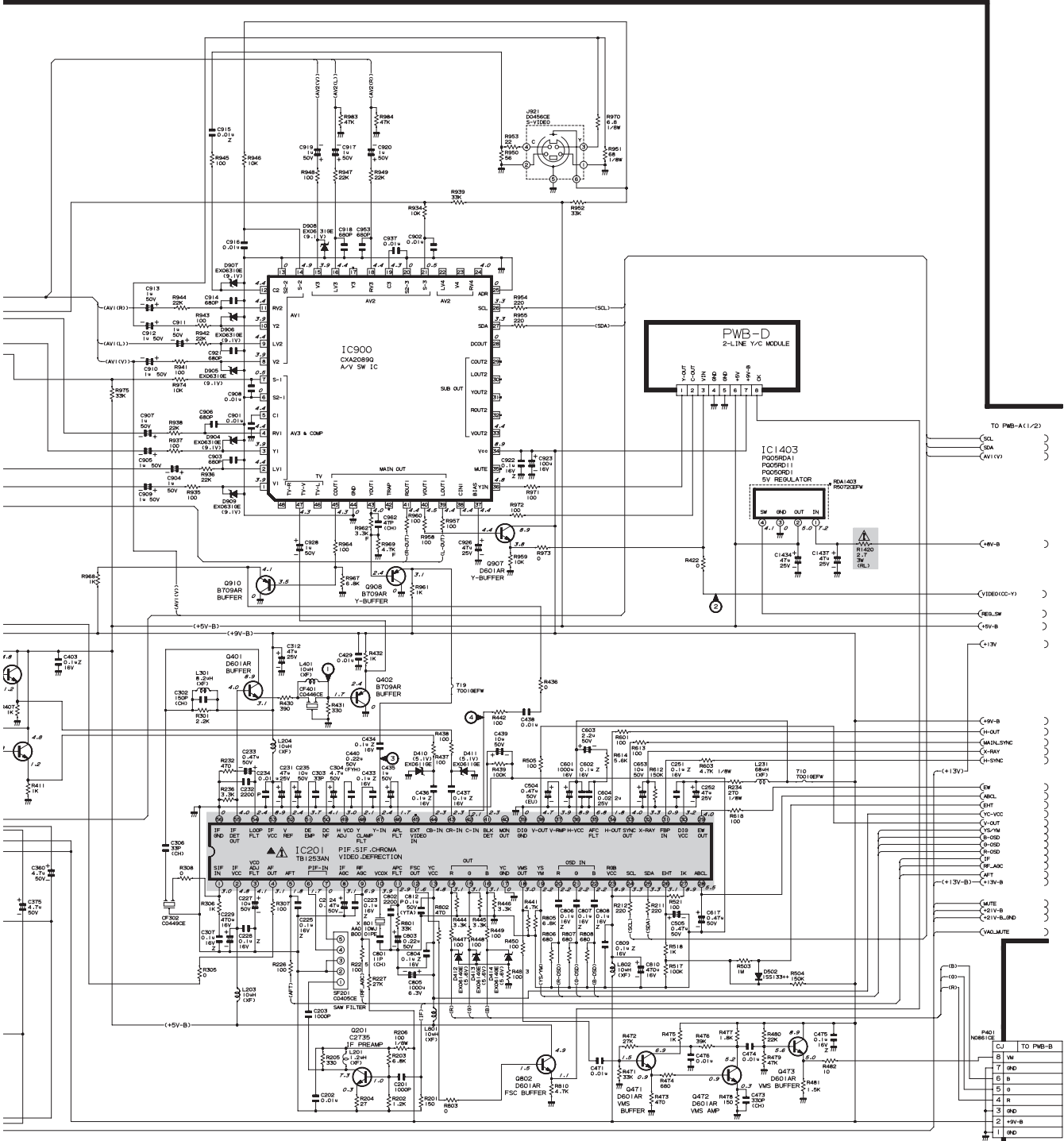

2 LINE Y/C UNIT

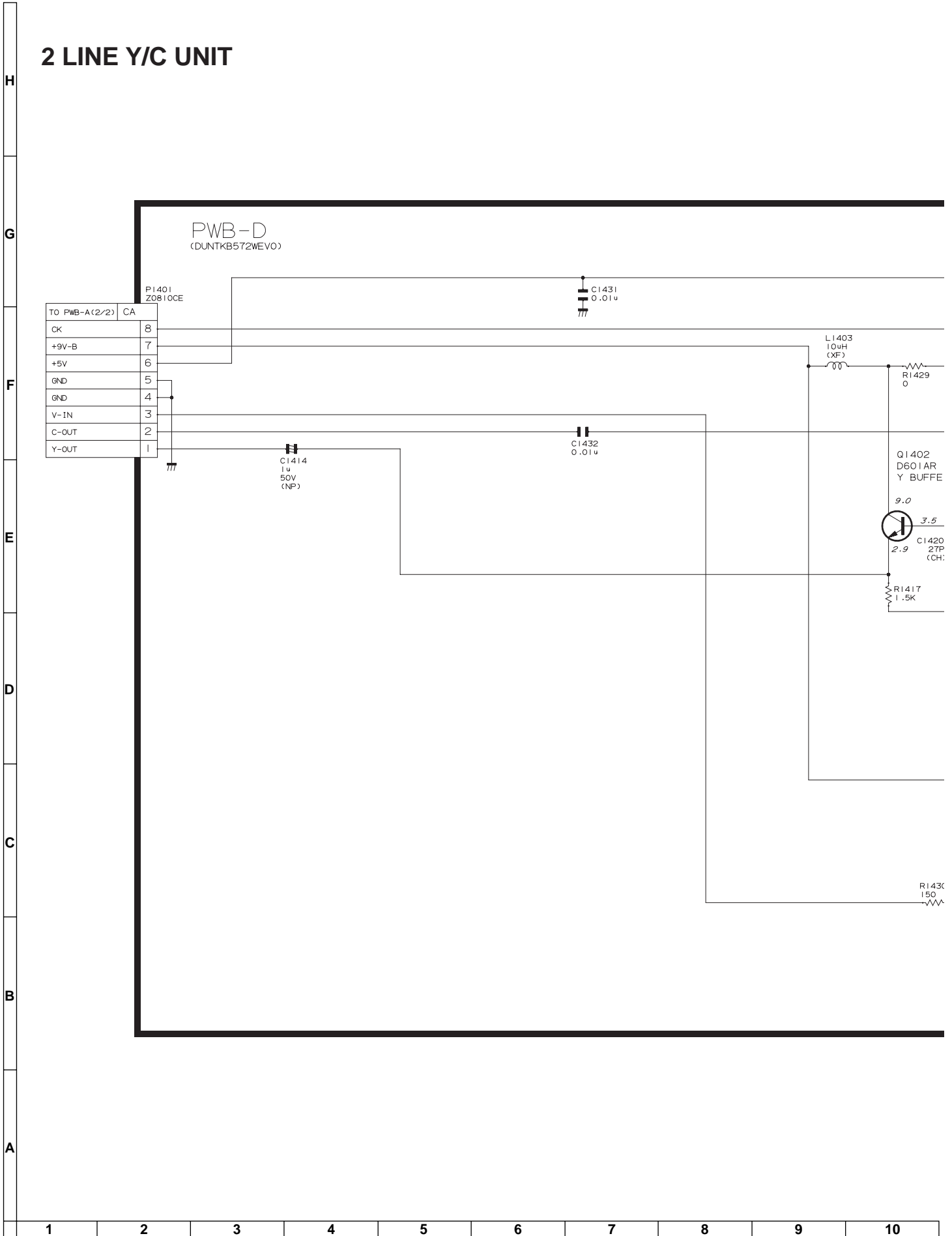

NOTE: 1. THE UNIT OF RESISTANCE "OHM" IS OMITTED
 (K=1000 OHMS, M=MEGAOHM).
 2. ALL RESISTORS ARE 1/16 WATT UNLESS OTHERWISE NOTED.
 3. UNIT OF ALL CAPACITORS ARE F WITH PREFIX SYMBOL
 (u, P, ETC).

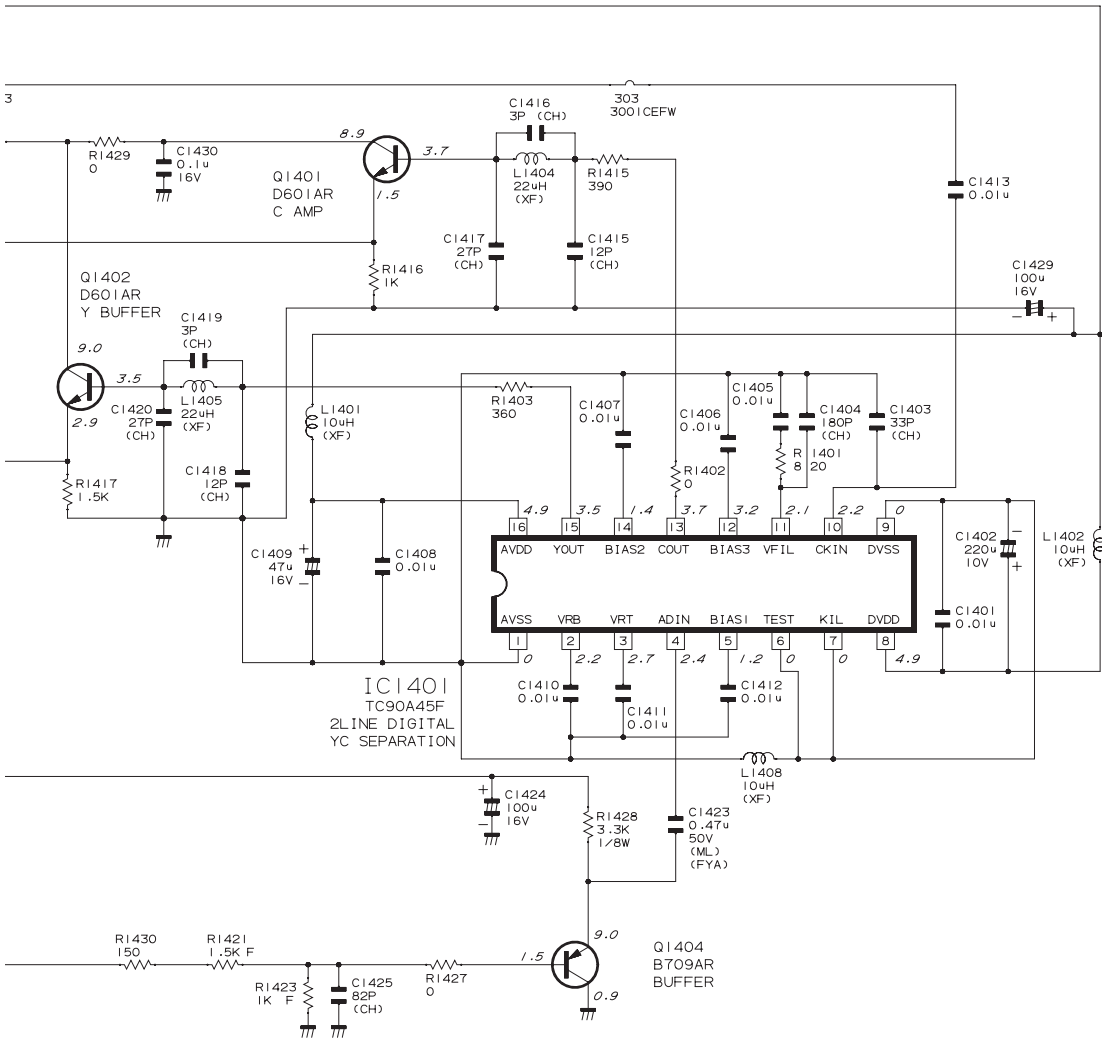

10	11	12	13	14	15	16	17	18	19
----	----	----	----	----	----	----	----	----	----

CONTROL UNIT

H
G
F
E
D
C
B
A

PWB-F

(DUNTKB207WEA5)

R/C RECEIVER
RMC4001
0222CEZZ
0235CEZZ

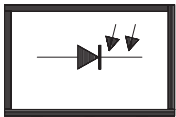

① ② ③

C4001
47u
50V

R4001
47
1/8W

S4001 KA003WJ
K0079GE K0079GE
K0202PE K0202PE
K0003AJ K0003AJ
POWER MENU

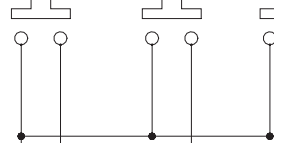

R4006
8.2K
1/8W

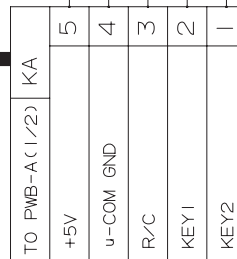

P4004
N0541CE

1 2 3 4 5 6 7 8 9 10

NOTE: 1. THE UNIT OF RESISTANCE "OHM" IS OMITTED
 (K=1000 OHMS. M=MEGAOHM).
 2. THE UNIT OF ALL CAPACITORS ARE F WITH PREFIX SYMBOL
 (u. P. ETC).

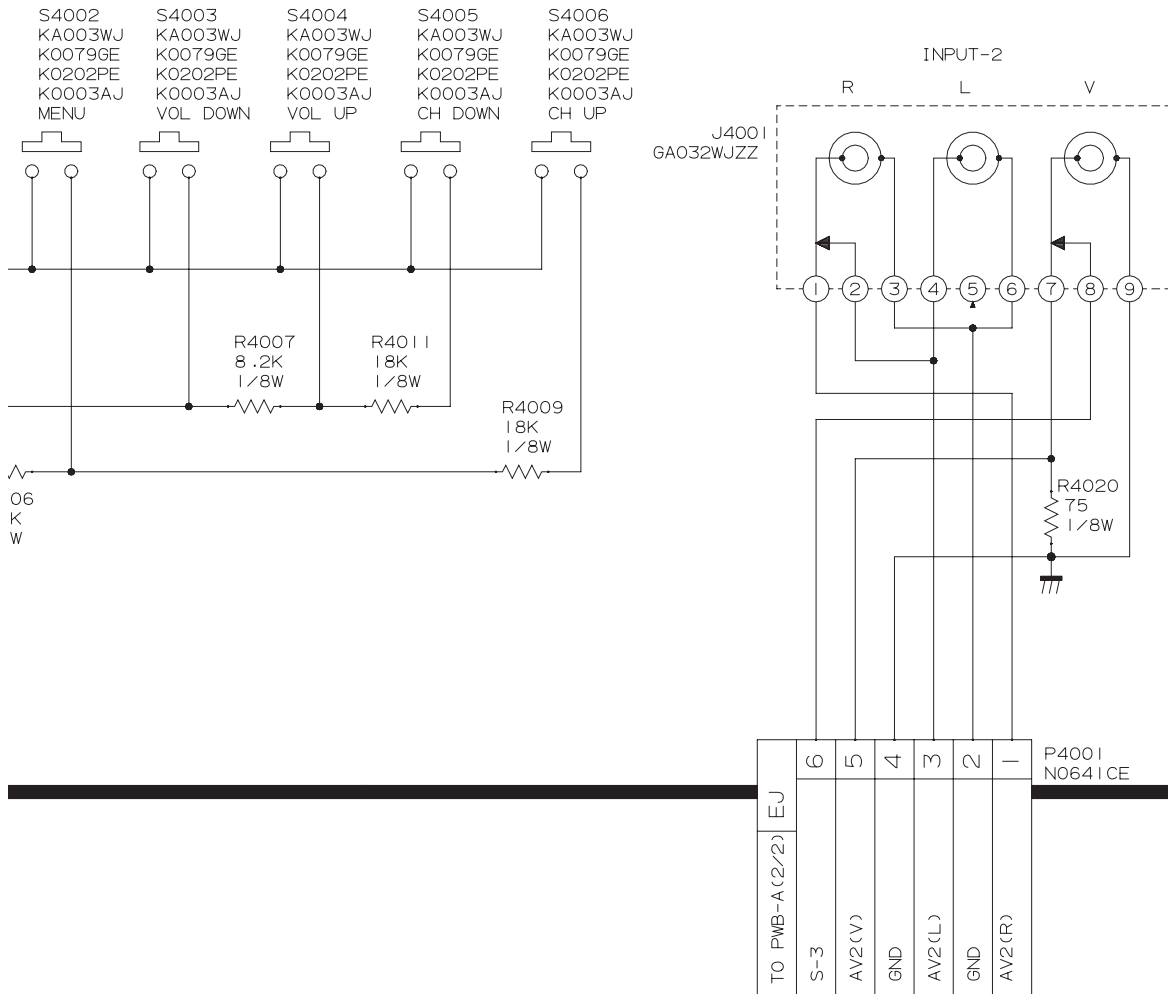

PRINTED WIRING BOARD ASSEMBLIES

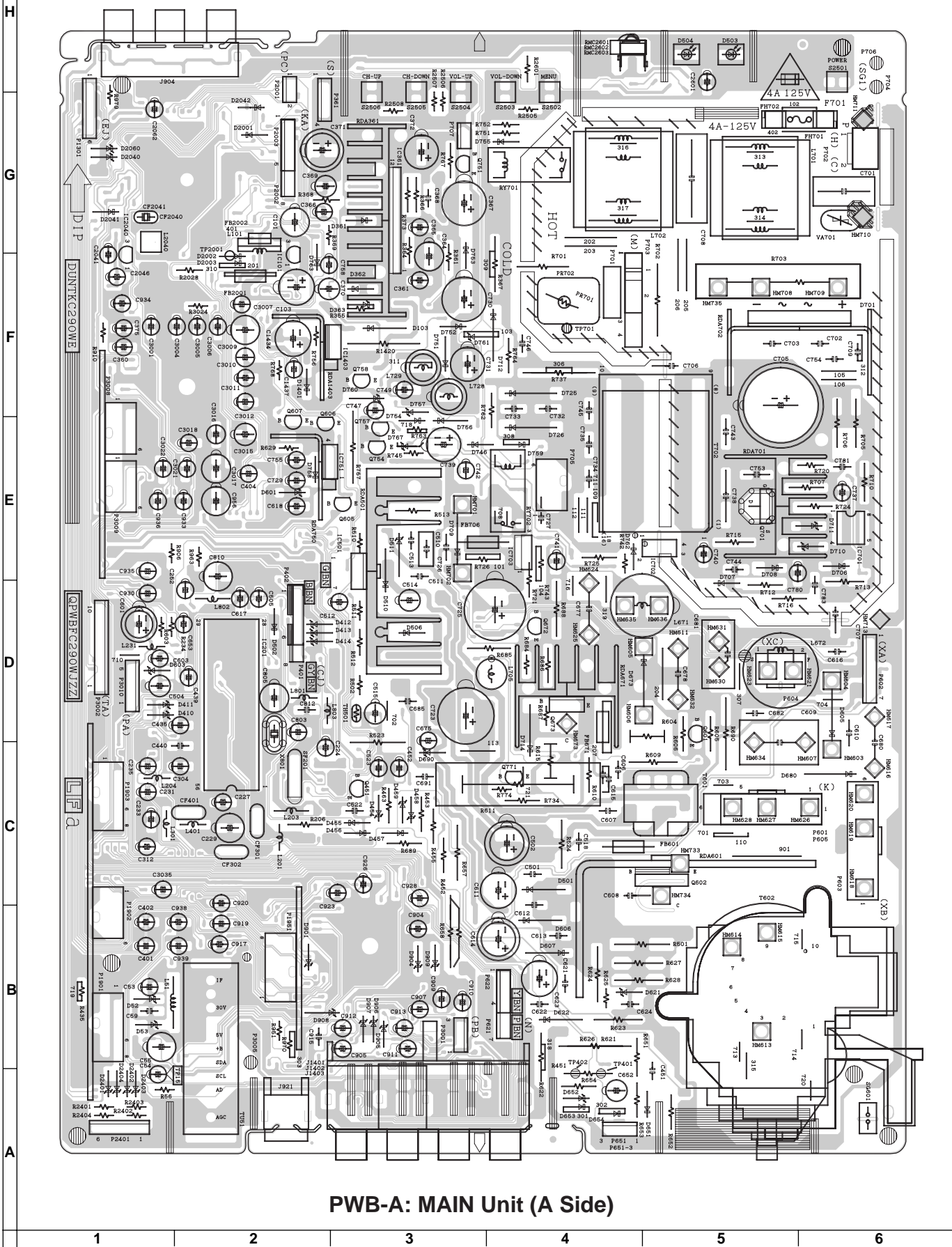

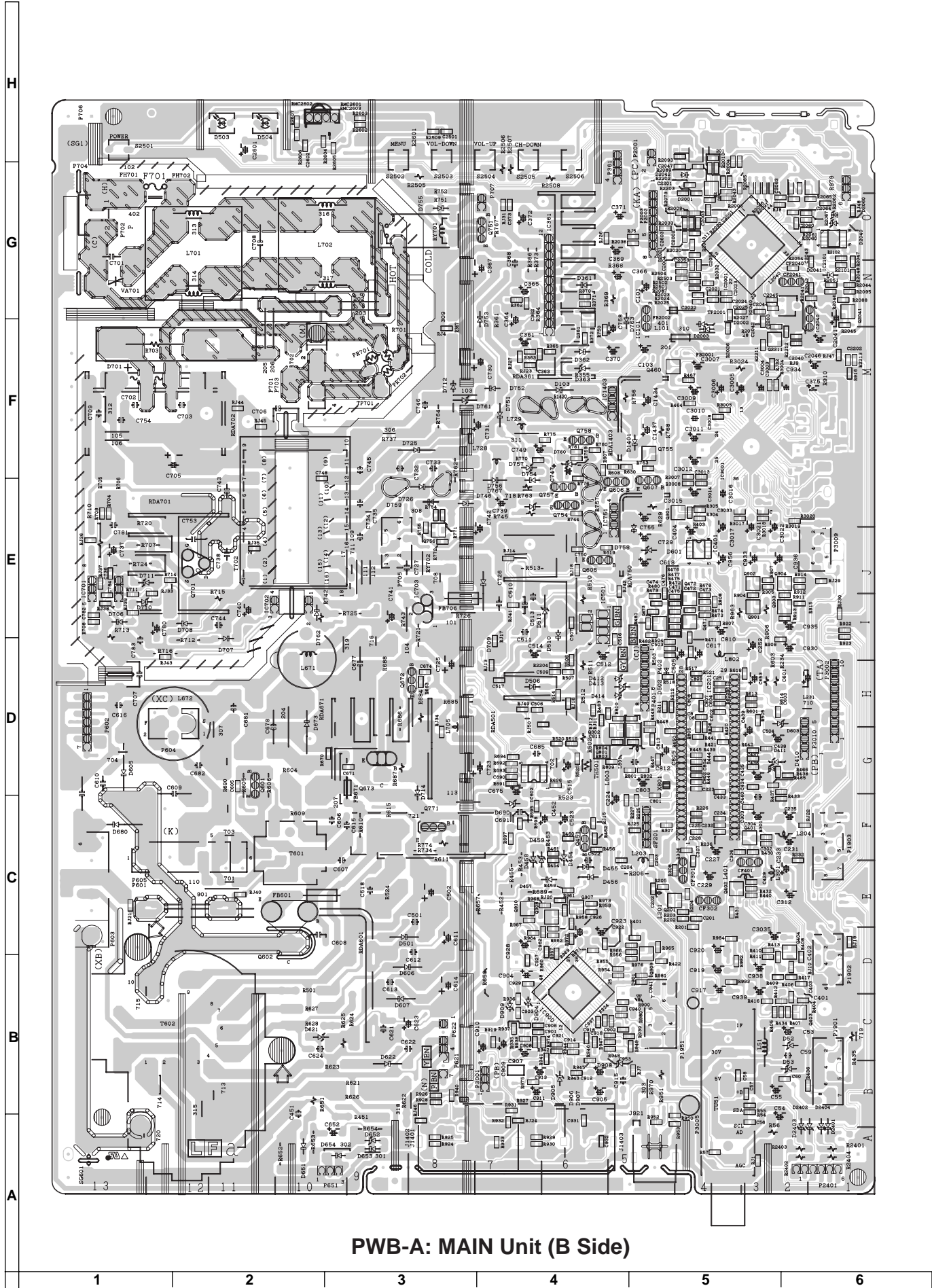

PWB-A: MAIN Unit (B Side)

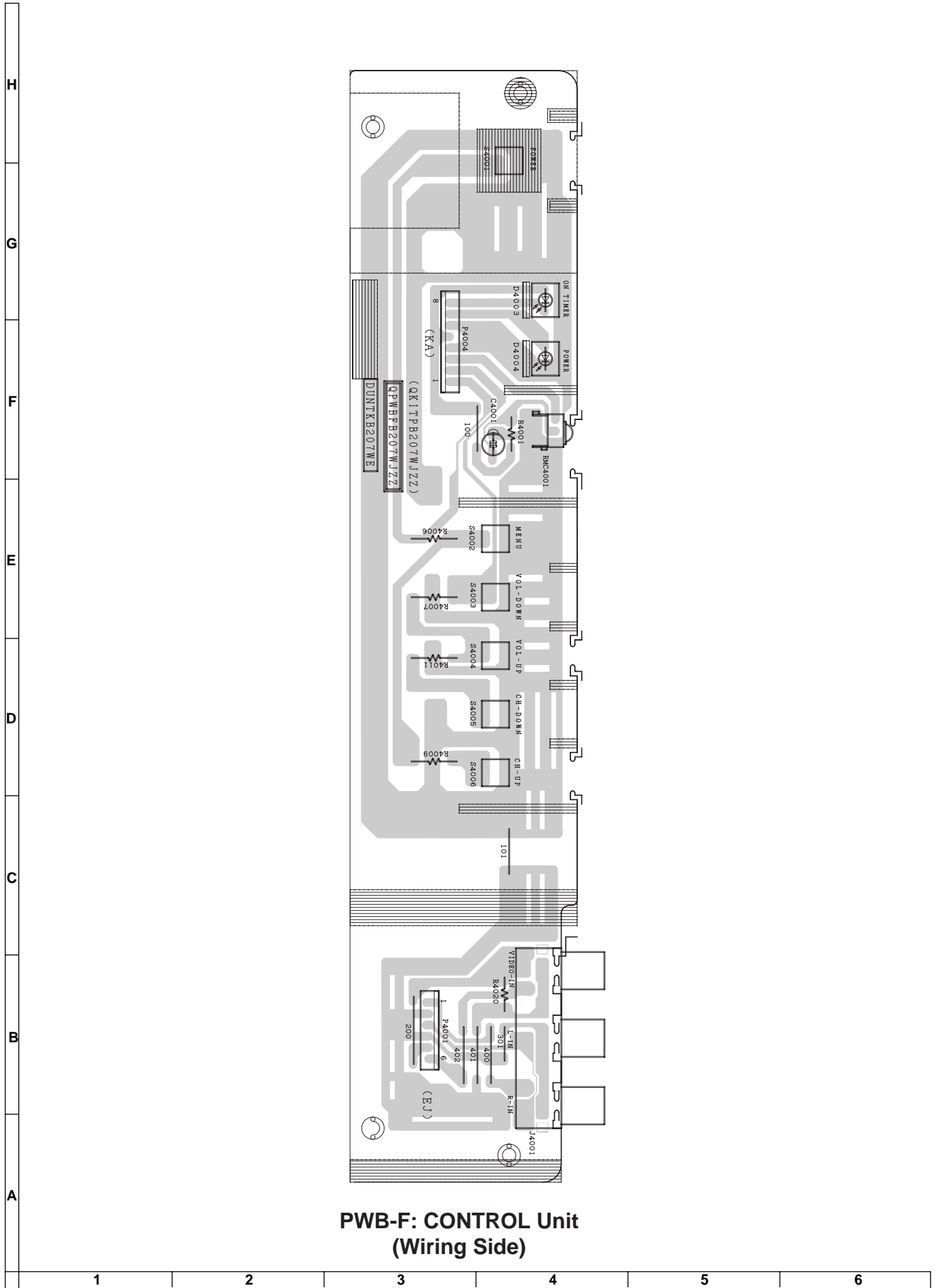

**PWB-F: CONTROL Unit
(Wiring Side)**

PARTS LIST

PARTS REPLACEMENT

Replacement parts which have these special safety characteristics identified in this manual ; electrical components having such features are identified by Δ and shaded areas in the Replacement Parts Lists and Schematic Diagrams. The use of a substitute replacement part which does not have the same safety characteristic as the factory recommended replacement parts shown in this service manual may create shock, fire or other hazards.

"HOW TO ORDER REPLACEMENT PARTS"

To have your order filled promptly and correctly, please furnish the following informations.

- | | |
|-----------------|----------------|
| 1. MODEL NUMBER | 2. REF. NO. |
| 3. PART NO. | 4. DESCRIPTION |

in **USA**: Contact your nearest SHARP Parts Distributor to order. For location of SHARP Parts Distributor, Please call Toll-Free; 1-800-BE-SHARP

★ MARK: SPARE PARTS-DELIVERY SECTION

▲ MARK: X-RAY RELATED PARTS

Ref. No.	Part No.	★	Description	Code
PICTURE TUBE				
▲ Δ V101	VB80AKS90X+1E	X	Picture Tube	CR
▲ L703	RCiLGA045WJZZ	X	Degaussing Coil	AM
Δ	QEARCA006WJZZ	X	Ground-Part	AD

PRINTED WIRING BOARD ASSEMBLIES (NOT REPLACEMENT ITEM)

PWB-A DUNTKC290WEV4	-	MAIN Unit	—
PWB-B DUNTKA527WEW7	-	CRT Unit	—
PWB-D DUNTKB572WEV0	-	2 LINE Y/C Unit	—
PWB-F DUNTKB207WEA5	-	CONTROL Unit	—

Ref. No. Part No. ★ Description Code

DUNTKC290WEV4 PWB-A MAIN UNIT

TUNER

NOTE: THE PARTS HERES SHOWN ARE SUPPLIED AS AN ASSEMBLY NOT INDEPENDENTLY

▲ TU51 VTUVT1T5UF202 X VHF Tuner AP

INTEGRATED CIRCUITS

IC101	VHiPQ050ES1-1+	X	PQ050ES1MXP	AB
▲ Δ IC201	VHiTB1253AN-1	X	TB1253AN	AP
Δ IC361	VHiAN5277/-1	X	AN5277	AG
Δ IC501	VHiTDA8177+-1	X	TDA8177	AE
IC602	VHiBA15218F2EY	X	BA15218F-E2	AB
Δ IC701	VHiTEA1533A-1	X	TEA1533AP	AE
Δ IC702	RH-FXA003WJZZ	X	PC123Y82	AB
▲ Δ IC703	VHiSE135N++-F	X	SE135N	AD
IC751	VHiPQ09RDA1-1	X	PQ090RDA1SZ	AD
IC900	VHiCXA2089Q-2Y	X	CXA2089Q-6T	AK
IC1403	VHiPQ05RDA1-1	X	PQ050RDA1SZ	AD
IC2001	RH-iXA418WJZZQ	X	TMP88CS38BFG	AN
IC2040	VHiKIA7045A-1+	X	KIA7045AP	AB
IC2101	VHiBR24L16F-1Y	X	BR24L16F-WE2	AC
IC3001	VHiCXA2194Q-1Y	X	CXA2194Q-T6	AP

TRANSISTORS

Q201	VS2SC2735//1EY	X	2SC2735	AB
Q361	VS2SB709AR/-1Y	X	2SB709AR	AB
Q401	VS2SD601AR/-1Y	X	2SD601AR	AB
Q402	VS2SB709AR/-1Y	X	2SB709AR	AB
Q403	VS2SD601AR/-1Y	X	2SD601AR	AB
Q404	VS2SD601AR/-1Y	X	2SD601AR	AB
Q451	VS2SA1266-Y-1+	X	2SA1266-Y	AB
Q460	VSRT1N441C/-1Y	X	RT1N441C	AB
Q471	VS2SD601AR/-1Y	X	2SD601AR	AB
Q472	VS2SD601AR/-1Y	X	2SD601AR	AB
Q473	VS2SD601AR/-1Y	X	2SD601AR	AB
Q601	VS2SC2482//1+	X	2SC2482	AB
▲ Q602	VS2SC5931+++F	X	2SC5931++	AG
Q672	VS2SA1266-Y-1+	X	2SA1266-Y	AB
Q673	VS2SD1830//1E	X	2SD1830	AD
▲ Q701	VSSPA11N603-1	X	SPA11N603	AK
Q751	VS2SC3198-G-1+	X	2SC3198-G	AB
Q754	VS2SC3198-G-1+	X	2SC3198-G	AB
Q755	VS2SD601AR/-1Y	X	2SD601AR	AB
Q756	VS2SD601AR/-1Y	X	2SD601AR	AB
Q757	VS2SC3198-G-1+	X	2SC3198-G	AB
Q758	VS2SA1266-Y-1+	X	2SA1266-Y	AB
Q802	VS2SD601AR/-1Y	X	2SD601AR	AB
Q901	VS2SD601AR/-1Y	X	2SD601AR	AB
Q902	VS2SD601AR/-1Y	X	2SD601AR	AB
Q903	VS2SD601AR/-1Y	X	2SD601AR	AB
Q904	VS2SD601AR/-1Y	X	2SD601AR	AB
Q905	VS2SD601AR/-1Y	X	2SD601AR	AB
Q906	VS2SD601AR/-1Y	X	2SD601AR	AB
Q907	VS2SD601AR/-1Y	X	2SD601AR	AB
Q908	VS2SB709AR/-1Y	X	2SB709AR	AB
Q910	VS2SB709AR/-1Y	X	2SB709AR	AB
Q2041	VS2SB709AR/-1Y	X	2SB709AR	AB
Q2042	VS2SB709AR/-1Y	X	2SB709AR	AB
Q2060	VS2SD601AR/-1Y	X	2SD601AR	AB
Q2201	VS2SD601AR/-1Y	X	2SD601AR	AB
Q2211	VS2SD601AR/-1Y	X	2SD601AR	AB

DIODES

D52	RH-EX0676GEZZY	X	Zener Diode, 32V	AB
D103	RH-DX0441CEZZY	X	DX0441CE	AB
D361	VHD1SS133+-1Y	X	1SS133++	AA
D362	VHD1SS133+-1Y	X	1SS133++	AA
D410	RH-EX0611GEZZY	X	Zener Diode, 5.1V	AB
D411	RH-EX0611GEZZY	X	Zener Diode, 5.1V	AB
D412	RH-EX0614GEZZY	X	Zener Diode, 5.6V	AB
D413	RH-EX0614GEZZY	X	Zener Diode, 5.6V	AB
D414	RH-EX0614GEZZY	X	Zener Diode, 5.6V	AB
D454	RH-EX0628GEZZY	X	Zener Diode, 8.2V	AB

Ref. No.	Part No.	★	Description	Code	Ref. No.	Part No.	★	Description	Code
C506	VCKYCY1HB103KY X	0.01	50V Ceramic	AA	C783	VCQYTA1HM103J+ X	0.01	50V Mylar	AB
C507	VCKYCY1HB103KY X	0.01	50V Ceramic	AA	C784	VCKYCY1HF103ZY X	0.01	50V Ceramic	AA
C510	RC-FZ0272CEZZ+ X	0.39	100V Mylar	AB	C801	VCCCCY1HH110JY X	11p	50V Ceramic	AA
C512	VCEA0A1EW476M+X	47	25V Electrolytic	AB	C802	VCKYCY1HB222KY X	2200p	50V Ceramic	AA
C514	VCEA0A1VW107M+X	100	35V Electrolytic	AB	C803	VCEA0A1HW224M+X	0.22	50V Electrolytic	AB
C516	VCKYCY1HB472KY X	4700p	50V Ceramic	AA	C804	VCKYCY1CF104ZY X	0.1	16V Ceramic	AA
C517	VCKYCY1HF103ZY X	0.01	50V Ceramic	AA	C805	VCEA0A0JW108M+ X	1000	6.3V Electrolytic	AB
C518	VCQYTA2AA473J+ X	0.047	100V Mylar	AB	C806	VCKYCY1CF104ZY X	0.1	16V Ceramic	AA
C522	VCYFA1HA334J+ X	0.33	50V Mylar	AB	C807	VCKYCY1CF104ZY X	0.1	16V Ceramic	AA
C523	VCEA0A1HW105M+X	1	50V Electrolytic	AB	C808	VCKYCY1CF104ZY X	0.1	16V Ceramic	AA
C601	VCEA0A1CW108M+X	1000	16V Electrolytic	AB	C809	VCKYCY1CF104ZY X	0.1	16V Ceramic	AA
C602	VCKYCY1CF104ZY X	0.1	16V Ceramic	AA	C810	VCEA0A1CW477M+X	470	16V Electrolytic	AB
C603	VCEA0A1HW225M+X	2.2	50V Electrolytic	AB	C812	VCQYTA1HM104J+ X	0.1	50V Mylar	AB
C604	VCKYCY1EB223KY X	0.022	25V Ceramic	AA	C901	VCKYCY1HB103KY X	0.01	50V Ceramic	AA
C606	VCKYPA2HB102K+ X	1000p	500V Ceramic	AB	C902	VCKYCY1HB103KY X	0.01	50V Ceramic	AA
C607	VCKYPA1HB472K+ X	4700p	50V Ceramic	AB	C903	VCKYCY1HB681KY X	680p	50V Ceramic	AA
C608	RC-KZ0033CEZZ X	150p	2kV Ceramic	AB	C904	VCEA0A1HW105M+X	1	50V Electrolytic	AB
▲ △ C609	VCFPVC3ZA163H X	0.016	1500V Metallized Polypro Film	AB	C905	VCEA0A1HW105M+X	1	50V Electrolytic	AB
C610	RC-KZ0038CEZZ+ X	470p	2kV	AB	C906	VCKYCY1HB681KY X	680p	50V Ceramic	AA
C611	VCEA0A1EW477M+X	470	25V Electrolytic	AB	C907	VCEA0A1HW105M+X	1	50V Electrolytic	AB
C614	VCEA0A1EW108M+X	1000	25V Electrolytic	AB	C908	VCKYCY1HB103KY X	0.01	50V Ceramic	AA
C615	VCYFSB2EB823J X	0.082	250V Mylar	AB	C909	VCEA0A1HW105M+X	1	50V Electrolytic	AB
C616	VCKYPA2HB471K+ X	470p	500V Ceramic	AB	C910	VCEA0A1HW105M+X	1	50V Electrolytic	AB
C617	VCEA0A1HW474M+X	0.47	50V Electrolytic	AB	C911	VCEA0A1HW105M+X	1	50V Electrolytic	AB
C622	VCKYPA2HB102K+ X	1000p	500V Ceramic	AB	C912	VCEA0A1HW105M+X	1	50V Electrolytic	AB
C623	VCEA4A2EN106M+ X	10	250V Electrolytic	AB	C913	VCEA0A1HW105M+X	1	50V Electrolytic	AB
C652	VCEA0A1HW476M+X	47	50V Electrolytic	AB	C914	VCKYCY1HB681KY X	680p	50V Ceramic	AA
C653	VCEA0A1HW106M+X	10	50V Electrolytic	AB	C915	VCKYPA1HF103Z+ X	0.01	50V Ceramic	AA
C674	VCKYCY1HB391KY X	390p	50V Ceramic	AA	C916	VCKYCY1HB103KY X	0.01	50V Ceramic	AA
C675	VCEA0A1HW106M+X	10	50V Electrolytic	AB	C917	VCEA0A1HW105M+X	1	50V Electrolytic	AB
C677	RC-FZ0377CEZZ X	4.7	63V Mylar	AC	C918	VCKYCY1HB681KY X	680p	50V Ceramic	AA
▲ △ C678	VCQPPC2GB563J X	0.056	400V Plastic Film	AB	C919	VCEA0A1HW105M+X	1	50V Electrolytic	AB
C681	VCFFFA2EB394J X	0.39	250V	AB	C920	VCEA0A1HW105M+X	1	50V Electrolytic	AB
C682	VCKYPA2HB102K+ X	1000p	500V Ceramic	AB	C921	VCKYCY1HB681KY X	680p	50V Ceramic	AA
C685	VCQYTA1HM333J+ X	0.033	50V Mylar	AB	C922	VCKYCY1CF104ZY X	0.1	16V Ceramic	AA
C691	VCQYTA1HM682J+ X	6800p	50V Mylar	AB	C923	VCEA0A1CW107M+X	100	16V Electrolytic	AB
△ C701	RC-FZA022WJZZ X	0.22	AC250V	AB	C926	VCEA0A1EW476M+X	47	25V Electrolytic	AB
C702	RC-KZ0029CEZZ+ X	0.01	AC250V Ceramic	AB	C928	VCEA0A1HW105M+X	1	50V Electrolytic	AB
C703	RC-KZ0029CEZZ+ X	0.01	AC250V Ceramic	AB	C930	VCEA0A1HW475M+X	4.7	50V Electrolytic	AB
△ C705	RC-EZ0722CEZZ X	820	200V Electrolytic	AG	C931	VCKYCY1HB183KY X	0.018	50V Ceramic	AA
△ C706	RC-KZ0089GEZZA X	0.001	AC250V Ceramic	AB	C932	VCKYCY1HB183KY X	0.018	50V Ceramic	AA
△ C707	RC-KZ0092GEZZA X	0.0033	AC250V Ceramic	AB	C933	VCEA0A1HW475M+X	4.7	50V Electrolytic	AB
△ C723	RC-EZ0724CEZZ X	100	160V Electrolytic	AC	C934	VCEA0A1EW476M+X	47	25V Electrolytic	AB
△ C725	RC-EZA065WJZZ X	330	160V Electrolytic	AE	C935	VCEA0A1HW475M+X	4.7	50V Electrolytic	AB
C726	RC-KZ0226CEZZ+ X	560p	2kV Ceramic	AB	C936	VCEA0A1HW475M+X	4.7	50V Electrolytic	AB
C727	RC-KZ0226CEZZ+ X	560p	2kV Ceramic	AB	C937	VCKYCY1HB103KY X	0.01	50V Ceramic	AA
C729	VCEA0A1HW106M+X	10	50V Electrolytic	AB	C953	VCKYCY1HB681KY X	680p	50V Ceramic	AA
C730	VCEA4A1VN108M+ X	1000	35V Electrolytic	AC	C956	VCEA0A1CW477M+X	470	16V Electrolytic	AB
C731	RC-EZ0385CEZZ+ X	1000	16V Electrolytic	AB	C962	VCCCCY1HH470JY X	47p	50V Ceramic	AA
C732	VCKYPA2HB102K+ X	1000p	500V Ceramic	AB	C1434	VCEA0A1EW476M+X	47	25V Electrolytic	AB
C733	VCKYPA2HB102K+ X	1000p	500V Ceramic	AB	C1437	VCEA0A1EW476M+X	47	25V Electrolytic	AB
C734	VCKYPA2HB471K+ X	470p	500V Ceramic	AB	C2001	VCCCCY1HH101JY X	100p	50V Ceramic	AA
C735	VCKYPA2HB471K+ X	470p	500V Ceramic	AB	C2002	VCKYCY1HF103ZY X	0.01	50V Ceramic	AA
C736	VCKYCY1HF103ZY X	0.01	50V Ceramic	AA	C2025	VCCCCY1HH101JY X	100p	50V Ceramic	AA
C737	VCEA0A1HW226M+X	22	50V Electrolytic	AB	C2040	VCKYCY1CF104ZY X	0.1	16V Ceramic	AA
C738	VCFPVC3CA102H X	1000p	1.25kV Metallized Polypro Film	AB	C2041	VCEA0A1HW105M+X	1	50V Electrolytic	AB
C739	RC-EZ0385CEZZ+ X	1000	16V Electrolytic	AB	C2043	VCCCCY1HH331JY X	330p	50V Ceramic	AB
C740	VCEA0A1HW476M+X	47	50V Electrolytic	AB	C2044	VCCCCY1HH100DYX	10p	50V Ceramic	AA
C741	VCEA4A2AN105M+ X	1	100V Electrolytic	AB	C2046	VCEA0A1EW476M+X	47	25V Electrolytic	AB
C742	VCEA0A1HW226M+X	22	50V Electrolytic	AB	C2047	VCKYCY1CB473KY X	0.047	16V Ceramic	AA
C743	RC-KZ0036CEZZ+ X	330p	2kV Ceramic	AB	C2060	VCKYCY1CF104ZY X	0.1	16V Ceramic	AA
C744	VCKYPA2HB471K+ X	470p	500V Ceramic	AB	C2061	VCCCCY1HH101JY X	100p	50V Ceramic	AA
C745	VCKYPA2HB102K+ X	1000p	500V Ceramic	AB	C2062	VCEA0A1CW107M+X	100	16V Electrolytic	AB
C746	VCKYPA2HB102K+ X	1000p	500V Ceramic	AB	C2063	VCKYCY1CF104ZY X	0.1	16V Ceramic	AA
C747	VCEA0A1HW475M+X	4.7	50V Electrolytic	AB	C2064	VCKYCY1CF104ZY X	0.1	16V Ceramic	AA
C750	VCKYCY1HF103ZY X	0.01	50V Ceramic	AA	C2201	VCKYCY1HB681KY X	680p	50V Ceramic	AA
C753	RC-KZ0036CEZZ+ X	330p	2kV Ceramic	AB	C2202	VCCCCY1HH330JY X	33p	50V Ceramic	AA
C754	VCKYPA2HB472K+ X	4700p	500V Ceramic	AB	C2501	VCKYCY1HB102KY X	1000p	50V Ceramic	AA
C755	VCEA0A1EW476M+X	47	25V Electrolytic	AB	C2603	VCCCCY1HH101JY X	100p	50V Ceramic	AA
C758	VCEA0A1HW475M+X	4.7	50V Electrolytic	AB	C3001	VCEA0A1HW475M+X	4.7	50V Electrolytic	AB
C780	VCEA0A1HW226M+X	22	50V Electrolytic	AB	C3002	VCKYCY1HB562KY X	5600p	50V Ceramic	AA
C781	VCYFA1HA105J+ X	1	50V	AB	C3003	VCKYCY1EB123KY X	0.012	25V Ceramic	AA
C782	VCKYCY1HB102KY X	1000p	50V Ceramic	AA	C3004	VCEA0A1HW105M+X	1	50V Electrolytic	AB
					C3005	VCEA0A1HW475M+X	4.7	50V Electrolytic	AB
					C3006	VCEA0A1HW106M+X	10	50V Electrolytic	AB
					C3007	VCEA0A1HW475M+X	4.7	50V Electrolytic	AB

Ref. No.	Part No.	★	Description	Code	Ref. No.	Part No.	★	Description	Code
C3008	VCKYCY1CF104ZY	X 0.1	16V Ceramic	AA	R365	VRS-CY1JF152JY	X 1.5k	1/16W Metal Oxide	AA
C3009	VCEAOA1CW477M+X	470	16V Electrolytic	AB	△ R367	VRN-RL3DB1R2J+	X 1.2	2W Metal Film	AB
C3010	VCE9GA1HW475M+X	4.7	50V Electrolytic	AB	R368	VRD-RA2BE222JY	X 2.2k	1/8W Carbon	AA
C3011	VCEAOA1HW475M+X	4.7	50V Electrolytic	AB	R369	VRD-RA2BE822JY	X 8.2k	1/8W Carbon	AA
C3012	VCEAOA1HW475M+X	4.7	50V Electrolytic	AB	R371	VRS-CY1JF102JY	X 1k	1/16W Metal Oxide	AA
C3013	VCKYCY1HB272KY	X 2700p	50V Ceramic	AA	R372	VRS-CY1JF223JY	X 22k	1/16W Metal Oxide	AA
C3014	VCKYCY1CB473KY	X 0.047	16V Ceramic	AA	R403	VRS-CY1JF000JY	X 0	1/16W Metal Oxide	AA
C3015	VCEACA1HC335K+X	3.3	50V Electrolytic	AB	R404	VRS-CY1JF683JY	X 68k	1/16W Metal Oxide	AA
C3016	VCE9GA1HW475M+X	4.7	50V Electrolytic	AB	R406	VRS-CY1JF473JY	X 47k	1/16W Metal Oxide	AA
C3017	VCEACA1CC106K+X	10	16V Electrolytic	AB	R407	VRS-CY1JF102JY	X 1k	1/16W Metal Oxide	AA
C3018	VCEAOA1HW105M+X	1	50V Electrolytic	AB	R408	VRS-CY1JF683JY	X 68k	1/16W Metal Oxide	AA
C3021	VCEAOA1HW475M+X	4.7	50V Electrolytic	AB	R410	VRS-CY1JF473JY	X 47k	1/16W Metal Oxide	AA
C3022	VCEAOA1HW475M+X	4.7	50V Electrolytic	AB	R411	VRS-CY1JF102JY	X 1k	1/16W Metal Oxide	AA
C3025	VCKYCY1CB473KY	X 0.047	16V Ceramic	AA	R412	VRS-CY1JF101JY	X 100	1/16W Metal Oxide	AA
C3027	VCKYCY1CB473KY	X 0.047	16V Ceramic	AA	R413	VRS-CY1JF101JY	X 100	1/16W Metal Oxide	AA
C3028	VCKYCY1HB682KY	X 6800p	50V Ceramic	AA	R422	VRS-CY1JF000JY	X 0	1/16W Metal Oxide	AA
C3029	VCKYCY1HB682KY	X 6800p	50V Ceramic	AA	R430	VRS-CY1JF391JY	X 390	1/16W Metal Oxide	AA
					R431	VRS-CY1JF331JY	X 330	1/16W Metal Oxide	AA
					R432	VRS-CY1JF102JY	X 1k	1/16W Metal Oxide	AA
					R436	VRS-CY1JF000JY	X 0	1/16W Metal Oxide	AA
					R437	VRS-CY1JF101JY	X 100	1/16W Metal Oxide	AA
					R438	VRS-CY1JF101JY	X 100	1/16W Metal Oxide	AA
					R439	VRS-CY1JF104JY	X 100k	1/16W Metal Oxide	AA
					R441	VRS-CY1JF472JY	X 47k	1/16W Metal Oxide	AA
					R442	VRS-CY1JF101JY	X 100	1/16W Metal Oxide	AA
					R444	VRS-CY1JF332JY	X 3.3k	1/16W Metal Oxide	AA
					R445	VRS-CY1JF332JY	X 3.3k	1/16W Metal Oxide	AA
					R446	VRS-CY1JF332JY	X 3.3k	1/16W Metal Oxide	AA
					R447	VRS-CY1JF101JY	X 100	1/16W Metal Oxide	AA
					R448	VRS-CY1JF101JY	X 100	1/16W Metal Oxide	AA
					R449	VRS-CY1JF101JY	X 100	1/16W Metal Oxide	AA
					R450	VRS-CY1JF101JY	X 100	1/16W Metal Oxide	AA
					△ R451	VRS-RG3AB103J+	X 10k	1W Metal Oxide	AB
					R452	VRD-RM2HD473JY	X 47k	1/2W Carbon	AA
					R453	VRD-RM2HD223JY	X 22k	1/2W Carbon	AA
					R454	VRS-CY1JF471JY	X 47k	1/16W Metal Oxide	AA
					R456	VRS-CY1JF103JY	X 10k	1/16W Metal Oxide	AA
					R460	VRS-CY1JF471JY	X 47k	1/16W Metal Oxide	AA
					R461	VRS-CY1JF562JY	X 5.6k	1/16W Metal Oxide	AA
					R462	VRS-CY1JF223JY	X 22k	1/16W Metal Oxide	AA
					R463	VRD-RA2EE680JY	X 68	1/4W Carbon	AA
					R464	VRS-CY1JF683JY	X 68k	1/16W Metal Oxide	AA
					R467	VRS-CY1JF123JY	X 12k	1/16W Metal Oxide	AA
					R471	VRS-CY1JF333JY	X 33k	1/16W Metal Oxide	AA
					R472	VRS-CY1JF273JY	X 27k	1/16W Metal Oxide	AA
					R473	VRS-CY1JF471JY	X 47k	1/16W Metal Oxide	AA
					R474	VRS-CY1JF681JY	X 68k	1/16W Metal Oxide	AA
					R475	VRS-CY1JF102JY	X 1k	1/16W Metal Oxide	AA
					R476	VRS-CY1JF393JY	X 39k	1/16W Metal Oxide	AA
					R477	VRS-CY1JF182JY	X 1.8k	1/16W Metal Oxide	AA
					R478	VRS-CY1JF151JY	X 15k	1/16W Metal Oxide	AA
					R479	VRS-CY1JF473JY	X 47k	1/16W Metal Oxide	AA
					R480	VRS-CY1JF223JY	X 22k	1/16W Metal Oxide	AA
					R481	VRS-CY1JF152JY	X 1.5k	1/16W Metal Oxide	AA
					R482	VRS-CY1JF100JY	X 10	1/16W Metal Oxide	AA
					R483	VRS-CY1JF101JY	X 100	1/16W Metal Oxide	AA
					△ R501	VRN-RL3ABR47J+	X 0.47	1W Metal Film	AB
					R502	VRN-RA2BK822FY	X 8.2k	1/8W Metal Film	AB
					R503	VRS-CY1JF105JY	X 1M	1/16W Metal Oxide	AA
					R504	VRS-CY1JF154JY	X 150k	1/16W Metal Oxide	AA
					R505	VRS-CY1JF101JY	X 100	1/16W Metal Oxide	AA
					R510	VRN-RA2BK103FY	X 10k	1/8W Metal Film	AB
					R511	VRN-RA2BK222FY	X 2.2k	1/8W Metal Film	AB
					R512	VRN-RA2BK272FY	X 2.7k	1/8W Metal Film	AB
					R513	VRD-RM2HD1R5JY	X 1.5	1/2W Carbon	AA
					R517	VRS-CY1JF104JY	X 100k	1/16W Metal Oxide	AA
					R518	VRS-CY1JF102JY	X 1k	1/16W Metal Oxide	AA
					R521	VRS-CY1JF101JY	X 100	1/16W Metal Oxide	AA
					△ R523	VRN-RL3DBR82J+	X 0.82	2W Metal Film	AB
					△ R524	VRS-RG3AB561J+	X 560	1W Metal Oxide	AB
					R601	VRS-CY1JF101JY	X 100	1/16W Metal Oxide	AA
					R603	VRD-RA2BE472JY	X 4.7k	1/8W Carbon	AA
					△ R604	VRS-KA3NG562J	X 5.6k	7W Metal Oxide	AB
					R605	VRD-RM2HD331JY	X 330	1/2W Carbon	AA
					R606	VRD-RM2HD331JY	X 330	1/2W Carbon	AA
					△ R609	VRS-RG3DB332J+	X 3.3k	2W Metal Oxide	AB
RESISTORS									
RJ1	VRS-CY1JF000JY	X 0	1/16W Metal Oxide	AA					
RJ7	VRS-CY1JF000JY	X 0	1/16W Metal Oxide	AA					
RJ8	VRS-CY1JF000JY	X 0	1/16W Metal Oxide	AA					
RJ9	VRS-CY1JF000JY	X 0	1/16W Metal Oxide	AA					
RJ10	VRS-CY1JF000JY	X 0	1/16W Metal Oxide	AA					
RJ11	VRS-CY1JF000JY	X 0	1/16W Metal Oxide	AA					
RJ12	VRS-CY1JF000JY	X 0	1/16W Metal Oxide	AA					
RJ13	VRS-CY1JF000JY	X 0	1/16W Metal Oxide	AA					
RJ14	VRS-CY1JF000JY	X 0	1/16W Metal Oxide	AA					
RJ15	VRS-CY1JF000JY	X 0	1/16W Metal Oxide	AA					
RJ16	VRS-CY1JF000JY	X 0	1/16W Metal Oxide	AA					
RJ19	VRS-CY1JF000JY	X 0	1/16W Metal Oxide	AA					
RJ20	VRS-CY1JF000JY	X 0	1/16W Metal Oxide	AA					
RJ21	VRS-CY1JF000JY	X 0	1/16W Metal Oxide	AA					
RJ22	VRS-CY1JF000JY	X 0	1/16W Metal Oxide	AA					
RJ23	VRS-CY1JF000JY	X 0	1/16W Metal Oxide	AA					
RJ24	VRS-CY1JF000JY	X 0	1/16W Metal Oxide	AA					
RJ25	VRS-CY1JF000JY	X 0	1/16W Metal Oxide	AA					
RJ30	VRS-CY1JF000JY	X 0	1/16W Metal Oxide	AA					
RJ33	VRS-CY1JF000JY	X 0	1/16W Metal Oxide	AA					
RJ36	VRS-CY1JF000JY	X 0	1/16W Metal Oxide	AA					
RJ38	VRS-CY1JF000JY	X 0	1/16W Metal Oxide	AA					
RJ39	VRS-CY1JF000JY	X 0	1/16W Metal Oxide	AA					
RJ40	VRS-CY1JF000JY	X 0	1/16W Metal Oxide	AA					
RJ42	VRS-CY1JF000JY	X 0	1/16W Metal Oxide	AA					
RJ45	VRS-CY1JF000JY	X 0	1/16W Metal Oxide	AA					
RJ47	VRS-CY1JF000JY	X 0	1/16W Metal Oxide	AA					
RJ48	VRS-CY1JF000JY	X 0	1/16W Metal Oxide	AA					
RJ50	VRS-CY1JF000JY	X 0	1/16W Metal Oxide	AA					
R54	VRS-CY1JF101JY	X 100	1/16W Metal Oxide	AA					
R55	VRS-CY1JF101JY	X 100	1/16W Metal Oxide	AA					
R56	VRD-RA2BE823JY	X 82k	1/8W Carbon	AA					
R57	VRS-CY1JF473JY	X 47k	1/16W Metal Oxide	AA					
R201	VRS-CY1JF151JY	X 15k	1/16W Metal Oxide	AA					
R202	VRS-CY1JF122JY	X 1.2k	1/16W Metal Oxide	AA					
R203	VRS-CY1JF682JY	X 6.8k	1/16W Metal Oxide	AA					
R204	VRS-CY1JF270JY	X 27	1/16W Metal Oxide	AA					
R205	VRS-CY1JF331JY	X 33k	1/16W Metal Oxide	AA					
R206	VRD-RA2BE101JY	X 100	1/8W Carbon	AA					
R211	VRS-CY1JF221JY	X 22k	1/16W Metal Oxide	AA					
R212	VRS-CY1JF221JY	X 22k	1/16W Metal Oxide	AA					
R225	VRS-CY1JF101JY	X 100	1/16W Metal Oxide	AA					
R226	VRS-CY1JF101JY	X 100	1/16W Metal Oxide	AA					
R227	VRS-CY1JF273JY	X 27k	1/16W Metal Oxide	AA					
R232	VRS-CY1JF471JY	X 47k	1/16W Metal Oxide	AA					
R234	VRD-RA2BE271JY	X 270	1/8W Carbon	AA					
R236	VRS-CY1JF332JY	X 3.3k	1/16W Metal Oxide	AA					
R301	VRS-CY1JF222JY	X 2.2k	1/16W Metal Oxide	AA					
R305	VRS-CY1JF000JY	X 0	1/16W Metal Oxide	AA					
R306	VRS-CY1JF102JY	X 1k	1/16W Metal Oxide	AA					
R307	VRS-CY1JF101JY	X 100	1/16W Metal Oxide	AA					
R308	VRS-CY1JF000JY	X 0	1/16W Metal Oxide	AA					
R355	VRD-RA2BE821JY	X 820	1/8W Carbon	AA					
R361	VRD-RA2BE224JY	X 220k	1/8W Carbon	AA					
R362	VRS-CY1JF222JY	X 2.2k	1/16W Metal Oxide	AA					
R363	VRS-CY1JF222JY	X 2.2k	1/16W Metal Oxide	AA					
R364	VRD-RA2BE152J								

Ref. No.	Part No.	★	Description	Code	Ref. No.	Part No.	★	Description	Code
R610	VRD-RM2HD220JY	X 22	1/2W Carbon	AA	R806	VRS-CY1JF681JY	X 680	1/16W Metal Oxide	AA
△ R611	VRW-KQ41C3R3K	X 3.3	15W Cement	AB	R807	VRS-CY1JF681JY	X 680	1/16W Metal Oxide	AA
R612	VRS-CY1JF154JY	X 150k	1/16W Metal Oxide	AA	R808	VRS-CY1JF681JY	X 680	1/16W Metal Oxide	AA
R613	VRS-CY1JF101JY	X 100	1/16W Metal Oxide	AA	R810	VRS-CY1JF472JY	X 4.7k	1/16W Metal Oxide	AA
R614	VRS-CY1JF562JY	X 5.6k	1/16W Metal Oxide	AA	R903	VRS-CY1JF102JY	X 1k	1/16W Metal Oxide	AA
R618	VRS-CY1JF101JY	X 100	1/16W Metal Oxide	AA	R904	VRS-CY1JF683JY	X 68k	1/16W Metal Oxide	AA
△ R621	VRN-RL3AB4R7J+	X 4.7	1W Metal Film	AB	R905	VRS-CY1JF223JY	X 22k	1/16W Metal Oxide	AA
△ R622	VRN-RL3ABR33J+	X 0.33	1W Metal Film	AB	R906	VRD-RA2BE332JY	X 3.3k	1/8W Carbon	AA
△ R623	VRN-RL3AB4R7J+	X 4.7	1W Metal Film	AB	R907	VRS-CY1JF152JY	X 1.5k	1/16W Metal Oxide	AA
△ R624	VRS-RG3DB332J+	X 3.3k	2W Metal Oxide	AB	R908	VRS-CY1JF102JY	X 1k	1/16W Metal Oxide	AA
△ R627	VRN-RL3ABR47J+	X 0.47	1W Metal Film	AB	R910	VRD-RA2BE102JY	X 1k	1/8W Carbon	AA
△ R628	VRN-RL3ABR47J+	X 0.47	1W Metal Film	AB	R911	VRS-CY1JF683JY	X 68k	1/16W Metal Oxide	AA
▲ R651	VRS-RG2HC270J+	X 27	1/2W Metal Oxide	AB	R912	VRS-CY1JF223JY	X 22k	1/16W Metal Oxide	AA
▲ R652	VRD-RA2EE103GY	X 10k	1/4W Carbon	AA	R913	VRS-CY1JF332JY	X 3.3k	1/16W Metal Oxide	AA
▲ R653	VRD-RA2EE562GY	X 5.6k	1/4W Carbon	AA	R914	VRS-CY1JF152JY	X 1.5k	1/16W Metal Oxide	AA
▲ R654	VRD-RA2BE683JY	X 68k	1/8W Carbon	AA	R915	VRS-CY1JF102JY	X 1k	1/16W Metal Oxide	AA
△ R658	VRS-RG3DB183J+	X 18k	2W Metal Oxide	AB	R916	VRS-CY1JF683JY	X 68k	1/16W Metal Oxide	AA
R663	VRS-CY1JF102JY	X 1k	1/16W Metal Oxide	AA	R917	VRS-CY1JF332JY	X 3.3k	1/16W Metal Oxide	AA
R670	VRS-CY1JF000JY	X 0	1/16W Metal Oxide	AA	R918	VRS-CY1JF332JY	X 3.3k	1/16W Metal Oxide	AA
R684	VRD-RA2BE472JY	X 4.7k	1/8W Carbon	AA	R922	VRS-CY1JF102JY	X 1k	1/16W Metal Oxide	AA
R685	VRD-RA2BE822JY	X 8.2k	1/8W Carbon	AA	R923	VRS-CY1JF102JY	X 1k	1/16W Metal Oxide	AA
R686	VRD-RA2EE332JY	X 3.3k	1/4W Carbon	AA	R924	VRS-CY1JF750JY	X 75	1/16W Metal Oxide	AA
R687	VRD-RA2BE103JY	X 10k	1/8W Carbon	AA	R925	VRS-CY1JF750JY	X 75	1/16W Metal Oxide	AA
△ R688	VRN-RL3DB3R3J+	X 3.3	2W Metal Film	AB	R926	VRS-CY1JF680JY	X 68	1/16W Metal Oxide	AA
R689	VRD-RM2HD824JY	X 820k	1/2W Carbon	AA	R927	VRS-CY1JF750JY	X 75	1/16W Metal Oxide	AA
△ R690	VRS-RG3LB122J+	X 1.2k	3W Metal Oxide	AB	R929	VRS-CY1JF473JY	X 47k	1/16W Metal Oxide	AA
R691	VRS-CY1JF394JY	X 390k	1/16W Metal Oxide	AA	R930	VRS-CY1JF473JY	X 47k	1/16W Metal Oxide	AA
R692	VRS-CY1JF183JY	X 18k	1/16W Metal Oxide	AA	R931	VRS-CY1JF750JY	X 75	1/16W Metal Oxide	AA
R693	VRS-CY1JF683JY	X 68k	1/16W Metal Oxide	AA	R932	VRS-CY1JF473JY	X 47k	1/16W Metal Oxide	AA
R694	VRS-CY1JF102JY	X 1k	1/16W Metal Oxide	AA	R933	VRS-CY1JF473JY	X 47k	1/16W Metal Oxide	AA
R695	VRS-CY1JF683JY	X 68k	1/16W Metal Oxide	AA	R934	VRS-CY1JF103JY	X 10k	1/16W Metal Oxide	AA
R696	VRS-CY1JF000JY	X 0	1/16W Metal Oxide	AA	R935	VRS-CY1JF101JY	X 100	1/16W Metal Oxide	AA
R697	VRS-CY1JF684JY	X 680k	1/16W Metal Oxide	AA	R936	VRS-CY1JF223JY	X 22k	1/16W Metal Oxide	AA
R698	VRS-CY1JF335JY	X 3.3M	1/16W Metal Oxide	AA	R937	VRS-CY1JF101JY	X 100	1/16W Metal Oxide	AA
△ R703	VRW-KQ4AC1R2K	X 1.2	10W Cement	AB	R938	VRS-CY1JF223JY	X 22k	1/16W Metal Oxide	AA
△ R705	VRN-RL3DBR15J+	X 0.15	2W Metal Film	AB	R939	VRS-CY1JF333JY	X 33k	1/16W Metal Oxide	AA
△ R706	VRN-RL3DBR15J+	X 0.15	2W Metal Film	AB	R940	VRS-CY1JF8R2JY	X 8.2	1/16W Metal Oxide	AA
R707	VRD-RM2HD270JY	X 27	1/2W Carbon	AA	R941	VRS-CY1JF101JY	X 100	1/16W Metal Oxide	AA
R708	VRS-CY1JF102JY	X 1k	1/16W Metal Oxide	AA	R942	VRS-CY1JF223JY	X 22k	1/16W Metal Oxide	AA
R709	VRS-CY1JF393JY	X 39k	1/16W Metal Oxide	AA	R943	VRS-CY1JF101JY	X 100	1/16W Metal Oxide	AA
△ R710	VRS-RG2HC103J+	X 10k	1/2W Metal Oxide	AB	R944	VRS-CY1JF223JY	X 22k	1/16W Metal Oxide	AA
R711	VRS-CY1JF334JY	X 330k	1/16W Metal Oxide	AA	R945	VRS-CY1JF101JY	X 100	1/16W Metal Oxide	AA
R712	VRD-RM2HD100JY	X 10	1/2W Carbon	AA	R946	VRS-CY1JF103JY	X 10k	1/16W Metal Oxide	AA
△ R713	VRS-RG2HC152J+	X 1.5k	1/2W Metal Oxide	AB	R947	VRS-CY1JF223JY	X 22k	1/16W Metal Oxide	AA
R714	VRS-CY1JF332JY	X 3.3k	1/16W Metal Oxide	AA	R948	VRS-CY1JF101JY	X 100	1/16W Metal Oxide	AA
R715	VRN-RL2HCR56J+	X 0.56	1/2W Metal Film	AB	R949	VRS-CY1JF223JY	X 22k	1/16W Metal Oxide	AA
R716	VRD-RM2HD100JY	X 10	1/2W Carbon	AA	R950	VRS-CY1JF560JY	X 56	1/16W Metal Oxide	AA
R720	VRD-RA2BE473JY	X 47k	1/8W Carbon	AA	R951	VRD-RA2BE680JY	X 68	1/8W Carbon	AA
R724	VRD-RM2HD101JY	X 100	1/2W Carbon	AA	R952	VRS-CY1JF333JY	X 33k	1/16W Metal Oxide	AA
R725	VRD-RM2HD821JY	X 820	1/2W Carbon	AA	R953	VRS-CY1JF220JY	X 22	1/16W Metal Oxide	AA
R734	VRD-RM2HD124JY	X 120k	1/2W Carbon	AA	R954	VRS-CY1JF221JY	X 220	1/16W Metal Oxide	AA
△ R737	VRN-RL3LBR82J+	X 0.82	3W Metal Film	AB	R955	VRS-CY1JF221JY	X 220	1/16W Metal Oxide	AA
R742	VRD-RA2BE222JY	X 2.2k	1/8W Carbon	AA	R957	VRS-CY1JF101JY	X 100	1/16W Metal Oxide	AA
R743	VRD-RM2HD470JY	X 47	1/2W Carbon	AA	R958	VRS-CY1JF101JY	X 100	1/16W Metal Oxide	AA
R744	VRS-CY1JF103JY	X 10k	1/16W Metal Oxide	AA	R959	VRS-CY1JF103JY	X 10k	1/16W Metal Oxide	AA
R745	VRD-RA2BE683JY	X 68k	1/8W Carbon	AA	R960	VRS-CY1JF101JY	X 100	1/16W Metal Oxide	AA
R750	VRS-CY1JF224JY	X 220k	1/16W Metal Oxide	AA	R961	VRS-CY1JF102JY	X 1k	1/16W Metal Oxide	AA
R751	VRD-RA2BE473JY	X 47k	1/8W Carbon	AA	R962	VRS-CY1JF332FY	X 3.3k	1/16W Metal Oxide	AA
R752	VRD-RA2BE392JY	X 3.9k	1/8W Carbon	AA	R963	VRD-RA2BE101JY	X 100	1/8W Carbon	AA
R753	VRS-CY1JF223JY	X 22k	1/16W Metal Oxide	AA	R964	VRS-CY1JF101JY	X 100	1/16W Metal Oxide	AA
R754	VRS-CY1JF222JY	X 2.2k	1/16W Metal Oxide	AA	R967	VRS-CY1JF682JY	X 6.8k	1/16W Metal Oxide	AA
R755	VRS-CY1JF473JY	X 47k	1/16W Metal Oxide	AA	R968	VRS-CY1JF102JY	X 1k	1/16W Metal Oxide	AA
R756	VRD-RA2BE152JY	X 1.5k	1/8W Carbon	AA	R969	VRS-CY1JF472FY	X 4.7k	1/16W Metal Oxide	AA
△ R757	VRN-RL3DBR4R7J+	X 4.7	2W Metal Film	AB	R970	VRD-RA2BE6R8JY	X 6.8	1/8W Carbon	AA
R759	VRS-CY1JF103JY	X 10k	1/16W Metal Oxide	AA	R971	VRS-CY1JF101JY	X 100	1/16W Metal Oxide	AA
R761	VRS-CY1JF332JY	X 3.3k	1/16W Metal Oxide	AA	R972	VRS-CY1JF101JY	X 100	1/16W Metal Oxide	AA
R762	VRD-RA2EE151JY	X 150	1/4W Carbon	AA	R973	VRS-CY1JF000JY	X 0	1/16W Metal Oxide	AA
R764	VRD-RM2HDS62JY	X 5.6k	1/2W Carbon	AA	R974	VRS-CY1JF103JY	X 10k	1/16W Metal Oxide	AA
R767	VRD-RM2HD151JY	X 150	1/2W Carbon	AA	R975	VRS-CY1JF333JY	X 33k	1/16W Metal Oxide	AA
R768	VRD-RA2BE393JY	X 39k	1/8W Carbon	AA	R983	VRS-CY1JF473JY	X 47k	1/16W Metal Oxide	AA
R775	VRS-CY1JF332JY	X 3.3k	1/16W Metal Oxide	AA	R984	VRS-CY1JF473JY	X 47k	1/16W Metal Oxide	AA
R776	VRS-CY1JF332JY	X 3.3k	1/16W Metal Oxide	AA	△ R1420	VRN-RL3LB2R7J+	X 2.7	3W Metal Film	AB
R801	VRS-CY1JF333JY	X 33k	1/16W Metal Oxide	AA	R2001	VRS-CY1JF102JY	X 1k	1/16W Metal Oxide	AA
R802	VRS-CY1JF471JY	X 470	1/16W Metal Oxide	AA	R2004	VRS-CY1JF101JY	X 100	1/16W Metal Oxide	AA
R803	VRS-CY1JF000JY	X 0	1/16W Metal Oxide	AA	R2008	VRS-CY1JF102JY	X 1k	1/16W Metal Oxide	AA
R805	VRS-CY1JF682JY	X 6.8k	1/16W Metal Oxide	AA	R2010	VRS-CY1JF102JY	X 1k	1/16W Metal Oxide	AA

Ref. No.	Part No.	★	Description	Code	Ref. No.	Part No.	★	Description	Code
R2013	VRS-CY1JF682JY	X	6.8k 1/16W Metal Oxide	AA	J921	QSOCD0456CEZZ	X	Socket, S-Video	AC
R2021	VRS-CY1JF334JY	X	330k 1/16W Metal Oxide	AA	J1401	QTANJ1101SEZZ	X	In Out Jack	AF
R2024	VRS-CY1JF472JY	X	4.7k 1/16W Metal Oxide	AA	P361	QPLGN0461CEZZA	X	Plug, 4Pin(S)	AB
R2025	VRS-CY1JF472JY	X	4.7k 1/16W Metal Oxide	AA	P401	QPLGN0861CEZZA	X	Plug, 8Pin(CJ)	AB
R2026	VRS-CY1JF472JY	X	4.7k 1/16W Metal Oxide	AA	P601	QPLGN0161FJZZ	X	Plug, 6Pin(K)	AB
R2027	VRS-CY1JF102JY	X	1k 1/16W Metal Oxide	AA	P621	QPLGN0761CEZZA	X	Plug, 7Pin(N)	AB
R2028	VRD-RA2BE102JY	X	1k 1/8W Carbon	AA	P651	QPLGN0361CEZZA	X	Plug, 3Pin(TP651-3)	AB
R2031	VRS-CY1JF222JY	X	2.2k 1/16W Metal Oxide	AA	P702	QPLGN0269GEZZ	X	Plug, 2Pin(P)	AB
R2033	VRS-CY1JF334JY	X	330k 1/16W Metal Oxide	AA	P703	QPLGN0260CEZZ	X	Plug, 2Pin(M)	AB
R2040	VRS-CY1JF102JY	X	1k 1/16W Metal Oxide	AA	P1301	QPLGN0661CEZZA	X	Plug, 6Pin(EJ)	AB
R2041	VRS-CY1JF333JY	X	33k 1/16W Metal Oxide	AA	P2003	QPLGN0561CEZZA	X	Plug, 5Pin(KA)	AB
R2042	VRS-CY1JF101JY	X	100 1/16W Metal Oxide	AA	P2401	QPLGN0661CEZZA	X	Plug, 6Pin	AB
R2043	VRS-CY1JF333JY	X	33k 1/16W Metal Oxide	AA	RDA361	PRDAR0258PEFW	X	Heat Sink for IC361	AC
R2044	VRS-CY1JF153JY	X	15k 1/16W Metal Oxide	AA	RDA501	PRDARA039WJFW	X	Heat Sink for IC501	AD
R2045	VRS-CY1JF473JY	X	47k 1/16W Metal Oxide	AA	RDA601	PRDARA041WJFW	X	Heat Sink for Q602	AD
R2046	VRS-CY1JF101JY	X	100 1/16W Metal Oxide	AA	RDA671	PRDARA057WJFW	X	Heat Sink for Q673	AC
R2047	VRS-CY1JF221JY	X	220 1/16W Metal Oxide	AA	RDA701	PRDAR0279PEFW	X	Heat Sink for Q701	AB
R2048	VRS-CY1JF562JY	X	5.6k 1/16W Metal Oxide	AA	RDA750	PRDAR5072CEFW	X	Heat Sink for IC751	AB
R2051	VRS-CY1JF102JY	X	1k 1/16W Metal Oxide	AA	RDA1403	PRDAR5072CEFW	X	Heat Sink for IC1403	AB
R2054	VRS-CY1JF102JY	X	1k 1/16W Metal Oxide	AA	△ RY701	RRLYJ0081CEZZ	X	Relay	AD
R2060	VRS-CY1JF221JY	X	220 1/16W Metal Oxide	AA	RY702	RRLYJ0088CEZZ	X	Relay	AC
R2061	VRS-CY1JF562JY	X	5.6k 1/16W Metal Oxide	AA	CF2040	RCRM-0003CEZZ+	X	Ceramic Vibrator	AC
R2062	VRS-CY1JF223JY	X	22k 1/16W Metal Oxide	AA	TP701	QLUGP0102PEZZ	X	Lug	AA
R2063	VRS-CY1JF222JY	X	2.2k 1/16W Metal Oxide	AA					
R2064	VRS-CY1JF332JY	X	3.3k 1/16W Metal Oxide	AA					
R2073	VRS-CY1JF000JY	X	0 1/16W Metal Oxide	AA					
R2084	VRS-CY1JF103JY	X	10k 1/16W Metal Oxide	AA					
R2086	VRS-CY1JF101JY	X	100 1/16W Metal Oxide	AA					
R2088	VRS-CY1JF224JY	X	220k 1/16W Metal Oxide	AA					
R2089	VRS-CY1JF273JY	X	27k 1/16W Metal Oxide	AA					
R2090	VRS-CY1JF682JY	X	6.8k 1/16W Metal Oxide	AA					
R2092	VRS-CY1JF101JY	X	100 1/16W Metal Oxide	AA					
R2093	VRS-CY1JF224JY	X	220k 1/16W Metal Oxide	AA					
R2094	VRS-CY1JF473JY	X	47k 1/16W Metal Oxide	AA					
R2095	VRS-CY1JF101JY	X	100 1/16W Metal Oxide	AA					
R2096	VRS-CY1JF101JY	X	100 1/16W Metal Oxide	AA					
R2101	VRS-CY1JF101JY	X	100 1/16W Metal Oxide	AA					
R2102	VRS-CY1JF101JY	X	100 1/16W Metal Oxide	AA					
R2201	VRS-CY1JF222JY	X	2.2k 1/16W Metal Oxide	AA					
R2202	VRS-CY1JF103JY	X	10k 1/16W Metal Oxide	AA					
R2203	VRS-CY1JF473JY	X	47k 1/16W Metal Oxide	AA					
R2211	VRS-CY1JF222JY	X	2.2k 1/16W Metal Oxide	AA					
R2212	VRS-CY1JF682JY	X	6.8k 1/16W Metal Oxide	AA					
R2213	VRS-CY1JF333JY	X	33k 1/16W Metal Oxide	AA					
R2401	VRD-RA2BE101JY	X	100 1/8W Carbon	AA					
R2402	VRD-RA2BE101JY	X	100 1/8W Carbon	AA					
R2403	VRD-RA2BE101JY	X	100 1/8W Carbon	AA					
R2404	VRD-RA2BE101JY	X	100 1/8W Carbon	AA					
R2501	VRS-CY1JF183JY	X	18k 1/16W Metal Oxide	AA					
R2502	VRS-CY1JF183JY	X	18k 1/16W Metal Oxide	AA					
R2503	VRS-CY1JF103JY	X	10k 1/16W Metal Oxide	AA					
R2504	VRS-CY1JF103JY	X	10k 1/16W Metal Oxide	AA					
R2509	VRS-CY1JF000JY	X	0 1/16W Metal Oxide	AA					
R3001	VRS-CY1JF221JY	X	220 1/16W Metal Oxide	AA					
R3002	VRS-CY1JF221JY	X	220 1/16W Metal Oxide	AA					
R3003	VRS-CY1JF105JY	X	1M 1/16W Metal Oxide	AA					
R3004	VRS-CY1JF104JY	X	100k 1/16W Metal Oxide	AA					
R3005	VRS-CY1JF623JY	X	62k 1/16W Metal Oxide	AA					
R3007	VRS-CY1JF332JY	X	3.3k 1/16W Metal Oxide	AA					
R3008	VRS-CY1JF302JY	X	3k 1/16W Metal Oxide	AA					
R3010	VRS-CY1JF392JY	X	3.9k 1/16W Metal Oxide	AA					
R3017	VRS-CY1JF102JY	X	1k 1/16W Metal Oxide	AA					
R3018	VRS-CY1JF102JY	X	1k 1/16W Metal Oxide	AA					
R3019	VRS-CY1JF101JY	X	100 1/16W Metal Oxide	AA					
R3024	VRD-RA2BE102JY	X	1k 1/8W Carbon	AA					
BALUNES									
FB601	RBLN-0047CEZZY	X	Balun	AB					
FB706	RBLN-0037CEZZY	X	Balun	AB					
FB2001	RBLN-0037CEZZY	X	Balun	AB					
MISCELLANEOUS PARTS									
△ ACC701	QACCCDA012WJPZ	X	AC Cord	AE					
FH701	QFSDH1013CEZZ+	X	Fuse Holder	AB					
FH702	QFSDH1014CEZZ+	X	Fuse Holder	AB					
△ F701	QFS-B4023CEZZ	X	Fuse, 4A/125V	AB					

DUNTKA527WEW7 PWB-B CRT UNIT

INTEGRATED CIRCUIT

△ IC850 VHTDA6103Q-1 X TDA6103Q/N3 AG

TRANSISTORS

Q850	VS2SA1266-Y-1+	X	2SA1266-Y	AB
Q851	VS2SC3198-G-1+	X	2SC3198-G	AB
Q1504	VS2SC3198-G-1+	X	2SC3198-G	AB
Q1505	VS2SA1266-Y-1+	X	2SA1266-Y	AB
Q1506	VS2SA1964E/-1	X	2SA1964E	AC
Q1507	VS2SC5248E/-1	X	2SC5248E	AC

DIODES

D850	RH-DX0220CEZZY	X	DX0220CE	AB
D851	RH-DX0220CEZZY	X	DX0220CE	AB
D852	RH-DX0220CEZZY	X	DX0220CE	AB
D853	RH-EX0647GEZZY	X	Zener Diode, 15V	AB
D854	VHD1SS119/-1Y	X	1SS119	AA
D855	VHD1SS119/-1Y	X	1SS119	AA
D862	VHD1SS119/-1Y	X	1SS119	AA
D1502	VHD1SS119/-1Y	X	1SS119	AA
D1503	VHD1SS119/-1Y	X	1SS119	AA
D1506	RH-DX0487CEZZY	X	DX0487CE	AB
D1507	RH-DX0487CEZZY	X	DX0487CE	AB
D1510	VHD1SS119/-1Y	X	1SS119	AA

CAPACITORS

C850	VCFYSB2EB224K	X	0.22 250V	AB
C851	RC-KZ018JCEZZ	X	0.01 AC250V Ceramic	AB
C852	VCEA0A1CW107M+X	X	100 16V Electrolytic	AB
C853	VCFYFA1HA224J+	X	0.22 50V Mylar	AB
C854	VCEA0A1CW227M+X	X	220 16V Electrolytic	AB
C855	VCEA0A2EW106M+X	X	10 250V Electrolytic	AB
C856	VCEA0A1HW226M+X	X	22 50V Electrolytic	AB
C1501	VCEA0A1CW476M+X	X	47 16V Electrolytic	AB
C1506	VCKYPA1HF103Z+	X	0.01 50V Ceramic	AA
C1508	VCKYPA2HB472K+	X	4700p 500V Ceramic	AB
C1509	VCKYPA1HB472K+	X	4700p 50V Ceramic	AB
C1510	VCKYPA1HF103Z+	X	0.01 50V Ceramic	AA
C1511	VCKYPA1HF103Z+	X	0.01 50V Ceramic	AA
C1515	VCEA0A1HW476M+X	X	47 50V Electrolytic	AB
C1516	VCEA0A1HW476M+X	X	47 50V Electrolytic	AB
C1517	VCEA0A2AW106M+X	X	10 100V Electrolytic	AB
C1518	VCCSPA2HL560K+	X	56p 500V Ceramic	AB
C1519	VCEA0A2CW106M+X	X	10 160V Electrolytic	AB

Ref. No.	Part No.	★	Description	Code	Ref. No.	Part No.	★	Description	Code
RESISTORS					CAPACITORS				
△ R850	VRS-SV2HC152J	X	1.5k 1/2W	Metal Oxide AB	C1401	VCKYCY1HB103KY X	0.01	50V	Ceramic AA
△ R851	VRS-SV2HC152J	X	1.5k 1/2W	Metal Oxide AB	C1402	VCEA0A1AW227M+X	220	10V	Electrolytic AB
△ R852	VRS-SV2HC152J	X	1.5k 1/2W	Metal Oxide AB	C1403	VCCCCY1HH330JY X	33p	50V	Ceramic AA
△ R853	VRS-SV2HC272J	X	2.7k 1/2W	Metal Oxide AB	C1404	VCCCCY1HH181JY X	180p	50V	Ceramic AB
△ R854	VRS-SV2HC272J	X	2.7k 1/2W	Metal Oxide AB	C1405	VCKYCY1HB103KY X	0.01	50V	Ceramic AA
△ R855	VRS-SV2HC272J	X	2.7k 1/2W	Metal Oxide AB	C1406	VCKYCY1HB103KY X	0.01	50V	Ceramic AA
R856	VRD-RM2HD104JY X		100k 1/2W	Carbon AA	C1407	VCKYCY1HB103KY X	0.01	50V	Ceramic AA
R857	VRD-RM2HD104JY X		100k 1/2W	Carbon AA	C1408	VCKYCY1HB103KY X	0.01	50V	Ceramic AA
R858	VRD-RM2HD104JY X		100k 1/2W	Carbon AA	C1409	VCEA0A1CW476M+X	47	16V	Electrolytic AB
R861	VRD-RM2HD104JY X		100k 1/2W	Carbon AA	C1410	VCKYCY1HB103KY X	0.01	50V	Ceramic AA
R862	VRC-MA2HG152KY X		1.5k 1/2W	Solid AB	C1411	VCKYCY1HB103KY X	0.01	50V	Ceramic AA
R863	VRC-MA2HG152KY X		1.5k 1/2W	Solid AB	C1412	VCKYCY1HB103KY X	0.01	50V	Ceramic AA
R864	VRC-MA2HG152KY X		1.5k 1/2W	Solid AB	C1413	VCKYCY1HB103KY X	0.01	50V	Ceramic AA
△ R867	VRS-SV2HC392J	X	3.9k 1/2W	Metal Oxide AB	C1414	VCE9GA1HW105M+X	1	50V	Electrolytic AB
△ R868	VRS-SV2HC682J	X	6.8k 1/2W	Metal Oxide AB	C1415	VCCCCY1HH120JY X	12p	50V	Ceramic AA
R869	VRD-RA2BE103JY X		10k 1/8W	Carbon AA	C1416	VCCCCY1HH3R0CYX	3p	50V	Ceramic AA
R870	VRD-RA2BE223JY X		22k 1/8W	Carbon AA	C1417	VCCCCY1HH270JY X	27p	50V	Ceramic AA
R871	VRD-RA2BE472JY X		4.7k 1/8W	Carbon AA	C1418	VCCCCY1HH120JY X	12p	50V	Ceramic AA
R872	VRD-RA2EE680JY X		68k 1/4W	Carbon AA	C1419	VCCCCY1HH3R0CYX	3p	50V	Ceramic AA
R873	VRD-RM2HD224JY X		22k 1/2W	Carbon AA	C1420	VCCCCY1HH270JY X	27p	50V	Ceramic AA
R874	VRD-RM2HD104JY X		100k 1/2W	Carbon AA	C1423	VCYFA1HA474J+ X	0.47	50V	Mylar AB
R875	VRD-RM2HD104JY X		100k 1/2W	Carbon AA	C1424	VCEA0A1CW107M+X	100	16V	Electrolytic AB
R876	VRD-RM2HD104JY X		100k 1/2W	Carbon AA	C1425	VCCCCY1HH820JY X	82p	50V	Ceramic AA
R877	VRD-RA2BE103JY X		10k 1/8W	Carbon AA	C1429	VCEA0A1CW107M+X	100	16V	Electrolytic AB
△ R878	VRS-SV2HC120J	X	12 1/2W	Metal Oxide AB	C1430	VCKYCY1CB104KY X	0.1	16V	Ceramic AA
R1511	VRD-RA2BE101JY X		100 1/8W	Carbon AA	C1431	VCKYCY1HB103KY X	0.01	50V	Ceramic AA
△ R1513	VRS-VV3DB561J	X	560 2W	Metal Oxide AB	C1432	VCKYCY1HB103KY X	0.01	50V	Ceramic AA
R1514	VRD-RA2BE100JY X		10 1/8W	Carbon AA	RESISTORS				
R1515	VRD-RA2BE820JY X		82 1/8W	Carbon AA	R1401	VRS-CY1JF821JY X	820	1/16W	Metal Oxide AA
R1516	VRD-RA2BE820JY X		82 1/8W	Carbon AA	R1402	VRS-CY1JF000JY X	0	1/16W	Metal Oxide AA
R1517	VRD-RA2BE122JY X		1.2k 1/8W	Carbon AA	R1403	VRS-CY1JF361JY X	360	1/16W	Metal Oxide AA
R1518	VRD-RA2BE683JY X		68k 1/8W	Carbon AA	R1415	VRS-CY1JF391JY X	390	1/16W	Metal Oxide AA
R1519	VRD-RA2BE123JY X		12k 1/8W	Carbon AA	R1416	VRS-CY1JF102JY X	1k	1/16W	Metal Oxide AA
R1520	VRD-RA2BE683JY X		68k 1/8W	Carbon AA	R1417	VRS-CY1JF152JY X	1.5k	1/16W	Metal Oxide AA
R1521	VRD-RA2BE122JY X		1.2k 1/8W	Carbon AA	R1421	VRS-CY1JF152FY X	1.5k	1/16W	Metal Oxide AA
R1525	VRD-RA2EE560JY X		56 1/4W	Carbon AA	R1423	VRS-CY1JF102FY X	1k	1/16W	Metal Oxide AA
R1526	VRD-RA2EE560JY X		56 1/4W	Carbon AA	R1427	VRS-CY1JF000JY X	0	1/16W	Metal Oxide AA
R1527	VRD-RM2HD1R5JY X		1.5 1/2W	Carbon AA	R1428	VRD-RA2BE332JY X	3.3k	1/8W	Carbon AA
R1528	VRD-RM2HD1R5JY X		1.5 1/2W	Carbon AA	R1429	VRS-CY1JF000JY X	0	1/16W	Metal Oxide AA
△ R1529	VRS-VV3DB221J	X	220 2W	Metal Oxide AB	R1430	VRS-CY1JF151JY X	150	1/16W	Metal Oxide AA
R1530	VRD-RA2BE122JY X		1.2k 1/8W	Carbon AA	MISCELLANEOUS PART				
BALUN					P1401	QPLGZ0810CEZZ	X	Plug, 8Pin(CJ)	AB
FB1501	RBLN-0020CEZZ+	X	Balun	AB	DUNTKB207WEA5 PWB-F CONTROL UNIT				
MISCELLANEOUS PARTS					CAPACITOR				
P854	QPLGN0741CEZZ	X	Plug, 7Pin(N)	AB	C4001	VCEA0A1HW476M+X	47	50V	Electrolytic AB
P860	QPLGN0841CEZZ	X	Plug, 8Pin(CJ)	AB	RESISTORS				
△ P861	QPLGN0241CEZZ	X	Plug	AB	R4001	VRD-RA2BE470JY X	47	1/8W	Carbon AA
RDA850	PRDAR0248PEFW	X	Heat Sink for IC850	AB	R4006	VRD-RA2BE822JY X	8.2k	1/8W	Carbon AA
RDA1506	PRDAR5072CEFW	X	Heat Sink for Q1506	AB	R4007	VRD-RA2BE822JY X	8.2k	1/8W	Carbon AA
RDA1507	PRDAR5072CEFW	X	Heat Sink for Q1507	AB	R4009	VRD-RA2BE183JY X	18k	1/8W	Carbon AA
SC850	QSOCV1011CEZZ	X	Socket, 12Pin	AC	R4011	VRD-RA2BE183JY X	18k	1/8W	Carbon AA
DUNTKB572WEV0 PWB-D 2 LINE Y/C UNIT					SWITCHES				
INTEGRATED CIRCUIT					S4001	QSW-KA003WJZZ+ X		Switch, POWER	AB
IC1401	VHiTC90A45F-1Y	X	TC90A45F	AH	S4002	QSW-KA003WJZZ+ X		Switch, MENU	AB
TRANSISTORS					S4003	QSW-KA003WJZZ+ X		Switch, VOL.-DOWN	AB
Q1401	VS2SD601AR/-1Y	X	2SD601AR	AB	S4004	QSW-KA003WJZZ+ X		Switch, VOL.-UP	AB
Q1402	VS2SD601AR/-1Y	X	2SD601AR	AB	S4005	QSW-KA003WJZZ+ X		Switch, CH-DOWN	AB
Q1404	VS2SB709AR/-1Y	X	2SB709AR	AB	S4006	QSW-KA003WJZZ+ X		Switch, CH-UP	AB
COILS					MISCELLANEOUS PARTS				
L1401	VP-XF100K0000Y	X	Peaking, 10μH	AB	J4001	QJAKGA031WJZZ	X	Input-2 Jack	AC
L1402	VP-XF100K0000Y	X	Peaking, 10μH	AB	P4001	QPLGN0641CEZZ	X	Plug, 6Pin(EJ)	AB
L1403	VP-XF100K0000Y	X	Peaking, 10μH	AB	P4004	QPLGN0541CEZZ	X	Plug, 5Pin(KA)	AB
L1404	VP-XF220K0000Y	X	Peaking, 22μH	AB	RMC4001	RRMCU0222CEZZ	X	Remote Receiver	AD
L1405	VP-XF220K0000Y	X	Peaking, 22μH	AB					
L1408	VP-XF100K0000Y	X	Peaking, 10μH	AB					

Ref. No.	Part No.	★	Description	Code
----------	----------	---	-------------	------

MISCELLANEOUS PARTS

SP1	VSP1206PB648A	X	Speaker(L)	AG
SP2	VSP1206PB648A	X	Speaker(R)	AG
	QCNW-A475WJZZ	X	Connecting Cord	AC
	QCNW-B175WJZZ	X	Connecting Cord	AC
	QCNW-B176WJZZ	X	Connecting Cord	AC
	QCNW-B240WJZZ	X	Connecting Cord	AE
	QCNW-B241WJZZ	X	Connecting Cord	AB

SUPPLIED ACCESSORIES

RRMCGA035WJSB	X	Infrared R-C Unit	AR
TGAN-A216WJN1	X	Guarantee Card	AB
TINS-B092WJZZ	X	Operation Manual	

PACKING PARTS (NOT REPLACEMENT ITEM)

SPAKCB276WJZZ	-	Packing Case	—
SPAKCA590WJZZ	-	Packing Case	—
SPAKP0110GJZZ	-	Wrapping Paper	—
SPAKX0131GJZZ	-	Packing Add.	—
SSAKA0101GJZZ	-	Polyethylene Bag	—

Ref. No.	Part No.	★	Description	Code
----------	----------	---	-------------	------

CABINET PARTS

1B	CCABA0176WEH6	X	Front Cabinet Ass'y	
1B-1	<i>Not Available</i>	-	Front Cabinet	—
1B-2	HBDGB3141CESA	X	Badge	AD
1B-3	HDECQ0105GJKA	X	Decoration Plate	AF
1B-4	JBTN-0128GJKA	X	Button	AC
1B-5	GDORF0105GJKD	X	Door	
1B-6	HiNDP0107GJSA	X	Indicator	AB
1B-7	HDECQ0104GJKA	X	Decoration Plate	AF
1B-8	JBTN-0129GJKA	X	Button	AB
2B	GCABB0160GJKB	X	Rear Cabinet	BB

CABINET PARTS LOCATION

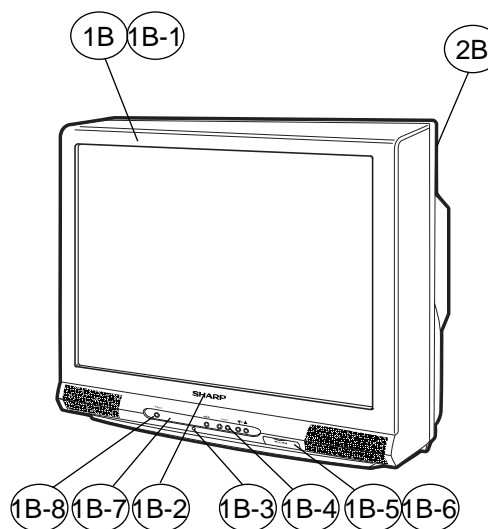

PACKING OF THE SET

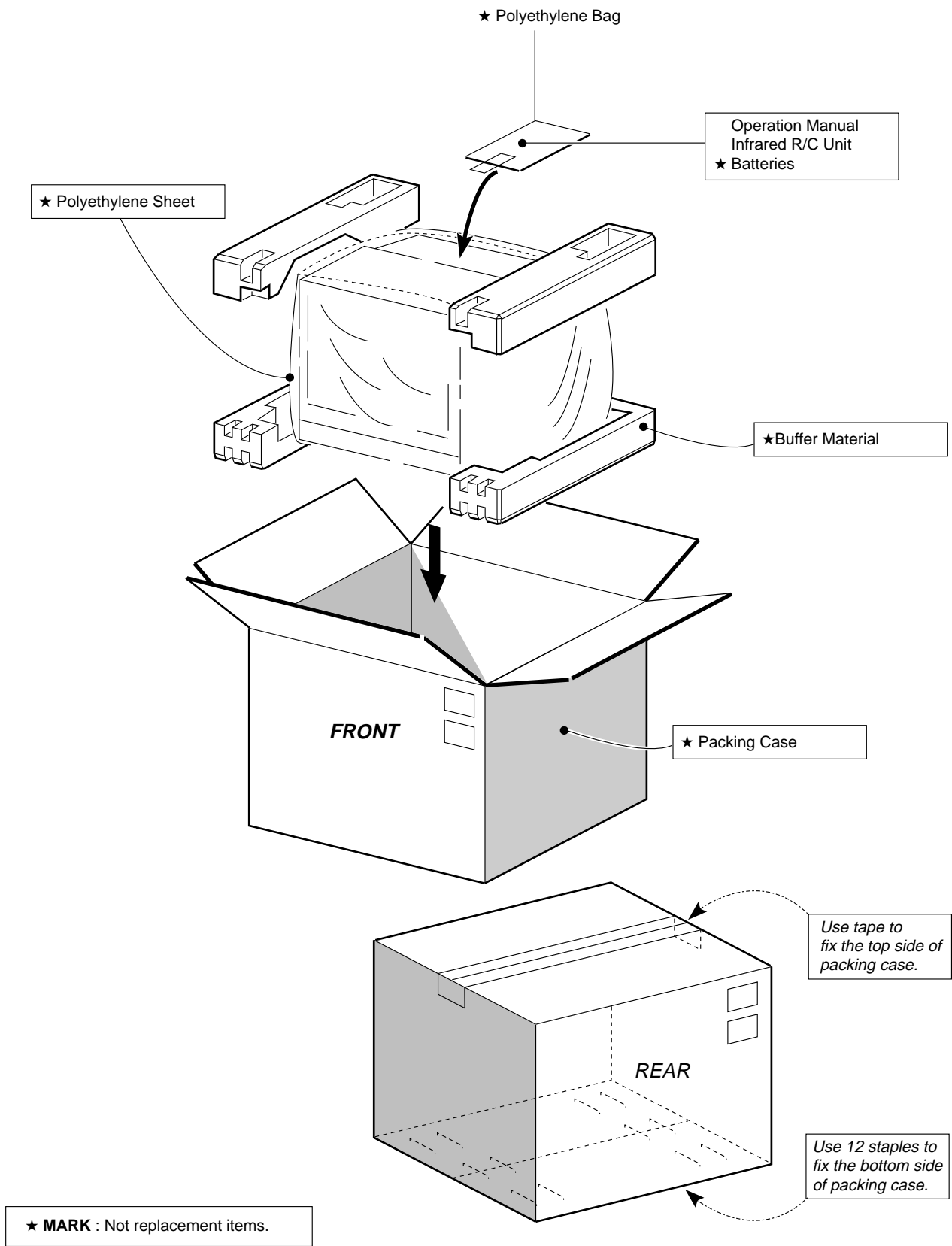

SHARP

COPYRIGHT © 2004 BY SHARP CORPORATION

ALL RIGHTS RESERVED.

No part of this publication may be reproduced, stored in a retrieval system, or transmitted in any form or by any means, electronic, mechanical, photocopying, recording, or otherwise, without prior written permission of the publisher.

TQ1703-S
Feb. 2004 Printed in Japan
In Japan gedruckt

Design and Production Information
Design : JAPAN
Production : SEMEX

MY. DS

SHARP CORPORATION
AV Systems Group
Quality & Reliability Control Center
Yaita, Tochigi 329-2193, Japan