

12 SCHEMATIC DIAGRAMS

12.1. OVER ALL BLOCK DIAGRAM

◆ OVERALL BLOCK DIAGRAM

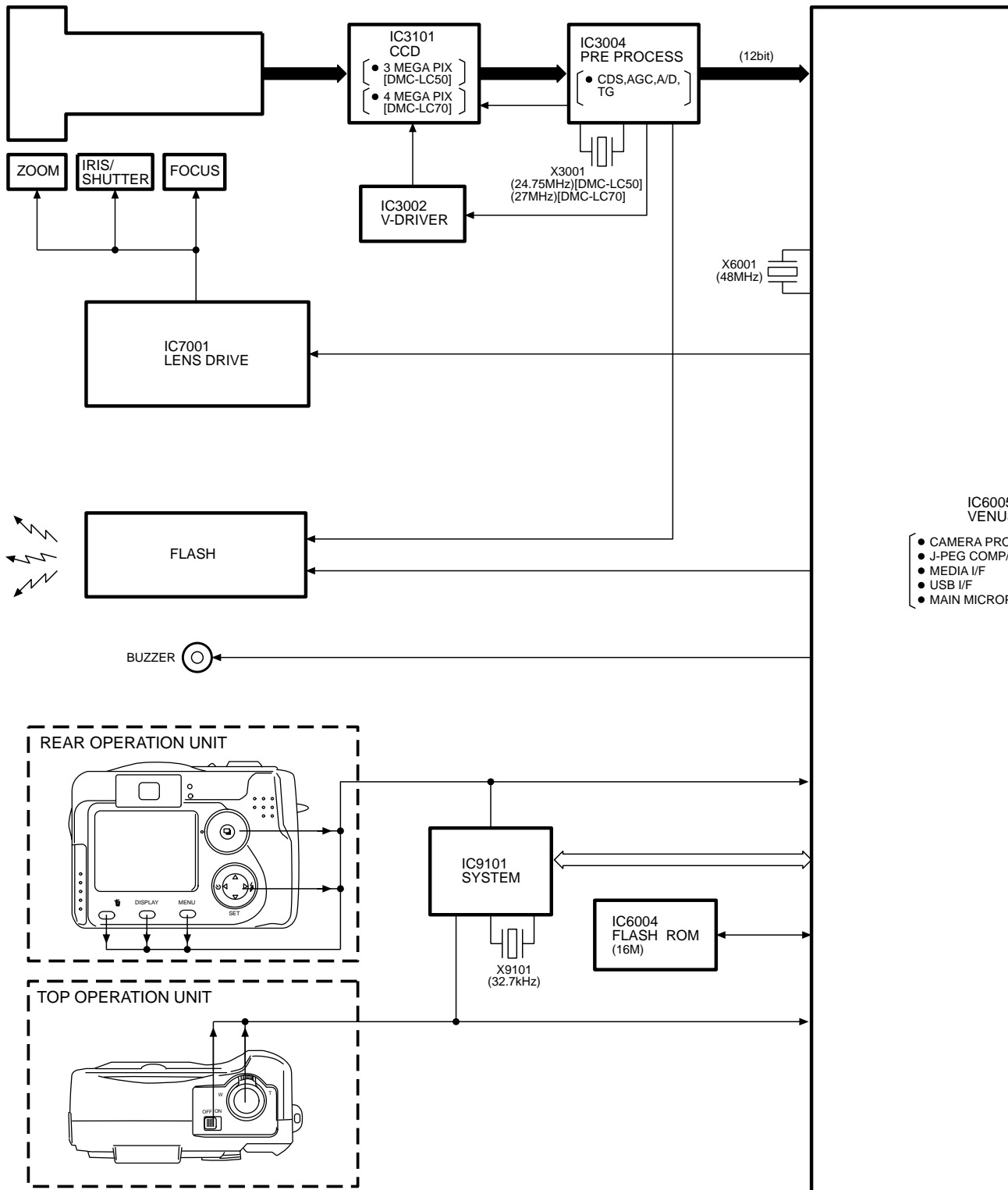

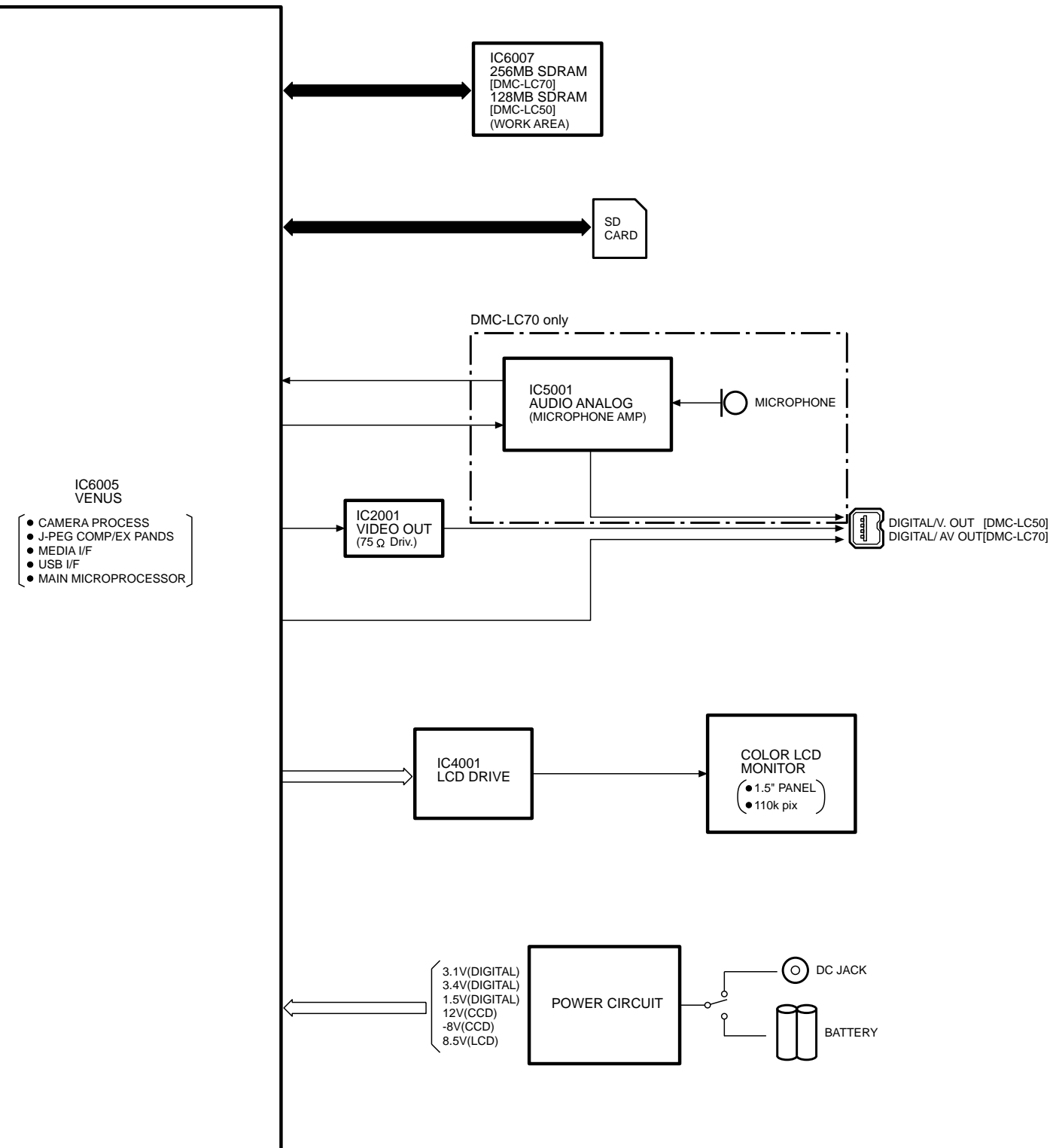

DMC-LC50/LC70PP/PL/EB/EG/EGM/GC/GD/GN OVERALL BLOCK DIAGRAM

12.2. WIRING CONNECTION DIAGRAM

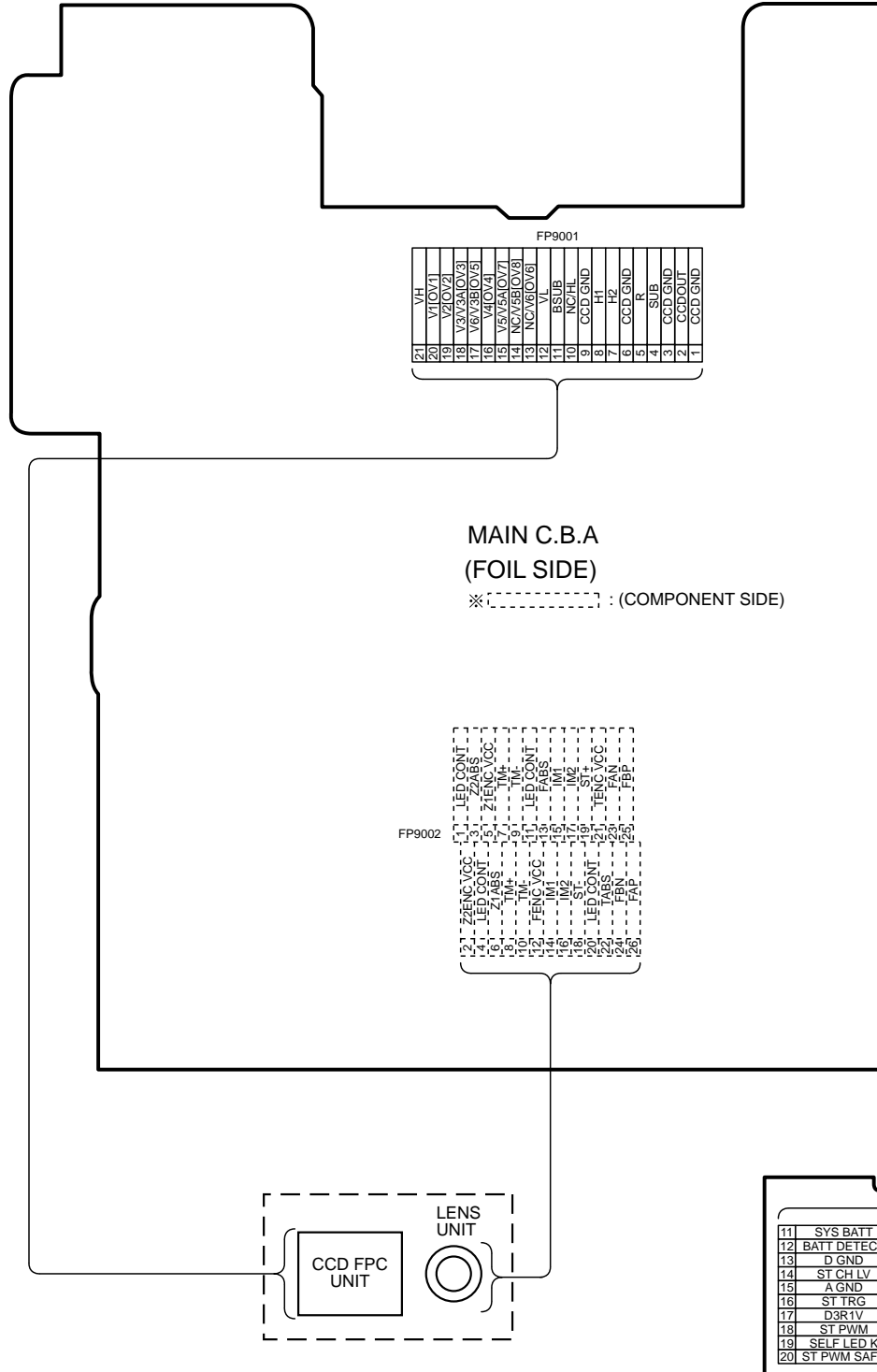

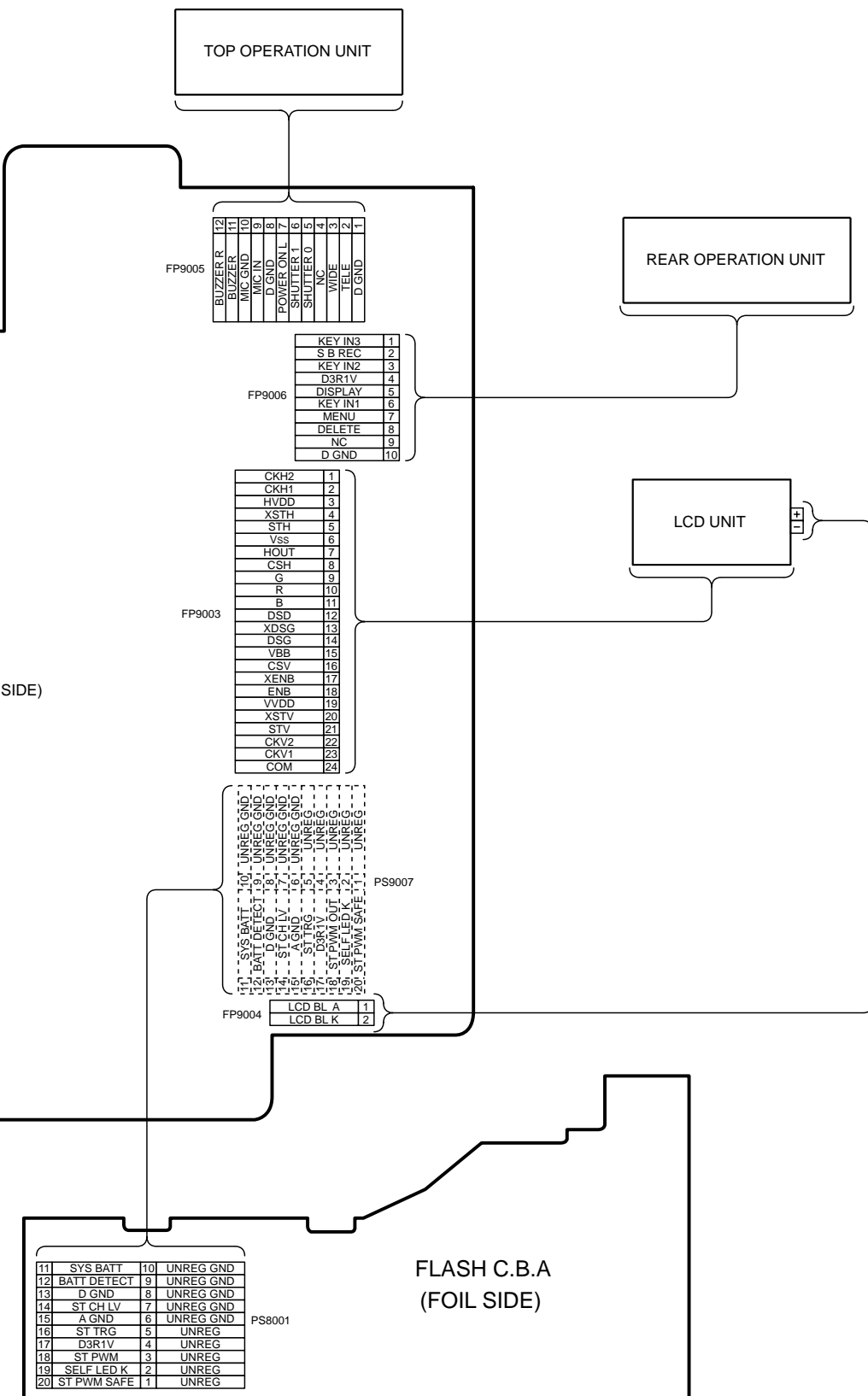

SIDE)

DMC-LC50/LC70PP/PL/EB/EG/EGM/GC/GD/GN WIRING CONNECTION DIAGRAM



12.3. FLASH SCHEMATIC DIAGRAM

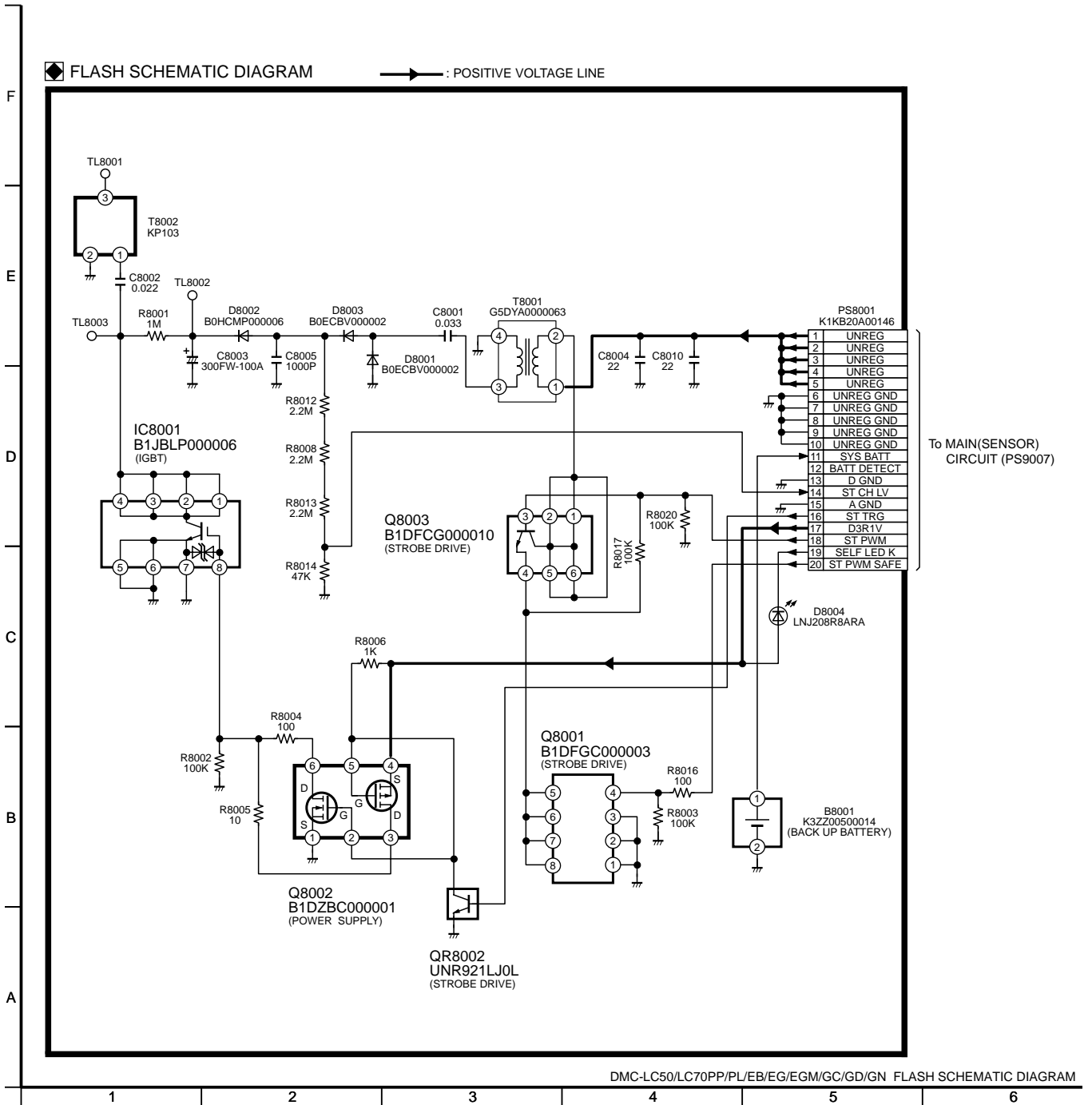

12.4. CCD SCHEMATIC DIAGRAM (DMC-LC50)

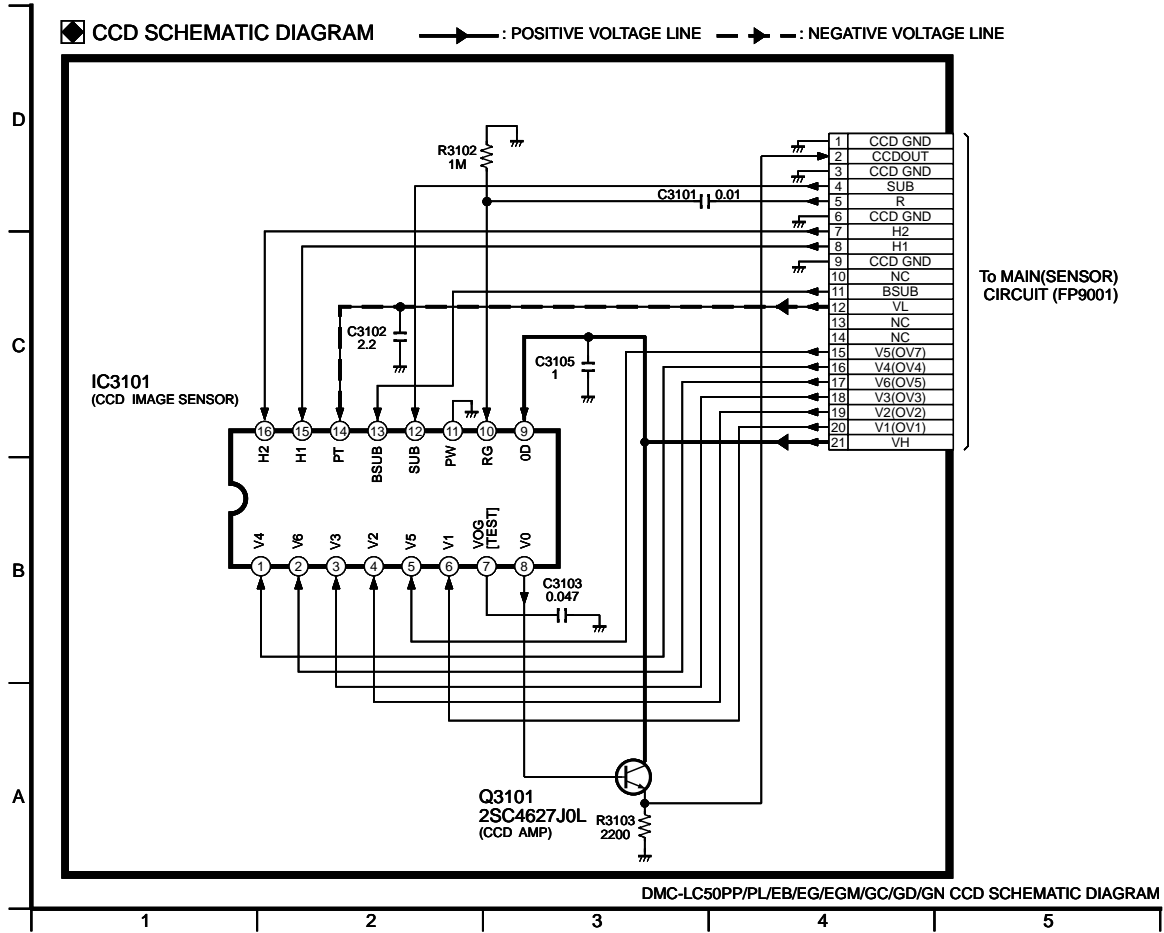

R)
0007)

DIAGRAM

12.5. CCD SCHEMATIC DIAGRAM (DMC-LC70)

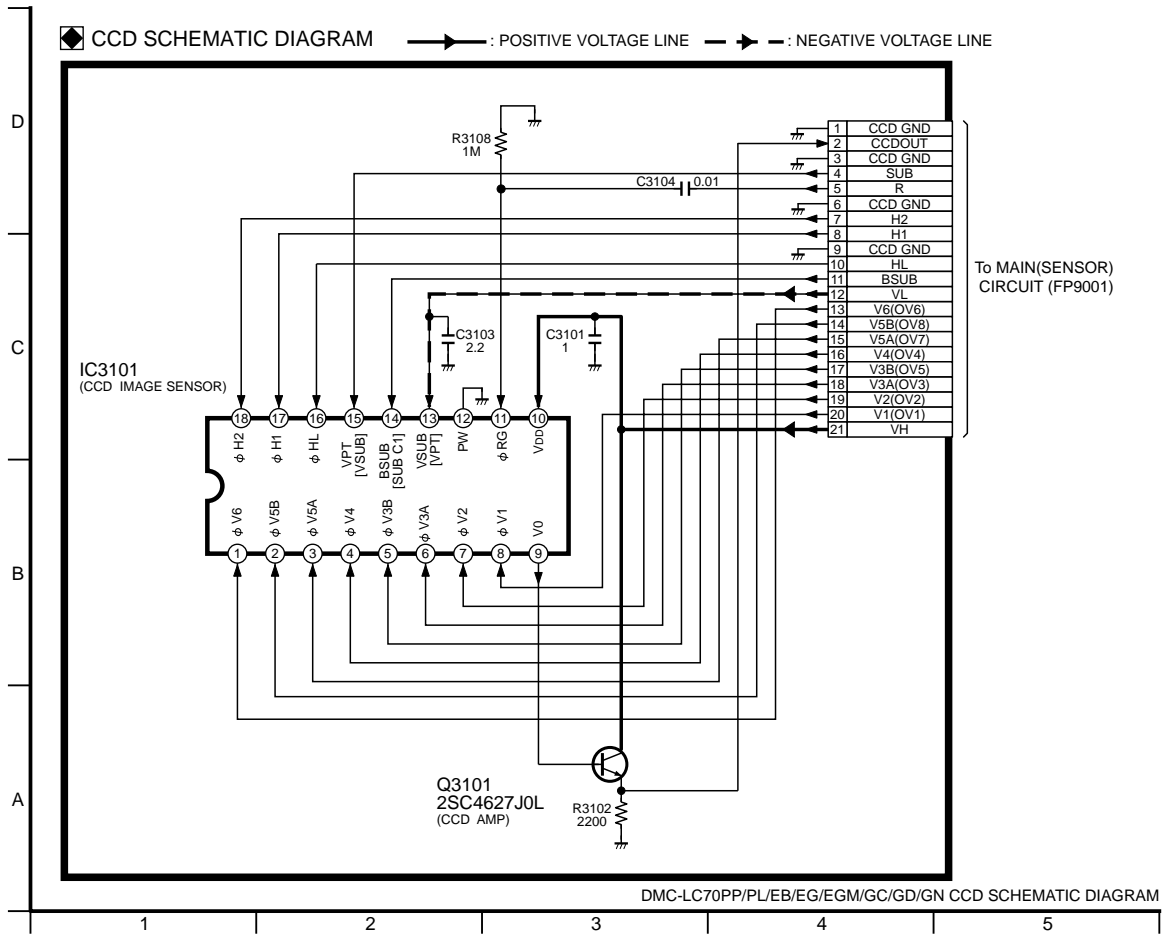

12.6. TOP OPERATION SCHEMATIC DIAGRAM

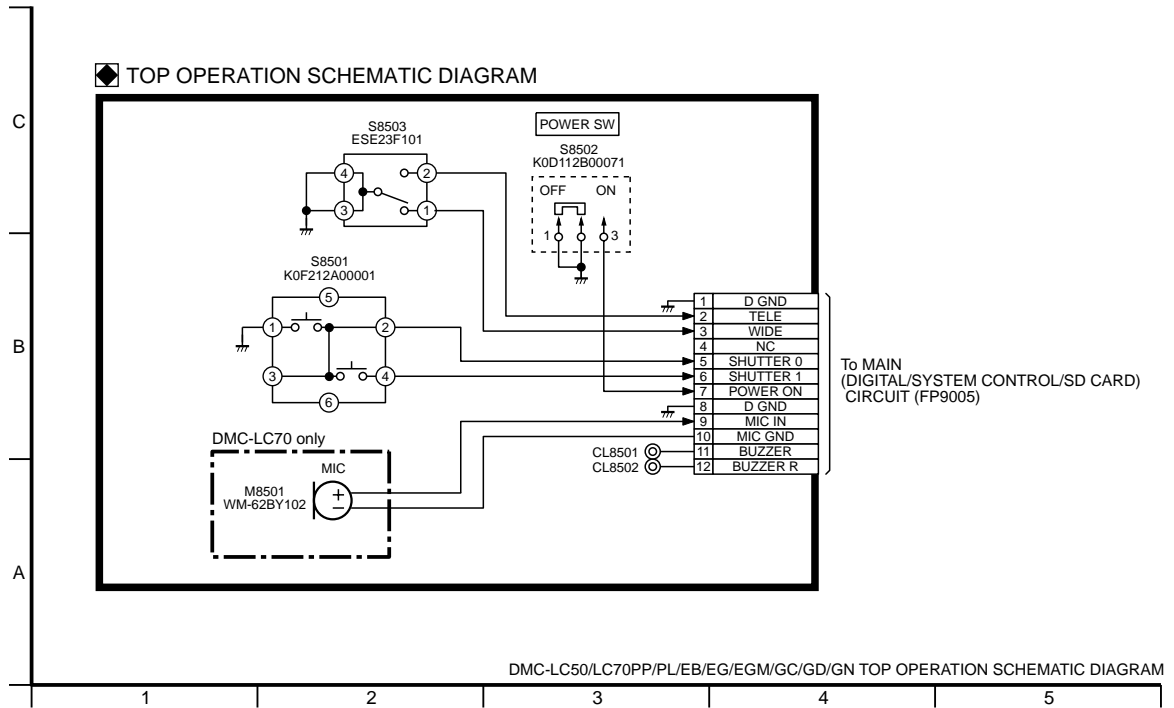



12.7. REAR OPERATION SCHEMATIC DIAGRAM

12.

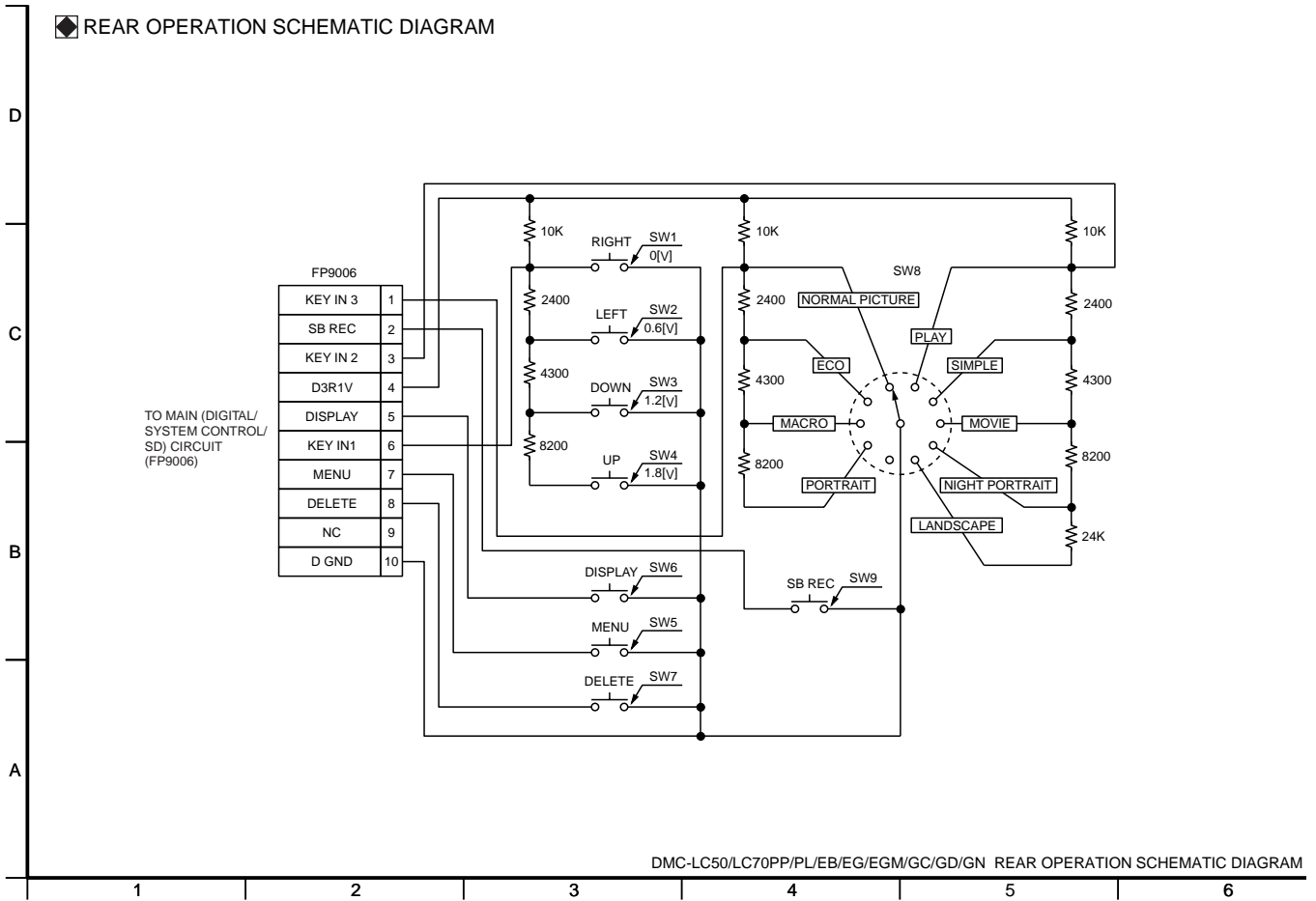

E

D

C

B

A



12.8. LENS FLEX SCHEMATIC DIAGRAM

