

# Service Manual

## DVD Recorder

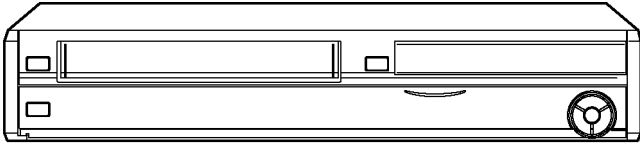

Model No. **DMR-EX98VEB**  
**DMR-EX98VEG**  
**DMR-EX98VEC**

**Notes: These model's RAM/Digital P.C.B. Module are - RFKNEX98VEB (EB)  
 - RFKNEX98VEG (EG)  
 - RFKNEX98VEC (EC).**

Vol. 1

Colours

(K).....Black Type

(S).....Silver Type

When replacing Dig. Interface P.C.B. or EEPROM, "UNFORMAT" indication is displayed and HDD must be formatted.

When replacing with HDD, it is necessary to update the firmware.

Please prepare the update disc.  
 (After that, FORMAT is necessary)

After that, programme in the HDD will be lost.  
 In detail, please refer to each content in this service manual.

### Caution:

Pairing of RAM Drive and Digital P.C.B. as "RAM/Digital P.C.B. Module" have to be replaced together. If the either RAM drive or Digital P.C.B. is changed, RAM Drive unit has to be re-aligned. Because the alignment data for RAM Drive Unit is stored in Digital P.C.B..

Manufactured under license from Dolby Laboratories. Dolby and the double-D symbol are trademarks of Dolby Laboratories.

"DTS" is a registered trademark of DTS, Inc. and "DTS 2.0+Digital Out" is a trademark of DTS, Inc.

This product incorporates copyright protection technology that is protected by U.S. patents and other intellectual property rights. Use of this copyright protection technology must be authorized by Macrovision, and is intended for home and other limited viewing uses only unless otherwise authorized by Macrovision. Reverse engineering or disassembly is prohibited.

- SDHC logo is a trademark.
- Portions of this product are protected under copyright law and are provided under license by ARIS/SOLANA/4C.

Official DivX® Certified product.  
 Plays all versions of DivX® video (including DivX®6) with standard playback of DivX® media files.  
 DivX, DivX Certified, and associated logos are trademarks of DivX, Inc. and are used under license.

HDMI, the HDMI logo and High-Definition Multimedia Interface are trademarks or registered trademarks of HDMI Licensing LLC.

HDAVI Control™ is a trademark of Matsushita Electric Industrial Co., Ltd.

# Panasonic®

© 2008 Matsushita Electric Industrial Co., Ltd. All rights reserved. Unauthorized copying and distribution is a violation of law.

## ⚠ WARNING

This service information is designed for experienced repair technicians only and is not designed for use by the general public. It does not contain warnings or cautions to advise non-technical individuals of potential dangers in attempting to service a product. Products powered by electricity should be serviced or repaired only by experienced professional technicians. Any attempt to service or repair the product or products dealt with in this service information by anyone else could result in serious injury or death.

# CONTENTS

	Page		Page
<b>1 Safety Precaution</b> .....	4	11.3. Analog Video (1/2) Block Diagram .....	63
1.1. General guidelines .....	4	11.4. Analog Video (2/2) Block Diagram .....	64
<b>2 Warning</b> .....	5	11.5. Analog Audio Block Diagram .....	65
2.1. Prevention of Electrostatic Discharge (ESD) to Electrostatic Sensitive (ES) Devices .....	5	11.6. D-IF/Timer Block Diagram .....	67
2.2. Precaution of Laser Diode .....	6	11.7. System Control & Servo Block Diagram .....	68
2.3. Service caution based on legal restrictions .....	7	11.8. HDMI Block Diagram .....	69
<b>3 Service Navigation</b> .....	8	<b>12 Schematic Diagram</b> .....	71
3.1. Service Information .....	8	12.1. Interconnection Schematic Diagram .....	71
3.2. Caution for DivX .....	9	12.2. Power Supply Section (Dig. Interface P.C.B. (1/2)) Schematic Diagram (P) .....	73
<b>4 Specifications</b> .....	10	12.3. Digital I/F (1/4) Section (Dig. Interface P.C.B. (2/2)) Schematic Diagram (IF) .....	75
<b>5 Location of Controls and Components</b> .....	13	12.4. Digital I/F (2/4) Section (Dig. Interface P.C.B. (2/2)) Schematic Diagram (IF) .....	76
5.1. Each Buttons .....	13	12.5. Digital I/F (3/4) Section (Dig. Interface P.C.B. (2/2)) Schematic Diagram (IF) .....	77
<b>6 Operation Instructions</b> .....	15	12.6. Digital I/F (4/4) Section (Dig. Interface P.C.B. (2/2)) Schematic Diagram (IF) .....	78
6.1. (DVD) Taking out the Disc from RAM-Drive Unit when the Disc cannot be ejected by OPEN/CLOSE button .....	15	12.7. Video Section (Main P.C.B. (1/5)) Schematic Diagram (V) .....	80
6.2. (VHS) Removing Cassette Tape manually .....	17	12.8. VHS Audio Section (Main P.C.B. (2/5)) Schematic Diagram (A) .....	81
<b>7 Service Mode</b> .....	19	12.9. Syscon/Servo/Timer (1/4) Section (Main P.C.B. (3/5)) Schematic Diagram (S) .....	83
7.1. (DVD) Self-Diagnosis and Special Mode Setting .....	19	12.10. Syscon/Servo/Timer (2/4) Section (Main P.C.B. (3/5)) Schematic Diagram (S) .....	84
7.2. (VHS) Self-Diagnosis and Special Mode Setting .....	33	12.11. Syscon/Servo/Timer (3/4) Section (Main P.C.B. (3/5)) Schematic Diagram (S) .....	85
<b>8 Service Fixture &amp; Tools</b> .....	37	12.12. Syscon/Servo/Timer (4/4) Section (Main P.C.B. (3/5)) Schematic Diagram (S) .....	86
<b>9 Assembling and Disassembling Instructions</b> .....	38	12.13. I/O Section (1/4) (Main P.C.B. (4/5)) Schematic Diagram (AV) .....	87
9.1. Disassembly Flow Chart .....	38	12.14. I/O Section (2/4) (Main P.C.B. (4/5)) Schematic Diagram (AV) .....	88
9.2. P.C.B. Positions .....	39	12.15. I/O Section (3/4) (Main P.C.B. (4/5)) Schematic Diagram (AV) .....	89
9.3. Caution with inserting cassette tape when disassembling the unit .....	40	12.16. I/O Section (4/4) (Main P.C.B. (4/5)) Schematic Diagram (AV) .....	90
9.4. Top Case .....	41	12.17. Tuner Section (Main P.C.B. (5/5)) Schematic Diagram (TU) .....	92
9.5. Front Panel .....	41	12.18. HDMI Schematic Diagram .....	94
9.6. Front Jack P.C.B., FL Drive P.C.B. ....	42	12.19. FL Drive Schematic Diagram .....	95
9.7. VHS Mechanism Unit .....	44	12.20. DV/SD/USB Schematic Diagram .....	97
9.8. RAM/Digital P.C.B. Module .....	45	12.21. Front Jack Schematic Diagram .....	98
9.9. DV/SD/USB P.C.B. ....	46	12.22. ATAPI Schematic Diagram .....	99
9.10. Rear Panel, Fan Motor .....	47	<b>13 Printed Circuit Board</b> .....	<b>101</b>
9.11. HDMI P.C.B. ....	47		
9.12. Dig. Interface P.C.B. ....	48		
9.13. HDD .....	48		
9.14. Backend P.C.B. ....	49		
9.15. Main P.C.B. ....	49		
<b>10 Measurements and Adjustments</b> .....	<b>50</b>		
10.1. Service Positions .....	50		
10.2. Caution for Replacing Parts .....	54		
10.3. (DVD) Standard Inspection Specifications after Making Repairs .....	59		
<b>11 Block Diagram</b> .....	<b>61</b>		
11.1. Power Supply Block Diagram .....	61		
11.2. Main P.C.B. Regulator Block Diagram .....	62		

13.1. Dig. Interface P.C.B. ....	101	<b>14 Appendix for Schematic Diagram</b> .....	<b>117</b>
13.2. Main P.C.B. ....	106	14.1. Voltage and Waveform Chart .....	117
13.3. HDMI P.C.B. ....	111	14.2. Abbreviations .....	126
13.4. FL Drive P.C.B. ....	112	<b>15 Parts and Exploded Views</b> .....	<b>132</b>
13.5. DV/SD/USB P.C.B. ....	113	15.1. Exploded Views .....	132
13.6. ATAPI P.C.B. ....	114	15.2. Replacement Parts List .....	136
13.7. Front Jack P.C.B. ....	115		

# 1 Safety Precaution

## 1.1. General guidelines

1. When servicing, observe the original lead dress. If a short circuit is found, replace all parts which have been overheated or damaged by the short circuit.
2. After servicing, see to it that all the protective devices such as insulation barriers, insulation papers shields are properly installed.
3. After servicing, make the following leakage current checks to prevent the customer from being exposed to shock hazards.

### 1.1.1. Leakage current cold check

1. Unplug the AC cord and connect a jumper between the two prongs on the plug.
2. Measure the resistance value, with an ohmmeter, between the jumpered AC plug and each exposed metallic cabinet part on the equipment such as screwheads, connectors, control shafts, etc. When the exposed metallic part has a return path to the chassis, the reading should be between  $1M\Omega$  and  $5.2M\Omega$ .

When the exposed metal does not have a return path to the chassis, the reading must be  $\infty$ .

### 1.1.2. Leakage current hot check (See Figure 1 .)

1. Plug the AC cord directly into the AC outlet. Do not use an isolation transformer for this check.
2. Connect a  $1.5k\Omega$ , 10 watts resistor, in parallel with a  $0.15\mu F$  capacitors, between each exposed metallic part on the set and a good earth ground such as a water pipe, as shown in Figure 1.
3. Use an AC voltmeter, with 1000 ohms/volt or more sensitivity, to measure the potential across the resistor.
4. Check each exposed metallic part, and measure the voltage at each point.
5. Reverse the AC plug in the AC outlet and repeat each of the above measurements.
6. The potential at any point should not exceed 0.75 volts RMS. A leakage current tester (Simpson Model 229 or equivalent) may be used to make the hot checks, leakage current must not exceed 1/2 milliampere. In case a measurement is outside of the limits specified, there is a possibility of a shock hazard, and the equipment should be repaired and rechecked before it is returned to the customer.

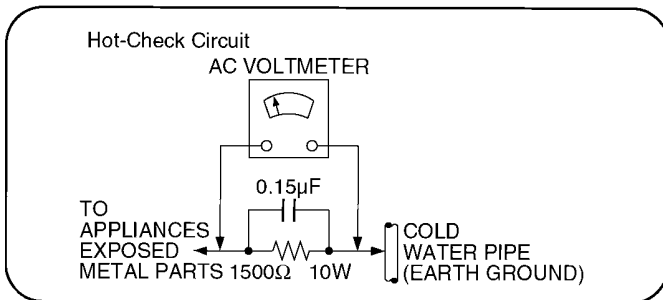

Figure 1

## 2 Warning

### 2.1. Prevention of Electrostatic Discharge (ESD) to Electrostatic Sensitive (ES) Devices

Some semiconductor (solid state) devices can be damaged easily by static electricity. Such components commonly are called Electrostatic Sensitive (ES) Devices. Examples of typical ES devices are integrated circuits and some field-effect transistor-and semiconductor "chip" components. The following techniques should be used to help reduce the incidence of component damage caused by electrostatic discharge (ESD).

1. Immediately before handling any semiconductor component or semiconductor-equipped assembly, drain off any ESD on your body by touching a known earth ground. Alternatively, obtain and wear a commercially available discharging ESD wrist strap, which should be removed for potential shock reasons prior to applying power to the unit under test.
2. After removing an electrical assembly equipped with ES devices, place the assembly on a conductive surface such as aluminum foil, to prevent electrostatic charge buildup or exposure of the assembly.
3. Use only a grounded-tip soldering iron to solder or unsolder ES devices.
4. Use only an anti-static solder removal device. Some solder removal devices not classified as "anti-static (ESD protected)" can generate electrical charge sufficient to damage ES devices.
5. Do not use freon-propelled chemicals. These can generate electrical charges sufficient to damage ES devices.
6. Do not remove a replacement ES device from its protective package until immediately before you are ready to install it. (Most replacement ES devices are packaged with leads electrically shorted together by conductive foam, aluminum foil or comparable conductive material).
7. Immediately before removing the protective material from the leads of a replacement ES device, touch the protective material to the chassis or circuit assembly into which the device will be installed.

#### Caution

Be sure no power is applied to the chassis or circuit, and observe all other safety precautions.

8. Minimize bodily motions when handling unpackaged replacement ES devices. (Otherwise harmless motion such as the brushing together of your clothes fabric or the lifting of your foot from a carpeted floor can generate static electricity sufficient to damage an ES device).

#### IMPORTANT SAFETY NOTICE

There are special components used in this equipment which are important for safety. These parts are marked by  $\triangle$  in the schematic diagrams, Exploded Views and replacement parts list. It is essential that these critical parts should be replaced with manufacturer's specified parts to prevent shock, fire, or other hazards. Do not modify the original design without permission of manufacturer.

## 2.2. Precaution of Laser Diode

### CAUTION:

This product utilizes a laser diode with the unit turned "on", invisible laser radiation is emitted from the pickup lens.

Wave length: 662 nm (DVDs)/780 nm (CDs)

Maximum output radiation power from pickup: 100  $\mu$  W/VDE

Laser radiation from the pickup lens is safety level, but be sure the followings:

1. Do not disassemble the optical pickup unit, since radiation from exposed laser diode is dangerous.
2. Do not adjust the variable resistor on the pickup unit. It was already adjusted.
3. Do not look at the focus lens using optical instruments.
4. Recommend not to look at pickup lens for a long time.

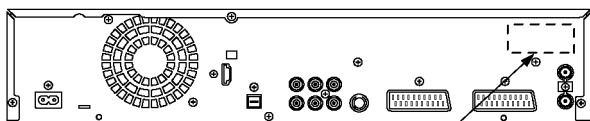

LUOKAN 1 LASERLAITE  
KLASS 1 LASER APPARAT



### ACHTUNG:

Dieses Produkt enthält eine Laserdiode.

Im eingeschalteten Zustand wird unsichtbare Laserstrahlung von der Lasereinheit abgestrahlt.

Wellenlänge: 662 nm (DVDs)/780 nm (CDs)

Maximale Strahlungsleistung der Lasereinheit: 100  $\mu$  W/VDE

Die Strahlung der Lasereinheit ist ungefährlich, wenn folgende Punkte beachtet werden:

1. Die Lasereinheit nicht zerlegen, da die Strahlung an der freigelegten Laserdiode gefährlich ist.
2. Den werkseitig justierten Einstellregler der Lasereinheit nicht verstellen.
3. Nicht mit optischen Instrumenten in die Fokussierlinse blicken.
4. Nicht über längere Zeit in die Fokussierlinse blicken.

<b>DANGER – VISIBLE AND INVISIBLE LASER RADIATION WHEN OPEN. AVOID DIRECT EXPOSURE TO BEAM.</b> FDA 21 CFR/Class IIb	
<b>CAUTION</b> – CLASS 3B VISIBLE AND INVISIBLE LASER RADIATION WHEN OPEN AVOID EXPOSURE TO THE BEAM. IEC60825-1 +2/Class 3B	
<b>ATTENTION</b> – RAYONNEMENT LASER VISIBLE ET INVISIBLE, CLASSE 3B, EN CAS D'OUVERTURE, ÉVITER UNE EXPOSITION AU FAISCEAU.	
<b>FORSIGTIG</b> – SYNLIG OG USYNLIG LASERSTRÅLING KLASSE 3B, NÅR LÅGET ER ÅBENT. UNDGÅ AT BLIVE UDSAT FOR STRÅLEN.	
<b>VARO</b> – AVATTRESSA OLEI ALTIINA LUOKAN 3B NÄKYNÄÄ JA NÄKYMÄTÖNTÄ LASERSÄTELTÄ. VARO ALTISTUMISTA SÄTEELLE.	
<b>WARNING</b> – KLASS 3B SYNLIG OCH OSYNLIG LASERSTRÅLNING NÅR DENNA DEL ÄR ÖPPNAD. UNDVIK EXPONERING FÖR STRÅLEN.	
<b>VORSICHT</b> – SICHTBARE UND UNSICHTBARE LASERSTRALUNG KLASSE 3B, WENN ABDECKUNG GEÖFFNET. NICHT DEM STRAHL AUSSETZEN.	
<b>注意</b> – 打开时有可见及不可见激光辐射。避免光束照射。	
<b>注意</b> – ここを開くと可視及び不可視レーザー光が出ます。ビームを見たり、触れたりしないでください。 VQL1J70	

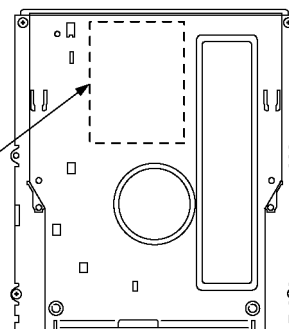

### CAUTION!

THIS PRODUCT UTILIZES A LASER.

USE OF CONTROLS OR ADJUSTMENTS OR PERFORMANCE OF PROCEDURES OTHER THAN THOSE SPECIFIED HEREIN MAY RESULT IN HAZARDOUS RADIATION EXPOSURE.

## 2.3. Service caution based on legal restrictions

### 2.3.1. General description about Lead Free Solder (PbF)

The lead free solder has been used in the mounting process of all electrical components on the printed circuit boards used for this equipment in considering the globally environmental conservation.

The normal solder is the alloy of tin (Sn) and lead (Pb). On the other hand, the lead free solder is the alloy mainly consists of tin (Sn), silver (Ag) and Copper (Cu), and the melting point of the lead free solder is higher approx.30 degrees C (86°F) more than that of the normal solder.

#### Definition of PCB Lead Free Solder being used

The letter of "PbF" is printed either foil side or components side on the PCB using the lead free solder. (See right figure)	<b>PbF</b>

#### Service caution for repair work using Lead Free Solder (PbF)

- The lead free solder has to be used when repairing the equipment for which the lead free solder is used.  
(Definition: The letter of "PbF" is printed on the PCB using the lead free solder.)
- To put lead free solder, it should be well molten and mixed with the original lead free solder.
- Remove the remaining lead free solder on the PCB cleanly for soldering of the new IC.
- Since the melting point of the lead free solder is higher than that of the normal lead solder, it takes the longer time to melt the lead free solder.
- Use the soldering iron (more than 70W) equipped with the temperature control after setting the temperature at 350±30 degrees C (662±86°F).

#### Recommended Lead Free Solder (Service Parts Route.)

- The following 3 types of lead free solder are available through the service parts route.  
RFKZ03D01K------(0.3mm 100g Reel)  
RFKZ06D01K------(0.6mm 100g Reel)  
RFKZ10D01K------(1.0mm 100g Reel)

#### Note

- \* Ingredient: tin (Sn), 96.5%, silver (Ag) 3.0%, Copper (Cu) 0.5%, Cobalt (Co) / Germanium (Ge) 0.1 to 0.3%

## 3 Service Navigation

### 3.1. Service Information

This service manual contains technical information which will allow service personnel's to understand and service this model.

Please place orders using the parts list and not the drawing reference numbers.

If the circuit is changed or modified, this information will be followed by supplement service manual to be filed with original service manual.

1) This service manual does not contain the following information, because of the impossibility of servicing at component level.

- \* Schematic Diagram, Block Diagram and P.C.B. layout for RAM/Digital P.C.B. Module and Backend P.C.B..
- \* Parts List of individual parts for Digital P.C.B and Back End P.C.B..
- \* Exploded View and Parts List of individual parts for RAM/Digital P.C.B. Module and Backend P.C.B..

2) The following category are recycle module part. Please send them to Central Repair Center.

- \* RAM/Digital P.C.B. Module  
(EX98VEB: RFKNEX98VEB, EX98VEG: RFKNEX98VEG, EX98VEC: RFKNEX98VEC)
- \* Backend P.C.B.  
(EX98VEB: RFKB77123A, EX98VEG: RFKB77123B, EX98VEC: RFKB77123C)

3) If the circuit is changed or modified, this information will be followed by supplement service manual to be filed with original service manual.

4) Adjustment procedures, Disassembly Procedures and Assembly Procedures for VCR Mechanism Chassis are separate volume from this service manual. Please refer to the service manual for R4 Mechanism Chassis for EURO model (MAD0403002C2).

### 3.2. Caution for DivX

Please will always pass the customer "Warning for Customers Who Use the DivX Video-on-Demand content." with the product and get it when you unavoidably exchange EEPROM or P.C.B. including EEPROM (When the product is exchanged, it is the same.).

You must use print attached to service part (EEPROM or P.C.B. including EEPROM) or must use copy of print below as "Warning for Customers who use the DivX Video-on-Demand content."

Information needed without fail for the customer for whom it is used continuing DivX Video-on-Demand Service to "Manual for the customer" is recorded.

Appendix:

- \* Parts that memorize user's information are only EEPROM (RFKFXXXXXX).
- \* The registration of Registration Code is possible for half a year up to 6 recorders up to 10 recorders a year.  
Replacement of EEPROM or P.C.B. including EEPROM spends one of this.

Registration Code is memorized in EEPROM.

Model without VHS: Main P.C.B.

Model with VHS: Dig. Interface P.C.B. (Power & DVD I/F P.C.B.)

If exchange above P.C.B. or EEPROM, new registration Code differ from previous Registration Code will be generated.

In this case if your customer uses DivX Video-on-Demand service, he/she will no longer be able to play any content that he/she purchased under that same registration code.

Therefore your customer will need to obtain and register the new registration code.

\*Copy this page and cut on the dotted line and give the lower half to your customer.

---

#### Warning for Customers who use the DivX Video-on-Demand content.

1. The registration code has been changed for the repair of the product or the product exchange.
2. Obtain and register a new registration code, otherwise you will no longer be able to play DivX Video-on-Demand content.
3. Follow the procedure on the DivX Video-on-Demand web site to register at  
<http://vod.divx.com/>

\* If you do not use the DivX Video-on-Demand content, please ignore this warning.

## 4 Specifications

Power supply:	AC 220 - 240V 50Hz					
Power consumption:	Approx. 40W					
Power consumption in standby mode:	Approx. 2W (Power save mode) Approx. 22W (Quick start mode)					
Operating temperature:	5°C - 40°C					
Operating humidity range:	10% - 80% RH (no condensation)					
Television system						
DMR-EX98VEB						
Tuner System:	DVB-T					
Channel Coverage:	UK					
UHF:	21 - 68					
DMR-EX98VEC						
Tuner System:	PAL-BGH, SECAM-BG	SECAM-L, L'	DVB-T			
Channel Coverage:	CCIR	France	France	Italy	Spain/Swiss	
VHF:	E2-E12, A-H2 (Italy)	2-10	5-10	D-H2	5-12	
UHF:	21-69	21-69	21-69	21-69	21-69	
CATV:	S01-S05 (S1-S3) S1-S20 (M1-U10) S21-S41	B-Q (100.5- 299.25 MHz) S21-S41 (299.25- 467.25 MHz)	----	----	----	
DMR-EX98VEG						
Tuner System:	PAL-BGH, SECAM-BG		DVB-T			
Channel Coverage:	CCIR		Germany			
VHF:	E2-E12, A-H2 (Italy)		5-12			
UHF:	21-69		21-69			
CATV:	S01-S05 (S1-S3) S1-S20 (M1-U10) S21-S41		----			
RF Converter output:	Not provided					
Video						
Video system:	PAL colour signal, 625 lines, 50 fields NTSC colour signal, 525 lines, 60 fields					
Recording system:	MPEG2 (Hybrid VBR)					
Video in (PAL/NTSC):	AV1/AV2 (21 pin), AV3 (pin jack) 1 Vp-p 75 ohm, termination					
S-Video in (PAL/NTSC):	AV2 (21 pin), AV3 (S terminal) 1 Vp-p 75 ohm, termination					
RGB in (PAL):	AV2 (21 pin) 0.7 Vp-p (PAL) 75 ohm, termination					
Video out (PAL/NTSC):	AV1/AV2 (21 pin), Video out (pin jack) 1 Vp-p 75 ohm, termination					
S-Video out (PAL/NTSC):	AV1 (21 pin), S-Video out (S terminal) 1 Vp-p 75 ohm, termination					
RGB out (PAL/NTSC):	AV1 (21 pin) 0.7Vp-p (PAL) 75 ohm, termination					
Component video output (NTSC 480p/480i) (PAL 576p/576i)	Y: 1.0 Vp-p 75 ohm, termination PB: 0.7 Vp-p 75 ohm, termination PR: 0.7 Vp-p 75 ohm, termination					
Audio						
Recording system:	Dolby Digital 2ch, Linear PCM (XP mode)					
Audio in:	AV1/AV2 (21 pin), AV3 (pin jack)					
Input level:	Standard: 0.5 Vrms, Full scale: 2.0 Vrms at 1 kHz					
Input impedance:	More than 10k ohm					
Audio out:	AV1/AV2 (21 pin), Audio Out (pin jack)					
Output level:	Standard: 0.5 Vrms, Full scale: 2.0 Vrms at 1 kHz					
Output impedance:	Less than 1k ohm					
Digital audio out:	Optical terminal (PCM, Dolby Digital, DTS, MPEG)					
HDMI Output:	19 pin type A: 1 pc					
Internal HDD Capacity:	250GB					
DV Input:	IEEE 1394 Standard, 4 pin: 1 pc					
USB Port:	Type A: 1 pc					
SD Card Slot	1 pc					
Recording time						
Approx.						
Recording mode	DVD-RAM		DVD-R/ DVD-RW/ +R/+RW	DVD-R DL	+R DL	Hard Disk
	4.7GB	9.4GB (Double sided)	8.5GB	8.5GB	250GB	
XP	1h.	2h.	1h.	1h. 45m.	1h. 45m.	55h.
SP	2h.	4h.	2h.	3h. 35m.	3h. 35m.	110h.
LP	4h.	8h.	4h.	7h. 10m.	7h. 10m.	221h.
EP (6h)	6h.	12h.	6h.	10h. 45m.	----	331h.
EP (8h)	8h.	16h.	8h.	14h. 20m.	----	441h.
Approximate copying times (Max. speed)						
On Hard Disk		5x speed DVD-RAM		12x speed DVD-R (*1)		
Recording mode	Recorded program	Required time	speed	Required time	speed	
XP	1h.	12m.	5x	5m. 46s.	10x	
SP	1h.	6m.	10x	2m. 30s.	24x	
LP	1h.	3m.	20x	1m. 21s.	44x	
EP (6h)	1h.	2m.	30x	58s.	62x	
EP (8h)	1h.	1m. 30s.	40x	48s.	75x	
		4x speed DVD-R DL (Dual layer) (*2)		4x speed DVD-RW (*3)		
Required time	speed	Required time	speed	Required time	speed	
15m.	4x	15m.	4x	8m. 20s.	7x	
7m. 30s.	8x	7m. 30s.	8x	3m. 45s.	16x	
3m. 45s.	16x	3m. 45s.	16x	1m. 53s.	32x	
2m. 30s.	24x	2m. 30s.	24x	----	----	
1m. 53s.	32x	1m. 57s.	31x	----	----	
		4x speed +R DL (Double layer) (*2)		4x speed +RW		
Required time	speed	Required time	speed	Required time	speed	
15m.	4x	15m.	4x	----	----	
7m. 30s.	8x	7m. 30s.	8x	----	----	
3m. 45s.	16x	3m. 45s.	16x	----	----	
----	----	----	----	----	----	

### NOTE

The above rated value indicates the fastest time and speed required for copying one-hour title from HDD to each disc in the above list supporting High-Speed copying. The amount of time and speed may vary depending on the conditions such as the area on where information is written or unique feature on the disc.

- \*1: In this unit, copying with 16X Speed DVD-R disc will be performed at the same speed as 12X Speed DVD-R disc takes.
- \*2: In this unit, copying with 8X Speed discs, DVD-R DL and +R DL, will be performed at the same speed as 4X Speed discs, DVD-R DL and +R DL, take.
- \*3: In this unit, copying with 6X Speed DVD-RW disc will be performed at the same speed as 4X Speed DVD-RW disc takes.
- \*4: In this unit, copying with 16X Speed +R disc will be performed at the same speed as 8X Speed +R disc takes.

Recordable discs		Completion method	
DVD-RAM:	2X SPEED (Ver. 2.0) 2-3X SPEED (Ver. 2.1) 2-5X SPEED (Ver. 2.2)	*7: Total number of recognizable file including MP3, JPEG, DivX and other type of files is 4000.	
DVD-R (SL):	1X SPEED (Ver. 2.0) 1-4X SPEED (Ver. 2.0) 1-8X SPEED (Ver. 2.0) 1-16X SPEED (Ver. 2.1)	DVD (DivX), CD (DivX)	Plays all versions of DivX video (including DivX 6) with standard playback of DivX media files. Certified to the DivX Home Theater Profile.
DVD-R (DL):	2-4X SPEED (Ver. 3.0) 2-8X SPEED (Ver. 3.0)	DVD (DivX), CD (DivX) Common Items	Maximum number of folders: 300 Recognizable folders per disc on this unit (including the root folder) Maximum number of DivX files: 200 Recognizable DivX files per disc on this unit (*7)
DVD-RW:	1X SPEED (Ver. 1.1) 1-2X SPEED (Ver. 1.1) 2-4X SPEED (Ver. 1.2) 2-6X SPEED (Ver. 1.2)	DVD (MP3), CD (MP3)	Format: ISO9660 level 1 or 2 (except for extended formats), Joliet Compatible compression rate: 32kbps - 320kbps Compatible sampling rate: 16kHz, 22.05kHz, 24kHz, 32kHz, 44.1kHz, 48kHz
DVD+R (SL):	2.4X SPEED (Ver. 1.0) 2.4-4X SPEED (Ver. 1.1) 2.4-8X SPEED (Ver. 1.2) 2.4-16X SPEED (Ver. 1.3)	DVD (JPEG), CD (JPEG)	Format: ISO9660 level 1 or 2 (except for extended formats), Joliet Compatible pixels: Between 34 x 34 and 6144 x 4096 pixels Sub Sampling 4:2:2 or 4:2:0 This unit is not compatible with MOTION JPEG.
+R (DL):	2.4X SPEED (Ver. 1.0) 2.4-8X SPEED (Ver. 1.1)	DVD (MP3), CD (MP3), DVD (JPEG), CD (JPEG) Common Items	Maximum number of folders: 300 Recognizable folders per disc on this unit (including the root folder) Maximum number of MP3 files: 3000 Recognizable MP3 files per disc on this unit (*7) Maximum number of JPEG files: 3000 Recognizable JPEG files per disc on this unit (*7) This unit is compatible with multi-session. This unit is not compatible with packet writing.
+RW:	2.4X SPEED (Ver. 1.1) 2.4-4X SPEED (Ver. 1.2)	SVCD	Format: IEC62107 This unit is not compatible with "Chaoji Video CD" available on the market including CVD, DVCD and that do not conform to IEC62107.
Optical pick-up	System with 1 lens, 2 integration units (662 nm wavelength for DVDs, 780 nm wavelength for CDs)	SD Card	SD Card Slot: SD Memory Card slot: 1 pc Compatible media: SD Memory Card (*8), SDHC Memory Card, Multi Media Card Format: FAT12, FAT16 (*9) (In case of SD Memory Card, Multi Media Card), FAT32 (*9) (In case of SDHC Memory Card) Still picture (JPEG) Format: JPEG conforming DCF (Design rule for Camera File system) Compatible pixels: Between 34 x 34 and 6144 x 4096 pixels Sub Sampling 4:2:2 or 4:2:0 Thawing time: Approx. 1.9 sec (6 M pixels, JPEG) This unit is not compatible with MOTION JPEG. Video (SD-Video) (*10) Codec: MPEG 2 (SD-Video Entertainment Video Profile) File Format: SD-Video format conforming *8: Includes miniSD cards. (A miniSD adaptor needs to be inserted.) Includes microSD cards. (A microSD adaptor needs to be inserted.) *9: Long file name is unsupported *10: Video Recording conversion and transfer is possible from card to HDD or DVD-RAM disc. After Video Recording conversion and transfer to HDD or DVD-RAM disc, the playback is possible.
LASER specification	Class 1 LASER Product (Pickup) Wave length: CD 780 nm wave length, DVD 662 nm wave length Laser power: No hazardous radiation is emitted with the safety protection		
Regional Code	#2		
Playable discs	DVD-RAM : DVD Video Recording format DVD-R : DVD-Video format, MP3 (*5), JPEG (*5), DivX (*5) DVD-R DL (Dual Layer) : DVD-Video format, MP3 (*5), JPEG (*5), DivX (*5) DVD-RW : DVD-Video format, DVD Video Recording format +R, +R DL (Double Layer), +RW DVD-VIDEO CD-Audio (CD-DA), Video CD, SVCD CD-R/CD-RW : CD-DA (*5), Video CD (*5), SVCD (*5), MP3 (*5), JPEG (*5), DivX (*5) *5: Finalizing is necessary for compatible playback.		
Recording System	DVD-RAM : DVD Video Recording format DVD-R : DVD-Video format DVD-R DL (Dual Layer): DVD-Video format DVD-RW : DVD-Video format +R, +R DL (Double Layer), +RW		
HDMI:	HDMI™ (Ver. 1.3 with Deep Colour) (This unit supports "HDAVI Control 3" function.)		
Quick Start for Recording & EPG display: (Power Save: OFF)	1 Sec. Quick Start for Recording & EPG Display (*6) (When connecting to TV using 21-pin Scart, Component Video, Video or S- Video terminals) *6: From the power on, recording on DVD-RAM and HDD starts in about 1 second after the REC button is pressed. If the GUIDE button is pressed while the unit is off, the Electronic Program Guide (EPG) displays in less than 1 second. (Quick Start Mode)		

USB	<p>USB standard : USB 2.0 High Speed  Format : FAT16, FAT32</p> <p>DivX  Plays all versions of DivX video (including DivX 6) with standard playback of DivX media files.  Certified to the DivX Home Theater Profile.  Maximum number of folders:  300 Recognizable folders per USB on this unit (including the root folder)  Maximum number of DivX files:  200 Recognizable DivX files per USB on this unit (*11)</p> <p>MP3  Compatible compression rate: 32kbps - 320kbps  Compatible sampling rate: 16kHz, 22.05kHz, 24kHz, 32kHz, 44.1kHz, 48kHz  This unit is compatible with ID3 tags.</p> <p>Still picture (JPEG)  Format: JPEG  Compatible pixels: Between 34 x 34 and 6144 x 4096 pixels  Sub Sampling 4:2:2 or 4:2:0  This unit is not compatible with MOTION JPEG.</p> <p>JPEG, MP3 Common Items  Maximum number of folders:  300 Recognizable folders per USB on this unit (including the root folder)  Maximum number of MP3 files:  3000 Recognizable MP3 files per USB on this unit (*11)  Maximum number of JPEG files:  3000 Recognizable JPEG files per USB on this unit (*11)</p> <p>Video (SD-Video) (*12)  Codec: MPEG 2 (SD-Video Entertainment Video Profile)  File Format: SD-Video format conforming</p> <p>*11: Total number of recognizable file including MP3, JPEG, DivX and other type of files is 4000.  *12: Video Recording conversion and transfer is possible from UCB to HDD or DVD-RAM disc.  After Video Recording conversion and transfer to HDD or DVD-RAM disc, the playback is possible.</p>
VHS	
Recording format:	VHS Video Cassette System Standard with FM audio
Heads:	4 Helical scan Heads for Video 2 Helical scan Heads for FM audio 1 Fixed Head for Normal audio
Tape Speed/Recording Time: (with E-240 tape)	PAL: SP: 23.39 mm/s, 240 min. LP: 11.7 mm/s, 480 min. EP: 7.8 mm/s, 720 min. NTSC: SP: 33.35 mm/s, 168 min. EP: 11.12 mm/s, 505 min.
Dimensions:	430 mm (W) × 84 mm (H) × 341 mm (D) (excluding the projecting parts) 430 mm (W) × 84 mm (H) × 350 mm (D) (including the projecting parts)
Mass:	Approx. 6.3 kg

**Notes** : Mass and dimensions are approximate.  
Specifications are subject to change without notice.

## 5 Location of Controls and Components

### 5.1. Each Buttons

Followings are the Location of Controls and Components for DMR-EX98VEB as a sample.

For other model, refer to each Operation Instructions.

#### Remote Control

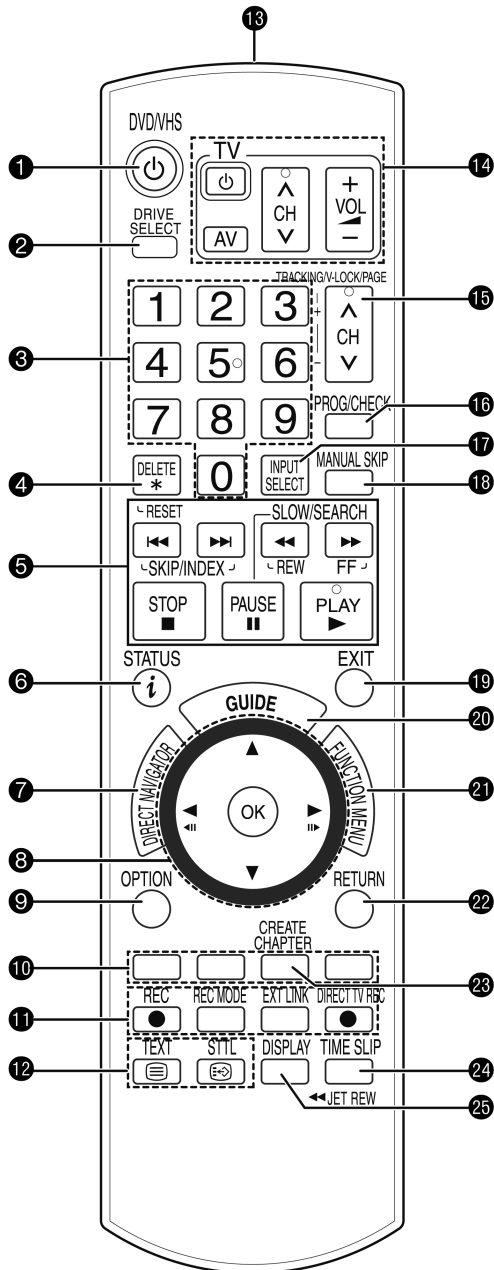

- 1 Turn the unit on or off
- 2 Select drive [HDD, DVD, SD or VHS]
- 3 Select channels and title numbers etc./ Enter numbers
- 4 To delete unwanted recorded titles, still pictures or music/Reset the tape counter
- 5 Basic operations for recording and play
- 6 Show the digital channel information/ Programme information within GUIDE Plus+ screen/ Show status messages
- 7 DIRECT NAVIGATOR
- 8 Selection/OK, Frame-by-frame
- 9 Show OPTION menu  
This menu is used when playing or editing titles and still pictures, etc.
- 10 Use Colour buttons according to on-screen instructions.  
– for switching the DIRECT NAVIGATOR screen  
– for switching Video/Playlists  
– for GUIDE Plus+ operations  
– disactivating timer programme  
– for selecting programme category  
– for editing profiles
- 11 Recording function  
[● REC]: Start recording  
[REC MODE]: Change recording mode  
[EXT LINK]: Linked timer recordings with external equipment  
[● DIRECT TV REC]: Direct TV recording
- 12 DVB function  
[TEXT (☺)]: Show Digital TEXT (MHEG) service  
[STTL (☺)]: Show subtitles
- 13 Transmission window
- 14 TV operations
- 15 Channel select/Change pages in the GUIDE Plus+ list/TRACKING/V-LOCK  
Show timer recording list
- 16 Input select (Tuner, AV1, AV2, AV3, DV)
- 17 Skip approx. 1 minute forward
- 19 Exit the menu screen
- 20 Show the GUIDE Plus+ screen
- 21 Show FUNCTION MENU window  
By using the FUNCTION MENU window you may access the main functions (Playback, Recording, etc.) quickly and easily.
- 22 Return to previous screen
- 23 Create chapters
- 24 Skip the specified time/Jet rewind button (JET REW)
- 25 Show menu for disc playback etc./ Change DVB multi audio

## The Unit's Display

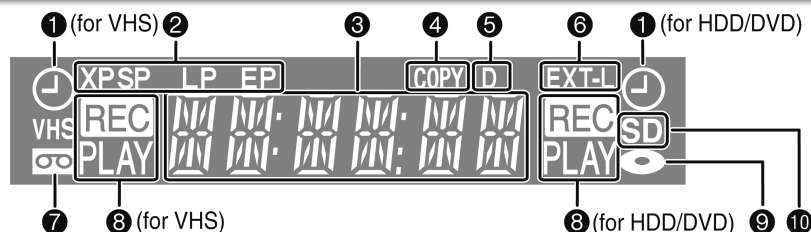

- |  |  |
|--|--|
| <p><b>1</b> Timer recording indicator (Ⓣ)<br/> <b>On:</b><br/>         When a timer recording programme is registered and a recordable disc or video cassette is inserted.<br/> <b>Flashes:</b><br/>         When the unit cannot record a timer recording programme (e.g., there is no disc or video cassette, etc.).</p> <p><b>2</b> Recording mode indicator</p> <p><b>3</b> Main display</p> <p><b>4</b> Copying indicator</p> | <p><b>5</b> Digital broadcast indicator<br/>         Lights when the unit is receiving digital broadcast or GUIDE Plus+ data.</p> <p><b>6</b> Linked timer recordings with external equipment indicator</p> <p><b>7</b> Tape indicator</p> <p><b>8</b> Operation status</p> <p><b>9</b> Disc indicator</p> <p><b>10</b> SD card slot indicator</p> |
|--|--|

## Main Unit

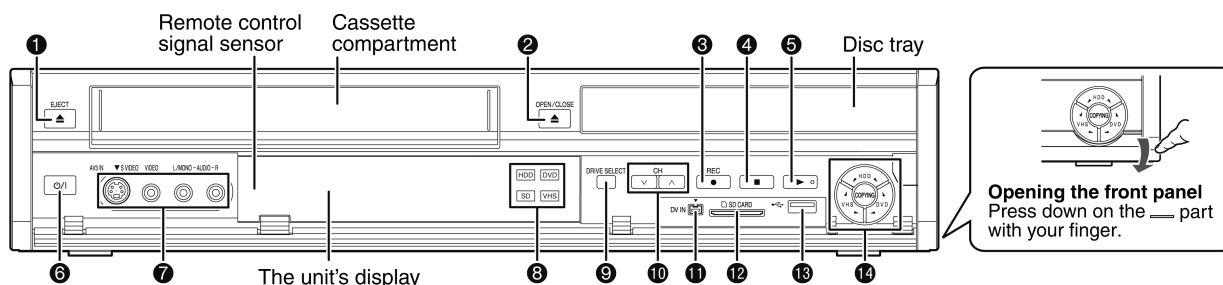

- |   |   |
|---|---|
| <p><b>1</b> Cassette eject button</p> <p><b>2</b> Disc tray open/close button</p> <p><b>3</b> Start recording button</p> <p><b>4</b> Stop button</p> <p><b>5</b> Play/X1.3 button</p> <p><b>6</b> <b>Standby/on switch</b> (Ⓡ/Ⓡ)<br/>         Press to switch the unit from on to standby mode or vice versa. In standby mode, the unit is still consuming a small amount of power.</p> <p><b>7</b> AV3 input terminals</p> | <p><b>8</b> HDD/DVD/SD/VHS drive indicator<br/>         • Lights when the HDD, DVD, SD or VHS drive is selected.</p> <p><b>9</b> DRIVE SELECT button<br/>         • Drive changes each time you press [DRIVE SELECT].</p> <p><b>10</b> Channel Select button</p> <p><b>11</b> DV IN terminal<br/>         (for a digital video camcorder)</p> <p><b>12</b> SD card slot</p> <p><b>13</b> USB port</p> <p><b>14</b> One Touch Copying operation button</p> |
|---|---|

## Rear Panel

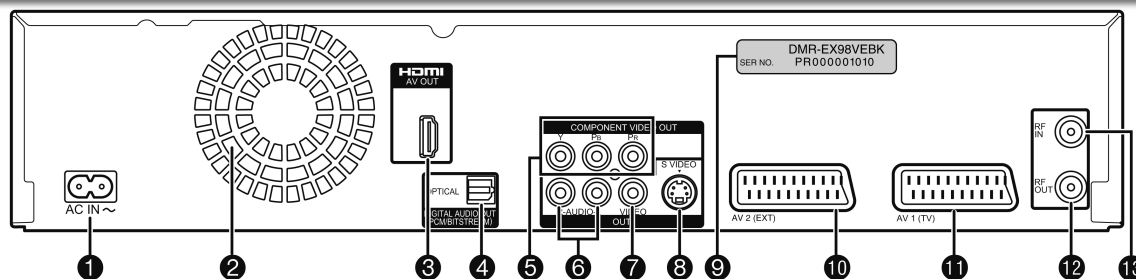

- |  |   |
|--|---|
| <p><b>1</b> AC IN~ = Power supply<br/>         Connection for the AC mains lead</p> <p><b>2</b> Cooling fan</p> <p><b>3</b> HDMI AV OUT terminal<br/>         Digital audio and video output terminal</p> <p><b>4</b> Digital audio output terminal</p> <p><b>5</b> COMPONENT VIDEO OUT (PROGRESSIVE/INTERLACE) terminals<br/>         Y = Luminance signal (brightness), P<sub>B</sub> = Chrominance signal (colour difference), P<sub>R</sub> = Chrominance signal (colour difference)</p> | <p><b>6</b> AUDIO output terminals</p> <p><b>7</b> VIDEO output terminal</p> <p><b>8</b> S VIDEO output terminal</p> <p><b>9</b> Serial number</p> <p><b>10</b> AV2 (EXT) 21-pin Scart terminal<br/>         Connection of an external unit</p> <p><b>11</b> AV1 (TV) 21-pin Scart terminal<br/>         TV set connection</p> <p><b>12</b> Aerial output terminal</p> <p><b>13</b> Aerial input terminal</p> |
|--|---|

## 6 Operation Instructions

### 6.1. (DVD) Taking out the Disc from RAM-Drive Unit when the Disc cannot be ejected by OPEN/CLOSE button

#### 6.1.1. (DVD) Forcible Disc Eject

##### 6.1.1.1. (DVD) When the power can be turned off.

1. Turn off the power and press [STOP], [CH UP] keys on the front panel simultaneously for 5 seconds.

##### 6.1.1.2. (DVD) When the power can not be turned off.

1. Press [POWER] key on the front panel for over 10 seconds to turn off the power forcibly, and press [STOP] [CH UP] keys on the front panel simultaneously for 5 seconds.

#### 6.1.2. (DVD) When the Forcible Disc Eject can not be done.

**Caution!**

1: If you push strong and move the Slide Cam to counter direction of the arrow, the Stopper will be bended and Slide Cam won't stop at Stopper and will reach position for taking out Traverse Base. And Traverse Base might fall down later.

Absolutely, please do not move Slid Cam in the counter direction of the arrow.

**NG Position (Traverse Base might fall down later)**

If you move the Slide Cam to counter direction of the arrow, Slide Cam won't stop at Stopper and will reach position for taking out Traverse Base. And Traverse Base might fall down later.

Before fall down of Traverse Base	After fall down of Traverse Base

2: Moreover, the slide cam will be on irregular position against condition of the shipment if the tray is pushed by the hand after manual tray ejection is done, the hold of traverse Base becomes imperfect, and the danger of fall of traverse Base increases.

Absolutely, complete close of tray by electricity after manual tray ejection was done.  
(Especially finish CLOSE function of tray by electricity when the product will be transported after inspection.)

1. Turn off the power and pull out AC cord.
2. Remove the Top Case.
3. Push in SLIDE CAM by Eject Pin (JZS0484) or minus screw driver (small) to eject tray slightly.

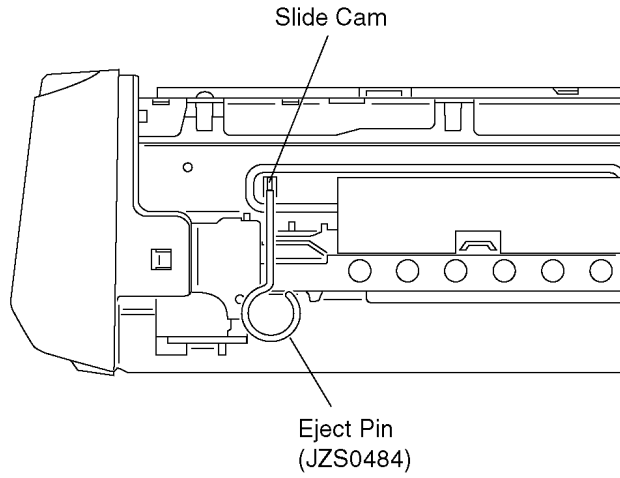

4. Push out Tray by Eject Pin (JZS0484) or minus screw driver (small).

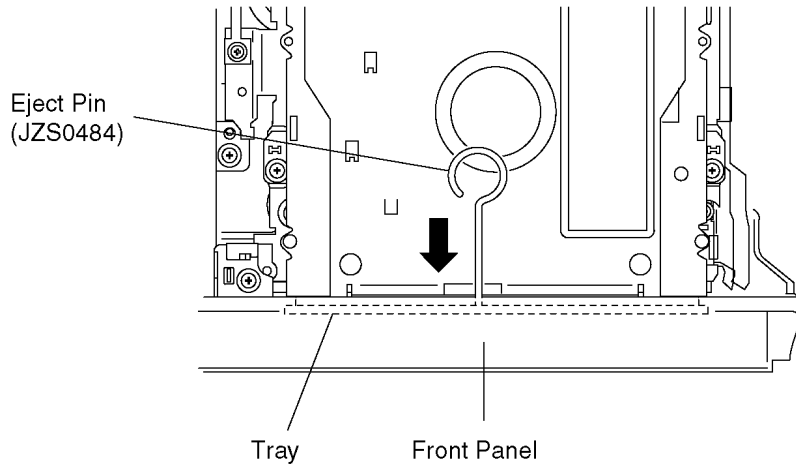

## 6.2. (VHS) Removing Cassette Tape manually

When the cassette tape could not be uninstalled from an electrical malfunction, there are 2 ways to remove a cassette tape.

### 6.2.1. (VHS) Removal by compulsory unloading.

If Service Mode can be activated when the power can not be turned on, this operation is able.

1. Press [STOP] and [EJECT] button simultaneously for more than 3 seconds to turn the unit in VHS service mode.
2. Press [STOP] and [EJECT] button simultaneously 7 times to turn the unit in VHS Service Mode "7".
3. Press [STOP] button in order to unload the mechanism. (Pay attention to tape slack)

#### Service Mode Display:

7 \*\* \*(STOP) → 7 0L \*\* (EJECT)

### 6.2.2. (VHS) Removal by manual operation by rotating the Loading Motor with the batteries.

1. Disconnect the AC plug, and remove the Top Panel and the Front Panel by referring to the Disassembly Procedures.
2. Connect three batteries (1.5V spec.) to the Loading Motor in series for supplying 4.5V to rotate the Loading Motor as shown below.

#### CONNECTION for UNLOADING

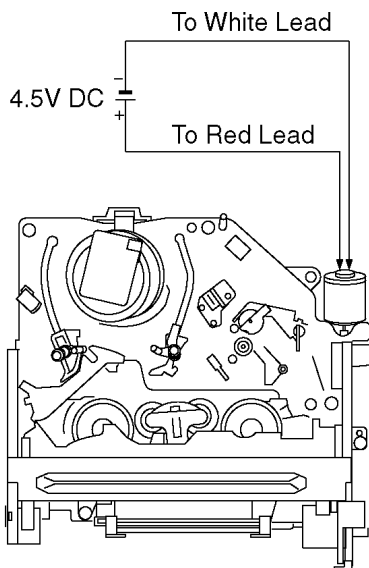

3. Stop unloading just before unloading will be completed as shown below, and then the tape becomes slack as shown below.
4. Rotate the S-Reel by a small minus screwdriver to remove the slack tape as shown below.

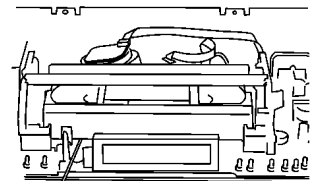
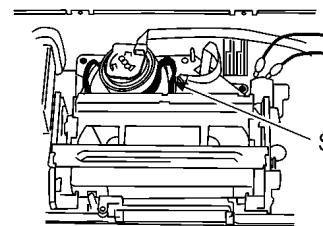
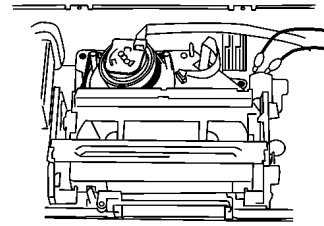

Minus Screw Driver (Small)

5. Then unload again to remove the cassette tape as shown below.

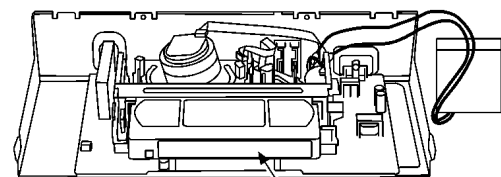

Cassette Tape

### 6.2.3. (VHS) Take out Cassette Tape manually after removing the mechanism

1. Disconnect the AC plug, and remove the Top Panel, Front Panel and the Mechanism by referring to "9 Assembling and Disassembling"
2. Remove the Screw and remove the Loading Motor as shown below.

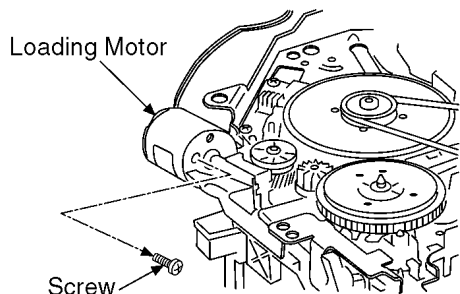

3. Rotate the Main Cam Gear counter-clockwise until just before the unloading will be completed as shown below.

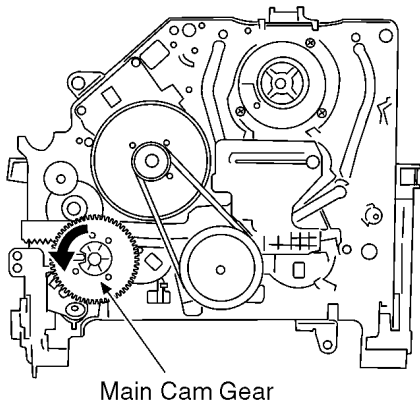

4. Rotate the Capstan Motor clockwise to remove the slack tape as shown below.
5. Rotate the Main Cam Gear counter-clockwise again to remove the cassette-tape as shown below.

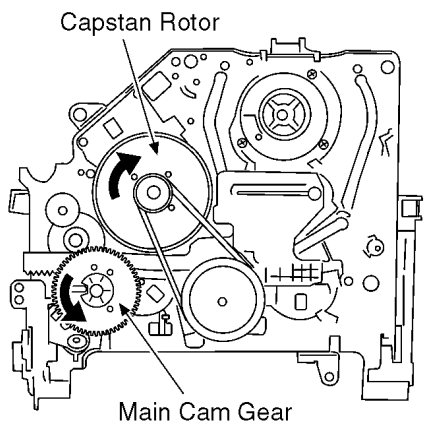

6. Attach Loading Motor and tighten the screw.
7. Set the Position Switch to EJECT POSITION certainly and attach the mechanism to chassis as shown below.

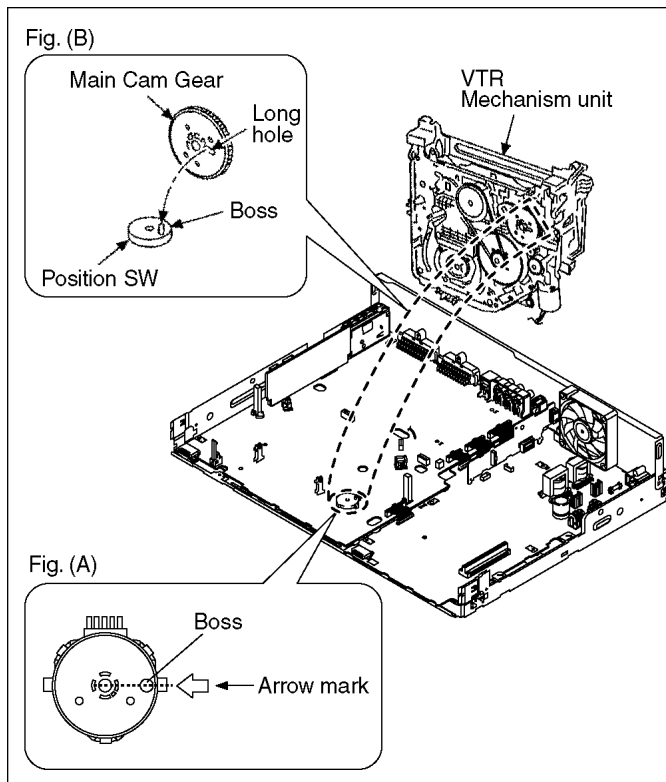

## 7 Service Mode

### 7.1. (DVD) Self-Diagnosis and Special Mode Setting

#### 7.1.1. (DVD) Self-Diagnosis Functions

Self-Diagnosis Function provides information for errors to service personnel by "Self-Diagnosis Display" when any error has occurred.

**U\*\*, H\*\* and F\*\* are stored in memory and held.**

You can check latest error code by transmitting [0] [1] of Remote Controller in Service Mode.

Automatic Display on FL will be cancelled when the power is turned off or AC input is turned off during self-diagnosis display is ON.

Error Code	Diagnosis contents	Description	Monitor Display	Automatic FL display
U30	Remote control code error	Display appears when main unit and remote controller codes are not matched.	No display	<div style="border: 1px solid black; padding: 5px; text-align: center;">DVD *</div> "**" is remote controller code of the main unit. Display for 5 seconds.
U50 (For EG only)	Antenna Short	U50 is displayed when a short circuit was detected at Antenna Input while "Active Antenna" of "Connection" of "FUNCTION MENU" is ON,  And then "Active Antenna" is compulsorily switched to "Off".	"A short circuit was detected at the antenna input. Please check your antenna."	<div style="border: 1px solid black; padding: 5px; text-align: center;">U50</div>
U59	Abnormal inner temperature detected	Display appears when internal temperature of deck reaches limit temperature. The power is turned off forcibly. For 30 minutes after this, all key entries are disabled. (Fan motor operates at the highest speed for the first 5 minutes. For the remaining 25 minutes, fan motor is also stopped.) The event is saved in memory as well.	No display	<div style="border: 1px solid black; padding: 5px; text-align: center;">U59</div> U59 is displayed for 30 minutes.
U61	The unit is carrying out its recovery process. (with no disc in the disc tray)	<ul style="list-style-type: none"> <li>• The unit detected an error while recording or playing with no disc in the disc tray.</li> </ul> The unit is carrying out its recovery process. This process restores the unit to normal operation. The unit is not broken. Wait until the message disappears.	No display	<div style="border: 1px solid black; padding: 5px; text-align: center;">U61</div>
U71	HDMI incompatible error (HDCP incompatible)	Display this error when the equipment (compatible with DVI such as TV, amplifier etc.) connected to the unit by HDMI is incompatible with HDCP. *HDCP=High-bandwidth Digital Content Protection	No display	<div style="border: 1px solid black; padding: 5px; text-align: center;">U71</div>
U72	HDMI connection error (communication error)	This error is displayed when there are any communication problems with the unit and the equipments (TV, amplifier etc.) connected to the unit by HDMI. (or when there is a problem with the HDMI cable)		<div style="border: 1px solid black; padding: 5px; text-align: center;">U72</div> U72 display disappears when error has been solved by Power OFF/ON of connecting equipment or by inserting/removing of HDMI cable.
U73	HDMI connection error (authentication error)	When authentication error occurs while the equipments (TV, amplifier etc.) are connected by HDMI. (or when there is a problem with the HDMI cable)	No display	<div style="border: 1px solid black; padding: 5px; text-align: center;">U73</div> U73 display disappears when error has been solved by Power OFF/ON of connecting equipment or by inserting/removing of HDMI cable.
U80	ST Microprocessor Communication Error on Timer Bus	Display appears when ST Microprocessor Communication Error on Timer Bus occurs.	No display	<div style="border: 1px solid black; padding: 5px; text-align: center;">U80</div> U80 is displayed till Power Key is pressed.

Error Code	Diagnosis contents	Description	Monitor Display	Automatic FL display
U81	ST Microprocessor Communication Error on UART	Display appears when ST Microprocessor Communication Error on DART occurs.	No display	<div style="border: 1px solid black; padding: 5px; text-align: center;">U81</div> U81 is displayed till Power Key is pressed.
U88	The unit is carrying out its recovery process. (with a disc in the disc tray)	<ul style="list-style-type: none"> <li>The unit detected an error while recording or playing with a disc in the disc tray.</li> <li>The unit is carrying out its recovery process. This process restores the unit to normal operation. The unit is not broken. Wait until the message disappears.</li> </ul>	No display	<div style="border: 1px solid black; padding: 5px; text-align: center;">U88</div>
U99	Hang-up	Displayed when communication error has occurred between Main microprocessor and Timer microprocessor.	No display	<div style="border: 1px solid black; padding: 5px; text-align: center;">U99</div> Displayed is left until the [POWER] key is pressed.
H19	Inoperative fan motor	When inoperative fan motor is detected after powered on, the power is turned off automatically. The event is saved in memory.	No display	No display
F00	No error information	Initial setting for error code in memory (Error code Initialization is possible with error code initialization and main unit initialization.)	No display	No display
F58	Drive hardware error	When drive unit error is detected, the event is saved in memory.	No display	No display
F60	DVD module has not been started.	Defect of Digital P.C.B., defect of regulator circuit for Digital P.C.B. and so on. Mode: No change	No display	<div style="border: 1px solid black; padding: 5px; text-align: center;">F60</div>
F34	Initialization error when main microprocessor is started up for program recording	When initialization error is detected after starting up main microprocessor for program recording, the power is turned off automatically. The event is saved in memory.	No display	No display
F74	HDMI Device Key Communication error.	HDMI connection could not be authenticated due to a transfer malfunction. Factor of HDMI Device key-road failure <ul style="list-style-type: none"> <li>When HDMI LSI is damaged.</li> <li>When the bus line of I2C doesn't operate normally.</li> <li>When device key information recorded is damaged.</li> </ul>	No display	<div style="border: 1px solid black; padding: 5px; text-align: center;">F74</div>
F75	HDMI Device Key Information error	HDMI connection could not be authenticated due to an internal data malfunction. Factor of HDMI Device key-road failure <ul style="list-style-type: none"> <li>When HDMI LSI is damaged.</li> <li>When the bus line of I2C doesn't operate normally.</li> <li>When device key information recorded is damaged.</li> </ul>	No display	<div style="border: 1px solid black; padding: 5px; text-align: center;">F75</div>
UNSUPPORT	Unsupported disc error	<ul style="list-style-type: none"> <li>An unsupported format disc was played, although the drive starts normally.</li> <li>The data format is not supported, although the media type is supported.</li> <li>Exceptionally in case of the disc is dirty.</li> </ul>	"This disc is incompatible."	<div style="border: 1px solid black; padding: 5px; text-align: center;">UNSUP</div> <div style="text-align: center;">↓</div> <div style="border: 1px solid black; padding: 5px; text-align: center;">PORT</div> Display for 5 seconds.
NO READ	Disc read error	<ul style="list-style-type: none"> <li>A disc is flawed or dirty.</li> <li>A poor quality failed to start.</li> <li>The track information could not be read.</li> </ul>	"Cannot read. Please check the disc."	<div style="border: 1px solid black; padding: 5px; text-align: center;">NoREAD</div>
HARD ERR	Drive error	The drive detected a hard error.	"DVD drive error."	Display for 5 seconds. <div style="border: 1px solid black; padding: 5px; text-align: center;">HARD</div> <div style="text-align: center;">↓</div> <div style="border: 1px solid black; padding: 5px; text-align: center;">ERR</div>

Error Code	Diagnosis contents	Description	Monitor Display	Automatic FL display
SELF CHECK	Restoration operation	Since the power cord fell out during a power failure or operation, it is under restoration operation. *It will OK, if a display disappears automatically. If a display does not disappear, there is the possibility that defective Digital P.C.B. / RAM drive.	No display	SELF ↓ CHECK
PLEASE WAIT	Unit is in termination process	Unit is in termination process now. "BYE" is displayed and power will be turned off. In case "Quick Start" of setup menu is ON, it is displayed in restoration operation for AC off.	No display	PLEASE ↓ WAIT
UNFORM AT	Unformatted disc error	You have inserted an unformatted DVD-RAM or DVD-RW that is unformatted or recorded on other equipment.	Format This disc is not formatted properly. Format the disc in DISK MANAGEMENT?	UNFOR ↓ MAT
IR ERR	IR communication error	[IR ERR] is displayed when communication between Timer microprocessor and IR microprocessor fails.	No display	IR ERR
No REC	Recording is impossible	[No REC] is displayed when recording is impossible due to the defect, dirt or wound of media.	No display	NoREC
HDD ERROR	[HDD ERR] is displayed when start up of HDD was failed. (Except error of setting of Power on Stand-by)	a) When normal start up was failed. b) When start up at HDD boot was failed. c) When start up from state of P-OFF was failed. d) When start up from state of HDD SLEEP was failed. [HDD ERR] is displayed when above each start up of HDD was failed. *In case b), tray opens automatically and [HDDERR] is displayed until version up disc is inserted.	No display	HDDERR
HDD NG	Power on Stand-by setting error	[HDD NG] is displayed when power on Stand-by setting of HDD is NG or when HDD which power on Stand-by is not set to is used. Please try to replace HDD with genuine HDD as service parts.	No display	HDD NG

### 7.1.2. (DVD) Special Modes Setting

Item		FL display	Key operation
Mode name	Description		Front Key
TEST Mode	*All the main unit's parameters (include tuner) are initialized.	TM*AV1	Press [VHS to DVD COPYING], [REC] and [OPEN/CLOSE] keys simultaneously for five seconds when power is off.
Rating password	The audiovisual level setting password is initialized to "Level 8".	INIT	Open the tray, set DRIVE SELECT to DVD, and press [REC] and [PLAY] simultaneously for 5 seconds.
Service Mode	Setting every kind of modes for servicing. *Details are described in "7.1.3. (DVD) Service Mode at a glance".	SERV	When the power is off, press [VHS to DVD COPYING], [OPEN/CLOSE] and [STOP] keys simultaneously for 5 seconds.
Forced disc eject	Removing a disc that cannot be ejected. The tray will open and unit will shift to P-off mode. *When Timer REC is ON or EXT-LINK is ON, execute " Forced disc eject " after releasing Timer REC or EXT-LINK. *This command is not effective during "Child lock" is ON. While Demonstration Lock is being set, this Forced disc eject function is not accepted.  If this command was executed while TIMER REC is being set, TIMER REC setting will be kept.	The display before execution leaves.  *****	When the power is off, press [STOP] and [CH UP] keys simultaneously for 5 seconds.







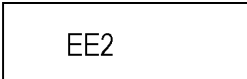
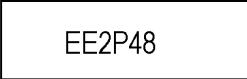

Item		FL display	Key operation
Mode name	Description		Front Key
Child lock/unlock	Set or release "Child Lock".	X HOLD	Press [ENTER] and [RETURN] by remote controller simultaneously until [X-HOLD] is displayed.
NTSC/PAL system select	To switch PAL/NTSC alternately.	The display before execution leaves. *****	While the power is on (E-E mode), press [STOP] and [OPEN/CLOSE] simultaneously for 5 seconds.
Forced power-off	When the power button is not effective while power is ON, turn off the power forcibly. *When Timer REC is ON or EXT-LINK is ON, execute "Forced Power-off" after releasing Timer REC or EXT-LINK.	Display in P-off mode.	Press [Power] key over than 10 seconds.
Aging	Perform sequence of modes as * Aging Description shown below continually. <b>Caution:</b> <b>All programs in DVD-RAM disc will be deleted because Formatting is done once in Aging process.</b>	Display following the then mode.	Set DRIVE SELECT to DVD. When the power is ON, press [CH DOWN], [VHS to DVD COPYING] and [OPEN/CLOSE] simultaneously for over 5 seconds and less than 10 seconds. <b>NOTE1:</b> If Unit has not turned into Aging mode by operations shown above, execute TEST MODE once and re-execute operation shown above. (*All the main unit's parameters include tuner are initialized by TEST mode.) <b>NOTE2:</b> If the unit has hung-up because of pressing keys for over 10 seconds, once turn off the power, and re-execute this command. *When releasing Aging mode, press [POWER] key, AC-OFF.
<b>Aging Contents (Example):</b>			
<div style="border: 1px dashed black; padding: 10px; text-align: center;"> <pre> Format → REC → STOP → PLAY → CUE → REV → PLAY → PAUSE   * - ↑ - CLOSE ← OPEN ← STOP ← PLAY ← R-SLOW ← SLOW ←</pre> </div> <p>*XP mode . . . . . repeat twice  SP mode . . . . . repeat 4 times  LP mode . . . . . repeat 8 times  EP mode . . . . . repeat 12 times</p>			
Demonstration lock/unlock	Ejection of the disc is prohibited. The lock setting is effective until unlocking the tray and not released by "Main unit initialization" of service mode.	*When lock the tray. LOCK "LOCK" is displayed for 3 seconds.	When the power is on, press [STOP] and [POWER] keys simultaneously for 5 seconds in the condition that a disc in the tray. <b>NOTE:</b> Time difference between pressing [STOP] and [POWER] should be within 0.5 sec.
		*When unlock the tray. UNLOCK "UNLOCK" is displayed for 3 seconds.	When the power is on, press [STOP] and [POWER] keys simultaneously for 5 seconds while the tray being locked. <b>NOTE:</b> Time difference between pressing [STOP] and [POWER] should be within 0.5 sec.
		*When press OPEN/CLOSE key while the tray being locked. LOCK Display "LOCK" for 3 seconds.	Press [OPEN/CLOSE] key while the tray being locked.
ATP re-execution	Re-execute ATP.	Display at ATP executing. *****	When the power is on (E-E mode), press [CH UP] and [CH DOWN] simultaneously for 5 seconds.

Item		FL display	Key operation
Mode name	Description		Front Key
Progressive initialization	The progressive setting is initialized to Interlace.	The display before execution leaves. <div style="border: 1px solid black; padding: 5px; width: fit-content; margin: 0 auto;">*****</div>	When the power is on (E-E mode), press [STOP] and [VHS to DVD COPYING] simultaneously for 5 seconds.

### 7.1.3. (DVD) Service Modes at a glance

Service mode setting: While the power is off, press [STOP], [VHS to DVD COPYING] and [OPEN / CLOSE] simultaneously for five seconds.

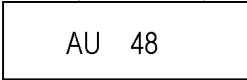
Item		FL display	Key operation
Mode name	Description		(Remote controller key)
Release Items	Item of Service Mode executing is cancelled.	SERV	Press [0] [0] or [Return] in service mode.
Error Code Display	Last Error Code of U/H/F held by Timer is displayed on FL. *Details are described in "7.1.1. (DVD) Self-Diagnosis Functions".	♣ □ □  * ♣ shows U/H/F. □ □ shows number.  If any error history does not exist, [F00] is displayed.	Press [0] [1] in service mode
ROM Version Display	1. Region code (displayed for 5 sec.) 2. Main firm version (displayed for 5 sec.) 3. Timer firm version (displayed for 5 sec.) 4. Drive firm version (displayed for 5 sec.) 5. ROM correction version (displayed for 5 sec.) 6. VHS Microprocessor version (displayed for 5 sec.) 7. VHS ROM correction version (displayed for 5 sec.) 8. ST Microprocessor version (left displayed)	1. NO * *: Region of DVD (Example: 1,2.....) 2. ***** 3. ***** 4. ***** 5. *** 6. ***** 7. ** 8. ST ***  * are version displays.	Press [0] [2] in service mode
White Picture Output	White picture is output as component Output from AV Decoder. *White picture (Saturation rate : 100%) *It is enable to switch Interlace/Progressive by "I/P switch: [1] [4]"	*Initial mode is "Interlace". WHIT I	Press [1] [1] in service mode.
		Switch Interlace/Progressive WHIT	Press [1] [4] in White Picture Output mode. *I/P are switched alternately.
Magenta Picture Output	Magenta picture is output with Component Output from AV Decoder. *Magenta picture (Saturation rate: 100%) *It is enable to switch Interlace/Progressive by "I/P switch: [1] [4]"	*Initial mode is "Interlace". MAGE I	Press [1] [2] in service mode.
		Switch Interlace/Progressive MAGE	Press [1] [4] in Magenta Picture Output mode. *I/P are switched alternately.





Item		FL display	Key operation
Mode name	Description		(Remote controller key)
RTSC Return in XP (A & V)	AV1 input signal is encoded (XP), decoded (XP) and output decoded signal to external without DISC recording and DISC playback.	Initial mode: EE2/ Interlace/ XP/ Audio 48kHz 	Press [1] [3] in service mode.
		Switch Interlace/Progressive 	Press [1] [4] in RTSC Return XP mode. *I/P are switched alternately.
		Audio 44.1 kHz/ 48 kHz Switch 	Press [2] [4] in RTSC Return XP mode. *48 kHz / 44.1 kHz are switched alternately.
I/P Switch	Switch Interlace and Progressive in EE mode. *Initial setting is "Interlace". *This command is effective during executing "White Picture Output", "Magenta Picture Output" and "RTSC Return in XP (A & V)" modes.	Initial mode is Interlace 	Press [1] [4] in I/P Switch mode. *I/P are switched alternately.
		Switch Interlace/Progressive 	
Audio Mute (XTMUTE)	Check whether mute is applied normally by the timer microprocessor.		Press [2] [1] in service mode.
Audio Mute (XDMUTE)	Check whether mute is applied normally by the Digital P.C.B..		Press [2] [2] in service mode.
Audio Pattern Output	The audio pattern stored in the internal memory is output (Lch: 1kHz/-18dB) (Rch: 400Hz/-18dB) *Audio sound clock switching operation of DAC can be confirmed by sub command [2] [4].	Initial mode (Audio 48kHz) 	Press [2] [3] in service mode.
		Audio 44.1kHz/48kHz switching 	Press [2] [4] in Audio Pattern Output mode. *48 kHz / 44.1 kHz are switched alternately.

Item		FL display	Key operation (Remote controller key)
Mode name	Description		
HDD READ SEEK Inspection	Inspecting seek time of HDD to inspect performance.	<p>At start</p> <div style="text-align: center;"> <div style="border: 1px solid black; padding: 5px; width: fit-content; margin: 0 auto;">AVSCAN</div> <div style="text-align: center;">↓</div> <div style="border: 1px solid black; padding: 5px; width: fit-content; margin: 0 auto;">* 00</div> <div style="text-align: center;">↓</div> </div> <p>The [*] sign is added every 20 seconds while inspecting. Two digits on the right side are the progress level of the inspection (The unit is %). Example on the way of inspection:</p> <div style="text-align: center;"> <div style="border: 1px solid black; padding: 5px; width: fit-content; margin: 0 auto;">*** 53</div> </div> <p>When HDD is OK after inspection:</p> <div style="text-align: center;"> <div style="border: 1px solid black; padding: 5px; width: fit-content; margin: 0 auto;">HDD OK</div> </div> <p>(NG is displayed when error is excluding o ) (Transfer rate is calculated from the AV scanning result, and when it is less than 35Mbps, NG is displayed.)</p> <div style="text-align: center;"> <div style="border: 1px solid black; padding: 5px; width: fit-content; margin: 0 auto;">HDD \$##</div> </div> <p>\$. [X] is displayed when seek time is over 270msec., there is error or transfer rate is NG. Position at \$ is space when excluding those. ##: Number of data of over 100msec. and less than 270msec. When it is over 100, [99] is displayed. When the number is less than 5, we judge it normal.</p>	<p>Press [3] [1] in service mode. * When cancelling the inspection mode while executing, do "forced power-off". Method: Press [POWER] key more than 10 seconds.</p>

Item		FL display	Key operation (Remote controller key)
Mode name	Description		
HDD READ VERIFY Inspection	Measure of access time in READ VERIFY MODE of HDD.	<p>At start</p> <div style="text-align: center;"> <div style="border: 1px solid black; padding: 5px; width: fit-content; margin: 0 auto;">AVSCAN</div> <p style="text-align: center;">↓</p> <div style="border: 1px solid black; padding: 5px; width: fit-content; margin: 0 auto;">* 00</div> <p style="text-align: center;">↓</p> </div> <p>The [*] sign is added every 20 seconds while inspecting. Two digits on the right side are the progress level of the inspection (The unit is %). Example on the way of inspection:</p> <div style="text-align: center;"> <div style="border: 1px solid black; padding: 5px; width: fit-content; margin: 0 auto;">*** 53</div> </div> <p>When HDD is OK after inspection:</p> <div style="text-align: center;"> <div style="border: 1px solid black; padding: 5px; width: fit-content; margin: 0 auto;">HDD OK</div> </div> <p>(NG is displayed when error is excluding o ) (Transfer rate is calculated from the AV scanning result, and when it is less than 35Mbps, NG is displayed.)</p> <div style="text-align: center;"> <div style="border: 1px solid black; padding: 5px; width: fit-content; margin: 0 auto;">HDD \$##</div> </div> <p>\$: [X] is displayed when seek time is over 270msec., there is error or transfer rate is NG. Position at \$ is space when excluding those. ##: Number of data of over 100msec. and less than 270msec. When it is over 100, [99] is displayed. When the number is less than 5, we judge it normal.</p>	<p>Press [3] [2] in service mode. * When cancelling the inspection mode while executing, do "forced power-off". Method: Press [POWER] key more than 10 seconds.</p>
HDD Spin-up time	The accumulation value of the Spin-up time of HDD is displayed.	<div style="text-align: center;"> <div style="border: 1px solid black; padding: 5px; width: fit-content; margin: 0 auto;">*****</div> </div> <p>Spin-up time of HDD is displayed. (The unit of display is hour.)</p>	<p>Press [3] [3] in service mode.</p>

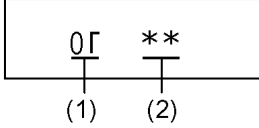
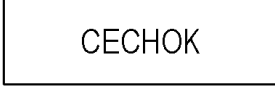
Item		FL display	Key operation (Remote controller key)
Mode name	Description		
HDD High Speed Scan	High speed AV scan check of HDD	<div style="text-align: center;"> <div style="border: 1px solid black; padding: 5px; width: fit-content; margin: 0 auto;">AVSCAN</div> <p style="text-align: center;">↓</p> <div style="border: 1px solid black; padding: 5px; width: fit-content; margin: 0 auto;">* 00</div> <p style="text-align: center;">↓</p> <p>The [*] sign is added every 10 seconds while inspecting. Two digits on the right side are the progress level of the inspection (The unit is %). Example on the way of inspection:</p> <div style="border: 1px solid black; padding: 5px; width: fit-content; margin: 0 auto;">*** 53</div> <p>When HDD is OK after inspection:</p> <div style="border: 1px solid black; padding: 5px; width: fit-content; margin: 0 auto;">HDD OK</div> <p>When HDD is NG after inspection:</p> <div style="border: 1px solid black; padding: 5px; width: fit-content; margin: 0 auto;">HDD ***</div> <p>[*] is the number of data of NG.</p> </div>	Press [3] [6] in service mode.
HDD Check	Simple quality judgment of HDD	<div style="text-align: center;"> <div style="border: 1px solid black; padding: 5px; width: fit-content; margin: 0 auto;">HDDCHK</div> <p style="text-align: center;">↓</p> <p>When HDD is OK:</p> <div style="border: 1px solid black; padding: 5px; width: fit-content; margin: 0 auto;">HDD OK</div> <p>When HDD is NG:</p> <div style="border: 1px solid black; padding: 5px; width: fit-content; margin: 0 auto;">HDD NG</div> </div>	Press [3] [7] in service mode.
Laser Used Time Indication	Check laser used time (hours) of drive.	<div style="text-align: center;"> <div style="border: 1px solid black; padding: 5px; width: fit-content; margin: 0 auto;">*</div> <p>●(****) is the used time display in hour. ●Laser used time of DVD/ CD in Playback/Recording mode is counted.</p> </div>	Press [4] [1] in service mode.

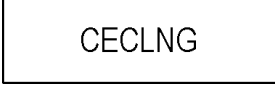
Item		FL display	Key operation															
Mode name	Description		(Remote controller key)															
RAM Drive Last Error	RAM Drive error code display. *For details about the drive error code, refer to the Service Manual for the specific RAM Drive.	<p>1. Error Number is displayed for 5 seconds.</p> <div style="border: 1px solid black; padding: 5px; text-align: center;">NO **</div> <p>2. Time when the error has occurred is displayed for 5 seconds.</p> <div style="border: 1px solid black; padding: 5px; text-align: center;">DDhhmm</div> <p>DD: Day hh: Hour mm: Minute</p> <p>3. Last Drive Error (1/2) is displayed for 5 seconds.</p> <div style="border: 1px solid black; padding: 5px; text-align: center;">***** ↑</div> <p>03: Bad disc 04: Bad disc or drive malfunction</p> <p>4. Last Drive Error (2/2) is displayed for 5 seconds.</p> <div style="border: 1px solid black; padding: 5px; text-align: center;">*****</div> <p>5. Error occurring Disc type is displayed for 5 seconds.</p> <div style="border: 1px solid black; padding: 5px; text-align: center;">*****</div> <p>6. Disc Maker ID is displayed for 5 seconds.</p> <div style="border: 1px solid black; padding: 5px; text-align: center;">*****</div> <p>7. Factor of Drive Error occurring is left displayed</p> <div style="border: 1px solid black; padding: 5px; text-align: center;">*****</div>	<p>Press [4] [2] in service mode. When "INFO*****" is being displayed, past 19 error histories can be displayed by pressing [0] [1] - [1] [9]</p> <p>In case that the maker cannot be identified, display is black out.</p>															
Laser power confirmation	Drive state is judged based on difference between laser power value at shipping and present laser power value.	<div style="border: 1px solid black; padding: 5px; text-align: center;">CHK *</div> <p>* is judgment result</p> <table border="1" style="margin-left: auto; margin-right: auto;"> <thead> <tr> <th>*</th> <th>Power value difference</th> <th>Evaluation</th> </tr> </thead> <tbody> <tr> <td>0</td> <td>1mW or less</td> <td>Very good.</td> </tr> <tr> <td>1</td> <td>2mW or less</td> <td>Good.</td> </tr> <tr> <td>2</td> <td>3mW or less</td> <td>Bad.</td> </tr> <tr> <td>3</td> <td>4mW or more</td> <td>Very bad.</td> </tr> </tbody> </table> <p>If DVD-RAM disc is not inserted, [NO DISC] is displayed. If power value study was filed, [ERROR] is displayed.</p>	*	Power value difference	Evaluation	0	1mW or less	Very good.	1	2mW or less	Good.	2	3mW or less	Bad.	3	4mW or more	Very bad.	<p>1. Insert DVD-RAM disc into RAM Drive in service mode. (Other media are assumed to be non-correspondence.)</p> <p>2. Press [4] [4].</p>
*	Power value difference	Evaluation																
0	1mW or less	Very good.																
1	2mW or less	Good.																
2	3mW or less	Bad.																
3	4mW or more	Very bad.																
Turn on all FL/LEDs	All segments of FL and all LEDs are turned on.	All segments are turned on.	Press [5] [1] in service mode.															
PB HIGH Signal Output	8 pin of AV 1 Jack (PB HIGH terminal) is High (approx. 11V DC).	<div style="border: 1px solid black; padding: 5px; text-align: center;">PB HI</div>	Press [5] [2] in service mode.															
PB MIDDLE Signal Output	8 pin of AV 1 Jack (PB HIGH terminal) is Middle (approx. 5.5V DC)	<div style="border: 1px solid black; padding: 5px; text-align: center;">PB MID</div>	Press [5] [3] in service mode.															

Item		FL display	Key operation (Remote controller key)
Mode name	Description		
Front connection inspection	Press all front keys and check the connection between Main P.C.B. and Front key Switches.	 <p>(1) Each time a key is pressed, segment turned on increases one by one. (2) Total number of keys that have been pressed.</p>	Press [5] [4] in service mode.
CEC (H) output	Check of the CEC terminal high output of HDMI.	<p>When the check is OK</p>  <p>When the check is NG</p> 	Press [5] [5] in service mode.
CEC (L) output	Check of the CEC terminal low output of HDMI.	<p>When the check is OK</p>  <p>When the check is NG</p> 	Press [5] [6] in service mode.
Production Date Display	Display the date when the unit was produced.	 <p>YY: Year MM: Month DD: Day</p>	Press [6] [1] in service mode.
Display the accumulated working time	Display the accumulated unit's working time.	 <p>(Indicating unit: Second)</p>	Press [6] [4] in service mode.

Item		FL display	Key operation
Mode name	Description		(Remote controller key)
Display the Error History	Display the Error History stored on the unit.	Display reason of error for 5 seconds. <div style="border: 1px solid black; padding: 5px; width: fit-content; margin: 5px auto;">NO **</div> 01: Defect of Digital P.C.B. (AV DEC / MAIN CPU) 02: Defect of RAM Drive. 03: Defect of Disc. 04: Defect of Digital P.C.B. or Communication Error. 05: Defect of Digital P.C.B. (AV DEC / MAIN CPU) 06: Defect of HDD.  Display the time when the error has occurred for 5 seconds. <div style="border: 1px solid black; padding: 5px; width: fit-content; margin: 5px auto;">DDhhmm</div> DD: Day hh: Hour mm: Minute Accumulated working time till occurring of the error is left displayed. <div style="border: 1px solid black; padding: 5px; width: fit-content; margin: 5px auto;">*****</div> (Indicating unit: Second)	Press [6] [5] in service mode. Then press [0] [1] ~ [9] [9], the past 99 error histories are displayed.
SD card WRITE check	Delete Error History information stored on the unit.	When the WRITE check is OK. <div style="border: 1px solid black; padding: 5px; width: fit-content; margin: 5px auto;">SD OK</div> When the WRITE check is NG. <div style="border: 1px solid black; padding: 5px; width: fit-content; margin: 5px auto;">SD NG</div> <b>*Note:</b> The image stored in the SD card will be erased.	Insert a SD card to SD card slot, and press [7] [4] in service mode. *Insert SD card while the power is off. *Check for [CARD SD] display on the FL display and go on the procedure.
USB check	Display the volume label of the USB memory.	When USB memory is not connected. <div style="border: 1px solid black; padding: 5px; width: fit-content; margin: 5px auto;">NO USB</div> When USB check is OK. <div style="border: 1px solid black; padding: 5px; width: fit-content; margin: 5px auto;">*****</div> [*] is volume label. <b>Example of volume label is</b> <b>[PANASONIC] :</b> <div style="border: 1px solid black; padding: 5px; width: fit-content; margin: 5px auto;">PANASO</div> When USB check is NG. <div style="border: 1px solid black; padding: 5px; width: fit-content; margin: 5px auto;">ERROR</div>	Press [7] [5] in service mode.  * Insert USB memory.
AV4(V)/AV1(RGB) Setting	I/O Set input to AV4 (V) and set output to AV1 (RGB) for I/O checking	<div style="border: 1px solid black; padding: 5px; width: fit-content; margin: 5px auto;">PAL 01</div>	Press [8] [0] in service mode.

Item		FL display	Key operation (Remote controller key)
Mode name	Description		
AV2(Y/C)/AV1(V) Setting	I/O Set input to AV2 (Y/C) and set output to AV1 (V) for I/O checking	PAL 02	Press [8] [1] in service mode.
AV2(V)/AV1(Y/C) Setting	I/O Set input to AV2 (V) and set output to AV1 (Y/C) for I/O checking	PAL 03	Press [8] [2] in service mode.
AV2(RGB)/AV1(V) Setting	I/O Set input to AV2 (RGB) and set output to AV1 (V) for I/O checking	PAL 04	Press [8] [3] in service mode.
P50(H) Output	Timer Microprocessor IC9701-76 output High signal for AV1-pin 10 passing through inverter (approx. 0V DC at AV1-pin 10).	When OK. P50HOK When NG. P50HNG	Press [8] [4] in service mode.
P50(L) Output	Timer Microprocessor IC9701-76 output Low signal for AV1-pin 10 passing through inverter (approx. 4.4V DC at AV1-pin 10).	When OK. P50LOK When NG. P50LNG	Press [8] [5] in service mode.
Tray OPEN/CLOSE Test	The tray is opened and closed repeatedly.	***** ** is number of open/close cycle times.	Press [9] [1] in service mode *When releasing this mode, press the [POWER] button of Remote Controller more than 10 seconds.
Delete the Laser Used Time	Laser used time stored in the memory of the unit is deleted.	CLR	Press [9] [5] in service mode.
Delete the Last Drive Error	Delete the Last Drive Error information stored on the DVD RAM-Drive.	CLR	Press [9] [6] in service mode.
Delete the Error History	Delete Error History information stored on the unit.	CLR	Press [9] [7] in service mode.
Error code initialization	Initialization of the last error code held by timer (Write in F00)	CLR	Press [9] [8] in service mode.
Initialize Service	Last Drive Error, Error history and Error Codes stored on the unit are initialized to factory setting.	CLR	Press [9] [9] in service mode.
Finishing service mode	Release Service Mode.	Display in STOP (E-E) mode. *****	Press power button on the front panel or Remote controller in service mode.

## 7.2. (VHS) Self-Diagnosis and Special Mode Setting

### 7.2.1. (VHS) Special Modes Setting

**Note:**

Set DRIVE SELECT to VHS.

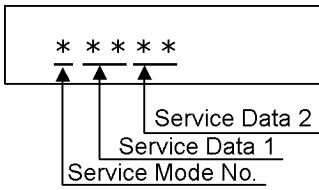
Item		FL display	Key operation
Mode name	Description		Front Key
Tracking Center	Tape Tracking is adjusted to center FIX position.	No display.	During PLAYBACK, press [CH UP] and [CH DOWN] keys simultaneously.
VHS Service Mode	In order to make service easy, a part of inside information of a microprocessor is displayed on FIP. *Details are described in "7.2.2. (VHS) Service Mode".		Press [STOP], and [EJECT] keys simultaneously for 3 seconds when power is off.
Releasing EXT LINK and Timer Program	Releasing Continuation EXT LINK and Timer Program	No display.	While in EXT LINK and Timer REC mode, press [STOP] key for 3 seconds.
Eject	Ejecting Cassette Tape	No display.	While in other than Timer REC mode, press [STOP] key for 3 seconds or press [STOP] key of the Remote Controller for 3 seconds.

## 7.2.2. (VHS) Service Modes

1. Set DRIVE SELECT to VHS.
2. When power is off, press [STOP] and [EJECT] keys simultaneously for 3 seconds to into Service Mode.
3. In service mode, press [STOP] and [EJECT] keys simultaneously to add Service Number.

Service Mode Number	Contents	Contents of Indication on minute	Contents of Indication on second	Remarks
0	Indication for the inner data of IC6001	VHS mode (Real time)	Process number of the mechanism movement (Real time)	
1	Indication for the inner data of IC6001	Tape beginning and ending detection data (Real time) 00: Both tape beginning and ending have not been detected 01: Tape ending is detecting now 02: Tape beginning is detecting now 03: Both tape beginning and ending are detecting now	Key code (Real time) Indicate the receiving code when the key of VCR or remote controller being operated.	
2	Indication for the inner data of IC6001	Mechanism position (Real time) 0L: EJECT position 02: DOWN position 03: RREW position 04: LOAD position 05: REV position 06: PLAY position 07: POFF position 08: STOP_R position 09: STOP_F position 0 - : FF/REW position 0_ : Intermediate between each positions	Ordering for the Motors (Real time) 0*, 2*: CYL off, CAP off 1*: CYL off, CAP on (fwd) 3*: CYL off, CAP on (rev) 8*, A*: CYL on, CAP off 9*: CYL on, CAP on (fwd) B*: CYL on, CAP on (rev) *0: Motor off *1: Loading *2: Unloading *3: Break (Load + Unload)	The following functions are prohibited to operate the mechanism without cassette tape. ●Tape beginning and ending detection. ●Reel lock detection ●Tape detection and tape position detection  Press the EJET key for over 3 seconds in this mode, and then the VCR is shifted into the special modes, such as PG Adjustment, Model Code Setting, and so on. The orders for the motors are as follows.
3	Self-diagnosis history (1st)	1st history of error number	"- -" is displayed.	
4	Self-diagnosis history (2nd)	2nd history of error number	"- -" is displayed	
5	Self-diagnosis history (3rd)	3rd history of error number	"- -" is displayed	
6	Indication for the inner data of IC6001	Servo data (4 digits) (Real time)		
7	Manual mechanism operation	Mechanism position (Real time) 0L: EJECT position 02: DOWN position 03: RREW position 04: LOAD position 05: REV position 06: PLAY position 07: POFF position 08: STOP_R position 09: STOP_F position 0 - : FF/REW position 0_ : Intermediate between each positions	Ordering for the Motors 0*, 2*: CYL off, CAP off 1*: CYL off, CAP on (fwd) 3*: CYL off, CAP on (rev) 8*, A*: CYL on, CAP off 9*: CYL on, CAP on (fwd) B*: CYL on, CAP on (rev) *0: Motor off *1: Loading *2: Unloading *3: Break (Load + Unload)	Press the following key; PLAY key : Loading STOP key : Unloading

### 7.2.3. (VHS) Self-Diagnosis Functions

This model has a self-diagnosis. If the VHS section detects trouble during installation or during use, the power is automatically turned off or become power-save mode and it is memorized into the EEPROM (IC9705) as error code of two-digit number. It's memorized error code can be displayed in "second" display portion (the last 2 digits of the FIP) by placing the unit in Service Mode Number 2 when turning on Service Information Display as for example "01" or "02" etc as below. If a second error occurs, the most recent error will be memorized and can be displayed in Service Mode Number 2. It can be memorized until 3 self-diagnosis histories in maximum.

In order to erase the memorized error code, press STOP and EJECT buttons on the Front Panel simultaneously over 5 seconds during turning on Service Information Display mode.

#### 7.2.3.1. Memory of the self-diagnosis history

\*This is effective only in Service Mode 3, 4, 5.

##### 7.2.3.1.1. Error Numbers at a glance

Memory No. (Error Code)	Reason
01	The cylinder could not be started. (Error of the cylinder or the cylinder driver.)
02	The CAP FG could not be detected.
03	Mechanism lock during without the unloading and the cassette-up.
04	Mechanism lock during unloading
05	S-reel pulse cannot be detected during unloading. (Error of the S-reel circuit or the Capstan circuit)
06	Mechanism lock during the Cassette-up.
09	Communication error between VHS Microprocessor (IC6001) and Timer Microprocessor (IC9701).
15	S-reel pulse cannot be detected when a cassette tape is inserted. (Error of the S-reel circuit or the Capstan circuit)
16	Detection of the Cylinder lock during the constant rotation
17	Detection of S-reel lock during the constant tape running
18	Detection of T-reel lock during the constant tape running
2*	An error while the PG Automatic Adjustment
Refer to following Note	
80	An exceptional ejection depends on a accidental error

#### Note:

2\* is as follows.

20	NG1 in the PG Shifter Automatic Adjustment (The cylinder rotation is unstable during the automatic adjustment.)
21	NG2 in the PG Shifter Automatic Adjustment (The vertical sync signal is lacked while over 5 seconds on the alignment tape.)
22	NG3 in the PG Shifter Automatic Adjustment (The installing position of Heads to the cylinder is out of specification.)
23	NG4 in the PG Shifter Automatic Adjustment (The servo is not locked to the cylinder for more than 10 sec.)

##### 7.2.3.1.2. Memory for the self-diagnosis history

1. The self-diagnosis result is memorized the state of the moment of detecting.
2. There are the histories from number 1 to number 3.
3. The latest error is memorized on history number 1, and then the old histories are shifted to the history number 2 and 3.  
The error code memorized in the history number 2 and 3 is over-written by shift.
4. If the latest error is the same with the history number 1 (2nd-latest), it is not memorized.  
(The same error code is not memorized in succession)

##### 7.2.3.1.3. Clear for the self-diagnosis history

1. Press FF and EJECT buttons on the VCR simultaneously over 5 seconds during turning on Service Information Display mode.

### 7.2.3.1.4. Indication of the self-diagnosis history.

The self-diagnosis histories can be indicated on the FIP with Service Mode number 3 to 5.

The procedure of service mode setting and indication format are the same as usual.

FIP INDICATION:      4                      0                      3                      -                      -

Hour of one-digit	Minute of two-digit	Minute of one-digit	Second of two-digit	Second of one-digit
Service mode number	Error code		-	-
3	Error code of history 1 (The latest)		-	-
4	Error code of history 2 (2nd latest)		-	-
5	Error code of history 3 (3rd latest)		-	-

The Error code of history 1, 2 and 3 can be indicated by selecting the Service mode 3, 4 and 5 as shown above.

In case of no error code in the memory, it is indicated as "00".

## 8 Service Fixture & Tools

(For DVD)

Part Number	Description	Compatibility
RFKZ0168	Extension Cable (Dig. Interface P.C.B. - Fan Motor / 3 Pin)	Same as E50 / ES30V Series
VFK1729	Extension Cable (Dig. Interface P.C.B. - Main P.C.B. / 13 Pin)	Same as E75V/ES30V Series
RFKZ0216	Extension Cable (Main P.C.B. - Dig. Interface P.C.B. / 23 Pin / 40 mm)	Same as E55 Series
RFKZ0240	Extension Cable (Main P.C.B. - Dig. Interface P.C.B. / 19 Pin / 40 mm)	Same as EH75V / ES30V Series
RFKZ0215	Extension Cable (Main P.C.B. - Front Jack P.C.B. / 12 Pin)	Same as ES15 / E55 / ES30V Series
RFKZ0169	Extension Cable (Dig. Interface P.C.B. - HDD / 4 Pin)	Same as EH75V Series
RFKZ0260	Extension Cable (Dig. Interface P.C.B. - RAM/Digital P.C.B. Module / 88 Pin)	Same as ES15 / EH55 Series
JZS0484	Eject Pin	Same as ES15 / E50 Series
RFKZ03D01K	Lead Free Solder (0.3mm/100g Reel)	Same as ES15 Series
RFKZ06D01K	Lead Free Solder (0.6mm/100g Reel)	Same as ES15 Series
RFKZ10D01K	Lead Free Solder (1.0mm/100g Reel)	Same as ES15 Series
RFKZ0316	Solder Remover (Lead free low temperature Solder/50g)	Same as ES15 Series
RFKZ0328	Flux	Same as ES15 Series

(For VHS)

Part Number	Description	Compatibility
VFJ8125H3F	PAL VHS Alignment Tape	Same as E75V / ES30V Series
VFK0329	Post Adjustment Screwdriver	Same as E75V / ES30V Series
VFK0330	Fine Adjustment Gear Driver	Same as E75V / ES30V Series

## 9 Assembling and Disassembling Instructions

### 9.1. Disassembly Flow Chart

The following chart is the procedure for disassembling the casing and inside parts for internal inspection when carrying out the servicing.

To assemble the unit, reverse the steps shown in the chart below.

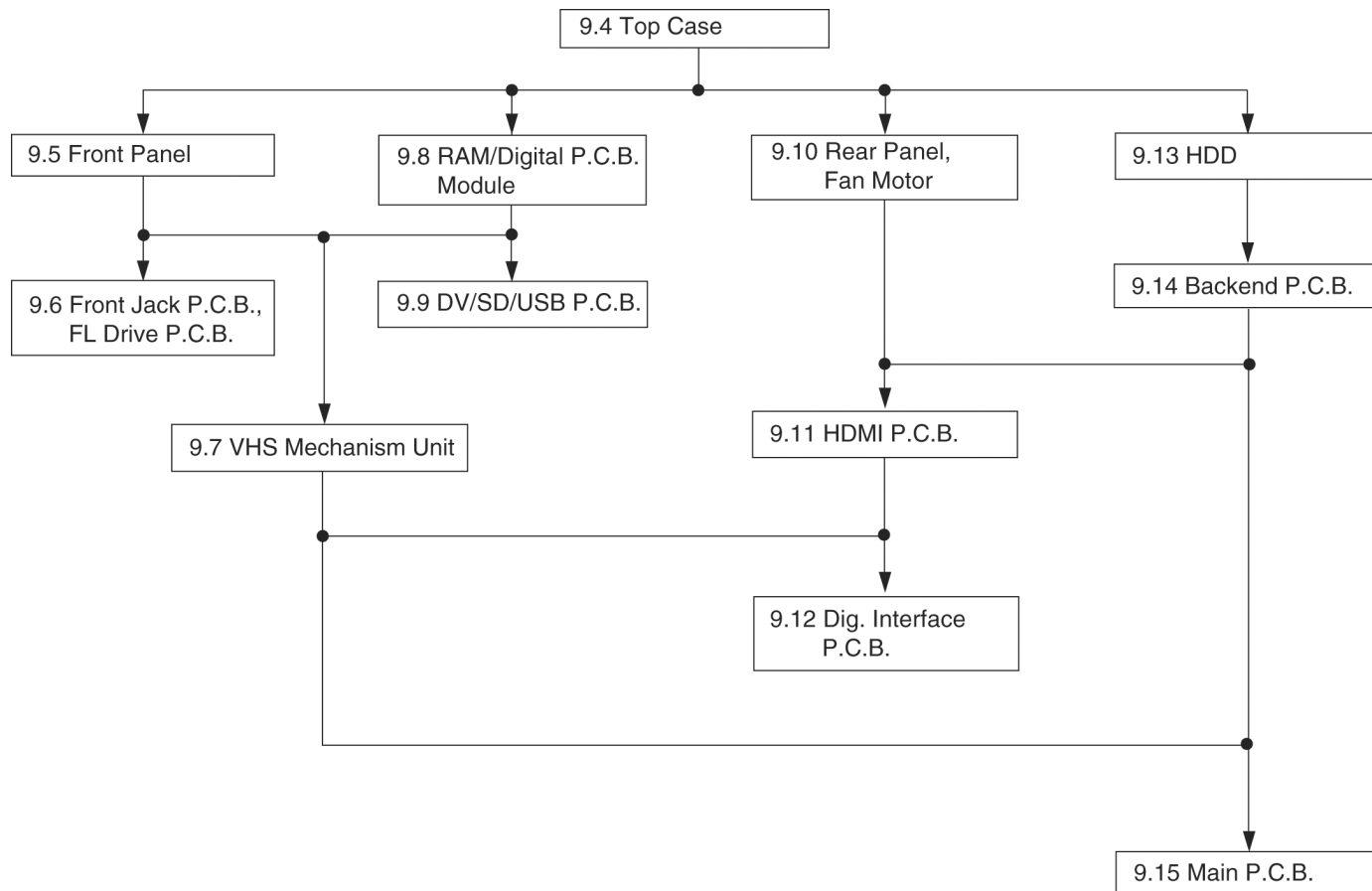

## 9.2. P.C.B. Positions

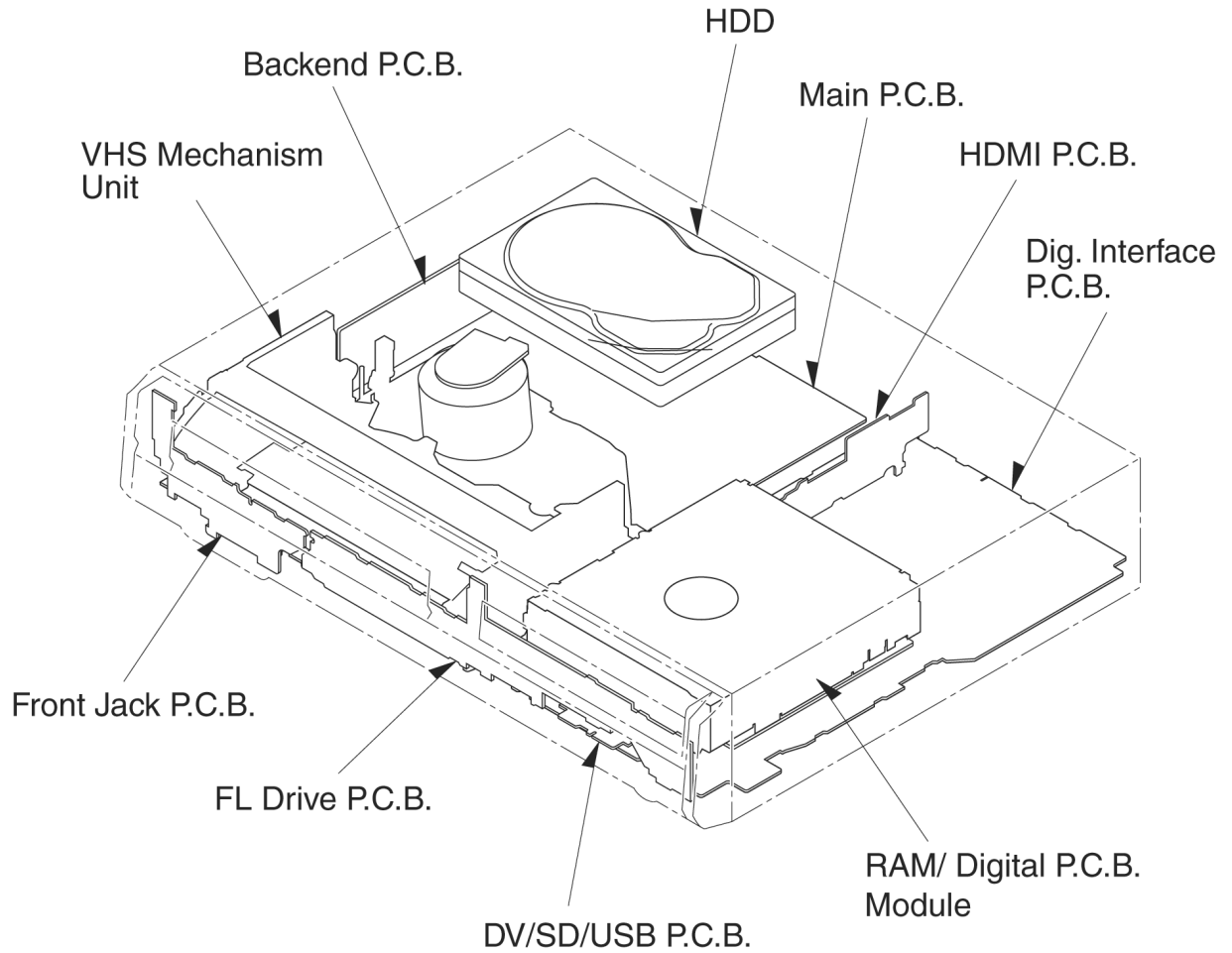

### 9.3. Caution with inserting cassette tape when disassembling the unit

**Note1:**

For description of the disassembling procedure, see the section 9.4.

**Note2:**

Video Cassette might not enter when a strong lighting is applied to VHS Mechanism when Video Cassette is inserted. Please weaken the lighting or cover with the top panel etc.

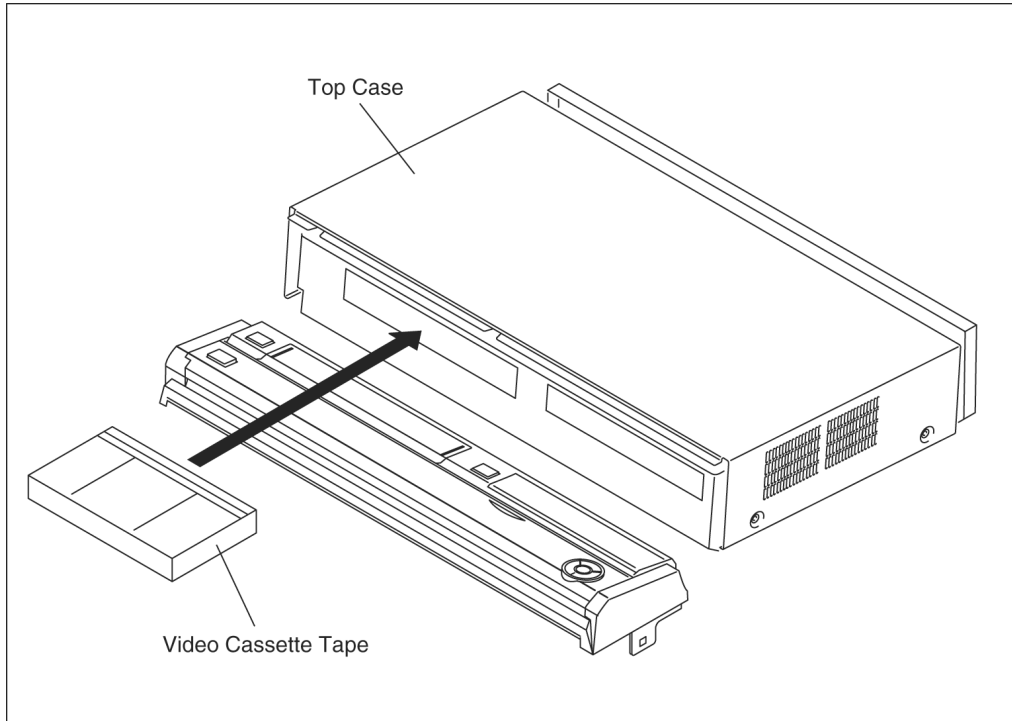

## 9.4. Top Case

1. Remove 4 Screws (A) and 3 Screws (B).
2. Slide Top Case rearward and open the both ends at rear side of the Top Case a little and lift the Top Case in the direction of the arrows.

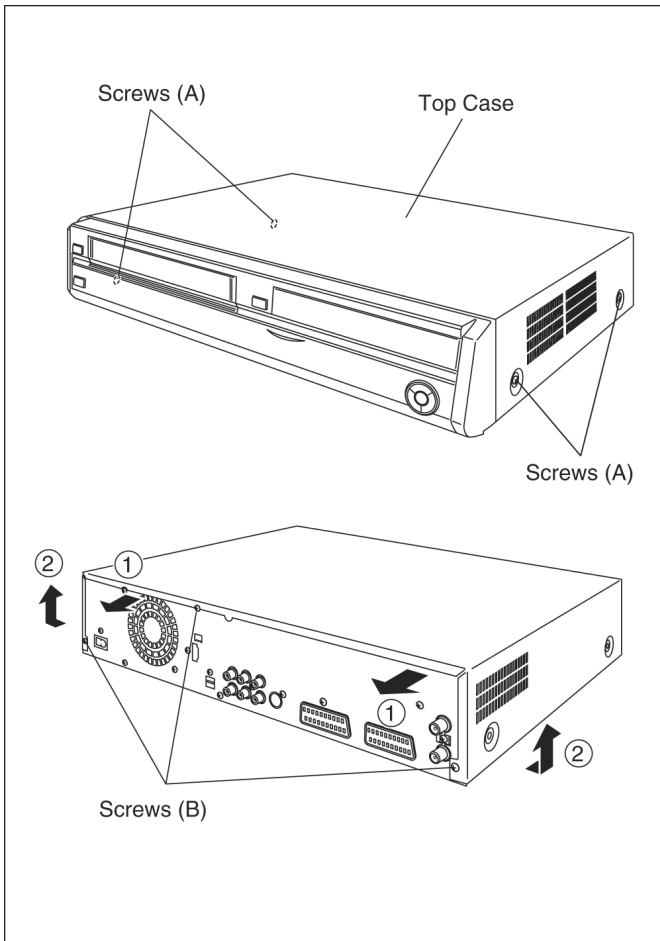

3. Make the unit turn inside out, push the tabs (E) - (H) by (-) screwdriver while pulling Front Panel in the direction of arrow.

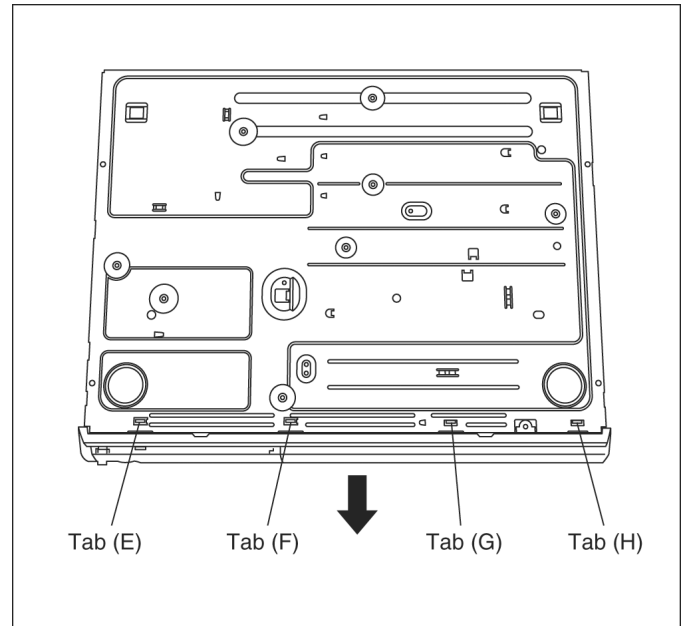

### Note:

When attaching Front Panel, in order to hook Cassette Opener Lever to Cassette Door, push up cassette door in the direction of arrow and insert a Front Panel.

## 9.5. Front Panel

1. Remove 2 Screws (A).
2. Unlock 4 tabs in (A) - (D) turn.

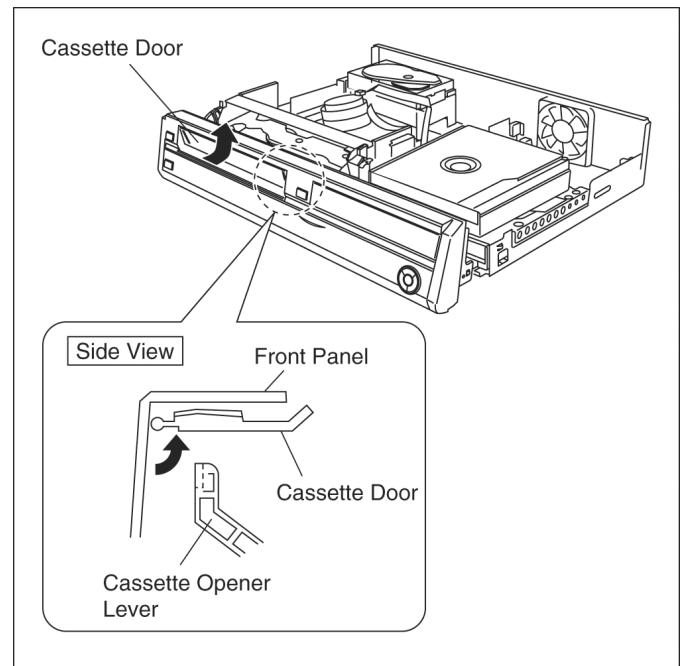
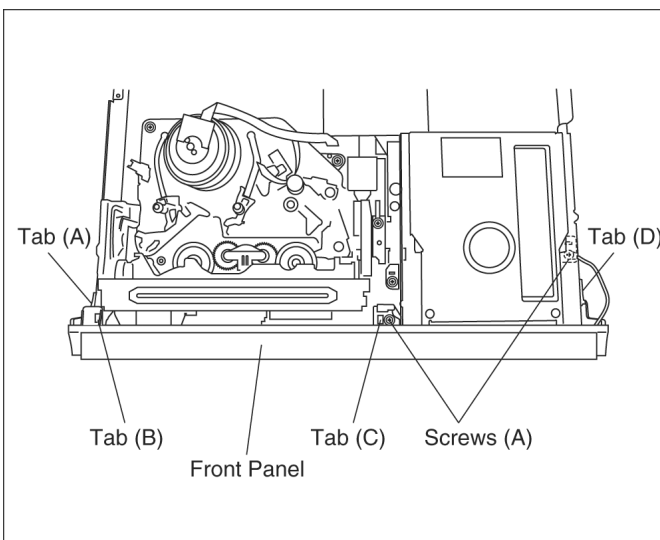

## 9.6. Front Jack P.C.B., FL Drive P.C.B.

### 9.6.1. Front Jack P.C.B.

1. Remove 3 Screws (A) and Tab to remove Front Jack P.C.B.

### 9.6.2. FL Drive P.C.B.

1. Remove 4 Screws (B) and Tab to remove FL Drive P.C.B.

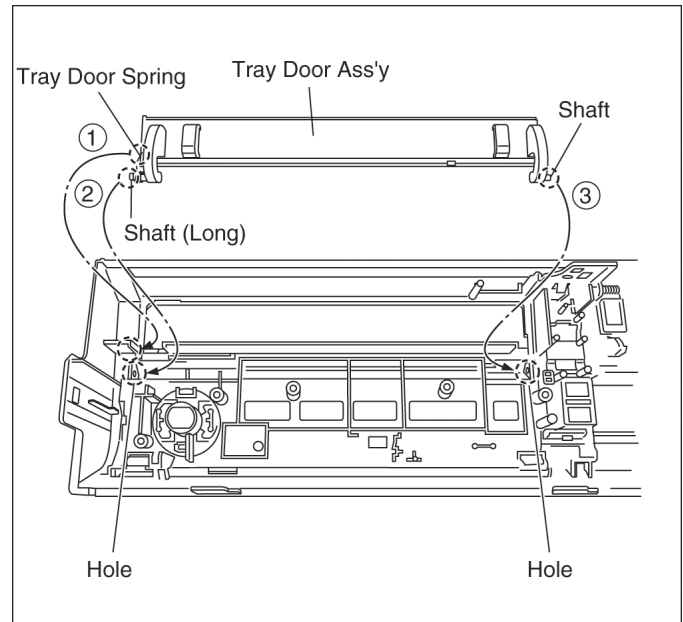
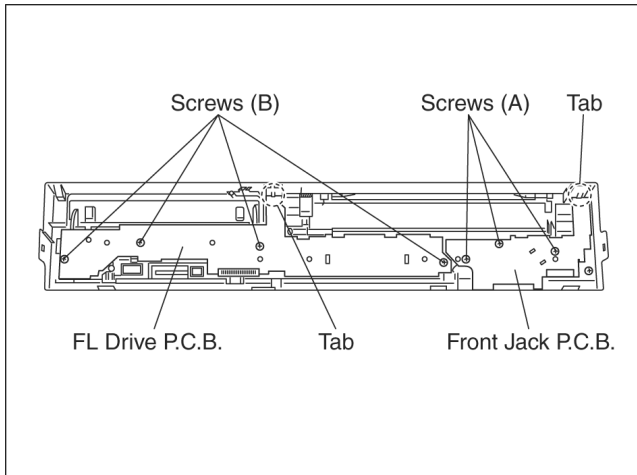

3. Confirm the Tray Door Spring is attached as following.

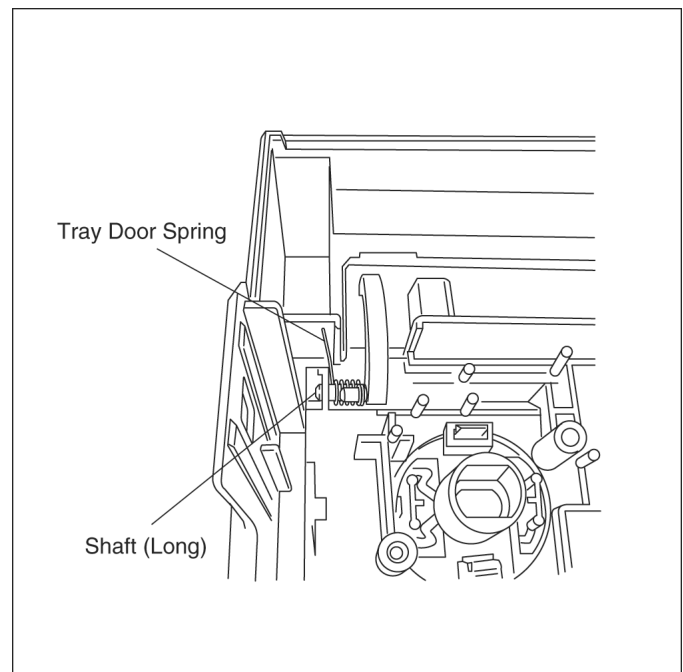

### 9.6.3. How to assemble Tray Door Ass'y

1. Attach Tray Door Spring to Tray Door Ass'y as following.

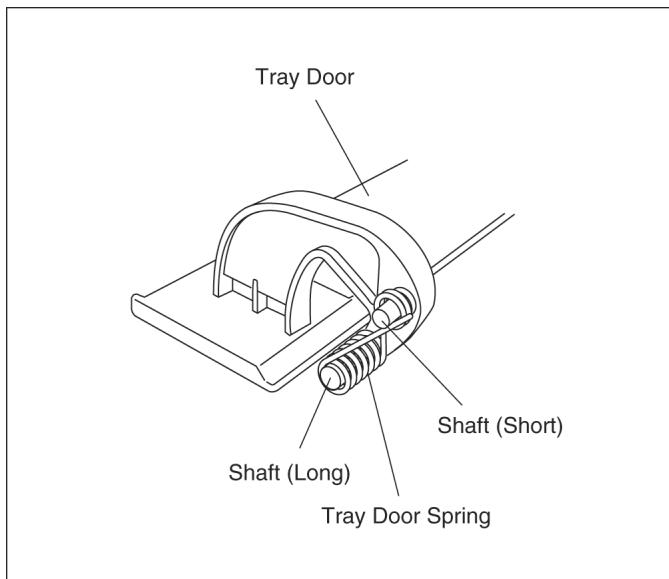

2. Attach Tray Door Ass'y in order from ① to ③.

- ①: Put the Tray Door Spring on the Front Panel.
- ②: Insert the shaft in the hole.
- ③: Insert the shaft in the hole.

### 9.6.4. Assembly of Blinder Panel and Blinder Spring

Step 1: Insert Blinder Spring into shaft of Blinder Panel.

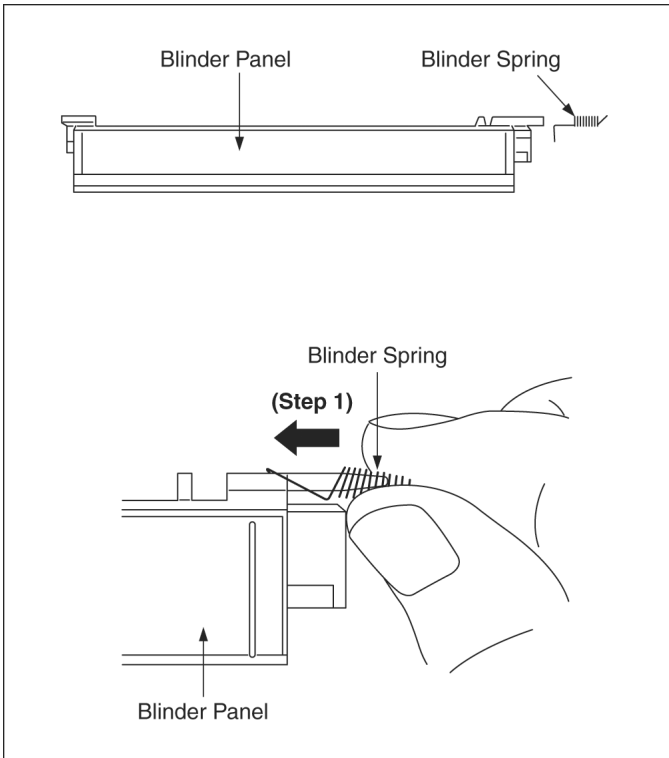

Step 2: Hook Blinder Spring to bottom of the shaft.

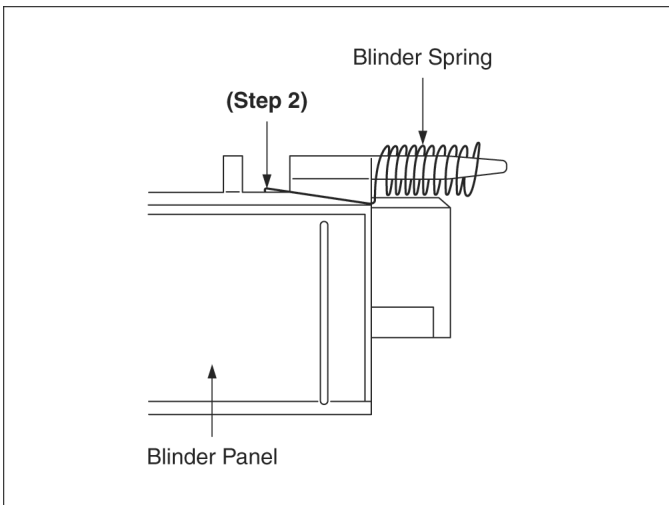

Step 3: Slide Blinder Panel into shaft hole of Front Panel.

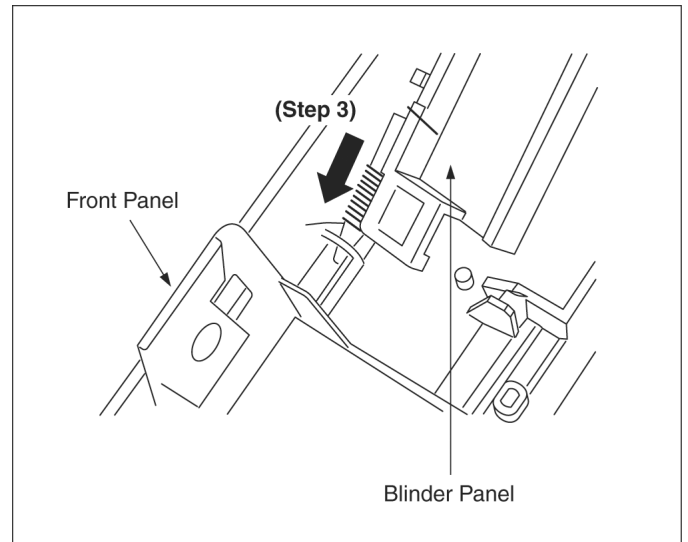

Step 4: Slide down Blinder Panel to touch the shaft on top of the rib.

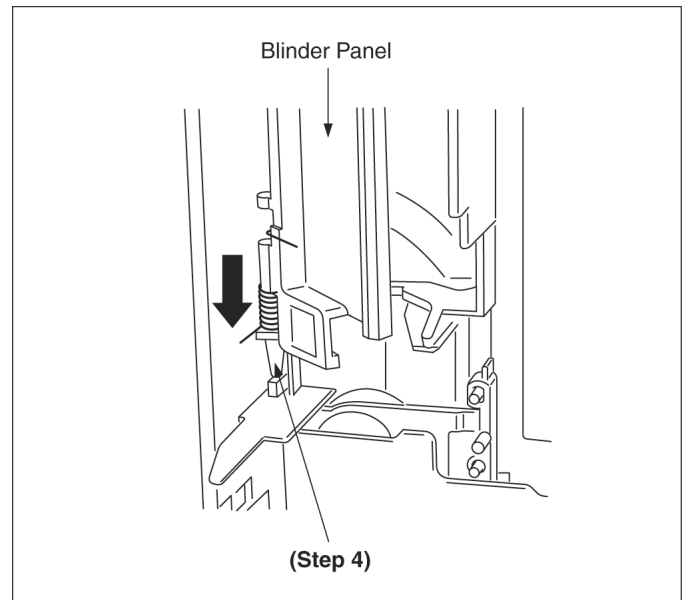

Step 5: Push shaft into shaft hole.

Step 6: Press centre of Blinder Panel and bow down.

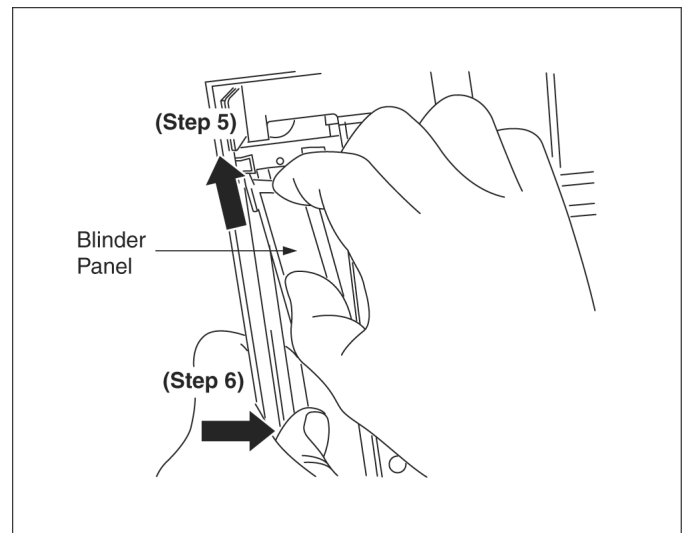

## 9.7. VHS Mechanism Unit

1. Disconnect 3 Connectors (P2501, P4002 and P6531).
2. Remove 3 Screws (A), Screw (B), Screw (C) and Screw (D).
3. Lift up VHS Mechanism Unit perpendicularly so to disconnect Connectors (P2571 and P3001).

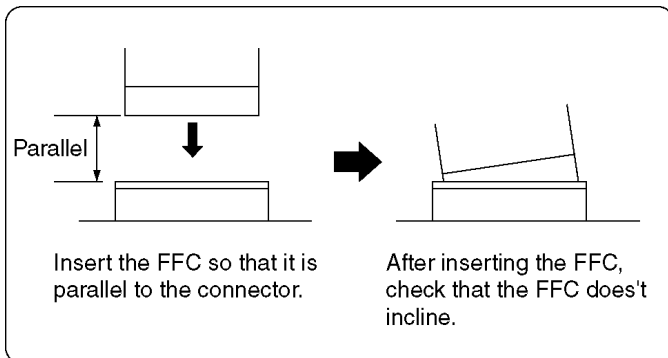
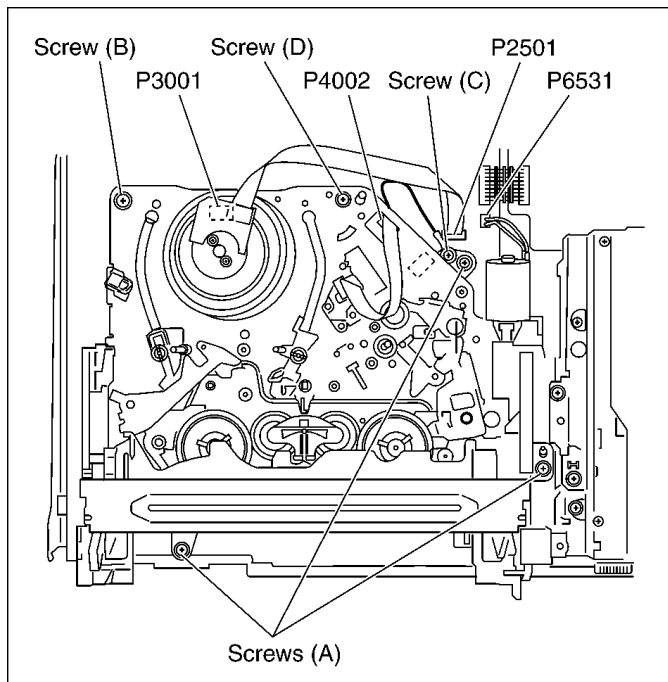

### Note:

Pay attention to stiff connections of P2571 and P4001, when removing VHS Mechanism Unit.

### 9.7.1. Caution for attaching VHS Mechanism Unit

1. Because Position SW should be set to "Eject Position", refer to Fig.(A) and set the position switch so that the boss and arrow mark come on a straight line.
2. Attach VHS Mechanism Unit so that Boss of Position SW is put into long hole of Main Cam Gear, refer to Fig. (B).

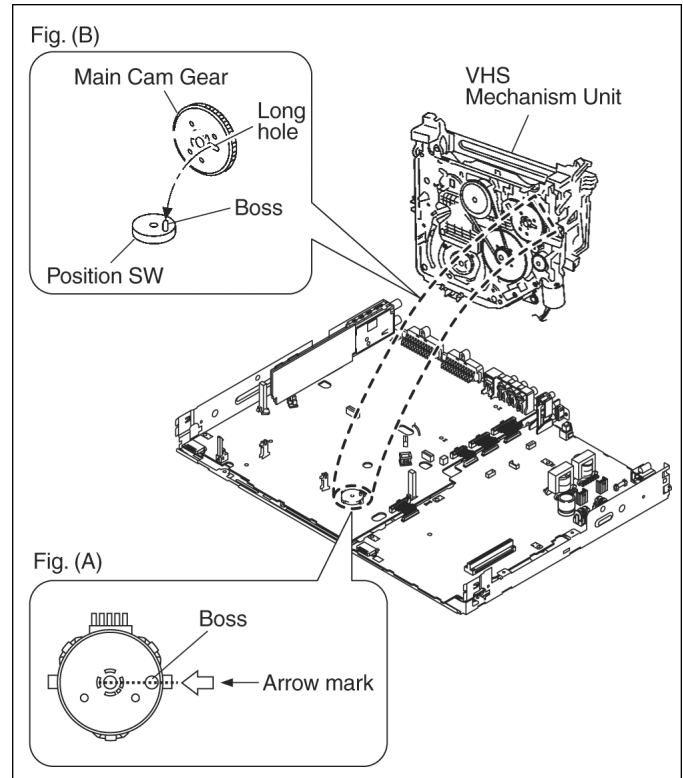

## 9.8. RAM/Digital P.C.B. Module

### Caution:

Pairing of RAM Drive and Digital P.C.B. as "RAM/Digital P.C.B. Module" have to be replaced together. If the either RAM drive or Digital P.C.B. is changed, RAM Drive unit has to be re-aligned. Because the alignment data for RAM Drive Unit is stored in Digital P.C.B..

### Note:

After replacing RAM/Digital P.C.B. Module, "TM AV1" is displayed on FL.

Once power off, and start-up again.

1. Remove the 3 Screws (A) to remove DVD Drive.

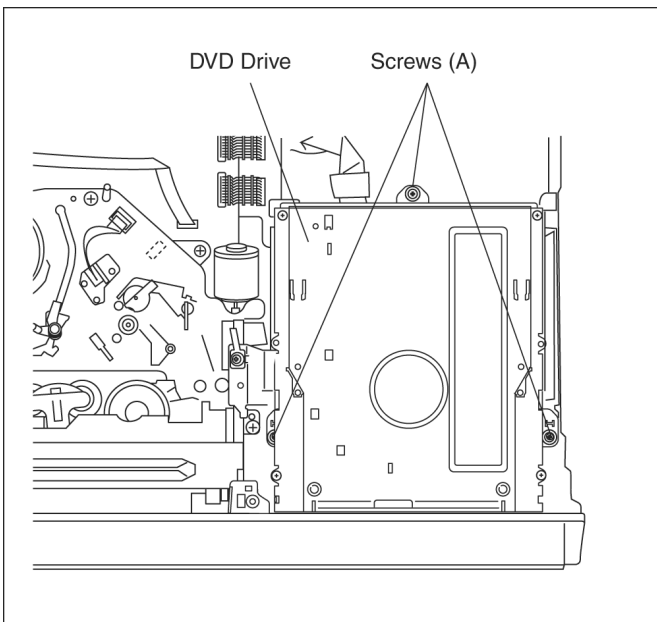

2. Remove the Digital Barrier.

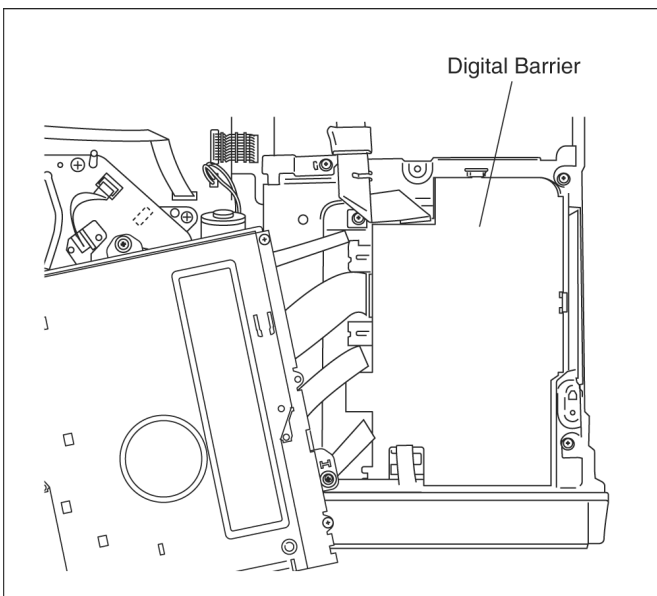

3. Remove the 2 FFCs and 3 Screws (B) to remove the Digital Shield and Digital P.C.B.

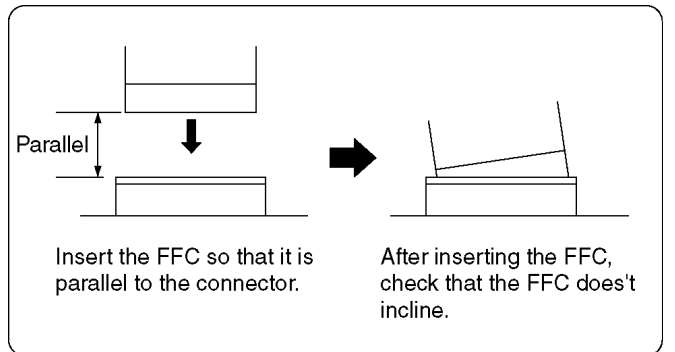
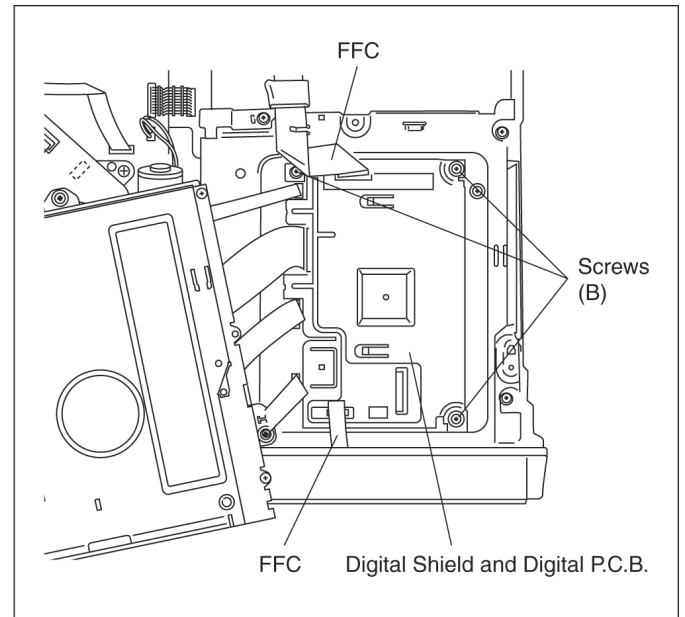

4. Put the RAM/ Digital P.C.B. Module as follow figure, remove the Digital Shield.

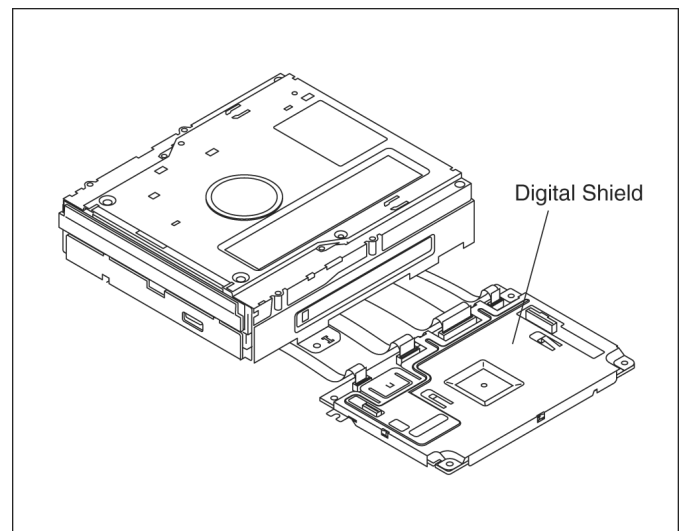

5. Put Digital P.C.B. on RAM drive and remove RAM/Digital P.C.B. Module.

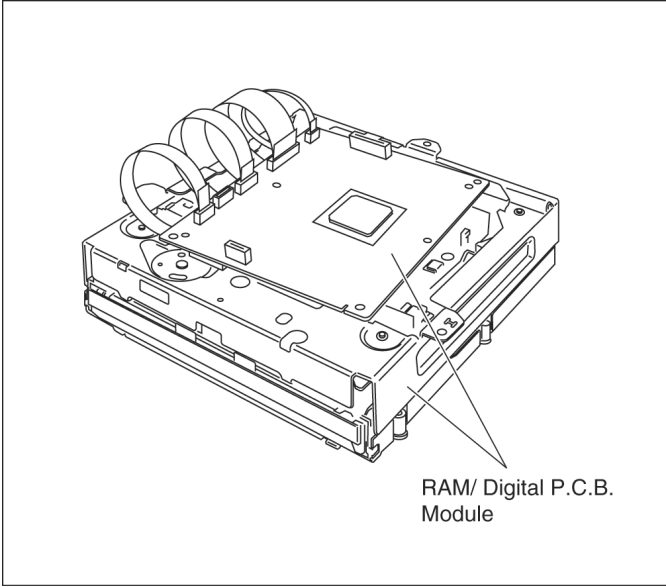

**Note:**

RAM/Digital P.C.B. Module as service part has no Digital Shield and Heat Transfer Sheet.

Before returning to customer, Digital Shield and Heat Transfer Sheet should be installed on Digital P.C.B.

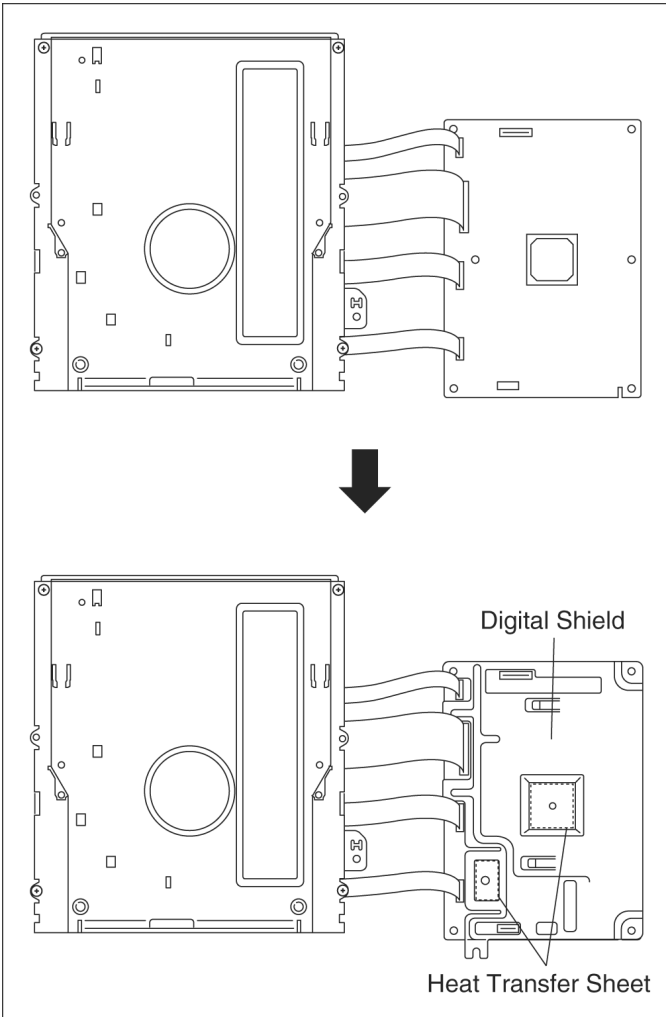

**9.9. DV/SD/USB P.C.B.**

1. Remove 2 Screws (A) to remove DV/SD/USB P.C.B.

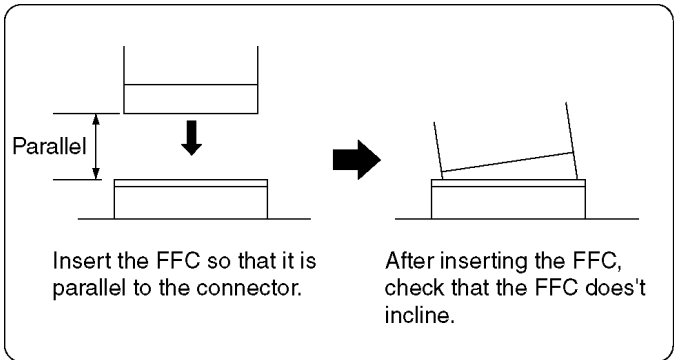
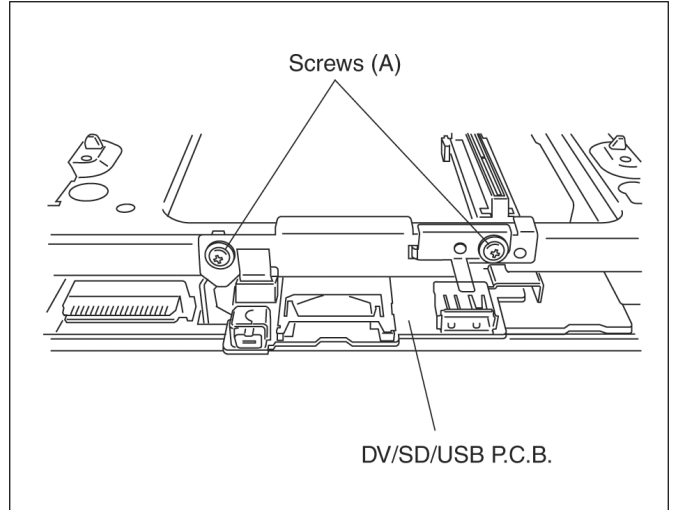

## 9.10. Rear Panel, Fan Motor

### 9.10.1. Only Fan Motor

1. Disconnect Fan Connector.
2. Remove 2 Screws (A) to remove Fan Motor.

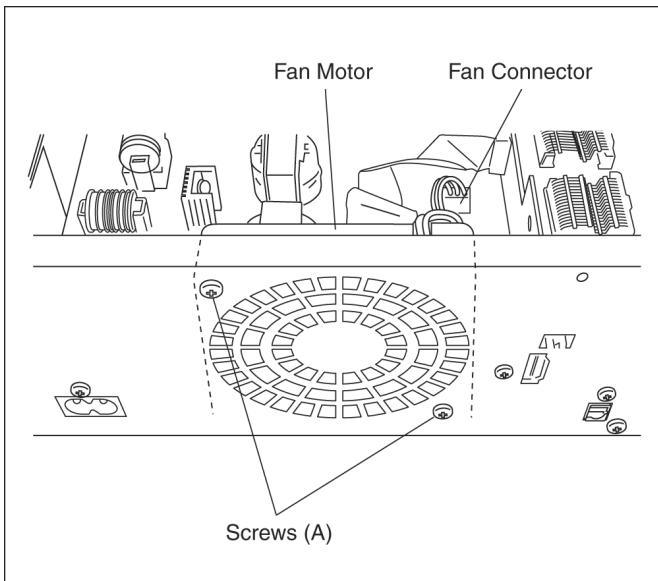

### 9.10.2. Rear Panel with Fan Motor

1. Disconnect Fan Connector.
2. Remove 8 Screws (B) and 2 Screws (C).
3. Unlock 2 Locking Tabs to remove Rear Panel with Fan Motor.

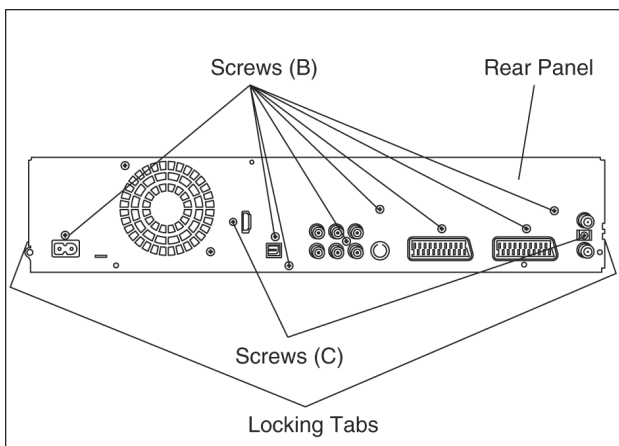

## 9.11. HDMI P.C.B.

1. Remove the Screw (A) to remove the PCB Angle.

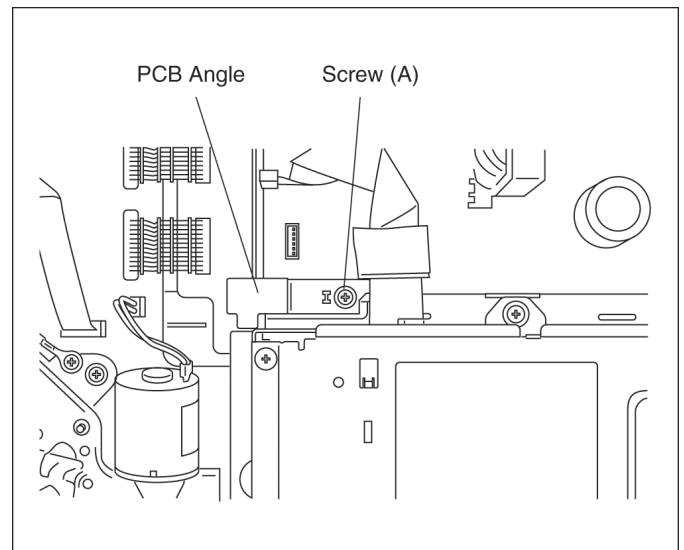

2. Peel off the Himeron Sheet and disconnect the FFC, pull out the HDMI P.C.B. in the direction of arrow.

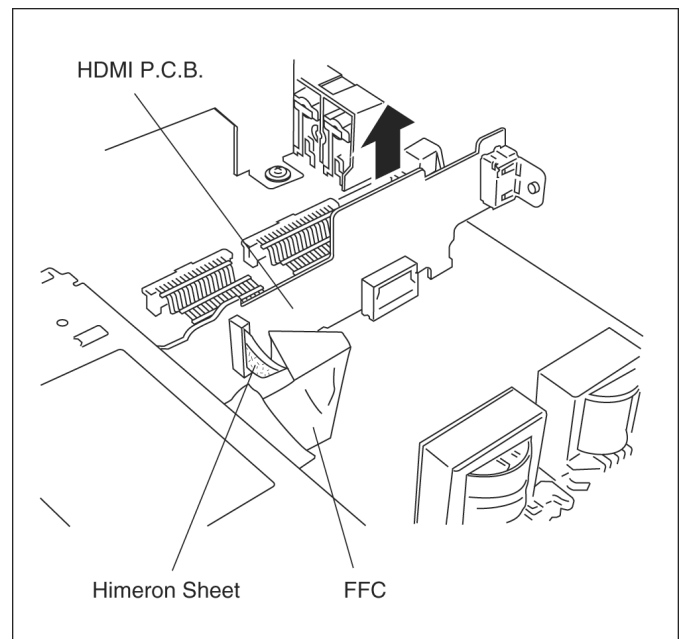

## 9.12. Dig. Interface P.C.B.

1. Remove 4 Screws (A) to remove DVD Angle.

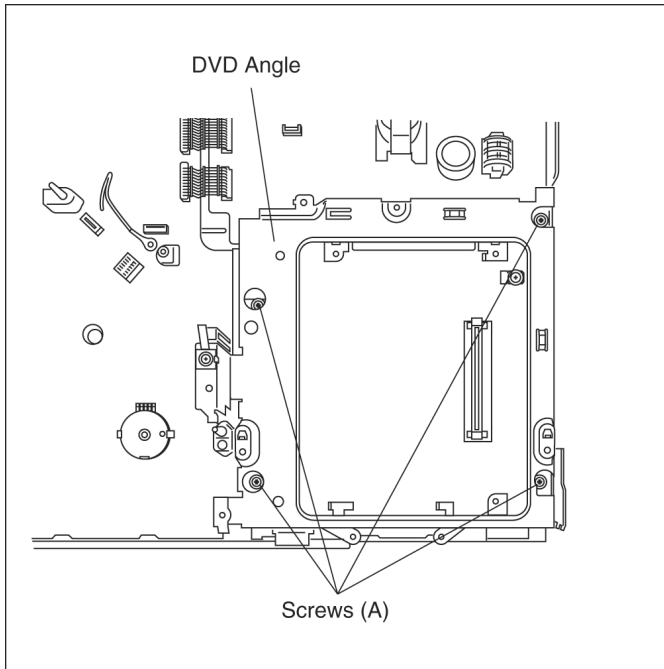

2. Disconnect 4 Connectors and remove 2 Screws (B) to remove the Dig. Interface P.C.B.

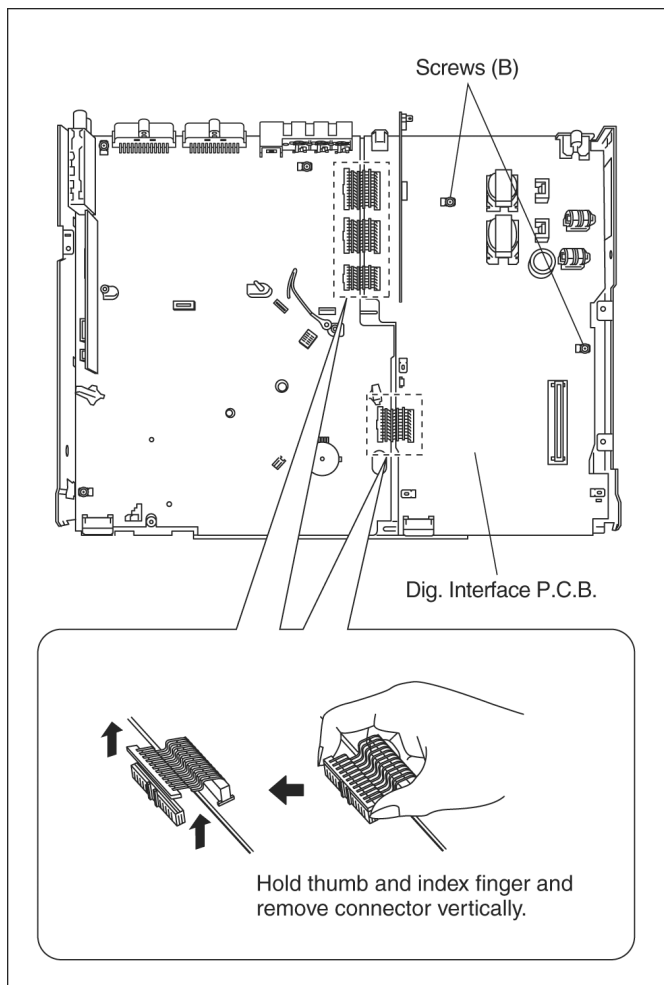

## 9.13. HDD

### Caution:

Writing the main firmware to the unit is necessary after replacing the HDD.  
Prepare the latest firmware updating disc.

### Data of HDD:

Make sure to order the Part No., RFKV\*\*\*\*HDK in Replacement Parts List when replacing the HDD.

The following data has been written on RFKV\*\*\*\*HDK.

- Main Firm
- CD DB Data
- Other Data

### Caution:

No use HDD (RFKV\*\*\*\*HDK) of the capacity of the other model use.

When replacing Dig. Interface P.C.B. or EEPROM, "UNFORMAT" indication is displayed and HDD must be formatted.

When replacing with HDD, it is necessary to update the firmware.

Please prepare the update disc.

(After that, FORMAT is necessary)

### Handling of HDD

The following precautions should be taken when handling HDD.

- a. Never give an impact to HDD. (Even a drop from 1cm height can be a cause of HDD failure.)
- b. When placing HDD on a workbench, provide a mat on a bench for shock absorption and anti-static purposes.
- c. When installing HDD, release it from your hands only after confirming that it is fully set on the chassis.
- d. Avoid stacking up HDD.
- e. HDD is unstable and easy to fall. Do not stand it on its side face.
- f. When handling HDD, hold its side faces to avoid static hazard.
- g. Do not place HDD on its wrapping bag after removal. (Prevention of static hazard)
- h. Use a screwdriver with low impact and anti-static features.

### Note:

When replacing HDD, please make the rear jumper slave or cable select configuration.

1. Remove 2 Screws (A) on Rear Panel.

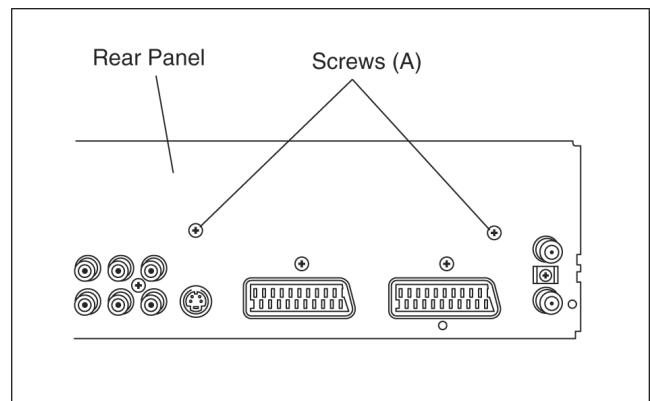

2. Remove 3 Screws (B) and disconnect FFC and Wire with Connector to remove HDD with HDD Bracket.

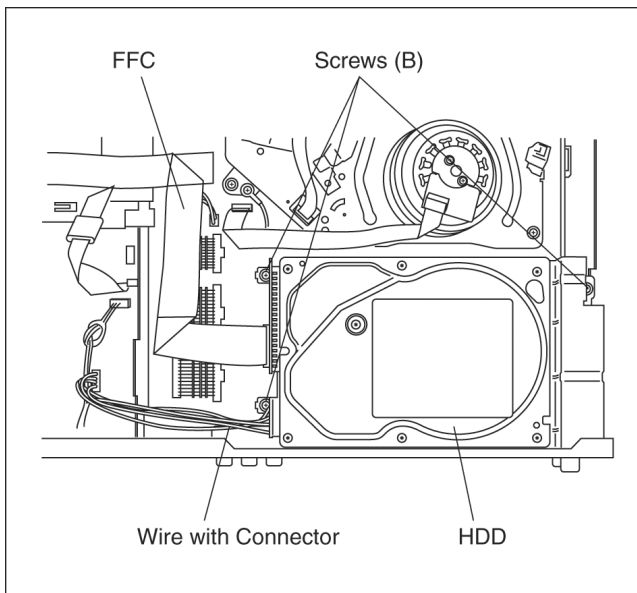

3. Put HDD up and down inversely so as not to give a shock to HDD.

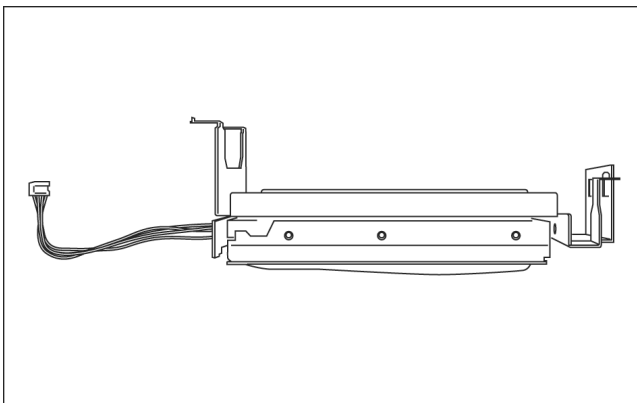

4. Remove 4 Screws (C) to remove HDD from HDD Bracket.

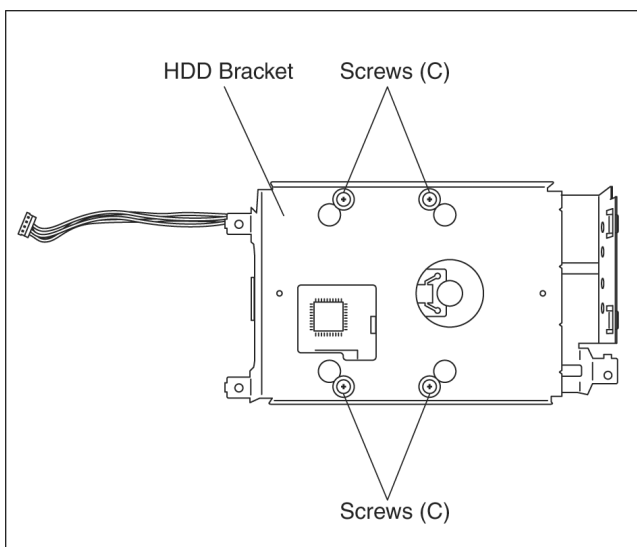

## 9.14. Backend P.C.B.

1. Pull out the Backend P.C.B. in the direction of arrows.

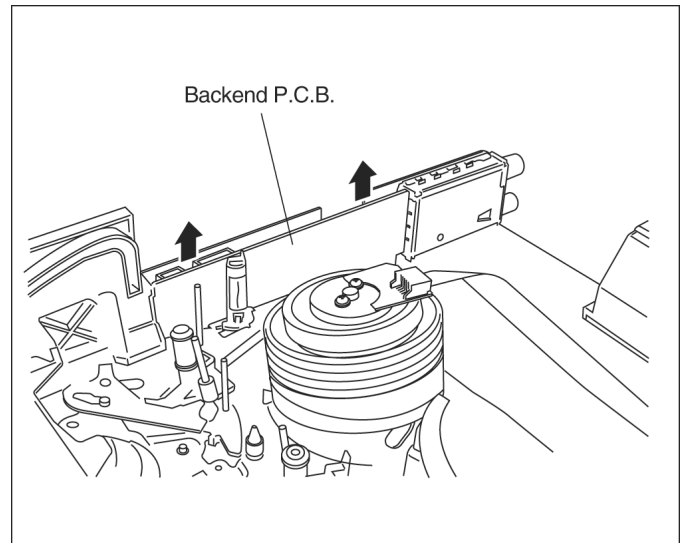

## 9.15. Main P.C.B.

1. Disconnect 4 Connectors.  
2. Remove 2 Screws (A) and remove Main P.C.B.

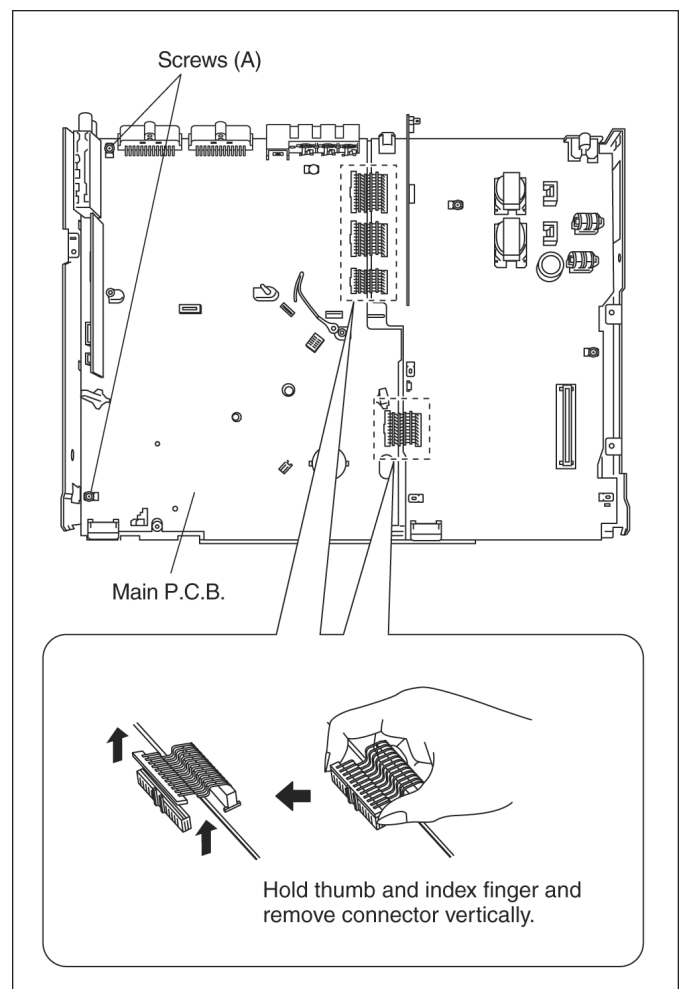

# 10 Measurements and Adjustments

## 10.1. Service Positions

### Note:

For description of the disassembling procedure, see the section 9.

### 10.1.1. Checking and Repairing of Dig. Interface P.C.B.

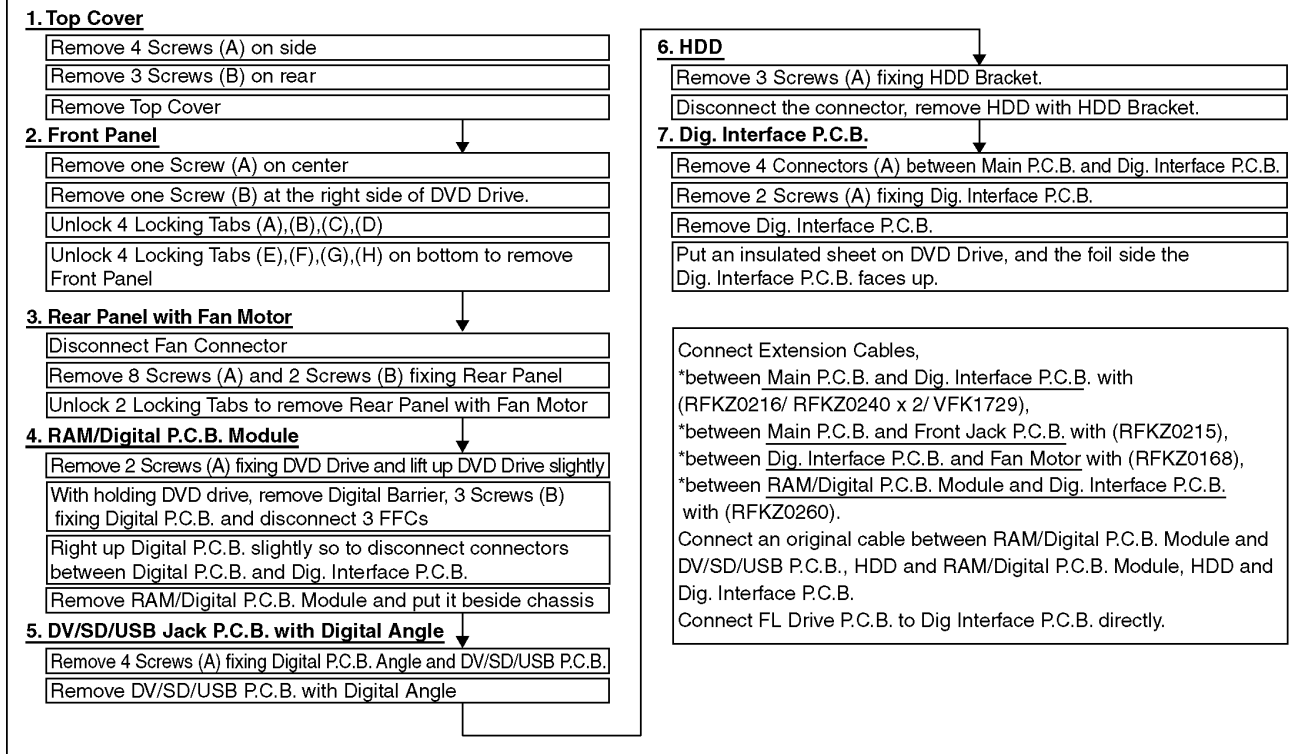

### Caution :

Red wire in the extension cable should be connected to (1) pin.

Dig. Interface P.C.B.-Fan Motor  
Extension Cable (RFKZ0168)

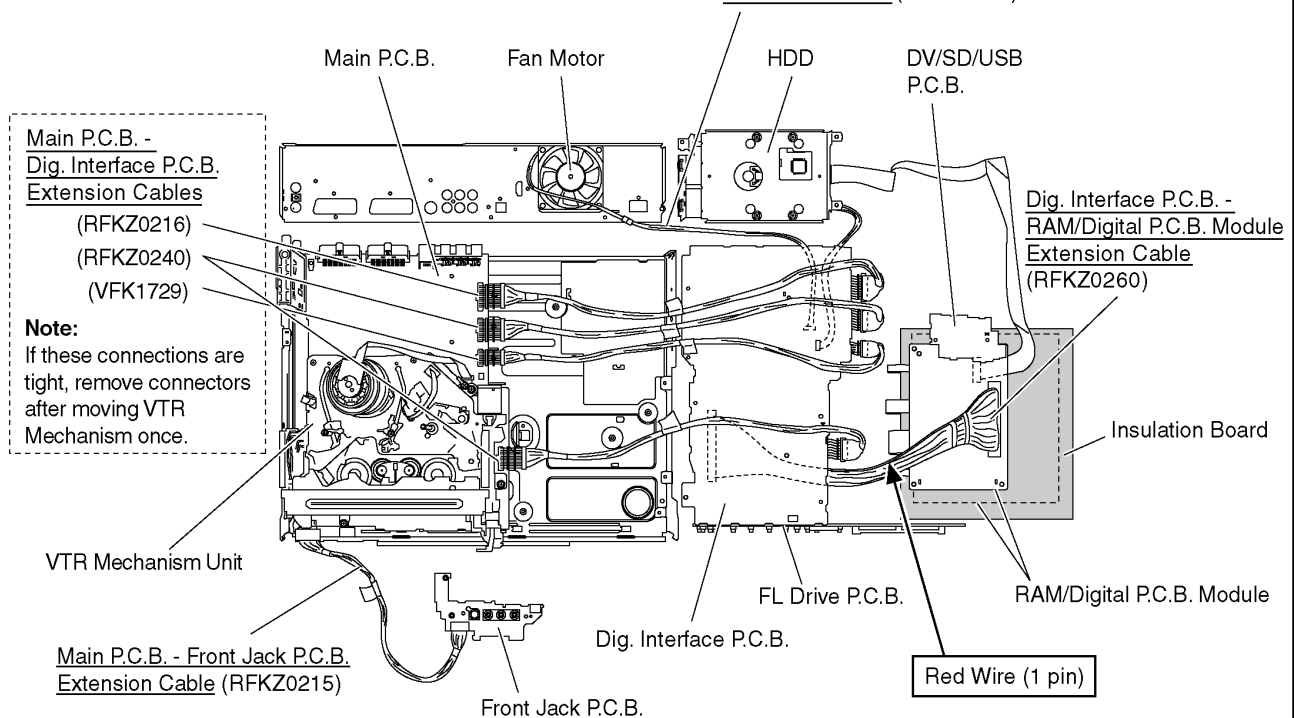

## 10.1.2. Checking and Repairing of Main P.C.B.

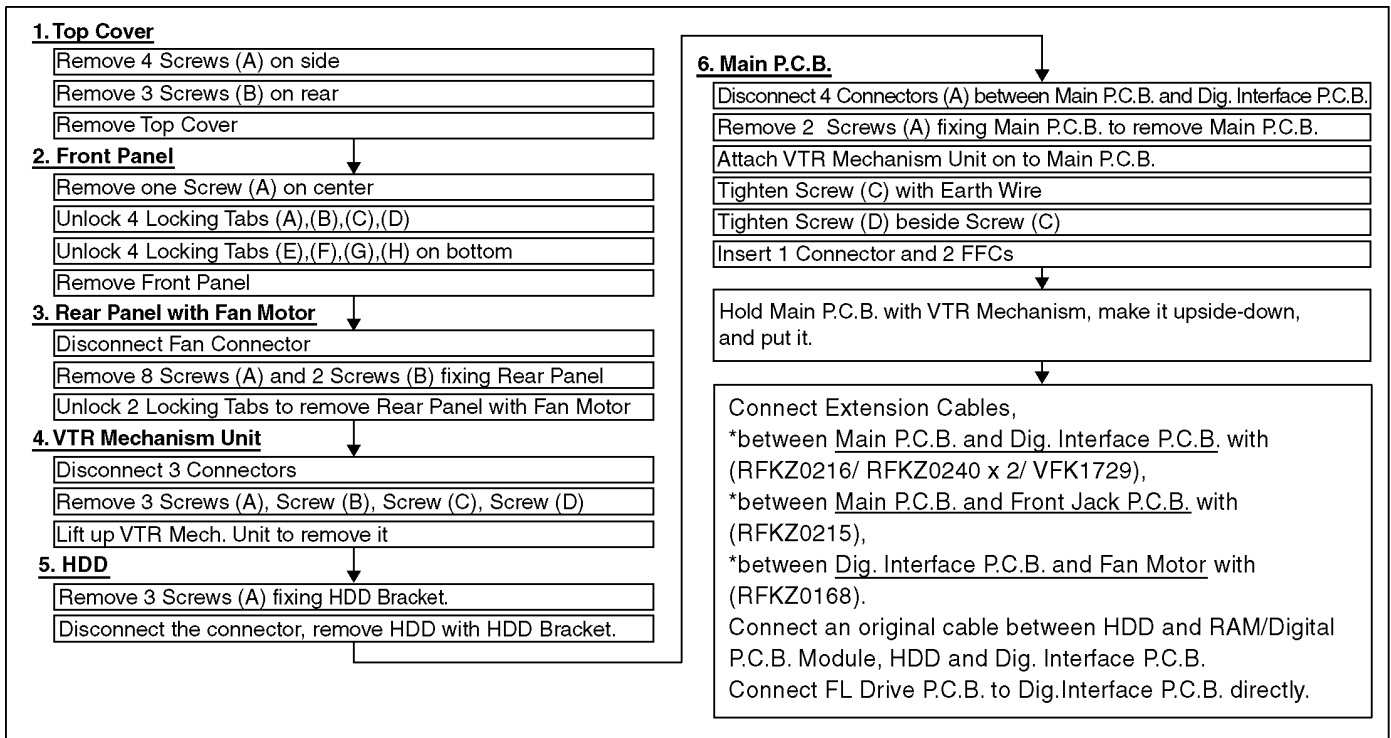

**Caution :** Red wire in the extension cable should be connected to (1) pin.

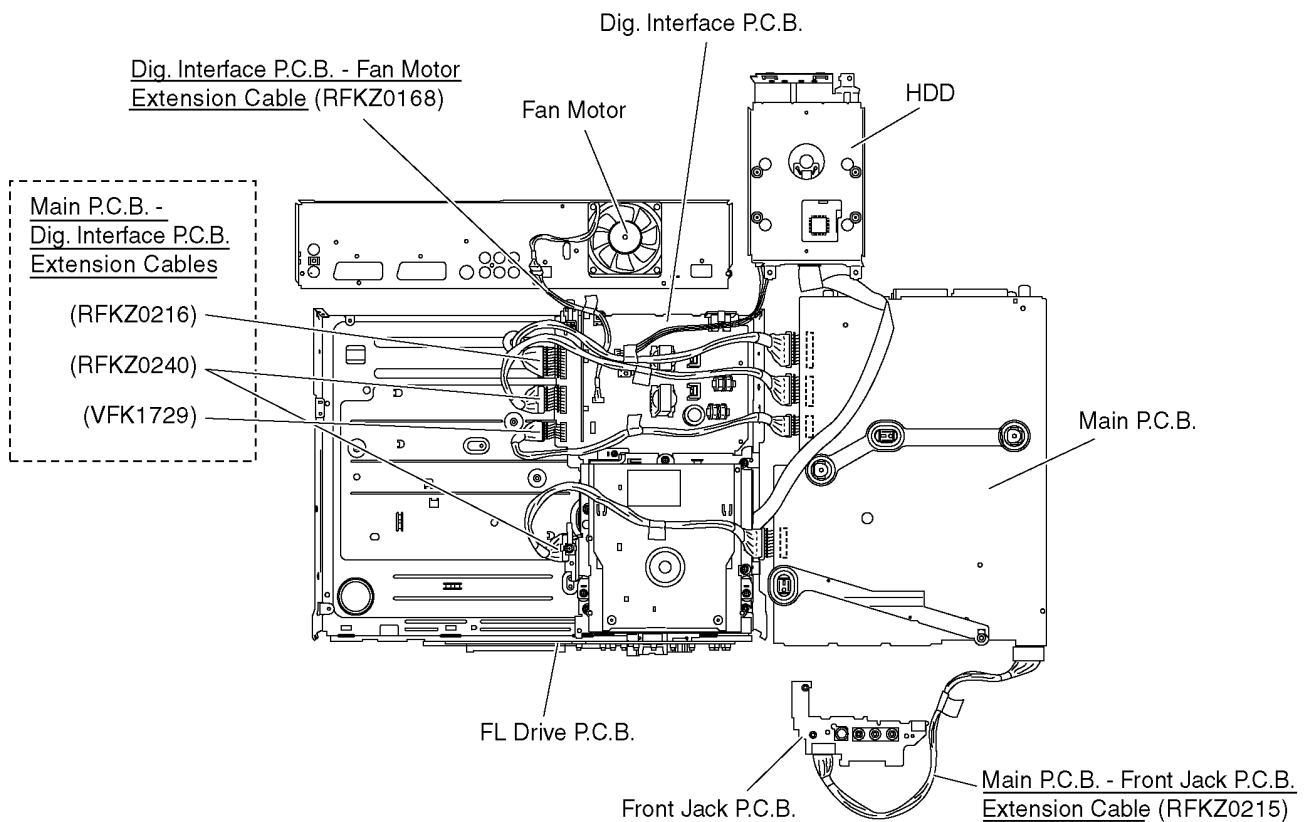

### 10.1.3. Checking and Repairing of RAM/Digital P.C.B. Module

#### 1. Top Case

Remove 4 Screws (A) on side

Remove 3 Screws (B) on rear

Remove Top Case

#### 2. RAM/Digital P.C.B. Module

Remove 3 Screws (A) fixing DVD Drive and lift up DVD Drive slightly

With holding DVD drive, remove Digital Barrier, 3 Screws (B) fixing Digital P.C.B. and disconnect 3 FFCs

Right up Digital P.C.B. slightly so to disconnect connectors between Digital P.C.B. and Dig. Interface P.C.B.

Remove RAM/Digital P.C.B. Module and put it beside chassis

Put Insulation Board on DVD Drive, then place Digital P.C.B. on Insulation Board.

Connect Extension Cable,  
\*between RAM/Digital P.C.B. Module and Dig. Interface P.C.B.  
with (RFKZ0260).  
Connect original FFC between Digital P.C.B. and HDD.

**Caution :** Red wire in the extension cable should be connected to (1) pin.

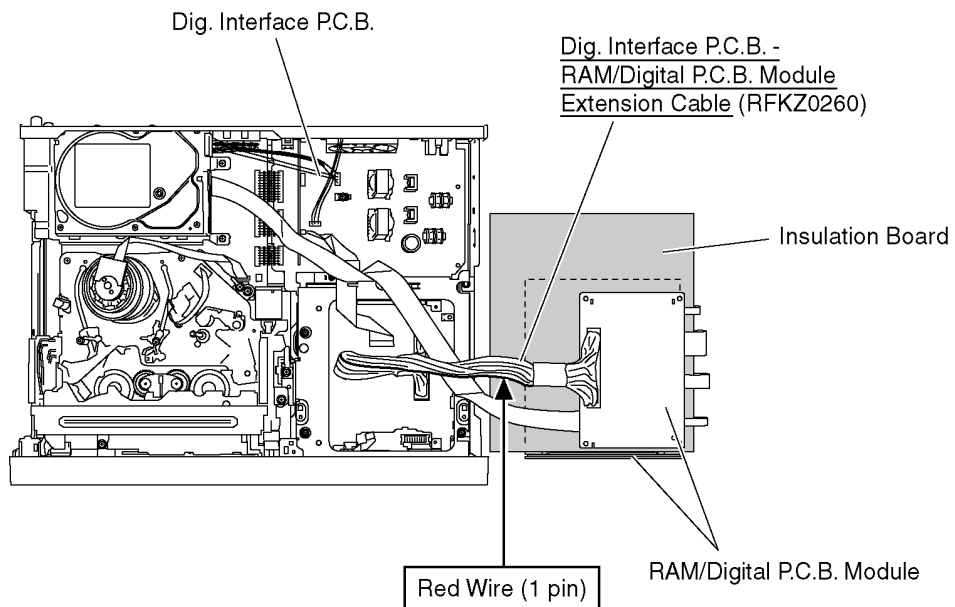

### 10.1.4. Checking and Repairing of HDD

<p><b>1. Top Case</b></p> <p>Remove 4 Screws (A) on side</p> <p>Remove 3 Screws (B) on rear</p> <p>Remove Top Case</p> <p><b>2. HDD</b></p> <p>Remove 2 Screws (A) from rear panel</p> <p>Remove 1 FFC from ATAPI Connector</p> <p>Remove 4 Pin Power Cable from Dig. Interface P.C.B.</p> <p>Remove 3 Screws (B) to remove HDD Angle with HDD</p> <p>Connect HDD ATAPI Connector to Replacement HDD</p> <p>Connect 4 Pin Power Cable to Replacement HDD</p> <p>Put Replacement HDD on Insulation Board. Connect Extension Cables, *between Replacement HDD and Dig. Interface P.C.B. with (RFKZ0169)</p>	<p>The diagram illustrates the internal components of the device during the HDD replacement process. It shows a replacement HDD mounted on an insulation board. The HDD is connected to an ATAPI connector, which is in turn connected to the Dig. Interface P.C.B. via an extension cable (RFKZ0169). The Dig. Interface P.C.B. is also connected to the RAM/Digital P.C.B. Module. The diagram is labeled with the following components:</p> <ul style="list-style-type: none"> <li>HDD - Dig. Interface P.C.B. Extension Cable (RFKZ0169)</li> <li>Dig. Interface P.C.B.</li> <li>Replacement HDD</li> <li>Insulation Board</li> <li>ATAPI Connector</li> <li>RAM/Digital P.C.B. Module</li> </ul>
---	---

## 10.2. Caution for Replacing Parts

### 10.2.1. Notice after replacing RAM/Digital P.C.B. Module

[TM AV1] is displayed, after replacing Digital P.C.B. or RAM/Digital P.C.B. Module.

Once power off, and start up again.

### 10.2.2. Items that should be done after replacing parts

✓: Necessary

—: Unnecessary

	Reset IC6001 * Note 1	Reset IC9701 * Note 1	Obtain and register a new registration code * Note 2	Main Firm update * Note 3	PG Shifter Automatic Adjustment * Note 4	X-VALUE & LINEARITY (P2 and P3 Posts) Adjustment * Note 5	HDD Format
DC Cylinder	—	—	—	—	✓	✓	—
Main P.C.B.	✓	—	—	—	—	—	—
IC6001	✓	—	—	—	—	—	—
IC9701	—	✓	—	—	—	—	—
Dig. Interface P.C.B.	—	✓	✓	—	✓	—	✓
IC9705 (EEPROM)	—	—	✓	—	✓	—	✓
HDD	—	—	—	✓	—	—	✓

**\* Note1:**

Resetting object	Condition of power	Short Terminal
IC6001	POWER ON	TL6004 (Reset L) and TL6002 (GND)
IC9701	POWER ON	IC9706-4 (Reset L) and GND

**\*Note2:**

Please will always pass the customer "Warning for Customers Who Use the DivX Video-on-Demand content." with the product and get it when you unavoidably exchange EEPROM or P.C.B. including EEPROM (When the product is exchanged, it is the same.).

You must use print attached to service part (EEPROM or P.C.B. including EEPROM) or must use copy of print below as "Warning for Customers who use the DivX Video-on-Demand content."

Information needed without fail for the customer for whom it is used continuing DivX Video-on-Demand Service to "Manual for the customer" is recorded.

## Appendix:

- \* Parts that memorize user's information are only EEPROM(RFKFXXXXXX).
- \* The registration of Registration Code is possible for half a year up to 6 recorders up to 10 recorders a year. Replacement of EEPROM or P.C.B. including EEPROM spends one of this.

Registration Code is memorized in EEPROM.

Model without VHS: Main P.C.B.

Model with VHS: Dig. Interface P.C.B. (Power & DVD I/F P.C.B.)

If exchange above P.C.B. or EEPROM, new registration Code differ from previous Registration Code will be generated. In this case if your customer uses DivX Video-on-Demand service, he/she will no longer be able to play any content that he/she purchased under that same registration code.

Therefore your customer will need to obtain and register the new registration code.

\*Copy this page and cut on the dotted line and give the lower half to your customer.

---

### Warning for Customers who use the DivX Video-on-Demand content.

1. The registration code has been changed for the repair of the product or the product exchange.
2. Obtain and register a new registration code, otherwise you will no longer be able to play DivX Video-on-Demand content.
3. Follow the procedure on the DivX Video-on-Demand web site to register at

<http://vod.divx.com/>

\* If you do not use the DivX Video-on-Demand content, please ignore this warning.

**Note3:**

Please prepare latest firmware updating disc.

\* Main Firm is being recorded in HDD, but new HDD has no data.

Writing Procedure of Main Firm:

<<Caution>>

- (1) Writing of Main Firm needs 3, 4 minutes.
  - (2) Never cut the power of DVD Recorder until writing in Firmware ends.
  - (3) Initial settings and contents of reservation will not change if writing is normally completed.
    1. Prepare updating disc for firm ware.
    2. Replace HDD.
    3. Turn on power of DVD Recorder.
    4. After [PLEASE WAIT] is displayed on FL., [HDD ERR] is displayed on FL.
    5. Tray opens automatically.
    6. Insert updating disc for Firmware and press OPEN/CLOSE key. (If a wrong disc was inserted, [NG DISK] [NO FVU] is displayed on FL.)
    7. [LOAD] → [LD FVU] ↔ [M\_FIRM] are displayed on FL alternately.
    8. [MAIN] ↔ [UPD OK] blink alternately and Tray opens. Take out disc (Writing was finished).
    9. Press Power button to turn off power.
    10. Press Power button to turn on power.
    11. [HELLO] → [SELF CHECK] are displayed on FL.
    12. [UNFORMAT] is displayed on FL.
    13. After [UNFORMAT] was displayed, message to request FORMAT is displayed on TV screen.
    14. Select [Yes] and press [ENTER] key to format HDD.
- (After FORMAT, program in HDD will be lost, but Main firm will not be lost.  
 "Write of the main farm" is completed above.

\* Drive firm is not updated by above operation. If you wish update Drive firm, please prepare the disc for latest firmware update, and write it again.

\* If the version of the firm you have prepared was same as or later than that has already been written in deck, 'UNSUPPORT' is displayed on FL.

\* In a usual updating of firmware, writing is not performed when the timer reservation standby was not released.

**\*Note4:**

## PG Shifter Automatic Adjustment Procedure

PROCEDURE		F.I.P. DISPLAY	
Turn on the Service Mode. 1. Set Drive Select to VHS and press the [STOP] and [EJECT] key simultaneously for more than 3 seconds.		00000	
Activate the Service Mode 2. (Auto tracking will be turned off) 2. Press the [STOP] and [EJECT] key simultaneously twice.		20000	
Put it in PG adjustment mode. 3. Press the [EJECT] key for more than 3 seconds.		2 00	
Set it adjustment No.1. 4. Press the [CH UP] key once.		2 100	
Insert the alignment cassette tape (VFM8125H3F). 5. The PG Shifter Adjustment starts automatically.		2 100	
6. This value displays that PG Adjustment data is memorized in EEPROM.		For example: 0 557	
Result	Success	Cassette tape is ejected automatically.	2 100
	Error	NG1 in the PG Shifter Automatic Adjustment (The cylinder rotation is unstable during the automatic adjustment.)	F20
		NG2 in the PG Shifter Automatic Adjustment (The vertical sync signal is lacked while over 5 seconds on the alignment tape.)	F21
		NG3 in the PG Shifter Automatic Adjustment (The installing position of Heads to the cylinder is out of specification.)	F22
		NG4 in the PG Shifter Automatic Adjustment (The servo is not locked to the cylinder for more than 10 sec.)	F23
Exit from Service Mode. 7. Press [STOP] and [EJECT] keys simultaneously in 6 times. * Then the FIP becomes normal indication.		10:00 (Normal Indication)	

**\*Note5:**

X-VALUE & LINEARITY (P2 and P3 Posts) Adjustment Procedure

1. Set the Auto Tracking to off.
  - (1) Set Drive Select to VHS and press the [STOP] and [EJECT] keys simultaneously for more than 3 seconds to enter Service Mode.
  - (2) Press [STOP] and [EJECT] keys simultaneously twice to activate Service Mode 2, and then Auto-Tracking is turned off.
2. Perform the X-VALUE ADJUSTMENT

X-VALUE ADJUSTMENT

1. After turning off the Auto tracking, playback the alignment Tape and press [CH UP] and [CH DOWN] keys simultaneously to adjust the tracking to FIX value.
2. Adjust A/C Head Base so that the envelope becomes maximum level. (It is described on "5-2. Tape Interchangeability Adjustment" in "R4 Mechanism" that is separated volume.)

Alignment Tape	VFM8125H3F
Test Point of Playback Envelope	TW3001 (or TW4502)

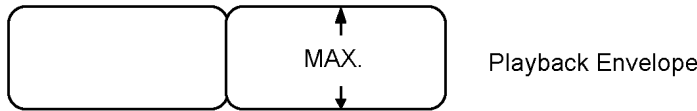

LINEARITY ADJUSTMENT

1. After turning off the Auto tracking, playback the alignment Tape and press [CH UP] and [CH DOWN] keys simultaneously to adjust the tracking to FIX value.
2. Adjust the LINEARITY so that the envelope is flat when moving tracking to (+) and (-) directions.

Alignment Tape	VFM8125H3F
Test Point of Playback Envelope	TW3001 (or TW4502)

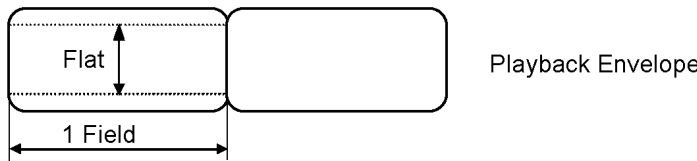

- Main symptoms and Adjustment point

Envelope	Post Name		Adjustment Method
	P2 Post		Turn P2 Post counter-clockwise (Approx. 1/2 revolution)
	P2 Post		Turn P2 Post clockwise (Approx. 1/4 revolution)
	P3 Post		Turn P3 Post clockwise (Approx. 1/2 revolution)
	P3 Post		Turn P3 Post counter-clockwise (Approx. 1/4 revolution)
	P2 Post	P3 Post	Turn P2 Post clockwise (Less than 1 revolution) Turn P3 Post counter-clockwise (Less than 1 revolution)

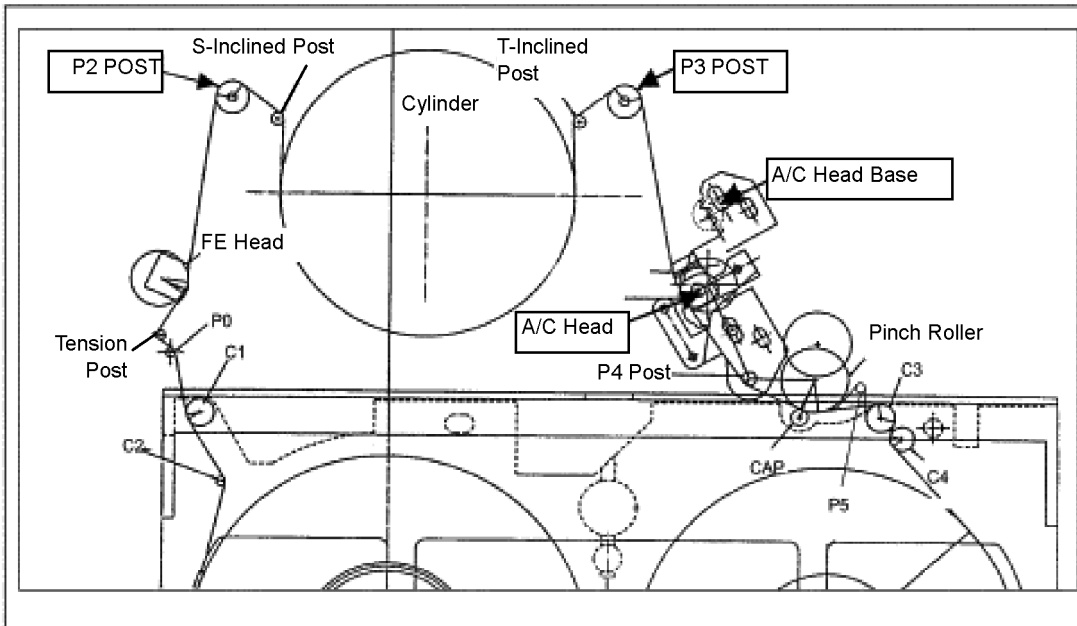

### 10.3. (DVD) Standard Inspection Specifications after Making Repairs

After making repairs, we recommend performing the following inspection, to check normal operation.

No.	Procedure	Item to Check
1	Turn on the power, and confirm items pointed out.	Items pointed out should reappear.
2	Insert RAM disc.	The Panasonic RAM disc should be recognized.
3	Enter the EE (TU IN / AV IN - AV OUT) mode.	No abnormality should be seen in the picture, sound or operation.
4	Perform auto recording and playback for one minute using the RAM disc.	No abnormality should be seen in the picture, sound or operation. *Panasonic DVD-RAM disc should be used when recording and playback.
5	Model with the HDD: Perform auto recording and playback for one minute using the HDD.	No abnormality should be seen in the picture, sound or operation.
6	If a problem is caused by a VCD, DVD-R, DVD-Video, Audio-CD, or MP3, playback the test disc.	No abnormality should be seen in the picture, sound or operation.
7	Models with SD Card Slot USB Input Jack or DV Input Jack: In case of that the trouble is caused by SD Card and/or USB terminal and/or DV terminal.	Models with SD Card or USB Input Jack or DV Input Jack; 1) SD Card: Check to be able to display and copy the picture. 2) USB terminal: Check to be able to display and copy the picture. 3) DV terminal: Check to be able to record from DVC.
8	After checking and making repairs, upgrade the firmware to the latest version.	Make sure that [FIRM_SUCCESS] appears in the FL displays. *[UNSUPPORT] display means the unit is already updated to newest same version. Then version up is not necessary.
9	Transfer [9][9] in the service mode setting, and initialize the service settings (return various settings and error information to their default values. The laser time is not included in this initialization).	Make sure that [CLR] appears in the FL display. After checking it, turn the power off.

Use the following checklist to establish the judgement criteria for the picture and sound.

Item	Contents	Check	Item	Contents	Check
Picture	Block noise		Sound	Distorted sound	
	Crosscut noise			Noise (static, background noise, etc.)	
	Dot noise			The sound level is too low.	
	Picture disruption			The sound level is too high.	
	Not bright enough			The sound level changes.	
	Too bright				
	Flickering color				
	Color fading				



# 11 Block Diagram

## 11.1. Power Supply Block Diagram

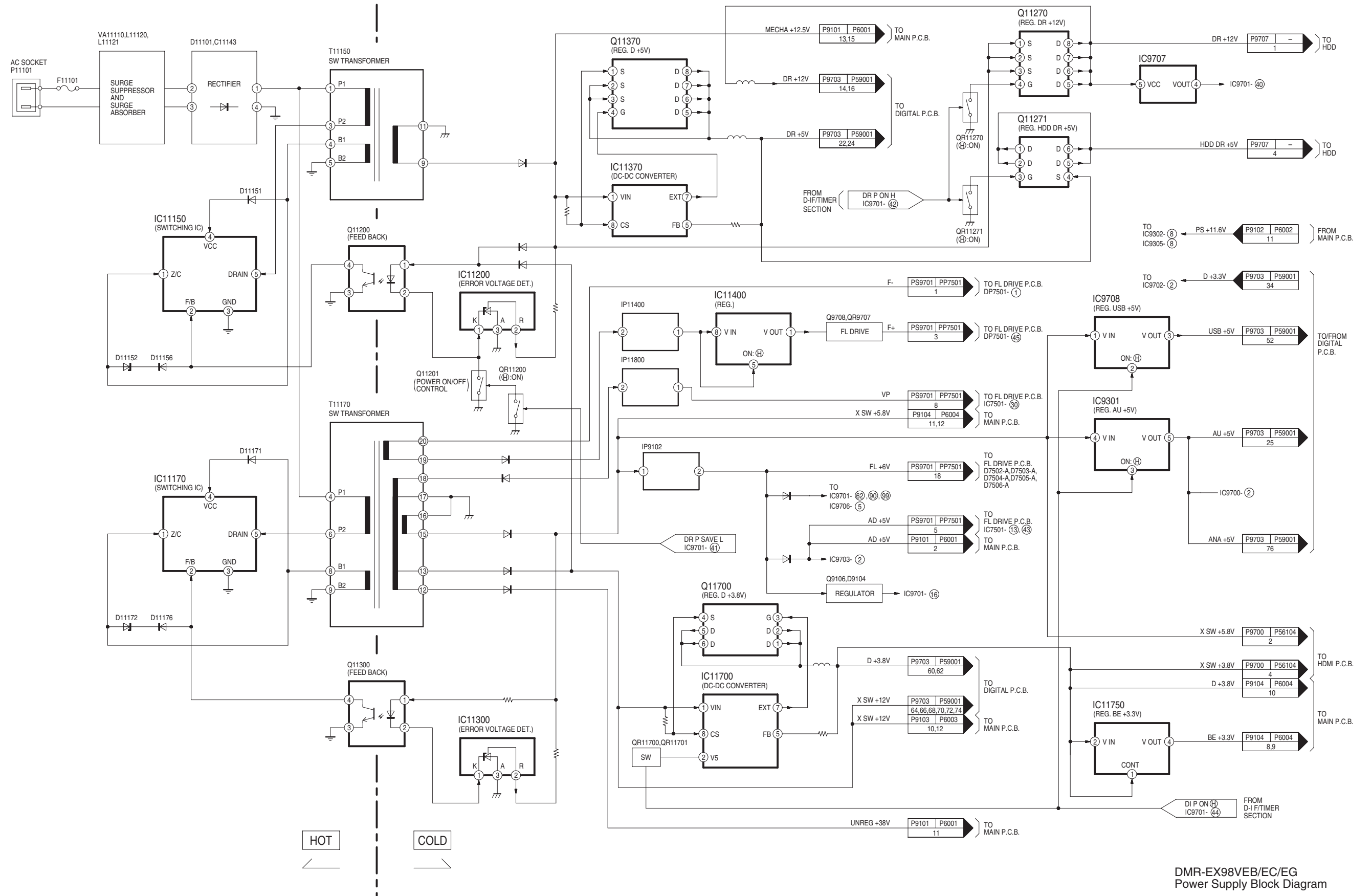

DMR-EX98VEB/EC/EG  
Power Supply Block Diagram

## 11.2. Main P.C.B. Regulator Block Diagram

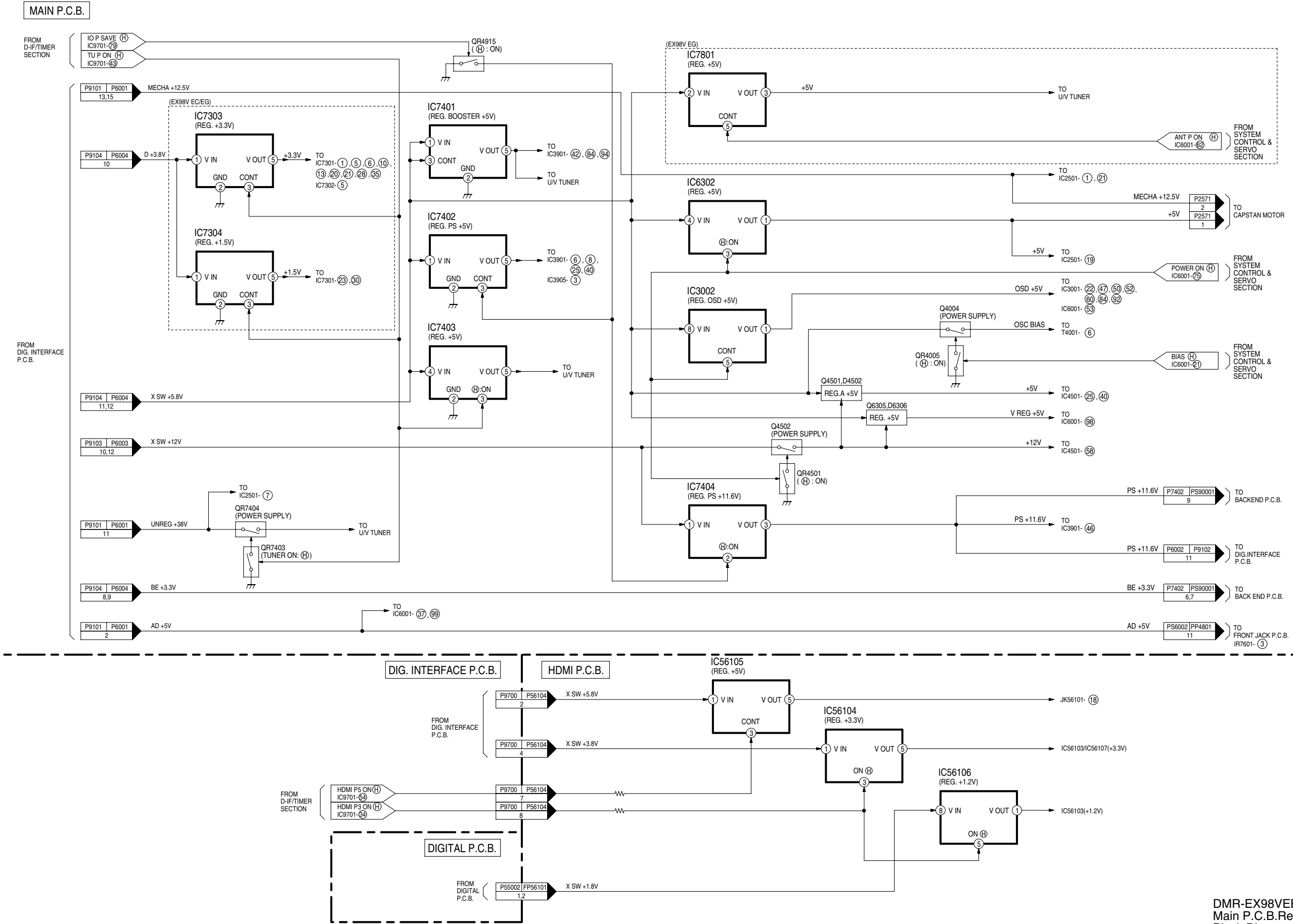

DMR-EX98VEB/EC/EG  
Main P.C.B.Regulator  
Block Diagram

### 11.3. Analog Video (1/2) Block Diagram

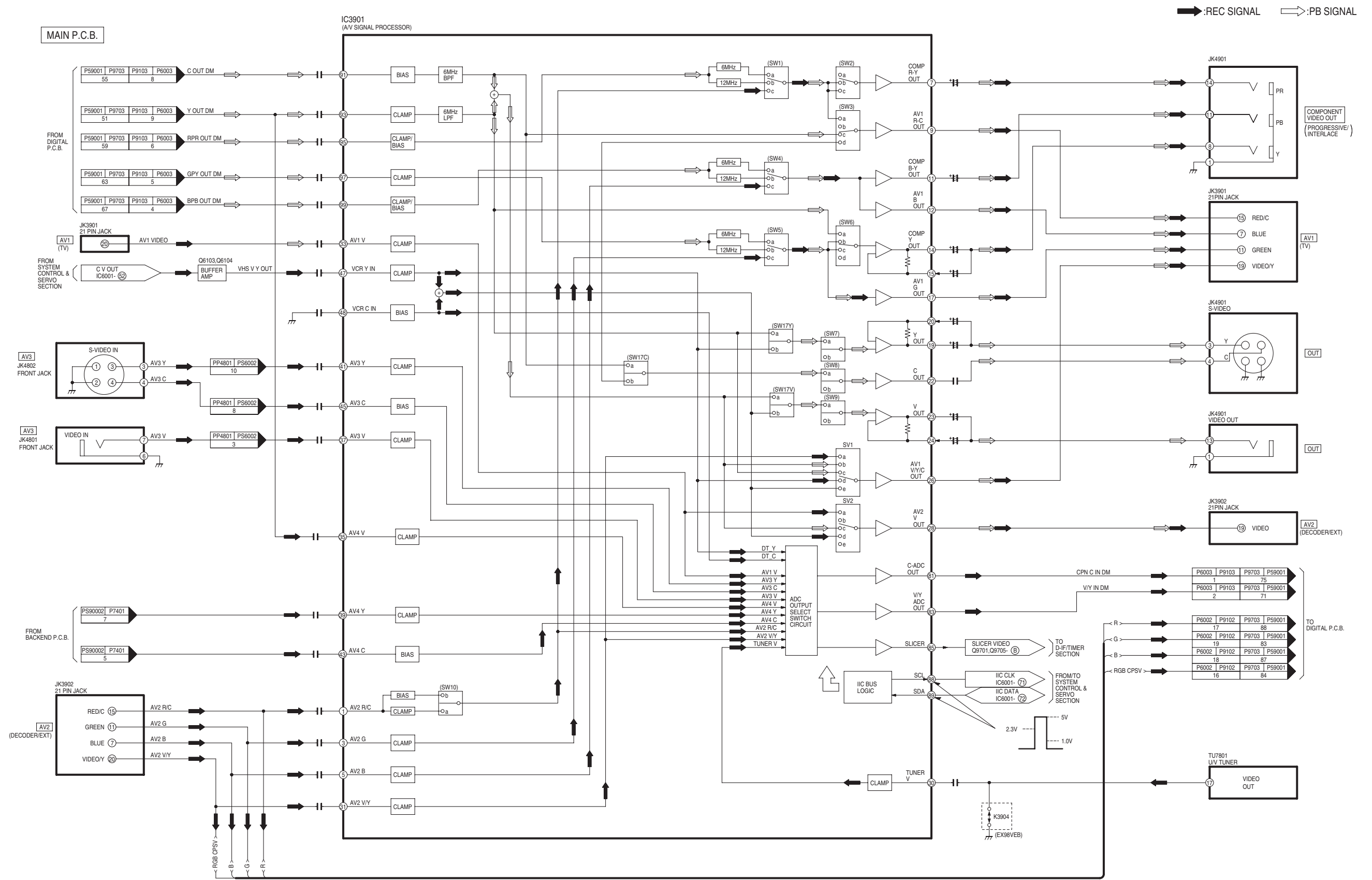

DMR-EX98VEB/EC/EG  
Analog Video (1/2) Block Diagram

# 11.4. Analog Video (2/2) Block Diagram

➔:REC SIGNAL    ⇨:PB SIGNAL

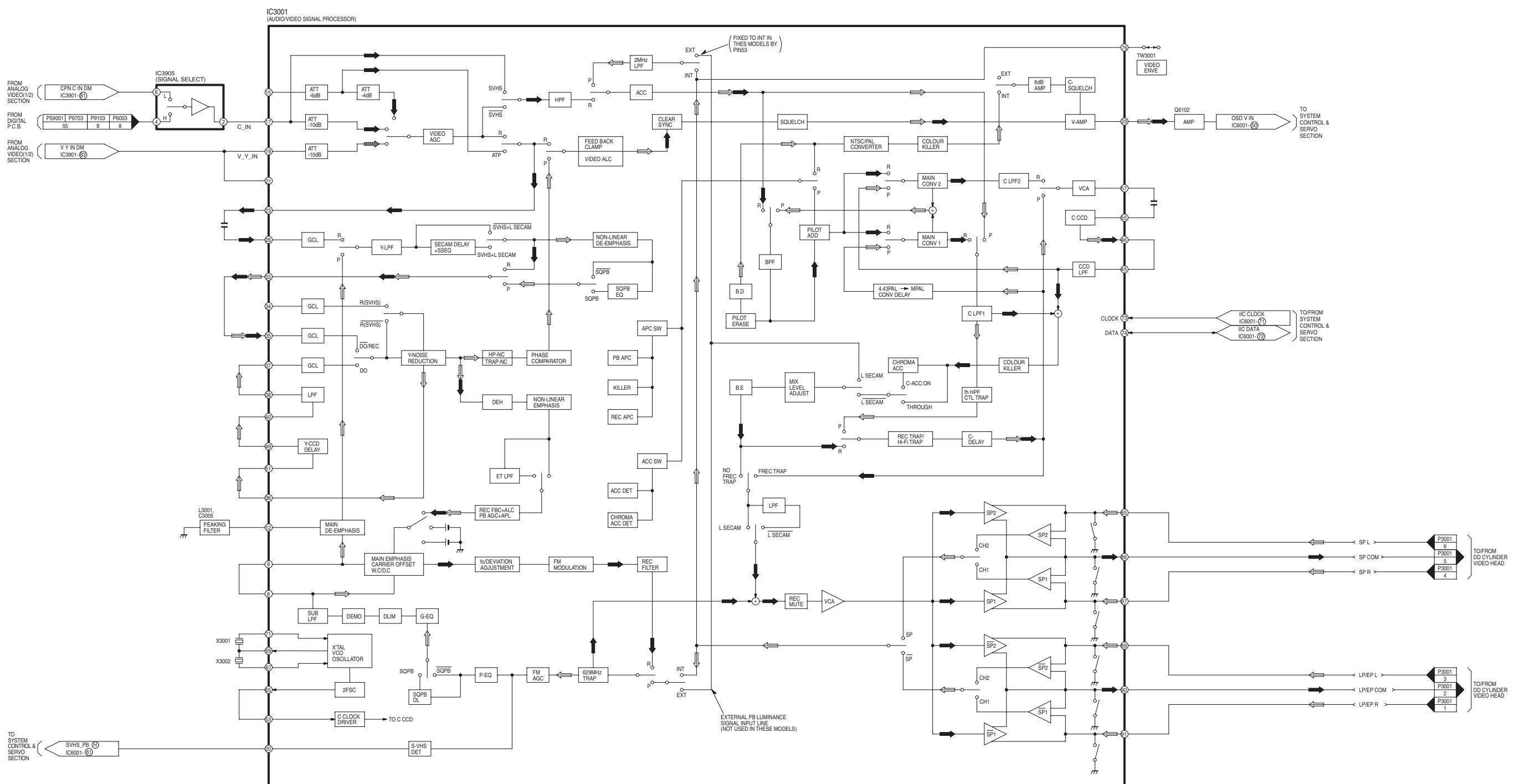

DMR-EX98VEB/EC/EG  
Analog Video (2/2) Block Diagram

### 11.5. Analog Audio Block Diagram

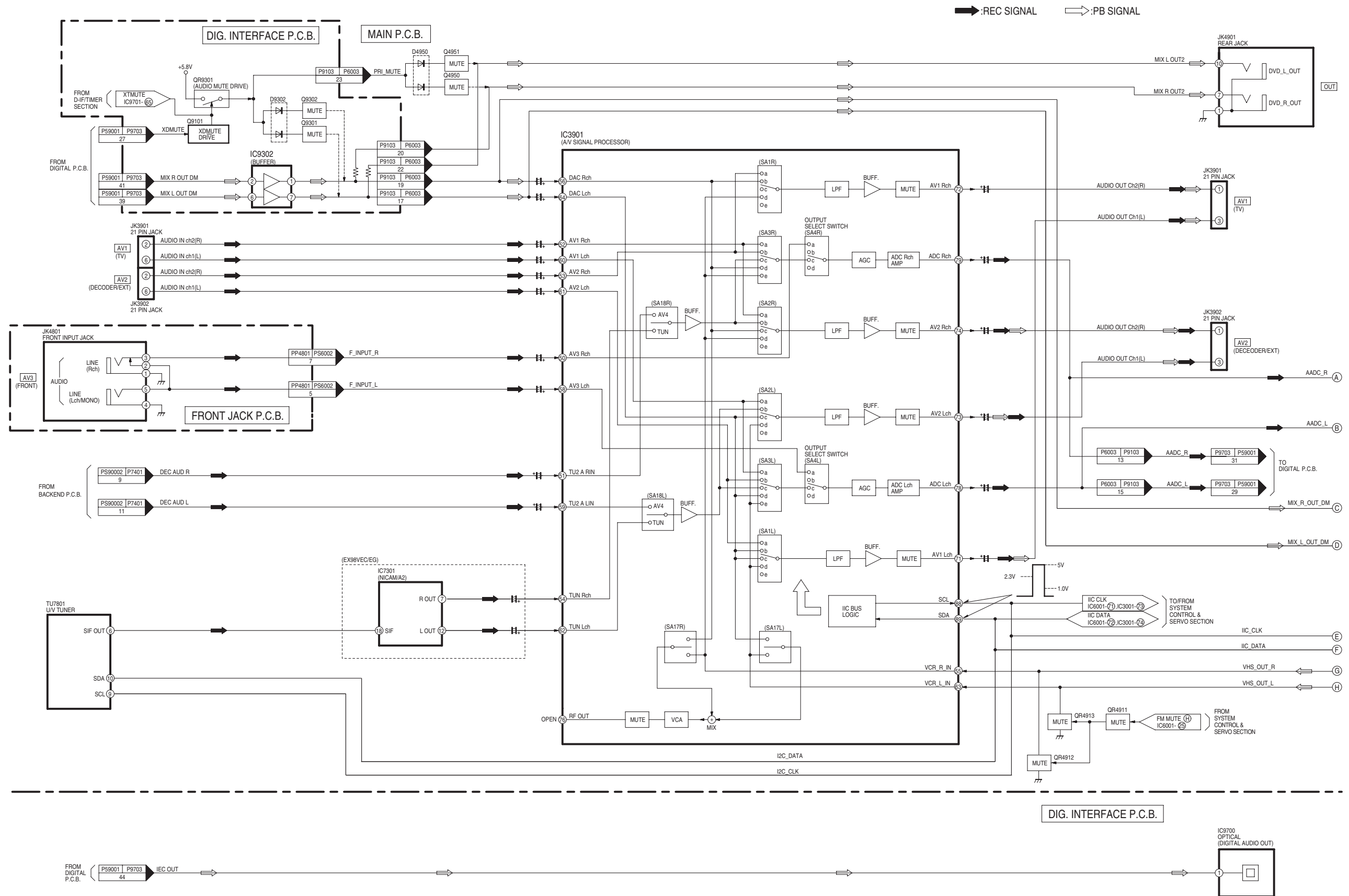

DMR-EX98VEB/EC/EG  
Analog Audio (1/2) Block Diagram

➔:REC SIGNAL    ⇨:PB SIGNAL

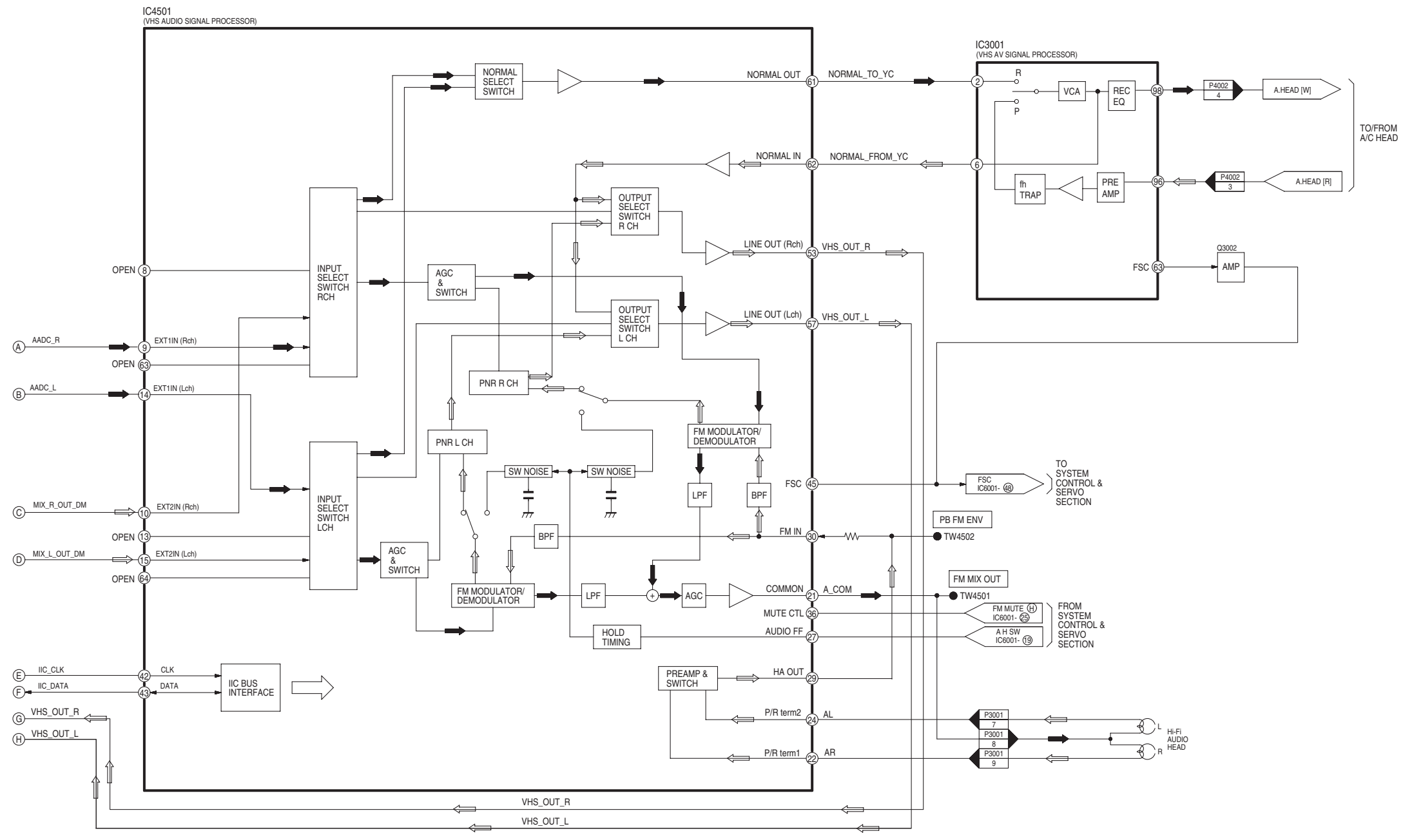

DMR-EX98VEB/EC/EG  
Analog Audio (2/2) Block Diagram

### 11.6. D-IF/Timer Block Diagram

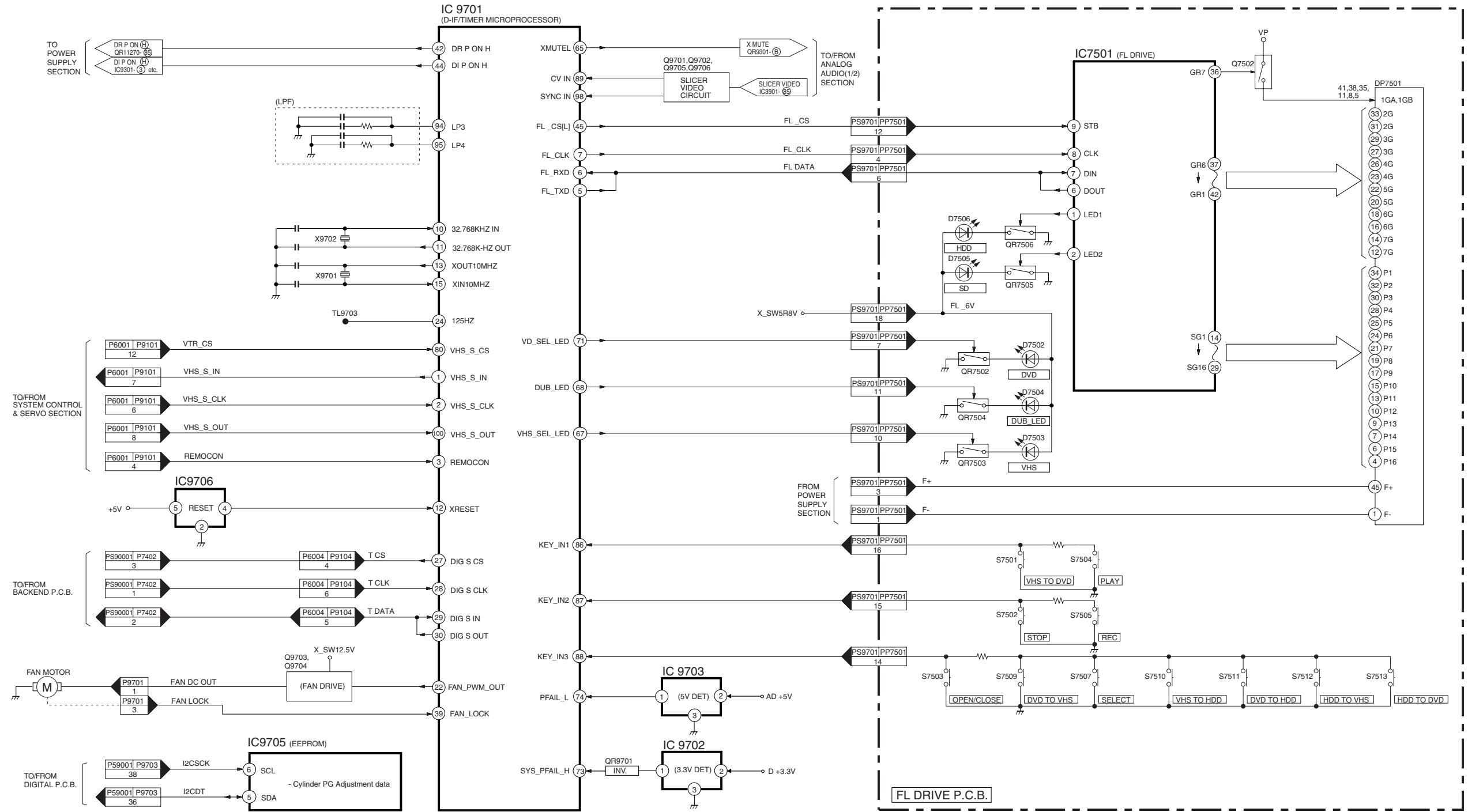

DMR-EX98VEB/EC/EG  
D-IF/Timer  
Block Diagram

# 11.7. System Control & Servo Block Diagram

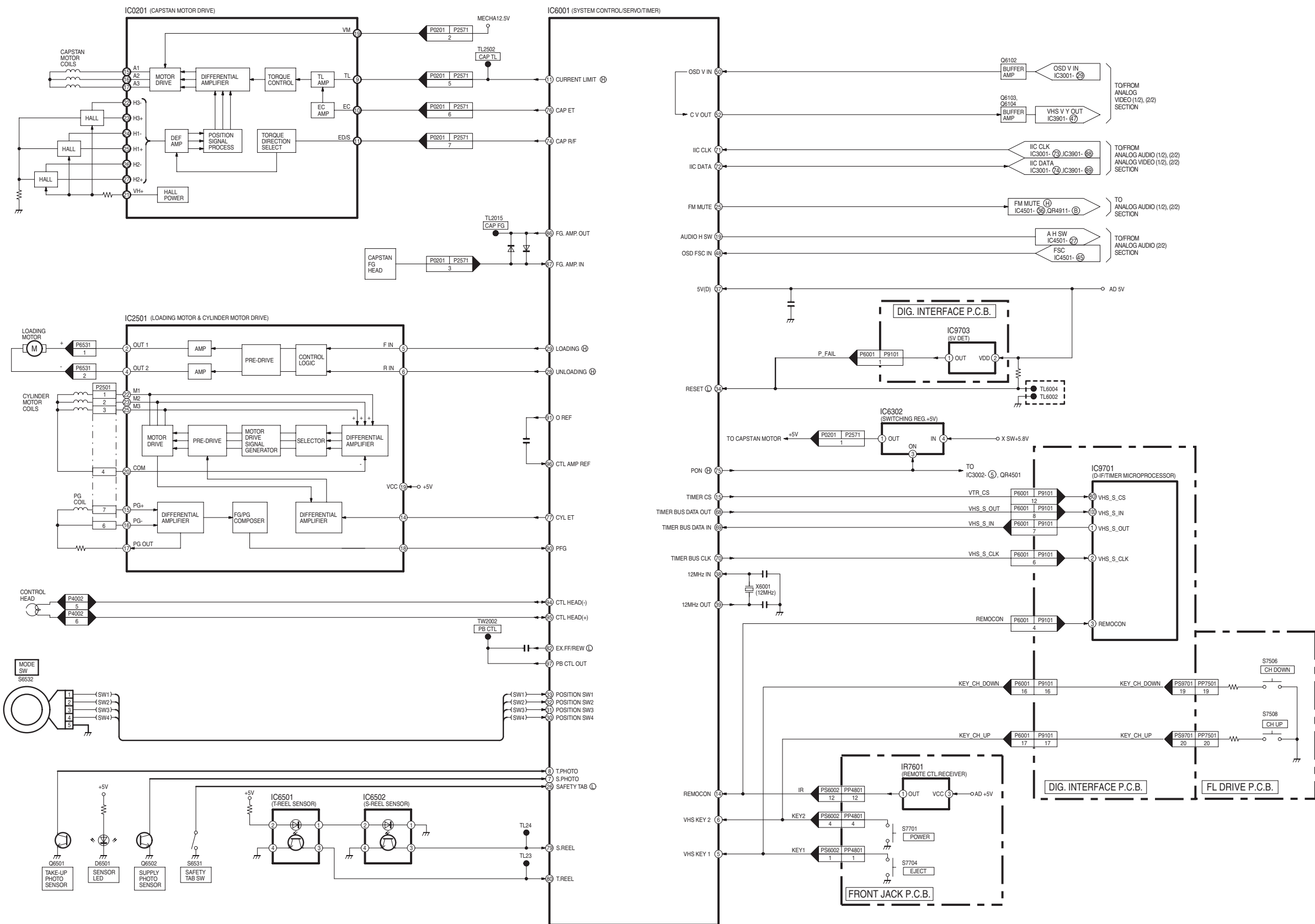

DMR-EX98VEB/EC/EG  
System Control & Servo  
Block Diagram

### 11.8. HDMI Block Diagram

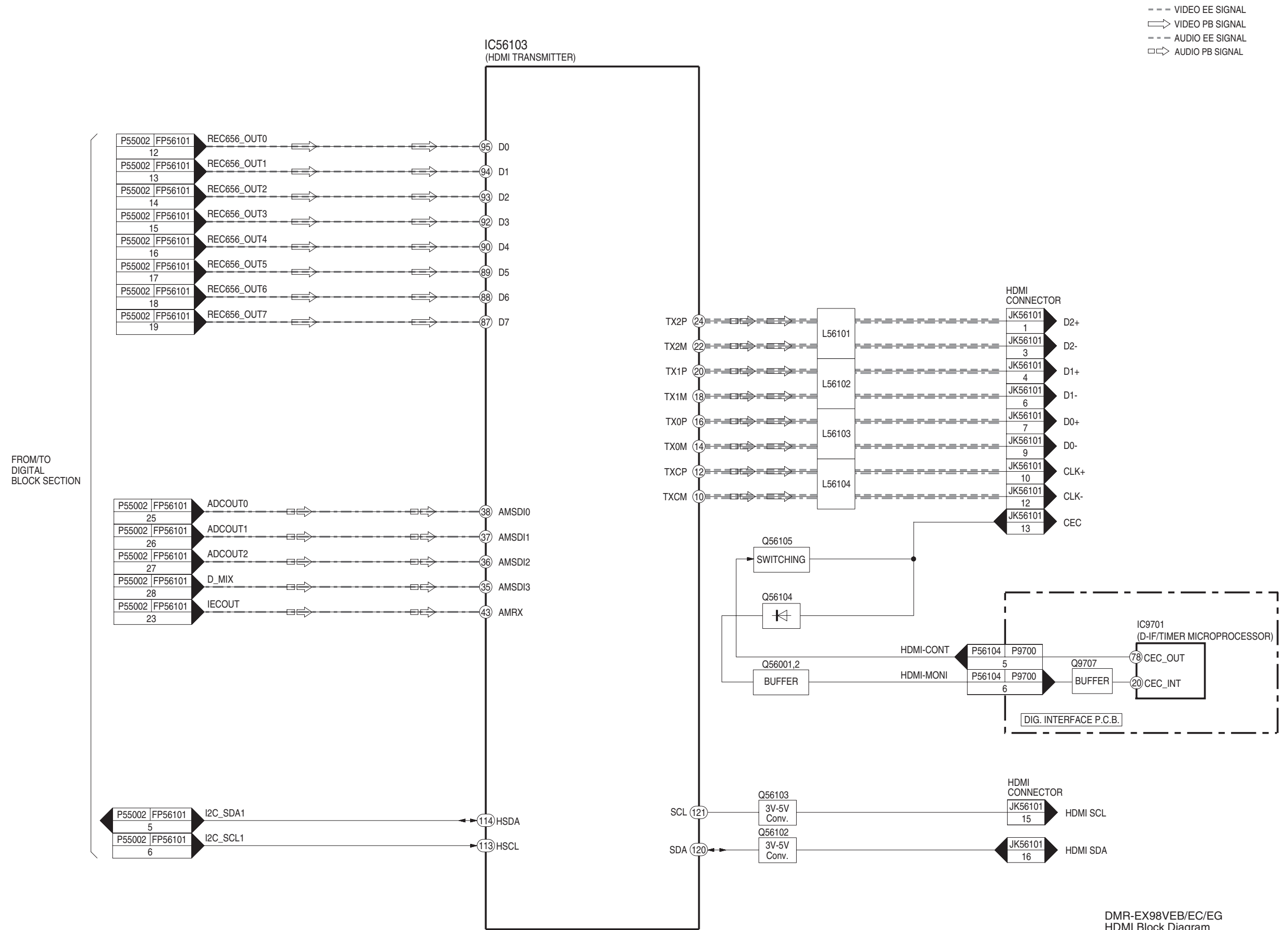

DMR-EX98VEB/EC/EG  
HDMI Block Diagram



# 12 Schematic Diagram

## 12.1. Interconnection Schematic Diagram

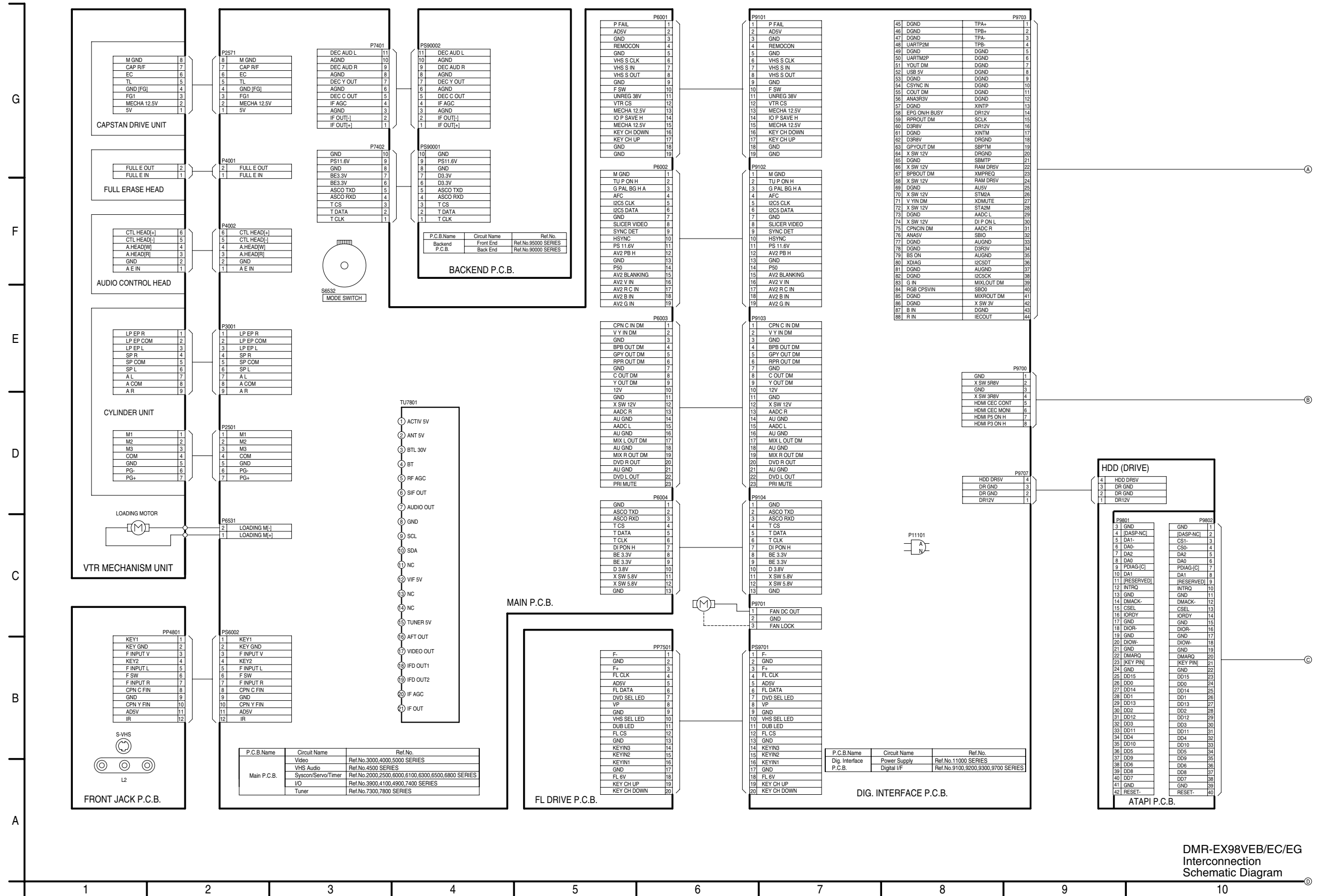

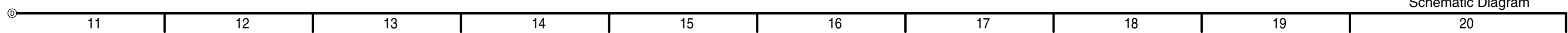
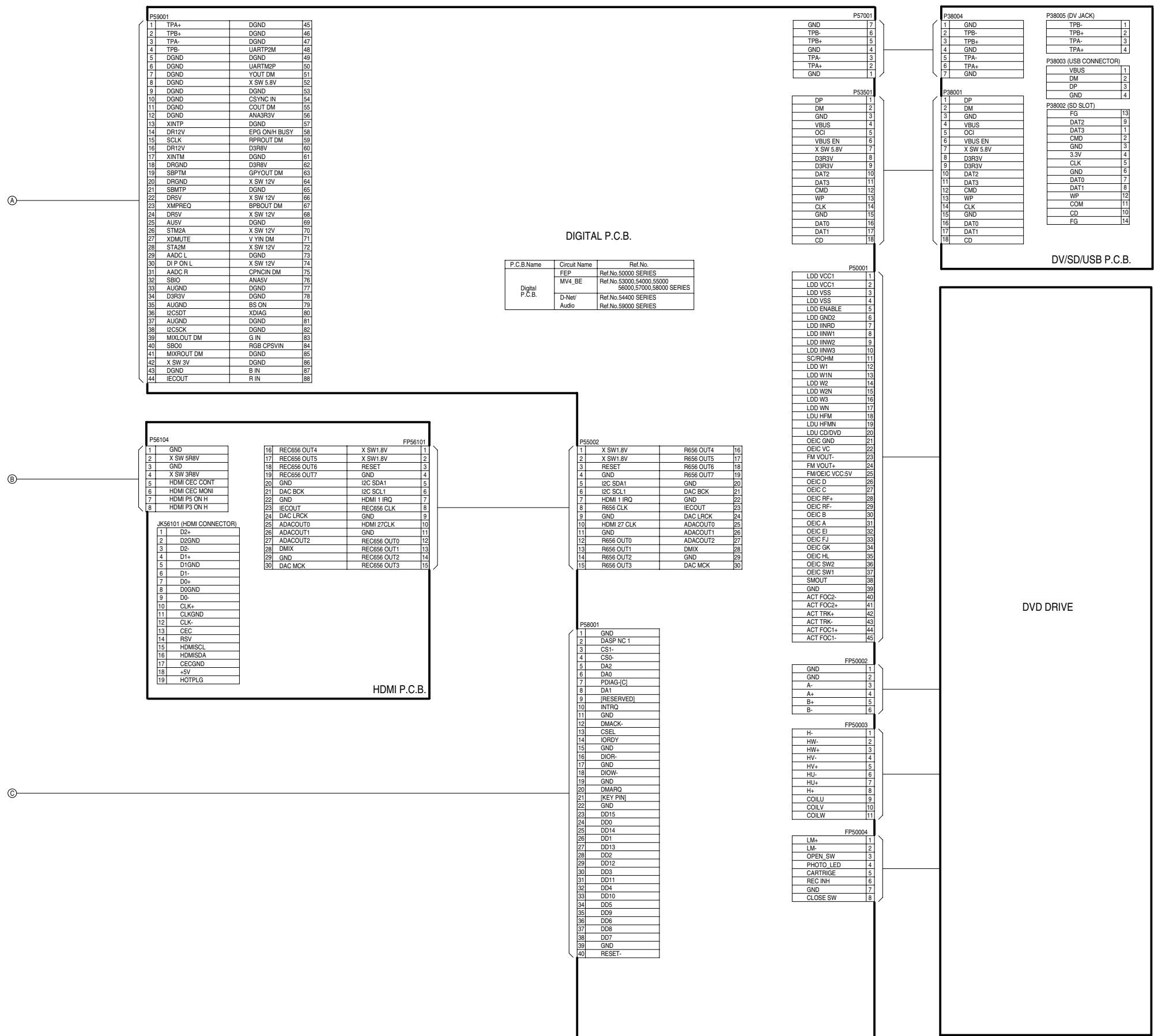

DMR-EX98VEB/EC/EG Interconnection Schematic Diagram

# 12.2. Power Supply Section (Dig. Interface P.C.B. (1/2)) Schematic Diagram (P)

A

P:Power Supply Section (Page: A)  
IF:Digital I/F Section (Page: B)

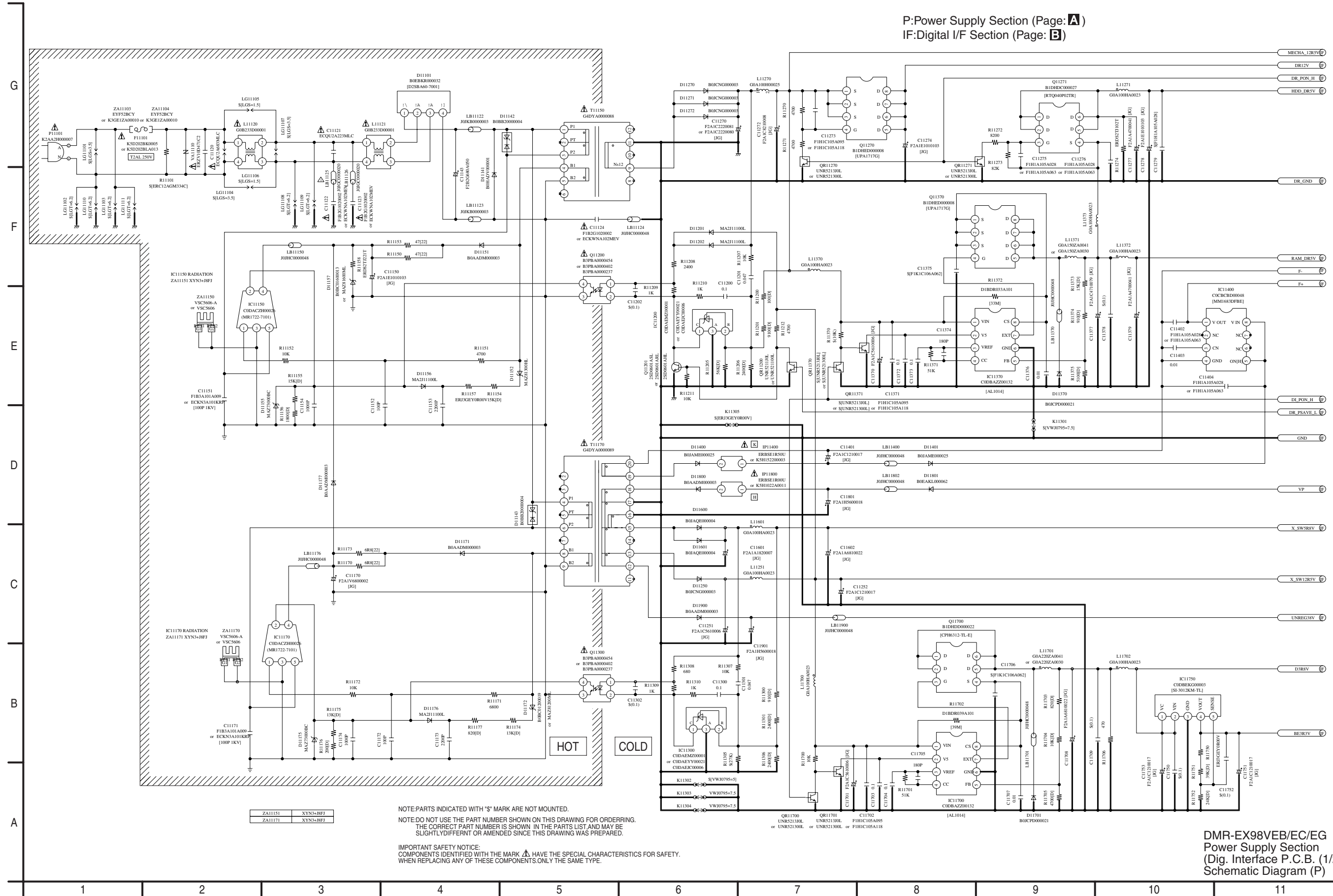

ZA1151	XYN3-BFJ
ZA1171	XYN3-BFJ

NOTE: PARTS INDICATED WITH "\*" MARK ARE NOT MOUNTED.  
 NOTE: DO NOT USE THE PART NUMBER SHOWN ON THIS DRAWING FOR ORDERING.  
 THE CORRECT PART NUMBER IS SHOWN IN THE PARTS LIST AND MAY BE SLIGHTLY DIFFERENT OR AMENDED SINCE THIS DRAWING WAS PREPARED.

IMPORTANT SAFETY NOTICE:  
 COMPONENTS IDENTIFIED WITH THE MARK  $\Delta$  HAVE THE SPECIAL CHARACTERISTICS FOR SAFETY.  
 WHEN REPLACING ANY OF THESE COMPONENTS ONLY THE SAME TYPE.

DMR-EX98VEB/EC/EG  
 Power Supply Section  
 (Dig. Interface P.C.B. (1/2))  
 Schematic Diagram (P)

**IC11150,11170  
SWITCHING IC  
IC-DETAIL BLOCK DIAGRAM**

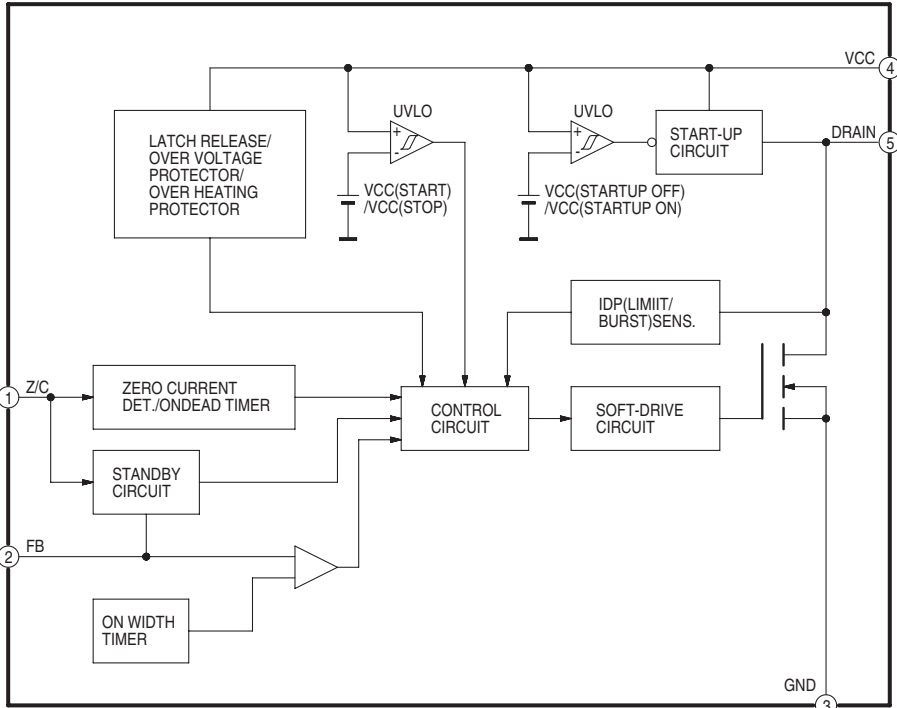

**IC11400  
F+ SWITCHING REGULATOR  
IC-DETAIL BLOCK DIAGRAM**

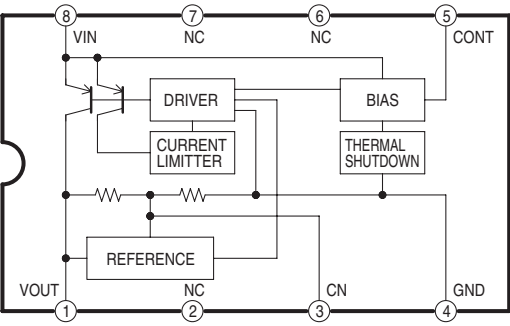

**IC11370,11700  
SWITCHING REGULATOR  
IC-DETAIL BLOCK DIAGRAM**

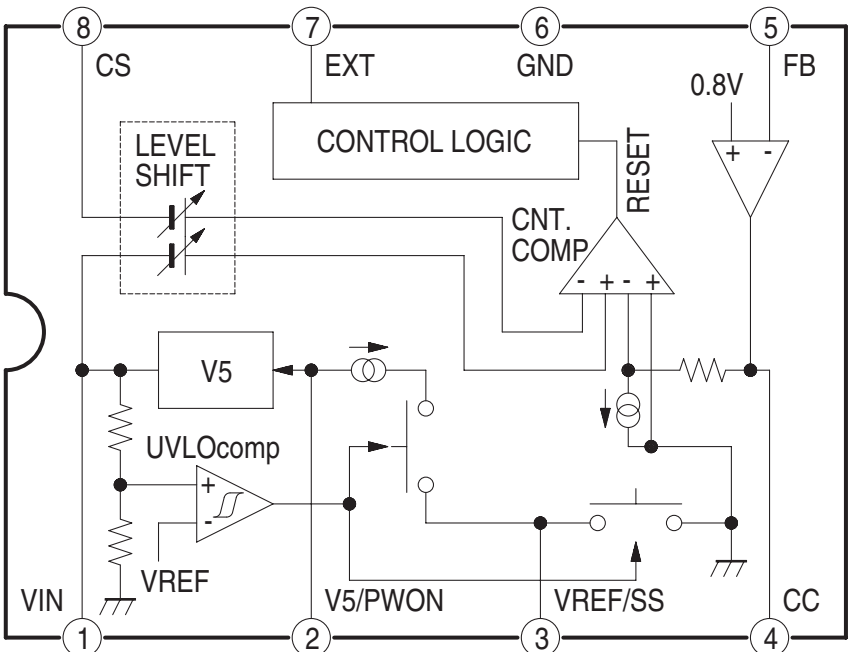

**IC11750  
BE +3.3V SWITCHING REGULATOR  
IC-DETAIL BLOCK DIAGRAM**

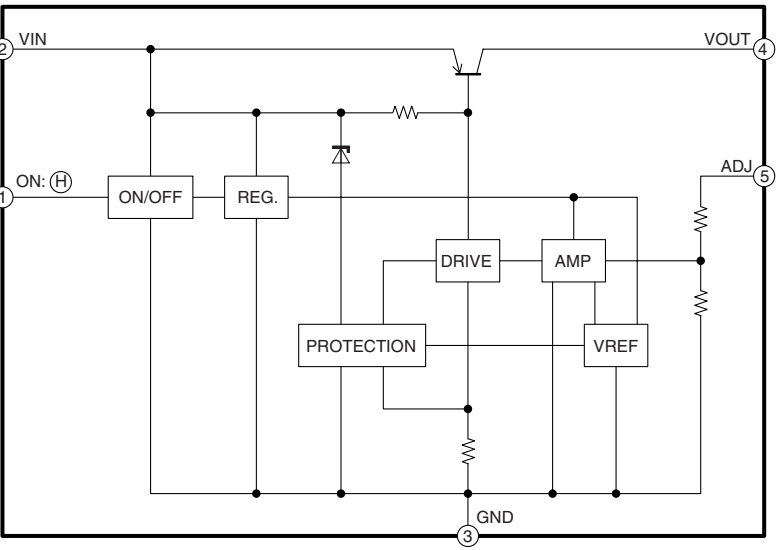

IC11150 Detail Block Diagram  
 IC11170 Detail Block Diagram  
 IC11370 Detail Block Diagram  
 IC11400 Detail Block Diagram  
 IC11700 Detail Block Diagram  
 IC11750 Detail Block Diagram  
 DMR-EX98VEB/EC/EG IC-Detail Block Diagram

### 12.3. Digital I/F (1/4) Section (Dig. Interface P.C.B. (2/2)) Schematic Diagram (IF)

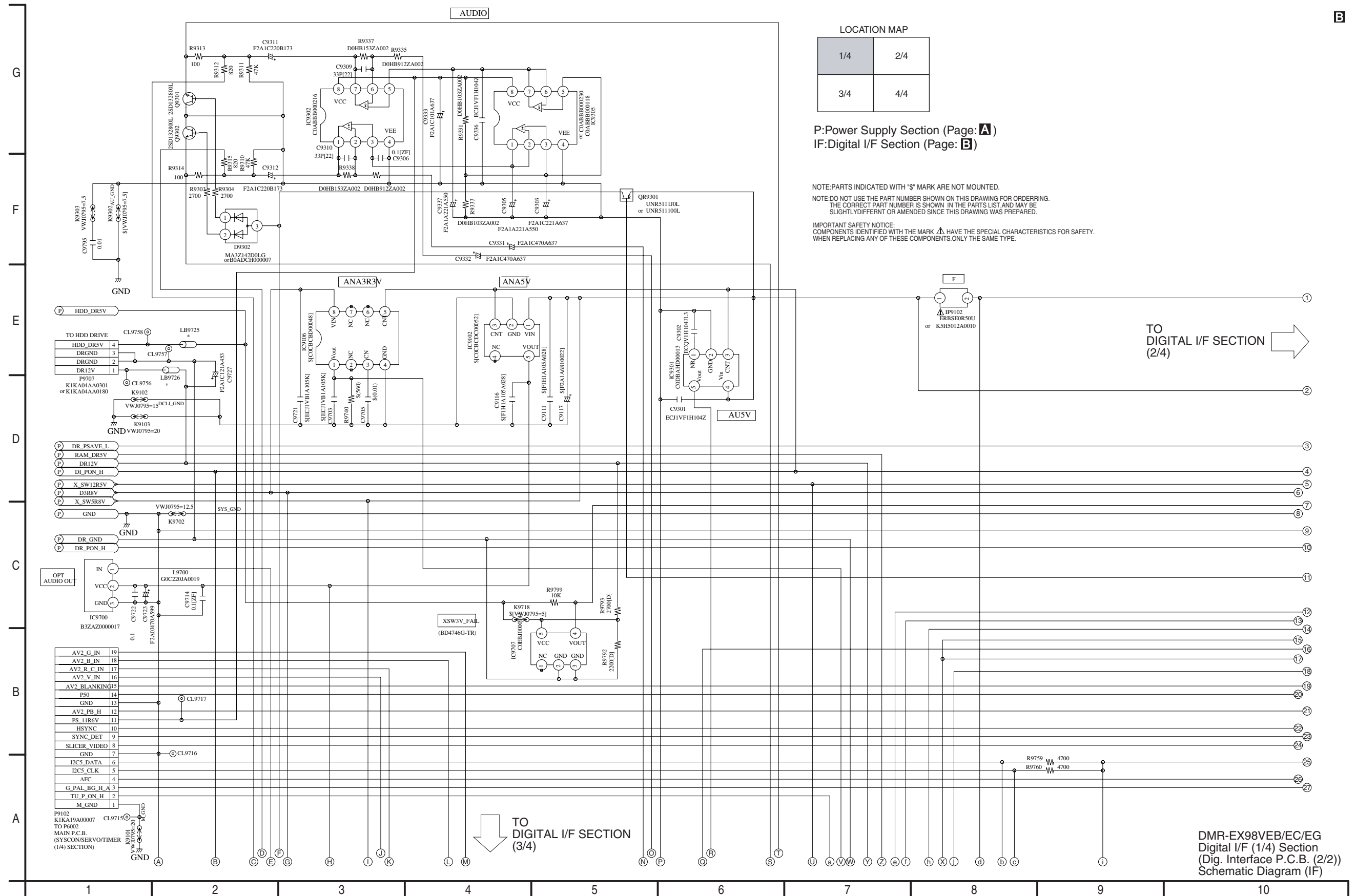

### 12.4. Digital I/F (2/4) Section (Dig. Interface P.C.B. (2/2)) Schematic Diagram (IF)

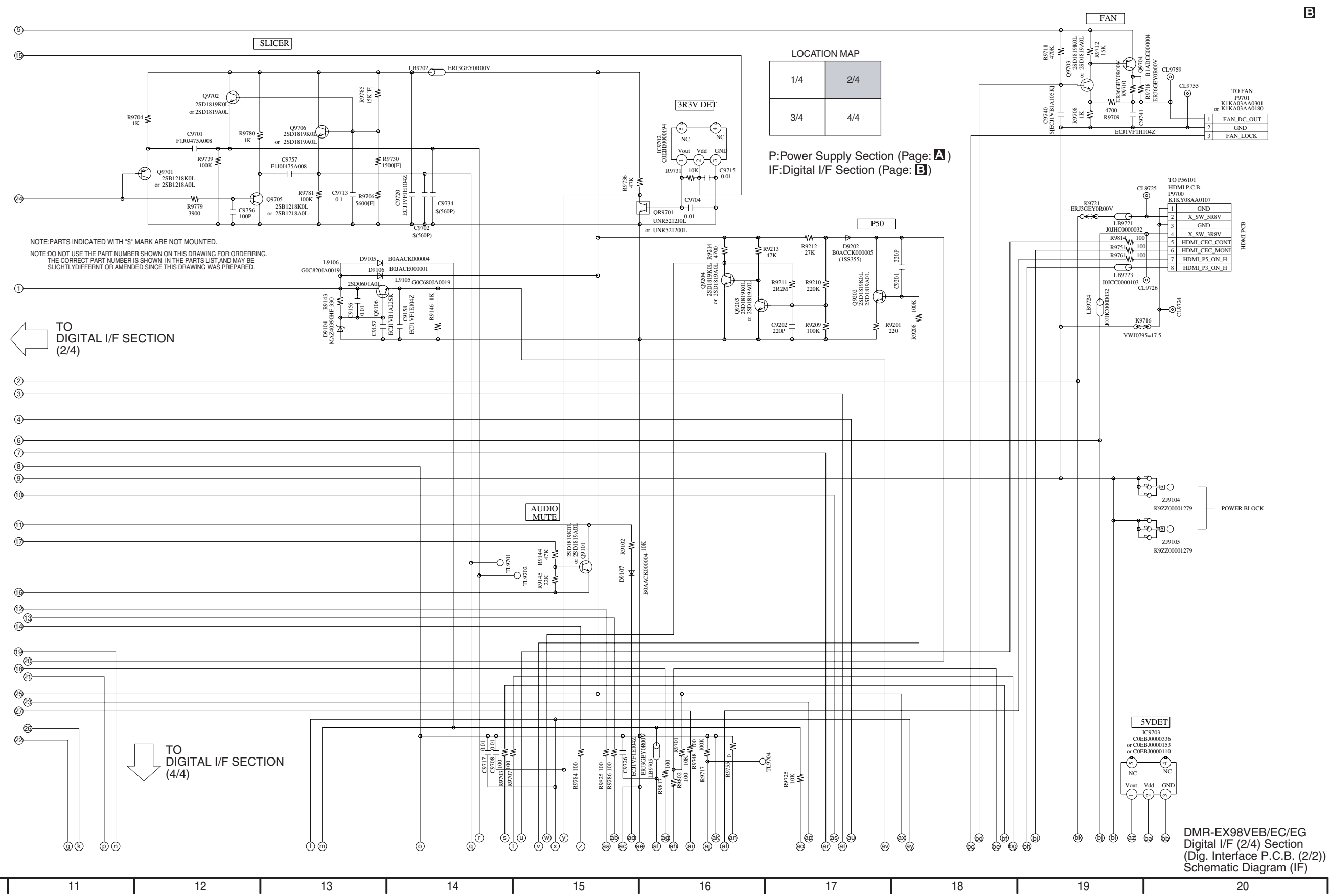

### 12.5. Digital I/F (3/4) Section (Dig. Interface P.C.B. (2/2)) Schematic Diagram (IF)

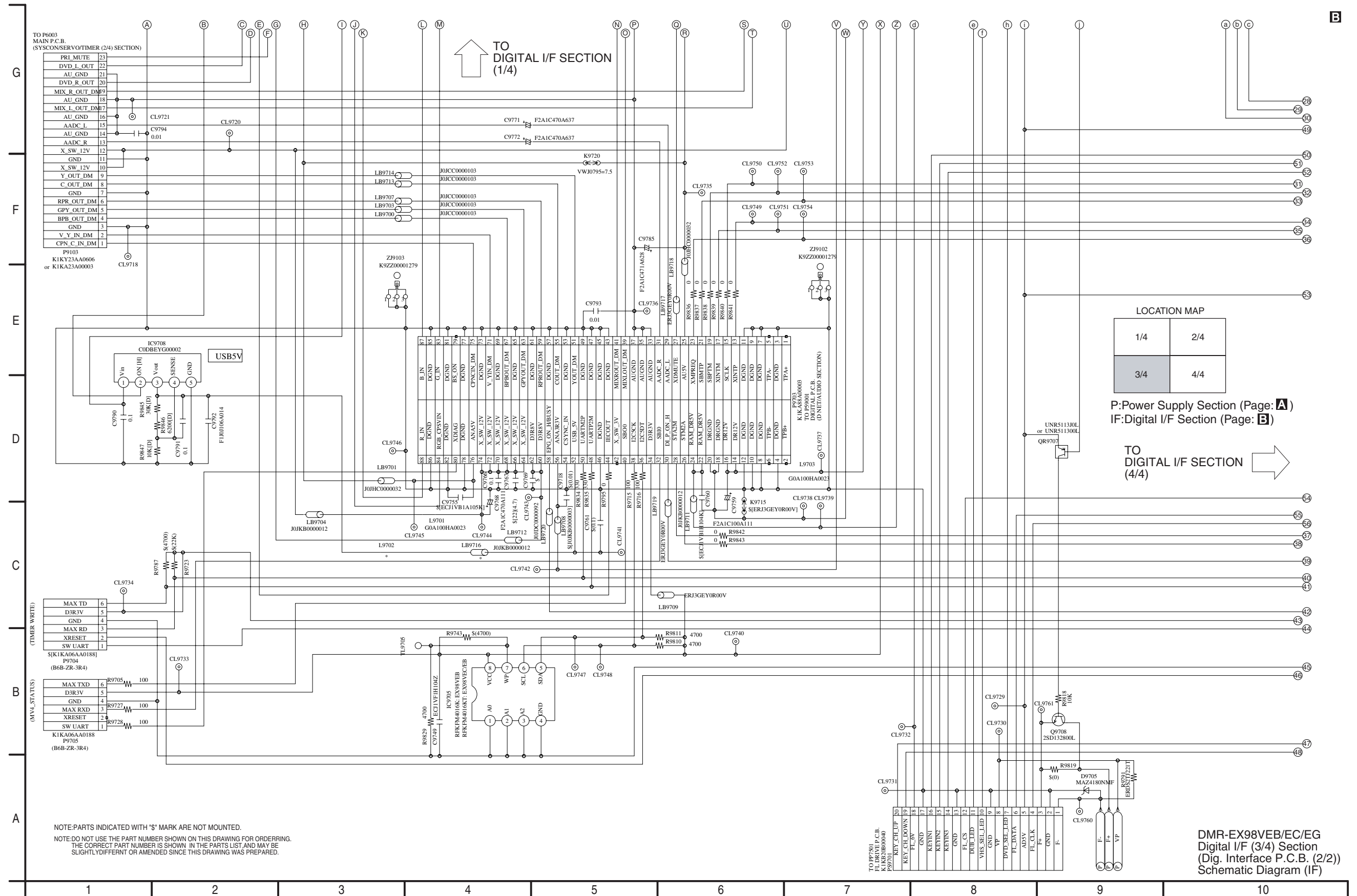

DMR-EX98VEB/EC/EG  
Digital I/F (3/4) Section  
(Dig. Interface P.C.B. (2/2))  
Schematic Diagram (IF)

# 12.6. Digital I/F (4/4) Section (Dig. Interface P.C.B. (2/2)) Schematic Diagram (IF)

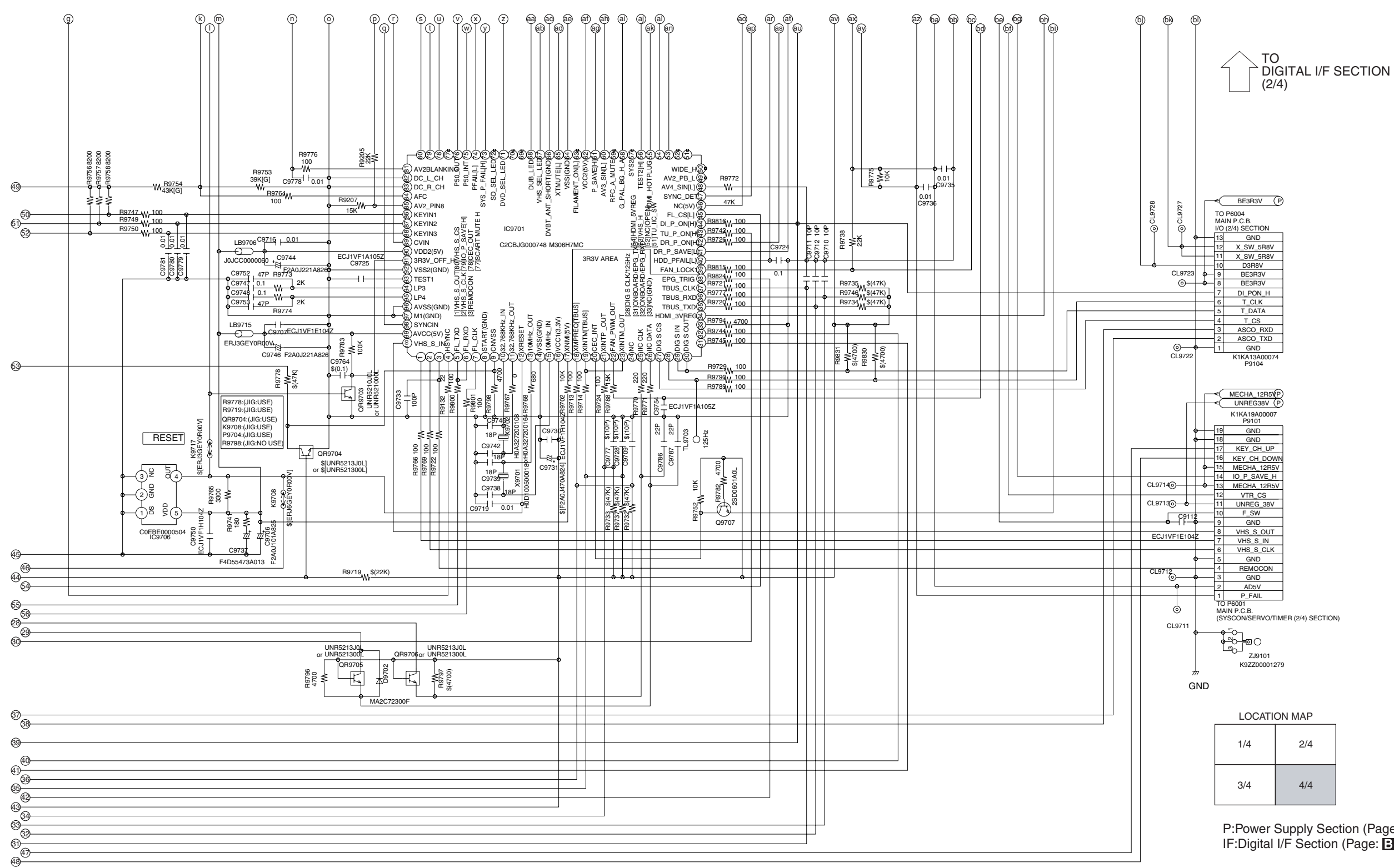

↑ TO DIGITAL I/F SECTION (2/4)

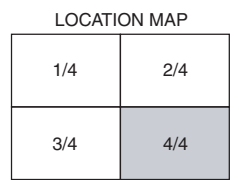
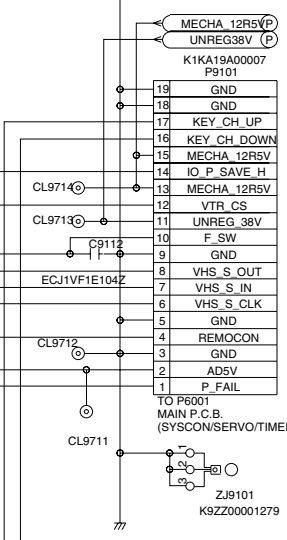
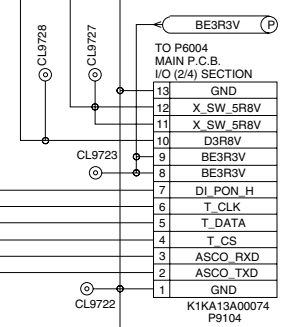

P:Power Supply Section (Page: **A**)  
IF:Digital I/F Section (Page: **B**)

← TO DIGITAL I/F SECTION (3/4)

VariationCategory	A	B	C	Z
L9702	VWJ0795=5	VWJ0795=5	VWJ0795=5	GOA100HA0203
LB9714	VWJ0795=5	VWJ0795=5	VWJ0795=5	JKJ80000012
LB9725	VWJ0795=5	VWJ0795=5	VWJ0795=5	JKJ80000012
LB9724	VWJ0795=5	VWJ0795=5	VWJ0795=5	JKJ80000012

Modify Category	Variation	Type
1	EX98V-EG	A
2	EX98V-EG	B
3	EX98V-EC	C
4	JISSOU	Z

NOTE:PARTS INDICATED WITH "S" MARK ARE NOT MOUNTED.  
NOTE:DO NOT USE THE PART NUMBER SHOWN ON THIS DRAWING FOR ORDERING.  
THE CORRECT PART NUMBER IS SHOWN IN THE PARTS LIST AND MAY BE SLIGHTLYDIFFERENT OR AMENDED SINCE THIS DRAWING WAS PREPARED.

DMR-EX98VEB/EC/EG  
Digital I/F (4/4) Section  
(Dig. Interface P.C.B. (2/2))  
Schematic Diagram (IF)

**IC9301**  
**AU +5V SWITCHING REG.**  
**IC-DETAIL BLOCK DIAGRAM**

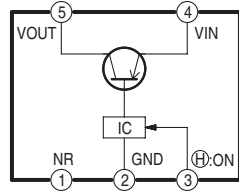

**IC9703**  
**+5V DETECTOR**  
**IC-DETAIL BLOCK DIAGRAM**

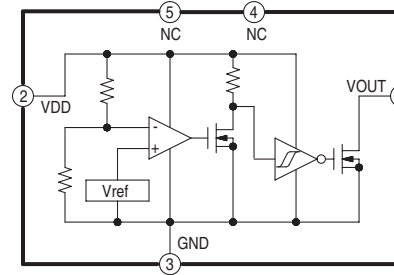

**IC9708**  
**USB +5V SWITCHING REG.**  
**IC-DETAIL BLOCK DIAGRAM**

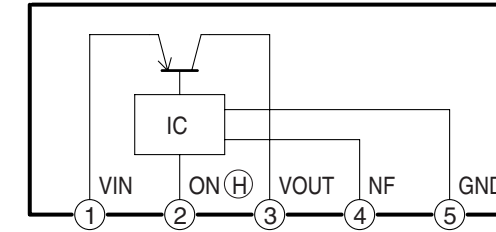

**IC9700**  
**OPTICAL (DIGITAL AUDIO OUT)**  
**IC-DETAIL BLOCK DIAGRAM**

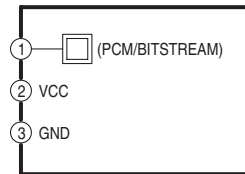

**IC9706**  
**RESET**  
**IC-DETAIL BLOCK DIAGRAM**

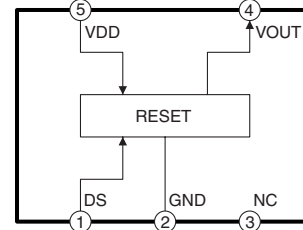

**IC9705**  
**EEPROM**  
**IC-DETAIL BLOCK DIAGRAM**

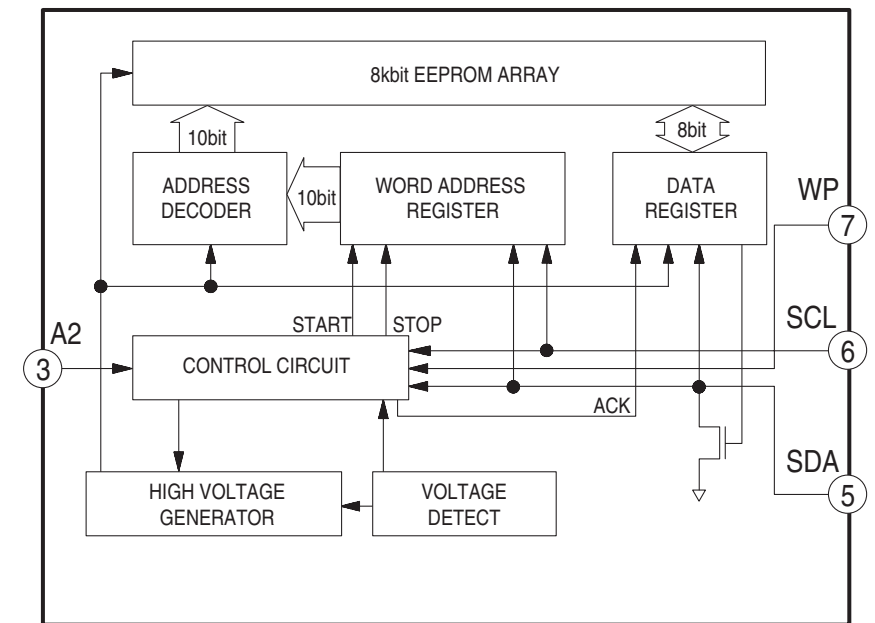

**IC9702**  
**+3.3V DETECTOR**  
**IC-DETAIL BLOCK DIAGRAM**

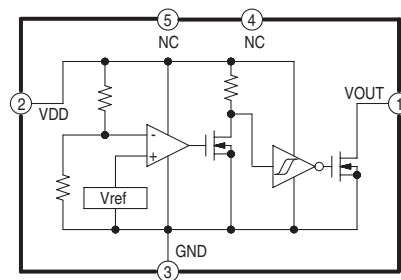

**IC9707**  
**RESET**  
**IC-DETAIL BLOCK DIAGRAM**

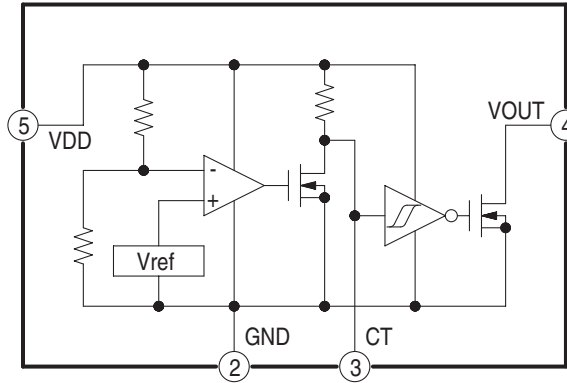

IC9301 Detail Block Diagram  
 IC9700 Detail Block Diagram  
 IC9702 Detail Block Diagram  
 IC9703 Detail Block Diagram  
 IC9705 Detail Block Diagram  
 IC9706 Detail Block Diagram  
 IC9707 Detail Block Diagram  
 IC9708 Detail Block Diagram  
 DMR-EX98VEB/EC/EG IC-Detail Block Diagram

### 12.7. Video Section (Main P.C.B. (1/5)) Schematic Diagram (V)

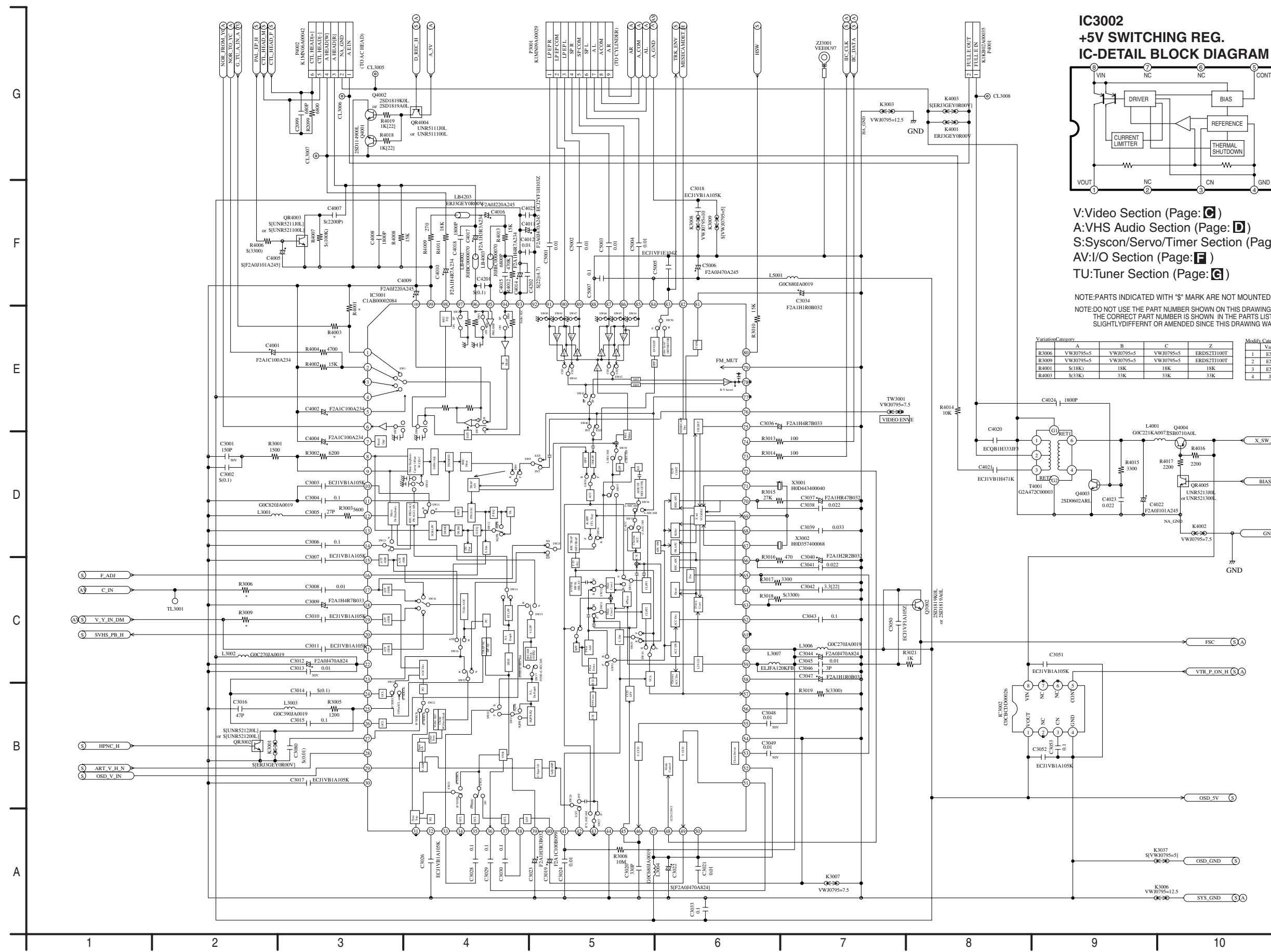

**IC3002**  
**+5V SWITCHING REG.**  
**IC-DETAIL BLOCK DIAGRAM**

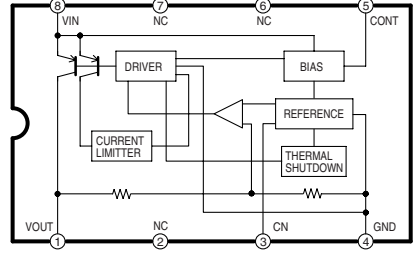

V:Video Section (Page: **G**)  
 A:VHS Audio Section (Page: **D**)  
 S:Syscon/Servo/Timer Section (Page: **E**)  
 AV:I/O Section (Page: **F**)  
 TU:Tuner Section (Page: **C**)

NOTE:PARTS INDICATED WITH "\*" MARK ARE NOT MOUNTED.  
 NOTE:DO NOT USE THE PART NUMBER SHOWN ON THIS DRAWING FOR ORDERING.  
 THE CORRECT PART NUMBER IS SHOWN IN THE PARTS LIST, AND MAY BE SLIGHTLYDIFFERENT OR AMENDED SINCE THIS DRAWING WAS PREPARED.

Variation/Category	A	B	C	Z	Modify Category	Type
R3006	VWJ0795=5	VWJ0795=5	VWJ0795=5	ERDS2T100T	1	EX98V-EB A
R3009	VWJ0795=5	VWJ0795=5	VWJ0795=5	ERDS2T100T	2	EX98V-EG B
R4001	S(18K)	18K	18K	18K	3	EX98V-EC C
R4003	S(33K)	33K	33K	33K	4	JSSOU Z

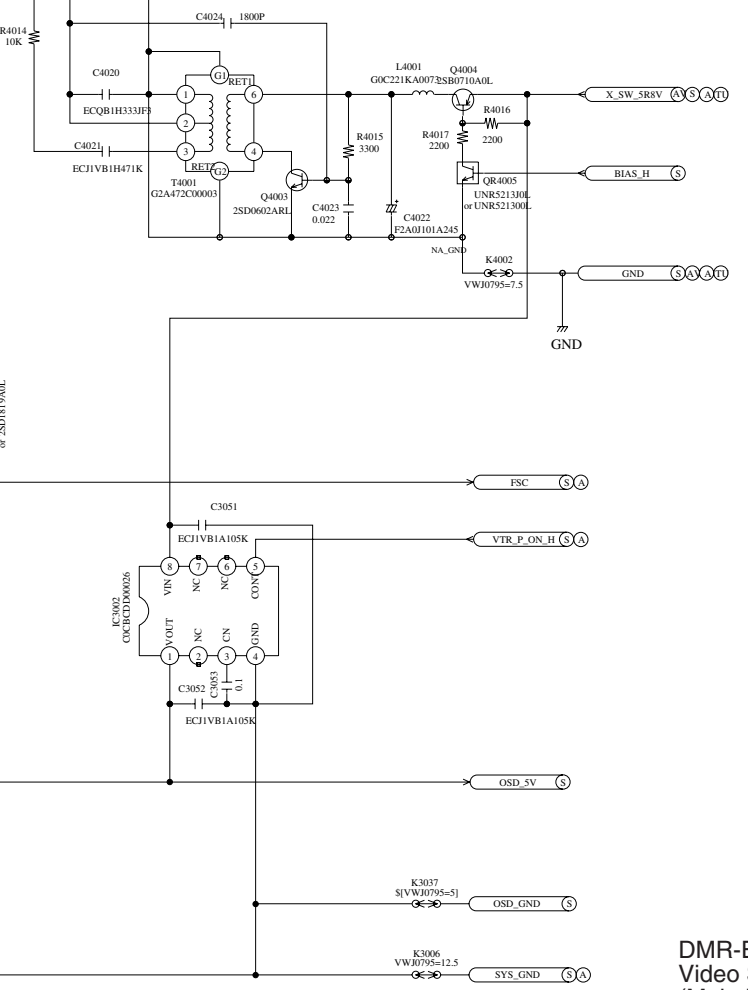

DMR-EX98VEB/EC/EG  
 Video Section  
 (Main P.C.B. (1/5))  
 Schematic Diagram (V)

### 12.8. VHS Audio Section (Main P.C.B. (2/5)) Schematic Diagram (A)

D

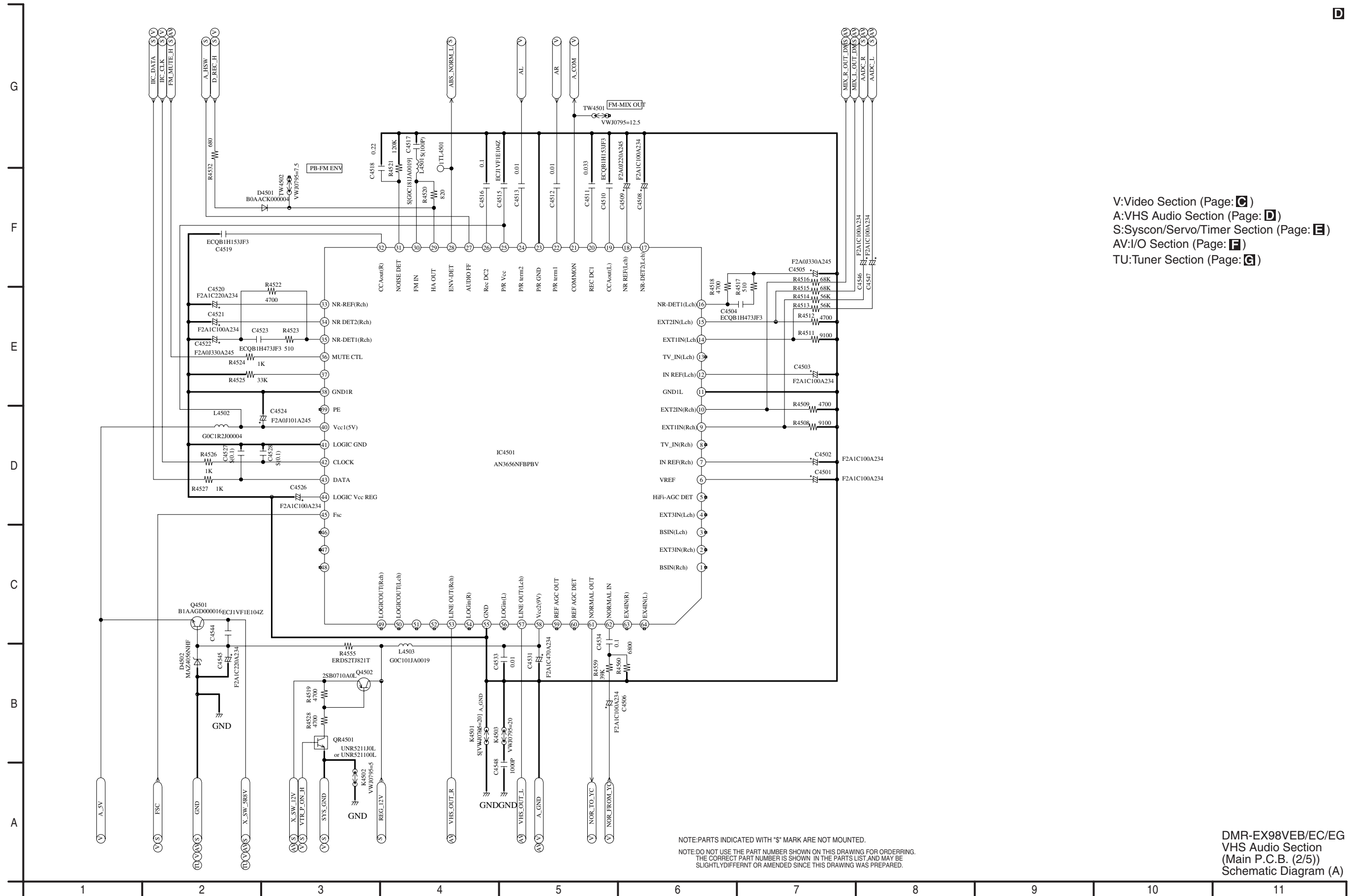

# IC4501 AUDIO PROCESSOR IC-DETAIL BLOCK DIAGRAM

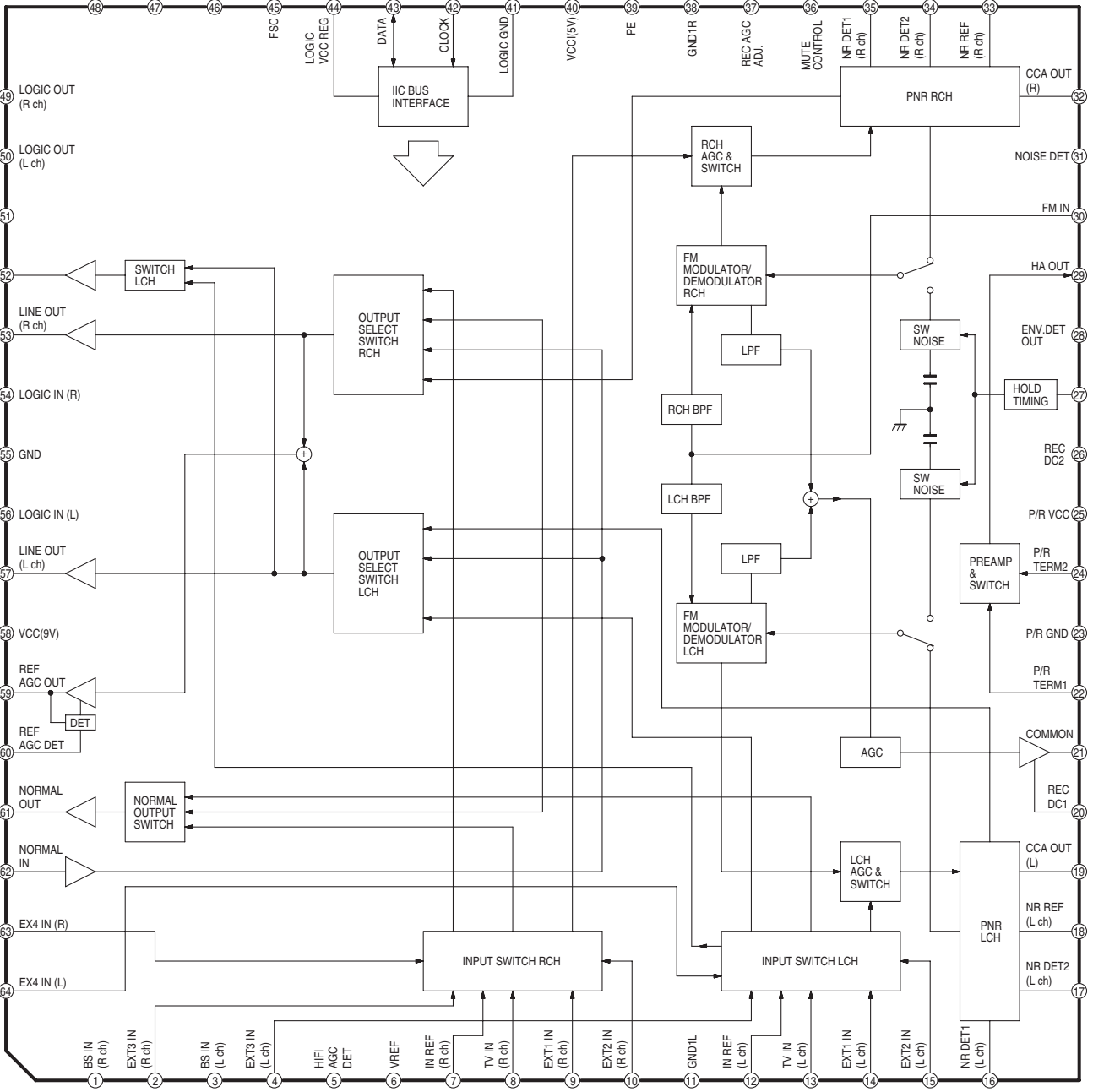

IC4501 Detail Block Diagram  
DMR-EX98VEB/EC/EG IC-Detail Block Diagram

### 12.9. Syscon/Servo/Timer (1/4) Section (Main P.C.B. (3/5)) Schematic Diagram (S)

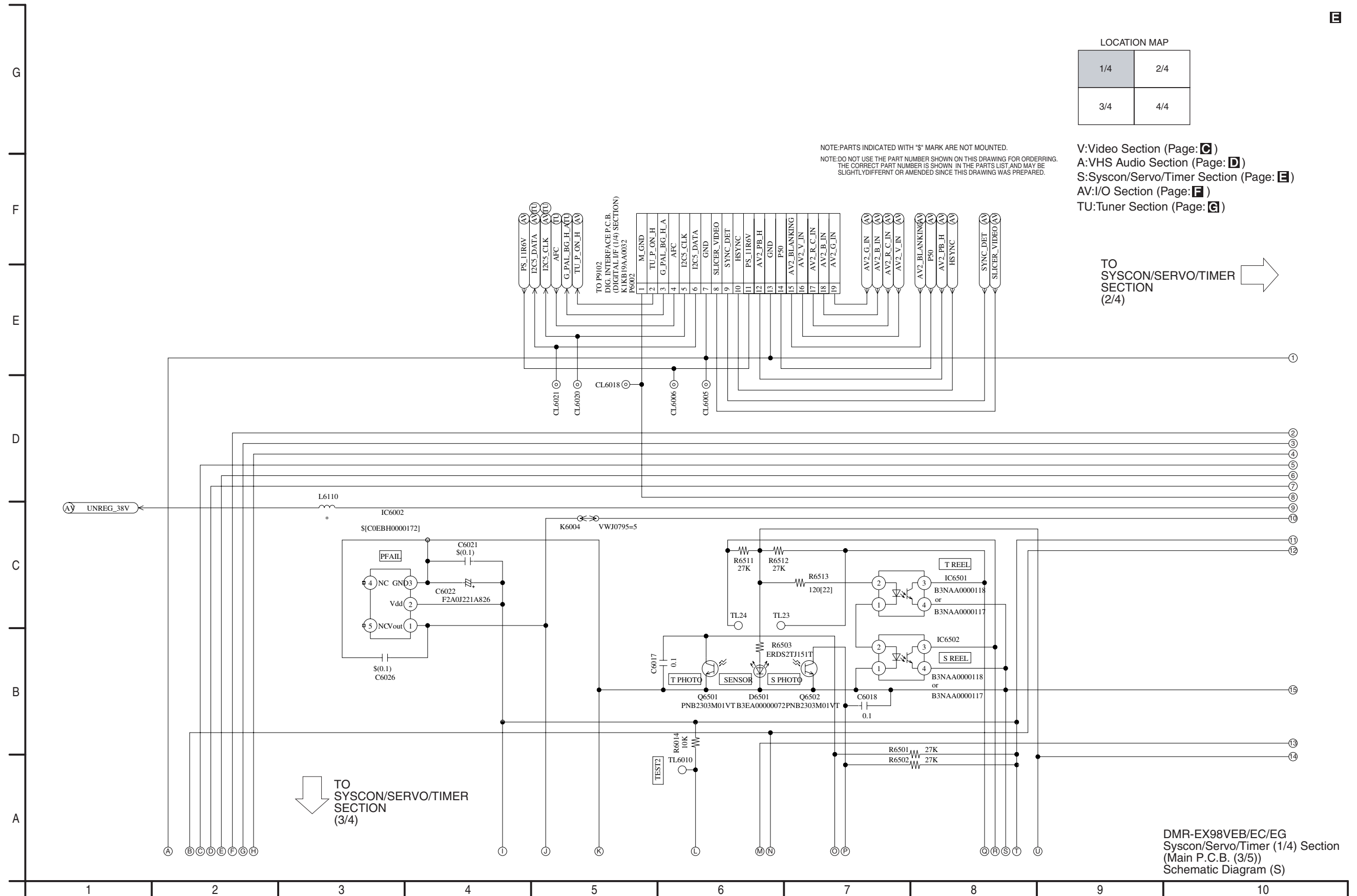

### 12.10. Syscon/Servo/Timer (2/4) Section (Main P.C.B. (3/5)) Schematic Diagram (S)

E

TO  
SYSCON/SERVO/TIMER  
SECTION  
(1/4)

LOCATION MAP

1/4	2/4
3/4	4/4

V:Video Section (Page: **C**)  
 A:VHS Audio Section (Page: **D**)  
 S:Syscon/Servo/Timer Section (Page: **E**)  
 AV:I/O Section (Page: **F**)  
 TU:Tuner Section (Page: **G**)

NOTE: PARTS INDICATED WITH "S" MARK ARE NOT MOUNTED.  
 NOTE: DO NOT USE THE PART NUMBER SHOWN ON THIS DRAWING FOR ORDERING.  
 THE CORRECT PART NUMBER IS SHOWN IN THE PARTS LIST AND MAY BE  
 SLIGHTLY DIFFERENT OR AMENDED SINCE THIS DRAWING WAS PREPARED.

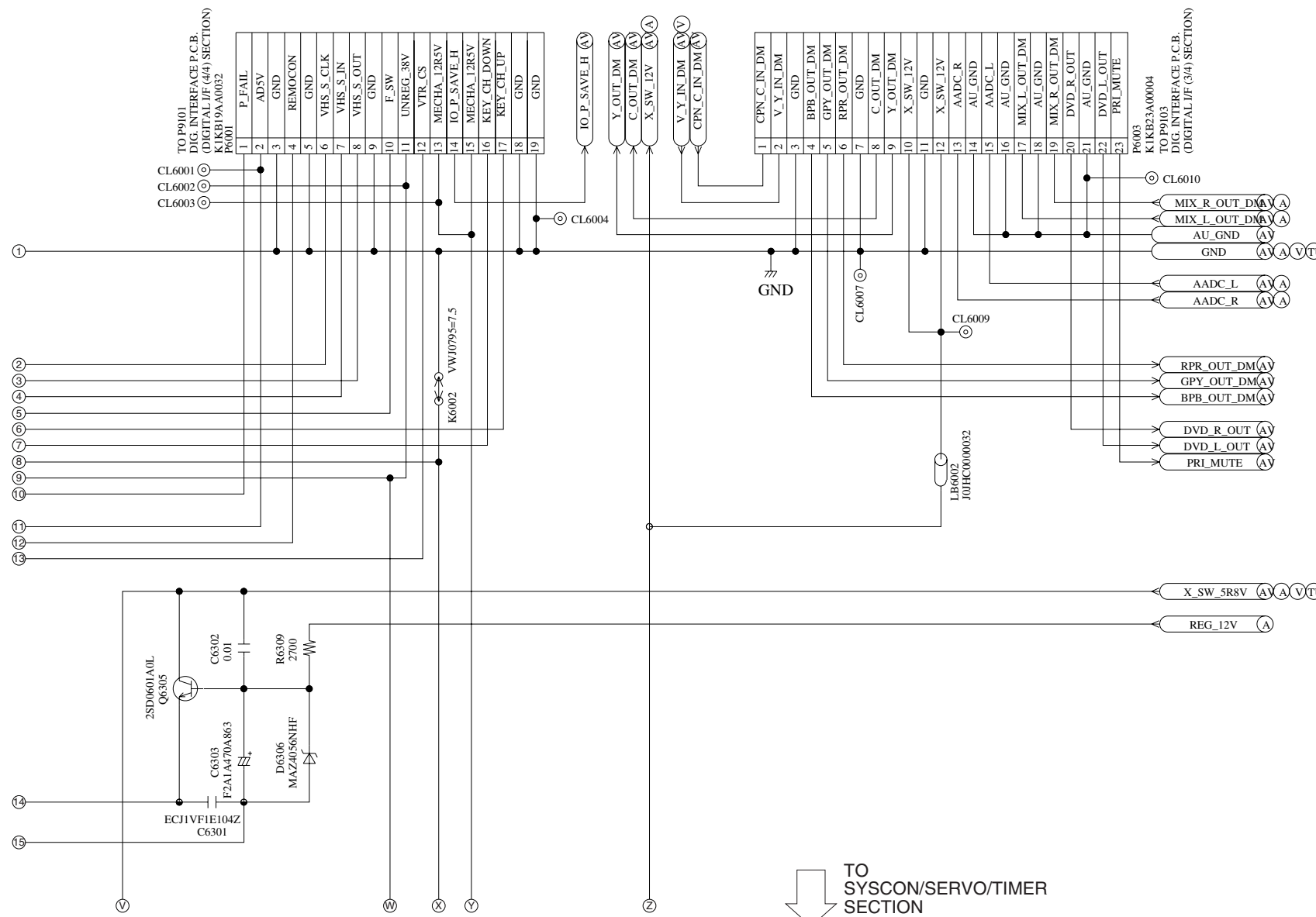

TO  
SYSCON/SERVO/TIMER  
SECTION  
(4/4)

DMR-EX98VEB/EC/EG  
 Syscon/Servo/Timer (2/4) Section  
 (Main P.C.B. (3/5))  
 Schematic Diagram (S)



# 12.12. Syscon/Servo/Timer (4/4) Section (Main P.C.B. (3/5)) Schematic Diagram (S)

E

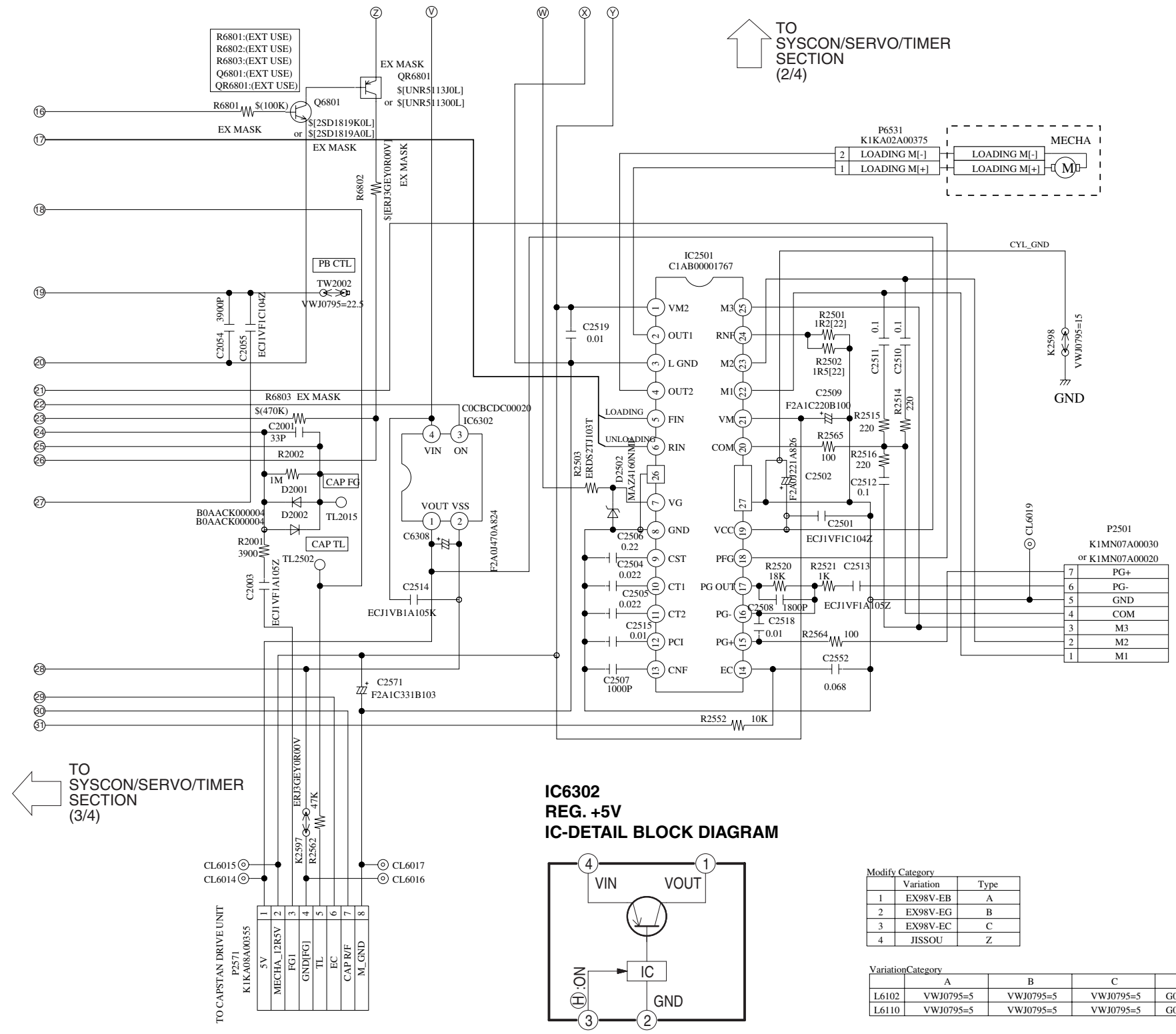

LOCATION MAP

1/4	2/4
3/4	4/4

V:Video Section (Page: **C**)  
 A:VHS Audio Section (Page: **D**)  
 S:Syscon/Servo/Timer Section (Page: **E**)  
 AV:I/O Section (Page: **F**)  
 TU:Tuner Section (Page: **G**)

NOTE:PARTS INDICATED WITH "S" MARK ARE NOT MOUNTED.  
 NOTE:DO NOT USE THE PART NUMBER SHOWN ON THIS DRAWING FOR ORDERING.  
 THE CORRECT PART NUMBER IS SHOWN IN THE PARTS LIST AND MAY BE SLIGHTLYDIFFERENT OR AMENDED SINCE THIS DRAWING WAS PREPARED.

**IC2501  
 LOADING/CYLINDER MOTOR DRIVE  
 IC-DETAIL BLOCK DIAGRAM**

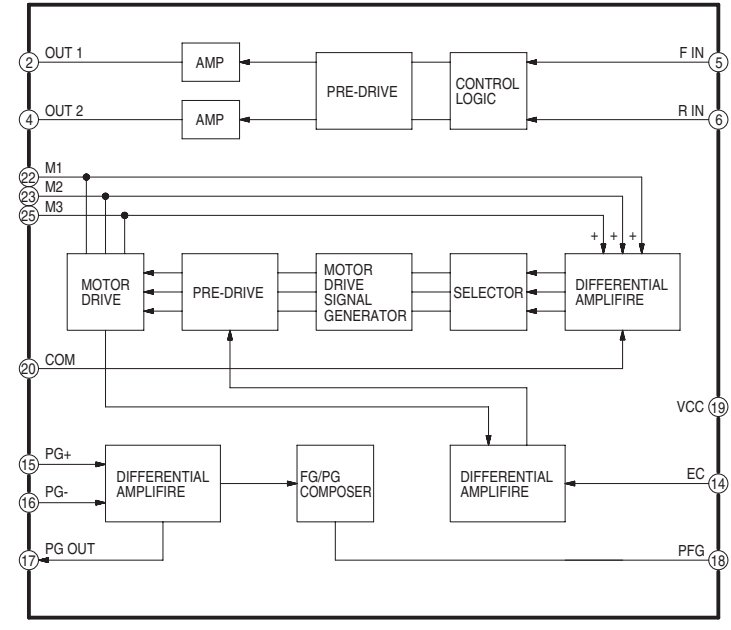

**IC6302  
 REG. +5V  
 IC-DETAIL BLOCK DIAGRAM**

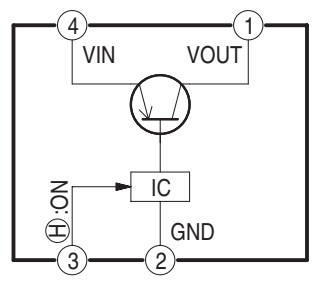

Modify Category

Variation	Type
1 EX98V-EB	A
2 EX98V-EG	B
3 EX98V-EC	C
4 JISSOU	Z

Variation Category

Category	A	B	C	Z
L6102	VWJ0795=5	VWJ0795=5	VWJ0795=5	G0C2R2JA0019
L6110	VWJ0795=5	VWJ0795=5	VWJ0795=5	G0C680JA0019

DMR-EX98VEB/EC/EG  
 Syscon/Servo/Timer (4/4) Section  
 (Main P.C.B. (3/5))  
 Schematic Diagram (S)

### 12.13. I/O Section (1/4) (Main P.C.B. (4/5)) Schematic Diagram (AV)

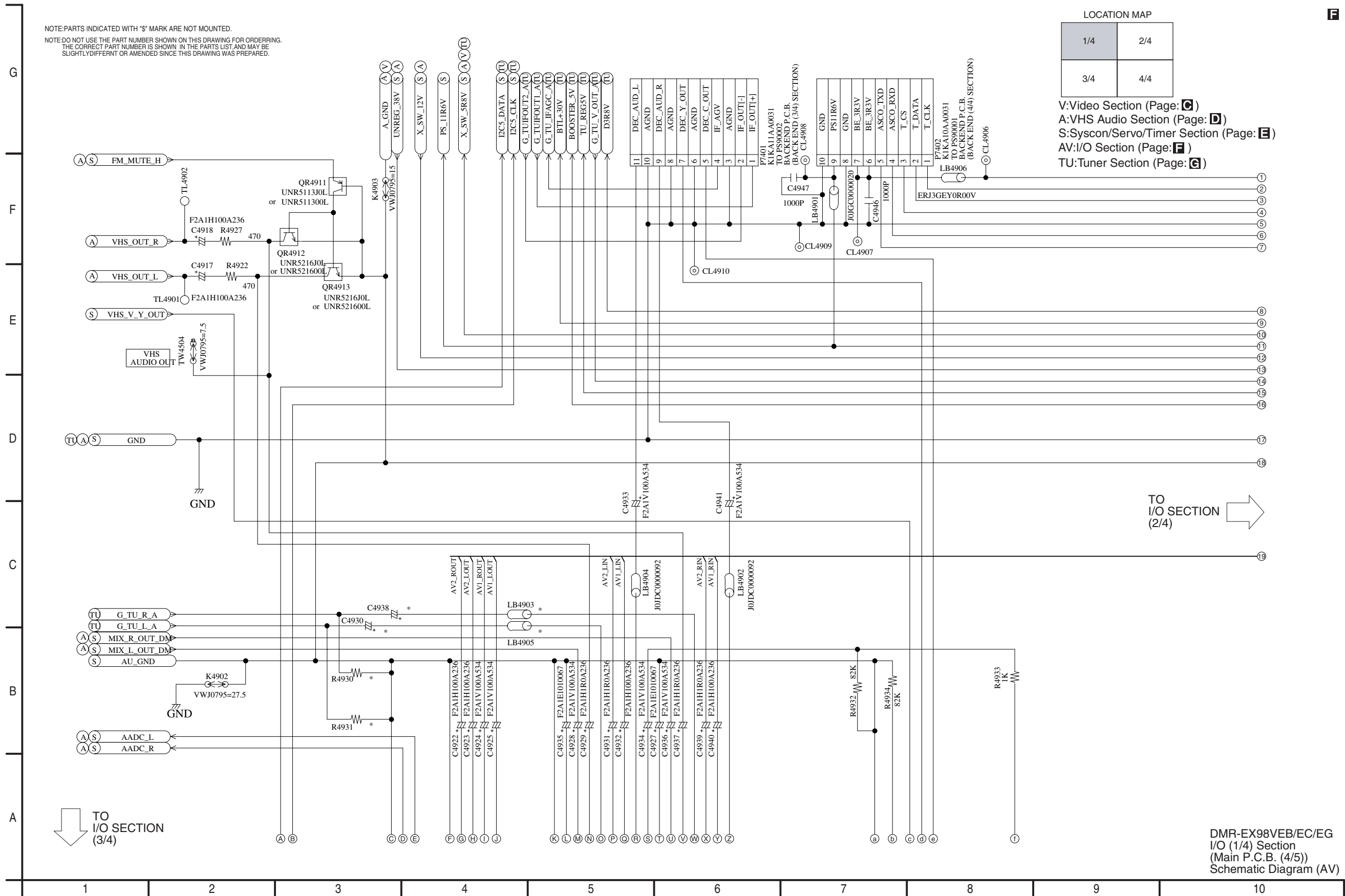

# 12.14. I/O Section (2/4) (Main P.C.B. (4/5)) Schematic Diagram (AV)

F

Variation	Category	A	B	C	Z
C3912		F2A0J101A167	F2A0J101A167	F2A0J101A167	F2A0J221A826
C3929		F2A0J101A167	F2A0J101A167	F2A0J101A167	F2A0J221A826
C4930	\$	F2A1H1R0A236	F2A1H1R0A236	F2A1H1R0A236	F2A1H1R0A236
C4938	\$	F2A1H1R0A236	F2A1H1R0A236	F2A1H1R0A236	F2A1H1R0A236
K3904	\$	ERJ3GEY0R00V	ERJ3GEY0R00V	ERJ3GEY0R00V	ERJ3GEY0R00V
LB4903	\$	ERJ3GEY0R00V	ERJ3GEY0R00V	ERJ3GEY0R00V	ERJ3GEY0R00V
LB4905	\$	ERJ3GEY0R00V	ERJ3GEY0R00V	ERJ3GEY0R00V	ERJ3GEY0R00V
R4930	\$	(47K)	47K	47K	47K
R4931	\$	(47K)	47K	47K	47K

Modify	Category	Variation	Type
1		EX98V-EB	A
2		EX98V-EG	B
3		EX98V-EC	C
4		JISSOU	Z

NOTE: PARTS INDICATED WITH "\$" MARK ARE NOT MOUNTED.  
 NOTE: DO NOT USE THE PART NUMBER SHOWN ON THIS DRAWING FOR ORDERING. THE CORRECT PART NUMBER IS SHOWN IN THE PARTS LIST AND MAY BE SLIGHTLY DIFFERENT OR AMENDED SINCE THIS DRAWING WAS PREPARED.

LOCATION MAP

1/4	2/4
3/4	4/4

V: Video Section (Page: **C**)  
 A: VHS Audio Section (Page: **D**)  
 S: Syscon/Servo/Timer Section (Page: **E**)  
 AV: I/O Section (Page: **F**)  
 TU: Tuner Section (Page: **G**)

TO I/O SECTION (1/4)

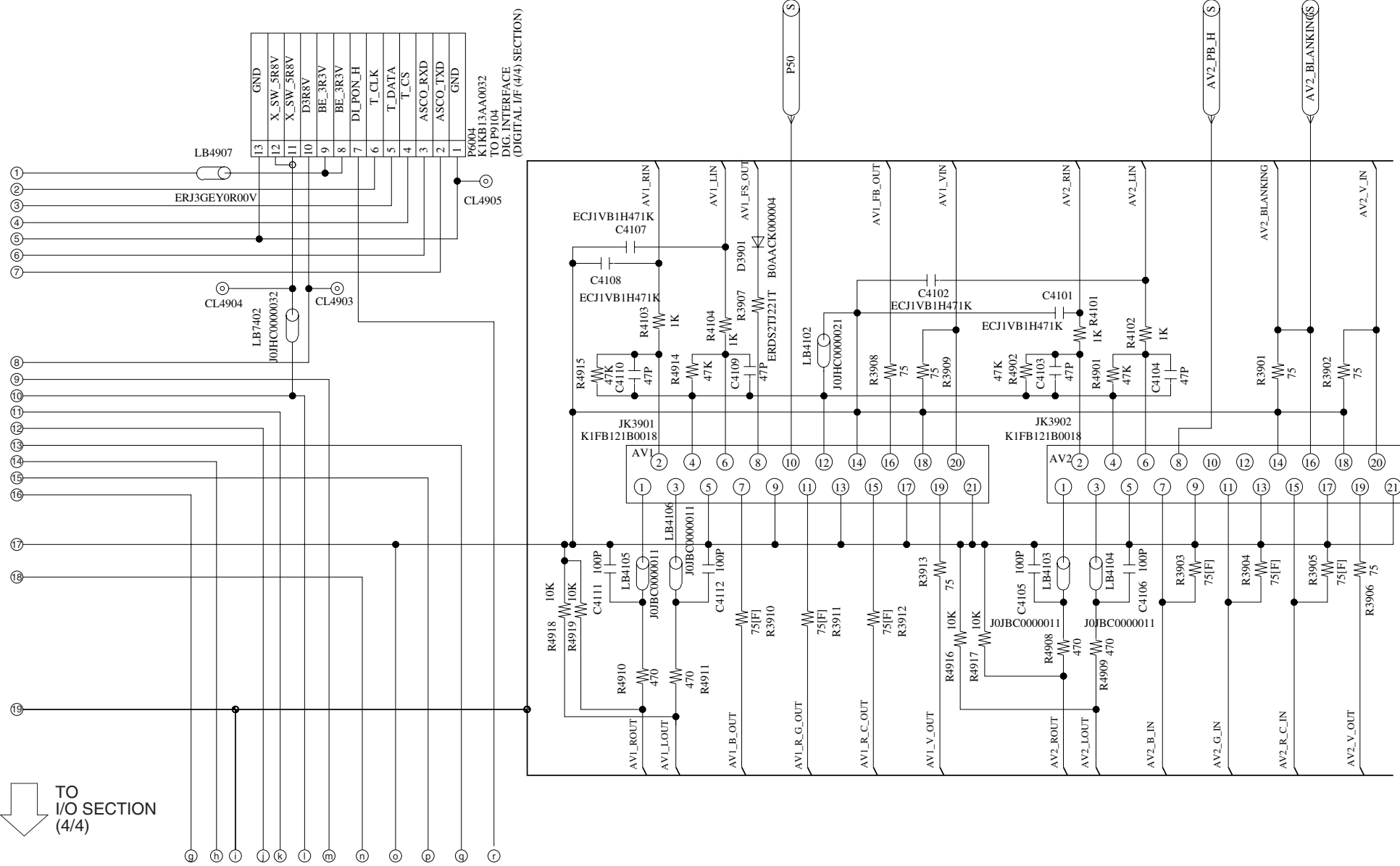

AV1(TV)		AV2(DECODER/EXT)	
1	AUDIO OUT CH2(R)	1	AUDIO OUT CH2(R)
2	AUDIO IN CH2(R)	2	AUDIO IN CH2(R)
3	AUDIO OUT CH1(L)	3	AUDIO OUT CH1(L)
4	GND(A)	4	GND(A)
5	GND(BLUE)	5	GND(BLUE)
6	AUDIO IN CH1(L)	6	AUDIO IN CH1(L)
7	BLUE	7	BLUE
8	PB +12V	8	AV +12V
9	GND(GREEN)	9	GND(GREEN)
10	-/CONTROL	10	-/CONTROL
11	GREEN	11	GREEN
12	-/DATA	12	-/DATA
13	GND(RED)	13	GND(RED)
14	GND(BLANK)	14	GND(BLANK)
15	RED/C OUT	15	RED/C IN
16	BLANKING	16	BLANKING
17	GND(V OUT)	17	GND(V OUT)
18	GND(V IN)	18	GND(V IN)
19	VIDEO OUT/Y OUT	19	VIDEO OUT
20	VIDEO IN	20	VIDEO IN/Y IN
21	GND	21	GND

TO I/O SECTION (4/4)

DMR-EX98VEB/EC/EG  
 I/O (2/4) Section  
 (Main P.C.B. (4/5))  
 Schematic Diagram (AV)

### 12.15. I/O Section (3/4) (Main P.C.B. (4/5)) Schematic Diagram (AV)

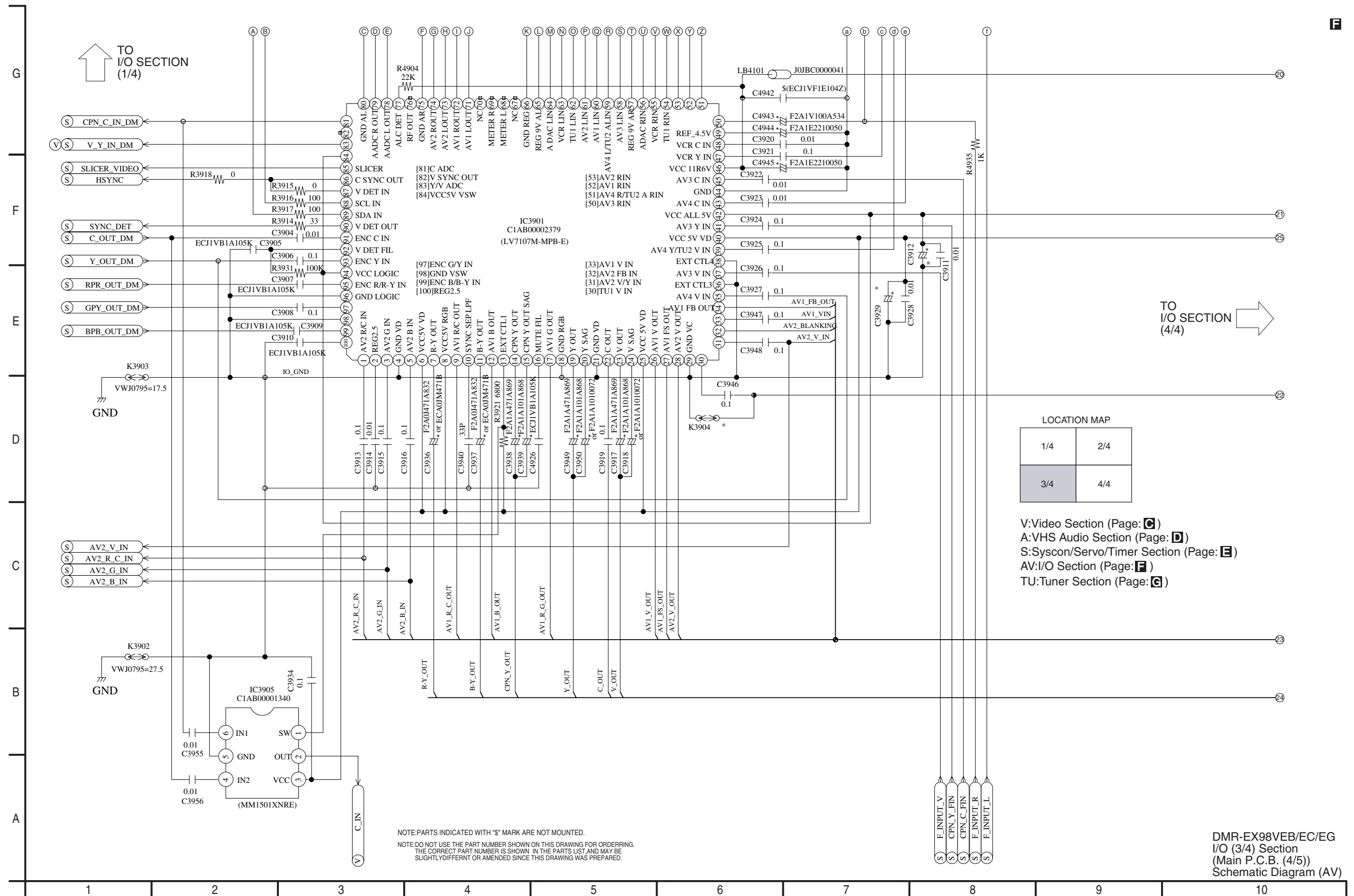

### 12.16. I/O Section (4/4) (Main P.C.B. (4/5)) Schematic Diagram (AV)

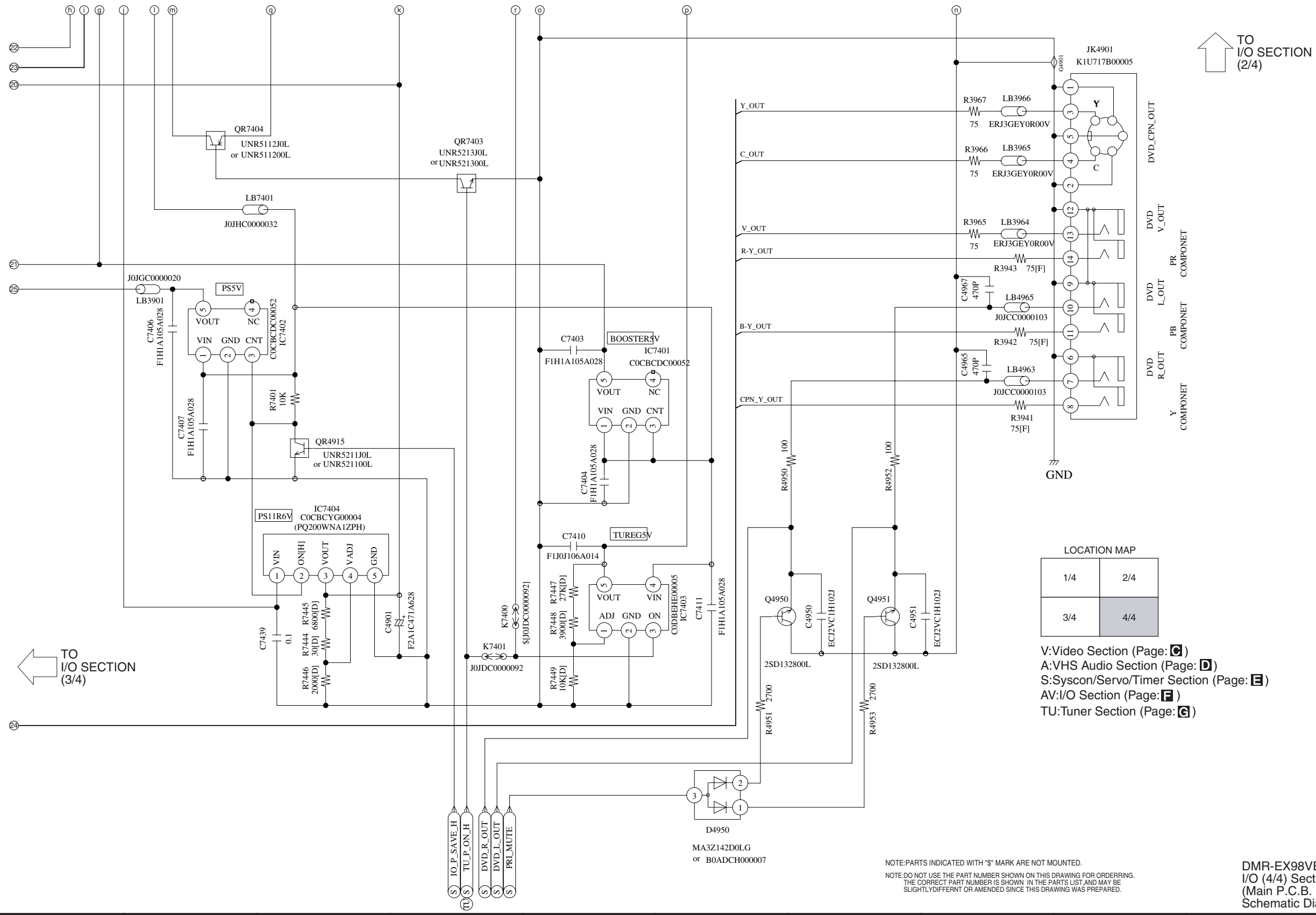

F

TO I/O SECTION (2/4)

TO I/O SECTION (3/4)

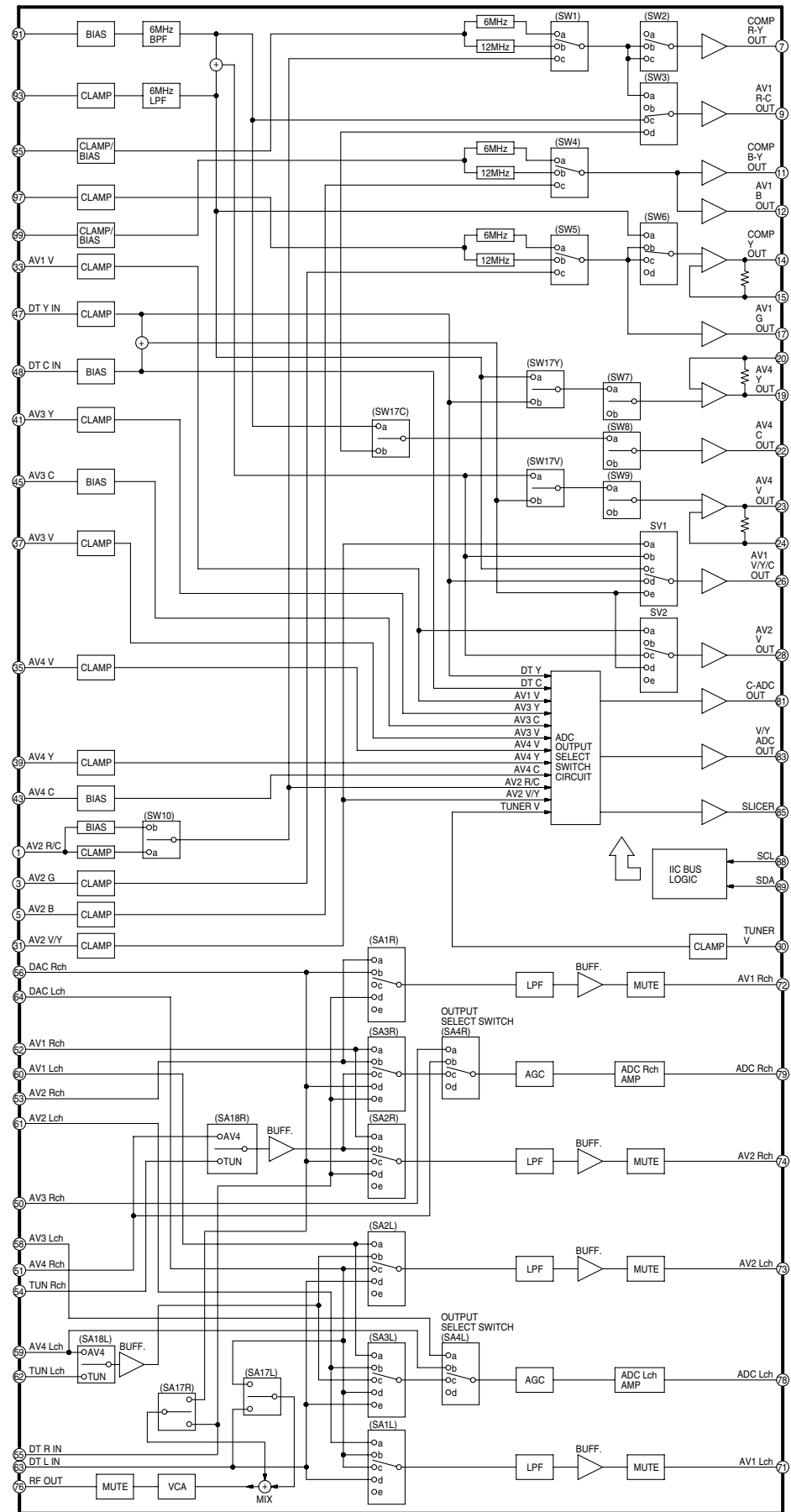

**IC3901  
VIDEO/AUDIO PROCESSOR  
IC-DETAIL BLOCK DIAGRAM**

**IC3905  
SIGNAL SELECT  
IC-DETAIL BLOCK DIAGRAM**

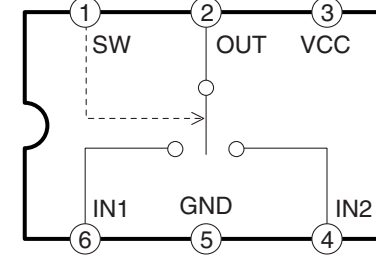

**IC7401,7402  
+5V SWITCHING REGULATOR  
IC-DETAIL BLOCK DIAGRAM**

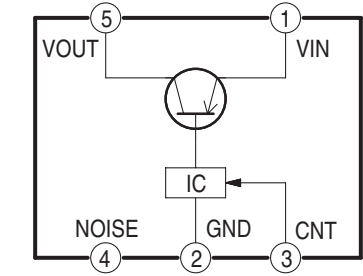

**IC7403  
TU +5V SWITCHING REGULATOR  
IC-DETAIL BLOCK DIAGRAM**

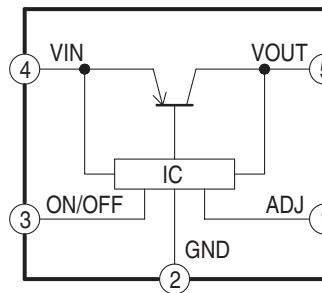

**IC7404  
PS +11.6V SWITCHING REGULATOR  
IC-DETAIL BLOCK DIAGRAM**

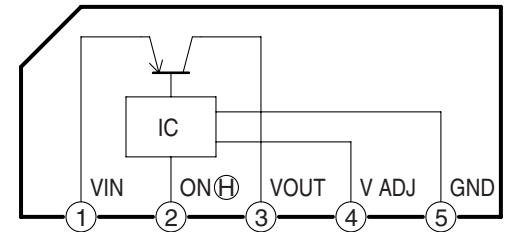

IC3901 Detail Block Diagram  
 IC3905 Detail Block Diagram  
 IC7401 Detail Block Diagram  
 IC7402 Detail Block Diagram  
 IC7403 Detail Block Diagram  
 IC7404 Detail Block Diagram  
 DMR-EX98VEB/EC/EG IC-Detail Block Diagram

# 12.17. Tuner Section (Main P.C.B. (5/5)) Schematic Diagram (TU)

NOTE: PARTS INDICATED WITH "\*" MARK ARE NOT MOUNTED.  
NOTE: DO NOT USE THE PART NUMBER SHOWN ON THIS DRAWING FOR ORDERING.  
THE CORRECT PART NUMBER IS SHOWN IN THE PARTS LIST AND MAY BE SLIGHTLY DIFFERENT OR AMENDED SINCE THIS DRAWING WAS PREPARED.

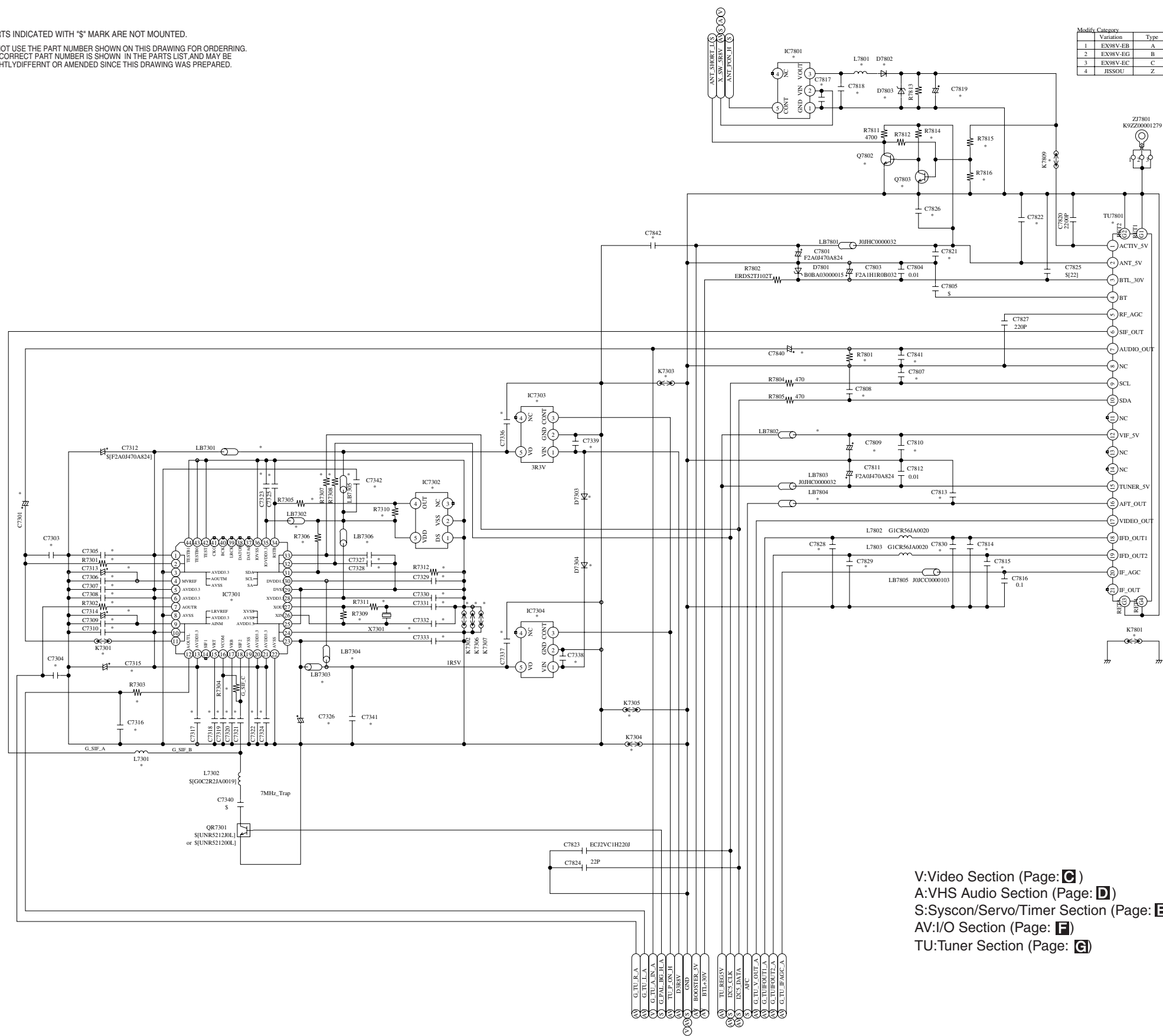

Variation	Type
1 EN98V-EB	A
2 EN98V-EG	B
3 EN98V-EC	C
4 JISSOU	Z

Variation	A	B	C	Z
C7301	S	F2A1C100A234	F2A1C100A234	F2A1C100A234
C7303	S	4700P	4700P	4700P
C7304	S	4700P	4700P	4700P
C7305	S	0.1	0.1	0.1
C7306	S	0.1	0.1	0.1
C7307	S	0.1	0.1	0.1
C7308	S	0.1	0.1	0.1
C7309	S	0.1	0.1	0.1
C7310	S	0.1	0.1	0.1
C7313	S	F2A0470A824	F2A0470A824	F2A0470A824
C7314	S	F2A0470A824	F2A0470A824	F2A0470A824
C7315	S	F2A0470A824	F2A0470A824	F2A0470A824
C7316	S	4700P	4700P	4700P
C7317	S	0.1	0.1	0.1
C7318	S	0.1	0.1	0.1
C7319	S	0.1	0.1	0.1
C7320	S	0.1	0.1	0.1
C7321	S	0.1	0.1	0.1
C7322	S	0.1	0.1	0.1
C7323	S	0.1	0.1	0.1
C7324	S	0.1	0.1	0.1
C7325	S	330P	330P	330P
C7326	S	F2A0470A824	F2A0470A824	F2A0470A824
C7327	S	10P	10P	10P
C7328	S	10P	10P	10P
C7329	S	0.1	0.1	0.1
C7330	S	0.1	0.1	0.1
C7331	S	27P	27P	27P
C7332	S	27P	27P	27P
C7333	S	0.1	0.1	0.1
C7336	S	1u	1u	1u
C7337	S	1u	1u	1u
C7338	S	1u	1u	1u
C7339	S	1u	1u	1u
C7341	S	S	S	0.01
C7342	S	S	S	0.1
C7807	10P	S	S	33P
C7808	10P	S	S	33P
C7809	S	F2A0470A824	F2A0470A824	F2A0470A824
C7810	S	0.01	0.01	0.01
C7813	S	2200P	2200P	2200P
C7814	S	39P	S	39P
C7815	39P	68P	68P	39P
C7817	S	0.1	S	0.1
C7818	S	0.1	S	0.1
C7819	S	F2A0470A824	S	F2A0470A824
C7821	270P	0.01	0.01	0.01
C7822	S	ECJ2VCH220J	ECJ2VCH220J	ECJ2VCH220J
C7826	2200P	S	S	2200P
C7828	S	S	S	68P
C7829	S	S	S	68P
C7830	S	68P	68P	68P
C7840	S	S	S	F2A1C100A234
C7841	S	100P	100P	100P
C7842	S	0.01	0.01	0.01
D7303	S	MA22D3900L	MA22D3900L	MA22D3900L
D7304	S	MA22D3900L	MA22D3900L	MA22D3900L
D7802	S	MA2C72300F	S	MA2C72300F
D7803	S	MAZ405INMF	S	MAZ405INMF
IC7801	S	C1A80002845	C1A80002844	C1A80002844
IC7802	S	COE8E000366	COE8E000366	COE8E000366
IC7803	S	COE8E000366	COE8E000366	COE8E000366
IC7804	S	COE8E000366	COE8E000366	COE8E000366
IC7805	S	COE8E000366	COE8E000366	COE8E000366
IC7806	S	COE8E000366	COE8E000366	COE8E000366
IC7807	S	COE8E000366	COE8E000366	COE8E000366
IC7808	S	COE8E000366	COE8E000366	COE8E000366
IC7809	S	COE8E000366	COE8E000366	COE8E000366
IC7810	S	COE8E000366	COE8E000366	COE8E000366
IC7811	S	COE8E000366	COE8E000366	COE8E000366
IC7812	S	COE8E000366	COE8E000366	COE8E000366
IC7813	S	COE8E000366	COE8E000366	COE8E000366
IC7814	S	COE8E000366	COE8E000366	COE8E000366
IC7815	S	COE8E000366	COE8E000366	COE8E000366
IC7816	S	COE8E000366	COE8E000366	COE8E000366
IC7817	S	COE8E000366	COE8E000366	COE8E000366
IC7818	S	COE8E000366	COE8E000366	COE8E000366
IC7819	S	COE8E000366	COE8E000366	COE8E000366
IC7820	S	COE8E000366	COE8E000366	COE8E000366
IC7821	S	COE8E000366	COE8E000366	COE8E000366
IC7822	S	COE8E000366	COE8E000366	COE8E000366
IC7823	S	COE8E000366	COE8E000366	COE8E000366
IC7824	S	COE8E000366	COE8E000366	COE8E000366
IC7825	S	COE8E000366	COE8E000366	COE8E000366
IC7826	S	COE8E000366	COE8E000366	COE8E000366
IC7827	S	COE8E000366	COE8E000366	COE8E000366
IC7828	S	COE8E000366	COE8E000366	COE8E000366
IC7829	S	COE8E000366	COE8E000366	COE8E000366
IC7830	S	COE8E000366	COE8E000366	COE8E000366
IC7831	S	COE8E000366	COE8E000366	COE8E000366
IC7832	S	COE8E000366	COE8E000366	COE8E000366
IC7833	S	COE8E000366	COE8E000366	COE8E000366
IC7834	S	COE8E000366	COE8E000366	COE8E000366
IC7835	S	COE8E000366	COE8E000366	COE8E000366
IC7836	S	COE8E000366	COE8E000366	COE8E000366
IC7837	S	COE8E000366	COE8E000366	COE8E000366
IC7838	S	COE8E000366	COE8E000366	COE8E000366
IC7839	S	COE8E000366	COE8E000366	COE8E000366
IC7840	S	COE8E000366	COE8E000366	COE8E000366
IC7841	S	COE8E000366	COE8E000366	COE8E000366
IC7842	S	COE8E000366	COE8E000366	COE8E000366
IC7843	S	COE8E000366	COE8E000366	COE8E000366
IC7844	S	COE8E000366	COE8E000366	COE8E000366
IC7845	S	COE8E000366	COE8E000366	COE8E000366
IC7846	S	COE8E000366	COE8E000366	COE8E000366
IC7847	S	COE8E000366	COE8E000366	COE8E000366
IC7848	S	COE8E000366	COE8E000366	COE8E000366
IC7849	S	COE8E000366	COE8E000366	COE8E000366
IC7850	S	COE8E000366	COE8E000366	COE8E000366
IC7851	S	COE8E000366	COE8E000366	COE8E000366
IC7852	S	COE8E000366	COE8E000366	COE8E000366
IC7853	S	COE8E000366	COE8E000366	COE8E000366
IC7854	S	COE8E000366	COE8E000366	COE8E000366
IC7855	S	COE8E000366	COE8E000366	COE8E000366
IC7856	S	COE8E000366	COE8E000366	COE8E000366
IC7857	S	COE8E000366	COE8E000366	COE8E000366
IC7858	S	COE8E000366	COE8E000366	COE8E000366
IC7859	S	COE8E000366	COE8E000366	COE8E000366
IC7860	S	COE8E000366	COE8E000366	COE8E000366
IC7861	S	COE8E000366	COE8E000366	COE8E000366
IC7862	S	COE8E000366	COE8E000366	COE8E000366
IC7863	S	COE8E000366	COE8E000366	COE8E000366
IC7864	S	COE8E000366	COE8E000366	COE8E000366
IC7865	S	COE8E000366	COE8E000366	COE8E000366
IC7866	S	COE8E000366	COE8E000366	COE8E000366
IC7867	S	COE8E000366	COE8E000366	COE8E000366
IC7868	S	COE8E000366	COE8E000366	COE8E000366
IC7869	S	COE8E000366	COE8E000366	COE8E000366
IC7870	S	COE8E000366	COE8E000366	COE8E000366
IC7871	S	COE8E000366	COE8E000366	COE8E000366
IC7872	S	COE8E000366	COE8E000366	COE8E000366
IC7873	S	COE8E000366	COE8E000366	COE8E000366
IC7874	S	COE8E000366	COE8E000366	COE8E000366
IC7875	S	COE8E000366	COE8E000366	COE8E000366
IC7876	S	COE8E000366	COE8E000366	COE8E000366
IC7877	S	COE8E000366	COE8E000366	COE8E000366
IC7878	S	COE8E000366	COE8E000366	COE8E000366
IC7879	S	COE8E000366	COE8E000366	COE8E000366
IC7880	S	COE8E000366	COE8E000366	COE8E000366
IC7881	S	COE8E000366	COE8E000366	COE8E000366
IC7882	S	COE8E000366	COE8E000366	COE8E000366
IC7883	S	COE8E000366	COE8E000366	COE8E000366
IC7884	S	COE8E000366	COE8E000366	COE8E000366
IC7885	S	COE8E000366	COE8E000366	COE8E000366
IC7886	S	COE8E000366	COE8E000366	COE8E000366
IC7887	S	COE8E000366	COE8E000366	COE8E000366
IC7888	S	COE8E000366	COE8E000366	COE8E000366
IC7889	S	COE8E000366	COE8E000366	COE8E000366
IC7890	S	COE8E000366	COE8E000366	COE8E000366
IC7891	S	COE8E000366	COE8E000366	COE8E000366
IC7892	S	COE8E000366	COE8E000366	COE8E000366
IC7893	S	COE8E000366	COE8E000366	COE8E000366
IC7894	S	COE8E000366	COE8E000366	COE8E000366
IC7895	S	COE8E000366	COE8E000366	COE8E000366
IC7896	S	COE8E000366	COE8E000366	COE8E000366
IC7897	S	COE8E000366	COE8E000366	COE8E000366
IC7898	S	COE8E000366	COE8E000366	COE8E000366
IC7899	S	COE8E000366	COE8E000366	COE8E000366
IC7900	S	COE8E000366	COE8E000366	COE8E000366
IC7901	S	COE8E000366	COE8E000366	COE8E000366
IC7902	S	COE8E000366	COE8E000366	COE8E000366
IC7903	S	COE8E000366	COE8E000366	COE8E000366
IC7904	S	COE8E000366	COE8E000366	COE8E000366
IC7905	S	COE8E000366	COE8E000366	COE8E000366
IC7906	S	COE8E000366	COE8E000366	COE8E000366
IC7907	S	COE8E000366	COE8E000366	COE8E000366
IC7908	S	COE8E000366	COE8E000366	COE8E000366
IC7909	S	COE8E000366	COE8E000366	COE8E000366
IC7910	S	COE8E000366	COE8E000366	COE8E000366
IC7911	S	COE8E000366	COE8E000366	COE8E000366
IC7912	S	COE8E000366	COE8E000366	COE8E000366
IC7913	S	COE8E000366	COE8E000366	COE8E000366
IC7914	S	COE8E000366	COE8E000366	COE8E000366
IC7915	S	COE8E000366	COE8E000366	COE8E000366
IC7916	S	COE8E000366	COE8E000366	COE8E000366
IC7917	S	COE8E000366	COE8E000366	COE8E000366
IC7918	S	COE8E000366	COE8E000366	COE8E000366
IC7919	S	COE8E000366	COE8E000366	COE8E000366
IC7920	S	COE8E000366	COE8E000366	COE8E000366
IC7921	S	COE8E000366	COE8E000366	COE8E000366
IC7922	S	COE8E000366	COE8E00036	

**IC7301  
DECODER  
IC-DETAIL BLOCK DIAGRAM**

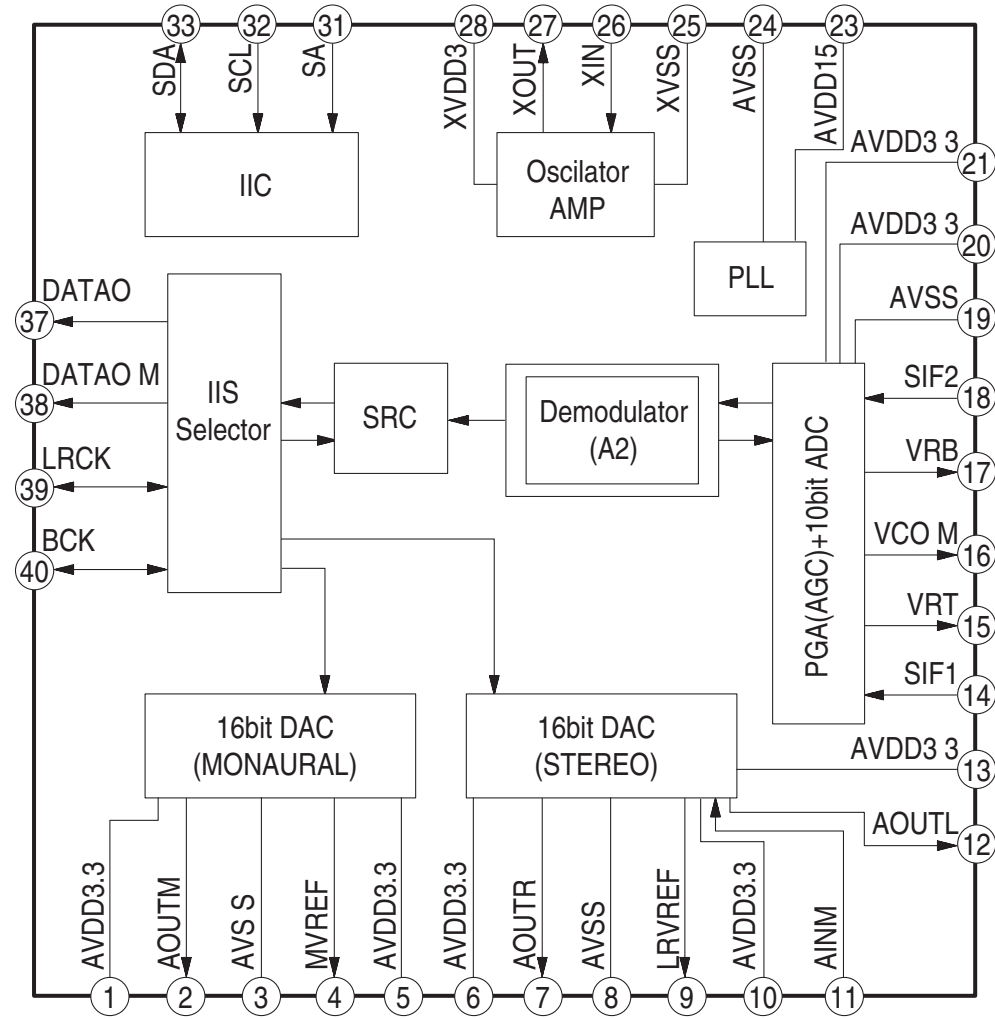

**IC7302  
RESET  
IC-DETAIL BLOCK DIAGRAM**

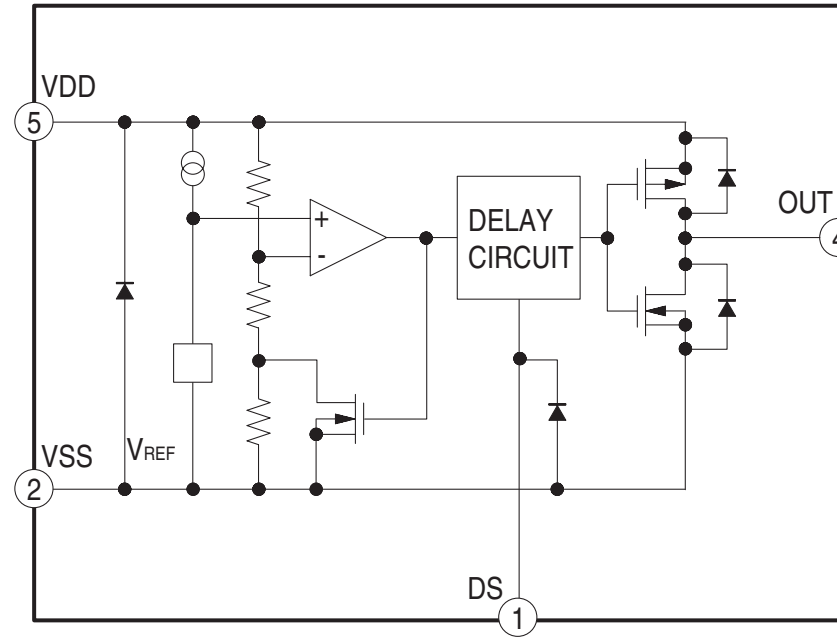

**IC7303  
REG. +3.3V  
IC-DETAIL BLOCK DIAGRAM**

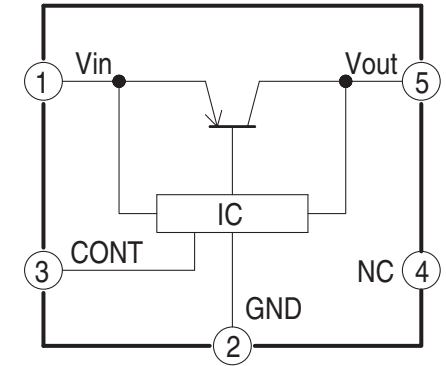

**IC7304  
REG. +1.5V  
IC-DETAIL BLOCK DIAGRAM**

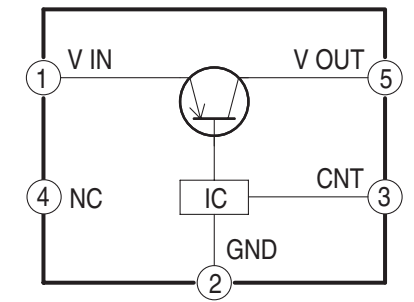

**IC7801  
REG. ACTIV +5V  
IC-DETAIL BLOCK DIAGRAM**

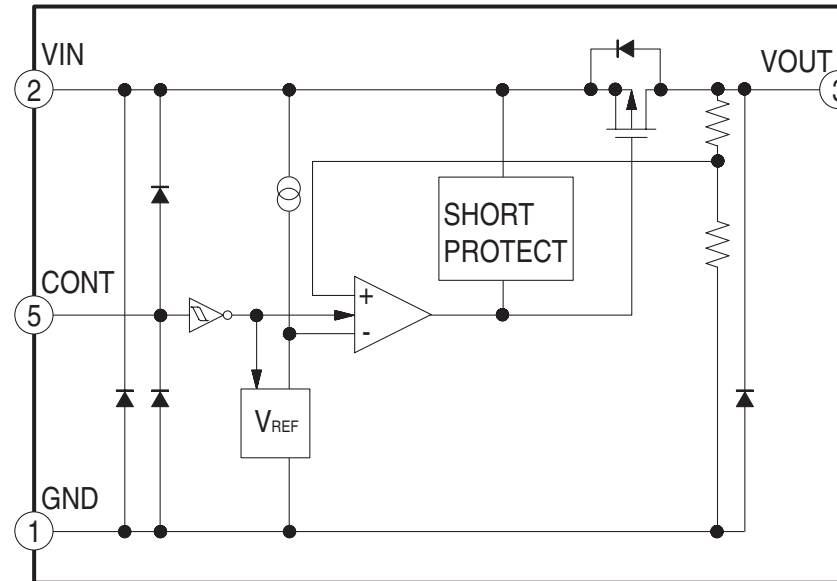

IC7301 Detail Block Diagram  
 IC7302 Detail Block Diagram  
 IC7303 Detail Block Diagram  
 IC7304 Detail Block Diagram  
 IC7801 Detail Block Diagram  
 DMR-EX98VEB/EC/EG IC-Detail Block Diagram

# 12.18. HDMI Schematic Diagram

G  
F  
E  
D  
C  
B  
A

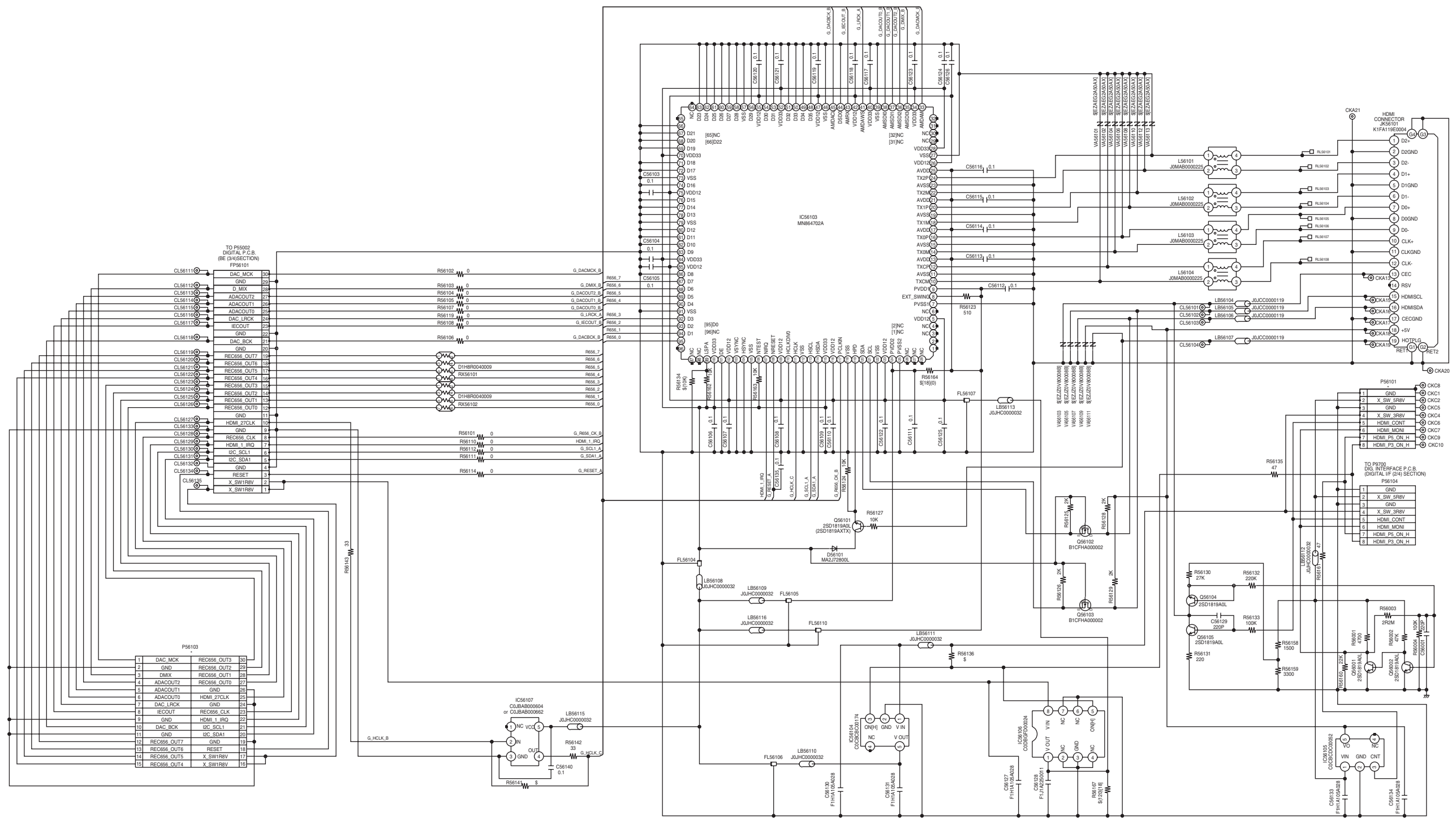

P56103

1	DAC_MCK	REC656_OUT3	30
2	GND	REC656_OUT2	29
3	DMX	REC656_OUT1	28
4	ADACOUT2	REC656_OUT0	27
5	ADACOUT1	GND	26
6	ADACOUT0	HDMI_27CLK	25
7	DAC_LRCK	GND	24
8	IECOUT	REC656_CLK	23
9	GND	HDMI_1_IRQ	22
10	DAC_BCK	IEC_SCL1	21
11	GND	IEC_SDA1	20
12	REC656_OUT7	GND	19
13	REC656_OUT6	RESET	18
14	REC656_OUT5	X_SW1R8V	17
15	REC656_OUT4	X_SW1R8V	16

Modify Category

Variation	Type
1 DMR-EH58, EH58S, EH68, EH68S, EX78, EX81, EX88	A
2 DMR-EZ49V, EX98V	B

Variation Category

A	B
FP56101 \$K1M3DA00202	K1M3DA00202
P56101 K1KB08A00084	\$K1KB08A00084
P56103 K1KC30A00003	\$K1KC30A00003
P56104 \$K1KA08B000261	K1KA08B000261

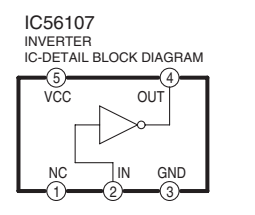
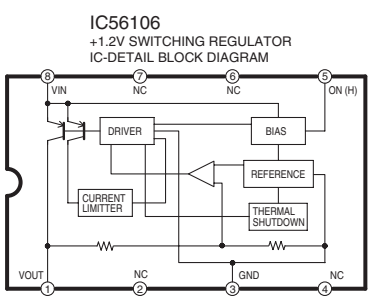
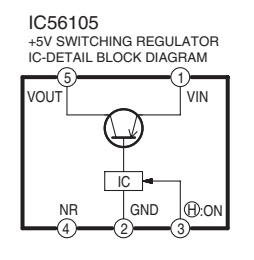
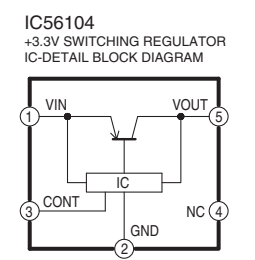

NOTE: PARTS INDICATED WITH "\*" MARK ARE NOT MOUNTED.  
NOTE: DO NOT USE THE PART NUMBER SHOWN ON THIS DRAWING FOR ORDERING. THE CORRECT PART NUMBER IS SHOWN IN THE PARTS LIST AND MAY BE SLIGHTLY DIFFERENT OR AMENDED SINCE THIS DRAWING WAS PREPARED.

DMR-EX98VEB/EC/EG  
HDMI  
Schematic Diagram

### 12.19. FL Drive Schematic Diagram

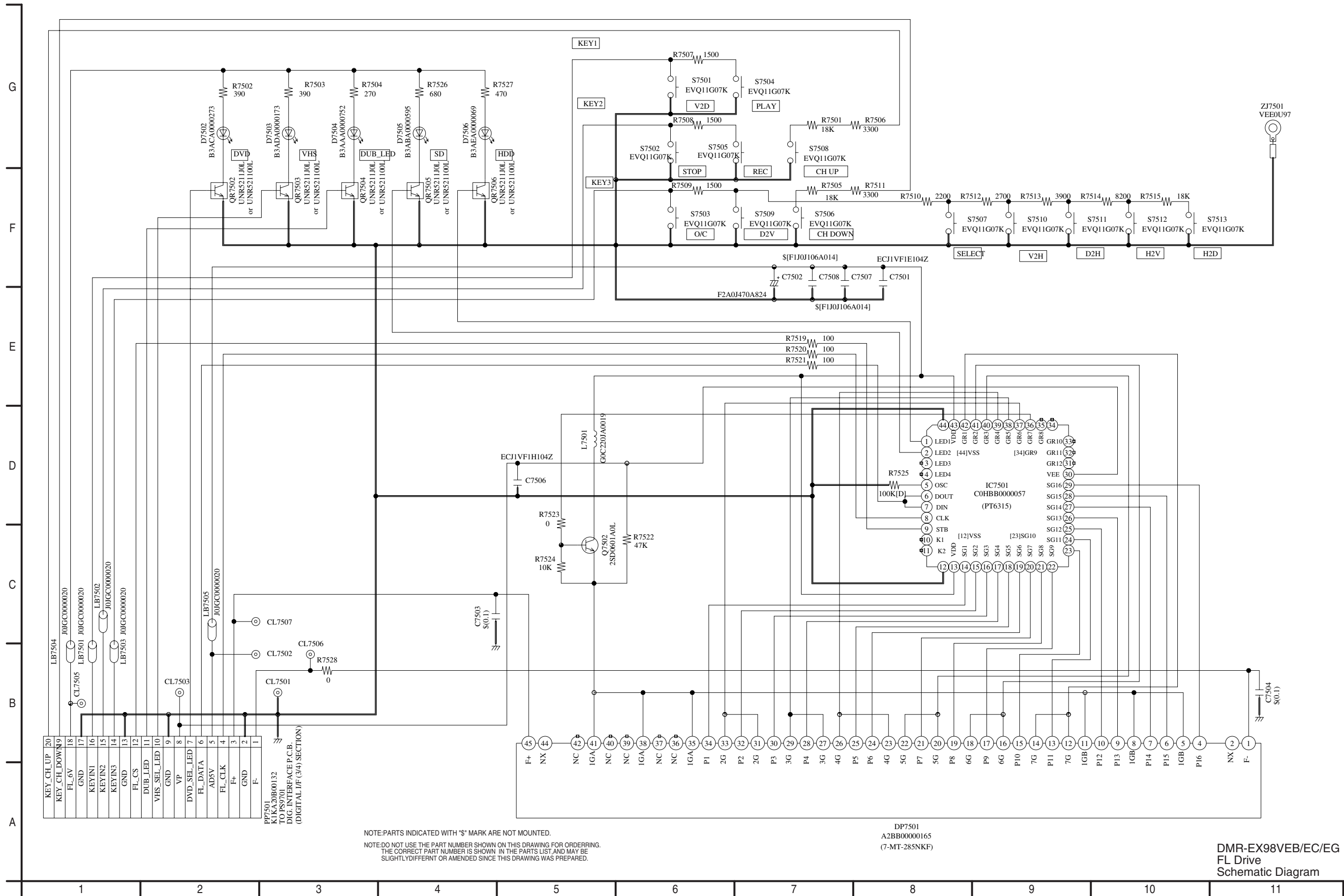

NOTE: PARTS INDICATED WITH \*S\* MARK ARE NOT MOUNTED.  
 NOTE: DO NOT USE THE PART NUMBER SHOWN ON THIS DRAWING FOR ORDERING.  
 THE CORRECT PART NUMBER IS SHOWN IN THE PARTS LIST, AND MAY BE  
 SLIGHTLY DIFFERENT OR AMENDED SINCE THIS DRAWING WAS PREPARED.

DP7501  
 A2BB00000165  
 (7-MT-285NKF)

DMR-EX98VEB/EC/EG  
 FL Drive  
 Schematic Diagram

**IC7501  
FL DISPLAY DRIVER  
IC-DETAIL BLOCK DIAGRAM**

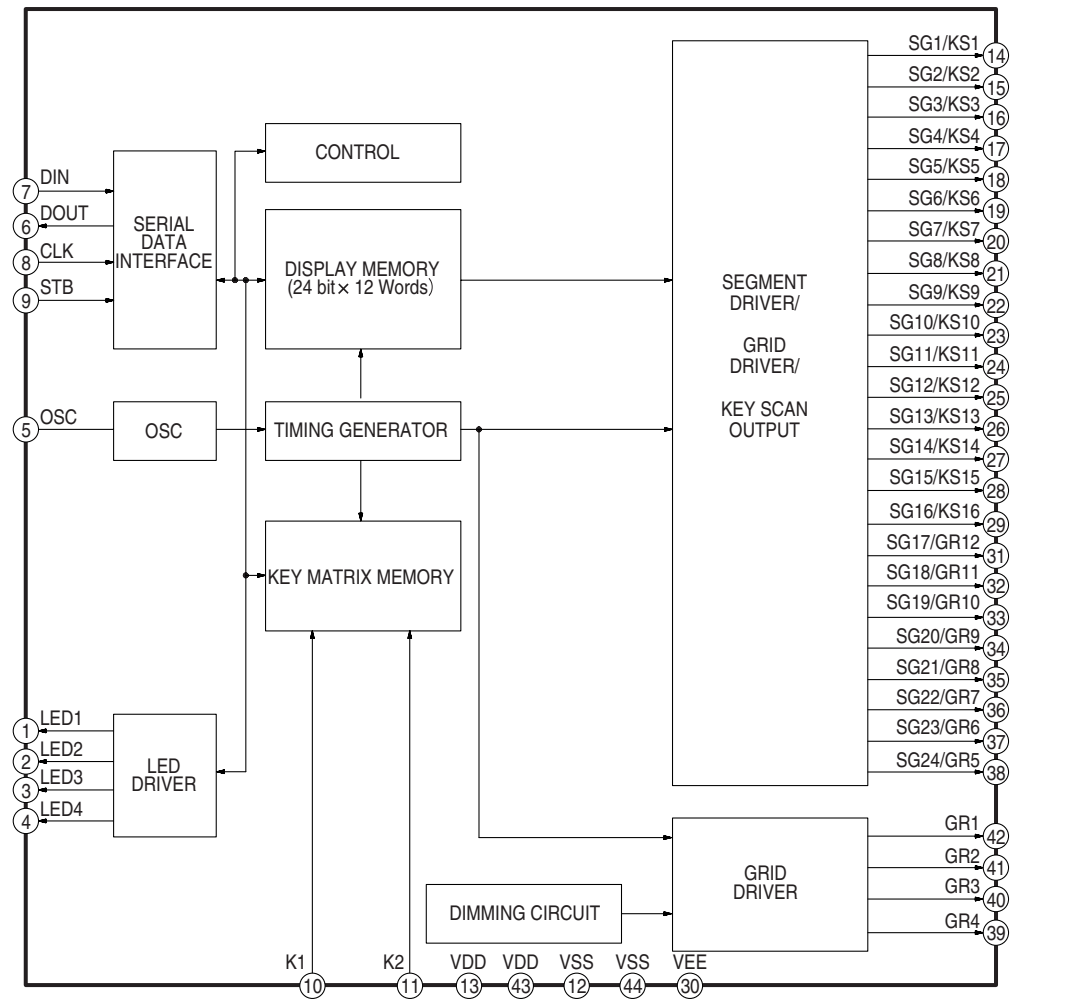

IC7501 Detail Block Diagram  
DMR-EX98VEB/EC/EG IC-Detail Block Diagram

### 12.20. DV/SD/USB Schematic Diagram

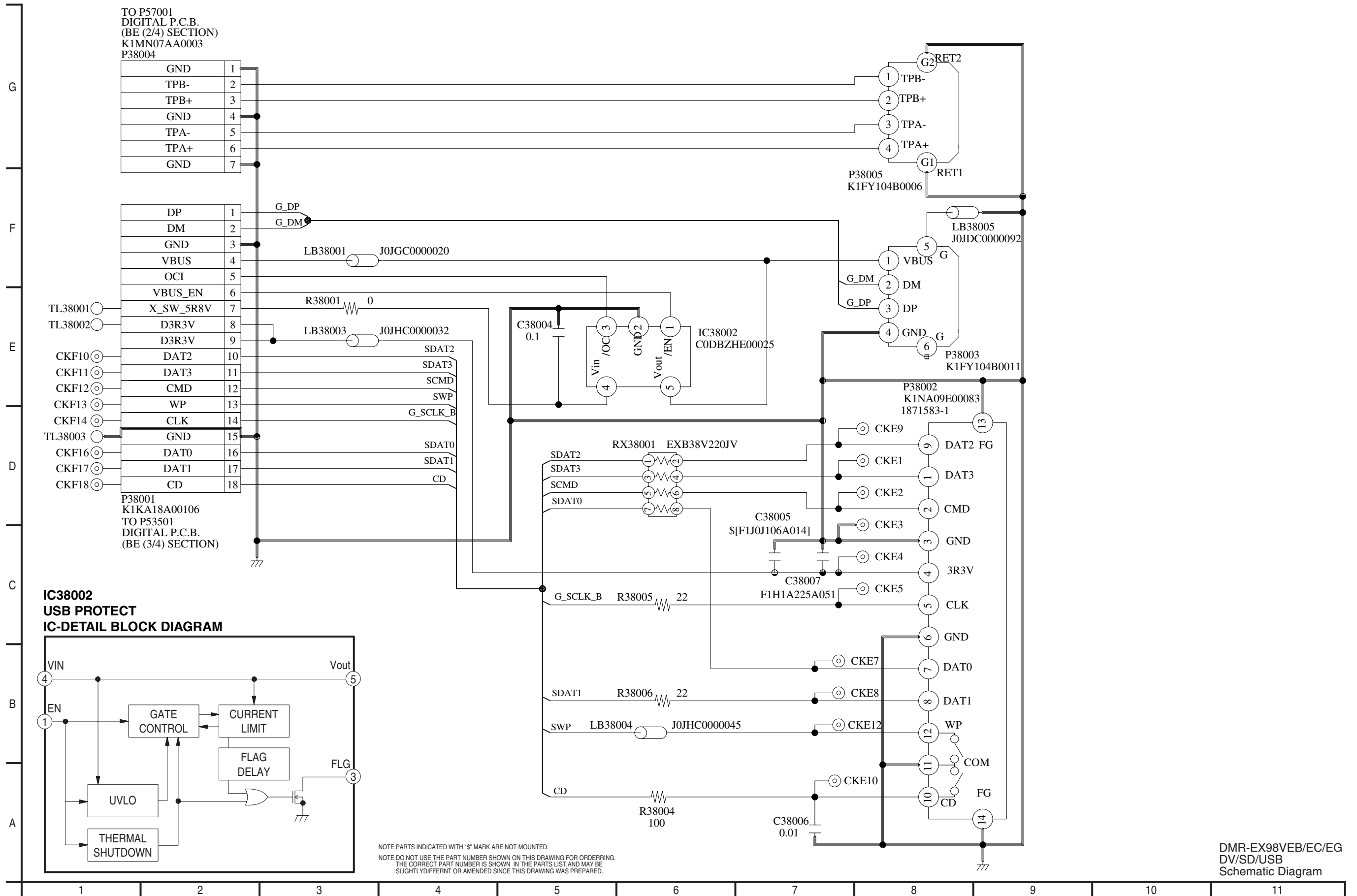

DMR-EX98VEB/EC/EG  
DV/SD/USB  
Schematic Diagram

### 12.21. Front Jack Schematic Diagram

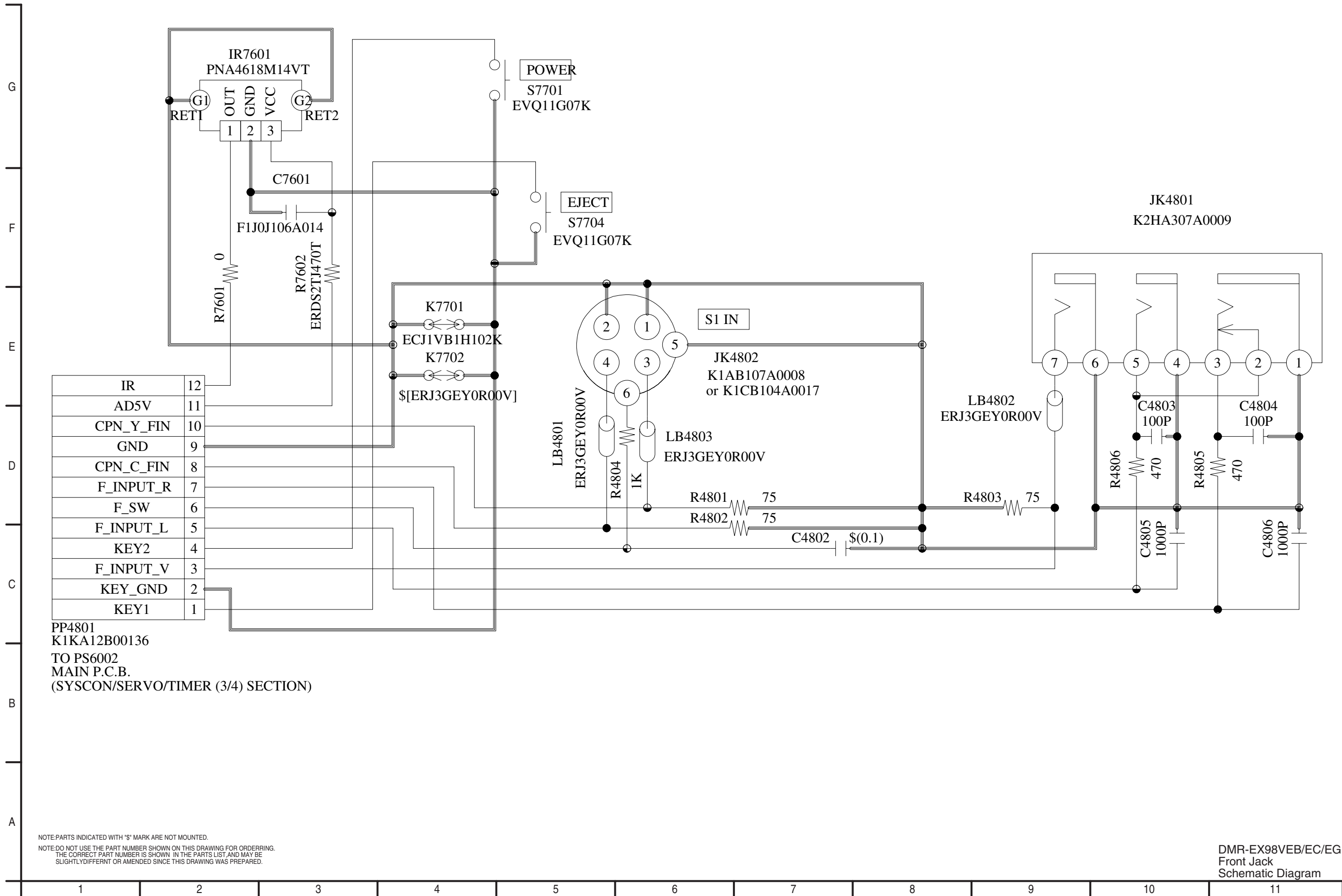

### 12.22. ATAPI Schematic Diagram

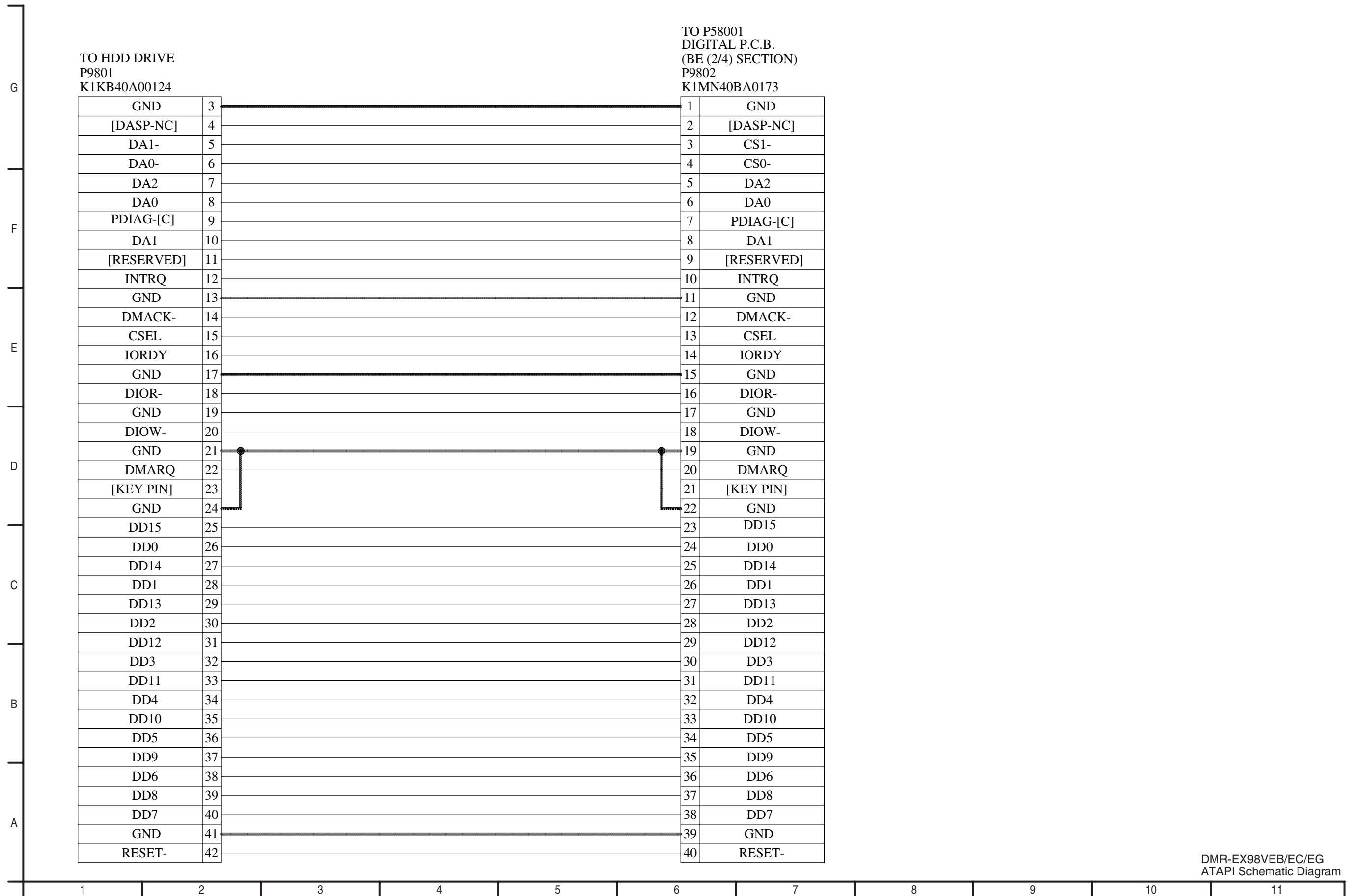



# 13 Printed Circuit Board

## 13.1. Dig. Interface P.C.B.

### 13.1.1. Dig. Interface P.C.B. (1/4 Section)

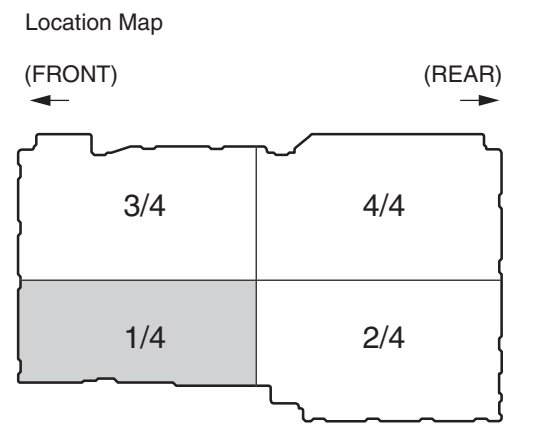
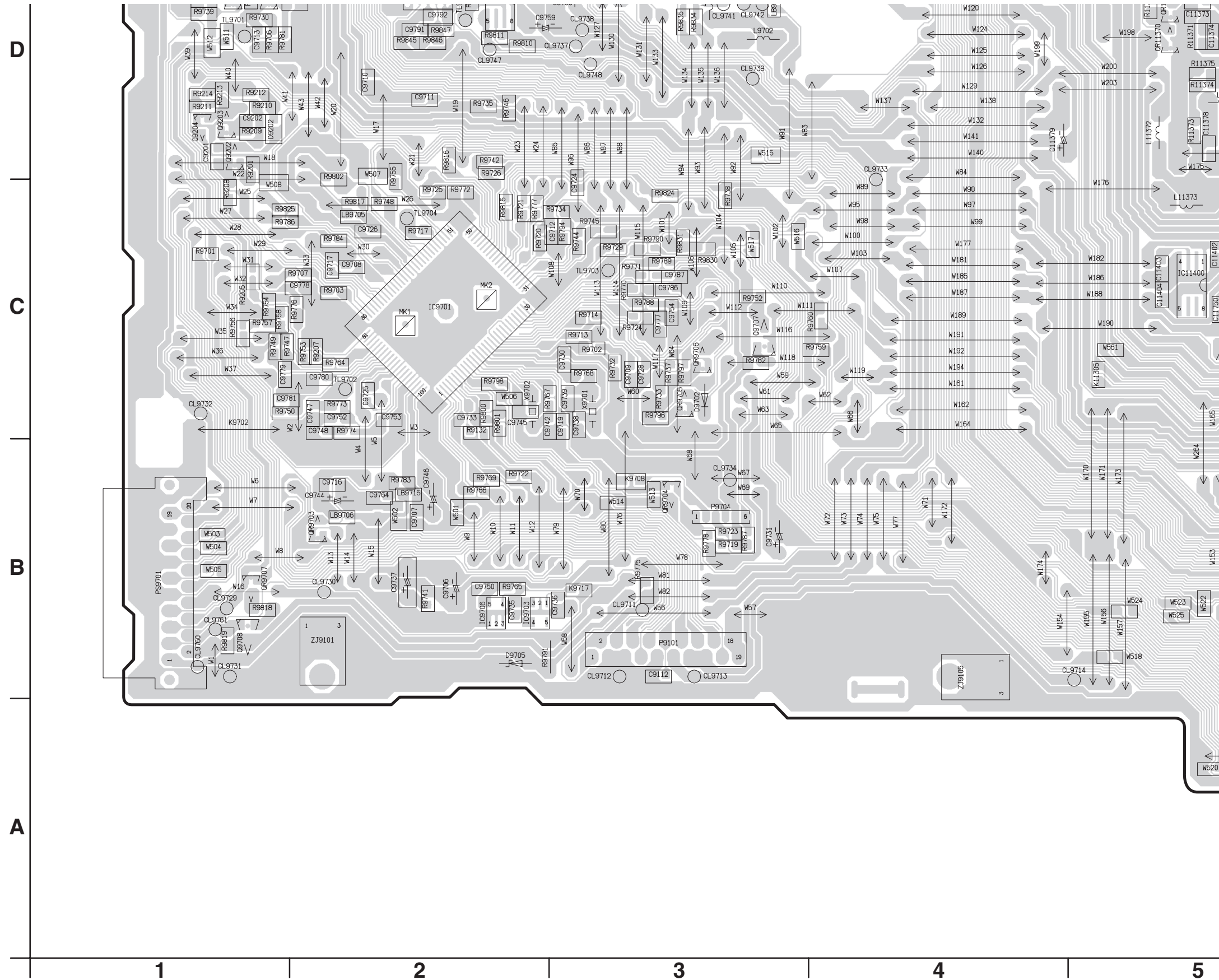

DMR-EX98VEB/EC/EG  
 Dig. Interface P.C.B.  
 (RFKB71134A: EX98VEB,  
 RFKB71134AT: EX98VEC/EG)  
 (1/4 Section)

### 13.1.2. Dig. Interface P.C.B. (2/4 Section)

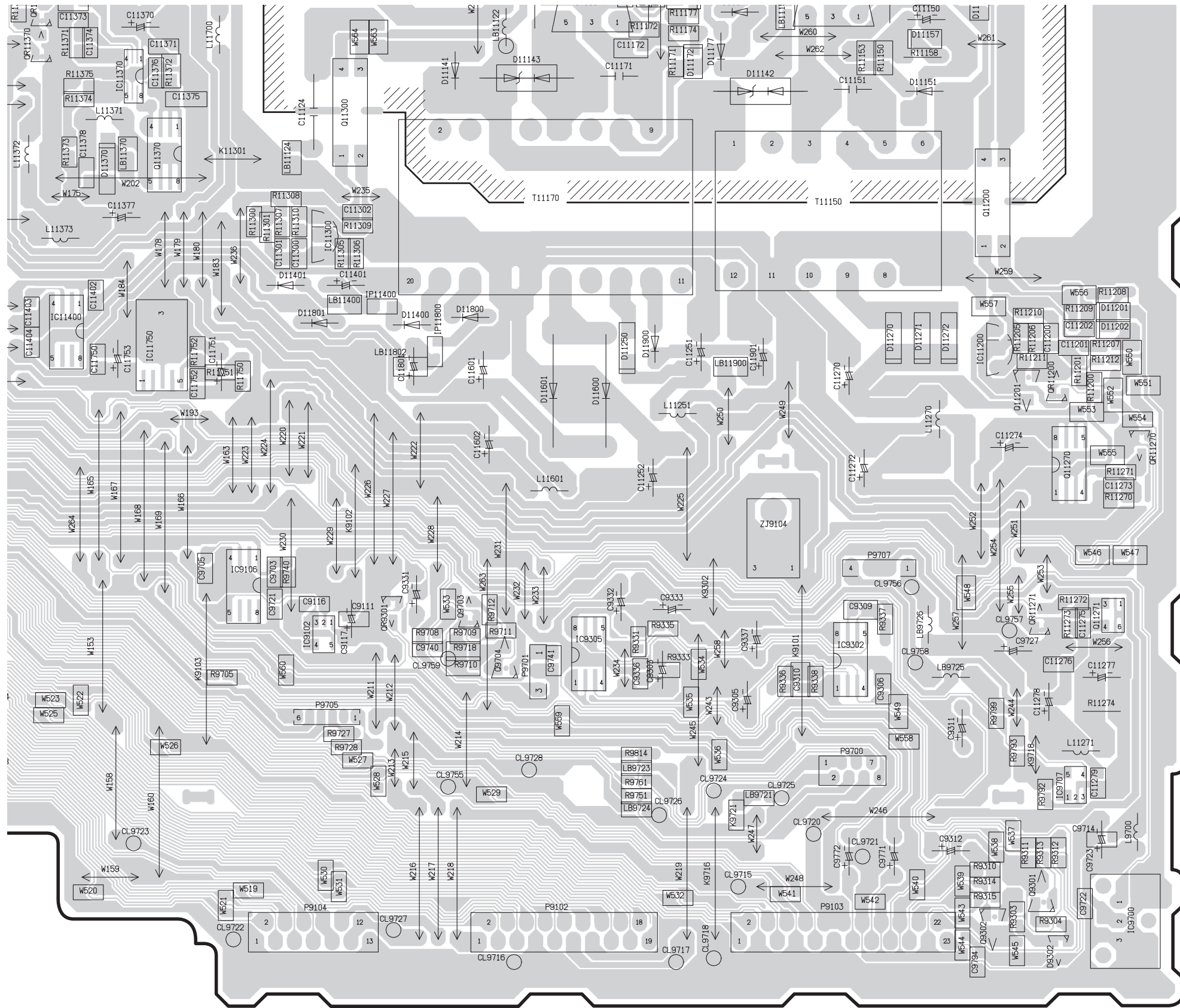

Location Map

(FRONT)

(REAR)

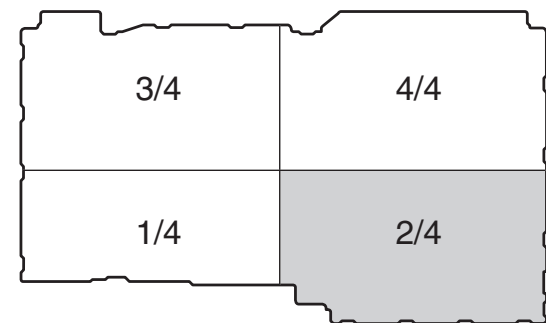

DMR-EX98VEB/EC/EG  
 Dig. Interface P.C.B.  
 (RFKB71134A: EX98VEB,  
 RFKB71134AT: EX98VEC/EG)  
 (2/4 Section)

5

6

7

8

9



13.1.4. Dig. Interface P.C.B. (4/4 Section)

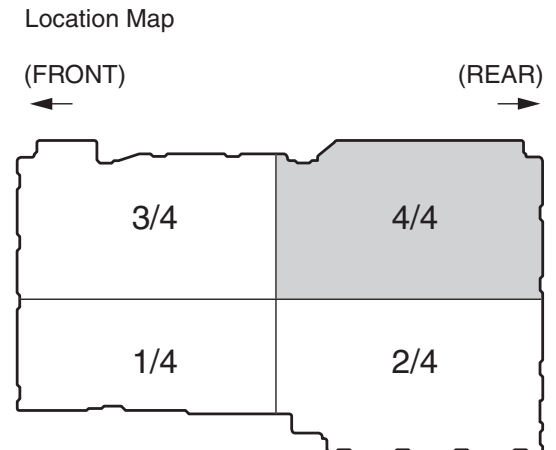
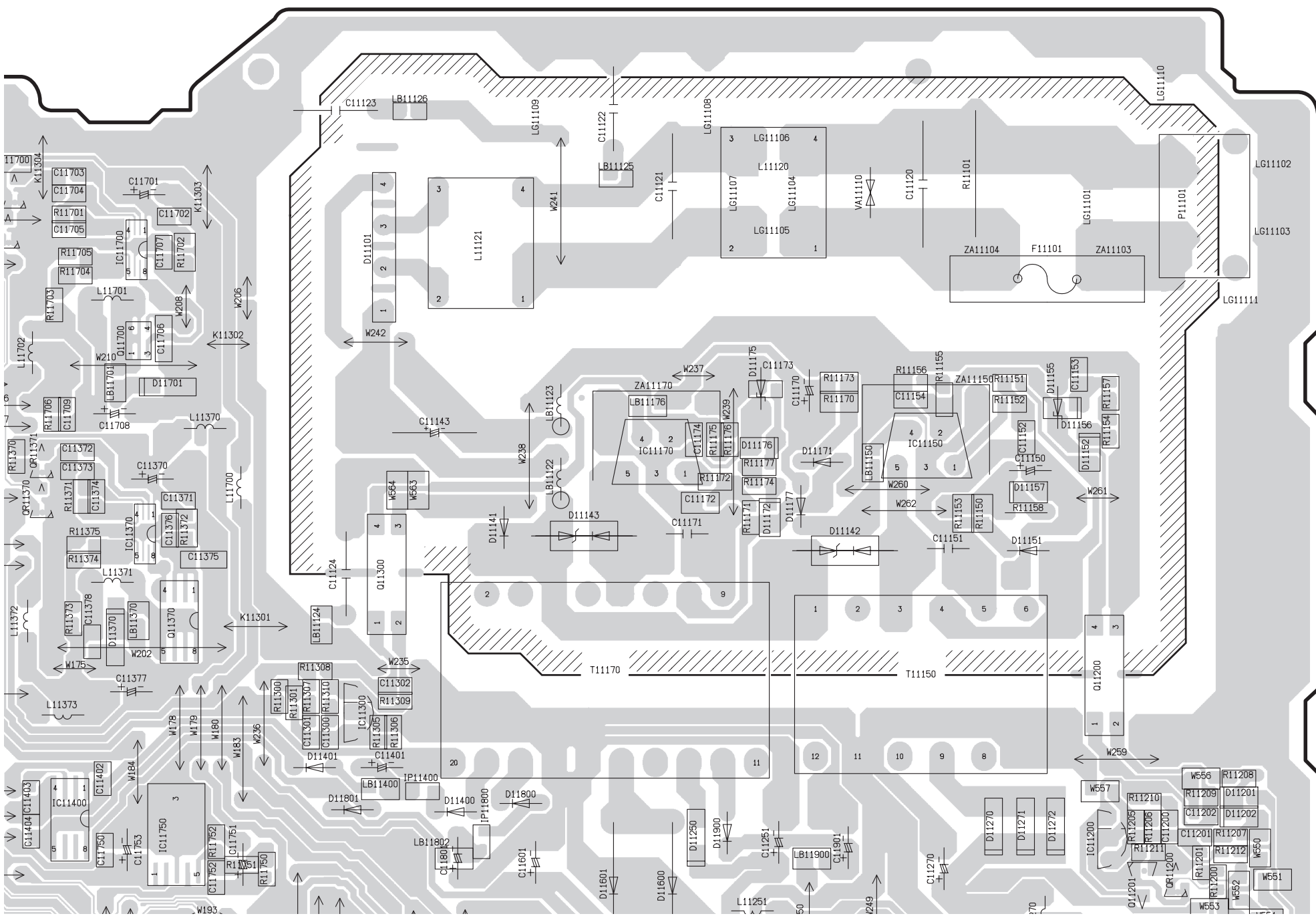

DMR-EX98VEB/EC/EG  
 Dig. Interface P.C.B.  
 (RFB71134A: EX98VEB,  
 RFB71134AT: EX98VEC/EG)  
 (4/4 Section)

### 13.1.5. Dig. Interface P.C.B. Address Information

Dig. Interface P.C.B.																	
<b>Integrated Circuit</b>	CL9721	A8	D11172	D7	LB9704	E4	C11404	C5	C9731	B3	R11206	C8	R9705	B5	R9777	C2	
IC11150	D7	CL9722	A5	D11175	D6	LB9705	C2	C11601	C6	C9733	C2	R11207	C8	R9706	D1	R9778	B3
IC11170	D6	CL9723	A5	D11176	D7	LB9706	B2	C11602	C6	C9734	D1	R11208	C8	R9707	C2	R9779	E1
IC11200	C8	CL9724	A7	D11177	D7	LB9707	E3	C11701	E5	C9735	B2	R11209	C8	R9708	B6	R9780	D1
IC11300	C6	CL9725	A7	D11201	C8	LB9708	D3	C11702	E5	C9736	B3	R11210	C8	R9709	B6	R9781	D2
IC11370	D5	CL9726	A7	D11202	C8	LB9709	D3	C11703	E5	C9737	B2	R11211	C8	R9710	B6	R9782	C3
IC11400	C5	CL9727	A6	D11250	C7	LB9711	D2	C11704	E5	C9738	C3	R11212	C8	R9711	B6	R9783	B2
IC11700	E5	CL9728	B6	D11270	C7	LB9712	D3	C11705	E5	C9739	C3	R11270	B8	R9712	B6	R9784	C2
IC11750	C5	CL9729	B1	D11271	C7	LB9713	E3	C11706	D5	C9740	B6	R11271	C8	R9713	C3	R9785	D1
IC9102	B6	CL9730	B2	D11272	C8	LB9714	E3	C11707	E5	C9741	B6	R11272	B8	R9714	C3	R9786	C2
IC9106	B5	CL9731	A1	D11370	D5	LB9715	B2	C11708	D5	C9742	C3	R11273	B8	R9715	D3	R9787	B3
IC9301	E2	CL9732	C1	D11400	C6	LB9716	D3	C11709	D5	C9744	B2	R11274	B8	R9716	D3	R9788	C3
IC9302	B7	CL9733	D4	D11401	C5	LB9717	E3	C11750	C5	C9745	C2	R11300	C5	R9717	C2	R9789	C3
IC9305	B7	CL9734	B3	D11600	C6	LB9718	E3	C11751	C5	C9746	B2	R11301	C5	R9718	B6	R9790	C3
IC9700	A8	CL9735	E3	D11601	C6	LB9719	D3	C11752	C5	C9747	C2	R11305	C6	R9719	B3	R9791	B2
IC9701	C2	CL9736	E3	D11701	D5	LB9720	D3	C11753	C5	C9748	B2	R11306	C6	R9720	C2	R9792	A8
IC9702	E1	CL9737	D3	D11800	C6	LB9721	A7	C11801	C6	C9749	D2	R11307	C6	R9721	C2	R9793	B8
IC9703	B2	CL9738	D3	D11801	C6	LB9723	B7	C11901	C7	C9750	B2	R11308	D6	R9722	B2	R9794	C3
IC9705	D2	CL9739	D3	D11900	C7	LB9724	A7	C9111	B6	C9752	C2	R11309	C6	R9723	B3	R9795	D3
IC9706	B2	CL9740	E2	D9104	E2	LB9725	B8	C9112	A3	C9753	C2	R11310	C6	R9724	C3	R9796	C3
IC9707	A8	CL9741	D3	D9105	E2	LB9726	B8	C9116	B6	C9754	C3	R11370	D5	R9725	C2	R9797	C3
IC9708	D2	CL9742	D3	D9106	E2	<b>Fuse</b>		C9117	B5	C9755	D3	R11371	D5	R9726	D2	R9798	C2
		CL9743	D3	D9107	E2	F11101	E7	C9156	E2	C9756	E1	R11372	D5	R9727	B6	R9799	B8
<b>Transistor</b>	CL9744	E4	D9202	D2	<b>Capacitor</b>			C9157	E1	C9757	D2	R11373	D5	R9728	B6	R9800	C2
Q11200	D8	CL9745	D3	D9302	A8	C11120	E7	C9158	E2	C9759	D2	R11374	D5	R9729	C3	R9801	C2
Q11201	C8	CL9746	E2	D9702	C3	C11121	E6	C9201	D1	C9760	D3	R11375	D5	R9730	D1	R9802	D2
Q11270	C8	CL9747	D2	D9705	B2	C11122	E6	C9202	D1	C9761	D3	R11700	E5	R9731	E1	R9810	D2
Q11271	B8	CL9748	D3	<b>Crystal Osillator</b>		C11123	E5	C9301	E2	C9764	B2	R11701	E5	R9732	C3	R9811	D2
Q11300	D6	CL9749	E2	X9701	C3	C11124	D5	C9302	E3	C9766	E4	R11702	E5	R9733	C3	R9814	B7
Q11370	D5	CL9750	E2	X9702	C2	C11143	D6	C9303	B7	C9767	E4	R11703	E5	R9734	C3	R9815	C2
Q11700	E5	CL9751	E2	<b>IC Protector</b>		C11150	D7	C9305	B7	C9768	E4	R11704	E5	R9735	D2	R9816	D2
Q9101	E2	CL9752	E2	IP11400	C6	C11151	D7	C9306	B7	C9769	E3	R11705	E5	R9736	E1	R9817	C2
Q9106	E2	CL9753	E2	IP11800	C6	C11152	D8	C9309	B7	C9771	A8	R11706	D5	R9737	C3	R9818	B1
Q9202	D1	CL9754	E2	IP9102	E2	C11153	D8	C9310	B7	C9772	A8	R11750	C5	R9738	C3	R9819	B1
Q9203	D1	CL9755	A6	<b>Coil</b>		C11154	D7	C9311	B8	C9777	C3	R11751	C5	R9739	D1	R9824	C3
Q9204	D1	CL9756	B7	L11120	E7	C11170	D7	C9312	A8	C9778	C2	R11752	C5	R9740	B6	R9825	C2
Q9301	A8	CL9757	B8	L11121	E6	C11171	D6	C9331	B6	C9779	C2	R9102	E2	R9741	B2	R9829	D2
Q9302	A8	CL9758	B7	L11251	C7	C11172	D7	C9332	B7	C9780	C2	R9132	B2	R9742	D2	R9830	C3
Q9701	D1	CL9759	B6	L11270	C8	C11173	D7	C9333	B7	C9781	C2	R9143	E1	R9743	D2	R9831	C3
Q9702	D1	CL9759	B6	L11270	C8	C11173	D7	C9333	B7	C9781	C2	R9143	E1	R9743	D2	R9831	C3
Q9703	B6	CL9760	B1	L11271	B8	C11174	D7	C9336	B7	C9785	E3	R9144	E2	R9744	C3	R9834	D3
Q9704	B6	CL9761	B1	L11370	D5	C11200	C8	C9337	B7	C9786	C3	R9145	E2	R9745	C3	R9835	D3
Q9705	D1	TL9701	D1	L11371	D5	C11201	C8	C9701	D1	C9787	C3	R9146	E2	R9746	D2	R9836	E3
Q9706	D1	TL9702	C2	L11372	D5	C11202	C8	C9702	D2	C9790	E2	R9201	D1	R9747	C2	R9837	E3
Q9707	C3	TL9703	C3	L11373	C5	C11251	C7	C9703	B5	C9791	D2	R9205	C1	R9748	C2	R9838	E3
Q9708	B1	TL9704	C2	L11601	C6	C11252	C6	C9704	E1	C9792	D2	R9207	C2	R9749	C2	R9839	E2
		TL9705	D2	L11700	D5	C11270	C7	C9705	B5	C9793	E3	R9208	C1	R9750	C2	R9840	E2
<b>Transistor-resistor</b>	CL9744	E4	D9202	D2	<b>Capacitor</b>			C9157	E1	C9757	D2	R11373	D5	R9728	B6	R9800	C2
QR11200	C8	<b>Connector</b>	L11701	E5	C11272	C8	C9706	B2	C9794	A8	R9209	D1	R9751	A7	R9841	E2	
QR11270	C8	P11101	L11702	E5	C11273	C8	C9707	B2	C9795	E3	R9210	D1	R9752	C3	R9842	D3	
QR11271	B8	P9101	B3	L9105	E2	C11274	C8	C9708	C2	<b>Resistor</b>	R9211	D1	R9753	C2	R9843	D3	
QR11370	D5	P9102	A6	L9106	E2	C11275	B8	C9709	C3	R11101	E7	R9212	D1	R9754	C1	R9845	D2
QR11371	D5	P9103	A7	L9700	A8	C11276	B8	C9710	D2	R11150	D7	R9213	D1	R9755	D2	R9846	D2
QR11700	E5	P9104	A6	L9701	E4	C11277	B8	C9711	D2	R11151	D7	R9214	D1	R9756	C1	R9847	D2
QR11701	E5	P9700	B7	L9702	D3	C11278	B8	C9712	C3	R11152	D7	R9303	A8	R9757	C1	<b>Transformer</b>	
QR9301	B6	P9701	B6	L9703	D2	C11279	A8	C9713	D1	R11153	D7	R9304	A8	R9758	C2	T11150	D7
QR9701	E1	P9703	E3	LB11122	D6	C11300	C6	C9714	A8	R11154	D8	R9310	A8	R9759	C3	T11170	D6
QR9703	B2	P9704	B3	LB11123	D6	C11301	C6	C9715	E1	R11155	D7	R9311	A8	R9760	C3	<b>Varistor</b>	
QR9704	B3	P9705	B6	LB11124	D6	C11302	D6	C9716	B2	R11156	D7	R9312	A8	R9761	A7	VA11110	E7
QR9705	C3	P9707	B7	LB11125	E6	C11370	D5	C9717	C2	R11157	D8	R9313	A8	R9764	C2		
QR9706	C3	PS9701	B1	LB11126	E6	C11371	D5	C9718	D3	R11158	D7	R9314	A8	R9765	B2		
QR9707	B1	<b>Diode</b>	LB11150	D7	C11372	D5	C9719	C3	R11170	D7	R9315	A8	R9766	B2			
<b>Test Point</b>	D11101	E5	LB11176	D6	C11373	D5	C9720	D2	R11171	D7	R9331	B7	R9767	C3			
CL9711	B3	D11141	D6	LB11370	D5	C11374	D5	C9721	B5	R11172	D7	R9333	B7	R9768	C3		
CL9712	A3	D11142	D7	LB11400	C6	C11375	D5	C9722	A8	R11173	D7	R9335	B7	R9769	B2		
CL9713	A3	D11143	D6	LB11701	D5	C11376	D5	C9723	A8	R11174	D7	R9336	B7	R9770	C3		
CL9714	A4	D11151	D7	LB11802	C6	C11377	D5	C9724	D3	R11175	D7	R9337	B7	R9771	C3		
CL9715	A7	D11152	D8	LB11900	C7	C11378	D5	C9725	C2	R11176	D7	R9338	B7	R9772	C2		
CL9716	A6	D11155	D7	LB9700	E3	C11379	D4	C9726	C2	R11177	D7	R9701	C1	R9773	C2		
CL9717	A7	D11156	D8	LB9701	D3	C11401	C6	C9727	B8	R11200	C8	R9702	C3	R9774	B2		
CL9718	A7	D11157	D8	LB9702	E2	C11402	C5	C9728	C3	R11201	C8	R9703	C2	R9775	B3		
CL9720	A7	D11171	D7	LB9703	E3	C11403	C5	C9730	C3	R11205	C8	R9704	D1	R9776	C2		

## 13.2. Main P.C.B.

### 13.2.1. Main P.C.B. (1/4 Section)

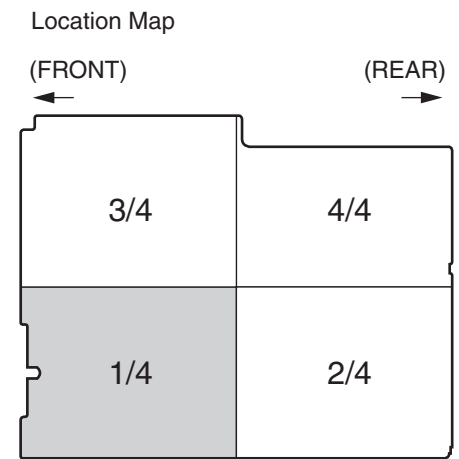
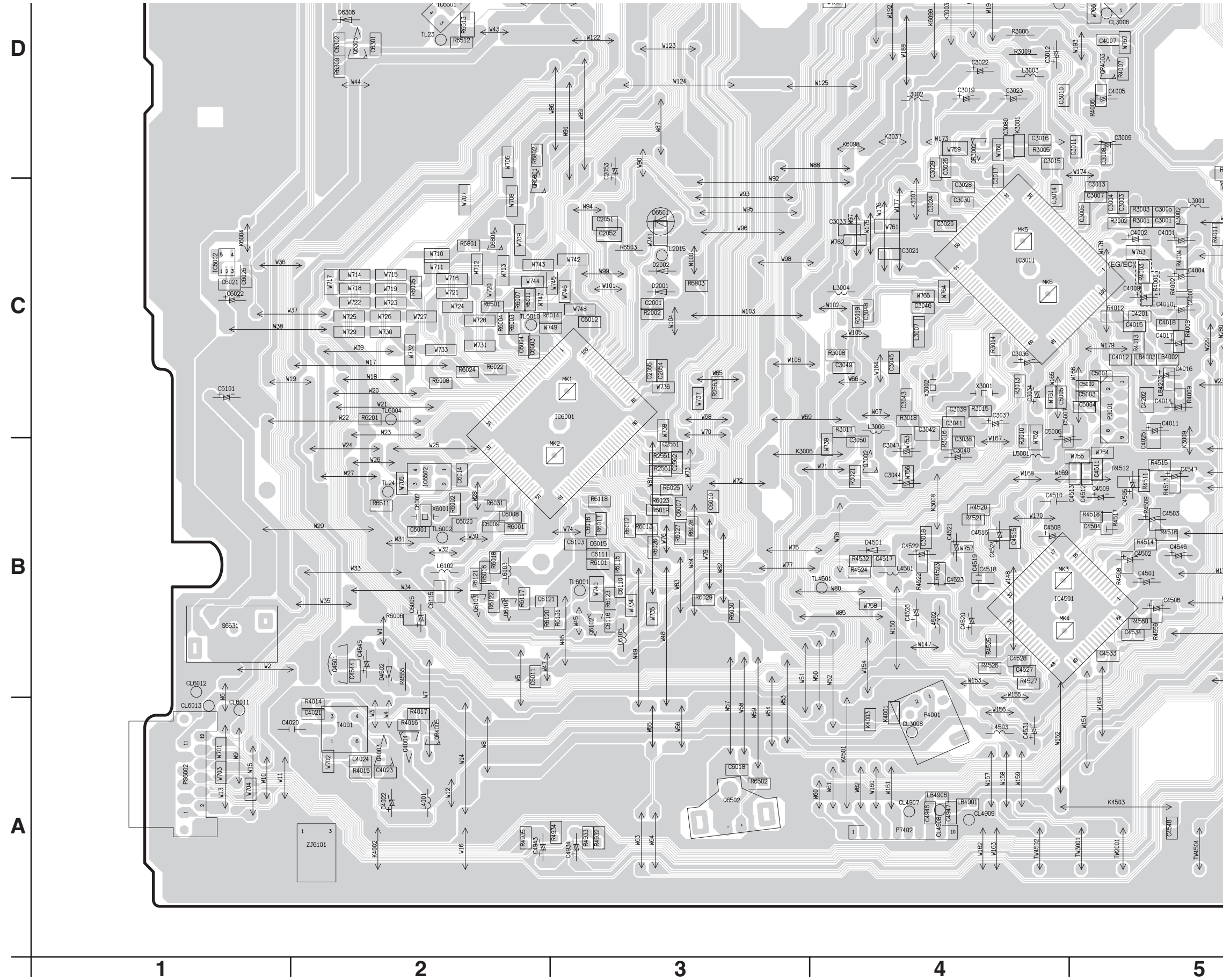

DMR-EX98VEB/EC/EG  
Main P.C.B.  
(VEP79195A: EX98VEB,  
VEP79195B: EX98VEG,  
VEP79195C: EX98VEC)  
(1/4 Section)

13.2.2. Main P.C.B. (2/4 Section)

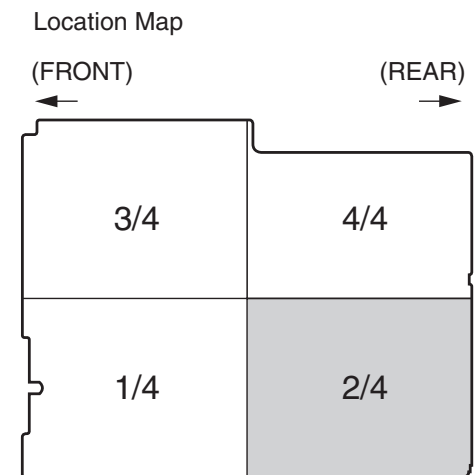
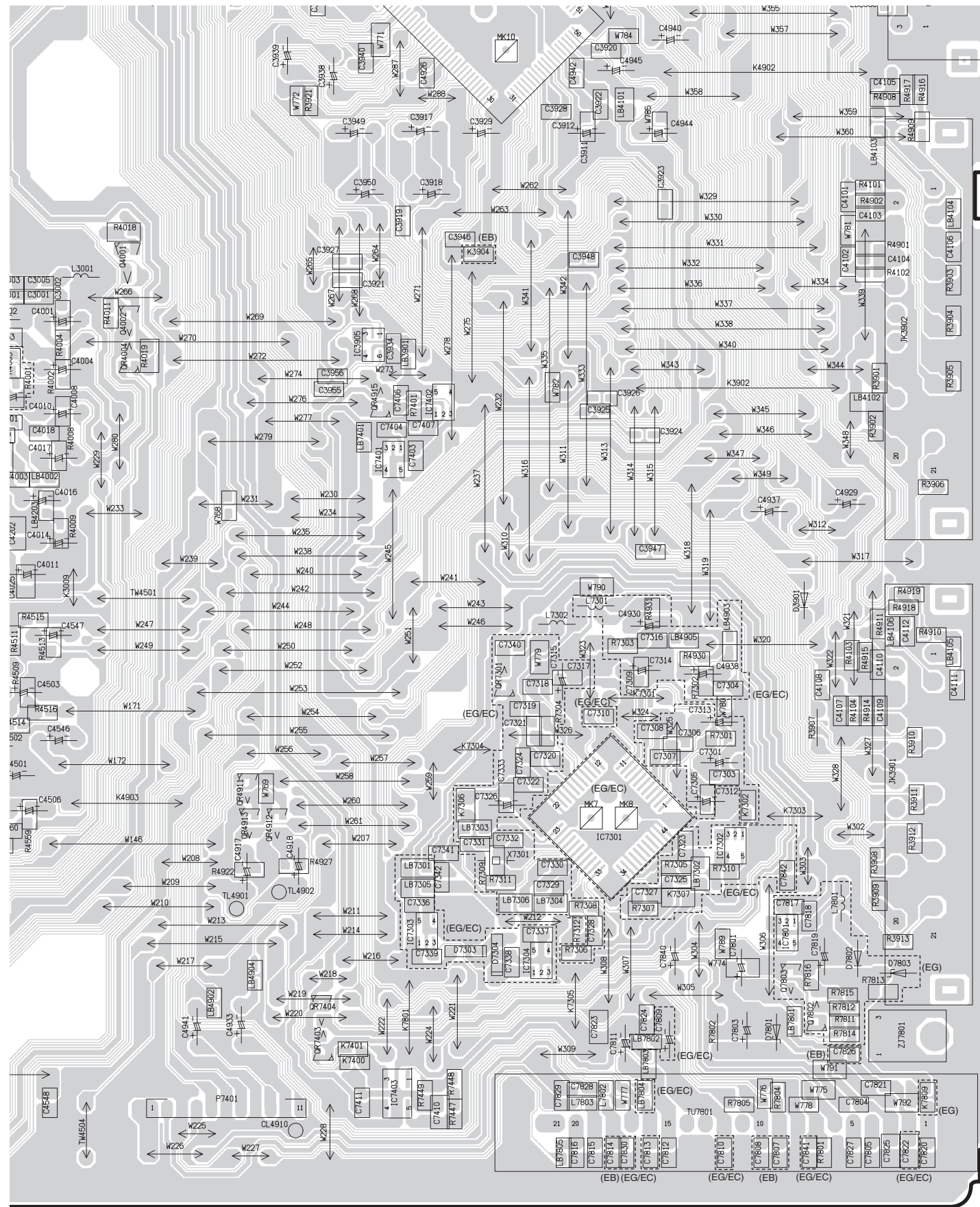

DMR-EX98VEB/EC/EG  
Main P.C.B.  
(VEP79195A: EX98VEB,  
VEP79195B: EX98VEG,  
VEP79195C: EX98VEC)  
(2/4 Section)

5

6

7

8

9



13.2.4. Main P.C.B. (4/4 Section)

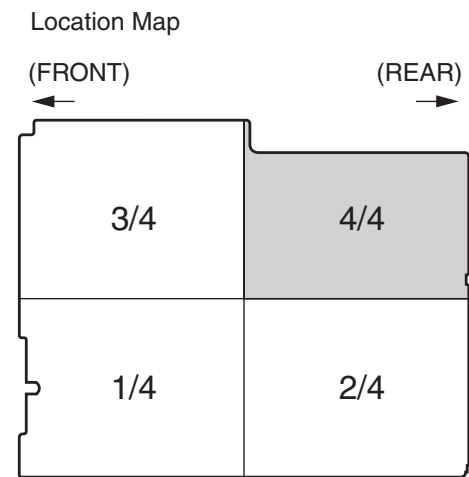
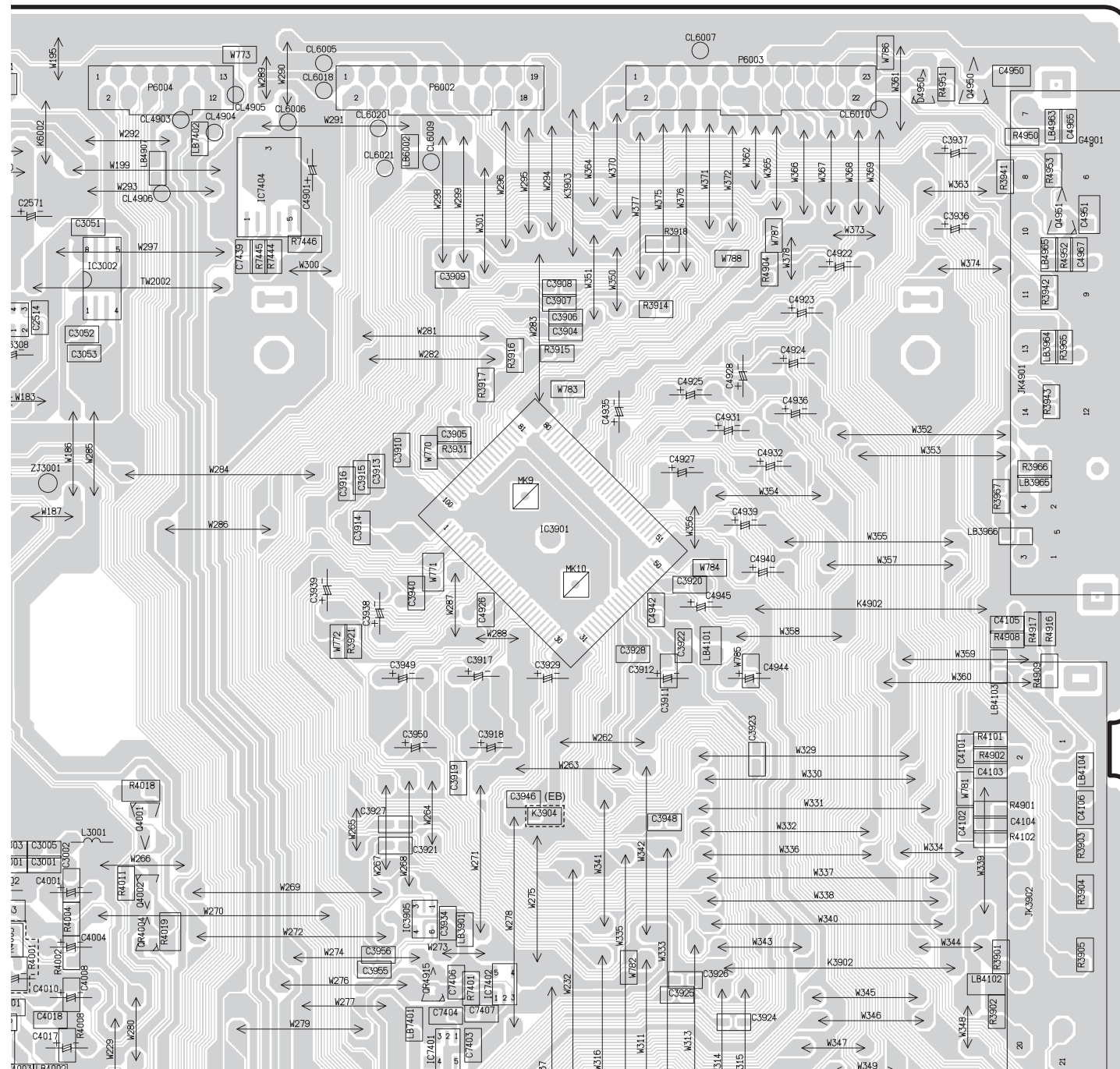

DMR-EX98VEB/EC/EG  
Main P.C.B.  
(VEP79195A: EX98VEB,  
VEP79195B: EX98VEG,  
VEP79195C: EX98VEC)  
(4/4 Section)

13.2.5. Main P.C.B. Address Information

Integrated Circuit		Main P.C.B.																			
IC2501	E4	CL6010	E7	L6105	B3	C3003	C5	C3937	E7	C4545	B2	C7301	B7	C7842	B7	R4016	A2	R6024	C2		
IC3001	C4	CL6011	A1	L6110	E5	C3004	C5	C3938	D6	C4546	B5	C7303	B7	Resistor	E4	R4017	A2	R6025	B3		
IC3002	E5	CL6012	B1	L7301	B7	C3005	C5	C3939	D6	C4547	B5	C7304	B7	R2001	C3	R4018	D5	R6026	B3		
IC3901	D6	CL6013	A1	L7302	B6	C3006	C5	C3940	D6	C4548	A5	C7305	B7	R2002	D5	R4019	C5	R6027	B3		
IC3905	C6	CL6014	E4	L7801	B7	C3007	C5	C3946	C6	C4901	E6	C7306	B7	R2099	D5	R4101	D7	R6028	B3		
IC4501	B4	CL6015	E4	L7802	A7	C3008	D5	C3947	C7	C4917	B6	C7307	B7	R2501	E4	R4102	C7	R6029	B3		
IC6001	C3	CL6016	E4	L7803	A6	C3009	D5	C3948	C6	C4918	B6	C7308	B7	R2502	E4	R4103	B7	R6030	B3		
IC6002	C1	CL6017	E4	LB3901	C6	C3010	D4	C3949	D6	C4922	E7	C7309	B7	R2503	E4	R4104	B7	R6031	B2		
IC6302	E5	CL6018	E6	LB3964	E7	C3011	D5	C3950	D6	C4923	E7	C7310	B7	R2514	E4	R4508	B5	R6101	B3		
IC6501	D2	CL6019	E5	LB3965	D7	C3012	D5	C3955	C6	C4924	E7	C7312	B7	R2515	E4	R4509	B5	R6115	B3		
IC6502	B2	CL6020	E6	LB3966	D7	C3013	C5	C3956	C6	C4925	E7	C7313	B7	R2516	E5	R4511	B5	R6117	B2		
IC7301	B6	CL6021	E6	LB4002	C5	C3014	C4	C4001	C5	C4926	D6	C7314	B7	R2520	E4	R4512	B5	R6118	B3		
IC7302	B7	TL2015	C3	LB4003	C5	C3015	D4	C4002	C5	C4927	D7	C7315	B6	R2521	E4	R4513	B5	R6120	B2		
IC7303	B6	TL23	D2	LB4101	D7	C3016	D4	C4004	C5	C4928	E7	C7316	B7	R2551	B3	R4514	B5	R6121	B2		
IC7303	B6	TL24	B2	LB4102	C7	C3017	C4	C4005	D5	C4929	C7	C7317	B6	R2552	E3	R4515	B5	R6122	B2		
IC7304	A6	TL2502	E4	LB4103	D7	C3018	B4	C4007	D5	C4930	B7	C7318	B6	R2561	B3	R4516	B5	R6123	B3		
IC7401	C6	TL3001	D4	LB4104	D7	C3019	D4	C4008	C5	C4931	D7	C7319	B6	R2562	E4	R4517	B5	R6131	B3		
IC7402	C6	TL4501	B4	LB4105	B7	C3020	C4	C4009	C5	C4932	D7	C7320	B6	R2563	C3	R4518	B5	R6201	C2		
IC7403	A6	TL4901	B5	LB4106	B7	C3021	C4	C4010	C5	C4933	A5	C7321	B6	R2564	E4	R4519	D4	R6309	D2		
IC7404	E5	TL4902	B6	LB4203	C5	C3022	D4	C4011	C5	C4934	A3	C7322	B6	R2565	E4	R4520	B4	R6501	C2		
IC7801	A7	TL6001	B3	LB4901	A4	C3023	D4	C4012	C5	C4935	D6	C7323	B7	R3001	C5	R4521	B4	R6502	A3		
<b>Transistor</b>		TL6002	B2	LB4902	A5	C3024	D4	C4014	C5	C4936	D7	C7324	B6	R3002	C5	R4522	B4	R6503	C3		
Q3002	B4	TL6004	C2	LB4903	B7	C3026	D4	C4015	C5	C4937	C7	C7325	B7	R3003	C5	R4523	B4	R6511	B2		
Q4001	C5	TL6010	C2	LB4904	A6	C3028	C4	C4016	C5	C4938	B7	C7326	B6	R3005	D4	R4524	B4	R6512	D2		
Q4002	C5	<b>Connector</b>		LB4905	B7	C3029	D4	C4017	C5	C4939	D7	C7327	B7	R3006	D4	R4525	B4	R6513	D2		
Q4003	A2	JK3901	A7	LB4906	A4	C3030	C4	C4018	C5	C4940	D7	C7328	B7	R3008	C4	R4526	B4	R6801	C2		
Q4004	A2	JK3902	C7	LB4907	E5	C3033	C4	C4020	A2	C4941	A5	C7329	B6	R3009	D4	R4527	B4	R6802	D2		
Q4501	B2	JK4901	D7	LB4963	E7	C3034	C4	C4021	A2	C4942	D6	C7330	B6	R3010	C4	R4528	D4	R6803	C3		
Q4502	D4	P2501	E5	LB4965	E7	C3036	C4	C4022	A2	C4943	A3	C7331	B6	R3013	C4	R4532	B4	R7301	B7		
Q4950	E7	P2571	E4	LB6002	E6	C3037	C4	C4023	A2	C4944	D6	C7332	B6	R3014	C4	R4555	B2	R7302	B7		
Q4951	E7	P3001	C5	LB7301	B6	C3038	B4	C4024	A2	C4945	D6	C7333	B6	R3015	C4	R4559	B5	R7303	B7		
Q6102	B3	P4001	A4	LB7302	B7	C3039	B4	C4025	C5	C4946	A4	C7336	B6	R3016	B4	R4560	B5	R7304	B6		
Q6103	B2	P4002	D5	LB7303	B6	C3040	B4	C4101	D7	C4947	A4	C7337	A6	R3017	C4	R4901	C7	R7305	B7		
Q6104	B2	P6001	F3	LB7304	B6	C3041	C4	C4102	C7	C4950	E7	C7338	A6	R3018	C4	R4902	D7	R7306	A6		
Q6305	D2	P6002	E6	LB7305	B6	C3042	C4	C4103	D7	C4951	A6	C7339	A6	R3019	C4	R4904	E7	R7307	B7		
Q6501	F3	P6003	E7	LB7306	B6	C3043	C4	C4104	C7	C4965	B6	C7340	B6	R3021	B4	R4908	D7	R7308	B6		
Q6502	A3	P6004	E5	LB7401	C6	C3044	B4	C4105	D7	C4967	E7	C7341	B6	R3901	C7	R4909	D7	R7309	B6		
Q6801	C2	P6531	E5	LB7402	E5	C3045	C4	C4106	C7	C5001	C5	C7342	B6	R3902	C7	R4910	B7	R7310	B7		
Q7802	A7	P7401	A5	LB7801	A7	C3046	C4	C4107	B7	C5002	C5	C7403	C6	R3903	C7	R4911	B7	R7311	B6		
Q7803	A7	P7402	A4	LB7802	A7	C3047	B4	C4108	B7	C5003	C5	C7404	C6	R3904	C7	R4914	C7	R7312	B6		
<b>Transistor-resistor</b>		PS6002	A1	LB7803	A7	C3048	C4	C4109	B7	C5004	C5	C7406	C6	R3905	C7	R4915	B7	R7401	C6		
QR3002	D4	<b>Diode</b>		LB7804	A7	C3049	C4	C4110	C4	C5005	C4	C7407	C6	R3906	C7	R4916	D7	R7444	E5		
QR4003	D5	D2001	C3	LB7805	A6	C3050	B4	C4111	B7	C5006	B5	C7410	A6	R3907	B7	R4917	D7	R7445	E5		
QR4004	C5	D2002	C3	<b>Capacitor</b>		C3051	E5	C4112	B7	C5007	C5	C7411	A6	R3908	B7	R4918	B7	R7446	E6		
QR4005	A2	D2502	E4	C2001	C3	C3052	E5	C4201	C5	C6001	B2	C7439	E5	R3909	B7	R4919	B7	R7447	A6		
QR4501	D4	D3901	C7	C2003	E4	C3053	E5	C4202	C5	C6002	B2	C7801	A7	R3910	B7	R4922	B5	R7448	A6		
QR4911	B5	D4501	B4	C2051	C3	C3080	D4	C4501	B5	C6003	C2	C7803	A7	R3911	B7	R4927	B6	R7449	A6		
QR4912	B6	D4502	B2	C2052	C3	C3904	E6	C4502	B5	C6004	C2	C7804	A7	R3912	B7	R4930	B7	R7801	A7		
QR4913	B5	D4950	E7	C2053	C3	C3905	D6	C4503	B5	C6005	B2	C7805	A7	R3913	A7	R4931	B7	R7802	A7		
QR4915	C6	D6306	D2	C2054	C3	C3906	E6	C4504	B5	C6007	B3	C7807	A7	R3914	E6	R4932	A3	R7804	A7		
QR6801	C2	D6501	C3	C2055	C3	C3907	E6	C4505	B5	C6008	B2	C7808	A7	R3915	E6	R4933	A3	R7805	A7		
QR7301	B6	D7303	A6	C2099	D5	C3908	E6	C4506	B5	C6009	B2	C7809	A7	R3916	E6	R4934	A3	R7811	A7		
QR7403	A6	D7304	A6	C2501	E4	C3909	E6	C4508	B4	C6010	B3	C7810	A7	R3917	E6	R4935	A2	R7812	A7		
QR7404	A6	D7801	A7	C2502	E4	C3910	D6	C4509	B5	C6011	B2	C7811	A7	R3918	E6	R4950	E7	R7813	A7		
<b>Test Point</b>		D7802	A7	C2504	E4	C3911	D6	C4510	B4	C6012	C3	C7812	A7	R3921	D6	R4951	E7	R7814	A7		
CL3005	D4	D7803	A7	C2505	E4	C3912	D7	C4511	B5	C6014	B2	C7813	A7	R3931	D6	R4952	E7	R7815	A7		
CL3006	D5	<b>Crystal Oscillator</b>		C2506	E4	C3913	D6	C4512	B5	C6015	B3	C7814	A7	R3941	E7	R4953	E7	R7816	A7		
CL3007	D5	X3001	C4	C2507	E4	C3914	D6	C4513	B5	C6016	B3	C7815	A7	R3942	E7	R6001	B2	<b>Switch</b>			
CL3008	A4	X3002	C4	C2508	E4	C3915	D6	C4515	B4	C6017	F3	C7816	A6	R3943	D7	R6002	B2	S6531	B1		
CL4903	E5	X6001	B2	C2509	E4	C3916	D6	C4516	B4	C6018	A3	C7817	B7	R3965	E7	R6003	C2	S6532	E2		
CL4904	E5	X7301	B6	C2510	E4	C3917	D6	C4517	B4	C6020	B2	C7818	B7	R3966	D7	R6004	C2	<b>Transformer</b>			
CL4905	E5	<b>Coil</b>		C2511	E4	C3918	D6	C4518	B4	C6021	C1	C7819	A7	R3967	D7	R6005	C2	T4001	A2		
CL4906	E5	L3001	C5	C2512	E5	C3919	D6	C4519	B4	C6022	C1	C7820	A7	R3967	C5	R6006	B2	<b>Tuner</b>			
CL4907	A4	L3002	D4	C2513	E4	C3920	D7	C4520	B4	C6026	C1	C7821	A7	R4002	C5	R6007	C2	TU7801	A7		
CL4908	A4	L3003	D4	C2514	E5	C3921	C6	C4521	B4	C6101	C1	C7822	A7	R4003	C5	R6008	C2				
CL4909	A4	L3004	C4	C2515	E4	C3922	D7	C4522	B4	C6103	B3	C7823	A7	R4004	C5	R6011	C2				
CL4910	A6	L3006	C4	C2518	E4	C3923	D7	C4523	B4	C6110	B3	C7824	A7	R4006	D5	R6012	B3				
CL6001	F3	L3007	C4	C2519	E4	C3924	C7	C4524	B4	C6111	B3	C7825	A7	R4007	D5	R6013	B3				
CL6002	F4	L4001	A2	C2551	B3	C3925	C7	C4526	B4</												

### 13.3. HDMI P.C.B.

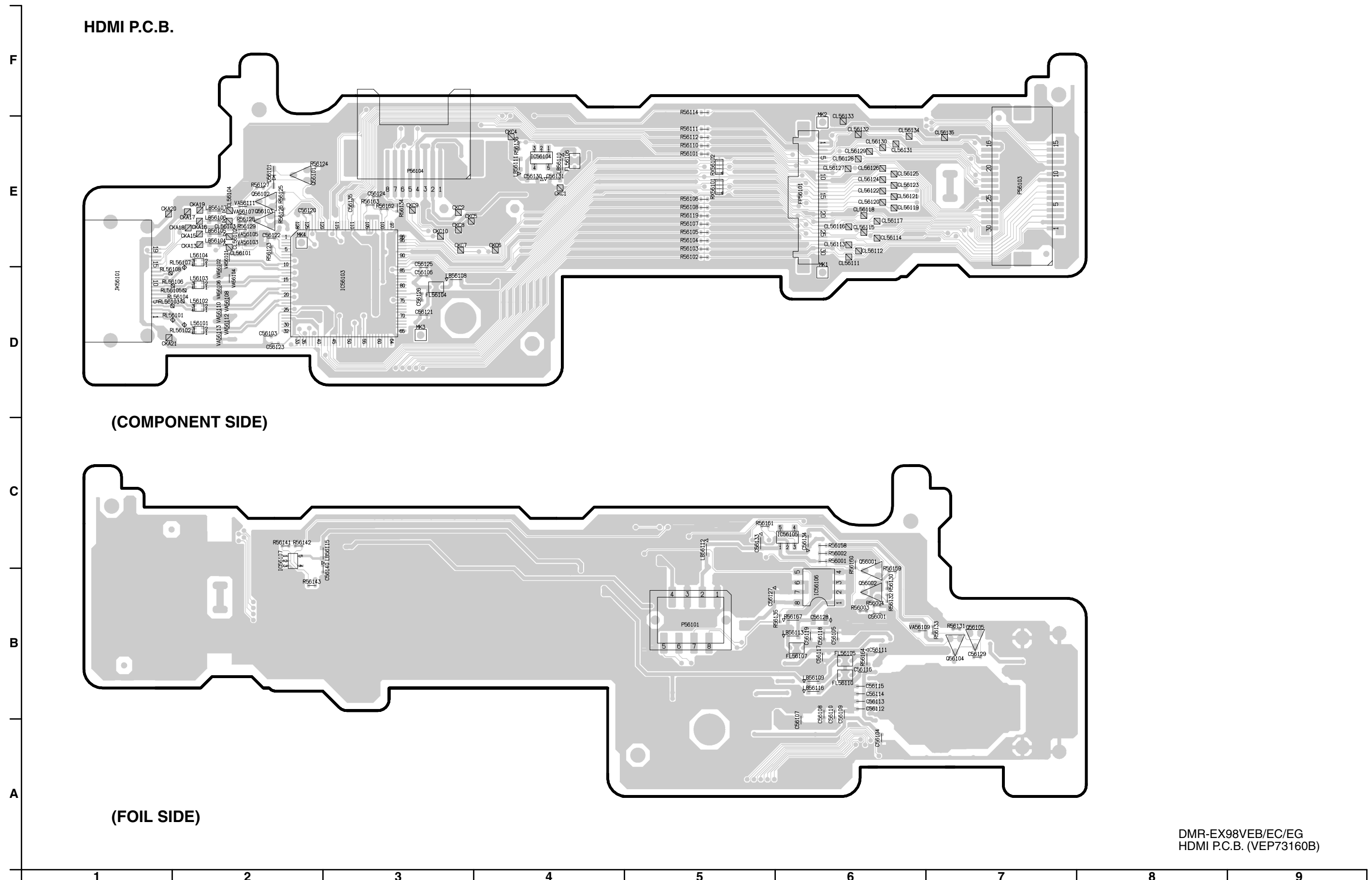

DMR-EX98VEB/EC/EG  
HDMI P.C.B. (VEP73160B)

### 13.4. FL Drive P.C.B.

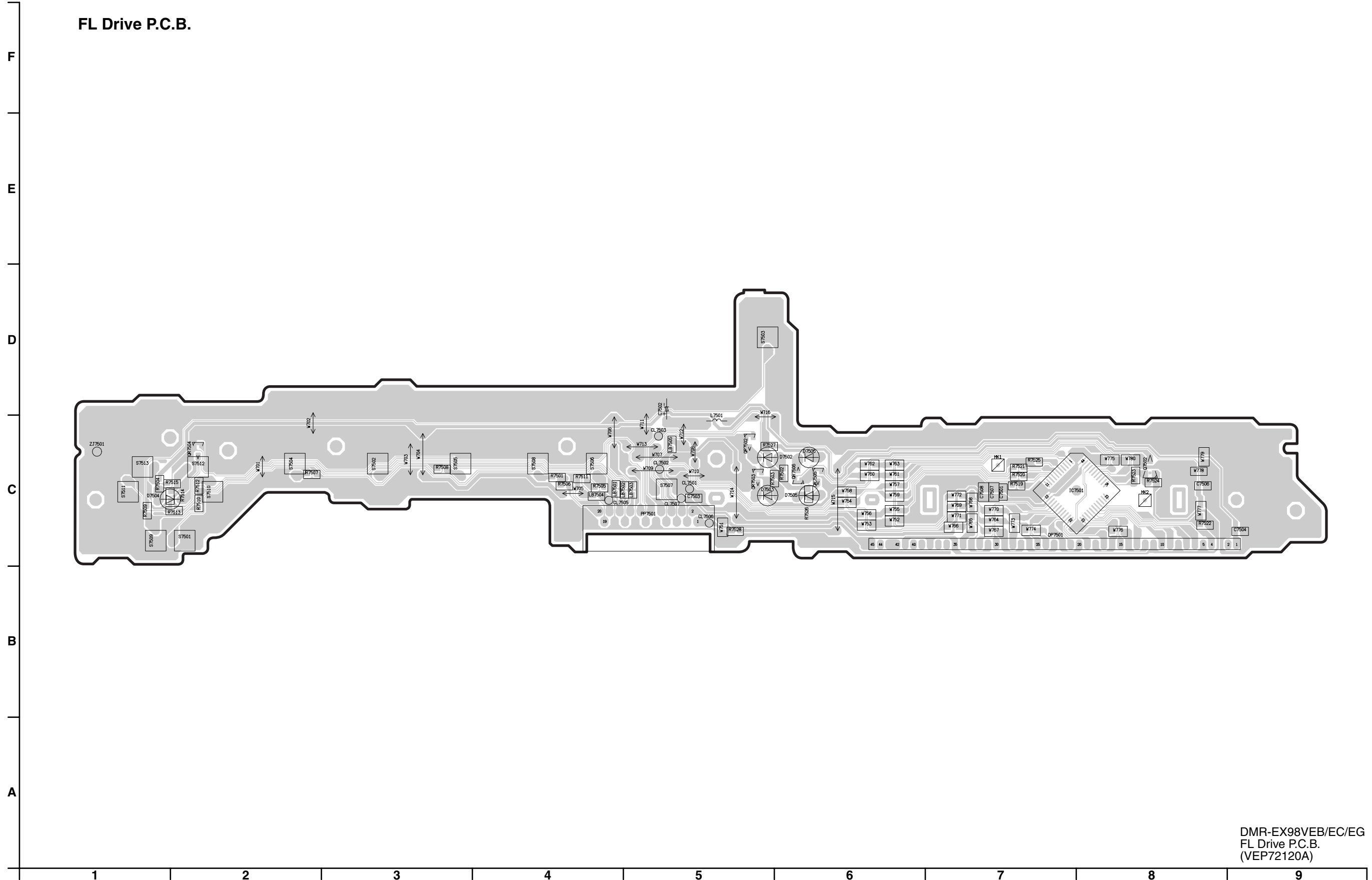

DMR-EX98VEB/EC/EG  
FL Drive P.C.B.  
(VEP72120A)

13.5. DV/SD/USB P.C.B.

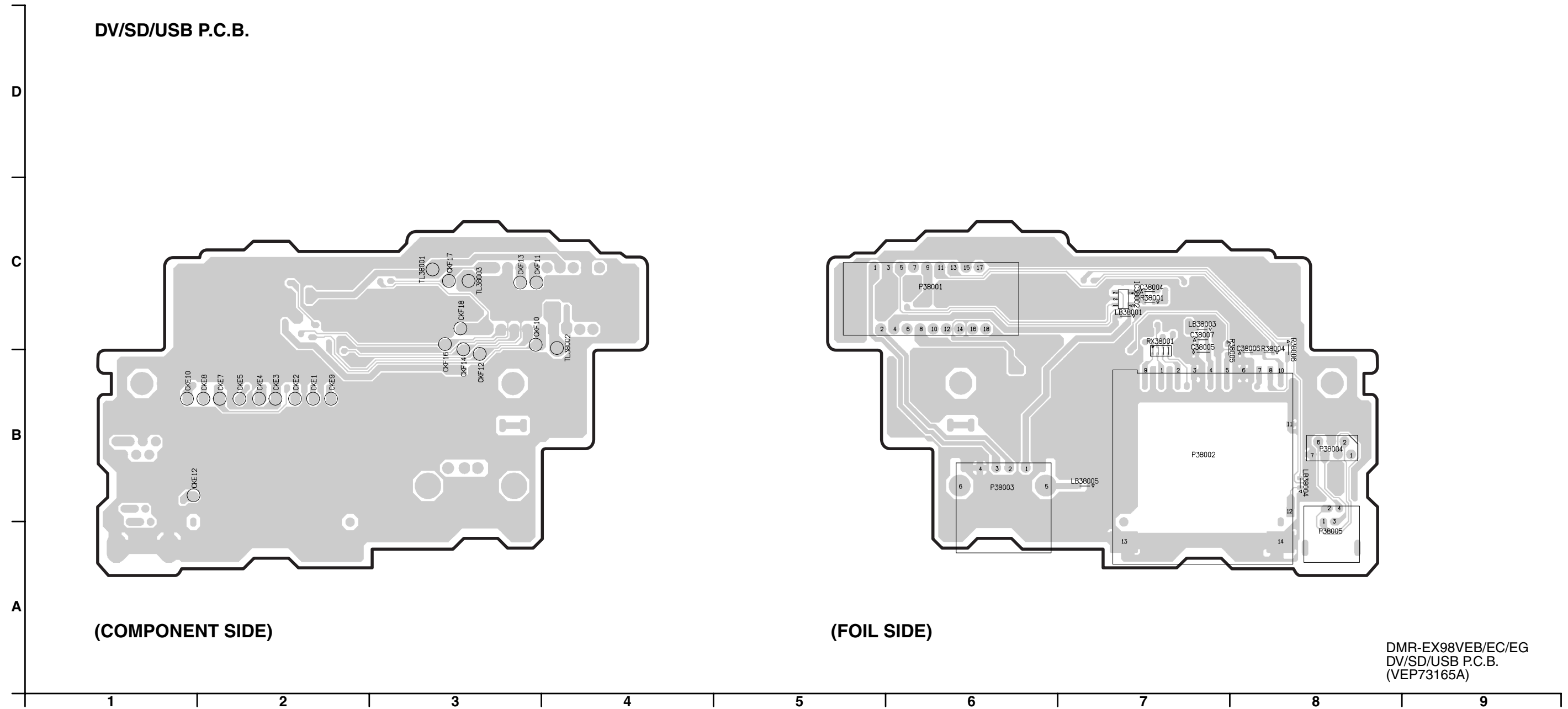

### 13.6. ATAPI P.C.B.

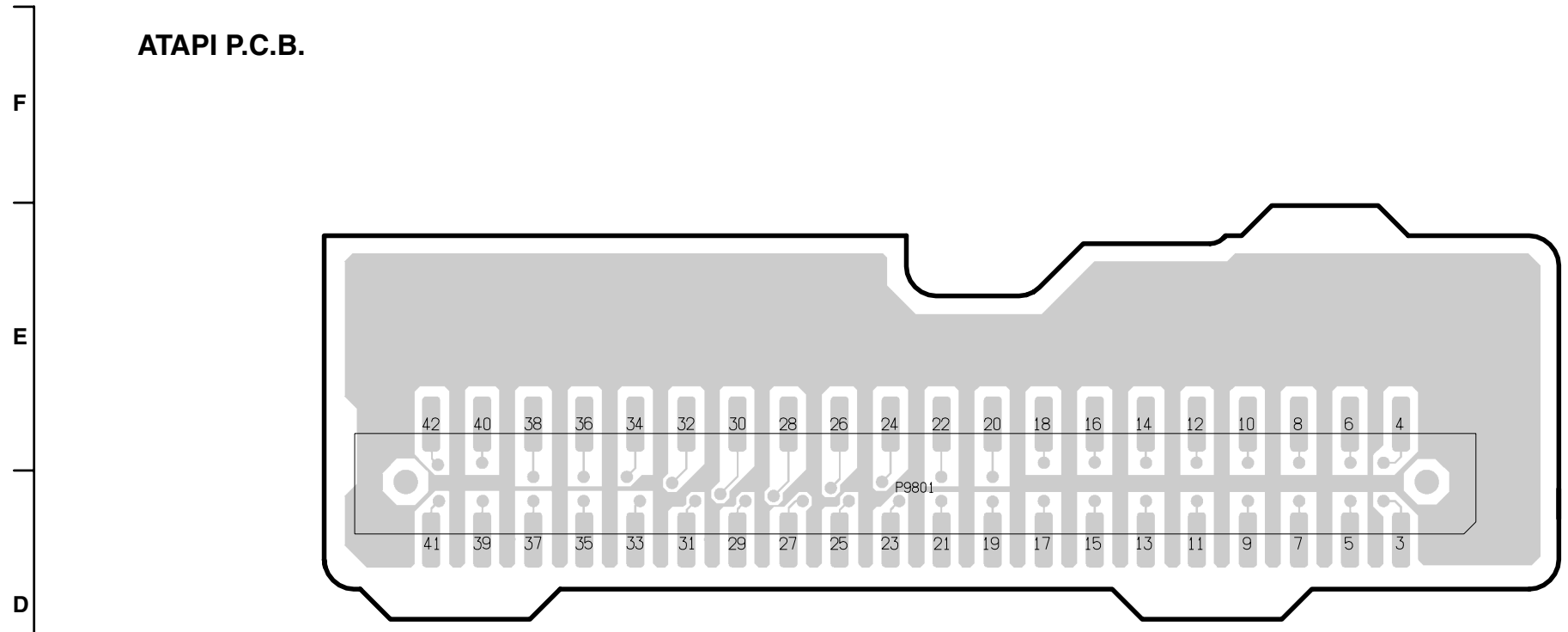

(COMPONENT SIDE)

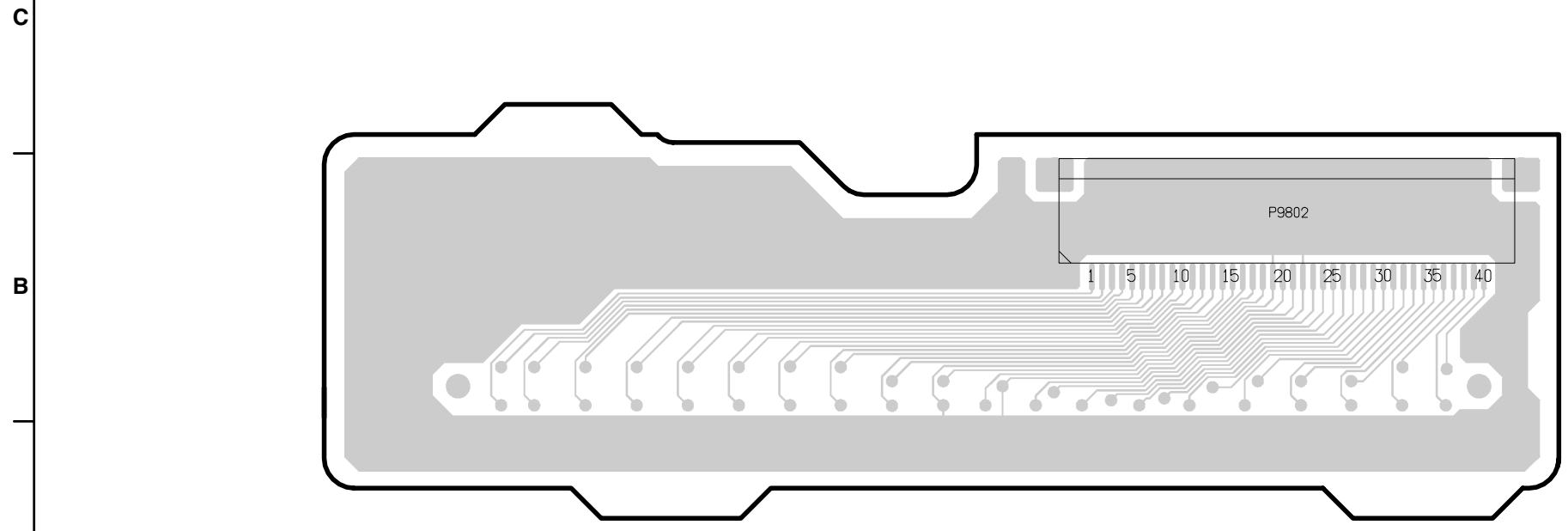

(FOIL SIDE)

DMR-EX98VEB/EC/EG  
ATAPI P.C.B. (VEP70224A)

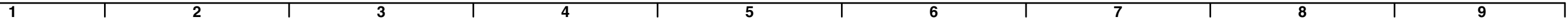

### 13.7. Front Jack P.C.B.

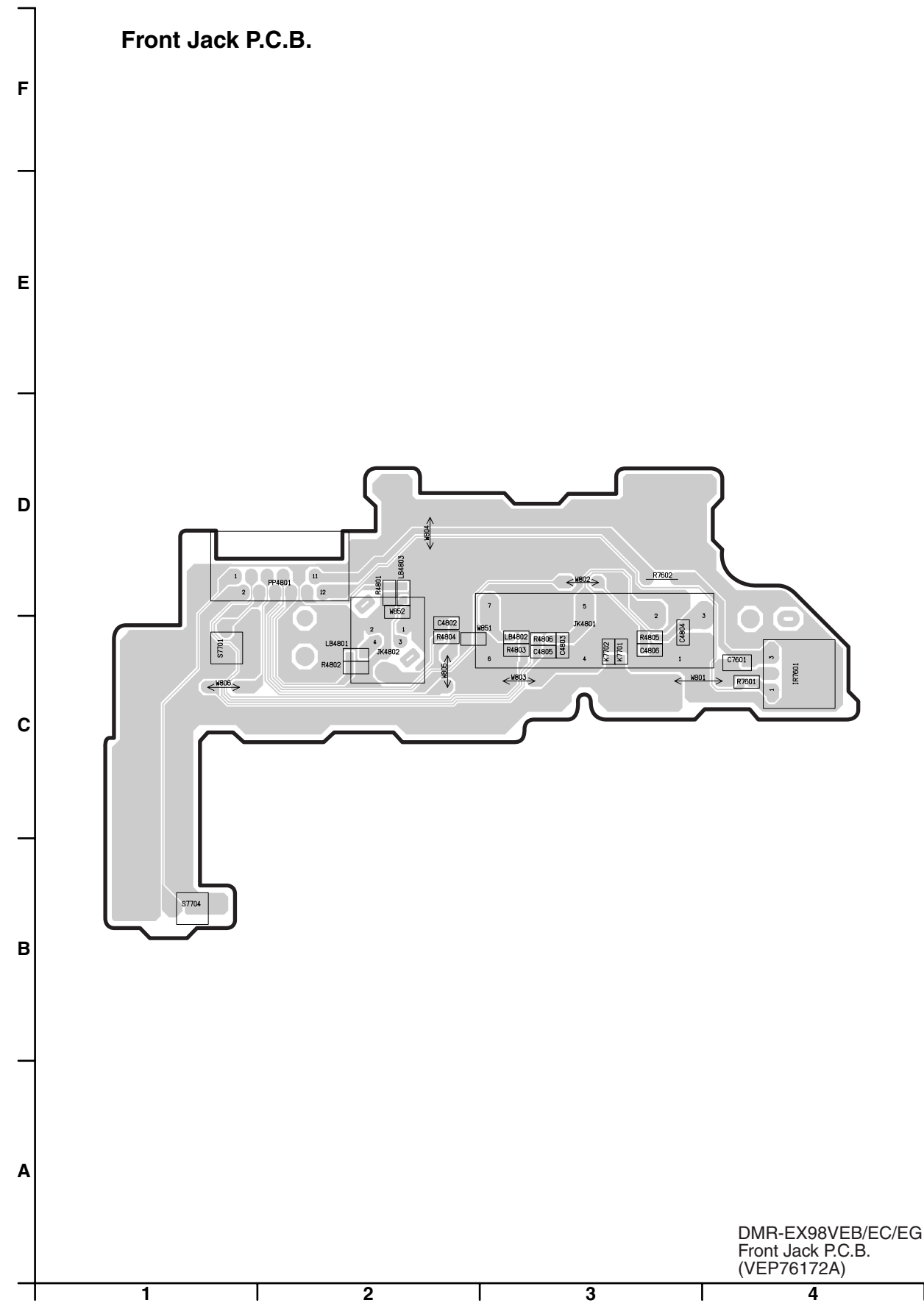



# 14 Appendix for Schematic Diagram

## 14.1. Voltage and Waveform Chart

Note)

Circuit voltage and waveform described herein shall be regarded as reference information when probing defect point, because it may differ from an actual measuring value due to difference of Measuring instrument and its measuring condition and product itself.

### 14.1.1. Dig. Interface P.C.B.

Ref No.	IC9301					IC9302																	
MODE	1	2	3	4	5	1	2	3	4	5	6	7	8										
REC	1.2	0	4.7	5.9	5.0	5.8	5.8	5.8	0	5.8	5.8	5.8	11.6										
PLAY	1.2	0	4.7	5.9	5.0	5.8	5.8	5.8	0	5.8	5.8	5.8	11.6										
STOP	1.2	0	4.7	5.9	5.0	5.8	5.8	5.8	0	5.8	5.8	5.8	11.6										
Ref No.	IC9305								IC9700														
MODE	1	2	3	4	5	6	7	8	1	2	3												
REC	5.8	5.8	5.8	0	5.8	5.8	5.8	11.6	1.7	5.0	0												
PLAY	5.8	5.8	5.8	0	5.8	5.8	5.8	11.6	1.7	5.0	0												
STOP	5.8	5.8	5.8	0	5.8	5.8	5.8	11.6	1.7	5.0	0												
Ref No.	IC9701																						
MODE	1	2	3	4	5	6	7	8	9	10	11	12	13	14	15	16	17	18	19	20			
REC	2.4	4.3	5.0	4.7	0.1	0.1	4.3	0	0	0.8	1.2	4.8	2.0	0	2.0	3.3	4.8	3.3	3.2	0			
PLAY	2.4	4.3	5.0	4.7	0.1	0.1	4.3	0	0	0.8	1.2	4.8	2.0	0	2.0	3.3	4.8	3.3	3.2	0			
STOP	2.4	4.3	5.0	4.7	0.1	0.1	4.3	0	0	0.8	2.0	4.8	2.0	0	2.0	3.3	4.8	3.3	3.2	0			
Ref No.	IC9701																						
MODE	21	22	23	24	25	26	27	28	29	30	31	32	33	34	35	36	37	38	39	40			
REC	3.0	0	3.2	0	3.2	3.2	1.7	3.0	3.8	3.8	3.3	3.3	0	0	0.7	3.2	3.2	3.3	2.5	5.0			
PLAY	3.0	1.3	3.2	0	3.2	3.2	1.7	3.0	3.8	3.8	3.3	3.3	0	0	0.7	3.2	3.2	3.3	2.5	5.0			
STOP	3.0	0	3.2	0	3.2	3.2	1.7	3.0	3.8	3.8	3.3	3.3	0	0	0.7	3.2	3.2	3.3	2.5	5.0			
Ref No.	IC9701																						
MODE	41	42	43	44	45	46	47	48	49	50	51	52	53	54	55	56	57	58	59	60			
REC	4.8	4.8	4.8	4.7	2.9	4.8	4.9	0	-	-	-	-	0	0	0	0	-	0	-	5.0			
PLAY	4.8	4.8	4.8	4.7	2.9	4.8	4.9	0	-	-	-	-	0	0	0	0	-	0	-	5.0			
STOP	4.8	4.8	4.8	4.7	2.9	4.8	4.9	0	-	-	-	-	0	0	0	0	-	0	-	5.0			
Ref No.	IC9701																						
MODE	61	62	63	64	65	66	67	68	69	70	71	72	73	74	75	76	77	78	79	80			
REC	0	4.9	-	0	4.8	0	0	0	-	-	4.7	-	4.7	0	5.0	0	-	0	0	3.9			
PLAY	0	4.9	-	0	4.8	0	0	0	-	-	4.7	-	4.7	0	5.0	0	-	0	0	3.9			
STOP	0	4.9	-	0	4.8	0	0	0	-	-	4.7	-	4.7	0	5.0	0	-	0	0	3.9			
Ref No.	IC9701																						
MODE	81	82	83	84	85	86	87	88	89	90	91	92	93	94	95	96	97	98	99	100			
REC	0	0	0	2.0	0	4.9	4.9	4.9	2.0	4.9	0	0	2.6	1.6	1.2	0	0	1.8	4.9	4.0			
PLAY	0	0	0	2.0	0	4.9	4.9	4.9	2.0	4.9	0	0	2.6	1.6	1.2	0	0	2.1	4.9	4.0			
STOP	0	0	0	2.0	0	4.9	4.9	4.9	2.0	4.9	0	0	2.6	1.6	1.2	0	0	1.9	4.9	4.0			
Ref No.	IC9702					IC9703					IC9705												
MODE	1	2	3	4	5	1	2	3	4	5	1	2	3	4	5	6	7	8					
REC	3.2	3.3	0	-	-	4.9	5.0	0	-	-	0	0	0	0	0	3.2	3.2	0	3.3				
PLAY	3.2	3.3	0	-	-	4.9	5.0	0	-	-	0	0	0	0	0	3.2	3.2	0	3.3				
STOP	3.2	3.3	0	-	-	4.9	5.0	0	-	-	0	0	0	0	0	3.2	3.2	0	3.3				
Ref No.	IC9706					IC9707					IC9708												
MODE	1	2	3	4	5	1	2	3	4	5	1	2	3	4	5								
REC	0	0	0	4.9	4.9	-	0	0	3.0	5.8	5.8	4.7	5.0	1.5	0								
PLAY	0	0	0	4.9	4.9	-	0	0	3.0	5.8	5.8	4.7	5.0	1.5	0								
STOP	0	0	0	4.9	4.9	-	0	0	3.0	5.8	5.8	4.7	5.0	1.5	0								
Ref No.	IC11150					IC11170					IC11200					IC11300							
MODE	1	2	3	4	5	1	2	3	4	5	1	2	3	1	2	3							
REC	3.0	1.5	0	11.6	-	2.2	1.6	0	15.0	-	9.9	2.5	0	4.4	2.5	0							
PLAY	3.0	1.5	0	11.6	-	2.2	1.6	0	15.0	-	9.9	2.5	0	4.4	2.5	0							
STOP	3.0	1.5	0	11.6	-	2.2	1.6	0	15.0	-	9.9	2.5	0	4.4	2.5	0							
Ref No.	IC11370								IC11400														
MODE	1	2	3	4	5	6	7	8	1	2	3	4	5	6	7	8							
REC	12.5	4.5	1.2	1.2	1.2	0	7.9	12.5	-15.3	-	-17.3	-18.6	-14.1	-	-	-14.1							
PLAY	12.5	4.5	1.2	1.2	1.2	0	7.9	12.5	-15.3	-	-17.3	-18.6	-14.1	-	-	-14.1							
STOP	12.5	4.5	1.2	1.2	1.2	0	7.9	12.5	-15.3	-	-17.3	-18.6	-14.1	-	-	-14.1							
Ref No.	IC11700								IC11750														
MODE	1	2	3	4	5	6	7	8	1	2	3	4	5										
REC	12.6	4.5	1.2	1.2	1.2	0	8.8	12.6	3.8	3.8	0	3.3	1.3										
PLAY	12.6	4.5	1.2	1.2	1.2	0	8.8	12.6	3.8	3.8	0	3.3	1.3										
STOP	12.6	4.5	1.2	1.2	1.2	0	8.8	12.6	3.8	3.8	0	3.3	1.3										

Ref No.	Q9101			Q9106			Q9202			Q9203			Q9204					
MODE	E	C	B	E	C	B	E	C	B	E	C	B	E	C	B			
REC	0	5.9	0	3.3	5.8	3.9	0	4.7	0	0	0	4.7	0	5.0	0			
PLAY	0	5.9	0	3.3	5.8	3.9	0	4.7	0	0	0	4.7	0	5.0	0			
STOP	0	5.9	0	3.3	5.8	3.9	0	4.7	0.1	0	0	4.7	0	5.0	0			
Ref No.	Q9301			Q9302			Q9701			Q9702			Q9703					
MODE	E	C	B	E	C	B	E	C	B	E	C	B	E	C	B			
REC	0	0	-0.1	0	0	-0.1	2.7	0	2.1	2.0	5.0	1.6	1.1	11.3	1.6			
PLAY	0	0	-0.1	0	0	-0.1	2.7	0	2.1	2.0	5.0	1.6	1.1	11.3	1.6			
STOP	0	0	-0.1	0	0	-0.1	2.7	0	2.1	2.0	5.0	1.6	1.1	11.3	1.6			
Ref No.	Q9704			Q9705			Q9706			Q9707			Q9708					
MODE	E	C	B	E	C	B	E	C	B	E	C	B	E	C	B			
REC	12.4	7.6	11.3	2.4	0	1.8	1.8	5.0	1.6	0	0	0.8	-15.3	-15.3	-14.8			
PLAY	12.4	7.6	11.3	2.4	0	1.8	1.8	5.0	1.6	0	0	0.8	-15.3	-15.3	-14.8			
STOP	12.4	7.6	11.3	2.4	0	1.8	1.8	5.0	1.6	0	0	0.8	-15.3	-15.3	-14.8			
Ref No.	Q11200				Q11201			Q11270										
MODE	1	2	3	4	E	C	B	1	2	3	4	5	6	7	8			
REC	10.9	9.9	0	1.5	0	9.9	0	12.5	12.5	12.5	6.2	12.3	12.3	12.3	12.3			
PLAY	10.9	9.9	0	1.5	0	9.9	0	12.5	12.5	12.5	6.2	12.3	12.3	12.3	12.3			
STOP	10.9	9.9	0	1.5	0	9.9	0	12.5	12.5	12.5	6.2	12.3	12.3	12.3	12.3			
Ref No.	Q11271						Q11300				Q11370							
MODE	1	2	3	4	5	6	1	2	3	4	1	2	3	4	5	6	7	8
REC	5.0	5.0	2.6	5.1	5.0	5.0	5.4	4.4	0	1.6	12.5	12.5	12.5	7.9	5.1	5.1	5.1	5.1
PLAY	5.0	5.0	2.6	5.1	5.0	5.0	5.4	4.4	0	1.6	12.5	12.5	12.5	7.9	5.1	5.1	5.1	5.1
STOP	5.0	5.0	2.6	5.1	5.0	5.0	5.4	4.4	0	1.6	12.5	12.5	12.5	7.9	5.1	5.1	5.1	5.1
Ref No.	Q11700												QR9301					
MODE	1	2	3	4	5	6							E	C	B			
REC	3.8	3.8	8.8	12.6	3.8	3.8							5.9	-0.1	5.9			
PLAY	3.8	3.8	8.8	12.6	3.8	3.8							5.9	-0.1	5.9			
STOP	3.8	3.8	8.8	12.6	3.8	3.8							5.9	-0.1	5.9			
Ref No.	QR9701			QR9703			QR9705			QR9706			QR9707					
MODE	E	C	B	E	C	B	E	C	B	E	C	B	E	C	B			
REC	0	0	3.2	0	0	4.7	3.2	4.8	3.2	3.2	4.8	3.2	4.9	4.8	0			
PLAY	0	0	3.2	0	0	4.7	3.2	4.8	3.2	3.2	4.8	3.2	4.9	4.8	0			
STOP	0	0	3.2	0	0	4.7	3.2	4.8	3.2	3.2	4.8	3.2	4.9	4.8	0			
Ref No.	QR11200			QR11270			QR11271			QR11700			QR11701					
MODE	E	C	B	E	C	B	E	C	B	E	C	B	E	C	B			
REC	0	0	3.3	0	0	4.9	0	0	4.9	0	0	4.8	0	4.5	0			
PLAY	0	0	3.3	0	0	4.9	0	0	4.9	0	0	4.8	0	4.5	0			
STOP	0	0	3.3	0	0	4.9	0	0	4.9	0	0	4.8	0	4.5	0			

## 14.1.2. Main P.C.B.

Ref No.	IC2501																			
MODE	1	2	3	4	5	6	7	8	9	10	11	12	13	14	15	16	17	18	19	20
REC	12.2	0.1	0	0.1	0	0	16.1	0	2.8	1.6	1.6	0.6	1.5	2.4	2.5	2.5	2.5	1.3	5.0	3.8
PLAY	12.2	0.1	0	0.1	0	0	16.2	0	2.8	1.6	1.6	0.6	1.5	2.4	2.5	2.5	2.5	1.3	5.0	3.6
STOP	12.2	0.1	0	0.1	0	0	16.2	0	2.8	1.6	1.6	0.6	1.5	2.4	2.5	2.5	2.5	1.3	5.0	3.6
Ref No.	IC2501																			
MODE	21	22	23	24	25	26	27													
REC	12.2	3.8	3.8	0	3.8	0	0													
PLAY	12.2	3.6	3.6	0	3.6	0	0													
STOP	12.2	3.6	3.6	0	3.6	0	0													
Ref No.	IC3001																			
MODE	1	2	3	4	5	6	7	8	9	10	11	12	13	14	15	16	17	18	19	20
REC	0	0	0	5.1	2.1	2.6	2.8	1.9	1.9	2.3	2.6	1.5	0	2.8	2.7	0	2.7	2.0	2.7	0
PLAY	0	0	0	5.1	2.1	2.6	2.8	1.9	1.9	2.3	2.6	1.5	0	2.8	2.7	0	2.7	2.0	2.7	0
STOP	0	0	0	5.1	2.1	2.6	2.8	1.9	1.9	2.3	2.6	1.5	0	2.8	2.7	0	2.7	2.0	2.7	0
Ref No.	IC3001																			
MODE	21	22	23	24	25	26	27	28	29	30	31	32	33	34	35	36	37	38	39	40
REC	2.7	5.0	2.3	0	2.1	2.9	0.4	0	2.4	2.8	0.4	2.2	2.0	1.7	3.0	2.3	3.0	2.1	1.4	2.1
PLAY	2.7	5.0	2.3	0	2.1	2.9	0.4	0	2.4	2.8	0.4	2.2	2.0	1.7	3.0	2.3	3.0	2.1	1.4	2.1
STOP	2.7	5.0	2.3	0	2.1	3.0	0.4	0	2.4	2.8	0.4	2.2	2.1	1.7	3.0	2.3	3.0	2.1	1.5	2.1
Ref No.	IC3001																			
MODE	41	42	43	44	45	46	47	48	49	50	51	52	53	54	55	56	57	58	59	60
REC	2.5	2.0	2.1	0	3.2	3.2	5.0	0.1	3.1	5.0	1.9	5.0	2.6	0	1.9	0	2.2	2.2	5.0	5.0
PLAY	2.5	2.0	2.1	0	3.2	3.2	5.0	0.1	3.1	5.0	1.9	5.0	2.6	0	1.9	0	2.2	2.2	5.0	5.0
STOP	2.5	2.0	2.1	0	3.2	3.2	5.0	0.1	3.1	5.0	1.9	5.0	2.6	0	1.9	0	2.2	2.2	5.0	5.0
Ref No.	IC3001																			
MODE	61	62	63	64	65	66	67	68	69	70	71	72	73	74	75	76	77	78	79	80
REC	4.0	2.3	2.2	2.4	2.2	2.4	0	1.2	2.0	2.7	2.2	0.1	4.3	4.3	2.8	2.2	2.8	0	0	2.4
PLAY	4.0	2.3	2.2	2.4	2.2	2.4	0	1.2	2.0	2.7	2.2	0.1	4.3	4.3	2.8	2.2	2.8	0	0	2.4
STOP	4.0	2.3	2.2	2.4	2.2	2.4	0	1.2	0	2.7	2.2	0.1	4.3	4.3	2.7	2.2	2.8	0	0	2.4
Ref No.	IC3001																			
MODE	81	82	83	84	85	86	87	88	89	90	91	92	93	94	95	96	97	98	99	100
REC	4.7	0	3.2	4.9	2.4	2.3	2.4	0	0	0	0	5.1	1.6	2.6	2.5	2.5	0	2.3	0	2.6
PLAY	4.7	0	3.2	4.9	2.4	2.3	2.4	0	0	0	0	5.1	1.6	2.6	2.5	2.5	0	2.3	0	2.6
STOP	4.7	0	3.2	5.0	2.3	2.3	2.3	0	2.3	2.3	2.3	5.1	1.6	2.5	2.5	2.5	0	2.3	0	2.6
Ref No.	IC3002																			
MODE	1	2	3	4	5	6	7	8												
REC	5.1	-	1.3	0	4.8	-	-	5.8												
PLAY	5.1	-	1.3	0	4.8	-	-	5.8												
STOP	5.1	-	1.3	0	4.8	-	-	5.8												
Ref No.	IC3901																			
MODE	1	2	3	4	5	6	7	8	9	10	11	12	13	14	15	16	17	18	19	20
REC	2.0	2.5	1.6	0	1.6	5.0	1.6	5.0	0.4	0.3	1.6	0.4	0	1.7	1.7	1.6	0.4	0	1.7	1.7
PLAY	2.0	2.5	1.6	0	1.6	5.0	1.6	5.0	0.4	0.3	1.6	0.4	0	1.7	1.7	1.6	0.4	0	1.7	1.7
STOP	2.0	2.5	1.6	0	1.6	5.0	1.6	5.0	0.4	1.6	1.6	0.4	0	1.7	1.7	1.6	0.4	0	1.7	1.7
Ref No.	IC3901																			
MODE	21	22	23	24	25	26	27	28	29	30	31	32	33	34	35	36	37	38	39	40
REC	0	1.7	1.7	1.7	5.0	1.4	0.1	1.4	0	1.2	1.6	0	1.6	0	2.1	0	1.6	0	1.6	5.0
PLAY	0	1.7	1.7	1.7	5.0	1.4	0.1	1.4	0	1.2	1.6	0	1.6	0	2.1	0	1.6	0	1.6	5.0
STOP	0	1.7	1.6	1.7	5.0	1.4	0.2	1.4	0	1.2	1.6	0	1.6	0	2.1	0	1.6	0	1.6	5.0
Ref No.	IC3901																			
MODE	41	42	43	44	45	46	47	48	49	50	51	52	53	54	55	56	57	58	59	60
REC	1.6	5.1	2.0	0	2.0	11.6	1.6	2.0	4.5	4.4	4.4	4.0	4.5	1.4	4.5	4.5	9.1	4.4	4.4	4.5
PLAY	1.6	5.1	2.0	0	2.0	11.6	1.6	2.0	4.5	4.4	4.4	4.0	4.5	1.4	4.5	4.5	9.1	4.4	4.4	4.5
STOP	1.6	5.1	2.0	0	2.0	11.6	1.6	2.0	4.5	4.5	4.0	4.5	4.5	1.4	4.5	3.9	9.1	4.0	4.3	3.7
Ref No.	IC3901																			
MODE	61	62	63	64	65	66	67	68	69	70	71	72	73	74	75	76	77	78	79	80
REC	4.5	-	4.5	4.5	9.0	0	-	-	-	-	4.5	4.5	4.5	4.5	0	-	9.5	4.5	4.5	0
PLAY	4.5	-	4.5	4.5	9.0	0	-	-	-	-	4.5	4.5	4.5	4.5	0	-	9.5	4.5	4.5	0
STOP	3.7	-	3.7	3.8	9.0	0	-	-	-	-	4.5	4.5	4.5	4.5	0	-	0.3	4.5	4.5	0
Ref No.	IC3901																			
MODE	81	82	83	84	85	86	87	88	89	90	91	92	93	94	95	96	97	98	99	100
REC	2.1	-	1.5	5.1	2.1	4.5	3.6	4.8	4.6	5.0	2.0	2.8	2.1	5.1	2.0	0	2.1	0	2.0	2.5
PLAY	2.1	-	1.5	5.1	2.1	4.5	3.6	4.8	4.6	5.0	2.0	2.8	2.1	5.1	2.0	0	2.1	0	2.0	2.5
STOP	2.1	-	1.5	5.1	2.1	4.5	3.6	4.8	4.6	5.1	5.0	2.8	2.1	5.1	2.0	0	2.1	0	2.0	2.5
Ref No.	IC3905																			
MODE	1	2	3	4	5	6														
REC	0	2.1	5.0	2.0	0	2.1														
PLAY	0	2.1	5.0	2.0	0	2.1														
STOP	0	2.1	5.0	2.0	0	2.1														
Ref No.	IC4501																			
MODE	1	2	3	4	5	6	7	8	9	10	11	12	13	14	15	16	17	18	19	20
REC	2.3	0	2.3	0	0	2.5	2.1	0	0	0	0	2.1	0	0	0	2.7	0.6	2.6	2.6	2.1
PLAY	2.3	0	2.3	0	0	2.5	2.1	0	0	0	0	2.1	0	0	0	2.7	0.6	2.6	2.6	2.1
STOP	2.3	0	2.3	0	0	2.5	2.1	0	0	0	0	2.1	0	0	0	2.7	0.6	2.6	2.6	2.1
Ref No.	IC4501																			
MODE	21	22	23	24	25	26	27	28	29	30	31	32	33	34	35	36	37	38	39	40
REC	2.0	2.1	0	2.1	5.1	2.1	0	4.3	3.9	3.7	1.1	2.5	2.6	0.8	2.6	0	2.0	0	0	5.1
PLAY	2.0	2.1	0	2.1	5.1	2.1	0	4.3	3.9	3.7	1.1	2.5	2.6	0.8	2.6	0	2.0	0	0	5.1
STOP	2.1	2.1	0	2.1	5.1	2.1	0	4.3	1.8	1.8	0	2.6	2.6	0.8	2.6	0	2.0	0	0	5.1
Ref No.	IC4501																			
MODE	41	42	43	44	45	46	47	48	49	50	51	52	53	54	55	56	57	58	59	60
REC	0	4.3	4.3	3.3	1.6	2.5	2.5	2.5	0.2	0.2	6.0	6.0	5.9	0	0	0	5.9	12.1	6.0	0
PLAY	0	4.3	4.3	3.3	1.6	2.5	2.5	2.5	0.2	0.2	6.0	6.0	5.9	0	0	0	5.9	12.1	6.0	0
STOP	0	4.3	4.3	3.3	1.6	2.5	1.6	2.5	0.2	0.2	6.0	6.0	6.0	0	0	0	6.0	12.1	6.1	0

Ref No.	IC4501																				
MODE	61	62	63	64																	
REC	2.5	2.4	2.5	2.5																	
PLAY	2.5	2.4	2.5	2.5																	
STOP	2.6	2.4	2.5	2.5																	
Ref No.	IC6001																				
MODE	1	2	3	4	5	6	7	8	9	10	11	12	13	14	15	16	17	18	19	20	
REC	-	0	-	0	4.9	0.7	4.8	4.6	3.2	4.9	4.7	0	0	4.9	3.8	-	0	2.4	0	4.8	
PLAY	-	0	-	0	4.9	4.9	4.8	4.6	3.2	4.9	0	0	0	4.9	3.8	-	0	2.4	0	0	
STOP	-	0	-	0	4.9	0.7	4.8	4.6	3.3	4.9	0	0	0	4.9	3.8	-	0	2.4	0	0	
Ref No.	IC6001																				
MODE	21	22	23	24	25	26	27	28	29	30	31	32	33	34	35	36	37	38	39	40	
REC	4.9	0	4.3	-	0	0	0	0	0	0	4.8	4.8	0	4.9	0	0	4.9	-	-	0	
PLAY	0	0	4.3	-	0	0	0	0	0	0	4.8	4.8	0	4.9	0	0	4.9	-	-	0	
STOP	0	0	4.3	-	0	0	0	0	0	0	4.8	4.8	0	4.9	0	0	4.9	-	-	0	
Ref No.	IC6001																				
MODE	41	42	43	44	45	46	47	48	49	50	51	52	53	54	55	56	57	58	59	60	
REC	-	-	4.9	-	0	0	2.0	2.1	0	1.7	5.0	1.7	5.1	2.1	-	2.0	0	4.9	-	-	
PLAY	-	-	4.9	-	0	0	2.0	2.1	0	1.7	5.0	1.7	5.1	2.1	-	2.0	0	4.9	-	-	
STOP	-	-	4.9	-	0	0	2.0	2.1	0	1.7	5.0	1.7	5.1	2.1	-	2.0	0	4.9	-	-	
Ref No.	IC6001																				
MODE	61	62	63	64	65	66	67	68	69	70	71	72	73	74	75	76	77	78	79	80	
REC	0	0	-	-	-	-	-	4.0	2.2	4.2	4.2	4.1	-	0	4.6	2.5	2.4	-	4.8	4.5	
PLAY	0	0	-	-	-	-	-	4.0	2.2	4.2	4.2	4.1	-	0	4.6	2.5	2.4	-	4.8	0.2	
STOP	0	0	-	-	-	-	-	4.0	2.2	4.2	4.2	4.1	-	0	4.6	0	2.4	-	5.0	0.2	
Ref No.	IC6001																				
MODE	81	82	83	84	85	86	87	88	89	90	91	92	93	94	95	96	97	98	99	100	
REC	-	0	-	-	0	2.5	2.5	0	0	1.3	2.5	2.5	0	2.3	2.8	2.5	2.5	5.1	4.9	-	
PLAY	-	0	-	-	0	2.5	2.5	0	0	1.3	2.5	2.5	0	2.3	2.8	2.5	2.5	5.1	4.9	-	
STOP	-	0	-	-	0	2.6	2.6	0	0	1.3	2.5	2.5	0	2.5	2.5	2.5	2.5	5.1	4.9	-	
Ref No.	IC6302				IC6501				IC6502												
MODE	1	2	3	4			1	2	3	4			1	2	3	4					
REC	5.0	0	4.6	5.7			1.2	2.4	0.2	0			0	1.2	4.9	0					
PLAY	5.0	0	4.6	5.7			1.2	2.4	0.1	0			0	1.2	4.9	0					
STOP	5.0	0	4.6	5.7			1.2	2.4	0.2	0			0	1.2	4.9	0					
Ref No.	IC7301																				
MODE	1	2	3	4	5	6	7	8	9	10	11	12	13	14	15	16	17	18	19	20	
REC	3.3	1.7	0	1.7	3.3	3.3	1.7	0	1.7	3.3	1.7	1.7	3.3	1.3	1.5	1.3	1	1.3	0	3.3	
PLAY	3.3	1.7	0	1.7	3.3	3.3	1.7	0	1.7	3.3	1.7	1.7	3.3	1.3	1.5	1.3	1	1.3	0	3.3	
STOP	3.3	1.7	0	1.7	3.3	3.3	1.7	0	1.7	3.3	1.7	1.7	3.3	1.3	1.5	1.4	1	1.3	0	3.3	
Ref No.	IC7301																				
MODE	21	22	23	24	25	26	27	28	29	30	31	32	33	34	35	36	37	38	39	40	
REC	3.3	0	1.5	0	0	1.5	1.5	3.3	0	1.5	3.3	4.2	3.7	3.3	3.3	0	0	0	0	0	
PLAY	3.3	0	1.5	0	0	1.5	1.5	3.3	0	1.5	3.3	4.2	3.7	3.3	3.3	0	0	0	0	0	
STOP	3.3	0	1.5	0	0	1.5	1.5	3.3	0	1.5	3.3	4.2	3.7	3.3	3.3	0	0	0	0	0	
Ref No.	IC7301																				
MODE	41	42	43	44																	
REC	0	0	0	0																	
PLAY	0	0	0	0																	
STOP	0	0	0	0																	
Ref No.	IC7302				IC7303				IC7304												
MODE	1	2	3	4	5		1	2	3	4	5		1	2	3	4	5				
REC	0	0	-	3.3	3.3		3.9	0	4.7	-	3.3		2.6	0	4.7	-	1.5				
PLAY	0	0	-	3.3	3.3		3.9	0	4.7	-	3.3		2.6	0	4.7	-	1.5				
STOP	0	0	-	3.3	3.3		3.9	0	4.7	-	3.3		2.6	0	4.7	-	1.5				
Ref No.	IC7401				IC7402				IC7403												
MODE	1	2	3	4	5		1	2	3	4	5		1	2	3	4	5				
REC	5.8	0	5.8	-	5.0		5.8	0	4.2	-	5.0		1.7	0	4.8	5.8	5.0				
PLAY	5.8	0	5.8	-	5.0		5.8	0	4.2	-	5.0		1.7	0	4.8	5.8	5.0				
STOP	5.8	0	5.8	-	5.0		5.8	0	4.2	-	5.0		1.7	0	4.8	5.8	5.0				
Ref No.	IC7404				IC7801																
MODE	1	2	3	4	5		1	2	3	4	5										
REC	5.8	0	4.2	-	5.0		0	5.8	5.0	-	4.7										
PLAY	5.8	0	4.2	-	5.0		0	5.8	5.0	-	4.7										
STOP	5.8	0	4.2	-	5.0		0	5.8	5.0	-	4.7										
Ref No.	Q3002			Q4001			Q4002			Q4003			Q4004								
MODE	E	C	B		E	C	B		E	C	B		E	C	B		E	C	B		
REC	1.6	5.0	2.2		-19.4	10.4	-28.1		-19.4	0	-28.1		0	5.1	-0.6		5.7	5.6	4.9		
PLAY	1.6	5.0	2.2		0	0	0.7		0	0	0.7		0	0.3	0.3		5.7	0.4	5.7		
STOP	1.6	5.0	2.2		0	0	0.7		0	0	0.7		0	0.3	0.3		5.7	0.4	5.7		
Ref No.	Q4501			Q4502			Q4950			Q4951			Q6102								
MODE	E	C	B		E	C	B		E	C	B		E	C	B		E	C	B		
REC	5.0	5.8	5.6		12.4	12.3	11.7		0	0	-0.1		0	0	-0.1		1.6	5.0	2.2		
PLAY	5.0	5.8	5.6		12.4	12.3	11.7		0	0	-0.1		0	0	-0.1		1.6	5.0	2.2		
STOP	5.0	5.8	5.6		12.4	12.3	11.7		0	0	-0.1		0	0	-0.1		1.6	5.0	2.2		
Ref No.	Q6103			Q6104			Q6305			Q6501			Q6502								
MODE	E	C	B		E	C	B		E	C	B		E	C			E	C			
REC	2.9	5.0	3.6		2.2	0	1.6		5.0	5.8	5.6		0	4.7			0	4.9			
PLAY	2.9	5.0	3.6		2.2	0	1.6		5.0	5.8	5.6		0	4.7			0	4.9			
STOP	2.9	5.0	3.6		2.2	0	1.6		5.0	5.8	5.6		0	4.7			0	4.9			
Ref No.	Q7802			Q7803																	
MODE	E	C	B		E	C	B														
REC	0	5.0	0		0	0	0.8														
PLAY	0	5.0	0		0	0	0.8														
STOP	0	5.0	0		0	0	0.8														

Ref No.	QR4004				QR4005				QR4501				QR4911				QR4912		
MODE	E	C	B		E	C	B		E	C	B		E	C	B		E	C	B
REC	5.1	-28.1	4.8		0	0.1	4.8		0	0	4.6		4.7	4.6	0		0	0	4.6
PLAY	5.1	5.0	0		0	5.7	0		0	0	4.6		4.7	4.6	0		0	0	4.6
STOP	5.1	5.0	0		0	5.7	0		0	0	4.6		4.7	4.6	0		0	0	4.6
Ref No.	QR4913				QR4915				QR7403				QR7404						
MODE	E	C	B		E	C	B		E	C	B		E	C	B				
REC	0	0	4.6		0	4.2	0		0	0	4.8		26.7	26.6	0				
PLAY	0	0	4.6		0	4.2	0		0	0	4.8		26.7	26.6	0				
STOP	0	0	4.6		0	4.2	0		0	0	4.8		26.7	26.6	0				

### 14.1.3. FL Drive P.C.B.

Ref No.	IC7501																			
MODE	1	2	3	4	5	6	7	8	9	10	11	12	13	14	15	16	17	18	19	20
REC	0	4.8	0	0	2.9	0.3	0.3	4.8	4.3	0.1	0.1	0	5.0	-17.8	-17.8	-9.3	-17.8	-20.7	-17.9	-6.5
PLAY	0	4.8	0	0	2.9	0.3	0.3	4.8	4.3	0.1	0.1	0	5.0	-17.8	-17.8	-9.3	-17.8	-20.7	-17.9	-6.5
STOP	0	4.8	0	0	2.9	0.2	0.2	4.8	4.3	0.1	0.1	0	5.0	-20.7	-20.7	-20.7	-17.9	-20.7	-20.7	-20.7
Ref No.	IC7501																			
MODE	21	22	23	24	25	26	27	28	29	30	31	32	33	34	35	36	37	38	39	40
REC	-15.0	0	-9.4	-9.3	-17.8	-20.7	-20.7	-20.7	-12.2	-21.4	-20.9	-20.9	-20.9	-20.9	-20.9	-18.4	-18.1	-18.1	-18.1	-18.1
PLAY	-15.0	0	-9.4	-9.3	-17.8	-20.7	-20.7	-20.7	-12.2	-21.4	-20.9	-20.9	-20.9	-20.9	-20.9	-18.4	-18.1	-18.1	-18.1	-18.1
STOP	-17.9	-15.1	-12.2	-20.7	-20.7	-20.7	-20.7	-20.8	-20.8	-21.4	-21.0	-20.8	-21.0	-21.0	-21.0	-18.4	-18.2	-18.2	-18.2	-18.2
Ref No.	IC7501																Q7502			
MODE	41	42	43	44													E	C	B	
REC	-18.1	-18.1	5.0	0													-18.5	5.0	-18.4	
PLAY	-18.1	-18.1	5.0	0													-18.5	5.0	-18.4	
STOP	-18.2	-18.2	5.0	0													-18.5	5.0	-18.4	
Ref No.	QR7502				QR7503				QR7504				QR7505				QR7506			
MODE	E	C	B		E	C	B		E	C	B		E	C	B		E	C	B	
REC	0	0	4.8		0	5.0	0		0	5.0	0		0	0	4.8		0	5.0	0	
PLAY	0	0	4.8		0	5.0	0		0	5.0	0		0	0	4.8		0	5.0	0	
STOP	0	0	4.8		0	5.0	0		0	5.0	0		0	0	4.8		0	5.0	0	

## 14.1.4. HDMI P.C.B.

Ref No.	IC56103																			
MODE	1	2	3	4	5	6	7	8	9	10	11	12	13	14	15	16	17	18	19	20
REC	-	-	-	-	1.2	-	0	2.8	3.3	0	0	0	3.3	0	0	0	3.3	0	0	0
PLAY	-	-	-	-	1.2	-	0	2.8	3.3	0	0	0	3.3	0	0	0	3.3	0	0	0
STOP	-	-	-	-	1.2	-	0	2.8	3.3	0	0	0	3.3	0	0	0	3.3	0	0	0
Ref No.	IC56103																			
MODE	21	22	23	24	25	26	27	28	29	30	31	32	33	34	35	36	37	38	39	40
REC	3.3	0	0	0	3.3	1.2	0	3.3	-	-	-	-	1.5	3.3	1.3	0	0	1.3	0	3.3
PLAY	3.3	0	0	0	3.3	1.2	0	3.3	-	-	-	-	1.5	3.3	1.3	0	0	1.3	0	3.3
STOP	3.3	0	0	0	3.3	1.2	0	3.3	-	-	-	-	1.5	3.3	1.3	0	0	1.3	0	3.3
Ref No.	IC56103																			
MODE	41	42	43	44	45	46	47	48	49	50	51	52	53	54	55	56	57	58	59	60
REC	1.7	1.2	1.6	0	1.6	0	1.2	0	0	0	0	3.3	0	0	1.2	0	0	0	0	0
PLAY	1.7	1.2	1.6	0	1.6	0	1.2	0	0	0	0	3.3	0	0	1.2	0	0	0	0	0
STOP	1.7	1.2	1.6	0	1.6	0	1.2	0	0	0	0	3.3	0	0	1.2	0	0	0	0	0
Ref No.	IC56103																			
MODE	61	62	63	64	65	66	67	68	69	70	71	72	73	74	75	76	77	78	79	80
REC	0	0	0	-	-	0	0	0	0	3.3	0	0	0	0	1.2	0	0	0	0	0
PLAY	0	0	0	-	-	0	0	0	0	3.3	0	0	0	0	1.2	0	0	0	0	0
STOP	0	0	0	-	-	0	0	0	0	3.3	0	0	0	0	1.2	0	0	0	0	0
Ref No.	IC56103																			
MODE	81	82	83	84	85	86	87	88	89	90	91	92	93	94	95	96	97	98	99	100
REC	0	0	0	3.3	1.2	0	1.8	0.9	1.1	1.4	0	0.8	0.9	0.9	0.9	-	-	-	3.3	3.3
PLAY	0	0	0	3.3	1.2	0	1.8	0.9	1.1	1.4	0	0.8	0.9	0.9	0.9	-	-	-	3.3	3.3
STOP	0	0	0	3.3	1.2	0	1.8	0.9	1.1	1.4	0	0.8	0.9	0.9	0.9	-	-	-	3.3	3.3
Ref No.	IC56103																			
MODE	101	102	103	104	105	106	107	108	109	110	111	112	113	114	115	116	117	118	119	120
REC	0	1.2	0	0	0	3.3	3.3	3.3	1.2	0	1.5	0	3.3	3.3	3.3	1.2	0	0	0	0.1
PLAY	0	1.2	0	0	0	3.3	3.3	3.3	1.2	0	1.5	0	3.3	3.3	3.3	1.2	0	0	0	0.1
STOP	0	1.2	0	0	0	3.3	3.3	3.3	1.2	0	1.5	0	3.3	3.3	3.3	1.2	0	0	0	0.1
Ref No.	IC56103					IC56104					IC56105									
MODE	121	122	123	124	125	126	127	128		1	2	3	4	5		1	2	3	4	5
REC	0.1	0	1.2	3.3	0	-	-	-		4.6	0	3.3	-	3.3		5.7	0	4.8	-	5.0
PLAY	0.1	0	1.2	3.3	0	-	-	-		4.6	0	3.3	-	3.3		5.7	0	4.8	-	5.0
STOP	0.1	0	1.2	3.3	0	-	-	-		4.6	0	3.3	-	3.3		5.7	0	4.8	-	5.0
Ref No.	IC56106					IC56107														
MODE	1	2	3	4	5		1	2	3	4	5									
REC	2.5	3.2	1.2	1.2	0		-	1.6	0	1.5	3.3									
PLAY	2.5	3.2	1.2	1.2	0		-	1.6	0	1.5	3.3									
STOP	2.5	3.2	1.2	1.2	0		-	1.6	0	1.5	3.3									
Ref No.	120			Q56002			Q56101			Q56102			Q56103							
MODE	120	C	B		E	C	B		E	C	B		S	D	G		S	D	G	
REC	0	4.5	0		0	0	0.6		0	3.2	0		0.1	0.1	3.3		0.1	0.1	3.3	
PLAY	0	4.5	0		0	0	0.6		0	3.2	0		0.1	0.1	3.3		0.1	0.1	3.3	
STOP	0	4.5	0		0	0	0.6		0	3.2	0		0.1	0.1	3.3		0.1	0.1	3.3	
Ref No.	Q56104			Q56105																
MODE	E	C	B		E	C	B													
REC	3.4	3.0	3.4		0	3.0	0													
PLAY	3.4	3.0	3.4		0	3.0	0													
STOP	3.4	3.0	3.4		0	3.0	0													

















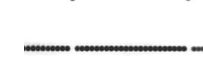





## 14.1.5. P9703 Connector







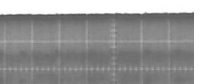









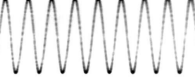
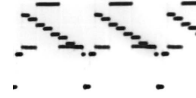
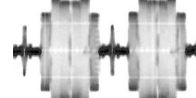

Ref No.	P9703																			
MODE	1	2	3	4	5	6	7	8	9	10	11	12	13	14	15	16	17	18	19	20
REC	3.3	0	0	0	3.3	0	0	0	0	0	0	0	3.3	12.3	2.4	12.3	3.3	0	0.2	0
PLAY	3.3	0	0	0	3.3	0	0	0	0	0	0	0	3.3	12.3	2.4	12.3	3.3	0	0.2	0
STOP	3.3	0	0	0	3.3	0	0	0	0	0	0	0	3.3	12.3	2.4	12.3	3.3	0	0.2	0
Ref No.	P9703																			
MODE	21	22	23	24	25	26	27	28	29	30	31	32	33	34	35	36	37	38	39	40
REC	3.3	5.1	3.3	5.1	5.0	3.3	2.3	3.1	2.5	4.9	2.5	3.3	0	3.3	0	3.3	0	3.3	2.5	0
PLAY	3.3	5.1	3.3	5.1	5.0	3.3	2.3	3.1	2.5	4.9	2.5	3.3	0	3.3	0	3.3	0	3.3	2.5	0
STOP	3.3	5.1	3.3	5.1	5.0	3.3	0	3.2	2.5	4.9	2.5	3.3	0	3.3	0	3.3	0	3.3	2.5	0
Ref No.	P9703																			
MODE	41	42	43	44	45	46	47	48	49	50	51	52	53	54	55	56	57	58	59	60
REC	2.5	3.2	0	1.7	0	0	0	3.3	0	3.3	1.1	5.0	0	0.3	1.5	3.3	0	0	1.0	3.8
PLAY	2.5	3.2	0	1.7	0	0	0	3.3	0	3.3	1.1	5.0	0	0.3	1.5	3.3	0	0	1.0	3.8
STOP	2.5	3.2	0	1.7	0	0	0	3.3	0	3.3	1.1	5.0	0	0.3	1.5	3.3	0	0	1.0	3.8
Ref No.	P9703																			
MODE	61	62	63	64	65	66	67	68	69	70	71	72	73	74	75	76	77	78	79	80
REC	0	3.8	1.1	12.3	0	12.3	1.0	12.3	0	12.3	1.3	12.3	0	12.3	2.1	5.0	0	0	-	0
PLAY	0	3.8	1.1	12.3	0	12.3	1.0	12.3	0	12.3	1.3	12.3	0	12.3	2.1	5.0	0	0	-	0
STOP	0	3.8	1.1	12.3	0	12.3	1.0	12.3	0	12.3	1.3	12.3	0	12.3	2.1	5.0	0	0	-	0
Ref No.	P9703																			
MODE	81	82	83	84	85	86	87	88												
REC	0	0	0	0.3	0	0	0	0												
PLAY	0	0	0	0.3	0	0	0	0												
STOP	0	0	0	0.3	0	0	0	0												

### 14.1.6. P7401, P7402 Connectors

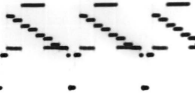
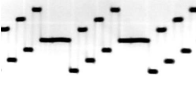
Ref No.	P7401																			
MODE	1	2	3	4	5	6	7	8	9	10	11									
REC	0	0	0	0	0.7	0	0.2	0	5.7	0	5.7									
PLAY	0	0	0	0	0.7	0	0.2	0	5.7	0	5.7									
STOP	0	0	0	0	0.7	0	0.2	0	5.7	0	5.7									
Ref No.	P7402																			
MODE	1	2	3	4	5	6	7	8	9	10										
REC	3.0	2.9	1.7	3.1	3.0	3.2	3.2	0	11.6	0										
PLAY	3.0	2.9	1.7	3.1	3.0	3.2	3.2	0	11.6	0										
STOP	3.0	2.9	1.7	3.1	3.0	3.2	3.2	0	11.6	0										

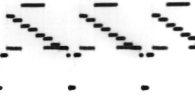
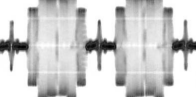
## 14.1.7. Waveform Chart

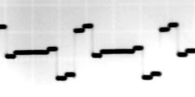
 IC6001-18(TW2001) REC 5.0Vp-p (10msec.div.)	 IC6001-19 PLAY 5.0Vp-p (5msec.div.)	 IC6001-50 REC/PLAY 2.2Vp-p (20usec.div.)	 IC6001-52 REC/PLAY 2.2Vp-p (20usec.div.)	 IC6001-79 FF/REW 5.0Vp-p (1msec.div.)
 IC6001-80 FF/REW 5.0Vp-p (1msec.div.)	 IC6001-86(TL2015) PLAY 0.7Vp-p (0.5msec.div.)	 IC6001-90 REC 5.0Vp-p (10msec.div.)	 IC6001-94 REC 2.4Vp-p (10msec.div.)	 IC6001-95 REC 2.4Vp-p (10msec.div.)
 IC6001-97(TW2002) PLAY 4.4Vp-p (5msec.div.)				
 IC2501-22,23,25 PLAY 8.0Vp-p (2msec.div.)				
 IC3001-6 REC/PLAY 0.9Vp-p (2msec.div.)	 IC3001-19 REC 1.0Vp-p (20usec.div.)	 IC3001-29 REC/PLAY 2.4Vp-p (20usec.div.)	 IC3001-36 PLAY 0.5Vp-p (20usec.div.)	 IC3001-57 REC/PLAY 0.2Vp-p (20usec.div.)
 IC3001-67 PLAY 0.5Vp-p (0.5usec.div.)	 IC3001-80 REC/PLAY 0.5Vp-p (10msec.div.)	 IC3001-86 REC 1.4Vp-p (20usec.div.)	 IC3001-98 REC 1.5Vp-p (1msec.div.)	
 IC4501-21(TW4501) REC 1.1Vp-p (20usec.div.)	 IC4501-53 REC/PLAY 1.6Vp-p (0.5msec.div.)	 IC4501-57 REC/PLAY 1.6Vp-p (0.5msec.div.)		

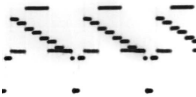
 IC11150-5 STOP 400Vp-p (20usec.div)	 IC11170-5 STOP 520Vp-p (50usec.div)	 T11150-1 STOP 10Vp-p (20msec.div)	 T11150-4 STOP 40Vp-p (20usec.div)	 T11150-9 STOP 38Vp-p (10usec.div)
 T11170-1 STOP 10Vp-p (20msec.div)	 T11170-8 STOP 46Vp-p (50usec.div)	 T11170-12 STOP 110Vp-p (50usec.div)	 T11170-13 STOP 38Vp-p (50usec.div)	 T11170-15 STOP 20Vp-p (50usec.div)
 P9703-29,30 REC/PLAY 0.8Vp-p (1msec.div)	 P9703-51 REC/PLAY 1.0Vp-p (20usec.div.)	 P9703-55 REC/PLAY 0.8Vp-p (20usec.div.)	 P9703-59 REC/PLAY 0.6Vp-p (20usec.div)	 T11170-18 STOP 64Vp-p (50usec.div)
 P9703-63 REC/PLAY 1.0Vp-p (20usec.div.)	 P9703-67 REC/PLAY 0.6Vp-p (20usec.div.)	 P9703-71 REC/PLAY 1.0Vp-p (20usec.div)		
 JK4901-3 REC/PLAY 2.0Vp-p (20usec.div)	 JK4901-4 REC/PLAY 1.5Vp-p (20usec.div)	 JK4901-13 REC/PLAY 2.0Vp-p (20usec.div)		
 JK4901-14 REC/PLAY 1.0Vp-p (20usec.div)	 JK4901-11 REC/PLAY 1.0Vp-p (20usec.div)	 JK4901-8 REC/PLAY 2.0Vp-p (20usec.div)		

## 14.2. Abbreviations

### 14.2.1. DVD

INITIAL/LOGO	ABBREVIATIONS
A	A0~UP ACLK AD0~UP ADATA ALE AMUTE AREQ ARF ASI ASO ASYNC ADDRESS AUDIO CLOCK ADDRESS BUS AUDIO PES PACKET DATA ADDRESS LATCH ENABLE AUDIO MUTE AUDIO PES PACKET REQUEST AUDIO RF SERVO AMP INVERTED INPUT SERVO AMP OUTPUT AUDIO WORD DISTINCTION SYNC
B	BCK BCKIN BDO BLKCK BOTTOM BYP BYTCK BIT CLOCK (PCM) BIT CLOCK INPUT BLACK DROP OUT SUB CODE BLOCK CLOCK CAP. FOR BOTTOM HOLD BYPATH BYTE CLOCK
C	CAV CBDO CD CDSCK CDSRDATA CDRF CDV CHNDATA CKSL CLV COFTR CPA CPCS CPDT CPUADR CPUADT CPUIRQ CPRD CPWR CS CSYNCIN CSYNCOUT CONSTANT ANGULAR VELOCITY CAP. BLACK DROP OUT COMPACT DISC CD SERIAL DATA CLOCK CD SERIAL DATA CD RF (EFM) SIGNAL COMPACT DISC-VIDEO CHANNEL DATA SYSTEM CLOCK SELECT CONSTANT LINEAR VELOCITY CAP. OFF TRACK CPU ADDRESS CPU CHIP SELECT CPU DATA CPU ADDRESS LATCH CPU ADDRESS DATA BUS CPU INTERRUPT REQUEST CPU READ ENABLE CPU WRITE ENABLE CHIP SELECT COMPOSITE SYNC IN COMPOSITE SYNC OUT
D	DACCK DEEMP DEMPH DIG0~UP DIN DMSRCK DMUTE DO DOUT0~UP DRF DRPOUT DREQ DRESP DSC DSLIF DVD D/A CONVERTER CLOCK DEEMPHASIS BIT ON/OFF DEEMPHASIS SWITCHING FL DIGIT OUTPUT DATA INPUT DM SERIAL DATA READ CLOCK DIGITAL MUTE CONTROL DROP OUT DATA OUTPUT DATA SLICE RF (BIAS) DROP OUT SIGNAL DATA REQUEST DATA RESPONSE DIGITAL SERVO CONTROLLER DATA SLICE LOOP FILTER DIGITAL VIDEO DISC

INITIAL/LOGO	ABBREVIATIONS
E	EC ECR ENCSEL ETMCLK ETSCLK ERROR TORQUE CONTROL ERROR TORQUE CONTROL REFERENCE ENCODER SELECT EXTERNAL M CLOCK (81MHz/40.5MHz) EXTERNAL S CLOCK (54MHz)
F	FBAL FCLK FE FFI FEO FG FSC FSCK FOCUS BALANCE FRAME CLOCK FOCUS ERROR FOCUS ERROR AMP INVERTED INPUT FOCUS ERROR AMP OUTPUT FREQUENCY GENERATOR FREQUENCY SUB CARRIER FS (384 OVER SAMPLING) CLOCK
G	GND COMMON GROUNDING (EARTH)
H	HA0~UP HD0~UP HINT HRXW HOST ADDRESS HOST DATA HOST INTERRUPT HOST READ/WRITE
I	IECOUT IPFRAG IREF ISEL IEC958 FORMAT DATA OUTPUT INTERPOLATION FLAG I (CURRENT) REFERENCE INTERFACE MODE SELECT
L	LDON LPC LRCK LASER DIODE CONTROL LASER POWER CONTROL L CH/R CH DISTINCTION CLOCK
M	MA0~UP MCK MCKI MCLK MDATA MDQ0~UP MDQM MLD MPEG MEMORY ADDRESS MEMORY CLOCK MEMORY CLOCK INPUT MEMORY SERIAL COMMAND CLOCK MEMORY SERIAL COMMAND DATA MEMORY DATA INPUT/OUTPUT MEMORY DATA I/O MASK MEMORY SERIAL COMMAND LOAD MOVING PICTURE EXPERTS GROUP
O	ODC OFTR OSCI OSCO OSD OPTICAL DISC CONTROLLER OFF TRACKING OSCILLATOR INPUT OSCILLATOR OUTPUT ON SCREEN DISPLAY
P	P1~UP PCD PCK PDVD PEAK PLLCLK PLLOK PWMCTL PWMDA PWMOA, B PORT CD TRACKING PHASE DIFFERENCE PLL CLOCK DVD TRACKING PHASE DIFFERENCE CAP. FOR PEAK HOLD CHANNEL PLL CLOCK PLL LOCK PLL LOCK PWM OUTPUT CONTROL PULSE WAVE MOTOR DRIVE A PULSE WAVE MOTOR OUT A, B

INITIAL/LOGO		ABBREVIATIONS
R	RE	READ ENABLE
	RFENV	RF ENVELOPE
	RFO	RF PHASE DIFFERENCE OUTPUT
	RS	(CD-ROM) REGISTER SELECT
	RSEL	RF POLARITY SELECT
	RST	RESET
	RSV	RESERVE
S	SBI0, 1	SERIAL DATA INPUT
	SBO0	SERIAL DATA OUTPUT
	SBT0, 1	SERIAL CLOCK
	SCK	SERIAL DATA CLOCK
	SCKR	AUDIO SERIAL CLOCK RECEIVER
	SCL	SERIAL CLOCK
	SCLK	SERIAL CLOCK
	SDA	SERIAL DATA
	SEG0~UP	FL SEGMENT OUTPUT
	SELCLK	SELECT CLOCK
	SEN	SERIAL PORT ENABLE
	SIN1, 2	SERIAL DATA IN
	SOUT1, 2	SERIAL DATA OUT
	SPDI	SERIAL PORT DATA INPUT
	SPDO	SERIAL PORT DATA OUTPUT
	SPEN	SERIAL PORT R/W ENABLE
	SPRCLK	SERIAL PORT READ CLOCK
	SPWCLK	SERIAL PORT WRITE CLOCK
	SQCK	SUB CODE Q CLOCK
	SQCX	SUB CODE Q DATA READ CLOCK
	SRDATA	SERIAL DATA
	SRMADR	SRAM ADDRESS BUS
	SRMDT0~7	SRAM DATA BUS 0~7
	SS	START/STOP
	STAT	STATUS
	STCLK	STREAM DATA CLOCK
	STD0~UP	STREAM DATA
	STENABLE	STREAM DATA INPUT ENABLE
	STSEL	STREAM DATA POLARITY SELECT
	STVALID	STREAM DATA VALIDITY
	SUBC	SUB CODE SERIAL
SBCK	SUB CODE CLOCK	
SUBQ	SUB CODE Q DATA	
SYSCLK	SYSTEM CLOCK	
T	TE	TRACKING ERROR
	TIBAL	BALANCE CONTROL
	TID	BALANCE OUTPUT 1
	TIN	BALANCE INPUT
	TIP	BALANCE INPUT
	TIS	BALANCE OUTPUT 2
	TPSN	OP AMP INPUT
	TPSO	OP AMP OUTPUT
	TPSP	OP AMP INVERTED INPUT
	TRCRS	TRACK CROSS SIGNAL
	TRON	TRACKING ON
	TRSON	TRAVERSE SERVO ON

INITIAL/LOGO		ABBREVIATIONS
V	VBLANK	V BLANKING
	VCC	COLLECTOR POWER SUPPLY VOLTAGE
	VCDCONT	VIDEO CD CONTROL (TRACKING BALANCE)
	VDD	DRAIN POWER SUPPLY VOLTAGE
	VFB	VIDEO FEED BACK
	VREF	VOLTAGE REFERENCE
	VSS	SOURCE POWER SUPPLY VOLTAGE
W	WAIT	BUS CYCLE WAIT
	WDCK	WORD CLOCK
	WEH	WRITE ENABLE HIGH
	WSR	WORD SELECT RECEIVER
X	X	X' TAL
	XALE	X ADDRESS LATCH ENABLE
	XAREQ	X AUDIO DATA REQUEST
	XCDROM	X CD ROM CHIP SELECT
	XCS	X CHIP SELECT
	XCSYNC	X COMPOSITE SYNC
	XDS	X DATA STROBE
	XHSYNCO	X HORIZONTAL SYNC OUTPUT
	XHINT	XH INTERRUPT REQUEST
	XI	X' TAL OSCILLATOR INPUT
	XINT	X INTERRUPT
	XMW	X MEMORY WRITE ENABLE
	XO	X' TAL OSCILLATOR OUTPUT
	XRE	X READ ENABLE
	XSRMCE	X SRAM CHIP ENABLE
	XSRMOE	X SRAM OUTPUT ENABLE
	XSRMWE	X SRAM WRITE ENABLE
	XVCS	X V-DEC CHIP SELECT
	XVDS	X V-DEC CONTROL BUS STROBE
XVSYNCO	X VERTICAL SYNC OUTPUT	

## 14.2.2. VHS

443NT [L]	4.43 NTSC (L)	BIL	BILINGUAL
A. COMP	AUDIO COMPONENT SIGNAL	BIL [L]	BILINGUAL (L)
A. COMPO	AUDIO COMPONENT SIGNAL	BIL. [H]	BILINGUAL (H)
A. D.P [L]	AUDIO DUBBING PAUSE (L)	BIL/M1 [L]	BILINGUAL (L)
A. D/L [L]	AUDIO DUBBING PAUSE (L)	BS CLOCK	BS CLOCK
A. DEF [S]	AUDIO DEFEAT	BS DATA	BS DATA
A. DEF [S] [L]	AUDIO DEFEAT	BS LCH IN	BS L CHANNEL INPUT
A. DUB P [L]	AUDIO DUBBING PAUSE (L)	BS MIX [H]	BS MIX (H)
A. DUB [H]	AUDIO DUBBING (H)	BS MON [H]	BS MONITOR (H)
A. ERASE	AUDIO ERASE	BS MONI [H]	BS MONITOR (H)
A. H. SW	AUDIO HEAD SWITCHING PULSE	BS RCH IN	BS R CHANNEL INPUT
A. HEAD [R]	AUDIO HEAD (REC)	BS VIDEO	BS VIDEO SIGNAL
A. HEAD [W]	AUDIO HEAD (PLAY)	BS VIDEO/BS1	BS VIDEO SIGNAL
A. IN [L]	AUDIO INPUT (L)	BS [H]	BS (H)
A. IN [R]	AUDIO INPUT (R)	BS. LEVEL	BS LEVEL
A. MUT [H]	AUDIO MUTE (H)	BS. M [H]	BS MONITOR (H)
A. MUTE [H]	AUDIO MUTE (H)	BS/VTR [H]	BS/VTR (H)
A. OUT [L]	AUDIO OUTPUT (L)	BUS CLK	BUS CLOCK
A. OUT [R]	AUDIO OUTPUT (R)	BUS LSN	BUS LISTEN
A. RF OUT	AUDIO RF SIGNAL OUTPUT	BUS TLK	BUS TALK
A/VS/S. DATA	AV SW/SERIAL DATA	BUZZER	BUZZER
AC ONLINE	AC ONLINE	CAP EC	CAPSTAN TORQUE CONTROL
AC. O/EE. H	AC ONLINE/EE (H)	CAP M GND	CAPSTAN MOTOR GND
AFC S C	AFC S CURVE	CAP. ET	CAPSTAN TORQUE CONTROL
AFC [S]	AFC S CURVE	CAP. FG1	CAPSTAN FG1 PULSE
AFC. DEF	AFC DEFEAT	CAP. FG2	CAPSTAN FG2 PULSE
ARFC OUT	AUDIO RF SIGNAL OUTPUT	CAS. SW	CASSETTE SW
ART. V	ARTIFICIAL VERTICAL SYNC SIGNAL	CCN	PLAYBACK CONTROL SIGNAL (-)
ART. V. MM	ARTIFICIAL VERTICAL SYNC SIGNAL MONO MULTI	CCP	PLAYBACK CONTROL SIGNAL (+)
ART. V/H/N	ARTIFICIAL VERTICAL SYNC SIGNAL (H)/NORMAL	CHM	CONTROL SIGNAL (+)
AT. V/H/N	ARTIFICIAL VERTICAL SYNC SIGNAL TEST/NORMAL/SERVICE	CHP	CONTROL SIGNAL (-)
ATSW/TEST/NOR/SE	TEST/NORMAL/SERVICE	CINEM [L]	CINEMA (L)
AUDIO IN [L]	AUDIO INPUT (L)	CINEMA [L]	CINEMA (L)
AUDIO IN [R]	AUDIO INPUT (R)	CINEMA/MIX	CINEMA/MIX
AUDIO OUT [L]	AUDIO OUTPUT (L)	CKL	RATCH LOCK
AUDIO OUT [R]	AUDIO OUTPUT (R)	CKS	SHIFT LOCK
AUDIO SELECT [H]	AUDIO SELECT (H)	CL	CLOCK
AUDIO. L	AUDIO (L)	CLK	CLOCK
AUDIO. R	AUDIO (R)	CLK (C.G)	CLOCK
AV CNT	AV CONTROL	CLOCK. IN	CLOCK INPUT
AV CTL	AV CONTROL	CLP	CLAMP
AV CTL/S. CLK	AV CONTROL/SERIAL CLOCK	COL/B/W/NOR	COLOUR/BLACK & WHITE/NORMAL
AV. C.M.	AV CONTROL MODE	COLOR [H]	COLOUR (H)
AVCNT/METER. R	AV CONTROL/LEVEL METER (R)	CONV	CONVERTOR
AVSW/METER. L	AV SW/LEVEL METER (L)	CS	CHIP SELECT
B MODE. H	B MODE (H)	CTL GND	CONTROL GND
B.G.P	BURST GATE PULSE	CTL HEAD [+]	CONTROL HEAD (+)
BACKUP 5V	BACK UP 5V	CTL HEAD [-]	CONTROL HEAD (-)
BAND. U.E.	BAND U	CTL [+]	CONTROL HEAD (+)
BANDVL. D	BAND VL	CTL [-]	CONTROL HEAD (-)
BI/MI [L]	BILINGUAL/MIX (L)	CUE BIAS	CUE BIAS
		CURRENT LIM	CURRENT LIMMITER
		CYL ET	CYLINDER TORQUE CONTROL

CYL GND	CYLINDER GND	FULL. E. 12V	FULL ERASE 12V
D.F.M. REC [H]	DELAIED FM RECORDING $\text{\textcircled{H}}$	GND [A]	GND (ANALOG)
D. FM REC [L]	DELAIED FM RECORDING $\text{\textcircled{L}}$	GND [TU]	GND (TUNER)
D. GND	DIGITAL GND	GND/N. SW. 12V	GND/NON SW 12V
D. REC [H]	DELAYED RECORDING $\text{\textcircled{H}}$	H. SYNC	HORIZONTAL SYNC
D4/S. LED	D4/STILL LED	H. AMP. SW	HEAD AMP SW PULSE
D4/STILLED	D4/STILL LED	H. P <R>	HEAD PHONE (R)
DAC [CLK]	TUNER DAC (CLOCK)	H. P <L>	HEAD PHONE (L)
DAC/FSCS	TUNER DAC/FS CHIP SELECT	H. P GND	HEAD PHONE GND
DAREC [H]	DELAYED AUDIO RECORDING $\text{\textcircled{H}}$	H. P OUT [L]	HEAD PHONE OUTPUT (L)
DATA	DATA	H. P OUT [R]	HEAD PHONE OUTPUT (R)
DECODER [L]	DECODER (L)	H. SW	HEAD SW PULSE
DECODER [R]	DECODER (R)	HEAD PHONE [L]	HEAD PHONE (L)
DEW	DEW	HEAD PHONE [R]	HEAD PHONE (R)
DEW SNS	DEW SENSOR	HEAD SW	HEAD SW
DFMRE [H]	DELAYED FM AUDIO RECORDING $\text{\textcircled{H}}$	HEATER [+]	HEATER (+)
E. REC 5V	EXCEPT RECORDING 5V	HEATER [-]	HEATER (-)
EC	ERROR TORQUE CONTROL	HSS	HORIZONTAL SYNC SIGNAL
ECR	ERROR TORQUE CONTROL	HTR [+]	HEATER (+)
	REFERENCE VOLTAGE	HTR [-]	HEATER (-)
EDT TRIG [L]	EDIT TRIGGER $\text{\textcircled{L}}$	I RFE	REFERENCE CURRENT
EDIT [H]	EDIT $\text{\textcircled{H}}$	ICL	CONTROL AGC CIRCUIT
EE [H]	EE $\text{\textcircled{H}}$	IF	INTERMEDIATE FREQUENCY
EE [H]/INS [M]	EE $\text{\textcircled{H}}$ /INSERT $\text{\textcircled{M}}$	IN SELA1	INPUT SELECT A1 POSITION
EE. VV. TR	EE/VV/TRICK PLAY	IN SELA2	INPUT SELECT A2 POSITION
EJECT. PO	EJECT POSITION	IN SELA3	INPUT SELECT A3 POSITION
EJECT/VDET	EJECT/REVERSE SLOW LOCK	INS L/R [L]	INSERT Lch/Rch $\text{\textcircled{L}}$
ENV. SEL	ENVELOPE SELECT	INS. [H]	INSERT $\text{\textcircled{H}}$
ENVE. OUT	ENVELOPE OUTPUT	INSEL A1	INPUT SELECT A1 POSITION
ENVE. SEL	ENVELOPE SELECT	INSEL A2	INPUT SELECT A2 POSITION
ENV SELECT	ENVELOPE SELECT	INSERT	INSERT
EP [H]	LP $\text{\textcircled{H}}$	INSERT [H]	INSERT $\text{\textcircled{H}}$
EP/LP [H]	LP $\text{\textcircled{H}}$	IO CS	INPUT/OUTPUT CHIP SELECT
EP/LP/SP	LP/SP	JOG1	JOG1
EP/SS [H]	LP/SLOW/STILL/STOP $\text{\textcircled{H}}$	JOG S3 LED/FOWRD	JOG LED/FORWARD LED
EPROMCS	EPROM CHIP SELECT	JOG/F. LED	JOG LED/FORWARD LED
EX. REC 5V	EXCEPT RECORDING 5V	JSB [H]	JSB $\text{\textcircled{H}}$
FF/REW [L]	FIRST FORWARD/REWIND $\text{\textcircled{L}}$	JST. CLCK	JUST CLOCK
FG1 IN	FG1 PULSE INPUT	JST. CLK	JUST CLOCK
FG2 IN	FG2 PULSE INPUT	JST. CLOCK	JUST CLOCK
FILTER ADJUSTMENT	FILTER ADJUSTMENT	L. OUT	Lch OUTPUT
FLY ERASE [H]	FLYING ERASE HEAD ON $\text{\textcircled{H}}$	L. CH [H]	Lch $\text{\textcircled{H}}$
FLY ON [H]	FLYING ERASE HEAD ON $\text{\textcircled{H}}$	L. CH [L]	Lch $\text{\textcircled{L}}$
FLY. E [H]	FLYING ERASE HEAD ON $\text{\textcircled{H}}$	LED (MAIN)	LED (MAIN)
FM MUT [H]	FM AUDIO MUTE $\text{\textcircled{H}}$	LED (STEREO)	LED (STEREO)
FM MUTE [H]	FM AUDIO MUTE $\text{\textcircled{H}}$	LED (SUB)	LED (SUB)
FM OUT [L]	FM OUTPUT (L)	LED CKL	LED SERIAL CLOCK
FM OUT [R]	FM OUTPUT (R)	LED CKS	LED SERIAL CLOCK
FM PACK OUT [L]	FM PACK OUTPUT (L)	LED DATA	LED SERIAL DATA
FM PACK OUT [R]	FM PACK OUTPUT (R)	LINE IN 1 [L]	LINE INPUT 1 (L)
FM/BS SEL [L]	FM/BS SELECT (L)	LINE IN 1 [R]	LINE INPUT 1 (R)
FM/BS SEL [R]	FM/BS SELECT (R)	LINE IN 2 [L]	LINE INPUT 2 (L)
FS. CLK	FS CLOCK	LINE IN 2 [R]	LINE INPUT 2 (R)
FUL. E [H]	FULL ERASE HEAD ON $\text{\textcircled{H}}$	LINE IN V	LINE INPUT VIDEO
FULL. E [H]	FULL ERASE HEAD ON $\text{\textcircled{H}}$	LINE IN [L]	LINE INPUT (L)

LINE IN [R]	LINE INPUT (R)	P-OFF [H]	POWER OFF $\text{\textcircled{H}}$
LINE OUT [L]	LINE OUTPUT (L)	P-OFF [L]	POWER OFF $\text{\textcircled{L}}$
LINE OUT [R]	LINE OUTPUT (R)	P. FAIL	POWER FAILURE DETECT
LP [H]	LP $\text{\textcircled{H}}$	P. OFF [H]	POWER OFF $\text{\textcircled{H}}$
LPTRI [L]	LP TRICK PLAY $\text{\textcircled{L}}$	P. OFF [L]	POWER OFF $\text{\textcircled{L}}$
Lch/A. DUB	Lch/AUDIO DUBBING	PAL [H]	PAL $\text{\textcircled{H}}$
M GND	MOTOR GND	PAL [L]/NTSC [H]	PAL $\text{\textcircled{L}}$ /NTSC $\text{\textcircled{H}}$
M REG	MOTOR REGULATOR	PB ADJ OUT	PLAYBACK ADJUST OUTPUT
MAIN OUT	MAIN OUTPUT	PB OUT	PLAYBACK OUTPUT
MAIN [L]	MAIN $\text{\textcircled{L}}$	PB. H	PLAYBACK $\text{\textcircled{H}}$
MAIN/MONO	MAIN/MONAUROAL	PGF	PG/FG
MAX IN	MAXIMAM INPUT	PHOTSN +B	PHOTO SENSOR +B
MES [H]	MESECAM $\text{\textcircled{H}}$	PICT. CNT	PICTURE CONTROL
MESE [H]	MESECAM $\text{\textcircled{H}}$	PLAY LED/RVS LED	PLAY LED/REVERSE LED
MESE [L]	MESECAM $\text{\textcircled{L}}$	PLAY. PO	PLAY POSITION
METER 5V	LEVEL METER 5V	PLAY/R. LED	PLAY LED/REVERSE LED
METER [L]	LEVEL METER (L)	PLY/DEW	PLAY/DEW $\text{\textcircled{H}}$
METER [R]	LEVEL METER (R)	POWER OFF [L]	POWER OFF $\text{\textcircled{L}}$
METER. L/AVS	LEVEL METER (L)	PREROLL [H]	PREROLL $\text{\textcircled{H}}$
METER. R/AVC	LEVEL METER (R)	PWRFAIL	POWER FAILURE DETECT
M/BI [L]	MIX $\text{\textcircled{H}}$ /BILIGUAL	R. CH [H]	Rch $\text{\textcircled{H}}$
MIC GND	MIC GND	R. CH [L]	Rch $\text{\textcircled{L}}$
MIC IN	MIC INPUT	R. ST	RESET
MIC IN [L]	MIC INPUT (L)	R/S/F	REVERSE $\text{\textcircled{H}}$ /STOP $\text{\textcircled{M}}$ /FORWARD $\text{\textcircled{L}}$
MIC IN [R]	MIC INPUT (R)	RCH [H]	Rch $\text{\textcircled{H}}$
MIC [H]	MIC $\text{\textcircled{H}}$	REC 12V	RECORDING 12V
MIX [H]	MIX $\text{\textcircled{H}}$	REC CHROMA	RECORDING CHROMINANCE SIGNAL
MIX [H]/CINEMA [L]	MIX $\text{\textcircled{H}}$ /CINEMA SOUND $\text{\textcircled{L}}$	REC H	RECORDING $\text{\textcircled{H}}$
MIX/CINE	MIX $\text{\textcircled{H}}$ /CINEMA SOUND $\text{\textcircled{L}}$	REC IN	RECORDING INPUT
MIX/CINEMA [L]	MIX $\text{\textcircled{H}}$ /CINEMA SOUND $\text{\textcircled{L}}$	REC OUT [L]	RECORDING OUTPUT $\text{\textcircled{L}}$
MN. H/M. L	MONAUROAL $\text{\textcircled{H}}$ /MAIN $\text{\textcircled{L}}$	REC START	RECORDING START
MN. H/MAI. L	MONAUROAL $\text{\textcircled{H}}$ /MAIN $\text{\textcircled{L}}$	REC VR [C]	RECORDING VOLUME (COMMON)
MN2/MES. L	MONAUROAL 2/MESECAM $\text{\textcircled{L}}$	REC VR [L]	RECORDING VOLUME (L)
MODE SEL	AUDIO MODE SELECT	REC VR [R]	RECORDING VOLUME (R)
MODE SW	AUDIO MODE SW	REC Y	RECORDING LUMINANCE SIGNAL
MODE. S. IN	AUDIO MODE SELECT INPUT	REC [H]	RECORDING $\text{\textcircled{H}}$
MODE. S. OUT	AUDIO MODE SELECT OUTPUT	REC. C	RECORDING CHROMINANCE SIGNAL
MONO [H]	MONAUROAL $\text{\textcircled{H}}$	REC. Y	RECORDING LUMINANCE SIGNAL
MONO [H]/MAIN [L]	MONAUROAL $\text{\textcircled{H}}$ /MAIN $\text{\textcircled{L}}$	REC/EE CTL	RECORDING/EE CONTROL
MONO2 [L]	MONAUROAL 2	REEL-T	REEL PULSE (TAKE-UP)
MONO2/MESE [FM(L)]	MONAUROAL 2/MESECAM (FM $\text{\textcircled{L}}$ )	REEL-S	REEL PULSE (SUPPLY)
MOTOR GND	MOTOR GND	REGULATOR FILTER	REGULATOR FILTER
MUTE	MUTE	RESET	RESET
N. A. REC [L]	NORMAL AUDIO RECORDING	REV M F/R	REVIEW MOTOR
N. SW 12V	NON SW 12V		FORWARD/REVERSE
N. SW. 5. DET	NON SW 5V DETECT	REV M V1	REVIEW MOTOR V1
NICAM	NICAM	REV M V2	REVIEW MOTOR V2
NICAM [L]	NICAM $\text{\textcircled{L}}$	REV MOTOR F/R	REVIEW MOTOR
NOL [H]	PAL $\text{\textcircled{H}}$ /4.43 NTSC $\text{\textcircled{M}}$ /3.58 NTSC $\text{\textcircled{L}}$		FORWARD/REVERSE
NOR/SOFT [H]	NORMAL/SOFT TAPE PLAY $\text{\textcircled{H}}$	REV MOTOR V1	REVIEW MOTOR V1
NORMAL [H]	NORMAL $\text{\textcircled{H}}$	REV MOTOR V2	REVIEW MOTOR V2
NR BIAS	NR BIAS	REV MOTOR [+]	REVIEW MOTOR (+)
NTSC [L]	NTSC $\text{\textcircled{L}}$	REV MOTOR [-]	REVIEW MOTOR (-)
OCH	CONTROL AGC CIRCUIT	REV. M. GND	REVIEW MOTOR GND
OUT	OUTPUT	RF. CHROMA	RF CHROMINANCE SIGNAL

RF OUT	RF OUTPUT	SYSCON 5V	SYSTEM CONTROL 5V
RF Y	RF LUMINANCE SIGNAL	SYSTEM SW	SYSTEM SW
RF. Y. IN	RF LUMINANCE SIGNAL INPUT	T-PHOTO	TAKE-UP PHOTO TRANSISTOR
RF. Y. OUT	RF LUMINANCE SIGNAL OUTPUT	T-RL. PLS	TAKE-UP REEL PULSE
ROTAR. SW	ROTARY SW	T. BUSCLK	TIMER BUS CLOCK
ROTARY	ROTARY SW	T. BUSLSN	TIMER BUS LISTEN
RST	RESET	T. BUSTLK	TIMER BUS TALK
RST [L]	RESET (L)	T. END [L]	TAPE END (L)
Rch/INST	Rch/INSERT	T. PHOTO	TAKE-UP PHOTO TRANSISTOR
S IN	SERIAL DATA INPUT	TAPE END [L]	TAPE END (L)
S OUT	SERIAL DATA OUTPUT	TAPE END [L]/CAM	TAPE END (L)/CAMERA PAUSE
S-PHOTO	SUPPLY PHOTO TRANSISTOR	TEST	TEST MODE
S-RL. PLS	SUPPLY REEL PULSE	TPZ	TRAPEZOIDAL WAVE CIRCUIT
S. CLK	SERIAL CLOCK	TRIC [L]	TRIC PLAY (L)
S. CLK/AV	SERIAL CLOCK/AV	TRICK [L]	TRIC PLAY (L)
S. DATA	SERIAL DATA	TRK. ENV	AUTO TRACKING ENVELOPE DETECT
S. DATA/A	SERIAL DATA	TU. AUDIO	TUNER AUDIO
S. PHOTO	SUPPLY PHOTO TRANSISTOR	TU. GND	TUNER GND
S. TAB [L]	SAFETY TAB SW ON (L)	TU. V. IN	TUNER VIDEO SIGNAL INPUT
S/P/N	SECAM/PAL/NTSC	TU. VIDEO	TUNER VIDEO
SC IN	SERIAL CLOCK INPUT	TUN NOR IN	TUNER NORMAL INPUT
SC OUT	SERIAL CLOCK OUTPUT	TUN R	TUNER AUDIO (R)
SCK SELECT	SERIAL CLOCK SELECT	TUN. AUDIO IN	TUNER AUDIO INPUT
SEL OUT [L]	SELECT OUTPUT (L)	TUNER 12V	TUNER 12V
SEL OUT [R]	SELECT OUTPUT (R)	TUNER L	TUNER AUDIO (L)
SHUTTLE 1	SHUTTLE 1	TUNER V IN	TUNER VIDEO SIGNAL INPUT
SIF	SOUND INTERMEDIATE FREQUENCY	TUNER [L]	TUNER AUDIO (L)
SLMUT [H]	INPUT SELECT MUTE (H)	TUNER [N]	TUNER AUDIO (NORMAL)
SLNID [+]	SOLENOID (+)	TUNER [R]	TUNER AUDIO (R)
SLNID [-]	SOLENOID (-)	TUNER. 12	TUNER 12V
SLW TR. MM	SLOW TRACKING MONO MULTI	TUOFF [H]	TUNER OFF (H)
SLW TR. REF	SLOW TRACKING REFERENCE	TV. AUDIO	TV AUDIO
	VOLTAGE	TV/VTR	TV/VTR
SNS. GND	SENSOR GND	TXTON [L]	TEXT ON (L)
SOFT [H]	SOFT TAPE PLAY (H)	U. REG45V	UNREGULATOR 45V
SOFT [H]/NORMAL	SOFT TAPE PLAY (H)/NORMAL (H)	UNREG	UNREGULATOR
SOLENOID ON [L]	SOLENOID ON (L)	UNREG19V	UNREGULATOR 19V
SP [H]	SP (H)	V. REF	REFERENCE VOLTAGE
SP/L/SLP	SP/LP	V. EE [H]	VIDEO EE (H)
SSS [L]	SLOW/STILL/STOP	V. EE [L]	VIDEO EE (L)
STEREO LED	STEREO LED	VCO REF	REFERENCE OSCILLATER
STEREO [H]	STEREO (H)	VD. IN	VIDEO SIGNAL INPUT
STEREO [L]	STEREO (L)	VD. OUT	VIDEO SIGNAL OUTPUT
STOP. PO	STOP POSITION	VIDEO EE [L]	VIDEO EE (L)
STOP/5V	STOP POSITION/5V	VIDEO IN	VIDEO SIGNAL INPUT
STOP1/TAPE SEL	STOP1 POSITION/TAPE SELECT	VIDEO OUT	VIDEO SIGNAL OUTPUT
STOP1/PAL:ST	STOP1 POSITION/PAL	VM	MOTOR VOLTAGE
STOP2. PO	STOP 2 POSITION	VM DOWN [L]	MOTOR VOLTAGE DOWN (L)
STOP2/S-TAB	STOP 2 POSITION/SAFETY TAB SW	VSS	VERTICAL SYNC SIGNAL
STREO [H]	STEREO (H)	VTR [H]	VTR (H)
SUB BIAS	SUB BIAS	VTR. 12V	VTR 12V
SUB. SW	SUB SW	X IN	OSCILLATOR INPUT
SVHS CAS [L]	S-VHS CASSETTE (L)	X OUT	OSCILLATOR OUTPUT
SW. 5. DET	SW 5V DETECT		
SYNC [L]	SYNC (L)		

# 15 Parts and Exploded Views

## 15.1. Exploded Views

### 15.1.1. Casing Parts & Mechanism Section1

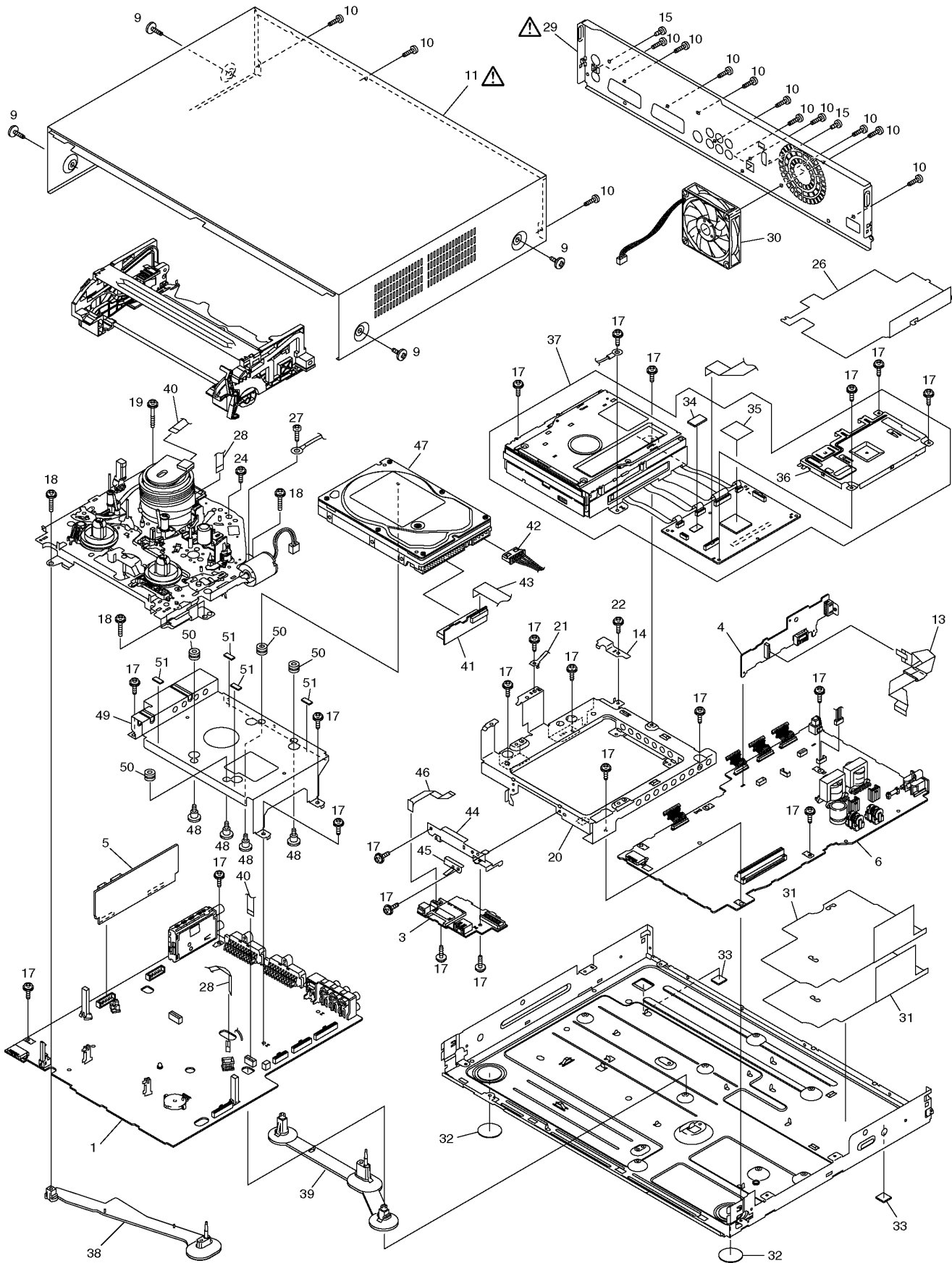

### 15.1.2. Casing Parts & Mechanism Section 2

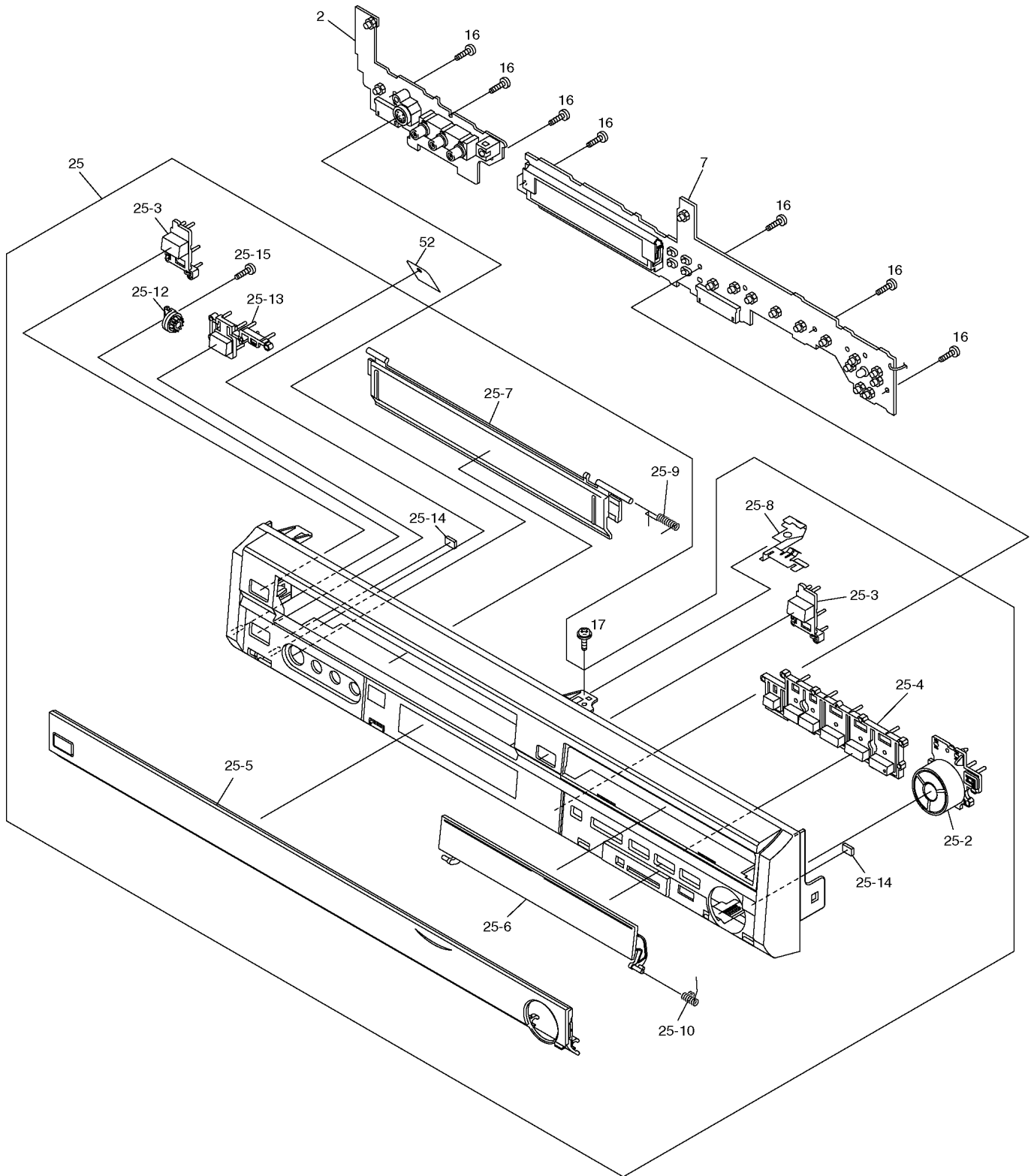

### 15.1.3. VHS Mechanism Section

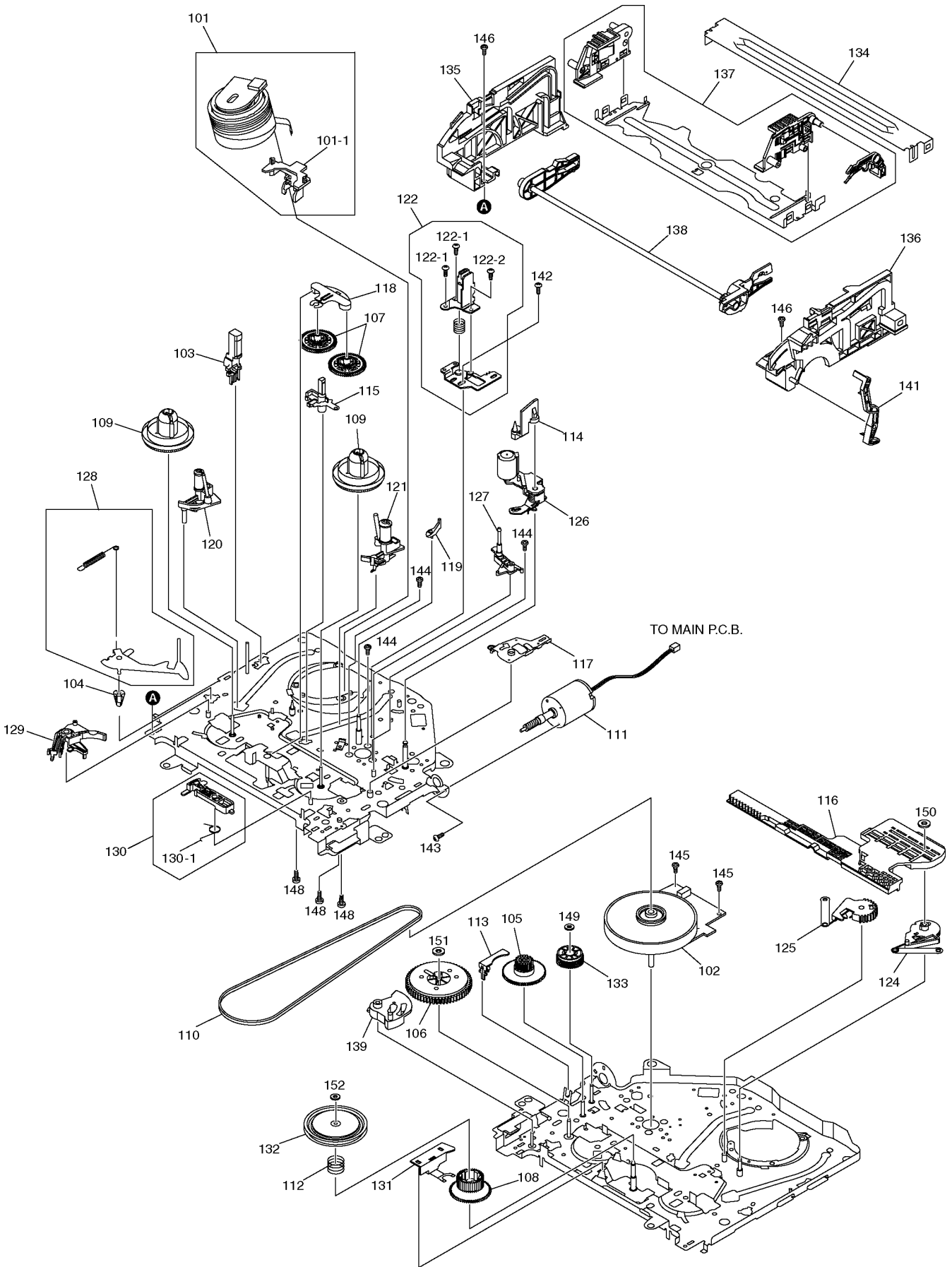

### 15.1.4. Packing & Accessories Section

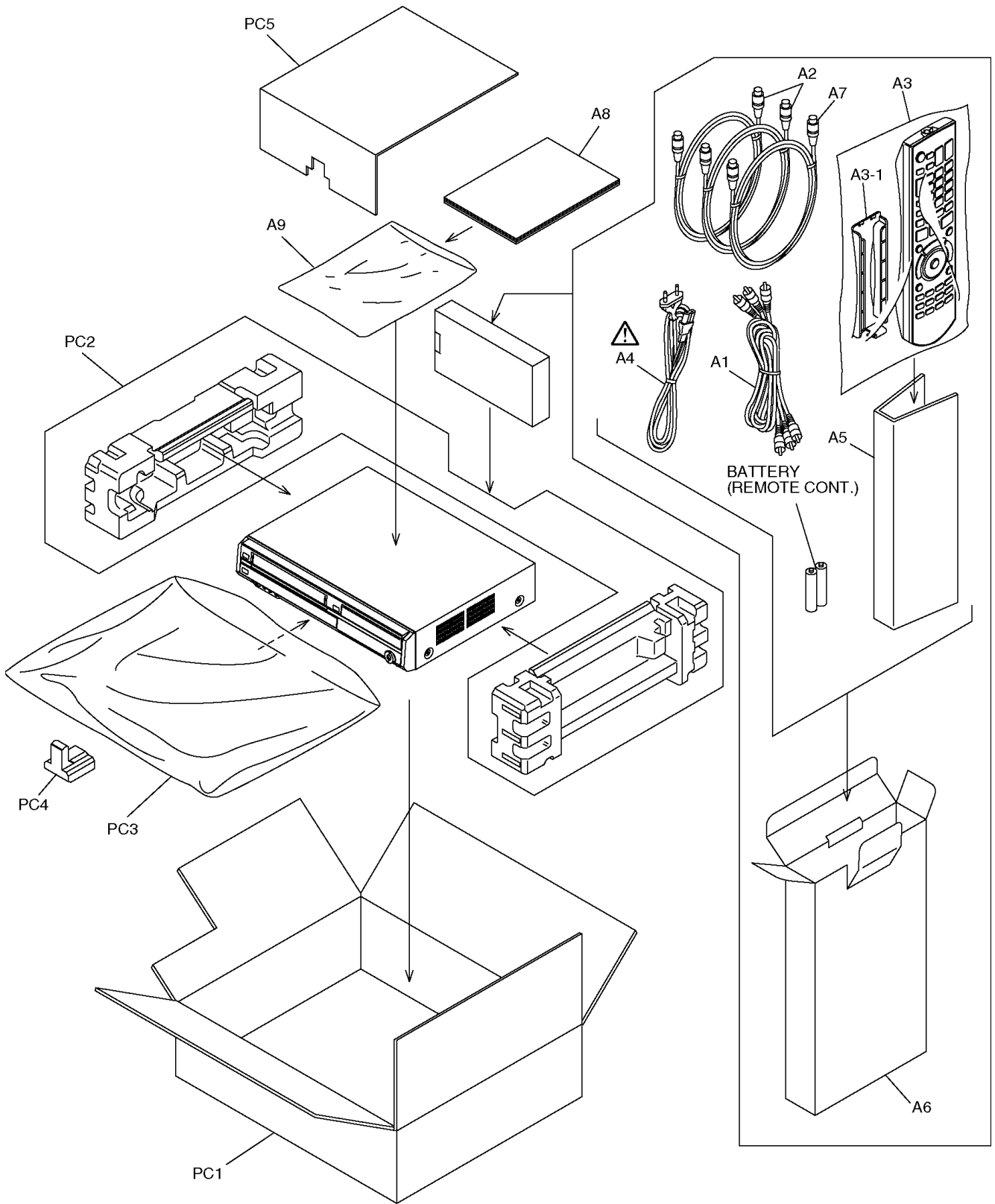

## 15.2. Replacement Parts List

### Notes:

\*Important safety notice:

Components identified by  $\triangle$  mark have special characteristics important for safety.

Furthermore, special parts which have purposes of fire-retardant (resistors), high-quality sound (capacitors), low-noise (resistors), etc. are used.

When replacing any of components, be sure to use only manufactures specified parts shown in the parts list.

\*Warning: This product uses a laser diode. Refer to caution statements.

\*Capacity values are in microfarads ( $\mu\text{F}$ ) unless specified otherwise, P=Pico-farads (pF), F=Farads (F).

\*Resistance values are in ohms, unless specified otherwise, 1K=1,000 (OHM), 1M=1,000k (OHM).

\*The marking (RTL) indicates the retention time is limited for this item. After the discontinuation of this assembly in production, it will no longer be available.

\*“(IA)”-“(IF)”, marks in Remarks indicate languages of instruction manuals. [(IA): English, (IB): German, (IC): French, (ID): English, (IE): Italian, (IF): Spanish]

\*All parts are supplied by PAVCSK.

Ref. No.	Part No.	Part Name & Description	Pcs	Remarks
	VEP79195A	MAIN P.C.B.	1	(RTL) EB
	VEP79195B	MAIN P.C.B.	1	(RTL) EG
	VEP79195C	MAIN P.C.B.	1	(RTL) EC
C2001	F1H1H330A736	50V 33P	1	
C2003	F1H1A1050029	10V 1U	1	
C2051	F1J0J106A014	6.3V 10U	1	
C2052	F1J0J106A014	6.3V 10U	1	
C2053	F2A1C1000021	16V 10U	1	
C2054	ECJ1VB1H392K	50V 3900P	1	
C2055	F1H1C104A008	16V 0.1U	1	
C2099	ECJ1VC1H681J	50V 680P	1	
C2501	F1H1C104A008	16V 0.1U	1	
C2502	F2A0J221A826	6.3V 220U	1	
C2504	F1H1E223A029	25V 0.022U	1	
C2505	F1H1E223A029	25V 0.022U	1	
C2506	F1H1A2240004	10V 0.22U	1	
C2507	F1H1H1020005	50V 0.001U	1	
C2508	F1H1H182A219	50V 1800P	1	
C2509	F2A1C220B100	16V 22U	1	
C2510	F1H1C104A042	16V 0.1U	1	
C2511	F1H1C104A042	16V 0.1U	1	
C2512	F1H1C104A042	16V 0.1U	1	
C2513	F1H1A1050029	10V 1U	1	
C2514	ECJ1VB1A105K	10V 1U	1	
C2515	F1H1H1030006	50V 0.01U	1	
C2518	F1H1H1030006	50V 0.01U	1	
C2519	F1H1H1030006	50V 0.01U	1	
C2551	F1H1C473A071	16V 0.047U	1	
C2552	ECJ1VB1C683K	16V 0.068U	1	
C2561	ECJ1VB1C683K	16V 0.068U	1	
C2562	F1H1C473A071	16V 0.047U	1	
C2571	F2A1C331B103	16V 330P	1	
C3001	F1H1H1510001	50V 150P	1	
C3003	ECJ1VB1A105K	10V 1U	1	
C3004	F1H1C104A042	16V 0.1U	1	
C3005	F1H1H2700003	50V 27P	1	
C3006	F1H1C104A042	16V 0.1U	1	
C3007	ECJ1VB1A105K	10V 1U	1	
C3008	F1H1H1030006	50V 0.01U	1	

Ref. No.	Part No.	Part Name & Description	Pcs	Remarks
C3009	F2A1H4R7B033	50V 4.7U	1	
C3010	ECJ1VB1A105K	10V 1U	1	
C3011	ECJ1VB1A105K	10V 1U	1	
C3012	F2A0J470A824	6.3V 47U	1	
C3013	F1H1H1030006	50V 0.01U	1	
C3015	F1H1C104A042	16V 0.1U	1	
C3016	ECJ1VC1H470J	50V 47P	1	
C3017	ECJ1VB1A105K	10V 1U	1	
C3018	ECJ1VB1A105K	10V 1U	1	
C3019	F2A1C100B099	16V 10U	1	
C3020	ECJ1VC1H331J	50V 330P	1	
C3021	F1H1H1030006	50V 0.01U	1	
C3023	F2A1H3R3B032	50V 3.3U	1	
C3024	F1H1H1030006	50V 0.01U	1	
C3026	ECJ1VB1A105K	10V 1U	1	
C3028	F1H1C104A042	16V 0.1U	1	
C3029	F1H1C104A042	16V 0.1U	1	
C3030	F1H1C104A042	16V 0.1U	1	
C3033	F1H1C104A042	16V 0.1U	1	
C3034	F2A1H1R0B032	50V 1U	1	
C3036	F2A1H4R7B033	50V 4.7U	1	
C3037	F2A1HR47B032	50V 47U	1	
C3038	F1H1E223A029	25V 0.022U	1	
C3039	F1H1C333A041	16V 0.033U	1	
C3040	F2A1H2R2B032	50V 2.2U	1	
C3041	F1H1E223A029	25V 0.022U	1	
C3042	ECJ2YB0J335K	6.3V 3.3U	1	
C3043	F1H1C104A042	16V 0.1U	1	
C3044	F2A0J470A824	6.3V 47U	1	
C3045	F1H1H1030006	50V 0.01U	1	
C3046	ECJ1VC1H030C	50V 3P	1	
C3047	F2A1H1R0B032	50V 1U	1	
C3048	F1H1H1030006	50V 0.01U	1	
C3049	F1H1H1030006	50V 0.01U	1	
C3050	F1H1A1050029	10V 1U	1	
C3051	ECJ1VB1A105K	10V 1U	1	
C3052	ECJ1VB1A105K	10V 1U	1	
C3053	F1H1C104A042	16V 0.1U	1	
C3904	F1H1H1030006	50V 0.01U	1	
C3905	ECJ1VB1A105K	10V 1U	1	
C3906	F1H1C104A042	16V 0.1U	1	
C3907	ECJ1VB1A105K	10V 1U	1	
C3908	F1H1C104A042	16V 0.1U	1	
C3909	ECJ1VB1A105K	10V 1U	1	
C3910	ECJ1VB1A105K	10V 1U	1	
C3911	F1H1H1030006	50V 0.01U	1	
C3912	F2A0J101A167	6.3V 100U	1	
C3913	F1H1C104A042	16V 0.1U	1	
C3914	F1H1H1030006	50V 0.01U	1	
C3915	F1H1C104A042	16V 0.1U	1	
C3916	F1H1C104A042	16V 0.1U	1	
C3917	F2A1A471A869	10V 470U	1	
C3918	F2A1A101A868	10V 100U	1	
C3919	F1H1C104A042	16V 0.1U	1	
C3920	F1H1H1030006	50V 0.01U	1	
C3921	F1H1C104A042	16V 0.1U	1	
C3922	F1H1H1030006	50V 0.01U	1	
C3923	F1H1H1030006	50V 0.01U	1	
C3924	F1H1C104A042	16V 0.1U	1	
C3925	F1H1C104A042	16V 0.1U	1	
C3926	F1H1C104A042	16V 0.1U	1	
C3927	F1H1C104A042	16V 0.1U	1	
C3928	F1H1H1030006	50V 0.01U	1	
C3929	F2A0J101A167	6.3V 100U	1	
C3934	F1H1C104A042	16V 0.1U	1	
C3936	F2A0J471A832	6.3V 470U	1	
C3937	F2A0J471A832	6.3V 470U	1	
C3938	F2A1A471A869	10V 470U	1	
C3939	F2A1A101A868	10V 100U	1	
C3940	F1H1H330A736	50V 33P	1	
C3946	F1H1C104A042	16V 0.1U	1	

Ref. No.	Part No.	Part Name & Description	Pcs	Remarks
C3947	F1H1C104A042	16V 0.1U	1	
C3948	F1H1C104A042	16V 0.1U	1	
C3949	F2A1A471A869	10V 470U	1	
C3950	F2A1A101A868	10V 100U	1	
C3955	F1H1H1030006	50V 0.01U	1	
C3956	F1H1H1030006	50V 0.01U	1	
C4001	F2A1C100A234	16V 10U	1	
C4002	F2A1C100A234	16V 10U	1	
C4004	F2A1C100A234	16V 10U	1	
C4008	F1H1H182A219	50V 1800P	1	
C4009	F2A0J220A245	6.3V 22U	1	
C4010	F2A1H4R7A234	50V 4.7U	1	
C4011	F2A0J470A245	6.3V 47U	1	
C4012	F1H1H1030006	50V 0.01U	1	
C4014	F2A1H4R7A234	50V 4.7U	1	
C4015	F1H1H682A219	50V 6800P	1	
C4016	F2A0J220A245	6.3V 22U	1	
C4017	F2A1H3R3A234	50V 3.3U	1	
C4018	F1H1H182A219	50V 1800P	1	
C4020	ECQB1H333JF3	50V 0.033U	1	
C4021	ECJ1VB1H471K	50V 470P	1	
C4022	F2A0J101A245	6.3V 100U	1	
C4023	F1H1E223A029	25V 0.022U	1	
C4024	F1H1H182A219	50V 1800P	1	
C4025	ECJ2VF1H103Z	50V 0.01U	1	
C4101	ECJ1VB1H471K	50V 470P	1	
C4102	ECJ1VB1H471K	50V 470P	1	
C4103	ECJ1VC1H470J	50V 47P	1	
C4104	ECJ1VC1H470J	50V 47P	1	
C4105	F1H1H1010005	50V 100P	1	
C4106	F1H1H1010005	50V 100P	1	
C4107	ECJ1VB1H471K	50V 470P	1	
C4108	ECJ1VB1H471K	50V 470P	1	
C4109	ECJ1VC1H470J	50V 47P	1	
C4110	ECJ1VC1H470J	50V 47P	1	
C4111	F1H1H1010005	50V 100P	1	
C4112	F1H1H1010005	50V 100P	1	
C4501	F2A1C100A234	16V 10U	1	
C4502	F2A1C100A234	16V 10U	1	
C4503	F2A1C100A234	16V 10U	1	
C4504	ECQB1H473JF3	50V 0.047U	1	
C4505	F2A0J330A245	6.3V 33U	1	
C4506	F2A1C100A234	16V 10U	1	
C4508	F2A1C100A234	16V 10U	1	
C4509	F2A0J220A245	6.3V 22U	1	
C4510	ECQB1H153JF3	50V 0.015U	1	
C4511	F1H1C333A041	16V 0.033U	1	
C4512	F1H1H1030006	50V 0.01U	1	
C4513	F1H1H1030006	50V 0.01U	1	
C4515	F1H1E104A030	25V 0.1U	1	
C4516	F1H1C104A042	16V 0.1U	1	
C4518	F1H1A2240004	10V 0.22U	1	
C4519	ECQB1H153JF3	50V 0.015U	1	
C4520	F2A1C220A234	16V 22U	1	
C4521	F2A1C100A234	16V 10U	1	
C4522	F2A0J330A245	6.3V 33U	1	
C4523	ECQB1H473JF3	50V 0.047U	1	
C4524	F2A0J101A245	6.3V 100U	1	
C4526	F2A1C100A234	16V 10U	1	
C4531	F2A1C470A234	16V 47U	1	
C4533	F1H1H1030006	50V 0.01U	1	
C4534	F1H1C104A042	16V 0.1U	1	
C4544	F1H1E104A030	25V 0.1U	1	
C4545	F2A1C220A234	16V 22U	1	
C4546	F2A1C100A234	16V 10U	1	
C4547	F2A1C100A234	16V 10U	1	
C4548	F1H1H1020005	50V 0.001U	1	
C4901	F2A1C471A628	16V 470U	1	
C4917	F2A1H100A236	50V 10U	1	
C4918	F2A1H100A236	50V 10U	1	
C4922	F2A1H100A236	50V 10U	1	
C4923	F2A1H100A236	50V 10U	1	
C4924	F2A1V100A534	35V 10U	1	

Ref. No.	Part No.	Part Name & Description	Pcs	Remarks
C4925	F2A1V100A534	35V 10U	1	
C4926	ECJ1VB1A105K	10V 1U	1	
C4927	F2A1E1010067	25V 100U	1	
C4928	F2A1V100A534	35V 10U	1	
C4929	F2A1H1R0A236	50V 1U	1	
C4930	F2A1H1R0A236	50V 1U	1	EG, EC
C4931	F2A1H1R0A236	50V 1U	1	
C4932	F2A1H100A236	50V 10U	1	
C4933	F2A1V100A534	35V 10U	1	
C4934	F2A1V100A534	35V 10U	1	
C4935	F2A1E1010067	25V 100U	1	
C4936	F2A1V100A534	35V 10U	1	
C4937	F2A1H1R0A236	50V 1U	1	
C4938	F2A1H1R0A236	50V 1U	1	EG, EC
C4939	F2A1H1R0A236	50V 1U	1	
C4940	F2A1H100A236	50V 10U	1	
C4941	F2A1V100A534	35V 10U	1	
C4943	F2A1V100A534	35V 10U	1	
C4944	F2A1E2210050	25V 220U	1	
C4945	F2A1E2210050	25V 220U	1	
C4946	F1H1H1020005	50V 0.001U	1	
C4947	F1H1H1020005	50V 0.001U	1	
C4950	F1J1H102A666	50V 100P	1	
C4951	F1J1H102A666	50V 100P	1	
C4965	ECJ1VC1H471J	50V 470P	1	
C4967	ECJ1VC1H471J	50V 470P	1	
C5001	F1H1H1030006	50V 0.01U	1	
C5002	F1H1H1030006	50V 0.01U	1	
C5003	F1H1H1030006	50V 0.01U	1	
C5004	F1H1H1030006	50V 0.01U	1	
C5005	F1H1E104A030	25V 0.1U	1	
C5006	F2A0J470A245	6.3V 47U	1	
C5007	F1H1C104A042	16V 0.1U	1	
C6001	ECJ1VC1H180J	50V 18P	1	
C6002	ECJ1VC1H220J	50V 22P	1	
C6003	F1H1H1030006	50V 0.01U	1	
C6004	F1H1H1030006	50V 0.01U	1	
C6005	F2A1C100B099	16V 10U	1	
C6007	ECJ1VC1H220J	50V 22P	1	
C6008	ECJ1VC1H471J	50V 470P	1	
C6009	F1H1H1030006	50V 0.01U	1	
C6010	ECJ1VC1H220J	50V 22P	1	
C6014	F1H1H1030006	50V 0.01U	1	
C6015	F1H1C333A041	16V 0.033U	1	
C6016	F1H1H1020005	50V 0.001U	1	
C6017	F1H1C104A042	16V 0.1U	1	
C6018	F1H1C104A042	16V 0.1U	1	
C6020	ECJ2VF1H104Z	50V 0.1U	1	
C6022	F2A0J221A826	6.3V 220U	1	
C6101	F2A0J221A826	6.3V 220U	1	
C6103	F1H1A1050029	10V 1U	1	
C6110	F1H1A1050029	10V 1U	1	
C6111	ECJ1VB1H561K	50V 560P	1	
C6115	F1H1H1030006	50V 0.01U	1	
C6116	F1H1C104A042	16V 0.1U	1	
C6121	F1H1H330A736	50V 33P	1	
C6301	F1H1E104A030	25V 0.1U	1	
C6302	F1H1H1030006	50V 0.01U	1	
C6303	F2A1A470A863	10V 47P	1	
C6308	F2A0J470A824	6.3V 47U	1	
C7301	F2A1C100A234	16V 10U	1	EG, EC
C7303	F1H1H472A219	50V 4700P	1	EG, EC
C7304	F1H1H472A219	50V 4700P	1	EG, EC
C7305	F1H1C104A042	16V 0.1U	1	EG, EC
C7306	F1H1C104A042	16V 0.1U	1	EG, EC
C7307	F1H1C104A042	16V 0.1U	1	EG, EC
C7308	F1H1C104A042	16V 0.1U	1	EG, EC
C7309	F1H1C104A042	16V 0.1U	1	EG, EC
C7310	F1H1C104A042	16V 0.1U	1	EG, EC
C7313	F2A0J470A824	6.3V 47U	1	EG, EC
C7314	F2A0J470A824	6.3V 47U	1	EG, EC
C7315	F2A0J470A824	6.3V 47U	1	EG, EC
C7316	F1H1H472A219	50V 4700P	1	EG, EC

Ref. No.	Part No.	Part Name & Description	Pcs	Remarks
C7317	F1H1C104A042	16V 0.1U	1	EG, EC
C7318	F1H1C104A042	16V 0.1U	1	EG, EC
C7319	F1H1C104A042	16V 0.1U	1	EG, EC
C7320	F1H1C104A042	16V 0.1U	1	EG, EC
C7321	F1H1C104A042	16V 0.1U	1	EG, EC
C7322	F1H1C104A042	16V 0.1U	1	EG, EC
C7323	F1H1C104A042	16V 0.1U	1	EG, EC
C7324	F1H1C104A042	16V 0.1U	1	EG, EC
C7325	ECJ1VC1H331J	50V 330P	1	EG, EC
C7326	F2A0J470A824	6.3V 47U	1	EG, EC
C7327	ECJ1VC1H100D	50V 10P	1	EG, EC
C7328	ECJ1VC1H100D	50V 10P	1	EG, EC
C7329	F1H1C104A042	16V 0.1U	1	EG, EC
C7330	F1H1C104A042	16V 0.1U	1	EG, EC
C7331	F1H1H2700003	50V 27P	1	EG, EC
C7332	F1H1H2700003	50V 27P	1	EG, EC
C7333	F1H1C104A042	16V 0.1U	1	EG, EC
C7336	F1H0J1050012	6.3V 1U	1	EG, EC
C7337	F1H0J1050012	6.3V 1U	1	EG, EC
C7338	F1H0J1050012	6.3V 1U	1	EG, EC
C7339	F1H0J1050012	6.3V 1U	1	EG, EC
C7403	ECJ1VB1A105K	10V 1U	1	
C7404	ECJ1VB1A105K	10V 1U	1	
C7406	ECJ1VB1A105K	10V 1U	1	
C7407	ECJ1VB1A105K	10V 1U	1	
C7410	F1J0J106A014	6.3V 10U	1	
C7411	ECJ1VB1A105K	10V 1U	1	
C7439	F1H1C104A042	16V 0.1U	1	
C7801	F2A0J470A824	6.3V 47U	1	
C7803	F2A1H1R0B032	50V 1U	1	
C7804	F1H1H1030006	50V 0.01U	1	
C7807	ECJ1VC1H100D	50V 10P	1	EB
C7808	ECJ1VC1H100D	50V 10P	1	EB
C7809	F2A0J470A824	6.3V 47U	1	EG, EC
C7810	F1H1H1030006	50V 0.01U	1	EG, EC
C7811	F2A0J470A824	6.3V 47U	1	
C7812	F1H1H1030006	50V 0.01U	1	
C7813	F1H1H222A219	50V 2200P	1	EG, EC
C7814	ECJ1VC1H390J	50V 39P	1	EB
C7815	ECJ1VC1H390J	50V 39P	1	EB
C7815	ECJ1VC1H680J	50V 68P	1	EG, EC
C7816	F1H1C104A042	16V 0.1U	1	
C7817	F1H1C104A042	16V 0.1U	1	EG
C7818	F1H1C104A042	16V 0.1U	1	EG
C7819	F2A0J470A824	6.3V 47U	1	EG
C7820	F1H1H222A219	50V 2200P	1	
C7821	F1H1H1030006	50V 0.01U	1	EG, EC
C7821	F1H1H2710007	50V 270P	1	EB
C7822	ECJ2VC1H681J	50V 680P	1	EG, EC
C7823	ECJ2VC1H220J	50V 22P	1	
C7824	ECJ1VC1H220J	50V 22P	1	
C7826	F1H1H222A219	50V 2200P	1	EB
C7827	ECJ1VC1H221J	50V 220P	1	
C7830	ECJ1VC1H680J	50V 68P	1	EG, EC
C7841	F1H1H1010005	50V 100P	1	EG, EC
C7842	F1H1H1030006	50V 0.01U	1	EG, EC
D2001	B0AACK000004	DIODE	1	
D2002	B0AACK000004	DIODE	1	
D2502	MAZ4160NMF	DIODE	1	
D3901	B0AACK000004	DIODE	1	
D4501	B0AACK000004	DIODE	1	
D4502	MAZ4056NHF	DIODE	1	
D4950	MA3Z142D0LG	DIODE	1	
D6306	MAZ4056NHF	DIODE	1	
D6501	B3EA00000072	LED	1	
D7303	MA22D3900L	DIODE	1	EG, EC
D7304	MA22D3900L	DIODE	1	EG, EC
D7801	B0BA03000015	DIODE	1	
D7802	MA2C72300F	DIODE	1	EG
D7803	MAZ4051NMF	DIODE	1	EG
IC2501	C1AB00001767	IC	1	

Ref. No.	Part No.	Part Name & Description	Pcs	Remarks
IC3001	C1AB00002084	IC	1	
IC3002	C0CBCDD00026	IC	1	
IC3901	C1AB00002379	IC	1	
IC3905	C1AB00001340	IC	1	
IC4501	AN3656NFBPBV	IC	1	
IC6001	C2CBHF000476	IC	1	
IC6302	C0CBCDC00020	IC	1	
IC6501	B3NAA0000118	IC	1	
IC6502	B3NAA0000118	IC	1	
IC7301	C1AB00002844	IC	1	EC
IC7301	C1AB00002845	IC	1	EG
IC7302	C0EBE0000366	IC	1	EG, EC
IC7303	C0CBCBC00174	IC	1	EG, EC
IC7304	C0CBCAC00242	IC	1	EG, EC
IC7401	C0CBCDC00052	IC	1	
IC7402	C0CBCDC00052	IC	1	
IC7403	C0DBEHE00005	IC	1	
IC7404	C0CBYCG00004	IC	1	
IC7801	C0DBGYY00033	IC	1	EG
JK3901	K1FB121B0018	CONNECTOR	1	
JK3902	K1FB121B0018	CONNECTOR	1	
JK4901	K1U717B00005	JACK	1	
K2597	DOYBR0000020	1/10W 0	1	
K3904	DOYBR0000020	1/10W 0	1	EB
K4001	DOYBR0000020	1/10W 0	1	
K7302	DOYBR0000020	1/10W 0	1	EG, EC
K7306	ERJ6GEY0R00Z	1/8W 0	1	EG, EC
K7307	ERJ6GEY0R00Z	1/8W 0	1	EG, EC
K7401	J0JDC0000092	COIL	1	
K7809	DOYBR0000020	1/10W 0	1	EG
L3001	G0C820JA0019	COIL	1	
L3002	G0C270JA0019	COIL 27UH	1	
L3003	G0C390JA0019	COIL	1	
L3004	G0C680JA0019	COIL 68UH	1	
L3006	G0C270JA0019	COIL 27UH	1	
L3007	ELJFA120KFB	COIL	1	
L4001	G0C221KA0073	COIL 220UH	1	
L4502	G0C1R2J00004	COIL 1.2UH	1	
L4503	G0C101JA0019	COIL 100UH	1	
L5001	G0C680JA0019	COIL 68UH	1	
L6103	G0C1R5JA0019	COIL 1.5UH	1	
L6105	G0C680JA0019	COIL 68UH	1	
L7301	G0C2R2JA0019	COIL 2.2UH	1	EG, EC
L7801	G0C100JA0019	COIL 10UH	1	EG
L7802	G1CR56JA0020	COIL 56UH	1	
L7803	G1CR56JA0020	COIL 56UH	1	
LB3901	J0JGC0000020	COIL	1	
LB3964	DOYBR0000020	1/10W 0	1	
LB3965	DOYBR0000020	1/10W 0	1	
LB3966	DOYBR0000020	1/10W 0	1	
LB4002	J0JBC0000070	COIL	1	
LB4003	J0JBC0000070	COIL	1	
LB4101	J0JBC0000041	COIL	1	
LB4102	J0JHC0000021	COIL	1	
LB4103	J0JBC0000011	COIL	1	
LB4104	J0JBC0000011	COIL	1	
LB4105	J0JBC0000011	COIL	1	
LB4106	J0JBC0000011	COIL	1	
LB4203	DOYBR0000020	1/10W 0	1	
LB4901	J0JGC0000020	COIL	1	
LB4902	J0JDC0000092	COIL	1	
LB4903	DOYBR0000020	1/10W 0	1	EG, EC
LB4904	J0JDC0000092	COIL	1	
LB4905	DOYBR0000020	1/10W 0	1	EG, EC
LB4906	DOYBR0000020	1/10W 0	1	
LB4907	DOYBR0000020	1/10W 0	1	
LB4963	J0JCC0000103	COIL	1	
LB4965	J0JCC0000103	COIL	1	
LB6002	J0JHC0000032	COIL	1	

Ref. No.	Part No.	Part Name & Description	Pcs	Remarks
LB7301	ERJ6GEY0R00Z	1/8W 0	1	EG, EC
LB7302	J0JCC0000124	COIL	1	EG, EC
LB7303	J0JCC0000080	COIL	1	EG, EC
LB7304	J0JCC0000124	COIL	1	EG, EC
LB7305	J0JCC0000080	COIL	1	EG, EC
LB7306	J0JCC0000124	COIL	1	EG, EC
LB7401	J0JHC0000032	COIL	1	
LB7402	J0JHC0000032	COIL	1	
LB7801	J0JHC0000032	COIL	1	
LB7802	J0JHC0000032	COIL	1	EG, EC
LB7803	J0JHC0000032	COIL	1	
LB7804	J0JCC0000103	COIL	1	EG, EC
LB7805	J0JCC0000103	COIL	1	
P2501	K1MN07A00030	CONNECTOR (7P)	1	
P2571	K1KA08A00359	CONNECTOR (8P)	1	
P3001	K1MN09A00029	CONNECTOR (9P)	1	
P4001	K1KB02A00035	CONNECTOR (2P)	1	
P4002	K1MN06A00042	CONNECTOR (6P)	1	
P6001	K1KB19AA0032	CONNECTOR (19P)	1	
P6002	K1KB19AA0032	CONNECTOR (19P)	1	
P6003	K1KB23A00004	CONNECTOR (23P)	1	
P6004	K1KB13AA0032	CONNECTOR (13P)	1	
P6531	K1KA02A00375	CONNECTOR (2P)	1	
P7401	K1KA11AA0031	CONNECTOR (11P)	1	
P7402	K1KA10AA0031	CONNECTOR (10P)	1	
PS6002	K1KB12B00047	CONNECTOR (12P)	1	
Q3002	2SD1819A0L	TRANSISTOR	1	
Q4001	2SD114900L	TRANSISTOR	1	
Q4002	2SD1819A0L	TRANSISTOR	1	
Q4003	2SD0602ARL	TRANSISTOR	1	
Q4004	2SB0710A0L	TRANSISTOR	1	
Q4501	B1AAGD000016	TRANSISTOR	1	
Q4502	2SB0710A0L	TRANSISTOR	1	
Q4950	2SD132800L	TRANSISTOR	1	
Q4951	2SD132800L	TRANSISTOR	1	
Q6102	2SD1819A0L	TRANSISTOR	1	
Q6103	2SD1819A0L	TRANSISTOR	1	
Q6104	2SB1218A0L	TRANSISTOR	1	
Q6305	2SD0601A0L	TRANSISTOR	1	
Q6501	PNB2303M01VT	TRANSISTOR	1	
Q6502	PNB2303M01VT	TRANSISTOR	1	
Q7802	2SD1819A0L	TRANSISTOR	1	EG
Q7803	2SD1819A0L	TRANSISTOR	1	EG
QR4004	UNR5111J0L	TRANSISTOR	1	
QR4005	UNR5213J0L	TRANSISTOR	1	
QR4501	UNR5211J0L	TRANSISTOR	1	
QR4911	UNR5113J0L	TRANSISTOR	1	
QR4912	UNR5216J0L	TRANSISTOR	1	
QR4913	UNR5216J0L	TRANSISTOR	1	
QR4915	UNR5211J0L	TRANSISTOR	1	
QR7403	UNR5213J0L	TRANSISTOR	1	
QR7404	UNR5112J0L	TRANSISTOR	1	
R2001	D0GB392JA057	1/10W 3.9K	1	
R2002	D0GB105JA057	1/10W 1M	1	
R2099	D0GB682JA057	1/10W 6.8K	1	
R2501	ERJ6GEYJ1R2V	1/8W 1.2	1	
R2502	ERJ6GEYJ1R5V	1/8W 1.5	1	
R2503	ERDS2TJ103T	1/4W 10K	1	
R2514	D0GB221JA057	1/10W 220	1	
R2515	D0GB221JA057	1/10W 220	1	
R2516	D0GB221JA057	1/10W 220	1	
R2520	D0GB183JA057	1/10W 18K	1	
R2521	D0GB102JA057	1/10W 1K	1	
R2551	D0GB103JA057	1/10W 10K	1	
R2552	D0GB103JA057	1/10W 10K	1	
R2561	D0GB102JA057	1/10W 1K	1	
R2562	D0GB473JA057	1/10W 47K	1	
R2563	D0GB102JA057	1/10W 1K	1	

Ref. No.	Part No.	Part Name & Description	Pcs	Remarks
R2564	D0GB101JA057	1/10W 100	1	
R2565	D0GB101JA057	1/10W 100	1	
R3001	D0GB152JA057	1/10W 1.5K	1	
R3002	D0GB622JA057	1/10W 6.2K	1	
R3003	D0GB562JA057	1/10W 5.6K	1	
R3005	D0GB122JA057	1/10W 1.2K	1	
R3008	D0GB106JA057	1/10W 10M	1	
R3010	D0GB153JA057	1/10W 15K	1	
R3013	D0GB101JA057	1/10W 100	1	
R3014	D0GB101JA057	1/10W 100	1	
R3015	D0GB273JA057	1/10W 27K	1	
R3016	D0GB471JA057	1/10W 470	1	
R3017	D0GB332JA057	1/10W 3.3K	1	
R3021	D0GB102JA057	1/10W 1K	1	
R3901	D0GB750JA057	1/10W 75	1	
R3902	D0GB750JA057	1/10W 75	1	
R3903	D1BB75R0A010	2W 75	1	
R3904	D1BB75R0A010	2W 75	1	
R3905	D1BB75R0A010	2W 75	1	
R3906	D0GB750JA057	1/10W 75	1	
R3907	ERDS2TJ221T	1/4W 220	1	
R3908	D0GB750JA057	1/10W 75	1	
R3909	D0GB750JA057	1/10W 75	1	
R3910	D1BB75R0A010	2W 75	1	
R3911	D1BB75R0A010	2W 75	1	
R3912	D1BB75R0A010	2W 75	1	
R3913	D0GB750JA057	1/10W 75	1	
R3914	D0GB330JA057	1/10W 33	1	
R3915	D0YBR0000020	1/10W 0	1	
R3916	D0GB101JA057	1/10W 100	1	
R3917	D0GB101JA057	1/10W 100	1	
R3918	D0YBR0000020	1/10W 0	1	
R3921	D0GB682JA057	1/10W 6.8K	1	
R3931	D0GB104JA057	1/10W 100K	1	
R3941	D1BB75R0A010	2W 75	1	
R3942	D1BB75R0A010	2W 75	1	
R3943	D1BB75R0A010	2W 75	1	
R3965	D0GB750JA057	1/10W 75	1	
R3966	D0GB750JA057	1/10W 75	1	
R3967	D0GB750JA057	1/10W 75	1	
R4001	D0GB183JA057	1/10W 18K	1	EG, EC
R4002	D0GB153JA057	1/10W 15K	1	
R4003	D0GB333JA057	1/10W 33K	1	EG, EC
R4004	D0GB472JA057	1/10W 4.7K	1	
R4008	D0GB153JA057	1/10W 15K	1	
R4009	D0GB271JA057	1/10W 2.7K	1	
R4011	D0GB183JA057	1/10W 18K	1	
R4012	D0GB474JA057	1/10W 470K	1	
R4013	D0GB153JA057	1/10W 15K	1	
R4014	D0GB103JA057	1/10W 10K	1	
R4015	D0GB332JA057	1/10W 3.3K	1	
R4016	D0GB222JA057	1/10W 2.2K	1	
R4017	D0GB222JA057	1/10W 2.2K	1	
R4018	ERJ6GEYJ102V	1/8W 1K	1	
R4019	ERJ6GEYJ102V	1/8W 1K	1	
R4101	D0GB102JA057	1/10W 1K	1	
R4102	D0GB102JA057	1/10W 1K	1	
R4103	D0GB102JA057	1/10W 1K	1	
R4104	D0GB102JA057	1/10W 1K	1	
R4508	D0GB912JA057	1/10W 9.1K	1	
R4509	D0GB472JA057	1/10W 4.7K	1	
R4511	D0GB912JA057	1/10W 9.1K	1	
R4512	D0GB472JA057	1/10W 4.7K	1	
R4513	D0GB563JA057	1/10W 56K	1	
R4514	D0GB563JA057	1/10W 56K	1	
R4515	D0GB683JA057	1/10W 68K	1	
R4516	D0GB683JA057	1/10W 68K	1	
R4517	D0GB511JA057	1/10W 510	1	
R4518	D0GB472JA057	1/10W 4.7K	1	
R4519	D0GB472JA057	1/10W 4.7K	1	
R4520	D0GB821JA057	1/10W 820	1	
R4521	D0GB124JA057	1/10W 120K	1	
R4522	D0GB472JA057	1/10W 4.7K	1	

Ref. No.	Part No.	Part Name & Description	Pcs	Remarks
R4523	DOGB511JA057	1/10W 510	1	
R4524	DOGB102JA057	1/10W 1K	1	
R4525	DOGB333JA057	1/10W 33K	1	
R4526	DOGB102JA057	1/10W 1K	1	
R4527	DOGB102JA057	1/10W 1K	1	
R4528	DOGB472JA057	1/10W 4.7K	1	
R4532	DOGB681JA057	1/10W 680	1	
R4555	ERDS2TJ821T	1/4W 820	1	
R4559	DOGB393JA057	1/10W 39K	1	
R4560	DOGB682JA057	1/10W 6.8K	1	
R4901	DOGB473JA057	1/10W 47K	1	
R4902	DOGB473JA057	1/10W 47K	1	
R4904	DOGB223JA057	1/10W 22K	1	
R4908	DOGB471JA057	1/10W 470	1	
R4909	DOGB471JA057	1/10W 470	1	
R4910	DOGB471JA057	1/10W 470	1	
R4911	DOGB471JA057	1/10W 470	1	
R4914	DOGB473JA057	1/10W 47K	1	
R4915	DOGB473JA057	1/10W 47K	1	
R4916	DOGB103JA057	1/10W 10K	1	
R4917	DOGB103JA057	1/10W 10K	1	
R4918	DOGB103JA057	1/10W 10K	1	
R4919	DOGB103JA057	1/10W 10K	1	
R4922	DOGB471JA057	1/10W 470	1	
R4927	DOGB471JA057	1/10W 470	1	
R4930	DOGB473JA057	1/10W 47K	1	EG, EC
R4931	DOGB473JA057	1/10W 47K	1	EG, EC
R4932	DOGB823JA057	1/10W 82K	1	
R4933	DOGB102JA057	1/10W 1K	1	
R4934	DOGB823JA057	1/10W 82K	1	
R4935	DOGB102JA057	1/10W 1K	1	
R4950	DOGB101JA057	1/10W 100	1	
R4951	DOGB272JA057	1/10W 2.7K	1	
R4952	DOGB101JA057	1/10W 100	1	
R4953	DOGB272JA057	1/10W 2.7K	1	
R6001	DOGB102JA057	1/10W 1K	1	
R6002	DOGB102JA057	1/10W 1K	1	
R6003	DOGB101JA057	1/10W 100	1	
R6004	DOGB101JA057	1/10W 100	1	
R6005	DOGB102JA057	1/10W 1K	1	
R6006	DOGB273JA057	1/10W 27K	1	
R6007	DOGB822JA057	1/10W 8.2K	1	
R6008	DOGB222JA057	1/10W 2.2K	1	
R6011	DOGB822JA057	1/10W 8.2K	1	
R6012	DOGB681JA057	1/10W 680	1	
R6013	DOGB221JA057	1/10W 220	1	
R6014	DOGB103JA057	1/10W 10K	1	
R6016	DOGB102JA057	1/10W 1K	1	
R6017	DOGB222JA057	1/10W 2.2K	1	
R6018	DOGB102JA057	1/10W 1K	1	
R6019	DOGB681JA057	1/10W 680	1	
R6022	DOGB221JA057	1/10W 220	1	
R6023	DOGB221JA057	1/10W 220	1	
R6024	DOGB102JA057	1/10W 1K	1	
R6025	DOGB221JA057	1/10W 220	1	
R6026	DOGB103JA057	1/10W 10K	1	
R6027	DOGB103JA057	1/10W 10K	1	
R6028	DOGB103JA057	1/10W 10K	1	
R6029	DOGB472JA057	1/10W 4.7K	1	
R6030	DOGB472JA057	1/10W 4.7K	1	
R6031	DOGB223JA057	1/10W 22K	1	
R6101	DOGB105JA057	1/10W 1M	1	
R6115	DOGB471JA057	1/10W 470	1	
R6117	DOGB181JA057	1/10W 180	1	
R6120	DOGB102JA057	1/10W 1K	1	
R6121	DOGB561JA057	1/10W 560	1	
R6122	DOGB561JA057	1/10W 560	1	
R6123	DOGB241JA057	1/10W 270	1	
R6131	DOYBR0000020	1/10W 0	1	
R6201	DOGB103JA057	1/10W 10K	1	
R6309	DOGB272JA057	1/10W 2.7K	1	
R6501	DOGB273JA057	1/10W 27K	1	
R6502	DOGB273JA057	1/10W 27K	1	

Ref. No.	Part No.	Part Name & Description	Pcs	Remarks
R6503	ERDS2TJ151T	1/4W 150	1	
R6511	DOGB273JA057	1/10W 27K	1	
R6512	DOGB273JA057	1/10W 27K	1	
R6513	ERJ6GEYJ121V	1/8W 120	1	
R7301	DOGB102JA057	1/10W 1K	1	EG, EC
R7302	DOGB102JA057	1/10W 1K	1	EG, EC
R7303	DOGB102JA057	1/10W 1K	1	EG, EC
R7304	DOGB103JA057	1/10W 10K	1	EG, EC
R7305	DOGB102JA057	1/10W 1K	1	EG, EC
R7306	DOGB103JA057	1/10W 10K	1	EG, EC
R7307	DOGB101JA057	1/10W 100	1	EG, EC
R7308	DOGB101JA057	1/10W 100	1	EG, EC
R7309	DOGB105JA057	1/10W 1M	1	EG, EC
R7310	DOGB222JA057	1/10W 2.2K	1	EG, EC
R7311	DOGB681JA057	1/10W 680	1	EG, EC
R7401	DOGB103JA057	1/10W 10K	1	
R7444	ERJ3RED300V	1/16W 30	1	
R7445	ERJ3RBD682V	1/16W 6.8K	1	
R7446	ERJ3RBD202V	1/16W 2K	1	
R7447	ERJ3RBD273V	1/16W 27K	1	
R7448	ERJ3RBD392V	1/16W 3.9K	1	
R7449	ERJ3RBD103V	1/16W 10K	1	
R7802	ERDS2TJ102T	1/4W 1K	1	
R7804	DOGB471JA057	1/10W 470	1	
R7805	DOGB471JA057	1/10W 470	1	
R7811	DOGB472JA057	1/10W 4.7K	1	
R7812	ERJ3GEYJ155V	1/10W 30	1	EG
R7813	DOGB473JA057	1/10W 47K	1	EG
R7814	DOGB473JA057	1/10W 47K	1	EG
R7815	DOGB334JA057	1/10W 330K	1	EG
R7816	DOGB563JA057	1/10W 56K	1	EG
S6531	K0C111A00006	SWITCH,	1	
S6532	K0ZZ00000598	SWITCH	1	
T4001	G2A472C00003	TRANSFORMER	1	
TU7801	ENGF7713KF	TUNER	1	EG, EC
TU7801	ENV77R01D7F	TV TUNER	1	EB
W701	DOYBR0000020	1/10W 0	1	
W702	DOYBR0000020	1/10W 0	1	
W703	DOYBR0000020	1/10W 0	1	
W704	DOYBR0000020	1/10W 0	1	
W705	DOYBR0000020	1/10W 0	1	
W706	ERJ8GEY0R00V	1/4W 0	1	
W707	ERJ8GEY0R00V	1/4W 0	1	
W708	ERJ8GEY0R00V	1/4W 0	1	
W709	ERJ8GEY0R00V	1/4W 0	1	
W710	ERJ6GEY0R00Z	1/8W 0	1	
W711	ERJ6GEY0R00Z	1/8W 0	1	
W712	ERJ8GEY0R00V	1/4W 0	1	
W713	ERJ8GEY0R00V	1/4W 0	1	
W714	ERJ8GEY0R00V	1/4W 0	1	
W715	ERJ8GEY0R00V	1/4W 0	1	
W716	ERJ8GEY0R00V	1/4W 0	1	
W717	ERJ6GEY0R00Z	1/8W 0	1	
W718	ERJ8GEY0R00V	1/4W 0	1	
W719	ERJ8GEY0R00V	1/4W 0	1	
W720	DOYBR0000020	1/10W 0	1	
W721	ERJ8GEY0R00V	1/4W 0	1	
W722	ERJ8GEY0R00V	1/4W 0	1	
W723	ERJ8GEY0R00V	1/4W 0	1	
W724	ERJ8GEY0R00V	1/4W 0	1	
W725	ERJ8GEY0R00V	1/4W 0	1	
W726	ERJ8GEY0R00V	1/4W 0	1	
W727	ERJ8GEY0R00V	1/4W 0	1	
W728	ERJ8GEY0R00V	1/4W 0	1	
W729	ERJ8GEY0R00V	1/4W 0	1	
W730	ERJ8GEY0R00V	1/4W 0	1	
W731	ERJ8GEY0R00V	1/4W 0	1	
W732	ERJ8GEY0R00V	1/4W 0	1	
W733	ERJ8GEY0R00V	1/4W 0	1	

Ref. No.	Part No.	Part Name & Description	Pcs	Remarks
W734	D0YBR0000020	1/10W 0	1	
W735	D0YBR0000020	1/10W 0	1	
W736	D0YBR0000020	1/10W 0	1	
W737	D0YBR0000020	1/10W 0	1	
W738	D0YBR0000020	1/10W 0	1	
W739	D0YBR0000020	1/10W 0	1	
W740	ERJ6GEY0R00Z	1/8W 0	1	
W741	ERJ6GEY0R00Z	1/8W 0	1	
W742	ERJ8GEY0R00V	1/4W 0	1	
W743	ERJ8GEY0R00V	1/4W 0	1	
W744	D0YBR0000020	1/10W 0	1	
W745	D0YBR0000020	1/10W 0	1	
W746	D0YBR0000020	1/10W 0	1	
W747	ERJ6GEY0R00Z	1/8W 0	1	
W748	ERJ8GEY0R00V	1/4W 0	1	
W749	D0YBR0000020	1/10W 0	1	
W750	D0YBR0000020	1/10W 0	1	
W751	D0YBR0000020	1/10W 0	1	
W752	ERJ6GEY0R00Z	1/8W 0	1	
W753	D0YBR0000020	1/10W 0	1	
W754	D0YBR0000020	1/10W 0	1	
W755	ERJ6GEY0R00Z	1/8W 0	1	
W756	D0YBR0000020	1/10W 0	1	
W757	D0YBR0000020	1/10W 0	1	
W758	D0YBR0000020	1/10W 0	1	
W759	ERJ6GEY0R00Z	1/8W 0	1	
W760	D0YBR0000020	1/10W 0	1	
W762	D0YBR0000020	1/10W 0	1	
W763	ERJ6GEY0R00Z	1/8W 0	1	
W764	D0YBR0000020	1/10W 0	1	
W765	D0YBR0000020	1/10W 0	1	
W766	ERJ6GEY0R00Z	1/8W 0	1	
W767	D0YBR0000020	1/10W 0	1	
W768	D0YBR0000020	1/10W 0	1	
W769	D0YBR0000020	1/10W 0	1	
W770	D0YBR0000020	1/10W 0	1	
W771	ERJ6GEY0R00Z	1/8W 0	1	
W772	D0YBR0000020	1/10W 0	1	
W773	D0YBR0000020	1/10W 0	1	
W776	D0YBR0000020	1/10W 0	1	
W777	D0YBR0000020	1/10W 0	1	
W778	D0YBR0000020	1/10W 0	1	
W780	D0YBR0000020	1/10W 0	1	
W781	D0YBR0000020	1/10W 0	1	
W782	D0YBR0000020	1/10W 0	1	
W783	D0YBR0000020	1/10W 0	1	
W784	D0YBR0000020	1/10W 0	1	
W785	D0YBR0000020	1/10W 0	1	
W786	D0YBR0000020	1/10W 0	1	
W787	D0YBR0000020	1/10W 0	1	
W788	D0YBR0000020	1/10W 0	1	
W789	D0YBR0000020	1/10W 0	1	
W790	ERJ6GEY0R00Z	1/8W 0	1	
W791	ERJ6GEY0R00Z	1/8W 0	1	
W792	ERJ6GEY0R00Z	1/8W 0	1	
X3001	H0D443400040	OSCILLATOR	1	
X3002	H0D357400068	OSCILLATOR	1	
X6001	H0D120500009	OSCILLATOR	1	
X7301	H0H184500008	CRYSTAL OSCILLATOR	1	EG, EC
ZJ3001	VEE0U97	EARTH WIRE	1	
ZJ6101	K9ZZ00001279	EARTH PLATE	1	
ZJ7801	K9ZZ00001279	EARTH PLATE	1	
	RFKB71134A	DIG. INTERFACE P.C.B.	1	(RTL) EB
	RFKB71134AT	DIG. INTERFACE P.C.B.	1	(RTL) EG, EC
C9112	F1H1E104A030	25V 0.1U	1	
C9156	F1H1H1030006	50V 0.01U	1	
C9157	ECJ1VB1A225K	10V 2.2U	1	

Ref. No.	Part No.	Part Name & Description	Pcs	Remarks
C9158	F1H1E104A030	25V 0.1U	1	
C9201	ECJ1VC1H221J	50V 220P	1	
C9202	ECJ1VC1H221J	50V 220P	1	
C9301	F1H1H104A731	50V 0.1U	1	
C9302	ECQV1H104JL3	50V 0.1U	1	
C9303	F2A1C221A637	16V 220U	1	
C9305	F2A1A221A550	10V 220U	1	
C9306	F1H1C104A008	16V 0.1U	1	
C9309	ECJ2VC1H330J	50V 33P	1	
C9310	ECJ2VC1H330J	50V 33P	1	
C9311	F2A1C220B173	16V 22U	1	
C9312	F2A1C220B173	16V 22U	1	
C9331	F2A1C470A637	16V 47U	1	
C9332	F2A1C470A637	16V 47U	1	
C9333	F2A1C101A637	16V 100U	1	
C9336	F1H1H104A731	50V 0.1U	1	
C9337	F2A1A221A550	10V 220U	1	
C9701	F1J0J475A008	6.3V 4.7U	1	
C9704	F1H1H1030006	50V 0.01U	1	
C9706	F2A0J101A825	6.3V 100U	1	
C9707	F1H1E104A030	25V 0.1U	1	
C9708	F1H1H1030006	50V 0.01U	1	
C9710	ECJ1VC1H100D	50V 10P	1	
C9711	ECJ1VC1H100D	50V 10P	1	
C9712	ECJ1VC1H100D	50V 10P	1	
C9713	F1H1C104A042	16V 0.1U	1	
C9714	F1H1C104A008	16V 0.1U	1	
C9715	F1H1H1030006	50V 0.01U	1	
C9716	F1H1H1030006	50V 0.01U	1	
C9717	F1H1H1030006	50V 0.01U	1	
C9719	F1H1H1030006	50V 0.01U	1	
C9720	F1H1H104A731	50V 0.1U	1	
C9722	F1H1C104A042	16V 0.1U	1	
C9723	F2A0J470A599	6.3V 47U	1	
C9724	F1H1C104A042	16V 0.1U	1	
C9725	F1H1A1050029	10V 1U	1	
C9726	F1H1E104A030	25V 0.1U	1	
C9727	F2A1C121A453	16V 120U	1	
C9730	F1H1H104A731	50V 0.1U	1	
C9733	F1H1H1010005	50V 100P	1	
C9735	F1H1H1030006	50V 0.01U	1	
C9736	F1H1H1030006	50V 0.01U	1	
C9737	F4D55473A013	5.5V 0.047	1	
C9738	ECJ1VC1H180J	50V 18P	1	
C9739	ECJ1VC1H180J	50V 18P	1	
C9741	F1H1H104A731	50V 0.1U	1	
C9742	ECJ1VC1H180J	50V 18P	1	
C9744	F2A0J221A826	6.3V 220U	1	
C9745	ECJ1VC1H180J	50V 18P	1	
C9746	F2A0J221A826	6.3V 220U	1	
C9747	F1H1C104A042	16V 0.1U	1	
C9748	F1H1C104A042	16V 0.1U	1	
C9749	F1H1H104A731	50V 0.1U	1	
C9750	F1H1H104A731	50V 0.1U	1	
C9752	ECJ1VC1H470J	50V 47P	1	
C9753	ECJ1VC1H470J	50V 47P	1	
C9754	F1H1A1050029	10V 1U	1	
C9756	F1H1H1010005	50V 100P	1	
C9757	F1J0J475A008	6.3V 4.7U	1	
C9759	F2A1C100A111	16V 10U	1	
C9766	F1H1C104A042	16V 0.1U	1	
C9768	F2A1C470A111	16V 47U	1	
C9771	F2A1C470A637	16V 47U	1	
C9772	F2A1C470A637	16V 47U	1	
C9778	F1H1H1030006	50V 0.01U	1	
C9779	F1H1H1030006	50V 0.01U	1	
C9780	F1H1H1030006	50V 0.01U	1	
C9781	F1H1H1030006	50V 0.01U	1	
C9785	F2A1C471A628	16V 470U	1	
C9786	ECJ1VC1H220J	50V 22P	1	
C9787	ECJ1VC1H220J	50V 22P	1	
C9790	F1H1C104A042	16V 0.1U	1	
C9791	F1H1C104A042	16V 0.1U	1	

Ref. No.	Part No.	Part Name & Description	Pcs	Remarks
C9792	FLJ0J106A014	6.3V 10U	1	
C9793	F1H1H1030006	50V 0.01U	1	
C9794	F1H1H1030006	50V 0.01U	1	
C9795	F1H1H1030006	50V 0.01U	1	
C11120	ECQU2A683MLC	0.068U	1	△
C11121	ECQU2A223MLC	0.022U	1	△
C11122	F1B2G1020002	1000P	1	△
C11123	F1B2G1020002	1000P	1	△
C11124	F1B2G1020002	1000P	1	△
C11143	F2B2G680A050	400V 68U	1	
C11150	F2A1E1010103	25V 0.01U	1	
C11151	F1B3A101A009	50V 100	1	
C11152	F1H1H1010005	50V 100P	1	
C11153	F1H1H222A219	50V 2200P	1	
C11154	F1H1H1020005	50V 0.001U	1	
C11170	F2A1V6800002	35V 68U	1	
C11171	F1B3A101A009	50V 100	1	
C11172	ECJ2VC1H101J	50V 100U	1	
C11173	F1H1H222A219	50V 2200P	1	
C11174	F1H1H1020005	50V 0.001U	1	
C11200	F1H1C104A042	16V 0.1U	1	
C11201	F1H1C473A071	16V 0.047U	1	
C11251	F2A1C5610006	16V 560U	1	
C11252	F2A1C1210017	16V 120P	1	
C11270	F2A1C2220081	16V 2200P	1	
C11272	F2A1C8210008	16V 820U	1	
C11273	F1H1C105A095	16V 1U	1	
C11274	F2A1E1010103	25V 0.01U	1	
C11275	ECJ1VB1A105K	10V 1U	1	
C11276	ECJ1VB1A105K	10V 1U	1	
C11277	F2A1A4700041	10V 47U	1	
C11278	F2A1E1010103	25V 0.01U	1	
C11300	F1H1C104A042	16V 0.1U	1	
C11301	F1H1C473A071	16V 0.047U	1	
C11370	F2A1C5610006	16V 560U	1	
C11371	F1H1C105A095	16V 1U	1	
C11372	F1H1C104A042	16V 0.1U	1	
C11373	F1H1C104A042	16V 0.1U	1	
C11374	ECJ1VC1H181J	50V 180P	1	
C11376	F1H1H1030006	50V 0.01U	1	
C11377	F2A1C4710079	16V 470U	1	
C11379	F2A1A4700041	10V 47U	1	
C11401	F2A1C1210017	16V 120P	1	
C11402	ECJ1VB1A105K	10V 1U	1	
C11403	F1H1H1030006	50V 0.01U	1	
C11404	ECJ1VB1A105K	10V 1U	1	
C11601	F2A1A1820007	10V 1800U	1	
C11602	F2A1A6810022	10V 680U	1	
C11701	F2A1C5610006	16V 560U	1	
C11702	F1H1C105A095	16V 1U	1	
C11703	F1H1C104A042	16V 0.1U	1	
C11704	F1H1C104A042	16V 0.1U	1	
C11705	ECJ1VC1H181J	50V 180P	1	
C11707	F1H1H1030006	50V 0.01U	1	
C11708	F2A1A6810022	10V 680U	1	
C11751	F2A1C1210017	16V 120P	1	
C11753	F2A1C1210017	16V 120P	1	
C11801	F2A1H5600018	50V 56P	1	
C11901	F2A1H5600018	50V 56P	1	
D9104	MAZ40390HF	DIODE	1	
D9105	B0AACK000004	DIODE	1	
D9106	B0JACE000001	DIODE	1	
D9107	B0AACK000004	DIODE	1	
D9202	B0ACCK000005	DIODE	1	
D9302	MA3Z142DOLG	DIODE	1	
D9702	MA2C72300F	DIODE	1	
D9705	MAZ4180NMF	DIODE	1	
D11101	B0EBKR000032	DIODE	1	
D11141	BOHADV000001	DIODE	1	
D11142	BOBB20000004	DIODE	1	
D11143	BOBB20000004	DIODE	1	
D11151	B0AADM000003	DIODE	1	

Ref. No.	Part No.	Part Name & Description	Pcs	Remarks
D11152	MAZ81300HL	DIODE	1	
D11155	MAZ73000BC	DIODE	1	
D11156	MA2J11100L	DIODE	1	
D11157	MAZ81600ML	DIODE	1	
D11171	B0AADM000003	DIODE	1	
D11172	B0BC01200019	DIODE	1	
D11175	MAZ73000BC	DIODE	1	
D11176	MA2J11100L	DIODE	1	
D11177	B0AADM000003	DIODE	1	
D11201	MA2J11100L	DIODE	1	
D11202	MA2J11100L	DIODE	1	
D11250	B0JCNG000003	DIODE	1	
D11270	B0JCNG000003	DIODE	1	
D11271	B0JCNG000003	DIODE	1	
D11272	B0JCNG000003	DIODE	1	
D11370	B0JCPD000021	DIODE	1	
D11400	B0JAME000025	DIODE	1	
D11401	B0JAME000025	DIODE	1	
D11600	B0JAQE000004	DIODE	1	
D11601	B0JAQE000004	DIODE	1	
D11701	B0JCPD000021	DIODE	1	
D11800	B0AADM000003	DIODE	1	
D11801	B0EAKL000062	DIODE	1	
D11900	B0AADM000003	DIODE	1	
F11101	K5D202BK0005	FUSE	1	△
IC9301	CODBAHD00013	IC	1	
IC9302	C0ABBB000216	IC	1	
IC9305	C0ABBB000230	IC	1	
IC9700	B3ZAZ0000017	IC	1	
IC9701	C2CJBG0000748	IC	1	
IC9702	C0EBE0000194	IC	1	
IC9703	C0EBJ0000336	IC	1	
IC9705	RFKFM4016K	IC	1	EB
IC9705	RFKFM4016KT	IC	1	EG, EC
IC9706	C0EBE0000504	IC	1	
IC9707	C0EBJ0000143	IC	1	
IC9708	C0DBEYG00002	IC	1	
IC11150	CODACZH00026	IC	1	
IC11170	CODACZH00026	IC	1	
IC11200	C0DAEMZ00001	IC	1	
IC11300	C0DAEMZ00001	IC	1	
IC11370	C0DBAZZ00132	IC	1	
IC11400	C0CBCBD00048	IC	1	
IC11700	C0DBAZZ00132	IC	1	
IC11750	C0DBEKG00003	IC	1	
IP9102	ERBSE0R50U	IC PROTECTOR	1	△
IP11400	ERBSE1R50U	IC PROTECTOR	1	△
IP11800	ERBSE1R00U	IC PROTECTOR	1	△
K9721	D0YBR0000020	1/10W 0	1	
L9105	G0C680JA0019	COIL 68UH	1	
L9106	G0C820JA0019	COIL	1	
L9700	G0C220JA0019	COIL 22UH	1	
L9701	G0A100HA0023	COIL 10UH	1	
L9703	G0A100HA0023	COIL 10UH	1	
L11120	G0B233D00001	COIL	1	△
L11121	G0B233D00001	COIL	1	△
L11251	G0A100HA0023	COIL 10UH	1	
L11270	G0A100H00025	COIL 10UH	1	
L11271	G0A100HA0023	COIL 10UH	1	
L11370	G0A100HA0023	COIL 10UH	1	
L11371	G0A150ZA0041	COIL 15UH	1	
L11372	G0A100HA0023	COIL 10UH	1	
L11373	G0A100HA0023	COIL 10UH	1	
L11601	G0A100HA0023	COIL 10UH	1	
L11700	G0A100HA0023	COIL 10UH	1	
L11701	G0A220ZA0041	COIL 22UH	1	
L11702	G0A100HA0023	COIL 10UH	1	

Ref. No.	Part No.	Part Name & Description	Pcs	Remarks
LB9700	J0JCC0000103	COIL	1	
LB9701	J0JHC0000032	COIL	1	
LB9702	D0YBR0000020	1/10W 0	1	
LB9703	J0JCC0000103	COIL	1	
LB9704	J0JKB0000012	COIL	1	
LB9705	D0YBR0000020	1/10W 0	1	
LB9706	J0JCC0000060	COIL	1	
LB9707	J0JCC0000103	COIL	1	
LB9709	D0YBR0000020	1/10W 0	1	
LB9711	J0JKB0000012	COIL	1	
LB9712	J0JKB0000012	COIL	1	
LB9713	J0JCC0000103	COIL	1	
LB9714	J0JCC0000103	COIL	1	
LB9715	D0YBR0000020	1/10W 0	1	
LB9717	D0YBR0000020	1/10W 0	1	
LB9718	J0JHC0000032	COIL	1	
LB9719	D0YBR0000020	1/10W 0	1	
LB9720	J0JDC0000092	COIL	1	
LB9721	J0JHC0000032	COIL	1	
LB9723	J0JCC0000103	COIL	1	
LB9724	J0JHC0000032	COIL	1	
LB11122	J0JKB0000003	COIL	1	
LB11123	J0JKB0000003	COIL	1	
LB11124	J0JHC0000048	FILTER	1	
LB11125	J0JGC0000020	COIL	1	
LB11126	J0JGC0000020	COIL	1	
LB11150	J0JHC0000048	FILTER	1	
LB11176	J0JHC0000048	FILTER	1	
LB11370	J0JHC0000048	FILTER	1	
LB11400	J0JHC0000048	FILTER	1	
LB11701	J0JHC0000048	FILTER	1	
LB11802	J0JHC0000048	FILTER	1	
LB11900	J0JHC0000048	FILTER	1	
P9101	K1KA19A00007	CONNECTOR (19P)	1	
P9102	K1KA19A00007	CONNECTOR (19P)	1	
P9103	K1KY23AA0606	CONNECTOR (23P)	1	
P9104	K1KA13A000074	CONNECTOR (13P)	1	
P9700	K1KY08AA0107	CONNECTOR (8P)	1	
P9701	K1KA03AA0301	CONNECTOR (3P)	1	
P9703	K1KA88A00003	CONNECTOR (88P)	1	
P9705	K1KA06AA0188	CONNECTOR	1	
P9707	K1KA04AA0180	CONNECTOR (4P)	1	
P11101	K2AA2H000007	AC INLET	1	△
PS9701	K1KB20B00040	CONNECTOR	1	
Q9101	2SD1819A0L	TRANSISTOR	1	
Q9106	2SD0601A0L	TRANSISTOR	1	
Q9202	2SD1819A0L	TRANSISTOR	1	
Q9203	2SD1819A0L	TRANSISTOR	1	
Q9204	2SD1819A0L	TRANSISTOR	1	
Q9301	2SD132800L	TRANSISTOR	1	
Q9302	2SD132800L	TRANSISTOR	1	
Q9701	2SB1218A0L	TRANSISTOR	1	
Q9702	2SD1819A0L	TRANSISTOR	1	
Q9703	2SD1819A0L	TRANSISTOR	1	
Q9704	B1ADGG000004	TRANSISTOR	1	
Q9705	2SB1218A0L	TRANSISTOR	1	
Q9706	2SD1819A0L	TRANSISTOR	1	
Q9707	2SD0601A0L	TRANSISTOR	1	
Q9708	2SD132800L	TRANSISTOR	1	
Q11200	B3PBA0000454	TRANSISTOR	1	△
Q11201	2SD0601ASL	TRANSISTOR	1	
Q11270	B1DHED000008	TRANSISTOR	1	
Q11271	B1DHDC000027	TRANSISTOR	1	
Q11300	B3PBA0000454	TRANSISTOR	1	△
Q11370	B1DHED000008	TRANSISTOR	1	
Q11700	B1DHDD000022	TRANSISTOR	1	
QR9301	UNR5111J0L	TRANSISTOR	1	
QR9701	UNR5212J0L	TRANSISTOR	1	
QR9703	UNR5210J0L	TRANSISTOR	1	

Ref. No.	Part No.	Part Name & Description	Pcs	Remarks
QR9705	UNR5213J0L	TRANSISTOR	1	
QR9706	UNR5213J0L	TRANSISTOR	1	
QR9707	UNR5113J0L	TRANSISTOR	1	
QR11200	UNR5211J0L	TRANSISTOR	1	
QR11270	UNR5213J0L	TRANSISTOR	1	
QR11271	UNR5213J0L	TRANSISTOR	1	
QR11700	UNR5213J0L	TRANSISTOR	1	
QR11701	UNR5213J0L	TRANSISTOR	1	
R9102	D0GB103JA057	1/10W 10K	1	
R9132	D0GB220JA057	1/10W 22	1	
R9143	D0GB331JA057	1/10W 330	1	
R9144	D0GB473JA057	1/10W 47K	1	
R9145	D0GB223JA057	1/10W 22K	1	
R9146	D0GB102JA057	1/10W 1K	1	
R9201	D0GB221JA057	1/10W 220	1	
R9205	D0GB223JA057	1/10W 22K	1	
R9207	D0GB153JA057	1/10W 15K	1	
R9208	D0GB104JA057	1/10W 100K	1	
R9209	D0GB104JA057	1/10W 100K	1	
R9210	D0GB224JA057	1/10W 220K	1	
R9211	D0GB225JA057	1/10W 2200K	1	
R9212	D0GB273JA057	1/10W 27K	1	
R9213	D0GB473JA057	1/10W 47K	1	
R9214	D0GB472JA057	1/10W 4.7K	1	
R9303	D0GB272JA057	1/10W 2.7K	1	
R9304	D0GB272JA057	1/10W 2.7K	1	
R9310	D0GB473JA057	1/10W 47K	1	
R9311	D0GB473JA057	1/10W 47K	1	
R9312	D0GB821JA057	1/10W 820	1	
R9313	D0GB101JA057	1/10W 100	1	
R9314	D0GB101JA057	1/10W 100	1	
R9315	D0GB821JA057	1/10W 820	1	
R9331	D0HB103ZA002	1/10W 10K	1	
R9333	D0HB103ZA002	1/10W 10K	1	
R9335	D0HB912ZA002	1/10W 9.1K	1	
R9336	D0HB912ZA002	1/10W 9.1K	1	
R9337	D0HB153ZA002	1/10W 15K	1	
R9338	D0HB153ZA002	1/10W 15K	1	
R9701	D0GB103JA057	1/10W 10K	1	
R9702	D0GB103JA057	1/10W 10K	1	
R9703	D0GB101JA057	1/10W 100	1	
R9704	D0GB102JA057	1/10W 1K	1	
R9705	D0GB101JA057	1/10W 100	1	
R9706	ERJ3GEYF562V	1/10W 5.6K	1	
R9707	D0GB101JA057	1/10W 100	1	
R9708	D0GB102JA057	1/10W 1K	1	
R9709	D0GB472JA057	1/10W 4.7K	1	
R9710	ERJ6GEY0R00Z	1/8W 0	1	
R9711	D0GB474JA057	1/10W 470K	1	
R9712	D0GB153JA057	1/10W 15K	1	
R9713	D0GB101JA057	1/10W 100	1	
R9714	D0GB101JA057	1/10W 100	1	
R9715	D0GB101JA057	1/10W 100	1	
R9716	D0GB101JA057	1/10W 100	1	
R9717	D0GB104JA057	1/10W 100K	1	
R9718	ERJ6GEY0R00Z	1/8W 0	1	
R9720	D0GB101JA057	1/10W 100	1	
R9721	D0GB101JA057	1/10W 100	1	
R9722	D0GB101JA057	1/10W 100	1	
R9724	D0GB101JA057	1/10W 100	1	
R9725	D0GB103JA057	1/10W 10K	1	
R9726	D0GB101JA057	1/10W 100	1	
R9727	D0GB101JA057	1/10W 100	1	
R9728	D0GB101JA057	1/10W 100	1	
R9729	D0GB101JA057	1/10W 100	1	
R9730	D1BB15010002	2W 150	1	
R9731	D0GB103JA057	1/10W 10K	1	
R9736	D0GB473JA057	1/10W 47K	1	
R9738	D0GB223JA057	1/10W 22K	1	
R9739	D0GB104JA057	1/10W 100K	1	
R9741	D0GB181JA057	1/10W 180	1	
R9742	D0GB101JA057	1/10W 100	1	

Ref. No.	Part No.	Part Name & Description	Pcs	Remarks
R9744	DOGB101JA057	1/10W 100	1	
R9745	DOGB101JA057	1/10W 100	1	
R9747	DOGB101JA057	1/10W 100	1	
R9748	DOGB101JA057	1/10W 100	1	
R9749	DOGB101JA057	1/10W 100	1	
R9750	DOGB101JA057	1/10W 100	1	
R9751	DOGB101JA057	1/10W 100	1	
R9752	DOGB103JA057	1/10W 10K	1	
R9753	D1BB3902A010	2W 3.9K	1	
R9754	D1BB4302A010	2W 4.3K	1	
R9755	DOYBR0000020	1/10W 0	1	
R9756	DOGB822JA057	1/10W 8.2K	1	
R9757	DOGB822JA057	1/10W 8.2K	1	
R9758	DOGB822JA057	1/10W 8.2K	1	
R9759	DOGB472JA057	1/10W 4.7K	1	
R9760	DOGB472JA057	1/10W 4.7K	1	
R9761	DOGB101JA057	1/10W 100	1	
R9764	DOGB101JA057	1/10W 100	1	
R9765	DOGB332JA057	1/10W 3.3K	1	
R9766	DOGB101JA057	1/10W 100	1	
R9767	DOYBR0000020	1/10W 0	1	
R9768	DOGB681JA057	1/10W 680	1	
R9769	DOGB101JA057	1/10W 100	1	
R9770	DOGB221JA057	1/10W 220	1	
R9771	DOGB221JA057	1/10W 220	1	
R9772	DOGB473JA057	1/10W 47K	1	
R9773	DOGB202JA057	1/10W 2K	1	
R9774	DOGB202JA057	1/10W 2K	1	
R9775	DOGB103JA057	1/10W 10K	1	
R9776	DOGB101JA057	1/10W 100	1	
R9777	DOGB101JA057	1/10W 100	1	
R9779	DOGB392JA057	1/10W 3.9K	1	
R9780	DOGB102JA057	1/10W 1K	1	
R9781	DOGB104JA057	1/10W 100K	1	
R9782	DOGB472JA057	1/10W 4.7K	1	
R9783	DOGB104JA057	1/10W 100K	1	
R9784	DOGB101JA057	1/10W 100	1	
R9785	D1BB1502A010	2W 1.5K	1	
R9786	DOGB101JA057	1/10W 100	1	
R9788	DOGB153JA057	1/10W 15K	1	
R9789	DOGB101JA057	1/10W 100	1	
R9790	DOGB101JA057	1/10W 100	1	
R9791	ERDS2TJ221T	1/4W 220	1	
R9792	ERJ3RBD222V	1/16W 2.2K	1	
R9793	ERJ3RBD272V	1/16W 2.7K	1	
R9794	DOGB472JA057	1/10W 4.7K	1	
R9795	DOYBR0000020	1/10W 0	1	
R9796	DOGB472JA057	1/10W 4.7K	1	
R9798	DOGB472JA057	1/10W 4.7K	1	
R9799	DOGB103JA057	1/10W 10K	1	
R9800	DOGB101JA057	1/10W 100	1	
R9801	DOGB101JA057	1/10W 100	1	
R9802	DOGB101JA057	1/10W 100	1	
R9810	DOGB472JA057	1/10W 4.7K	1	
R9811	DOGB472JA057	1/10W 4.7K	1	
R9814	DOGB101JA057	1/10W 100	1	
R9815	DOGB101JA057	1/10W 100	1	
R9816	DOGB101JA057	1/10W 100	1	
R9817	DOGB101JA057	1/10W 100	1	
R9818	DOGB103JA057	1/10W 10K	1	
R9824	DOGB101JA057	1/10W 100	1	
R9825	DOGB101JA057	1/10W 100	1	
R9829	DOGB472JA057	1/10W 4.7K	1	
R9834	DOGB331JA057	1/10W 330	1	
R9835	DOGB331JA057	1/10W 330	1	
R9836	DOYBR0000020	1/10W 0	1	
R9837	DOYBR0000020	1/10W 0	1	
R9838	DOYBR0000020	1/10W 0	1	
R9839	DOYBR0000020	1/10W 0	1	
R9840	DOYBR0000020	1/10W 0	1	
R9841	DOYBR0000020	1/10W 0	1	
R9842	DOYBR0000020	1/10W 0	1	
R9843	DOYBR0000020	1/10W 0	1	

Ref. No.	Part No.	Part Name & Description	Pcs	Remarks
R9845	ERJ3RBD303V	1/16W 30K	1	
R9846	ERJ3RBD622V	1/16W 6.2K	1	
R9847	ERJ3RBD103V	1/16W 10K	1	
R11150	ERJ6GEYJ470V	1/8W 47	1	
R11151	DOGB472JA057	1/10W 4.7K	1	
R11152	DOGB103JA057	1/10W 10K	1	
R11153	ERJ6GEYJ470V	1/8W 47	1	
R11154	ERJ3RBD153V	1/16W 15K	1	
R11155	ERJ3RBD153V	1/16W 15K	1	
R11156	ERJ3RBD182V	1/16W 1.8K	1	
R11157	DOYBR0000020	1/10W 0	1	
R11158	ERDS2TJ221T	1/4W 220	1	
R11170	ERJ6GEYJ6R8V	1/8W 6.8	1	
R11171	DOGB682JA057	1/10W 6.8K	1	
R11172	DOGB103JA057	1/10W 10K	1	
R11173	ERJ6GEYJ6R8V	1/8W 6.8	1	
R11174	ERJ3RBD133V	1/16W 13K	1	
R11175	ERJ3RBD133V	1/16W 13K	1	
R11176	ERJ3RBD201V	1/16W 200	1	
R11177	ERJ3RBD821V	1/16W 820	1	
R11200	ERJ3RBD101V	1/16W 100	1	
R11201	ERJ3RBD912V	1/16W 9.1K	1	
R11205	ERJ3RBD563V	1/16W 56K	1	
R11206	ERJ3RBD242V	1/16W 2.4K	1	
R11207	DOGB103JA057	1/10W 10K	1	
R11208	ERJ3GEYJ242V	1/10W 2.4K	1	
R11209	DOGB102JA057	1/10W 1K	1	
R11210	DOGB102JA057	1/10W 1K	1	
R11211	DOGB103JA057	1/10W 10K	1	
R11212	DOGB472JA057	1/10W 4.7K	1	
R11270	DOGB472JA057	1/10W 4.7K	1	
R11271	DOGB472JA057	1/10W 4.7K	1	
R11272	DOGB822JA057	1/10W 8.2K	1	
R11273	DOGB823JA057	1/10W 82K	1	
R11274	ERDS2TJ102T	1/4W 1K	1	
R11300	ERJ3RBD911V	1/16W 910	1	
R11301	ERJ3RBD242V	1/16W 2.4K	1	
R11306	ERJ3RBD242V	1/16W 2.4K	1	
R11307	DOGB103JA057	1/10W 10K	1	
R11308	DOGB681JA057	1/10W 680	1	
R11309	DOGB102JA057	1/10W 1K	1	
R11310	DOGB102JA057	1/10W 1K	1	
R11371	DOGB513JA057	1/10W 51K	1	
R11372	D1BDR033A101	33	1	
R11373	ERJ3RBD153V	1/16W 15K	1	
R11374	ERJ3RBD911V	1/16W 910	1	
R11375	ERJ3RBD512V	1/16W 5.1K	1	
R11700	DOGB103JA057	1/10W 10K	1	
R11701	DOGB513JA057	1/10W 51K	1	
R11702	D1BDR039A101	1/3W 0.039	1	
R11703	ERJ3RBD821V	1/16W 820	1	
R11704	ERJ3RBD103V	1/16W 10K	1	
R11705	ERJ3RBD472V	1/16W 4.7K	1	
R11706	DOGB471JA057	1/10W 470	1	
R11750	DOYBR0000020	1/10W 0	1	
R11751	ERJ3RBD393V	1/16W 39K	1	
R11752	ERJ3RBD243V	1/16W 24K	1	
T11150	G4DYA0000088	TRANSFORMER	1	△
T11170	G4DYA0000089	TRANSFORMER	1	△
VA11110	ERZV10D471C2	VARISTOR	1	△
W501	DOYBR0000020	1/10W 0	1	
W502	ERJ6GEY0R00Z	1/8W 0	1	
W503	DOYBR0000020	1/10W 0	1	
W504	DOYBR0000020	1/10W 0	1	
W505	DOYBR0000020	1/10W 0	1	
W506	DOYBR0000020	1/10W 0	1	
W507	ERJ6GEY0R00Z	1/8W 0	1	
W508	ERJ6GEY0R00Z	1/8W 0	1	
W509	DOYBR0000020	1/10W 0	1	
W510	ERJ6GEY0R00Z	1/8W 0	1	

Ref. No.	Part No.	Part Name & Description	Pcs	Remarks
W511	D0YBR0000020	1/10W 0	1	
W512	ERJ6GEY0R00Z	1/8W 0	1	
W513	D0YBR0000020	1/10W 0	1	
W514	D0YBR0000020	1/10W 0	1	
W515	ERJ6GEY0R00Z	1/8W 0	1	
W516	D0YBR0000020	1/10W 0	1	
W517	D0YBR0000020	1/10W 0	1	
W518	D0YBR0000020	1/10W 0	1	
W519	D0YBR0000020	1/10W 0	1	
W520	D0YBR0000020	1/10W 0	1	
W521	D0YBR0000020	1/10W 0	1	
W522	D0YBR0000020	1/10W 0	1	
W523	D0YBR0000020	1/10W 0	1	
W524	D0YBR0000020	1/10W 0	1	
W525	D0YBR0000020	1/10W 0	1	
W526	D0YBR0000020	1/10W 0	1	
W527	D0YBR0000020	1/10W 0	1	
W528	D0YBR0000020	1/10W 0	1	
W529	D0YBR0000020	1/10W 0	1	
W530	D0YBR0000020	1/10W 0	1	
W531	D0YBR0000020	1/10W 0	1	
W532	D0YBR0000020	1/10W 0	1	
W533	D0YBR0000020	1/10W 0	1	
W534	D0YBR0000020	1/10W 0	1	
W535	D0YBR0000020	1/10W 0	1	
W536	D0YBR0000020	1/10W 0	1	
W537	D0YBR0000020	1/10W 0	1	
W538	D0YBR0000020	1/10W 0	1	
W539	D0YBR0000020	1/10W 0	1	
W540	D0YBR0000020	1/10W 0	1	
W541	D0YBR0000020	1/10W 0	1	
W542	D0YBR0000020	1/10W 0	1	
W543	D0YBR0000020	1/10W 0	1	
W544	D0YBR0000020	1/10W 0	1	
W545	D0YBR0000020	1/10W 0	1	
W546	ERJ6GEY0R00Z	1/8W 0	1	
W547	ERJ6GEY0R00Z	1/8W 0	1	
W548	ERJ6GEY0R00Z	1/8W 0	1	
W549	ERJ6GEY0R00Z	1/8W 0	1	
W550	ERJ6GEY0R00Z	1/8W 0	1	
W551	ERJ6GEY0R00Z	1/8W 0	1	
W552	ERJ6GEY0R00Z	1/8W 0	1	
W553	ERJ6GEY0R00Z	1/8W 0	1	
W554	D0YBR0000020	1/10W 0	1	
W555	ERJ6GEY0R00Z	1/8W 0	1	
W556	ERJ6GEY0R00Z	1/8W 0	1	
W557	ERJ6GEY0R00Z	1/8W 0	1	
W558	D0YBR0000020	1/10W 0	1	
W559	D0YBR0000020	1/10W 0	1	
W560	D0YBR0000020	1/10W 0	1	
W561	D0YBR0000020	1/10W 0	1	
W562	D0YBR0000020	1/10W 0	1	
W563	ERJ6GEY0R00Z	1/8W 0	1	
W564	ERJ6GEY0R00Z	1/8W 0	1	
X9701	H0D100500018	CRYSTAL OSCILLATOR	1	
X9702	H0A327200108	CRYSTAL OSCILLATOR	1	
ZA11103	EYF52BCY	FUSE HOLDER	1	
ZA11104	EYF52BCY	FUSE HOLDER	1	
ZA11150	VSC5606-A	HEAT SINK	1	
ZA11151	XYN3+J8FJ	SCREW	1	
ZA11170	VSC5606-A	HEAT SINK	1	
ZA11171	XYN3+J8FJ	SCREW	1	
ZJ9101	K9ZZ00001279	EARTH PLATE	1	
ZJ9102	K9ZZ00001279	EARTH PLATE	1	
ZJ9103	K9ZZ00001279	EARTH PLATE	1	
ZJ9104	K9ZZ00001279	EARTH PLATE	1	
ZJ9105	K9ZZ00001279	EARTH PLATE	1	
■	VEP72120A	FL DRIVE P.C.B.	1	(RTL)

Ref. No.	Part No.	Part Name & Description	Pcs	Remarks
C7501	F1H1E104A030	25V 0.1U	1	
C7502	F2A0J470A824	6.3V 47U	1	
C7506	F1H1H104A731	50V 0.1U	1	
D7502	B3ACA0000273	DIODE	1	
D7503	B3ADA0000173	DIODE	1	
D7504	B3AAA0000752	DIODE	1	
D7505	B3ABA0000595	DIODE	1	
D7506	B3AEA0000069	DIODE	1	
DP7501	A2BB00000165	DISPLAY TUBE	1	
IC7501	C0HBB0000057	IC	1	
L7501	G0C220JA0019	COIL 22UH	1	
LB7501	J0JGC0000020	COIL	1	
LB7502	J0JGC0000020	COIL	1	
LB7503	J0JGC0000020	COIL	1	
LB7504	J0JGC0000020	COIL	1	
LB7505	J0JGC0000020	COIL	1	
PP7501	K1KA20B00132	CONNECTOR (20P)	1	
Q7502	2SD0601A0L	TRANSISTOR	1	
QR7502	UNR5211J0L	TRANSISTOR	1	
QR7503	UNR5211J0L	TRANSISTOR	1	
QR7504	UNR5211J0L	TRANSISTOR	1	
QR7505	UNR5211J0L	TRANSISTOR	1	
QR7506	UNR5211J0L	TRANSISTOR	1	
R7501	D0GB183JA057	1/10W 18K	1	
R7502	D0GB391JA057	1/10W 390	1	
R7503	D0GB391JA057	1/10W 390	1	
R7504	D0GB271JA057	1/10W 2.7K	1	
R7505	D0GB183JA057	1/10W 18K	1	
R7506	D0GB332JA057	1/10W 3.3K	1	
R7507	D0GB152JA057	1/10W 1.5K	1	
R7508	D0GB152JA057	1/10W 1.5K	1	
R7509	D0GB152JA057	1/10W 1.5K	1	
R7510	D0GB222JA057	1/10W 2.2K	1	
R7511	D0GB332JA057	1/10W 3.3K	1	
R7512	D0GB272JA057	1/10W 2.7K	1	
R7513	D0GB392JA057	1/10W 3.9K	1	
R7514	D0GB822JA057	1/10W 8.2K	1	
R7515	D0GB183JA057	1/10W 18K	1	
R7519	D0GB101JA057	1/10W 100	1	
R7520	D0GB101JA057	1/10W 100	1	
R7521	D0GB101JA057	1/10W 100	1	
R7522	D0GB473JA057	1/10W 47K	1	
R7523	D0YBR0000020	1/10W 0	1	
R7524	D0GB103JA057	1/10W 10K	1	
R7525	ERJ3RBD104V	1/16W 100K	1	
R7526	D0GB681JA057	1/10W 680	1	
R7527	D0GB471JA057	1/10W 470	1	
R7528	D0YBR0000020	1/10W 0	1	
S7501	EVQ11G07K	SWITCH,	1	
S7502	EVQ11G07K	SWITCH,	1	
S7503	EVQ11G07K	SWITCH,	1	
S7504	EVQ11G07K	SWITCH,	1	
S7505	EVQ11G07K	SWITCH,	1	
S7506	EVQ11G07K	SWITCH,	1	
S7507	EVQ11G07K	SWITCH,	1	
S7508	EVQ11G07K	SWITCH,	1	
S7509	EVQ11G07K	SWITCH,	1	
S7510	EVQ11G07K	SWITCH,	1	
S7511	EVQ11G07K	SWITCH,	1	
S7512	EVQ11G07K	SWITCH,	1	
S7513	EVQ11G07K	SWITCH,	1	
W751	ERJ6GEY0R00Z	1/8W 0	1	

Ref. No.	Part No.	Part Name & Description	Pcs	Remarks
W753	ERJ6GEY0R00Z	1/8W 0	1	
W754	ERJ6GEY0R00Z	1/8W 0	1	
W756	ERJ6GEY0R00Z	1/8W 0	1	
W757	ERJ6GEY0R00Z	1/8W 0	1	
W758	ERJ6GEY0R00Z	1/8W 0	1	
W760	ERJ6GEY0R00Z	1/8W 0	1	
W761	ERJ6GEY0R00Z	1/8W 0	1	
W762	ERJ6GEY0R00Z	1/8W 0	1	
W764	ERJ6GEY0R00Z	1/8W 0	1	
W765	ERJ6GEY0R00Z	1/8W 0	1	
W767	ERJ6GEY0R00Z	1/8W 0	1	
W768	ERJ6GEY0R00Z	1/8W 0	1	
W769	ERJ6GEY0R00Z	1/8W 0	1	
W770	ERJ6GEY0R00Z	1/8W 0	1	
W772	ERJ6GEY0R00Z	1/8W 0	1	
W773	ERJ6GEY0R00Z	1/8W 0	1	
W774	ERJ6GEY0R00Z	1/8W 0	1	
W775	ERJ6GEY0R00Z	1/8W 0	1	
W776	ERJ6GEY0R00Z	1/8W 0	1	
W777	ERJ6GEY0R00Z	1/8W 0	1	
W779	ERJ6GEY0R00Z	1/8W 0	1	
W780	ERJ6GEY0R00Z	1/8W 0	1	
ZJ7501	VEE0U97	EARTH WIRE	1	
■	VEP70224A	ATAPI P.C.B.	1	(RTL)
P9801	K1KB40A00124	CONNECTOR (40P)	1	
P9802	K1MN40BA0173	CONNECTOR (40P)	1	
■	VEP76172A	FRONT JACK P.C.B.	1	(RTL)
C4803	F1H1H1010005	50V 100P	1	
C4804	F1H1H1010005	50V 100P	1	
C4805	F1H1H1020005	50V 0.001U	1	
C4806	F1H1H1020005	50V 0.001U	1	
C7601	F1J0J106A014	6.3V 10U	1	
IR7601	PNA4618M14VT	IR RECEIVER	1	
JK4801	K2HA307A0009	JACK	1	
JK4802	K1AB107A0008	JACK	1	
K7701	F1H1H1020005	50V 0.001U	1	
LB4801	DOYBR0000020	1/10W 0	1	
LB4802	DOYBR0000020	1/10W 0	1	
LB4803	DOYBR0000020	1/10W 0	1	
PP4801	K1KA12B00136	CONNECTOR (12P)	1	
R4801	DOGB750JA057	1/10W 75	1	
R4802	DOGB750JA057	1/10W 75	1	
R4803	DOGB750JA057	1/10W 75	1	
R4804	DOGB102JA057	1/10W 1K	1	
R4805	DOGB471JA057	1/10W 470	1	
R4806	DOGB471JA057	1/10W 470	1	
R7601	DOYBR0000020	1/10W 0	1	
R7602	ERDS2TJ470T	1/4W 47	1	
S7701	EVQ11G07K	SWITCH,	1	
S7704	EVQ11G07K	SWITCH,	1	
W851	DOYBR0000020	1/10W 0	1	
W852	DOYBR0000020	1/10W 0	1	
■	VEP73160B	HDMI P.C.B.	1	(RTL)
C56001	ECJ0EC1H221J	50V 220P	1	
C56103	ECJ0EB1A104K	10V 0.1U	1	
C56104	ECJ0EB1A104K	10V 0.1U	1	
C56105	ECJ0EB1A104K	10V 0.1U	1	
C56106	ECJ0EB1A104K	10V 0.1U	1	

Ref. No.	Part No.	Part Name & Description	Pcs	Remarks
C56107	ECJ0EB1A104K	10V 0.1U	1	
C56108	ECJ0EB1A104K	10V 0.1U	1	
C56109	ECJ0EB1A104K	10V 0.1U	1	
C56110	ECJ0EB1A104K	10V 0.1U	1	
C56111	ECJ0EB1A104K	10V 0.1U	1	
C56112	ECJ0EB1A104K	10V 0.1U	1	
C56113	ECJ0EB1A104K	10V 0.1U	1	
C56114	ECJ0EB1A104K	10V 0.1U	1	
C56115	ECJ0EB1A104K	10V 0.1U	1	
C56116	ECJ0EB1A104K	10V 0.1U	1	
C56117	ECJ0EB1A104K	10V 0.1U	1	
C56118	ECJ0EB1A104K	10V 0.1U	1	
C56119	ECJ0EB1A104K	10V 0.1U	1	
C56120	ECJ0EB1A104K	10V 0.1U	1	
C56121	ECJ0EB1A104K	10V 0.1U	1	
C56122	ECJ0EB1A104K	10V 0.1U	1	
C56123	ECJ0EB1A104K	10V 0.1U	1	
C56124	ECJ0EB1A104K	10V 0.1U	1	
C56125	ECJ0EB1A104K	10V 0.1U	1	
C56126	ECJ0EB1A104K	10V 0.1U	1	
C56127	ECJ1VB1A105K	10V 1U	1	
C56128	F1J1A2250011	10V 2.2U	1	
C56129	ECJ0EC1H221J	50V 220P	1	
C56130	ECJ1VB1A105K	10V 1U	1	
C56131	ECJ1VB1A105K	10V 1U	1	
C56133	ECJ1VB1A105K	10V 1U	1	
C56134	ECJ1VB1A105K	10V 1U	1	
C56135	ECJ0EB1A104K	10V 0.1U	1	
C56140	ECJ0EB1A104K	10V 0.1U	1	
D56101	MA2J72800L	DIODE	1	
FL56104	F1H0J1050025	FILTER	1	
FL56105	F1H0J1050025	FILTER	1	
FL56106	F1H0J1050025	FILTER	1	
FL56107	F1H0J1050025	FILTER	1	
FL56110	F1H0J1050025	FILTER	1	
FP56101	K1MN30AA0082	CONNECTOR (30P)	1	
IC56103	MN864702A	IC	1	
IC56104	C0CBCBC00174	IC	1	
IC56105	C0CBCDC00052	IC	1	
IC56106	C0DBGFD00024	IC	1	
IC56107	C0JBAB000604	IC	1	
JK56101	K1FA119E0004	JACK, HDMI	1	
L56101	J0MAB0000225	COIL	1	
L56102	J0MAB0000225	COIL	1	
L56103	J0MAB0000225	COIL	1	
L56104	J0MAB0000225	COIL	1	
LB56104	J0JCC0000119	COIL	1	
LB56105	J0JCC0000119	COIL	1	
LB56106	J0JCC0000119	COIL	1	
LB56107	J0JCC0000119	COIL	1	
LB56108	J0JHC0000032	COIL	1	
LB56109	J0JHC0000032	COIL	1	
LB56110	J0JHC0000032	COIL	1	
LB56111	J0JHC0000032	COIL	1	
LB56112	J0JHC0000032	COIL	1	
LB56113	J0JHC0000032	COIL	1	
LB56115	J0JHC0000032	COIL	1	
LB56116	J0JHC0000032	COIL	1	
P56104	K1KA08B00261	CONNECTOR	1	
Q56001	2SD1819A0L	TRANSISTOR	1	
Q56002	2SD1819A0L	TRANSISTOR	1	
Q56101	2SD1819A0L	TRANSISTOR	1	
Q56102	B1CFHA000002	TRANSISTOR	1	
Q56103	B1CFHA000002	TRANSISTOR	1	

Ref. No.	Part No.	Part Name & Description	Pcs	Remarks
Q56104	2SD1819A0L	TRANSISTOR	1	
Q56105	2SD1819A0L	TRANSISTOR	1	
R56001	ERJ2GEJ472X	1/16W 4.7K	1	
R56002	ERJ2GEJ473X	1/16W 47K	1	
R56003	ERJ2GEJ225X	1/16W 2200K	1	
R56004	ERJ2GEJ104X	1/16W 100K	1	
R56101	ERJ2GE0R00X	1/16W 0	1	
R56102	ERJ2GE0R00X	1/16W 0	1	
R56103	ERJ2GE0R00X	1/16W 0	1	
R56104	ERJ2GE0R00X	1/16W 0	1	
R56105	ERJ2GE0R00X	1/16W 0	1	
R56106	ERJ2GE0R00X	1/16W 0	1	
R56107	ERJ2GE0R00X	1/16W 0	1	
R56108	ERJ2GE0R00X	1/16W 0	1	
R56110	ERJ2GE0R00X	1/16W 0	1	
R56111	ERJ2GE0R00X	1/16W 0	1	
R56112	ERJ2GE0R00X	1/16W 0	1	
R56114	ERJ2GE0R00X	1/16W 0	1	
R56119	ERJ2GE0R00X	1/16W 0	1	
R56123	ERJ2GEJ511X	1/16W 510	1	
R56124	ERJ2GEJ103X	1/16W 10K	1	
R56125	ERJ2GEJ202X	1/16W 2K	1	
R56126	ERJ2GEJ202X	1/16W 2K	1	
R56127	ERJ2GEJ103X	1/16W 10K	1	
R56128	ERJ2GEJ202X	1/16W 2K	1	
R56129	ERJ2GEJ202X	1/16W 2K	1	
R56130	ERJ2GEJ273X	1/16W 27K	1	
R56131	ERJ2GEJ221X	1/16W 220	1	
R56132	ERJ2GEJ224X	1/16W 220K	1	
R56133	ERJ2GEJ104X	1/16W 100K	1	
R56135	ERJ2GEJ470X	1/16W 47	1	
R56142	ERJ2GEJ330X	1/16W 33	1	
R56143	ERJ2GEJ330X	1/16W 33	1	
R56158	ERJ2GEJ152X	1/16W 1.5K	1	
R56159	ERJ2GEJ332X	1/16W 3.3K	1	
R56160	ERJ2GEJ223X	1/16W 22K	1	
R56161	ERJ2GEJ470X	1/16W 47	1	
R56162	ERJ2GEJ103X	1/16W 10K	1	
R56163	ERJ2GEJ103X	1/16W 10K	1	
RX56101	D1H8R0040009	RESISTOR-RESISTOR	1	
RX56102	D1H8R0040009	RESISTOR-RESISTOR	1	
■	VEP73165A	DV/SD/USB P.C.B.	1	(RTL)
C38004	F1H1C104A042	16V 0.1U	1	
C38006	F1H1H1030006	50V 0.01U	1	
C38007	F1H1A225A051	10V 22U	1	
IC38002	C0DBZHE00025	IC	1	
LB38001	J0JGC0000020	COIL	1	
LB38003	J0JHC0000032	COIL	1	
LB38004	J0JHC0000045	COIL	1	
LB38005	J0JDC0000092	COIL	1	
P38001	K1KA18A00106	CONNECTOR	1	
P38002	K1NA09E00083	CONNECTOR (9P)	1	
P38003	K1FY104B0011	CONNECTOR (104P)	1	
P38004	K1MN07AA0003	CONNECTOR (7P)	1	
P38005	K1FY104B0006	CONNECTOR (4P)	1	
R38001	D0YBR0000020	1/10W 0	1	
R38004	D0GB101JA057	1/10W 100	1	
R38005	D0GB220JA057	1/10W 22	1	
R38006	D0GB220JA057	1/10W 22	1	
RX38001	EXB38V220JV	RESISTOR-RESISTOR	1	
■		CASING/ACCESSORY/PACKING		

Ref. No.	Part No.	Part Name & Description	Pcs	Remarks
1	VEP79195A	MAIN P.C.B.	1	(RTL) EB
1	VEP79195B	MAIN P.C.B.	1	(RTL) EG
1	VEP79195C	MAIN P.C.B.	1	(RTL) EC
2	VEP76172A	FRONT JACK P.C.B.	1	(RTL)
3	VEP73165A	DV/SD/USB P.C.B.	1	(RTL)
4	VEP73160B	HDMI P.C.B.	1	(RTL)
5	RFKB77123A	BACKEND P.C.B.	1	(RTL) EB
5	RFKB77123B	BACKEND P.C.B.	1	(RTL) EG
5	RFKB77123C	BACKEND P.C.B.	1	(RTL) EC
6	RFKB71134A	DIG. INTERFACE P.C.B.	1	(RTL) EB
6	RFKB71134AT	DIG. INTERFACE P.C.B.	1	(RTL) EG, EC
7	VEP72120A	FL DRIVE P.C.B.	1	(RTL)
9	RHD30113-1K	SCREW	4	(K)
9	RHD30113	SCREW	4	(S)
10	RHD30119-L	SCREW	13	
11	RKMD0006-K2	TOP CASE	1	(K) △
11	RKMD0006-S2	TOP CASE	1	(S) △
13	VEK0L28	FFC	1	
14	RMA2072	PCB ANGLE	1	
15	XSN3+4FJ	SCREW	2	
16	RHD26045	SCREW	7	
17	RHD30111-3	SCREW	23	
18	RHDC0023	SCREW	3	
19	RHD30148	SCREW	1	
20	RMA2044-2J	DVD ANGLE	1	
21	RMC0632	EARTH SPRING	1	
22	RHD26054	SCREW	1	
24	VHD1092-1	SCREW	1	
25	RYP1429A-K	FRONT PANEL ASS'Y1	1	EBK
25	RYP1429A-S	FRONT PANEL ASS'Y1	1	EBS
25	RYP1429-K	FRONT PANEL ASS'Y1	1	EGK ECK
25	RYP1429-S	FRONT PANEL ASS'Y1	1	EGS ECS
25-2	RYQ0654-S	DUB BUTTON UNIT	1	
25-3	RGU2524B-K	EJECT BUTTON	2	(K)
25-3	RGU2524-S	EJECT BUTTON	2	(S)
25-4	RGU2525B-K1	PLAY BUTTON	1	(K)
25-4	RGU2525B-S1	PLAY BUTTON	1	(S)
25-5	RYF0831A-K	DOOR ASS'Y	1	EBK
25-5	RYF0831-K	DOOR ASS'Y	1	EGK ECK
25-5	RYF0831A-S	DOOR ASS'Y	1	EBS
25-5	RYF0831-S	DOOR ASS'Y	1	EGS ECS
25-6	RKF0784B-K	TRAY DOOR	1	(K)
25-6	RKF0784B-S	TRAY DOOR	1	(S)
25-7	RKF0783D-K	BLINDER PANEL	1	(K)
25-7	RKF0783B-S	BLINDER PANEL	1	(S)
25-8	RMC0689	EARTH SPRING(T)	1	
25-9	VMB2521	BLINDER SPRING	1	
25-10	RMB0857	TRAY DOOR SPRING	1	
25-12	RDG0638	DAMPER	1	
25-13	RGU2580-K	POWER BUTTON	1	(K)
25-13	RGU2580-S	POWER BUTTON	1	(S)
25-14	VSQ1088-2	MAGNET	2	
25-15	RHD26045	SCREW	1	
26	RMZ0898	DIGITAL BARRIER	1	
27	XTV26+6FFJ	SCREW	1	
28	VWJ2003	FFC	1	
29	RGR0376B-C	REAR PANEL	1	EB △
29	RGR0376B-A	REAR PANEL	1	EG △
29	RGR0376B-B	REAR PANEL	1	EC △
30	L6FALCCH0002	FAN MOTOR	1	
31	RMZ0897	BARRIER	2	
32	RKA0196-K	RUBBER CUSHON	2	
33	RKA0137-K	FOOT RUBBER	2	
34	RMQ1612	HEAT TRANSFER SHEET	1	
35	RMQ1614	HEAT TRANSFER SHEET	1	
36	RSC0805	DIGITAL SHIELD	1	
37	RFKNEX98VEB	RAM/DIGITAL P.C.B. MODULE	1	(RTL) EB
37	RFKNEX98VEG	RAM/DIGITAL P.C.B. MODULE	1	(RTL) EG

Ref. No.	Part No.	Part Name & Description	Pcs	Remarks
37	RFKNEX98VEC	RAM/DIGITAL P.C.B. MODULE	1	(RTL) EC
38	RMX0354A-3	MECHA SPACER (F)	1	
39	RMX0355A-3	MECHA SPACER (R)	1	
40	VWJ2004	FFC	1	
41	VEP70224A	ATAPI P.C.B.	1	(RTL)
42	VEE1E58	WIRE WITH CONNECTOR	1	
43	VWJ2030	DIGITAL - HDD FFC	1	
44	RMA2123	USB ANGLE	1	
45	RMC0741	EARTH PLATE (T)	1	
46	VWJ2048	DV-DIGITAL FFC	1	
47	RFKV0131HDK	HDD 250GB	1	
48	RHD34001	SCREW	4	
49	RMA2124	HDD BRACKET	1	
50	RMG0739A-G	FLOATING RUBBER	4	
51	RMG0742-K1	HDD SHEET	4	
52	RMZ0955	CONNECTOR SHIELD	1	
101	VEG1699KIT	RDD CYLINDER ASS'Y	1	
101-1	VMD5464	FPC HOLDER	1	
102	VEM0800-1B	CAPSTAN MOTOR	1	
103	LLAG00000011	FE HEAD ASS'Y	1	
104	VDB1431	TENSION ARM BOSH	1	
105	VDG1686	INTERMEDIATE GEAR	1	
106	VDG1685-1	MAIN CAM GEAR 3	1	
107	VDG1512-1	IDLER GEAR	2	
108	VDG1514-4	CHANGE GEAR	1	
109	VDR0372A	REEL TABLE	2	
110	VDV0391-2	CAPSTAN BELT	1	
111	VEM0797A	LOADING MOTOR	1	
112	VMB3550A	CHANGING GEAR SPRING	1	
113	VMD4987	WORM SHAFT HOLDER	1	
114	VMD5466	OPENER PIECE	1	
115	VMD4253-1	LED PRISM	1	
116	VML3934	MAIN LEVER	1	
117	VML3933	PINCH CHARGE ARM	1	
118	VML3632	IDLER ARM	1	
119	VMX3092	P4 CAP	1	
120	VXA7105-3	S SHAFT HOLDER	1	
121	VXA7106-3	T SHAFT HOLDER	1	
122	LLAE00000045	AC HEAD ASS'Y	1	
122-1	VHD1066-2	SCREW	2	
122-2	VHD1185	SCREW	1	
124	VXL3107	S LOADING ARM	1	
125	VXL3108	T LOADING ARM	1	
126	VXL3335-1	PINCH ARM	1	
127	VXL3110	P5 ARM	1	
128	VXL3111-1	TENSION ARM	1	
129	VXL3252	S BRAKE ARM	1	
130	VXL3343	T BRAKE ARM 2 U	1	
130-1	VMB3548-2A	T BRAKE SPRING	1	
131	VXL3124-2	CHANGING LEVER UNIT	1	
132	VXP2133-2	CENTER CLUTH UNIT	1	
133	VXP2168	TORQUE CLUTCH	1	
134	VMA0L25	TOP PLATE	1	
135	VMD5468-1	SIDE PLATE L2	1	
136	VMD5469-1	SIDE PLATE R3	1	
137	VXA8265	CASSETTE HOLDER U	1	
138	VXL3160	MAIN SHAFT	1	
139	VDG1684	SECTOR GEAR 2	1	
141	VML3706-3	OPENER LEVER	1	
142	VHD1044-1	SCREW	1	
143	XYN3+C4FJ	SCREW	1	
144	XTN26+7JFJ	SCREW	3	
145	XTV26+5FFJ	SCREW	2	
146	XTV26+8FFJ	SCREW	2	
148	VHD1117-1	SCREW	3	
149	VMX2208	WASHER	1	
150	VMX3114	WASHER	1	
151	VMX2699	WASHER	1	
152	VMX3196	WASHER	1	

Ref. No.	Part No.	Part Name & Description	Pcs	Remarks
A1	K2KA2BA00003	AV CORD	1	
A2	K1TWACC00001	RF COAXIAL CABLE	2	
A3	N2QAYB000130	REMOTE CONTROLLER	1	EB
A3	N2QAYB000232	REMOTE CONTROLLER	1	EG
A3	N2QAYB000233	REMOTE CONTROLLER	1	EC
A3-1	100300037800	BATTERY COVER	1	
A4	K2CT3CA00004	AC CORD	1	EB △
A4	RJA0043-1C	AC CORD	1	EG, EC △
A5	RPQD0003	PAD (C)	1	
A6	RPQFD0007	ACCESSORY BOX	1	
A7	K1TWACA00001	RF CABLE	1	EB
A8	RQT9089-B	OPERATING INSTRUCTIONS	1	EB (ID) △
A8	RQT9090-L	OPERATING INSTRUCTIONS	1	EG (IA) △
A8	RQT9091-D	OPERATING INSTRUCTIONS	1	EG, EC (IB) △
A8	RQT9092-E	OPERATING INSTRUCTIONS	1	EC (IC) △
A8	RQT9093-V	OPERATING INSTRUCTIONS	1	EC (IE) △
A8	RQT9094-M	OPERATING INSTRUCTIONS	1	EC (IF) △
A9	RPFD0007-1	POLYETHYLENE BAG	1	EB
A9	RPFD0005-1	POLYETHYLENE BAG	1	EG, EC
PC1	RPG8520	PACKING CASE	1	EBK
PC1	RPG8552	PACKING CASE	1	EBS
PC1	RPG8522	PACKING CASE	1	EGK
PC1	RPG8554	PACKING CASE	1	EGS
PC1	RPG8521	PACKING CASE	1	ECK
PC1	RPG8553	PACKING CASE	1	ECS
PC2	RPN2050	CUSHION	1	
PC3	RPFD0006-1	MIRAMAT BAG	1	
PC4	RPN2052	FRONT PAD	1	
PC5	RPQ2372	PAD	1	EC