

Operating Instructions

STEREO DOUBLE CASSETTE DECK

CT-W503R
CT-W403R
CT-W203

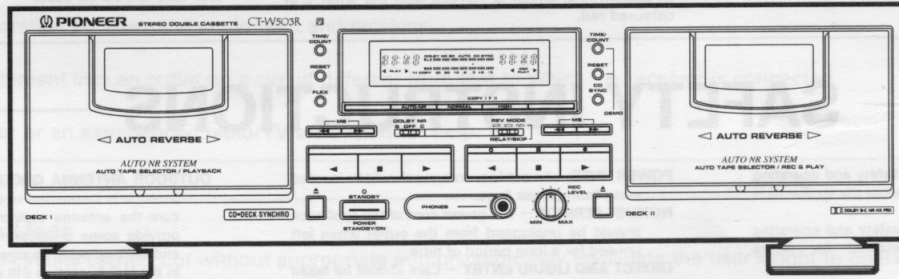

- The above illustration shows CT-W503R.
- For the demo function, refer to back cover of these operating instructions.

Thank you for buying this Pioneer product.

Please read through these operating instructions so you will know how to operate your unit properly. After you have finished reading the instructions, keep the manual in a safe place for future reference.

In some countries or regions, the shape of the power plug and power outlet may sometimes differ from that shown in the explanatory drawings. However, the method of connecting and operating the unit is the same.

WARNING: TO PREVENT FIRE OR SHOCK HAZARD, DO NOT EXPOSE THIS APPLIANCE TO RAIN OR MOISTURE.

IMPORTANT NOTICE

The serial number for this equipment is located on the rear panel. Please write this serial number on your enclosed warranty card and keep it in a secure area. This is for your security.

[For Canadian model]

CAUTION: TO PREVENT ELECTRIC SHOCK DO NOT USE THIS (POLARIZED) PLUG WITH AN EXTENSION CORD, RECEPTACLE OR OTHER OUTLET UNLESS THE BLADES CAN BE FULLY INSERTED TO PREVENT BLADE EXPOSURE.

ATTENTION: POUR PREVENIR LES CHOCS ELECTRIQUES NE PAS UTILISER CETTE FICHE POLARISEE AVEC UN PROLONGATEUR UNE PRISE DE COURANT OU UNE AUTRE SORTIE DE COURANT, SAUF SI LES LAMES PEUVENT ETRE INSEREES A FOND SANS EN LAISSER AUCUNE PARTIE A DECOUVERT.

"This product complies with the Radio Interference requirements of the EC (European Community) Directive 87/308/EEC."

IMPORTANT 1



The lightning flash with arrowhead, within an equilateral triangle, is intended to alert the user to the presence of uninsulated "dangerous voltage" within the product's enclosure that may be of sufficient magnitude to constitute a risk of electric shock to persons.

CAUTION

RISK OF ELECTRIC SHOCK
DO NOT OPEN

CAUTION:
TO PREVENT THE RISK OF ELECTRIC SHOCK, DO NOT REMOVE COVER (OR BACK). NO USER-SERVICEABLE PARTS INSIDE. REFER SERVICING TO QUALIFIED SERVICE PERSONNEL.



The exclamation point within an equilateral triangle is intended to alert the user to the presence of important operating and maintenance (servicing) instructions in the literature accompanying the appliance.

IMPORTANT 2

FOR USE IN THE UNITED KINGDOM

The wires in this mains lead are coloured in accordance with the following code:

blue neutral
brown live

If the plug provided is unsuitable for your socket outlets, the plug must be cut off and a suitable plug fitted.

The cut-off plug should be disposed of and must not be inserted into any 13 amp socket as this can result in electric shock. The plug or adaptor or the distribution panel should be provided with 5 amp fuse. As the colours of the wires in the mains lead of this appliance may not correspond with coloured markings identifying the terminals in your plug, proceed as follows:

The wire which is coloured blue must be connected to the terminal which is marked with the letter N or coloured black.

The wire which is coloured brown must be connected to the terminal which is marked with the letter L or coloured red.

Do not connect either wire to the earth terminal of a three pin plug.

NOTE

After replacing or changing a fuse, the fuse cover in the plug must be replaced with a fuse cover which corresponds to the colour of the insert in the base of the plug or the word that is embossed on the base of the plug, and the appliance must not be used without a fuse cover. If lost, replacement fuse covers can be obtained from your dealer.

Only 5 amp fuses approved by B.S.I. or A.S.T.A. to B.S. 1362 should be used.

SAFETY INSTRUCTIONS

READ INSTRUCTIONS — All the safety and operating instructions should be read before the appliance is operated.

RETAIN INSTRUCTIONS — The safety and operating instructions should be retained for future reference.

HEED WARNING — All warnings on the appliance and in the operating instructions should be adhered to.

FOLLOW INSTRUCTIONS — All operating and use instructions should be followed.

WATER AND MOISTURE — The appliance should not be used near water — for example, near a bathtub, washbowl, kitchen sink, laundry tub, in a wet basement, or near a swimming pool, etc.

LOCATION — The appliance should be installed in a stable location.

WALL OR CEILING MOUNTING — The appliance should not be mounted to a wall or ceiling.

VENTILATION — The appliance should be situated so that its location or position does not interfere with its proper ventilation. For example, the appliance should not be situated on a bed, sofa, rug, or similar surface that may block the ventilation openings; or, placed in a built-in installation, such as a bookcase or cabinet that may impede the flow of air through the ventilation openings.

HEAT — The appliance should be situated away from heat sources such as radiators, heat registers, stoves, or other appliances (including amplifiers) that produce heat.

POWER SOURCES — The appliance should be connected to a power supply only of the type described in the operating instructions or as marked on the appliance.

POWER-CORD PROTECTION — Power-supply cords should be routed so that they are not likely to be walked on or pinched by items placed upon or against them. Pay particular attention to cords at plugs, convenience receptacles, and the point where they exit from the appliance.

POLARIZATION — If your purchased product is provided with a polarized power plug, please read the following instructions. This product is equipped with a polarized alternating current line plug (a plug having one blade wider than the other). This plug will fit into the power outlet only one way. This is a safety feature. If you are unable to insert the plug fully into the outlet, try reversing the plug. If the plug should still fail to fit, contact your electrician to replace your obsolete outlet. Do not defeat the safety purpose of the polarized plug.

CLEANING — The appliance should be cleaned only with a polishing cloth or a soft dry cloth. Never clean with furniture wax, benzene, insecticides or other volatile liquids since they may corrode the cabinet.

POWER LINES — An outdoor antenna should be located away from power lines.

NONUSE PERIODS — The power cord of the appliance should be unplugged from the outlet when left unused for a long period of time.

OBJECT AND LIQUID ENTRY — Care should be taken so that objects do not fall and liquids are not spilled into the enclosure through openings.

DAMAGE REQUIRING SERVICE — The appliance should be serviced by a Pioneer authorized service center or qualified service personnel when:

- The power-supply cord or the plug has been damaged.
- Objects have fallen, or liquid has been spilled into the appliance.
- The appliance has been exposed to rain.
- The appliance does not appear to operate normally or exhibits a marked change in performance.
- The appliance has been dropped or the enclosure damaged.

SERVICING — The user should not attempt to service the appliance beyond that described in the operating instructions. All other servicing should be referred to qualified service personnel.

OUTDOOR ANTENNA GROUNDING — If an outside antenna is connected to the antenna terminal, be sure the antenna system is grounded so as to provide some protection against voltage surges and built-up static charges.

In the U.S.A. section 810 of the National Electrical Code, ANSI/NFPA 70, provides information with respect to proper grounding of the mast and supporting structure, grounding of the lead-in wire to an antenna discharge unit, size of grounding conductors, location of antenna discharge unit, connection to grounding electrodes, and requirements for the grounding electrode. See Fig. A.

CART — An appliance and cart combination should be moved with care. Quick stops, excessive force, and uneven surfaces may cause the appliance and cart combination to overturn.



NEC — NATIONAL ELECTRIC CODE

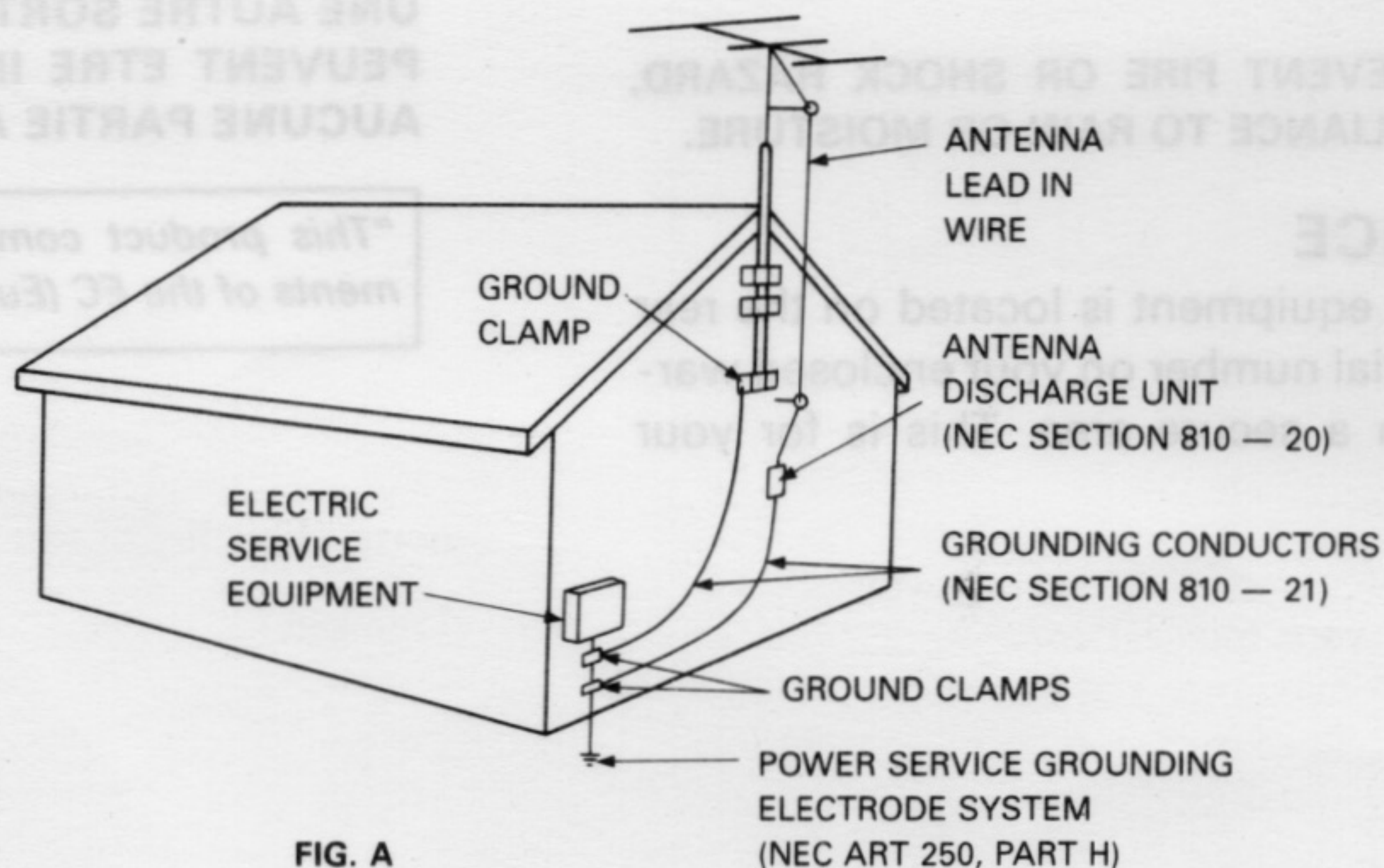

FIG. A

This equipment has been tested and found to comply with the limits for a Class B digital device, pursuant to Part 15 of the FCC Rules. These limits are designed to provide reasonable protection against harmful interference in a residential installation. This equipment generates, uses, and can radiate radio frequency energy and, if not installed and used in accordance with the instructions, may cause harmful interference to radio communications. However, there is no guarantee that interference will not occur in a particular installation. If this equipment does cause harmful interference to radio or television reception, which can be determined by turning the equipment off and on, the user is encouraged to try to correct the interference by one or more of the following measures:

- Reorient or relocate the receiving antenna.
- Increase the separation between the equipment and receiver.
- Connect the equipment into an outlet on a circuit different from that to which the receiver is connected.
- Consult the dealer or an experienced radio/TV technician for help.

Information to User

Alteration or modifications carried out without appropriate authorization may invalidate the user's right to operate the equipment.

[For Canadian model]

This digital apparatus does not exceed the Class B limits for radio noise emissions from digital apparatus set out in the Radio Interference Regulations of the Canadian Department of Communications.

[Pour le modèle Canadien]

L'interférence, radioélectrique générée par cet appareil numérique de type B ne dépasse pas les limites énoncées dans le Règlement sur les perturbations radioélectriques, section appareil numérique, du Ministère des Communications.



Dear Customer:

Selecting fine audio equipment such as the unit you've just purchased is only the start of your musical enjoyment. Now it's time to consider how you can maximize the fun and excitement your equipment offers. This manufacturer and the Electronic Industries Association's Consumer Electronics Group want you to get the most out of your equipment by playing it at a safe level. One that lets the sound come through loud and clear without annoying blaring or distortion—and, most importantly, without affecting your sensitive hearing.

Sound can be deceiving. Over time your hearing "comfort level" adapts to higher volumes of sound. So what sounds "normal" can actually be loud and harmful to your hearing. Guard against this by setting your equipment at a safe level **BEFORE** your hearing adapts.

To establish a safe level:

- Start your volume control at a low setting.
- Slowly increase the sound until you can hear it comfortably and clearly, and without distortion.

Once you have established a comfortable sound level:

- Set the dial and leave it there.

Taking a minute to do this now will help to prevent hearing damage or loss in the future. After all, we want you listening for a lifetime.

We Want You Listening For A Lifetime

Used wisely, your new sound equipment will provide a lifetime of fun and enjoyment. Since hearing damage from loud noise is often undetectable until it is too late, this manufacturer and the Electronic Industries Association's Consumer Electronics Group recommend you avoid prolonged exposure to excessive noise. This list of sound levels is included for your protection.

Decibel Level Example

Decibel Level	Example
30	Quiet library, soft whispers
40	Living room, refrigerator, bedroom away from traffic
50	Light traffic, normal conversation, quiet office
60	Air conditioner at 20 feet, sewing machine
70	Vacuum cleaner, hair dryer, noisy restaurant
80	Average city traffic, garbage disposals, alarm clock at two feet.

THE FOLLOWING NOISES CAN BE DANGEROUS UNDER CONSTANT EXPOSURE

90	Subway, motorcycle, truck traffic, lawn mower
100	Garbage truck, chain saw, pneumatic drill
120	Rock band concert in front of speakers, thunderclap
140	Gunshot blast, jet plane
180	Rocket launching pad

Information courtesy of the Deafness Research Foundation.



CONTENTS

INSTALLATION.....	4
MAINTENANCE.....	4
HANDLING CASSETTE TAPES.....	5
CONNECTIONS.....	6
FRONT PANEL FACILITIES.....	7
PLAYBACK.....	11
SINGLE PLAYBACK.....	11
BLANK SKIP.....	11
RELAY PLAYBACK.....	11
MUSIC SEARCH.....	12
RECORDING.....	13
RECORDING.....	13
RECORDING MUTE.....	13
ERASING A TAPE.....	13
CD · DECK SYNCHRO RECORDING.....	14
TAPE COPYING.....	15
TROUBLESHOOTING.....	16
SPECIFICATIONS.....	18

INSTALLATION

When installing the deck, avoid locations with high temperatures or humidity, and make sure that the deck receives adequate ventilation.

- Do not install the deck in locations subject to direct sunlight, or near a space heater or other heating device, as this may cause damage to the finish or internal parts.
- Malfunctions may also result if the deck is installed in an excessively humid or dusty location. Avoid installing the deck next to kitchen counters or other locations subject to oily smoke or humidity.
- If the deck is placed directly on top of an amplifier, it may pick up humming or other noise. Also, if the amplifier generates a large amount of heat, the deck may malfunction.
- If the deck is located near a television set, it may pick up interference noise, which will be recorded as a whistling sound on the tape. If this happens, move the deck further away from the television set or turn the television set off when operating the deck.
- Do not place a cloth over the deck, or block the ventilation slots in any way. The ventilation slots on this deck are necessary to keep internal parts cool. If they are blocked, the deck may malfunction.

CONDENSATION

When the deck is moved from a cold location to a warm location, or when the temperature of the room changes suddenly, condensation may form on the mechanical parts. This can adversely affect the performance of the deck. If this occurs, wait for about one hour to allow the deck to adjust to the room temperature. To prevent condensation when heating a room, raise the temperature slowly.

THE POWER SWITCH IS SECONDARY CONNECTED AND THEREFORE DOES NOT SEPARATE THE UNIT FROM MAINS POWER IN STANDBY POSITION.

MAINTENANCE

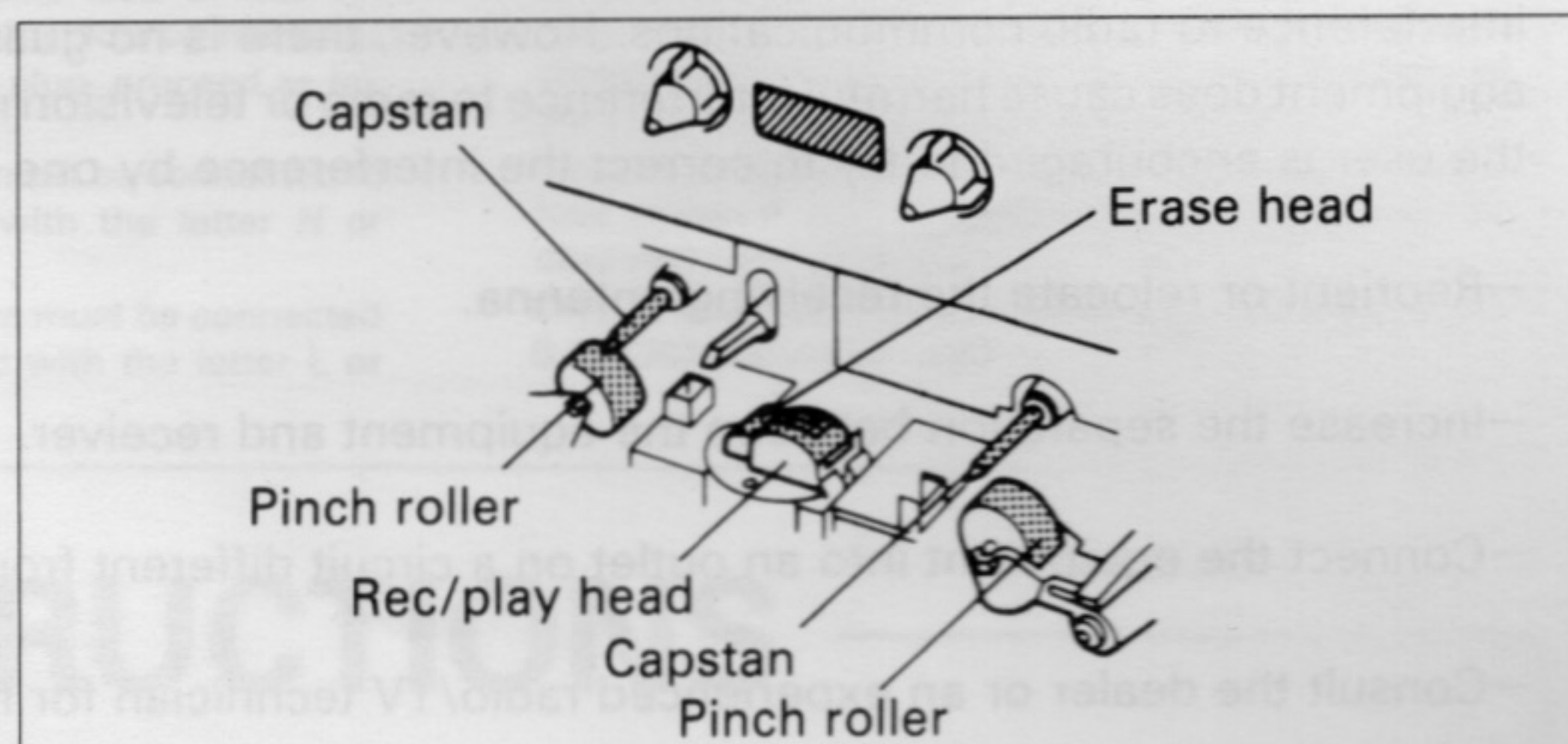

CLEANING THE HEADS, PINCH ROLLERS AND CAPSTANS

The heads, pinch rollers and capstans are likely to get dirty quite easily. If these parts, particularly the heads, get dirty, the high frequency components of a recording will not be reproduced and the stereo balance will be impaired, resulting in a deterioration of the playback sound. It is therefore recommended that the head section be cleaned regularly.

1. Set the POWER switch to STANDBY.
2. Press the eject button to open the cassette door.
3. Dip a cleaning swab in cleaning fluid and use it to wipe the heads, capstans and pinch rollers.

NOTE:

After cleaning the head section, do not load a tape until the cleaning fluid has dried completely (about two or three minutes).

DEMAGNETIZING THE HEADS

After using the cassette deck for a period of time, the heads will become magnetized. The same effect will occur if a magnetized screwdriver, magnet or other magnetized object is brought too close to the heads. When the heads become magnetized, high-frequency sounds will be lost during recording or playback, and interference noise may also occur. The heads should be regularly demagnetized with a head demagnetizer, which can be purchased at most audio stores.

When demagnetizing the heads, make sure that the POWER switch of the cassette deck is set to ON. However, be sure to turn down the amplifier's volume control to its lower position, and disconnect any headphones from their headphones jack. For detailed instructions, refer to the operating instructions of the head demagnetizer.

CLEANING THE FRONT PANEL

Clean the deck regularly with a soft cloth. If the front panel becomes soiled, moisten a soft cloth with a weak solution of neutral detergent (diluted in five to six parts water), wring the cloth well, and wipe the panel clean. Never use volatile cleaners like thinners, benzene or alcohol because they will damage the panel finish.

HANDLING CASSETTE TAPES

CONNECTIONS

A Turn pencil to remove tape slack

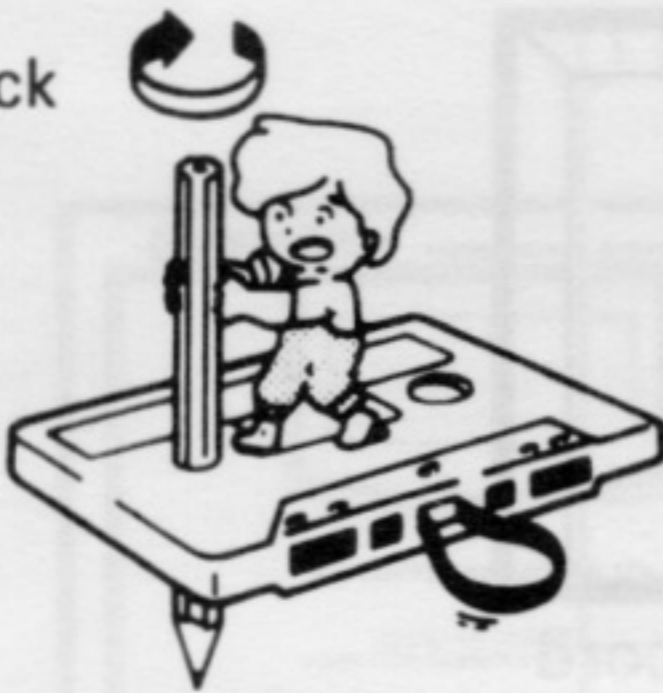

B For erasure prevention remove

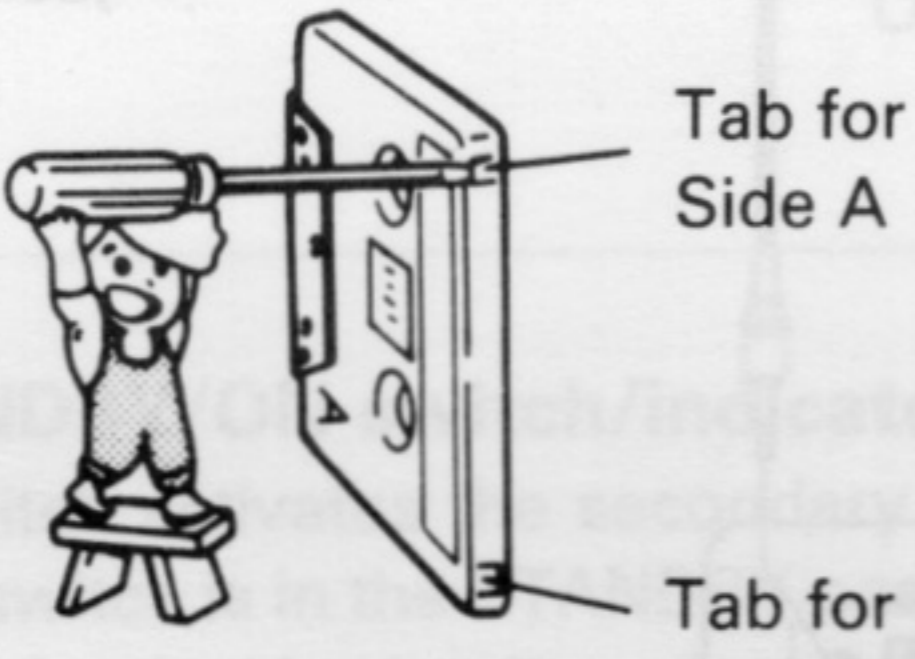

Tab for Side A

Tab for Side B

C Cover with adhesive tape



D Erasure prevention tabs

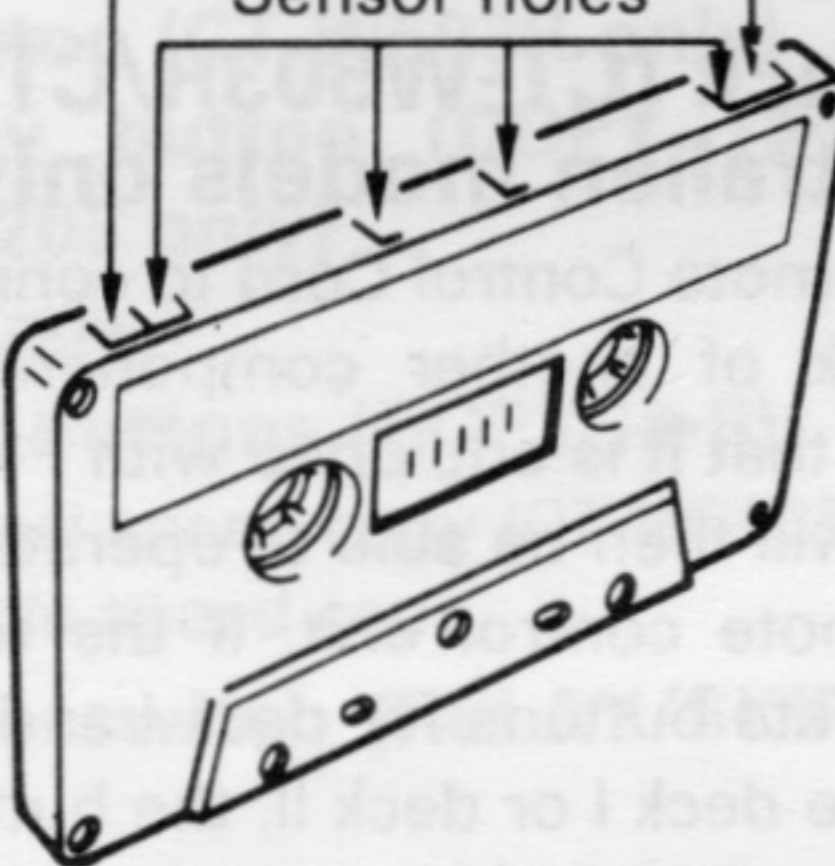

Sensor holes

TYPE IV (Metal) tape

E Sensor holes

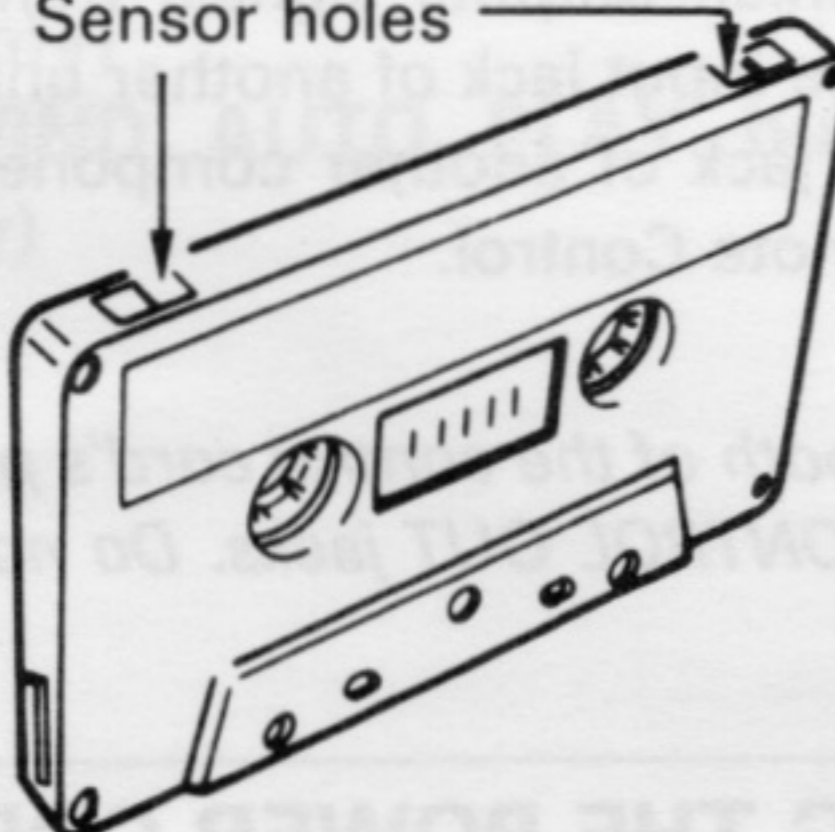

Sensor holes

TYPE II (High/CrO₂) tape

CHECK CASSETTE BEFORE USE

Check the following items before loading a cassette tape:

Is the tape loose, or is some of the tape outside the cassette?

If some of the tape is loose or projecting outside the cassette shell, the tape may not properly enter between the capstan and pinch roller. This will prevent the tape from being loaded properly, and may even damage the tape itself. In such cases, insert a pencil into the reel hole and take up the slack (Fig. A).

Some cassette tapes come with a plastic or thick paper stopper to prevent the tape from becoming slack. Remove this stopper when loading the cassette and replace it after using the cassette.

Are the accidental erasure prevention tabs intact?

These tabs allow you to prevent important recordings from being erased accidentally. When the tab on the cassette shell is broken off (Fig. B), it is not possible to activate the recording function, so valuable recordings will not be erased by mistake.

To rerecord on a cassette whose tab has been broken off, simply stick a piece of doubled adhesive tape over the hole (Fig. C).

When using TYPE IV (Metal) or TYPE II (High/CrO₂) tapes, be careful not to block the sensor holes with the tape (Fig. D, Fig. E). If the holes are blocked, the automatic tape selector mechanism will not operate correctly.

NOTES:

- The accidental erasure prevention tab for each side is the one located on the top left when the side that you want to protect is facing you.
- When breaking off the tab, do not use a magnetized screwdriver.

AUTOMATIC TAPE SELECTOR FUNCTION

This cassette deck is equipped with an automatic tape selector function which utilizes the sensor holes on the tape cassette to determine the type of tape being used. The deck is then set to match the tape recording bias and equalization.

NOTES:

- When using TYPE IV (Metal) tapes, make sure that the tapes have sensor holes.
- Make sure that the sensor holes on the cassette are not blocked; otherwise the tape selector mechanism will not function properly.
- Do not use TYPE III (FeCr) tapes.

TIPS ON CASSETTE TAPES

- Leader tape (which cannot be recorded on) is provided at the beginning of a cassette tape. Let the tape run for about 5 seconds before starting to record, to allow the leader tape to clear the recording head.
- Do not leave a cassette tape exposed to the environment. Store the cassette in its case after use so that dust and dirt do not adhere to the tape, and so the tape will not get slack. Store tapes in a location free from magnetism, dust, dirt, oil, heat and humidity.
- Because C-120 tapes are very thin, they can easily jam in the pinch rollers and capstan, and they often are subject to other problems such as irregular winding. It is best not to use them with this deck.
- If cassette tapes are irregularly wound, the tape may get jammed in the rollers. This can cause damage to both the tape and the deck. If you are not certain whether the tape is wound evenly, fast forward or rewind the tape from beginning to end, to make sure that the tape is properly wound.

CONNECTIONS

• This illustration shows CT-W503R.

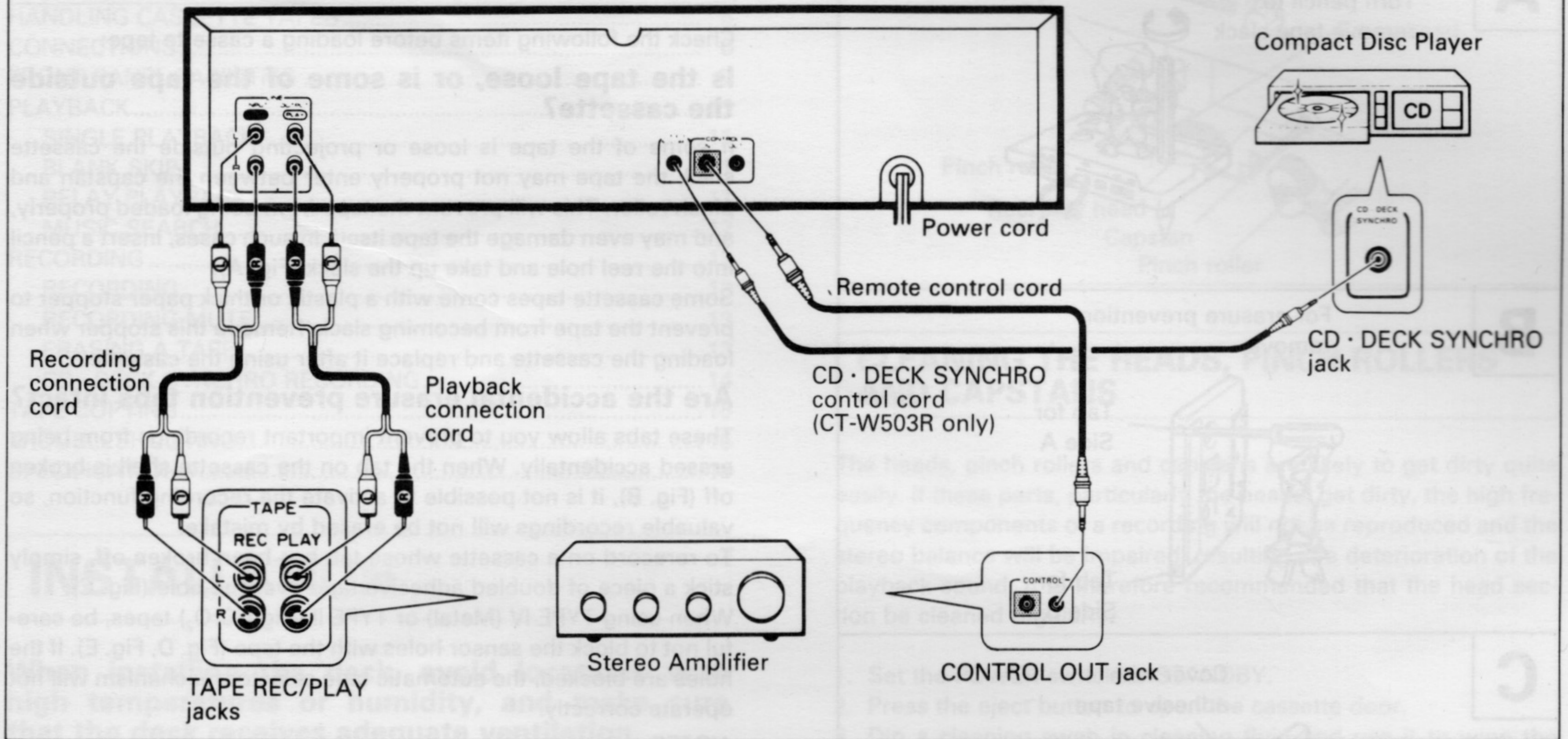

- Read through the operating instructions of the stereo components which you intend to connect to this unit.
- Turn the power on only after making all of the connections.
- Make sure that all of the connection plugs are inserted securely, as improper connections may generate noise.

NOTES:

- Keep the input and output jacks connected between the amplifier and this unit, otherwise, CD-DECK SYNCHRO recording cannot be carried out.
- Even when the CD player is connected to the amplifier with an optical fiber cable, connect the CD player to the amplifier or this unit with the input and output cords that have pin plugs.

CONNECTING THE RECORDING AND PLAYBACK CORDS

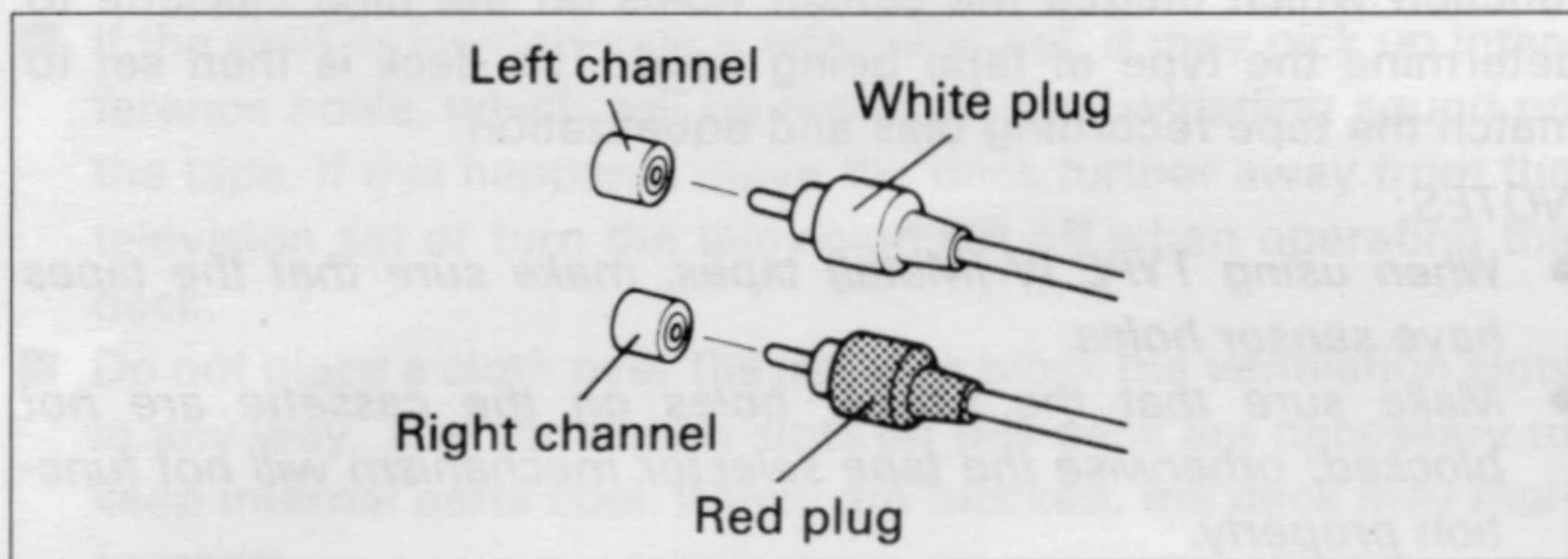

Connect the TAPE jacks of your amplifier to the LINE jacks of the cassette deck. Be sure to connect the REC (INPUT) jacks of the deck to the recording (output) jacks of the amplifier, and the PLAY (OUTPUT) jacks of the deck to the play (input) jacks of the amplifier.

- Connect the plugs properly:
Left channel — White plug
Right channel — Red plug

PIONEER SYSTEM REMOTE CONTROL

CONTROL IN jack (CT-W503R/CT-W403R/CT-W203: Australian models only)

Use the enclosed Remote Control Cord to connect this jack to the CONTROL OUT jack of another component which bears the **SR** mark (indicating that it is equipped with PIONEER System Remote Control). You will then be able to operate this unit using the Pioneer system remote control unit. If the remote control unit does not have separate buttons for deck I and deck II, or a selection button to choose deck I or deck II, the buttons will only operate deck II. To operate deck I with a remote control unit which was not designed for double deck cassette decks, see page 8.

CONTROL OUT jack

Intermediary jack which outputs signals from the CONTROL IN jack of this unit to the input jack of another unit. Connect this jack to the CONTROL IN jack of another component compatible with Pioneer System Remote Control.

NOTE:

Be sure to connect both of the control cord's plugs securely to the CONTROL IN and CONTROL OUT jacks. Do not connect only one end of the cable.

CONNECTING THE POWER CORD

Insert the power cord of the cassette deck into the accessory AC outlet of your amplifier, or into a normal household outlet.

CD-DECK SYNCHRO RECORDING (CT-W503R only)

- CD-DECK SYNCHRO recording can be carried out when this unit is connected to a Pioneer CD player equipped with a CD-DECK SYNCHRO jack.

Connection

Connect the CD-DECK SYNCHRO jack of this unit to the CD-DECK SYNCHRO jack of the CD player using the supplied CD-DECK SYNCHRO control cord.

FRONT PANEL FACILITIES

The illustration shows model CT-W503R.

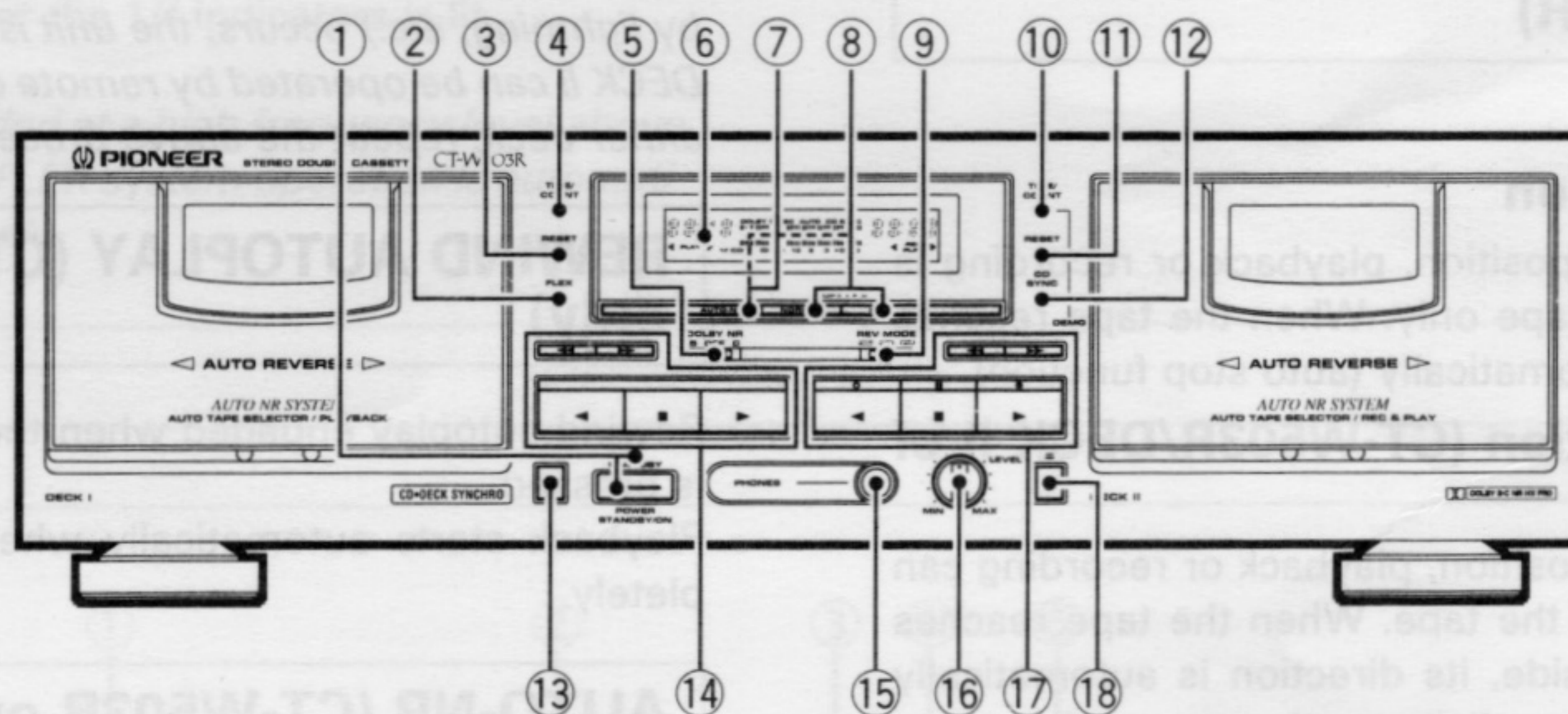

① POWER STANDBY/ON switch/indicator

The POWER switch activates the secondary transformer only. Even when the switch is in the STANDBY position, there will be a power flow to the deck's circuits as long as the power cord is connected to a power outlet.

② FLEX button (CT-W503R only)

②' Deck I REWIND AUTO PLAY button (CT-W403R/CT-W203 only)

③ DECK I counter reset button (RESET)

④ DECK I counter mode button (TIME/COUNT)

⑤ DOLBY* NR switch (B/OFF/C)

*

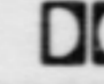
- Dolby noise reduction and HX Pro headroom extension manufactured under license from Dolby Laboratories Licensing Corporation. HX Pro originated by Bang & Olufsen.
- "DOLBY", the double-D symbol  and "HX PRO" are trademarks of Dolby Laboratories Licensing Corporation.

⑥ Function display

⑦ AUTO-NR button (CT-W503R only)

Synchro copy button (COPY I▶II/NORMAL) (CT-W403R/CT-W203 only)

Normal speed Copy.

⑧ Synchro copy buttons (COPY I▶II)

NORMAL : Normal speed copy (CT-W503R only)

HIGH : Double speed copy

⑨ Reverse mode switch (RELAY/SKIP) (CT-W503R/CT-W403R only)

⑨' RELAY/SKIP ON/OFF switch (CT-W203R only)

⑩ DECK II counter mode button (TIME/COUNT)

⑪ DECK II counter reset button (RESET)

⑫ CD-DECK SYNCHRO recording button (CD SYNC) (CT-W503R only)

⑫' Deck II REWIND AUTO PLAY button (CT-W403R/CT-W203 only)

⑬ DECK I eject button (▲)

- If the tape is moving (playback, tape winding, etc.), press the stop (■) button before pressing this button.

NOTE:

If the power is turned off while the tape is moving, the cassette door may remain locked. In this case, turn the power on before pressing the eject (▲) button.

⑭ DECK I operation buttons

◀ : Reverse playback (CT-W503R only)

DEMO : To operate for the DEMO mode (CT-W403R only)

▶ : Forward playback

◀◀/MS : Fast reverse/music search

■ : Stop

▶▶/MS : Fast forward/music search

⑮ Headphones jack (PHONES) (CT-W503R only)

⑯ Recording level control (REC LEVEL)

⑰ DECK II operation buttons

◀ : Reverse playback (CT-W503R/CT-W403R)

▶ : Forward playback

◀◀/MS : Fast reverse/music search

■ : Stop

▶▶/MS : Fast forward/music search

○ : Recording mute

|| : Pause

● : Recording

⑱ DECK II eject button (▲)

- If the tape is moving (recording, playback, tape winding, etc.), press the stop (■) button before pressing this button.

NOTE:

If the power is turned off while the tape is moving, the cassette door may remain locked. In this case, turn the power on before pressing the eject (▲) button.

FRONT PANEL FACILITIES

REVERSE MODE SWITCH (REV MODE) (CT-W503R/CT-W403R)

There are three settings:

One way mode \Rightarrow position

When the switch is set to this position, playback or recording is performed on one side of the tape only. When the tape reaches the end of the side, it stops automatically (auto stop function).

Two way mode \Rightarrow position (CT-W503R/DECK II of CT-W403R only)

When the switch is set to this position, playback or recording can be performed on both sides of the tape. When the tape reaches the end of the first (forward) side, its direction is automatically reversed, and playback or recording continues on the other (reverse) side. When it reaches the end of the reverse side, the tape stops automatically (auto stop function). If playback or recording is started from the reverse side, the tape will stop when it reaches the end of that side.

Repeat mode \Rightarrow position (RELAY/SKIP) (CT-W503R/DECK II of CT-W403R only)

When the switch is set to this position for playback, both sides of the tape are played back repeatedly until the stop (■) button is pressed, or until the tape has been played completely 15 times (16 sides). If the pause button is pressed to pause the tape, and then playback is restarted, the repeat mode starts over from the beginning, and will play the tape 15 times (sixteen sides).

When the switch is set to this position for recording, both sides are recorded and then the tape stops, as described above for the two way mode.

[DECK I of CT-W403R]

When playback continued until the end of the tape, the rewind auto play mode is engaged. The tape will then be automatically rewound and played back again until the end of the tape. The rewind auto play mode will continue to repeat this function 16 times until the stop (■) button is pressed.

Note for CT-W503R/CT-W403R

If Deck I and II are loaded with tapes, each tape will be played using relay playback.

REPEAT PLAYBACK (RELAY/SKIP) (CT-W203)

If Deck I and II are loaded with tapes, each tape will be played using relay playback.

OPERATION OF DECK I WITH A REMOTE CONTROL UNIT NOT DESIGNED FOR DOUBLE DECKS (System remote control)

Selecting DECK I

In order to operate DECK I with the remote control unit, adjust the unit as follows: With the power off, press and hold the stop (■) button of DECK I, and turn the power on. Continue to hold the stop (■) button for approximately five seconds. DECK I can now be operated using the remote control unit, but DECK II cannot.

Switching to DECK II

To restore remote control operation to DECK II, press the stop (■) button of DECK II while DECK II is in stop mode. DECK II can now be operated using the remote control unit. Remote control operation can be switched back and forth between decks by pressing the stop button of the desired DECK while it is in stop mode.

NOTE:

If a power failure or a sudden change in the power supply (caused by lightning, etc.) occurs, the unit is reset to its original state. Only DECK II can be operated by remote control. To restore operation to either deck, repeat the above procedure from the beginning.

REWIND AUTOPLAY (CT-W403R/CT-W203 only)

Rewind autoplay engaged when the REWIND AUTO PLAY button is pressed.

Playback starts automatically when the tape is rewound completely.

AUTO-NR (CT-W503R only)

Use AUTO NR for playback. This NR system is useful in these situations: when the type of Dolby NR system (B/C) used during the recording of a tape is not clear; when there is a hissing noise during playback of a tape which was not recorded using the Dolby system; when the Dolby NR for the A and B sides of a tape is different; or when the Dolby NR for the DECK I and II is different. When the AUTO NR is turned on the "AUTO" indicator lights up and both the "B" and "C" indicators turn off.

AUTO-NR system uses the following methods:

- This system automatically switches to the most appropriate Dolby NR system using Pioneer's sound quality evaluation standard.
- When this system selects the Dolby NR OFF position, the Pioneer Proprietary Noise Reduction System works automatically.
- When there is an unrecorded section of tape, the Dolby C-type NR which has maximum noise reduction is automatically selected.

NOTE:

- The quality of some prerecorded tapes may prevent the AUTO NR system from being used fully.
- During playback, use both the AUTO NR system and the FLEX system for better sound reproduction.

FLEX (1/f) SYSTEM (CT-W503R only)

- FLEX System: Frequency Level Expander System
This system automatically compensates high and low frequency level balance above 1 kHz according to the 1/f curve during playback.
Generally, envelope line of sound energy distribution of Hi-Fi sounds corresponds statistically with the 1/f curve.
The 1/f curve indicates that if the frequency doubles, the level decreases by approx. half of the original frequency level.
- During playback, the FLEX system automatically compensates tapes with poor sound quality at high frequency levels of 1 kHz and over, based on the appropriate auditory characteristics.
The FLEX system is designed to improve high frequency reproduction in the 10 kHz range by up to about 12 dB (max), particularly in tapes with poor sound clarity and sound presence at high frequency levels. If the playback tape sound matches the 1/f curve, the FLEX system defeats compensation adjustment automatically.
- When you press the FLEX button to turn the FLEX system on and start playback, the 1/f indicator flash and compensation adjustment begins.
Compensation adjustment takes within approximately 3 seconds to complete, depending on the music source. The indicator change from a flashing to a steadily lit condition.

- When the FLEX system is engaged, each music selection is automatically adjusted during playback. System operation status is indicated by whether the 1/f indicator is lit.

NOTE:

- When a tape has been recorded at a high frequency level above the compensation level, the FLEX system operation is automatically defeated during playback.

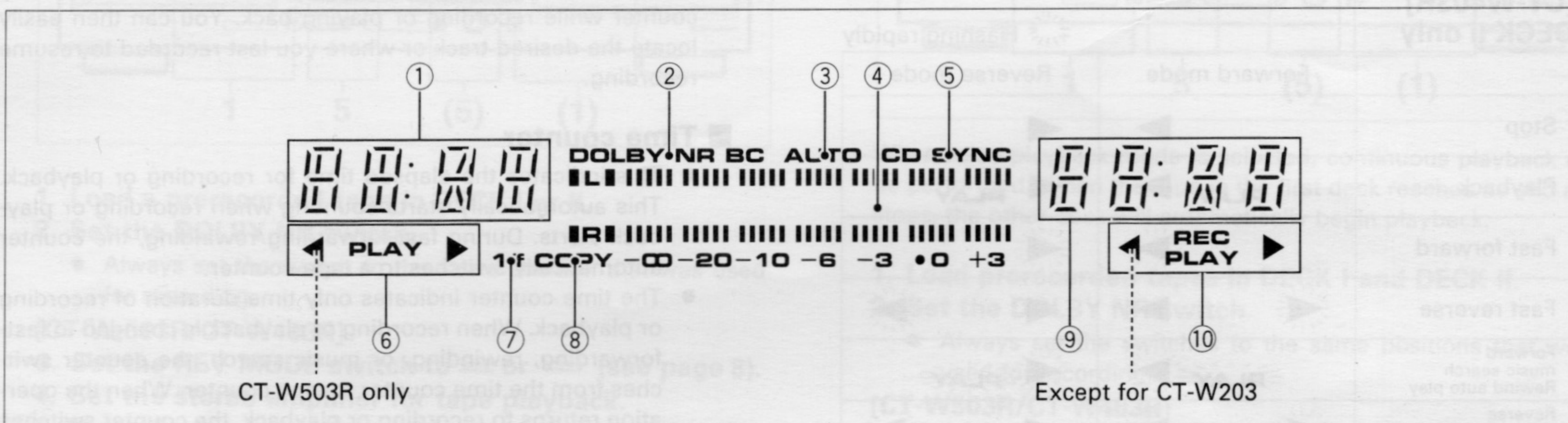
FUNCTION DISPLAY**① DECK I counter indicator**

Normally the tape counter or time counter is displayed (see page 10). It flashes for 4 seconds after the power cord is connected to the power supply.

② DOLBY NR B/C indicator**③ AUTO indicator (CT-W503R only)**

This indicator lights steadily when the AUTO-NR button is pressed.

④ Level meter

Holds peak for about 1.3 seconds.

The "●" mark beside the 0 dB mark indicates the Dolby NR systems standard level.

⑤ CD DECK SYNCHRO indicator (CD SYNC) (CT-W503R only)

This indicator lights steadily when the CD SYNC button is pressed and the operation starts.

⑥ DECK I tape transport mode indicators

- See page 10.

⑦ FLEX (1/f) indicator (CT-W503R only)

This indicator lights when the FLEX button is pressed.

⑧ Synchro copy indicator (COPY)

Indicator lights steadily: Copying at normal speed.

Indicator flashes: Copying at twice normal speed.

⑨ DECK II counter indicator

Normally the tape counter or time counter is displayed (see page 10). It flashes for 4 seconds after the power cord is connected to the power supply.

⑩ DECK II TIME counter mode indicators

- See page 10.

DOLBY NR & DOLBY HX PRO**■ Dolby NR Systems**

Dolby NR systems are designed to reduce the amount of tape hiss, mainly in the treble components. During recording, the high-pitched pianissimo sounds which are most characteristic of audible noise are boosted, and during playback, only these boosted sections are attenuated, so that tape sound is returned to normal. As a result, the noise is attenuated by an amount equal to the boosting in the treble range. The Dolby B-type NR system reduces noise in the treble range, cutting tape hiss and expanding the dynamic range. The Dolby C-type NR system is even more effective in reducing noise, as it reduces noise from the mid-range on.

NOTE:

When a tape has been recorded using the Dolby B-type or C-type NR system, make sure that the DOLBY NR switch is set to the same position during playback.

■ Dolby HX PRO Headroom Extension System

The DOLBY HX PRO system controls the bias current during recording and maintains it at the optimal level based on the amount of the high-frequency components in the music signal. It therefore provides excellent recording quality even when recording signals from digital sources, which contain a large amount of high-frequency components. To guarantee optimal results, the HX PRO system is activated automatically when recording begins. Since this system controls the quality of recording itself, the clarity of the sound will be maintained even when the tapes are played back on another cassette deck which does not contain the HX PRO Headroom Extension System.













FRONT PANEL FACILITIES

TAPE TRANSPORTATION MODE INDICATORS

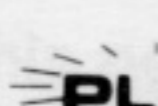
These indicators display the current tape transport mode. The chart below shows the meaning of each of these indicators. The indicators for DECK I and DECK II differ only in the location of the PLAY and REC indicators (DECK I-left, DECK II-right).

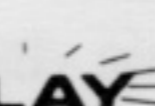





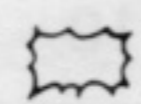

[CT-W503R] For both DECK I and II [CT-W403R] DECK II only

 Flashing rapidly

	Forward mode	Reverse mode
Stop		
Playback	PLAY 	 PLAY
Fast forward		
Fast reverse	 	 
Forward music search Rewind auto play	 PLAY 	 PLAY 
Reverse music search Rewind auto play	 PLAY 	 PLAY 

[CT-W503R/CT-W403R] DECK II only

 Flashing slowly

	Forward mode	Reverse mode
Playback pause	PLAY 	 PLAY
Recording	REC 	 REC
Recording standby	REC 	 REC
Recording mute	 REC	 REC



[CT-W403R] DECK I only [CT-W203] For both DECK I and II

 Flashing rapidly

	Forward mode
Stop	
Playback	PLAY
Fast forward	
Forward music search Rewind auto play	 PLAY

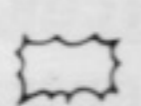
[CT-W203] DECK II only

 Flashing slowly

	Forward mode
Playback pause	 PLAY
Recording	REC PLAY
Recording standby	REC  PLAY
Recording mute	 REC PLAY

TWO MODES COUNTER

Counter Mode button (TIME/COUNT)

Press the button, and 2 modes change alternately.
Tape counter \rightleftharpoons Time counter

■ Tape counter

Different counters are provided for DECK I and II. The number of a counter increases/decreases as a tape runs. It is convenient if you make a note of the recorded content and range of the counter while recording or playing back. You can then easily locate the desired track or where you last recorded to resume recording.

■ Time counter

- This indicates the elapsed time for recording or playback. This automatically starts counting when recording or playback starts. During fast-forwarding/rewinding, the counter automatically switches to a tape counter.
- The time counter indicates only time duration of recording or playback. When recording or playback is changed to fast-forwarding, rewinding, or music search, the counter switches from the time counter to tape counter. When the operation returns to recording or playback, the counter switches to the time counter.
- Tape counter indication

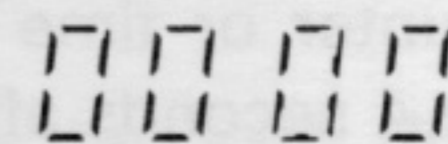

- Time counter indication

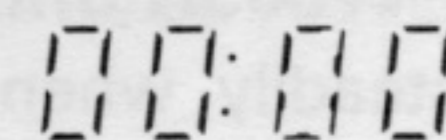

Counter reset button (RESET)

Press this button to reset the tape counter to 00 00, or to reset the time counter to 00:00.

Counter indicator during music search

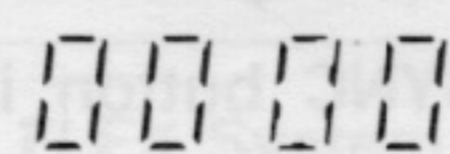

Normal tape counter indicator



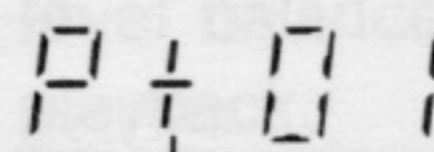

Plus sign

Counter indicator during music search

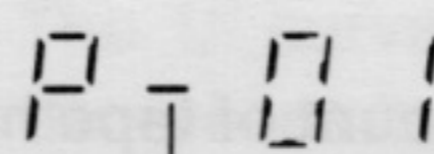

Minus sign

- A plus sign (+) appears during music search in the forward direction.
- A minus sign (-) appears during music search in the reverse direction.

The last two digits of the counter indicator show the number of selections to be skipped. If three selections are to be skipped, for example, it shows "P+03" initially. The number then decreases by 1 each time a selection is skipped ("P+02" → "P+01" etc.). When the deck resumes playback, the normal tape counter reappears.

PLAYBACK

PLAYBACK

SINGLE PLAYBACK (Either DECK I or DECK II)

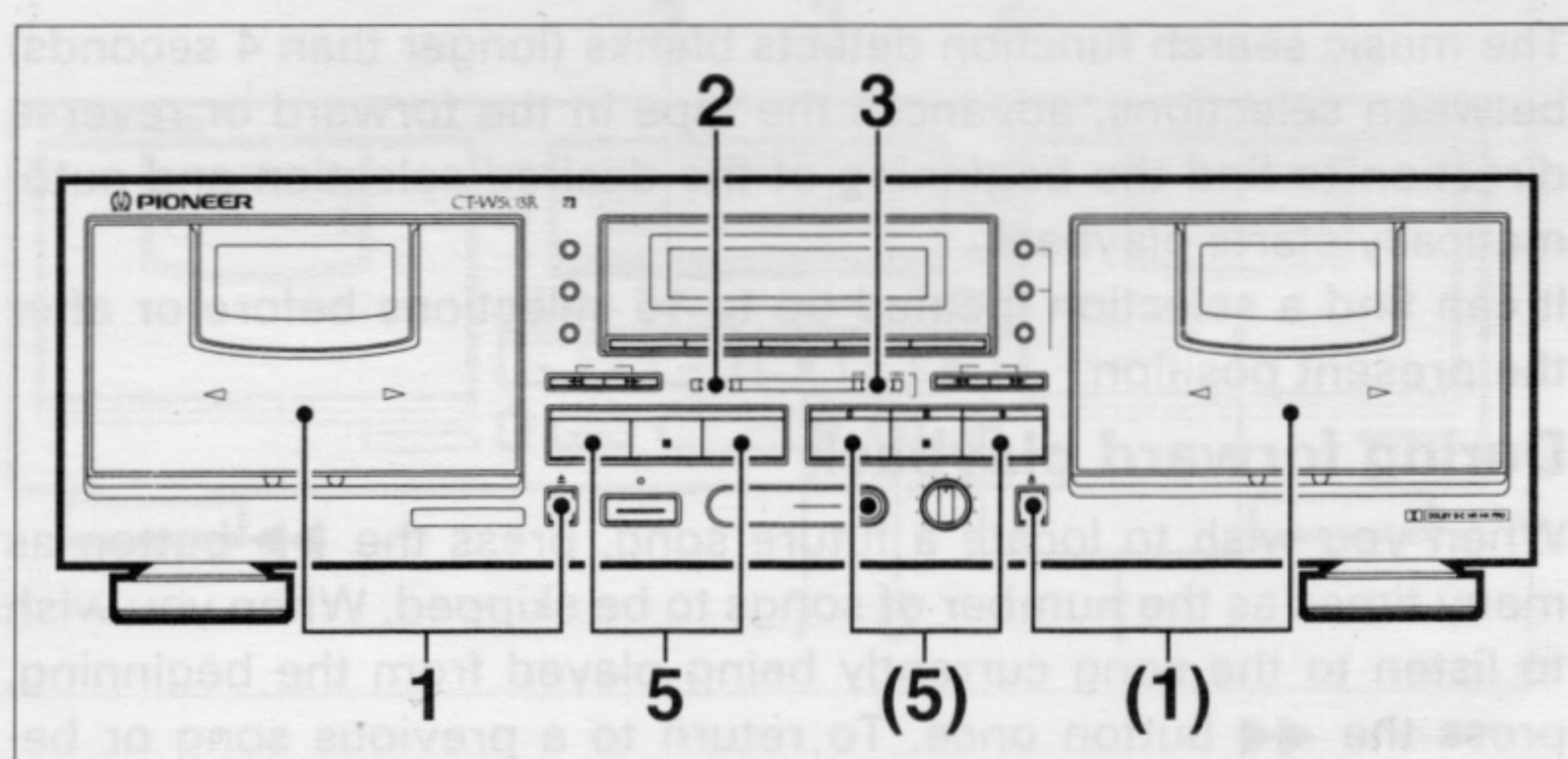

1. Load a prerecorded tape in DECK I or II.
2. Set the DOLBY NR switch.

- Always set the switch to the same position that was used for recording.

[CT-W-503R/CT-W403R]

3. Set the REV MODE switch to or (see page 8).
4. Set the stereo amplifier for tape playback.
5. Press the playback (▶ or ◀) button of either DECK I or II.

[CT-W503R only]

To improve high frequency sound during playback in tapes with poor recordings

Press the FLEX button and playback the tape.

Turn the AUTO NR system on before playing back tapes for convenience

When the type of Dolby NR system (B/C) used during recording of a tape is not clear, or if the Dolby NR system was not used during recording, please turn the AUTO NR on. The AUTO NR will select the most appropriate Dolby NR system automatically (see page 8).

To stop playback temporarily (DECK II only)

Press the pause (||) button.

- To resume playback, either press the pause (||) button again, or press the playback (▶ or ◀) button.

To stop playback

Press the stop (■) button.

BLANK SKIP

CT-W503R/CT-W403R

CT-W203

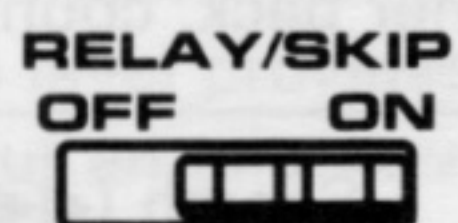
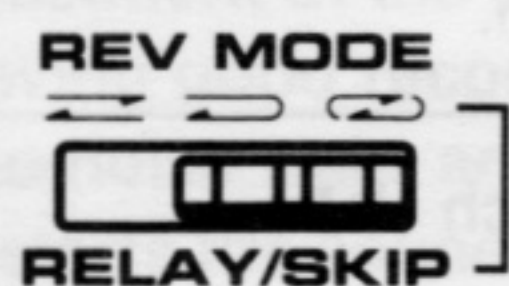

This function allows you to skip unrecorded portions of the tape during playback.

[CT-W503R/CT-W403R]

Set the REV MODE switch to .

NOTE:

- When the REV MODE switch is set to position, relay mode will be selected.

[CT-W203]

Set the RELAY/SKIP ON/OFF switch to ON.

- When this mode is selected, if the tape deck encounters an unrecorded portion of tape more than 15 seconds in length, it will fast forward the tape until it encounters another recorded portion, and resume playback from that point.

RELAY PLAYBACK

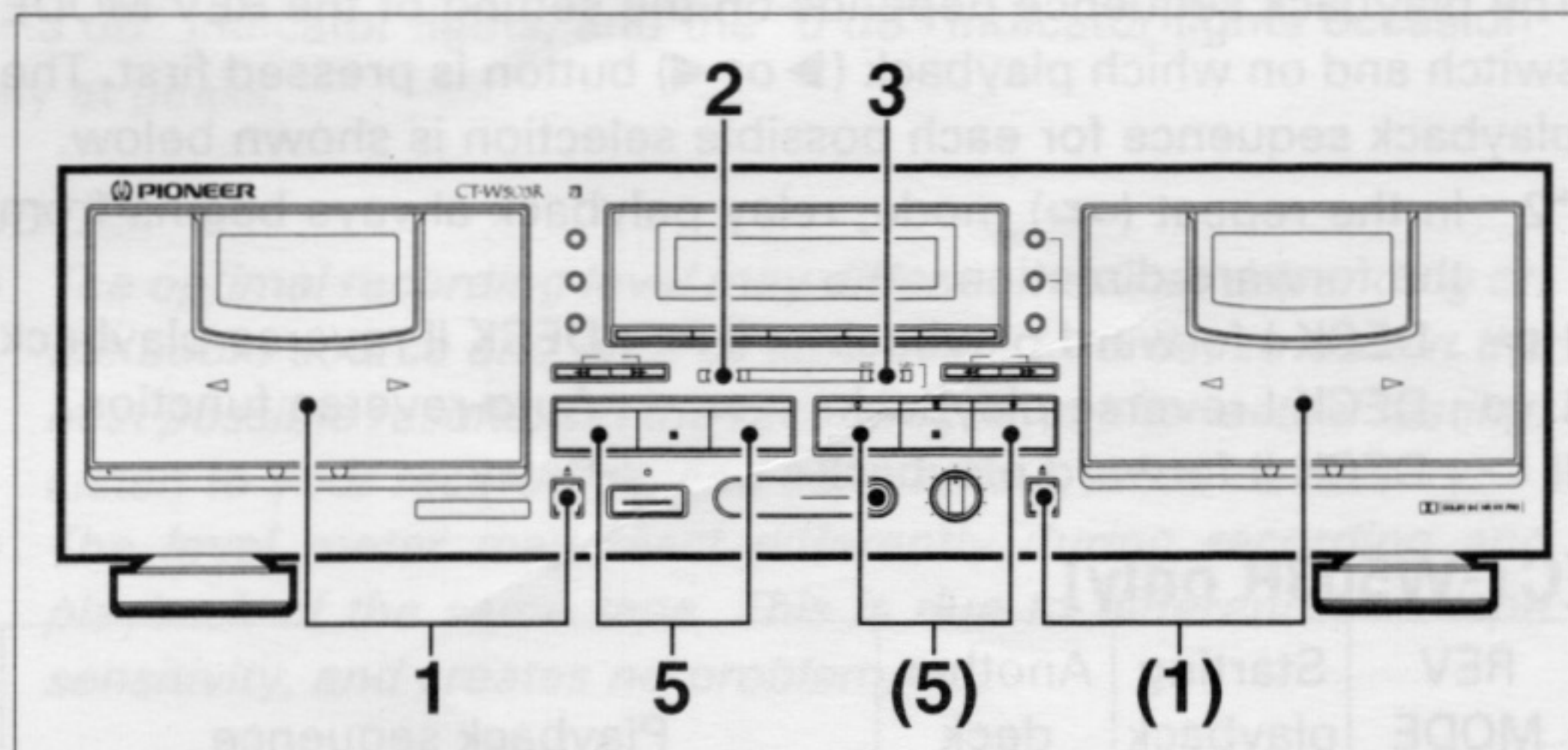

When relay playback mode is selected, continuous playback can be performed. When the tape in the first deck reaches its end and stops, the other deck will automatically begin playback.

1. Load prerecorded tapes in DECK I and DECK II.
2. Set the DOLBY NR switch.

- Always set the switches to the same positions that were used for recording.

[CT-W503R/CT-W403R]

3. Set the REV MODE switch to (see page 12).
4. Set the stereo amplifier for tape playback.

5. Press the playback (▶ or ◀) button of the deck that will start to play first.

- When the tape in one deck ends, the other deck automatically begins playback.
- To cancel relay playback, press the stop (■) button.

[CT-W503R only]

To improve high frequency sound during playback in tapes with poor recordings

Press the FLEX button and playback the tape.

Turn the AUTO NR system on before playing back tapes for convenience

When the type of Dolby NR system (B/C) used during recording of a tape is not clear, or if the Dolby NR system was not used during recording, please turn the AUTO NR on. The AUTO NR will select the most appropriate Dolby NR system automatically (see page 8).

NOTES:

- Relay playback can begin from either DECK I or DECK II.
- The tape in the idle deck can be replaced during relay playback mode, allowing many tapes to be played back continuously. This is a convenient feature for parties, background music, etc.
- When this mode is selected, if the deck encounters an unrecorded portion of tape more than 15 seconds in length, it will fast forward the tape until it encounters another recorded portion, and resume playback from that point.

To stop playback temporarily (DECK II only)

Press the pause (||) button.

- To resume playback, either press the pause (||) button again, or press the playback (▶ or ◀) button.

To stop playback

Press the stop (■) button of the operating deck.

PLAYBACK

PLAYBACK SEQUENCE WITH REV MODE SWITCH SETTING

The playback sequence depends on the setting of the REV MODE switch and on which playback (▶ or ◀) button is pressed first. The playback sequence for each possible selection is shown below.

*2 In the repeat (↺) mode, relay playback always begins from the forward direction.

I ▶ : DECK I forward playback II ◀ : DECK II reverse playback
I ◀ : DECK I reverse playback ∞ : Auto-reverse function
II ▶ : DECK II forward playback → : Relay

[CT-W503R only]

REV MODE switch	Starting playback button	Another deck mode	Playback sequence
↺	DECK I ▶	* 2	I ▶ ∞ ◀ → II ▶ ∞ ◀ → I ▶ ∞ ◀ ... 15 times relay (32 sides playback)
↺	DECK I ◀	* 2	I ◀ → II ▶ ∞ ◀ → I ▶ ∞ ◀ → II ▶ ... 15 times relay (31 sides playback)
↺	DECK II ▶	* 2	II ▶ ∞ ◀ → I ▶ ∞ ◀ → II ▶ ∞ ◀ ... 15 times relay (32 sides playback)
↺	DECK II ◀	* 2	II ◀ → I ▶ ∞ ◀ → II ▶ ∞ ◀ → I ▶ ... 15 times relay (31 sides playback)

[CT-W403R only]

REV MODE switch	Starting playback button	Another deck mode	Playback sequence
↺	DECK I ▶	* 2	I ▶ → II ▶ ∞ ◀ → * I ▶ → II ▶ ... 15 times relay (24 sides)
↺	DECK II ▶	* 2	II ▶ → ∞ ◀ → I ▶ → II ▶ ∞ ◀ → * I ▶ ... 15 times relay (24 sides)
↺	DECK II ◀	* 2	II ◀ → I ▶ → II ▶ ∞ ◀ → * I ▶ ... 15 times relay (23 sides)

* Deck I is rewound automatically while Deck II is playing so that relay playback continues smoothly.

[CT-W203 only]

When the RELAY/SKIP ON/OFF switch is set to ON, the playback sequence will be as follows.

I ▶ → II ▶ → I ▶ → II ▶ ...
(16 sides playback)

II ▶ → I ▶ → II ▶ → I ▶ ...
(16 sides playback)

MUSIC SEARCH

(Skipping forward or backward to playback a desired selection)

The music search function detects blanks (longer than 4 seconds) between selections, advances the tape in the forward or reverse direction to find the beginning of the desired selection and automatically starts playback.

It can find a selection located up to 15 selections before or after the present position.

During forward playback

When you wish to locate a future song, press the ▶▶ button as many times as the number of songs to be skipped. When you wish to listen to the song currently being played from the beginning, press the ◀◀ button once. To return to a previous song or beyond, press the ◀◀ button as many times as the number of songs to be skipped, plus one.

During reverse playback (Except for the Deck I of CT-W403R and both deck of CT-W203)

When you wish to locate a future song, press the ◀◀ button as many times as the number of songs to be skipped. When you wish to listen to the song currently being played from the beginning, press the ▶▶ button once. To return to a previous song, press the ▶▶ button as many times as the number of songs to be skipped plus one.

From the stop mode

Press the playback (▶ or ◀) button to set the playback mode, then press the ◀◀ or ▶▶ button to perform music search as mentioned above.

- If the button is pressed more times than the number of selection recorded on the tape, forward search will continue on the opposite side, but reverse search will stop at the tape end. (Except for the Deck I of CT-W403R and both deck of CT-W203)

NOTES:

In the following circumstances, the music search function may be unable to properly detect blanks between selections; this is not, however, a sign of a malfunction with the unit.

- When using a tape with blanks between selections less than 4 seconds long.
- When listening to tapes with long low-level intervals, like classical music, or with sound breaks several seconds long within selections.
- When listening to recorded conferences or talk shows, where sound is intermittent.
- When using tapes with noise in the blanks between selections.

How Selections are counted

When starting the music search operation from the middle of a selection and specifying "1st previous selection," playback will return to the beginning of the present selection. To return to selections further back, count one extra selection.

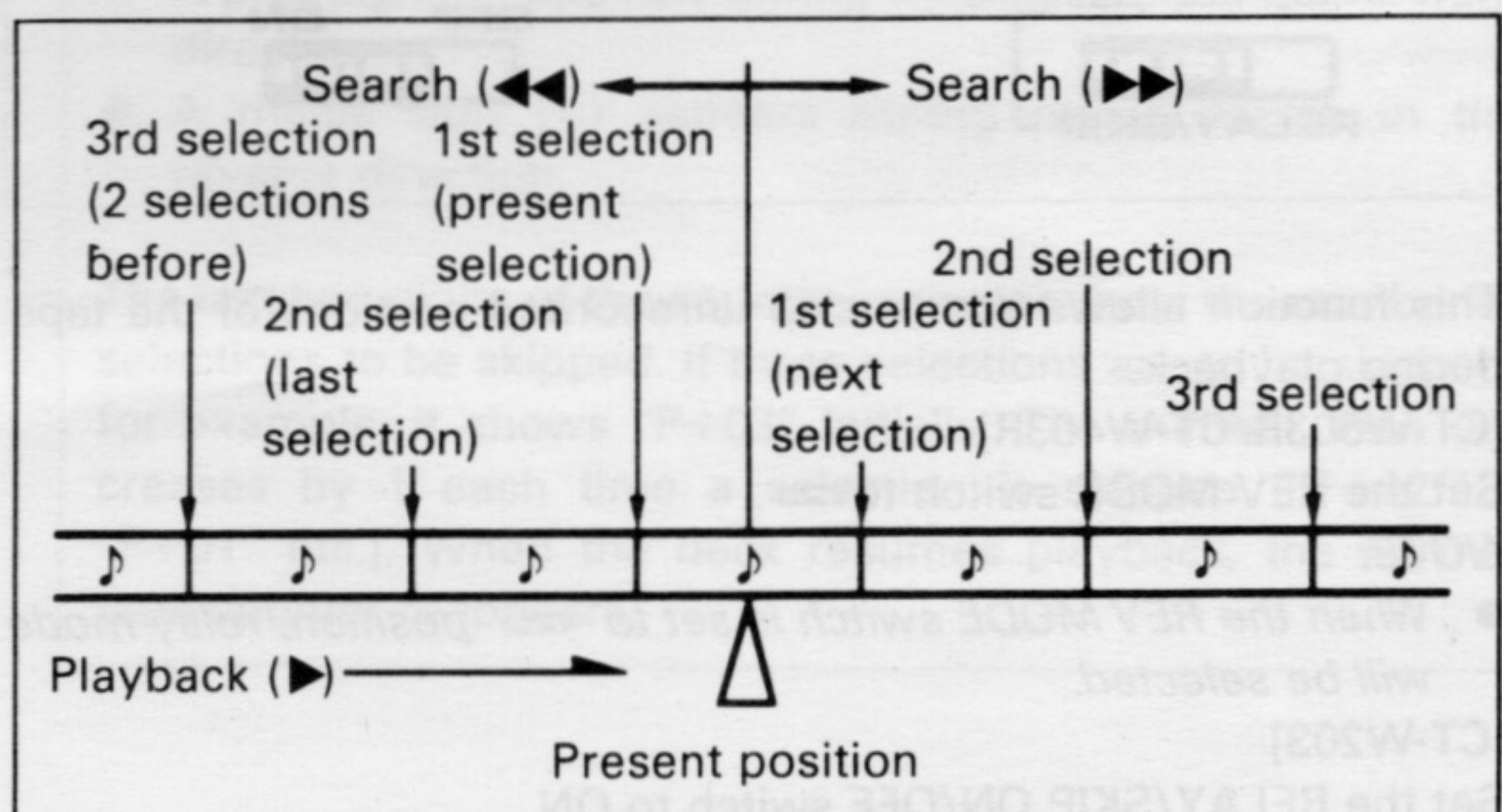

RECORDING

RECORDING (Deck II only)

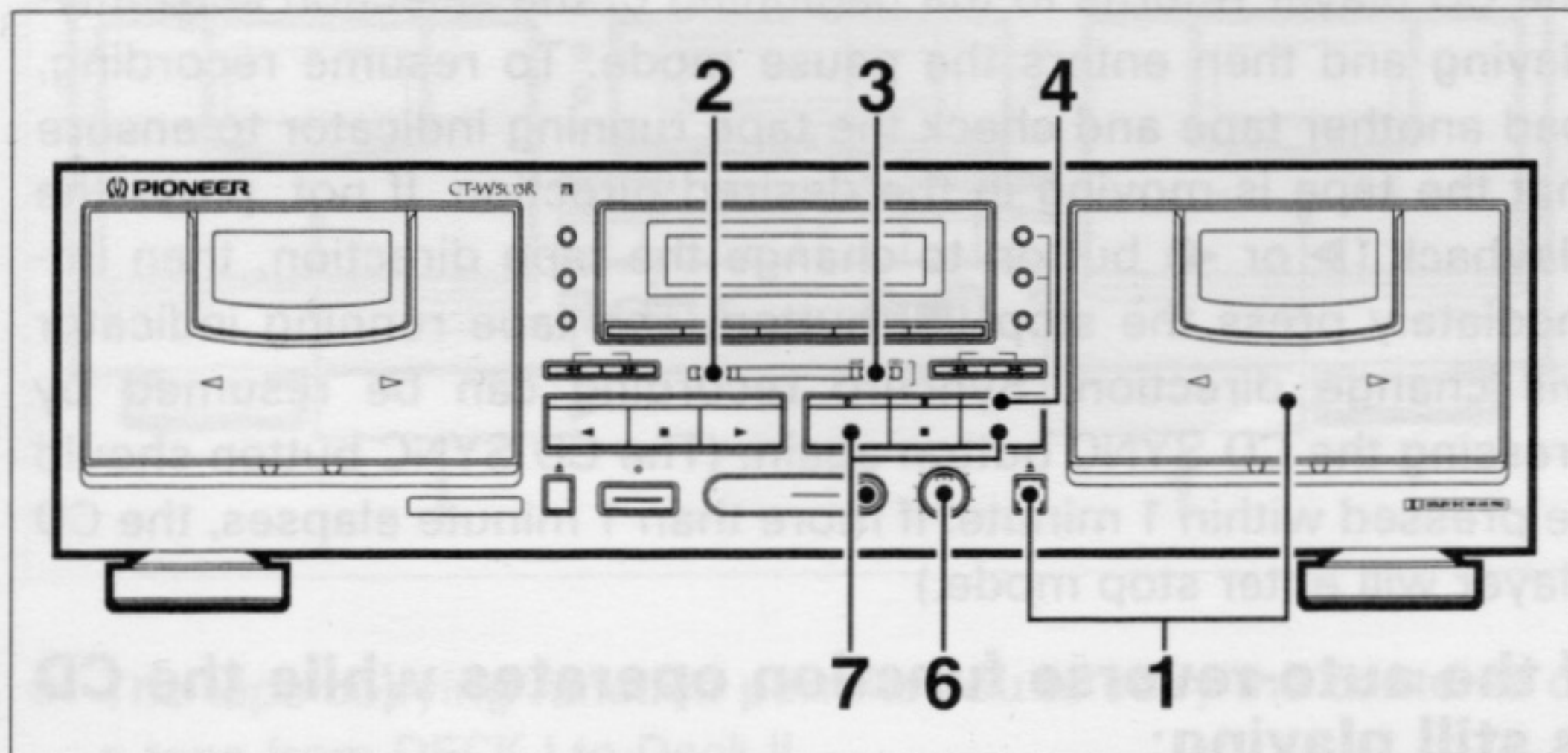

1. Load a tape for recording in Deck II.
2. Set the DOLBY NR switch.
3. Set the REV MODE switch. (Except for CT-W203)
 - To record on one side only, set the switch to the \Rightarrow position. To record on both sides, set the switch to either the \Rightarrow or the \Leftarrow position.
4. Press the recording (●) button.
5. Prepare the audio source from which you wish to record. Turn on the stereo amplifier and prepare it for playback of the desired audio source.
6. Adjust the recording level. For details, see "ADJUSTING THE RECORDING LEVEL" below.
7. Press the playback (▶ or ◀) button or the pause (||) button to begin recording.
 - When recording on both sides, press the ▶ button. If the ◀ button is pressed, recording will stop after only one side is reorded. (Except for CT-W203)

To stop recording temporarily

Press the pause (||) button.

- To resume recording, either press the pause (||) button again, or press the playback (▶ or ◀) button.

To Stop Recording

Press the stop (■) button.

Erasure prevention tabs

The recording (●) button does not work when the erasure prevention tabs of the loaded cassette tape have been broken off. (See page 5.) Do not press the recording (●) button with unreasonable force. When recording on both sides, make sure that both tabs are intact.

ADJUSTING THE RECORDING LEVEL

The adjustment of the recording level is the most important factor in achieving good recording results. A high level provides a good signal-to-noise ratio and dynamic range, but an excessively high level distorts the sound. If the level is set too low for fear of sound distortion, irritating tape hiss will mar the recording. The characteristics of tapes differ depending on the manufacturer and the type of tape. Set the REC LEVEL control so that the level meter's

"-3 dB" indicator lights steadily most of the time. No harm will be done if the "0 dB" indicator lights momentarily at peaks. When recording without Dolby NR, set the REC LEVEL control so that the "-3 dB" indicator lights, and the "0 dB" indicator lights occasionally at peaks.

NOTES:

- The optimal recording level may differ somewhat depending on the audio source and type of tape used. In order to obtain the best possible results, set the recording level after actual testing. Listen to your recordings, and adjust the level as necessary.
- The level meter may react differently during recording and playback of the same tape. This is due to differences in tape sensitivity, and creates no problem.

RECORDING MUTE

Use this function to create the 4.5-second blanks required for proper operation of the music search function.

- Press the recording mute (○) button during recording and the deck will create a blank space by recording a section which contains no signal for approximately four seconds. The deck will then enter recording standby mode.
- To create a blank which is more than four seconds long, hold the button down for the desired length of time. When the button is released, the deck will enter recording standby mode.
- To resume recording, press the pause (||) button or the playback (▶ or ◀) button.

ERASING A TAPE

To erase the recorded contents of a tape, load the tape in DECK II and follow the procedure below.

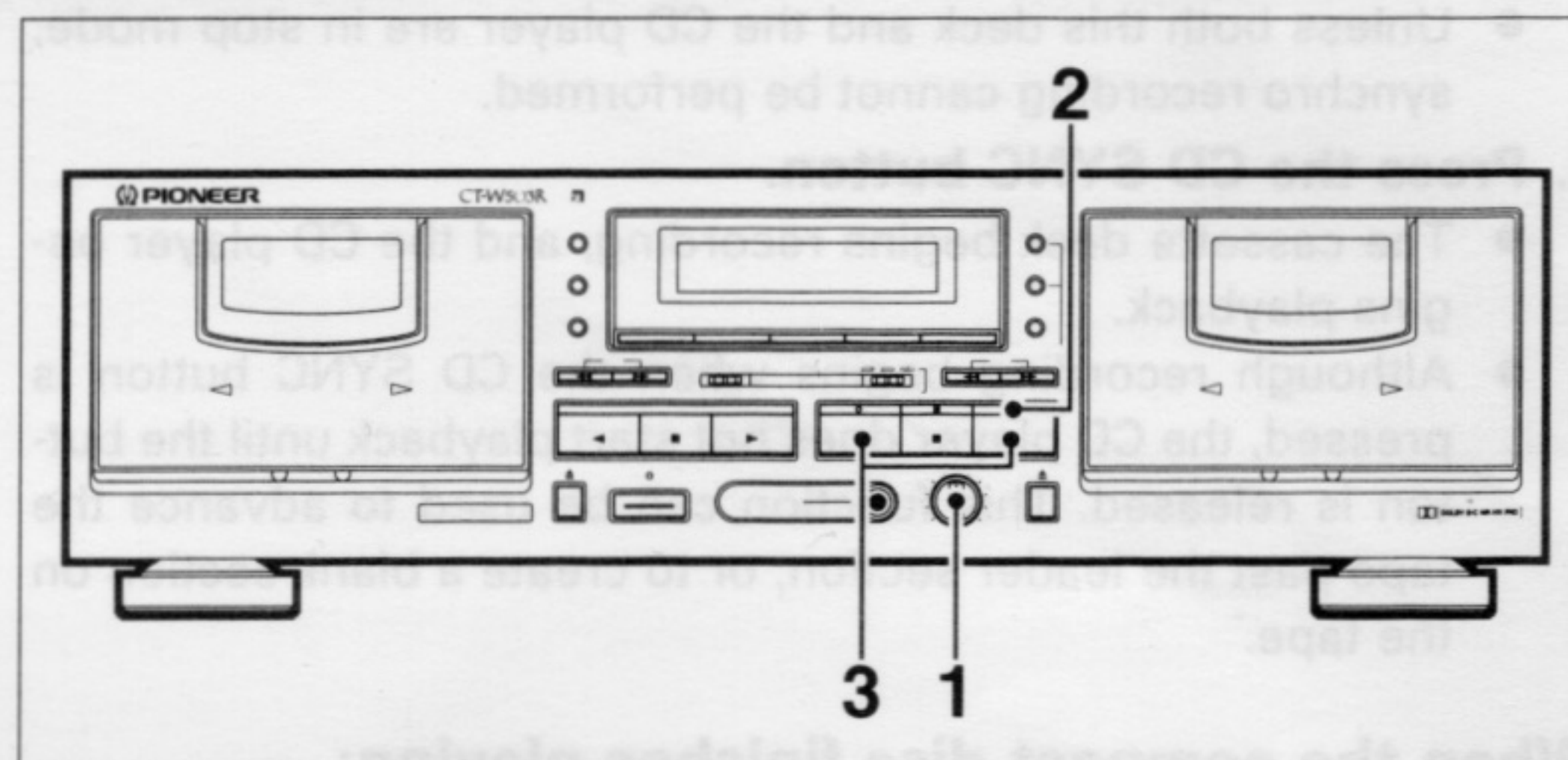

1. Set the REC LEVEL control to the MIN position.
2. Press the recording (●) button.
3. Press the playback (▶ or ◀) button or the pause (||) button.

CD · DECK SYNCHRO RECORDING (CT-W503R only)

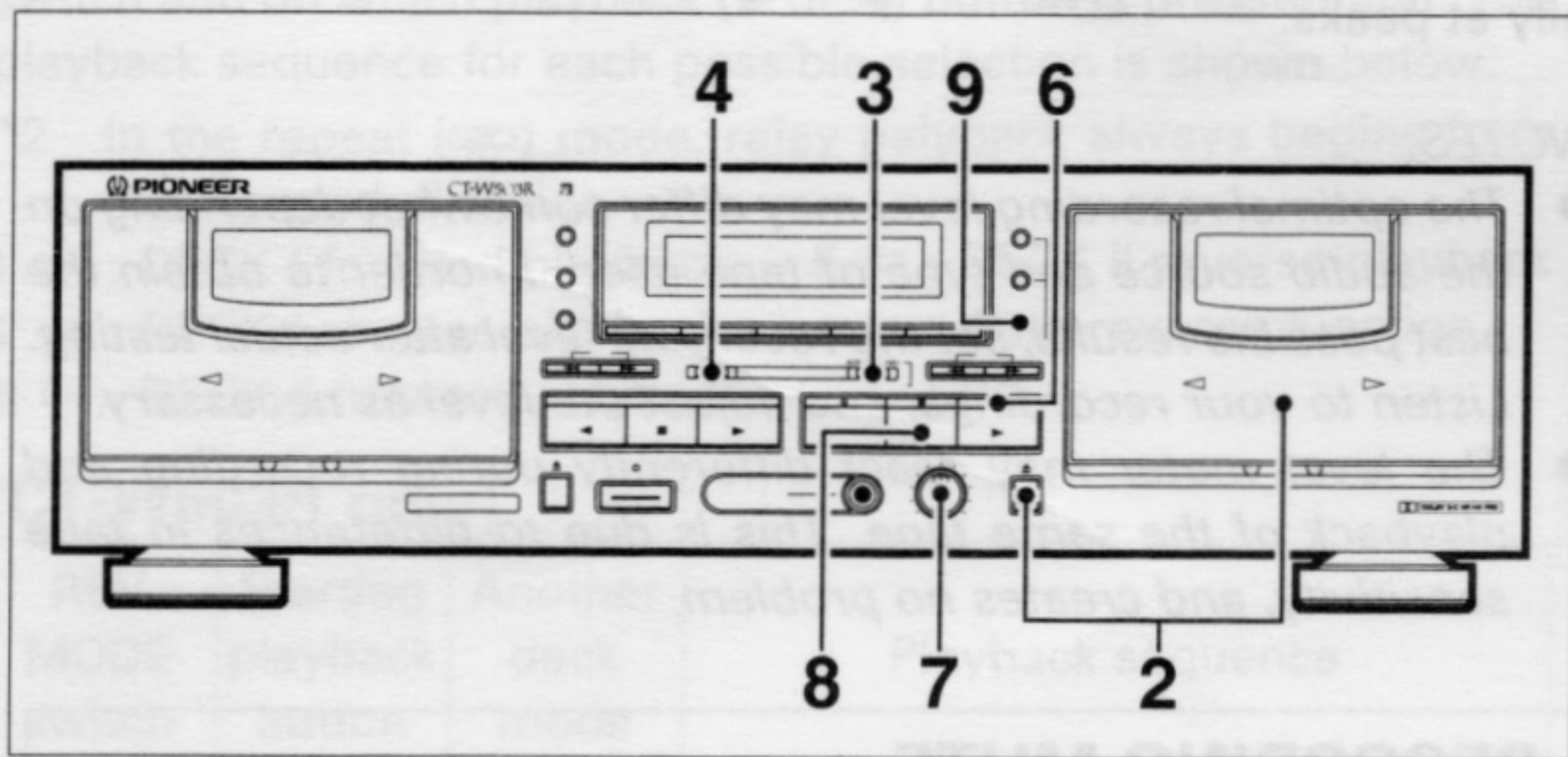

If the CD player has a program function to determine the order of playback, program the CD player before beginning this operation.

1. **Load a compact disc in the CD player.**
2. **Load the cassette for recording.**
 - Rewind the tape to the desired starting position.
3. **Set the REV MODE switch.**
 - To record on one side only, set the switch to the \rightleftharpoons position. To record on both sides, set the switch to either the \leftarrow or the \rightarrow position.
4. **Set the DOLBY NR switch.**
5. **Press the play button of the CD player.**
6. **Press the recording (●) button.**
7. **Adjust the recording level.**
 - See page 13.
8. **Press the stop (■) button of both the cassette deck and the CD player.**
 - Unless both this deck and the CD player are in stop mode, synchro recording cannot be performed.
9. **Press the CD SYNC button.**
 - The cassette deck begins recording, and the CD player begins playback.
 - Although recording begins when the CD SYNC button is pressed, the CD player does not start playback until the button is released. This function can be used to advance the tape past the leader section, or to create a blank section on the tape.

When the compact disc finishes playing:

The CD player enters stop mode and the cassette deck enters recording standby mode. Change the disc and press the play button of the CD player to resume recording. If the CD player does not resume play within one minute, the cassette deck enters stop mode.

When the CD player changes discs (twin tray or multi-play disc CD players):

The cassette deck enters recording standby mode, and resumes recording when the CD player begins playing the next disc. A four-second blank space is automatically created between tracks.

When the end of the tape is reached while the CD player is still playing:

The CD player returns to the beginning of the selection currently playing and then enters the pause mode. To resume recording, load another tape and check the tape running indicator to ensure that the tape is moving in the desired direction. If not, press the playback (▶ or ◀) button to change the tape direction, then immediately press the stop (■) button. The tape running indicator will change direction. Synchro recording can be resumed by pressing the CD SYNC button again. (The CD SYNC button should be pressed within 1 minute. If more than 1 minute elapses, the CD player will enter stop mode.)

If the auto-reverse function operates while the CD is still playing:

The CD player returns to the beginning of the current selection and enters pause mode.

A ten-second blank space is automatically created on the reverse side, then the CD player resumes playback and the deck resumes recording.

NOTES:

- The CD · DECK SYNCHRO function only works with PIONEER CD players equipped with the CD · DECK SYNCHRO function.
- Be sure to connect the deck and the CD player with the CD · DECK SYNCHRO control cord.
- Only PIONEER CD players equipped with a CD · DECK SYNCHRO jack can be used for CD · DECK SYNCHRO recording. Any type of CD player which meets these requirements, including twin-tray or multi-play models, can be used.

TAPE COPYING (from DECK I to DECK II)

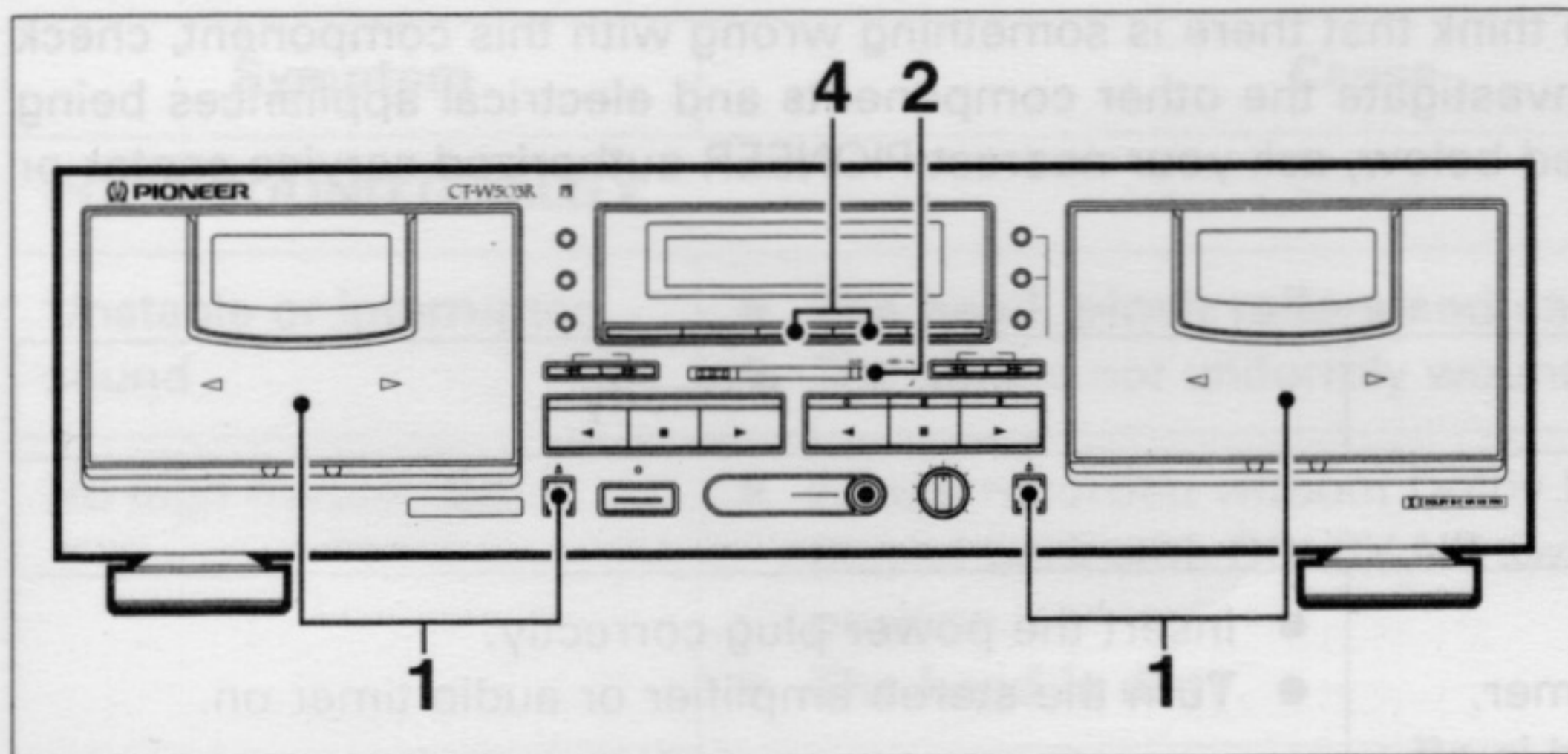

- The tape copying function permits you to copy the contents of a tape from DECK I to Deck II.
- The SYNCHRO COPY button is used to select either normal speed copying, or high-speed copying (copying at twice the normal playback speed).

1. Load a tape for playback into DECK I and a tape for recording into Deck II.

[CT-W503R/CT-W403R]

2. Set the REV MODE switch.

3. Set the tape transport direction.

- Tape copying is always performed in the direction indicated by the tape transport indicator (▶ or ◀). To change this direction, press the desired playback button (▶ or ◀), then immediately press the stop (■) button.

4. Press the SYNCHRO COPY button to select either NORMAL or HIGH speed.

NORMAL: Tape copying at normal speed allows listen during playback (COPY indicator lights steadily).

HIGH: Tape copying at twice the normal speed (COPY indicator flashes). Playback will still audible.

To stop copying

Press the stop (■) button of either deck. Both decks will stop.

NOTES:

- **The tape in DECK II will be copied in the same type of the DOLBY NR switch as DECK I's tape, regardless of its own setting. When listening to the copied tape, set the type of the DOLBY NR switch.**
- If a nearby television set is on while high-speed copying is being performed, a high-pitched interference sound may be heard on the tape. In this case, either use the normal speed copying function, or turn off the television.
- During high-speed copying, none of the operation buttons will function except for the stop (■) button.
- During normal speed copying, the recording mute (○) and pause (||) buttons of deck II also function.
- Tape copying is cancelled when either of the two tapes reaches the end. Therefore it is advisable to use tapes of the same length.
- The sound quality of the copied tape will be somewhat less than the original. Therefore when making more than one copy, always record from the original tape (do not make a copy of a copy).
- The recording level adjustment is not necessary during tape copying.

TROUBLESHOOTING

Incorrect operations are often mistaken for trouble and malfunctions. If you think that there is something wrong with this component, check the points below. Sometimes the trouble may lie in another component. Investigate the other components and electrical appliances being used. If the trouble cannot be rectified even after exercising the checks listed below, ask your nearest PIONEER authorized service center or your dealer to carry out repair work.

Symptom	Cause	Remedy
POWER		
Cannot turn power on.	<ul style="list-style-type: none"> ● The power plug is removed. ● The component (stereo amplifier, audio timer, etc.) to which the power cord is connected is off. 	<ul style="list-style-type: none"> ● Insert the power plug correctly. ● Turn the stereo amplifier or audio timer on.
CASSETTE DOOR		
The door does not open.	<ul style="list-style-type: none"> ● The deck is not in stop mode (tape is moving). ● Power was turned off with the tape moving. 	<ul style="list-style-type: none"> ● Press the stop (■) button. ● Turn power on.
The door does not close.	<ul style="list-style-type: none"> ● The cassette is not properly loaded. 	<ul style="list-style-type: none"> ● Reinsert the cassette.
PLAYBACK		
Immediately stops.	<ul style="list-style-type: none"> ● The tape is completely wound. ● The tape is slack. 	<ul style="list-style-type: none"> ● Play back in the opposite direction. ● Rewind the tape. ● Take up slack (see page 5).
The level meter does not work.	<ul style="list-style-type: none"> ● The tape is not prerecorded. ● The tape head is dirty. 	<ul style="list-style-type: none"> ● Replace the tape with a prerecorded one. ● Clean the heads (see page 4).
No sound	<ul style="list-style-type: none"> ● The amplifier input selector is not correctly set. ● The amplifier volume level setting is too low. ● Connection problems (wrong connection, cord removed, poor contact, broken wire.) 	<ul style="list-style-type: none"> ● Set the amplifier input selector correctly. ● Turn the amplifier volume control up. ● Connect securely (see page 6).
RECORDING		
The recording indicator does not light up.	<ul style="list-style-type: none"> ● The cassette erasure prevention tabs are broken. 	<ul style="list-style-type: none"> ● Replace the cassette with one whose tabs are intact. ● Cover the hole over the tab (see page 5).
The level meter does not work.	<ul style="list-style-type: none"> ● REC LEVEL control is set too low. ● The amplifier is not delivering a recording signal (from the tuner, CD player, etc.). ● Wrong connection, connection cord removed, poor contact, broken wire. 	<ul style="list-style-type: none"> ● Turn REC LEVEL control up (see page 13). ● Set the amplifier recording output selector correctly. ● Check connections (see page 6).
Immediately stops.	<ul style="list-style-type: none"> ● The tape is completely wound up. ● The tape is slack. 	<ul style="list-style-type: none"> ● Record in the opposite direction. ● Rewind the tape. ● Take up slack (see page 5).
Cannot record	<ul style="list-style-type: none"> ● The head is dirty. 	<ul style="list-style-type: none"> ● Clean the head (see page 4).

Symptom	Cause	Remedy
POOR SOUND QUALITY		
Unstable or interrupted sound	<ul style="list-style-type: none"> ● The head, pinch rollers and capstans are dirty. ● The tape is not uniformly wound. 	<ul style="list-style-type: none"> ● Clean (see page 4). ● Completely fast-forward or rewind the tape.
No high frequencies	<ul style="list-style-type: none"> ● A tape recorded without Dolby NR is being played back with DOLBY NR switch in the B or C position. ● The head is dirty. 	<ul style="list-style-type: none"> ● Set DOLBY NR switch to OFF. ● Clean the head (see page 4).
High frequencies are emphasized.	<ul style="list-style-type: none"> ● A Dolby NR-encoded tape is being played back with DOLBY NR switch in the OFF position. 	<ul style="list-style-type: none"> ● Set DOLBY NR switch to the same position used for recording.
Sound from previous recordings remains when rerecording a tape.	<ul style="list-style-type: none"> ● The head is dirty. 	<ul style="list-style-type: none"> ● Clean the head (see page 4).
The sound is distorted.	<ul style="list-style-type: none"> ● Recording level is too high. ● The recorded signal itself is distorted. ● The head is dirty. 	<ul style="list-style-type: none"> ● Turn REC LEVEL control down when recording (see page 13). ● Replace the cassette. ● Clean the head (see page 4).
Too much noise	<ul style="list-style-type: none"> ● High noise tape is being used. ● Incomplete insertion of a connection cord, poor contact. ● Recording level is too low. ● The head is dirty. ● The head is magnetized. 	<ul style="list-style-type: none"> ● Replace the cassette. ● Check connections (see page 6). ● Turn REC LEVEL control up when recording (see page 13). ● Clean the head (see page 4). ● Demagnetize with a head demagnetizer.
OTHERS		
The music search function does not work.	<ul style="list-style-type: none"> ● Blanks between selections are less than 4 seconds long. 	<ul style="list-style-type: none"> ● Use a tape with blanks more than 4 seconds long.
Cannot use the remote control system.	<ul style="list-style-type: none"> ● The control cord is not connected. 	<ul style="list-style-type: none"> ● Connect the control cord (see page 6).
CD · DECK SYNCHRO is disabled. (CT-W503R only)	<ul style="list-style-type: none"> ● The components are not connected properly. ● The cassette erasure prevention tabs are broken. 	<ul style="list-style-type: none"> ● Connect them properly (see page 6). ● Replace the cassette with one whose tabs are intact.
The CD SYNC indicator is off during CD · DECK SYNCHRO recording. (CT-W503R only)	<ul style="list-style-type: none"> ● The tape ran out during the CD · DECK SYNCHRO mode. ● After the deck entered recording standby mode, more than 1 minute elapsed before the CD player resumed playback. 	<ul style="list-style-type: none"> ● Replace the tape with a longer one. ● Change the disc and press the CD SYNC button again.

POWER-CORD CAUTION

Handle the power cord by the plug. Do not pull out the plug by tugging the cord and never touch the power cord when your hands are wet as this could cause a short circuit or electric shock. Do not place the unit, a piece of furniture, etc., on the power cord, or pinch the cord. Never make a knot in the cord or tie it with other cords. The power cords should be routed in such a way that they are not likely to be stepped on. A damaged power cord can cause fire or give you an electrical shock. Check the power cord regularly. When you find it damaged, ask your nearest PIONEER authorized service center or your dealer for a replacement.

SPECIFICATIONS

System	4-track, 2-channel stereo
Heads	"Hard Permalloy" recording/playback head × 1 "Head Permalloy" playback head × 1 "Ferrite" erasing head × 1
Motor	DC servo motor × 2
Wow and Flutter	0.1% (WRMS)
Fast Winding Time	Approximately 100 seconds (C-60 tape)
Frequency Response	
-20 dB recording:	
TYPE IV (Metal) tape	20 to 16,500 Hz
TYPE II (High/CrO ₂) tape	20 to 16,000 Hz
TYPE I (Normal) tape	20 to 16,000 Hz
Signal-to-Noise Ratio	
Dolby NR OFF	More than 57 dB
Noise Reduction Effect	
Dolby B-type NR ON	More than 10 dB (at 5 kHz)
Dolby C-type NR ON	More than 19 dB (at 5 kHz)
Harmonic Distortion	
CT-W503R/CT-W403R	No more than 0.8%
CT-W203	No more than 1% (at -4 dB: 160 nwb/m)
Input (Sensitivity)	
LINE (INPUT)	100 mV (Input impedance 68 kΩ)
Output (Reference level)	
LINE (OUTPUT)	0.5 V (Output impedance 1.9 kΩ (CT-W503R) 1.7 kΩ (CT-W403R/CT-W203))
Headphones	0.63 mW (Load impedance 8 Ω) (CT-W503 only)

Subfunctions

- Automatic reverse (Except for CT-W203)
- DOLBY HX PRO recording function (Except for CT-W203)
- DOLBY B/C type NR
- Music search over ±15 selections
- Synchronized copy start
- High-speed and normal-speed copy (Deck I → Deck II)
- Relay playback/blank skip
- CD · DECK SYNCHRO recording capability (CT-W503R only)
- Peak level meter with peak-hold function
- Automatic space recording mute
- Automatic tape selector
-  System remote control available (CT-W503R/CT-W403R/CT-W203: Australian models)
- 2-mode electronic 4-digit twin tape counter
- Headphone jack (CT-W503R only)
- FLEX system (CT-W503R only)
- Rewind-Auto play (CT-W403R/CT-W203)
- Auto NR system (CT-W503R only)

Miscellaneous

Power Requirements	
U.S. model	AC 120 V, 60 Hz
UK and Australian model	AC 230—240 V, 50/60 Hz
Power Consumption	
CT-W503R/CT-W403R	17 W
CT-W203	16 W
Dimensions	420(W) × 125(H) × 250(D) mm
Weight (without package)	
CT-W503R	4.2 kg
CT-W403R	3.9 kg
CT-W203	4.0 kg

Accessories

Operating instructions	1
Connection cord with pin plugs	2
 Remote control cord (CT-W503R/CT-W403R/CT-W203: Australian models)	1
CD · DECK SYNCHRO control cord (CT-W503R only)	1

NOTE:

Specifications and design subject to possible modifications without notice, due to improvements.

POWER-CORD CAUTION

Handle the power cord by the plug. Do not pull out the plug by tugging the cord and never touch the power cord when your hands are wet as this could cause a short circuit or electric shock. Do not place the unit, a piece of furniture, etc., on the power cord, or pinch the cord. Never make a knot in the cord or tie it with other cords. The power cord should be routed in such a way that they are not likely to be stepped on. A damaged power cord can cause fire or give you an electrical shock. Check the power cord regularly. When you find it damaged, ask your nearest PIONEER authorized service center or your dealer for a replacement.

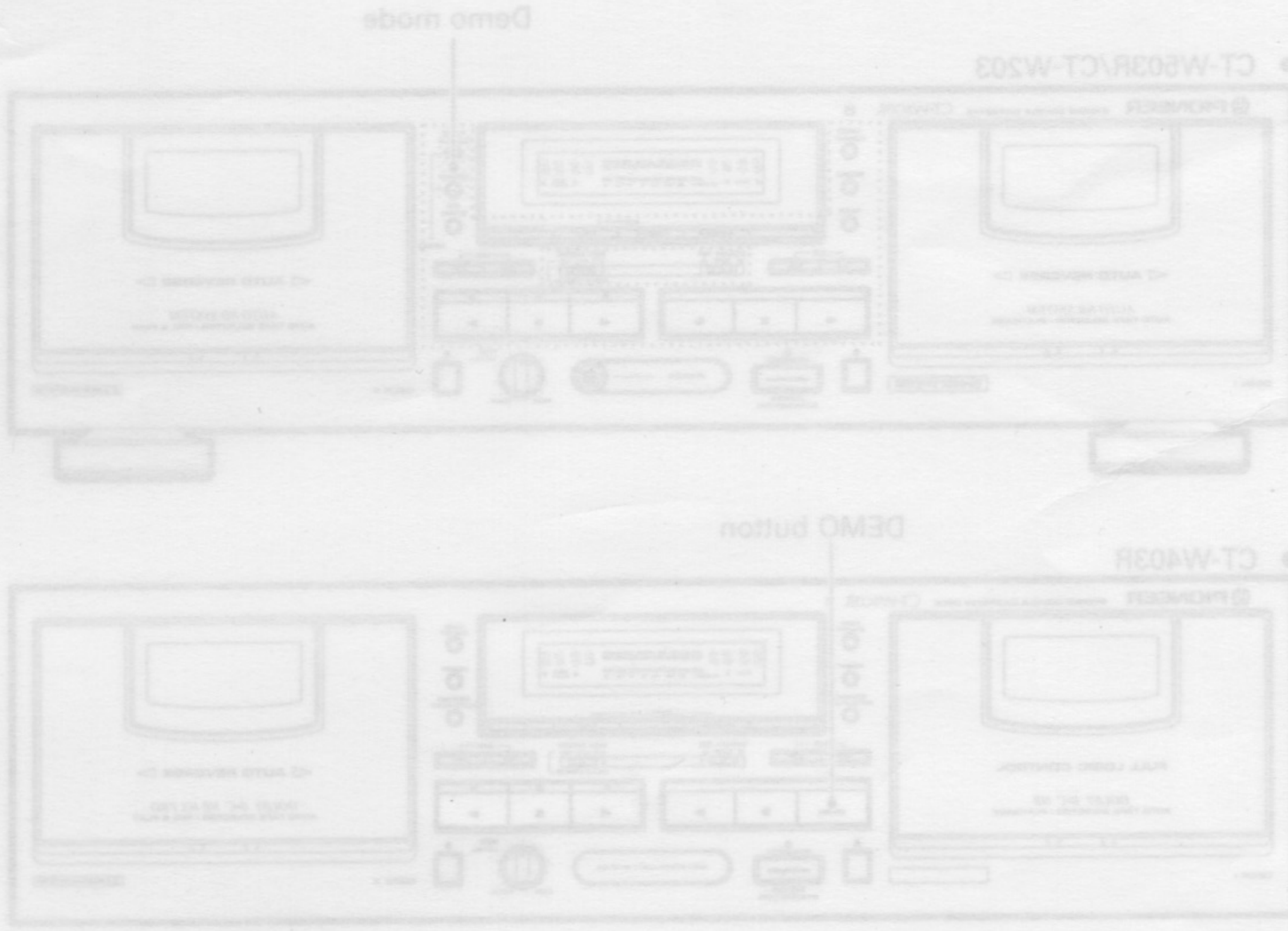

About the Demo mode

[CT-W503RCT-W203]
 Press the DECK II counter reset button (RESET) and the DECK II counter mode button (TIME\COUNT) simultaneously to set the demonstration mode.

[CT-W403R]
 Press the DEMO button to set the demonstration mode. To cancel the demonstration mode, press any one of the buttons enclosed in the dotted lines above.

Published by Pioneer Electronic Corporation
 Copyright © 1993 Pioneer Electronic Corporation
 All rights reserved.

PIONEER ELECTRONIC CORPORATION 4-1, Meguro 1-Chome, Meguro-ku, Tokyo 153, Japan
PIONEER ELECTRONICS (USA) INC. 3255 East 21st Street, Long Beach, California 90810, U.S.A.
PIONEER ELECTRONICS OF CANADA INC. 300 Allstate Parkway Markham, Ontario L3R 9P2, Canada
PIONEER ELECTRONIC (EUROPE) N.V. Haven 1087 Keizergracht 1, 9720 Meibate, Belgium, TEL: 037250 02 11
PIONEER ELECTRONICS AUSTRALIA PTY LTD. 178-184 Boundary Road, Burswood, Victoria 3195, Australia, TEL: (03) 560 9911

SPECIFICATIONS

● CT-W503R/CT-W203

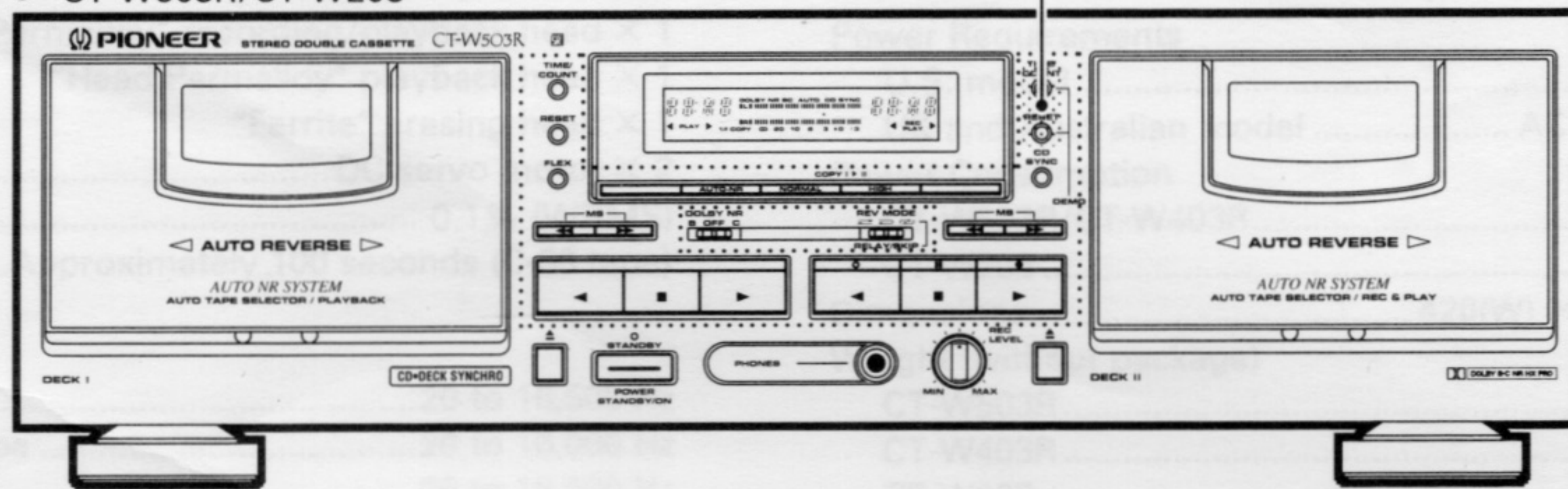

● CT-W403R

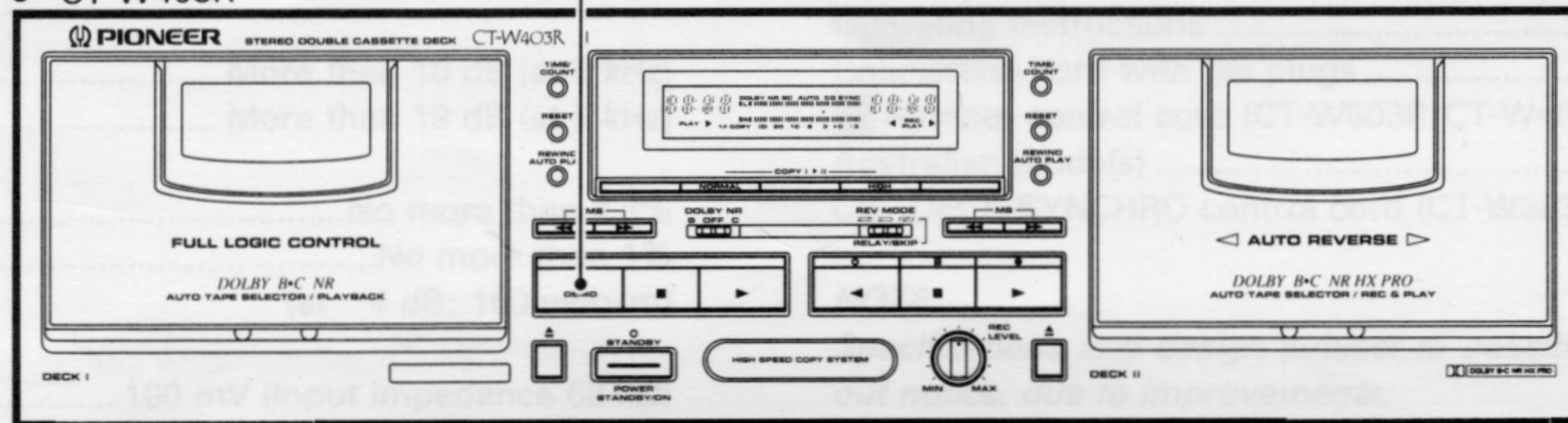

About the Demo mode

[CT-W503R/CT-W203]

Press the DECK II counter reset button (RESET) and the DECK II counter mode button (TIME/COUNT) simultaneously to set the demonstration mode.

[CT-W403R]

Press the DEMO button to set the demonstration mode. To cancel the demonstration mode, press any one of the buttons enclosed in the dotted lines above.

Published by Pioneer Electronic Corporation.
Copyright © 1993 Pioneer Electronic Corporation.
All rights reserved.

PIONEER ELECTRONIC CORPORATION 4-1, Meguro 1-Chome, Meguro-ku, Tokyo 153, Japan

PIONEER ELECTRONICS [USA] INC. 2265 East 220th Street, Long Beach, California 90810, U.S.A.

P.O. BOX 1720, Long Beach, California 90801, U.S.A.

PIONEER ELECTRONICS OF CANADA, INC. 300 Allstate Parkway Markham, Ontario L3R 0P2, Canada

PIONEER ELECTRONIC [EUROPE] N.V. Haven 1087 Keetberglaan 1, 9120 Melsele, Belgium, TEL: 03/750.05.11

PIONEER ELECTRONICS AUSTRALIA PTY. LTD. 178-184 Boundary Road, Braeside, Victoria 3195, Australia, TEL: [03] 580-9911