

Service  
Service  
**Service**

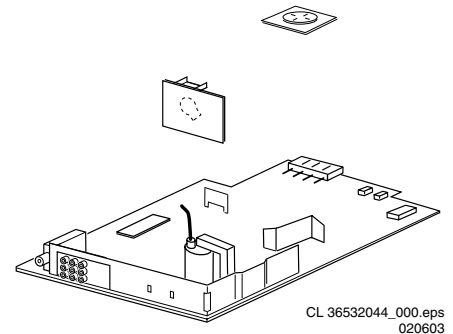

# Service Manual

<b>Contents</b>	<b>Page</b>	
1. Technical Specifications, Connections, and Chassis Overview		2
2. Safety Instructions, Warnings, and Notes		4
3. Directions for Use		7
4. Mechanical Instructions		8
5. Service Modes, Error Codes, and Fault Finding		9
6. <i>Block Diagrams, Test Point Overviews, and Waveforms</i>		
Block Diagram		13
I2C and Supply Voltage Overview		14
Testpoint Overview Mono Carrier and CRT Panel		15
7. <i>Circuit Diagrams and PWB Layouts</i>	<i>Diagram</i>	<i>PWB</i>
Mono Carrier: Power Supply	(A1) 16	26-31
Mono Carrier: Deflection	(A2) 17	26-31
Mono Carrier: Tuner IF	(A3) 18	26-31
Mono Carrier: Video Processing	(A4) 19	26-31
Mono Carrier: Audio Processing	(A5) 20	26-31
Mono Carrier: Audio Amplifier	(A6) 21	26-31
Mono Carrier: Font I/O + Control + HP	(A7) 22	26-31
Mono Carrier: Rear I/O Cinch	(A8) 23	26-31
Mono Carrier: Diversity Table for Rear I/O	(A8) 24	26-31
Mono Carrier: DVD Power Supply (Optional)	(A9) 25	26-31
CRT Panel	(B1) 32	33
Side AV Panel	(D) 34	35
Top Control Panel	(E) 36	36
8. Alignments		37
9. Circuit Descriptions, List of Abbreviations, and IC Data Sheets		
Data Sheets		44
Abbreviation List		47
IC Data Sheets		49
10. Spare Parts List		50
11. Revision List		55

©Copyright 2006 Philips Consumer Electronics B.V. Eindhoven, The Netherlands.  
All rights reserved. No part of this publication may be reproduced, stored in a retrieval system or transmitted, in any form or by any means, electronic, mechanical, photocopying, or otherwise without the prior permission of Philips.



# 1. Technical Specifications, Connections, and Chassis Overview

**Index of this chapter:**

- 1.1 Technical Specifications
- 1.2 Connections
- 1.3 Chassis Overview

## 1.1 Technical Specifications

### 1.1.1 Reception

Tuning system	: PLL
Color systems	: NTSC M
Sound systems	: Mono, or : BTSC with SAP
A/V connections	: NTSC M
Channel selections	: 181 Presets/ : Channels
	: Full-Cable
IF frequency	: 45.75 MHz
Aerial input	: 75 ohm (F type), Coax

### 1.1.2 Miscellaneous

Audio output	: Mono: 3 W rms
	: Bionic (mono): 2 x : 1.5 W rms
	: Stereo: 2 x 3 W rms
Mains voltage	: 90 - 132 V (± 10 %)
Mains frequency	: 50 / 60 Hz (± 5 %)
Ambient temperature	: + 5 to + 45 °C
Minimum air pressure	: 60 kPa (= 600 mBar)
Maximum humidity	: 90 %
Power consumption	: 36 W (14") to : 50 W (21") : 105 W (27")
Standby Power consumption	: < 3 W

## 1.2 Connections

### 1.2.1 Side Connections

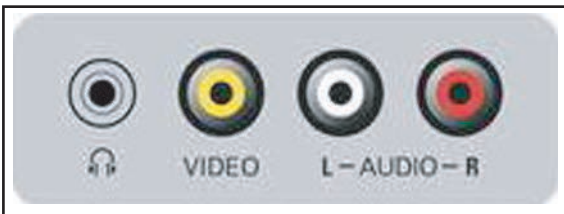

G\_13933\_015.eps  
030506

**Figure 1-1 Side Connections.**

**Headphone**

Bk - Headphone, 3.5 mm	8 - 600 Ω / 4 mW	
------------------------	------------------	--

**Audio / Video In**

Ye - Video	1 Vpp / 75 ohm	
Wh - Audio L	Mono 0.2 Vrms / 10 kohm	
Rd - Audio R	Mono 0.2 Vrms / 10 kohm	

### 1.2.2 Rear Connections

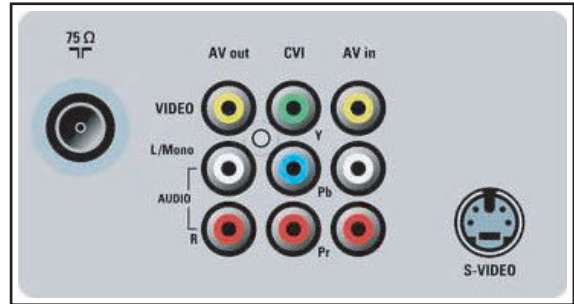

G\_13933\_016.eps  
030506

**Figure 1-2 Rear Connections.**

**Cinch: AV Out**

Ye - Video	1 Vpp / 75 ohm	
Wh - Audio	L (0.5 Vrms / 1 kohm)	
Rd - Audio	R (0.5 Vrms / 1 kohm)	

**Cinch: Video YPbPr - In**

Gn - Video Y	1 Vpp / 75 ohm	
Bu - Video Pb	0.7 Vpp / 75 ohm	
Rd - Video Pr	0.7 Vpp / 75 ohm	

**Cinch: AV1 In**

Ye - Video	1 Vpp / 75 ohm	
Wh - Audio	L (0.5 Vrms / 10 kohm)	
Re - Audio	R (0.5 Vrms / 10 kohm)	

**S-Video (Hosiden): Video Y/C - In**

1 - Ground Y	Gnd	
2 - Ground C	Gnd	
3 - Video Y	1 Vpp / 75 ohm	
4 - Video C	0.3 Vpp / 75 ohm	

**FM Ant**

1 - F type	75 ohm, coax.	
------------	---------------	--

1.3 Chassis Overview

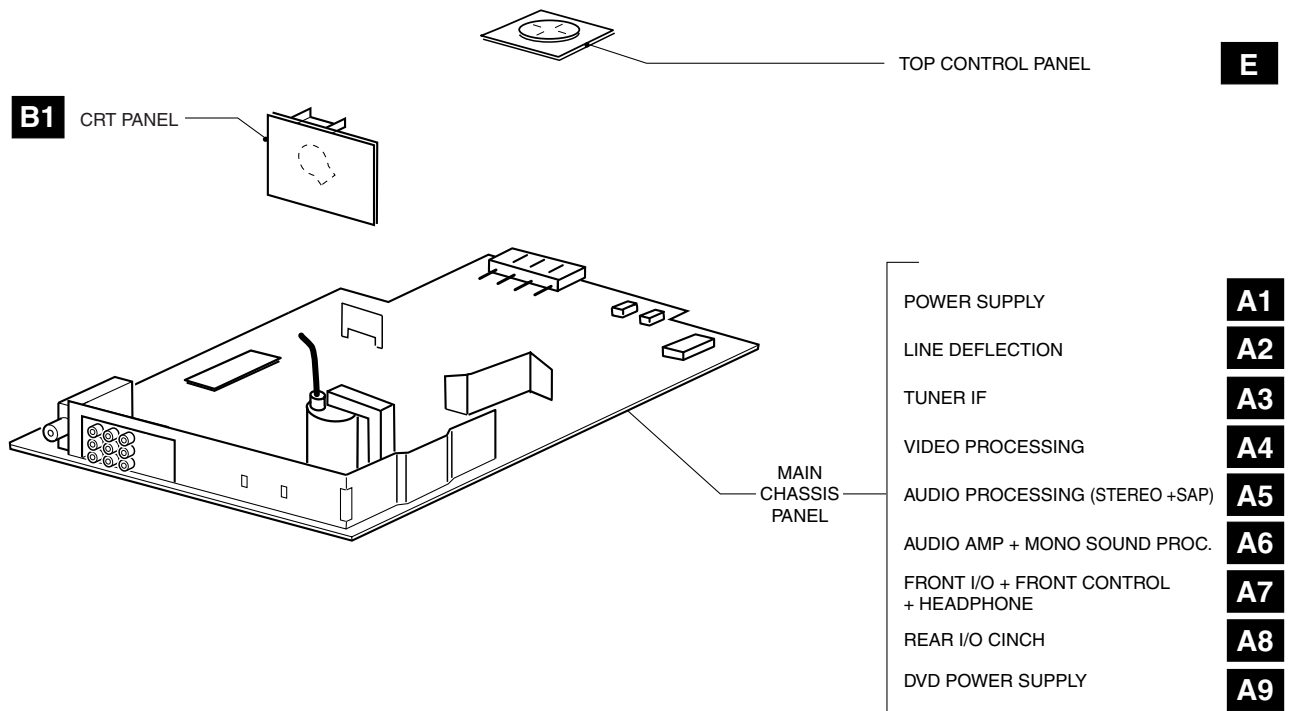

CL 36532044\_021.eps  
020603

Figure 1-3 Chassis overview

## 2. Safety Instructions, Warnings, and Notes

### Index of this chapter:

- 2.1 Safety Instructions
- 2.2 Maintenance Instructions
- 2.3 Warnings
- 2.4 Notes

### 2.1 Safety Instructions

Safety regulations require the following **during** a repair:

- Connect the set to the Mains/AC Power via an isolation transformer (> 800 VA).
- Replace safety components, indicated by the symbol **▲**, only by components identical to the original ones. Any other component substitution (other than original type) may increase risk of fire or electrical shock hazard.
- Wear safety goggles when you replace the CRT.

Safety regulations require that **after** a repair, the set must be returned in its original condition. Pay in particular attention to the following points:

- General repair instruction: as a strict precaution, we advise you to re-solder the solder connections through which the horizontal deflection current flows. In particular this is valid for the:
  1. Pins of the line output transformer (LOT).
  2. Fly-back capacitor(s).
  3. S-correction capacitor(s).
  4. Line output transistor.
  5. Pins of the connector with wires to the deflection coil.
  6. Other components through which the deflection current flows.

**Note:** This re-soldering is advised to prevent bad connections due to metal fatigue in solder connections, and is therefore only necessary for television sets more than two years old.

- Route the wire trees and EHT cable correctly and secure them with the mounted cable clamps.
- Check the insulation of the Mains/AC Power lead for external damage.
- Check the strain relief of the Mains/AC Power cord for proper function, to prevent the cord from touching the CRT, hot components, or heat sinks.
- Check the electrical DC resistance between the Mains/AC Power plug and the secondary side (only for sets that have a Mains/AC Power isolated power supply):
  1. Unplug the Mains/AC Power cord and connect a wire between the two pins of the Mains/AC Power plug.
  2. Set the Mains/AC Power switch to the "on" position (keep the Mains/AC Power cord unplugged!).
  3. Measure the resistance value between the pins of the Mains/AC Power plug and the metal shielding of the tuner or the aerial connection on the set. The reading should be between 4.5 Mohm and 12 Mohm.
  4. Switch "off" the set, and remove the wire between the two pins of the Mains/AC Power plug.
- Check the cabinet for defects, to prevent touching of any inner parts by the customer.

### 2.2 Maintenance Instructions

We recommend a maintenance inspection carried out by qualified service personnel. The interval depends on the usage conditions:

- When a customer uses the set under normal circumstances, for example in a living room, the recommended interval is three to five years.
- When a customer uses the set in an environment with higher dust, grease, or moisture levels, for example in a kitchen, the recommended interval is one year.
- The maintenance inspection includes the following actions:

1. Perform the "general repair instruction" noted above.
2. Clean the power supply and deflection circuitry on the chassis.
3. Clean the picture tube panel and the neck of the picture tube.

### 2.3 Warnings

- In order to prevent damage to ICs and transistors, avoid all high voltage flashovers. In order to prevent damage to the picture tube, use the method shown in figure "Discharge picture tube", to discharge the picture tube. Use a high voltage probe and a multi-meter (position  $V_{DC}$ ). Discharge until the meter reading is 0 V (after approx. 30 s).

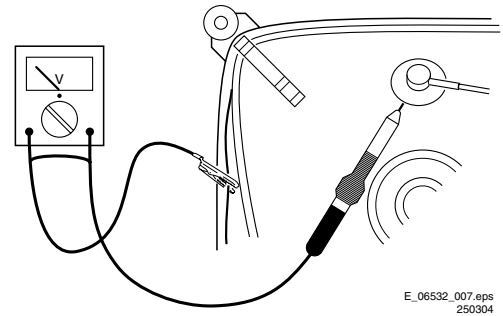

Figure 2-1 Discharge picture tube

- All ICs and many other semiconductors are susceptible to electrostatic discharges (ESD **▲**). Careless handling during repair can reduce life drastically. Make sure that, during repair, you are connected with the same potential as the mass of the set by a wristband with resistance. Keep components and tools also at this same potential. Available ESD protection equipment:
  - Complete kit ESD3 (small tablemat, wristband, connection box, extension cable and earth cable) 4822 310 10671.
  - Wristband tester 4822 344 13999.
- Be careful during measurements in the high voltage section.
- Never replace modules or other components while the unit is switched "on".
- When you align the set, use plastic rather than metal tools. This will prevent any short circuits and prevents circuits from becoming unstable.

### 2.4 Notes

#### 2.4.1 General

- Measure the voltages and waveforms with regard to the chassis (= tuner) ground ( $\perp$ ), or hot ground ( $\downarrow$ ), depending on the tested area of circuitry. The voltages and waveforms shown in the diagrams are indicative. Measure them in the Service Default Mode (see chapter 5) with a color bar signal and stereo sound (L: 3 kHz, R: 1 kHz unless stated otherwise) and picture carrier at 475.25 MHz for PAL, or 61.25 MHz for NTSC (channel 3).
- Where necessary, measure the waveforms and voltages with  $\square$  and without  $\square$  aerial signal. Measure the voltages in the power supply section both in normal operation ( $\textcircled{1}$ ) and in stand-by ( $\textcircled{2}$ ). These values are indicated by means of the appropriate symbols.
- The semiconductors indicated in the circuit diagram and in the parts lists, are interchangeable per position with the

semiconductors in the unit, irrespective of the type indication on these semiconductors.

- Manufactured under license from Dolby Laboratories. "Dolby", "Pro Logic" and the "double-D symbol", are trademarks of Dolby Laboratories.

#### 2.4.2 Schematic Notes

- All resistor values are in ohms, and the value multiplier is often used to indicate the decimal point location (e.g. 2K2 indicates 2.2 kohm).
- Resistor values with no multiplier may be indicated with either an "E" or an "R" (e.g. 220E or 220R indicates 220 ohm).
- All capacitor values are given in micro-farads ( $\mu = \times 10^{-6}$ ), nano-farads ( $n = \times 10^{-9}$ ), or pico-farads ( $p = \times 10^{-12}$ ).
- Capacitor values may also use the value multiplier as the decimal point indication (e.g. 2p2 indicates 2.2 pF).
- An "asterisk" (\*) indicates component usage varies. Refer to the diversity tables for the correct values.
- The correct component values are listed in the Spare Parts List. Therefore, always check this list when there is any doubt.

#### 2.4.3 Rework on BGA (Ball Grid Array) ICs

##### General

Although (LF)BGA assembly yields are very high, there may still be a requirement for component rework. By rework, we mean the process of removing the component from the PWB and replacing it with a new component. If an (LF)BGA is removed from a PWB, the solder balls of the component are deformed drastically so the removed (LF)BGA has to be discarded.

##### Device Removal

As is the case with any component that is being removed, it is essential when removing an (LF)BGA, that the board, tracks, solder lands, or surrounding components are not damaged. To remove an (LF)BGA, the board must be uniformly heated to a temperature close to the reflow soldering temperature. A uniform temperature reduces the risk of warping the PWB. To do this, we recommend that the board is heated until it is certain that all the joints are molten. Then carefully pull the component off the board with a vacuum nozzle. For the appropriate temperature profiles, see the IC data sheet.

##### Area Preparation

When the component has been removed, the vacant IC area must be cleaned before replacing the (LF)BGA.

Removing an IC often leaves varying amounts of solder on the mounting lands. This excessive solder can be removed with either a solder sucker or solder wick. The remaining flux can be removed with a brush and cleaning agent.

After the board is properly cleaned and inspected, apply flux on the solder lands and on the connection balls of the (LF)BGA.

**Note:** Do not apply solder paste, as this has been shown to result in problems during re-soldering.

##### Device Replacement

The last step in the repair process is to solder the new component on the board. Ideally, the (LF)BGA should be aligned under a microscope or magnifying glass. If this is not possible, try to align the (LF)BGA with any board markers. So as not to damage neighboring components, it may be necessary to reduce some temperatures and times.

##### More Information

For more information on how to handle BGA devices, visit this URL: [www.atyourservice.ce.philips.com](http://www.atyourservice.ce.philips.com) (needs subscription, not available for all regions). After login, select "Magazine", then go to "Repair downloads". Here you will find Information on how to deal with BGA-ICs.

#### 2.4.4 Lead-free Solder

Philips CE is producing lead-free sets (PBF) from 1.1.2005 onwards.

**Identification:** The bottom line of a type plate gives a 14-digit serial number. Digits 5 and 6 refer to the production year, digits 7 and 8 refer to production week (in example below it is 1991 week 18).

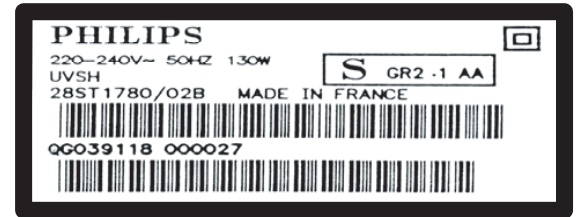

E\_06532\_024.eps  
230205

Figure 2-2 Serial number example

Regardless of the special lead-free logo (which is not always indicated), one must treat all sets from this date onwards according to the rules as described below.

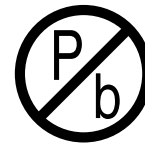

Figure 2-3 Lead-free logo

Due to lead-free technology some rules have to be respected by the workshop during a repair:

- Use only lead-free soldering tin Philips SAC305 with order code 0622 149 00106. If lead-free solder paste is required, please contact the manufacturer of your soldering equipment. In general, use of solder paste within workshops should be avoided because paste is not easy to store and to handle.
- Use only adequate solder tools applicable for lead-free soldering tin. The solder tool must be able:
  - To reach a solder-tip temperature of at least 400°C.
  - To stabilize the adjusted temperature at the solder-tip.
  - To exchange solder-tips for different applications.
- Adjust your solder tool so that a temperature of around 360°C - 380°C is reached and stabilized at the solder joint. Heating time of the solder-joint should not exceed ~ 4 sec. Avoid temperatures above 400°C, otherwise wear-out of tips will increase drastically and flux-fluid will be destroyed. To avoid wear-out of tips, switch "off" unused equipment or reduce heat.
- Mix of lead-free soldering tin/parts with leaded soldering tin/parts is possible but PHILIPS recommends strongly to **avoid** mixed regimes. If this cannot be avoided, carefully clean the solder-joint from old tin and re-solder with new tin.
- Use only original spare-parts listed in the Service-Manuals. Not listed standard material (commodities) has to be purchased at external companies.
- Special information for lead-free BGA ICs: these ICs will be delivered in so-called "dry-packaging" to protect the IC against moisture. This packaging may only be opened shortly before it is used (soldered). Otherwise the body of the IC gets "wet" inside and during the heating time the structure of the IC will be destroyed due to high (steam-) pressure inside the body. If the packaging was opened before usage, the IC has to be heated up for some hours (around 90°C) for drying (think of ESD-protection!).  
**Do not re-use BGAs at all!**

- For sets produced before 1.1.2005, containing leaded soldering tin and components, all needed spare parts will be available till the end of the service period. For the repair of such sets nothing changes.

In case of doubt whether the board is lead-free or not (or with mixed technologies), you can use the following method:

- Always use the highest temperature to solder, when using SAC305 (see also instructions below).
- De-solder thoroughly (clean solder joints to avoid mix of two alloys).

**Caution:** For BGA-ICs, you **must** use the correct temperature-profile, which is coupled to the 12NC. For an overview of these profiles, visit the website [www.atyourservice.ce.philips.com](http://www.atyourservice.ce.philips.com) (needs subscription, but is not available for all regions)

You will find this and more technical information within the "Magazine", chapter "Repair downloads".

For additional questions please contact your local repair help desk.

#### 2.4.5 Alternative BOM identification

In September 2003, Philips CE introduced a change in the way the serial number (or production number, see Figure 2-2) is composed. From this date on, the **third digit** in the serial number (example: AG2B0335000001) indicates the number of the alternative BOM (Bill of Materials used for producing the specific model of TV set). It is possible that the same TV model on the market is produced with e.g. two different types of displays, coming from two different O.E.M.s.

By looking at the third digit of the serial number, the service technician can see if there is more than one type of B.O.M. used in the production of the TV set he is working with. He can then consult the At Your Service Web site, where he can type in the Commercial Type Version Number of the TV set (e.g. 28PW9515/12), after which a screen will appear that gives information about the number of alternative B.O.M.s used. If the third digit of the serial number contains the number 1 (example: AG1B0335000001), then there is only one B.O.M. version of the TV set on the market. If the third digit is a 2 (example: AG2B0335000001), then there are two different B.O.M.s. **Information about this is important for ordering the correct spare parts!**

For the third digit, the numbers 1...9 and the characters A...Z can be used, so in total: 9 plus 26 = 35 different B.O.M.s can be indicated by the third digit of the serial number.

#### 2.4.6 Practical Service Precautions

- **It makes sense to avoid exposure to electrical shock.** While some sources are expected to have a possible dangerous impact, others of quite high potential are of limited current and are sometimes held in less regard.
- **Always respect voltages.** While some may not be dangerous in themselves, they can cause unexpected reactions that are best avoided. Before reaching into a powered TV set, it is best to test the high voltage insulation. It is easy to do, and is a good service precaution.

### 3. Directions for Use

You can download this information from the following websites:

<http://www.philips.com/support>

<http://www.p4c.philips.com>

## 4. Mechanical Instructions

### Index of this chapter:

- 4.1 Rear Cover Removal
- 4.2 Service Position Main Panel
- 4.3 Rear Cover Mounting

### 4.1 Rear Cover Removal

1. Remove all fixation screws of the rear cover.
2. Now pull the rear cover in backward direction to remove it.

### 4.2 Service Position Main Panel

1. Disconnect the strain relief of the AC power cord.
2. Remove the main panel, by pushing the two center clips outward [1]. At the same time pull the panel away from the CRT [2].
3. If necessary disconnect the degaussing coil by removing the cable from (red) connector 0212.
4. Move the panel somewhat to the left and flip it 90 degrees [3], with the components towards the CRT.

### 4.3 Rear Cover Mounting

Before you mount the rear cover, perform the following checks:

1. Check whether the mains cord is mounted correctly in its guiding brackets.
2. Re-place the strain relief of the AC power cord into the cabinet.
3. Check whether all cables are replaced in their original position

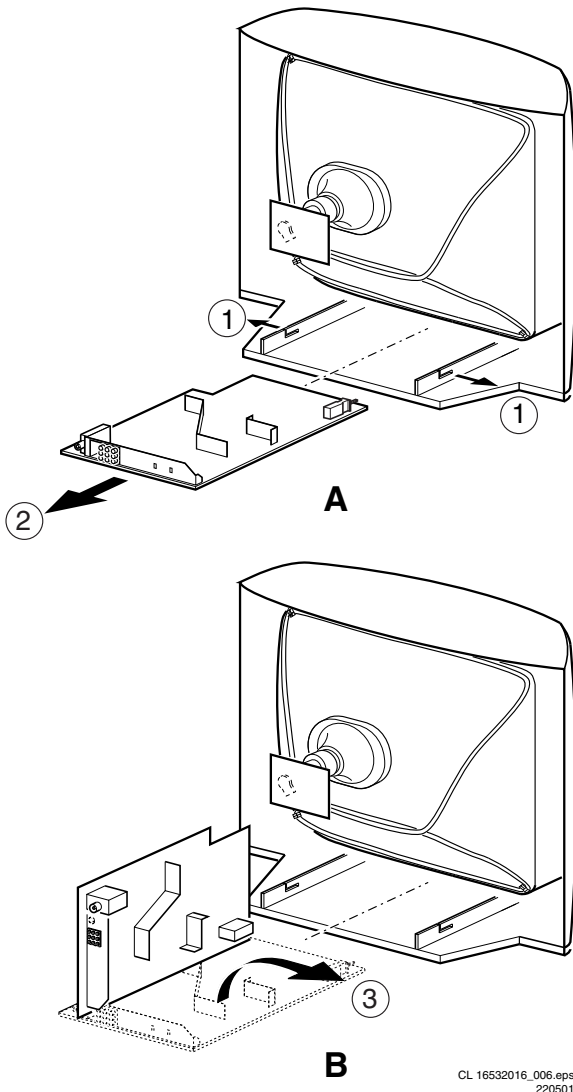

CL 16532016\_006.eps  
220501

Figure 4-1 Service Position

# 5. Service Modes, Error Codes, and Fault Finding

**Index of this chapter:**

- 5.1 Test Points
- 5.2 Service Modes
- 5.3 Problems and Solving Tips
- 5.4 Service Tools
- 5.5 The Blinking LED Procedure
- 5.6 Protections
- 5.7 Repair Tips

## 5.1 Test Points

This chassis is equipped with test points in the service printing. In the schematics test points are identified with a rectangle box around Fxxx or lxxx. On the PCB, test points are specifically mentioned in the service manual as "half moons" with a dot in the center.

**Table 5-1 Test Point Overview**

TEST POINT	CIRCUIT	DIAGRAM
Fxxx, lxxx	POWER SUPPLY	A1
Fxxx, lxxx	Deflection	A2
Fxxx, lxxx	TUNER & IF	A3
Fxxx, lxxx	VIDEO PROCESSING	A4
Fxxx, lxxx	AUDIO PROCESSING	A5
Fxxx, lxxx	AUDIO AMPLIFIER + MONO SOUND PROCESSING	A6
Fxxx, lxxx	FRONT IO + FRONT CONTROL + HEADPHONE	A7
Fxxx, lxxx	DVD POWER SUPPLY	A9
Fxxx, lxxx	CRT PANEL	B1

Perform measurements under the following conditions:

- Service Default Alignment Mode.
- Video: color bar signal.
- Audio: 3 kHz left, 1 kHz right.

## 5.2 Service Modes

Service Default Alignment Mode (SDAM) offers several features for the service technician.

There is also the option of using ComPair, a hardware interface between a computer (see requirements) and the TV chassis. It offers the ability of structured trouble shooting, error code reading and software version readout for all chassis. Requirements: To run ComPair on a computer (laptop or desktop) requires, as a minimum, a 486 processor, Windows 3.1 and a CD-ROM drive. A Pentium Processor and Windows 95/98 are however preferred (see also paragraph 5.4).

**Table 5-2 SW Cluster**

SW Cluster	Software mane	UOC type	UOC Diversity	Special Features
L3SUS1	L03US1 x.y	TDA9377	55K ROM Size	Stereo
L3SUS2	L03US2 x.y	TDA9377	55K ROM Size	Magnavox Stereo

Abbreviations in Software name: U = Nafta, S = Stereo.

- **AAABCD-X.Y.** This is the software identification of the

### 5.2.1 Service Default Alignment Mode (SDAM)

**Purpose**

- To change option settings.
- To create a predefined setting to get the same measurement results as given in this manual.
- To display / clear the error code buffer.
- To override SW protections.
- To perform alignments.
- To start the blinking LED procedure.

**Specifications**

- Tuning frequency: 61.25 MHz (channel 3) for NTSC-sets (Nafta).
- Color system: NTSC-M.
- All picture settings at 50 % (brightness, color contrast, hue).
- Bass, treble and balance at 50 %; volume at 25 %.
- All service-unfriendly modes (if present) are disabled, like:
  - (Sleep) timer,
  - Child/parental lock,
  - Blue mute,
  - Hotel/hospitality mode
  - Auto switch-off (when no "IDENT" video signal is received for 15 minutes),
  - Skip / blank of non-favorite presets / channels,
  - Auto store of personal presets,
  - Auto user menu time-out.
- Operation hours counter.
- Software version.
- Option settings.
- Error buffer reading and erasing.
- Software alignments.

**How to enter SDAM**

Use one of the following methods:

- Use a standard customer RC-transmitter and key in the code 062596 directly followed by the "M" (menu) button or
- Short jumper wires 9257 and pin 4 of 7200 on the mono carrier (see Fig. 8-1) and apply AC power. Then press the power button (remove the short after start-up).
- Caution: Entering SDAM by shorten wires 9257 and pin 4 of 7200 will override the +8V-protection. Do this only for a short period. When doing this, the service-technician must know exactly what he is doing, as it could lead to damaging the set.
- Or via ComPair.

After entering SDAM, the following screen is visible, with S at the upper right side for recognition.

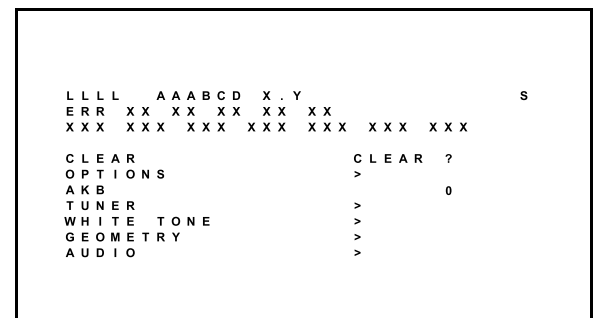

CL 36532044\_033.eps  
130603

**Figure 5-1 SDAM Menu**

- **LLLL.** This is the operation hours counter. It counts the normal operation hours, not the standby hours. main micro controller:

- A = the project name (L03).
  - B = the region: E= Europe, A= Asia Pacific, U= NAFTA, L= LATAM.
  - C = the feature of software diversity: N = stereo non-DBX, S = stereo dBx, M = mono, D = DVD
  - D = the language cluster number:
  - X = the main software version number.
  - Y = the sub software version number.
  - **S.** Indication of the actual mode. S= SDAM= Service Default Alignment mode.
  - **Error buffers.** Five errors possible.
  - **Option bytes.** Seven codes possible.
  - **Clear.** Erase the contents of the error buffer. Select the CLEAR menu item and press the CURSOR RIGHT key. The content of the error buffer is cleared.
  - **Options.** To set the Option Bytes. See chapter 8.3.1 for a detailed description.
  - **AKB.** Disable (0) or enable (1) the “black current loop” (AKB = Auto Kine Bias).
  - **Tuner.** To align the Tuner. See chapter 8.3.2 for a detailed description.
  - **White Tone.** To align the White Tone. See chapter 8.3.3 for a detailed description.
  - **Geometry.** To align the set geometry. See chapter 8.3.4 for a detailed description.
  - **Audio. Use default value (Stereo set only),** align when necessary. See chapter 8.3.x for a detailed description.
- <<<<<<<

#### How to navigate

- In SDAM, select menu items with the CURSOR UP/DOWN key on the remote control transmitter. The selected item will be highlighted. When not all menu items fit on the screen, move the CURSOR UP/DOWN key to display the next / previous menu items.
- With the CURSOR LEFT/RIGHT keys, it is possible to:
  - Activate the selected menu item.
  - Change the value of the selected menu item.
  - Activate the selected submenu.
- When you press the MENU button twice, the set will switch to the normal user menus (with the SDAM mode still active in the background). To return to the SDAM menu press the OSD / STATUS button.
- When you press the MENU key in a submenu, you will return to the previous menu.

#### How to store settings

To store settings, leave the SDAM mode with the Standby button on the remote.

#### How to exit

Switch the set to STANDBY by pressing the power button on the remote control (if you switch the set 'off' by removing the AC power, the set will return in SDAM when AC power is re-applied). The error buffer is **not** cleared.

## 5.3 Problems and Solving Tips

### 5.3.1 Picture Problems

**Note:** Below described problems are all related to the TV settings. The procedures to change the value (or status) of the different settings are described.

#### No colors / noise in picture

1. Press the MENU button on the remote control.
2. Select the INSTALLATION sub menu.
3. Select and change the SYSTEM setting until picture and sound are correct.
4. Select the STORE menu item.

#### Colors not correct / unstable picture

1. Press the MENU button on the remote control.

2. Select the INSTALLATION sub menu.
3. Select and change the SYSTEM setting until picture and sound are correct.
4. Select the STORE menu item.

#### Picture too dark or too bright

Increase / decrease the BRIGHTNESS and / or the CONTRAST value when:

- The picture improves after you have pressed the “Smart Picture” button on the remote control.
  - The picture improves after you have switched on the Customer Service Mode
- The new “Personal” preference value is automatically stored.

#### White line around picture elements and text

Decrease the SHARPNESS value when:

- The picture improves after you have pressed the “Smart Picture” button on the remote control.
- The new “Personal” preference value is automatically stored.

#### Snowy picture

- No or bad antenna signal. Connect a proper antenna signal.
- Antenna not connected. Connect the antenna.
- No channel / pre-set is stored at this program number. Go to the INSTALL menu and store a proper channel at this program number.
- The tuner is faulty (in this case the CODES line will contain error number 10). Check the tuner and replace / repair if necessary.

#### Snowy picture and/or unstable picture

- A scrambled or decoded signal is received.

#### Black and white picture

Increase the COLOR value when:

- The picture improves after you have pressed the “Smart Picture” button on the remote control.
- The new “Personal” preference value is automatically stored.

#### Menu text not sharp enough

Decrease the CONTRAST value when:

- The picture improves after you have pressed the “Smart Picture” button on the remote control.
- The new “Personal” preference value is automatically stored.

## 5.3.2 Sound Problems

#### No sound or sound too loud (after channel change / switching on)

Increase / decrease the VOLUME level.

Press the Smart Sound button repeatedly to access 4 different types of sound settings and choose your desired setting.

## 5.4 Service Tools

### 5.4.1 ComPair

#### Introduction

ComPair (Computer Aided Repair) is a service tool for Philips Consumer Electronics products. ComPair is a further development on the European DST (service remote control), which allows faster and more accurate diagnostics. ComPair has three big advantages:

1. ComPair helps you to quickly get an understanding on how to repair the chassis in a short time by guiding you systematically through the repair procedures.
2. ComPair allows very detailed diagnostics (on I<sup>2</sup>C level) and is therefore capable of accurately indicating problem areas. You do not have to know anything about I<sup>2</sup>C commands yourself because ComPair takes care of this.

- ComPair speeds up the repair time since it can automatically communicate with the chassis (when the microprocessor is working) and all repair information is directly available. When ComPair is installed together with the Force/SearchMan electronic manual of the defective chassis, schematics and PWBs are only a mouse click away.

### Specifications

ComPair consists of a Windows based fault finding program and an interface box between PC and the (defective) product. The ComPair interface box is connected to the PC via a serial (or RS-232) cable.

For this chassis, the ComPair interface box and the TV communicate via a bi-directional service cable via the service connector(s).

The ComPair fault finding program is able to determine the problem of the defective television. ComPair can gather diagnostic information in two ways:

- Automatically (by communicating with the television): ComPair can automatically read out the contents of the entire error buffer. Diagnosis is done on I<sup>2</sup>C/UART level. ComPair can access the I<sup>2</sup>C/UART bus of the television. ComPair can send and receive I<sup>2</sup>C/UART commands to the microcontroller of the television. In this way, it is possible for ComPair to communicate (read and write) to devices on the I<sup>2</sup>C/UART buses of the TV-set.
- Manually (by asking questions to you): Automatic diagnosis is only possible if the microcontroller of the television is working correctly and only to a certain extent. When this is not the case, ComPair will guide you through the fault finding tree by asking you questions (e.g. *Does the screen give a picture? Click on the correct answer: YES / NO*) and showing you examples (e.g. *Measure test-point 17 and click on the correct oscillogram you see on the oscilloscope*). You can answer by clicking on a link (e.g. *text or a waveform picture*) that will bring you to the next step in the fault finding process.

By a combination of automatic diagnostics and an interactive question / answer procedure, ComPair will enable you to find most problems in a fast and effective way.

### How to Connect

This is described in the chassis fault finding database in ComPair.

**Caution:** It is compulsory to connect the TV to the PC as shown in the picture below (with the ComPair interface in between), as the ComPair interface acts as a level shifter. If one connects the TV directly to the PC (via UART), ICs will be blown!

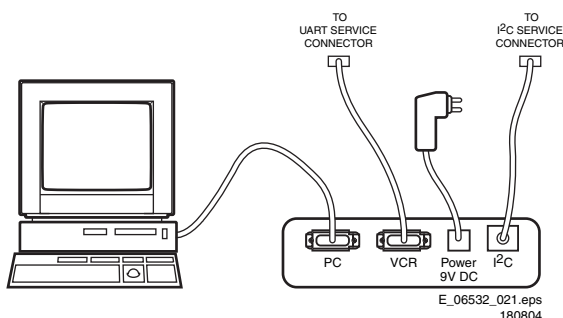

Figure 5-2 ComPair interface connection

### How to Order

ComPair order codes (US):

- ComPair Software: ST4191.
- ComPair Interface Box: 4822 727 21631.
- AC Adapter: T405-ND.

- ComPair Quick Start Guide: ST4190.
- ComPair interface extension cable: 3139 131 03791.
- ComPair UART interface cable: 3122 785 90630.

**Note:** If you encounter any problems, contact your local support desk.

## 5.5 The Blinking LED Procedure

Via this procedure, you can make the contents of the error buffer visible via the front LED. This is especially useful when there is no picture.

When the SDAM is entered, the LED will blink the contents of the error-buffer.

- n short blinks (n = 1 - 14),
- When all the error-codes are displayed, the sequence finishes with a LED blink of 3 s,
- The sequence starts again.

**Example** of error buffer: 12 9 6 0 0

After entering SDAM:

- 12 short blinks followed by a pause of 3 s,
- 9 short blinks followed by a pause of 3 s,
- 6 short blinks followed by a pause of 3 s,
- 1 long blink of 3 s to finish the sequence,
- the sequence starts again.

## 5.6 Protections

If a fault situation is detected an error code will be generated and if necessary the set will be put in the protection mode. Blinking of the red LED at a frequency of 3 Hz indicates the protection mode. In some error cases, the microprocessor does not put the set in the protection mode. The error codes of the error buffer can be read via the service menu (SDAM), the blinking LED procedure or via ComPair.

To get a quick diagnosis the chassis has one service modes implemented:

- The Service Default Alignment Mode (SDAM). Start-up of the set in a predefined way and adjustment of the set via a menu and with the help of test patterns.

## 5.7 Repair Tips

Below some failure symptoms are given, followed by a repair tip.

- Set is dead and makes hiccupping sound.** "Main Supply" is available. Hiccupping stops when de-soldering L5563, meaning that problem is in the "Main Supply" line. No output voltages at LOT, no horizontal deflection. Reason: line transistor 7421 is defective.
- Set is dead, and makes no sound.** Check power supply IC 7520. Result: voltage at pins 2, 6, 7, 9 and 11 are about 180 V and pin 14 is 0 V. The reason why the voltage on these pins is so high is because the output driver (pin 11) has an open load. That is why MOSFET 7521 is not able to switch. Reason: feedback resistor 3523 is defective. **Caution:** be careful measuring on the gate of 7521; circuitry is very high ohmic and can easily be damaged!
- Set is in hiccup mode and shuts down after 8 s.** Blinking LED (set in SDM mode) indicates error 5. As it is unlikely that the "POR" and "+8V protection" happen at the same time, measure the "+8V". If this voltage is missing, check transistor 7491 & 7496.
- Set is non-stop in hiccup mode.** Set is in over current mode; check the secondary sensing (opto coupler 7515) and the "Main Supply" voltage. Signal "STDBY\_CON" must be logic low under normal operation conditions and goes to high (3.3 V) under standby and fault conditions.

- **Set turns on, but without picture and sound.** The screen shows snow, but OSD and other menus are okay. Blinking LED procedure indicates error 11, so problem is expected in the tuner (pos. 1000). Check presence of supply voltages. As "Vlotaux+5V" at pin 5 and 7 are okay, "VT\_supply" at pin 9 is missing. Conclusion: resistors 3449 & 3450 are defective.

# 6. Block Diagrams, Test Point Overviews, and Waveforms

## Block Diagram

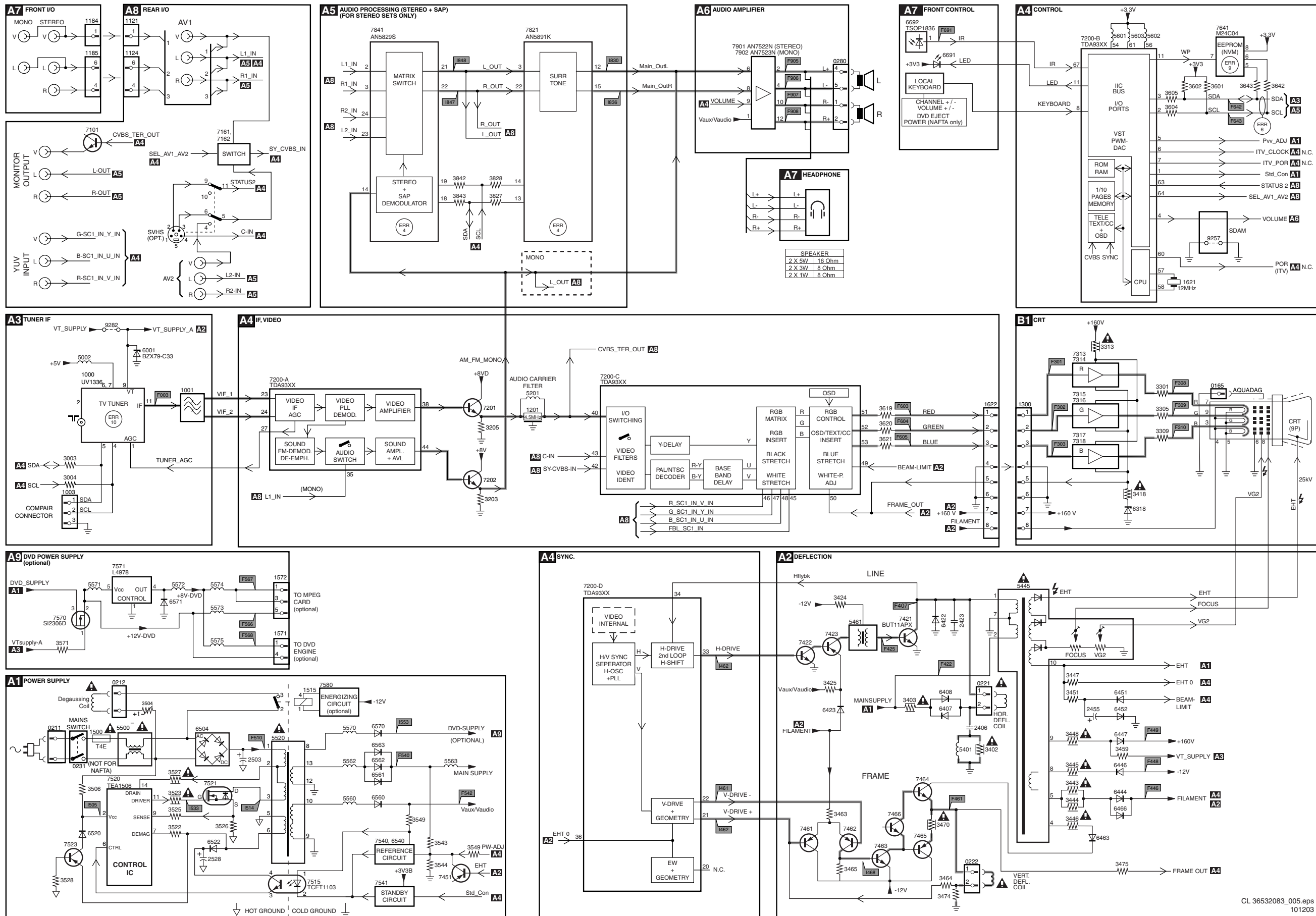

# I<sup>2</sup>C and Supply Voltage Overview

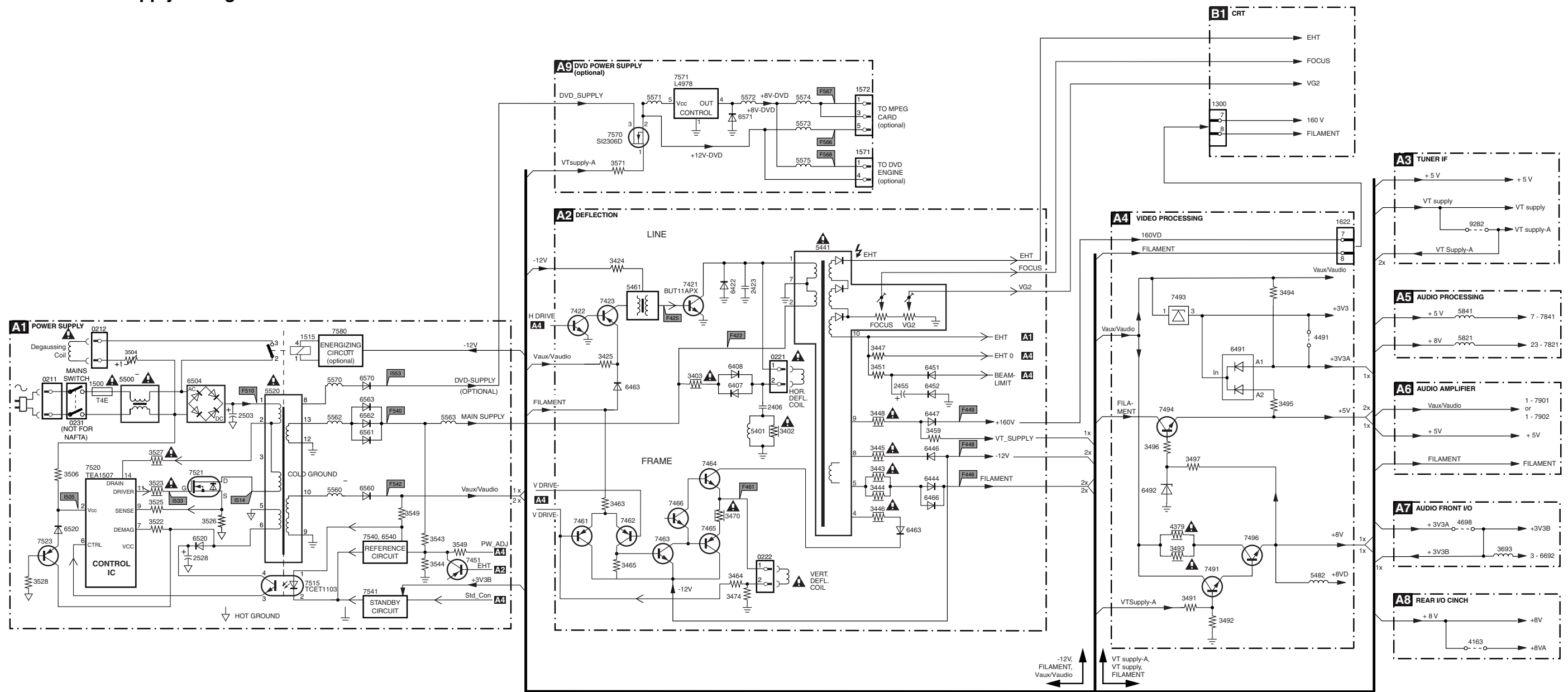

## ERROR CODE LIST

Error	Device	Error description	Check item	Diagram
0	Not applicable	No Error	-	-
1	Not applicable	X-Ray Protection (USA)	-	-
2	Not applicable	Horizontal Protection	7421, 7422, 7423	A2
3	Not applicable	Vertical Protection	7461, 7462, 7463, 7464, 7465, 7466	A2
4	AN5891K & AN5829S	Tone control & Audio processor I2C identification error	7821 (tone IC), 7841 (Stereo/Sap)	A5
5	TDA93XX	POR 3.3V / 8V Protection	7200, 7541, 7491, 7493, 7496	A4, A1
6	I2C bus	General I2C bus error	7200, 3604, 3605	A4
7	Not applicable	-	-	-
8	Not applicable	E/W Protection (Large Screen)	-	-
9	M24C16	NVM I2C identification error	7641, 3641, 3642, 3643	A4
10	Tuner	Tuner I2C identification error	1000, 3003, 3004	A3
11	Not applicable	Black current loop protection	3313, 7307, 7308, 7309, 7310, 7311, 7312, 7313, 7314, 7315, 7316, 7317, 7318, CRT	B1
12	Not applicable	MAP I2C identification error (USA)	-	-
13	Not applicable	VC I2C identification error (Eu)	-	-
14	Not applicable	DVD I2C identification error	-	-

## I2C BUS INTERCONNECTION DIAGRAM

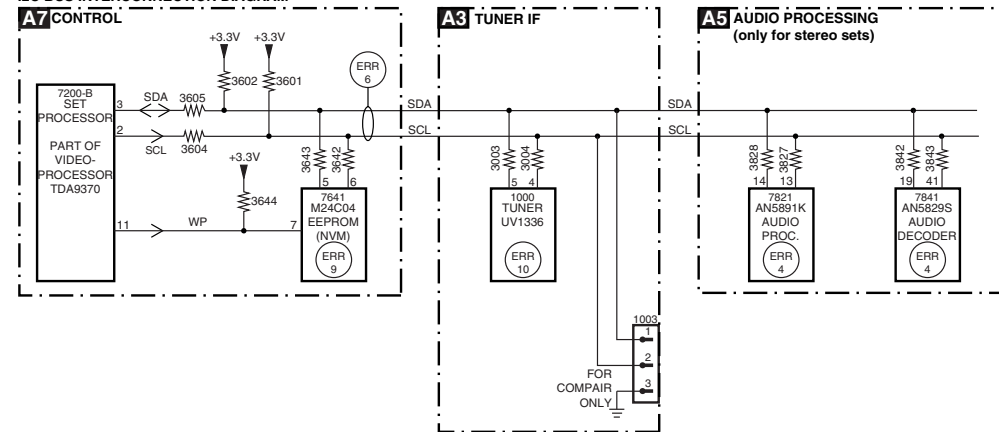

### Testpoint Overview Mono Carrier and CRT Panel

MONO CARRIER TRACK SIDE VIEW

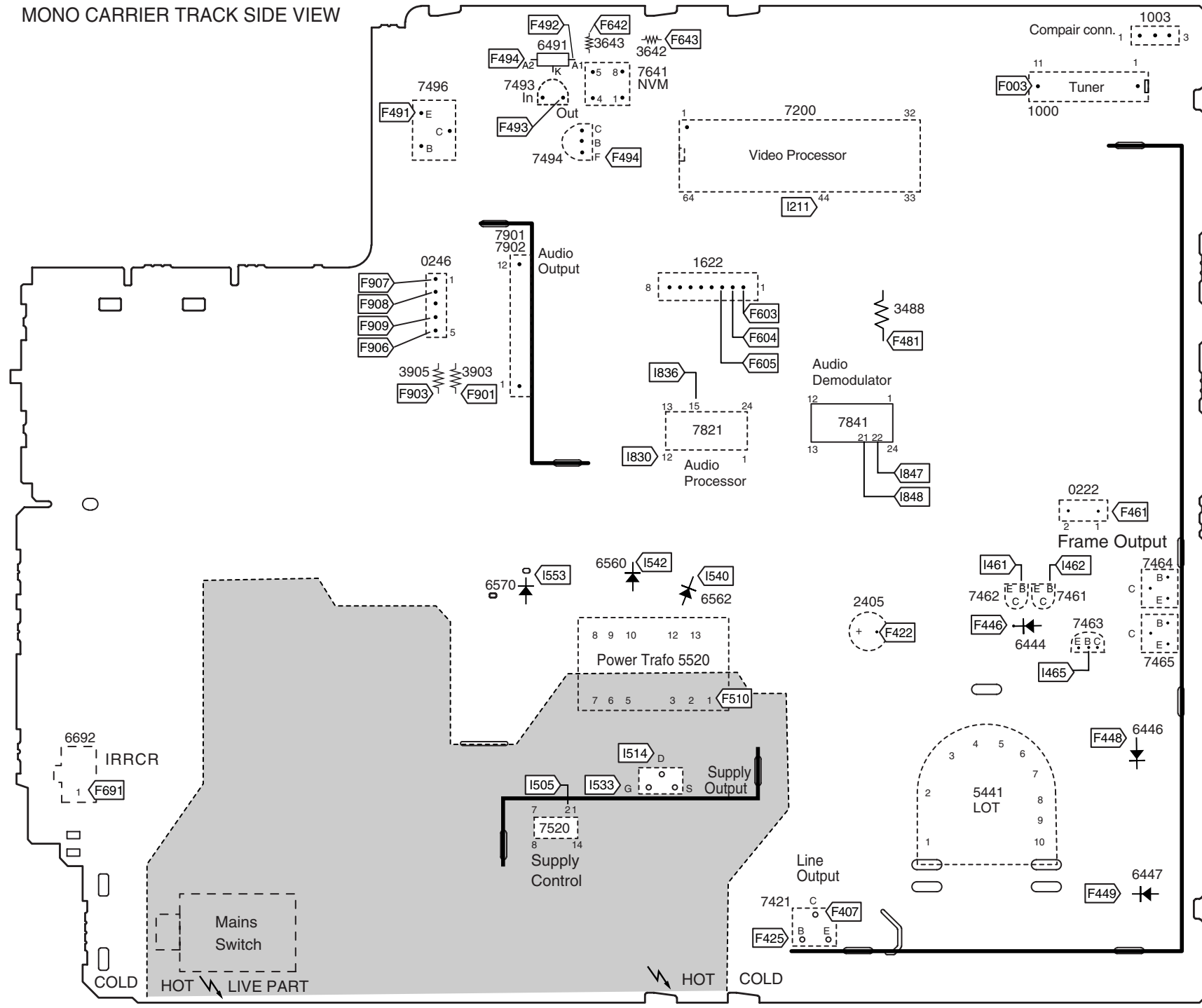

CRT TRACK SIDE VIEW

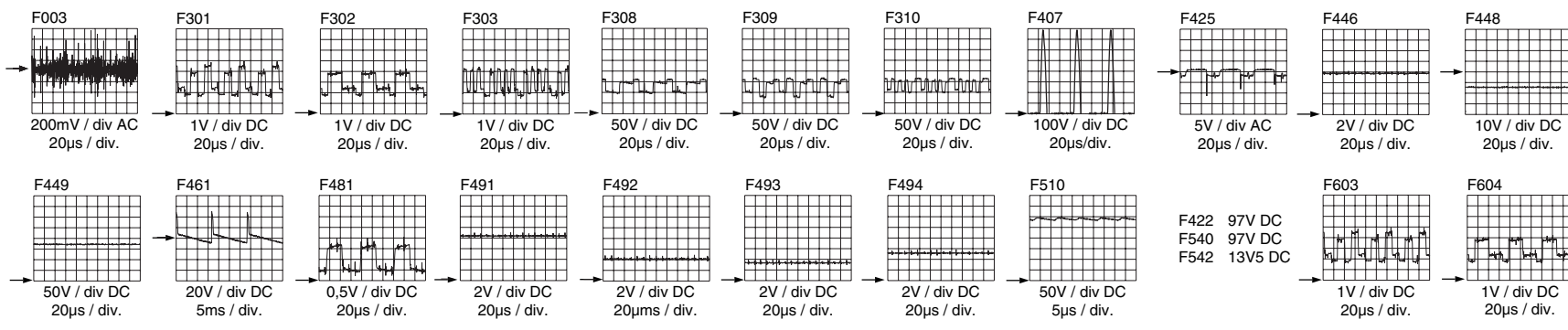
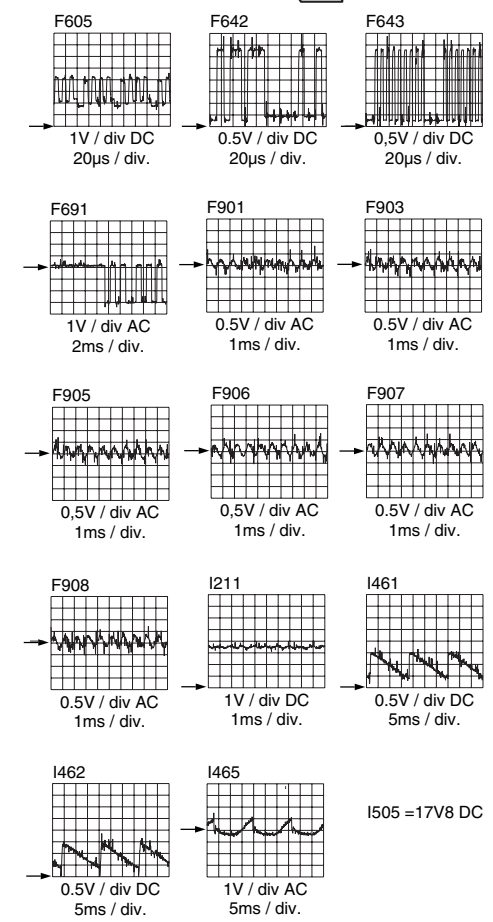
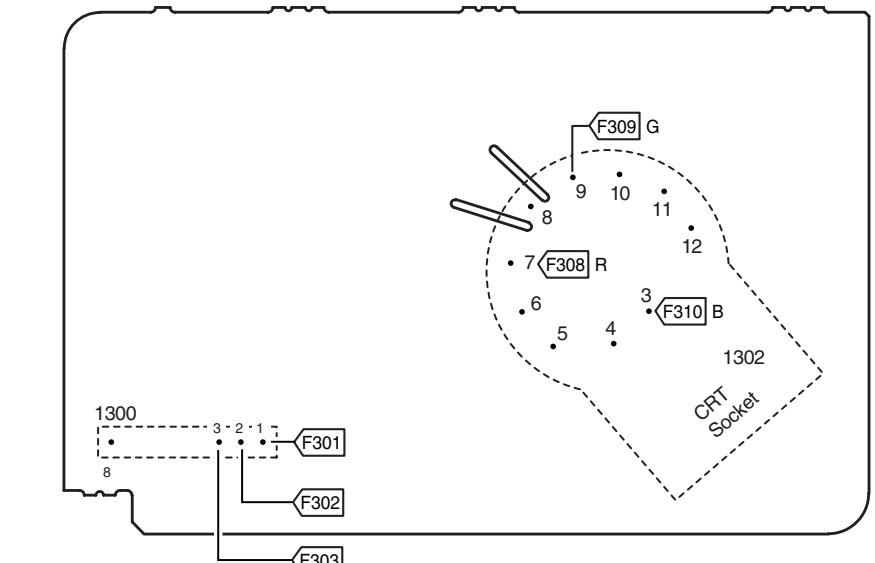

# 7. Circuit Diagrams and PWB Layouts

## Mono Carrier: Power Supply

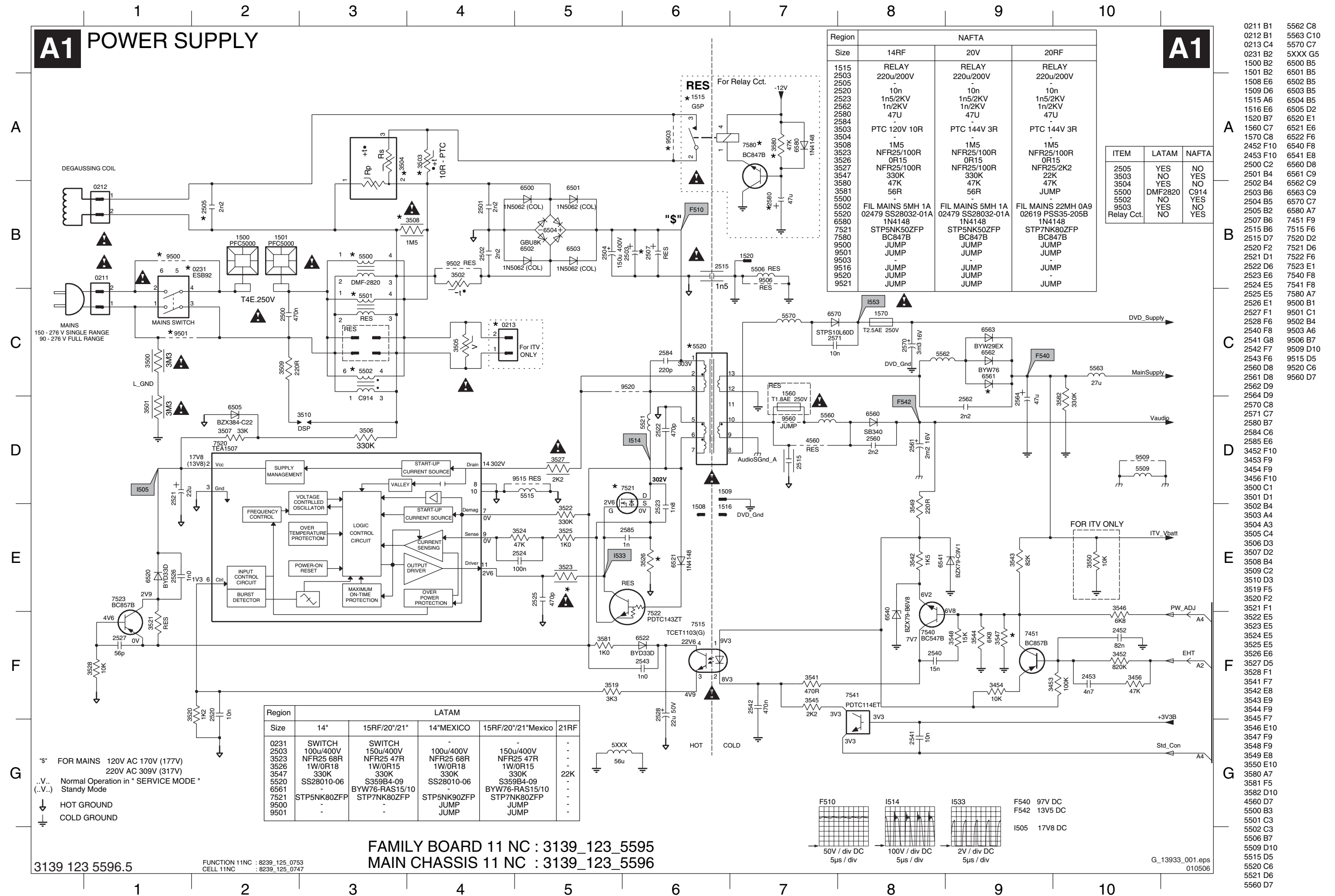

Mono Carrier: Deflection

A2 DEFLECTION

A2

Line Deflection

Frame Deflection

Region	LATAM			
	14" LPD	15RF CPT	20" LPD	21"FSQ LPD
Size Tube				
2406	560n/250V	380n/250V	680n/250V	560n/250V
2408	13n/1K6V	13n/1K6V	15n/1K6V	15n/1K6V
2423	1n/2KV	1n/2KV	1n/2KV	1n/2KV
2424	22n	15n	15n	33n
2441	22n	10n	22n	100n
2452	-	-	2n2	-
2453	-	-	-	470p/500V
2457	-	-	-	NFR25H 2K2
3402	-	NFR25H 2K2	-	NFR25H 2K2
3441	47K	10K	10K	56K
3442	150K	150K	150K	100K
3447	220K	100K	100K	220K
3451	680R	8K2	1K8	8K2
3455	470R	2K2	2K2	2K2
3456	100K	47K	47K	47K
3460	1M	1M	1M	-
3646	68u/LHL08	00425/82u	33u/LHL08	00511/33u
5401	JF0501-19255	JF0501-19255	JF0501-19255	JF0501-19276
5402				
5441				

Region	LATAM			
	14" LPD	15RF CPT	20" LPD	21"FSQ LPD
Size Tube				
3473	4R7	2R2	3R3	3R3
3474	4R7	3R9	3R9	3R3

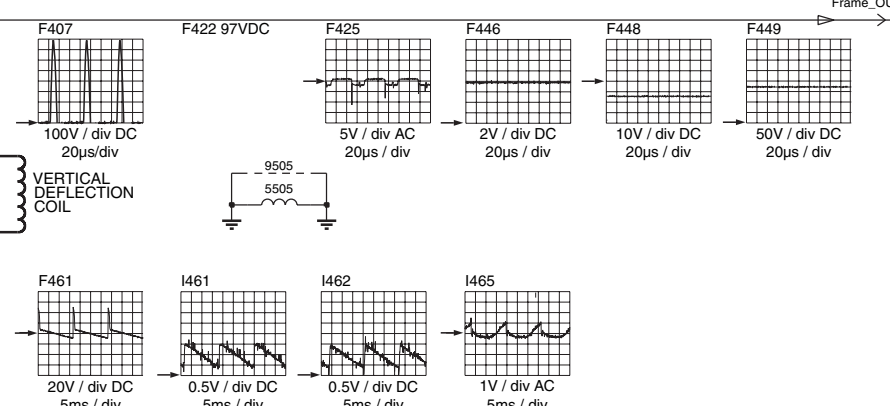
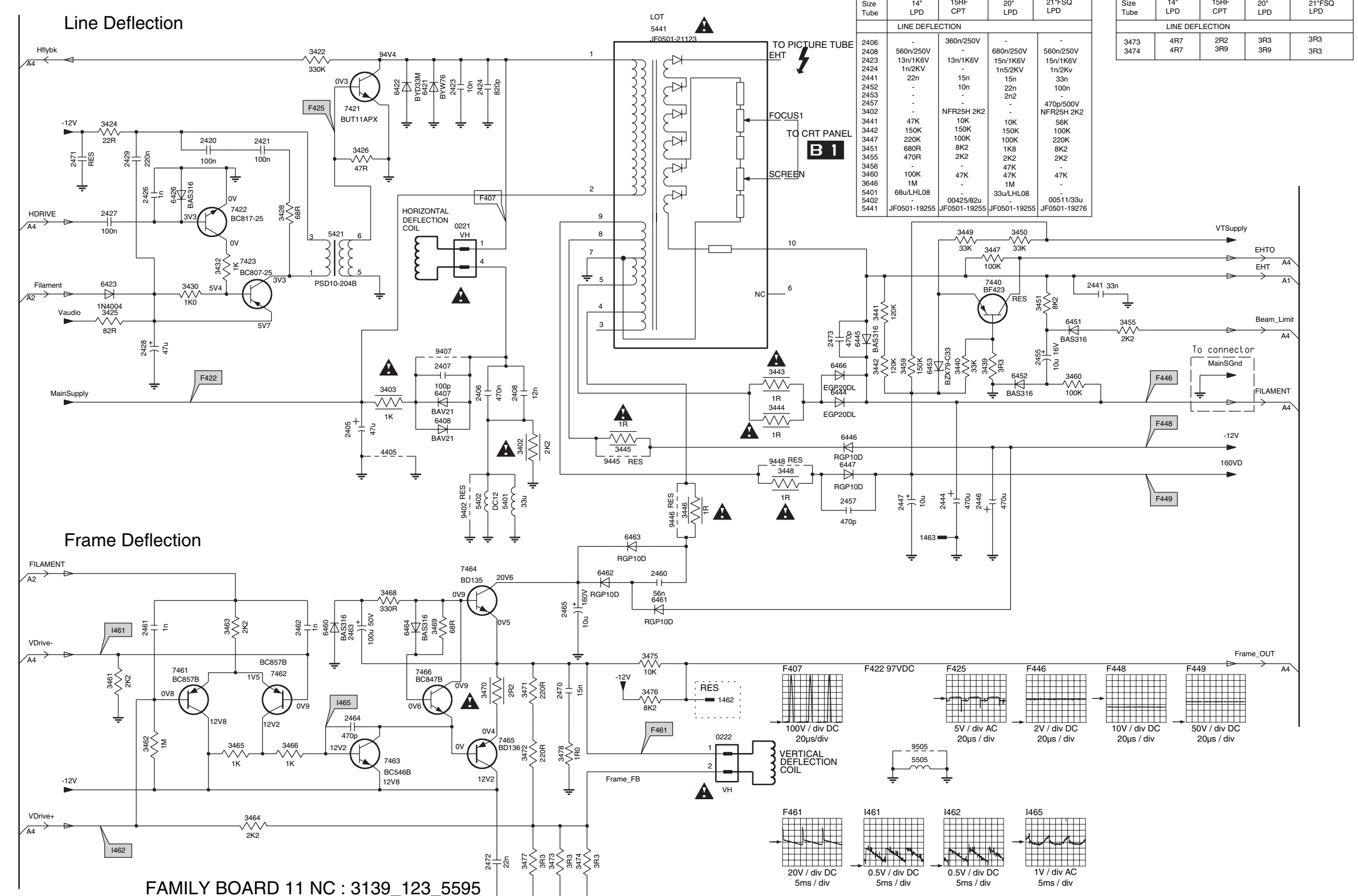

FAMILY BOARD 11 NC : 3139\_123\_5595  
 MAIN CHASSIS 11 NC : 3139\_123\_5596

3139 123 5596.5

G\_13933\_002.eps  
010506

- 0221 C4
- 0222 G6
- 1463 G7
- 2405 E4
- 2406 D5
- 2407 D4
- 2408 D5
- 2420 B2
- 2421 B3
- 2423 B4
- 2424 B5
- 2426 C2
- 2427 C2
- 2428 D2
- 2429 D2
- 2441 C9
- 2444 E8
- 2446 E9
- 2447 E8
- 2455 D9
- 2457 E7
- 2460 F6
- 2461 F2
- 2462 F3
- 2463 F4
- 2464 G4
- 2465 F5
- 2470 G5
- 2471 B1
- 2472 H5
- 2473 D7
- 3402 E5
- 3403 D4
- 3422 B3
- 3424 B2
- 3425 D2
- 3426 B4
- 3428 C3
- 3430 C2
- 3432 C3
- 3439 D9
- 3440 D8
- 3441 D8
- 3442 D8
- 3443 D7
- 3444 D7
- 3445 E6
- 3446 E6
- 3447 C9
- 3448 E7
- 3449 C8
- 3450 C9
- 3451 D9
- 3455 D10
- 3459 D8
- 3460 D9
- 3461 G2
- 3462 G2
- 3463 F3
- 3464 H3
- 3465 G3
- 3466 G3
- 3468 F4
- 3469 F4
- 3470 G5
- 3471 G5
- 3472 G5
- 3473 H5
- 3474 H5
- 3475 F6
- 3476 G6
- 3477 H5
- 3478 G5
- 4405 E4
- 5401 E5
- 5402 E5
- 5421 C3
- 5441 A6
- 5505 G8
- 6407 D4
- 6408 E4
- 6421 B4
- 6422 B4
- 6423 C2
- 6426 C2
- 6444 D7
- 6445 D8
- 6446 E7
- 6447 E7
- 6451 D9
- 6452 D9
- 6453 D8
- 6460 F3
- 6461 F6
- 6462 F6
- 6463 E6
- 6464 F4
- 6466 D7
- 7421 B3
- 7422 C3
- 7423 C3
- 7440 C9
- 7461 G2
- 7462 G3
- 7463 G3
- 7464 G2
- 7466 G2
- 9402 E4
- 9407 D4
- 9445 E6
- 9446 E6
- 9448 E7
- 9505 G8

Mono Carrier: Tuner IF

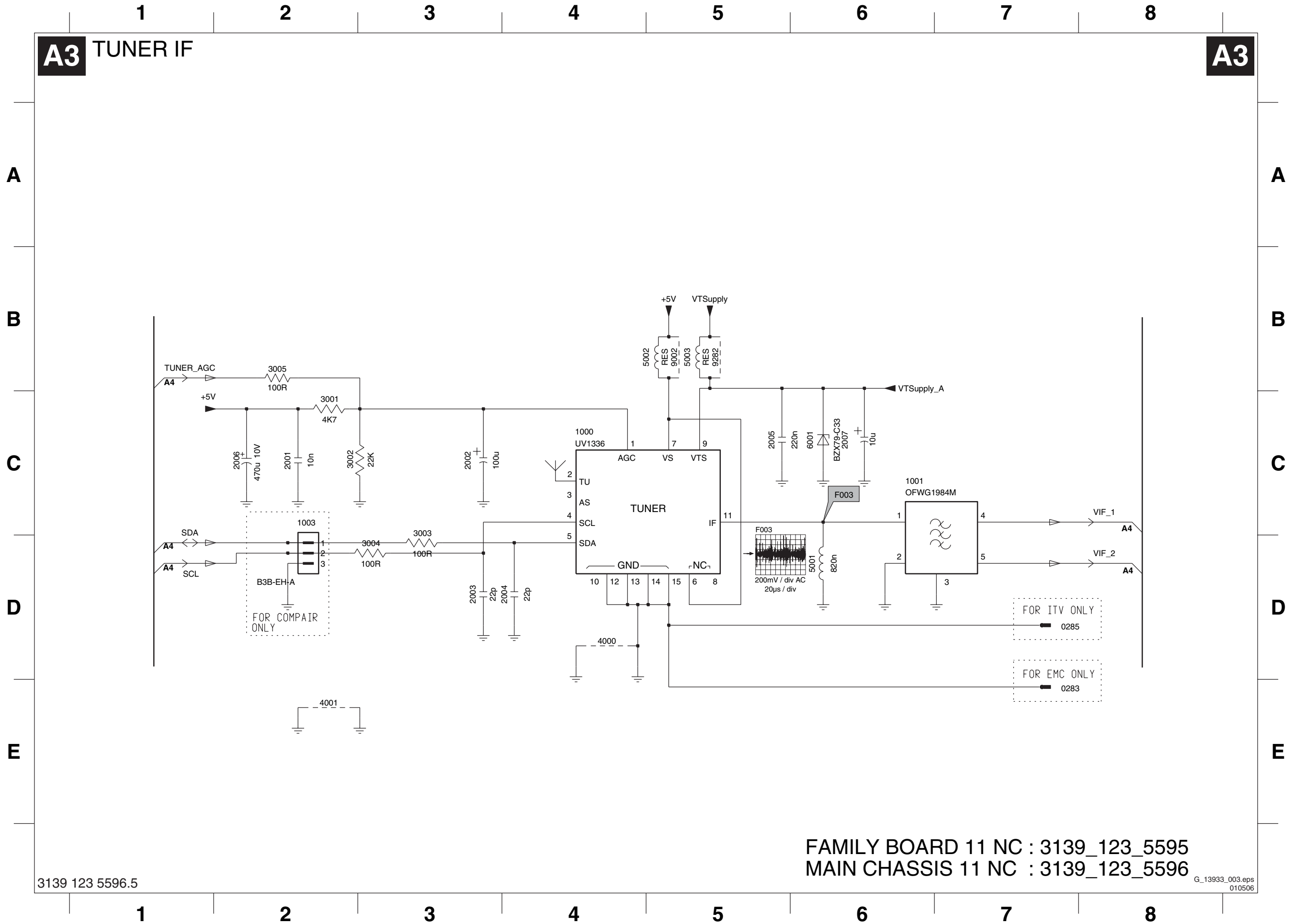

- 0283 E8
- 0285 D8
- 1000 C4
- 1001 C6
- 1003 C2
- 2001 C2
- 2002 C3
- 2003 D3
- 2004 D4
- 2005 C5
- 2006 C2
- 2007 C6
- 3001 C2
- 3002 C2
- 3003 D3
- 3004 D3
- 3005 B2
- 4000 D4
- 4001 E2
- 5001 D6
- 5002 B4
- 5003 B5
- 6001 C6
- 9002 B5
- 9282 B5

FAMILY BOARD 11 NC : 3139\_123\_5595  
 MAIN CHASSIS 11 NC : 3139\_123\_5596



Mono Carrier: Audio Processing

A5 AUDIO PROCESSING (STEREO +) SAP

A5

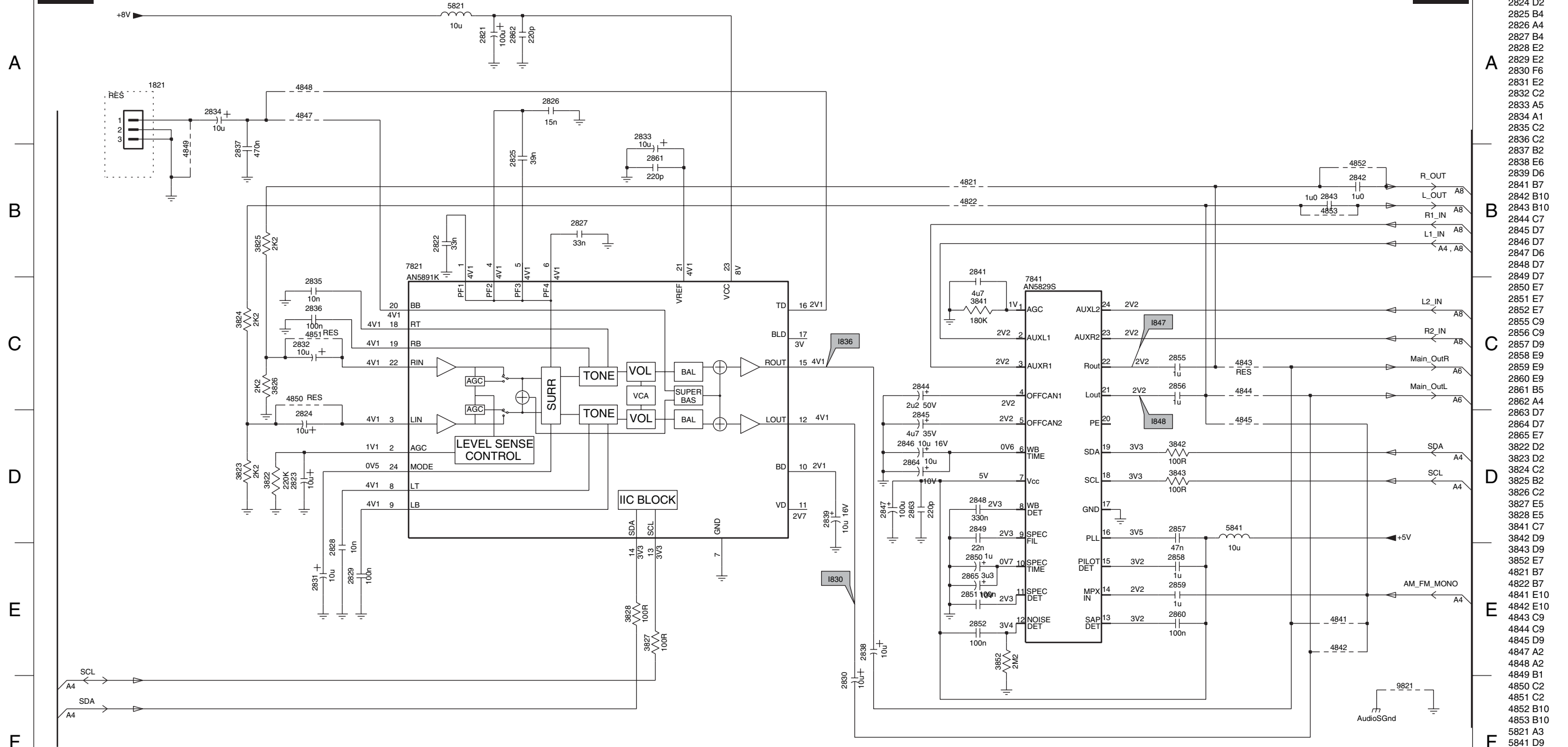

- 1821 A1
- 2821 A3
- 2822 B3
- 2823 D2
- 2824 D2
- 2825 B4
- 2826 A4
- 2827 B4
- 2828 E2
- 2829 E2
- 2830 F6
- 2831 E2
- 2832 C2
- 2833 A5
- 2834 A1
- 2835 C2
- 2836 C2
- 2837 B2
- 2838 E6
- 2839 D6
- 2841 B7
- 2842 B10
- 2843 B10
- 2844 C7
- 2845 D7
- 2846 D7
- 2847 D6
- 2848 D7
- 2849 D7
- 2850 E7
- 2851 E7
- 2852 E7
- 2855 C9
- 2856 C9
- 2857 D9
- 2858 E9
- 2859 E9
- 2860 E9
- 2861 B5
- 2862 A4
- 2863 D7
- 2864 D7
- 2865 E7
- 3822 D2
- 3823 D2
- 3824 C2
- 3825 B2
- 3826 C2
- 3827 E5
- 3828 E5
- 3841 C7
- 3842 D9
- 3843 D9
- 3852 E7
- 4821 B7
- 4822 B7
- 4841 E10
- 4842 E10
- 4843 C9
- 4844 C9
- 4845 D9
- 4847 A2
- 4848 A2
- 4849 B1
- 4850 C2
- 4851 C2
- 4852 B10
- 4853 B10
- 5821 A3
- 5841 D9
- 7821 B3
- 7841 C8
- 9821 F10

ITEM	MONO	BTSC STEREO
4841	---	JMP
4842	---	JMP
4845	JMP	---

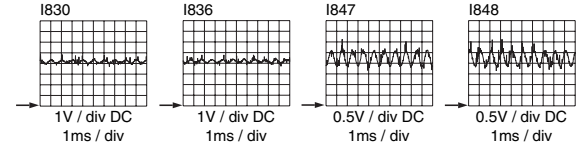

FAMILY BOARD 11NC : 3139\_123\_5595  
 MAIN CHASSIS 11NC : 3139\_123\_5596

3139 123 5596.5

Mono Carrier: Audio Amplifier

**A6** AUDIO\_AMPLIFIER + MONO\_SOUND\_PROCESSING **A6**

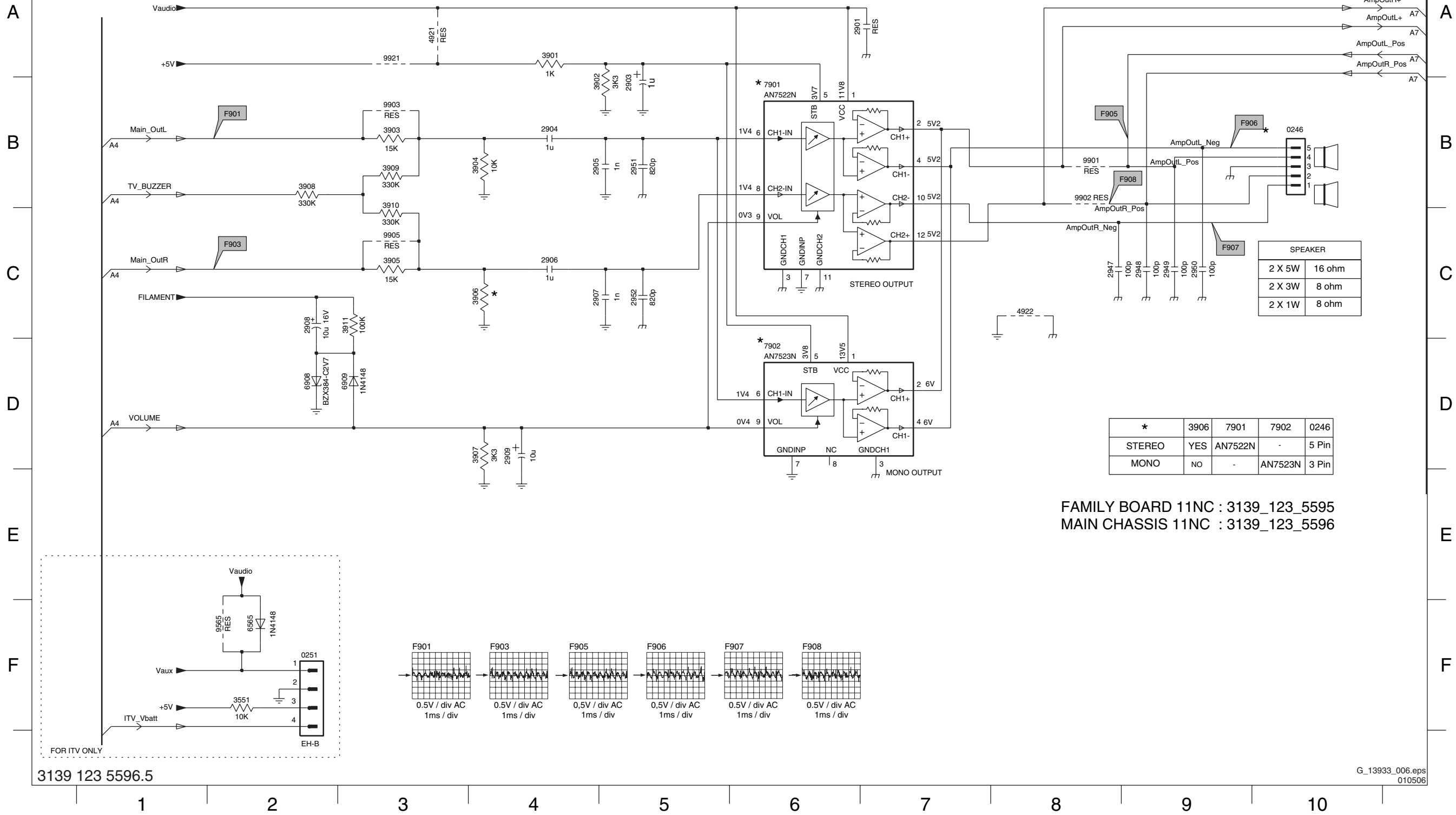

*	3906	7901	7902	0246
STEREO	YES	AN7522N	-	5 Pin
MONO	NO	-	AN7523N	3 Pin

FAMILY BOARD 11NC : 3139\_123\_5595  
 MAIN CHASSIS 11NC : 3139\_123\_5596

3139 123 5596.5

G\_13933\_006.eps  
 010506

- 0246 B10
- 0251 F2
- 2901 A6
- 2903 B5
- 2904 B4
- 2905 B4
- 2906 C4
- 2907 C4
- 2908 C2
- 2909 D4
- 2947 C8
- 2948 C9
- 2949 C9
- 2950 C9
- 2951 B5
- 2952 C5
- 3551 F2
- 3901 A4
- 3902 B5
- 3903 B3
- 3904 B4
- 3905 C3
- 3906 C4
- 3907 D4
- 3908 B2
- 3909 B3
- 3910 B3
- 3911 C3
- 4921 A3
- 4922 C8
- 6565 F2
- 6908 D2
- 6909 D3
- 7901 B6
- 7902 D6
- 9565 F2
- 9901 B8
- 9902 B8
- 9903 B3
- 9905 C3
- 9921 A3

Mono Carrier: Font I/O + Control + HP

**A7** FRONT IO + FRONT CONTROL + HEADPHONE

**A7**

- 0218-A C1
- 0218-B B1
- 0218-C B1
- 0232 E4
- 0239 B6
- 0259 E9
- 0277-A B1
- 0277-B B1
- 1181 A2
- 1182 B2
- 1183 C2
- 1184 A4
- 1185 B4
- 1600 B9
- 1601 B9
- 1602 B8
- 1603 B8
- 1604 B8
- 1606 B7
- 1681 E9
- 1981 E3
- 1982 F3
- 2181 A3
- 2182 B3
- 2183 C3
- 2185 B2
- 2186 C2
- 2691 D9
- 2693 F7
- 2694 F7
- 2695 F8
- 2696 F8
- 2981 E2
- 2982 E3
- 2983 F2
- 2984 F3
- 3181 A2
- 3182 A2
- 3183 B2
- 3184 B3
- 3185 C2
- 3186 C3
- 3681 A9
- 3682 B9
- 3683 A7
- 3684 A7
- 3685 A8
- 3686 A8
- 3687 A9
- 3688 B9
- 3689 B7
- 3691 D8
- 3692 D7
- 3693 D9
- 3694 D8
- 3695 C7
- 3981 E2
- 3982 F2
- 4692 D7
- 4694 F6
- 4695 C8
- 4698 C8
- 4699 C9
- 4981 E2
- 4982 E2
- 4983 F2
- 4984 F2
- 6181 A3
- 6691 D7
- 6692 D9
- 9181 B3
- 9683 A7
- 9694 D7
- 9982 E2

**FRONT CINCH**

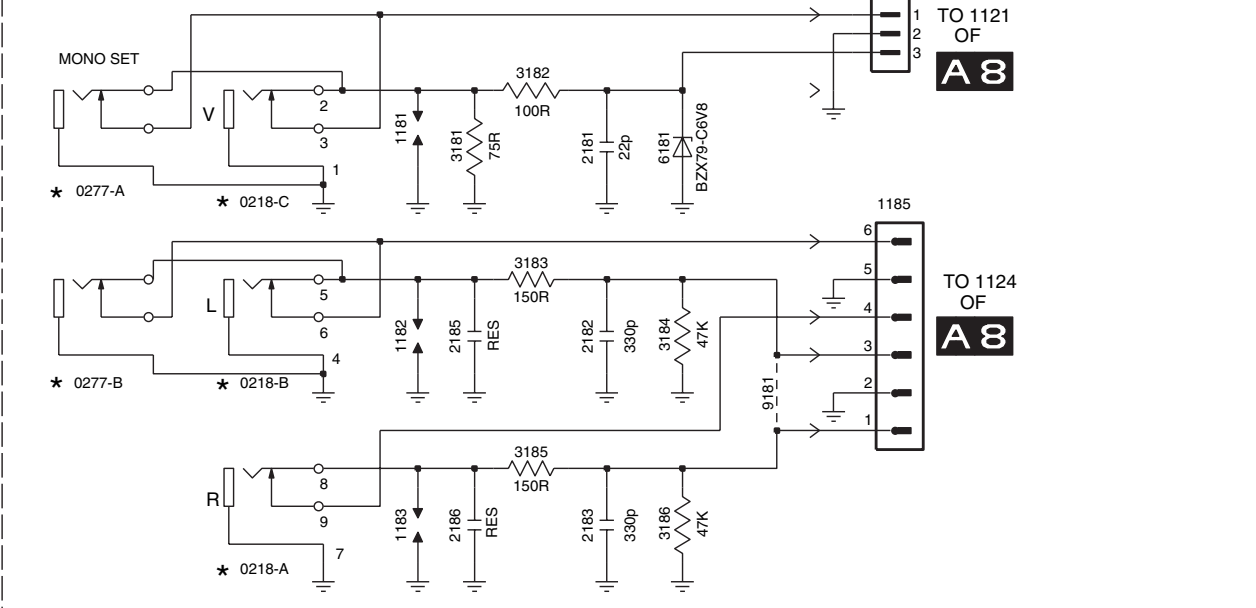

ITEM	MONO	STEREO
0218	NO	YES
0277	YES	NO

**HEADPHONE**

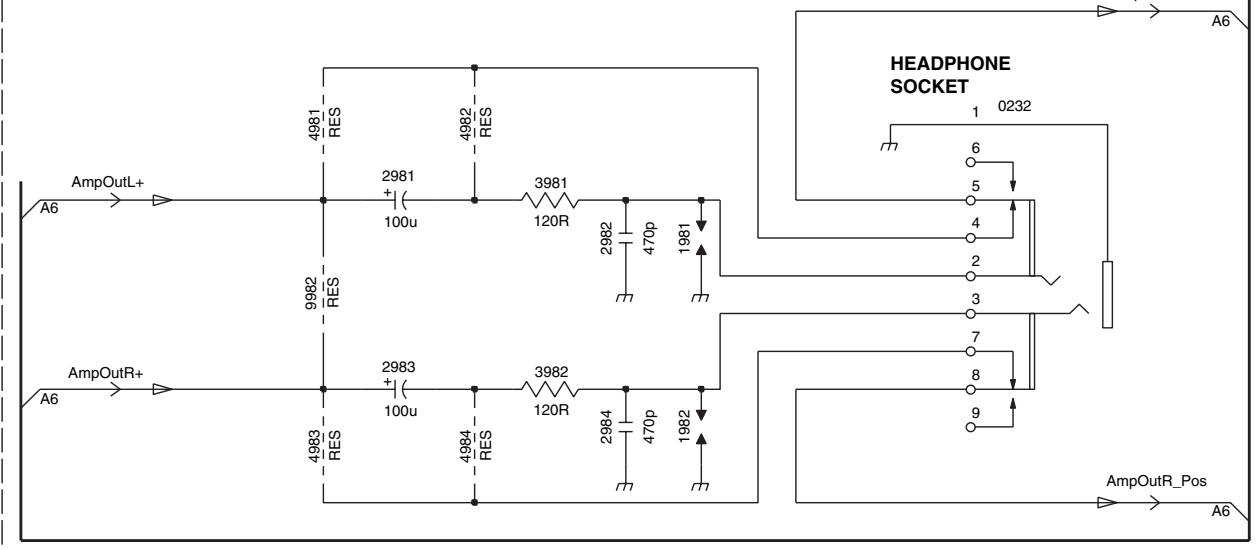

**FRONT CONTROL**

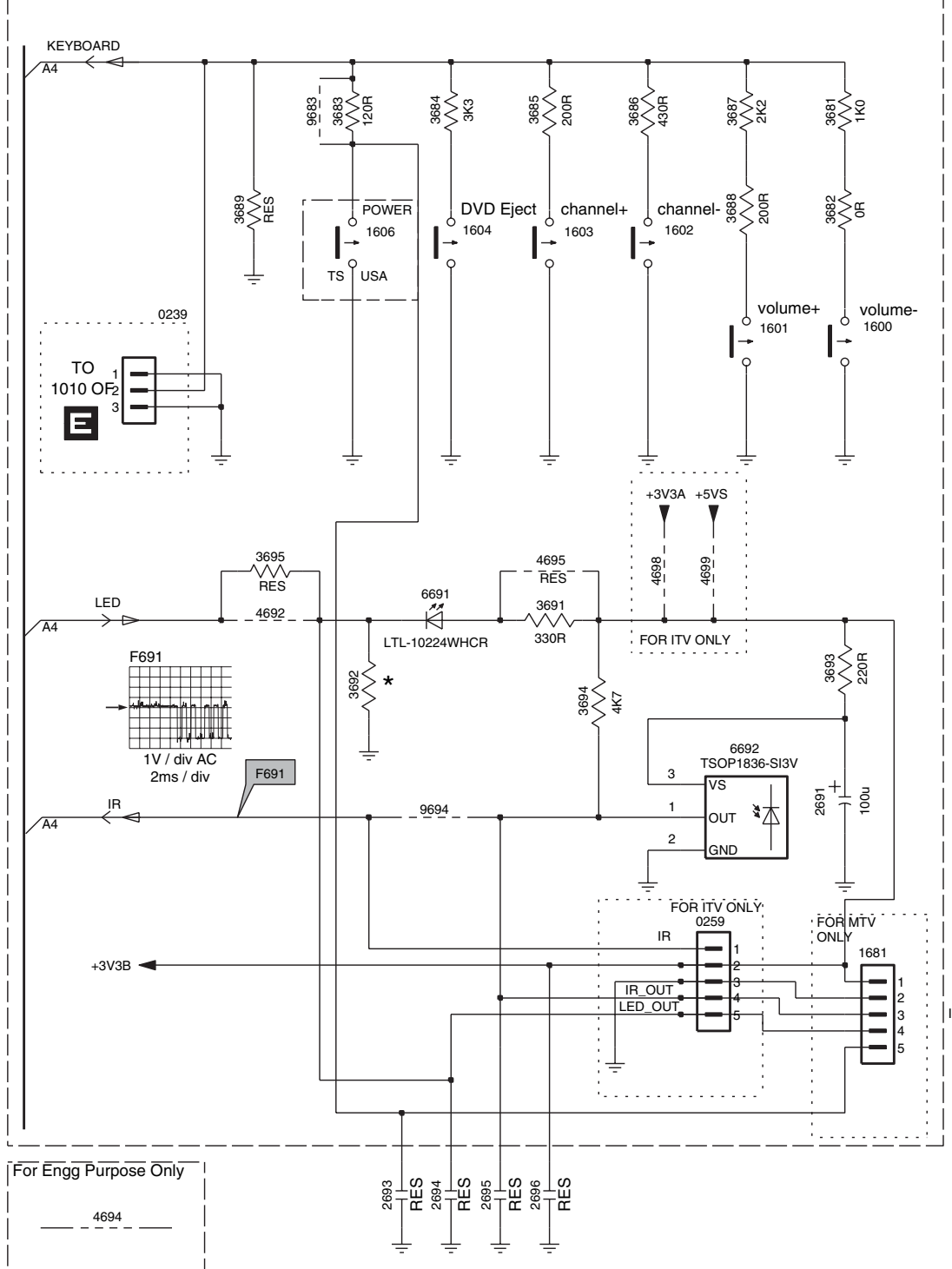

FAMILY BOARD 11 NC : 3139\_123\_5595  
 MAIN CHASSIS 11 NC : 3139\_123\_5596

3139 123 5596.5

G\_13933\_007.eps  
 010506

Mono Carrier: Rear I/O Cinch

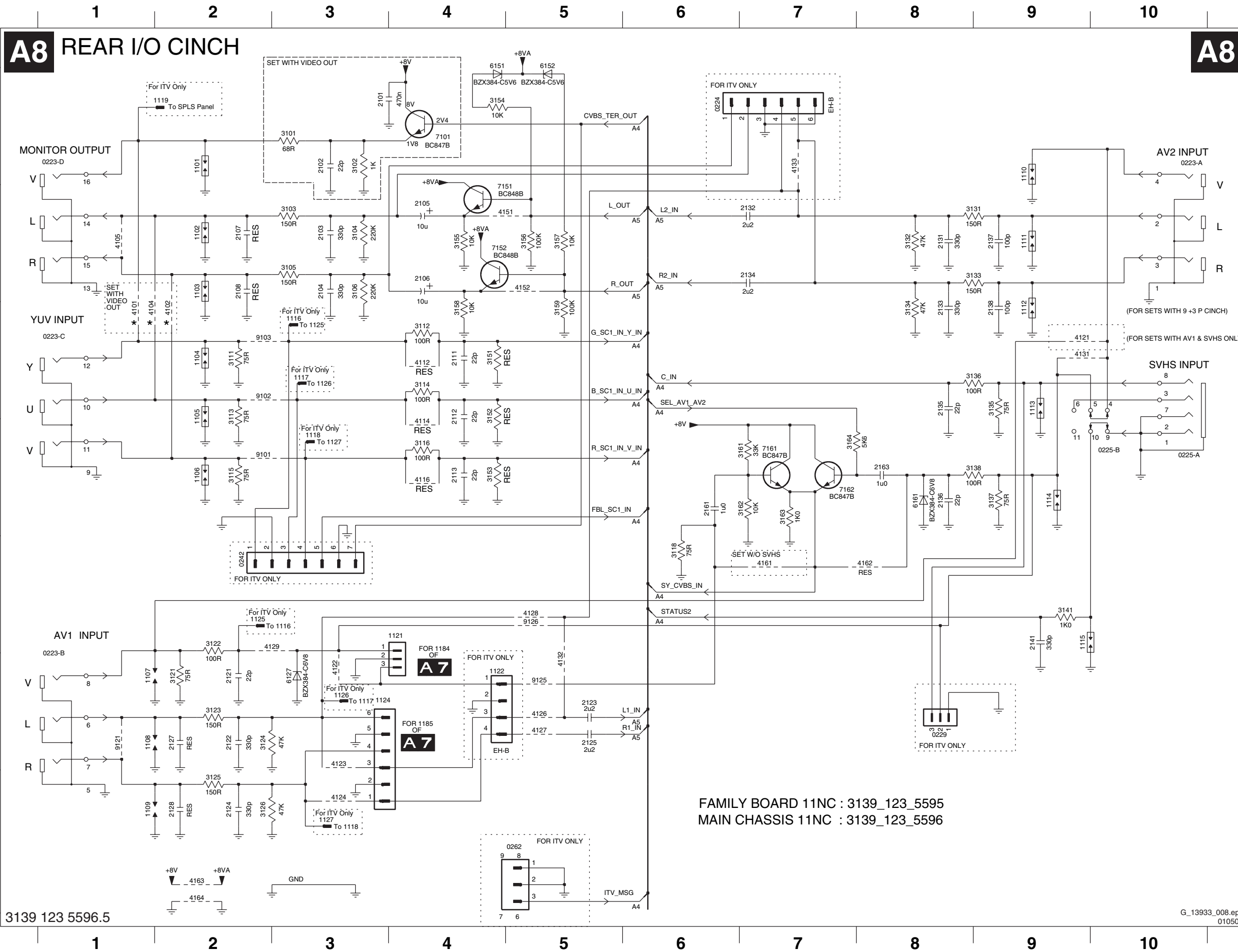

- 0223-A A10
- 0223-B F1
- 0223-C C1
- 0223-D A1
- 0224 A6
- 0225-A D10
- 0225-B D10
- 0229 F8
- 0242 E2
- 0262 G5
- 1101 A2
- 1102 B2
- 1103 B2
- 1104 C2
- 1105 C2
- 1106 D2
- 1107 F1
- 1108 F1
- 1109 G1
- 1110 A9
- 1111 B9
- 1112 C9
- 1113 C9
- 1114 D9
- 1115 E9
- 1116 C3
- 1117 C3
- 1118 D3
- 1119 A2
- 1121 E4
- 1122 F4
- 1124 F3
- 1125 E2
- 1126 F3
- 1127 G3
- 2101 A3
- 2102 A3
- 2103 B3
- 2104 B3
- 2105 B4
- 2106 B4
- 2107 B2
- 2108 B2
- 2111 C4
- 2112 C4
- 2113 D4
- 2121 F2
- 2122 F2
- 2123 F5
- 2128 G2
- 2131 B8
- 2132 B7
- 2133 C8
- 2134 B7
- 2135 C8
- 2136 D8
- 2137 B9
- 2138 C9
- 2141 E9
- 2161 D6
- 2163 D8
- 3101 A3
- 3102 A3
- 3103 B3
- 3104 B3
- 3105 B3
- 3106 B3
- 3111 C2
- 3112 C4
- 3113 C2
- 3114 C4
- 3115 D2
- 3116 D4
- 3118 E6
- 3121 F2
- 3122 E2
- 3123 F2
- 3124 F2
- 3125 G2
- 3126 G2
- 3131 B9
- 3132 B8
- 3133 B9
- 3134 C8
- 3135 C9
- 3136 C9
- 3137 D9
- 3138 D9
- 3141 E9
- 3151 C4
- 3152 C4
- 3153 D4
- 3154 A4
- 3155 B4
- 3156 B5
- 3157 B5
- 3158 C4
- 3159 C5
- 3161 D7
- 3162 D7
- 3163 D7
- 3164 D7
- 4101 C1
- 4102 C2
- 4104 C1
- 4105 B1
- 4112 C4
- 4114 D4
- 4116 D4
- 4121 C9
- 4122 F3
- 4123 F3
- 4124 G3
- 4126 F5
- 4127 F5
- 4128 E5
- 4129 E3
- 4131 C9
- 4132 F5
- 4133 A7
- 4151 B5
- 4152 B5
- 4161 E7
- 4162 E8
- 4163 G2
- 4164 G2
- 6127 F3
- 6151 A4
- 6152 A5
- 6161 D8
- 7101 A4
- 7151 B5
- 7152 B5
- 7161 D7
- 7162 D7
- 9101 D2
- 9102 C2
- 9103 C2
- 9121 F1
- 9125 F5
- 9126 E5

FAMILY BOARD 11NC : 3139\_123\_5595  
 MAIN CHASSIS 11NC : 3139\_123\_5596

3139 123 5596.5

G\_13933\_008.eps  
 010506

Mono Carrier: Diversity Table for Rear I/O

Diversity Table For **A8** Rear IO Cinch

	1	2	3	4	5		
<b>A</b>	Diversity Table For <b>A8</b> Rear IO Cinch						
	ITEM	CN-R.11/10-YUV-F.11-ST-LA/NA	CN-R.11/10-F.11-MN-LA L03S	CN-R.11/10-YUV-ST-LA/NA L03S	CN-F.11-ST-LA/NA L03S	CN-F.11-MN-LA	CN-R.11/10-MN-LA
	2101	470N	470N	470N	-	-	470N
	2102	22P	22P	22P	-	-	22P
	2103	330P	330P	330P	-	-	330P
	2104	330P	-	330P	-	-	-
	2105	10U	10U	10U	-	-	10U
	2106	10U	-	10U	-	-	-
	2111	22P	-	22P	-	-	-
	2112	22P	-	22P	-	-	-
	2113	22P	-	22P	-	-	-
	2121	-	-	22P	-	-	22P
	2122	-	-	330P	-	-	330P
	2123	-	1U	1U	1U	1U	1U
	2124	-	-	330P	-	-	-
	2125	1U	-	1U	1U	-	-
	2132	1U	-	1U	1U	-	-
	2134	1U	-	1U	1U	-	-
	2181	22P	22P	-	22P	22P	-
	2182	330P	330P	-	330P	330P	-
	2183	330P	-	330P	-	-	-
	2210	220N	220N	220N	220N	220N	220N
	2211	1N	-	1N	1N	-	1N
	2231	22N	-	22N	22N	-	22N
	2232	22N	-	22N	22N	-	22N
	2233	22N	-	22N	22N	-	22N
	2842	JMP	-	JMP	-	-	-
	2843	JMP	JMP	JMP	-	-	JMP
	3101	68R	68R	68R	-	-	68R
	3102	1K	1K	1K	-	-	1K
	3103	150R	150R	150R	-	-	150R
	3104	220K	220K	220K	-	-	220K
	3105	150R	-	150R	-	-	-
	3106	220K	-	220K	-	-	-
	3111	75R	-	75R	-	-	-
	3112	100R	-	100R	-	-	-
	3113	75R	-	75R	-	-	-
	3114	100R	-	100R	-	-	-
	3115	75R	-	75R	-	-	-
	3116	100R	-	100R	-	-	75R
	3121	-	-	100R	-	-	100R
	3122	JMP	JMP	150R	-	-	150R
	3123	JMP	JMP	47K	-	-	47K
	3124	-	-	150R	-	-	-
	3125	JMP	-	47K	-	-	-
	3126	-	-	-	-	-	-
	3181	75R	75R	-	75R	75R	-
	3182	100R	100R	-	100R	100R	-
	3183	150R	150R	-	150R	150R	-
	3184	47K	47K	-	47K	47K	-
	3185	150R	-	-	150R	-	-
	3186	47K	-	100R	47K	-	-
	3210	100R	100R	100R	100R	100R	100R
	3231	560R	-	560K	560R	-	560R
	3232	1K	-	1K	1K	-	1K
	4101	-	JMP	-	-	-	JMP
	4102	-	-	-	-	-	-
	4104	-	JMP	-	-	-	JMP
	4122	-	-	JMP	-	-	JMP
	4123	-	-	JMP	-	-	JMP
	4124	-	-	JMP	JMP	-	JMP
	4126	JMP	JMP	JMP	JMP	-	JMP
	4127	JMP	-	JMP	JMP	-	JMP
	4129	JMP	JMP	JMP	-	-	JMP
	4132	JMP	-	JMP	JMP	-	-
	4133	JMP	-	JMP	JMP	-	-
	4151	JMP	JMP	JMP	-	-	JMP
	4152	JMP	-	JMP	-	-	-
	4161	JMP	JMP	JMP	JMP	-	JMP
	6127	-	-	BZX79-C6V8	-	-	BZX384-C6V8
	6181	BZX79-C6V8	BZX79-C6V8	-	BZX79-C6V8	BZX79-C6V8	-
	7101	BC847B	BC847B	BC847B	-	-	BC847B
	9101	JMP	-	JMP	-	-	-
	9102	JMP	-	JMP	-	-	-
	9103	JMP	-	JMP	-	-	-
	9125	JMP	JMP	JMP	JMP	-	JMP

3139 123 5596.1

CL 36532044\_009.eps  
200603

Mono Carrier: DVD Power Supply (Optional)

# A9 DVD POWER SUPPLY

# A9

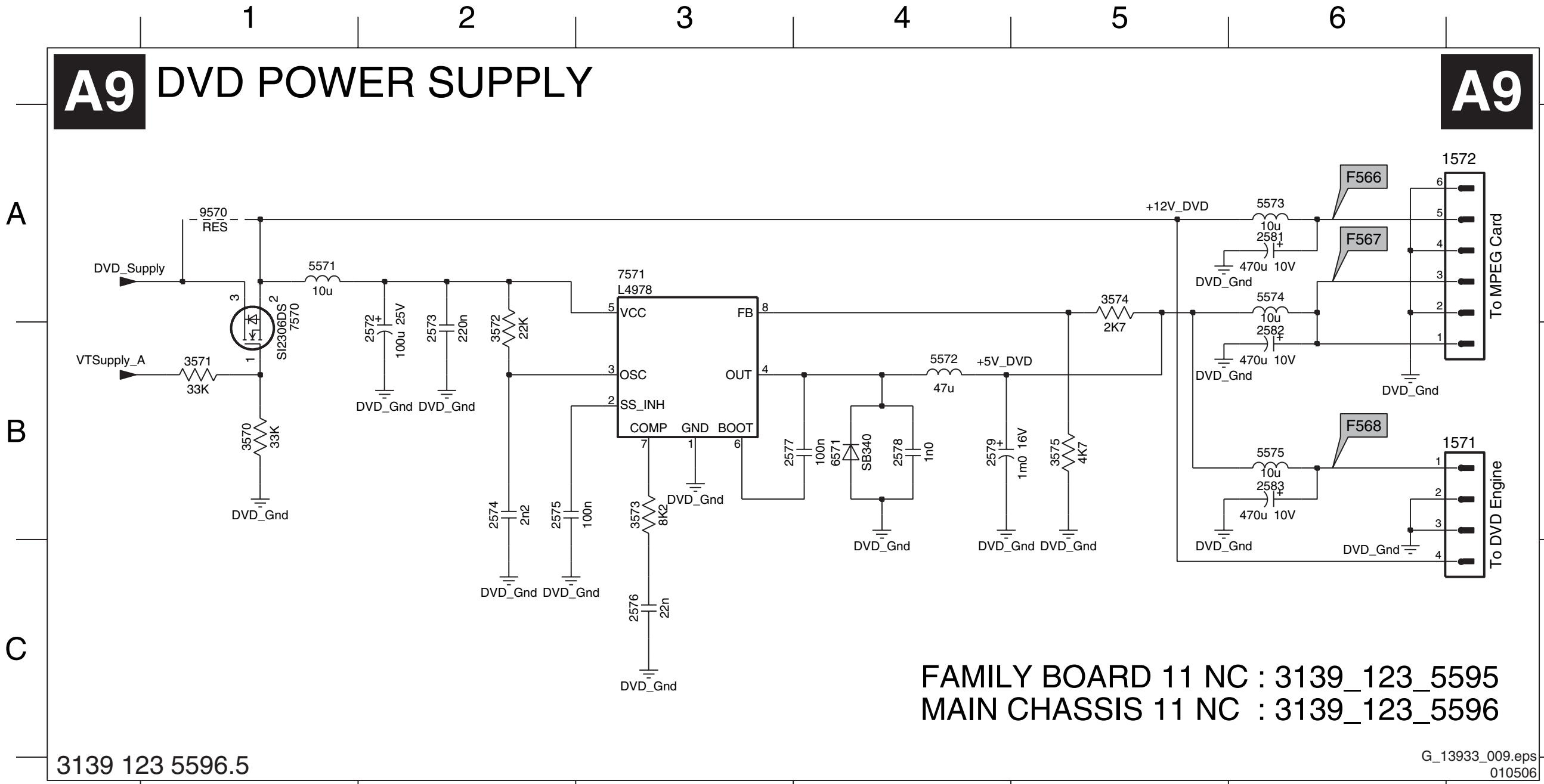

- 1571 B6
- 1572 A6
- 2572 B2
- 2573 B2
- 2574 B2
- 2575 B2
- 2576 C3
- 2577 B3
- 2578 B4
- 2579 B4
- 2581 A6
- 2582 B6
- 2583 B6
- 3570 B1
- 3571 B1
- 3572 B2
- 3573 B3
- 3574 A5
- 3575 B5
- 5571 A1
- 5572 B4
- 5573 A6
- 5574 A6
- 5575 B6
- 6571 B4
- 7570 A1
- 7571 A3
- 9570 A1

FAMILY BOARD 11 NC : 3139\_123\_5595  
 MAIN CHASSIS 11 NC : 3139\_123\_5596

3139 123 5596.5

G\_13933\_009.eps  
010506

Layout Mono Carrier: (Top Side)

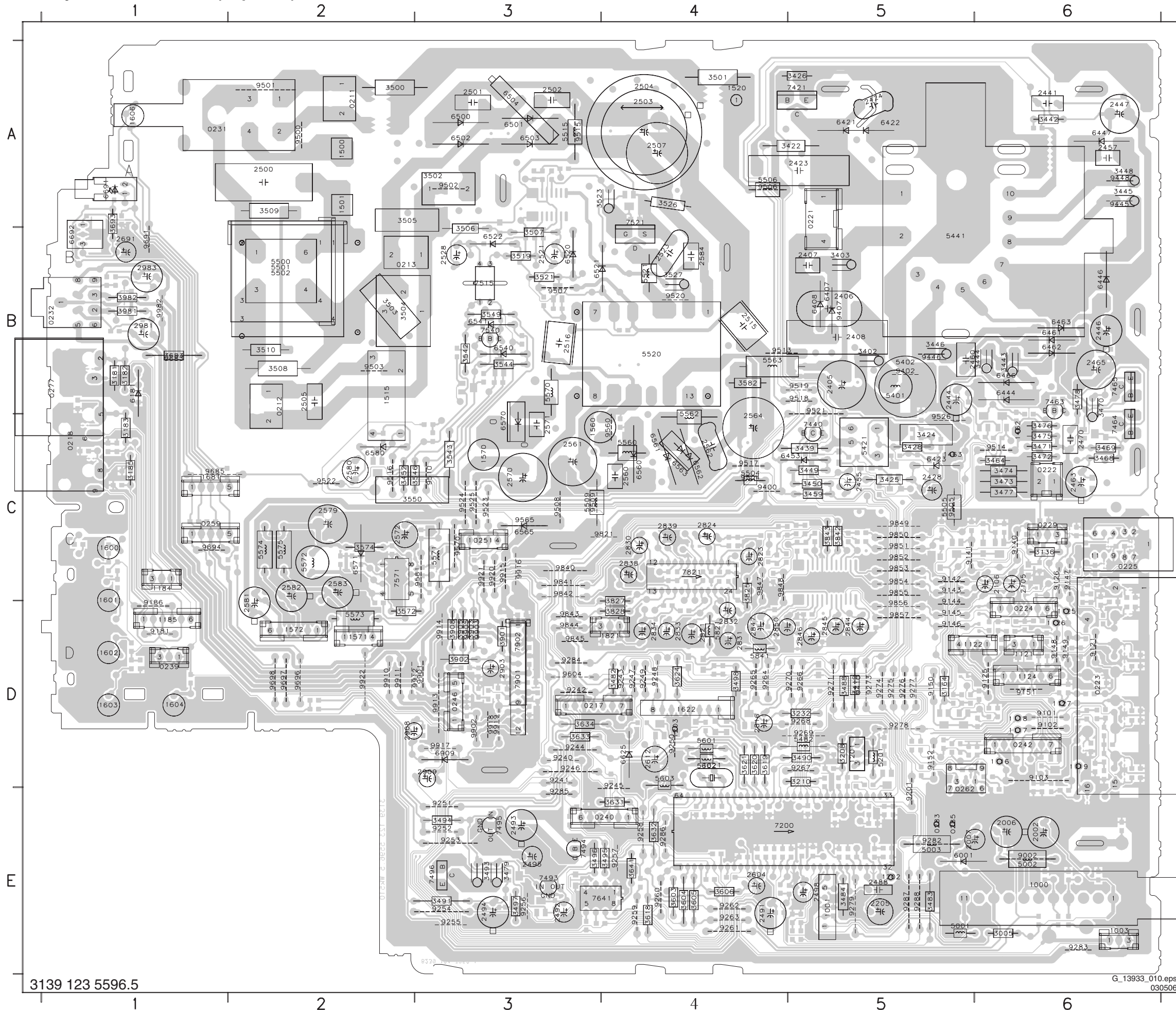

0211 A2	2505 B2	3505 A2	6522 B3	9402 B5
0212 B2	2507 A4	3506 B3	6540 B3	9407 B5
0213 B2	2515 B4	3507 B3	6541 B3	9410 D5
0217 D3	2516 B3	3508 B2	6560 C4	9445 A6
0218 C1	2521 B3	3509 A2	6561 C4	9446 B5
0221 A5	2523 B4	3510 B2	6562 C4	9448 A6
0222 C6	2528 B3	3519 B3	6563 C4	9500 A2
0223 D6	2560 C4	3521 B3	6565 C3	9501 A2
0224 D6	2561 C3	3523 A3	6570 C3	9502 A3
0225 C6	2562 C4	3526 A4	6571 C2	9503 B2
0229 C6	2564 C4	3527 B4	6580 C2	9504 C4
0231 A1	2570 C3	3542 B3	6625 D4	9505 C5
0232 B1	2571 C3	3543 C3	6691 A1	9506 A4
0239 D1	2572 C2	3544 B3	6692 B1	9507 B3
0240 E4	2579 C2	3546 C3	6909 D3	9508 C3
0242 D6	2580 C2	3549 B3	7200 E4	9509 C3
0246 D3	2581 D2	3550 C2	7421 A5	9510 C3
0251 C3	2582 C2	3572 D2	7440 C5	9513 B4
0259 C1	2583 C2	3574 C2	7463 B6	9514 C6
0262 E5	2584 B4	3582 B4	7464 C6	9515 A3
0277 B1	2604 E4	3603 E4	7465 B6	9516 C2
0283 E5	2612 D4	3604 E4	7493 E3	9517 C4
0285 E5	2616 D4	3605 E4	7494 E3	9518 B5
1000 E6	2691 B1	3606 E4	7495 E3	9519 B5
1001 E5	2821 D4	3618 E4	7496 E3	9520 B4
1003 E6	2823 C4	3619 D4	7515 B3	9521 B5
1116 D6	2824 C4	3620 D4	7521 A4	9522 C2
1117 D6	2830 C4	3621 D4	7540 B3	9523 C3
1118 D6	2831 D4	3624 D4	7571 C2	9524 C3
1119 D6	2832 D4	3631 E4	7641 E4	9525 C3
1121 D6	2833 D4	3632 E4	7821 C4	9526 C5
1122 D5	2834 D4	3633 D3	7901 D3	9560 C4
1124 D6	2838 C4	3634 D3	7902 D3	9565 C3
1125 D6	2839 C4	3641 E4	9002 E6	9570 C3
1126 D6	2844 D5	3683 B1	9101 D6	9581 C3
1127 D6	2845 D5	3693 A1	9102 D6	9604 D3
1184 C1	2846 D5	3825 C4	9103 D6	9683 B1
1185 D1	2847 D4	3827 D4	9121 D6	9685 C1
1201 D5	2850 D4	3828 D4	9125 D6	9691 B1
1202 E5	2903 D3	3842 C5	9126 C6	9694 C1
1203 D4	2908 D2	3843 C5	9140 C6	9696 D2
1462 C6	2909 D3	3901 C3	9141 C5	9697 D2
1463 C5	2981 B1	3902 D3	9142 C5	9698 D2
1500 A2	2983 B1	3903 D3	9143 C5	9821 C4
1501 A2	3005 E6	3905 D3	9144 D5	9840 C3
1508 B3	3136 C6	3908 D3	9145 D5	9841 C3
1509 B3	3164 D5	3981 B1	9146 D5	9842 C3
1515 B2	3181 B1	3982 B1	9147 C6	9843 D3
1516 B4	3182 B1	5001 E5	9148 D6	9844 D3
1520 A4	3183 C1	5002 E6	9149 D6	9845 C3
1521 B2	3185 C1	5003 E5	9150 D5	9847 C4
1522 B2	3208 D5	5201 D5	9151 D6	9848 C4
1523 B2	3210 D5	5401 B5	9152 D5	9849 C5
1524 B2	3232 D5	5402 B5	9181 D1	9850 C5
1560 C3	3402 B5	5421 C5	9186 D1	9851 C5
1570 C3	3403 B5	5441 B5	9201 E5	9852 C5
1571 D2	3410 D5	5482 D5	9240 D3	9853 C5
1572 D2	3422 A5	5500 B2	9241 D3	9854 C5
1600 C1	3424 C5	5501 B2	9242 D3	9855 C5
1601 C1	3425 C5	5502 B2	9243 D4	9856 D5
1602 D1	3426 A5	5504 C4	9244 D3	9857 D5
1603 D1	3428 C5	5505 C5	9245 D4	9901 D3
1604 D1	3439 C5	5506 A4	9246 D3	9902 D3
1606 A1	3442 A6	5509 C3	9247 D4	9903 D3
1621 D4	3443 B6	5515 A3	9248 D4	9905 D3
1622 D4	3444 B6	5520 B4	9249 D4	9910 D2
1681 C1	3445 A6	5521 B4	9250 D4	9911 D2
1821 D4	3446 B5	5560 C4	9251 E3	9912 D3
2002 E6	3448 A6	5562 B4	9252 E3	9913 D3
2006 E6	3449 C5	5563 B4	9253 E3	9914 D3
2007 E5	3450 C5	5570 B3	9254 E3	9915 C3
2105 C6	3452 C2	5571 C3	9255 E3	9916 C3
2106 C6	3459 C5	5572 C2	9256 E3	9917 D3
2205 E5	3464 C6	5573 D2	9257 E4	9918 D3
2405 B5	3468 C6	5574 C2	9258 E4	9919 D3
2406 B5	3469 C6	5575 C2	9259 E4	9920 C3
2407 B5	3470 B6	5601 D4	9260 E4	9921 C3
2408 B5	3471 C6	5602 D4	9261 E4	9922 D2
2423 A5	3472 C6	5603 D4	9262 E4	
2424 A5	3473 C6	5621 D4	9263 E4	
2428 C5	3474 C6	5841 D4	9264 D4	
2441 A6	3475 C6	6001 E5	9265 D4	
2444 B5	3476 C6	6181 B1	9266 D5	
2446 B6	3477 C6	6407 B5	9267 D5	
2447 A6	3478 B6	6408 B5	9268 D5	
2455 C5	3479 E3	6421 A5	9269 D5	
2457 A6	3482 D4	6422 A5	9270 D5	
2460 B5	3483 E5	6423 C5	9271 D5	
2463 C6	3484 E5	6444 B6	9273 D5	
2465 B6	3488 D5	6446 B6	9274 D5	
2470 C6	3490 D5	6447 A6	9275 D5	
2488 E5	3491 E3	6453 C5	9276 D5	
2491 E4	3493 E3	6461 B6	9277 D5	
2492 E3	3494 E3	6462 B6	9278 D5	
2493 E3	3495 E4	6463 B6	9279 E5	
2494 E3	3496 E3	6466 B6	9282 E5	
2495 E3	3497 E3	6500 A3	9283 E6	
2498 E5	3498 D4	6501 A3	9284 D3	
2500 A2	3500 A2	6502 A3	9285 E3	
2501 A3	3501 A4	6503 A3	9286 E4	
2502 A3	3502 A3	6504 A3	9287 E5	
2503 A4	3503 B2	6520 B3	9288 E5	
2504 A4	3504 B2	6521 B3	9400 C4	

Layout Mono Carrier (Overview Bottom Side)

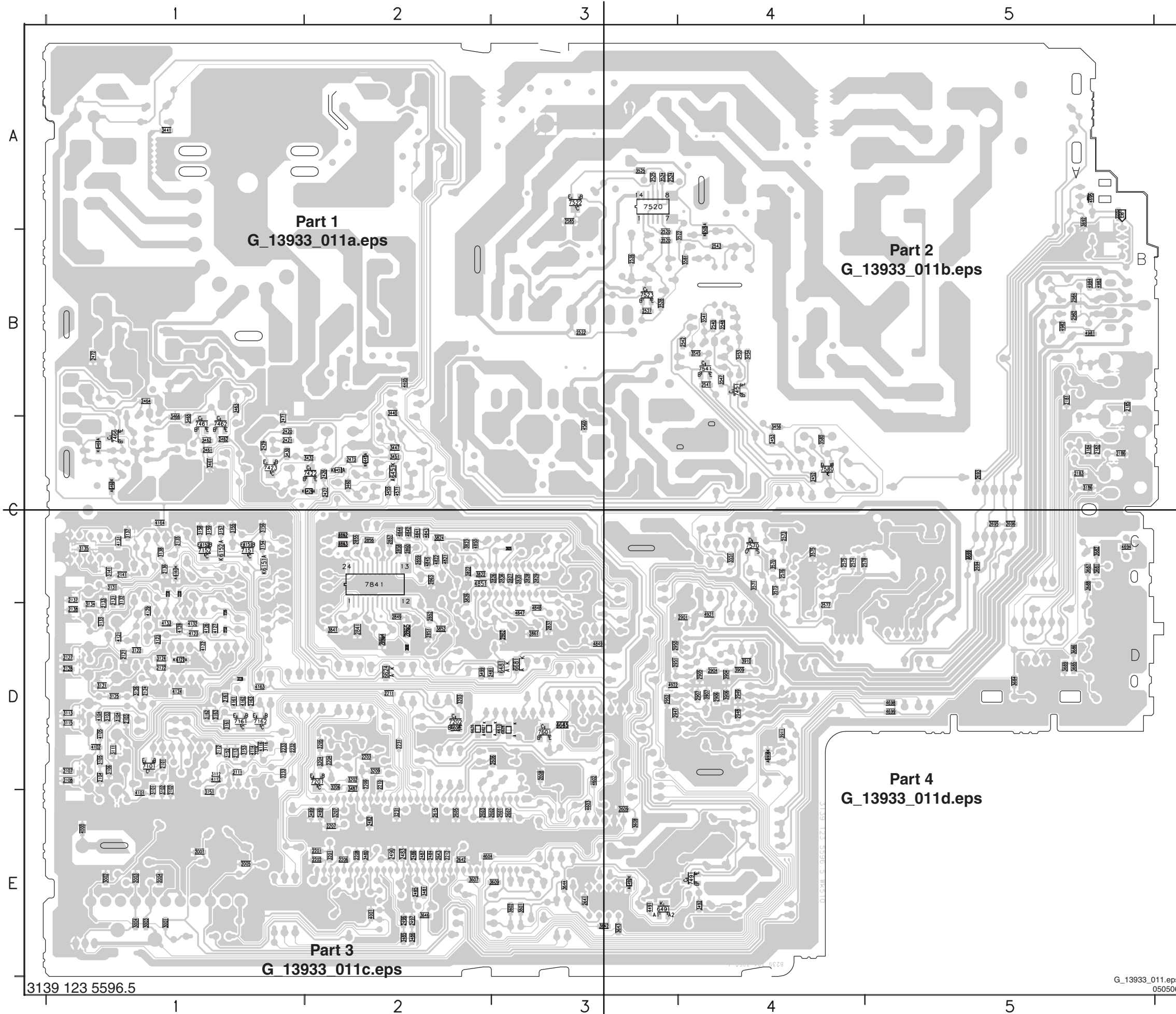

2001	E1	2856	C2	3643	E3	7522	A3
2003	E1	2857	C2	3644	E3	7523	B3
2004	E1	2858	C2	3645	D3	7541	B4
2005	E1	2859	C2	3646	E3	7570	C4
2101	D1	2860	C2	3681	C5	7580	C4
2102	E1	2861	D3	3682	C5	7601	D3
2103	D1	2862	D3	3684	D5	7841	C2
2104	D1	2863	C2	3685	D5		
2107	D1	2864	D2	3686	D5		
2108	D1	2865	D2	3687	C5		
2111	D1	2901	D4	3688	C5		
2112	D1	2904	D4	3689	D5		
2113	D1	2905	D4	3691	A5		
2121	D1	2906	D4	3692	A5		
2122	D1	2907	D4	3694	A5		
2123	D1	2947	D3	3695	C5		
2124	D1	2948	D4	3822	C2		
2125	D1	2949	D4	3823	C2		
2127	D1	2950	D3	3824	C2		
2128	D1	2951	D3	3826	C2		
2131	C1	2952	D3	3841	D2		
2132	C1	2982	B5	3852	D2		
2133	D1	2984	B5	3904	D4		
2134	C1	3001	E1	3906	D4		
2135	C1	3002	E1	3907	D4		
2136	C1	3003	E1	3909	D4		
2137	C1	3004	E1	3910	D4		
2138	D1	3101	E1	3911	D4		
2141	C1	3102	E1	4000	E1		
2161	D1	3103	D1	4001	E2		
2163	D1	3104	D1	4101	E1		
2181	B5	3105	D1	4102	D1		
2182	C1	3106	D1	4104	D1		
2183	C5	3111	D1	4105	D1		
2185	B5	3112	D1	4112	D1		
2186	C5	3113	D1	4114	D1		
2201	E2	3114	D1	4116	D1		
2202	E2	3115	D1	4121	D1		
2203	D2	3116	D1	4122	D1		
2204	D2	3118	D1	4123	D1		
2206	E2	3121	D1	4124	D1		
2207	E2	3122	D1	4126	D1		
2208	E2	3123	D1	4127	D1		
2209	D2	3124	D1	4128	D1		
2210	D2	3125	D1	4129	D1		
2211	D2	3126	D1	4131	C1		
2212	E2	3131	C1	4132	D1		
2231	D2	3132	C1	4133	D1		
2232	D1	3133	D1	4151	C1		
2233	D1	3134	D1	4152	C1		
2420	C1	3135	C1	4161	D1		
2421	C1	3137	C1	4162	D1		
2426	C2	3138	C1	4163	D1		
2427	C2	3141	C1	4164	C1		
2429	C1	3151	E1	4405	B2		
2452	C4	3152	D1	4491	E3		
2453	C4	3153	D1	4560	C3		
2461	C1	3154	C1	4571	C2		
2462	C1	3155	C1	4602	D3		
2464	B1	3156	C1	4603	E3		
2471	C1	3157	C1	4604	D2		
2472	B1	3158	C1	4606	D2		
2473	C2	3159	C1	4610	D3		
2481	D2	3161	D1	4661	D3		
2482	E2	3162	D1	4692	C5		
2483	E2	3163	D1	4694	C5		
2484	E2	3184	C5	4695	A5		
2485	E2	3186	C5	4698	D5		
2486	E2	3201	E2	4699	D5		
2487	E2	3202	D2	4821	C2		
2489	E2	3203	D2	4822	C2		
2490	E2	3204	D2	4841	C2		
2496	E2	3205	D2	4842	C2		
2497	E2	3206	D2	4843	C2		
2520	B3	3207	E2	4844	C2		
2522	B3	3209	D2	4845	C2		
2524	A3	3231	E2	4847	D3		
2525	A3	3233	D1	4848	D3		
2526	B3	3430	C1	4849	D3		
2527	B3	3432	C2	4850	C2		
2540	B4	3440	B2	4851	C2		
2541	B4	3441	A1	4852	C2		
2542	B4	3447	C2	4853	C2		
2543	B4	3451	C2	4921	D4		
2573	C4	3453	B4	4922	D3		
2574	C4	3454	B4	4981	B5		
2575	C4	3455	C2	4982	B5		
2576	C4	3456	C4	4983	B5		
2577	D4	3460	C2	4984	B5		
2578	C4	3461	C1	6127	D1		
2585	A3	3462	C1	6151	C1		
2601	E3	3463	B1	6152	C1		
2602	E2	3465	C1	6161	C1		
2603	E2	3466	C1	6426	C2		
2605	E2	3480	E2	6445	C2		
2606	D3	3481	E2	6451	C2		
2607	E3	3485	E2	6452	C2		
2608	D3	3486	E2	6460	C1		
2609	E3	3487	D2	6464	C1		
2615	E3	3489	E2	6481	D3		
2641	E3	3492	E4	6491	E3		
2642	E2	3499	D2	6492	E3		
2643	E2	3520	B3	6505	B4		
2693	C5	3522	B4	6624	D2		
2694	C5	3524	A3	6626	D2		
2695	C5	3525	A3	6627	D2		
2696	C5	3528	B3	6628	D3		
2822	C2	3541	B4	6681	D3		
2825	C3	3545	B4	6908	D4		
2826	C3	3547	B4	7101	D1		
2827	C3	3548	B4	7151	C1		
2828	C3	3551	C4	7152	C1		
2829	C3	3570	C4	7161	D1		
2835	C3	3571	C4	7162	D1		
2836	C3	3573	C4	7201	D2		
2837	D3	3575	C4	7202	D2		
2841	D2	3580	C4	7422	C2		
2842	C2	3581	B4	7423	C1		
2843	C2	3601	E3	7451	B4		
2848	D2	3602	E3	7461	C1		
2849	D2	3607	E2	7462	C1		
2851	D2	3608	E3	7466	C1		
2852	D2	3609	E3	7491	E4		
2855	C2	3642	E3	7520	A3		

Layout Mono Carrier (Part 1 Bottom Side)

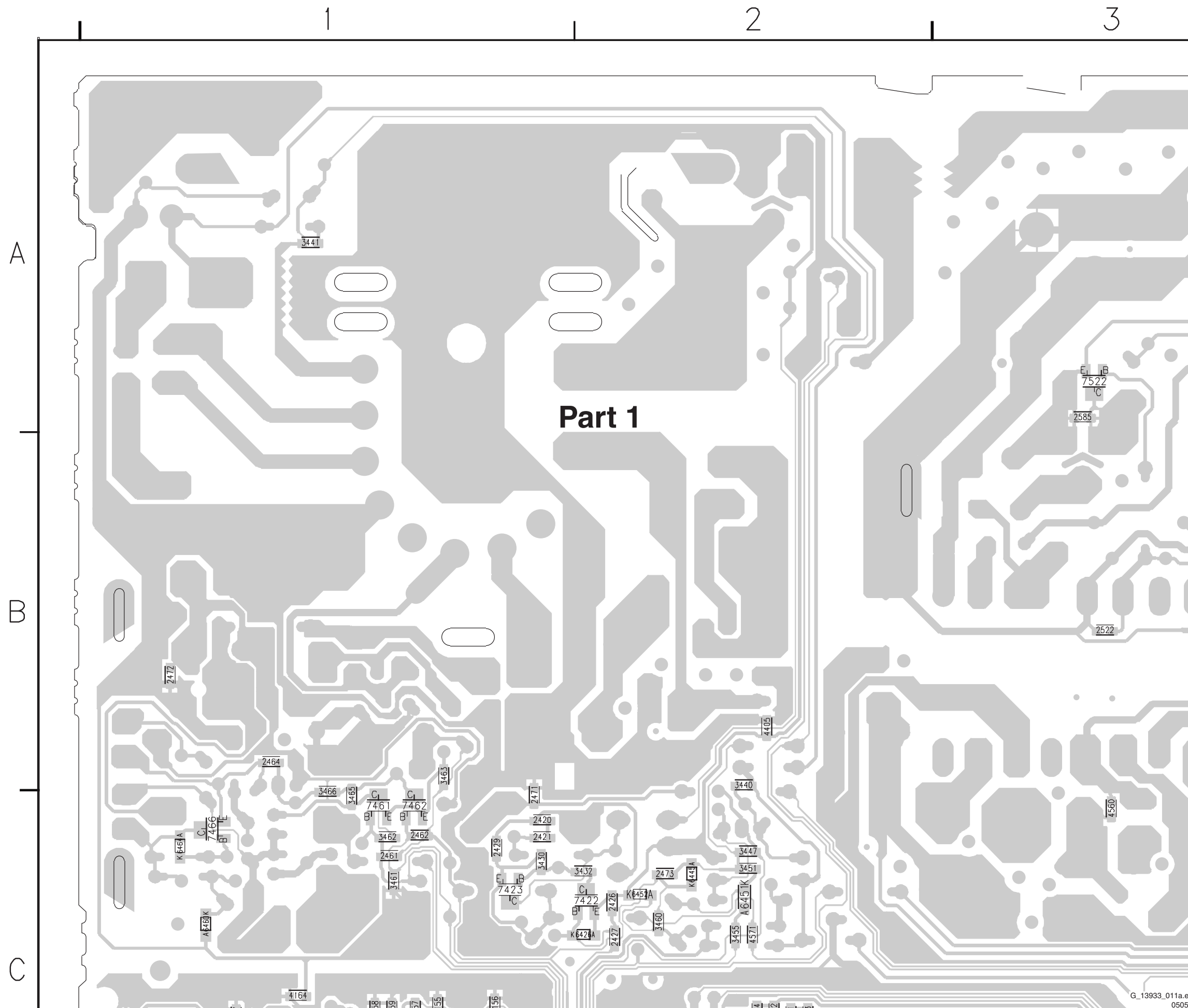

Layout Mono Carrier (Part 2 Bottom Side)

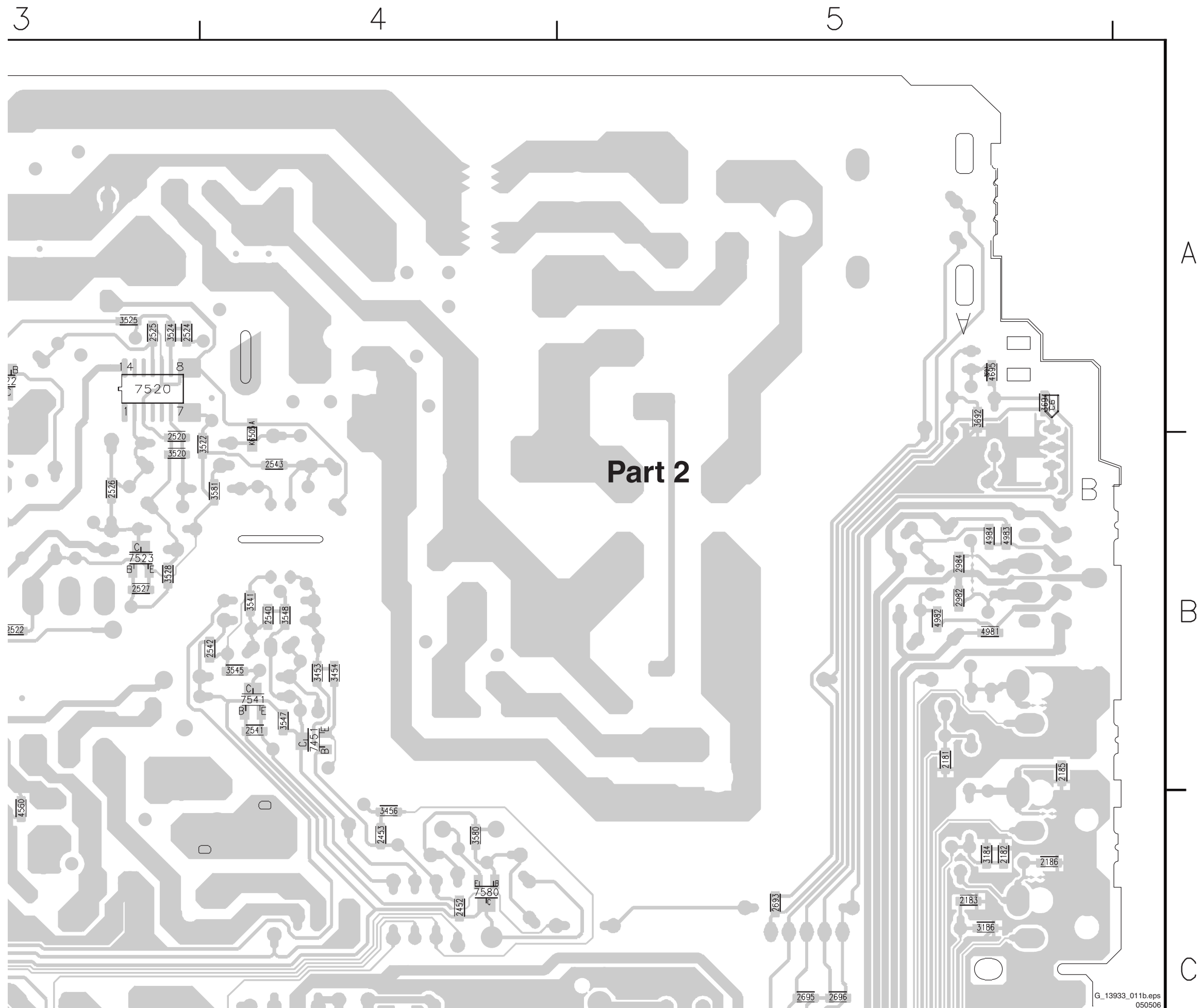







Layout CRT Panel (Top Side)

VG2 A2	1302 A1	3300 A2	3308 A2	3318 A1	7312 A2	7316 A2	9302 A2	9315 A2
0165 A1	1303 A1	3301 A2	3309 A1	3319 A1	7313 A2	7317 A2	9303 A2	9316 A2
1300 A2	2303 A2	3304 A2	3310 A2	7308 A2	7314 A2	7318 A2	9304 A2	9317 A2
1301 A1	2304 A2	3305 A1	3313 A2	7310 A2	7315 A2	9300 A2	9314 A2	9318 A2

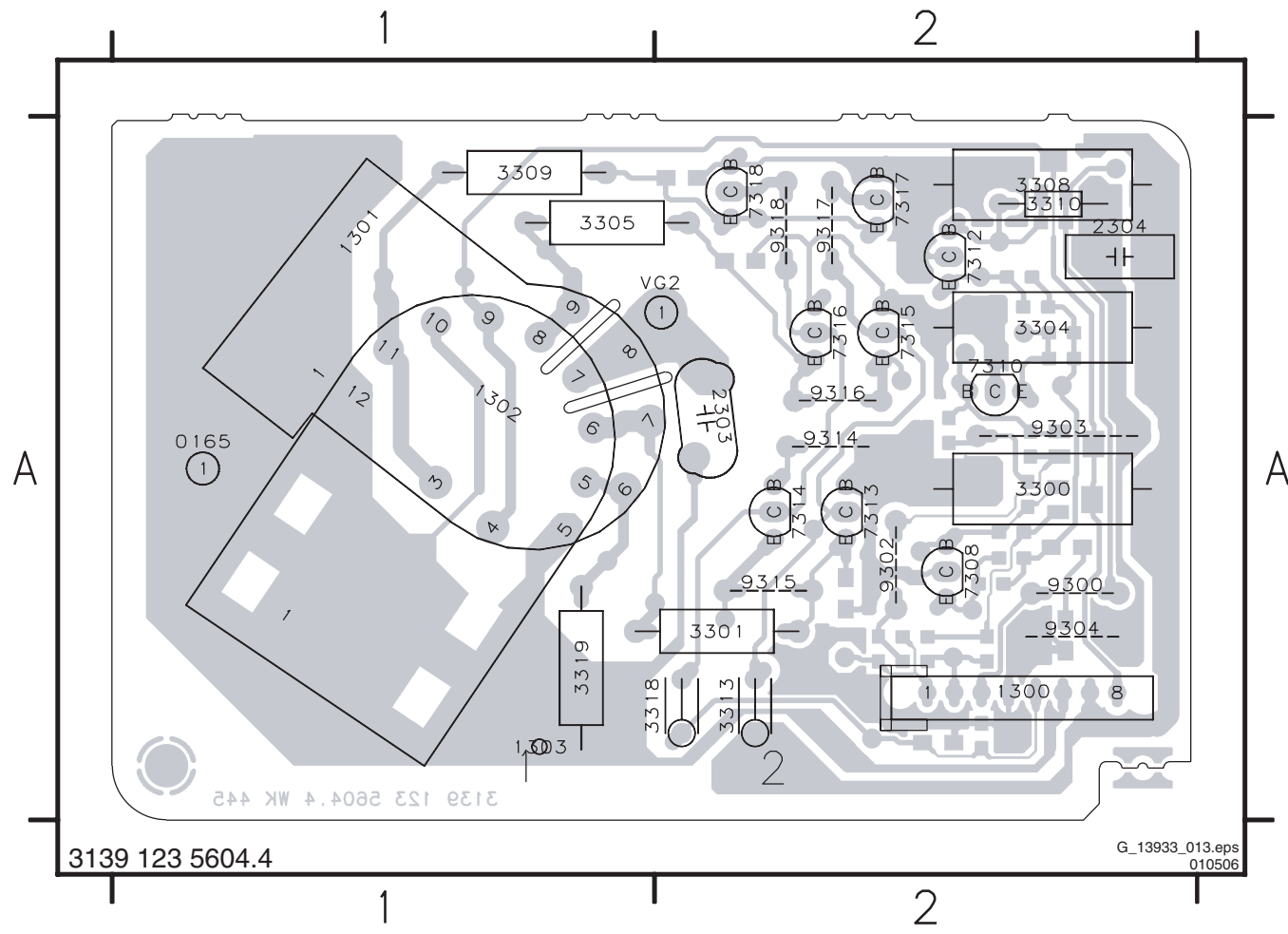

Layout CRT Panel (Bottom Side)

2300 A1	3302 A1	3311 A1	4303 A1	4307 A1	6316 A1	7309 A1
2301 A1	3303 A1	4300 A1	4304 A1	6301 A1	6317 A1	7311 A1
2302 A1	3306 A1	4301 A1	4305 A1	6307 A1	6318 A1	
2318 A1	3307 A1	4302 A1	4306 A1	6313 A1	7307 A1	

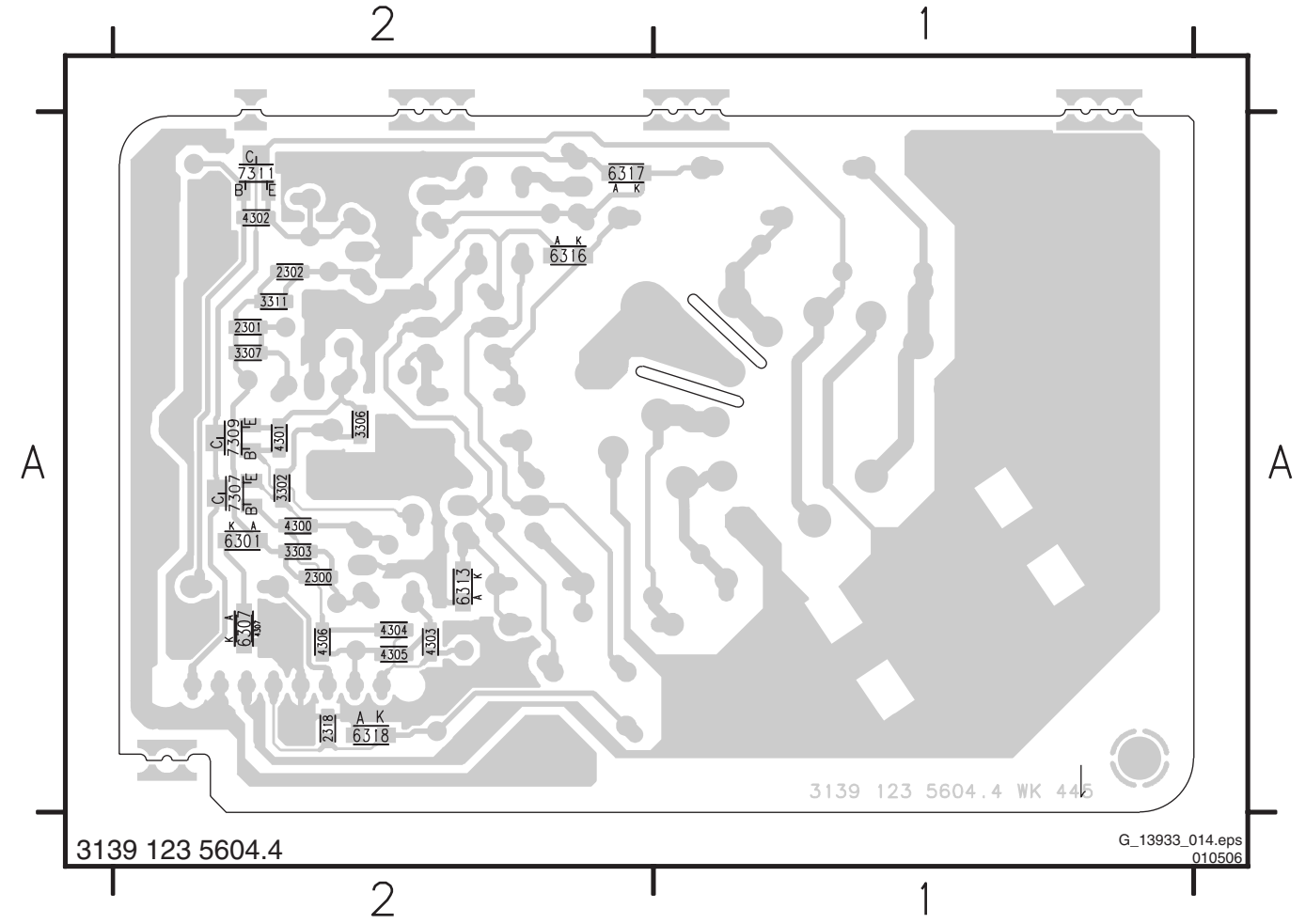

Side AV Panel

**D** SIDE AV

**D**

- 0250-A D5
- 0250-B C5
- 0250-C B5
- 0252 C9
- 0253 E8
- 0254 E5
- 0255 E8
- 0278-A B5
- 0278-B C4
- 1810 B9
- 2171 C7
- 2172 D7
- 2173 D6
- 2174 C7
- 2175 B8
- 2176 F6
- 2177 F6
- 2178 F6
- 2179 E6
- 3142 B7
- 3143 B7
- 3144 C7
- 3145 C8
- 3146 D7
- 3147 D7
- 3148 E6
- 3149 F6
- 6171 B8
- 9162 D8
- F150 C8
- F151 B8
- F152 D7
- F154 F5
- I165 B7
- I166 C7
- I167 D6
- I168 E8
- I169 E5
- I170 E5
- I171 E6
- I172 E7
- I173 F5
- I174 F5
- I175 F6
- I176 F7
- I177 F8
- SG02 B7
- SG03 C7
- SG04 D6
- SG06 F7
- SG07 F7

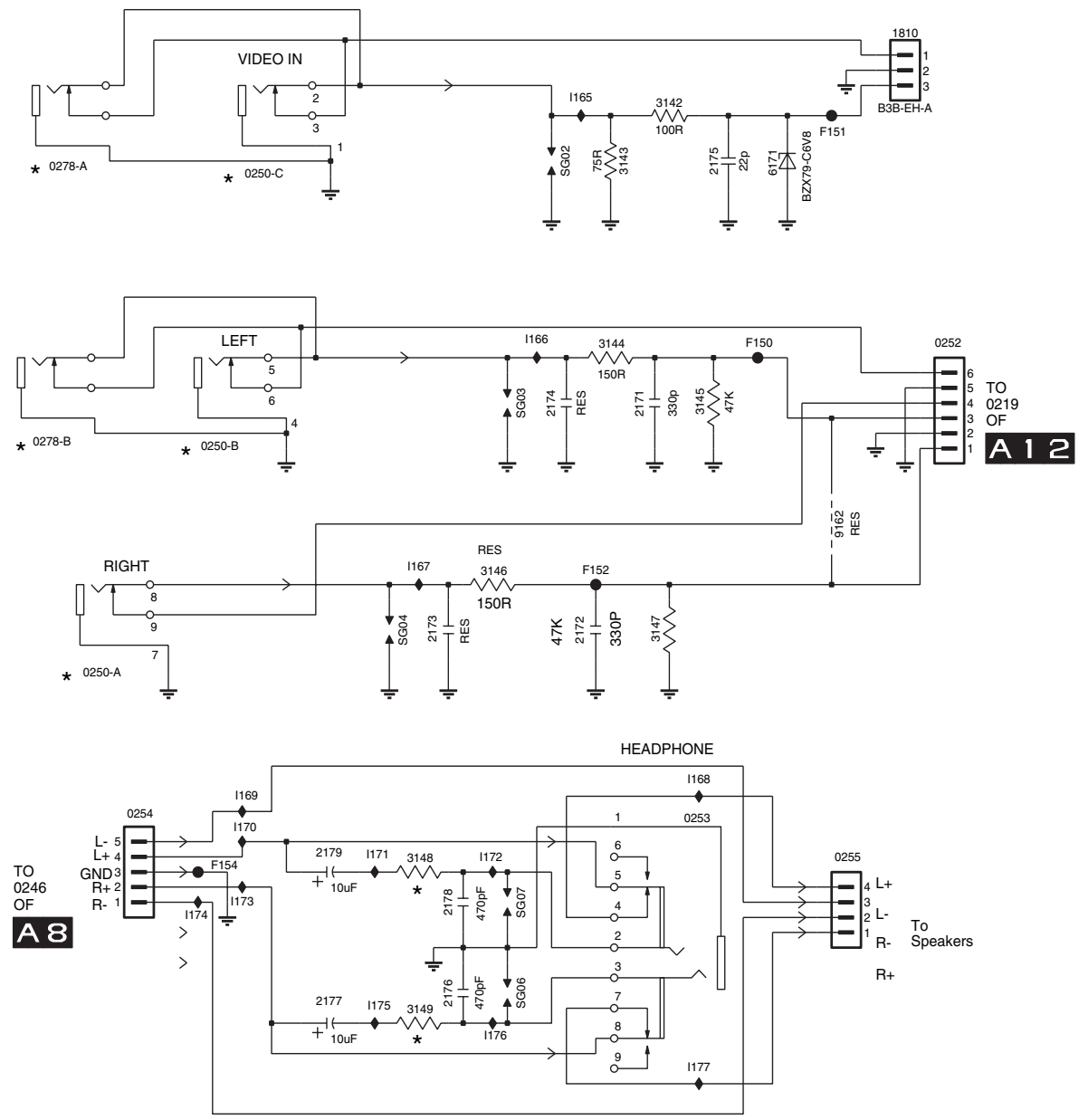

MULTIPLE BOARD 12NC : 3141\_053\_31160

SINGLE BOARD 12NC : 3141\_053\_31150

3141 053 3115.2

G\_13933\_017.eps  
050506

Layout Side AV Panel (Top Side)

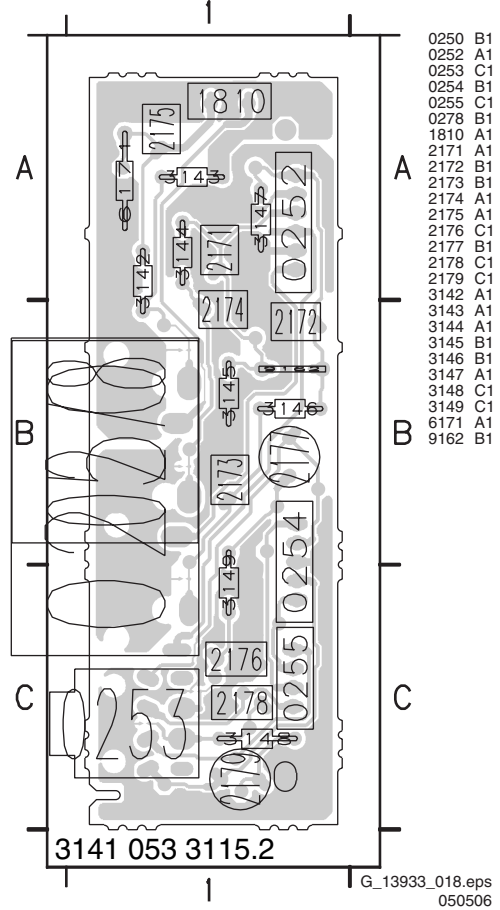

Layout Side AV Panel (Bottom Side)

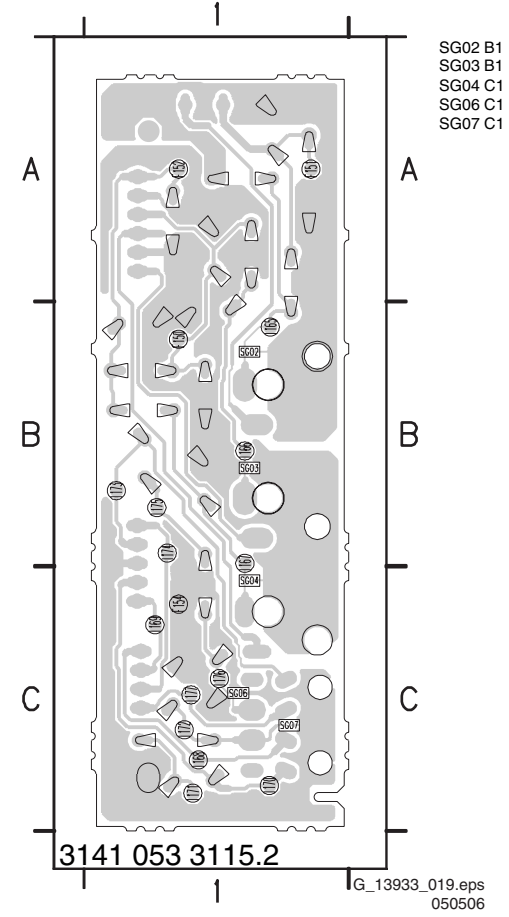

**Top Control Panel**

1010 A1 1012 B3 1014 B2 3011 A2 3013 A3 3015 A3  
 1011 B3 1013 B2 3010 A1 3012 A2 3014 A3 3016 A3

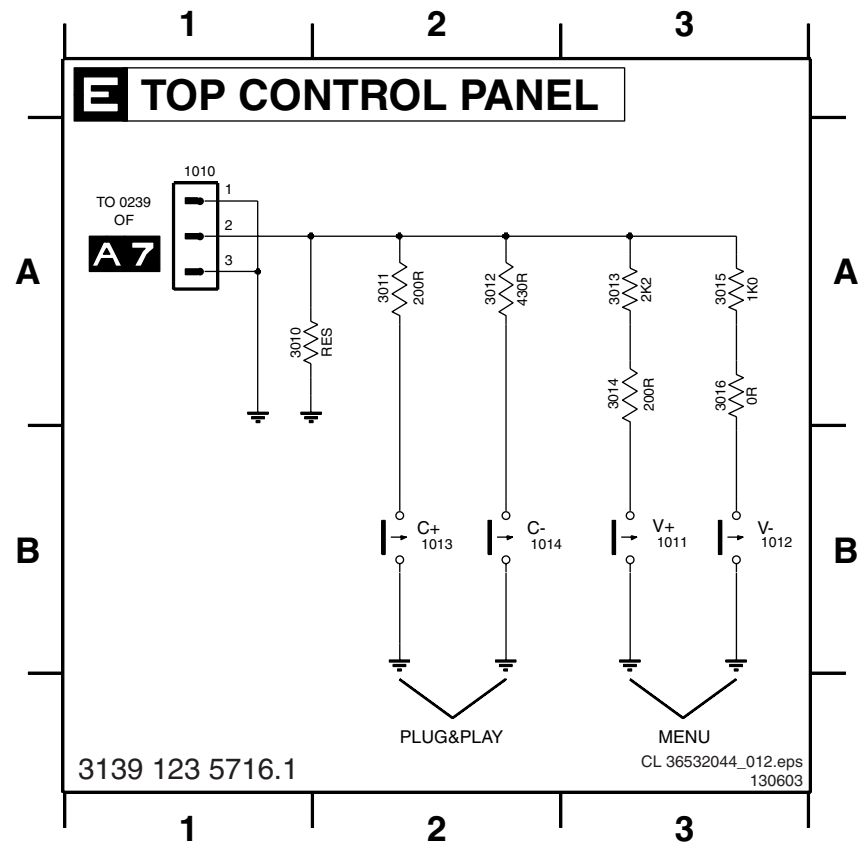

3139 123 5716.1

CL 36532044\_012.eps  
130603

**Layout Top Control Panel (Bottom Side)**

3010 A1 3012 B2 3014 A1 3016 A2  
 3011 A1 3013 A1 3015 A2

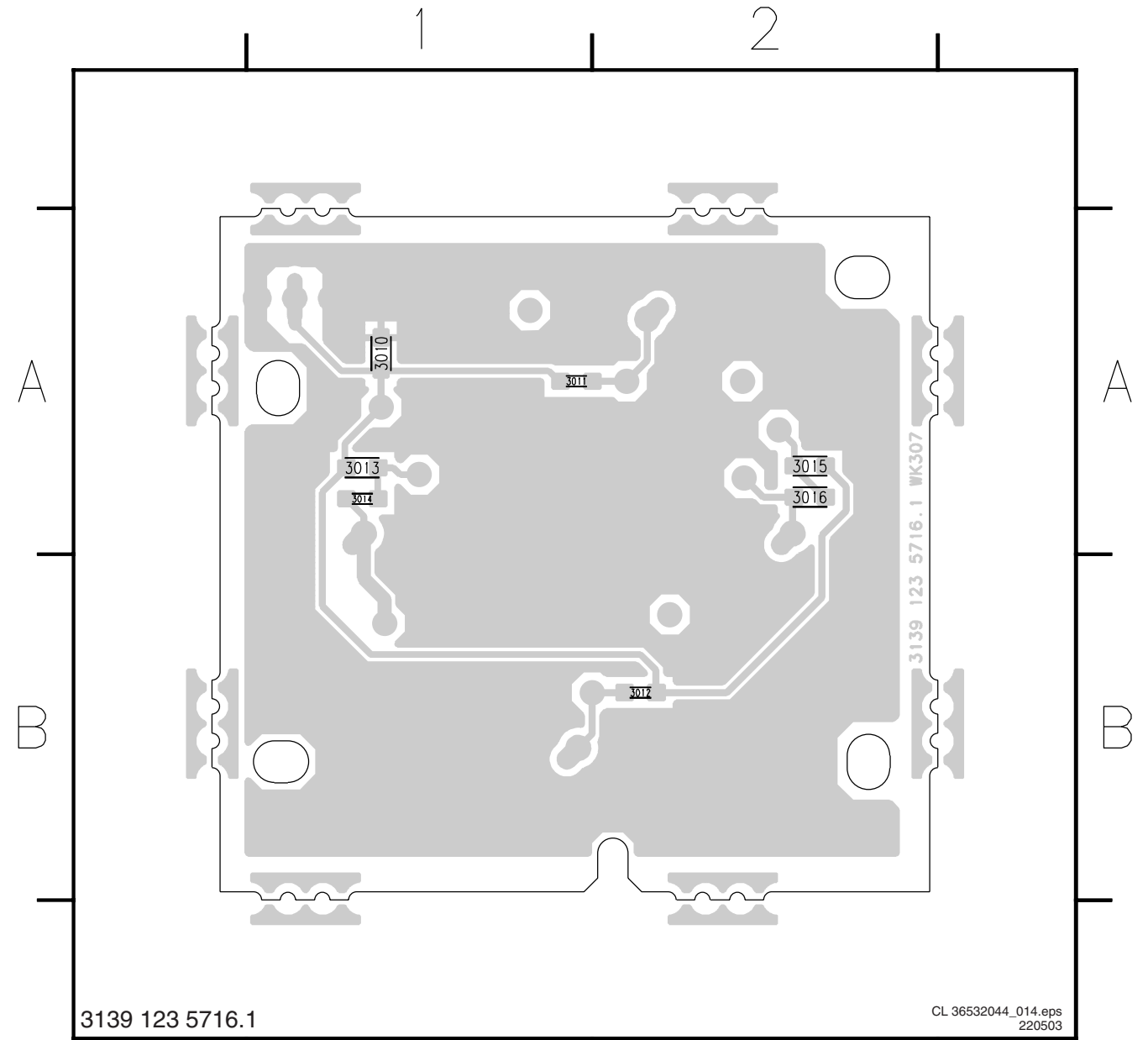

3139 123 5716.1

CL 36532044\_014.eps  
220503

**Layout Top Control Panel (Top Side)**

1010 A2 1012 A1 1014 B1  
 1011 A2 1013 A1

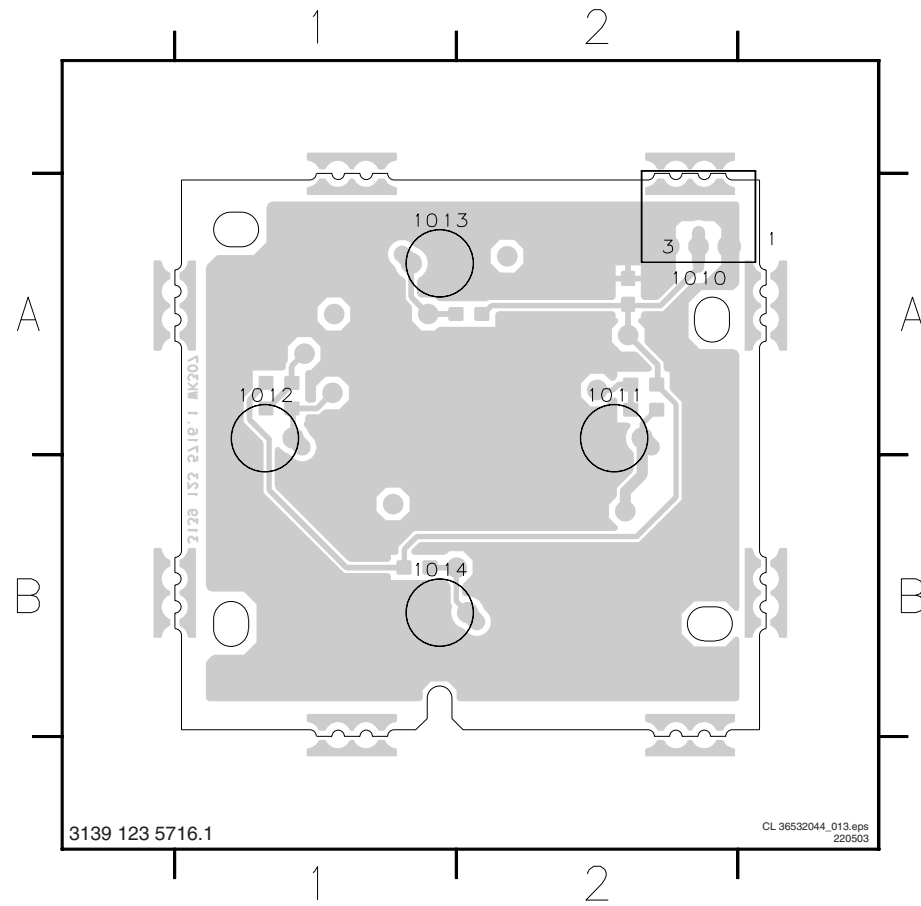

3139 123 5716.1

CL 36532044\_013.eps  
220503

## 8. Alignments

### Index of this chapter:

- 8.1 General Alignment Conditions
- 8.2 Hardware Alignments
- 8.3 Software Alignments and Settings

**Note:** The Service Default Alignment Mode (SDAM) is described in the "Service Modes, Error Codes and Fault Finding" section. SDAM menu navigation is performed by using the MENU UP, MENU DOWN, MENU LEFT, and MENU RIGHT keys of the remote control transmitter.

### 8.1 General Alignment Conditions

Perform all electrical adjustments under the following conditions:

- AC voltage and frequency: according to country's standard.
- Connect the television set to the AC power via an isolation transformer.
- Allow the television set to warm up for approximately 20 minutes.
- Measure the voltages and waveforms in relation to chassis ground (with the exception of the voltages on the primary side of the power supply). Never use heatsinks as ground.
- Test probe:  $R_i > 10 \text{ M ohm}$ ;  $C_i < 2.5 \text{ pF}$ .
- Use an isolated trimmer/screwdriver to perform the alignments.

### 8.2 Hardware Alignments

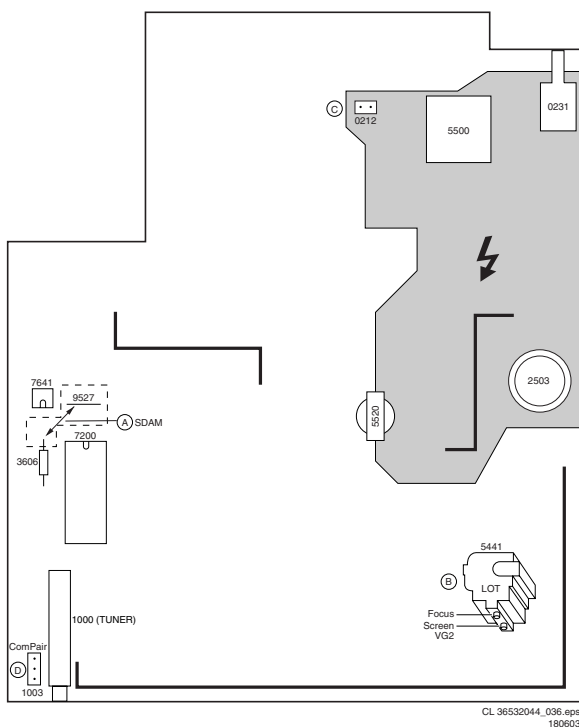

Figure 8-1 Top view family board

#### 8.2.1 Vg2 Adjustment

1. Activate SDAM by pressing the following key sequence on the remote control transmitter: 0 6 2 5 9 6 directly followed by the MENU button (do not allow the display to time out between entries while keying the sequence).
2. Use the MENU UP/DOWN keys to highlight the WHITE TONE sub menu.

3. Press the MENU LEFT/RIGHT key to enter the WHITE TONE sub menu.
4. In the WHITE TONE sub menu, press the MENU UP/DOWN keys to select NORMAL RED, NORMAL GREEN, or NORMAL BLUE.
5. Use the MENU LEFT/RIGHT keys to set the values of NORMAL RED, NORMAL GREEN and NORMAL BLUE to '40'.
6. Press the MENU button twice to enter the normal user menu.
7. In the normal user menu, use the MENU UP/DOWN keys to highlight the PICTURE sub menu (if necessary).
8. Press the MENU LEFT/RIGHT keys to enter the PICTURE sub menu.
9. Use the MENU UP/DOWN keys to select CONTRAST. Be sure to record the current value of CONTRAST.
10. Use the MENU LEFT/RIGHT keys to set the value of CONTRAST to '0'.
11. Use the MENU UP/DOWN keys to select BRIGHTNESS. Be sure to record the current value of BRIGHTNESS.
12. Use the MENU LEFT/RIGHT keys to set the value of BRIGHTNESS to minimum (OSD just visible in a dark room).
13. Press the MENU button twice to return to the top level SDAM menu.
14. Press the OSD/STATUS button to hide the SDAM onscreen display ("S" indication remains visible). This, to avoid interferences during the waveform measurements
15. Connect the RF output of a video pattern generator to the antenna input, and input a 'black picture' test pattern to the television set.
16. Set the oscilloscope to 50 V/div and the time base to 0.2 milliseconds (external triggering on the positive vertical pulse with a 10:1 probe).
17. Ground the scope at the CRT panel and connect a 100:1 probe to one of the cathodes of the picture tube socket (pin 7= Red, pin 9= Green, and pin 3= Blue, see also schematic diagram B1). Measure the level of the black current measuring pulses. These are the second line (Red), third line (Green), and fourth line (Blue) directly after the frame blanking (see figure "V\_cut-off").  
**Remark:** This chassis is using a TDA93XX UOC series. These use two different measuring pulses at each of the R, G, and B outputs. The above-mentioned level applies to the pulse with the lowest level of each gun.
18. Select the cathode with the highest  $V_{dc}$  value for the alignment. Adjust the  $V_{cut-off}$  of this gun with the SCREEN potentiometer (see figure "Top view family board") on the LOT to the correct value (see table "Vg2 alignment values").
19. Press the OSD/STATUS button to display the SDAM onscreen display.
20. Press the MENU button to enter the normal user menu.
21. In the normal user menu, use the MENU UP/DOWN keys to highlight the PICTURE sub menu (if necessary).
22. Press the MENU LEFT/RIGHT keys to enter the PICTURE sub menu.
23. Use the MENU UP/DOWN keys to select CONTRAST.
24. Use the MENU LEFT/RIGHT keys to reset the value of CONTRAST to the original value.
25. Use the MENU UP/DOWN keys to select BRIGHTNESS.
26. Use the MENU LEFT/RIGHT keys to reset the value of BRIGHTNESS to the original value.
27. Press the MENU button twice to return to the top level SDAM menu.
28. Use the POWER button on the remote control transmitter or the POWER button on the television set to turn off the television set. This will save the changes made in SDAM.

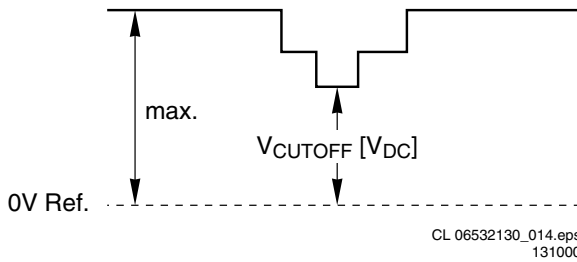

Figure 8-2 V\_cutoff

Table 8-1 Vg2 alignment values

Screen Size	Cut-off point (V)
14RF	+135 V ± 4 V
20V	+140 V ± 4 V
20RF	+140 V ± 4 V
27V	+140 V ± 4 V

8.2.2 Focusing

1. Connect the RF output of a video pattern generator to the antenna input.
2. Input a circle or crosshatch test pattern to the television set.
3. Press the SMART PICTURE button on the remote control transmitter repeatedly to choose NATURAL (or MOVIES) picture mode.
4. Adjust the FOCUS potentiometer (see figure "Top view family board") until the vertical lines near the left and right sides of the screen, and near the horizontal center of the screen, are at minimum width without visible haze.

8.3 Software Alignments and Settings

The following options are performed in the Service Default Alignment Mode (SDAM). SDAM is described in the "Service Modes, Error Codes and Fault Finding" section.

The following alignments are explained:

1. OPTIONS
2. TUNER
3. WHITE TONE
4. GEOMETRY
5. AUDIO

8.3.1 OPTIONS

Options are used to control the presence or absence of certain features and hardware.

**Note:** Each option byte controls several features of the television set; therefore, before changing option byte information, it is important to record the current option byte values. This ensures that the television features can be restored to the original settings, if necessary.

**How to Change an Option Byte**

An Option Byte represents a number of different options. Changing these bytes directly makes it possible to set all options very fast. All options are controlled via seven option bytes. Select the option byte (OP 1.. OP 7) with the MENU UP/ DOWN keys, and enter the new value.

1. Activate SDAM by pressing the following key sequence on the remote control transmitter: 0 6 2 5 9 6 directly followed by the MENU button (do not allow the display to time out between entries while keying the sequence).
2. Use the MENU UP/DOWN keys to highlight the OPTIONS sub menu.

3. Press the MENU LEFT or MENU RIGHT key to enter the OPTIONS sub menu.
4. In the OPTIONS sub menu, press the MENU UP/DOWN keys to select 'OP 1' through 'OP 7'.
5. Use the number keys on the remote control transmitter to enter a new value for the selected option byte. The value must be entered as a three-digit value (for example, '4' would be entered as '0 0 4').
6. The selected value must be between '0' and '255'.
7. When all desired changes to the option bytes are made, press the MENU button to return to the top level SDAM menu. This will save changes to the option byte settings.
8. To ensure the option byte changes take effect:
  - Turn the television set 'off' by using the 'POWER' button on the remote control transmitter or the local keyboard.
  - Disconnect the television set from AC power for at least ten seconds.
  - Reconnect the television set to AC power.
  - Turn the television set 'on' by using the 'POWER' button on the remote control transmitter or the local keyboard.

Leaving the OPTION submenu saves the changes in the Option Byte settings. Some changes will only take effect after the set has been switched OFF and ON with the mains switch (cold start).

**How to Calculate the Value of an Option Byte**

Calculate an Option Byte value (OP 1 .. OP 7) in the following way:

1. Check the status of the single option bits (OB): are they enabled (1) or disabled (0).
2. When an option bit is enabled (1), it represents a certain value (see first column "value between brackets" in table below). When an option bit is disabled, its value is 0.
3. The total value of an Option Byte is formed by the sum of its eight option bits. See second table below for the correct Option Bytes per type number.

Bit (value)	OP1	OP2	OP3	OP4	OP5	OP6	OP7
0 (1)	OB10	OB20	OB30	OB40	OB50	OB60	OB70
1 (2)	OB11	OB21	OB31	OB41	OB51	OB61	OB71
2 (4)	OB12	OB22	OB32	OB42	OB52	OB62	OB72
3 (8)	OB13	OB23	OB33	OB43	OB53	OB63	OB73
4 (16)	OB14	OB24	OB34	OB44	OB54	OB64	OB74
5 (32)	OB15	OB25	OB35	OB45	OB55	OB65	OB75
6 (64)	OB16	OB26	OB36	OB46	OB56	OB66	OB76
7 (128)	OB17	OB27	OB37	OB47	OB57	OB67	OB77
<b>Total:</b>	<b>Sum</b>	<b>Sum</b>	<b>Sum</b>	<b>Sum</b>	<b>Sum</b>	<b>Sum</b>	<b>Sum</b>

CL\_36532044\_037.eps 160603

Figure 8-3 Option Byte calculation

Table 8-2 Options settings

Typenumber	OP1	OP2	OP3	OP4	OP5	OP6	OP7
20L140/37C							
20L145/37C	65	215	65	162	196	201	0
14RFL150/37C							
20PT6331/37C	65	215	65	162	192	201	0
20PT6431/37C	65	215	65	162	204	201	0
20MS3341/37C	65	215	65	2	192	73	0
20PT6341/37							
20PT5441/37							
14PT6441/37	65	215	65	162	204	201	0
20PT6441/37							
20PT6245/37							
27PT5445/37	65	215	65	130	204	201	0
27MT3305/17	65	211	65	130	196	201	0

**Option Bit Assignment**

Following are the option bit assignments for all L03 software clusters.

**Table 8-3 Option Bit Assignment**

Option Byte	Option Bit Definition				
OP #	Assignment	Bit = [0]	Bit = [1]	Default setting	
1	OBx0	CHINA or NTSC_ONLY	Tuning is not for China set or NTSC only set, or this option bit is not applicable	Tuning is for China set or NTSC only set	LATAM & NAFTA: 0 for other sets, 1
	OBx1	VIRGIN_MODE	Virgin mode is disabled or not applicable	Virgin mode is enabled. Plug and Play menu item will be displayed to perform installation at the initial startup of the TV when VIRGIN_MODE is set to 1. After installation is finished, this option bit will be automatically set to 0	LATAM & NAFTA: 0
	OBx2	UK_PNP	UK's default Plug and Play setting is not available or not applicable	UK's default Plug and Play setting is available. When UK_PNP and VIRGIN_MODE are set to 1 at the initial setup, LANGUAGE = ENGLISH, COUNTRY = GREAT BRITAIN and after exiting from menu, VIRGIN_MODE will be set automatically to 0 while UK_PNP remains 1	LATAM & NAFTA: 0
	OBx3	ACI	ACI feature is disabled or not applicable	ACI feature is enabled	LATAM & NAFTA: 0.
	OBx4	ATS (EU), or FINE_TUNING (NAFTA), or LANGUAGE_MALAY (AP)	Feature is disabled or not applicable	Feature is enabled	LATAM & NAFTA: 0
	OBx5	LNA	Auto Picture Booster is not available or not applicable	Auto Picture Booster is available	LATAM & NAFTA: 0
	OBx6	FM_RADIO	FM radio feature is disabled or not applicable	FM radio feature is enabled	LATAM & NAFTA: 0
OBx7	PHILIPS_TUNER	ALPS / MASCO compatible tuner is in use	Philips compatible tuner is in use	LATAM & NAFTA: 0	
2	OBx0	HUE	Hue/Tint Level is disabled or not applicable	Hue/Tint Level is enabled	LATAM & NAFTA: 1
	OBx1	COLOR_TEMP	Color Temperature is disabled or not applicable	Color Temperature is enabled	LATAM & NAFTA: 1
	OBx2	CONTRAST_PLUS	Contrast+ is disabled or not applicable	Contrast+ is enabled	LATAM & NAFTA: 1
	OBx3	TILT	Rotate Picture is disabled or not applicable	Rotate Picture is enabled	LATAM & NAFTA: 0
	OBx4	NOISE_REDUCTION	Noise Reduction (NR) is disabled or not applicable	Noise Reduction (NR) is enabled	LATAM & NAFTA: 0
	OBx5	CHANNEL_NAMING	Name FM Channel is disabled or not applicable	Name FM Channel is enabled	LATAM & NAFTA: 0. (Note: Name FM channel can be enabled only when FM_RADIO= 1)
	OBx6	SMART_PICTURE	Smart Picture is disabled or not applicable	Smart Picture is enabled	LATAM & NAFTA: 1
OBx7	SMART_SOUND	Smart Sound is disabled or not applicable	Smart Sound is enabled	LATAM & NAFTA: 0 for mono sets, 1 for stereo sets.	
3	OBx0	AVL	AVL is disabled or not applicable	AVL is enabled	LATAM & NAFTA: 1
	OBx1	WSSB or HOME_CINEMA	WSSB is disabled or not applicable	WSSB is enabled	LATAM & NAFTA: 0. (Note: This option bit can be set to 1 only when WIDE_SCREEN= 1)
	OBx2	WIDE_SCREEN	Software is used for 4:3 set or not applicable	Software is used for 16:9 set	LATAM & NAFTA: 0
	OBx3	Virtual Dolby			LATAM & NAFTA: 1
	OBx4	MSP34X5_VOL_CTRL			LATAM & NAFTA: 0. (Note: For 2 x 10 W sets only)
	OBx5	COMPRESS_16_9	COMPRESS 16:9 selection is not applicable. Item should not be in the FORMAT menu list	COMPRESS 16:9 selection is applicable. Item should not be in the FORMAT menu list	LATAM & NAFTA: 0
	OBx6	EXPAND_4_3	Expand 4:3 selection is not applicable. Item should not be in the FORMAT menu list,	Expand 4:3 selection is applicable. Item should be in the FORMAT menu list	LATAM & NAFTA: 1
OBx7	EW_FUNCTION	EW function is disabled. In this case, only Expand 4:3 is allowed, Compress 16:9 is not applicable	EW function is enabled. In this case, both Expand 4:3 and Compress 16:9 are applicable.	LATAM & NAFTA: 0	
4	OBx0	STEREO_NON_DBX	For AP_NTSC, chip TDA 9853 is not present	For AP_NTSC, chip TDA 9853 is present	LATAM & NAFTA: 0 for mono sets, 1 for stereo sets.
	OBx1	STEREO_DBX	For AP_NTSC, chip MSP 3445 is not present	For AP_NTSC, chip MSP 3445 is present	LATAM & NAFTA: 0
	OBx2	STEREO_PB or KOREAN_2CS	For AP_PAL, chip MSP3465 is not present	For AP_PAL, chip MSP3465 is present	LATAM & NAFTA: 0
	OBx3	STEREO_NICAM_2C S	For EU and AP_PAL, chip MSP 3415 is not present	For EU and AP_PAL, chip MSP 3415 is present	LATAM & NAFTA: 0
	OBx4	OB44: DELTA_VOLUME	Delta Volume Level is disabled or not applicable	Delta Volume Level is enabled	
	OBx5	OB45: ULTRA_BASS	Ultra Bass is disabled or not applicable	Ultra Bass is enabled	LATAM & NAFTA: 0 for mono sets, 1 for stereo sets
	OBx6	VOLUME_LIMITER	Volume Limiter Level is disabled or not applicable	Volume Limiter Level is enabled	LATAM & NAFTA: 0
OBx7	OB47: INCR_SUR	Incredible Surround feature is disabled	Incredible Surround feature is enabled	LATAM & NAFTA: 0 for mono sets, 1 for stereo sets.	

Option Byte	Option Bit Definition				
5	OBx0	PIP or CLOCK	Feature is disabled or not applicable	Feature is enabled	LATAM & NAFTA: 0
	OBx1	HM	HM is disabled or not applicable	HM is enabled	LATAM & NAFTA: 0 for stereo sets, 1 for mono sets.
	OBx2	SVHS	SVHS source is not available	SVHS source is available	LATAM & NAFTA: 0. (Note: This option bit is not applicable for EU)
	OBx3	CVI	CVI source is not available	CVI source is available	
	OBx4	AV3	Side/Front AV3 source is not present	Side/Front AV3 source is present	LATAM & NAFTA: 0.
	OBx5	AV2	AV2 source is not present	AV2 source is present	LATAM & NAFTA: 0. (Note: For EU, when AV2=1, both EXT2 and SVHS2 should be included in the OSD loop)
	OBx6	AV1	AV1 source is not present	AV1 source is present	LATAM & NAFTA: 1
	OBx7	NTSC_PLAYBACK	NTSC playback feature is not available	NTSC playback feature is available	LATAM & NAFTA: 1
6	OBx0	BASS_TREBLE	Feature is not available	Feature is available	LATAM & NAFTA: 0 for mono sets, 1 for stereo sets
	OBx1	SMART_TEXT	Smart Text Mode and Favorite Page are disabled or not applicable	Smart Text Mode and Favorite Page are enabled	LATAM & NAFTA: 0
	OBx2	SMART_LOCK	Child Lock and Lock Channel are disabled or not applicable for EU	Child Lock and Lock Channel are enabled for EU	LATAM & NAFTA: 1
	OBx3	VCHIP (LATAM & NAFTA & NAFTA) / TXT_1PG (EU)	Feature is disabled	Feature is enabled	LATAM & NAFTA: 0.
	OBx4	WAKEUP_CLOCK	Wake up clock feature is disabled or not applicable	Wake up clock feature is enabled	LATAM & NAFTA: 0
	OBx5	SMART_CLOCK	Smart Clock Using Teletext and Smart Clock Using PBS is disabled or not applicable	Smart Clock Using Teletext and Smart Clock Using PBS is enabled. For NAFTA, menu item AUTOCHRON is present in the INSTALL submenu	LATAM & NAFTA: 0
	OBx6	SMART_SURF	Smart Surf feature is disabled or not applicable	Smart Surf feature is enabled	LATAM & NAFTA: 1
	OBx7	PERSONAL_ZAPPING	Personal Zapping feature is disabled or not applicable	Personal Zapping feature is enabled	LATAM & NAFTA: 0
7	OBx0	SYSTEM_LT_1 and SYSTEM_LT_2	These two option bits are allocated for LATAM system selection. (00: NTSC-M ; 01: NTSC-M, PAL-M ; 10: NTSC-M, PAL-M, and PAL-N ; 11: NTSC-M, PAL-M, PAL-N, and PAL-BG)		
	OBx1				
	OBx2	SOUND_SYSTEM_AP	OB70,OB71,OB72;These three option bits are allocated for AP_PAL sound system selection. (000: BG ; 001: BG / DK ; 010: I / DK ; 011: BG / I / DK ; 100: BG / I / DK / M)		
	OBx3	COLOR_SYSTEM_AP (This option bit is allocated for AP-PAL color system selection)	Auto, PAL 4.43, NTSC 4.43, and NTSC 3.58	Auto, PAL 4.43, NTSC 4.43, NTSC 3.58, and SECAM	LATAM & NAFTA: 0
	OBx4	SIGNAL_STRENGTH / DVD WAKEUP TIMER (DVD COMBI), 3D_COMBFILTER (NAFTA)			LATAM & NAFTA: 1.
	OBx5	LNA_PP (for L01 AP cluster), VOICE_CONTROL			LATAM & NAFTA: 0
	OBx6	ACTIVE_CONTROL			LATAM & NAFTA: 1
	OBx7	TIME_WIN1	The time window is set to 1.2 s	The time window is set to 2 s	LATAM & NAFTA: 0 (Note: The time-out for all digit entries depends on this setting)

### 8.3.2 Tuner

**Note:** Described alignments are only necessary when the NVM (part reference number 7641) is replaced.

#### IFPLL

This adjustment is auto-aligned. Therefore, no action is required (default= "30").

#### AGC (AGC take over point)

- Connect the RF output of a video pattern generator to the antenna input.
- Input a color bar test pattern to the television set.
- Set the amplitude of the video pattern generator to 10 mV and set the frequency to 475.25 MHz (PAL/SECAM) or 61.25 MHz (NTSC).
- Connect a DC multimeter to pin 1 of the tuner (item 1000 on the main chassis).
- Activate SDAM by pressing the following key sequence on the remote control transmitter: 0 6 2 5 9 6 directly followed by the MENU button (do not allow the display to time out between entries while keying the sequence).
- Use the MENU UP/DOWN keys to highlight the TUNER sub menu.
- Press the MENU LEFT/RIGHT keys to enter the TUNER sub menu.
- Use the MENU UP/DOWN keys to select AGC.
- Use the MENU LEFT/RIGHT keys to adjust the AGC value (default value is "32") until the DC-voltage at pin 1 of the tuner lies is 3.3 V.
- Press the MENU button to return to the top level SDAM menu.
- To ensure the AGC change takes effect:
  - Turn the television set 'off' by using the 'POWER' button on the remote control transmitter or the local keyboard.
  - Disconnect the television set from AC power for at least ten seconds.

- Reconnect the television set to AC power.
- Turn the television set 'on' by using the 'POWER' button on the remote control transmitter or the local keyboard.

### SL (Slicing Level)

This adjustment sets the sync slicing level for non-standard signals. You must turn it 'on' to have no picture instability in premium decoded cable channels.

- OFF: slicing level dependent on noise level.
- ON: fixed slicing level of 70 %.

To adjust SL:

1. Activate SDAM by pressing the following key sequence on the remote control transmitter: 0 6 2 5 9 6 directly followed by the MENU button (do not allow the display to time out between entries while keying the sequence).
2. Use the MENU UP/DOWN keys to highlight the TUNER sub menu.
3. Press the MENU LEFT/RIGHT keys to enter the TUNER sub menu.
4. Use the MENU UP/DOWN keys to select SL.
5. Use the MENU LEFT/RIGHT keys to toggle SL 'Off' and 'On'.
6. Press the MENU button to return to the top level SDAM menu.
7. To ensure the SL setting is saved:
  - Turn the television set 'off' by using the 'POWER' button on the remote control transmitter or the local keyboard.
  - Disconnect the television set from AC power for at least ten seconds.
  - Reconnect the television set to AC power.
  - Turn the television set 'on' by using the 'POWER' button on the remote control transmitter or the local keyboard.

### CL (Cathode Drive Level)

Fixed value is "7".

### 8.3.3 White Tone

The values of the 'black cut-off level' can be adjusted in the 'WHITE TONE' sub menu. Normally, no alignment is needed for 'WHITE TONE', and the given default values are used.

Default settings for **NORMAL** (color temperature= 11500 K):  
 NORMAL RED = 22  
 NORMAL GREEN = 21  
 NORMAL BLUE = 26

To adjust NORMAL RED, NORMAL GREEN, and NORMAL BLUE:

1. Connect the RF output of a video pattern generator (e.g. PM5418) to the antenna input.
2. Set the amplitude of the video pattern generator to at least 1 mV and set the frequency to 475.25 MHz (PAL/SECAM) or 61.25 MHz (NTSC).
3. Input a "100 IRE white" pattern to the television set.
4. Activate SDAM by pressing the following key sequence on the remote control transmitter: 0 6 2 5 9 6 directly followed by the MENU button (do not allow the display to time out between entries while keying the sequence).
5. Use the MENU UP/DOWN keys to highlight the WHITE TONE sub menu.
6. Press the MENU LEFT/RIGHT keys to enter the WHITE TONE sub menu.
7. Use the MENU UP/DOWN keys to select NORMAL RED, NORMAL GREEN, or NORMAL BLUE.
8. Set the Minolta CA100 color analyzer (or equivalent) in RGB mode, and set all color temperature settings to their default values.

9. Place the color sensor of the meter in the middle of the screen.
10. Set the meter in "T-dUV-Y" mode, and set CONTRAST to make the light output "Y" on the meter  $90 \text{ nit} \pm 15\%$
11. Use the MENU LEFT/RIGHT keys to adjust the value of NORMAL GREEN and/or NORMAL BLUE.
12. When all desired changes to the WHITE TONE sub menu values are made, press the MENU button to return to the top level SDAM menu.
13. To ensure the WHITE TONE settings are saved:
  - Turn the television set 'off' by using the 'POWER' button on the remote control transmitter or the local keyboard.
  - Disconnect the television set from AC power for at least ten seconds.
  - Reconnect the television set to AC power.
  - Turn the television set 'on' by using the 'POWER' button on the remote control transmitter or the local keyboard.

### 8.3.4 Geometry

#### Introduction

The geometry alignment menu contains several items for correct picture geometry alignment.

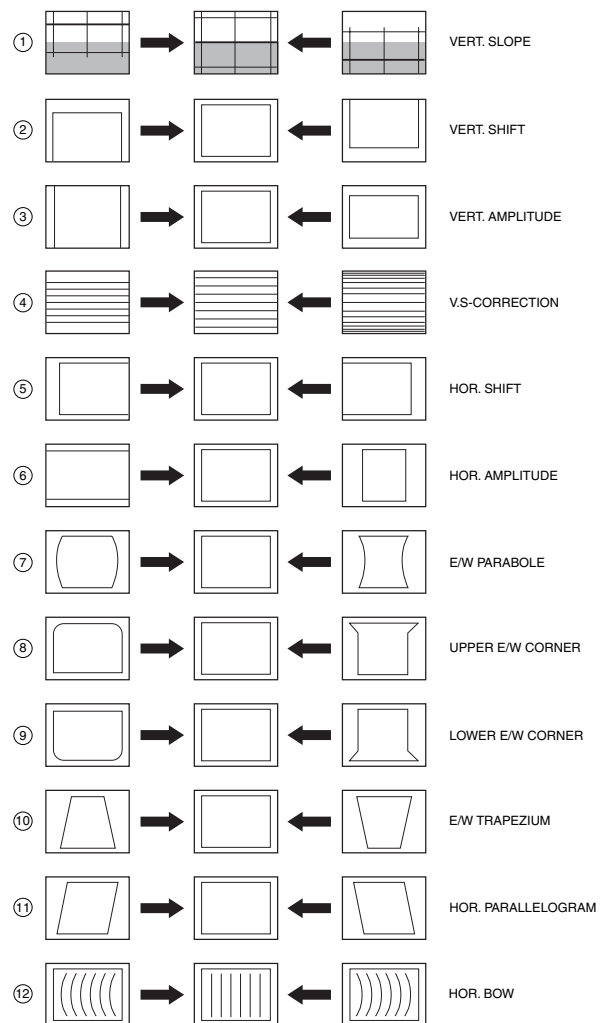

CL 16532044\_022.eps  
140501

Figure 8-4 Geometry alignments

1. Connect the RF output of a video pattern generator to the antenna input.
2. Input a crosshatch test pattern to the television set.
3. Set the amplitude of the video pattern generator to at least 1 mV and set the frequency to 475.25 MHz (PAL/SECAM) or 61.25 MHz (NTSC).

4. Press the SMART PICTURE button on the remote control transmitter repeatedly to choose PERSONAL or MOVIES picture mode.
5. Activate SDAM by pressing the following key sequence on the remote control transmitter: 0 6 2 5 9 6 directly followed by the MENU button (do not allow the display to time out between entries while keying the sequence).
6. Use the MENU UP/DOWN keys to highlight the GEOMETRY sub menu.
7. Press the MENU LEFT/RIGHT keys to enter the GEOMETRY sub menu.
8. Use the MENU UP/DOWN keys to highlight either the HORIZONTAL sub menu or the VERTICAL sub menu.
9. Press the MENU LEFT/RIGHT keys to enter either the HORIZONTAL sub menu or the VERTICAL sub menu.
10. Use the MENU UP/DOWN keys to select items in the HORIZONTAL sub menu or the VERTICAL sub menu.
11. Use the MENU LEFT/RIGHT keys to adjust the values of items in the HORIZONTAL and VERTICAL sub menus.
12. When all desired changes to the HORIZONTAL and VERTICAL sub menu values are made, press the MENU button twice to return to the top level SDAM menu.
13. To ensure the GEOMETRY settings are saved:
  - Turn the television set 'off' by using the 'POWER' button on the remote control transmitter or the local keyboard.
  - Disconnect the television set from AC power for at least ten seconds.
  - Reconnect the television set to AC power.
  - Turn the television set 'on' by using the 'POWER' button on the remote control transmitter or the local keyboard.

The following alignments can be performed in the GEOMETRY sub menu:

#### Horizontal Alignments:

- Horizontal Shift (HSH). Select Horizontal Shift to center the picture on the screen.
- Picture Width (PW). Aligns the width of the picture.

#### Vertical Alignments:

- Vertical slope (VSL). Aligns the picture so the proportions are the same at the top and bottom of the screen. This alignment must be performed first, before all other vertical alignments. Turning SBL, 'on' will assist in performing this alignment.
- Vertical Amplitude (VAM). Aligns the height of the picture (other vertical alignments are NOT compensated).
- Vertical S-Correction (VSC). Aligns the vertical linearity, so that the vertical intervals of the grid-patterns are the same over the entire height of the screen.
- Vertical Shift (VSH). Aligns the vertical center of the picture to the vertical center of the CRT. After performing this alignment, it may be necessary to perform the VAM alignment again.
- Service blanking (SBL). Turns the blanking of the lower half of the screen 'on' or 'off' (to be used in combination with the vertical slope alignment).

#### Methods of Adjustment

##### Vertical Amplitude and Position

1. Select SERVICE BLANKING (SBL) and set it to 1. The lower half of the picture will be blanked.
2. Press the MENU UP/DOWN buttons to select VERTICAL SLOPE (VSL).
3. Align VSL to start the blanking exactly at the horizontal white line at the center of the test circle (align the bottom of the screen so that castellations just disappear).
4. Press the MENU UP/DOWN buttons to select SBL and set it back to 0. The full picture reappears.
5. Select VERTICAL AMPLITUDE (VAM) and align the picture height to approximately 13.0 - 13.1 blocks (align the top of the screen so that castellations just disappear).

6. Select VERTICAL SHIFT (VSH) and align for vertical centering of the picture on the screen.
7. Repeat the last two steps if necessary.

#### Horizontal Phase

1. Set PW to "0".
2. Select Horizontal Shift (HSH) to center the picture on the screen.

#### Horizontal and Vertical Shift Offset for NTSC (TRINOMA and PAL chassis)

1. Align the set for VSH and HSH (according to above mentioned procedures) with a PAL system signal.
2. Change the signal to NTSC system and adjust HORIZONTAL SHIFT OFFSET (H60) and VERTICAL SHIFT OFFSET (V60) to center the picture on the screen.
3. Repeat if necessary.

The table below lists the default GEOMETRY values for the different television sets.

**Table 8-4 Default geometry values**

Alignment	Description	Value
PW 31	Picture Width	1F
HSH	Horizontal Shift	35
VSL	Vertical Slope	33
VAM	Vertical Amplitude	26
VSC	Vertical S orrection	23
VSH	Vertical Shift	31

### 8.3.5 Audio

Necessary measuring equipment:

- MTS (Multi-channel Television Sound) generator (e.g. Fluke 54200).
- AC millivolt meter.

#### ILA (Input Level Alignment)

1. Activate SDAM by pressing the following key sequence on the remote control transmitter: 0 6 2 5 9 6 directly followed by the MENU button (do not allow the display to time out between entries while keying the sequence).
2. Use the MENU UP/DOWN keys to highlight the AUDIO sub menu.
3. Press the MENU LEFT/RIGHT keys to enter the AUDIO sub menu.
4. Use the MENU UP/DOWN keys to select ILA.
5. Apply a BTSC sound signal with a signal strength of 60 dBuV (1 mV<sub>rms</sub>) to the aerial input. Measure the output on pin 21 (L\_OUT) of IC7841 with an AC millivoltmeter via a Low Pass Filter (R= 10 kohm, C= 1.5 nF, measure on the capacitor).
6. Use the MENU LEFT/RIGHT keys to adjust the meter reading to 106 mV<sub>rms</sub> ± 2 mV<sub>rms</sub> (default ILA value is "31").
7. Press the MENU button to return to the top level SDAM menu.
8. To ensure the ILA setting is saved:
  - Turn the television set 'off' by using the 'POWER' button on the remote control transmitter or the local keyboard.
  - Disconnect the television set from AC power for at least ten seconds.
  - Reconnect the television set to AC power.
  - Turn the television set 'on' by using the 'POWER' button on the remote control transmitter or the local keyboard.

#### LSA (Low Separation Alignment)

1. Activate SDAM by pressing the following key sequence on the remote control transmitter: 0 6 2 5 9 6 directly followed

- by the MENU button (do not allow the display to time out between entries while keying the sequence).
2. Use the MENU UP/DOWN keys to highlight the AUDIO sub menu.
  3. Press the MENU LEFT/RIGHT keys to enter the AUDIO sub menu.
  4. Use the MENU UP/DOWN keys to select LSA.
  5. Apply a 300 Hz BTSC sound signal with a signal strength of 60 dBuV (1 mV<sub>rms</sub>) to the aerial input (only the left channel of the stereo signal). Measure the output on pin 22 (R\_OUT) of IC7841 with an AC millivoltmeter.
  6. Use the MENU LEFT/RIGHT keys to adjust the meter reading to a minimum value (default LSA value is "7" for stereo sets, and "0" for mono sets).
  7. Press the MENU button to return to the top level SDAM menu.
  8. To ensure the LSA setting is saved:
    - Turn the television set 'off' by using the 'POWER' button on the remote control transmitter or the local keyboard.
    - Disconnect the television set from AC power for at least ten seconds.
    - Reconnect the television set to AC power.
    - Turn the television set 'on' by using the 'POWER' button on the remote control transmitter or the local keyboard.

#### ***HSA (High Separation Alignment)***

1. Activate SDAM by pressing the following key sequence on the remote control transmitter: 0 6 2 5 9 6 directly followed by the MENU button (do not allow the display to time out between entries while keying the sequence).
2. Use the MENU UP/DOWN keys to highlight the AUDIO sub menu.
3. Press the MENU LEFT/RIGHT keys to enter the AUDIO sub menu.
4. Use the MENU UP/DOWN keys to select HSA.
5. Apply a 3 kHz BTSC sound signal with a signal strength of 60 dBuV (1 mV<sub>rms</sub>) to the aerial input (only the left channel of the stereo signal). Measure the output on pin 22 (R\_OUT) of IC7841 with an AC millivoltmeter.
6. Use the MENU LEFT/RIGHT keys to adjust the meter reading to a minimum value (default HSA value is "31").
7. Press the MENU button to return to the top level SDAM menu.
8. To ensure the HSA setting is saved:
  - Turn the television set 'off' by using the 'POWER' button on the remote control transmitter or the local keyboard.
  - Disconnect the television set from AC power for at least ten seconds.
  - Reconnect the television set to AC power.
  - Turn the television set 'on' by using the 'POWER' button on the remote control transmitter or the local keyboard.

## 9. Circuit Descriptions, List of Abbreviations, and IC Data Sheets

### Index of this chapter:

- 9.1 Introduction
- 9.2 Source Selection
- 9.3 Audio
- 9.4 Video
- 9.5 Synchronization
- 9.6 Deflection
- 9.7 Power Supply
- 9.8 Control
- 9.9 Abbreviation List
- 9.10 IC Data Sheets

### Notes:

- Only **new** circuits (compared to the L01.2 chassis) are described in this chapter. For the other circuit descriptions, see the manual of the L01.2L AA. This manual is available in different languages:
  - 3122 785 11800 = Spanish.
  - 3122 785 11820 = Portuguese.
- Figures can deviate slightly from the actual situation, due to different set executions.
- For a good understanding of the following circuit descriptions, please use the block diagram in chapter 6, and/or the electrical diagrams in chapter 7. Where necessary, you will find a separate drawing for clarification.

### 9.1 Introduction

The "L03" chassis is a global TV chassis for the model year 2003 and is used for TV sets with screen sizes from 14 inch to 21 inch, in Super Flat and Real Flat executions. In comparison to its predecessor (the "L01"), this chassis is further simplified: it contains economized executions of the power supply, the video processing (microprocessor), and the audio processing.

The standard architecture consists of a Main panel (called "family board"), a Picture Tube panel, a Side I/O panel, and a Top Control panel. The Main panel consists primarily of conventional components with some surface mounted devices in the audio and video processing part.

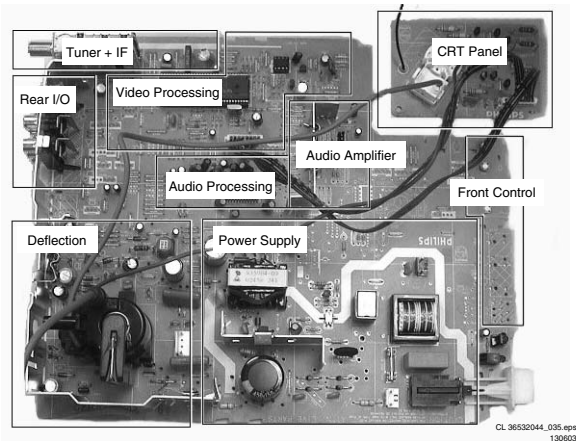

Figure 9-1 Top view family board

The functions for video processing, microprocessor (P), and CC/Teletext (TXT) decoder are combined in one IC (TDA937x), the so-called Ultimate One Chip (UOC). This chip is mounted on the component side of the main panel.

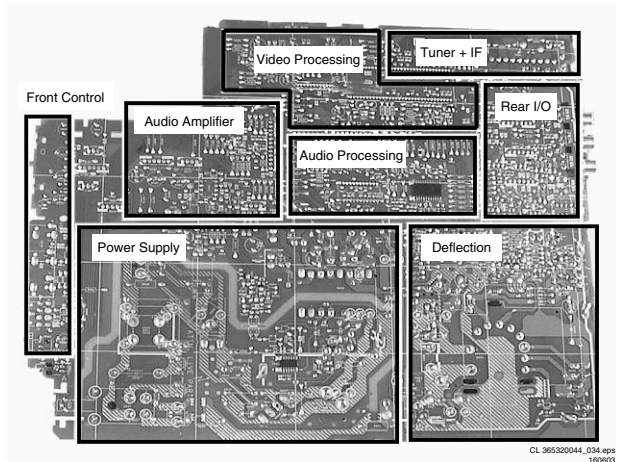

Figure 9-2 Bottom view family board

The L03 can be divided into two basic systems, i.e. mono and stereo sound. While the audio processing for the mono sound is done in the audio block of the UOC, external audio processing ICs are used for stereo sets.

The tuning system features 181 channels with on-screen display. The main tuning system uses a tuner, a microcomputer, and a memory IC mounted on the main panel. The microcomputer communicates with the memory IC, the customer keyboard, remote receiver, tuner, signal processor IC and the audio output IC via the I2C bus. The memory IC retains the settings for favorite stations, customer-preferred settings, and service / factory data. The on-screen graphics and closed caption decoding are done within the microprocessor where they are added to the main signal.

The chassis uses a Switching Mode Power Supply (SMPS) for the main voltage source. The chassis has a 'hot' ground reference on the primary side and a cold ground reference on the secondary side of the power supply and the rest of the chassis.

### 9.2 Source Selection

The Source Select is divided mainly into two types, the "Mono Source Select" and the "Stereo Source Select".

- The Mono Source Select, both audio and video, will be done entirely by the UOC and will only be able to select one external audio source.
- As for the Stereo Source Select, the Panasonic IC, which is for BTSC decoding also, has 2 audio source inputs used for source selection, whereas the UOC will take care of the video selection.

#### 9.2.1 Switching Function for Stereo I/O

##### Video Source Selection

The video source selection is done by the UOC. The video setting for LATAM / NAFTA is rather straightforward: a so-called "WYSIWYG" (what you see on the screen, is what you get from the video output).

##### Audio Source Selection

The AN5829 (BTSC decoder) device does the external stereo audio source selection. A maximum of three audio input sources can be selected. AV1 or FRONT is selected by the mechanical switch in the front cinch connector.

The selected external audio source is then fed to the AN5829 AUX1 input (pins 2 and 3). The AV2 is fed directly to AN5829 via AUX2 (pins 23 and 24). Then via I2C, the AN5829 IC source selection can be done.

### 9.2.2 Switching Function for Mono I/O

For the Mono configuration, only one input pin is available for the UOC.

#### Video Source Selection

The video switching is similar to the section above.

#### Audio Source Selection

The audio input (L1\_IN) is connected to pin 35 of the UOC.

## 9.3 Audio

This chassis is targeted for the NAFTA market with Mono, Stereo, or SAP sound system.

For the "basic" Mono and Stereo sets, sound processing includes Volume control and AVL.

For stereo sets, IC AN5829S is the BTSC audio signal decoder and AN5891K is the audio processing IC.

### 9.3.1 Processing

This chassis uses the Intercarrier demodulation concept (one SAW filter for both video and audio). The base band (full bandwidth) BTSC audio signal from the UOC is fed to pin 14 of the stereo decoder. The Pilot detection and SAP detection registers indicate the type of transmitted audio signal such as Mono, Stereo, and/or SAP. Based on this indication, the software controls will help to output the appropriate audio signal at pins 21 and 22. The controls are done by the I2C bus connected to pins 18 and 19.

Internal or External audio (pins 2, 3, 23, and 24) can also be selected by the source selection register. For the selected audio source, the AGC function can be applied. The output is a fixed level output. The volume control function is available via the power amplifier (AN7522/23).

The selected audio output from IC7841 (AN5829) is fed to pins 3 and 22 of IC7821 (AN5891) for audio processing functions, such as Treble, Bass, Volume, Balance, and Surround sound functions. L\_out and R\_out are then available on pins 12 and 15.

IC7821 is also I2C controllable (pins 13 and 14). An AVL function is also available in this IC, and can be used for sets using this IC. In this case, the AVL function of the AN5829 is disabled. Subwoofer output (optional) is available on pin 20.

### 9.3.2 Amplifier

The output is fed to the audio amplifier (IC7901 for stereo sets or IC7902 for mono sets). This is a BTL amplifier (Bridge Tied Load), which is actually a class AB amplifier with four transistors for each channel. The advantage of BTL over the standard Class AB amplifier is that it requires a lower supply voltage to deliver a higher output.

The volume level is controlled at this IC (pin 9) by the "VOLUME" control line coming from the microprocessor. After amplification, the audio signal is sent to the speaker / headphone output connector.

### 9.3.3 AVL (Automatic Volume Limiting)

The "Mono AVL" function operates via the UOC. During channel change and source selection, the AVL bit is to be switched "off" and then can resume to the previous state ("on/off") as shown in the timing diagram below.

The "Stereo AVL" function operates via the AGC control of IC AN5829S. During channel change and source selection, the AGC function is to be switched "off" and then can resume to the previous state ("on/off") as shown in timing diagram below.

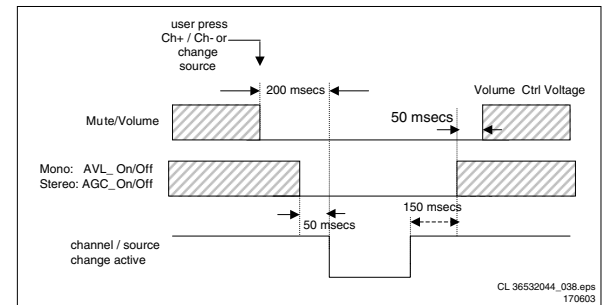

Figure 9-3 AVL timing diagram

### 9.3.4 Mute

The TV set must mute:

- Whenever a "User Mute" is activated.
- Whenever there is a channel change, RF to RF, RF to AV, AV to RF, and AV to AV (if any). In channel change, MUTE must be activated first before any other activity and un-MUTE must be done after every other activity has been completed.
- Whenever there is a loss in the signal.
- During cold or warm start, MUTE must be activated until all initialization processes are finished.
- When the set is going to STANDBY, MUTE must be activated first before any other activities.

#### Note:

1. MUTE mentioned above applies for the audio amplifier mute (= PWM volume control mute).
2. The first condition does not apply for the UOC, IC AN5891K, or IC AN5829S.
3. Above conditions refers to both mono and stereo sets.

## 9.4 Video

For a detailed circuit description of this part, we refer to the L01.2L AA manual (see the beginning of this chapter for the ordering codes). Please note that there can be minor differences in the text (e.g. other item numbers), but the described circuit principle is comparable.

This chassis uses the TDA937x family Ultimate One Chip TV processor (UOC), which is mounted in an SDIP 64 envelope. The various versions of the UOC series combine the function of a video processor together with a microcontroller and US Closed Caption/TXT decoder.

## 9.5 Synchronization

Inside IC7200 (part D) the vertical and horizontal sync pulses are separated. These "H" and "V" signals are synchronized with the incoming CVBS signal. They are then fed to the H- and V-drive circuits and to the OSD/TXT circuit for synchronization of the On Screen Display and Teletext (CC) information.

## 9.6 Deflection

For a detailed circuit description of this part, we refer to the L01.2L AA manual (see the beginning of this chapter for the ordering codes). Please note that there can be minor differences in the text (e.g. other item numbers), but the described circuit principle is comparable.

The L03 range consists of TV sets spanning from 14 to 21 inch using the same chassis architecture. For the chassis architecture, the CRTs used do not need East/West Correction. Therefore the geometry correction needed is horizontal shift, vertical slope, vertical amplitude, vertical S-correction, vertical shift and vertical zoom for geometry corrections (with the appropriate offsets required for NTSC channels on PAL sets).

### 9.7 Power Supply

For a detailed circuit description of this part, we refer to the L01.2L AA manual (see the beginning of this chapter for the ordering codes). Please note that there can be minor differences in the text (e.g. other item numbers), but the described circuit principle is comparable.

#### 9.7.1 Introduction

The supply is a Switching Mode Power Supply (SMPS). The frequency of operation varies with the circuit load. This 'Quasi-Resonant Flyback' behavior has some important benefits compared to a 'hard switching' fixed frequency Flyback converter. The efficiency can be improved up to 90%, which results in lower power consumption. Moreover, the supply runs cooler and safety is enhanced.

The control IC in this power supply is the TEA1506 (L01=TEA1507). Unlike the TEA1507 control IC, the TEA1506 has no internal high voltage start-up source, and therefore needs to be started by means of an external bleeder resistor (R3506 and R3507). The operating voltage for the driver circuit is also taken from the 'hot' side of this transformer.

The switching regulator IC 7520 starts switching the FET 'on' and 'off', to control the current flow through the primary winding of transformer 5520. The energy stored in the primary winding during the 'on' time is delivered to the secondary windings during the 'off' time.

The "MainSupply" line is the reference voltage for the power supply. It is sampled by resistors 3543 and 3544 and fed to the input of the regulator 7540 / 6540. This regulator drives the feedback optocoupler 7515 to set the feedback control voltage on pin 6 of 7520.

The power supply in the set is "on" any time AC power is connected to the set.

#### 9.7.2 Derived Voltages

The voltages supplied by the secondary windings of T5520 are:

- "MainSupply" for the horizontal output.
- "V\_aux/V\_audio" for the audio circuit.
- An optional "DVD\_Supply" for future extensions.

Other voltages are provided by the LOT. It supplies -12 V, the tuner voltage, the filament voltage, and the +160 V source for the video drive. These secondary voltages of the LOT are monitored by the "EHT" lines.

### 9.8 Control

The microprocessor part of the UOC has the complete control and CC/Teletext processing on board. The User menu's and Service Default / Alignment Mode's are generated by the uP. Communication to other ICs is done via the I2C-bus.

#### 9.8.1 I2C-Bus

The main control system, which consists of the microprocessor part of the UOC (7200), is linked to the external devices (Tuner, NVM, Audio ICs, etc) by means of the I2C-bus. An internal I2C-bus is used to control other signal processing functions, like video processing, sound IF, vision IF, synchronization, etc.

#### 9.8.2 User Interface

The chassis uses a remote control with RC5 protocol. The incoming signal is connected to pin 67 of the UOC. The keyboard, connected to UOC pin 8, can also control the set. Button recognition is done via a voltage divider. The front LED (6691) is connected to an output control line of the microprocessor (pin 11). It is activated to provide the user information about whether or not the set is working correctly (e.g., responding to the remote control, normal operation (USA only) or fault condition)

#### 9.8.3 I/O Selection

For the control of the input and output selections, there are three lines:

##### STATUS1

This signal provides information to the microprocessor on whether a video signal is available on the SCART1 AV input and output port (only for Europe). This signal is not connected in LATAM/NAFTA sets.

##### STATUS2

This signal provides information to the microprocessor on whether a video signal is available on the SCART2 AV input and output port (only for Europe). For sets with an SVHS input it provides the additional information if a Y/C or CVBS source is present. The presence of an external Y/C source makes this line 'high' while a CVBS source makes the line 'low'.

##### SEL\_AV1\_AV2

This is the source select control signal from the microprocessor. This control line is under user control or can be activated by the other two control lines.

#### 9.8.4 Power Supply Control

The Power Supply is interfaced with the microcontroller (UOC) to provide the power supply with the control signals required for burst mode operation in standby and to vary the picture width by adjusting V\_BAT.

The microprocessor part is supplied with 3.3 V and 8 V. The 3.3 V is derived from the "V\_aux/V\_audio" voltage via a 3V3 stabilizer (7493). The 8 V is derived from the 33V tuner voltage via TS7491 and TS7496.

Two signals are used to control the power supply: STD\_CON and PW\_ADJ.

##### STD\_CON

This signal is generated by the microprocessor when over-current takes place at the "Main" line. This is done to enable the power supply into standby burst mode, and to enable this mode during a protection.

This is of logic "high" (3.3 V) under normal operation of the TV. When the TV set is in Standby (or fault) condition, this signal is a continuous pulse of 5 ms "low" (0 V) and 5 ms "high".

**Note:** In the L01 chassis this was inverted.

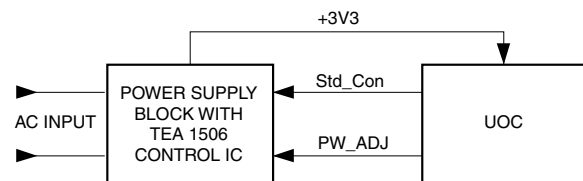

CL 36532044\_039.eps  
180603

Figure 9-4 Block diagram of power supply interface with UOC

**PW\_ADJ**

This signal is generated by the UOC through a PWM port. This PWM port is configured in Push Pull mode to generate a square wave signal of 0 to 100% duty cycle with a default value of 50% duty cycle.

PW\_ADJ will eliminate tolerance and can adjust the picture wide slightly.

**9.8.5 Protection Events**

Several protection events are controlled by the UOC. In case one of these protections is activated, the set will go to "Standby" mode.

**Deflection Protections**

The main protections for deflection are X-ray protection, frame amplifier failure detection, black current loop stability protection, and +8V auxiliary supply protection. For X-ray protection, the X-ray detection bit, XDT, must always be set to "1" (detection mode). High EHT protection must be triggered via software upon detection of the XPR bit switching to "1".

A suitable number of checks are done before putting the set into protection mode in order to prevent false triggering.

For service requirements, the Enable Vertical Guard (RGB blanking), EVG, can be disabled (set to "0") although this is not necessary.

The following bits are monitored:

- SUP (Supply voltage indication)
- XPR (X-ray protection)
- EVG (Enable Vertical Guard)
- NDF (Output Vertical Guard)
- BCF (Black Current Failure)

**I2C Protection**

To check whether all I2C IC's are functioning.

**9.9 Abbreviation List**

2CS	2 Carrier (or Channel) Stereo
ACI	Automatic Channel Installation: algorithm that installs TV sets directly from cable network by means of a predefined TXT page
ADC	Analogue to Digital Converter
AFC	Automatic Frequency Control: control signal used to tune to the correct frequency
AFT	Automatic Fine Tuning
AGC	Automatic Gain Control: algorithm that controls the video input of the feature box
AM	Amplitude Modulation
AP	Asia Pacific
AR	Aspect Ratio: 4 by 3 or 16 by 9
ATS	Automatic Tuning System
AV	External Audio Video
AVL	Automatic Volume Leveler
BCL	Beam Current Limitation
B/G	Monochrome TV system. Sound carrier distance is 5.5 MHz
BTSC	Broadcast Television Standard Committee. Multiplex FM stereo sound system, originating from the USA and used e.g. in LATAM and AP-NTSC countries
CC	Closed Caption
ComPair	Computer aided rePair
CRT	Cathode Ray Tube or picture tube
CSM	Customer Service Mode
CTI	Color Transient Improvement: manipulates steepness of chroma transients
CVBS	Composite Video Blanking and Synchronization
CVI	Component Video Input
DAC	Digital to Analogue Converter
DBX	Dynamic Bass Expander or noise reduction system in BTSC
D/K	Monochrome TV system. Sound carrier distance is 6.5 MHz
DFU	Direction For Use: description for the end user
DNR	Dynamic Noise Reduction
DSP	Digital Signal Processing
DST	Dealer Service Tool: special remote control designed for dealers to enter e.g. service mode
DVD	Digital Versatile Disc
EEPROM	Electrically Erasable and Programmable Read Only Memory
EHT	Extra High Tension
EHT-INFO	Extra High Tension information
EPG	Electronic Programming Guide
EU	Europe
EW	East West, related to horizontal deflection of the set
EXT	External (source), entering the set via SCART or Cinch
FBL	Fast Blanking: DC signal accompanying RGB signals
FILAMENT	Filament of CRT
FM	Field Memory or Frequency Modulation
H	Horizontal sync signal
HP	Headphone
I	Monochrome TV system. Sound carrier distance is 6.0 MHz
I2C	Integrated IC bus
IF	Intermediate Frequency
IIC	Integrated IC bus

ITV	Institutional TV
LATAM	Latin American countries like Brazil, Argentina, etc.
LED	Light Emitting Diode
L/L'	Monochrome TV system. Sound carrier distance is 6.5 MHz. L' is Band I, L is all bands except for Band I
LS	Large Screen or Loudspeaker
M/N	Monochrome TV system. Sound carrier distance is 4.5 MHz
NC	Not Connected
NICAM	Near Instantaneous Compounded Audio Multiplexing. This is a digital sound system, mainly used in Europe.
NTSC	National Television Standard Committee. Color system mainly used in North America and Japan. Color carrier NTSC M/N = 3.579545 MHz, NTSC 4.43 = 4.433619 MHz (this is a VCR norm, it is not transmitted off-air)
NVM	Non Volatile Memory: IC containing TV related data e.g. alignments
OB	Option Bit
OC	Open Circuit
OP	Option Byte
OSD	On Screen Display
PAL	Phase Alternating Line. Color system mainly used in West Europe (color carrier = 4.433619 MHz) and South America (color carrier PAL M = 3.575612 MHz and PAL N = 3.582056 MHz)
PCB	Printed Circuit board
PLL	Phase Locked Loop. Used for e.g. FST tuning systems. The customer can give directly the desired frequency
POR	Power-On Reset
PTP	Picture Tube Panel (or CRT-panel)
RAM	Random Access Memory
RC	Remote Control handset
RGB	Red, Green, and Blue video signals
ROM	Read Only Memory
SDAM	Service Default / Alignment Mode
SAP	Second Audio Program
SC	Sandcastle: pulse derived from sync signals
S/C	Short Circuit
SCL	Serial Clock
SDA	Serial Data
SECAM	SEquence Couleur Avec Memoire. Color system mainly used in France and East Europe. Color carriers = 4.406250 MHz and 4.250000 MHz
SIF	Sound Intermediate Frequency
SS	Small Screen
STBY	Standby
SVHS	Super Video Home System
SW	Software
THD	Total Harmonic Distortion
TXT	Teletext
uP	Microprocessor
UOC	Ultimate One Chip
V	Vertical sync signal
V_BAT	Main supply voltage for the deflection stage (mostly 141 V)
V-chip	Violence Chip
VCR	Video Cassette Recorder
WYSIWYR	What You See Is What You Record: record selection that follows main picture and sound
XTAL	Quartz crystal
YC	Luminance (Y) and Chrominance (C) signal

9.10 IC Data Sheets

This section shows the internal block diagrams and pin layouts of ICs that are drawn as "black boxes" in the electrical diagrams (with the exception of "memory" and "logic" ICs).

9.10.1 Diagram A5, AN5829S (IC7841)

Block Diagram

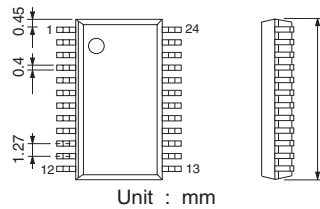
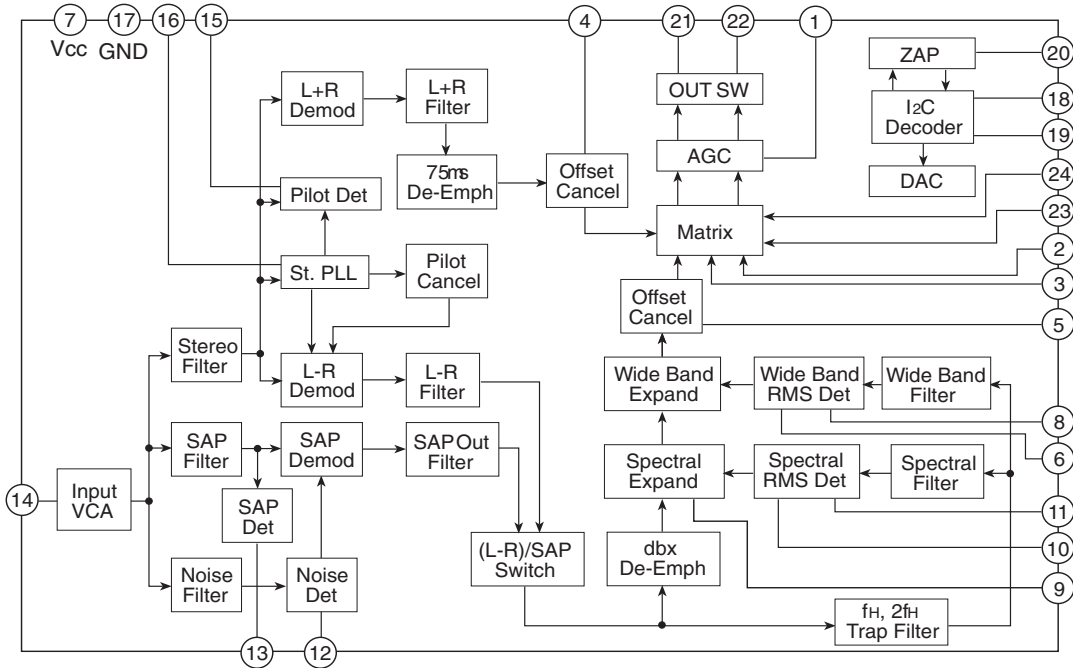

24-Lead PANAFLAT Package (SO-24D)

Test Circuit

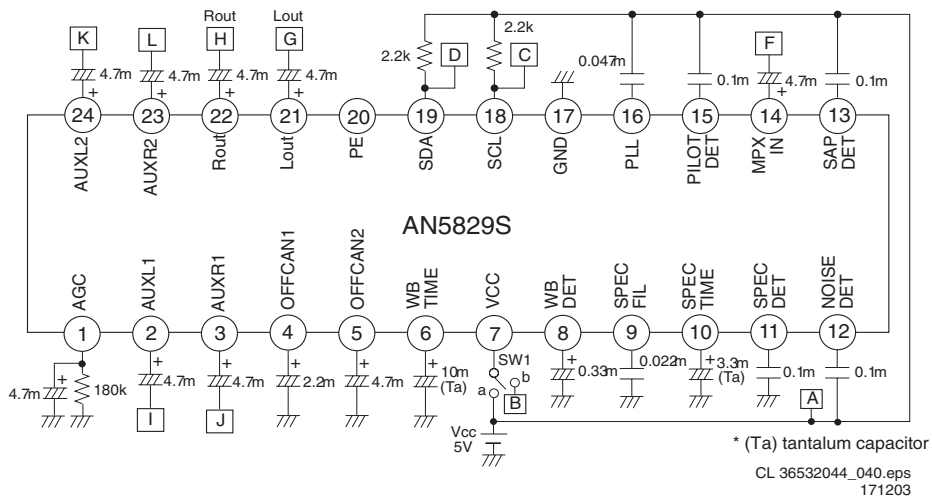

\* (Ta) tantalum capacitor  
CL 36532044\_040.eps  
171203

Figure 9-5 Internal Block Diagram and Pin Configuration

# 10. Spare Parts List

## Sets Used

8670 000 19917	14PT6441/37
8670 000 23674	20MT4405/17
8670 000 19919	20PT5441/37
8670 000 22599	20PT6245/37
8670 000 19922	20PT6341/37
8670 000 20858	20PT6441/37
8670 000 23869	20PT6446/37

## Set Level

### Various

9965 000 34280	CRT assy [B]
9965 000 34281	Mono Carrier assy [A]
9965 000 34282	Side I/O assy [D]
9965 000 34309	Cable 4p/820 340/2X2 Bk
1900▲	9965 000 27250 CRT A51ERF135X82
1900	9965 000 33400 CRT A51KQK99X03
1990	9322 191 16682 A36AKJ15X07

5203	3139 128 76331	Degaussing Coil 15LR Us
5203	3139 128 23841	Degaussing Coil 21LR Us
5203	9965 000 33399	Degaus Coil DC-86113
5994	2422 264 00419	Loudsp. 16Ω 5W fr
5994	2422 264 00479	Loudsp. 16Ω 5W fr
5994	9965 000 27940	Loudsp. YDT513
5995	2422 264 00419	Loudsp. 16Ω 5W fr
5995	2422 264 00479	Loudsp. 16Ω 5W fr
5995	9965 000 27940	Loudsp. YDT513

## Software (See Product Survey)

### 14PT6441/37

7200	9352 749 89112	TDA9377PS/N2/AI/1372
------	----------------	----------------------

### 20MT4405/17

7200	9352 749 89112	TDA9377PS/N2/AI/1372
------	----------------	----------------------

### 20PT5441/37

7200	9352 749 89112	TDA9377PS/N2/AI/1372
------	----------------	----------------------

### 20PT6245/37

7200	9965 000 34290	TDA9377PS/N3/A/1907
------	----------------	---------------------

### 20PT6341/37

7200	9352 778 64112	TDA9377PS/N3/A/1629
------	----------------	---------------------

### 20PT6441/37

7200	9352 749 89112	TDA9377PS/N2/AI/1372
------	----------------	----------------------

### 20PT6446/37

7200	9965 000 34290	TDA9377PS/N3/A/1907
------	----------------	---------------------

## Mono Carrier [A]

### Various

9965 000 34287	Rear I/O assy
9965 000 34289	Control assy
0022	9965 000 34299 Connector313913101801
0025	9965 000 34300 Connector313911038591
0141	4822 492 70788 Fix IC
0157	9965 000 27973 Connector31391312391
0163	3139 110 38950 Cable 6p/400/6p Bk
0177	9965 000 27972 Connector310431103011
0186	9965 000 27262 Cable 5p/680/5p Bk
0186	9965 000 30256 Cable 05p/680/05p Bk
0211	2422 025 16268 Connector 2p m
0211	4822 265 20723 Connector 2p
0211	9965 000 27334 CONNECTOR VH3P2A

0211	9965 000 34293	CONNECTOR VH3P2A
0212	2422 025 16268	Connector 2p m
0212	4822 265 20723	Connector 2p
0212	9965 000 27274	PIN BASE *3 VH-3A
0214	2422 025 06353	Connector 5p m
0217	4822 267 10735	Connector 3p
0217	9965 000 30069	PIN BASE
0221	4822 267 10966	Connector 2p
0221	9965 000 30066	PIN BASE
0222	2422 025 10646	Connector 2p m
0222	9965 000 32105	Connector VH-2A 2p
0223	2422 026 05236	Socket Cinch 9p f
0223	9965 000 27246	AV Socket 242202605236
0223	9965 000 34226	AV Socket 242202605236
0225	2422 026 04926	Soc. Mini-DIN 4p f
0232	4822 267 31014	Sckt headphone
0239	2422 025 16382	Connector 3p m
0246	2422 025 15848	Connector 5p m
0246	9965 000 27221	Pin base EH-6A
0250	9965 000 27369	RCA Socket
0253	9965 000 17468	Socket Ear Phone
0254	9965 000 27221	Pin base EH-6A
0255	9965 000 27221	Pin base EH-6A
1000▲	2422 542 00029	Tuner V U PLL F
1000	2422 542 90141	Tuner V+U PLL F
1000	9965 000 23791	TUNER TEDH9-251A
1000	9965 000 33085	TUNER TEQH2X001A
1000	9965 000 35352	TUNER ENV56K06G3
1001	2422 549 44327	Filter 43MHz
1001	9965 000 23794	SAW M1971M
1121	4822 267 10735	Connector 3p
1121	9965 000 30069	PIN BASE
1124	2422 025 12482	Connector 6p m
1124	9965 000 31198	CONNECTOR
1124	9965 000 34310	CON. BMV 6P
1184	4822 267 10735	Connector 3p
1184	9965 000 30069	PIN BASE
1185	2422 025 12482	Connector 6p m
1185	9965 000 31198	CONNECTOR
1201	4822 242 81978	TPSA,5MB-TF21
1201	9965 000 23325	Crystall 4.5MB
1302	9965 000 23828	SOCKET CRT
1302	9965 000 34283	CRT SOCKET
1500	2422 090 01101	Soc Fuse 1P Female
1500	9965 000 23784	Fuse holder
1501	2422 090 01101	Soc Fuse 1P Female
1501	9965 000 23784	Fuse holder
1504	2422 086 10914	Fuse 4A 250V
1504	9965 000 17570	FUSE T4E 250V
1504	9965 000 34294	FUSE T4E 250V
1515	2422 132 07467	Relay 1p 12V 5A LKS1AF
1515	9965 000 27333	RELAY 1KS1AF
1600	4822 276 13775	Switch 1p 0.1A 12V
1600	9965 000 17540	Switch
1601	4822 276 13775	Switch 1p 0.1A 12V
1601	9965 000 17540	Switch
1602	4822 276 13775	Switch 1p 0.1A 12V
1602	9965 000 17540	Switch
1603	4822 276 13775	Switch 1p 0.1A 12V
1603	9965 000 17540	Switch
1606	4822 276 13775	Switch 1p 0.1A 12V
1606	9965 000 17540	Switch
1621	2422 543 01268	Xtal 12MHz 20p
1621	9965 000 23770	Crystal 12MHZ
1622	4822 265 41114	Connector 9p
1681	4822 267 10734	Connector 5p
1681	9965 000 27221	Pin base EH-6A

—|—

2001	2238 586 59812	100nF 20% 50V 0603
2001	9965 000 27286	100nF 10% 50V 0603
2002	4822 124 41643	100µF 20% 16V
2002	9965 000 14069	100µF 20% 16V
2003	4822 122 33761	22pF 5% 50V
2003	9965 000 14011	22pF 5% 50V
2004	4822 122 33761	22pF 5% 50V
2004	9965 000 14011	22pF 5% 50V
2005	3198 024 44730	47nF 50V 0603
2005	9965 000 27374	47nF+80/-20% 50V
2006	4822 124 80195	470µF 20% 10V
2006	9965 000 17508	470µF 20% 10V
2007	4822 124 40248	10µF 20% 63V
2007	9965 000 14075	10µF 20% 50V
2101	3198 017 44740	470nF 10V 0603
2101	9965 000 27228	470nF 80/-20% 16V
2102	4822 122 33761	22pF 5% 50V

2102	9965 000 14011	22pF 5% 50V
2103	4822 126 14241	330pF 0603 50V
2103	9965 000 27243	330pF -10% 50V
2104	4822 126 14241	330pF 0603 50V
2104	9965 000 27243	330pF -10% 50V
2105	4822 124 21732	10UF 20% 25V
2105	9965 000 27241	10µF -/20% 25V
2106	4822 124 21732	10UF 20% 25V
2106	9965 000 27241	10µF -/20% 25V
2111	4822 122 33761	22pF 5% 50V
2111	9965 000 14011	22pF 5% 50V
2112	4822 122 33761	22pF 5% 50V
2112	9965 000 14011	22pF 5% 50V
2113	4822 122 33761	22pF 5% 50V
2113	9965 000 14011	22pF 5% 50V
2122	4822 126 14241	330pF 0603 50V
2122	9965 000 27243	330pF -10% 50V
2123	3198 017 41050	1µF 10V 0603
2123	9965 000 24287	1µF 80/-20% 16V
2124	4822 126 14241	330pF 0603 50V
2124	9965 000 27243	330pF -10% 50V
2125	3198 017 41050	1µF 10V 0603
2125	9965 000 24287	1µF 80/-20% 16V
2132	3198 017 41050	1µF 10V 0603
2132	9965 000 24287	1µF 80/-20% 16V
2134	3198 017 41050	1µF 10V 0603
2134	9965 000 24287	1µF 80/-20% 16V
2135	4822 122 33761	22pF 5% 50V
2135	9965 000 14011	22pF 5% 50V
2136	4822 122 33761	22pF 5% 50V
2136	9965 000 14011	22pF 5% 50V
2161	4822 126 14491	2.2µF 10V 0805
2161	9965 000 23838	2.2µF 20% 16V
2163	4822 126 14491	2.2µF 10V 0805
2163	9965 000 23838	2.2µF 20% 16V
2171	9965 000 27365	330pF 10% 50V
2172	9965 000 27365	330pF 10% 50V
2175	9965 000 27364	22pF 5% 50V
2176	9965 000 17876	470pF 10% 50V
2177	9965 000 14075	10µF 20% 50V
2178	9965 000 17876	470pF 10% 50V
2179	9965 000 14075	10µF 20% 50V
2181	4822 122 33761	22pF 5% 50V
2181	9965 000 14011	22pF 5% 50V
2182	4822 126 14241	330pF 0603 50V
2182	9965 000 27243	330pF -10% 50V
2183	4822 126 14241	330pF 0603 50V
2183	9965 000 27243	330pF -10% 50V
2201	4822 126 13193	4.7nF 10% 63V
2202	9965 000 27305	4700pF 10% 50V 0603
2202	4822 126 14241	330pF 0603 50V
2202	9965 000 20346	330pF 5% 50V 0603
2203	3198 017 44740	470nF 10V 0603
2203	9965 000 27228	470nF 80/-20% 16V
2205	4822 124 12255	10µF 5% 50V
2205	9965 000 27660	10µF 10% 25V
2205	9965 000 33082	10µF 10% 25V
2206	2020 552 96664	33pF 50V 0603
2206	9965 000 32085	33pF 5% 50V
2207	2238 586 59812	100nF 20% 50V 0603
2207	9965 000 27286	100nF 10% 50V 0603
2208	2238 586 59812	100nF 20% 50V 0603
2208	9965 000 27286	100nF 10% 50V 0603
2209	2238 586 59812	100nF 20% 50V 0603
2209	9965 000 27286	100nF 10% 50V 0603
2210	4822 126 13879	220nF +80-20% 16V
2210	9965 000 27900	0.22µF 20% 50V 0603
2211	3198 016 31020	1nF 25V 0603
2211	9965 000 27244	1nF 5% 25V
2212	4822 126 13879	220nF +80-20% 16V
2212	9965 000 27900	0.22µF 20% 50V 0603
2231	2238 916 15641	22nF 10% 25V 0603
2231	9965 000 27245	22nF 10% 25V
2232	2238 916 15641	22nF 10% 25V 0603
2232	9965 000 27245	22nF 10% 25V
2233	2238 916 15641	22nF 10% 25V 0603
2233	9965 000 27245	22nF 10% 25V
2300	9965 000 20346	330pF 5% 50V 0603
2301	9965 000 20351	390pF 5% 50V 0603
2302	9965 000 20351	390pF 5% 50V 0603
2303	9965 000 22813	10nF 10% 2kV
2304	9965 000 32125	47nF 5% 250V
2405	4822 124 11936	47µF 20% 160V
2405	9965 000 17512	47µF 20% 160V
2406	2022 333 00258	270nF 5% 250V
2406	2022 333 00261	360nF 5% 250V
2406	9965 000 26036	0.27µF 5% 250V
2406	9965 000 28532	0.22µF 5% 250V
2406	9965 000 34288	240nF 5% 250V

2408	2022 333 00278	680nF 5% 250V	2497	5322 126 11578	1nF 10% 50V 0603	2831	5322 124 40641	10µF 20% 100V
2408	9965 000 24840	0.68µF 5% 250V	2497	9965 000 20356	1000pF 10% 50V 0603	2831	9965 000 32069	10µF 20% 100V
2420	2020 552 00164	100nF 10% 50V 0603	2500	2222 338 22474	470nF 20% 275V	2832	5322 124 40641	10µF 20% 100V
2420	2238 586 59812	100nF 20% 50V 0603	2500	9965 000 27329	0.47µF 20% 250V	2832	9965 000 32069	10µF 20% 100V
2420	9965 000 27286	100nF 10% 50V 0603	2501	4822 126 12793	2.2nF 10% 2kV	2833	5322 124 40641	10µF 20% 100V
2421	2020 552 00164	100nF 10% 50V 0603	2501	9965 000 24631	2200pF 10% 1kV	2833	9965 000 32069	10µF 20% 100V
2421	2238 586 59812	100nF 20% 50V 0603	2502	4822 126 12793	2.2nF 10% 2kV	2835	5322 126 11583	10nF 10% 50V 0603
2421	9965 000 27286	100nF 10% 50V 0603	2502	9965 000 24631	2200pF 10% 1kV	2835	9965 000 27300	0.01µF 10% 50V
2423	2022 333 00256	15nF 5% 1.6kV	2503	2020 024 90585	220µF 20% 200V	2836	2238 586 59812	100nF 20% 50V 0603
2423	2022 333 00267	8.2nF 5% 1.6kV	2503	9965 000 15785	220µF 20% 200V	2836	9965 000 27286	100nF 10% 50V 0603
2423	5322 121 44333	12nF 5% 1.6kV	2515	2020 554 90199	1.5nF 250V	2837	3198 017 44740	470nF 10V 0603
2423	9965 000 23824	15nF 5% 1.6kV	2515	9965 000 32078	1.5nF 20% 250V	2837	9965 000 27228	470nF 80/-20% 16V
2423	9965 000 27285	8.2nF 5% 1.6kV	2520	5322 126 11583	4.7nF 10% 50V 0603	2838	5322 124 40641	10µF 20% 100V
2424	4822 126 13449	1nF 10% 2kV	2520	9965 000 27300	0.01µF 10% 50V	2838	9965 000 32069	10µF 20% 100V
2424	4822 126 13865	390pF 10% 2kV	2521	4822 124 81151	22µF 50V	2841	2020 552 96305	4.7µF 20-80% 10V
2424	4822 126 14138	680pF 10% 2kV	2521	9965 000 27331	22µF 50V	2841	9965 000 23767	4.7µF +80/-20% 16V
2424	9965 000 15590	1000pF 10% 2kV	2522	5322 126 11578	1nF 10% 50V 0603	2844	4822 124 22652	2.2µF 20% 50V
2424	9965 000 27284	390pF 10% 2kV	2522	9965 000 20356	1000pF 10% 50V 0603	2844	9965 000 28015	22µF 20% 50V
2426	3198 016 31020	1nF 25V 0603	2523	4822 126 13862	1.5nF 10% 2kV	2845	4822 124 12032	4.7µF 20% 50V
2426	9965 000 27244	1nF 5% 25V	2523	9965 000 27992	1500pF 10%	2845	9965 000 14039	4.7µF 20% 50V
2427	2238 586 59812	100nF 20% 50V 0603	2525	4822 126 13909	680pF 10% 50V 0603	2846	5322 124 40641	10µF 20% 100V
2427	9965 000 24622	100nF +80/20% 25V	2525	9965 000 27331	680pF 10% 50V	2846	9965 000 32069	10µF 20% 100V
2428	4822 124 80231	47UF20% 16V	2527	4822 126 14225	56pF 5% 50V 0603	2847	4822 124 23052	100UF20% 16V
2428	9965 000 23748	47µF 20% 16V	2527	9965 000 27330	56pF 5% 50V 0603	2847	9965 000 14588	100µF 20% 16V
2429	2020 552 00258	220nF 50V 0603	2528	4822 124 81151	22µF 50V	2848	2238 786 19856	330nF 20% 160V 0603
2429	4822 126 13879	220nF +80-20% 16V	2540	3198 017 31530	15nF 20% 50V 0603	2848	9965 000 27307	0.33µF 80% /20 50V
2429	9965 000 27900	0.22µF 20% 50V 0603	2540	9965 000 27301	0.015µF 10% 50V	2849	2238 916 15641	22nF 10% 25V 0603
2441	4822 121 51305	15nF 10% 50V	2541	4822 126 13193	4.7nF 10% 63V	2849	9965 000 27245	22nF 10% 25V
2441	5322 121 42489	33nF 5% 250V	2541	9965 000 27305	4700pF 10% 50V 0603	2850	2020 009 90103	3.3µF 20% 50V
2441	9965 000 14080	33nF 5% 50V	2542	3198 017 44740	470nF 10V 0603	2850	9965 000 27299	3.3µF 20% 50V
2441	9965 000 17520	15nF 63V +/-5%	2542	9965 000 27228	470nF 80/-20% 16V	2851	2238 586 59812	100nF 20% 50V 0603
2444	4822 124 80791	470µF 20% 16V	2543	5322 126 11578	1nF 10% 50V 0603	2851	9965 000 27286	100nF 10% 50V 0603
2444	9965 000 14599	470µF 20% 16V	2543	9965 000 20356	1000pF 10% 50V 0603	2852	2238 586 59812	100nF 20% 50V 0603
2446	2022 031 00139	470nF 20% 16V	2546	5322 122 32818	2.2nF 10% 100V	2852	9965 000 27286	100nF 10% 50V 0603
2446	4822 124 80791	470µF 20% 16V	2560	9965 000 27328	2200pF 10% 50V	2855	3198 017 41050	1µF 10V 0603
2446	9965 000 32071	470µF 20% 16V	2560	9965 000 30713	2.2nF 10% 50V	2855	9965 000 24287	1µF 80/-20% 16V
2447	2020 012 93596	22µF 20% 250V	2561	4822 123 14025	2200µF 20% 16V	2856	3198 017 41050	1µF 10V 0603
2447	4822 124 11565	10µF 20% 250V	2561	4822 124 40196	220µF 20% 16V	2856	9965 000 24287	1µF 80/-20% 16V
2447	9965 000 14921	10µF 20% 250V	2562	4822 126 13449	1nF 10% 2kV	2857	3198 017 34730	47nF 16V 0603
2447	9965 000 24628	22µF 250V +/-20%	2562	9965 000 33083	1000pF10% 2kV	2857	9965 000 27306	47nF 20% 50V 0603
2452	2238 586 59812	100nF 20% 50V 0603	2564	4822 124 42336	47µF 20% 160V	2858	3198 017 41050	1µF 10V 0603
2452	2238 916 15641	22nF 10% 25V 0603	2564	9965 000 17512	47µF 20% 160V	2858	9965 000 24287	1µF 80/-20% 16V
2452	9965 000 27245	22nF 10% 25V	2580	4822 124 40433	47µF 20% 25V	2859	3198 017 41050	1µF 10V 0603
2452	9965 000 27920	100nF +/-10% 25V	2580	9965 000 15182	47µF 20% 25V	2859	9965 000 24287	1µF 80/-20% 16V
2455	4822 124 11947	10µF 20% 16V	2585	5322 126 11578	1nF 10% 50V 0603	2860	2238 586 59812	100nF 20% 50V 0603
2455	9965 000 27860	10µF +/-20% 16V	2585	9965 000 20356	1000pF 10% 50V 0603	2860	9965 000 27286	100nF 10% 50V 0603
2457	4822 122 31177	470pF 10% 500V	2602	2020 552 96664	33pF 50V 0603	2861	4822 126 13883	220pF 5% 50V
2457	9965 000 17562	470pF 10% 500V	2602	9965 000 32085	33pF 5% 50V	2861	9965 000 20349	220pF 5% 50V 0603
2460	4822 121 41754	82nF 10% 100V	2603	2020 552 96664	33pF 50V 0603	2862	4822 126 13883	220pF 5% 50V
2460	5322 121 42662	68nF 5% 250V	2603	9965 000 32085	33pF 5% 50V	2862	9965 000 20349	220pF 5% 50V 0603
2460	9965 000 27261	82nF 20% 250V	2604	4822 124 11947	10µF 20% 16V	2863	4822 126 13883	220pF 5% 50V
2461	3198 016 31020	1nF 25V 0603	2604	9965 000 27860	10µF +/-20% 16V	2863	9965 000 20349	220pF 5% 50V 0603
2461	9965 000 27244	1nF 5% 25V	2605	2238 586 59812	100nF 20% 50V 0603	2901	5322 126 11583	10nF 10% 50V 0603
2462	3198 016 31020	1nF 25V 0603	2605	9965 000 27286	100nF 10% 50V 0603	2901	9965 000 27300	0.01µF 10% 50V
2462	9965 000 27244	1nF 5% 25V	2607	2238 586 59812	100nF 20% 50V 0603	2903	4822 124 21913	1µF 20% 63V
2463	4822 124 41751	47µF 20% 50V	2607	9965 000 27286	100nF 10% 50V 0603	2903	9965 000 14037	1µF 20% 50V
2463	9965 000 14076	47µF 20% 50V	2608	3198 017 41050	1µF 10V 0603	2904	3198 017 34730	47nF 16V 0603
2464	2238 606 11545	470pF 5 100V 0603	2608	9965 000 24287	1µF 80/-20% 16V	2904	3198 017 44740	470nF 10V 0603
2464	4822 126 13881	470pF 5% 50V	2609	2238 586 59812	100nF 20% 50V 0603	2904	9965 000 27228	470nF 80/-20% 16V
2464	9965 000 14012	470pF 5% 50V 0603	2609	9965 000 27286	100nF 10% 50V 0603	2906	3198 017 34730	47nF 16V 0603
2465	2022 031 00127	10µF 20% 160V	2612	4822 124 40196	220µF 20% 16V	2906	3198 017 44740	470nF 10V 0603
2465	9965 000 27904	10µF 20% 160V	2612	9965 000 14070	220µF 20% 16V	2906	9965 000 27228	470nF 80/-20% 16V
2470	2022 318 00126	15nF 10% 63V	2615	2238 586 55622	820pnF 10% 50V 0603	2908	4822 124 22726	4.7µF 20% 35V
2470	5322 121 42975	15NF5% 250V	2615	9965 000 27342	820pF 10% 50V	2908	9965 000 14039	4.7µF 20% 50V
2470	9965 000 32068	0.033µF 5% 100V	2616	4822 124 11947	10µF 20% 16V	2909	4822 124 40248	10µF 20% 63V
2473	4822 126 13881	470pF 5% 50V	2616	9965 000 27860	10µF +/-20% 16V	2909	9965 000 14075	10µF 20% 50V
2473	9965 000 14012	470pF 5% 50V 0603	2641	3198 016 31020	1nF 25V 0603	2950	4822 126 14247	1.5nF 50V 0603
2481	2020 552 94427	100pF 5% 50V	2641	9965 000 27244	1nF 5% 25V	2950	9965 000 14010	1500pF 10% 50V
2481	9965 000 13965	100pF 5% 50V	2642	3198 016 31020	1nF 25V 0603	2951	3198 016 38210	820pF 25V 0603
2482	3198 017 41050	1µF 50V 0603	2642	9965 000 27244	1nF 5% 25V	2951	9965 000 27898	820pF 5% 50V 0603
2482	9965 000 24287	1µF 80/-20% 16V	2643	4822 126 13883	220pF 5% 50V	2952	3198 016 38210	820pF 25V 0603
2483	2020 552 96305	4.7µF 20-80% 10V	2643	9965 000 20349	220pF 5% 50V 0603	2952	9965 000 27898	820pF 5% 50V 0603
2483	9965 000 23767	4.7µF +80/-20% 16V	2691	4822 124 41584	100µF 20% 10V	2981	4822 124 40248	10µF 20% 63V
2484	2238 586 59812	100nF 20% 50V 0603	2691	9965 000 15805	100µF 20% 10V	2981	9965 000 14075	10µF 20% 50V
2484	9965 000 27286	100nF 10% 50V 0603	2821	4822 124 41584	100µF 20% 10V	2982	4822 126 13881	470pF 5% 50V
2485	3198 017 41050	1µF 10V 0603	2821	9965 000 15805	100µF 20% 10V	2982	9965 000 27906	470pF 10% 50V
2485	9965 000 24287	1µF 80/-20% 16V	2822	4822 126 14549	33nF 16V 0603	2983	4822 124 40248	10µF 20% 63V
2486	4822 126 13193	4.7nF 10% 63V	2822	9965 000 27303	0.033µF 10% 50V	2983	9965 000 14075	10µF 20% 50V
2486	9965 000 27305	4700pF 10% 50V 0603	2823	5322 124 40641	10µF 20% 100V	2984	4822 126 13881	470pF 5% 50V
2487	4822 126 14238	2.2nF 50V 0603	2823	9965 000 32069	10µF 20% 100V	2984	9965 000 27906	470pF 10% 50V
2487	9965 000 27341	2200pF 10% 50V 0603	2824	5322 124 40641	10µF 20% 100V			
2488	5322 121 42386	100nF 5% 63V	2824	9965 000 32069	10µF 20% 100V			
2488	9965 000 27340	CBB11-50V-104J	2825	2238 786 55644	39nF 10% 16V X7R 0603			
2489	5322 126 11578	1nF 10% 50V 0603	2825	9965 000 27304	0.039µF 10% 50V 0603			
2489	9965 000 20356	1000pF 10% 50V 0603	2826	3198 017 31530				

3101	4822 051 30689	68Ω 5% 0.063W 0603	3210	9965 000 14049	100Ω 5% 0.16W	3455	9965 000 32045	2.2kΩ 1/10W 0603
3101	9965 000 27239	68Ω 5% 1/10W 0603	3231	4822 051 30561	560Ω 5% 0.062W	3459	4822 116 52245	150kΩ 5% 0.5W
3102	4822 051 30102	1kΩ 5% 0.062W	3231	9965 000 32060	560Ω 1/10W 0603	3459	9965 000 23744	150kΩ 5% 0.17W
3102	9965 000 32038	1kΩ 1/10W 0603	3232	4822 050 11002	1kΩ 1% 0.4W	3460	4822 117 12925	47kΩ 1% 0.063W 0603
3103	4822 051 30151	150Ω 5% 0.062W	3232	9965 000 12519	1k 5% 0.16W	3460	4822 117 13632	100kΩ 1% 0603 0.62W
3103	9965 000 32041	150Ω 1/10W 0603	3300	9965 000 23309	18kΩ 5% 3W	3460	9965 000 27226	100kΩ 1/10W 0603
3104	4822 117 12891	220kΩ 1%	3301	9965 000 32119	1.5kΩ 20% 1/2W	3460	9965 000 32058	47kΩ 1/10W 0603
3104	9965 000 32047	220kΩ 1/10W 0603	3303	9965 000 32050	330Ω 1/10W 0603	3461	4822 051 30222	2.2kΩ 5% 0.062W
3105	4822 051 30151	150Ω 5% 0.062W	3304	9965 000 23309	18kΩ 5% 3W	3461	9965 000 32045	2.2kΩ 1/10W 0603
3105	9965 000 32041	150Ω 1/10W 0603	3305	9965 000 32119	1.5kΩ 20% 1/2W	3462	4822 051 30105	1MΩ 5% 0.062W
3106	4822 117 12891	220kΩ 1%	3307	9965 000 32050	330Ω 1/10W 0603	3462	9965 000 27259	Fuse 1MΩ 5% 1/10W
3106	9965 000 32047	220kΩ 1/10W 0603	3308	9965 000 23309	18kΩ 5% 3W	3463	4822 051 30222	2.2kΩ 5% 0.062W
3111	4822 051 30759	75Ω 5% 0.062W	3309	9965 000 32119	1.5kΩ 20% 1/2W	3463	9965 000 32045	2.2kΩ 1/10W 0603
3111	9965 000 27240	75Ω 1/10W 0603	3311	9965 000 32053	390Ω 1/10W 0603	3464	4822 116 52256	2.2kΩ 5% 0.5W
3112	4822 051 30101	100Ω 5% 0.062W	3313	9965 000 27252	Fuse 68Ω 5% 1/3W	3464	9965 000 12515	2.2k 5% 0.16W
3112	9965 000 32037	100Ω 1/10W 0603	3318	9965 000 27251	Fuse 220Ω 5% 1/3W	3465	4822 051 30102	1kΩ 5% 0.062W
3113	4822 051 30759	75Ω 5% 0.062W	3319	9965 000 32119	1.5kΩ 20% 1/2W	3465	9965 000 32038	1kΩ 1/10W 0603
3113	9965 000 27240	75Ω 1/10W 0603	3402	4822 117 11824	2k2 5%	3466	4822 051 30102	1kΩ 5% 0.062W
3114	4822 051 30101	100Ω 5% 0.062W	3402	9965 000 33080	2.2kΩ 5% 3W	3466	9965 000 32038	1kΩ 1/10W 0603
3114	9965 000 32037	100Ω 1/10W 0603	3403	4822 052 10471	470Ω 5% 0,33W	3468	4822 116 52219	330Ω 5% 0.5W
3115	4822 051 30759	75Ω 5% 0.062W	3403	4822 117 11824	2K2 5%	3468	9965 000 12592	330Ω 5% 0.16W
3115	9965 000 27240	75Ω 1/10W 0603	3403	9965 000 25710	RES 3W 470 OHM +/- 5%	3470	4822 052 10108	1Ω 5% 0.33W
3116	4822 051 30101	100Ω 5% 0.062W	3403	9965 000 33080	2.2kΩ 5% 3W	3470	9965 000 27258	Fuse 1Ω 5% 1/3W
3116	9965 000 32037	100Ω 1/10W 0603	3410	4822 116 52297	68kΩ 5% 0.5W	3471	4822 116 83872	220Ω 5% 0.5W
3122	4822 051 30008	Jumper 0603	3410	9965 000 31684	Resistor fixed carbon	3471	9965 000 12549	220Ω 55 0.16W
3122	9965 000 27224	0Ω 5% 1/10W 0603	3422	4822 053 20334	330kΩ 5% 0.25W	3472	4822 116 83872	220Ω 5% 0.5W
3123	4822 051 30008	Jumper 0603	3422	4822 053 21334	330kΩ 5% 0.5W	3472	9965 000 12549	220Ω 55 0.16W
3123	4822 051 30151	150Ω 5% 0.062W	3422	9965 000 23746	330kΩ 0.25W	3473	2312 915 12708	2.7Ω
3123	9965 000 27224	0Ω 5% 1/10W 0603	3422	9965 000 28464	330kΩ 1/2W	3473	4822 050 23308	3.3Ω 1% 0.6W
3123	9965 000 32041	150Ω 1/10W 0603	3424	4822 053 11479	47R00 5% 2W	3473	9965 000 23826	3.3Ω 1% 0.5W
3124	4822 117 12925	47kΩ 1% 0.063W 0603	3424	9965 000 27278	47Ω 5% 2W	3473	9965 000 23827	2.7Ω 1% 0.5W
3124	9965 000 32058	47kΩ 1/10W 0603	3424	9965 000 34634	100Ω 5% 2W	3474	4822 050 23308	3.3Ω 1% 0.6W
3125	4822 051 30008	Jumper 0603	3425	4822 050 22201	220Ω 1% 0.6W	3474	9965 000 23826	3.3Ω 1% 0.5W
3125	4822 051 30151	150Ω 5% 0.062W	3425	9965 000 15675	220Ω 5% 1W	3475	4822 050 21003	10kΩ 1% 0.6W
3125	9965 000 27224	0Ω 5% 1/10W 0603	3426	4822 116 52195	47Ω 5% 0.5W	3475	9965 000 14050	10k 5% 0.16W
3125	9965 000 32041	150Ω 1/10W 0603	3426	9965 000 12593	47Ω 5% 0.16W	3476	4822 111 31041	8.2k 5% 0.16W
3126	4822 117 12925	47kΩ 1% 0.063W 0603	3428	4822 116 52199	68Ω 5% 0.5W	3476	4822 116 52303	8.2kΩ 5% 0.5W
3126	9965 000 32058	47kΩ 1/10W 0603	3428	9965 000 13958	68Ω 5% 0.17W	3478	4822 116 80176	1Ω 5% 0.5W
3135	4822 051 30759	75Ω 5% 0.062W	3430	4822 051 30102	1kΩ 5% 0.062W	3478	4822 116 82805	1Ω 5% 0.17W
3135	9965 000 27240	75Ω 1/10W 0603	3430	9965 000 32038	1kΩ 1/10W 0603	3479	4822 052 10189	18R00 5% 0,33W
3136	4822 116 52175	100Ω 5% 0.5W	3432	4822 051 30471	47Ω 5% 0.062W	3479	9965 000 27223	Fuse 18Ω -5% 1/3W
3136	9965 000 14049	100Ω 5% 0.16W	3432	9965 000 32056	470kΩ 5% 1/10W	3480	4822 051 30393	39kΩ 5% 0.062W
3137	4822 051 30759	75Ω 5% 0.062W	3439	4822 050 21504	150kΩ 1% 0.6W	3480	9965 000 32055	39kΩ 5% 1/10W
3137	9965 000 27240	75Ω 1/10W 0603	3439	9965 000 23745	150kΩ 1% 0.5W	3481	4822 051 30183	18kΩ 5% 0.062W
3138	4822 051 30101	100Ω 5% 0.062W	3440	2322 704 63303	33kΩ 1% 0603	3481	9965 000 27335	18kΩ 5% 1/10W
3138	9965 000 32037	100Ω 1/10W 0603	3440	9965 000 27281	33kΩ 1% 1/10W 0603	3481	4822 116 83866	1MΩ 5% 0.5W
3142	9965 000 14049	100Ω 5% 0.16W	3441	4822 051 30103	10kΩ 5% 0.062W	3483	9965 000 12626	1.0mΩ 5% 0.17W
3143	4822 111 31225	75Ω 5% 0.16W	3441	4822 051 30273	27kΩ 5% 0.062W	3485	4822 051 30102	1kΩ 5% 0.062W
3144	9965 000 12485	150Ω 5% 0.16W	3441	4822 117 12925	47kΩ 1% 0.063W 0603	3485	9965 000 32038	1kΩ 1/10W 0603
3145	4822 111 31023	47k 5% 0.16W	3441	9965 000 32049	27kΩ 5% 1/10W	3486	4822 051 30102	1kΩ 5% 0.062W
3146	9965 000 12485	150Ω 5% 0.16W	3441	9965 000 32058	47kΩ 1/10W 0603	3486	9965 000 32038	1kΩ 1/10W 0603
3147	4822 111 31023	47k 5% 0.16W	3442	4822 116 52234	100kΩ 5% 0.5W	3487	4822 051 30333	33kΩ 5% 0.062W
3148	9965 000 15050	270Ω 5% 0.16W	3442	4822 116 52245	150kΩ 5% 0.5W	3487	9965 000 27236	33kΩ 1/10W 0603
3149	9965 000 15050	270Ω 5% 0.16W	3442	9965 000 17939	100k 5% 0.25W	3488	4822 116 52243	1.5kΩ 5% 0.5W
3161	4822 051 30333	33kΩ 5% 0.062W	3443	4822 052 10188	1.8Ω 5% 0.33W	3488	9965 000 15044	1.5k 5% 0.16W
3161	9965 000 27236	33kΩ 1/10W 0603	3443	4822 052 10338	3.3Ω 5% 0.33W	3489	4822 051 30103	10kΩ 5% 0.062W
3162	4822 051 30103	10kΩ 5% 0.062W	3443	4822 052 10398	3.9Ω 5% 0.33W	3489	9965 000 32039	10kΩ 1/10W 0603
3162	9965 000 32039	10kΩ 1/10W 0603	3443	9965 000 27277	Fuse 3.3Ω 5% 1/3W	3490	4822 116 52269	3.3kΩ 5% 0.5W
3163	4822 051 30102	1kΩ 5% 0.062W	3443	9965 000 33406	Fuse 1.8Ω 5% 1/3W	3490	9965 000 31774	3.3kΩ 5% 0.16W
3163	9965 000 32038	1kΩ 1/10W 0603	3444	4822 052 10188	1.8Ω 5% 0.33W	3491	4822 111 31023	47k 5% 0.16W
3164	4822 050 13303	33kΩ 1% 0,4W	3444	4822 052 10338	3.3Ω 5% 0.33W	3491	4822 116 83884	47kΩ 5% 0.5W
3164	4822 050 23303	33kΩ 1% 0.6W	3444	4822 052 10478	4.7Ω 5% 0.33W	3492	4822 051 30183	18kΩ 5% 0.062W
3181	4822 116 52201	75Ω 5% 0.5W	3444	9965 000 27277	Fuse 3.3Ω 5% 1/3W	3492	9965 000 27335	18kΩ 5% 1/10W
3182	4822 116 52175	100Ω 5% 0.5W	3444	9965 000 33406	Fuse 1.8Ω 5% 1/3W	3493	4822 052 10189	18R00 5% 0,33W
3182	9965 000 14049	100Ω 5% 0.16W	3445	4822 052 10108	1Ω 5% 0.33W	3493	9965 000 27223	Fuse 18Ω -5% 1/3W
3183	4822 116 83868	150Ω 5% 0.5W	3445	9965 000 27258	Fuse 1Ω 5% 1/3W	3495	4822 116 52191	33Ω 5% 0.5W
3183	9965 000 12485	150Ω 5% 0.16W	3446	4822 052 10108	1Ω 5% 0.33W	3495	9965 000 27873	33kΩ 5% 1/6W
3184	4822 117 12925	47kΩ 1% 0.063W 0603	3446	9965 000 27258	Fuse 1Ω 5% 1/3W	3497	4822 116 83881	390Ω 5% 0.5W
3184	9965 000 32058	47kΩ 1/10W 0603	3447	4822 051 30154	150kΩ 5% 0.062W	3497	9965 000 14056	390Ω 5% 0.17W
3185	4822 116 83868	150Ω 5% 0.5W	3447	4822 051 30333	33kΩ 5% 0.062W	3498	4822 050 21003	10kΩ 1% 0.6W
3185	9965 000 12485	150Ω 5% 0.16W	3447	4822 117 12925	47kΩ 1% 0.063W 0603	3498	9965 000 14050	10k 5% 0.16W
3186	4822 117 12925	47kΩ 1% 0.063W 0603	3447	9965 000 27322	150kΩ 5% 1/10W 0603	3499	4822 051 30273	27kΩ 5% 0.062W
3186	9965 000 32058	47kΩ 1/10W 0603	3447	9965 000 32058	47kΩ 1/10W 0603	3499	9965 000 32049	27kΩ 5% 1/10W
3201	4822 051 30392	3.9Ω 5% 0.063W 0603	3448	4822 052 10108	1Ω 5% 0.33W	3500	4822 053 21335	3.3MΩ 5% 0.5W
3201	9965 000 32054	3.9kΩ 5% 1/10W	3448	9965 000 27258	Fuse 1Ω 5% 1/3W	3500	9965 000 32034	3.3MΩ 1/2W
3202	4822 051 30101	100Ω 5% 0.062W	3449	4822 116 52264	27kΩ 5% 0.5W	3501	4822 053 21335	3.3MΩ 5% 0.5W
3202	9965 000 32037	100Ω 1/10W 0603	3449	9965 000 27858	27kΩ 5% 1/6W	3501	9965 000 32034	3.3MΩ 1/2W
3203	4822 051 30102	1kΩ 5% 0.062W	3450	4822 116 52264	27kΩ 5% 0.5W	3502	2122 612 00055	4.7Ω 3W
3203	9965 000 32038	1kΩ 1/10W 0603	3450	9965 000 27858	27kΩ 5% 1/6W	3502	9965 000 15782	NTC 4.7Ω 18%
3204	2322 702 60829	82Ω 5% 0603	3451	4822 051 30681	680Ω 5% 0.062W	3502	9965 000 27041	NTC 4.7Ω -20%
3204	4822 117 13501	82Ω 5% 0.62W 0603	3451	4822 117 12903	1.8kΩ 1% 0.063W 0603	3503	2120 661 00026	PTC 10Ω 30% 120V
3204	9965 000 27338	82Ω 5% 1/10W	3451	5322 117 12905	8.2kΩ 1% 0.063W 0603	3503	2122 663 00019	PTC 3Ω 144V 20%
3204	9965 000 28503	82Ω 5% 1/10W	3451	9965 000 27279	1.8Ω 5% 1/10W	3503	9965 000 27326	PTC 3Ω 144V 20%
3205	4822 051 30271	270Ω 5% 0.062W	3451	9965 000 32062	8.2kΩ 5% 1/10W	3505	4822 116 21224	VDR 1mA/387V
3205	9965 000 27336	270Ω 5% 1/10W	3452	4822 116 83866	1MΩ 5% 0.5W	3506	4822 053 20334	330kΩ 5% 0.25W
3206	48							

3520	4822 117 11817	1.2kΩ 1% 0.0625W	3686	9965 000 33088	390Ω 1% 1/10W	4853	9965 000 27224	0Ω 5% 1/10W 0603
3520	9965 000 27320	1.2kΩ 1/10W 0603	3687	2322 704 62202	2.2kΩ 1% 0603	4922	4822 051 30008	Jumper 0603
3522	4822 051 30334	330kΩ 5% 0.062W	3687	9965 000 27293	2.2kΩ 1% 1/10W 0603	4922	9965 000 27224	0Ω 5% 1/10W 0603
3522	9965 000 32052	330kΩ 5% 1/10W	3688	2322 704 62001	200Ω 1% 0603	4981	4822 051 30008	Jumper 0603
3523	4822 052 10101	100Ω 5% 0.33W	3688	9965 000 27292	200Ω 1% 1/10W 0603	4981	9965 000 27224	0Ω 5% 1/10W 0603
3523	9965 000 27318	Fuse 100Ω 5% 1/3W	3691	4822 051 30331	330Ω 5% 0.062W	4983	4822 051 30008	Jumper 0603
3524	4822 051 30008	Jumper 0603	3691	9965 000 12592	330Ω 5% 0.16W	4983	9965 000 27224	0Ω 5% 1/10W 0603
3524	9965 000 27224	0Ω 5% 1/10W 0603	3691	9965 000 32050	330Ω 1/10W 0603			
3525	4822 051 30102	1kΩ 5% 0.062W	3693	4822 116 83872	220Ω 5% 0.5W			
3525	9965 000 32038	1kΩ 1/10W 0603	3693	9965 000 12549	220Ω 5% 0.16W			
3526	3198 012 11570	0.15Ω 5% 1W	3694	4822 051 30472	4.7Ω 5% 0.062W			
3526	9965 000 23785	0.15Ω 5% 1W	3694	9965 000 15057	4.7k 5% 0.16W			
3527	4822 052 10101	100Ω 5% 0.33W	3694	9965 000 32057	4.7kΩ 1/10W 0603			
3527	4822 052 10222	2.2kΩ 5% 0.33W	3822	4822 117 12891	220kΩ 1%			
3527	9965 000 27318	Fuse 100Ω 5% 1/3W	3822	9965 000 32047	220kΩ 1/10W 0603	5001	3198 018 18270	0.82μH 10%
3527	9965 000 27319	Fuse 2.2kΩ 5% 1/3W	3822	4822 051 30008	Jumper 0603	5001	9965 000 27372	0.82μH 10%
3528	4822 051 30103	10kΩ 5% 0.062W	3822	9965 000 27224	0Ω 5% 1/10W 0603	5002	4822 157 51216	5.6μH 10%
3528	9965 000 32039	10kΩ 1/10W 0603	3827	4822 116 52175	100Ω 5% 0.5W	5002	9965 000 27371	5.6μH 10%
3541	4822 051 30471	47Ω 5% 0.062W	3827	9965 000 14049	100Ω 5% 0.16W	5201	4822 157 11835	4.7mH 10%
3541	9965 000 32056	470kΩ 5% 1/10W	3827	4822 116 52175	100Ω 5% 0.5W	5201	9965 000 23768	4.7mH 10%
3542	4822 116 52243	1.5kΩ 5% 0.5W	3827	9965 000 14049	100Ω 5% 0.16W	5401	9965 000 24842	33μH
3542	9965 000 15044	1.5k 5% 0.16W	3828	4822 116 52175	100Ω 5% 0.5W	5402▲	2422 535 91021	33μH C910-02
3543	4822 050 28203	82kΩ 1% 0.6W	3828	9965 000 14049	100Ω 5% 0.16W	5402	2422 536 00425	Linearity coil 21"
3543	9965 000 23773	82kΩ 1% 0.5W	3841	2322 702 60184	180kΩ 5% 0603	5402▲	2422 536 01158	82μH
3544	3198 039 68020	6.8kΩ 1%	3841	9965 000 27297	180kΩ 5% 1/10W 0603	5402	4822 157 11712	82μH
3544	9965 000 23772	6.8kΩ 1% 0.5W	3842	4822 116 52175	100Ω 5% 0.5W	5402	9965 000 27273	82μH
3545	4822 051 30222	2.2kΩ 5% 0.062W	3842	9965 000 14049	100Ω 5% 0.16W	5421▲	2422 531 00099	Trafo JDT1022
3545	9965 000 32045	2.2kΩ 1/10W 0603	3842	4822 050 11002	1kΩ 1% 0.4W	5421	2422 531 02589	PSD10-204B
3546	4822 116 83961	6.8kΩ 5%	3843	9965 000 12519	1k 5% 0.16W	5421	9965 000 33081	Trafo JDT102
3546	9965 000 12520	6.8kΩ 1/6W 5% CF	3843	4822 116 52269	3.3kΩ 5% 0.5W	5441	2422 531 02614	LOT JF0501-19272R
3547	4822 051 30223	22kΩ 5% 0.062W	3843	9965 000 14049	100Ω 5% 0.16W	5441	2422 531 02615	LOT JF0501-19255R
3547	4822 051 30334	330kΩ 5% 0.062W	3901	4822 050 31774	3.3kΩ 5% 0.16W	5441	2422 531 02616	LOT JF0501-19276R
3547	9965 000 32046	22kΩ 5% 1/10W	3902	9965 000 31774	3.3kΩ 5% 0.16W	5441	9965 000 33407	FBT JF0501-19276R
3547	9965 000 32052	330kΩ 5% 1/10W	3902	4822 116 52269	3.3kΩ 5% 0.5W	5482	4822 157 11706	10μH 5%
3548	4822 051 30153	15kΩ 5% 0.062W	3903	4822 116 52269	3.3kΩ 5% 0.5W	5482	9965 000 14082	10μH 10%
3548	9965 000 32043	15kΩ 1/10W 0603	3903	9965 000 31774	3.3kΩ 5% 0.16W	5502	2422 549 44284	Filter 5MHz C914-0
3549	4822 116 83872	220Ω 5% 0.5W	3904	4822 051 30103	10kΩ 1/10W 0603	5502	4822 157 11163	DMF-2422H
3549	9965 000 12549	220Ω 5% 0.16W	3905	4822 116 52269	3.3kΩ 5% 0.5W	5502	9965 000 17573	Line Filter C914-01
3580	4822 117 12925	47kΩ 1% 0.063W 0603	3905	9965 000 31774	3.3kΩ 5% 0.16W	5502	9965 000 27332	Line Filter
3580	9965 000 32058	47kΩ 1/10W 0603	3906	4822 051 30103	10kΩ 5% 0.062W	5509	4822 526 10704	Bead 50 Ω at 100MHz
3581	4822 051 30008	Jumper 0603	3906	9965 000 32039	10kΩ 1/10W 0603	5509	9965 000 17576	BF-I35045W
3581	4822 051 30569	56Ω 5% 0.062W	3907	5322 117 13056	8.2kΩ 1% 0.063W 0603	5515	4822 157 11411	Bead 80Ω at 100MHz
3581	9965 000 27224	0Ω 5% 1/10W 0603	3907	9965 000 32062	8.2kΩ 5% 1/10W	5515	9965 000 23760	FERR BEAD LB3.5X1X9
3581	9965 000 27929	56Ω 1/10W 0603	3911	4822 117 13632	100kΩ 1% 0603 0.62W	5520▲	2422 531 00098	Trafo BCK-35-0259
3601	4822 051 30222	2.2kΩ 5% 0.062W	3911	9965 000 27226	100kΩ 1/10W 0603	5520	2422 531 02479	Trafo SS28032-01A
3601	9965 000 32045	2.2kΩ 1/10W 0603	3981	4822 116 83876	270Ω 5% 0.5W	5520▲	2422 531 02619	PSS35-205B Y
3602	4822 051 30222	2.2kΩ 5% 0.062W	3981	9965 000 15050	270Ω 5% 0.16W	5520▲	9965 000 33084	Trafo BCK-35-0259
3602	9965 000 32045	2.2kΩ 1/10W 0603	3982	4822 116 83876	270Ω 5% 0.5W	5520▲	9965 000 33408	Trafo SS28032-01A
3603	4822 116 52256	2.2kΩ 5% 0.5W	3982	9965 000 15050	270Ω 5% 0.16W	5520	9965 000 34292	Trafo BCK-35-0259
3603	9965 000 12515	2.2k 5% 0.16W	4122	4822 051 30008	Jumper 0603	5521	4822 526 10704	Bead 50 Ω at 100MHz
3604	4822 116 52175	100Ω 5% 0.5W	4122	4822 051 30008	Jumper 0603	5521	9965 000 17576	BF-I35045W
3604	9965 000 14049	100Ω 5% 0.16W	4126	4822 051 30008	Jumper 0603	5562	4822 157 11411	Bead 80Ω at 100MHz
3605	4822 116 52175	100Ω 5% 0.5W	4126	9965 000 27224	0Ω 5% 1/10W 0603	5562	9965 000 23760	FERR BEAD LB3.5X1X9
3605	9965 000 14049	100Ω 5% 0.16W	4127	4822 051 30008	Jumper 0603	5563	4822 157 52392	27μH
3606	4822 050 21003	10kΩ 1% 0.6W	4127	9965 000 27224	0Ω 5% 1/10W 0603	5563	9965 000 23780	27μH SPT0406A-270K
3606	9965 000 14050	10k 5% 0.16W	4129	4822 051 30008	Jumper 0603	5601	4822 157 11867	5.6μH 5%
3607	4822 051 30101	100Ω 5% 0.062W	4129	9965 000 27224	0Ω 5% 1/10W 0603	5601	9965 000 23769	5.6μH 10%
3607	9965 000 32037	100Ω 1/10W 0603	4132	4822 051 30008	Jumper 0603	5602	4822 157 11867	5.6μH 5%
3608	4822 051 30154	150kΩ 5% 0.062W	4132	9965 000 27224	0Ω 5% 1/10W 0603	5602	9965 000 23769	5.6μH 10%
3608	9965 000 27322	150kΩ 5% 1/10W 0603	4133	4822 051 30008	Jumper 0603	5603	4822 157 11867	5.6μH 5%
3618	4822 050 11002	1kΩ 1% 0.4W	4133	9965 000 27224	0Ω 5% 1/10W 0603	5603	9965 000 23769	5.6μH 10%
3618	9965 000 20378	1kΩ 1% 1/6W	4151	4822 051 30008	Jumper 0603	5821	4822 157 11706	10μH 5%
3619	4822 116 52175	100Ω 5% 0.5W	4151	9965 000 27224	0Ω 5% 1/10W 0603	5821	9965 000 14082	10μH 10%
3619	9965 000 14049	100Ω 5% 0.16W	4152	4822 051 30008	Jumper 0603	5841	4822 157 11706	10μH 5%
3620	4822 116 52175	100Ω 5% 0.5W	4152	9965 000 27224	0Ω 5% 1/10W 0603	5841	9965 000 14082	10μH 10%
3620	9965 000 14049	100Ω 5% 0.16W	4300	9965 000 27224	0Ω 5% 1/10W 0603			
3621	4822 116 52175	100Ω 5% 0.5W	4301	9965 000 27224	0Ω 5% 1/10W 0603			
3621	9965 000 14049	100Ω 5% 0.16W	4302	9965 000 27224	0Ω 5% 1/10W 0603			
3624	4822 050 21003	10kΩ 1% 0.6W	4303	9965 000 27224	0Ω 5% 1/10W 0603			
3624	9965 000 14050	10k 5% 0.16W	4306	9965 000 27224	0Ω 5% 1/10W 0603			
3633	4822 050 11002	1kΩ 1% 0.4W	4405	4822 051 30008	Jumper 0603			
3633	9965 000 12519	1k 5% 0.16W	4405	9965 000 27224	0Ω 5% 1/10W 0603			
3634	4822 050 11002	1kΩ 1% 0.4W	4491	4822 051 30008	Jumper 0603			
3634	9965 000 12519	1k 5% 0.16W	4491	9965 000 27224	0Ω 5% 1/10W 0603			
3641	4822 116 52175	100Ω 5% 0.5W	4571	4822 051 30008	Jumper 0603			
3641	9965 000 14049	100Ω 5% 0.16W	4571	9965 000 27224	0Ω 5% 1/10W 0603			
3642	4822 051 30101	100Ω 5% 0.062W	4610	4822 051 30008	Jumper 0603			
3642	9965 000 32037	100Ω 1/10W 0603	4610	9965 000 27224	0Ω 5% 1/10W 0603			
3643	4822 051 30101	100Ω 5% 0.062W	4661	4822 051 20008	Jumper 0805			
3643	9965 000 32037	100Ω 1/10W 0603	4661	9965 000 17478	0Ω 5% 0.1W			
3644	4822 051 30472	4.7Ω 5% 0.062W	4692	4822 051 30008	Jumper 0603			
3644	9965 000 32057	4.7kΩ 1/10W 0603	4692	9965 000 27224	0Ω 5% 1/10W 0603			
3646	4822 051 30105	1MΩ 5% 0.062W	4694	4822 051 30008	Jumper 0603			
3646	9965 000 27259	Fuse 1MΩ 5% 1/10W	4694	9965 000 27224	0Ω 5% 1/10W 0603			
3681	5322 117 13057	820Ω 1% 0.063W 0603	4698	4822 051 30008	Jumper 0603			
3681	9965 000 27296	820Ω 1% 1/10W 0603	4698	9965 000 27224	0Ω 5% 1/10W 0603			
3682	2322 704 61201	120Ω 1% 0.063W 0603	4821	4822 051 30008	Jumper 0603			
3682	9965 000 33087	47Ω 1% 1/10W	4821	9965 000 27224	0Ω 5% 1/10W 0603			
3683	4822 116 52206	120Ω 5% 0.5W	4822	4822 051 30008	Jumper 0603			
3683	9965 000 17494	120Ω 5% 1/6W	4822	9965 000 27224	0Ω 5% 1/10W 0603			
3685	2322 704 62001	200Ω 1% 0603	4847	4822 051 30008	Jumper 0603			
3685	9965 000 17494	120Ω 5% 1/6W	4847	9965 000 27224	0Ω 5% 1/10W 0603			
3685	9965 000 27292	200Ω 1% 1/10W 0603	4852	4822 051 30008	Jumper 0603			
3686	2322 704 64301	430Ω 1%	4852	9965 000 27224	0Ω 5% 1/10W 0603			
			4853	4822 051 30008	Jumper 0603			

6452	4822 130 11397	BAS316
6452	9340 255 30135	BAS216
6453	4822 130 34142	BZX79-B33
6453	9965 000 15716	33V 5% 0.5W
6460	4822 130 11397	BAS316
6460	9340 255 30135	BAS216
6461	4822 130 31607	RGP10D
6461	9965 000 13880	DIODE FR104-B OR
6462	4822 130 31607	RGP10D
6462	9965 000 13880	DIODE FR104-B OR
6463	4822 130 31607	RGP10D
6463	9965 000 13880	DIODE FR104-B OR
6464	4822 130 11397	BAS316
6464	9340 255 30135	BAS216
6466	4822 130 80931	EGP20D
6466	9322 164 42682	EGP20DL-5100
6481	4822 130 11397	BAS316
6481	9340 255 30135	BAS216
6491	5322 130 34331	BAV70
6491	9965 000 30118	BAV70
6492	3198 020 55680	BZX384-C5V6
6500	4822 130 31083	BYW55
6500	9965 000 15164	RL255
6501	4822 130 31083	BYW55
6501	9965 000 15164	RL255
6502	4822 130 31083	BYW55
6502	9965 000 15164	RL255
6503	4822 130 31083	BYW55
6503	9965 000 15164	RL255
6520	4822 130 41601	BYV95A
6520	9335 187 60673	RGP15D
6522	4822 130 41601	BYV95A
6522	9335 187 60673	RGP15D
6540	4822 130 34167	BZX79-B6V2
6541	4822 130 30862	BZX79-B9V1
6560	9322 161 76682	SB340L-7024
6560	9965 000 27866	DIODE SR360 3A/60V
6561	9322 192 67682	BYW76-PK1
6562	9322 192 67682	BYW76-PK1
6580	4822 130 30621	1N4148
6624	4822 130 11397	BAS316
6624	9340 255 30135	BAS216
6625	4822 130 34382	BZX79-B8V2
6625	4822 130 61219	BZX79-B10
6626	4822 130 11397	BAS316
6626	9340 255 30135	BAS216
6627	4822 130 11397	BAS316
6627	9340 255 30135	BAS216
6628	4822 130 11397	BAS316
6628	9340 255 30135	BAS216
6681	4822 130 11397	BAS316
6681	9340 255 30135	BAS216
6691	9322 185 69682	LED 10234WHCR
6692	9322 127 54667	TSOP1836UH1
6692	9322 206 78667	TSOP34836UH1B
6908	9322 102 64685	UDZ2.7B
6908	9965 000 23738	BZX384-C2V7
6909	4822 130 30621	1N4148



7101	5322 130 60159	BC846B
7161	5322 130 60159	BC846B
7162	5322 130 60159	BC846B
7200		SW see page 1 of partslist
7201	5322 130 60159	BC846B
7202	5322 130 60159	BC846B
7308	4822 130 41782	BF422
7310	4822 130 41782	BF422
7312	4822 130 41782	BF422
7313	4822 130 41782	BF422
7314	9965 000 27851	BF423 (PNP)
7315	4822 130 41782	BF422
7316	9965 000 27851	BF423 (PNP)
7317	4822 130 41782	BF422
7318	9965 000 27851	BF423 (PNP)
7421	9322 183 16687	BUL312FP
7421	9340 563 21127	BUT11APX-1200
7421	9965 000 32016	BUTHAPX-1200
7422	4822 130 42804	BC817-25
7423	5322 130 60845	BC807-25
7423	9965 000 27861	BC807-25 215
7440	4822 130 41646	BF423
7440	9965 000 27851	BF423 (PNP)
7451	4822 130 60373	BC856B
7461	4822 130 60373	BC856B
7462	4822 130 60373	BC856B
7463	4822 130 44461	BC546B
7464	4822 130 40823	BD139
7464	9965 000 27222	2SD669A-C
7465	4822 130 40824	BD140
7465	9965 000 27257	2SB649A-C
7466	5322 130 60159	BC846B

7491	5322 130 60159	BC846B
7493	4822 209 16978	LF33CV
7494	4822 130 40981	BC337-25
7496	4822 130 40823	BD139
7496	9965 000 27222	2SD669A-C
7515	8238 274 02070	TCET1103G
7520	9352 720 43118	TEA1506T/N1
7521	9322 194 20687	STP5NK50ZFP
7521	9322 196 57687	STP10NK80ZFP
7523	4822 130 60373	BC856B
7540	4822 130 40959	BC547B
7541	4822 130 11155	PDTC114ET
7580	5322 130 60159	BC846B
7601	3198 010 44010	PDTA114ET
7641	9322 147 25682	M24C16-WBN6
7641	9965 000 27875	EEPROM M24C16
7821	9322 191 49682	AN5891K
7841	9322 189 97668	IC SM AN5829S (MATJ) R
7901	9322 181 41682	AN7522N

### CRT Panel [B]

#### Various

1300	4822 265 41114	Connector 9p
1301	2422 500 80077	Sct. CRT V 9P
1302	2422 500 80076	Socket CRT 9p f
1302	9965 000 34283	CRT SOCKET
1302	9965 000 34599	SOCKET CRT

—||—

2300	4822 126 14241	330pF 0603 50V
2300	9965 000 20346	330pF 5% 50V 0603
2301	4822 126 14315	390pF 5% 50V 0603
2301	9965 000 20351	390pF 5% 50V 0603
2302	4822 126 14315	390pF 5% 50V 0603
2302	9965 000 20351	390pF 5% 50V 0603
2303	4822 126 13449	1nF 10% 2kV
2303	9965 000 22813	10nF 10% 2kV
2304	4822 121 70386	47nF 10% 250V
2304	9965 000 32125	47nF 5% 250V

—WW—

3300	4822 053 12183	18K00 5% 3W
3300	9965 000 23309	18kΩ 5% 3W
3301	3198 013 01520	1.5kΩ 20% 0.5W
3301	9965 000 32119	1.5kΩ 20% 1/2W
3303	4822 051 30331	330Ω 5% 0.062W
3303	9965 000 32050	330Ω 1/10W 0603
3304	4822 053 12183	18K00 5% 3W
3304	9965 000 23309	18kΩ 5% 3W
3305	3198 013 01520	1.5kΩ 20% 0.5W
3305	9965 000 32119	1.5kΩ 20% 1/2W
3307	4822 051 30331	330Ω 5% 0.062W
3307	9965 000 32050	330Ω 1/10W 0603
3308	4822 053 12183	18K00 5% 3W
3308	9965 000 23309	18kΩ 5% 3W
3309	3198 013 01520	1.5kΩ 20% 0.5W
3309	9965 000 32119	1.5kΩ 20% 1/2W
3311	4822 051 30331	330Ω 5% 0.062W
3311	4822 051 30391	390Ω 5% 0.062W
3311	9965 000 32053	390Ω 1/10W 0603
3313	4822 052 10689	68R00 5% 0.33W
3313	9965 000 27252	Fuse 68Ω 5% 1/3W
3318	4822 052 10221	220Ω 5% 0.33W
3318	9965 000 27251	Fuse 220Ω 5% 1/3W
3319	3198 013 01520	1.5kΩ 20% 0.5W
3319	9965 000 32119	1.5kΩ 20% 1/2W
4300	4822 051 30008	Jumper 0603
4300	9965 000 27224	0Ω 5% 1/10W 0603
4301	4822 051 30008	Jumper 0603
4301	9965 000 27224	0Ω 5% 1/10W 0603
4302	4822 051 30008	Jumper 0603
4302	9965 000 27224	0Ω 5% 1/10W 0603
4303	4822 051 30008	Jumper 0603
4303	9965 000 27224	0Ω 5% 1/10W 0603
4304	4822 051 30008	Jumper 0603
4305	4822 051 30008	Jumper 0603
4306	4822 051 30008	Jumper 0603
4306	9965 000 27224	0Ω 5% 1/10W 0603

—D—

6301	4822 130 11397	BAS316
6301	9340 255 30135	BAS216
6307	4822 130 11397	BAS316
6307	9340 255 30135	BAS216

6318	4822 130 10837	UDZS8.2B
6318	9965 000 32235	BZX384-C8V2



7308	4822 130 41782	BF422
7310	4822 130 41782	BF422
7312	4822 130 41782	BF422
7313	4822 130 41782	BF422
7314	4822 130 41646	BF423
7314	9965 000 27851	BF423 (PNP)
7315	4822 130 41782	BF422
7316	4822 130 41646	BF423
7316	9965 000 27851	BF423 (PNP)
7317	4822 130 41782	BF422
7318	4822 130 41646	BF423
7318	9965 000 27851	BF423 (PNP)

### Side I/O Panel [D]

#### Various

0025	3139 131 01771	Cable 3p 1000mm
0186	3139 110 38861	Cable 5p/680/5p
0250	2422 026 04742	Socket Cinch 3p f
0250	9965 000 27369	RCA Socket
0252	2422 025 12482	Connector 6p m
0252	9965 000 31198	CONNECTOR
0252	9965 000 34310	CON. BMV 6P
0253	4822 267 31014	Sckt headphone
0253	9965 000 17468	Socket Ear Phone
0254	4822 267 10734	Connector 5p
0255	4822 267 10565	Connector 4p
0318	9965 000 33272	PUSH BOTTON
1810	4822 267 10735	Connector 3p

—||—

2171	9965 000 27365	330pF 10% 50V
2172	9965 000 27365	330pF 10% 50V
2175	9965 000 27364	22pF 5% 50V
2176	9965 000 17876	470pF 10% 50V
2177	9965 000 14075	10μF 20% 50V
2178	9965 000 17876	470pF 10% 50V
2179	9965 000 14075	10μF 20% 50V

—WW—

3142	9965 000 14049	100Ω 5% 0.16W
3143	4822 111 31025	75Ω 5% 0.16W
3144	9965 000 12485	150Ω 5% 0.16W
3145	4822 111 31023	47k 5% 0.16W
3146	9965 000 12485	150Ω 5% 0.16W
3147	4822 111 31023	47k 5% 0.16W
3148	9965 000 15050	270Ω 5% 0.16W
3149	9965 000 15050	270Ω 5% 0.16W

—D—

6171	4822 130 34278	BZX79-B6V8
------	----------------	------------

### Control Board [E]

#### Various

0158	9965 000 28003	Cable 3p/1000/03p
1010	9965 000 28004	Connector 3p m
1011	9965 000 17540	Switch
1012	9965 000 17540	Switch
1013	9965 000 17540	Switch
1014	9965 000 17540	Switch

—WW—

3011	9965 000 27292	200Ω 1% 1/10W 0603
3012	9965 000 33088	390Ω 1% 1/10W
3012	9965 000 35162	390Ω 1% 1/10W
3013	9965 000 27293	2.2kΩ 1% 1/10W 0603
3013	9965 000 35163	2.2kΩ 1% 1/10W 0805
3014	9965 000 27292	200Ω 1% 1/10W 0603
3015	9965 000 27296	820Ω 1% 1/10W 0603
3015	9965 000 35164	820Ω 1% 1/10W
3016	9965 000 33087	47Ω 1% 1/10W

# 11. Revision List

**Manual xxxx xxx xxxx.0**

- First release.

**Manual xxxx xxx xxxx.1**

- information for 27V model added.

**Manual xxxx xxx xxxx.2**

- Table of contents updated with links.
- Some small text changes made.

**Manual xxxx xxx xxxx.3**

- New models added.
- Option Byte table updated.
- Block Diagrams and Panel Layouts updated.
- Some small text changes made.
- Spare parts list added.

