

Service Manual

Color Television

Main Manual (DX2P)



Panasonic

Models	Chassis
CT-32HX40B	AP346
CT-32HX40CB	AP346
CT-36HX40B	AP347
CT-36HX40CB	AP347

This Service manual is issued as a service guide for the models of the **DX2P** family listed above. Included in this manual are a set of schematics, block diagrams, functional descriptions, alignment procedures, disassembly procedures, and a complete parts list.

WARNING! This Service Manual is designed for experienced repair technicians only and is not designed for use by the general public. It does not contain warnings or cautions to advise non-technical individuals of potential dangers in attempting to service a product. **Products powered by electricity should be serviced or repaired only by experienced professional technicians.** Any attempt to service or repair the product or products dealt with in this Service Manual by anyone else could result in serious injury or death."

The service technician is required to read and follow the "Safety Precautions" and "Important Safety Notice" in this Main Manual.

Panasonic®

Copyright 2000 by Matsushita Electric Corporation of America. All rights reserved. Unauthorized copying and distribution is a violation of law.

Important Safety Notice

Special components are used in this television set which are important for safety. These parts are identified on the schematic diagram by the symbol  and printed in **BOLD TYPE** on the replacement part list. It is essential that these critical parts are replaced with the manufacturer's specified replacement part to prevent X-ray radiation, shock, fire or other hazards. Do not modify the original design without the manufacturer's permission.

Safety Precautions

General Guidelines

An **Isolation Transformer** should always be used during the servicing of a receiver whose chassis is not isolated from AC power line. Use a transformer of adequate power rating as this protects the technician from accidents resulting in personal injury from electrical shocks. It will also protect the Receiver from being damaged by accidental shorting that may occur during servicing.

When servicing, observe the original lead dress, especially in the high voltage circuit. Replace all damaged parts (also parts that show signs of overheating.)

Always Replace Protective Devices, such as fishpaper, isolation resistors and capacitors, and shields after servicing the Receiver. Use only manufacturer's recommended rating for fuses, circuits breakers, etc.

High potentials are present when this Receiver is operating. Operation of the Receiver without the rear cover introduces danger for electrical shock. Servicing should not be performed by anyone who is not thoroughly familiar with the necessary precautions when servicing high-voltage equipment.

Extreme care should be practiced when **Handling the Picture Tube**. Rough handling may cause it to implode due to atmospheric pressure. (14.7 lbs per sq. in.). Do not nick or scratch the glass or subject it to any undue pressure. When handling, use safety goggles and heavy gloves for protection. **Discharge the picture tube** by shorting the anode to chassis ground (not to the cabinet or to other mounting hardware). When discharging connect cold ground (i.e. dag ground lead) to the anode with a well insulated wire or use a grounding probe.

Avoid prolonged exposure at close range to unshielded areas of the picture tube to prevent exposure to X-ray radiation.

The **Test Picture Tube** used for servicing the chassis at the bench should incorporate safety glass and magnetic shielding. The safety glass provide shielding for the tube viewing area against X-ray radiation as well as implosion. The magnetic shield limits the X-ray radiation around the bell of the picture tube in addition to the restricting magnetic effects. When using a picture tube test jig for service, ensure that the jig is capable of handling **50.0kV** without causing X-ray radiation.

Before returning a serviced receiver to the owner, the service technician must thoroughly test the unit to ensure that is completely safe to operate. **Do not use a line isolation transformer when testing.**

Leakage Current Cold Check

Unplug the AC cord and connect a jumper between the two plug prongs.

Measure the resistance between the jumpered AC plug and expose metallic parts such as screwheads, antenna terminals, control shafts, etc. If the exposed

metallic part has a return path to the chassis, the reading should be between 240k Ω and 5.2M Ω . If the exposed metallic part does not have a return path to the chassis, the reading should be infinite.

Leakage Current Hot Check (Fig. 1)

Plug the AC cord directly into the AC outlet. Do not use an isolation transformer during the check.

Connect a 1.5k Ω 10 watt resistor in parallel with a 0.15 μ F capacitor between an exposed metallic part and ground. Use earth ground, for example a water pipe.

Using a DVM with a 1000 ohms/volt sensitivity or higher, measure the AC potential across the resistor.

Repeat the procedure and measure the voltage present with all other exposed metallic parts.

Verify that any potential does not exceed 0.75 volt RMS. A leakage current tester (such a Simpson Model 229, Sencore Model PR57 or equivalent) may be used in the above procedure, in which case any current measure must not exceed 1/2 milliamp. If any measurement is out of the specified limits, there is a possibility of a shock hazard and the Receiver must be repaired and rechecked before it is returned to the customer.

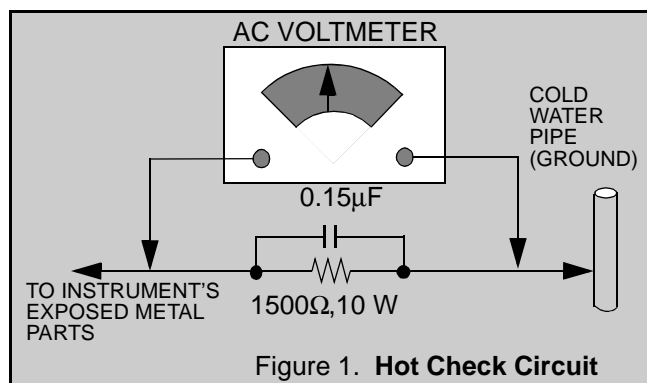

X-ray Radiation

WARNING: The potential source of X-ray radiation in the TV set is in the High Voltage section and the picture tube.

Note: It is important to use an accurate, calibrated high voltage meter.

Set the **brightness, picture, sharpness** and **color** controls to Minimum.

Measure the High Voltage. The high voltage should be **31.0kV \pm 1.0kV**. If the upper limit is out of tolerance, immediate service and correction is required to insure safe operation and to prevent the possibility of premature component failure.

Horizontal Oscillator Disable Circuit Test

This test must be performed as a final check before the Receiver is returned to the customer. See **Horizontal Oscillator Disable Circuit Procedure Check** in this manual.

Service Notes

Note: These components are affixed with glue. Be careful not to break or damage any foil under the component or at the pins of the ICs when removing. Usually applying heat to the component for a short time while twisting with tweezers will break the component loose.

Leadless Chip Component (surface mount)

Chip components must be replaced with identical chips due to critical foil track spacing. There are no holes in the board to mount standard transistors or diodes. Some chips capacitor or resistor board solder pads may have holes through the board, however the hole diameter limits standard resistor replacement to 1/8 watt. Standard capacitor may also be limited for the same reason. It is recommended that identical components be used.

Chip resistor have a three digit numerical resistance code - 1st and 2nd significant digits and a multiplier. Example: 162 = 1600 or 1.6kΩ resistor, 0 = 0Ω (jumper). Chip capacitors generally do not have the value indicated on the capacitor. The color of the component indicates the general range of the capacitance.

Chip transistors are identified by a two letter code. The first letter indicates the type and the second letter, the grade of transistor.

Chip diodes have a two letter identification code as per the code chart and are a dual diode pack with either common anode or common cathode. Check the parts list for correct diode number.

Component Removal

1. Use solder wick to remove solder from component end caps or terminal.
2. Without pulling up, carefully twist the component with tweezers to break the adhesive.
3. Do not reuse removed leadless or chip components since they are subject to stress fracture during removal.

Chip Component Installation

1. Put a small amount of solder on the board soldering pads.
2. Hold the chip component against the soldering pads with tweezers or with a miniature alligator clip and apply heat to the pad area with a 30 watt iron until solder flows. Do not apply heat for more than 3 seconds.

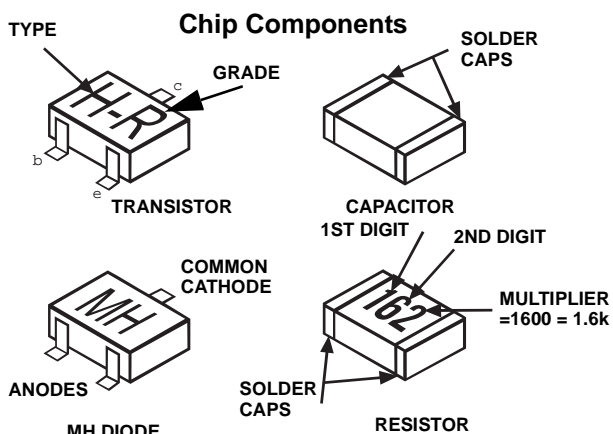

How to Replace Flat-IC

- Required Tools -

- Soldering iron
- De-solder braids
- Iron wire or small awl
- Magnifier

1. Remove the solder from all of the pins of a Flat-IC by using a de-solder braid.

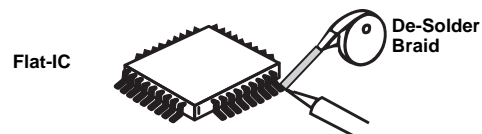

2. Put the iron wire under the pins of the Flat-IC and pull it in the direction indicated while heating the pins using a soldering iron. A small awl can be used instead of the iron wire.

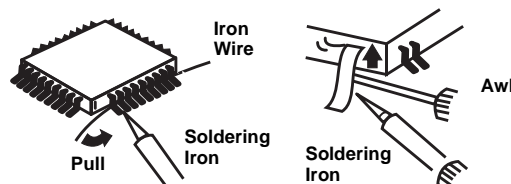

3. Remove the solder from all the pads of the Flat-IC by using a de-solder braid.

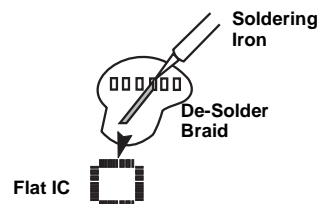

4. Position the new Flat-IC in place (apply the pins of the Flat-IC to the soldering pads where the pins need to be soldered). Properly determine the positions of the soldering pads and pins by correctly aligning the polarity symbol.

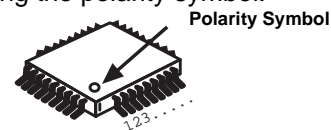

5. Solder all pins to the soldering pads using a fine tipped soldering iron.

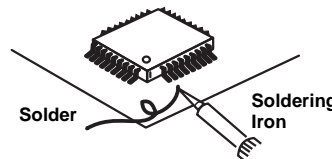

6. Check with a magnifier for solder bridge between the pins or for dry joint between pins and soldering pads. To remove a solder bridge, use a de-solder braid as shown in the figure below.

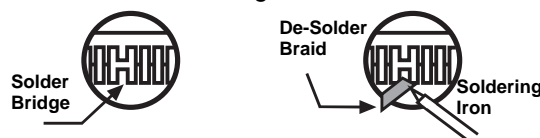

Table of Contents

Important Safety Notice	2	Initial Center Static Convergence	15
Safety Precautions	2	Purity Adjustment	15
General Guidelines	2	Final Convergence Procedure	15
Leakage Current Cold Check	2	Dynamic Convergence Adjustment	15
Leakage Current Hot Check	2	DY(YHC, YV, XV) Adjustment	15
X-ray Radiation	2	YV Adjustment (VR1 for	
Horizontal Oscillator Disable		Horizontal dynamic convergence) .	15
Circuit Test	2	YH Adjustment (VR2 for Vertical	
Service Notes	3	dynamic convergence)	15
Leadless Chip Component		XV Adjustment(precise adjustment) ..	156
(surface mount)	3	Permalloy Convergence Corrector	
Component Removal	3	Strip (Part No. 0FMK014ZZ)	17
Chip Component Installation	3	DAF Adjustment	17
How to Replace Flat-IC	3	Serviceman Mode (Electronic Controls)	19
Horizontal Oscillator Disable Circuit	6	Quick Entry to Serviceman Mode	19
 		To toggle between Aging and	
SPECIFICATIONS		Serviceman modes	19
Receiver Feature Table	7	Exiting the Serviceman Mode	19
Board Designation	8	To Check Purity	19
Location of Controls (Receiver)	9	Entering Serviceman Mode	
Quick Reference Control Operation	9	(Back-Open Method)	19
Location of Controls (Remote)	10	Service Adjustment Values	20
 		Instructional Flow Chart for	
SERVICE		Serviceman Mode	22
Disassembly for Service	11	Service Adjustments	
Back Cover	11	(Electronic Controls)	24
A-Board	11	Sub-Brightness	24
L-Board	11	Sub-Contrast	24
H-Board	11	Color Output Adjustment	24
AG-Board	11	Color Temperature Adjustment	
DG-Board	11	(B/W Tracking)	25
Q-Board	11	Complete Adjustment	25
P-Board	11	Deflection Adjustments	26
G-Board	11	H Center Adjustment	26
Speakers	12	Vertical Linearity(V-C), V-Size	
Disassembly for CRT Replacement	12	and V-Position Adjustment	26
CRT Replacement	12	V-S, V-Size Adjustment	26
Back Cover Removal	13	Trapezoid Adjustment	26
Chassis Service Adjustment Procedures	14	Parallelogram Adjustment	27
140.0V B2+ Voltage Check	14	E-W PCC Balance Adjustment	27
Source Voltage Chart	14	E-W PCC Adjustment	27
High Voltage Check	14	Corner PCC Adjustment	27
Purity and Convergence Procedure	15	H-Size Adjustment	27
When the CRT or the Yoke		MTS Circuit Adjustments	28
is Replaced	15	Input Level Adjustment	28
Vertical Raster Shift Adjustment	15	Stereo Separation Adjustment	
		(SEPAH)	28
		Sub Picture YUV output adjustment	29
		Clock Adjustment (CLOCK)	29
		Service Adjustments	
		(Mechanical Controls)	30
		Width Correction Adjustment	30
		Focus (part of T551)	30

CIRCUITS

Audio Signal Path Block Diagram	31
Video-Chroma Signal Path Block Diagram	32
IIC Connection	33
IC001 IN/OUT Pins and Functions (MPU)	34
Identification of Components	35
Parts List	39
Foldouts Notes	54
Connection Diagram	55
Connectors Description	56

FOLDOUTS

Schematics, Voltages & Waveforms

L-Board Schematic, Layout & Voltages	57
A-Board Schematic (Left Portion)	58
A-Board Schematic (Right Portion) & Voltages	59
A-Board Layout	60
G-Board Schematic, Layout & Voltages	61
D-Board Schematic (Left Portion)	62
D-Board Schematic (Right Portion) & Voltages	63
D-Board Layout	64
P-Board Schematic & Voltages	65
Q-Board Schematic & Voltages	66
P & Q-Board Layouts	67
AG-Board Schematic & Voltages	68
H-Board Schematic & Voltages	69
AG-Board Layout	70
H-Board Layout	71
Waveforms	72
Parts List Abbreviations Guide	75

Service Notes (Continued)

IMPORTANT: To protect against possible damage to the solid state devices due to arcing or static discharge, make certain that all ground wires and CTR DAG wire are securely connected.

CAUTION: The power supply circuit is above earth ground and the chassis cannot be polarized. Use an isolation transformer when servicing the Receiver to avoid damage to the test equipment or to the chassis. Connect the test equipment to the proper ground (Hot \oplus) or (Cold \ominus) when servicing, or incorrect voltages will be measured.

WARNING: This Receiver has been designed to meet or exceed applicable safety and X-ray radiation

protection as specified by government agencies and independent testing laboratories.

To maintain original product safety design standards relative to X-ray radiation and shock and fire hazard, parts indicated with the symbol \triangle on the schematic must be replaced with identical parts. Order parts from the manufacturer's parts center using the parts numbers shown in this service manual, or provide the chassis number and the part reference number.

For optimum performance and reliability, all other parts should be replaced with components of identical specification.

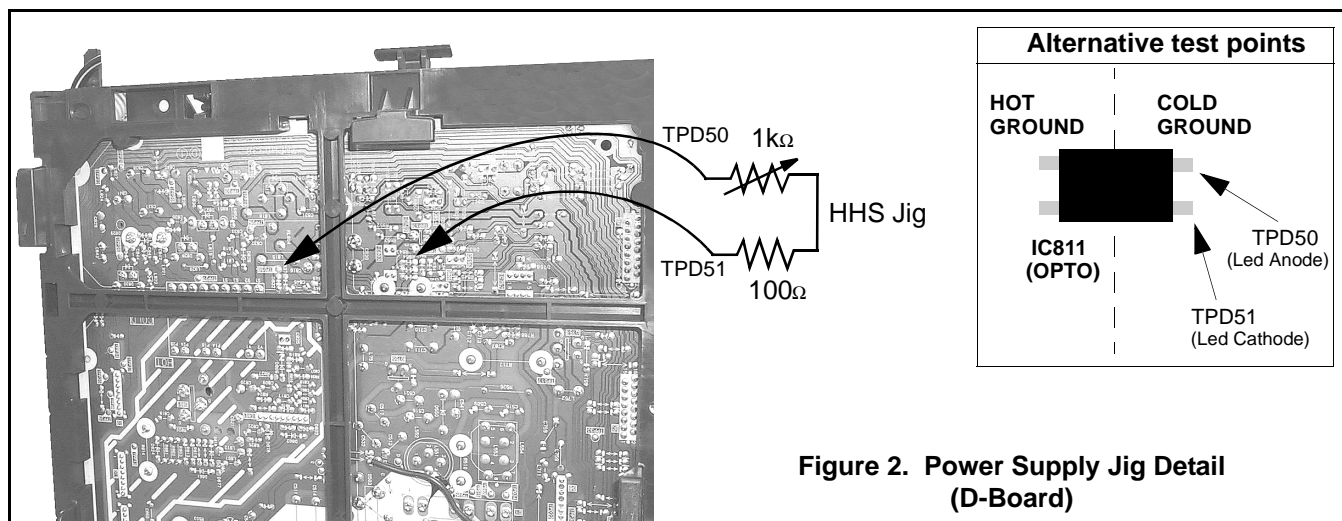

Figure 2. Power Supply Jig Detail (D-Board)

Horizontal Oscillator Disable Circuit

This chassis employs a special circuit to protect against excessive high voltage and beam current. If, for any reason, the high voltage and beam current exceed a predetermined level this protective circuit activates and detunes the horizontal oscillator that limits the high voltage. The over-voltage protection circuit is not adjustable. However, if components indicated by the symbol \triangle on the schematic in either the horizontal sweep system or the over-voltage protection circuit itself are changed, the operation of the circuit should be checked using the following procedure:

Equipment needed to check the disabled circuit:

1. High Voltage Meter (0- 50kV)
2. Variac or Isolation Transformer
3. 1k ohm VR
4. DC Ammeter

Preparation

1. Connect Receiver to AC 120 Volts. Do not turn ON.
2. Connect HIGH VOLTAGE meter to 2nd anode (H.V. button). **Note:** Use cold ground(\ominus) for negative lead.
3. Connect the ammeter serial from the flyback anode lead to the picture tube anode socket.
4. Prepare HHS jig to be connected between TPD50 and TPD51 as shown above.

Procedure:

1. Open Connector A17.
2. Turn power ON and Apply a monoscope pattern.
3. Set current within 50-100 μ A by changing the picture and bright controls.
4. Turn power OFF.
5. Connect HHS jig between **TPD50** and **TPD51** as shown above (VR should be turn fully clockwise).
6. Turn power on.
7. Using the variable resistor slowly increase the current until the horizontal sync frequency abruptly increases indicating that the horizontal frequency is just beginning to pull out of sync. Maintain the current within 50-100 μ A by changing the picture and bright controls
8. Observe the High Voltage meter. **HIGH VOLTAGE** should read less than **40.2kV**.
9. Turn power OFF, Remove HHS jig, HV meter, ammeter and connect A17 connector.
10. Turn Power ON. Reset Picture and Brightness controls. Confirm **B+ 144V \pm 1.5V** with 120V AC applied.

Note: **IF HIGH VOLTAGE IS NOT WITHIN THE SPECIFIED LIMIT THE CAUSE MUST BE DETERMINED BEFORE THE RECEIVER IS RETURNED TO THE OWNER.**

Receiver Feature Table

FEATURE\MODEL	CT-32HX40B/CB	CT-36HX40B/CB
Chassis	DX2P	
Tuning system	256K	
# of channels	181	
Menu language	ENG/ESP/FR	
Closed Caption	X	
V-Chip (USA/CANADA)	X	
Picture in Picture PIP	2T	
2RF	X	
Remote Model #	EUR511158	
Picture tube	M80LSW195X	A90LSW195X
Flat/Superflat	F (4:3)	
Comb	3D Y/C	
H. Edge Correction	W/VEC	
NEW Y NR	X	
VM	X	
Color Temp	X	
V/A norm (X=both)	X	
MTS/SAP/DBX	X	
Built-in audio power	15W/CH(10%)	
# of speakers	2	
Bass/BI/Tre Control	X	
AI Sound	X	
Spatializer	X	
A/V in (rear/front)	4(3/1)	
A/V Prog Out	X	
Component Input	2	
Audio Out (FAO,VAO)	F,V	
S-VHS Input (rear/front)	2/1	
Dolby Center Ch In	X	
EPJ/HPJ/MISC	HPJ	
Dimensions (HxWxD)	mm 667.3x810x568 in 26.52x32.4x22.72	747x936x610.5 29.88x37.44x24.42
Weight (kg/lbs)	74.8/164.56	98.5/216.7
Power source (V/Hz)	120/60	
Anode voltage	31.0kV (+1.0kV, -2.0kV)	
Video input jack	1 V _{p-p} 75Ω phono jack	
Audio input jack	500mV RMS 47kΩ	

Table 1. Receiver Features

Board Designation

Board	32" & 36" Models	Description
A-Board	TNPH0337	Main Chassis
L-Board	TNPA1667	CRT Drive
P-Board	TNPA1666	Power Supply
H-Board	TNPA1664	A/V Switch
G-Board	TNPA1670	Keyboard, Video-4 Input, Speaker connector, Geomagnetic
D-Board	TNPH0338	Deflection, Sweep, Power Supply, H-Drive
Q-Board	TNPA1665	Geometry, V-Drive
AG-Board	TNPA1668	Chroma
DG-Board	TNPA1669	Non-Serviceable Comb Filter, Digital Processing, PIP Processing

Specifications are subject to change without notice or obligation.
Dimensions and weights are approximate.

Location of Controls (Receiver)

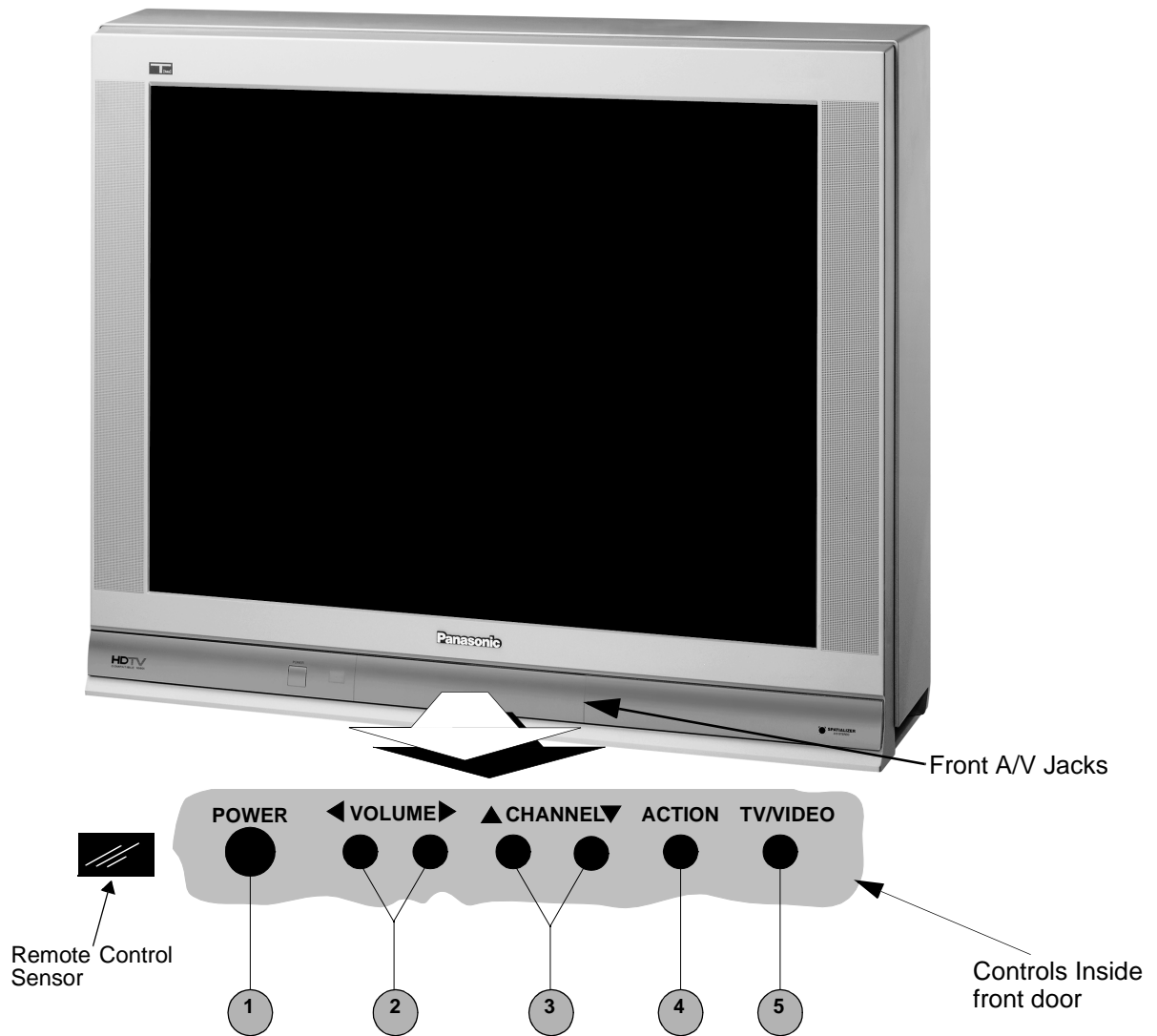

Figure 3. Location of Controls Receiver
Quick Reference Control Operation

Quick Reference Control Operation

- 1 **Power Button** - Press to turn ON or OFF.
- 2 **Volume Buttons** - Press to adjust Sound Level, or to adjust Audio Menus, Video Menus, and select operating features when menus are displayed
- 3 **Channel Buttons** - Press to select programmed channels. Press to highlight desired features when menus are displayed. Also use to select Cable Converter box channels after programming Remote Control Infrared codes (the TV/AUX/CABLE switch must be set in CABLE position).
- 4 **Action Button** - Press to display Main Menu and access On Screen feature and Adjustment Menus.
- 5 **TV/Video Button** - Press to select TV or one of two Video Inputs, for the Main Picture or the PIP frame (when PIP frame is displayed).

Location of Controls (Remote)

POWER Button
Press to turn ON and OFF.
MUTE Button
Press to mute sound. A second press resumes sound. Press also to access and delete Closed Caption display.
VCR, DVD, LD/CD, AUX, TV, CBL, DBS, RCVR
Component function buttons
VOL (volume) Buttons
Press to adjust TV sound level. Use with Channel buttons to navigate in menus.
R-TUNE (Rapid Tune) Button.
Press to switch to the previous channel.
ACTION Button
Press to display Main Menu and access or exit On Screen features and Adjustment Menus.
REW, PLAY, FF, TV/VCR, STOP, PAUSE, REC, VCR CHANNEL
Component function buttons.



LIGHT
Press to light Remote control buttons
MULTI Button
Programmable button that can operate up to seven (7) functions at once
TV/VIDEO Button
Press to select TV or Video input.
CH (channel) Buttons
Press to select channels. Use with volume buttons to navigate in menus.
DBS EXIT, DBS GUIDE
DBS function buttons.
RECALL Button
Press to display Time, status of Sleep Timer, Channel, Video mode and Channel Caption (Station Identifier).
OPEN/CLOSE, SLOW, STILL
DVD function buttons.
"0" - "9"
Press numeric keypad to select any channel.

EUR511158

Figure 4. Location of Controls (Remote)

For more functions and information about this Remote Control, refer to the Remote Guide listed in Parts List of this manual

Disassembly for Service

Back Cover

Remove all the screws marked with an arrow(←) from the back of the Receiver. (See Fig. 8)

Note: Screw configuration, type, and number of screws vary depending on the model of the Receiver serviced and the application; various models are covered in this Manual. Use same hardware when reassembling the receiver.

- 4 screws at the top edge of the Receiver.
- 4 screw by the A/V jacks.
- 1 screw by the antenna jacks.
- 1 screw by the Dolby Center Ch Input.
- 1 screw at the lower part of TV.
- 1 screw at each lower corner of the Receiver.
- 1 screw by the retainer plate of the AC power cord.
- 1 screw by the AC Cord assembly.

Note: Extensions for board connectors may be needed to take voltages on H-Board, AG-Board, Q-Board and P-Board, please see Parts List section for part numbers in this Service Manual.

A-Board - Main Chassis (See Fig. 49)

The H, AG and DG-Board are assembled on the Main chassis (A-Board). When servicing these boards, extension cables may be required. Cables kit can be ordered from Matsushita Services Company, Part No. TXAZS011SER. The A-Board assembly rest on a chassis tray along with the D-Board.

Slide chassis tray out. Gently lift, tray and pull out. Disconnect plug connectors; release wire ties and holders as required for complete chassis removal.

- A. A-Board is secured to the chassis tray with five screws.
- B. The D-Board is secured to the chassis tray with five screws
- C. The A-Board is mated to the D-Board by four flexible connectors: A4, A5, A6 & A7 (D4, D5, D6 & D7 on the D-Board, respectively). To remove either boards, unplug the connectors on the A-Board.

Note: Some tie-wraps that secure the wire dressings may need to be unfastened for chassis removal.

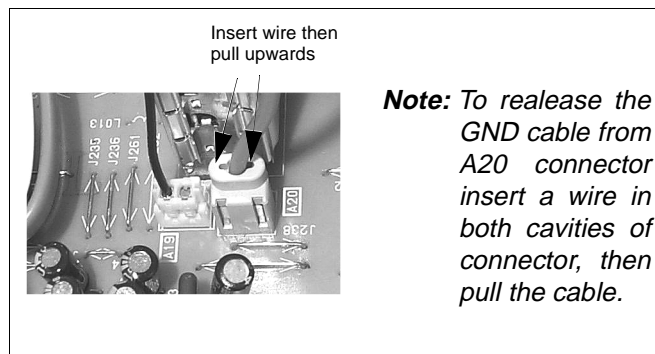

L-Board - CRT Output

Plugs into the socket on the CRT neck.

To remove this board, first unplug the board from the CRT neck, then disconnect L1, L2 & L3 connectors, to disconnect the focus F1(Red Cable) & F2(White Cable) cables, pull the tab and release the cables, finally disconnect the screen cable from the D-Board D16.(See Fig. 6).

To reinsert back the cables, remember the original position of cables, F1(red cable) goes to A on the CRT socket and F2(white cable) goes to B on the CRT socket.

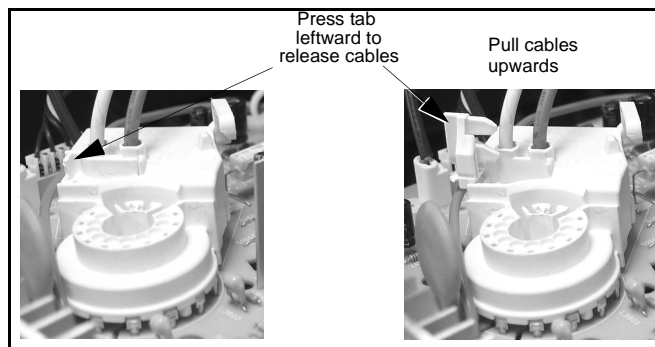

Figure 5. F1 & F2 cables release

To release screen GND cables from L-Board L11 & L12 connectors, insert a wire in both sides of connector and pull upwards the cable, then remove the wire (See Fig. 6)

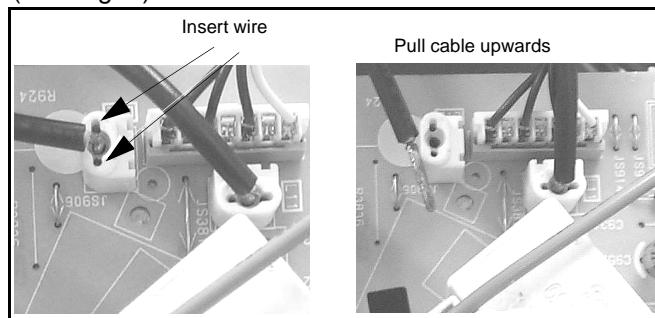

Figure 6. L-Board Screen GND cables release

H-Board - A/V Jacks, S-Video Connectors, and S-Video Switch

Plugs onto A-Board at the A9 connector.

Note: Use a small flat head screwdriver to release the connector locking tabs.

AG-Board

Plugs onto A-Board at the A25 & A26 connectors.

Note: Use a small flat head screwdriver to release the connector locking tabs.

DG-Board

Plugs onto the A-Board at the A10 connector.

Note: This Board is Not-Serviceable.

When removing this board pull carefully.

Q-Board

Plugs onto the D-Board at the D8, D9 & D10 connectors.

P-Board

Plugs onto the right side of the D-Board at D1, D2 & D3 connectors; First remove the three screws that holds the metal board, one from the flyback

and two from the chassis tray and then use a flat head screwdriver to release the connector locking tabs and pull upwards the board.

G-Board

Mated to A-Board by three flexible connectors. To remove this board, first unplug the three flexible connectors, then pull upwards the board while unlock the tabs from the chassis tray.

Speakers

Each speaker is secured to a plastic base with 4 screws, and each plastic base is secured to a second base with two screws, and secured to the cabinet with two screws.

Note: Be sure to reconnect the speaker wires to the correct speaker lead (+) (-)

Disassembly for CRT Replacement

1. Discharge the CRT as instructed in the **Safety Precautions** (see page 2) and remove 2nd anode button from the CRT.
2. Remove Speaker Modules (R & L)
3. Perform complete removal of Chassis, as instructed in **Disassembly for Service**.

Note: When remounting the CRT, reuse the metal sheet located in the lower part of the cabinet holding the CRT, hold with screws to the cabinet. This metal sheet is not supplied with the CRT replacement.

CRT Replacement

1. Perform **Disassembly for CRT Replacement** procedure.
2. Insure that the CRT H.V. Anode button is discharged before handling the CRT. Read the **Safety Precautions** (see page 2) on handling the picture tube.
3. Remove the components from the CRT neck and place the cabinet face down on a soft pad.
4. Note the original order for the CRT mounting hardware as they are remove from the CRT mounting brackets at each corner of the CRT.
5. Remove the CRT with the degaussing coil and the dag ground braid attached.

Note: To remove the four brackets holding the degauss coil from the corners of the CRT, first remove the CRT from the cabinet, then remove the Brackets by pressing the tab on the bracket and pull upwards. These Brackets are included in the Degauss Coil Kit, for part number, please see parts list section (See Fig. 7).

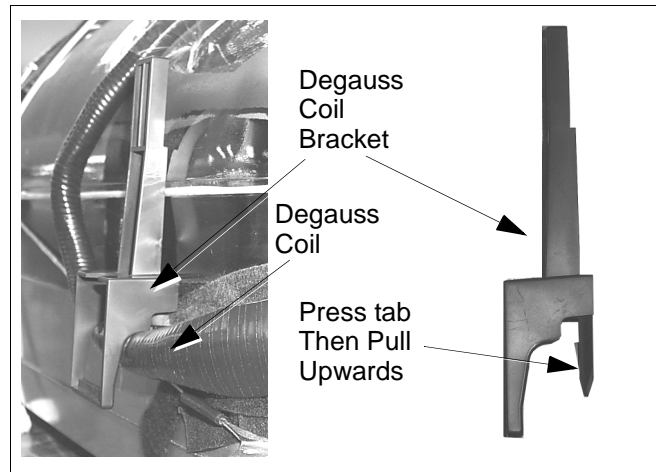

Figure 7. Brackets removal

6. Note the original locations and mounting of the degaussing coil and the dag ground assembly to insure proper reinstallation on the replacement CRT.
To remove and remount the degaussing coil: The degaussing coil is held in place by clampers fastened to the CRT corner ears. These clampers must be installed onto the replacement CRT prior to mounting the degaussing coil.
To remove and remount the dag ground braid:
 - a. Unhook the coil spring from the bottom corners of the CRT ears.
 - b. Release the braid loop from the upper corners of the CRT ears.
7. Mount the dag ground braid on the replacement CRT. Position the degaussing coil with new ties. Dress coil as was on the original CRT.
8. Replace the components on CRT neck and reinstall into cabinet. Verify that all ground wires and circuit board plugs get connected.

Note: Reuse all the clampers and mounting brackets from the degauss coil and screen, and when remounting the degauss coil assure that is not touching the speakers, this can be done by placing some tape (See Fig. 7), this may cause mask vibration. The mounting brackets and clampers are not supplied with the replacements.

Important Notice:

When ordering the CRT, please order CRT and CRT KIT also. Please see parts list section for part numbers

Back Cover Removal

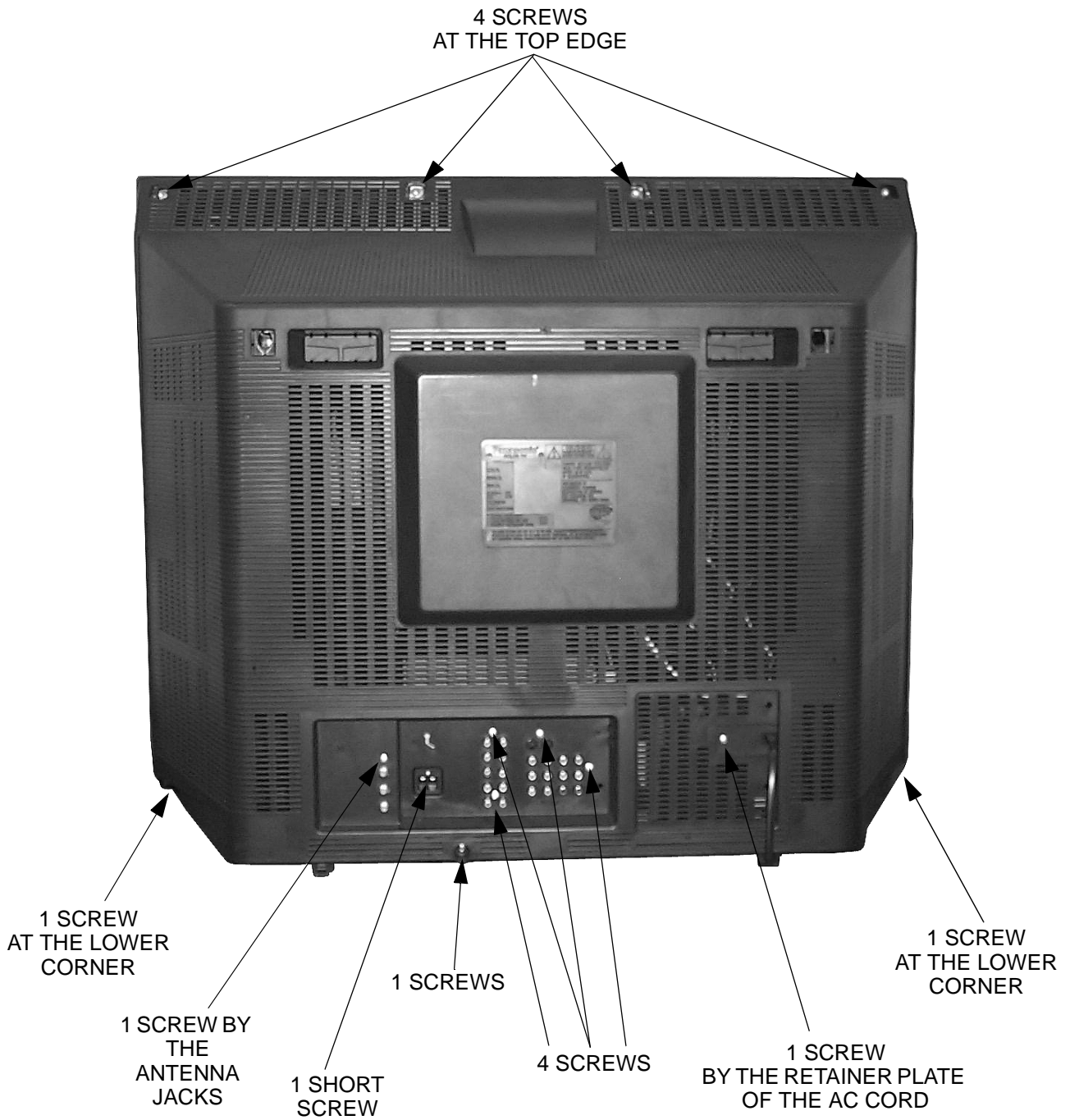
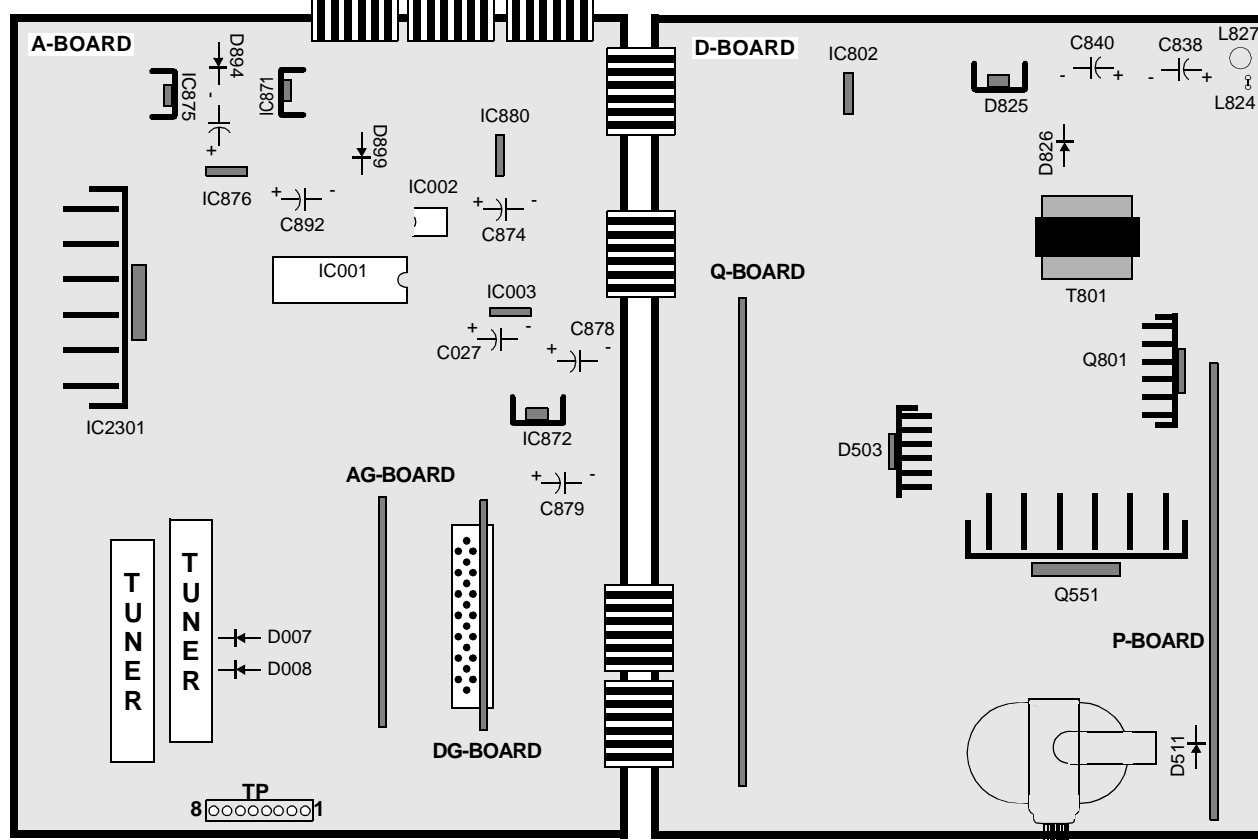

Figure 8. Back Cover Removal.

Chassis Service Adjustment Procedures

All service adjustments are factory preset and should not require adjustment unless controls and/or associated components are replaced.

Note: Connect the (-) lead of the voltmeter to the appropriate ground. Use Q801's heat sink when the HOT ground symbol (↕) is used. Otherwise, use COLD ground (↗) — Tuner shield, IC2301's heat sink (See Fig. 50)



MOMENTARILY CONNECT A JUMPER FOR ENTERING SERVICE MODE (FA1 to FA2)

140.0V B2+ Voltage Check

1. Set the **Bright** and **Picture** to Minimum by using the Picture Menu.
2. Connect the DVM on **TPP17** (D-Board) and cold ground (↗).
3. Confirm that B2+ voltage is **144.0V ± 1.5V**. This voltage supplies B2+ to the Horizontal Output & Flyback circuits.

Source Voltage Chart

120V AC line input. Set the **Bright** and the **Picture** to Minimum by using the Picture Menu. Use cold (↗) or Hot (↕) ground for the (-) lead of the DVM as needed.

LOCATION	VOLTAGE
MAIN 12V (IC876 PIN-2) A-Board TPA6	12.0 ± 0.5V
MAIN 9V (CATHODE D894) A-Board TPA7	9.0V ± 0.5V
MAIN 5V (IC872 PIN-1) A-Board TPA8	5.0V ± 0.3V
MAIN 3.3V (IC872 PIN-2) A-Board TPA14	3.5V ± 0.2
GC 3.3V (IC880 PIN-2) A-Board TPA15	3.5V ± 0.2V
STBY 3.3V (IC003 PIN-4) A-Board TPA16	3.3 ± 0.2V

LOCATION	VOLTAGE
STBY 5.0V (IC002 PIN-8) A-Board TPA17	5.0 ± 0.2V
BTL 30V (CATHODE D007) A-Board TPA18	32.0V ± 2.0V
+B2 (BY IC802 & Q854) D-Board TPP17	144.0V ± 1.5V
40V (CATHODE D826) D-Board TPP25	40.0V ± 3.0V
25V (BY D825) D-Board TPP19	26.8V ± 2.0V
15V (BY C840 & L826) D-Board TPP20	15.0V ± 1.5V
-15V (BY C838 & C838) D-Board TPP21	-15.1V ± 1.5V
SOUND (BY L827 & L824) D-Board TPP22	32.5V ± 2.0V
220V (CATHODE D511) D-Board TPD7	220.0V ± 9.0V

High Voltage Check

1. Select an active TV channel and confirm that horizontal is in sync.
2. Adjust Brightness and Picture using Picture Icon menu so video just disappears.
3. Confirm B2+ 144 ± 1.5V is within limit.
4. Using a high voltage meter confirm that the High Voltage is **31.0kV ± 1.0kV**.

Purity and Convergence Procedure

Adjustment is necessary only if the CRT or the deflection yoke is replaced or if the setting was disturbed. The complete procedure consists of:

1. Vertical Raster Shift Adjustment.
2. Initial static convergence.
3. Setting the purity.
4. Final static convergence.

When the CRT or the Yoke is Replaced

Place the yoke on the CRT neck (do not tighten the clamp).

Place the vertical raster shift tabs at 3 o'clock (90° from the purity and convergence tabs (See Fig. 9 and Fig. 10)

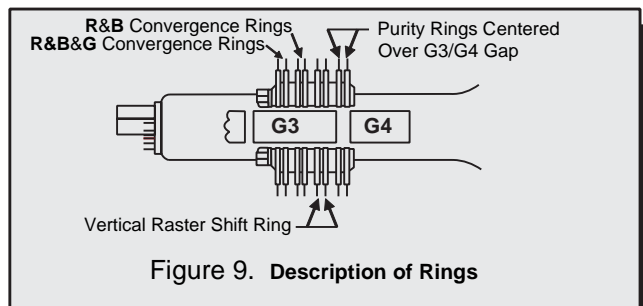

Figure 9. Description of Rings

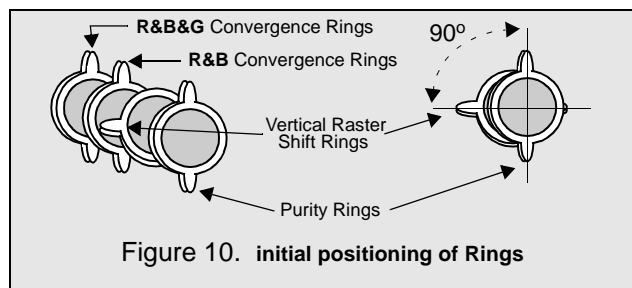

Figure 10. Initial positioning of Rings

Turn the Receiver ON. Operate the Receiver for 60 minutes using the first Purity Check field (white screen) to stabilize the CRT.

Fully degauss the Receiver by using an external degaussing coil.

Slide the deflection yoke back and forth on the neck of the CRT until it produces a near white, uniform raster.

Vertical Raster Shift Adjustment

Apply a green pattern with a horizontal line, adjust the Deflection Yoke so that has no tilt, then secure it.

Adjust center line of the pattern with the mechanical center of the CRT, this center is determined by two marks at the side edges of the screen. To adjust the line, once the vertical raster shift tabs are place at 3 o'clock to reduce its magnetic field effect (see Fig. 9) open the tabs the same angle from the center, until the center line of the pattern becomes a straight line, centered with the marks of the CRT. (see Fig. 10)

Important Notice:

Rings come along with Deflection Yoke in one piece.

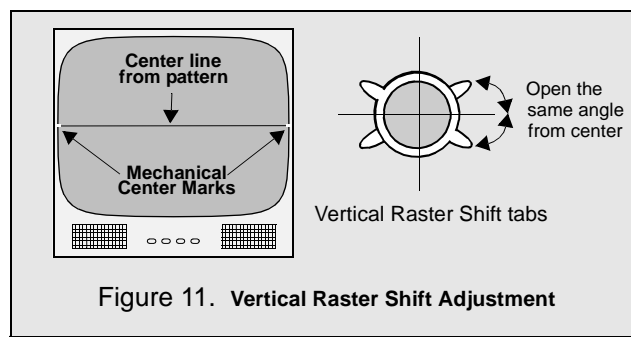

Figure 11. Vertical Raster Shift Adjustment

Initial Center Static Convergence

Connect a dot/cross hatch generator to the Receiver and tune in a signal. Observe misconvergence at center of the screen only.

Adjust the R&B pole magnets; by separating tabs and rotating to converge blue with red.

Adjust the R&B and R&B&G pole magnets: by separating tabs and rotating to converge blue and red (magenta) with green.

Note: Precise convergence at this point is not important.

Purity Adjustment

When the Receiver is in the Serviceman Mode for making electronic adjustments, press the **Recall** button on the Remote Control to enter Purity Check. (See the **Service Adjustments Electronic Controls** procedure).

Operate the Receiver for 60 minutes using the first Purity Check field (white screen) to stabilize the CRT.

Fully degauss the Receiver by using an external degaussing coil.

Press the **Recall** button on the Remote Control again until the Purity Check (green screen) appears.

Loosen the deflection yoke clamp screw and move the deflection yoke back as close to the purity magnet as possible.

Adjust the Purity rings to set the vertical green raster precisely at the center of the screen (see Fig. 12).

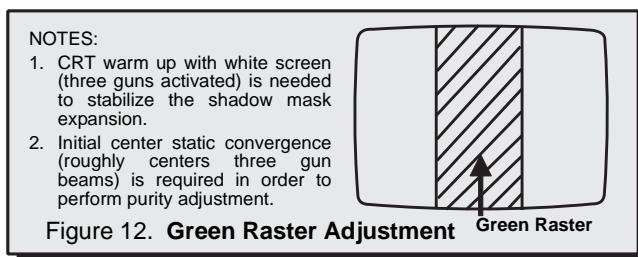

Slowly move the deflection yoke forward until the best overall green screen is displayed.

Tighten the deflection yoke clamp screw.

Press the **Recall** button on the Remote Control again until the purity check blue and red screens appear and observe that good purity is obtained on each respective field.

Press the **Recall** button on the Remote Control again until Purity check (white screen) appears. Observe the screen for uniform white. If purity has not been achieved, repeat the above procedure.

Final Convergence Procedure

Note: Vertical size and focus adjustments must be completed prior to performing the convergence adjustment. Connect a dot pattern generator to the Receiver. The **Brightness** level should not be higher than necessary to obtain a clear pattern.

Converge the red and the blue dots at the center of the screen by rotating the R&B pole Static Convergence Magnets.

Align the converged red/blue dots with the green dots at the center of the screen by rotating the R&B&G pole Static Convergence Magnets. Melt wax with soldering iron to reseal the magnets.

Slightly tilt vertically and horizontally (do not rotate) the deflection yoke to obtain a good overall convergence.

If convergence is not reached at the edges, insert permalloy in the DY corners to achieve proper convergence (See "Permalloy Convergence Corrector Strip (Part No. 0FMK014ZZ)" on page 17.) Recheck for purity and readjust if necessary.

After vertical adjustment of the yoke, insert wedge at 11 o'clock position, then make the horizontal tilt adjustment.

Secure the deflection yoke by inserting four side wedges.

Apply adhesive between tab (thin portion) of wedge and CRT and place tape over the tab to secure to the CRT.

Dynamic Convergence Adjustment

Use this for a precisely overall convergence adjust at the edges.

DY(Y_{HC} , Y_v , X_v) Adjustment

Y_v Adjustment (VR1 for Horizontal dynamic convergence)

1. Apply a crosshatch pattern.
2. Adjust contrast and brightness customer controls to obtain a correct picture.
3. With a driver adjust VR1 (located in deflection yoke board Fig. 19) to obtain a proper convergence at top and bottom of the screen (See Fig. 13)

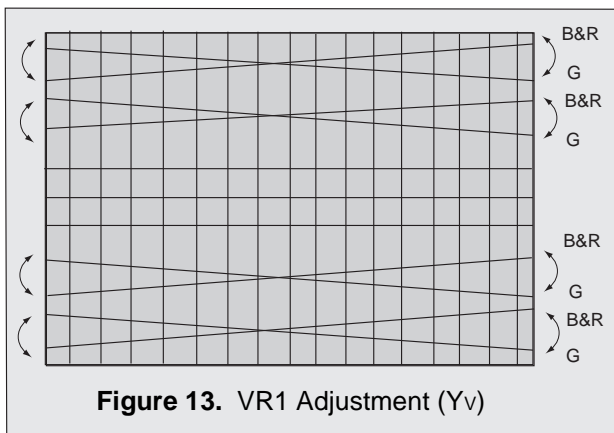

Y_H Adjustment (VR2 for Vertical dynamic convergence)

1. Apply a crosshatch pattern.
2. Adjust contrast and brightness customer controls to obtain a correct picture.
3. With a driver Adjust VR2 (located in deflection yoke board Fig. 19) to obtain a proper convergence at left and right side of the screen. (See Fig. 14)

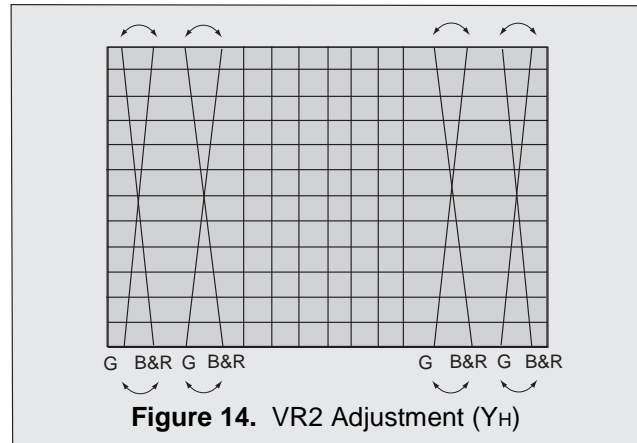

X_v Adjustment (precise adjustment)

1. Apply a crosshatch pattern.
2. Adjust contrast and brightness customer controls to obtain a correct picture.
3. With a driver adjust the coil located in deflection yoke board to obtain a proper convergence horizontally.

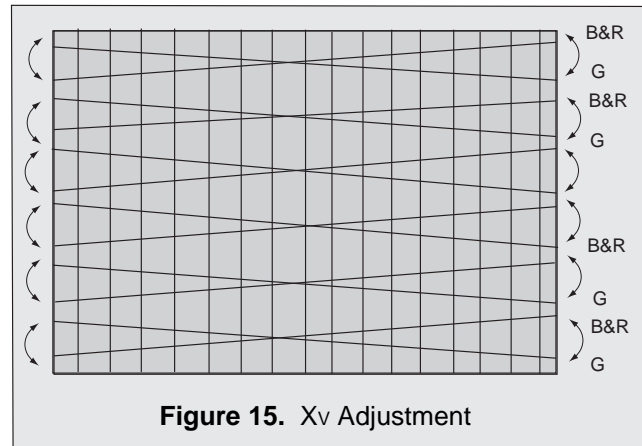

Note: Apply a red pattern and confirm purity, if purity is poor, repeat purity adjustments.

Permalloy Convergence Corrector Strip (Part No. 0FMK014ZZ)

This strip is used in some sets to match the yoke and CRT for optimum convergence. If the yoke or CRT is replaced, the strip may not be required.

First converge the set without the strip and observe the corners.

If correction is needed:

1. Place strip between CRT and yoke, in quadrant needing correction. Slowly move it around for desired results.
2. Press adhesive tightly to the CRT and secure with tape.

DAF Adjustment

Preparation:

1. Apply a crosshatch pattern.
2. Set user controls, bright to center and picture to max.

Procedure:

1. Connect channel one of the oscilloscope with 100x1 probe to D1505A (DAF waveform).
2. Connect channel two of the oscilloscope with 10x1 probe to D504K or R519 (FBP waveform).
3. If the peak position of the waveforms are different, in Serviceman Mode, adjust "HDAFC" DATA so that become the same position. (See Fig. 16)

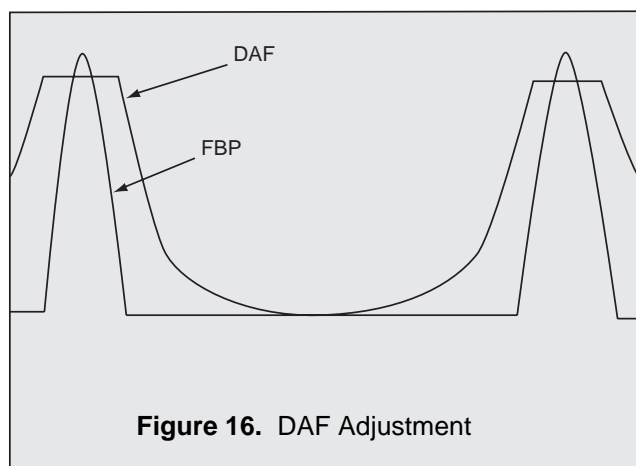
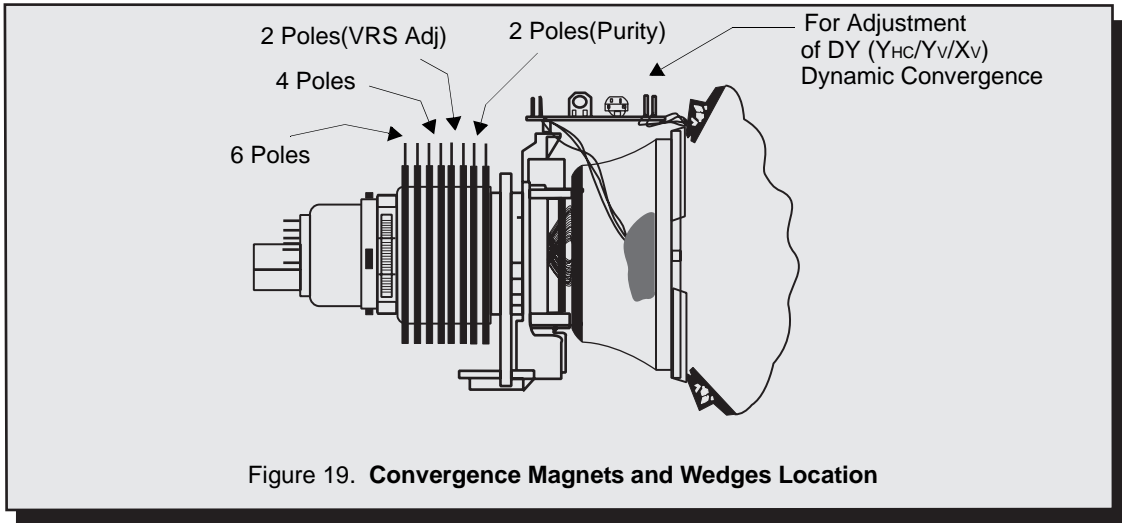
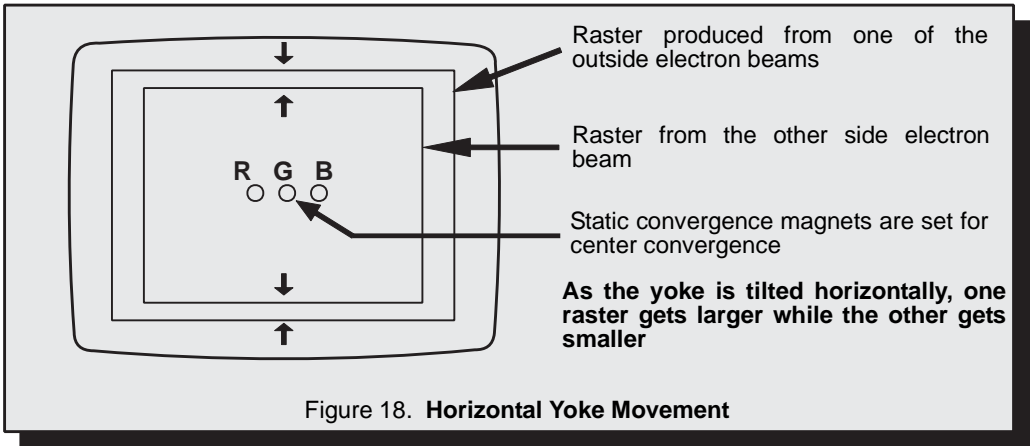
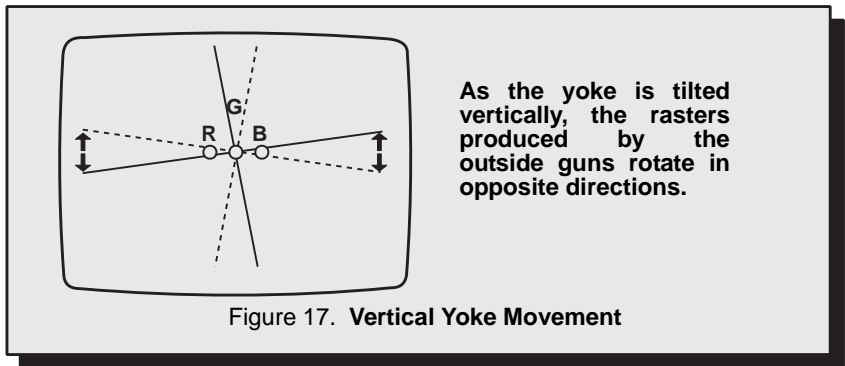

Figure 16. DAF Adjustment



IMPORTANT NOTE:
Always Exit the Serviceman Mode Following Adjustments.

Serviceman Mode (Electronic Controls)

This Receiver has electronic technology using the I²C Bus Concept. It performs as a control function and it replaces many mechanical controls. Instead of adjusting mechanical controls individually, many of the control functions are now performed by using "On Screen Display Menu". (The **Serviceman Adjustment Mode**.)

Note: It is suggested that the technician reads all the way through and understand the following procedure for Entering/Exiting the **Serviceman Adjustment Mode**; then proceed with the instructions working with the Receiver. When becoming familiar with the procedure, the Flow Chart for Serviceman Mode may be used as a quick guide.

Quick Entry to Serviceman Mode:

When minor adjustments need to be done to the electronic controls, the method of Entering the serviceman Mode without removal of the cabinet back is as follows using the Remote Control:

1. Select SET-UP icon and select CABLE mode.
2. Select TIMER icon and set SLEEP time for 30 Min.
3. Press "ACTION" twice to exit menus.
4. Tune to the Channel 124.
5. Adjust VOLUME to minimum (0).
6. Press VOL ◀ (decrease) on Receiver. Red "CHK" appears in upper corner.

Note: After Receiver is set into SERVICEMAN mode, set TIMER back to NO.

To toggle between Aging and Serviceman modes:

While the "CHK" is displayed on the left top corner of the CRT, pressing "ACTION" and "VOL" UP on the TV simultaneously will toggle between the modes. Red "CHK" for Serviceman and yellow

7. Press Power on the Remote Control to display the Serviceman Adjustment Modes menu, select adjustment by pressing the volume right/left buttons and channel up/down buttons on the remote and ACTION to enter the adjustment.

MODE	480I	480P	1080I	
MTS	4:3	16:9	DW	
CLOCK	MTSIN	SEPAL	SEPAH	
VIDEO	CLOCK			
	COLOR	BRIGHT	TINT	CONT
	B-Y_G	CUT G	CUT R	CUT B
	BRT	R DR	B DR	
SUB	Y DRV	UVDRV		
HDEF	H LIN	H POS	H WID	PCC
	PCCHG	PCCLG	PCCHS	PCCLS
	TOPG	BTMG	TOPSL	BTMSL
	TRAP	PARA	SIDE	
VDEF	V RAS	VEAMP	V-C	V-S
DAF	HDAFC	VDAFG		

Figure 20. Serviceman Mode Menu Adjustments.

Note: Some adjustments are available only in some modes (480i, 480p, 1080i); it is needed to apply the format.

Exiting the Serviceman Mode:

Press Action and Power on the Receiver simultaneously for at least 2 seconds.

THE RECEIVER EXITS SERVICEMAN MODE.

The Receiver momentarily shuts off; then comes back on tuned to channel 3 with a preset level of sound. Any programmed channels, channels caption data and some others user defined settings will be erased.

IMPORTANT NOTE:
Always Exit the Serviceman Mode Following Adjustments.

To Check Purity:

Press Recall on the Remote Control when in Serviceman Mode (red "CHK" is displayed) to enter the Purity Field Check Mode.

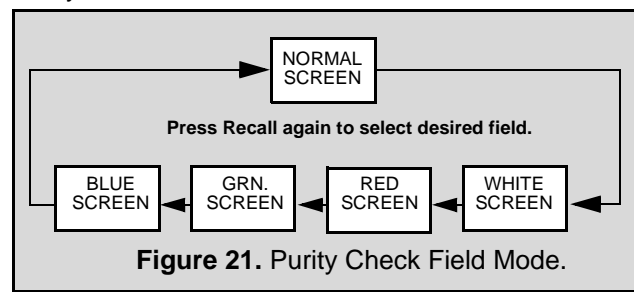

Figure 21. Purity Check Field Mode.

Helpful Hints

Entering Serviceman Mode (Open-Back Method)

- While the Receiver is connected and operating in Normal Mode, momentarily short test point FA1 to Cold Ground (↗) (A-Board).

The Receiver enters the Aging Mode.

Yellow letters "CHK" appear in the upper left corner of the screen.
(The Volume, Up/Down will adjust rapidly).

For Adjustments:

1. Press **Channel Up/Down** and **Volume Right/Left** on the **Remote Control** to select one of the available Service Adjustments (Fig. 20). Press **ACTION** to enter the adjustment. Press **ACTION** again to go back to the adjustments menu (Fig. 20).

Note: Write Down the original value set for each address before modifying anything. It is easy to erroneously adjust the wrong item.

2. Press **Volume Right/Left** on the **Remote Control** to adjust the level of the selected Service Adjustment (Fig. 20).

MTS Adjustments	Description	Mem Loc.	Default Level	New Level
MTSIN	INPUT LEVEL	AE 0E	09	
SEPAL	LOW FREQ SEPARATION	AE 0F	1F	
SEPAH	HI FREQ SEPARATION	AE 10	1F	
CLOCK Adjustments	Description	Mem Loc.	Default Level	New Level
CLOCK	SYNTHESIZER ADJUST.	AE 12	128	
VIDEO Adjustments	Description	Mem Loc.	Default Level	New Level
COLOR	COLOR	AA 8F	24	
TINT	TINT	AA 91	1F	
BRIGHT	SUB-BRIGHTNESS	AA 93	60	
CONT	SUB-CONTRAST	AA 95	22	
B-Y_G	COLOR ADJUST. (BLUE)	AA AE	2F	
CUT G	GREEN CUT-OFF	AA CC	02 D2	
CUT R	RED CUT-OFF	AA C8	02 92	
CUT B	BLUE CUT-OFF	AA D0	02 56	
BRT	TEMPORARY BRIGHTNESS	DOES NOT WRITE TO EEPROM	60	
R DR	RED DRIVE	AA 96	B1	
B DR	BLUE DRIVE	AA 98	AD	
H DEF Adjustments	Description	Mem Loc.	Default Level	New Level
H LIN	HORIZONTAL LINEARITY	AA 76	5F	
H POS	HORIZONTAL CENTERING	A6 EA	37	
H WID	HORIZONTAL WIDTH	A8 32	4F	
PCC	PINCUSHION CORRECTION	A8 30	48	
PCCHG	PINCUSHION TOP GAIN	A8 56	02	
PCCLG	PINCUSHION BOTTOM GAIN	A8 60	01	
PCCHS	PINCUSHION TOP SLICE LEVEL	A8 B6	00	
PCCLS	PINCUSHION BOTTOM SLICE LEVEL	A8 B1	01	

For Adjustments:

1. Press **Channel Up/Down** and **Volume Right/Left** on the **Remote Control** to select one of the available Service Adjustments (Fig. 20). Press **ACTION** to enter the adjustment. Press **ACTION** again to go back to the adjustments menu (Fig. 20).

Note: Write Down the original value set (Fig. 20) for each address before modifying anything. It is easy to erroneously adjust the wrong item.

2. Press **Volume Up/Down** on the **Remote Control** to adjust the level of the selected Service Adjustment (Fig. 20).

H DEF Adjustment	Description	Mem Loc.	Default Level	New Level
TOPG	TOP CORNER GAIN	A8 A2	13	
BTMG	BOTTOM CORNER GAIN	A8 AC	11	
TOPSL	TOP CORNER SLICE LEVEL	A8 46	01	
BTMSL	BOTTOM CORNER SLICE LEVEL	A8 3C	0B	
TRAP	TRAPEZOID	A8 2B	75	
PARA	PARALLELOGRAM	A8 65	07	
SIDE	PINCUSHION BALANCE ADJUST.	A8 6A	00	
VDEF Adjustments	Description	Mem Loc.	Default Level	New Level
VRAS	VERTICAL CENTERING	AA 72	27	
VEAMP	VERTICAL WIDTH	A8 14	62	
V-C	VERTICAL LINEARITY_1	A8 7E	22	
V-S	VERTICAL LINEARITY_2	A8 74	1E	
DAF Adjustments	Description	Mem Loc.	Default Level	New Level
HDAFC	HORIZONTAL DAF	A8 05	17	
VDAFG	VERTICAL DAF	A8 C5	AA	

Instructional Flow Chart for Serviceman Mode

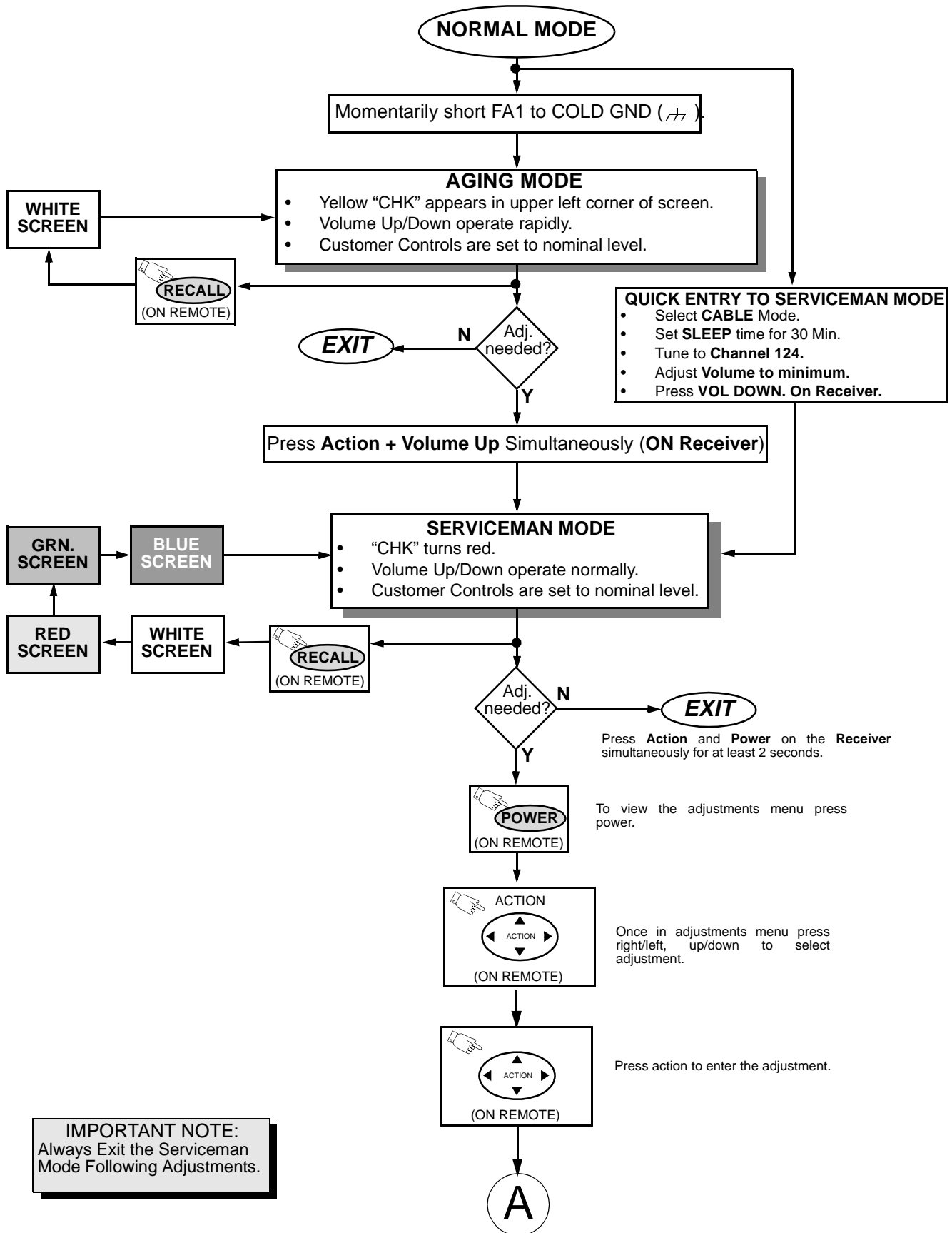

Figure 22.Flow Chart for Serviceman Mode.

Instructional Flow Chart for Serviceman Mode - Continued

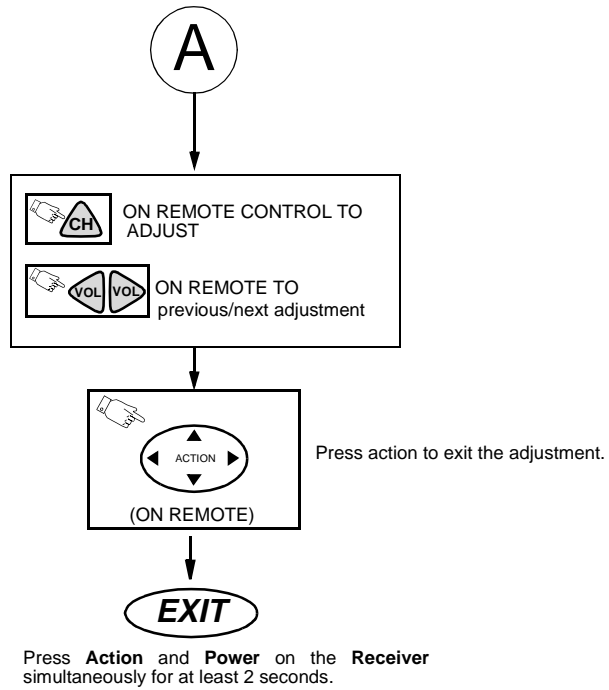

Figure 23. Flow Chart for Serviceman Mode (Continued).

Service Adjustments (Electronic Controls)

Sub-Brightness

Serviceman DAC Adjustment (BRIGHT)

Adjustment of this control is important for setting proper operation of customer brightness and picture controls. **Do not adjust** the SCREEN VR after the Sub-Brightness is set.

Preparation:

1. Normalize picture settings.
2. Switch NATURAL COLOR to OFF.
3. Switch COLOR TEMPERATURE to NORMAL.

Procedure:

1. Apply a black white cross pattern.
2. In the Serviceman Mode for making electronic adjustments, select the DAC adjustment (BRIGHT) and adjust data so that 7.5IRE part is the same light output as the 3IRE part.

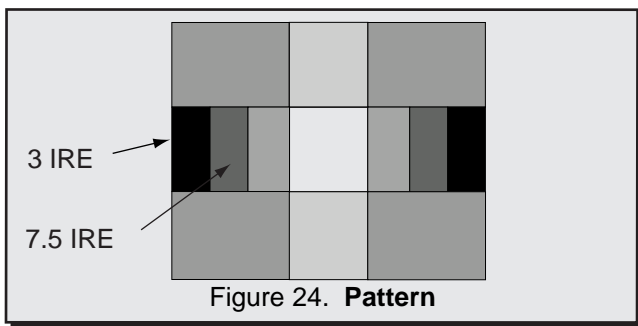

Sub-Contrast

Serviceman DAC Adjustment (BRIGHT, CONT)

This adjustment is factory set. **Do not adjust** unless repairs are made to associated circuit, the CRT Board or when the CRT is replaced.

Preparation:

1. Apply a Black-White pattern.
2. Set the picture settings to normal.
3. Connect the oscilloscope to TP47G.
4. Connect a jumper from A15-PIN(6) to cold ground (↗).

Procedure:

1. In the Serviceman Mode, select DAC for Green Cutoff Adjustment (CUT G) and set data to 2 80.
2. Set user color to minimum.
3. In Serviceman Mode, select DAC for Brightness adjustment (BRIGHT), and adjust data to obtain 2.6v between 7.5IRE and GND level at TP47G. (See waveform detail, Fig. 25)
4. In Serviceman Mode, select DAC for Contrast adjustment (CONT), and adjust data to obtain $3.3 \pm 0.1V$ between 7.5IRE and 100IRE level at TP47G. (See waveform detail, Fig. 25)
5. Set user color to normal.
6. Remove the jumper.

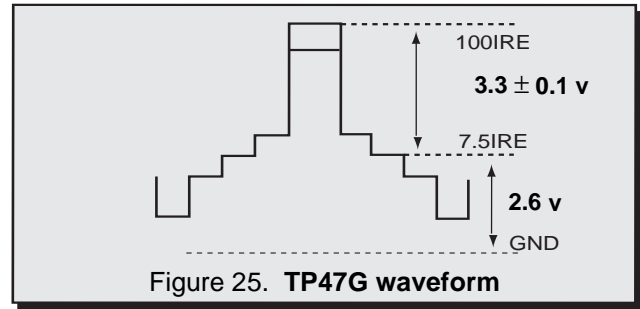

Color Output Adjustment

Serviceman DAC Adjustment (COLOR, TINT)

Make sure that Sub-Contrast adjustment was finished prior to do this adjustment

Preparation:

1. Normalize the picture settings.
2. Switch NATURAL COLOR to OFF.
3. Connect a jumper from A15 PIN(6) to cold ground (↗).

Procedure:

1. Apply a rainbow color bar pattern.
2. In Serviceman Mode adjust "R DR" and "B DR" data to "AF".
3. Connect the oscilloscope to TP47B.
4. In Serviceman Mode adjust "TINT" data so that the peak white is located at same level as peak "3", within $0 \pm 0.03V$. (See waveform detail, Fig. 26),

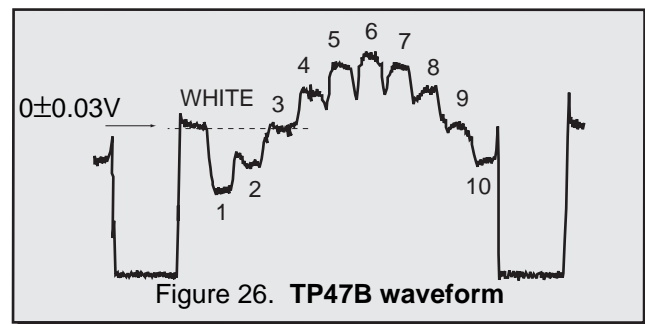

5. Connect the oscilloscope to TP47R.
6. In Serviceman Mode adjust "COLOR" data so that the amplitude "a" is $1.0 \pm 0.03V$. (See Fig. 27)

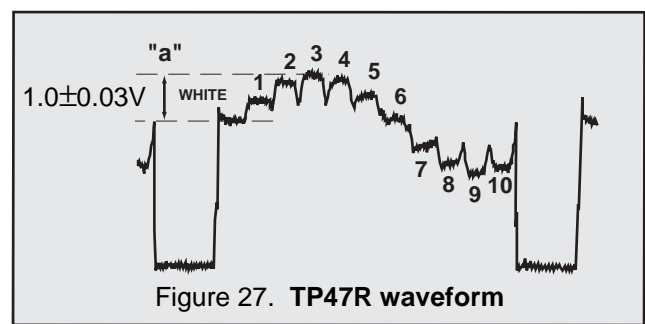

Service Adjustments (Electronic Controls, cont.)

7. Connect the oscilloscope to TP47B.
8. In Serviceman Mode adjust "B-Y G" data so that the amplitude "b" is $1.35 \pm 0.03V$. (See Fig. 28)

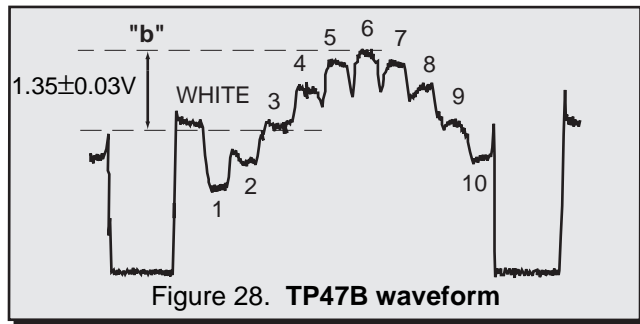

9. With oscilloscope still connected to TP47B, adjust "TINT" data so that the peak WHITE is located at same level as peak "3", within $0 \pm 0.03V$, then increase "TINT" data by 3 steps.
10. Connect oscilloscope to TP47G.
11. In Serviceman Mode adjust "COLOR" data so that the amplitude "c" is $1.4 \pm 0.03V$. (See Fig. 29).

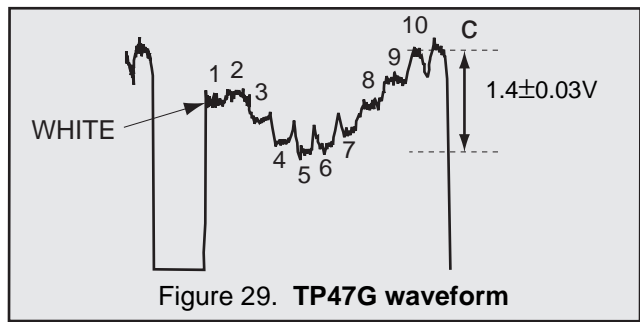

12. Apply a studio color bar pattern and confirm that saturation and phase are normal (normal image).

Color Temperature Adjustment (B/W Tracking)

Serviceman DAC Adjust. (CUT R) (CUT G) (CUT B) (R DR) (B DR)

Minor Touch-Up Method

OBSERVE low and high brightness areas of a B/W picture for proper tracking. Adjust only as required for "good gray scale and warm highlights".

1. LOW LIGHT areas – In Serviceman Mode for making electronic adjustments, select CUT R, CUT G, CUT B and adjust the picture for gray.
2. HIGH LIGHT areas – In Serviceman Mode for making electronic adjustments, select Drive R DR, B DR and adjust the picture for warm whites.

Complete Adjustment

Preparation:

1. Turn the Receiver "ON" and allow 30 minutes warm up at WHITE PATTERN.
2. Apply a white balance pattern.
3. Set Picture controls to Normalized.
4. Turn the SCREEN control (part of FBT T551) fully counterclockwise.

5. Preset the following Serviceman DACs for best results:
 - CUT R 0 00
 - CUT G 2 80
 - CUT B 0 00
 - R DR 40
 - B DR 40

Procedure:

1. Connect the oscilloscope to TP35 (CRT-Board).
2. In Serviceman Mode for making electronic adjustment, select "BRIGHT" DAC.
3. Press RECALL button on the Remote Control to collapse the raster. (Service SW).
4. Observe oscilloscope waveform and adjust serviceman mode "BRIGHT" DAC until $2.3V \pm 0.05V$ above DC ground is measured (See Fig. 30)

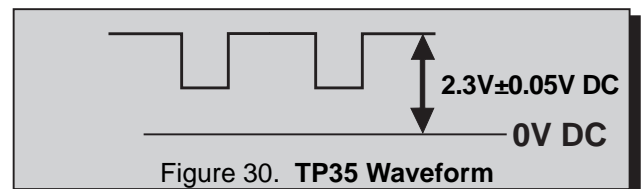

5. Press RECALL button on the Remote to restore the raster.
6. Connect scope to GRN Cathode (KG) on CRT-Board
7. In Serviceman mode for making electronic adjustments, select **CUT G** DAC.
8. Press RECALL button on the Remote to collapse the Raster (Service SW).
9. View scope trace at Horizontal rate and adjust Serviceman Mode "CUT G" DAC for the scanning period to be $170 \pm 2V$ above DC ground (See Fig. 31.)

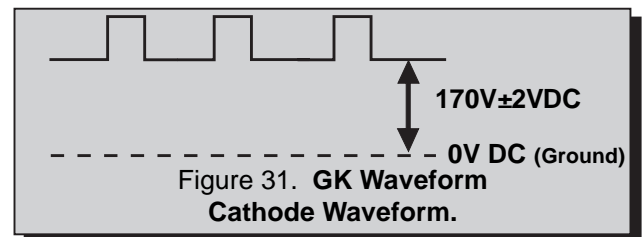

10. Remove the probe of the oscilloscope.
11. Turn SCREEN VR (Part of FBT) slowly clockwise until a faint green horizontal line appears.
12. Using the other two colors Serviceman Mode DAC CUT R and CUT B change their setting to produce a white horizontal line.
13. Press RECALL button on the Remote Control to restore full raster.
14. Confirm a good gray scale by viewing B/W color bar Pattern.
15. In serviceman Mode select DAC DRIVE adjustment "R DR" and "B DR" and adjust for warm white in white color bar of pattern.
16. If correction is needed perform **Minor Touch-Up Method**.

Service Adjustments (Electronic Controls, cont.)

Deflection Adjustments

Note: Deflection adjustment for RF, 1080i, 480p, dole window mode are provided differently.

H Center Adjustment

Preparation:

1. Apply a crosshatch pattern.

Procedure:

1. If horizontal linearity is poor, in Serviceman Mode, adjust data "H LIN" (See Fig. 32)

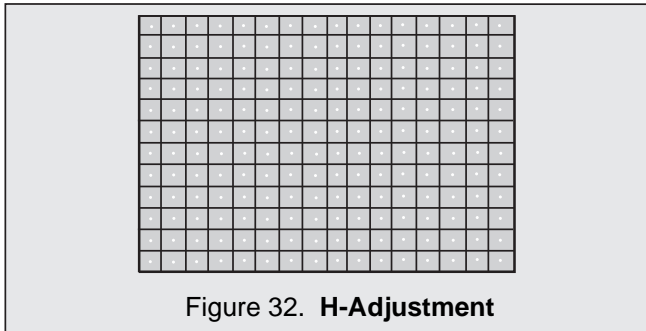

Figure 32. H-Adjustment

2. Apply a Monoscope pattern.
3. If the horizontal center is not aligned, in Serviceman Mode adjust "H POS" DATA to adjust the horizontal center of the monoscope pattern to the CRT center.

Vertical Linearity(V-C), V-Size and V-Position Adjustment

Preparation:

1. Apply a Crosshatch pattern

Procedure:

1. Enter Serviceman Mode, Select DAC adjustment "V RAS" and adjust crosshatch pattern to center vertical position to the CRT center.
2. Adjust linearity data "V-C" so that interval of "a" is same as "b" (a=b). (See Fig. 33)

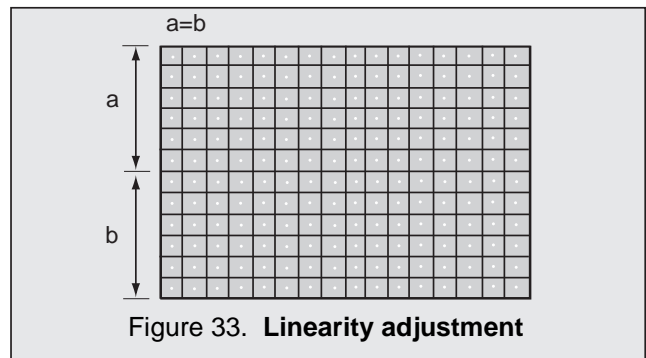

Figure 33. Linearity adjustment

3. If the v-position is not at the CRT center, adjust V position "V RAS" DATA again.

V-S, V-Size Adjustment

Preparation:

1. Apply a Crosshatch pattern.

Procedure:

1. Apply a crosshatch pattern.
2. Enter Serviceman Mode
3. Check a and b sizes, If $b-a < -1.5\text{mm}$ (in top & bottom extending case)
 - a. Increase "V-S" DATA by one step .
 - b. Adjust "VEAMP" so that V-SIZE is regular size again.

Note: Repeat "a" and "b" until $|b-a| \pm 1.5\text{mm}$

4. Check a and b sizes, If $b-a > -1.5\text{mm}$ (in top & bottom shortening case)
 - a. Decrease "V-S" by one step.
 - b. Adjust "VEAMP" so that V-Size is regular size again.

Note: Repeat "a" and "b" until $|b-a| \pm 1.5\text{mm}$

5. Confirm to make outermost circle of monoscope pattern a correct circle.

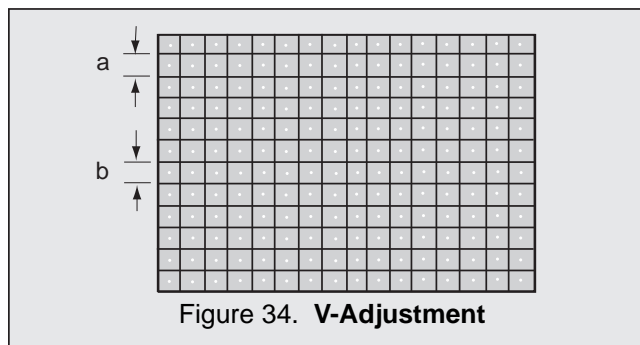

Figure 34. V-Adjustment

Trapezoid, Parallelogram and E-W PCC Adjustment

Trapezoid Adjustment

Preparation:

1. Apply a Crosshatch pattern
2. Normalize the Picture Icon Video adjustments.

Procedure:

1. Enter Serviceman Mode, select "TRAP" and Adjust DATA so that lines at right and left are vertical like a solid line (See Fig. 35)

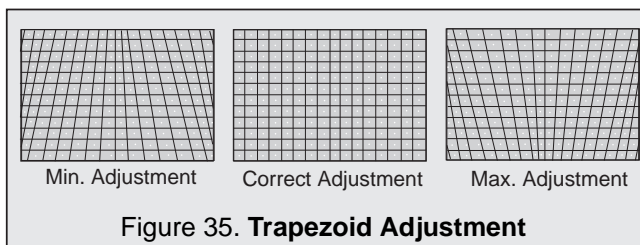

Figure 35. Trapezoid Adjustment

Parallelogram Adjustment

Preparation:

1. Apply a Crosshatch pattern
2. Normalize the Picture Icon Video adjustments.

Procedure:

1. Enter Serviceman Mode, select "PARA" and adjust so that the lines at right and left are vertical like solid line. (See Fig. 36)

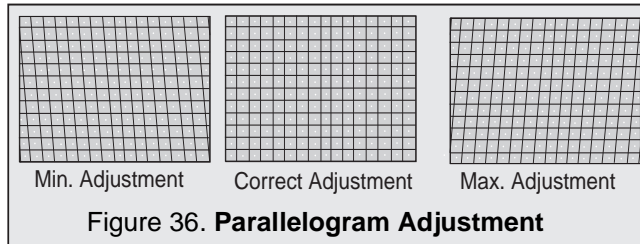

Figure 36. Parallelogram Adjustment

E-W PCC Balance Adjustment

Preparation:

1. Apply a Crosshatch pattern
2. Normalize the Picture Icon Video adjustments.

Procedure:

1. Enter Serviceman Mode, select "SIDE" and adjust so that lines at right and left are vertical like solid line. (See Fig. 37)

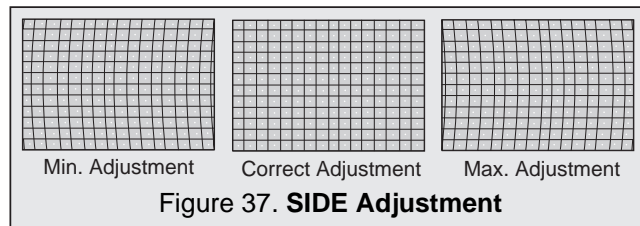

Figure 37. SIDE Adjustment

E-W PCC Adjustment

Preparation:

1. Apply a Crosshatch pattern
2. Normalize the Picture Icon Video adjustments.

Procedure:

1. Confirm that trapezoid adjustment is done.
2. Adjust "PCC" DATA so that the 1st line and 3rd line make a good balance (See Fig. 38).

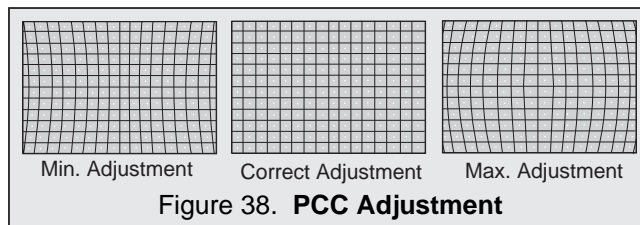

Figure 38. PCC Adjustment

Note: If side and lower side is imbalanced, adjust "PCCHG" and "PCCLG" so that "PCC" make good balance.

Corner PCC Adjustment

Preparation:

1. Apply a Crosshatch pattern
2. Normalize the Picture Icon Video adjustments.

Procedure:

1. To adjust upper and lower linearity.
2. Adjust "TOPG" to straighten upper lines (See Fig. 39)

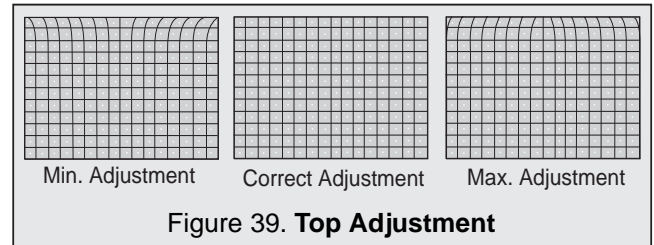

Figure 39. Top Adjustment

3. Adjust "BTMG" to straighten lower lines (See Fig. 40)

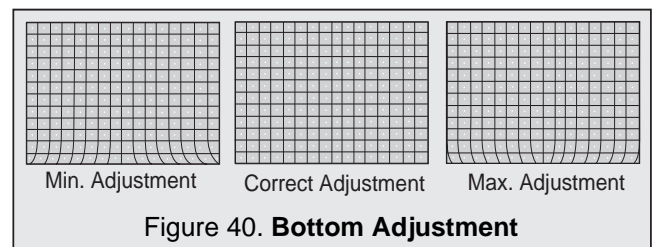

Figure 40. Bottom Adjustment

Note: If TOP-BOTTOM bending point is not so good, adjust "TOPSL" and "BTMSL" of slice level.

H-Size Adjustment

Preparation:

1. Apply a Monoscope pattern

Procedure:

1. Adjust "H WID" DATA so that width "A" and "B" becomes 5.00 ± 0.40 (when using factory pattern) (See Fig. 41).

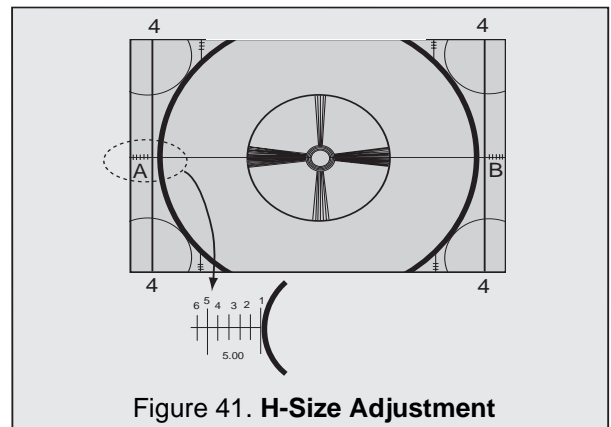

Figure 41. H-Size Adjustment

Note: When using a different pattern, correlate with factory pattern.

Service Adjustments (Electronic Controls, cont.)

MTS Circuit Adjustments

The MTS Circuit Adjustments require two steps:

1. Input Level Adjustment.
2. Stereo Separation Adjustment.

Input Level Adjustment

Serviceman DAC Adjustment (MTSIN)

Preparation:

1. Connect an RMS meter with filter jig as shown in Fig. 42.

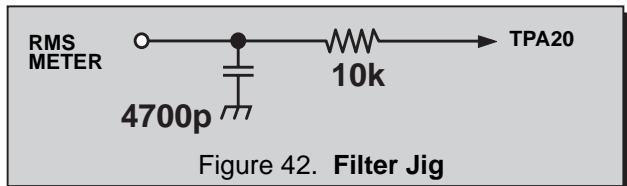

2. Connect an RF signal generator to the RF antenna input.

Procedure:

1. Apply the following signal from the RF signal generator:
Video: 100 IRE flat field, 30% modulation.
Audio: 300Hz, 100% modulation, monaural (70 ±5dB, 75Ω OPEN, P/S 10dB). Make sure that the 75μs pre-emphasis is OFF.
2. Adjust the **MTS Input** Level Adjustment (**MTSIN**) data until the RMS voltage measured is **490 ± 20mVrms**.

Stereo Separation Adjustment (SEPAH)

Preparation:

1. Connect an RF signal generator to the RF antenna input.
2. Connect a scope to TPA19.

Procedure:

1. Select Stereo Mode in Audio menu
2. Apply the following signal from the RF signal generator:
Video: 100 IRE flat field, 30% modulation.
Audio: 300Hz, 30% modulation, stereo (left only) (70±5dB, 75Ω OPEN, P/S 10dB).

Note: After setting 30% modulation with P.L. SW and N.R. SW OFF, turn P.L. SW and N.R. SW ON.

3. In Serviceman Mode, Adjust the MTS Low-Level Separation Adjustment (SEPAL) data until the amplitude displayed on the scope is minimum.
4. Apply the following signal from the RF signal generator:
Video: 100 IRE flat field, 30% modulation.
Audio: 3KHz, 30% modulation, stereo (left only) (70 ±5dB, 75Ω OPEN, P/S 10dB).

Note: After setting 30% modulation with P.L. SW and N.R. SW OFF, turn P.L. SW and N.R. SW ON.

5. Adjust the MTS High-level Separation Adjustment (SEPAH) until the amplitude displayed on the scope is minimum.
6. Repeat above steps 2 through 4 until the amplitude is at minimum for both signals.

Service Adjustments (Electronic Controls, cont.)

Sub Picture YUV output adjustment

Preparation:

1. Apply a studio color bar pattern.
2. Connect the oscilloscope to TP223(Y).

Procedure:

1. Push "SPLIT/SIZE" key on the remote control.
2. In Serviceman Mode adjust "Y DRV" data so that the amplitude "b" is same level as "a", within $0 \pm 0.03V$. (See Fig. 43).

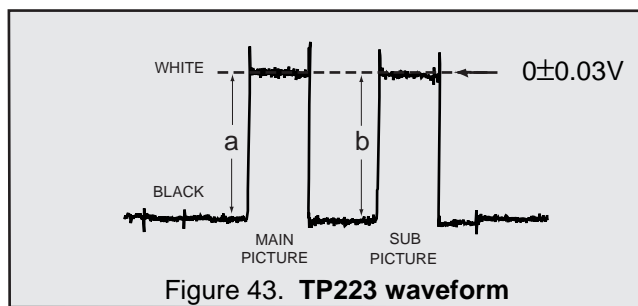

3. Connect the oscilloscope to TP222(PB).
4. In Serviceman Mode, adjust "UVDRV" data so that the amplitude "d" is same level as "c", within $0 \pm 0.03V$. (See Fig. 44)

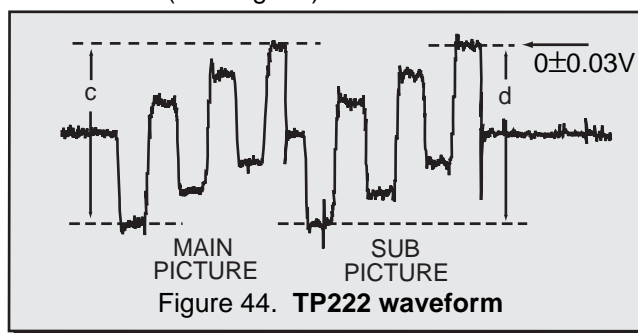

Clock Adjustment (CLOCK)

Preparation:

Connect the frequency counter from TPA11 (IC001 Pin 50) to cold ground (↗).

Note: Frequency Counter probe capacitance should be 8pF or less.

Procedure:

1. Turn the Receiver "OFF" with the AC power applied.
2. Measure TPA11 (IC001 pin 50) for the frequency of the waveform and record the reading.

Note: Pin 50 measurement must have at least four digits of resolution following the decimal point. Example: 000.0000

3. Turn the Receiver back "ON".
4. Place the Receiver into Serviceman Mode for making electronic adjustment, select the Clock Adjustment DAC (CLOCK).
5. Calculate and set "CLOCK" based on the following formula:

$$CLOCK = 128 + (0.450) \times 10^6 \frac{\{(732.4220) - pin50[Hz]\}}{(732.4220)}$$

Note: Pin 50 measurement will not change regardless of the value stored in CLOCK.

Service Adjustments (Mechanical Controls)

Width Correction Adjustment

Note: Perform this adjustment only when FBT is changed.

Preparation:

Connect the DVM (Digital Voltage Meter) (+) lead to connector Q10 PIN-10 or TPQ27; and (-) lead to connector Q10 PIN-3.

Procedure:

1. Apply a Black pattern.

Adjust R524 so that the voltage on Connector Q10 Pin-10 or TPQ27 is $1.8 \pm 0.1V$ on D-Board.

Focus (part of T551)

Preparation:

Connect a Signal generator and select a dot pattern.

Procedure:

1. Adjust the FOCUS control to obtain the sharpest and clearest dot pattern.
 - a. Adjust for best center.
 - b. Adjust for best area between the center and top right corner.

Video-Chroma Signal Path Block Diagram

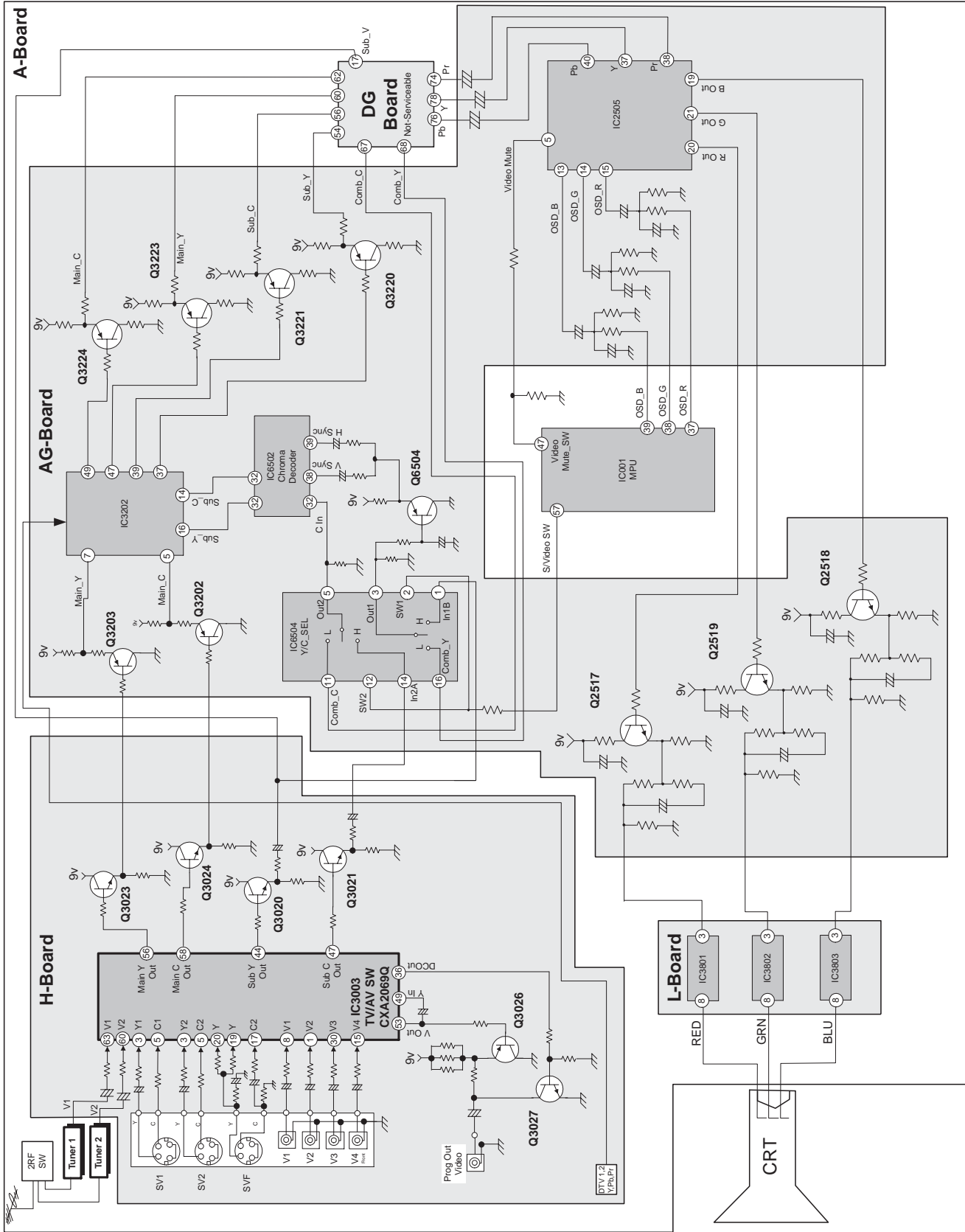

Figure 46. Video-Chroma Signal Path Block Diagram.

IIC Connection

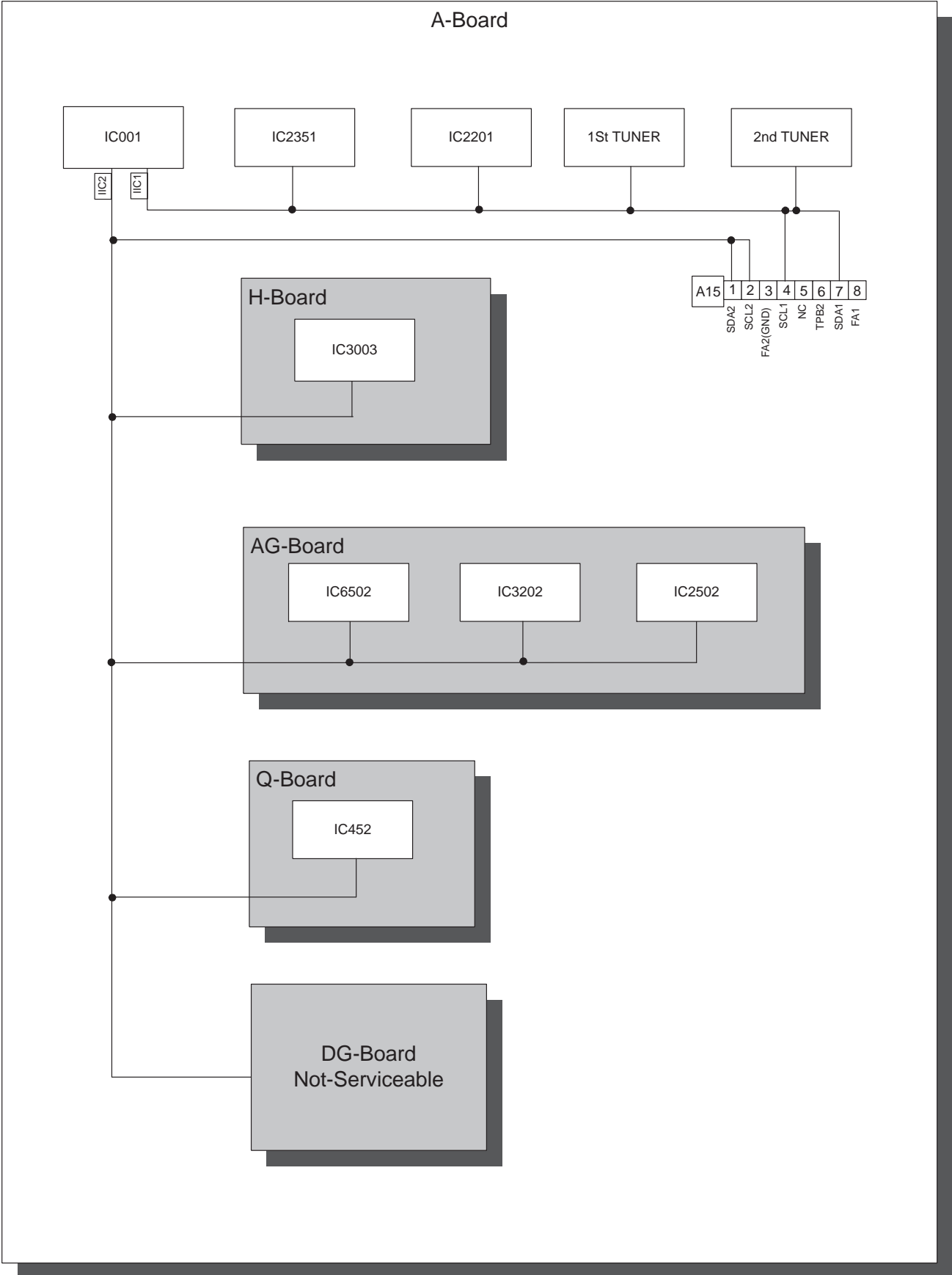

Figure 47. IIC Connection

IC001 IN/OUT Pins and Functions (MPU)

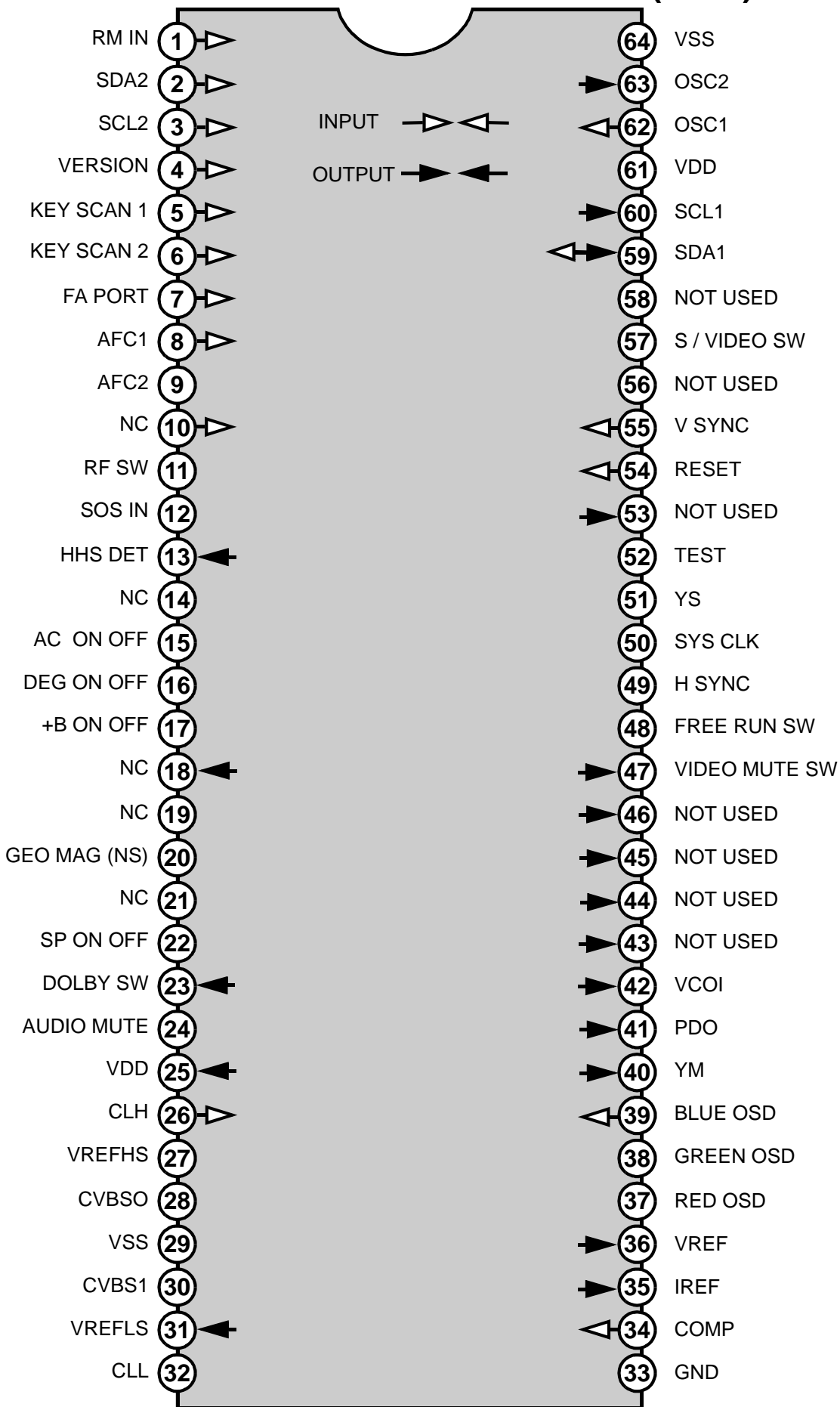
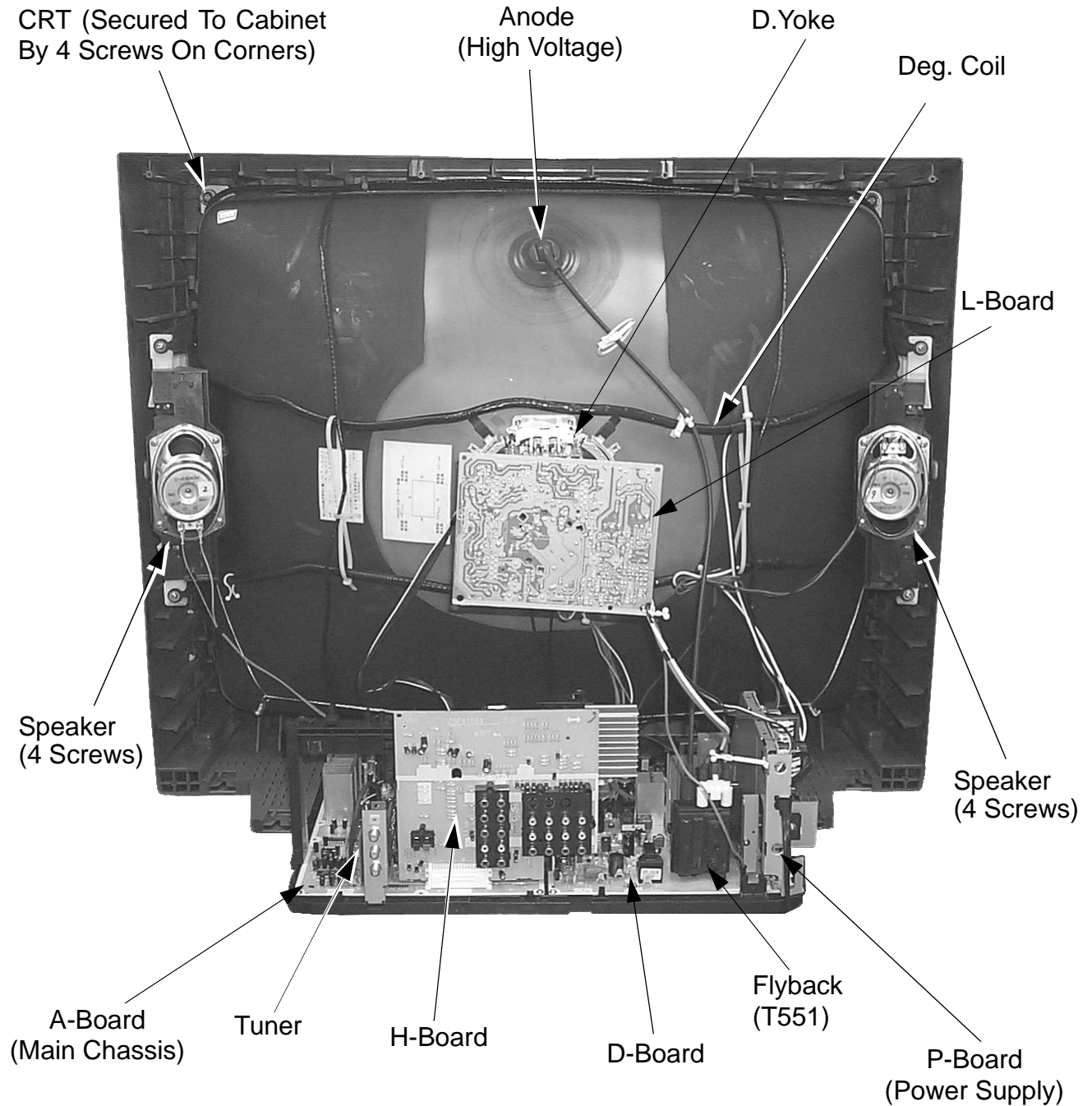

Figure 48. MPU IN/OUT Pins and Functions.

Identification of Components



Note: After servicing the receiver, remember to dress the cables, as shown above.

Figure 49. Rear View.

Identification of Components

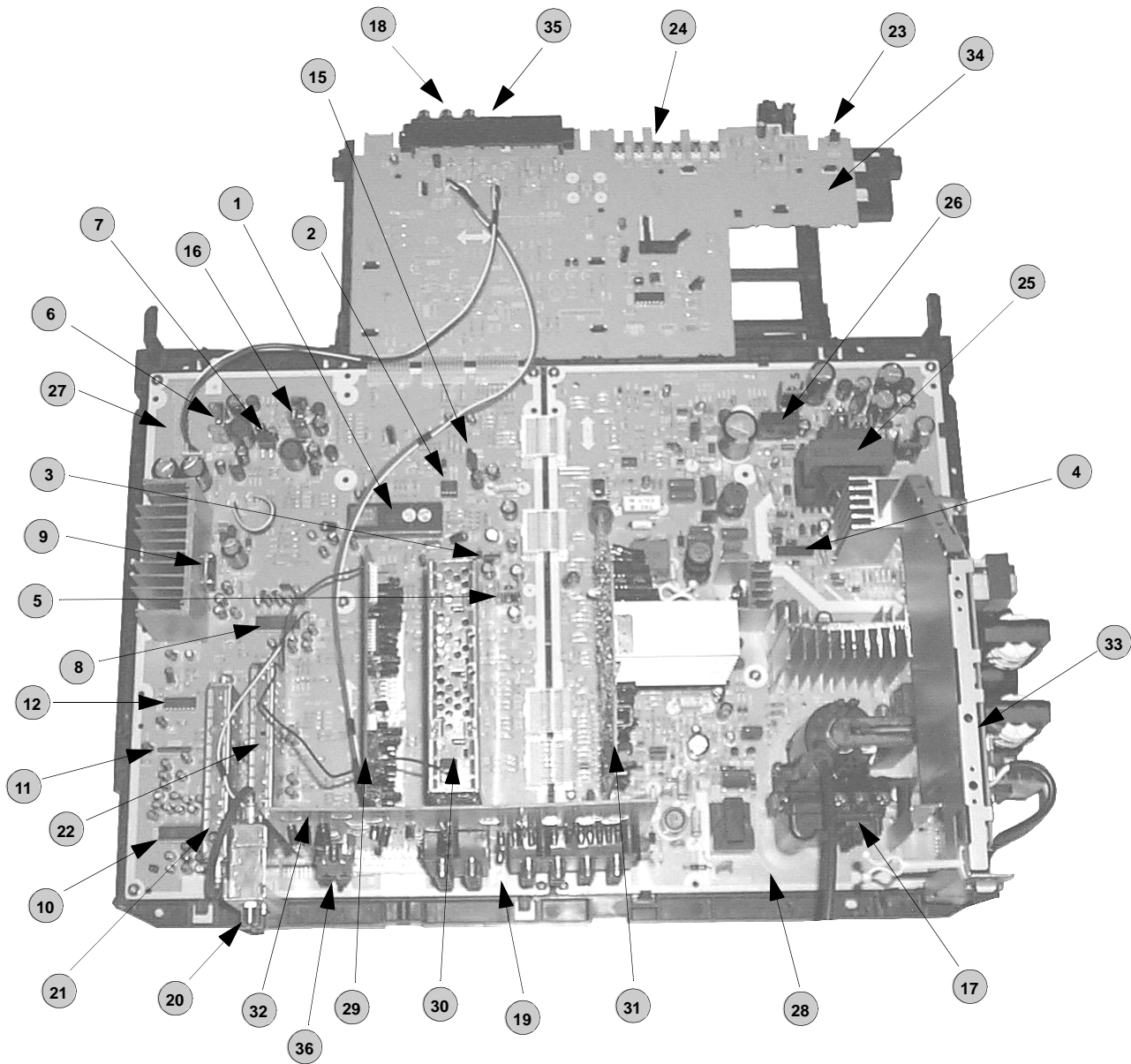

Figure 50. View of Main Board Assemblies.

NO.	LOCATION OF COMPONENTS						
INTEGRATED CIRCUITS		9	IC2301 L/R AMP	19	BACK A/V INPUTS	28	D-BOARD
1	IC001 MPU	10	IC2351 SPAT, AGC AUDIO CONT	20	ANTENNA JACKS	29	AG-BOARD
2	IC002 EE PROM	11	IC2352 VAO AMP	21	TUNER 1	30	DG-BOARD
3	IC003 STB_3.3V	12	IC2353 DOLBY CENT. SW	22	TUNER 2	31	Q-BOARD
4	IC801 MAIN_POWER_IC	15	IC880 GC_3.3V	23	IR SENSOR	32	H-BOARD
5	IC872 D_3.3V	16	IC871 5V	24	KEYBOARD	33	P-BOARD
6	IC875 9V	OTHERS		25	T801	34	G-BOARD
7	IC876 12V	17	FLYBACK	26	RL804	35	FRONT S-VIDEO INPUT
8	IC2201 MTS	18	FRONT A/V INPUTS	27	A-BOARD	36	DOLBY CENTER IN

Identification of Components (Cont....)

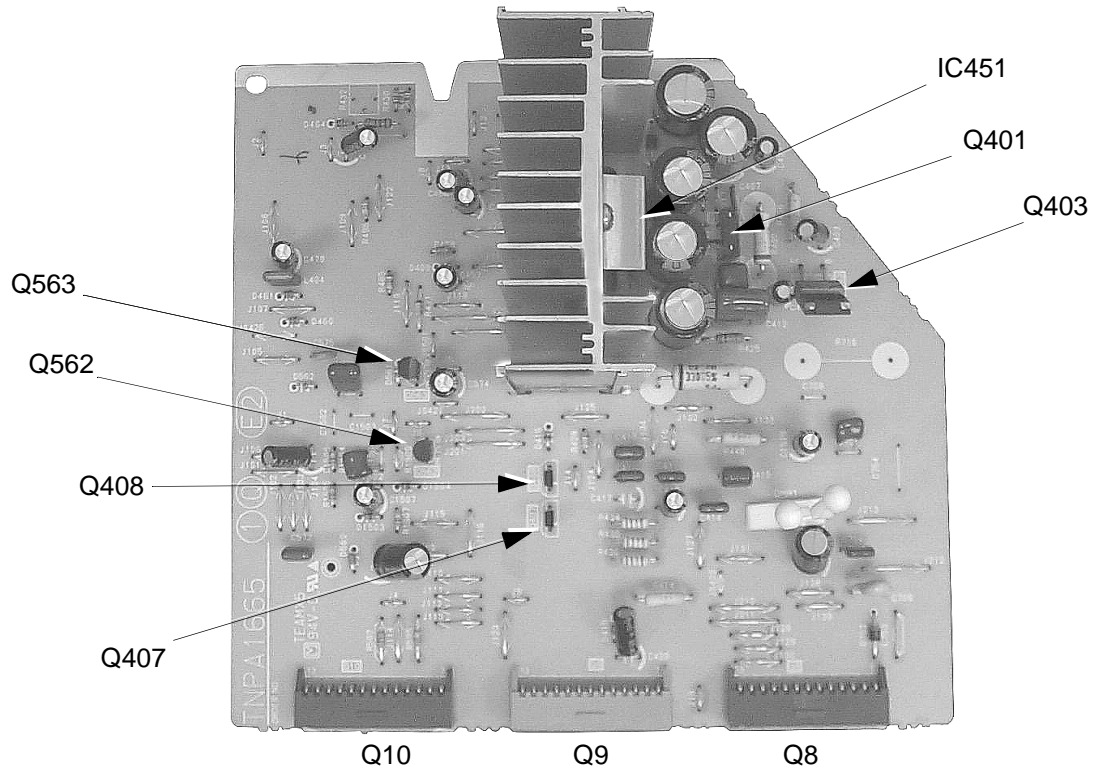

Figure 51. Q-Board

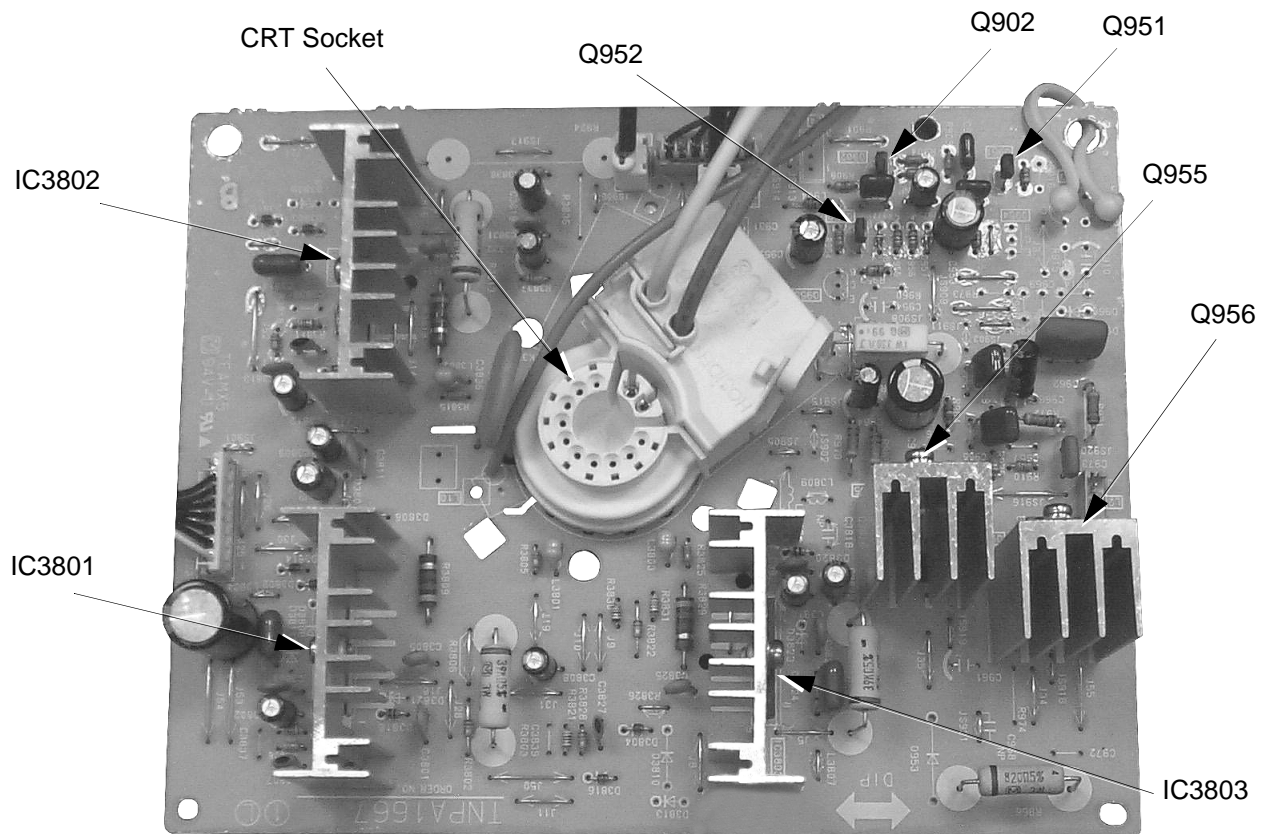

Figure 52. L-Board

Identification of Components (Cont....)

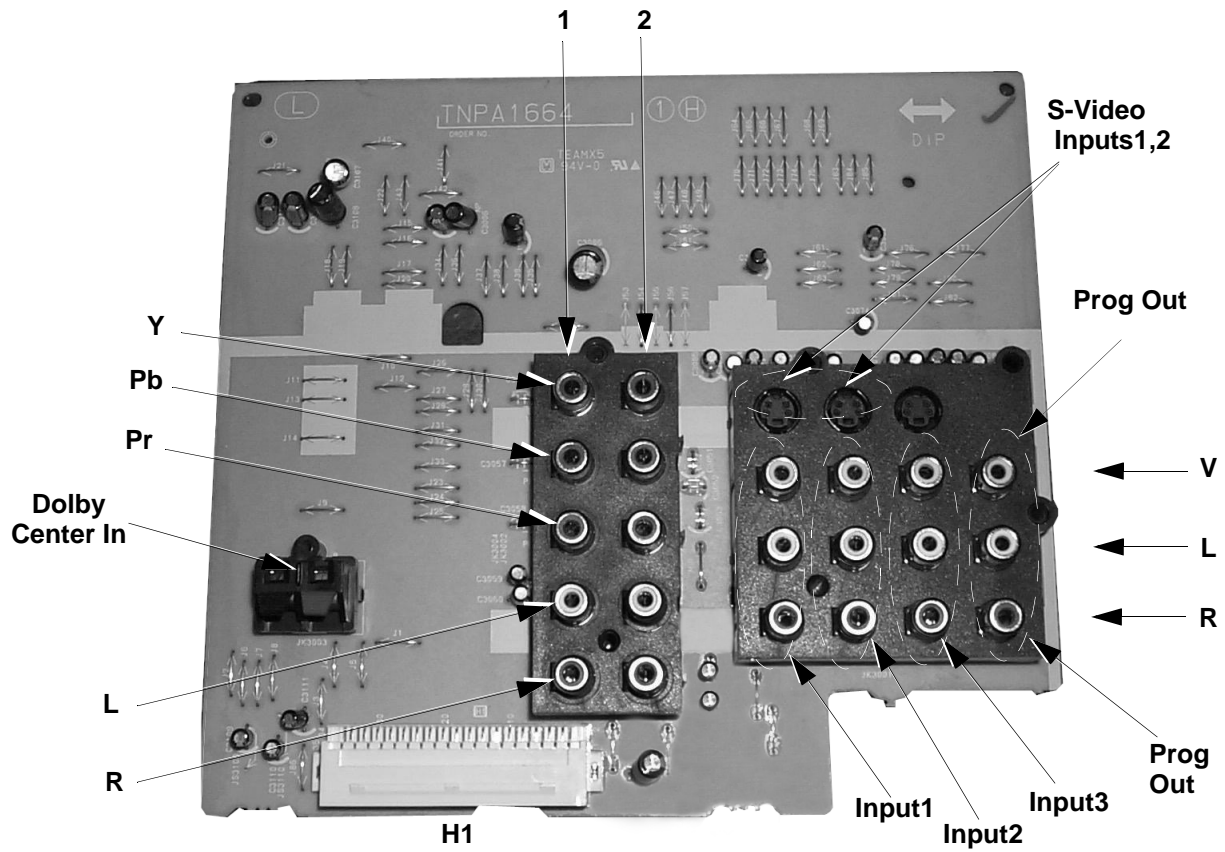

Figure 53. H-Board

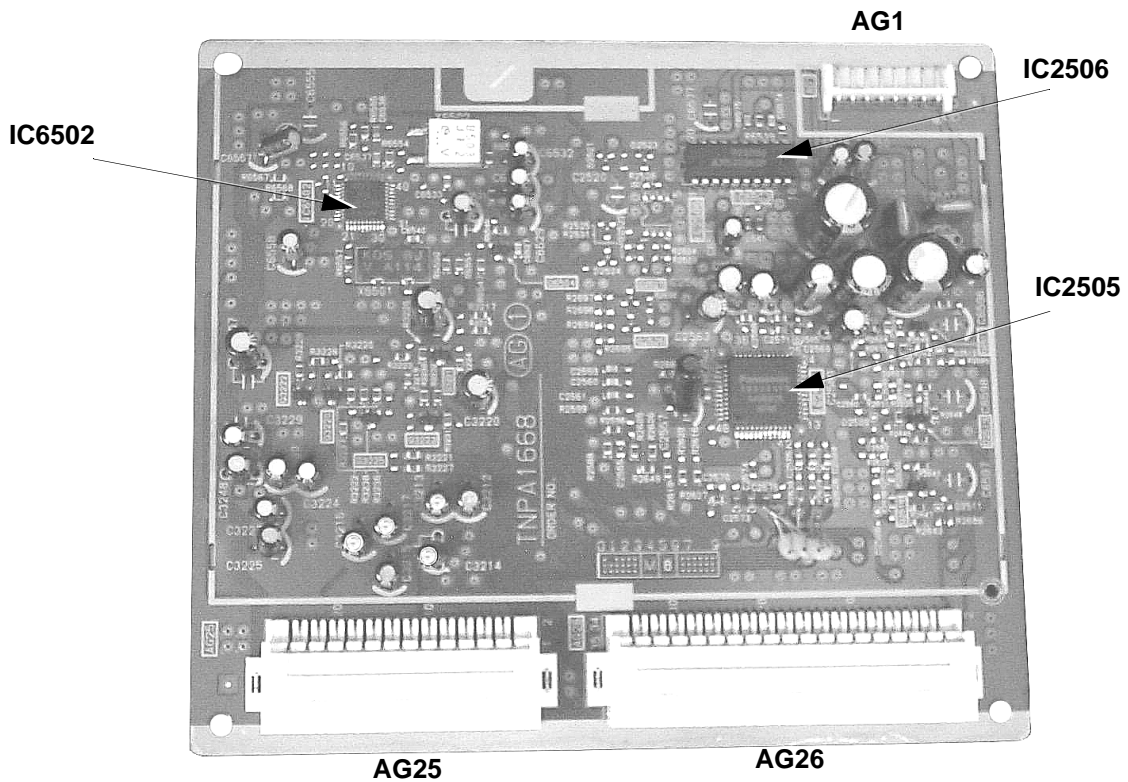

Figure 54. AG-Board

REPLACEMENT PARTS LIST

Models: CT-32HX40B/CB & CT-36HX40B/CB

Important Safety Notice: Components printed in **BOLD TYPE** have special characteristics important for safety. When replacing any of these components use only manufacturer's specified parts.

REF NO.	PART NO.	DESCRIPTION	REF NO.	PART NO.	DESCRIPTION
CAPRISTORS			C403	ECA1VM470	CAP,E 47UF/35V
CRA801	EXNG131P365	RES-CAP 130PF/3.6 MEG	C404	ECA1EM222	CAP,E 2200UF-25V
CRA803	EXNG131P365	RES-CAP 130PF/3.6 MEG	C405	ECA1HM102	CAP,E 1000UF/50V
CAPACITORS			C406	ECQV1H105JL	CAP,P 1.0UF-J-50V
C001	ECJ2VC1H101J	CAP,C 100PF-J-50V	C407	ECKF1H103ZF	CAP,C .01UF-Z-50V
C004	ECJ2VF1H103Z	CAP,C .01UF-Z-50V	C408	ECA1VM102	CAP,E 1000UF/35V
C005	ECJ2VF1H103Z	CAP,C .01UF-Z-50V	C409	ECA1VM102	CAP,E 1000UF/35V
C010	ECJ2VC1H101J	CAP,C 100PF-J-50V	C411	ECQB1H472JF	CAP,P .0047UF-J-50V
C011	ECA1HM220	CAP,E 22UF/50V	C412	ECQB1224KF	CAP,P .22UF-K-100V
C012	ECA1HM010	CAP,E 1.0UF/50V	C413	ECA1HM010	CAP,E 1.0UF/50V
C013	ECEA1CN470U	CAP,E 47UF-16V	C414	ECQB1H272JF	CAP,P .0027UF-J-50V
C014	ECEA1CN470U	CAP,E 47UF-16V	C415	ECQB1473KF	CAP,P .047UF-K-100V
C015	ECA1HM010	CAP,E 1.0UF/50V	C416	ECQB1H472JF	CAP,P .0047UF-J-50V
C016	ECA1HM010	CAP,E 1.0UF/50V	C418	ECQB1H473JF	CAP,P .047UF-J-50V
C017	ECJ2VF1H103Z	CAP,C .01UF-Z-50V	C419	EEUNA1A470B	CAP,E 47UF-125V
C018	ECJ2VB1H392K	CAP,C .0039UF-K-50V	C420	ECA1CM101	CAP,E 100UF/16V
C019	ECA1HM010	CAP,E 1.0UF/50V	C422	ECA1HM010	CAP,E 1.0UF/50V
C020	ECJ2VC1H101J	CAP,C 100PF-J-50V	C451	ECJ2VF1H102Z	CAP,C .001UF-Z-50V
C021	ECJ2VC1H101J	CAP,C 100PF-J-50V	C457	ECEA1CN220U	CAP,E 22UF-16V
C022	ECJ2VC1H200J	CAP,C 20PF-J-50V	C466	ECA1HM100	CAP,E 10UF/50V
C023	ECJ2VC1H200J	CAP,C 20PF-J-50V	C477	ECJ2VF1H103Z	CAP,C .01UF-Z-50V
C024	ECA0JM102	CAP,E 1000UF/6.3V	C478	ECA1HM100	CAP,E 10UF/50V
C026	ECJ2VF1H103Z	CAP,C .01UF-Z-50V	C479	ECA1HM100	CAP,E 10UF/50V
C027	ECA1CM471	CAP,E 470UF/16V	C501	ECA1VM101	CAP,E 100UF/35V
C028	ECJ2VF1H103Z	CAP,C .01UF-Z-50V	C502	ECQV1H104JL	CAP,P .10UF-J-50V
C029	ECA1CM471	CAP,E 470UF/16V	C503	ECKD2H102KB	CAP,C .001UF-K-500V
C030	ECA1HM100	CAP,E 10UF/50V	C506	ECA1CM471	CAP,E 470UF/16V
C031	ECA1CM101	CAP,E 100UF/16V	C509	ECKD3A222KB	CAP,C .0022UF-K-1KV
C033	ECJ2VF1H104Z	CAP,C .1UF-Z-50V	C511	ECWH20332JVY	CAP,P 3300PF-J-2KV
C036	ECJ2VF1H104Z	CAP,C .1UF-Z-50V	C513	ECQF6103JZH	CAP,P .010UF-J-630V
C037	ECJ2VF1H103Z	CAP,C .01UF-Z-50V	C514	ECWH20362JVY	CAP,P 3600PF-J-2KV
C038	EEUFC1A471B	CAP,E 470UF-10V	C515	ECKD3A222KB	CAP,C .0022UF-K-1KV
C039	ECA1HM4R7	CAP,E 4.7UF/50V	C516	ECWF2224JSR	CAP,M .22UF-J-200V
C040	ECA1CM470	CAP,E 47UF/16V	C517	ECWF2684JSR	CAP,M .26UF-J-200V
C041	ECA1HM2R2	CAP,E 2.2UF/50V	C518	ECKD3D681KB	CAP,C 680PF-K-2KV
C042	ECA1VM470	CAP,E 47UF/35V	C519	ECKD3D681KB	CAP,C 680PF-K-2KV
C043	ECA1HM4R7	CAP,E 4.7UF/50V	C520	ECQB1H183JF	CAP,P .018UF-J-50V
C044	ECA1CM470	CAP,E 47UF/16V	C521	ECWF2224JSR	CAP,M .22UF-J-200V
C045	ECA1HM2R2	CAP,E 2.2UF/50V	C522	ECWH20202JVY	CAP,P 2000PF-J-2KV
C047	ECA1HM010	CAP,E 1.0UF/50V	C523	ECWH20242JVY	CAP,P 2400PF-J-2KV
C050	ECJ2VC1H471J	CAP,C 470PF-J-50V	C524	ECQB1224JF	CAP,P .22UF-J-100V
C051	ECJ2VC1H561J	CAP,C 560PF-J-50V	C525	EEUNA1E220B	CAP,E 22UF-25V
C052	ECEA1HN010U	CAP,E 1UF/50V	C526	ECA2EM470	CAP,E 47UF-250V
C053	ECJ2VC1H471J	CAP,C 470PF-J-50V	C527	ECKD2H102KB	CAP,C .001UF-K-500V
C054	ECJ2VC1H561J	CAP,C 560PF-J-50V	C528	ECA1HM4R7	CAP,E 4.7UF/50V
C055	ECEA1HN010U	CAP,E 1UF/50V	C530	ECQE2155JF	CAP,P 1.5UF-J-200V
C056	ECJ2VF1H103Z	CAP,C .01UF-Z-50V	C531	ECA160V33UE	CAP,E 33UF/160V
C058	ECA1HMR22	CAP,E .22UF/50V	C532	ECQF6332JZH	CAP,P .033UF-J-630V
C059	ECA1HMR22	CAP,E .22UF/50V	C535	ECA1HM471	CAP,E 470UF/50V
C401	ECA1EHG470B	CAP,E 47UF-25V	C536	ECEA1HN100U	CAP,E 10UF/50V
C402	ECA1EM222	CAP,E 2200UF-25V	C537	ECQB1H473JF	CAP,P .047UF-J-50V

REPLACEMENT PARTS LIST

Models: CT-32HX40B/CB & CT-36HX40B/CB

Important Safety Notice: Components printed in **BOLD TYPE** have special characteristics important for safety. When replacing any of these components use only manufacturer's specified parts.

REF NO.	PART NO.	DESCRIPTION
C538	ECA1CM471	CAP,E 470UF/16V
C539	ECA1CM471	CAP,E 470UF/16V
C541	ECQE2333JF	CAP,P .033UF-J-200V
C570	ECA1CM471	CAP,E 470UF/16V
C571	ECJ2VF1H103Z	CAP,C .01UF-Z-50V
C572	ECHS1H102FZ3	CAP,P 1000PF-J-50V
C573	ECQB1H104JF	CAP,P .1UF-J-50V
C574	ECA1HM470	CAP,E 47UF/50V
C575	ECKF1H103ZF	CAP,C .01UF-Z-50V
C576	ECJ2VC1H220J	CAP,C 22PF-J-50V
C580	ECQV1H334JL	CAP,P .33UF-J-50V
C701	ECQB1H182JF	CAP,P .0018UF-J-50V
C704	ECQB1H152JF	CAP,P .0015UF-J-50V
C705	ECJ2VC1H221J	CAP,C 220PF-J-50V
C706	ECKD3D271JB	CAP,C 270PF-J-2KV
C709	ECQE1335KF	CAP,P 3.3UF-K-100V
C710	ECQE1335KF	CAP,P 3.3UF-K-100V
C711	ECQE1335KF	CAP,P 3.3UF-K-100V
C712	ECKF1H221KB	CAP,C 220PF-K-50V
C713	ECKF1H221KB	CAP,C 220PF-K-50V
C714	ECA1HM2R2	CAP,E 2.2UF/50V
C759	ECQM2104KZ	CAP,P .1UF-K-200V
C801	ECQU2A104MN	CAP,P .01UF-M-250VAC
C802	ECQU2A823MN	CAP,P .082UF-M-250VAC
C803	ECQB1H222JF	CAP,P .0022UF-J-50V
C804	EC0S2DA821DB	CAP,E 820UF-200V
C805	ECKD2H472PU	CAP,C .0047UF-P-500V
C806	ECKD2H472PU	CAP,C .0047UF-P-500V
C807	ECKD2H472PU	CAP,C .0047UF-P-500V
C808	ECQB1H102JF	CAP,P .001UF-J-50V
C809	ECQB1H333JF	CAP,P .033UF-J-50V
C811	EC0S2DA821DB	CAP,E 820UF-200V
C812	ECA1EM471	CAP,E 470UF/25V
C813	ECA1HM010	CAP,E 1.0UF/50V
C815	ECA1EM471	CAP,E 470UF/25V
C816	ECKD3A102KB	CAP,C .001UF-K-1KV
C817	ECQB1H332JF	CAP,P .0033UF-J-50V
C819	TACCQ221T50V	CAP,C 220PF/50V
C820	ECA1EHG471B	CAP,E 470UF-25V
C821	ECKD3D222KB	CAP,C .0022UF-K-2KV
C822	ECQB1H393JF	CAP,P .039UF-J-50V
C826	ECA1VM221	CAP,E 220UF/35V
C827	ECQB1H333JF	CAP,P .033UF-J-50V
C830	EETHC2C102H	CAP,E 1000UF-160V
C831	ECKD3A102KB	CAP,C .001UF-K-1KV
C832	ECA1HHG101B	CAP,E 100UF-50V
C833	ECKD3A471KB	CAP,C 470PF-K-1KV
C834	EEUFC1V222E	CAP,E 2200UF-35V
C836	ECKD3A331KB	CAP,C 330PF-K-1KVDC
C837	EEUFC1E272E	CAP,E 2700UF-25V
C838	EEUFC1E272E	CAP,E 2700UF-25V

REF NO.	PART NO.	DESCRIPTION
C839	ECKD3A151KB	CAP,C 150PF-K-1KV
C840	ECA1EMH471B	CAP,E 470UF-25V
C841	ECA1EHG102E	CAP,E 1000UF-25V
C842	ECKD3A331KB	CAP,C 330PF-K-1KVDC
C843	ECA1HHG102E	CAP,E 1000UF-50V
C844	ECKD3A471KB	CAP,C 470PF-K-1KV
C845	ECA1CM101	CAP,E 100UF/16V
C846	ECA1HM010	CAP,E 1.0UF/50V
C847	ECA1VM470	CAP,E 47UF/35V
C848	ECA1CM101	CAP,E 100UF/16V
C852	ECKCNB472ME	CAP,C 4700PF-M-250V
C853	ECKCNB472ME	CAP,C 4700PF-M-250V
C856	ECQU2A103MN	CAP,P .010UF-M-250V
C857	ECA1CM101	CAP,E 100UF/16V
C873	ECA1CM471	CAP,E 470UF/16V
C874	ECA1CM471	CAP,E 470UF/16V
C876	ECA1EM471	CAP,E 470UF/25V
C877	EEUFC1A471B	CAP,E 470UF-10V
C878	ECA1CM471	CAP,E 470UF/16V
C879	ECA1CM471	CAP,E 470UF/16V
C880	ECJ2VF1H103Z	CAP,C .01UF-Z-50V
C881	ECJ2VF1H103Z	CAP,C .01UF-Z-50V
C882	ECJ2VF1H103Z	CAP,C .01UF-Z-50V
C885	ECA1VM471	CAP,E 470UF/35V
C886	EEUFC1C471B	CAP,E 470UF-16V
C888	ECA1VM101	CAP,E 100UF/35V
C889	ECA1VM101	CAP,E 100UF/35V
C890	ECA1CM221	CAP,E 220UF/16V
C891	ECJ2VF1H103Z	CAP,C .01UF-Z-50V
C892	ECA1CM221	CAP,E 220UF/16V
C893	ECJ2VF1H103Z	CAP,C .01UF-Z-50V
C894	ECA1VM101	CAP,E 100UF/35V
C897	ECA1EM471	CAP,E 470UF/25V
C898	ECJ2VB1H103K	CAP,C .01UF-K-50V
C899	ECJ2VB1H103K	CAP,C .01UF-K-50V
C901	ECQB1H103JF	CAP,P .01UF-J-50V
C906	ECEA1CN100U	CAP,E 10UF-16V
C952	ECA1CM221	CAP,E 220UF/16V
C953	ECA1CM471	CAP,E 470UF/16V
C955	ECQB1223KF	CAP,P .22UF-K-100V
C959	ECQB1223KF	CAP,P .22UF-K-100V
C962	ECQM4103KZ	CAP,P .01UF-K-400V
C964	ECA1CM101	CAP,E 100UF/16V
C966	ECA1CM101	CAP,E 100UF/16V
C967	ECA2CHG330E	CAP,E 33UF-160V
C970	ECQB1H103JF	CAP,P .01UF-J-50V
C971	ECQB1H103JF	CAP,P .01UF-J-50V
C973	ECQM2102KZ	CAP,P .10F-K-200V
C1051	TACCX103T50V	CAP,C .01UF/50V
C1052	ECA1HM470	CAP,E 47UF/50V
C1063	ECCF1H101JC	CAP,C 100PF-J-50V

REPLACEMENT PARTS LIST

Models: CT-32HX40B/CB & CT-36HX40B/CB

Important Safety Notice: Components printed in **BOLD TYPE** have special characteristics important for safety. When replacing any of these components use only manufacturer's specified parts.

REF NO.	PART NO.	DESCRIPTION	REF NO.	PART NO.	DESCRIPTION
C1504	ECQB1H103JF	CAP,P .01UF-J-50V	C2353	ECA1HM100	CAP,E 10UF/50V
C1505	ECA1VMH470B	CAP,E 47UF-35V	C2354	EEANA1E100B	CAP,E 10UF-25V
C1506	ECJ2VF1H102Z	CAP,C .001UF-Z-50V	C2355	ECA1HM100	CAP,E 10UF/50V
C1507	ECA1HM220	CAP,E 22UF/50V	C2356	ECA1HM100	CAP,E 10UF/50V
C1508	ECKD3D151KB	CAP,C 150PF-K-2KV	C2357	ECA1HM100	CAP,E 10UF/50V
C1509	ECQM6223KZ	CAP,P .022UF-K-600V	C2358	ECJ2VB1H153K	CAP,C .015UF-K-50V
C1510	ECQM4223KZ	CAP,P .022UF-K-400V	C2359	ECA1HM0R1	CAP,E 0.1UF/50V
C1511	ECA1HM010	CAP,E 1.0UF/50V	C2360	ECA1HM100	CAP,E 10UF/50V
C1512	ECKD3D102KB	CAP,C .001UF-K-2KV	C2361	ECA1HM100	CAP,E 10UF/50V
C1513	ECKD3A471KB	CAP,C 470PF-K-1KV	C2364	ECA1HM100	CAP,E 10UF/50V
C1514	ECKD3A391KB	CAP,C 390PF-K-1KV	C2365	ECA1HM100	CAP,E 10UF/50V
C1515	ECKD3A152KB	CAP,C .0015UF-K-1KV	C2366	ECJ2VB1H153K	CAP,C .015UF-K-50V
C1516	ECKD3A102KB	CAP,C .001UF-K-1KV	C2367	ECA1HM0R1	CAP,E 0.1UF/50V
C1517	ECKD3A151KB	CAP,C 150PF-K-1KV	C2368	ECA1HMR47	CAP,E .47UF/50V
C1518	ECKD3A182KB	CAP,C .0018UF-K-1KV	C2369	ECA1CM101	CAP,E 100UF/16V
C1519	ECA1VM470	CAP,E 47UF/35V	C2370	EEANA1E100B	CAP,E 10UF-25V
C1520	ECA1HM100	CAP,E 10UF/50V	C2371	ECA1CM101	CAP,E 100UF/16V
C2201	ECEA1HN4R7U	CAP,E 4.7UF/50V	C2372	ECJ2VB1C104K	CAP,C .1UF-I-16V
C2202	ECJ2VB1H562K	CAP,C .0056UF-K-50V	C2373	ECJ2VB1H103K	CAP,C .01UF-K-50V
C2203	ECQB1H123JF	CAP,P .012UF-J-50V	C2374	ECEA1CN220U	CAP,E 22UF-16V
C2204	ECA1HM010	CAP,E 1.0UF/50V	C2375	ECA1HM100	CAP,E 10UF/50V
C2205	ECA1HM4R7	CAP,E 4.7UF/50V	C2376	ECA1HM010	CAP,E 1.0UF/50V
C2206	ECA1HM100	CAP,E 10UF/50V	C2377	ECA1HM010	CAP,E 1.0UF/50V
C2207	ECA1HM4R7	CAP,E 4.7UF/50V	C2378	ECA1HM100	CAP,E 10UF/50V
C2208	ECA1CM101	CAP,E 100UF/16V	C2379	ECA1HM100	CAP,E 10UF/50V
C2209	ECEA1HN4R7U	CAP,E 4.7UF/50V	C2380	ECA1HM010	CAP,E 1.0UF/50V
C2210	ECA1HM4R7	CAP,E 4.7UF/50V	C2381	ECA1HM010	CAP,E 1.0UF/50V
C2211	ECEA1HN4R7U	CAP,E 4.7UF/50V	C2382	ECA1HM010	CAP,E 1.0UF/50V
C2212	ECJ2VC1H272J	CAP,C .0027UF-J-50V	C2383	ECA1HM100	CAP,E 10UF/50V
C2213	ECQB1H473JF	CAP,P .047UF-J-50V	C2502	ECJ2VF1H103Z	CAP,C .01UF-Z-50V
C2214	ECSF1CE335VB	CAP,E 33MF-16V	C2521	ECJ2VC1H820J	CAP,C 82PF-J-50V
C2215	ECEA1HN4R7U	CAP,E 4.7UF/50V	C2522	ECJ2VC1H820J	CAP,C 82PF-J-50V
C2216	ECSF1CE106VB	CAP,E 33UF-16V	C2523	ECJ2VC1H820J	CAP,C 82PF-J-50V
C2217	ECA1HM010	CAP,E 1.0UF/50V	C2557	ECA1HM100	CAP,E 10UF/50V
C2301	ECA1VM101	CAP,E 100UF/35V	C2558	ECJ2VF1H103Z	CAP,C .01UF-Z-50V
C2302	ECA1HM2R2	CAP,E 2.2UF/50V	C2559	ECJ2VB1C104K	CAP,C .1UF-I-16V
C2303	ECJ2VB1H222K	CAP,C .0022UF-K-50V	C2560	ECJ2VB1C104K	CAP,C .1UF-I-16V
C2305	ECA1VM101	CAP,E 100UF/35V	C2561	ECJ2VB1C104K	CAP,C .1UF-I-16V
C2306	ECA1HM2R2	CAP,E 2.2UF/50V	C2562	ECJ2VF1H103Z	CAP,C .01UF-Z-50V
C2307	ECJ2VB1H222K	CAP,C .0022UF-K-50V	C2563	ECA1HM220	CAP,E 22UF/50V
C2309	ECA1VM101	CAP,E 100UF/35V	C2565	ECJ2VF1H103Z	CAP,C .01UF-Z-50V
C2310	ECA1VM222	CAP,E 2200UF/35V	C2566	ECA1HM4R7	CAP,E 4.7UF/50V
C2311	ECQB1H104JF	CAP,P .1UF-J-50V	C2567	ECA1HM4R7	CAP,E 4.7UF/50V
C2312	ECA1VM470	CAP,E 47UF/35V	C2568	TCUY1C105ZFN	CAP,C 1UF-Z-16V
C2313	ECA1HM332	CAP,E 3300UF-50V	C2569	TCUY1C105ZFN	CAP,C 1UF-Z-16V
C2314	ECA1VM222	CAP,E 2200UF/35V	C2571	TCUY1C105ZFN	CAP,C 1UF-Z-16V
C2315	ECQB1H104JF	CAP,P .1UF-J-50V	C2572	ECA1CM221	CAP,E 220UF/16V
C2316	ECA1VM101	CAP,E 100UF/35V	C2573	ECJ2VF1H103Z	CAP,C .01UF-Z-50V
C2319	ECJ2VF1H103Z	CAP,C .01UF-Z-50V	C2574	ECJ2VF1H103Z	CAP,C .01UF-Z-50V
C2351	ECJ2VB1E473K	CAP,C .047UF-K-25V	C2575	ECJ2VF1H103Z	CAP,C .01UF-Z-50V
C2352	ECJ2VB1E473K	CAP,C .047UF-K-25V	C2576	ECJ2VF1H103Z	CAP,C .01UF-Z-50V

REPLACEMENT PARTS LIST

Models: CT-32HX40B/CB & CT-36HX40B/CB

Important Safety Notice: Components printed in **BOLD TYPE** have special characteristics important for safety. When replacing any of these components use only manufacturer's specified parts.

REF NO.	PART NO.	DESCRIPTION
C2578	ECA1CM471	CAP,E 470UF/16V
C2579	ECA1CM102	CAP,E 1000UF/16V
C2580	ECA1HMR47	CAP,E .47UF/50V
C2581	ECJ2VF1H103Z	CAP,C .01UF-Z-50V
C2582	ECJ2VF1H103Z	CAP,C .01UF-Z-50V
C2583	ECJ2VF1H103Z	CAP,C .01UF-Z-50V
C2584	TCUY1C105ZFN	CAP,C 1UF-Z-16V
C2585	TCUY1C105ZFN	CAP,C 1UF-Z-16V
C2586	TCUY1C105ZFN	CAP,C 1UF-Z-16V
C2587	ECJ2VF1H103Z	CAP,C .01UF-Z-50V
C2588	ECA1CM102	CAP,E 1000UF/16V
C2593	ECJ2VF1H103Z	CAP,C .01UF-Z-50V
C2594	ECJ2VF1H103Z	CAP,C .01UF-Z-50V
C2595	ECJ2VF1H103Z	CAP,C .01UF-Z-50V
C2599	ECA1CM101	CAP,E 100UF/16V
C3001	ECEA1CKA470	CAP,E 47UF/16V
C3002	ECJ2VF1H103Z	CAP,C .01UF-Z-50V
C3004	ECEA1CKA470	CAP,E 47UF/16V
C3006	ECEA1HNO10U	CAP,E 1UF/50V
C3012	ECA1CM221	CAP,E 220UF/16V
C3018	ECJ2VF1H103Z	CAP,C .01UF-Z-50V
C3019	ECJ2VF1H103Z	CAP,C .01UF-Z-50V
C3054	ECEA1CKA100	CAP,E 10UF/16V
C3055	ECEA1CKA100	CAP,E 10UF/16V
C3059	ECEA1CKA100	CAP,E 10UF/16V
C3060	ECEA1CKA100	CAP,E 10UF/16V
C3071	ECJ2VF1H103Z	CAP,C .01UF-Z-50V
C3072	ECEA1CKA100	CAP,E 10UF/16V
C3073	ECEA1CKA100	CAP,E 10UF/16V
C3074	ECEA1HKA010	CAP,E 1.0UF/50V
C3075	ECEA1HKA010	CAP,E 1.0UF/50V
C3076	ECJ2VF1H103Z	CAP,C .01UF-Z-50V
C3077	ECEA1CKA100	CAP,E 10UF/16V
C3078	ECEA1CKA100	CAP,E 10UF/16V
C3079	ECEA1HKA010	CAP,E 1.0UF/50V
C3080	ECEA1HKA010	CAP,E 1.0UF/50V
C3081	ECEA1HKA010	CAP,E 1.0UF/50V
C3082	ECEA1HKA010	CAP,E 1.0UF/50V
C3083	ECEA1CKA100	CAP,E 10UF/16V
C3084	ECEA1HKA010	CAP,E 1.0UF/50V
C3085	ECEA1HKA010	CAP,E 1.0UF/50V
C3086	ECA1CM471	CAP,E 470UF/16V
C3104	ECJ2VF1H103Z	CAP,C .01UF-Z-50V
C3105	ECA1HM010	CAP,E 1.0UF/50V
C3106	ECA1HM010	CAP,E 1.0UF/50V
C3107	ECEA1HN100U	CAP,E 10UF/50V
C3108	ECEA1HN100U	CAP,E 10UF/50V
C3109	ECEA1CKA100	CAP,E 10UF/16V
C3110	ECEA1CKA100	CAP,E 10UF/16V
C3111	ECEA1HKA010	CAP,E 1.0UF/50V
C3154	ECA1HM010	CAP,E 1.0UF/50V

REF NO.	PART NO.	DESCRIPTION
C3155	ECA1HM010	CAP,E 1.0UF/50V
C3207	ECA1CM101	CAP,E 100UF/16V
C3208	ECJ2VF1H103Z	CAP,C .01UF-Z-50V
C3209	ECJ2VF1H103Z	CAP,C .01UF-Z-50V
C3210	ECA1CM101	CAP,E 100UF/16V
C3211	ECJ2VF1H103Z	CAP,C .01UF-Z-50V
C3212	ECEA1CKA100	CAP,E 10UF/16V
C3213	ECEA1CKA100	CAP,E 10UF/16V
C3214	ECEA1CKA100	CAP,E 10UF/16V
C3215	ECEA1CKA100	CAP,E 10UF/16V
C3216	ECEA1CKA100	CAP,E 10UF/16V
C3217	ECEA1CKA100	CAP,E 10UF/16V
C3218	ECJ2VF1H103Z	CAP,C .01UF-Z-50V
C3219	ECJ2VF1H103Z	CAP,C .01UF-Z-50V
C3220	ECA1CM470	CAP,E 47UF/16V
C3222	ECJ2VF1H103Z	CAP,C .01UF-Z-50V
C3223	ECJ2VF1H103Z	CAP,C .01UF-Z-50V
C3224	ECEA1CKA100	CAP,E 10UF/16V
C3225	ECEA1CKA100	CAP,E 10UF/16V
C3227	ECEA1CKA100	CAP,E 10UF/16V
C3229	ECEA1CKA100	CAP,E 10UF/16V
C3230	ECEA1CKA100	CAP,E 10UF/16V
C3231	ECJ2VF1H103Z	CAP,C .01UF-Z-50V
C3248	ECEA1CKA100	CAP,E 10UF/16V
C3801	TACCX103T50V	CAP,C .01UF/50V
C3802	ECA1VM470	CAP,E 47UF/35V
C3803	TACCX103T50V	CAP,C .01UF/50V
C3804	ECQE2104KF	CAP,P .10UF-K-200V
C3805	ECKD2H561KB	CAP,C 560PF-K-500V
C3807	ECCF1H100DC	CAP,C 10PF-D-50V
C3808	ECA1HM010	CAP,E 1.0UF/50V
C3809	ECA1HMH010B	CAP,E 1.0UF-50V
C3810	ECA1HMH010B	CAP,E 1.0UF-50V
C3811	TACCX103T50V	CAP,C .01UF/50V
C3812	ECA1VM470	CAP,E 47UF/35V
C3813	TACCX103T50V	CAP,C .01UF/50V
C3814	ECQE2104KF	CAP,P .10UF-K-200V
C3815	ECKD2H561KB	CAP,C 560PF-K-500V
C3817	ECCF1H220JC	CAP,C 22PF-J-50V
C3819	ECA1HM220	CAP,E 22UF/50V
C3821	TACCX103T50V	CAP,C .01UF/50V
C3822	ECA1VMH470B	CAP,E 47UF-35V
C3823	TACCX103T50V	CAP,C .01UF/50V
C3824	ECQE2104KF	CAP,P .10UF-K-200V
C3825	ECKD2H561KB	CAP,C 560PF-K-500V
C3827	ECCF1H270JC	CAP,C 27PF-J-50V
C3828	ECA1CM221	CAP,E 220UF/16V
C3831	TACCX103T50V	CAP,C .01UF/50V
C3832	ECA1VM470	CAP,E 47UF/35V
C3833	ECA2EM470	CAP,E 47UF-250V
C3836	ECKD3D332KB	CAP,C .0033UF-K-2KV

REPLACEMENT PARTS LIST

Models: CT-32HX40B/CB & CT-36HX40B/CB

Important Safety Notice: Components printed in **BOLD TYPE** have special characteristics important for safety. When replacing any of these components use only manufacturer's specified parts.

REF NO.	PART NO.	DESCRIPTION	REF NO.	PART NO.	DESCRIPTION
C5001	ECA1HM4R7	CAP,E 4.7UF/50V	D408	MA152K	DIODE
C5002	ECA1HM4R7	CAP,E 4.7UF/50V	D409	MA165	DIODE
C5003	ECQV1H334JL	CAP,P .33UF-J-50V	D415	MA4027H	DIODE
C5004	ECQV1H334JL	CAP,P .33UF-J-50V	D460	MA4062M	DIODE, ZENER
C5005	ECA1VM470	CAP,E 47UF/35V	D461	MA4062M	DIODE, ZENER
C5016	ECA1HM100	CAP,E 10UF/50V	D464	MA4051M	DIODE
C6518	ECJ2VC1H471J	CAP,C 470PF-J-50V	D467	MA3062M	DIODE
C6520	ECJ2VB1H103K	CAP,C .01UF-K-50V	D468	MA3062M	DIODE
C6527	ECJ2VC1H101J	CAP,C 100PF-J-50V	D501	D1NL40V70	DIODE
C6529	ECEA1HKAR47	CAP,E .47UF/50V	D502	MA4150M	DIODE
C6531	ECEA1HKA4R7	CAP,E 4.7UF/50V	D503	FMV3GUSLF730	DIODE
C6532	ECEA1HKAR47	CAP,E .47UF/50V	D504	MA4300L	DIODE
C6533	ECJ2VB1H472K	CAP,C .0047UF-K-50V	D509	MA165	DIODE
C6534	ECEA1HKAR47	CAP,E .47UF/50V	D510	MA4082M	DIODE
C6535	ECJ2VF1H103Z	CAP,C .01UF-Z-50V	D511	AU02A	DIODE CT-32HX40B, CT-32HX40CB
C6536	TCUY1C474KBM	CAP,C .47UF-K-16V	D511	D1NL40V70	DIODE CT-36HX40B, CT-36HX40CB
C6537	ECJ2VB1H103K	CAP,C .01UF-K-50V	D512	D1NL40V70	DIODE
C6538	ECJ2VF1C105Z	CAP,C 1.0UF-Z-16V	D515	D1NL40V70	DIODE
C6539	ECJ2VB1C104K	CAP,C .1UF-I-16V	D516	MA4051L	DIODE, ZENER
C6540	ECJ2VC1H150J	CAP,C 15PF-J-50V	D517	D1NL40V70	DIODE
C6541	ECJ2VB1C104K	CAP,C .1UF-I-16V	D518	D1NL40V70	DIODE
C6546	ECEA1HKN010	CAP,E 1.0UF/50V	D550	RU3NLFA1	DIODE
C6547	ECJ2VB1H103K	CAP,C .01UF-K-50V	D560	MA4036L	DIODE, ZENER
C6548	ECEA1HKAR47	CAP,E .47UF/50V	D561	MA165	DIODE
C6549	ECJ2VB1H103K	CAP,C .01UF-K-50V	D562	MA165	DIODE
C6550	ECEA1HKAR47	CAP,E .47UF/50V	D703	D1NL40V70	DIODE
C6551	ECJ2VB1C104K	CAP,C .1UF-I-16V	D707	MA4150M	DIODE
C6552	ECJ2VB1C104K	CAP,C .1UF-I-16V	D708	MA4150M	DIODE
C6553	ECJ2VB1C104K	CAP,C .1UF-I-16V	D711	ERA22-06	DIODE
C6554	ECJ2VC1H471J	CAP,C 470PF-J-50V	D751	MA165	DIODE
C6556	ECJ2VB1H103K	CAP,C .01UF-K-50V	D801	D6SB80	DIODE
C6557	ECA1CM221	CAP,E 220UF/16V	D802	MA700A	DIODE
C6558	ECA1CM471	CAP,E 470UF/16V	D803	TAP119M1R5	DIODE
C6563	TCUY1C225ZFN	CAP,C 2.2UF-Z-16V	D806	AU01Z	DIODE
C6564	TCUY1C225ZFN	CAP,C 2.2UF-Z-16V	D807	MA165	DIODE
C6565	TCUY1C225ZFN	CAP,C 2.2UF-Z-16V	D809	ERZV10D391	DIODE
C6567	TCUY1C225ZFN	CAP,C 2.2UF-Z-16V	D811	ERA15-01	DIODE
C6574	ECJ2VC1H151J	CAP,C 150PF-J-50V	D814	MA165	DIODE
C6575	ECJ2VC1H101J	CAP,C 100PF-J-50V	D815	MA165	DIODE
C6576	ECJ2VF1H103Z	CAP,C .01UF-Z-50V	D816	MA165	DIODE
DIODES			D817	MA4220L	DIODE, ZENER
D007	MA4150H	DIODE, ZENER	D818	MA4200M	DIODE
D008	MA4150H	DIODE, ZENER	D824	TMPG10G3	DIODE
D009	MA165	DIODE	D825	FMGG2CS	DIODE
D010	MA4030M	DIODE, ZENER	D826	AU02Z	DIODE
D401	MA700A	DIODE	D827	MA6D90	DIODE
D402	MA4270M	DIODE	D828	MA6D90	DIODE
D403	MA152K	DIODE	D829	S2L20UP1518	DIODE
D405	ERA15-02	DIODE	D830	MA6D90	DIODE
D406	ERA15-02	DIODE	D831	MA165	DIODE
D407	MA152K	DIODE	D832	MA165	DIODE

REPLACEMENT PARTS LIST

Models: CT-32HX40B/CB & CT-36HX40B/CB

Important Safety Notice: Components printed in **BOLD TYPE** have special characteristics important for safety. When replacing any of these components use only manufacturer's specified parts.

REF NO.	PART NO.	DESCRIPTION
D833	MA4100M	DIODE, ZENER
D834	AU02Z	DIODE
D835	MA165	DIODE
D836	MA4180M	DIODE, ZENER
D837	MA165	DIODE
D839	MA4039M	DIODE, ZENER
D840	MA165	DIODE
D841	MA165	DIODE
D861	TVSA81004	DIODE
D862	TVSA81004	DIODE
D875	RK34LFC4	DIODE
D876	MA165	DIODE
D877	MA165	DIODE
D878	RK34LFC4	DIODE
D881	TMPG10G3	DIODE
D884	TMPG12G3	DIODE
D893	MA165	DIODE
D894	MA165	DIODE
D895	MA165	DIODE
D896	MA165	DIODE
D899	MA165	DIODE
D954	MA165	DIODE
D957	MA165	DIODE
D1001	LN81RPHCF3	DIODE
D1501	MA3075H	DIODE
D1502	MA4062L	DIODE
D1503	MA4030H	DIODE
D1504	MA4030H	DIODE
D1505	RP1HLFA5	DIODE
D1508	MA165	DIODE
D1509	AU02A	DIODE
D1510	AU02A	DIODE
D1513	MA165	DIODE
D2304	MA165	DIODE
D2305	MA165	DIODE
D2308	MA4390M	DIODE
D2309	MA4390M	DIODE
D2310	MA4390M	DIODE
D2311	MA4390M	DIODE
D2320	MA4390M	DIODE
D2321	MA4390M	DIODE
D2501	MA152A	DIODE
D2502	MA152A	DIODE
D2503	MA3062M	DIODE
D2504	MA3062M	DIODE
D2506	MA152A	DIODE
D3051	MA3110M	DIODE, ZENER
D3052	MA3110M	DIODE, ZENER
D3053	MA3110M	DIODE, ZENER
D3054	MA3110M	DIODE, ZENER
D3055	MA3110M	DIODE, ZENER

REF NO.	PART NO.	DESCRIPTION
D3056	MA3110M	DIODE, ZENER
D3057	MA3110M	DIODE, ZENER
D3058	MA3110M	DIODE, ZENER
D3059	MA3110M	DIODE, ZENER
D3060	MA3110M	DIODE, ZENER
D3061	MA3110M	DIODE, ZENER
D3062	MA3110M	DIODE, ZENER
D3064	MA3110M	DIODE, ZENER
D3065	MA3110M	DIODE, ZENER
D3066	MA3110M	DIODE, ZENER
D3067	MA3110M	DIODE, ZENER
D3068	MA3110M	DIODE, ZENER
D3070	MA3110M	DIODE, ZENER
D3071	MA3110M	DIODE, ZENER
D3072	MA3110M	DIODE, ZENER
D3073	MA3110M	DIODE, ZENER
D3074	MA3110M	DIODE, ZENER
D3075	MA3110M	DIODE, ZENER
D3076	MA3110M	DIODE, ZENER
D3077	MA3110M	DIODE, ZENER
D3078	MA3110M	DIODE, ZENER
D3079	MA3110M	DIODE, ZENER
D3080	MA3110M	DIODE, ZENER
D3081	MA3110M	DIODE, ZENER
D3082	MA3110M	DIODE, ZENER
D3086	MA3110M	DIODE, ZENER
D3087	MA3110M	DIODE, ZENER
D3088	MA3110M	DIODE, ZENER
D3089	MA3110M	DIODE, ZENER
D3090	MA3110M	DIODE, ZENER
D3091	MA3110M	DIODE, ZENER
D3151	MA4140M	DIODE
D3152	MA4140M	DIODE
D3153	MA4140M	DIODE
D3154	MA4140M	DIODE
D3155	MA4140M	DIODE
D3156	MA4140M	DIODE
D3802	MA188	DIODE
D3803	MA188	DIODE
D3804	MA188	DIODE
D3806	MA4130M	DIODE
D3807	MA165	DIODE
D3808	MA188	DIODE
D3809	MA188	DIODE
D3810	MA188	DIODE
D3811	MA188	DIODE
D3812	MA188	DIODE
D3813	MA188	DIODE
D3814	MA188	DIODE
D3815	MA188	DIODE
D3816	MA188	DIODE

REPLACEMENT PARTS LIST

Models: CT-32HX40B/CB & CT-36HX40B/CB

Important Safety Notice: Components printed in **BOLD TYPE** have special characteristics important for safety. When replacing any of these components use only manufacturer's specified parts.

REF NO.	PART NO.	DESCRIPTION
D3818	MA4100L	DIODE
D3819	MA4100L	DIODE
D3820	MA4100L	DIODE
D3822	MA4150H	DIODE, ZENER
D3824	MA4120M	DIODE
D3825	MA4120M	DIODE
D3826	MA4120M	DIODE
IC804	TVSS1WBS20	DIODE, BRIDGE RECTIFIER
FUSES		
F801	XBA1C63NU100	FUSE 6.3A/125V
INTEGRATED CIRCUITS		
IC001	MN102H51KTB2	INT CKT
IC002	TVR2AJ063	INT CKT CT-32HX40B/CB
IC002	TVR2AJ064	INT CKT CT-36HX40B/CB
IC003	PQ3RD03M	INT CKT
IC004	PQ1R50	INT CKT
IC005	PST9128NR	INT CKT
IC451	LA7876N	INT CKT
IC452	CXA1875AM-T4	INT CKT
IC453	TC74HC107AF	INT CKT
IC454	AN6562S-E1	INT CKT
IC500	LA6510	INT CKT
IC510	TC74HC221AF	INT CKT
IC511	AN6914S-E1	INT CKT
IC751	AN6914S-E1	INT CKT
IC752	IR2117	INT CKT
IC801	AN8029	INT CKT
IC802	SE130NLF4	INT CKT
IC803	PC123FY2	INT CKT
IC804	TVSS1WBS20	DIODE, BRIDGE RECTIFIER
IC811	PC123FY2	INT CKT
IC871	SI-8050S	INT CKT
IC872	PQ15RW1B	INT CKT
IC875	SI-8090S	INT CKT
IC876	PQ12RD1B	INT CKT
IC880	PQ15RW1B	INT CKT
IC1501	AN6562S-E1	INT CKT
IC2201	CXA2104S	INT CKT
IC2301	C1AA00000492	INT CKT
IC2351	AN7396K	INT CKT
IC2352	BA15218N	INT CKT
IC2353	TC4066BP	INT CKT
IC2505	AN5394FB	INT CKT
IC3003	CXA2069Q	INT CKT
IC3202	SN761243PG	INT CKT
IC3801	TDA6111Q	INT CKT
IC3802	TDA6111Q	INT CKT
IC3803	TDA6111Q	INT CKT
IC5001	PUB4301	INT CKT
IC5002	AN6564	INT CKT
IC6502	CXA2019AQ	INT CKT

REF NO.	PART NO.	DESCRIPTION
IC6503	M52036SP	INT CKT
IC6504	M52055FP-E2	INT CKT
RM001	PNA4601M04TV	INT CKT
COILS		
L003	TLUABTA100K	COIL, PEAKING 10UH
L004	TLUABTA100K	COIL, PEAKING 10UH
L006	EXCELSA35T	FERRITE BEAD
L007	EXCELSA35T	FERRITE BEAD
L009	ELESN330JA	COIL, PEAKING 33UH
L010	ELESN330JA	COIL, PEAKING 33UH
L011	ELESN330JA	COIL, PEAKING 33UH
L012	ELESN330JA	COIL, PEAKING 33UH
L401	EXCELSA39	FERRITE BEAD
L404	TSKA064-1	FERRITE BEAD
L500	TALL08TR56MA	COIL
L503	TALL13N103JB	COIL
L506	EXCELSA24T	FERRITE BEAD
L552	TLHE044	COIL
L554	TLHE058	COIL
L711	ELESN100KA	COIL, PEAKING 10UH
L751	ELC18B121F	COIL
L752	TALFP15B152K	COIL
L759	EXCELSA35T	FERRITE BEAD
L801	ELF24V037A	LINE FILTER
L802	ELF24V037A	LINE FILTER
L805	EXCELSA35T	FERRITE BEAD
L807	TSKA064-1	FERRITE BEAD
L812	EXCELSA35B	FERRITE BEAD
L814	TALL08T101KA	LINE FILTER
L815	EXCELSA39E	FERRITE BEAD
L816	EXCELSA39E	FERRITE BEAD
L817	EXCELDR35	FERRITE BEAD
L818	EXCELDR35	FERRITE BEAD
L819	EXCELSA24T	FERRITE BEAD
L820	EXCELSA24T	FERRITE BEAD
L821	EXCELDR35	FERRITE BEAD
L822	EXCELDR35	FERRITE BEAD
L824	EXCELDR35	FERRITE BEAD
L825	TLUADTB121K	COIL
L826	TLUADTB820K	COIL
L827	TALL08T470KA	LINE FILTER
L829	EXCELSA35T	FERRITE BEAD
L850	ELESN101JA	COIL, PEAKING 100UH
L875	TALFP15B151K	LINE FILTER
L878	TALFP15B221K	LINE FILTER
L882	TALL08T470KA	LINE FILTER
L885	TALL08T220KA	TRANSFORMER, LINE FILTER
L887	TALL08T330KA	LINE FILTER
L891	TALL08T101KA	LINE FILTER
L904	TLTABT560K	COIL
L953	EXCELSA35T	FERRITE BEAD

REPLACEMENT PARTS LIST

Models: CT-32HX40B/CB & CT-36HX40B/CB

Important Safety Notice: Components printed in **BOLD TYPE** have special characteristics important for safety. When replacing any of these components use only manufacturer's specified parts.

REF NO.	PART NO.	DESCRIPTION
L956	EXCELSA35T	FERRITE BEAD
L1501	TALFP15B152K	COIL
L2301	EXCELSA35T	FERRITE BEAD
L2507	TSKA064-1	FERRITE BEAD
L2508	TSKA064-1	FERRITE BEAD
L3001	EXCELSA35T	FERRITE BEAD
L3801	ELESN100JA	COIL, PEAKING 10UH
L3802	ELESN100JA	COIL, PEAKING 10UH
L3803	ELESN100JA	COIL, PEAKING 10UH
L5001	EXCELSA35T	FERRITE BEAD
L5002	EXCELD35	FERRITE BEAD
JS2403	EXCELD35	FERRITE BEAD
JS2404	EXCELSA35T	FERRITE BEAD
TRANSISTORS		
Q002	2SD601ARTX	TRANSISTOR
Q003	2SD601ARTX	TRANSISTOR
Q007	2SD601ARTX	TRANSISTOR
Q009	2SD601ARTX	TRANSISTOR
Q010	2SD601ARTX	TRANSISTOR
Q011	2SD601ARTX	TRANSISTOR
Q012	2SD601ARTX	TRANSISTOR
Q013	2SD601ARTX	TRANSISTOR
Q401	2SD1266AP	TRANSISTOR
Q402	2SB709ARTX	TRANSISTOR
Q403	2SB941P	TRANSISTOR
Q404	2SD601ASTX	TRANSISTOR
Q405	2SB709ARTX	TRANSISTOR
Q406	2SD601ARTX	TRANSISTOR
Q407	2SC1741RSTP	TRANSISTOR
Q408	2SC1741RSTP	TRANSISTOR
Q452	2SB709ARTX	TRANSISTOR
Q454	2SD601ARTX	TRANSISTOR
Q455	2SB709ARTX	TRANSISTOR
Q456	2SB709ARTX	TRANSISTOR
Q457	2SD601ARTX	TRANSISTOR
Q458	2SD601ARTX	TRANSISTOR
Q501	2SK2962TPE6	TRANSISTOR
Q502	2SK2847LBMAT	TRANSISTOR
Q503	2SC1685QRS	TRANSISTOR
Q509	2SC1473QR	TRANSISTOR
Q510	2SC1473QR	TRANSISTOR
Q551	2SC5612LB228	TRANSISTOR
Q560	2SD601ARTX	TRANSISTOR
Q561	2SD601ARTX	TRANSISTOR
Q562	2SC1473QR	TRANSISTOR
Q563	2SC3941RTA	TRANSISTOR
Q751	2SK2538000LB	TRANSISTOR
Q752	2SD601ARTX	TRANSISTOR
Q754	2SD601ARTX	TRANSISTOR
Q755	FS10KM-06-AV	TRANSISTOR
Q801	2SK2917LB	TRANSISTOR

REF NO.	PART NO.	DESCRIPTION
Q802	2SC1685QRS	TRANSISTOR
Q803	2SC1685QRS	TRANSISTOR
Q804	2SA564AQRSTA	TRANSISTOR
Q805	2SC3311RSTA	TRANSISTOR
Q806	2SC1685QRS	TRANSISTOR
Q854	2SA19610QAHW	TRANSISTOR
Q880	2SB709ARTX	TRANSISTOR
Q902	2SC1685QRS	TRANSISTOR
Q951	2SA564AQRSTA	TRANSISTOR
Q952	2SC1685QRS	TRANSISTOR
Q955	2SB1569AF51	TRANSISTOR
Q956	2SD2400AF51	TRANSISTOR
Q1051	2SC1685QRS	TRANSISTOR
Q1501	2SK1006RF122	TRANSISTOR
Q1502	2SK1608LB	TRANSISTOR
Q1503	2SC5460LB	TRANSISTOR
Q1504	2SC1685QRS	TRANSISTOR
Q1505	2SC1685QRS	TRANSISTOR
Q1506	2SC1685QRS	TRANSISTOR
Q2301	2SD601ARTX	TRANSISTOR
Q2302	2SD601ARTX	TRANSISTOR
Q2303	2SB709ARTX	TRANSISTOR
Q2304	2SD601ARTX	TRANSISTOR
Q2351	2SD601ARTX	TRANSISTOR
Q2352	2SD601ARTX	TRANSISTOR
Q2353	2SB709ARTX	TRANSISTOR
Q2354	2SD601ARTX	TRANSISTOR
Q2355	2SD601ARTX	TRANSISTOR
Q2511	2SD601ARTX	TRANSISTOR
Q2513	2SD601ARTX	TRANSISTOR
Q2514	2SB709ARTX	TRANSISTOR
Q2516	2SD601ARTX	TRANSISTOR
Q2517	2SD601ARTX	TRANSISTOR
Q2518	2SD601ARTX	TRANSISTOR
Q2519	2SD601ARTX	TRANSISTOR
Q2528	2SD601ARTX	TRANSISTOR
Q2529	2SB709ARTX	TRANSISTOR
Q2533	2SD601ARTX	TRANSISTOR
Q3020	2SD601ARTX	TRANSISTOR
Q3021	2SD601ARTX	TRANSISTOR
Q3022	2SD601ARTX	TRANSISTOR
Q3023	2SD601ARTX	TRANSISTOR
Q3024	2SD601ARTX	TRANSISTOR
Q3025	2SD601ARTX	TRANSISTOR
Q3026	2SB709ARTX	TRANSISTOR
Q3027	2SD601ARTX	TRANSISTOR
Q3201	2SB709ARTX	TRANSISTOR
Q3202	2SB709ARTX	TRANSISTOR
Q3203	2SB709ARTX	TRANSISTOR
Q3220	2SB709ARTX	TRANSISTOR
Q3221	2SB709ARTX	TRANSISTOR

REPLACEMENT PARTS LIST

Models: CT-32HX40B/CB & CT-36HX40B/CB

Important Safety Notice: Components printed in **BOLD TYPE** have special characteristics important for safety. When replacing any of these components use only manufacturer's specified parts.

REF NO.	PART NO.	DESCRIPTION	REF NO.	PART NO.	DESCRIPTION
Q3222	2SB709ARTX	TRANSISTOR	R048	ERDS2TJ102	RES,C 1K-J-1/4
Q3223	2SB709ARTX	TRANSISTOR	R049	ERJ6GEYJ221	RES,M 220-J-1/10
Q3224	2SB709ARTX	TRANSISTOR	R050	ERJ6GEYJ221	RES,M 220-J-1/10
Q3225	2SB709ARTX	TRANSISTOR	R052	ERDS2TJ272	RES,C 2.7K-J-1/4
Q6504	2SB709ARTX	TRANSISTOR	R053	ERDS2TJ272	RES,C 2.7K-J-1/4
Q6505	2SD601ARTX	TRANSISTOR	R054	ERJ6GEYJ101	RES,M 100-J-1/10
Q6514	2SD601ARTX	TRANSISTOR	R055	ERJ6GEYJ101	RES,M 100-J-1/10
RELAYS			R061	ERJ6GEYJ471	RES,M 470-J-1/10
RL801	TSEH8011	RELAY	R063	ERJ6GEYJ102	RES,M 1K-J-1/10
RL802	TSE10814	RELAY	R064	ERJ6GEYJ241	RES,M 240-J-1/10W
RL803	TSEH0005	RELAY	R065	ERJ6GEYJ471	RES,M 470-J-1/10
RL804	TSEH0005	RELAY	R067	ERJ6GEYJ102	RES,M 1K-J-1/10
RESISTORS			R068	ERJ6GEYJ241	RES,M 240-J-1/10W
R001	ERJ6GEYJ102	RES,M 1K-J-1/10	R078	ERJ6GEYJ103	RES,M 10K-J-1/10
R002	ERDS2TJ272	RES,C 2.7K-J-1/4	R079	ERJ6GEYJ223	RES,M 22K-J-1/10
R003	ERDS2TJ272	RES,C 2.7K-J-1/4	R080	ERJ6GEYJ220	RES,M 22-J-1/10
R004	ERJ6GEYJ103	RES,M 10K-J-1/10	R081	ERDS2TJ100	RES,C 10-J-1/4
R006	ERJ6GEYJ182	RES,M 1.8K-J-1/10	R085	ERDS2TJ103	RES,C 10K-J-1/4
R007	ERJ6GEYJ182	RES,M 1.8K-J-1/10	R086	ERJ6GEYJ103	RES,M 10K-J-1/10
R008	ERJ6GEYJ182	RES,M 1.8K-J-1/10	R087	ERJ6GEYJ472	RES,M 4.7K-J-1/10
R009	ERJ6GEYJ103	RES,M 10K-J-1/10	R088	ERJ6GEYJ123	RES,M 12K-J-1/10
R010	ERJ6GEYJ103	RES,M 10K-J-1/10	R089	ERJ6GEYJ103	RES,M 10K-J-1/10
R011	ERJ6GEYJ103	RES,M 10K-J-1/10	R090	ERJ6GEYJ102	RES,M 1K-J-1/10
R013	ERJ6GEYJ102	RES,M 1K-J-1/10	R091	ERJ6GEYJ123	RES,M 12K-J-1/10
R014	ERDS2TJ102	RES,C 1K-J-1/4	R092	ERJ6GEYJ103	RES,M 10K-J-1/10
R015	ERDS2TJ102	RES,C 1K-J-1/4	R093	ERJ6GEYJ102	RES,M 1K-J-1/10
R017	ERDS2TJ102	RES,C 1K-J-1/4	R099	ERDS1TJ150	RES,C 15K-J-1/2W
R018	ERDS2TJ102	RES,C 1K-J-1/4	R401	ERJ6GEYJ103	RES,M 10K-J-1/10
R019	ERDS2TJ102	RES,C 1K-J-1/4	R402	ERG2FJ152H	RES,M 1500-J-2W
R022	ERJ6GEYJ562	RES,M 5.6K-J-1/10	R403	ERJ6GEYJ473	RES,M 47K-J-1/10
R024	ERDS2TJ103	RES,C 10K-J-1/4	R404	ERJ6GEYJ103	RES,M 10K-J-1/10
R025	ERDS2TJ102	RES,C 1K-J-1/4	R405	ERJ6GEYJ103	RES,M 10K-J-1/10
R026	ERDS2TJ102	RES,C 1K-J-1/4	R406	ERG1SJ681P	RES,M 680-J-1W
R027	ERJ6GEYJ333	RES,M 33K-J-1/10	R407	ERJ6GEYJ473	RES,M 47K-J-1/10
R028	ERJ6GEYJ682	RES,M 6.8K-J-1/10	R408	ERDS2TJ272	RES,C 2.7K-J-1/4
R029	ERJ6ENF2201	RES,M 2.2K-F-1/10	R409	ERJ6GEYJ563	RES,M 56K-J-1/10
R030	ERJ6ENF6801	RES,M 6.8K-F-1/10	R410	ERJ6GEYJ224	RES,M 220K-J-1/10
R031	ERJ6ENF5101	RES,M 5.1K-F-1/10	R411	ERJ6GEYJ392	RES,M 3.9K-J-1/10
R032	ERJ6ENF1200	RES,M 120-F-1/10W	R412	ERJ6GEYJ103	RES,M 10K-J-1/10
R033	ERJ6ENF1200	RES,M 120-F-1/10W	R413	ERDS2TJ104	RES,C 100K-J-1/4
R034	ERJ6ENF1200	RES,M 120-F-1/10W	R414	ERX1SJ1R2	RES,M 1.2-J-1W
R035	ERJ6GEYJ331	RES,M 330-J-1/10	R415	ERG3FJ331H	RES,M 330-J-3W
R036	ERJ6GEYJ332	RES,M 3.3K-J-1/10	R416	ERJ6ENF3900	RES,M 390-F-1/10
R037	ERJ6GEYJ151	RES,M 150-J-1/10	R417	ERJ6GEYJ272	RES,M 2.7K-J-1/10
R039	ERDS2TJ332	RES,C 1K-J-1/4	R418	ERJ6GEYJ473	RES,M 47K-J-1/10
R040	ERJ6GEYJ102	RES,M 1K-J-1/10	R419	ERJ6GEYJ222	RES,M 2.2K-J-1/10
R042	ERDS2TJ102	RES,C 1K-J-1/4	R420	ERJ6GEYJ102	RES,M 1K-J-1/10
R043	ERDS2TJ102	RES,C 1K-J-1/4	R421	ERJ6ENF1302	RES,M 13K-F-1/10W
R044	ERJ6GEYJ102	RES,M 1K-J-1/10	R422	ERJ6ENF1781	RES,M 1.78K-F-1/10W
R045	ERDS2TJ101	RES,C 100-J-1/4	R423	ERJ6GEYJ103	RES,M 10K-J-1/10
R047	ERDS2TJ221	RES,C 220-J-1/4	R424	ERJ6GEYJ472	RES,M 4.7K-J-1/10

REPLACEMENT PARTS LIST

Models: CT-32HX40B/CB & CT-36HX40B/CB

Important Safety Notice: Components printed in **BOLD TYPE** have special characteristics important for safety. When replacing any of these components use only manufacturer's specified parts.

REF NO.	PART NO.	DESCRIPTION
R425	ERDS1FJ1R0	RES,C 1.0-J-1/2
R426	ERJ6GEYJ123	RES,M 12K-J-1/10
R427	ERJ6GEYJ102	RES,M 1K-J-1/10
R428	ER0S2CKF9761	RES,M 9.76-F-1/4W
R429	ERJ6GEYJ182	RES,M 1.8K-J-1/10
R430	ER0S2CKF1500	RES,M 150-F-1/4W
R431	ER0S2CKF2000	RES,M 200-F-1/4W
R434	ERX12SJ2R2	RES,M 2.2-J-1/2W
R435	ERX12SJ2R2	RES,M 2.2-J-1/2W
R436	ERX12SJ2R2	RES,M 2.2-J-1/2W
R437	ERJ6GEYJ102	RES,M 1K-J-1/10
R438	ERJ6GEYJ102	RES,M 1K-J-1/10
R439	ERJ6GEYJ473	RES,M 47K-J-1/10
R440	ERG1SJ102P	RES,M 1K-J-1W
R441	ERJ6GEYJ560	RES,M 56-J-1/10
R442	ERJ6GEYJ560	RES,M 56-J-1/10
R443	ERJ6GEYJ562	RES,M 5.6K-J-1/10
R444	ERJ6GEYJ103	RES,M 10K-J-1/10
R445	ERJ6GEYJ103	RES,M 10K-J-1/10
R451	ERJ6GEYJ102	RES,M 1K-J-1/10
R453	ERDS1FJ221	RES,C 220-J-1/2
R454	ERJ6GEYJ561	RES,M 560-J-1/10
R455	ERJ6GEYJ222	RES,M 2.2K-J-1/10
R456	ERJ6GEYJ222	RES,M 2.2K-J-1/10
R457	ERJ6GEYJ103	RES,M 10K-J-1/10
R458	ERJ6GEYJ392	RES,M 3.9K-J-1/10
R459	ERJ6GEYJ473	RES,M 47K-J-1/10
R460	ERJ6GEYJ473	RES,M 47K-J-1/10
R461	ERJ6GEYJ473	RES,M 47K-J-1/10
R464	ERJ6GEYJ103	RES,M 10K-J-1/10
R465	ER0S2CKF2201	RES,M 2.2K-F-1/4
R470	ERJ6GEYJ683	RES,M 68K-J-1/10
R471	ER0S2CKF1332	RES,M 13.3-F-1/4W
R472	ERJ6ENF4121	RES,M 4.12K-F-1/10W
R495	ER0S2CKF4422	RES,M 44.2K-F-1/4
R496	ERJ6GEYJ102	RES,M 1K-J-1/10
R497	ERJ6GEYJ103	RES,M 10K-J-1/10
R499	ERJ6GEYJ222	RES,M 2.2K-J-1/10
R501	ERDS2TJ104	RES,C 100K-J-1/4
R502	ERDS2TJ680	RES,C 68-J-1/4
R503	ERG3FJ221H	RES,M 220-J-3W
R504	ERG1SJ102P	RES,M 1K-J-1W
R505	ERG1SJ100P	RES,M 10-J-1W
R510	ERG2FJ331H	RES,M 330-J-2W
R513	ERC12GK103	RES,C 10K-K-1/2W
R514	ER0S2CKF3302	RES,M 33K-F-1/4
R515	ER0S2CKF3162	RES,M 31.6-F-1/4
R516	ERDS2TJ101	RES,C 100-J-1/4
R517	ERG1SJ103P	RES,M 10K-J-1W
R518	ERDS1FJ1R5	RES,C 1.5-J-1/2 CT-36HX40B, CT-36HX40CB

REF NO.	PART NO.	DESCRIPTION
R520	ERQ14AJ2R2	RES,F 2.2-J-1/4
R521	ER0S2CKF7151	RES,M 7.15K-F-1/4
R522	ER0S2CKF2321	RES,M 2.32K-F-1/4
R524	EVMEGGA00B14	CONTROL 10K
R525	ERDS2TJ102	RES,C 1K-J-1/4
R526	ERQ12HJ1R0	RES,F 1.0-J-1/2
R527	ERDS2TJ472	RES,C 4.7K-J-1/4 CT-32HX40B, CT-32HX40CB
R532	ERDS1FJ1R0	RES,C 1.0-J-1/2 CT-36HX40B, CT-36HX40CB
R533	ERDS1FJ1R0	RES,C 1.0-J-1/2
R534	ER0S2CKF9102	RES,M 91K-F-1/4
R535	ERDS2TJ562	RES,C 5.6K-J-1/4
R536	ERDS2TJ101	RES,C 100-J-1/4
R537	ERDS2TJ272	RES,C 2.7K-J-1/4
R538	ERDS2TJ103	RES,C 10K-J-1/4
R550	ERDS2TJ622	RES,C 6.2K-J-1/4
R580	ERDS2TJ391	RES,C 390-J-1/4
R581	ERJ6ENF1152	RES,M 11.5K-F-1/10W
R582	ERDS2TJ680	RES,C 68-J-1/4
R583	ERJ6GEYJ822	RES,M 8.2K-J-1/10
R584	ERJ6GEYJ102	RES,M 1K-J-1/10
R585	ERJ6GEYJ682	RES,M 6.8K-J-1/10
R586	ERJ6GEYJ103	RES,M 10K-J-1/10
R587	ERJ6GEYJ101	RES,M 100-J-1/10
R588	ERJ6GEYJ103	RES,M 10K-J-1/10
R589	ERJ6GEYJ101	RES,M 100-J-1/10
R590	ERJ6GEYJ472	RES,M 4.7K-J-1/10
R591	ERJ6GEYJ332	RES,M 3.3K-J-1/10
R592	ERJ6GEYJ103	RES,M 10K-J-1/10
R595	ERDS2TJ273	RES,C 27K-J-1/4
R596	ERJ6GEYJ102	RES,M 1K-J-1/10
R701	ERJ6GEYJ103	RES,M 10K-J-1/10
R702	ERJ6GEYJ101	RES,M 100-J-1/10
R703	ERJ6GEYJ101	RES,M 100-J-1/10
R704	ERJ6GEYJ202	RES,M 2K-J-1/10
R705	ERJ6GEYJ103	RES,M 10K-J-1/10
R706	ERJ6GEYJ152	RES,M 1.5K-J-1/10
R707	ERJ6GEYJ102	RES,M 1K-J-1/10
R708	ERJ6GEYJ103	RES,M 10K-J-1/10
R709	ERDS1FJ680	RES,C 68-J-1/2W
R711	ERJ6GEYJ822	RES,M 8.2K-J-1/10
R712	ERJ6GEYJ102	RES,M 1K-J-1/10
R714	ERJ6GEYJ473	RES,M 47K-J-1/10
R715	ERJ6GEYJ103	RES,M 10K-J-1/10
R717	ERF5AK4R7	RES,W 4.7-K-5W
R718	ERJ6GEYJ102	RES,M 1K-J-1/10
R720	ERJ6GEYJ152	RES,M 1.5K-J-1/10
R787	ERQ14AJ220	RES,F 22-J-1/4W
R788	ERDS2TJ473	RES,C 47K-J-1/4
R800	ERU5TCK1R5T	RES,F 1.5-K-5W

REPLACEMENT PARTS LIST

Models: CT-32HX40B/CB & CT-36HX40B/CB

Important Safety Notice: Components printed in **BOLD TYPE** have special characteristics important for safety. When replacing any of these components use only manufacturer's specified parts.

REF NO.	PART NO.	DESCRIPTION	REF NO.	PART NO.	DESCRIPTION
R801	ERC14GK824	RES,C 820K-K-1/2W	R862	ERX12SJR22	RES,M .22-J-1/2
R803	ERDS2TJ680	RES,C 68-J-1/4	R863	ERX12SJR22	RES,M .22-J-1/2
R806	ERDS2TJ473	RES,C 47K-J-1/4	R864	ERDS2TJ101	RES,C 100-J-1/4
R807	ERDS2TJ820	RES,C 82-J-1/4	R884	ERJ6GEYJ331	RES,M 330-J-1/10
R808	ERDS2TJ680	RES,C 68-J-1/4	R885	ERJ6GEYJ102	RES,M 1K-J-1/10
R809	ERDS2TJ472	RES,C 4.7K-J-1/4	R886	ERJ6GEYJ331	RES,M 330-J-1/10
R810	ERDS2TJ473	RES,C 47K-J-1/4	R887	ERJ6GEYJ102	RES,M 1K-J-1/10
R811	ERDS2TJ472	RES,C 4.7K-J-1/4	R889	ERX3FJ5R6	RES,M 5.6-J-3W
R812	ERDS2TJ473	RES,C 47K-J-1/4	R890	ERJ6ENF30R0	RES,M 30.0-F-1/10W
R813	ERDS1FJ122	RES,C 1.2K-J-1/2	R891	ERJ6ENF5600	RES,M 560-F-1/10W
R814	ERG3FJ103H	RES,M 10K-J-3W	R894	ERJ6GEYJ102	RES,M 1K-J-1/10
R815	ERDS2TJ331	RES,C 330-J-1/4	R895	ERJ6GEYJ104	RES,M 100K-J-1/10
R816	ERDS2TJ471	RES,C 470-J-1/4	R896	ERJ6GEYJ104	RES,M 100K-J-1/10
R817	ER0S2CKF1371	RES,M 1370-F-1/4W	R902	ERDS2TJ223	RES,C 22K-J-1/4
R818	ERDS2TJ220	RES,C 22-J-1/4	R904	ERDS2TJ101	RES,C 100-J-1/4
R819	ERDS1FJ390	RES,C 39-J-1/2	R905	ERDS2TJ223	RES,C 22K-J-1/4
R820	ERDS1FJ120	RES,C 12-J-1/2	R906	ERDS2TJ472	RES,C 4.7K-J-1/4
R821	ERX12SJ1R0	RES,M 1.0-J-1/2W	R908	ERDS2TJ471	RES,C 470-J-1/4
R822	ERX12SJ1R0	RES,M 1.0-J-1/2W	R910	ERDS2TJ330	RES,C 33-J-1/4
R823	ERDS2TJ102	RES,C 1K-J-1/4	R911	ERDS2TJ330	RES,C 33-J-1/4
R824	ERDS2TJ153	RES,C 15K-J-1/4	R953	ERDS2TJ470	RES,C 47-J-1/4
R825	ERDS2TJ104	RES,C 100K-J-1/4	R954	ERDS2TJ472	RES,C 4.7K-J-1/4
R826	ERDS2TJ103	RES,C 10K-J-1/4	R955	ERDS2TJ470	RES,C 47-J-1/4
R828	ERDS2TJ103	RES,C 10K-J-1/4	R961	ERQ1CJP331	RES,F 330-J-1W
R829	ERDS2TJ473	RES,C 47K-J-1/4	R964	ERDS2FJ391	RES,C 390-J-1/4W
R830	ERDS2TJ103	RES,C 10K-J-1/4	R965	ERDS2TJ683	RES,C 68K-J-1/4
R832	ERD75TAJ825	RES,C 8.2MEG-J-3/4W	R966	ERG3FJ821H	RES,M 820-J-3W
R835	ERDS2TJ101	RES,C 100-J-1/4	R968	ERDS2FJ391	RES,C 390-J-1/4W
R836	ERDS2TJ102	RES,C 1K-J-1/4	R969	ERQ14AJ2R2	RES,F 2.2-J-1/4
R837	ERDS2TJ222	RES,C 2.2K-J-1/4	R970	ERQ14AJ2R2	RES,F 2.2-J-1/4
R838	ERG2FJ820H	RES,M 82-J-2W	R971	ERQ14AJ2R2	RES,F 2.2-J-1/4
R839	ERDS2TJ222	RES,C 2.2K-J-1/4	R972	ERQ14AJ2R2	RES,F 2.2-J-1/4
R840	ERDS2TJ470	RES,C 47-J-1/4	R975	ERDS2TJ683	RES,C 68K-J-1/4
R841	ERDS2TJ104	RES,C 100K-J-1/4	R976	ERDS2TJ100	RES,C 10-J-1/4
R842	ERDS2TJ223	RES,C 22K-J-1/4	R977	ERDS2TJ100	RES,C 10-J-1/4
R843	ERDS2TJ681	RES,C 680-J-1/4	R1051	ER0S2CKF1002	RES,M 10K-F-1/4
R844	ERDS2TJ104	RES,C 100K-J-1/4	R1052	ERDS2TJ222	RES,C 2.2K-J-1/4
R845	ERDS2TJ332	RES,C 3.3K-J-1/4	R1053	ERDS2TJ222	RES,C 2.2K-J-1/4
R846	ERDS2TJ272	RES,C 2.7K-J-1/4	R1054	ERDS2TJ332	RES,C 3.3K-J-1/4
R847	ERDS2TJ223	RES,C 22K-J-1/4	R1055	ERDS2TJ512	RES,C 5.1K-J-1/4
R850	ERDS1TJ102	RES,C 1K-J-1/2	R1056	ERDS2TJ912	RES,C 9.1K-J-1/4
R851	ERDS2TJ104	RES,C 100K-J-1/4	R1057	ERDS2TJ223	RES,C 22K-J-1/4
R852	ERDS1FJ562	RES,C 5.6K-J-1/2	R1058	ERDS2TJ103	RES,C 10K-J-1/4
R853	ERDS1FJ560	RES,C 56-J-1/2	R1059	ERDS2TJ102	RES,C 1K-J-1/4
R855	ERDS2TJ913	RES,C 91K-J-1/4	R1062	ERDS2TJ182	RES,C 1.8K-J-1/4
R856	ERDS2TJ123	RES,C 12K-J-1/4	R1063	ERDS2TJ470	RES,C 47-J-1/4
R857	ERDS1FJ1R0	RES,C 1.0-J-1/2	R1064	ERDS2TJ103	RES,C 10K-J-1/4
R858	ERDS1FJ1R0	RES,C 1.0-J-1/2	R1065	ERDS2TJ104	RES,C 100K-J-1/4
R859	ERDS2TJ103	RES,C 10K-J-1/4	R1066	ERDS2TJ473	RES,C 47K-J-1/4
R860	ERDS1FJ102	RES,C 1K-J-1/2	R1501	ERJ6GEYJ102	RES,M 1K-J-1/10
R861	ERX12SJR22	RES,M .22-J-1/2	R1503	ERJ6GEYJ222	RES,M 2.2K-J-1/10

REPLACEMENT PARTS LIST

Models: CT-32HX40B/CB & CT-36HX40B/CB

Important Safety Notice: Components printed in **BOLD TYPE** have special characteristics important for safety. When replacing any of these components use only manufacturer's specified parts.

REF NO.	PART NO.	DESCRIPTION
R1504	ERDS2TJ102	RES,C 1K-J-1/4
R1505	ERDS2TJ102	RES,C 1K-J-1/4
R1506	ERJ6GEYJ102	RES,M 1K-J-1/10
R1507	ERDS2TJ102	RES,C 1K-J-1/4
R1508	ERJ6GEYJ332	RES,M 3.3K-J-1/10
R1510	ERC12GK101	RES,S 100-K-1/2
R1511	ERDS2TJ913	RES,C 91K-J-1/4
R1512	ERDS2TJ913	RES,C 91K-J-1/4
R1513	ERDS2TJ753	RES,C 75K-J-1/4
R1521	ERDS2TJ104	RES,C 100K-J-1/4
R1522	ERDS2TJ104	RES,C 100K-J-1/4
R1523	ERDS2TJ104	RES,C 100K-J-1/4
R1525	ERDS2TJ102	RES,C 1K-J-1/4
R1526	ERDS2TJ101	RES,C 100-J-1/4
R1527	ERC14GK334	RES,C 330K-K-1/4W
R1528	ERDS2TJ473	RES,C 47K-J-1/4
R1529	ERG1SJ332P	RES,M 3300-J-1W
R1530	ERG3FJ821H	RES,M 820-J-3W
R1531	ERG3FJ821H	RES,M 820-J-3W
R1532	ERC12GK104	RES,C 100K-K-1/2W
R1533	ERDS2TJ125	RES,C 1.2MEG-J/1/4
R1534	ERDS2TJ125	RES,C 1.2MEG-J/1/4
R1535	ERDS2TJ203	RES,C 20K-J-1/4
R1536	ERG2FJ123H	RES,M 12K-J-2W
R1537	ERDS2TJ101	RES,C 100-J-1/4
R1538	ERDS2TJ103	RES,C 10K-J-1/4
R1539	ERDS2TJ103	RES,C 10K-J-1/4
R1540	ERDS2TJ560	RES,C 56-J-1/4
R2203	ERJ6GEYJ221	RES,M 220-J-1/10
R2204	ERJ6GEYJ221	RES,M 220-J-1/10
R2205	ERJ6GEYJ105	RES,M 1.0MEG-J-1/10
R2206	ERJ6GEYJ104	RES,M 100K-J-1/10
R2207	ERJ6ENF6202	RES,M 62K-F-1/10W
R2208	ERJ6GEYJ332	RES,M 3.3K-J-1/10
R2209	ERJ6GEYJ302	RES,M 3K-J-1/10
R2210	ERJ6GEYJ392	RES,M 3.9K-J-1/10
R2302	ERJ6GEYJ103	RES,M 10K-J-1/10
R2303	ERJ6GEYJ752	RES,M 7.5K-J-1/10
R2306	ERJ6GEYJ103	RES,M 10K-J-1/10
R2307	ERJ6GEYJ752	RES,M 7.5K-J-1/10
R2310	ERD25FJ2R2	RES,C 2.2-J-1/4
R2313	ERD25FJ2R2	RES,C 2.2-J-1/4
R2314	ERJ6GEYJ332	RES,M 3.3K-J-1/10
R2315	ERJ6GEYJ332	RES,M 3.3K-J-1/10
R2316	ERJ6GEYJ223	RES,M 22K-J-1/10
R2317	ERJ6GEYJ271	RES,M 270-J-1/10
R2318	ERJ6GEYJ223	RES,M 22K-J-1/10
R2319	ERJ6GEYJ102	RES,M 1K-J-1/10
R2320	ERJ6GEYJ473	RES,M 47K-J-1/10
R2321	ERJ6GEYJ223	RES,M 22K-J-1/10
R2322	ERJ6GEYJ223	RES,M 22K-J-1/10

REF NO.	PART NO.	DESCRIPTION
R2351	ERJ6GEYJ224	RES,M 220K-J-1/10
R2352	ERJ6GEYJ154	RES,M 150K-J-1/10
R2353	ERJ6GEYJ183	RES,M 18K-J-1/10
R2354	ERJ6GEYJ472	RES,M 4.7K-J-1/10
R2355	ERJ6GEYJ103	RES,M 10K-J-1/10
R2356	ERJ6GEYJ102	RES,M 1K-J-1/10
R2357	ERJ6GEYJ103	RES,M 10K-J-1/10
R2358	ERJ6GEYJ102	RES,M 1K-J-1/10
R2359	ERJ6GEYJ332	RES,M 3.3K-J-1/10
R2362	ERJ6GEYJ332	RES,M 3.3K-J-1/10
R2365	ERJ6GEYJ472	RES,M 4.7K-J-1/10
R2366	ERJ6GEYJ183	RES,M 18K-J-1/10
R2367	ERJ6GEYJ103	RES,M 10K-J-1/10
R2368	ERJ6GEYJ102	RES,M 1K-J-1/10
R2369	ERJ6GEYJ103	RES,M 10K-J-1/10
R2370	ERJ6GEYJ102	RES,M 1K-J-1/10
R2371	ERJ6GEYJ102	RES,M 1K-J-1/10
R2372	ERJ6GEYJ102	RES,M 1K-J-1/10
R2373	ERJ6GEYJ223	RES,M 22K-J-1/10
R2374	ERJ6GEYJ272	RES,M 22K-J-1/10
R2375	ERJ6GEYJ332	RES,M 22K-J-1/10
R2376	ERJ6GEYJ103	RES,M 10K-J-1/10
R2377	ERJ6GEYJ104	RES,M 100K-J-1/10
R2378	ERJ6GEYJ104	RES,M 100K-J-1/10
R2379	ERJ6GEYJ473	RES,M 47K-J-1/10
R2380	ERJ6GEYJ104	RES,M 100K-J-1/10
R2381	ERJ6GEYJ104	RES,M 100K-J-1/10
R2385	ERG1SJ181P	RES,M 180-J-1W
R2386	ERG1SJ181P	RES,M 180-J-1W
R2588	ERJ6GEYJ472	RES,M 4.7K-J-1/10
R2590	ERJ6GEYJ331	RES,M 330-J-1/10
R2598	ERJ6GEYJ101	RES,M 100-J-1/10
R2599	ERJ6GEYJ101	RES,M 100-J-1/10
R2600	ERJ6GEYJ183	RES,M 18K-J-1/10
R2602	ERJ6GEYJ274	RES,M 270K-J-1/10
R2604	ERJ6GEYJ392	RES,M 3.9K-J-1/10
R2605	ERJ6GEYJ101	RES,M 100-J-1/10
R2606	ERJ6GEYJ101	RES,M 100-J-1/10
R2609	ERJ6GEYJ684	RES,M 680K-J-1/10
R2614	ERJ6GEYJ331	RES,M 330-J-1/10
R2615	ERJ6GEYJ683	RES,M 68K-J-1/10
R2616	ERJ6GEYJ101	RES,M 100-J-1/10
R2617	ERJ6GEYJ183	RES,M 18K-J-1/10
R2618	ERJ6GEYJ101	RES,M 100-J-1/10
R2619	ERJ6GEYJ103	RES,M 10K-J-1/10
R2621	ERJ6GEYJ392	RES,M 3.9K-J-1/10
R2622	ERJ6ENF3301	RES,M 3.3K-F-1/10
R2623	ERJ6GEYJ220	RES,M 22-J-1/10
R2624	ERJ6ENF4751	RES,M 4.75K-F-1/10W
R2625	ERJ6ENF3601	RES,M 3.6K-F-1/10
R2626	ERJ6GEYJ220	RES,M 22-J-1/10

REPLACEMENT PARTS LIST

Models: CT-32HX40B/CB & CT-36HX40B/CB

Important Safety Notice: Components printed in **BOLD TYPE** have special characteristics important for safety. When replacing any of these components use only manufacturer's specified parts.

REF NO.	PART NO.	DESCRIPTION	REF NO.	PART NO.	DESCRIPTION
R2627	ERJ6GEYJ472	RES,M 4.7K-J-1/10	R3044	ERJ6GEYJ681	RES,M 680-J-1/10
R2628	ERJ6GEYJ560	RES,M 56-J-1/10	R3046	ERJ6GEYJ333	RES,M 33K-J-1/10
R2629	ERJ6GEYJ560	RES,M 56-J-1/10	R3047	ERJ6GEYJ333	RES,M 33K-J-1/10
R2630	ERJ6GEYJ560	RES,M 56-J-1/10	R3048	ERJ6GEYJ820	RES,M 82-J-1/10
R2637	ERJ6GEYJ102	RES,M 1K-J-1/10	R3051	ERJ6ENF75R0	RES,M 75.0-F-1/10W
R2638	ERJ6GEYJ102	RES,M 1K-J-1/10	R3052	ERJ6ENF75R0	RES,M 75.0-F-1/10W
R2639	ERJ6GEYJ102	RES,M 1K-J-1/10	R3053	ERJ6ENF75R0	RES,M 75.0-F-1/10W
R2640	ERJ6GEYJ100	RES,M 10-J-1/10	R3054	ERJ6GEYJ184	RES,M 180K-J-1/10
R2641	ERJ6GEYJ181	RES,M 180-J-1/10	R3055	ERJ6GEYJ184	RES,M 180K-J-1/10
R2642	ERJ6GEYJ100	RES,M 10-J-1/10	R3056	ERJ6ENF75R0	RES,M 75.0-F-1/10W
R2643	ERJ6GEYJ181	RES,M 180-J-1/10	R3057	ERJ6ENF75R0	RES,M 75.0-F-1/10W
R2644	ERJ6GEYJ100	RES,M 10-J-1/10	R3058	ERJ6ENF75R0	RES,M 75.0-F-1/10W
R2645	ERJ6GEYJ181	RES,M 180-J-1/10	R3059	ERJ6GEYJ184	RES,M 180K-J-1/10
R2646	ERJ6GEYJ100	RES,M 10-J-1/10	R3060	ERJ6GEYJ184	RES,M 180K-J-1/10
R2647	ERJ6GEYJ100	RES,M 10-J-1/10	R3063	ERJ6GEYJ820	RES,M 82-J-1/10
R2648	ERJ6GEYJ100	RES,M 10-J-1/10	R3070	ERJ6ENF75R0	RES,M 75.0-F-1/10W
R2649	ERJ6GEYJ472	RES,M 4.7K-J-1/10	R3071	ERJ6ENF75R0	RES,M 75.0-F-1/10W
R2660	ERJ6GEYJ362	RES,M 3.6K-J-1/10	R3072	ERJ6GEYJ103	RES,M 10K-J-1/10
R2699	ERJ6GEYJ473	RES,M 47K-J-1/10	R3073	ERJ6ENF75R0	RES,M 75.0-F-1/10W
R2700	ERJ6GEYJ272	RES,M 2.7K-J-1/10	R3074	ERJ6GEYJ184	RES,M 180K-J-1/10
R2701	ERJ6GEYJ103	RES,M 10K-J-1/10	R3075	ERJ6GEYJ184	RES,M 180K-J-1/10
R2702	ERJ6GEYJ183	RES,M 18K-J-1/10	R3076	ERJ6ENF75R0	RES,M 75.0-F-1/10W
R2711	ERJ6GEYJ362	RES,M 3.6K-J-1/10	R3077	ERJ6ENF75R0	RES,M 75.0-F-1/10W
R2712	ERJ6GEYJ102	RES,M 1K-J-1/10	R3078	ERJ6GEYJ103	RES,M 10K-J-1/10
R3001	ERJ6GEYJ820	RES,M 82-J-1/10	R3079	ERJ6ENF75R0	RES,M 75.0-F-1/10W
R3006	ERJ6GEYJ820	RES,M 82-J-1/10	R3080	ERJ6GEYJ184	RES,M 180K-J-1/10
R3011	ERJ6GEYJ820	RES,M 82-J-1/10	R3081	ERJ6GEYJ184	RES,M 180K-J-1/10
R3016	ERJ6GEYJ820	RES,M 82-J-1/10	R3082	ERJ6GEYJ184	RES,M 180K-J-1/10
R3020	ERJ6GEYJ331	RES,M 330-J-1/10	R3083	ERJ6GEYJ184	RES,M 180K-J-1/10
R3021	ERJ6GEYJ680	RES,M 68-J-1/10	R3084	ERJ6GEYJ680	RES,M 68-J-1/10
R3022	ERJ6GEYJ681	RES,M 680-J-1/10	R3085	ERJ6ENF75R0	RES,M 75.0-F-1/10W
R3023	ERJ6GEYJ331	RES,M 330-J-1/10	R3086	ERJ6GEYJ102	RES,M 1K-J-1/10
R3024	ERJ6GEYJ101	RES,M 100-J-1/10	R3087	ERJ6GEYJ102	RES,M 1K-J-1/10
R3025	ERJ6GEYJ681	RES,M 680-J-1/10	R3100	ERJ6GEYJ221	RES,M 220-J-1/10
R3026	ERJ6GEYJ331	RES,M 330-J-1/10	R3101	ERJ6GEYJ221	RES,M 220-J-1/10
R3027	ERJ6GEYJ101	RES,M 100-J-1/10	R3102	ERJ6GEYJ221	RES,M 220-J-1/10
R3028	ERJ6GEYJ681	RES,M 680-J-1/10	R3103	ERJ6GEYJ102	RES,M 1K-J-1/10
R3030	ERJ6GEYJ331	RES,M 330-J-1/10	R3104	ERJ6GEYJ221	RES,M 220-J-1/10
R3031	ERJ6GEYJ101	RES,M 100-J-1/10	R3105	ERJ6GEYJ221	RES,M 220-J-1/10
R3032	ERJ6GEYJ681	RES,M 680-J-1/10	R3106	ERJ6GEYJ221	RES,M 220-J-1/10
R3033	ERJ6GEYJ331	RES,M 330-J-1/10	R3107	ERJ6GEYJ221	RES,M 220-J-1/10
R3034	ERJ6GEYJ101	RES,M 100-J-1/10	R3108	ERJ6GEYJ221	RES,M 220-J-1/10
R3035	ERJ6GEYJ681	RES,M 680-J-1/10	R3109	ERJ6GEYJ221	RES,M 220-J-1/10
R3036	ERJ6GEYJ331	RES,M 330-J-1/10	R3110	ERJ6GEYJ221	RES,M 220-J-1/10
R3037	ERJ6GEYJ101	RES,M 100-J-1/10	R3114	ERJ6GEYJ221	RES,M 220-J-1/10
R3038	ERJ6GEYJ681	RES,M 680-J-1/10	R3115	ERJ6GEYJ221	RES,M 220-J-1/10
R3039	ERJ6GEYJ331	RES,M 330-J-1/10	R3116	ERJ6GEYJ221	RES,M 220-J-1/10
R3040	ERJ6GEYJ331	RES,M 330-J-1/10	R3117	ERJ6GEYJ221	RES,M 220-J-1/10
R3041	ERJ6GEYJ471	RES,M 470-J-1/10	R3118	ERJ6GEYJ221	RES,M 220-J-1/10
R3042	ERJ6GEYJ681	RES,M 680-J-1/10	R3119	ERJ6GEYJ221	RES,M 220-J-1/10
R3043	ERJ6GEYJ681	RES,M 680-J-1/10	R3120	ERJ6GEYJ221	RES,M 220-J-1/10

REPLACEMENT PARTS LIST

Models: CT-32HX40B/CB & CT-36HX40B/CB

Important Safety Notice: Components printed in **BOLD TYPE** have special characteristics important for safety. When replacing any of these components use only manufacturer's specified parts.

REF NO.	PART NO.	DESCRIPTION
R3121	ERJ6GEYJ221	RES,M 220-J-1/10
R3122	ERJ6GEYJ221	RES,M 220-J-1/10
R3123	ERJ6GEYJ221	RES,M 220-J-1/10
R3124	ERJ6GEYJ221	RES,M 220-J-1/10
R3125	ERJ6GEYJ221	RES,M 220-J-1/10
R3126	ERJ6GEYJ221	RES,M 220-J-1/10
R3127	ERJ6GEYJ221	RES,M 220-J-1/10
R3128	ERJ6GEYJ221	RES,M 220-J-1/10
R3129	ERJ6GEYJ221	RES,M 220-J-1/10
R3130	ERJ6GEYJ221	RES,M 220-J-1/10
R3131	ERJ6GEYJ221	RES,M 220-J-1/10
R3132	ERJ6GEYJ221	RES,M 220-J-1/10
R3140	ERJ6GEYJ221	RES,M 220-J-1/10
R3141	ERJ6GEYJ221	RES,M 220-J-1/10
R3145	ERJ6GEYJ333	RES,M 33K-J-1/10
R3146	ERJ6GEYJ103	RES,M 1.5K-J-1/10
R3147	ERJ6ENF75R0	RES,M 75.0-F-1/10W
R3148	ERJ6ENF75R0	RES,M 75.0-F-1/10W
R3149	ERJ6ENF75R0	RES,M 75.0-F-1/10W
R3152	ERDS2TJ224	RES,C 220K-J-1/4
R3154	ERDS2TJ224	RES,C 220K-J-1/4
R3211	ERJ6GEYJ152	RES,M 1.5K-J-1/10
R3212	ERJ6GEYJ152	RES,M 1.5K-J-1/10
R3213	ERJ6GEYJ331	RES,M 330-J-1/10
R3214	ERJ6GEYJ152	RES,M 1.5K-J-1/10
R3215	ERJ6GEYJ152	RES,M 1.5K-J-1/10
R3216	ERJ6GEYJ331	RES,M 330-J-1/10
R3217	ERJ6GEYJ101	RES,M 100-J-1/10
R3218	ERJ6GEYJ101	RES,M 100-J-1/10
R3219	ERJ6GEYJ221	RES,M 220-J-1/10
R3220	ERJ6GEYJ221	RES,M 220-J-1/10
R3221	ERJ6GEYJ820	RES,M 82-J-1/10
R3222	ERJ6GEYJ102	RES,M 1K-J-1/10
R3223	ERJ6GEYJ221	RES,M 220-J-1/10
R3224	ERJ6GEYJ820	RES,M 82-J-1/10
R3225	ERJ6GEYJ102	RES,M 1K-J-1/10
R3226	ERJ6GEYJ221	RES,M 220-J-1/10
R3227	ERJ6GEYJ820	RES,M 82-J-1/10
R3228	ERJ6GEYJ102	RES,M 1K-J-1/10
R3230	ERJ6GEYJ221	RES,M 220-J-1/10
R3231	ERJ6GEYJ680	RES,M 68-J-1/10
R3232	ERJ6GEYJ102	RES,M 1K-J-1/10
R3233	ERJ6GEYJ221	RES,M 220-J-1/10
R3234	ERJ6GEYJ820	RES,M 82-J-1/10
R3235	ERJ6GEYJ102	RES,M 1K-J-1/10
R3236	ERJ6GEYJ221	RES,M 220-J-1/10
R3237	ERJ6GEYJ820	RES,M 82-J-1/10
R3238	ERJ6GEYJ102	RES,M 1K-J-1/10
R3801	ER0S2CKF9100	RES,M 910-F-1/4W
R3802	ERDS2TJ122	RES,C 1.2K-J-1/4
R3803	ERG3FJ393H	RES,M 39K-J-3W

REF NO.	PART NO.	DESCRIPTION
R3805	ERDS2TJ822	RES,C 8.2K-J-1/4
R3808	ERDS2TJ332	RES,C 3.3K-J-1/4
R3809	ERC12GK471	RES,C 470-K-1/2W
R3811	ER0S2CKF9100	RES,M 910-F-1/4W
R3812	ERDS2TJ122	RES,C 1.2K-J-1/4
R3813	ERG3FJ393H	RES,M 39K-J-3W
R3815	ERDS2TJ562	RES,C 5.6K-J-1/4
R3818	ERDS2TJ102	RES,C 1K-J-1/4
R3819	ERC12GK471	RES,C 470-K-1/2W
R3821	ER0S2CKF9100	RES,M 910-F-1/4W
R3822	ERDS2TJ122	RES,C 1.2K-J-1/4
R3823	ERG3FJ393H	RES,M 390-J-3W
R3825	ERDS2TJ822	RES,C 8.2K-J-1/4
R3828	ERDS2TJ122	RES,C 1.2K-J-1/4
R3829	ERC12GK471	RES,C 470-K-1/2W
R3830	ER0S2CKF2702	RES,M 27K-F-1/4
R3831	ER0S2CKF1372	RES,M 13.7K-F-1/4W
R3837	ERDS2TJ103	RES,C 10K-J-1/4
R3838	ERDS2TJ563	RES,C 56K-J-1/4
R5001	ERDS2TJ472	RES,C 4.7K-J-1/4
R5003	ERX12SJ2R7	RES,M 2.7-J-1/2W
R5004	ERDS2TJ272	RES,C 2.7K-J-1/4
R5005	ER0S2CKF1331	RES,M 1.33-F-1/4W
R5006	ER0S2CKF3320	RES,M 332-F-1/4W
R5007	ER0S2CKF1001	RES,M 1K-F-1/4
R5008	ER0S2CKF3832	RES,M 38.3K-F-1/4
R5009	ER0S2CKF9091	RES,M 9.09K-F-1/4W
R5010	ER0S2CKF2213	RES,M 221K-F-1/4
R5011	ER0S2CKF5491	RES,M 5.49K-F-1/4W
R5012	ER0S2CKF2701	RES,M 2.7K-F-1/4W
R5014	ERDS1FJ180	RES,C 18-J-1/2
R519A	ERQ1CKPR22	RES,F .22-K-1W
R6505	ERJ6GEYJ104	RES,M 100K-J-1/10
R6526	ERJ6GEYJ102	RES,M 1K-J-1/10
R6527	ERJ6GEYJ102	RES,M 1K-J-1/10
R6528	ERJ6GEYJ101	RES,M 100-J-1/10
R6529	ERJ6GEYJ221	RES,M 220-J-1/10
R6530	ERJ6GEYJ332	RES,M 3.3K-J-1/10
R6532	ERJ6GEYJ333	RES,M 33K-J-1/10
R6533	ERJ6GEYJ123	RES,M 12K-J-1/10
R6535	ERJ6GEYJ153	RES,M 15K-J-1/10
R6539	ERJ6GEYJ513	RES,M 51K-J-1/10
R6540	ERJ6GEYJ303	RES,M 30K-J-1/10
R6541	ERJ6GEYJ393	RES,M 39K-J-1/10
R6542	ERJ6GEYJ332	RES,M 3.3K-J-1/10
R6543	ERJ6GEYJ332	RES,M 3.3K-J-1/10
R6544	ERJ6GEYJ222	RES,M 2.2K-J-1/10
R6546	ERJ6GEYJ332	RES,M 3.3K-J-1/10
R6547	ERJ6GEYJ222	RES,M 2.2K-J-1/10
R6548	ERJ6GEYJ101	RES,M 100-J-1/10
R6549	ERJ6GEYJ221	RES,M 220-J-1/10

REPLACEMENT PARTS LIST

Models: CT-32HX40B/CB & CT-36HX40B/CB

Important Safety Notice: Components printed in **BOLD TYPE** have special characteristics important for safety. When replacing any of these components use only manufacturer's specified parts.

REF NO.	PART NO.	DESCRIPTION	REF NO.	PART NO.	DESCRIPTION
R6550	ERJ6GEYJ220	RES,M 22-J-1/10	M014	TJS59036	PHONO PIN L TYPE CT-32HX40B, CT-32HX40CB
R6551	ERJ6GEYJ220	RES,M 22-J-1/10	M015	TMW2A97121	STRAIN RELIEF: AC LINE CORD
R6552	ERJ6GEYJ334	RES,M 330K-J-1/10	M016	TQB2AA0337-1	OWNERS MANUAL CT-32HX40B CT-36HX40CB
R6554	ERJ6GEYJ331	RES,M 330-J-1/10	M017	TQB2AA0360-1	OWNERS MANUAL CT-36HX40CB CT-32HX40CB
R6555	ERJ6GEYJ822	RES,M 8.2K-J-1/10	M018	TQB2AA7065	REMOTE GUIDE
R6556	ERJ6ENF1002	RES,M 10K-F-1/10	M019	TQB2AA7076	V-CHIP ROLLER GUIDE CT-32HX40B, CT-32HX40CB, CT-36HX40CB
R6557	ERJ6ENF3001	RES,M 3K-F-1/10	M020	TXANV03BSER	ASSY, FRONT PANEL CT-36HX40B, CT-36HX40CB
R6560	ERJ6GEYJ471	RES,M 470-J-1/10	M021	TXANV04BSER	ASSY, COIL DEGAUSSING CT-36HX40B, CT-36HX40CB
R6563	ERJ6GEYJ221	RES,M 220-J-1/10	M027	TXANV11BSER	ASSY, COIL DEGAUSSING CT-32HX40B, CT-32HX40CB
R6564	ERJ6GEYJ101	RES,M 100-J-1/10	M022	TXANV05BSER	2 EXTENSION CABLES (35 pins & 25 pins)
R6565	ERJ6GEYJ102	RES,M 1K-J-1/10	M023	TXANV06BSER	3 EXTENSION CABLES (13 pins)
R6567	ERJ6GEYJ472	RES,M 4.7K-J-1/10	M024	TXANV07BSER	4 EXTENSION CABLES (8 pins)
R6568	ERJ6GEYJ472	RES,M 4.7K-J-1/10	M025	TXANV09BSER	ASSY, GEO-COIL CT-36HX40B, CT-36HX40CB
R6569	ERJ6GEYJ472	RES,M 4.7K-J-1/10	M028	TXANV12BSER	ASSY, GEO-COIL CT-32HX40B, CT-32HX40CB
R6576	ERJ6GEYJ221	RES,M 220-J-1/10	M026	TXANV10BSER	ASSY, FRONT PANEL CT-32HX40B, CT-32HX40CB
SWITCHES			M029	TXFBX16BSER	ASSY, POWER BUTTON
S001	EVQPF106K	SWITCH	M031	TXANV18BSER	CRT KIT
S002	EVQPBD05R	SWITCH	M033	TXFKU51BSER	ASSY, CABINET BACK CT-32HX40B, CT-32HX40CB
S003	EVQPBD05R	SWITCH	M034	TXFKU52BSER	ASSY, CABINET BACK CT-36HX40B, CT-36HX40CB
S004	EVQPBD05R	SWITCH	M035	TXFKY28BSER	ASSY, CABINET FRONT COMPLETE CT-32HX40B, CT-32HX40CB
S005	EVQPBD05R	SWITCH	M036	TXFKY29BSER	ASSY, CABINET FRONT COMPLETE CT-36HX40B, CT-36HX40CB
S006	EVQPBD05R	SWITCH	M037	TXFSPB01BSER	ASSY, SPEAKER BRACKET CT-36HX40B, CT-36HX40CB
S007	EVQPBD05R	SWITCH	M038	TXFSPB02BSER	ASSY, SPEAKER BRACKET CT-32HX40B, CT-32HX40CB
TRANSFORMERS			M039	UR51EC892-4	BATTERY COVER, REMOTE CONTROL
T501	ETH19K186AM	TRANSFORMER	M040	0FMK014ZZ	CONVERGENCE CORRECTOR STRIP
T551	KFT5AV289F	TRANSFORMER, FLYBACK	JK3001	TJB2AA0251	TERMINAL, REAR A/V 12P
T801	ETS49KL125AG	TRANSFORMER	JK3004	TJB2AA0241	TERMINAL, REAR A/V 10P
T802	ETP30KB921GG	TRANSFORMER	JK3151	TJBA187	TERMINAL, A/V
T1501	ETF18L101A	TRANSFORMER			
CRYSTALS/FILTERS					
X001	TSSA096	CRYSTAL			
X6501	TSSA114	CRYSTAL			
X6502	TSSJ024	CRYSTAL			
OTHERS					
M001	TNPA1669S	ASSY, DG-PANEL NON-SERVICABLE			
M002	A90LSW195X	CRT 36 CT-36HX40B, CT-36HX40CB			
M006	M80LSW195X	CRT 32 CT-32HX40B, CT-32HX40CB			
DY	KDY43HB50F	DEFLECTION YOKE CT-32HX40B, CT-32HXCB			
DY	KDY45HB49F	DEFLECTION YOKE CT-36HX40B, CT-36HXCB			
TNR001	ENG36602G	1st TUNER (Main)			
TNR002	ENG36603G	2nd TUNER (Sub)			
M003	EAGG1218N2	SPEAKER, DOME			
M004	ENPE630	2RF SPLITTER			
M005	EUR511158	REMOTE CONTROL			
M007	TBM2AA0024	BADGE, PANASONIC			
M008	TBM2AC0281	OVERLAY			
M010	TEK6940	DOOR CATCH			
M011	TJSC01800	CRT SOCKET			
M013	TJS2AX0061	SPEAKER TERMINAL			

NOTES:

1. RESISTOR

All resistors are carbon 1/4W resistor, unless otherwise noted by the following marks.
Unit of resistance is ohm (Ω), (K=1,000, M=1,000,000)

<input type="radio"/>	Non Flammable	<input type="triangle"/>	Solid
<input checked="" type="checkbox"/>	Metal Oxide	<input type="circle"/>	Metal (Precision and high stability)
<input type="checkbox"/>	Wire Wound	<input type="checkbox"/>	Thermistor
<input checked="" type="checkbox"/>	Fusible	<input type="checkbox"/>	Positive coefficient Thermistor
<input checked="" type="checkbox"/>	Flame Proof Rectangular		

2. CAPACITOR

All capacitors are ceramic 50V capacitor, unless otherwise noted by the following marks.
Unit of capacitance is μF , unless otherwise noted.

<input checked="" type="checkbox"/>	Electrolytic	<input checked="" type="checkbox"/>	Metalized Polyester
<input type="circle"/>	Tantalum	<input type="circle"/>	Polypropylene
NP	Bipolar	<input type="triangle"/>	Mica
<input type="circle"/>	Polystyrene	<input type="circle"/>	Ceramic
<input checked="" type="checkbox"/>	Temperature Compensation	<input type="circle"/>	Ceramic (SL)
<input type="circle"/>	Polyester		

3. COIL

Unit of inductance is μH , unless otherwise noted.

4. VOLTAGE MEASUREMENT

Voltage is measured by a digital meter receiving normal signal.

Note: *These schematic diagrams are the latest at the time of printing and are subject to change without notice.*

SERVICE NOTES:

This model has section that does not share a common ground with the power supply section. The different sections are referred to as HOT section and COLD section in the precautions below.

1. Do not touch the HOT section and the COLD section at the same time. You may receive an electric shock.
2. Do not short the HOT section to the COLD section. This could blow the fuse or damage parts.
3. Never measure the HOT section and the COLD section at the same time when using tools such as oscilloscopes or multimeters.
4. Always unplug the unit before beginning any operation such as removing the chassis.

Connection Diagram

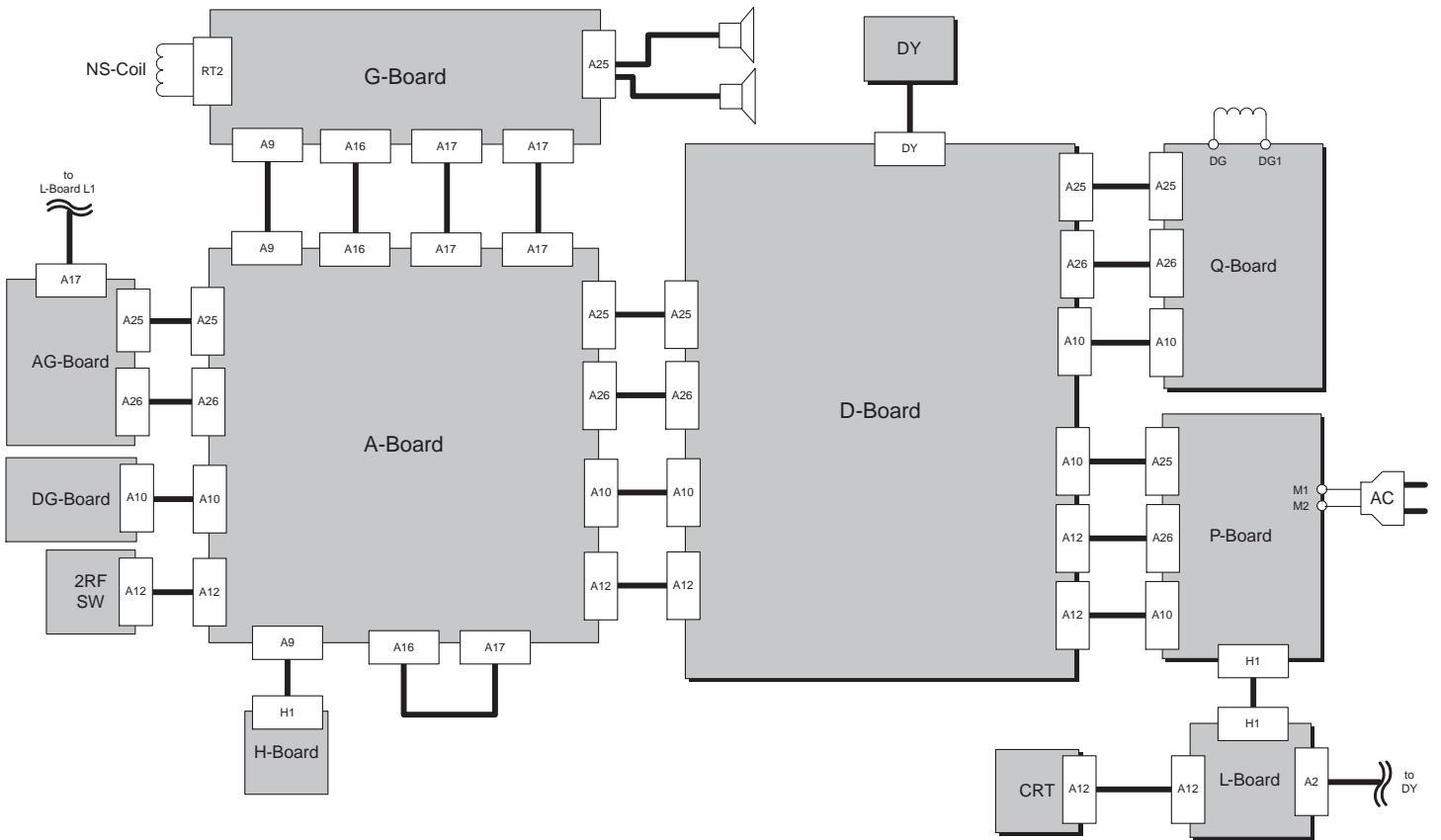

Connector's Description

P4-L3 Description 1 +B2 2 NC 3 210V 4 NC 5 HEATER 6 NC 7 H.GND	A4-D4 Description 1 AUDIO 30/35V 2 AUDIO 30/35V 3 AUDIO GND 4 AUDIO GND 5 ZERO X DET 6 STBY 7V 7 STBY 7V 8 SIGNAL GND 9 AC ON/OFF 10 DEG ON/OFF 11 +B ON/OFF 12 STB PS 13 STB PS GND 14 SIGNAL GND 15 30V 16 SIGNAL GND	D8-Q8 Description 1 144V 2 NC 3 PCC D 4 NC 5 PCC DRIVE 6 12V 7 FBP 8 INNER PIN 9 EW DRIVE 10 VL 11 VH 12 VH 13 VH	D6-A6 Description 1 VP2 2 H DRIVE GC 3 FBP 4 NC 5 V DRIVE GC 6 GND IIC 7 EW DRIVE 8 GND IIC 9 SOS 10 VL 11 SDA2 12 H GND 13 SCL2 14 H GND 15 H GND 16 VL	D9-Q9 Description 1 GND 2 UNREG -15 3 UNREG 15V 4 +B ON/OFF 5 VP 6 HHS DET 7 H DRIVE GC 8 V GND 9 V DAF 10 5V 11 9V 12 MOMENT +B 13 DOWN 14 V DRIVE GC	D10-Q10 Description 1 RASTER ADJ 2 NC 3 GND 4 H DRIVE 5 HDNTSC 6 FOCUS 7 SOS 8 HEATER FOR 9 HHS 10 FB T EHT 11 NC 12 GND IIC 13 SCL2 14 SDA2	D7-A7 Description 1 TUNER GND 2 TUNER GND 3 ABL 4 NC 5 V DAF 6 H DAF 7 R OUT 8 (2) SP GND 9 (2) SP GND 10 L OUT	G3-A3 Description 1 NC 2 L4 3 NC 4 R4 5 GND 6 NC 7 R OUT 8 (2) SP GND 9 (2) SP GND 10 L OUT	G2-A2 Description 1 GND 2 NC 3 NC 4 GEO MAG (NS) 5 GND 6 NC 7 NC 8 GND 9 S4 10 NC	G1-A1 Description 1 NC 2 RMT 3 KEY1 4 KEY2 5 GND 6 GND 7 5V 8 3V 9 12V 10 GND	P1-D1 Description 1 +B2 2 NC 3 210V 4 NC 5 HEATER 6 H GND 7 TUNER GND 8 TUNER GND	A26-AG26 Description 1 5V 2 9V 3 VL NECK PRO 4 SDA2 5 SCL2 6 DTV VD2 7 DTV HD2 8 NTSC VD2 9 NTSC HD2 10 SUB V/Y 11 SUB C/Pb 12 MAIN V/Y 13 MAIN C/Pb 14 FSC 15 MAIN Pr 16 MAIN GND 17 COMB Y 18 COMB C 19 COMB Y 20 COMB C 21 OSD R 22 OSD G 23 OSD B 24 OSD B 25 12V 26 OSD GND 27 Pr 28 TP47B 29 Pb 30 TP47G 31 Y 32 TP47G 33 Y 34 TP47R 35 VPO1 36 CLP	A25-AG25 Description 1 TP246 2 VIDEO MUTE 3 VIDEO MUTE 4 VM 5 YS 6 BLOOMING DD 7 H/V BLK 8 GND 9 S/VIDEO SW 10 DTV1 Pr 11 DTV1 Y 12 DTV1 GND 13 DTV2 Pr 14 DTV2 Pb 15 DTV2 Y 16 DTV2 GND 17 MAIN Pr 18 MAIN Pr 19 MAIN C/Pb 20 MAIN V/Y 21 MAIN GND 22 SUB Pr 23 SUB C/Pb 24 SUB V/Y 25 SUB GND	A19-AG2 Description 1 ABL 2 VIDEO MUTE 3 GND 4 YM 5 YS 6 GND 7 VM 8 V GND 9 BLOOMING DC 10 H DRIVE 11 VP2 12 V GND 13 DI 14 H/V BLK 15 GND 16 S/VIDEO SW 17 SUB COMP 18 GND 19 NC 20 HFP 21 GND 22 NC 23 NC 24 GND 25 V DAF 26 V DRIVE 27 FBP 28 EW DRIVE 29 GND 30 GND 31 GND 32 EHT DET 33 H DAF 34 GND 35 D 3.3V 36 D 3.3V 37 GND 38 9V 39 D 3.3V 40 D 3.3V 41 GND	A19-AG2 Description 42 GND 43 NC 44 5V 45 5V 46 GND 47 SDA2 48 SCL2 49 DTV VD2 50 DTV HD2 51 NTSC VD2 52 NTSC HD2 53 GND 54 SUB V/Y 55 GND 56 SUB C/Pb 57 GND 58 SUB Pr 59 SUB GND 60 MAIN V/Y 61 GND 62 MAIN C/Pb 63 GND 64 MAIN Pr 65 GND 66 FSC 67 COMB C 68 COMB Y 69 COMB GND 70 OSD R 71 OSD G 72 OSD B 73 OSD GND 74 Pr 75 TP221 76 Pb 77 NC 78 Y 79 NC 80 TP224 81 CLP 82 GND	A15 Description 1 SDA2 2 SCL2 3 FA2(GND) 4 SCL1 5 NC 6 TPB2 7 SDA1 8 FA1	A12-2RF Description 1 9V 2 RF SW	A19-AG2 Description 1 GND 2 GND	G5-A13 Description 1 AV4 V 2 AV4 GND 3 AV4 Y 4 AV4 C	G1-P1 Description 1 +B 2 NC 3 210V 4 NC 5 HEATER 6 GND 7 TUNER GND 8 TUNER GND	L1-AG1 Description 1 VM 2 GND 3 R 4 G 5 B 6 GND 7 12V 8 GND	P12-D12 Description 1 HOT GND 2 HOT GND 3 HOT GND 4 HOT GND 5 HOT GND 6 HOT GND 7 HOT GND 8 HOT GND	P11-D11 Description 1 170VDC 2 170VDC 3 170VDC 4 170VDC 5 170VDC 6 170VDC 7 170VDC 8 170VDC	L1-AG1 Description 1 DTV1 Pr 2 DTV1 Pb 3 DTV1 Y 4 DTV1 GND 5 DTV2 Pr 6 DTV2 Pb 7 DTV2 Y 8 DTV2 GND 9 MAIN Pr 10 MAIN C/Pb 11 MAIN Y 12 MAIN GND 13 SUB Pr 14 SUB Pb 15 SUB Y 16 SUB GND 17 SCL 1 18 SDA 1 19 9V 20 VAO R 21 VAO L 22 MAIN R 23 MAIN L 24 MAIN C 25 DOLBY C 26 NC GND 27 TV1 V 28 TV1 L 29 TV1 R 30 S2 4C4 31 S4 32 Y4 33 L4 34 V4 35 R4
--	--	---	---	---	---	--	--	--	--	--	--	---	---	---	---	---	--	---	---	--	--	--	---

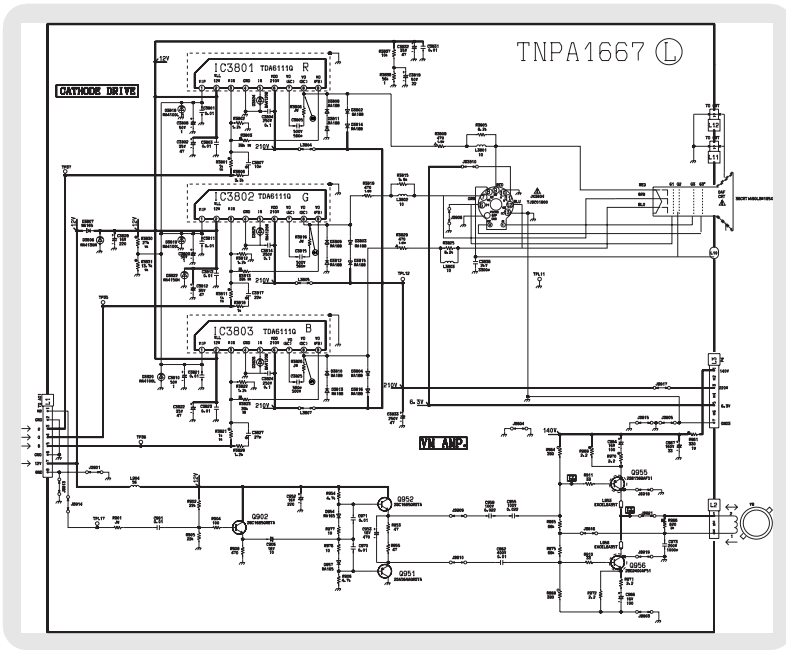

L-Board Voltage Measurements
(IC & Transistors)

	Q951	Q952	Q955	IC3801	IC3802	IC3803
B	5.26	6.52	141.5	1 ... 3.51	1 ... 3.51	1 ... 3.51
C	0.00	11.80	77.80	2 ... 11.08	2 ... 11.80	2 ... 11.80
E	5.85	5.94	141.80	3 ... 3.46	3 ... 3.47	3 ... 3.46
				4 ... 0.00	4 ... 0.00	4 ... 0.00
				5 ... 6.30	5 ... 6.97	5 ... 6.84
				6 ... 220.50	6 ... 220.50	6 ... 220.50
B	0.44	5.46		7 ... 134.60	7 ... 138.00	7 ... 138.20
C	77.90	11.80		8 ... 136.10	8 ... 139.60	8 ... 139.60
E	0.00	4.80		9 ... 133.60	9 ... 136.90	9 ... 137.00

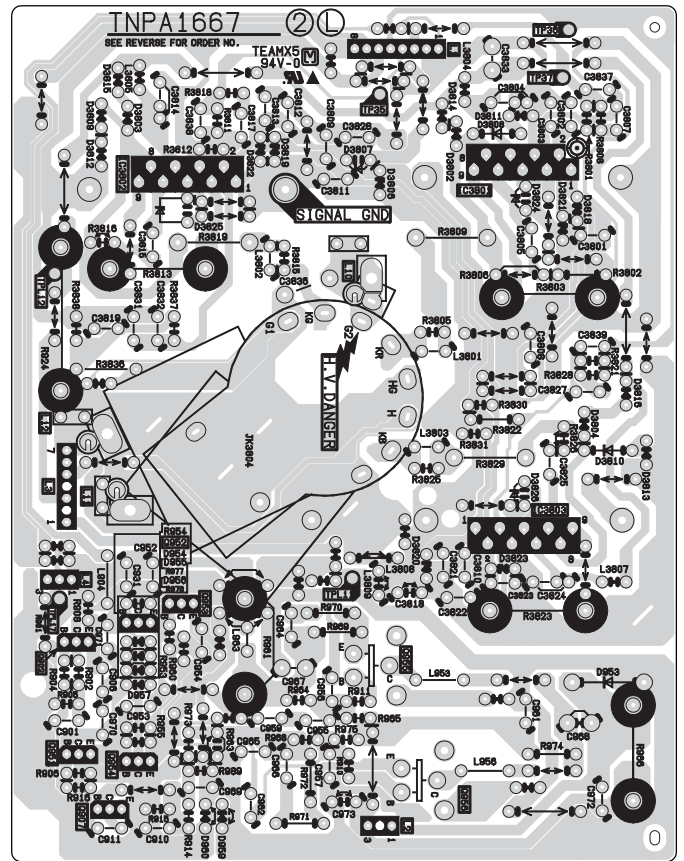

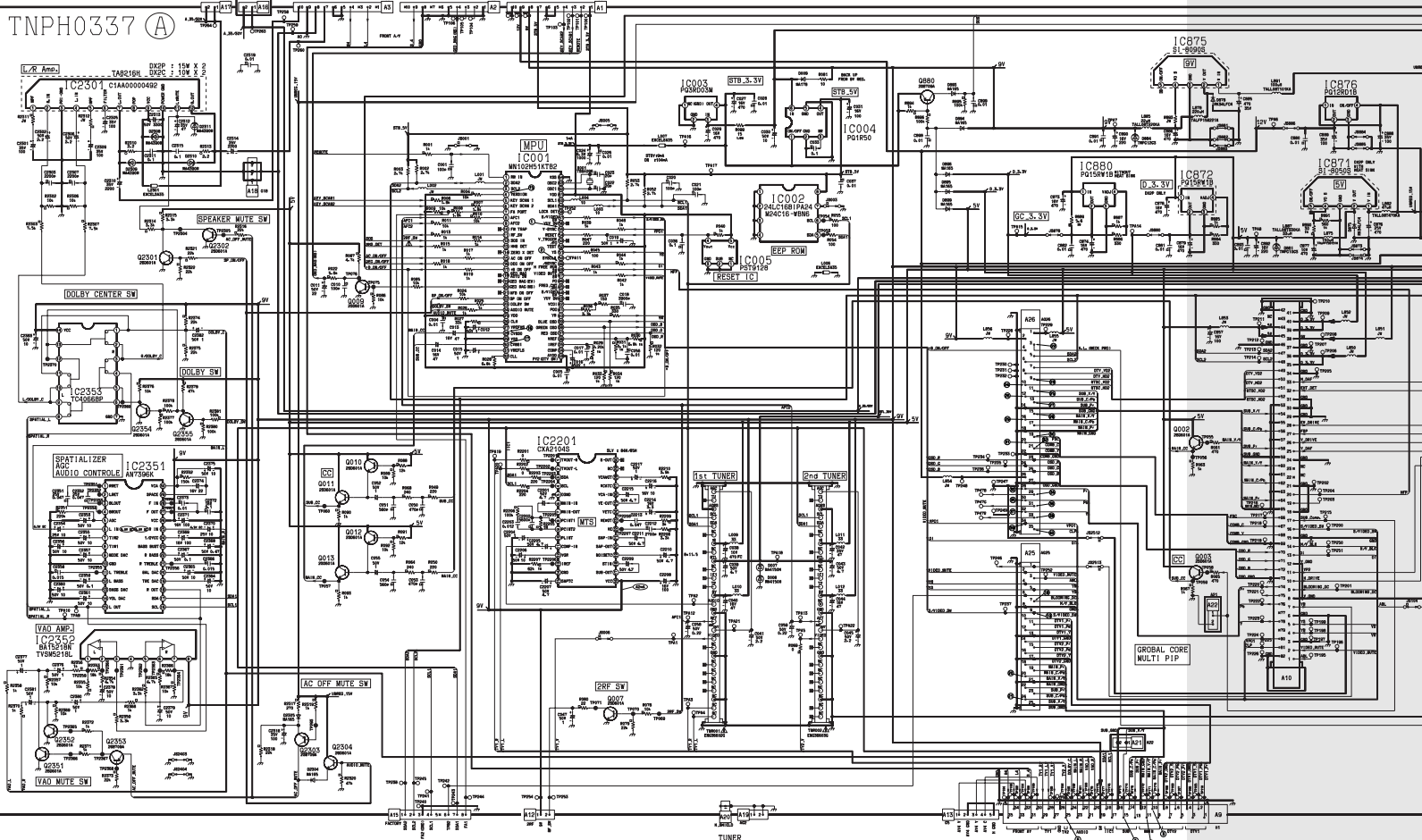

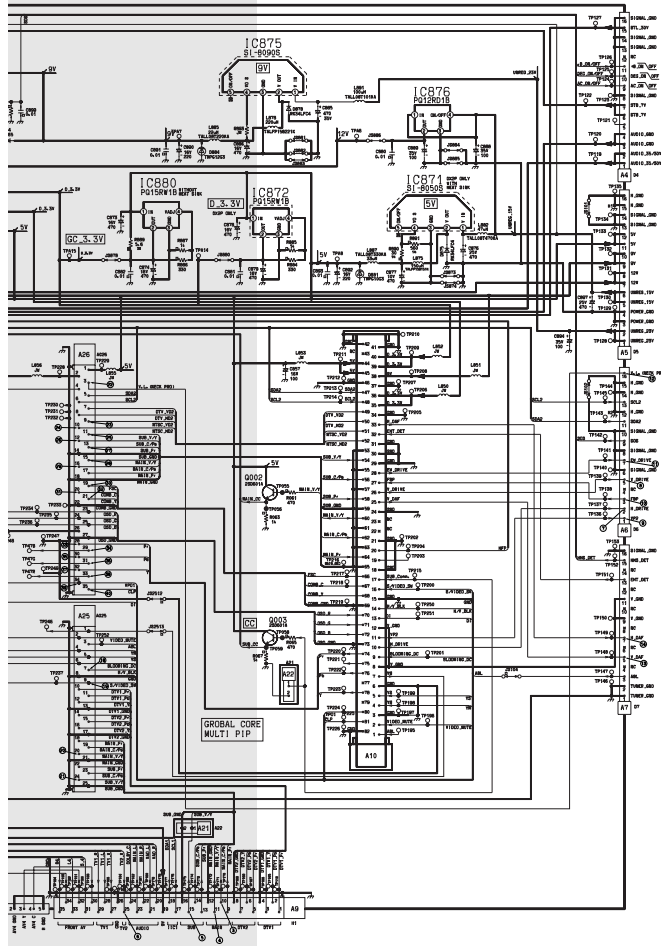

A-Board Voltage Measurements
(IC & Transistors)

IC001			IC002			IC871			IC2201			IC2351			IC2352		
1	0.00	3.28	1	0.00	0.00	1	14.66	1	4.05	1	4.45	1	4.45	1	4.41		
2	2.77	2.06	2	0.00	0.00	2	5.43	2	4.05	2	4.45	2	4.45	2	4.41		
3	3.07	1.37	3	0.00	0.00	3	0.00	3	4.67	3	4.43	3	4.43	3	4.41		
4	3.28	1.39	4	0.00	0.00	4	4.93	4	4.70	4	4.49	4	4.49	4	0.00		
5	3.28	0.00	5	4.62	0.00	5	0.00	5	0.00	5	1.30	5	1.30	5	4.44		
6	3.28	0.00	6	4.70	0.00	6	0.00	6	4.04	6	4.43	6	4.43	6	4.44		
7	3.28	0.00	7	0.00	0.00	7	0.00	7	4.00	7	0.50	7	0.50	7	4.44		
8	1.72	0.00	8	5.00	0.00	8	5.00	8	4.05	8	0.65	8	0.65	8	8.88		
9	1.60	1.46	9	0.00	0.00	9	4.91	9	3.88	9	1.72	9	1.72	9	0.00		
10	0.00	1.46	10	0.00	0.00	10	3.51	10	5.21	10	0.00	10	0.00	10	0.00		
11	3.19	0.00	11	0.00	0.00	11	0.00	11	4.03	11	4.43	11	4.43	11	4.43		
12	0.00	0.00	12	0.00	0.00	12	2.64	12	1.25	12	4.45	12	4.45	12	4.45		
13	0.00	0.00	13	0.00	0.00	13	0.00	13	1.24	13	2.00	13	2.00	13	4.41		
14	0.00	0.00	14	5.65	0.00	14	0.00	14	0.00	14	2.78	14	2.78	14	4.41		
15	3.14	0.00	15	3.29	0.00	15	26.41	15	4.40	15	4.41	15	4.41	15	4.43		
16	0.00	3.26	16	0.00	0.00	16	9.19	16	0.00	16	4.70	16	4.70	16	8.91		
17	0.00	0.33	17	0.00	0.00	17	0.00	17	4.66	17	4.44	17	4.44	17	8.91		
18	0.00	1.64	18	0.00	0.00	18	0.00	18	4.44	18	4.44	18	4.44	18	0.00		
19	0.00	0.00	19	0.00	0.00	19	3.29	19	2.18	19	2.18	19	2.18	19	4.41		
20	0.49	3.29	20	0.00	0.00	20	1.24	20	0.00	20	2.55	20	2.55	20	4.39		
21	0.00	0.00	21	0.00	0.00	21	5.00	21	0.00	21	4.44	21	4.44	21	4.39		
22	0.00	3.28	22	0.00	0.00	22	0.00	22	0.00	22	4.45	22	4.45	22	4.46		
23	3.22	0.00	23	0.00	0.00	23	14.76	23	1.53	23	4.47	23	4.47	23	0.00		
24	0.00	0.00	24	0.00	0.00	24	11.86	24	11.15	24	4.45	24	4.45	24	0.00		
25	3.29	0.00	25	0.00	0.00	25	0.00	25	15.45	25	4.43	25	4.43	25	0.00		
26	2.08	0.00	26	0.00	0.00	26	0.00	26	5.04	26	8.88	26	8.88	26	0.00		
27	2.40	4.68	27	0.00	0.00	27	14.76	27	32.94	27	4.49	27	4.49	27	0.00		
28	1.48	4.68	28	0.00	0.00	28	0.00	28	0.00	28	4.43	28	4.43	28	0.00		
29	0.00	3.29	29	0.00	0.00	29	4.95	29	5.04	29	2.67	29	2.67	29	0.00		
30	1.51	1.64	30	0.00	0.00	30	3.52	30	15.06	30	2.66	30	2.66	30	0.00		
31	2.40	1.67	31	0.00	0.00	31	0.00	31	0.00	31	0.00	31	0.00	31	0.00		
32	1.49	0.00	32	0.00	0.00	32	3.29	32	0.00	32	0.00	32	0.00	32	0.00		

	Q002	Q003	Q007	Q009	Q010	Q011
B	3.35	3.61	0.72	0.20	2.26	2.68
C	5.01	4.91	0.17	2.81	5.04	5.04
E	2.70	2.98	0.80	0.00	2.68	2.04

	Q012	Q013	Q080	Q2301	Q2302	Q2303
B	2.26	2.64	3.29	0.00	0.00	14.28
C	5.03	5.03	0.00	5.04	5.04	0.00
E	2.64	2.64	3.29	0.00	0.00	14.02

	Q2304	Q2351	Q2352	Q2353	Q2354	Q2355
B	0.00	0.00	0.00	0.00	0.00	0.59
C	14.78	0.00	0.00	0.00	8.91	0.00
E	0.00	0.00	0.00	0.00	0.00	0.00

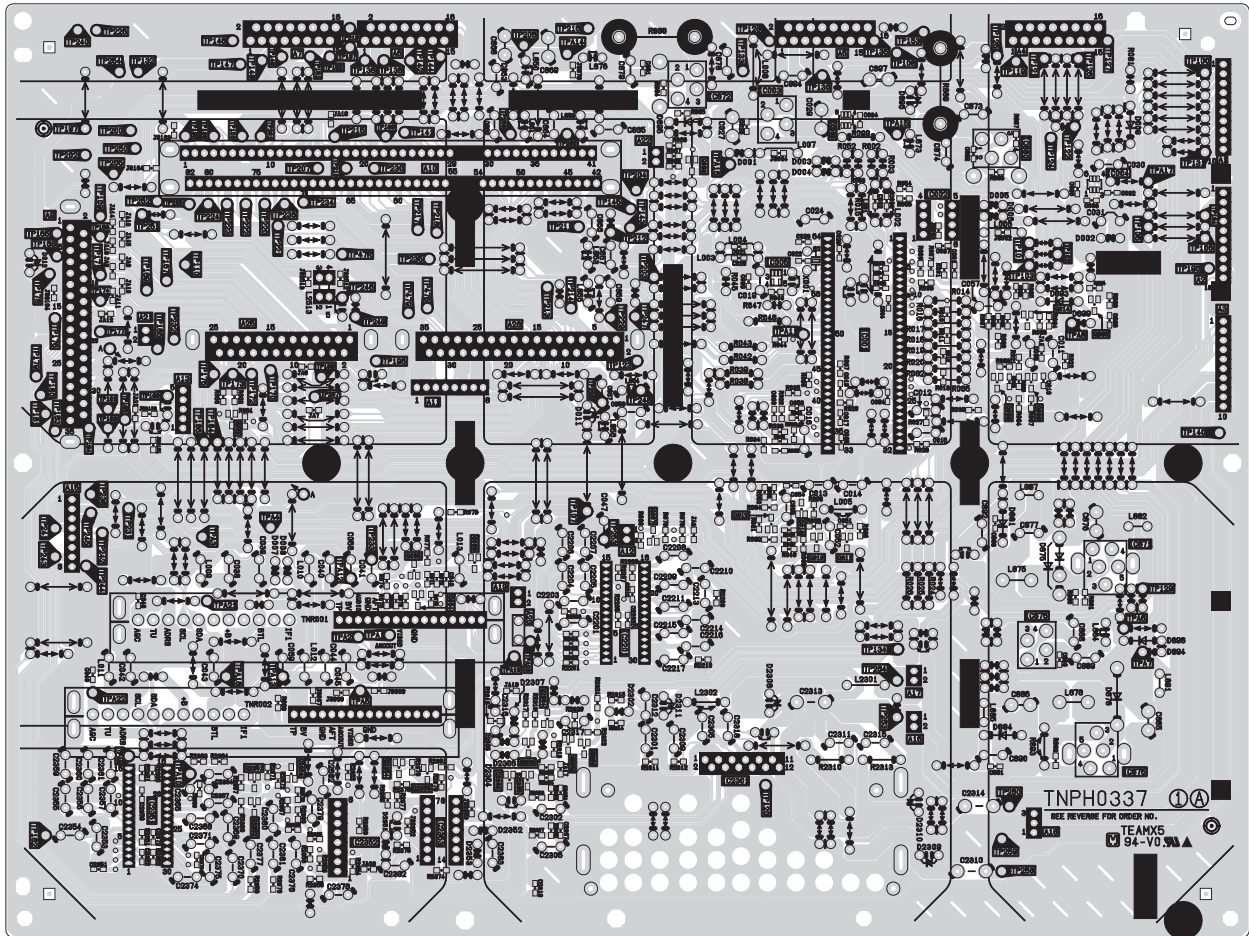

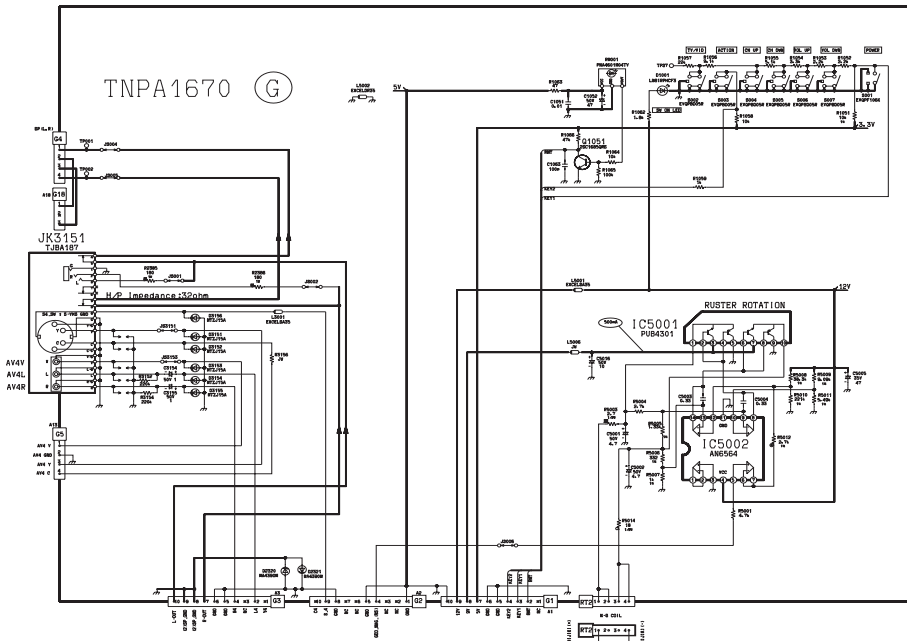

G-Board Voltage Measurements(IC & Transistors)

IC5001		IC5002		Q1051	
1	4.39	1	0.00	B	0.63
2	3.96	2	0.00	C	0.00
3	8.87	3	0.00	E	0.00
4	3.96	4	11.86		
5	0.00	5	2.82		
6	5.06	6	2.82		
7	8.87	7	2.82		
8	5.06	8	3.96		
9	0.00	9	4.46		
10	4.49	10	4.46		
		11	0.00		
		12	3.37		
		13	3.37		
		14	5.06		

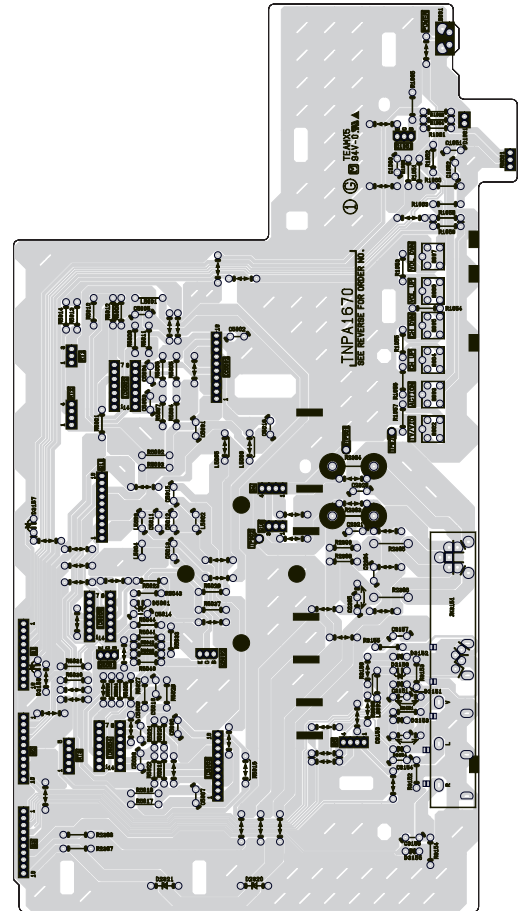

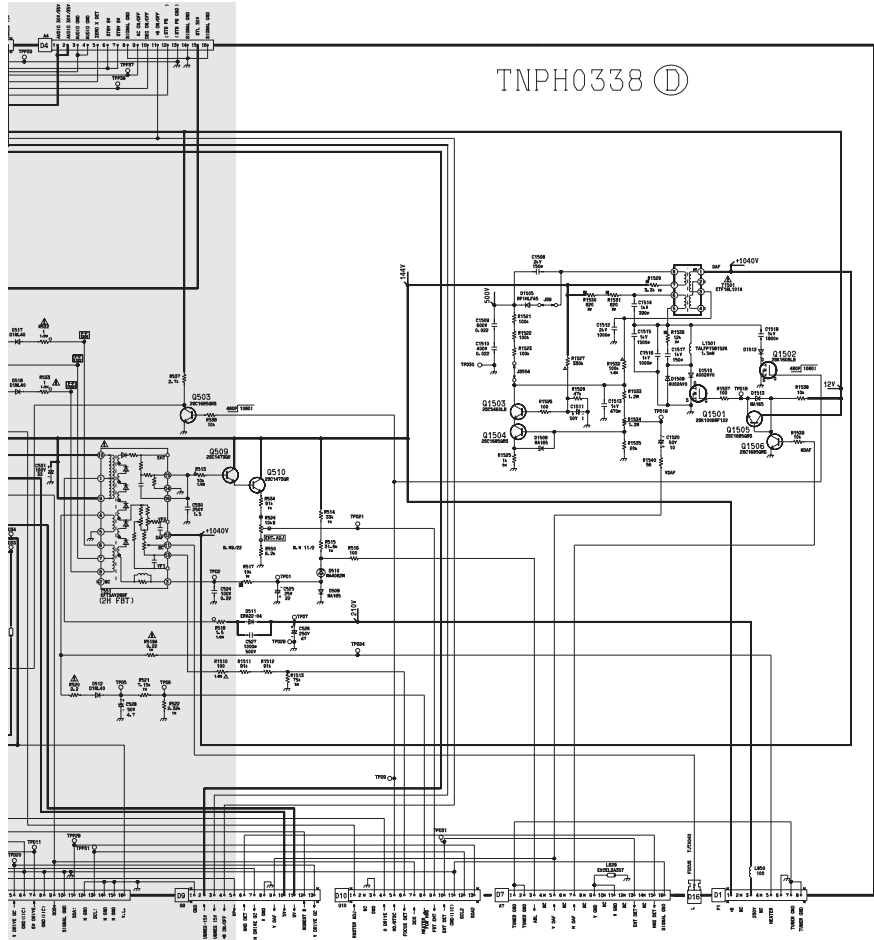

D-Board Voltage Measurements
(IC & Transistors)

IC752		IC802		IC803	
1	11.85	1	129.70	1	0.14
2	5.32	2	11.95	2	0.00
3	0.00	3	0.00	3	129.70
4	0.00			4	143.80
5	0.00	IC500		IC811	
6	27.34	1	141.80	1	13.02
7	32.66	2	141.80	2	12.03
8	39.67	3	144.10	3	5.47
IC801		4	144.10	4	5.35
1	5.43	5	137.90		
2	5.40	6	0.00		
3	5.40	7	144.10		
4	5.42	8	150.00		
5	5.20	9	149.70		
6	5.43	10	150.60		
7	5.06				
8	5.28				
9	5.14				

	Q804	Q854	Q806	Q805	Q509	Q510
B	26.69	143.10	0.00	0.69	46.58	52.00
C	0.00	0.00	2.29	0.10	143.00	143.10
E	26.94	143.50	0.00	0.00	51.90	51.50

	Q1503	Q503	Q1506	Q1504	Q551
B	18.98	0.00	0.51	1.47	0.00
C	188.20	11.85	2.93	18.43	-182.30
E	18.42	0.00	0.00	0.86	0.00

	Q751	Q755	Q502	Q1501	Q1502	Q501
S	0.00	27.36	0.00	0.00	0.00	0.00
D	-0.51	28.06	0.00	119.20	251.70	8.92
G	9.78	32.68	11.85	3.02	0.00	1.85

	Q801
S	5.20
D	0.93
G	5.42

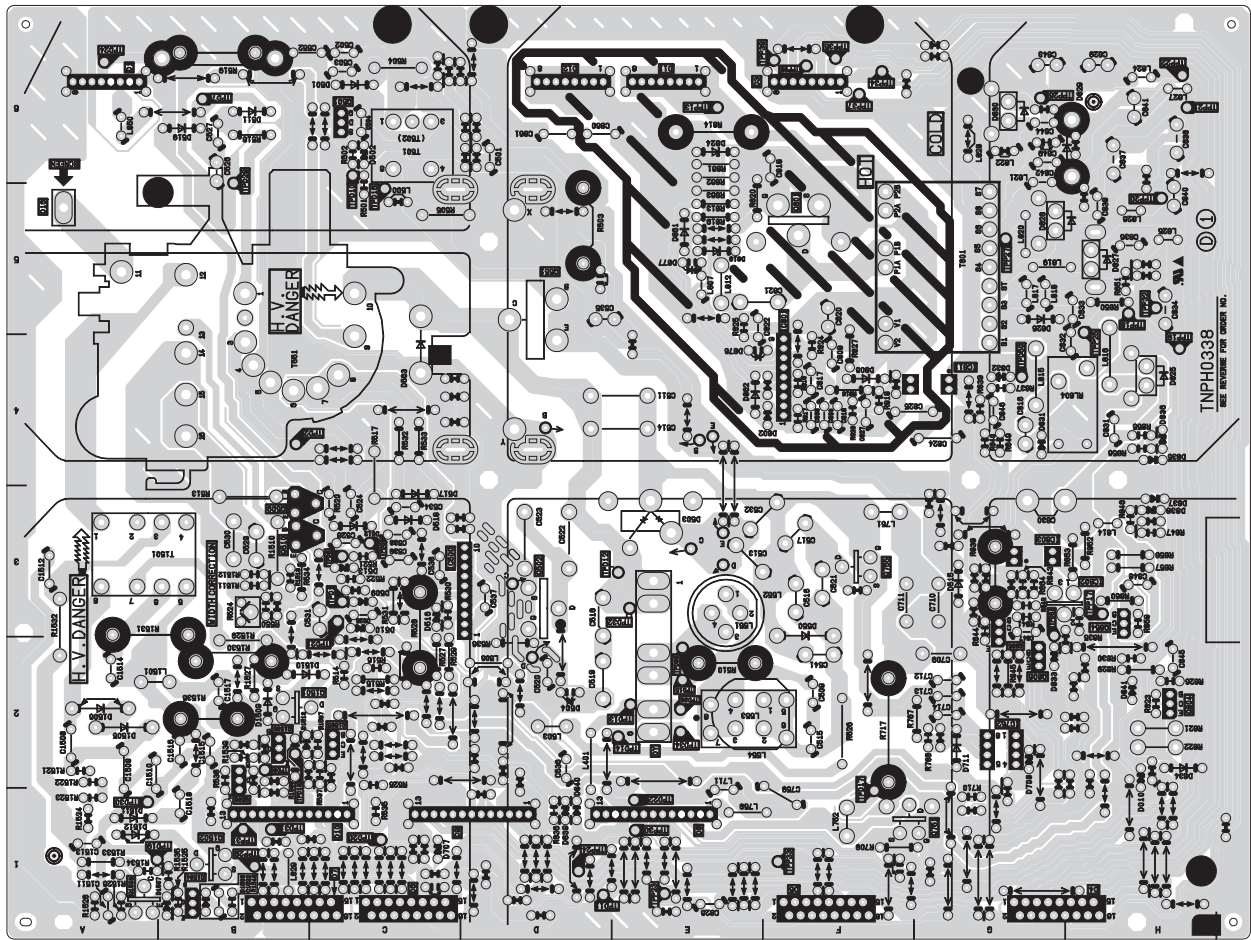

P-Board Schematic & Voltages

CT-32HX40B/CB & CT-36HX40B/CB

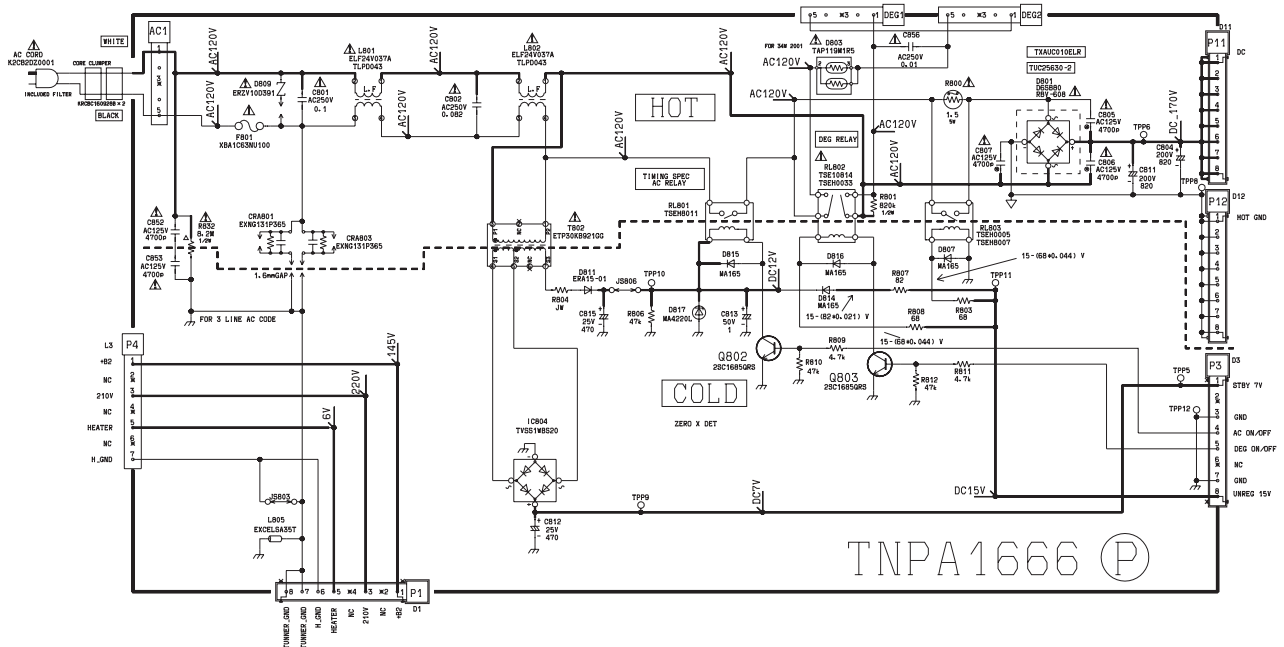

TNPA1666 (P)

P-Board Voltage Measurements (IC & Transistors)

IC804	
1	2.96
2	3.20
3	7.06
4	0.00

	Q802	Q803
B	0.73	0.00
C	0.10	15.10
E	0.00	0.00

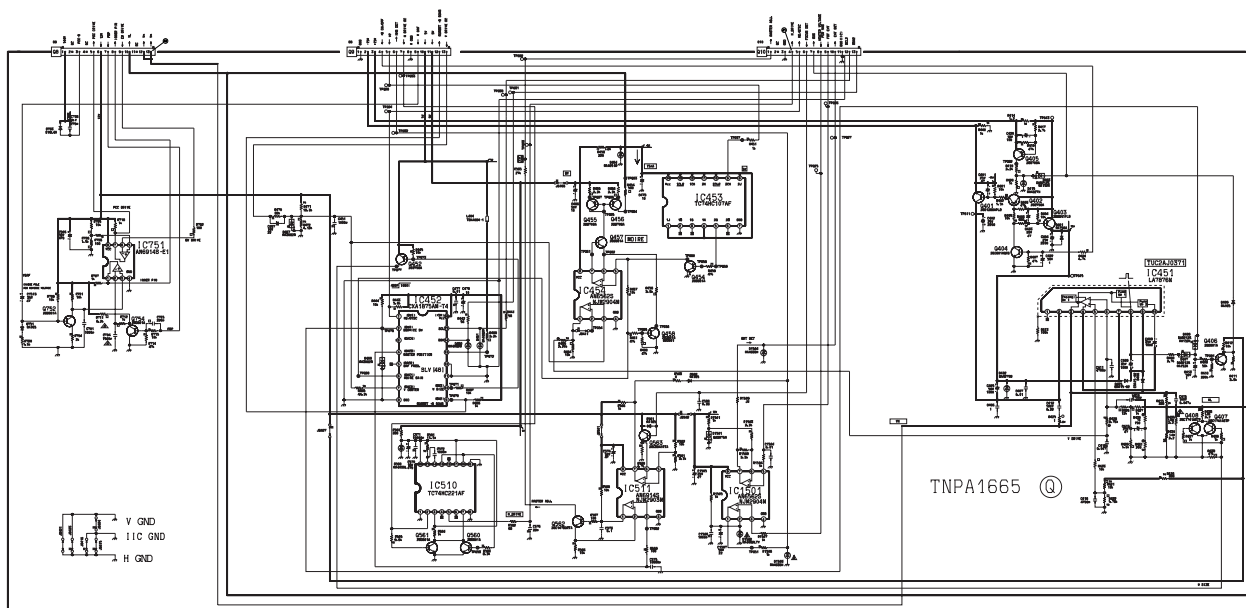

Q-Board Voltage Measurements (IC & Transistors)

IC451		Q754	Q752	Q403	Q401	Q402	Q404	Q405	Q407	Q408	Q562
1	0.10	0.00	0.23	0.29	0.20	0.28	0.00	0.11	0.10	0.00	0.00
2	0.23	0.00	1.10	0.31	0.22	0.28	0.00	0.00	0.13	0.00	0.12
3	10.21	0.00	0.22	0.28	0.19	0.28	0.00	0.10	0.00	0.13	0.00
4	7.20										
5	***										
6	0.00										
7	0.30	Q563	Q560	Q561	Q452	Q406	Q457	Q456	Q458	Q454	Q455
8	3.97	0.29	0.00	0.00	0.00	0.00	1.32	0.77	0.00	0.30	0.79
9	3.97	0.00	0.00	0.00	0.00	0.00	0.78	0.57	0.00	1.25	0.79
10	7.26	0.16	0.00	0.00	0.00	0.00	1.25	0.69	0.00	0.00	0.69

P-Board Layout

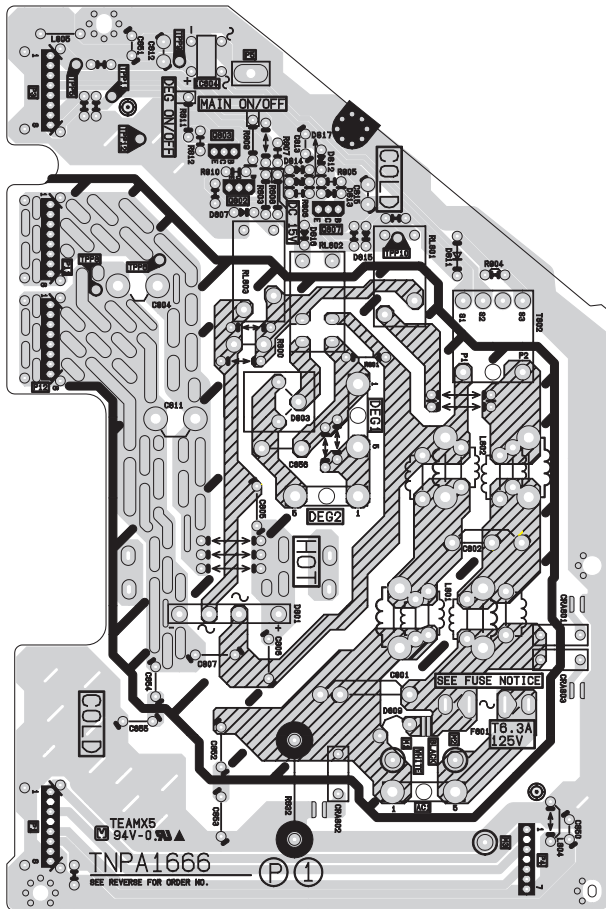

Q-Board Layout

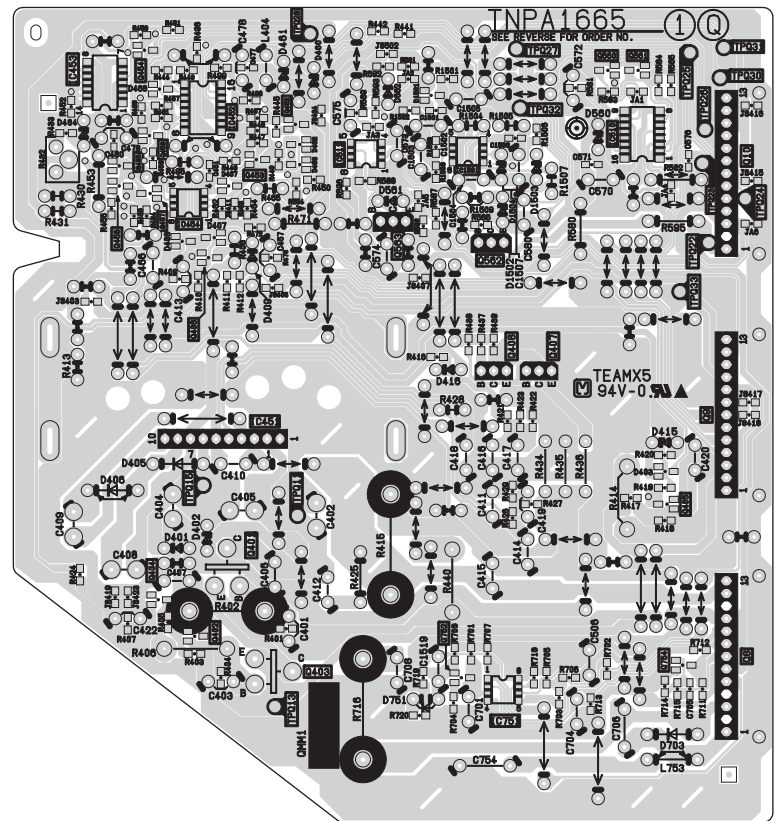

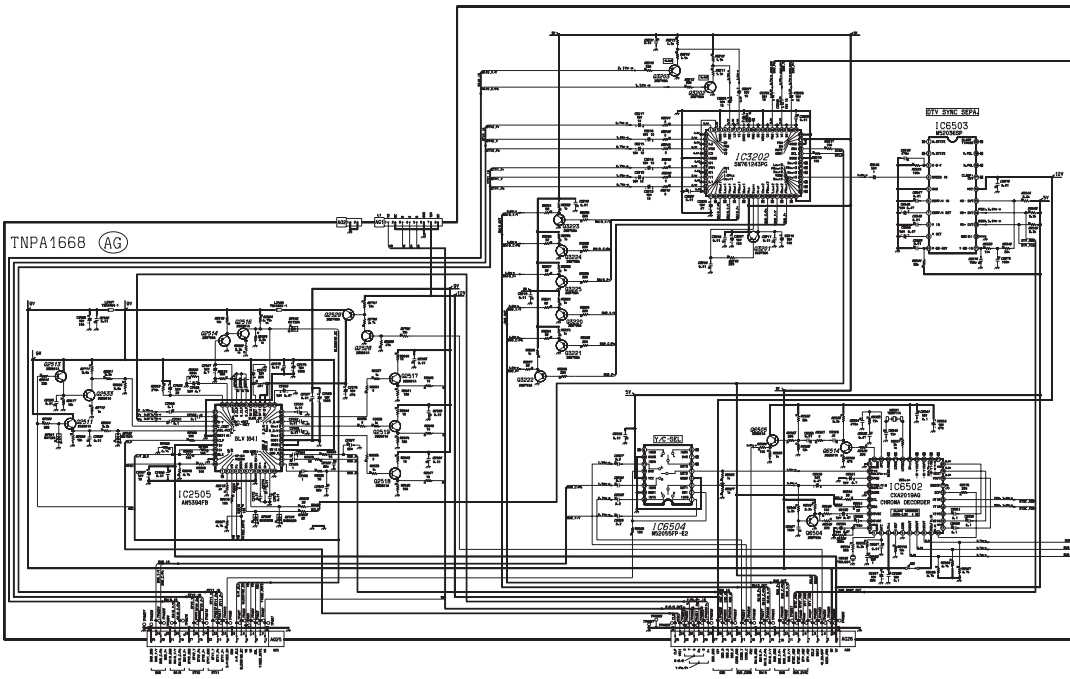

AG-Board Voltage Measurements
(IC & Transistors)

IC6503	
1	0.00
2	0.00
3	4.00
4	4.00
5	0.00
6	6.15
7	6.04
8	6.17
9	6.05
10	1.75
11	0.15
12	0.00
13	0.00
14	1.21
15	0.00
16	11.85
17	0.00
18	0.00
19	0.00
20	3.41

B C E	Q2513	Q2514	Q2516	Q2517	Q2518
	6.53	1.73	2.36	4.07	3.97
	8.85	0.00	3.57	8.66	8.67
	5.86	2.36	1.76	3.42	3.30
B C E	Q2528	Q2519	Q2529	Q2533	Q3201
	0.64	3.91	8.06	5.89	8.12
	0.10	8.67	8.78	5.14	6.46
	0.00	3.26	8.85	5.14	8.83
B C E	Q3203	Q3202	Q3220	Q3221	Q3222
	3.44	3.57	2.72	2.71	2.72
	0.00	0.00	0.00	0.00	0.00
	4.08	4.22	3.36	3.36	3.38
B C E	Q3223	Q3224	Q3225	Q6504	Q6505
	2.72	2.72	2.72	1.48	2.30
	0.00	0.00	0.00	0.00	8.84
	3.37	3.38	3.37	2.13	1.91
B C E	Q6514	Q2511			
	1.48	6.53			
	2.33	8.95			
	0.80	5.94			

H-Board Schematic & Voltages

CT-32HX40B/CB & CT-36HX40B/CB

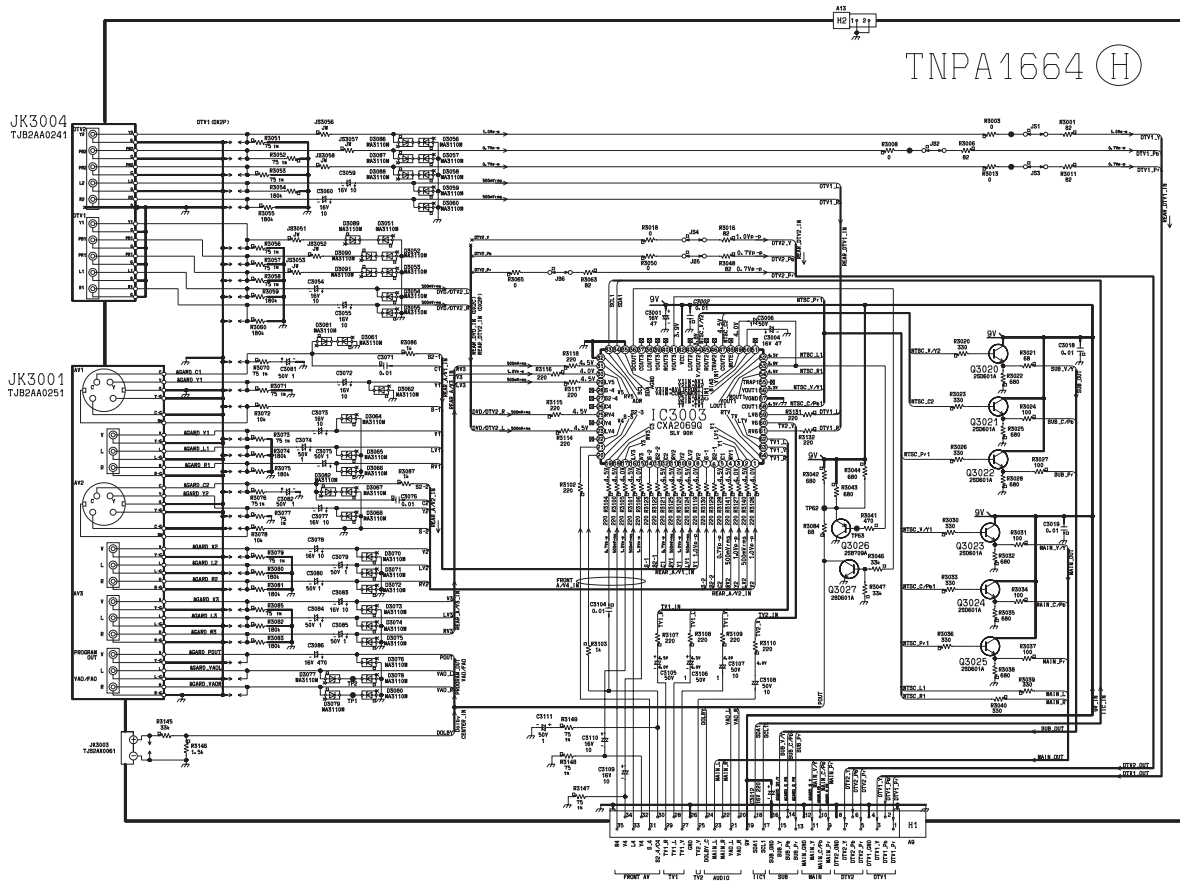

H-Board Voltage Measurements (IC & Transistors)

B	Q3020	Q3021
C	4.24	4.30
E	8.80	8.80
	3.57	3.64
B	Q3022	Q3023
C	3.54	4.10
E	8.80	8.80
	2.69	3.43
B	Q3024	Q3025
C	4.22	3.54
E	8.80	8.80
	3.57	2.89
B	Q3026	Q3027
C	4.37	0.00
E	0.00	5.05
	5.05	0.00

H-Board Layout

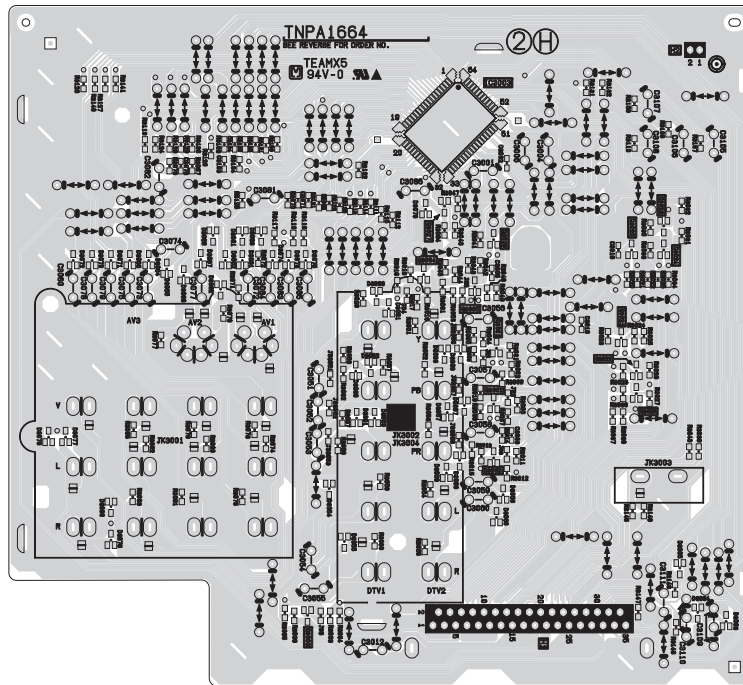

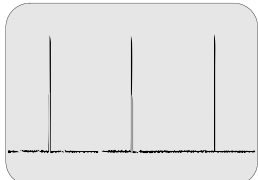

① A-Board
IC001 Pin 55 - 3.28V_{p-p}
V-SYNC

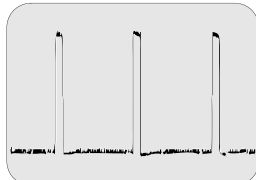

② A-Board
IC001 Pin 49 - 3.56V_{p-p}
H-SYNC



③ A-Board
A9 Pin 10 - 0.856V_{p-p}
MAIN C/Pb

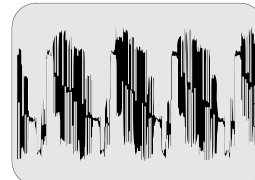

④ A-Board
A9 Pin 11 - 2.10V_{p-p}
MAIN Y

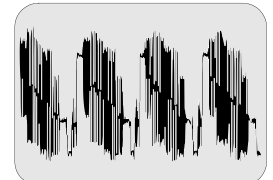

⑤ A-Board
A9 Pin 15 - 2.11V_{p-p}
SUB Y

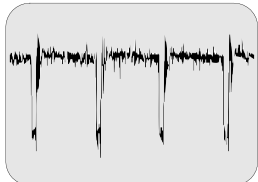

⑥ A-Board
A9 Pin 25 - 0.43V_{p-p}
TV2 V

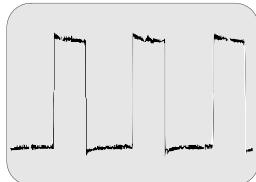

⑦ A-Board
A6 Pin 2 - 3.52V_{p-p}
H-DRIVE

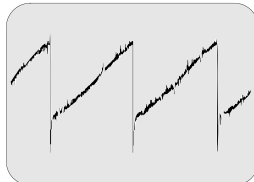

⑧ A-Board
A6 Pin 5 - 1.32V_{p-p}
V-DRIVE

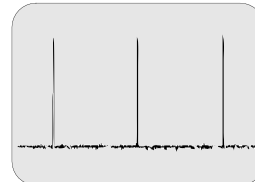

⑨ A-Board
A6 Pin 1 - 3.44V_{p-p}
VP2

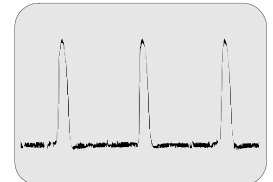

⑩ A-Board
A6 Pin 3 - 2.88V_{p-p}
FBP

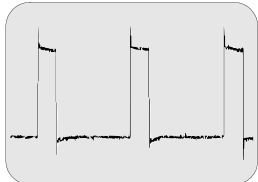

⑪ A-Board
A6 Pin 7 - 5.16V_{p-p}
EW-DRIVE

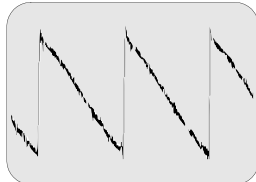

⑫ A-Board
A6 Pin 16 - 1.86V_{p-p}
V.L. (NECH PRO)

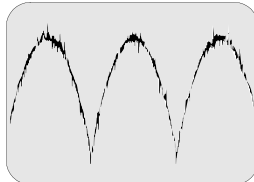

⑬ A-Board
A7 Pin 5 - 0.85V_{p-p}
V-DAF

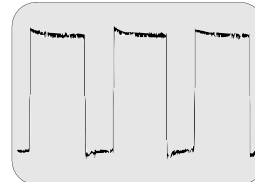

⑭ A-Board
A7 Pin 7 - 3.64V_{p-p}
H-DAF

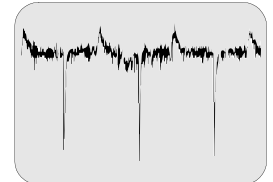

⑮ A-Board
IC001 Pin 4 - 0.33V_{p-p}
VERSION

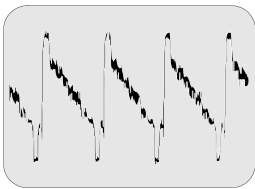

①⑥ A-Bboard
IC001 Pin 28 - 1.86V_{p-p}
CVBS0

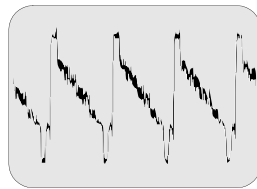

①⑦ A-Bboard
IC001 Pin 30 - 1.86V_{p-p}
CVBS1

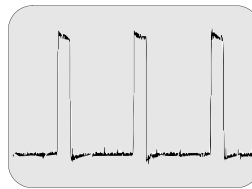

①⑧ A-Bboard
A25 Pin 7 - 3.48V_{p-p}
H/V BLK

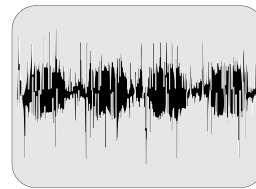

①⑨ A-Bboard
A25 Pin 9 - 0.24V_{p-p}
S/VIDEO SW

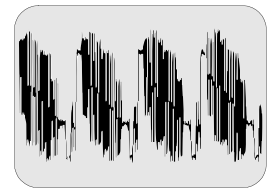

②⑩ A-Bboard
A25 Pin 20 - 2.08V_{p-p}
MAIN V/Y

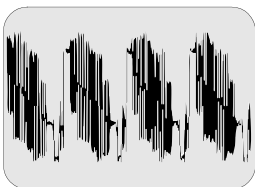

②① A-Bboard
A25 Pin 24 - 2.08V_{p-p}
SUB V/Y

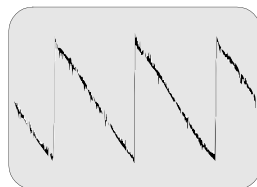

②② A-Bboard
A26 Pin 3 - 1.86V_{p-p}
NECK PRO

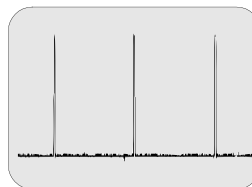

②③ A-Bboard
A26 Pin 9 - 4.72V_{p-p}
NTSC-VD2

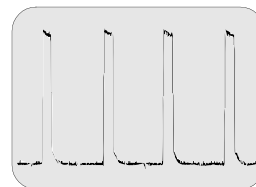

②④ A-Bboard
A26 Pin 10 - 5.04V_{p-p}
NTSC-HD2

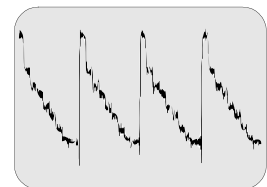

②⑤ A-Bboard
A26 Pin 11 - 1.58V_{p-p}
SUB V/Y

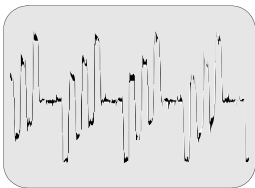

②⑥ A-Bboard
A26 Pin 12 - 1.53V_{p-p}
SUB V/Pb

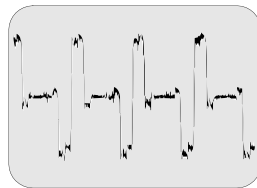

②⑦ A-Bboard
A26 Pin 13 - 1.46V_{p-p}
SUB V/Pr

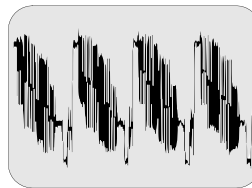

②⑧ A-Bboard
A26 Pin 15 - 2.04V_{p-p}
MAIN V/Y

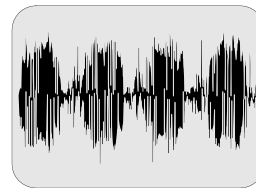

②⑨ A-Bboard
A26 Pin 16 - 0.13V_{p-p}
MAIN C/Pb

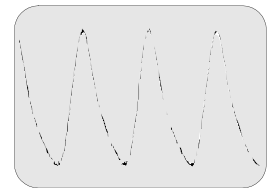

③⑩ A-Bboard
A26 Pin 19 - 2.44V_{p-p}
FSC



31 A-Board
A26 Pin 20 - 1.00V_{p-p}
COMB-C

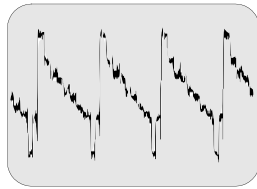

32 A-Board
A26 Pin 21 - 1.28V_{p-p}
COMB-Y

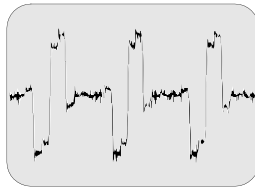

33 A-Board
A26 Pin 28 - 0.91V_{p-p}
Pr

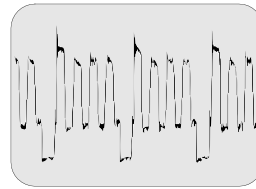

34 A-Board
A26 Pin 29 - 5.20V_{p-p}
BLUE

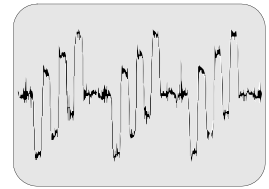

35 A-Board
A26 Pin 30 - 0.74V_{p-p}
Pb

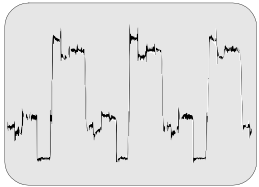

36 A-Board
A26 Pin 31 - 4.92V_{p-p}
GREEN

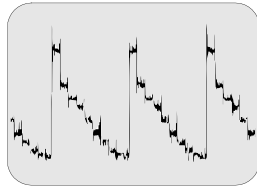

37 A-Board
A26 Pin 32 - 0.82V_{p-p}
Y

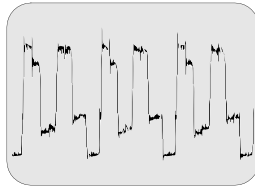

38 A-Board
A26 Pin 33 - 5.28V_{p-p}
RED

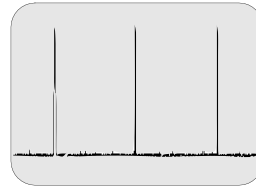

39 A-Board
A26 Pin 34 - 3.32V_{p-p}
VPO1

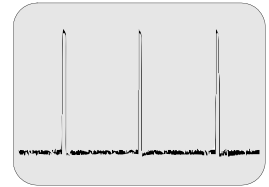

40 A-Board
A26 Pin 35 - 3.60V_{p-p}
CLP

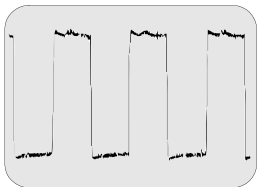

41 Q-Board
Q10 Pin 4 - 4.16V_{p-p}
H-DRIVE

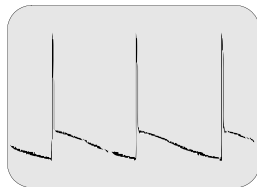

42 Q-Board
Q8 Pin 13 - 84.00V_{p-p}
VH

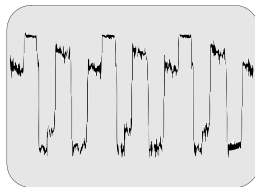

43 L-Board
IC3801 Pin 8 - 172.00V_{p-p}
R-DRIVE

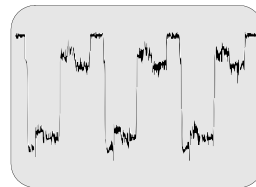

44 L-Board
IC3802 Pin 8 - 176.00V_{p-p}
G-DRIVE

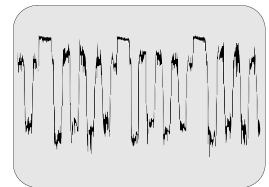

45 L-Board
IC3803 Pin 8 - 166.00V_{p-p}
B-DRIVE

PARTS LIST ABBREVIATIONS GUIDE

RESISTOR			
TYPE		TOLERANCE	
C	Carbon	F	± 1%
F	Fuse	J	± 5%
M	Metal Oxide	K	± 10%
S	Solid	M	± 20%
W	Wire Wound	G	± 2%

RES, C 270-J-1/4

CAPACITOR			
TYPE		TOLERANCE	
C	Ceramic	C	± 0.25pF
E	Electrolytic	D	± 0.5pF
P	Polyester	F	± 1pF
S	Styrol	J	± 5%
T	Tantalum	K	± 10%
		L	± 15%
		M	± 20%
		P	+10% -0%
		Z	+80% -20%

CAP, P .068UF-K-50V

Printed in USA
K00112218PL1110