

Service Manual



Wide Screen TV CT-34WX50 PX1T Chassis

The service technician is required to read and follow the "Safety Precaution" and "Important Safety Notice" in this service manual.

Specifications

Power Source

AC120V, 60Hz

Power Consumption:

Average use: 193.7 W (Maximum Current: 3.7
Stand-by condition: 0.36W

CRT

34-inch, 16:9 aspect ratio (Viewing area)

Applicable signals

Color system : NTSC

Screen size

29.36"(745.9mm)(W)x16.5"(419.5mm)(H)x33.68"(855.7mm)(D)

ANODE Voltage

33.0±1.0kV at zero beam current

Accessories Supplied

Remote control EUR511162
Battery (2xR6 (AA) Size)
Warranty

Speaker Out

5 Speakers
21W(7W+7W+7W) (10% THD)
Impedance 8Ω

Dimension (WxDxH)

34.4"(874mm) x 23.0"(585mm)x25.1"(637mm)

Weight (Mass)

174.0lbs (79kg) Net

Connection terminals

AV INPUT 1-4 VIDEO 1.0Vp-p (75Ω)
(Phono Jack Type)
S-VIDEO Y:1.0Vp-p (75Ω)
(Mini DIN 4-pin)C:0.286 Vp-p (75Ω)
AUDIO L-R 0.5 Vrms
(Phono Jack Type x 2)

AV PROG. OUT VIDEO 1.0Vp-p (75Ω)
(Phono Jack Type)
S-VIDEO Y:1.0 Vp-p (75Ω)
(Mini DIN 4-pin)C:0.286 Vp-p (75Ω)
AUDIO L-R 0.5 Vrms
(Phono Jack Type x 2)

TO AUDIO AMP AUDIO L-R 0.5 Vrms
(Phono Jack Type x 2)

COMPONENT VIDEO
INPUT1-2 Y 1.0 Vp-p (including synchronization)
PB/PR ± 0.35 Vp-p
AUDIO L-R 0.5 Vrms
(Phono Jack Type x 2)

Design and Specifications are subject to change without notice.

Weight and Dimensions shown are approximate.

⚠ WARNING

This service literature is designed for experienced repair technicians only and is not designed for use by the general public. It does not contain warnings or cautions to advise non-technical individuals of potential dangers in attempting to service a product. Products powered by electricity should be serviced or repaired only by experienced professional technicians. Any attempt to service or repair the product or products dealt with in this service literature by anyone else could result in serious injury or death.

Contents

<input type="checkbox"/> Specifications	Cover
<input type="checkbox"/> Safety Precautions	3
<input type="checkbox"/> Self-Check Function	5
<input type="checkbox"/> Chassis Board Layout	7
<input type="checkbox"/> Location of Lead Wiring	8
<input type="checkbox"/> Service Hints	9
<input type="checkbox"/> Entry into Service Adjustment Mode	12
<input type="checkbox"/> Concurrent Mode Function	14
<input type="checkbox"/> Adjustment Method	18
<input type="checkbox"/> Conductor Views	33
<input type="checkbox"/> P-Board	33
<input type="checkbox"/> A-Board	34
<input type="checkbox"/> D-Board	38
<input type="checkbox"/> L-Board	39
<input type="checkbox"/> G-Board	40
<input type="checkbox"/> K-Board	40
<input type="checkbox"/> Schematic Diagrams	41
<input type="checkbox"/> Schematic Diagram Notice	41
<input type="checkbox"/> Remote control Transmitter	41
<input type="checkbox"/> A-Board	42
<input type="checkbox"/> D-Board	46
<input type="checkbox"/> P-Board	48
<input type="checkbox"/> L-Board	49
<input type="checkbox"/> G-Board	50
<input type="checkbox"/> K-Board	50
<input type="checkbox"/> Parts Location	51
<input type="checkbox"/> Mechanical Replacement Parts List	52
<input type="checkbox"/> Replacement Parts List	53

Safety Precautions

General Guidelines

1. It is advisable to insert an isolation transformer in the AC power line before servicing a hot chassis.
2. When servicing, observe the original lead dress, especially the lead dress in the high voltage circuits. If a short circuit is found, replace all parts which have been overheated or damaged by the short circuit.
3. After servicing, see to it that all the protective devices such as insulation barriers, insulation papers, shields, and isolation R-C combinations, are properly installed.
4. Before switching the power on, measure the resistance between B+ line and cold side chassis ground. Connect the “-” side of an ohmmeter to the B+ line, and the “+” side to chassis ground. Each line must have more resistance value than the specified one as follows:

B+ line	Minimum Resistance
220V(TPD7)	10k Ω
144V(TPD17)	10k Ω
23V(TPD25,33)	3k Ω
15V(TPD20)	5k Ω
12V(TPD23)	50k Ω

5. When the set is not used for a long period of time, unplug the AC power cord plug from the AC line outlet.
6. High voltage points, as high as 33 ± 1.0 kV, are present when the set is in operation. Operating the set without the rear cover involves in a dangerous electrical shock from the set power supply. Servicing must not be attempted by anyone who is not thoroughly familiar with the necessary precautions when working on high voltage equipment. Always discharge the anode of the picture tube to chassis ground before handling the picture tube.
7. After servicing, make the following leakage current checks to prevent the customer from dangerous electrical shock.

Leakage Current Cold Check

1. Unplug the AC power cord and short between the two prongs of the AC plug with a jumper wire.
2. Set the power switch of this set to ON position.
3. Measure the resistance value with an ohmmeter between the shorted AC plug and each exposed metallic part of the set cabinet such as screwheads, connectors, and control shafts. When the exposed metallic part has a return path to the chassis, the reading should be more than 1 M Ω .
When the exposed metal part does not have a return path to the chassis, the reading must be infinity.

Leakage Current Hot Check (See Fig.1)

1. Plug the AC power cord directly into the AC line outlet. Do not use an isolation transformer for this check.

2. Connect a 1.5k Ω , 10W resistor, in parallel with a 0.15 μ F capacitor between each exposed metallic part of the set and an earth ground such as a water pipe.
3. Use a high impedance AC voltage meter to measure the voltage across the resistor.
4. Measure the voltage at each exposed metallic part.
5. Reverse the AC plug inserting direction at the AC line outlet and repeat each of the above measurements.
6. The voltage at any point must be less than 0.75Vrms.
7. A leakage current tester (Symptom Model 229 or the equivalent) may be used to make the hot checks. In this case, the current must be less than 500 μ A.
8. If the reading is more than the above value, the set must be repaired and rechecked before it is returned to the customer because of a possibility of an electrical shock.

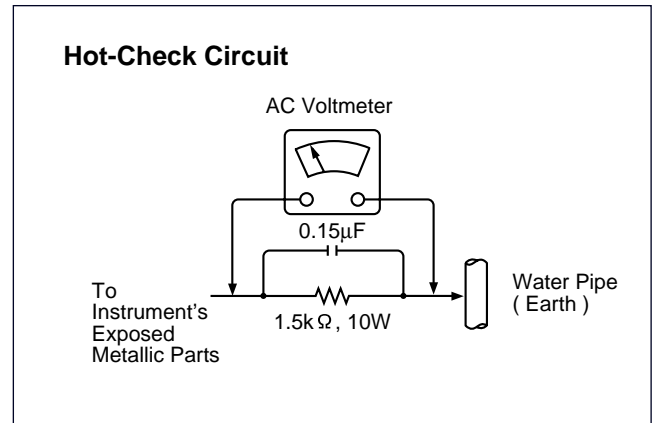

Fig. 1

X-Radiation

Warning:

1. The potential sources of X-Radiation in the monitor set are the high voltage section and picture tube.
2. When using a picture tube test jig for service, make sure that jig is capable of handling 32.5kV without causing X-Radiation.
3. For continued X-radiation protection, in case that at least one of the components listed below is replaced, follow the adjustment procedure of the high voltage circuit. Precise adjustment is necessary for R720 to protect X-Radiation. Refer to "High Voltage and X-Radiation Protective Circuit Adjustment section".

T551, IC457, IC5508, D512, R520, R521, R522, R809, R810, R5568, C481, C528, RL001

HOLD DOWN OR SAFETY CIRCUIT INFORMATION

To monitor the high voltage, the positive DC voltage from the cathode D512 is applied through R788 and other resistors to pin 3 of IC475, which is the input terminal of the X-ray Protection Circuit. The voltage at pin 2 of IC457 is adjusted by R720 at 5.83 +0.01, -0.02 voltage. Under normal conditions this voltage is insufficient to activate the X-ray Protection Circuit.

If the voltage at pin 3 of IC457 increases over the voltage at pin 2 of IC457 and causes the X-ray Protection to activate. Then it causes the shut down works.

In the process described above, the voltage at pin 3 of IC457 is compared with the voltage at pin 2 of IC457. if excessive beam current is drawn, the voltage at pin 3 of IC457 increases. When the voltage at pin 3 of IC457 over the voltage at pin 2 of IC457, the voltage at pin 1 of IC457 becomes "high" and feeds into Base of Q401, and the voltage at Corrector of Q401 becomes "high" and feeds into pin 38 of micro-controller IC5508 through R5618. The micro-controller then turns off Q802, causes the AC power relay RL001 to unlatch and turns off the receiver.

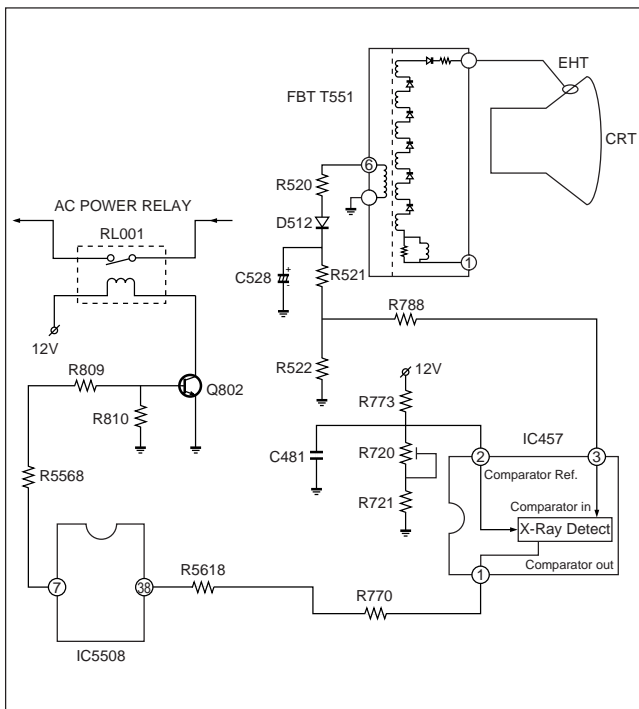

Service Instruction: Procedure to apply silicone to the seal control R720

Purpose

To prevent any adjustment on the sealed control after final adjustment is done at factory. If the sealant are removed for any reason, the control is damaged at same time.

Material

1. Silicone-Type T8C1710201H, manufactured by Shin-Etsu Chemical Co., Ltd. (Japan)
2. Hard ABS tube-Type TMMX004

Tools

No tool is required.

Procedures

1. Place the hard ABS tube on the designated sealed control, as shown in Figure a.

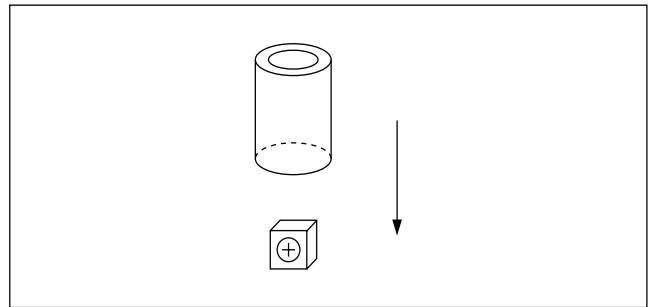

Figure a.

2. When the tube is gently pressed all the way down and adhere to the P.C.B., apply the silicon into the hard ABS tube and form hemisphere like object on the top of tube, as shown in Figure b.

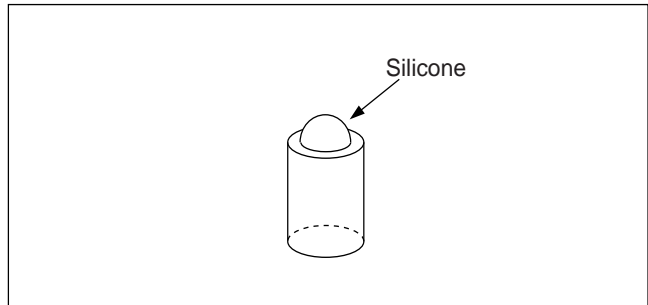
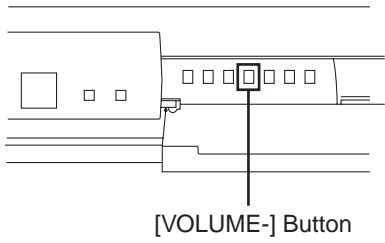

Figure b.

Self-check Function

When symptoms like "the power fails sometimes" or "sometimes there is no picture and/or sound" can not be confirmed at the time of servicing, the self-check function can be used to confirm the occurrence and to find the defective circuit. In case of "power failure", flashing of the "VIDEO IN" indication (red) at the front of the unit can be used to narrow down the +B line.

Self-check of the microcomputer control system (bus line)

Indication method	Screen display						
 <p>[VOLUME-] Button</p>	<div style="border: 1px solid black; padding: 5px;"> <p>hyperOne</p> <table style="width: 100%; border-collapse: collapse;"> <tr> <td style="width: 33%; vertical-align: top;"> Primary IIC DG IC1310 OK H94 IC4504 OK H36 IC4506 OK H45 IC4513 OK H32 IC4514 OK H31 </td> <td style="width: 33%; vertical-align: top;"> H IC3007 OK H33 IC3012 OK H39 IC3013 OK H30 </td> <td style="width: 33%; vertical-align: top;"> A IC5001 OK H90 IC5002 OK H14 IC5003 OK H93 TNR001 OK H10 TNR003 OK H13 </td> </tr> <tr> <td style="vertical-align: top;"> Secondary IIC AG IC2503 OK H34 IC2504 OK H37 IC2505 OK H38 </td> <td style="vertical-align: top;"> A IC2401 OK H21 Q IC452 OK H51 </td> <td></td> </tr> </table> </div> <p style="text-align: right; font-size: small;"> Check result of IC "OK" → Normal "NG" → Abnormal (Check IC or its nearby components) </p>	Primary IIC DG IC1310 OK H94 IC4504 OK H36 IC4506 OK H45 IC4513 OK H32 IC4514 OK H31	H IC3007 OK H33 IC3012 OK H39 IC3013 OK H30	A IC5001 OK H90 IC5002 OK H14 IC5003 OK H93 TNR001 OK H10 TNR003 OK H13	Secondary IIC AG IC2503 OK H34 IC2504 OK H37 IC2505 OK H38	A IC2401 OK H21 Q IC452 OK H51	
Primary IIC DG IC1310 OK H94 IC4504 OK H36 IC4506 OK H45 IC4513 OK H32 IC4514 OK H31	H IC3007 OK H33 IC3012 OK H39 IC3013 OK H30	A IC5001 OK H90 IC5002 OK H14 IC5003 OK H93 TNR001 OK H10 TNR003 OK H13					
Secondary IIC AG IC2503 OK H34 IC2504 OK H37 IC2505 OK H38	A IC2401 OK H21 Q IC452 OK H51						
<p><Indication method> Press the SLEEP button on the other model TV remote control simultaneously with the "VOLUME -" button on the unit. (The display will be switched to the screen of VIDEO 1 and the screen shown on the right will be displayed.)</p>	<p><Return to the normal screen> Return to the normal screen will be made by POWER or any other remote control operation.</p>						
<p>Note: This model's remote controller don't have sleep Button.</p>							

Display Contents

Indication No.	Symptom, status	Treatment method	Applicable Board, applicable Module
H10	No receive for Main picture.	Exchange TNR001.	A-Board
H13	No receive for Sub picture.	Exchange TNR003.	
H14	BEE and LED does not work.	Exchange IC5002.	
H21	No sound.	Exchange IC2401.	
H90	Picture and Sound can not be adjusted.	Exchange IC5001.	
H93	No sound.	Exchange IC5003.	
H30	TV/AV switching is not possible.	Module exchange	H-Module
H33	No video from component (color difference) input.		
H39			
H31	Vector Detector does not operate.	Module exchange	DG-Module
H32	Sub picture is No color (W/B).		
H36	Main picture is No color (W/B).		
H45	The split screen function does not operation.		
H94	Picture is not stationary.		
H34	Abnormal sparsness.		
H37	VM does not work.		
H38	No video, defective OSD.		
H51	Horizontal and vertical synchronization not stationary.	Module exchange	Q-Module

Self check for the power supply

Flashing timing table

When an abnormality has occurred for a power supply line, the protection circuit (power supply protector/detection of abnormal high voltage) operate and cuts the power supply. At this time, the defective line can be identified by the number of flashes (red) of the "Power supply/function standby/video reception" indication at the front of the unit by means of the fault line which has operated the protection circuit.

Flashing	Flashing timing	Contents
Once		High voltage protect
Twice		+25V, +144V overcurrent detection, vertical drive +15V voltage drop
Three times		+5 V voltage drop
Four times		DD module main voltage drop
Five times		DD module sub voltage rise
Six times		Voltage drop (+3.3V/9V/+12V)
Seven times		+25V, +144 V overcurrent detection

Chassis Board Layout

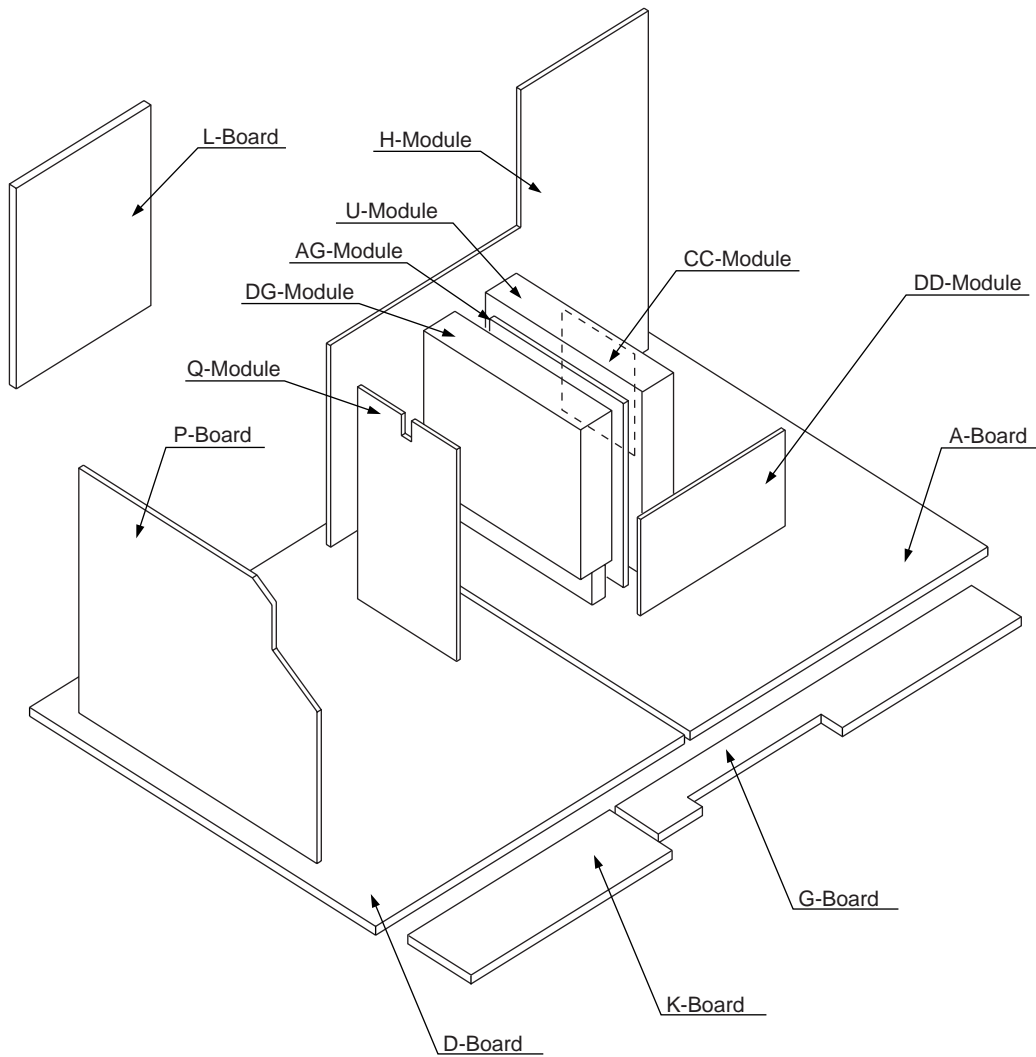

Serviceable Boards

Board Number	Board Designation
TNPA1531	G-Board, Front terminal
TNPA1532	K-Board, LED
TNPA1536AB	L-Board, CRT Drive
TNPA1675	P-Board, AC Power
TNPH0306AF	D-Board, Power Deflection
TNPH0340	A-Board, Main

Non-Serviceable Boards

(See Note)

Board Number	Board Designation
TNPA1520AC	DD-Module, DC DC
TNPA1523AB	Q-Module, V-Deflection
TNPA1524	AG-Module, Analog Core
TNPA1525AD	U-Module, MPU
TNPA1526	DC-Module, Digital Core
TNPA1676	CC-Module, C.C./V chip
TNPA1710	H-Module, AV switching

Note: When a non-serviceable board is determined to be defective, please replace the board and return the defective board to the factory.

Location of Lead Wiring

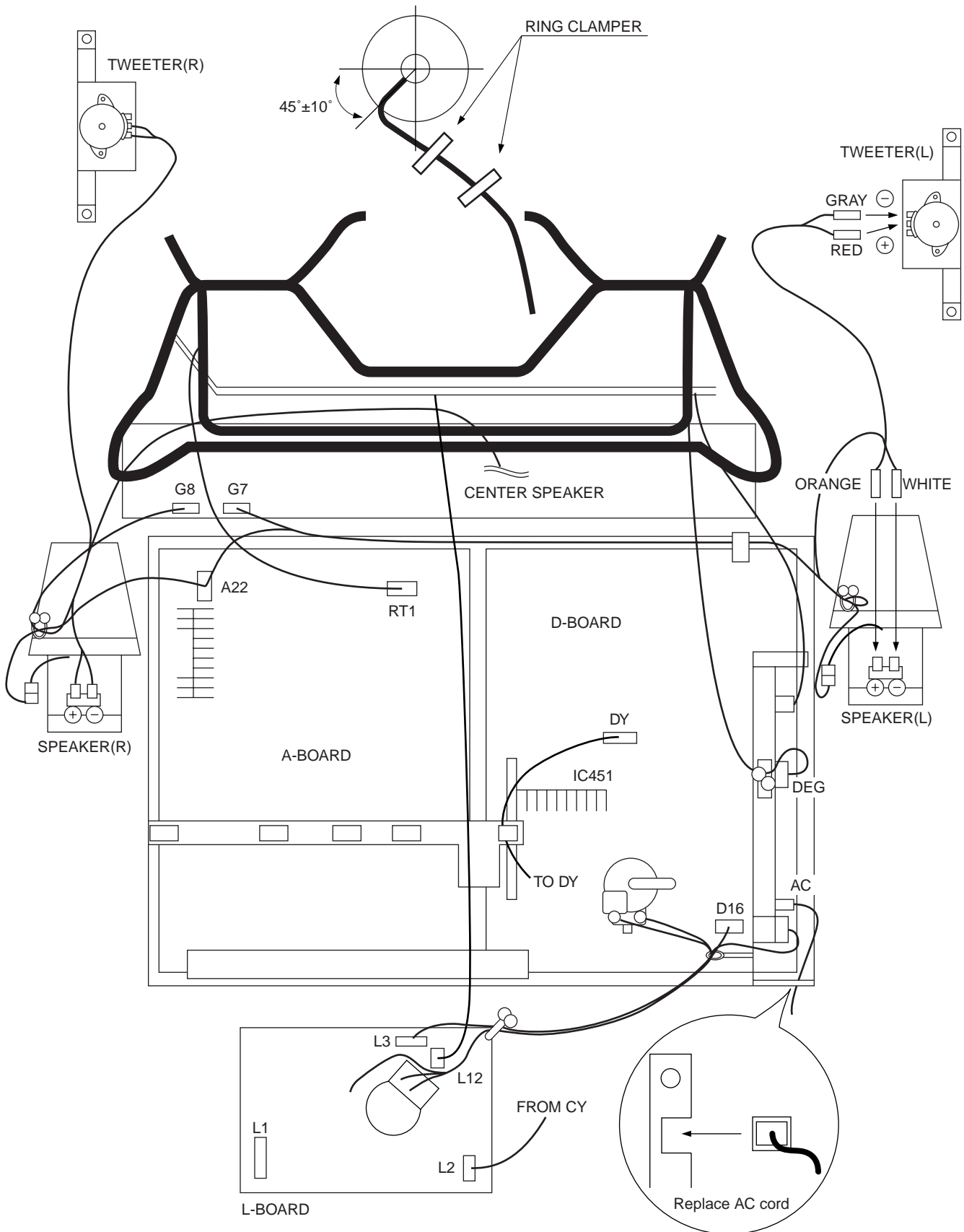

Service Hints

Before servicing

(1) Remove the screws fixing the rear cover (11 pcs.: Refer to Fig. 1).

Fig.1 Positions of the screws fixing the rear cover

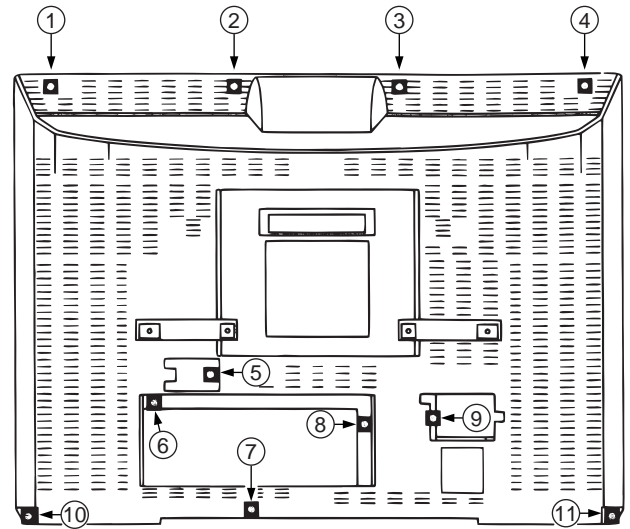

(2) Remove the rear cover by raising the chassis a little ① and pulling to the rear ②. (Refer to Fig. 2.)

* At this time, disconnect the coupler P11, the ring clammer, etc. as required to facilitate the pulling out of the chassis.

Fig.2 How to tilt the chassis

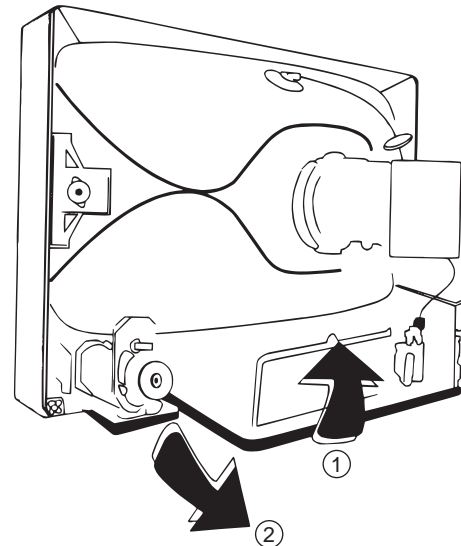

* After completion of servicing, any disconnected couplers and clammers must be restored to their original condition.

Fig.3 Inspection of the A-Board and D-Board

Insert a cloth or similar so that the Board will not have contact.

In regard to inspection of A-Board and D-Board

• The A-Board and D-Board can be inspected from the pattern side when the chassis is pulled out and tilted up. (Refer to Fig. 3.)

* At this time, disconnect the coupler P11, the clamp, etc. as required to facilitate tilting of the chassis.

* When tilting the chassis, pay sufficient attention to the L-Board at the neck of the picture tube

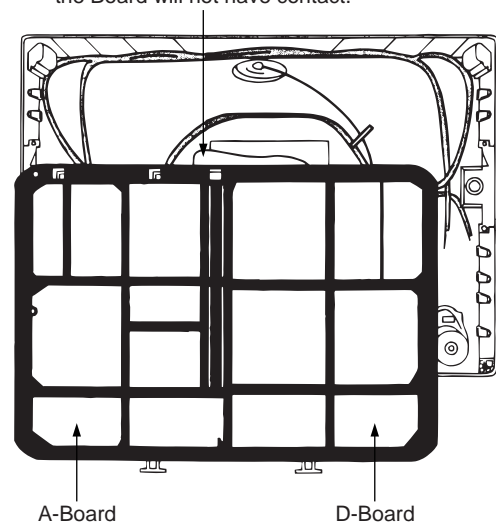

Inspection of the P-Board

- As the P-Board can not be inspected from the pattern side, refer to the pattern side/parts side of the circuit diagram (Page 66, 67), and perform the inspection by bringing the tester into contact with the jumper wires and parts.

Parts exchange for the P-Board

- When parts are to be exchanged, first remove the screws (3 screws: ① to ③ Refer to Fig. 4) fixing the print holder.
- Next, remove the screws (3 screws: ④ to ⑥ :Refer to Fig.4)
- Remove the P-Board from the D-Board (3 connectors: P1 to P3: Refer to Fig. 4), and then exchange the parts.

- * Pay attention to the earthing of HOT and COLD parts and perform inspection.

Service position for P-board

Note: Extension cable kit (2 pieces of 8 pin cables and 1 pieces of 3 pin cable) is supplied as service fixtures and tools.
(Part No, TZSC07022)

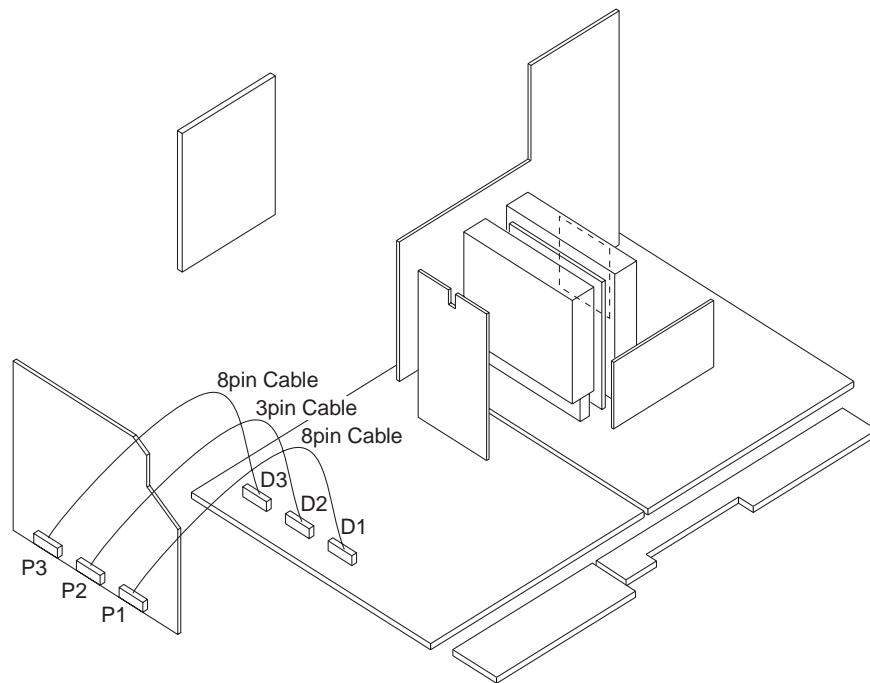

Exchange method for DD-Module

Remove the DD-Module from A-Board (4 connectors: DD10 to DD13), and then exchange the DD-Module.

Exchange method for H-Module

- Remove the rear panel fixing screw (6 screws: ① to ⑥) and the fixing tabs (2 place). (Refer to Fig. 5)
- Tilt the H-Module to the front and pull it out, and then exchange the H-Module.

Fig.4 Inspection of the P-Board

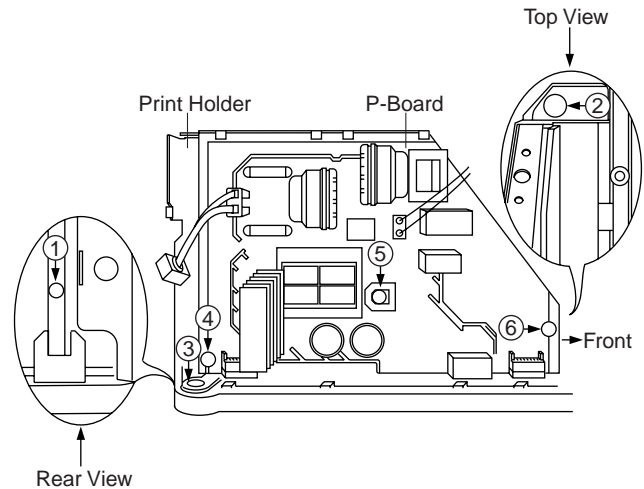
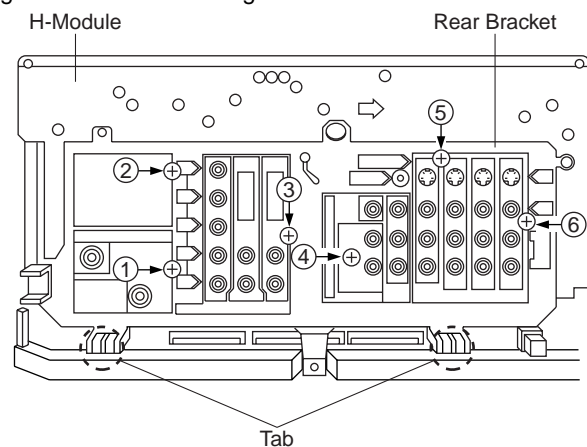

Fig.5 H-Module exchange



Exchange method for CC-Module, U-Module, AG-Module, DG-Module and Q-Module

*Remove the H-Module in advance. (Refer to the preceding item)

Fig. 6 Exchange of each module-1
(View from above)

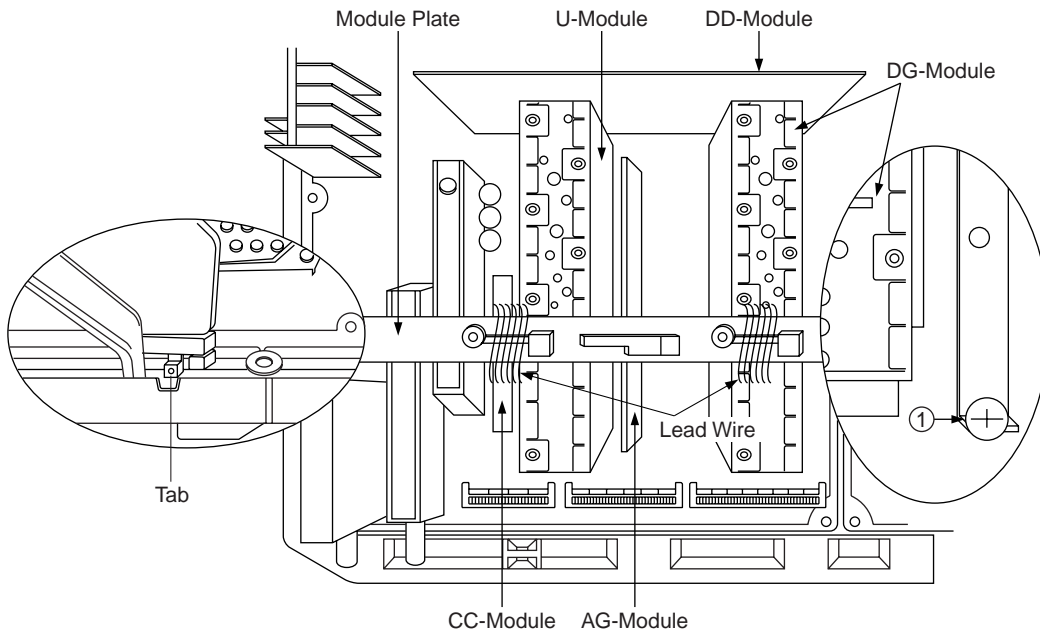
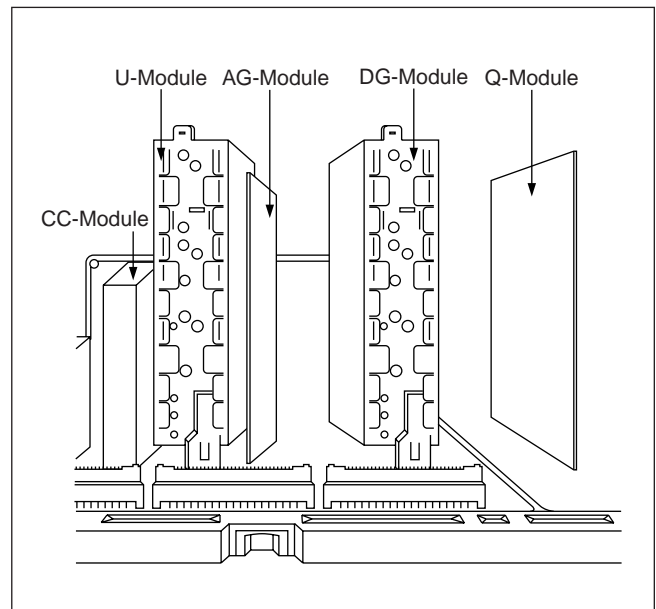

Fig. 7 Exchange of each module-2
(view from the rear)



- (1) Remove the screw (1 screw: ①)
- (2) Remove the lead wire.
- (3) Remove the tab.
- (4) Remove the module plate.
- (5) Pull out each module.
- (6) Exchange module.

Entry into service adjustment mode

Hold the "VOL -" button inside the door of the operation section of this unit pressed and press the "RECALL" button on the remote control three times in a row (within 2 sec.). (Refer to Fig. 1.)

Fig.1 Entry into service adjustment mode

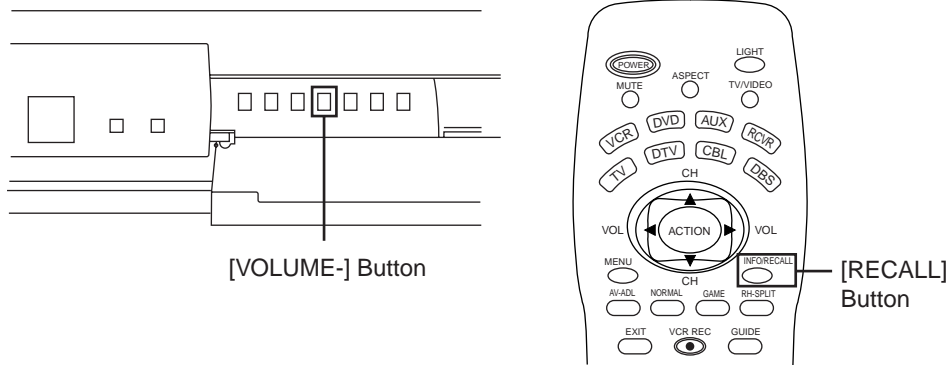
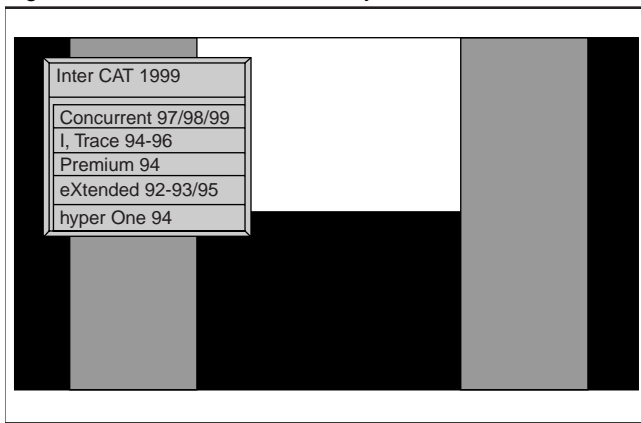

Fig.2 Initial screen for service adjustment mode



- The service adjustment mode has four modes, and only the "Concurrent mode" can be opened. (Refer to Fig. 2.)

(1) Concurrent mode> Select this mode for performing the various adjustments.

Cancellation

Switch off the power or press POWER on the remote control.

At the time of service adjustment

As the values entered in service adjustment mode differ according to the set, perform adjustment operation in service adjustment mode after the values for each item have been prepared.

1. Concurrent Mode

Fig.3 Remote control

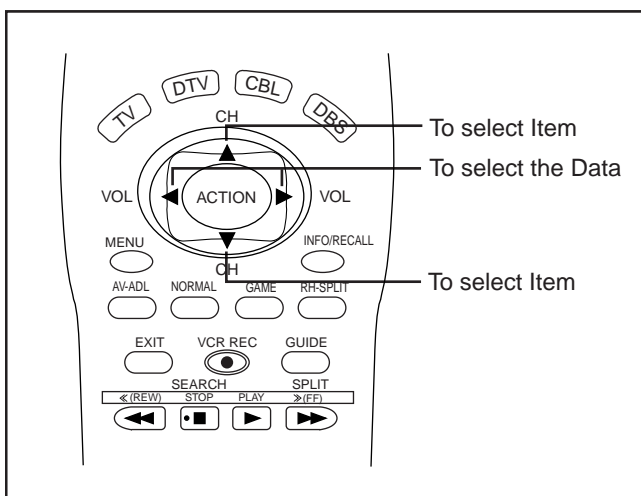

Adjustment method... Use the remote control (refer to Fig. 3)

- Select "Concurrent mode" with the cursor keys [▲] and [▼] of the remote control, and press the "ACTION" key to display the adjustment screen.
 - Button: Selection of main items in forward direction
 - Button: Selection of main items in reverse direction
 - Button: Selection of sub-items in forward direction
 - Button: Selection of sub-items in reverse direction
 - Button: One horizontal line at the time of hybrid gamma adjustment
 - Button: Single-color screen at the time of hybrid gamma adjustment Only R, G, B, Cut-off
 - Button: Built-in cross-hatch pattern
 - Button: Built-in cross-hatch pattern
 - Button: Built-in cross-hatch pattern
- "ACTION" Button: switch main items and sub-items

* (volume +, -) buttons: For adjustment

* Press the NORMAL button for 3 seconds

1.Copy function: (Only hybrid gamma, G cut-off) -> Refer to page 31.

2.Offset function: Only distortion correction -> Refer to page 33.

How to Read the Serve Adjustment Mode

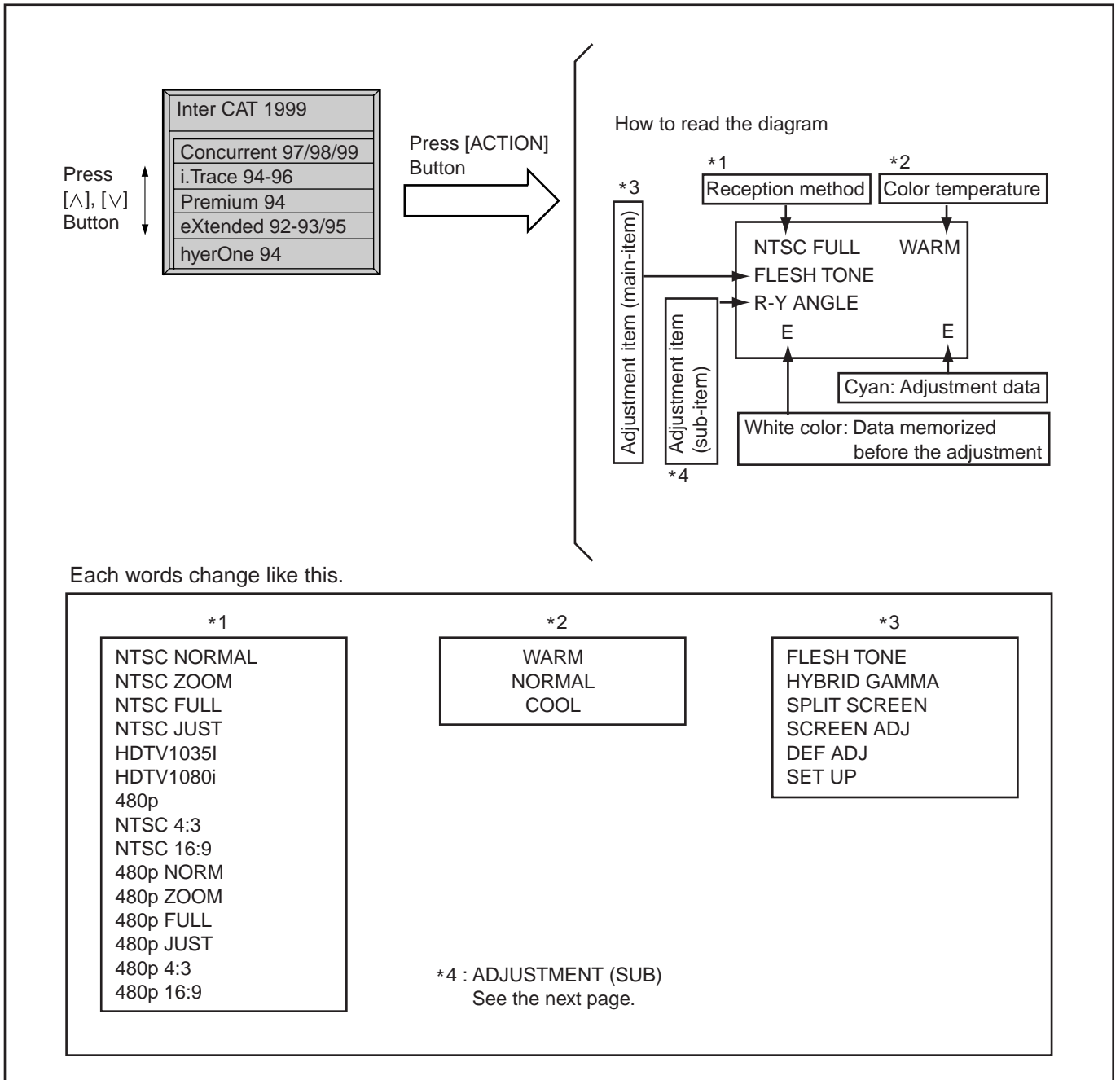

Enter to each functions

- (1) Concurrent---[ACTION]
- (2) i.Trace---[ACTION]
- (3) Premium---[MUTE]-3sec.
- (4) eXtended---None
- (5) hyperOne---None

Concurrent Mode Function

Outline: MPU controls the functions switching for each ICs through IIC bus in this chassis. The following setting and adjustment can be adjusted by remote control in Concurrent Mode.

1. Selection of IIC Mode

Press and hold Volume down [-] key on the front panel of the unit and press RECALL[] Button on the remote control 3 times quickly within 2 seconds.

2. List of the main items of Concurrent mode: The Concurrent mode has six main items, and button [1] of the remote control can be used to go through the main items in forward direction, while button [2] can be used to go through the main items in reverse direction.

How to read the diagram

NORMAL MODE

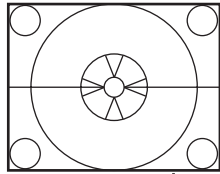

Exit: Turn the power off

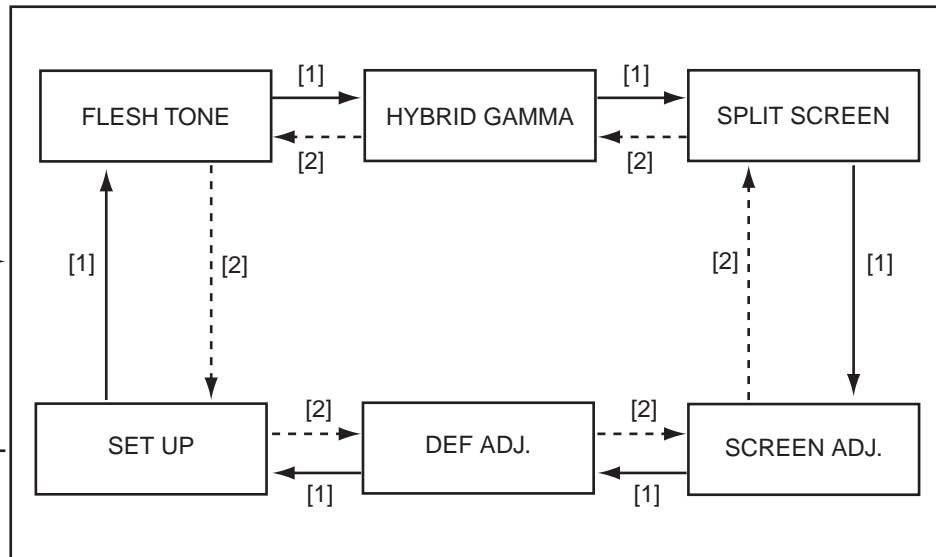

1. FLESH TONE

To change the screen (item) in Concurrent mode, press "3" or "4" of 10 key button. Then Date and Level changes by pressing "Volume +" or "Volume -" button.

No.	Display	Average Data
1	R-Y ANGLE	E
2	B-Y AXIS GAIN	1B
3	SUB TINT	3D
4	SUB COLOR	4B

Note: This adjustment is NTSC FULL mode and HDTV1080i mode only. (Refer to page 17)

2.HYBRID GAMMA

To change the screen (item) in Concurrent mode, press “3” or “4” of 10 key button. Then Data can be changed by pressing “Volume +” or “Volume +” button.

No.	Display	Average Data
1	REAL CONTRAST	37
2	REAL BRIGHT	AA
3	R DRIVE	B7
4	B DRIVE	CC
5	G DRIVE	AF
6	R CUT OFF	1C8
7	B CUT OFF	1A7
8	G CUT OFF	27F
9	SUB CONTRAST	37
10	SUB BRIGHT	9D

Note: This adjustment is NTSC FULL mode and HDTV1080i mode only. (Refer to page 17)

3.SPLIT SCREEN

To change the screen (item) in Concurrent mode, press “3” or “4”10 key button, Then Data can be changed by pressing “Volume +” or “Volume +” button.

No.	Display	Average Data
1	L RF AGC	9F
2	R RF AGC	A4
3	L COLOR VCO	AC
4	R COLOR VCO	AC
5	R SUB BRIGHT	28

Note: This adjustment is NTSC FULL mode and HDTV1080i mode only. (Refer to page 17)

4.SCREEN ADJUSTMENT

To change the screen (item) in Concurrent mode, press “3” or “4” of 10 key button, Then Data can be changed by pressing “Volume +” or “Volume +” button.

No.	Display	Average Data	No.	Display	Average Data
1	H-POSITION	58	8	OSD POS SPLIT	54
2	H-SIZE	4B	9	R-Y BLK LEVEL	8
3	V-POSITION	6E	10	B-Y BLK LEVEL	8
4	V-SIZE	7A	11	DAF PHASE	8
5	BLANKING START	19	12	MOIRE	0
6	BLANKING END	DB	13	H-PULSE DUTY	AA
7	OSD POS	59			

5.DEFECTION ADJUSTMENT

To change the screen (item) in Concurrent mode, press "3" or "4" of 10 key button, Then Data can be changed by pressing "Volume +" or "Volume +" button.

No.	Display	Average Data
1	H-POSITION	58
2	H-SIZE	4B
3	SIDE-PCC	4
4	H-PARALLEL	6
5	H-LINEARTY	66
6	V-POSITION	6E
7	TRAPEZOID	7B
8	V-LINEARITY	21
9	V-SIZE	7A
10	PCC	26
11	EW-CORNER TOP	12
12	EW-CORNER BOTTOM	16
13	V-S CORRECTION	15

6.SET UP

To change the screen (item) in Concurrent mode, press "3" or "4" of 10 key button, Then Data can be changed by pressing "Volume +" or "Volume +" button.

No.	Display	Average Data
1	X-RAY ADJ.	37
2	CRT AGING	0

Note: This adjustment is NTSC FULL mode only. (Refer to page 17)

Service Adjustment Mode

Exchange parts and required adjustment

As shown in the following table, adjustment will be required when some parts have been exchanged.

		MEMORY (IC5001)	DEF. YOKE	F.B.T.	AG MODULE	DG MODULE	Q MODULE	DD MODULE
FLESH TONE	R-YANGE	△	X	X	△	△	X	X
	R-Y AXIS GAIN	△	X	X	△	△	X	X
	SUB TINT	△	X	X	△	△	X	X
	SUB COLOR	△	X	X	△	△	X	X
HYBRID GAMMA	REAL CONTRAST	X	X	X	○	△	X	X
	REAL BRIGHT	X	X	X	○	△	X	X
	R DRIVE	○	X	△	○	△	X	X
	B DRIVE	○	X	△	○	△	X	X
	G DRIVE	○	X	△	○	△	X	X
	R CUT OFF	○	X	△	○	△	X	X
	B CUT OFF	○	X	△	○	△	X	X
	G CUT OFF	○	X	△	○	△	X	X
SPLIT SCREEN	SUB CONTRAST	○	X	△	○	△	X	X
	SUB BRIGHT	○	X	△	○	△	X	X
	L RF AGC	△	X	X	X	△	X	X
	R RF AGC	△	X	X	X	△	X	X
	L COLOR VCO	X	X	X	X	△	X	X
SCREEN ADJ	R COLOR VCO	X	X	X	X	△	X	X
	R SUB BRIGHT	X	X	X	X	△	X	X
	H-POSITION	X	X	X	X	X	X	X
	H-SIZE	X	X	X	X	X	X	X
	V-POSITION	X	X	X	X	X	X	X
	V-SIZE	X	X	X	X	X	X	X
	BLANKING START	X	X	X	X	X	X	X
	BLANKING END	X	X	X	X	X	X	X
	OSD POS	△	△	△	X	△	△	X
	OSD POS SPLIT	△	△	△	X	△	△	X
	R-Y BLK LEVEL	X	X	X	X	X	X	X
	B-Y BLK LEVEL	X	X	X	X	X	X	X
	DAF PHASE	△	△	△	X	X	△	X
MOIRE	X	X	X	X	X	X	X	
H-PULSE DUTY	X	X	X	X	X	X	X	
DEF ADJ	H-POSITION	○	○	△	X	△	○	X
	H-SIZE	○	○	△	X	△	○	X
	SIDE-PCC	○	○	△	X	△	○	X
	H-PARALLEL	○	○	△	X	△	○	X
	H-LINEARITY	○	○	△	X	△	○	X
	V-POSITION	○	○	△	X	△	○	X
	TRAPEZOID	○	○	△	X	△	○	X
	V-LINEARITY	○	○	△	X	△	○	X
	V-SIZE	○	○	△	X	△	○	X
	PCC	○	○	△	X	△	○	X
	EW-CORNER TOP	○	○	△	X	△	○	X
	EW-CORNER BOTTOM	○	○	△	X	△	○	X
V-S CORRECTION	○	○	△	X	△	○	X	
SET UP	X-RAY ADJ	X	X	X	X	X	X	X
	CRT AGING	X	X	X	X	X	X	X

- * "○" indicates that adjustment always is required.
- * "△" indicates that adjustment is to be performed as required.
- * "x" indicates that adjustment is not required.
- * Refer to pages 18 for "white balance adjustment".
- * Refer to pages 19 to 30 for "adjustment of the deflection system".

Adjustment method

Caution items for each adjustment method

[Switching of the color temperature]... Switching of the color temperature between "WARM", "NORMAL", and "COOL" for each adjustment is not done even when "COLOR TEMP" of "PICTURE ADJ" or color temperature fine adjustment of "Technical" is selected. Accordingly, enter into Concurrent mode, press the "AV ADJ" button of the remote control, and select with the left and right cursor button to switch the color temperature.

[At the time of 1080i adjustment]

* Set to a condition where 1080i can be input. Then enter into Concurrent mode, confirm that the on-screen adjustment item is 1080i, and perform adjustment.

[At the time of "DEF ADJ" adjustment]

... Refer to page 19.

White balance adjustment

Perform this white balance adjustment when the white or the black parts on the screen are out of balance or when the picture tube has been exchanged. Before performing white balance adjustment, est the cut-off voltage must be set, and then perform white balance adjustment.

1. Setting of the cut-off voltage

- (1) Receive an NTSC signal and set the aspect ratio to "FULL".
- (2) Enter into Concurrent mode and confirm that the color temperature is "WARM". (See above for setting of WARM/NORMAL/COOL.)
- (3) Select "HYBRID GAMMA" - "REAL BRIGHT" in Concurrent mode and fix the adjustment value to "AF". The select "HYBRID GAMMA" - "G DRIVE" and fix the "G DRIVE" adjustment value to "AF".

*Setting to the above conditions facilitates the adjustment of the pedestal level (DC 170 \pm 5 V) in step (7).

- (4) Turn the screen volume (S1) of the flyback transformer to the left, and set so that the OSD can just be seen.

- (5) Enter into Concurrent mode and select "HYBRID GAMMA" - "G CUT OFF".

- (6) Connect an oscilloscope to TPL2 (G cut-off) on the L-Board. Then press the button "⑥" on the remote control to obtain a green screen, and use the button "⑤" on the remote control to obtain one horizontal line.

*Use TPL9 on the L-Board for probe earth. (There are also TPL11, L7, L8, etc.)

- (7) When the above preparations have been made, use the Volume "+, -" buttons on the remote control to adjust so that the pedestal level of the voltage waveform becomes DC 170 \pm 5 V (refer to Fig. 1).

- (8) After completion of the adjustment, disconnect the oscilloscope, gradually increase the screen volume (S1) (clockwise turning), and fix it where green just starts to shine.

After fixing, press the button "⑤" on the remote control and cancel one horizontal line.

- (9) To copy the adjusted G cut-off data with the same values to the NTSC color temperatures "NORMAL" and "COOL" and to the 1080i color temperatures "WARM", "NORMAL" and "COOL", enter "HYBRID GAMMA"- "G CUT OFF", and press the "NORMAL" button on the remote control for 3 seconds.

*When copying starts, the on-screen display flashes red, and the flashing stops when copying has been completed.

Fig.1 Cut-off voltage

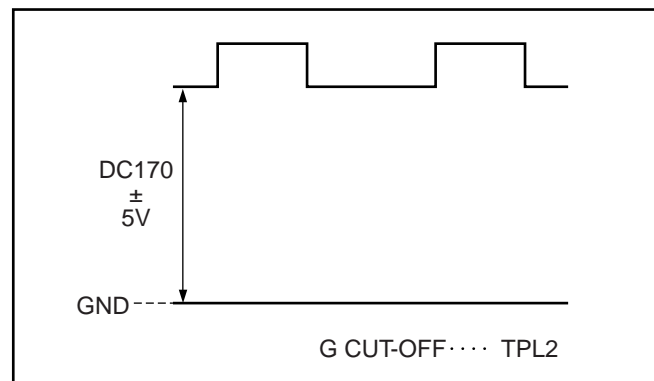

2. White balance adjustment

* At the time of NTSC adjustment... Receive an NTSC signal and set the aspect ratio to "FULL". (-> Set "3D Y/C FILTER " to "ON" only at the time of Receive of an NTSC signal.)

* Perform input paying attention to the reception method: NTSC/1080i.

- (1) Select "HYBRID GAMMA" in Concurrent mode and confirm that the color temperature is "WARM".
- (2) Look at the black parts of the presently input image and check for black floating or black unbalance.
- (3) If there is black floating or black unbalance, select "HYBRID GAMMA" - "R CUT OFF", "B CUT OFF" and adjust with the "Volume-, Volume+" buttons on the remote control. (Low-light adjustment)

*Always have the adjustment values for R cut off and B CUT OFF ready.

- (4) Next, look at the white parts and check for white unbalance.

- (5) If there is white unbalance, select "HYBRID GAMMA" - "R DRIVE", "B DRIVE" and adjust with the "Volume-, " buttons on the remote control. (High-light adjustment)

*Always have the adjustment values for R DRIVE and B DRIVE ready.

- (6) After completion of the adjustment, check the received image, and if there is still unbalance, adjust again according to the steps (3) to (6).

Deflection Adjustment

1. Deflection correction

When DG-Module etc has been exchanged and the H/V-POSITION of the picture, the amplitude, etc. is to be corrected, select "DEF ADJ" in Concurrent mode and adjust the deflection system. "DEF ADJ" has 13 items (sub-items of the Concurrent mode) and adjustment of the image details is possible for each mode/aspect.

The contents of "8 adjustment methods for distortion correction" on pages 20 to 25 are mainly the adjustment contents required for use of the offset function (using the built-in cross-hatch pattern). In addition, the adjustment methods using the monoscope pattern for improvement of the adjustment accuracy also are shown.

2. Offset

(1) What is offset?

- A reference adjustment value (NTSC "FULL" mode and 1080i) is entered, and then the data are offset from the reference value automatically by a single operation of the remote control to facilitate adjustment of this unit.
- Please refer to example 1 to check whether you should use offset or not.
- * Adjustment of the deflection system can be classified into 1. Offset application and 2. Adjustment of the required locations, and the adjustment method should be selected after detailed investigation for each screen mode/reception method.

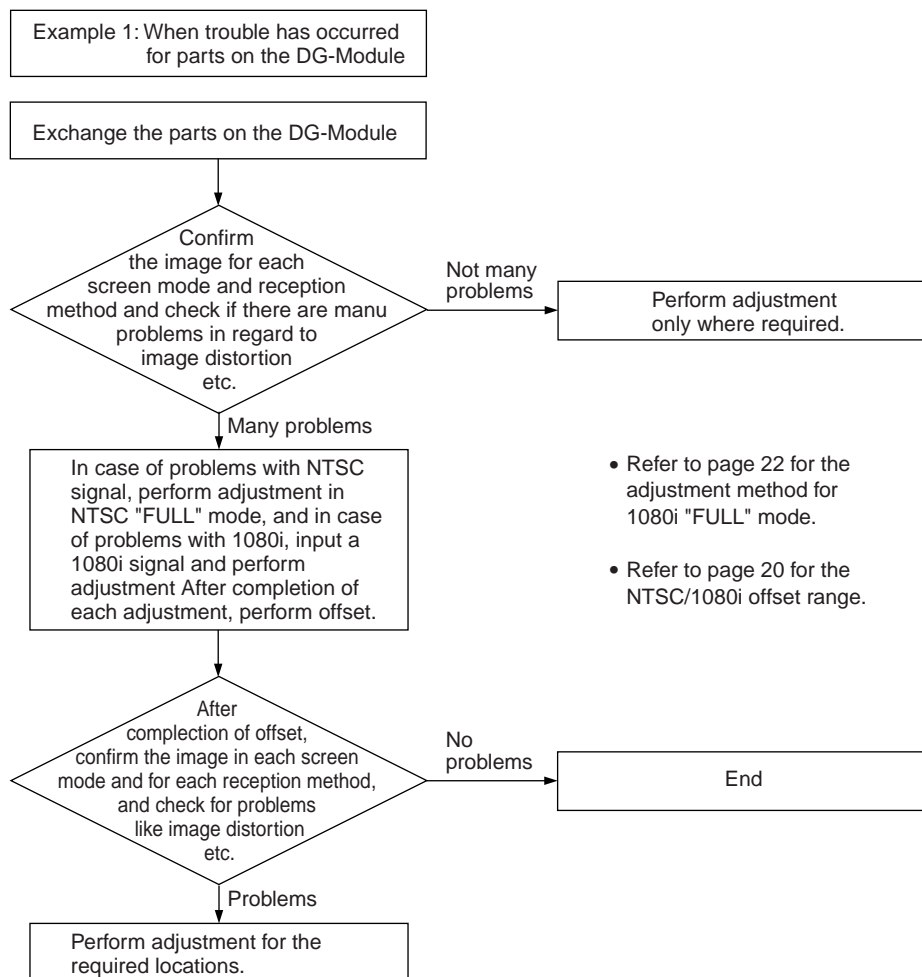

(2) Offset input method

- Offset from NTSC → Receive an NTSC signal and select "DEF ADJ".
- Offset from 1080i → Receive a 1080i signal and select "DEF ADJ".
- After completion of adjustment in NTSC "FULL" mode or 1080i, press the "NORMAL" adjustment value to which adjustment has been made at the time of NTSC FULL mode or 1080i respectively as the initial value, and then the data will be shifted automatically from that value.
- * When offset is started, the on-screen display flashes red, and when this flashing stops, it indicates that offset has been completed.

(3) Caution items for offset data

- Offset data are an adjustment function effective only for "DEF ADJ", and offset is applied independently for NTSC and 1080i.
- Apply offset after adjustment for NTSC "FULL" mode and 1080i has been completed.

Offset data shift table

<1 PICTURE>

Note: Offset data is displayed by 16th digit.

	NTSC FULL	NTSC NORMAL	NTSC ZOOM	NTSC JUST	480p ZOOM	480p FULL	1080i
H-POSITION	●	▲ +9h	▲	▲ -3h	▲ -2Fh	▲ -2Fh	○
H-SIZE	●	▲ -Ah	▲	▲ +1h	▲ -4h	▲ -4h	○
SIDE-PCC	●	▲	▲	▲	▲	▲	○
H-PARALLEL	●	▲	▲	▲	▲	▲	○
H-LINEARITY	●	×	×	×	×	×	×
V-POSITION	●	▲ +2h	▲	▲	▲ -Ah	▲ -Ah	○
TORAPEZOID	●	▲ -1h	▲ -5h	▲ -1h	▲ -5h	▲ -2h	○
V-LINEARITY	●	▲	▲ -1h	▲	▲	▲	○
V-SIZE	●	▲ +1h	▲	▲ +14h	▲ +3Fh	▲	○
PCC	●	▲	▲ -1h	▲ -3h	▲	▲	○
EW-CORNER • TOP	●	▲	▲	▲	▲	▲	○
EW-CORNER • BOTTOM	●	▲ +2h	▲	▲	▲	▲	○
V-S CORRECTION	●	▲	▲	▲ +3h	▲	▲	○

<2 PICTURES>

	NORMAL			FULL			PoutP		
	4 : 3	16 : 9 33.75kHz	16 : 9 31.5kHz	4 : 3	16 : 9 33.75kHz	16 : 9 31.5kHz	4 : 3	16 : 9 33.75kHz	16 : 9 31.5kHz
H-POSITION	▲ +4h	△	▲	▲ +4h	△	▲	▲ +9h	△	▲ +1h
H-SIZE	▲ -4h	△	▲	▲ -4h	△	▲	▲ -4h	△	▲ +2h
SIDE-PCC	▲	△	▲	▲	△	▲	▲	△	▲
H-PARALLEL	▲	△	▲	▲	△	▲	▲	△	▲
H-LINEARITY	×	×	×	×	×	×	×	×	×
V-POSITION	▲ -4h	△	▲ -6h	▲ -7h	△	▲ -9h	▲ -6h	△	▲ -6h
TORAPEZOID	▲ -1h	△	▲ +2h	▲ -4h	△	▲	▲ -1h	△	▲
V-LINEARITY	▲	△	▲ +2h	▲	△	▲ +2h	▲	△	▲ +2h
V-SIZE	▲ +7h	△	▲ -2Dh	▲	△	▲ -1h	▲ +2h	△	▲ +20h
PCC	▲ -14h	△	▲ -11h	▲ -1h	△	▲ +1h	▲	△	▲ -12h
EW-CORNER • TOP	▲ +1h	△	▲	▲	△	▲	▲	△	▲ +1h
EW-CORNER • BOTTOM	▲ +1h	△	▲	▲	△	▲	▲	△	▲ +1h
V-S CORRECTION	▲	△	▲	▲	△	▲	▲	△	▲

- * ● (NTSC "FULL" adjustment value) and ○ (1080i adjustment value) must be adjusted.
- * ▲ shift the NTSC "FULL" adjustment value. (NTSC offset range)
- * △ shift the 1080i adjustment value. (1080i offset range)
- * "x" can not be adjusted.

3. Adjustment in NTSC "FULL" mode

- (1) Receive an NTSC signal and set the aspect ratio to "FULL" mode.
- (2) Enter into service adjustment mode and select "DEF ADJ" in Concurrent mode.
- (3) Press the button "Ⓢ" on the remote control and receive the built-in cross-hatch pattern of this unit.
- (4) First, match the center of the built-in cross-hatch pattern (center adjustment).
Select "V/H-POSITION", perform adjustment on the basis of the specified values, and match the center of the built-in cross-hatch pattern.

*In case of problems with the vertical and/or H-SIZE, select "V/H-SIZE" and adjust.

*Center adjustment (V/H-SIZE) can be speeded up by using the monoscope pattern of the unit generating the signal.

Adjustment methods (specified values)

**"V-POSITION" adjustment method → Refer to page 28.

**"H-POSITION" adjustment method → Refer to page 26.

**"V-SIZE" adjustment method → Refer to page 29.

**"H-SIZE" adjustment method → Refer to page 26.

- (5) Adjust the vertical lines.
When the vertical lines of the built-in cross-hatch pattern are bow-shaped or show parallelogram distortion, select "SIDE-PCC", "H-PARALLEL", and adjust so that the distorted vertical lines become vertical to the horizontal lines.

**"SIDE-PCC" adjustment method → Refer to page 27.

**"H-PARALLEL" adjustment method → Refer to page 27.

- (6) Adjust the horizontal lines.
When the interval between two neighboring horizontal lines of the built-in cross-hatch pattern is not uniform, select "V-LINEARITY", "V-S CORRECTION", and adjust for a good balance of the interval between the horizontal lines.

**"V-LINEARITY" adjustment method → Refer to page 28.

**"V-S CORRECTION" adjustment method → Refer to page 30.

*When "V-LINEARITY", "V-S CORRECTION" adjustment is performed, the horizontal lines of the built-in cross-hatch pattern are adjusted to the top (bottom), so that the position of the screen center changes. Accordingly, the center adjustment must be adjusted again after completion of the adjustment. (Only V-POSITION, amplitude)

- (7) Perform adjustment of the H-LINEARITY.
Refer to page 27, confirm that the adjustment point of the built-in cross-hatch pattern matches the specified value, and adjust if required.

**"H-LINEARITY" adjustment method → Refer to page 27.

- (8) Perform adjustment of the image geometry.
When the geometry of the built-in cross-hatch pattern shows pincushion distortion or distortion at the top or bottom, select "PCC", "EW-CORNER TOP", or "EW-CORNER BOTTOM", and adjust so that the distorted vertical lines become straight lines.

**"PCC" adjustment method → Refer to page 29.

**"EW-CORNER TOP" adjustment method → Refer to page 30.

**"EW-CORNER BOTTOM" adjustment method → Refer to page 30.

- (9) After completion of adjustment, end the service adjustment mode, Receive an NTSC signal in "FULL" aspect ratio, and confirm the image.

4. Adjustment in NTSC "NORMAL" mode

- (1) Receive an NTSC signal and set the aspect ratio to "NORMAL" mode.
- (2) Enter into service adjustment mode and select the Concurrent mode "DEF ADJ".
- (3) For "SIDE-PCC", "H-PARALLEL", "V-POSITION", "TRAPEZOID", "V-LINEARITY", "V-SIZE", "EW-CORNER · TOP", "EW-CORNER · BOTTOM", and "V-S CORRECTION", enter the same adjustment values as for the adjusted NTSC "FULL" mode with the "Volume +, Volume -" buttons on the remote control.

- (4) Receive the built-in cross-hatch pattern of this unit, and if the image geometry shows pincushion distortion or distortion at the top or bottom, select "PCC", "EW-CORNER TOP", or "EW-CORNER BOTTOM", and adjust so that the distorted vertical lines become straight lines.

Adjustment methods (specified values)

**"PCC" adjustment method → Refer to page 29.

**"EW-CORNER TOP" adjustment method → Refer to page 30.

**"EW-CORNER BOTTOM" adjustment method → Refer to page 30.

- (5) Confirm the image blanking width.
- (6) Place a ruler against the surface of the picture tube and measure the measuring points Q and R (refer to the figure on the right).
- (7) If the measuring results show that Q or R deviates from the specified values of the figure on the right, adjust the "H-POSITION" with the "Volume +, Volume -" buttons on the remote control so that the blanking width reaches the specified value.

*If the V-SIZE is not correct, select "V-SIZE" and perform adjustment.

(Refer to page 29 for the "V-SIZE" adjustment method.)

*Do not select "BLANKING START/END" for the effective screen and perform adjustment.

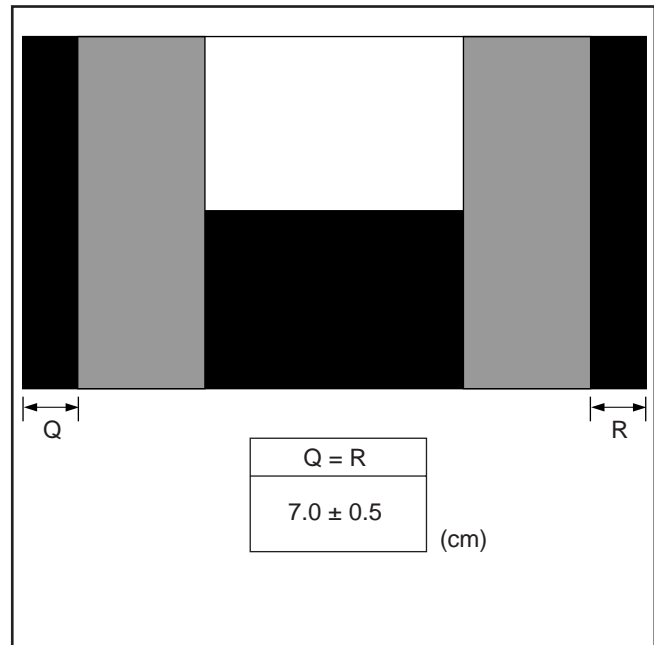

- (8) After completion of the adjustment, Receive an NTSC signal with "NORMAL" mode for the aspect ratio and check the image.

5. Adjustment in NTSC "ZOOM" mode

(1) Receive an NTSC signal and set the aspect ratio to "ZOOM" mode.

(2) Enter into service adjustment mode and select "DEF ADJ" in Concurrent mode.

*When entering into Concurrent mode, the screen position and the amplitude become standard.

(3) Press the button "Ⓢ" of the remote control and receive a built-in cross-hatch pattern of this unit.

(4) For "H-POSITION", "H-SIZE", "SIDE-PCC", "H-PARALLEL", "V-POSITION", "PCC", "EW-CORNER · TOP", "EW-CORNER · BOTTOM", and "V-S CORRECTION", enter the same adjustment values as for the adjusted NTSC "FULL" mode with the "Volume +, Volume -" buttons on the remote control.

(5) Check the center of the built-in cross-hatch pattern (center adjustment).

Select "V/H-POSITION", perform adjustment on the basis of the specified values, and match the center of the built-in cross-hatch pattern.

*In case of problems with the vertical and/or H-SIZE, select "V/H-SIZE" and adjust.

*Center adjustment can be speeded up by using the monoscope pattern of the unit generating the signal.

(6) Adjust the vertical lines.

When the vertical lines of the built-in cross-hatch pattern are bow-shaped or show parallelogram distortion, select "SIDE-PCC", "H-PARALLEL", and adjust so that the distorted vertical lines become vertical to the horizontal lines.

(7) Adjust the horizontal lines.

When the interval between two neighboring horizontal lines of the built-in cross-hatch pattern is not uniform, select "V-LINEARITY", "V-S CORRECTION", and adjust for a good balance of the interval between the horizontal lines.

(8) Check the image geometry.

When the geometry of the built-in cross-hatch pattern shows pincushion distortion or distortion at the top or bottom, select "PCC", "EW-CORNER TOP", or "EW-CORNER BOTTOM", and adjust so that the distorted vertical lines become straight lines.

(9) After completion of adjustment, end the service adjustment mode, Receive an NTSC signal in "ZOOM" aspect ratio, and confirm the image.

Adjustment methods (specified values)

**"V-POSITION" adjustment method → Refer to page 28.

**"H-POSITION" adjustment method → Refer to page 26.

**"V-SIZE" adjustment method → Refer to page 29.

**"SIDE-PCC" adjustment method → Refer to page 27.

**"H-PARALLEL" adjustment method → Refer to page 27.

**"V-LINEARITY" adjustment method → Refer to page 28.

**"V-S CORRECTION" adjustment method → Refer to page 30.

**"PCC" adjustment method → Refer to page 29.

**"EW-CORNER TOP" adjustment method → Refer to page 30.

**"EW-CORNER BOTTOM" adjustment method → Refer to page 30.

6. Adjustment in NTSC "JUST" mode

- (1) Receive an NTSC signal and set the aspect ratio to "JUST" mode.
- (2) Enter into service adjustment mode and select "DEF ADJ" in Concurrent mode.
- (3) For "H-POSITION", "SIDE-PCC", "H-PARALLEL", "V-POSITION", "TRAPEZOID", and "PCC", enter the same adjustment values as for the adjusted NTSC "FULL" mode with the "Volume +, Volume -" buttons on the remote control.
- (4) Press the button "Ⓢ" on the remote control and receive the built-in cross-hatch pattern of this unit.
- (5) Check the center of the built-in cross-hatch pattern (center adjustment).
Select "V/H-POSITION", perform adjustment on the basis of the specified values, and match the center of the built-in cross-hatch pattern.

*In case of problems with the vertical and/or horizontal amplitude, select "V/H-SIZE" and adjust.

*Center adjustment (V/H-SIZE) can be speeded up by using the monoscope pattern of the unit generating the signal.

- (6) Check the image geometry.
When the geometry of the built-in cross-hatch pattern shows pincushion distortion or distortion at the top or bottom, select "PCC", "EW-CORNER TOP", or "EW-CORNER BOTTOM", and adjust so that the distorted vertical lines become straight lines.
- (7) After completion of adjustment, end the service adjustment mode, Receive an NTSC signal in "JUST" mode for the aspect ratio, and confirm the image.

Adjustment methods (specified values)

**"V-POSITION" adjustment method → Refer to page 28.

**"H-POSITION" adjustment method → Refer to page 26.

**"V-SIZE" adjustment method → Refer to page 29.

**"H-SIZE" adjustment method → Refer to page 26.

**"PCC" adjustment method → Refer to page 28.

**"EW-CORNER TOP" adjustment method → Refer to page 30.

**"EW-CORNER BOTTOM" adjustment method → Refer to page 30.

7. 1080i adjustment

(1) Receive a 1080i.

(2) Enter into service adjustment mode and select "DEF ADJ" in Concurrent mode.

(3) Press the button "Ⓢ" on the remote control and receive the built-in 1080i cross-hatch pattern of this unit.

(4) First, match the center of the built-in cross-hatch pattern (center adjustment)

Select "V/H-POSITION", perform adjustment on the basis of the specified values, and match the center of the built-in cross-hatch pattern.

*In case of problems with the vertical and/or H-SIZE, select "V/H-SIZE" and adjust.

(5) Adjust the vertical lines.

When the vertical lines of the built-in cross-hatch pattern are bow-shaped or show parallelogram distortion, select "SIDE-PCC", "H-PARALLEL", and adjust so that the distorted vertical lines become vertical to the horizontal lines.

(6) Adjust the horizontal lines.

When the interval between two neighboring horizontal lines of the built-in cross-hatch pattern is not uniform, select "V-LINEARITY", "V-S CORRECTION", and adjust for a good balance of the interval between the horizontal lines.

*When "V-LINEARITY", "V-S CORRECTION" adjustment is performed, the horizontal lines of the built-in cross-hatch pattern are adjusted to the top (bottom), so that the position of the screen center changes. Accordingly, the center adjustment must be adjusted again after completion of the adjustment. (Only V-POSITION, amplitude)

(7) Perform adjustment of the image geometry.

When the geometry of the built-in cross-hatch pattern shows pincushion distortion or distortion at the top or bottom, select "PCC", "EW-CORNER TOP", or "EW-CORNER BOTTOM", and adjust so that the distorted vertical lines become straight lines.

*Adjust so that the adjustment value for "EW-CORNER TOP" and "EW-CORNER BOTTOM" becomes a value from 5 to 11.

(8) After completion of adjustment, end the service adjustment mode, Receive a 1080i, and confirm the image.

Adjustment methods (specified values)

**"V-POSITION" adjustment method → Refer to page 28.

**"H-POSITION" adjustment method → Refer to page 26.

**"V-SIZE" adjustment method → Refer to page 26.

**"H-SIZE" adjustment method → Refer to page 26.

**"SIDE-PCC" adjustment method → Refer to page 27.

**"H-PARALLEL" adjustment method → Refer to page 27.

**"V-LINEARITY" adjustment method → Refer to page 27.

**"V-S CORRECTION" adjustment method → Refer to page 30.

**"PCC" adjustment method → Refer to page 29.

**"EW-CORNER TOP" adjustment method → Refer to page 30.

**"EW-CORNER BOTTOM" adjustment method → Refer to page 30.

8. Adjustment methods for distortion correction

- "H-POSITION" adjustment

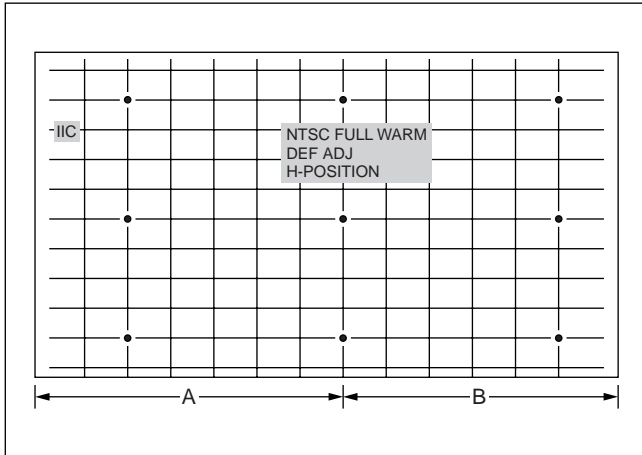

→ Press the "Volume +, Volume -" buttons on the remote control and adjust so that the center of the vertical lines of the built-in cross-hatch pattern becomes stable at the specified value of the following table.

	A	B	A+B
NTSC FULL	396	354	750
1080i	380	378	758

(mm)

- "H-SIZE" adjustment

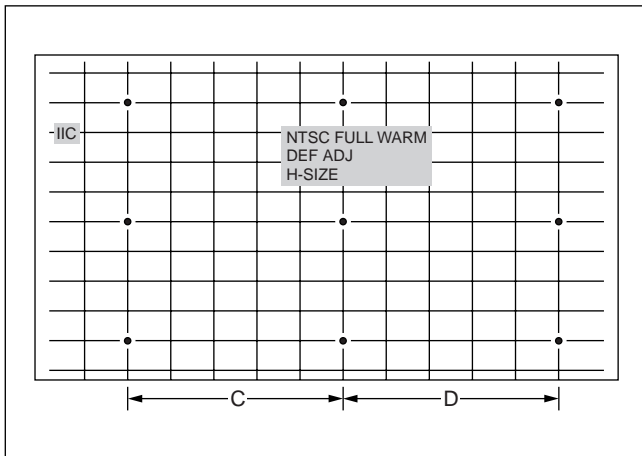

→ Press the "Volume +, Volume -" buttons on the remote control and adjust so that the position 5 lines to the left from the center of the vertical lines of the built-in cross-hatch pattern... (C) and the position 5 lines to the right from the center... (D) becomes stable at the specified value of the following table.

	C	D	C+D
NTSC FULL	284	274	558
1080i	272	262	534

(mm)

- When there is a monoscope pattern

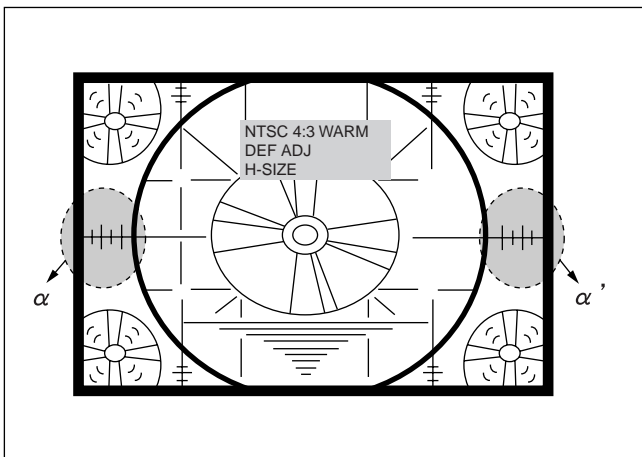

→ Press the "Volume +, Volume -" buttons on the remote control and adjust so that the left (α) and the right (α') end of the scale at the sides of the received monoscope pattern for each aspect ratio becomes stable at the specified value of the following table.

	$\alpha=\alpha'$
NTSC FULL	2.5 ± 0.1
NTSC ZOOM	2.5 ± 0.2
NTSC JUST	2.8 ± 0.1

(Scale)

• "SIDE-PCC" correction

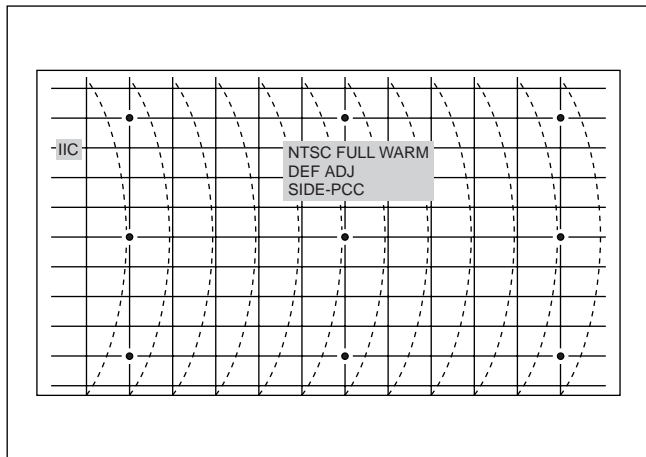

→ When the vertical lines of the built-in cross-hatch pattern show bow-shaped distortion (like the dotted lines in the figure on the left), use the center of the vertical lines as reference, press the "Volume +, Volume - " buttons on the remote control and adjust so that the reference line becomes a straight line.

• "H-PARALLEL" adjustment

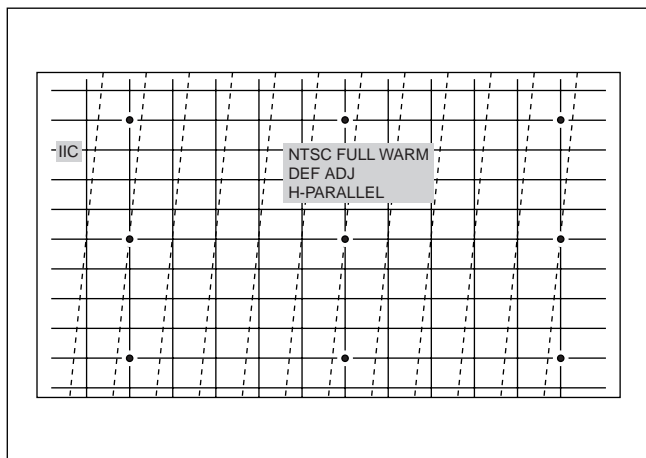

→ When the lines at the left and right edge have a parallelogram component (like the dotted lines in the figure on the left), use the center of the vertical lines as reference, press the "Volume +, Volume - " buttons on the remote control and adjust so that the reference line becomes a vertical line.

• "H-LINEARITY" adjustment

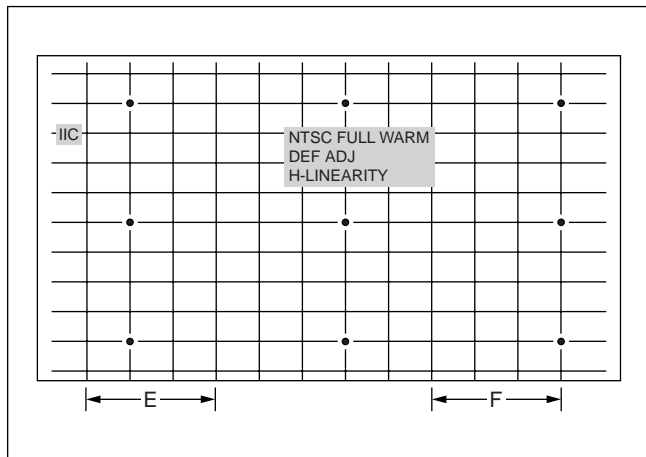

→ Press the "Volume +, Volume - " buttons on the remote control and adjust so that the position 3 lines to the left from the center of the vertical lines of the built-in cross-hatch pattern... (E) and the position 3 lines to the right from the center... (F) becomes stable at the specified value of the following table.

$$F - E = 2 \pm 5 \text{ (mm)}$$

• "V-POSITION" adjustment

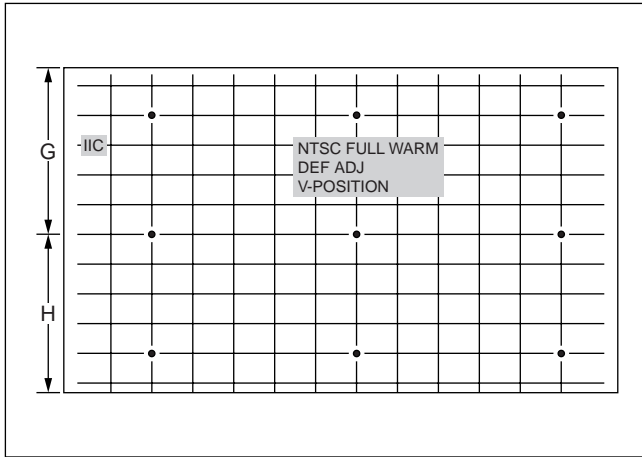

→ Press the "Volume +, Volume -" buttons on the remote control and adjust so that the center of the horizontal lines of the built-in cross-hatch pattern becomes stable at the specified value of the following table.

	G	H	G+H
NTSC FULL	220	202	422
1080i	223	199	422

(mm)

• "TRAPEZOID" adjustment

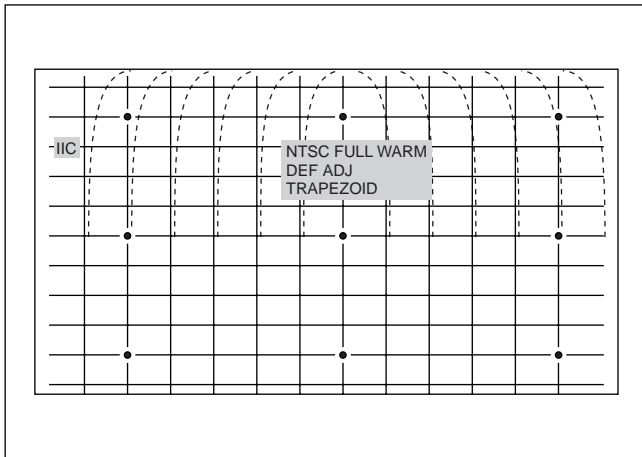

→ When the vertical lines of the built-in cross-hatch pattern show trapezoidal distortion (refer to the dotted lines in the figure on the left), use the vertical lines on the outside as reference, press the "Volume +, Volume -" buttons on the remote control and adjust so that the reference line becomes a vertical line.

• "V-LINEARITY" adjustment

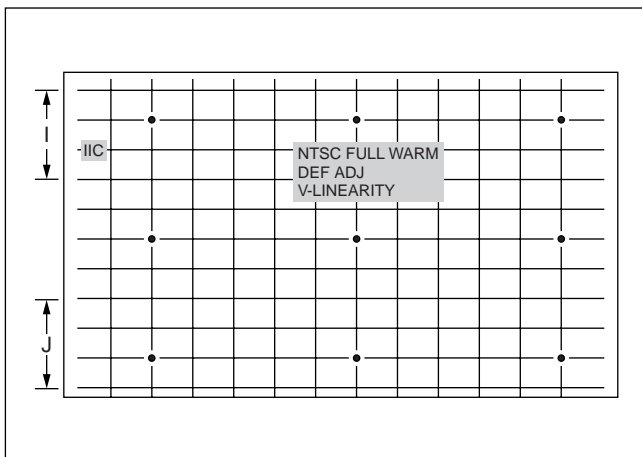

→ Press the "Volume +, Volume -" buttons on the remote control and adjust so that the line interval between adjacent horizontal lines in the upper half and in the lower half of the built-in cross-hatch pattern becomes uniform ($I = J$).

*When the "V-LINEARITY" is adjusted, also adjust the "V-S CORRECTION" at the same time.

*Refer to page 30 for the "V-S CORRECTION" adjustment.

• "V-SIZE" adjustment

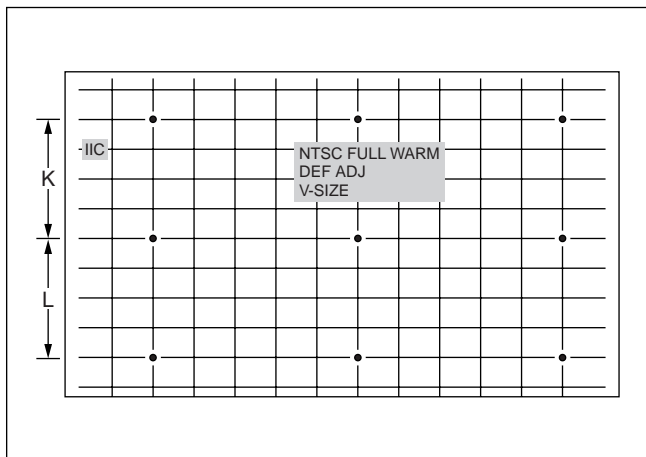

→ Press the "Volume +, Volume - " buttons on the remote control and adjust so that the position 4 lines to the top from the center of the horizontal lines of the built-in cross-hatch pattern ... (K) and the position 4 lines to the bottom from the center... (L) becomes stable at the specified value of the following table.

	K	L	K+L
NTSC FULL	155	153	308
1080i	140	140	280

(mm)

• When there is a monoscope pattern

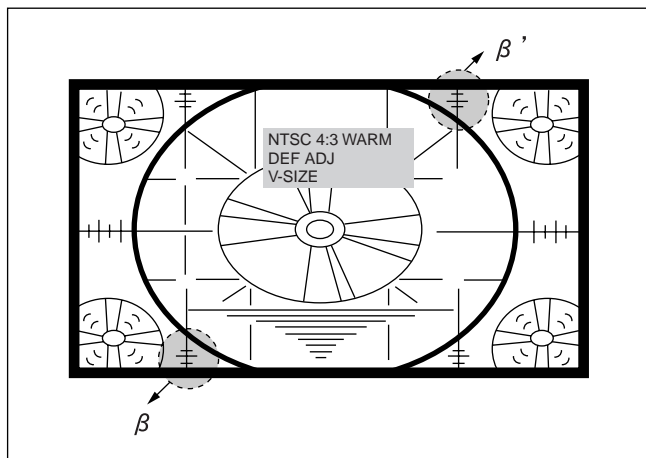

→ Press the "Volume +, Volume - " buttons on the remote control and adjust so that the top (β) and the bottom (β') of the scale of the received monoscope pattern for each aspect ratio becomes stable at the specified value of the following table.

	$\beta = \beta'$
NTSC FULL	2.0±0.2
NTSC NORMAL	
NTSC JUST	1.8±0.1

(Scale)

• "PCC" adjustment

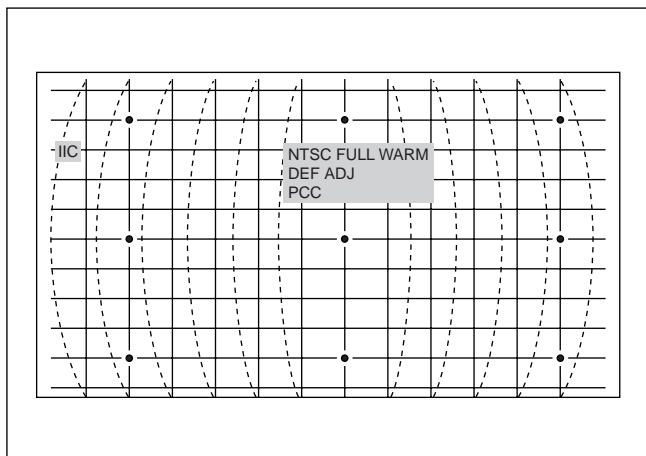

→ When the vertical lines of the built-in cross-hatch pattern show pincushion distortion (refer to the dotted lines in the figure on the left), use the first and the third line on the outside at the left and right as reference lines, press the "Volume +, Volume - " buttons on the remote control and adjust so that the reference lines become vertical lines.

- **"EW-CORNER TOP" adjustment**

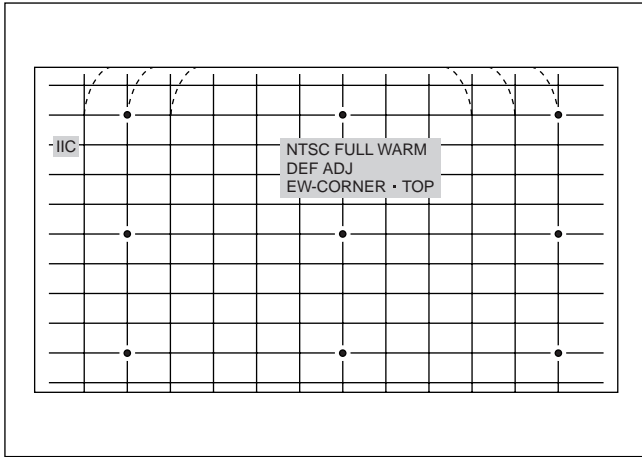

→ When the upper part of the vertical lines at the outer sides of the built-in cross-hatch pattern shows distortion at the top (refer to the dotted lines in the figure on the left), press the "Volume +, Volume - " buttons on the remote control and adjust so that the distorted lines become vertical lines.

- **"EW-CORNER BOTTOM" adjustment**

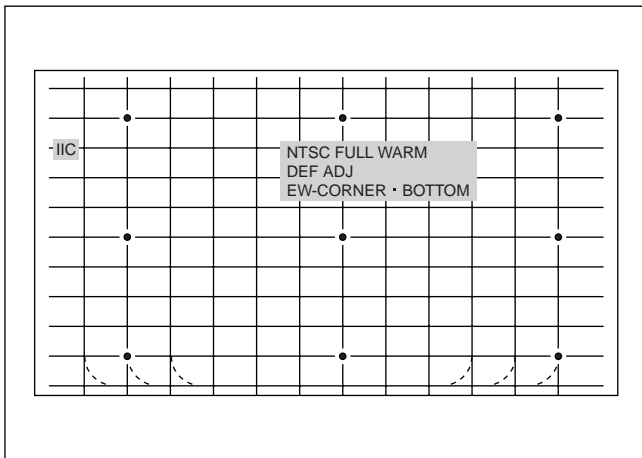

→ When the lower part of the vertical lines at the outer sides of the built-in cross-hatch pattern shows distortion at the bottom (refer to the dotted lines in the figure on the left), press the "Volume +, Volume - " buttons on the remote control and adjust so that the distorted lines become vertical lines.

- **"V-S CORRECTION" adjustment**

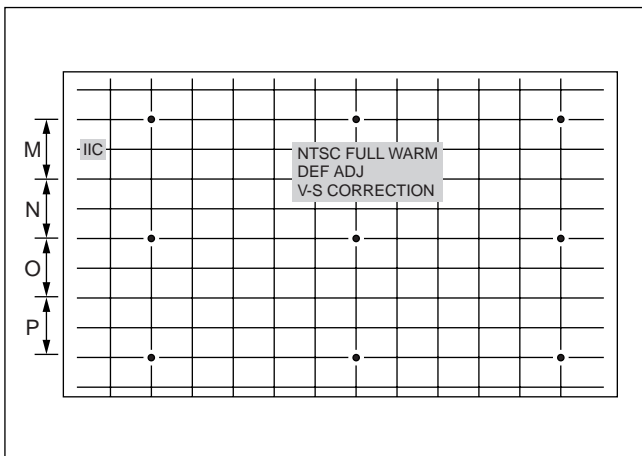

→ Press the "Volume +, Volume - " buttons on the remote control and adjust so that the interval between adjacent lines of the built-in cross-hatch pattern become uniform at the center (N/O: Refer to the figure on the left) and at the top and the bottom (M/P: Refer to the figure on the left).

Focus adjustment

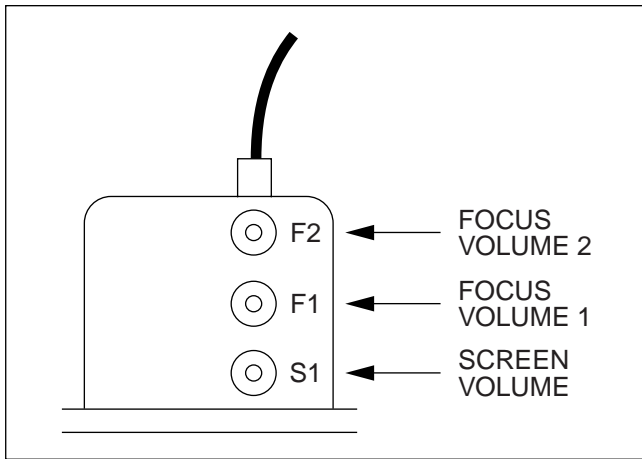
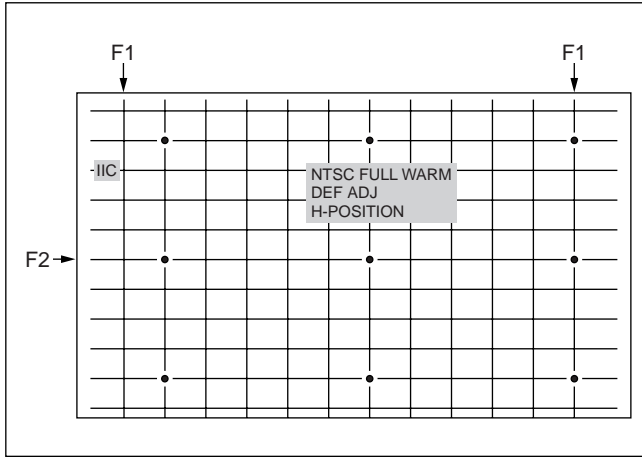

- (1) Receive a NTSC signal.
- (2) Enter into service adjustment mode and select "DEF ADJ" in Concurrent mode.
- (3) Press the button "Ⓢ" on the remote control and receive the built-in cross-hatch pattern of this unit.
- (4) Adjust the F1 control of the flyback transformer so that the focus is balanced for the center line (vertical) of the cross-hatch pattern and the vertical lines two lines from the edge.
- (5) Adjust the F2 control of the flyback transformer so that the center lines (horizontal) of the cross-hatch pattern are balanced well.
- (6) Repeat the adjustments (4) and (5) until an optimum is obtained.
- (7) Receive an NTSC signal in "FULL" mode and confirm the image.

Memo

Conductor Views

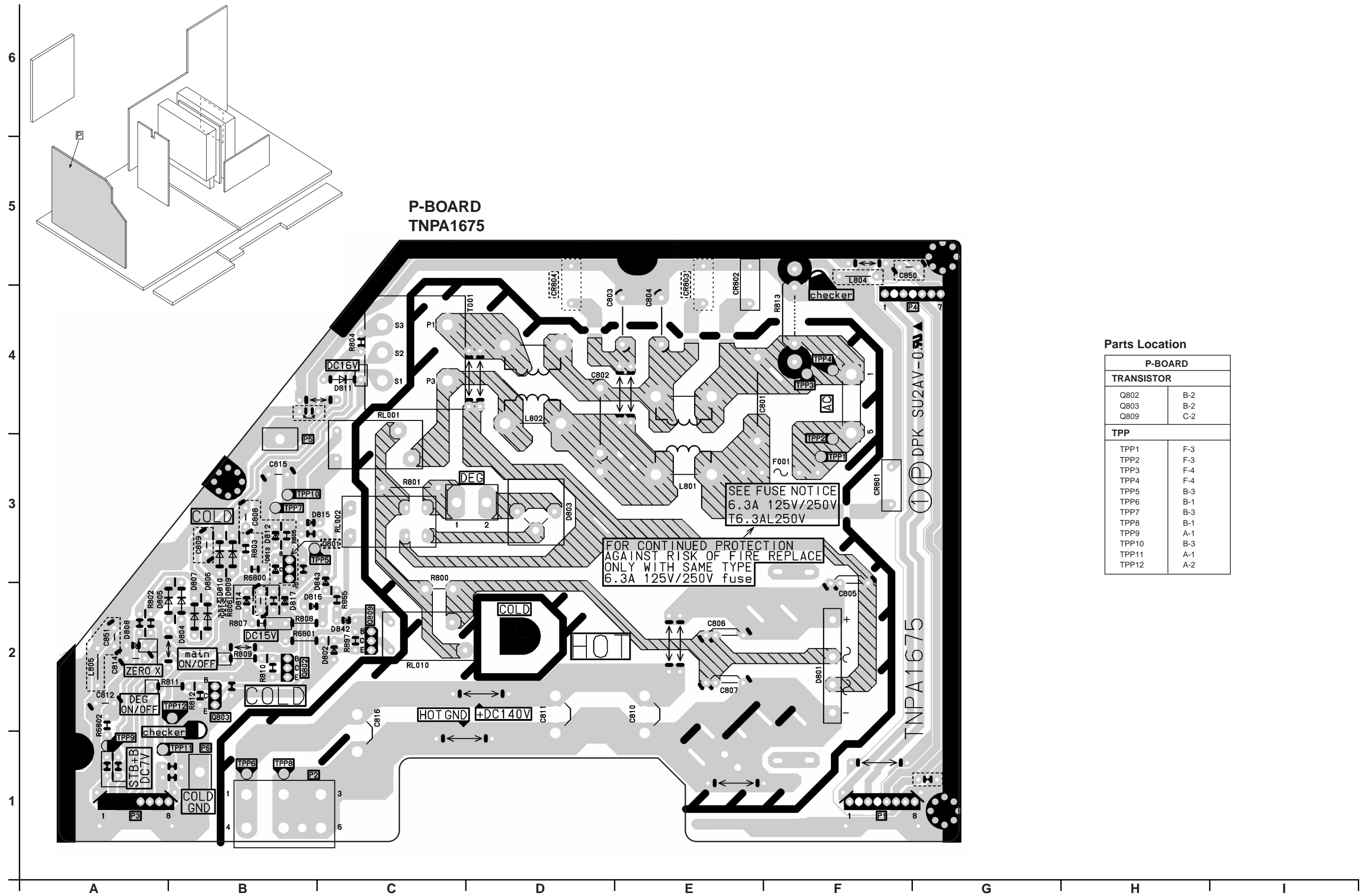

A-BOARD (FOIL SIDE)
TNP0340

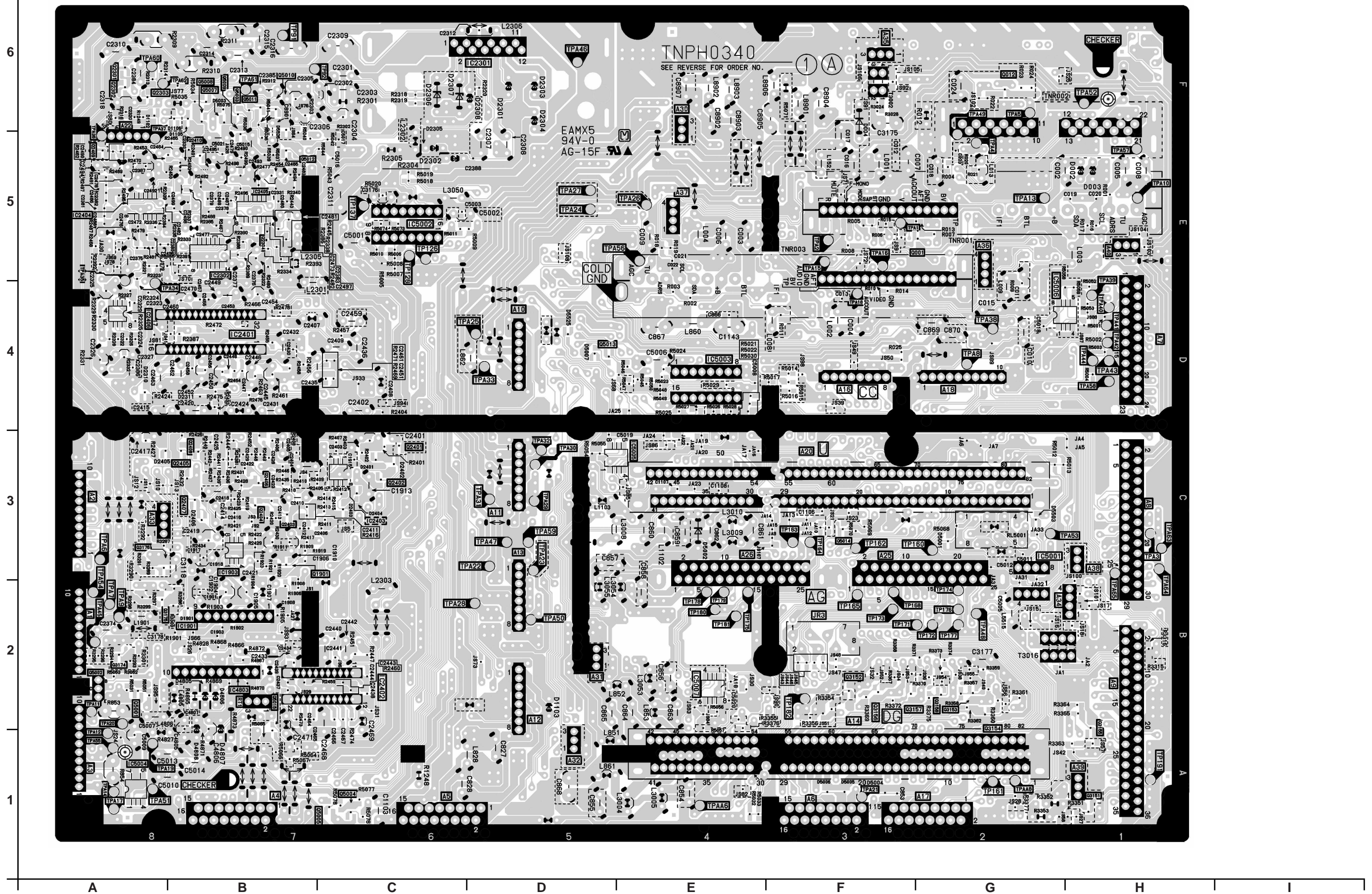

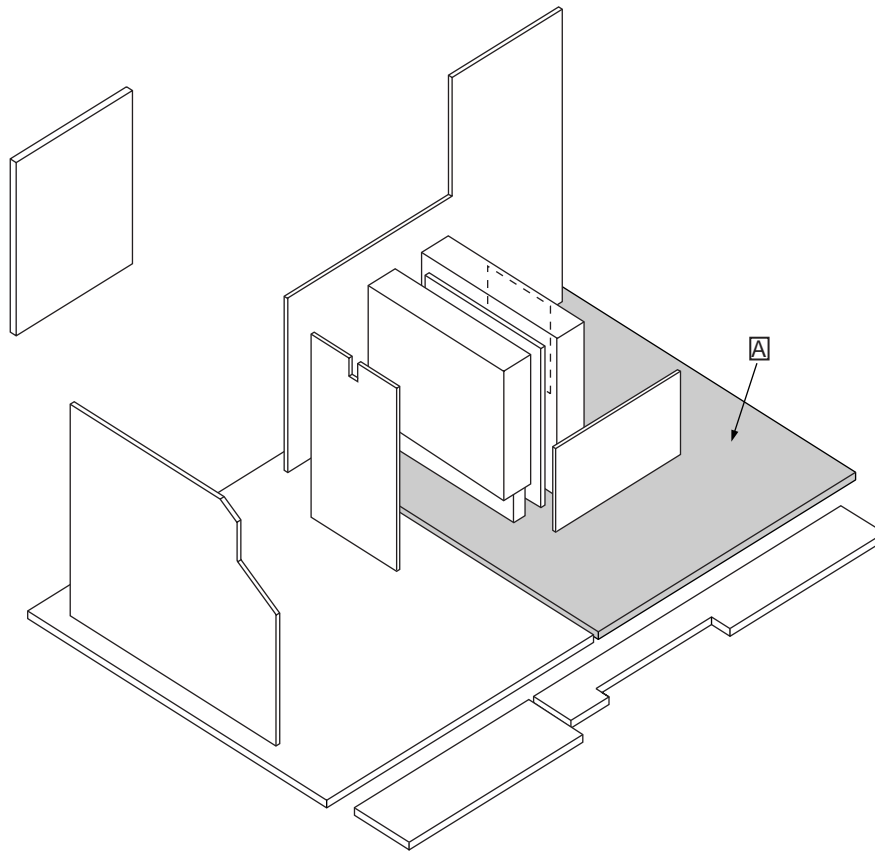

Parts Location

A-BOARD (FOIL SIDE)									
IC		Q3155	H-1	TPA22	D-3	TP			
IC1901	B-2	Q3157	F-2	TPA23	D-3	TP91	B-6		
IC1903	B-3	Q3158	G-2	TPA24	D-5	TP92	B-6		
IC2301	D-6	Q3174	A-2	TPA25	D-4	TP126	C-5		
IC2302	B-5	Q3175	A-2	TPA26	E-5	TP128	C-5		
IC2401	B-4	Q3176	A-3	TPA27	D-5	TP137	C-5		
IC2402	C-2	Q5001	A-2	TPA28	C-2	TP160	F-3		
IC2403	C-3	Q5002	A-2	TPA29	D-3	TP161	G-1		
IC2404	A-5	Q5003	B-6	TPA30	D-3	TP162	F-3		
IC2405	B-5	Q5004	C-1	TPA31	D-3	TP163	F-3		
IC2406	A-4	Q5005	C-1	TPA32	D-3	TP164	F-3		
IC4803	B-2	Q5007	B-6	TPA33	D-4	TP165	F-2		
IC5001	G-3	Q5008	B-6	TPA34	A-4	TP168	F-2		
IC5002	C-5	Q5009	B-6	TPA36	A-5	TP171	F-2		
IC5003	E-4	Q5010	B-6	TPA38	G-4	TP172	G-2		
IC5004	A-1	Q5011	B-6	TPA39	H-4	TP173	F-2		
IC5005	E-3	Q5012	B-5	TPA40	H-4	TP174	G-2		
IC5006	G-4	Q5013	D-4	TPA41	H-4	TP175	E-2		
IC5007	E-2	Q5014	F-3	TPA42	H-4	TP176	G-2		
		Q5015	B-2	TPA43	H-4	TP177	G-2		
TRANSISTOR		TPA		TPA44	H-1	TP178	E-2		
Q001	F-5	TPA1	F-3	TPA45	A-2	TP179	E-2		
Q012	G-6	TPA2	F-5	TPA46	D-6	TP180	E-2		
Q1901	B-3	TPA3	H-3	TPA47	D-3	TP181	E-2		
Q2301	A-6	TPA4	G-5	TPA48	G-2	TP182	F-2		
Q2302	A-6	TPA5	G-6	TPA49	G-6	TP191	H-1		
Q2303	A-6	TPA6	A-3	TPA50	D-2	TPAA			
Q2401	C-3	TPA7	A-2	TPA51	A-1	TPAA6	E-1		
Q2402	C-3	TPA8	G-4	TPA52	H-2	TPAA8	G-1		
Q2403	B-3	TPA9	A-2	TPA53	G-3				
Q2404	B-3	TPA10	H-5	TPA54	A-2				
Q2405	B-3	TPA11	A-2	TPA55	A-1				
Q2406	B-3	TPA12	A-1	TPA56	E-5				
Q2407	B-3	TPA13	G-5	TPA57	H-5				
Q2408	B-3	TPA15	F-5	TPA58	H-4				
Q2409	A-5	TPA16	F-5	TPA59	D-3				
Q2410	B-5	TPA17	A-1	TPA61	B-6				
Q3151	H-1	TPA18	F-4	TPA63	H-3				
Q3152	F-2	TPA19	A-1	TPA65	H-2				
Q3153	G-2	TPA20	A-2	TPA66	H-2				
Q3154	G-1	TPA21	F-1						

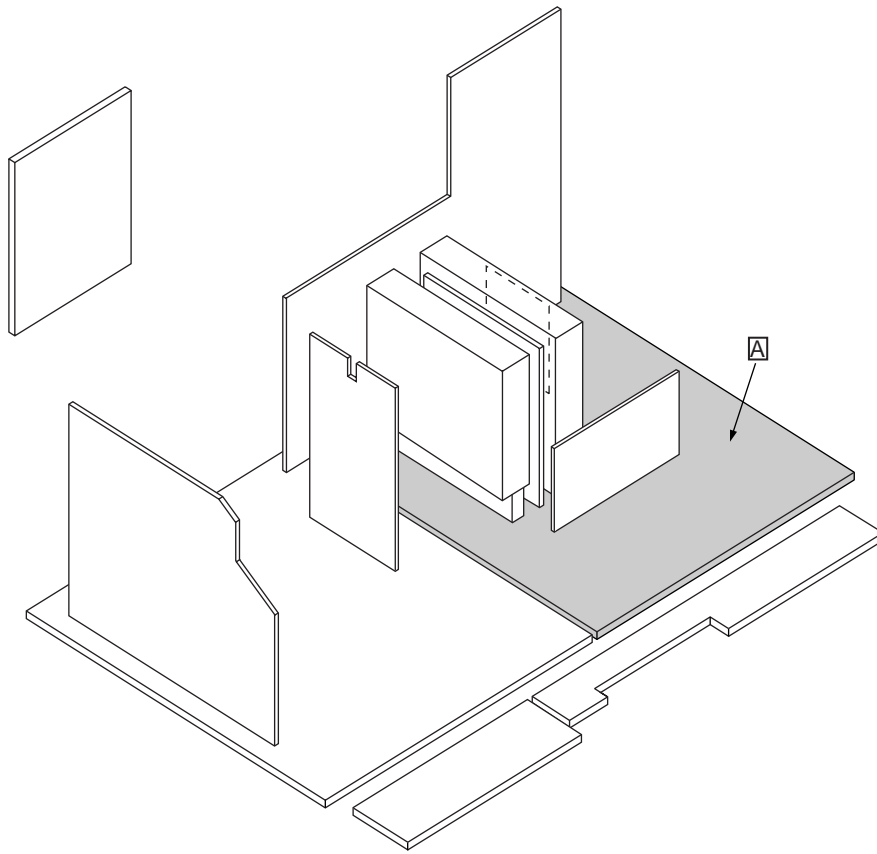

Parts Location

A-BOARD (COMPONENT SIDE)	
IC	
IC1901	G-2
IC2301	E-6
IC2401	H-4
IC2402	F-2
IC4803	G-2
IC5001	B-2
IC5002	F-5
IC5003	D-6
TRANSISTOR	
Q5002	H-2

**A-BOARD (COMPONENT SIDE)
TNPH0340**

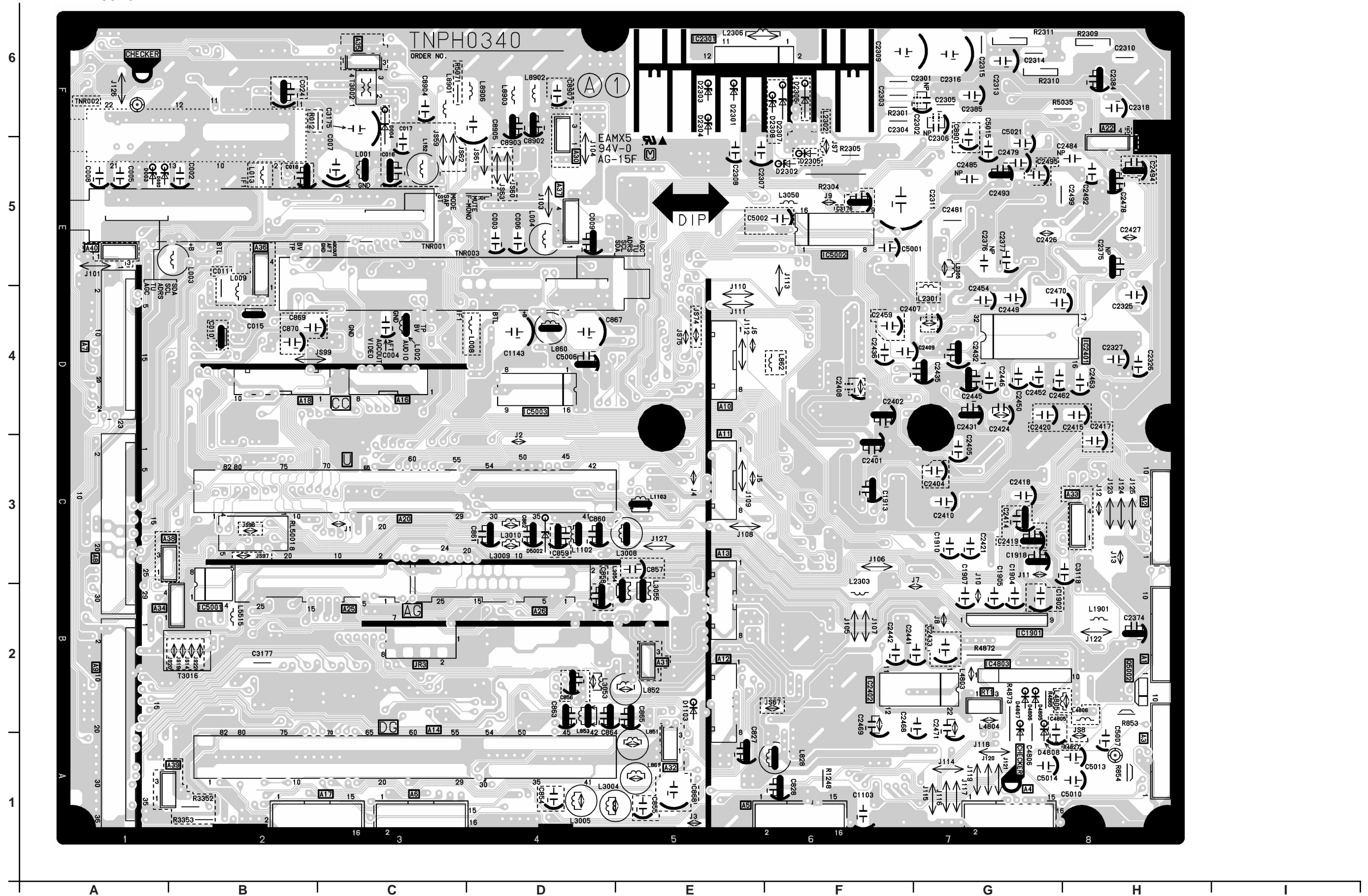

D-BOARD
TZTNP010ERR

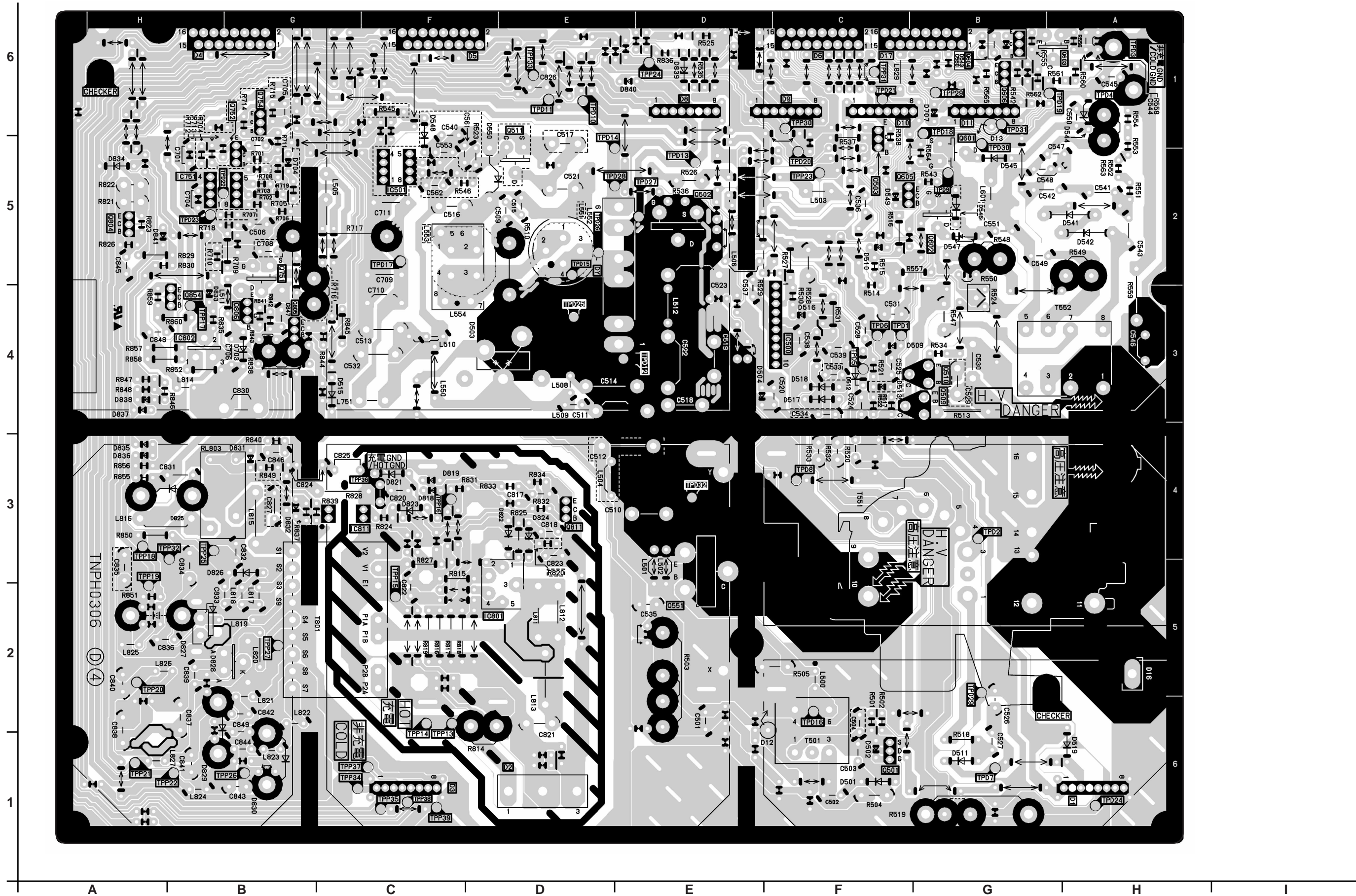

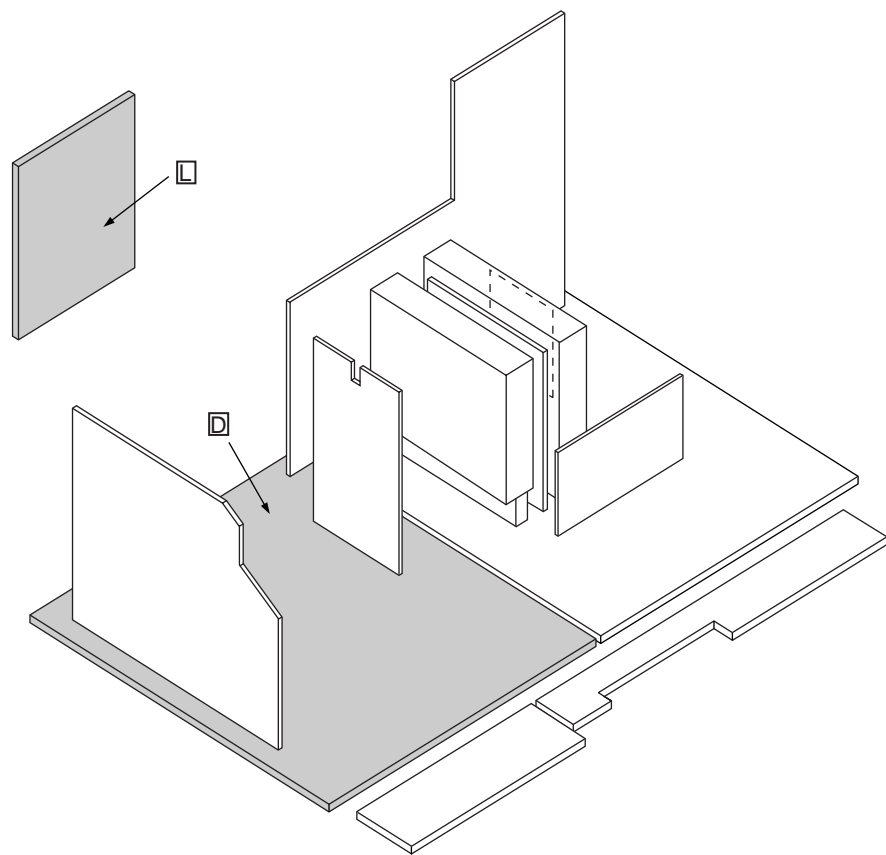

Parts Location

D-BOARD					
IC		TPD		TPP	
IC500	F-4	TPD1	F-4	TPP13	C-1
IC751	B-5	TPD2	G-3	TPP14	C-1
IC801	D-2	TPD3	H-6	TPP15	C-2
IC802	B-4	TPD4	H-6	TPP16	C-3
IC811	C-3	TPD5	F-4	TPP17	B-4
TRANSISTOR					
Q501	F-1	TPD6	F-4	TPP18	A-3
Q502	E-5	TPD7	G-1	TPP19	A-2
Q503	F-5	TPD8	F-3	TPP20	A-2
Q509	G-4	TPD9	G-5	TPP21	A-1
Q510	G-4	TPD10	D-6	TPP22	A-1
Q551	E-2	TPD11	E-4	TPP23	F-5
Q601	G-5	TPD12	E-5	TPP24	E-6
Q602	G-5	TPD13	E-5	TPP25	B-3
Q603	H-6	TPD14	D-5	TPP26	B-1
Q604	G-6	TPD15	D-5	TPP27	B-2
Q605	F-5	TPD16	F-1	TPP28	
Q606	G-6	TPD17	C-5	TPP29	G-6
Q751	B-5	TPD18	G-6	TPP30	F-6
Q804	A-5	TPD19	G-6	TPP31	F-6
Q805	B-4	TPD20	F-5	TPP32	B-3
Q806	B-4	TPD21	F-6	TPP33	D-6
Q811	D-3	TPD22	B-5	TPP34	C-1
Q854	B-4	TPD23	B-5	TPP35	C-1
		TPD24	H-1	TPP36	C-3
		TPD25	D-4	TPP37	C-1
		TPD26	D-5	TPP38	C-1
		TPD27	E-5	TPP39	C-1
		TPD28	D-5		
		TPD29	G-2		
		TPD30	G-5		
		TPD31	G-6		
		TPD32	E-3		

Parts Location

L-BOARD			
IC		TPL	
IC3801	B-3	TPL1	C-3
IC3802	B-1	TPL2	B-2
IC3803	C-3	TPL3	C-2
TRANSISTOR			
Q902	D-1	TPL4	A-3
Q951	D-1	TPL5	A-3
Q952	C-1	TPL6	A-3
Q955	D-3	TPL8	C-2
Q956	E-3	TPL9	C-2
		TPL10	B-2
		TPL11	C-3
		TPL12	B-1
		TPL17	D-1

L-BOARD
TNPA1536AB

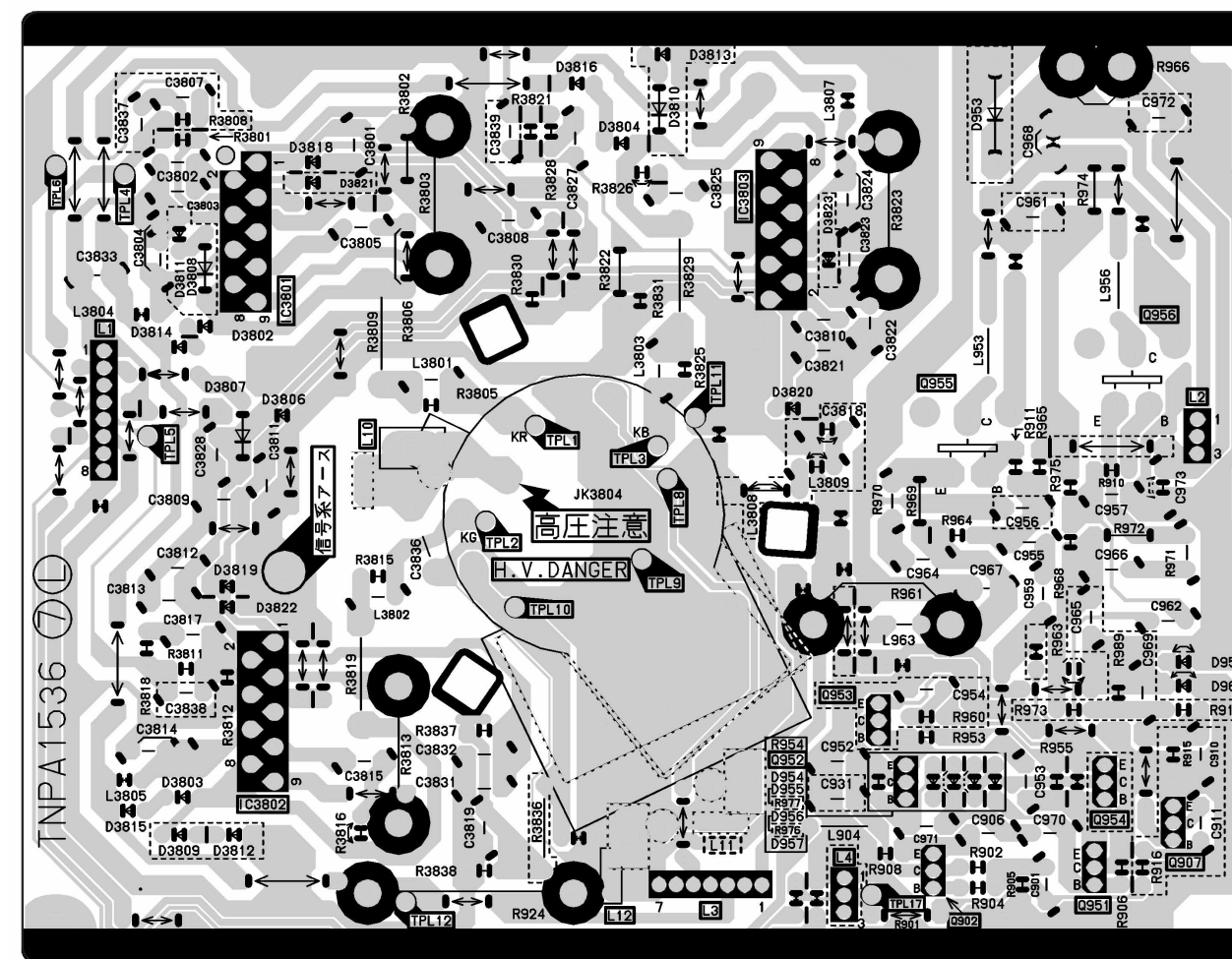

**G-BOARD
TNPA1531AB**

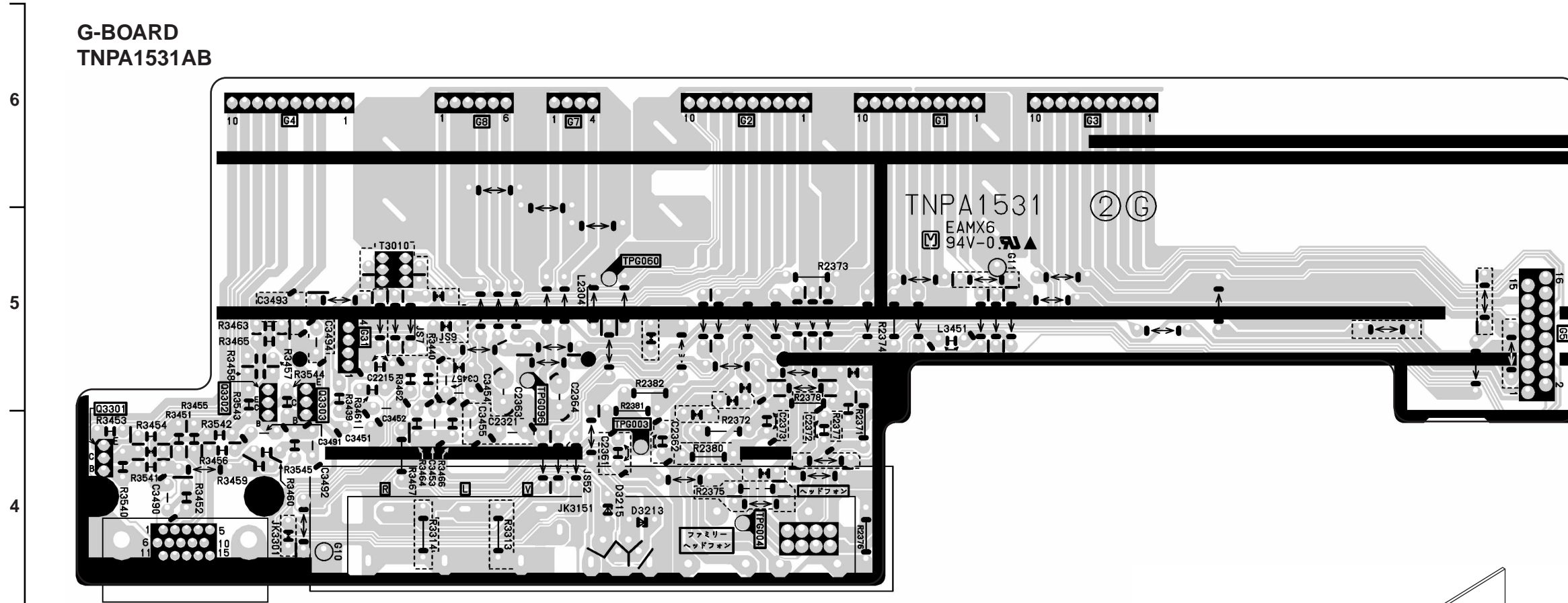

**K-BOARD
TNPA1532**

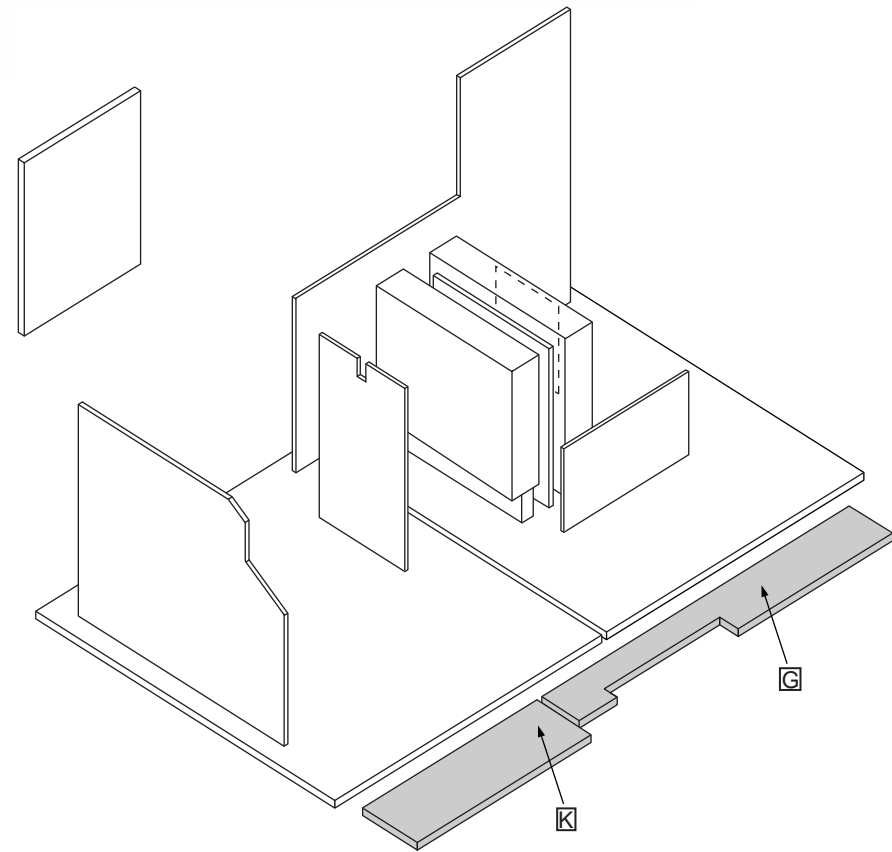
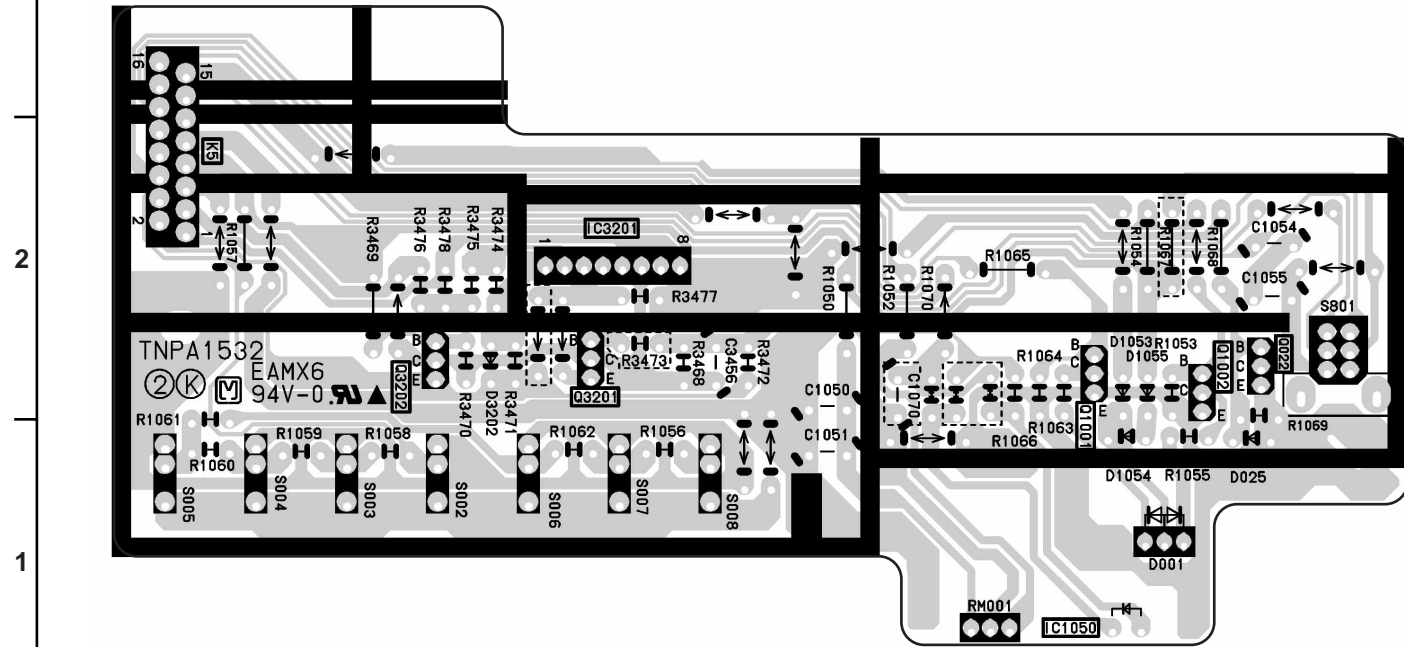

Schematic Diagrams

Schematic Diagram Notice

Important Safety Notice

Components identified by Δ mark have special characteristics important for safety. When replacing any of these components, use only manufacture's specified parts.

Notes:

1. Resistor

All resistors are carbon 1/4W resistor, unless marked as follows:
Unit of resistance is OHM [Ω] (K=1,000, M=1,000,000).

- | | |
|-------------------------|---------------------------|
| \circ : Nonflammable | \boxtimes : Metal Oxide |
| Δ : Solid | \odot : Metal Film |
| \boxplus : Wire Wound | \otimes : Fuse: |

2. Capacitor

All capacitors are ceramic 50V capacitor, unless marked as follows:
Unit of capacitance is μ F, unless otherwise noted.

- | | |
|---|---|
| \otimes : Temperature Compensation | $\text{---} \text{ } \text{---}$: Electrolytic |
| \textcircled{M} : Polyester | $\text{---} \text{ } \text{---}$: Bipolar |
| \textcircled{m} : Metalized Polyester | $\text{---} \text{ } \text{---}$: Dipped Tantalum |
| \boxtimes : Polypropylene | \textcircled{Z} : Z-Type |

3. Coil

Unit of inductance is μ H, unless otherwise noted.

4. Test Point

- \circ : Test Point position

5. Earth Symbol

- | | |
|--|---------------------------------|
| $\text{---} \text{ } \text{---}$: Chassis Earth (Cold) | \downarrow : Line Earth (Hot) |
|--|---------------------------------|

6. Voltage Measurement

Voltage is measured by a DC voltmeter.

Conditions of the measurement are the following:

- | | |
|-------------------------------|---|
| Power Source | AC 120V (PT model)/ 220-240V (TC model) |
| Receiving Signal | Colour Bar signal (RF) |
| All customer's controls | Maximum positions |

7. Number in red circle indicates waveform number.

(See waveform pattern table.)

8. When arrow mark (\nearrow) is found, connection is easily found from the direction of arrow

9. Indicates the major signal flow. : Video \Rightarrow Audio \Leftrightarrow

10. This schematic diagram is the latest at the time of printing and subject to change without notice.

Remarks:

- The Power Circuit contains a circuit area which uses a separate power supply to isolate the earth connection.
The circuit is defined by HOT and COLD indications in the schematic diagram. Take the following precautions.
All circuits, except the Power Circuit, are cold.
Precautions
 - Do not touch the hot part or the hot and cold parts at the same time or you may be shocked.
 - Do not short-circuit the hot and cold circuits or a fuse may blow and parts may break.
 - Do not connect an instrument, such as an oscilloscope, to the hot and cold circuits simultaneously or a fuse may blow.
Connect the earth of instruments to the earth connection of the circuit being measured.
 - Make sure to disconnect the power plug before removing the chassis.
- Following diodes are interchangeable.
MA150- MA162 (Replacement part)

Remote Control Transmitter EUR511162

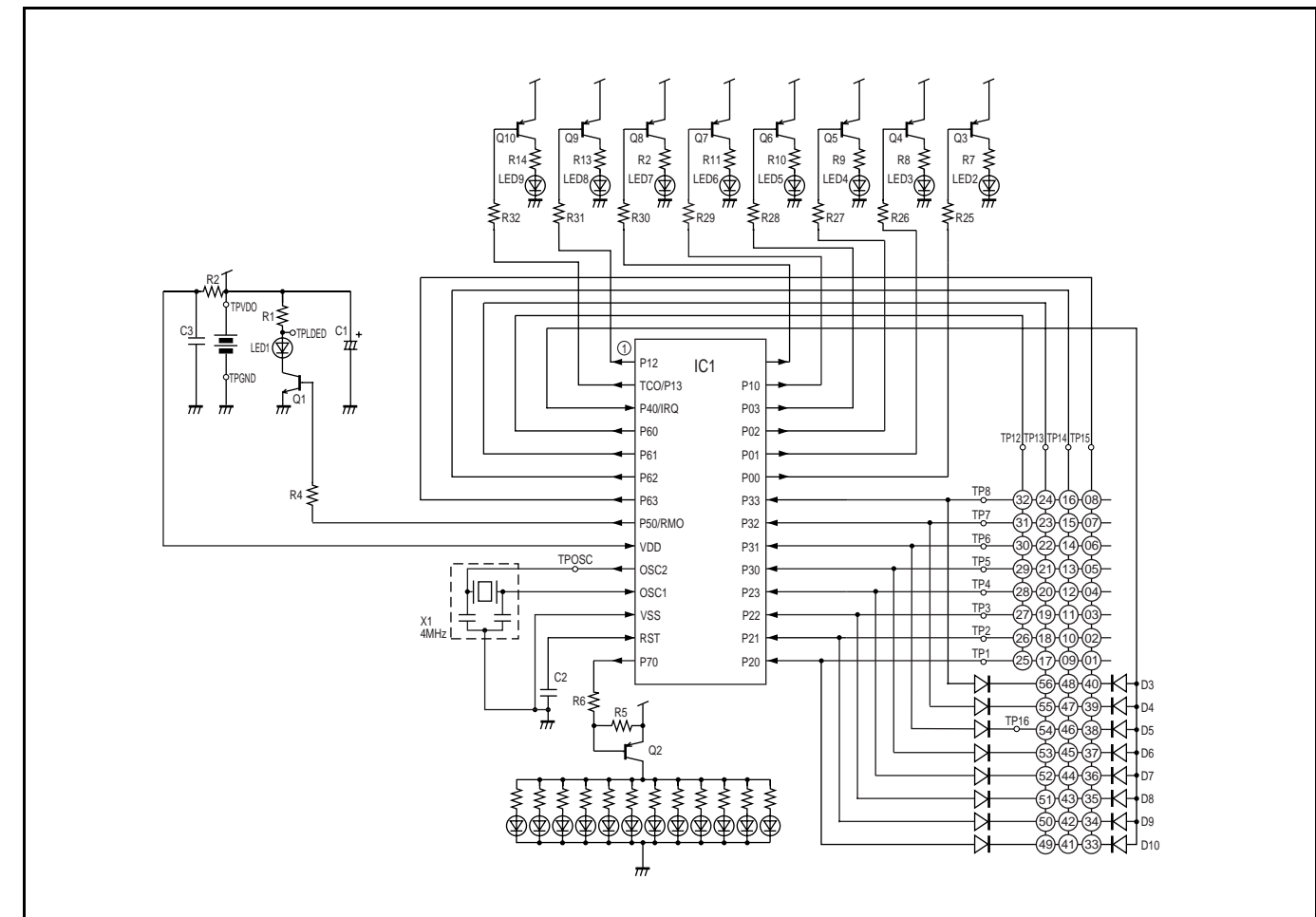

Key Function Table

Key No.	Function	Key No.	Function	Key No.	Function
1	MUTE	17	VOL +	33	R-TUNE
2	STOP	18	ACTION	34	RECORD
3	MENU	19	CHAN UP	35	TV/VCR
4	EXIT	20	LIGHT	36	7
5	TV	21	VOL -	37	4
6	VCR	22	TV/VIDEO	38	1
7	<< (REW)	23	DTV	39	NORMAL
8	VCR/SPLIT	24	INFO/RECALL	40	AV ADJ
9	GUIDE	25	9	41	PROG
10	PLAY	26	6	42	PAUSE
11	>> (FF)	27	CBL	43	---
12	---	28	AUX	44	8
13	DBS	29	ASPECT	45	5
14	RCVR	30	POWER	46	2
15	CHAN DOWN	31	DVD	47	GAME
16	3	32	0	48	RH-SPLIT

A-BOARD TNP0340 (1/4)

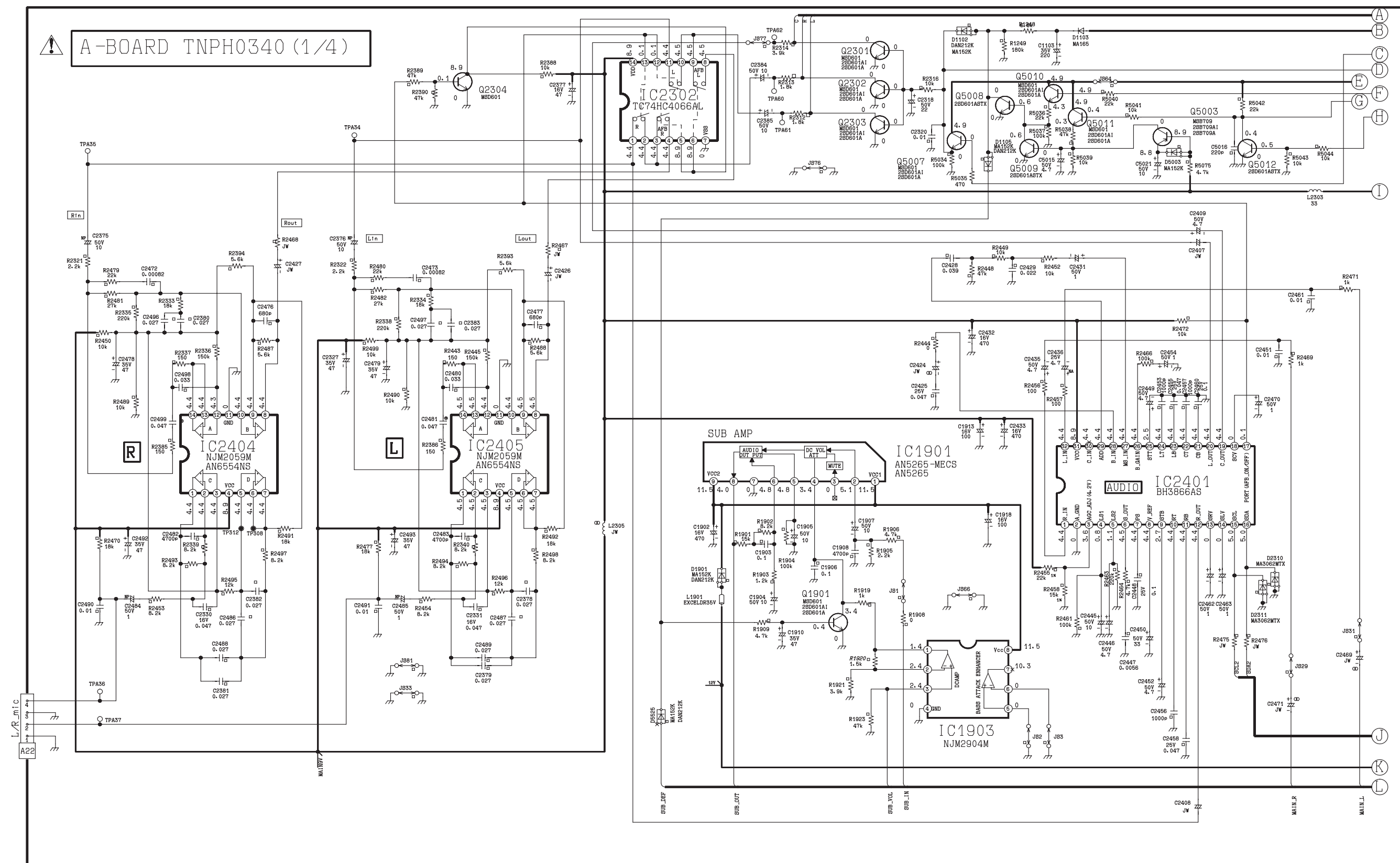

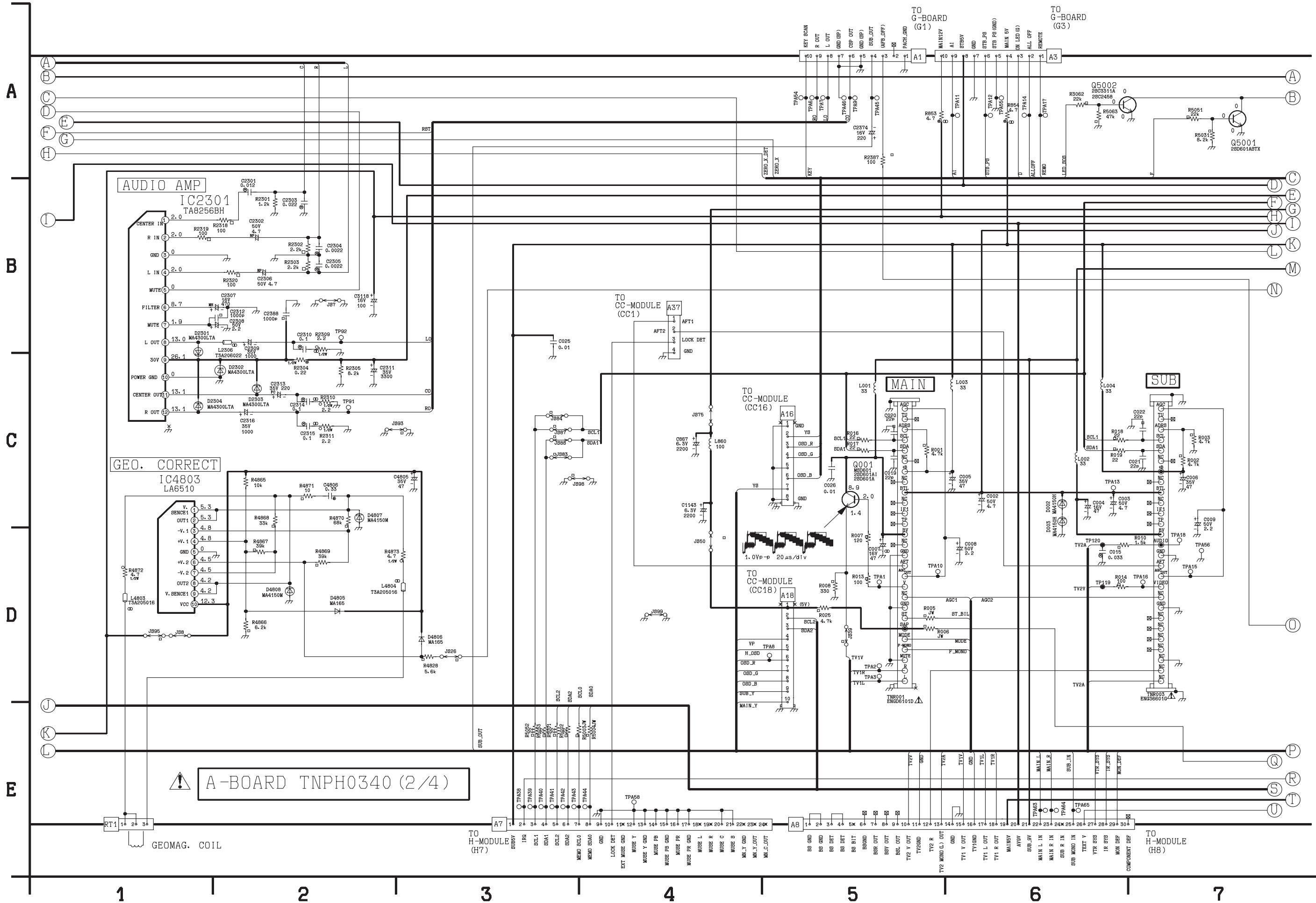

⚠ A-BOARD TNP0340 (2/4)

GEOMAG. COIL

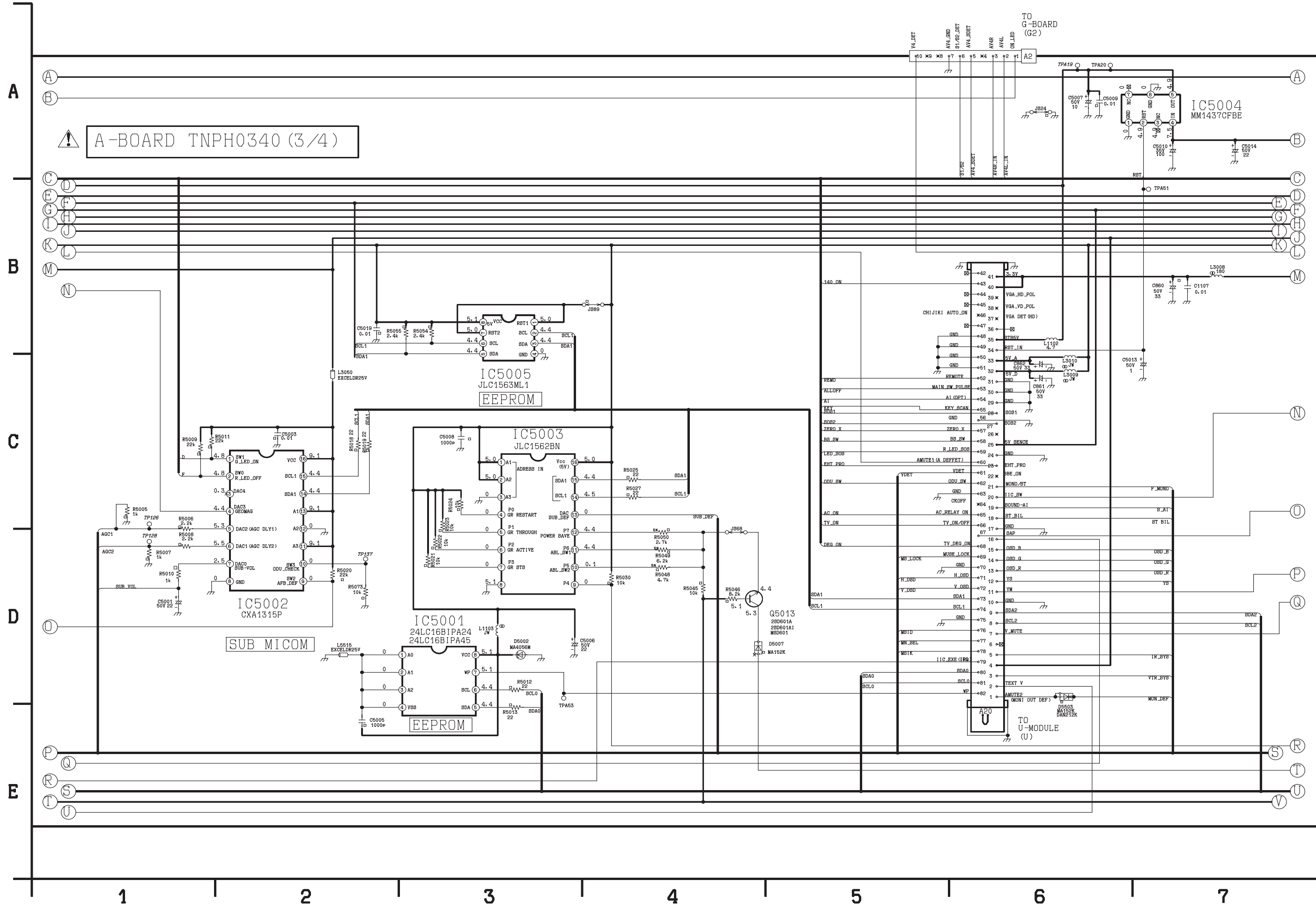

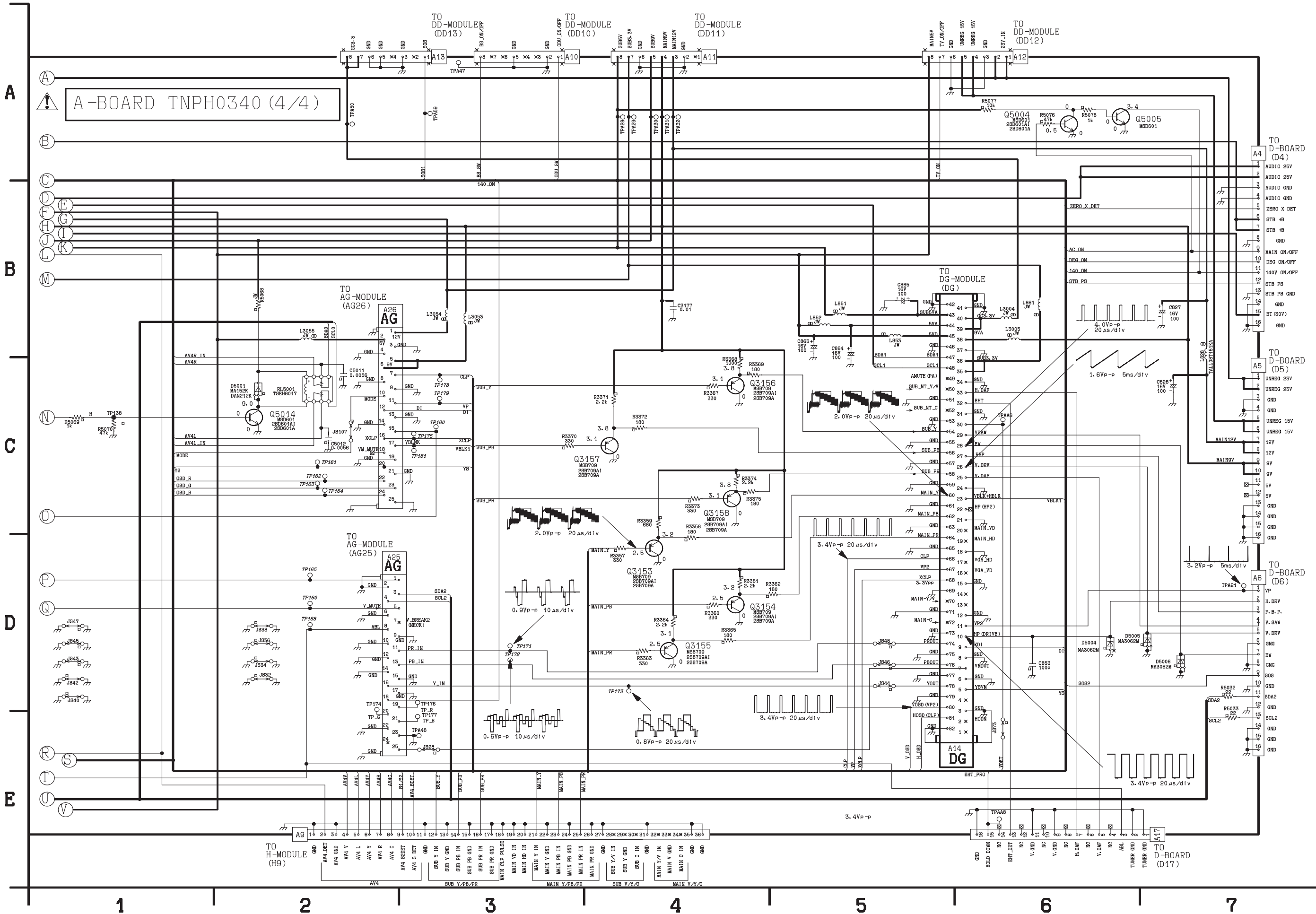

D-BOARD TNP0306AF (1/2)

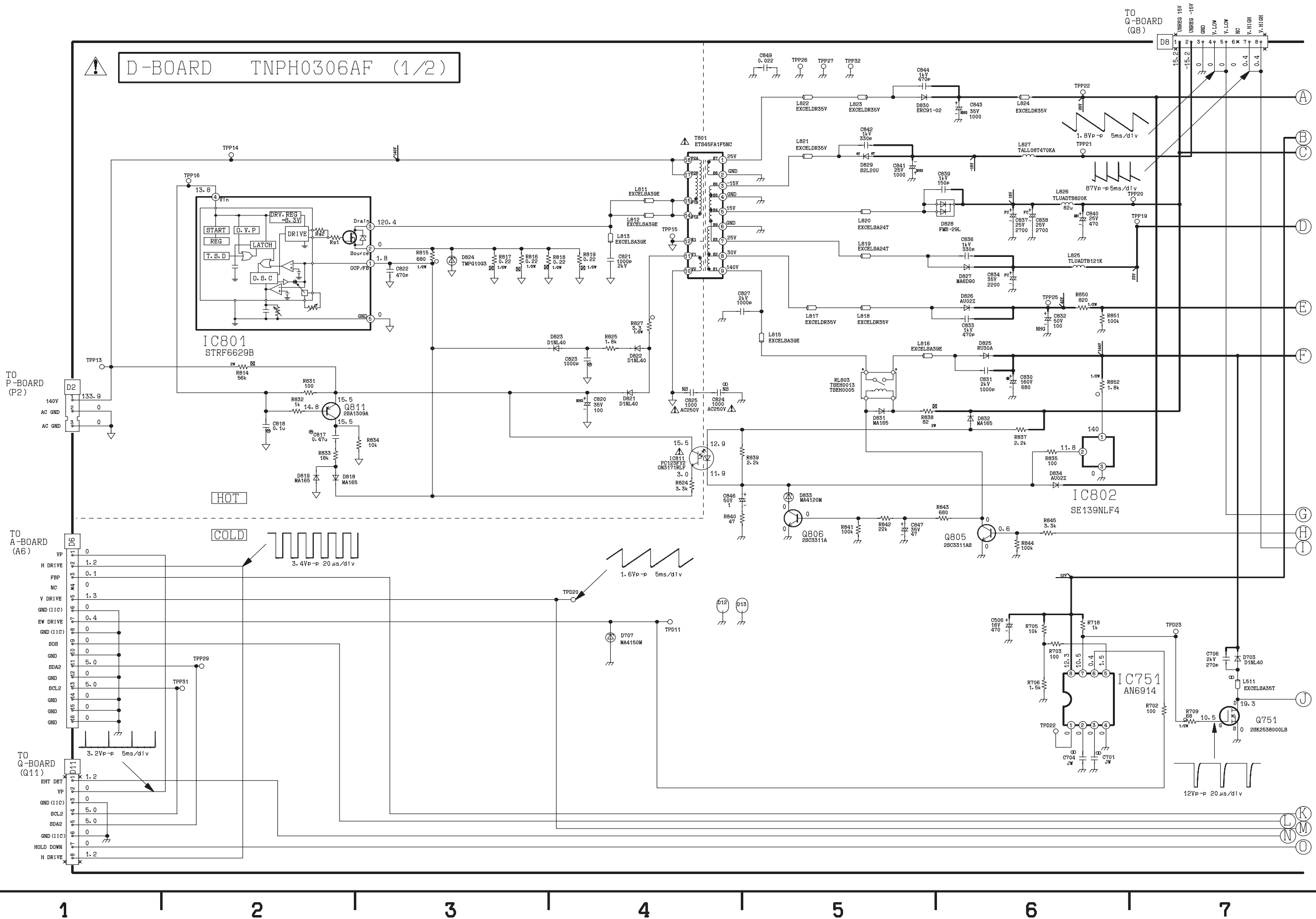

A

B

C

D

E

D-BOARD TNPH0306AF (2/2)

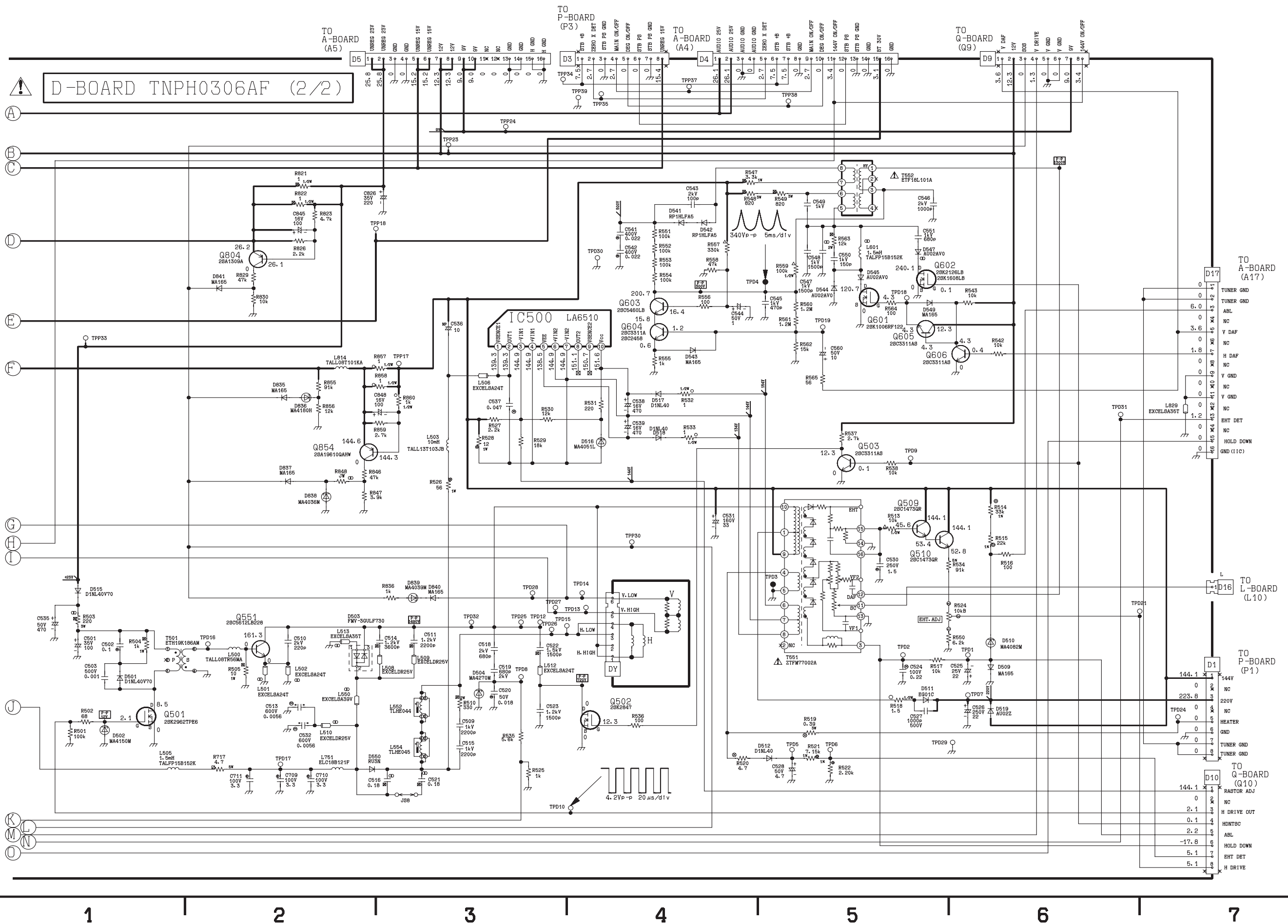

A

B

C

D

E

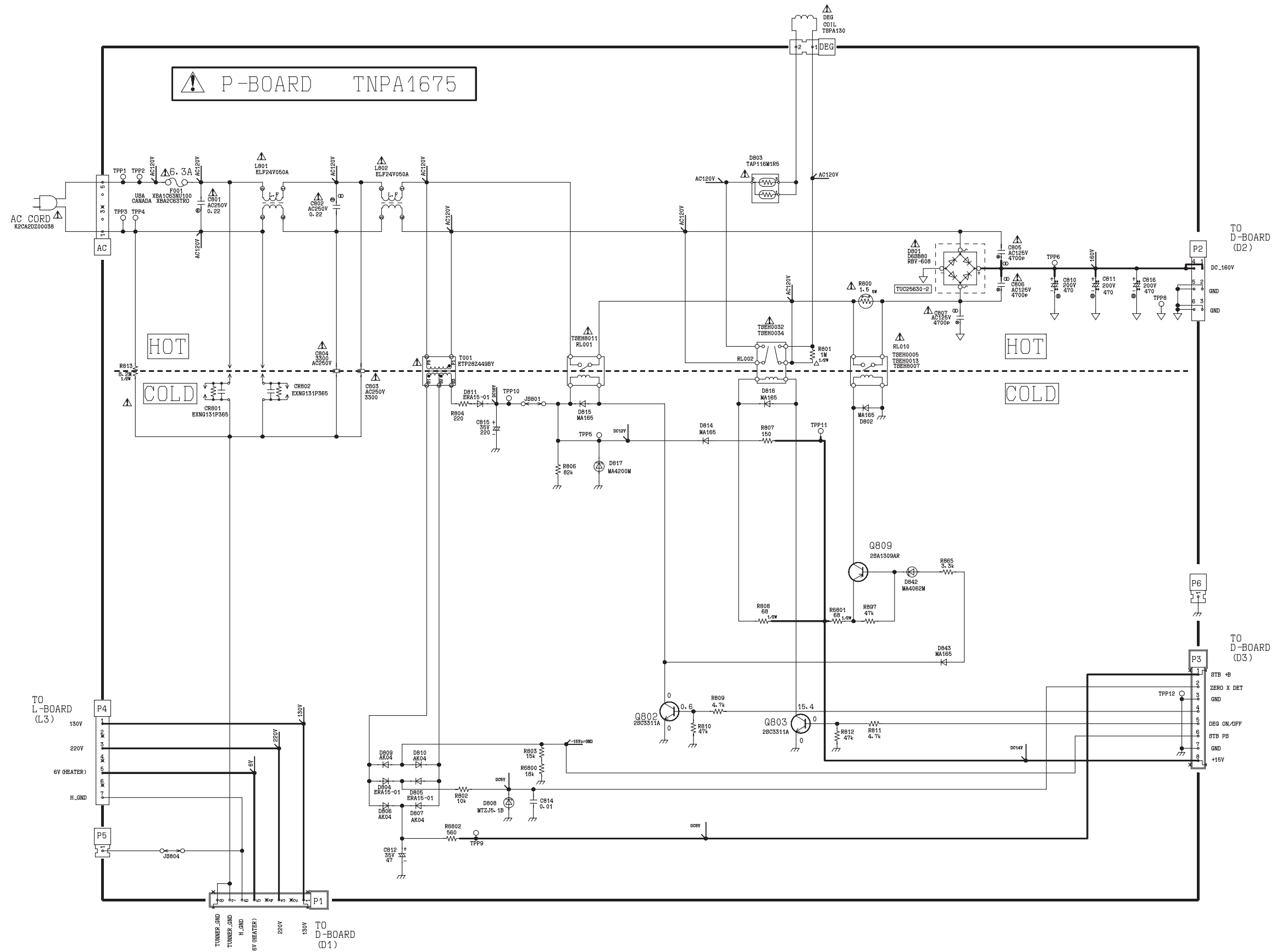

A
B
C
D
E

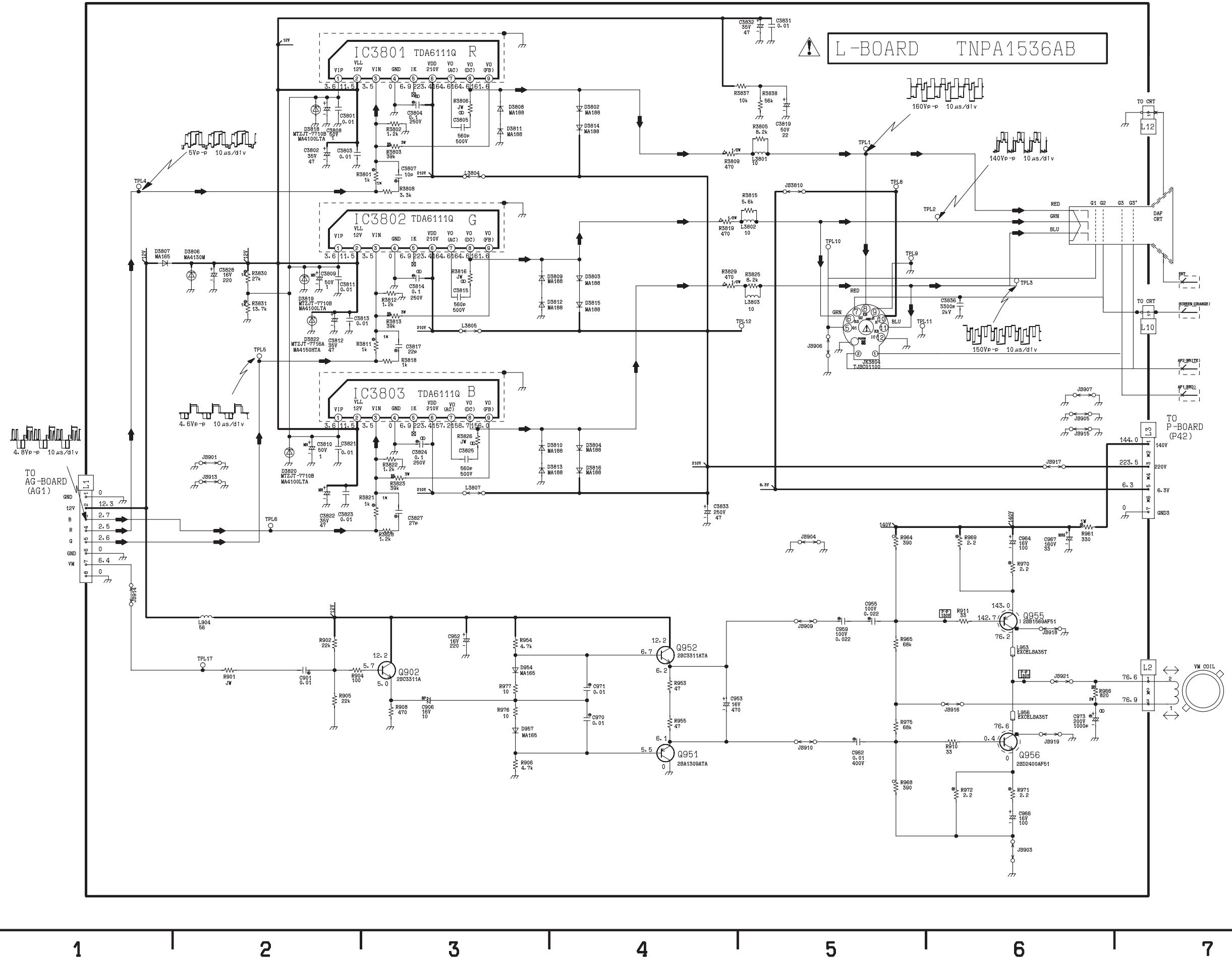

A
B
C
D
E

⚠ K-BOARD
TNPA1532

⚠ G-BOARD TNPA1531

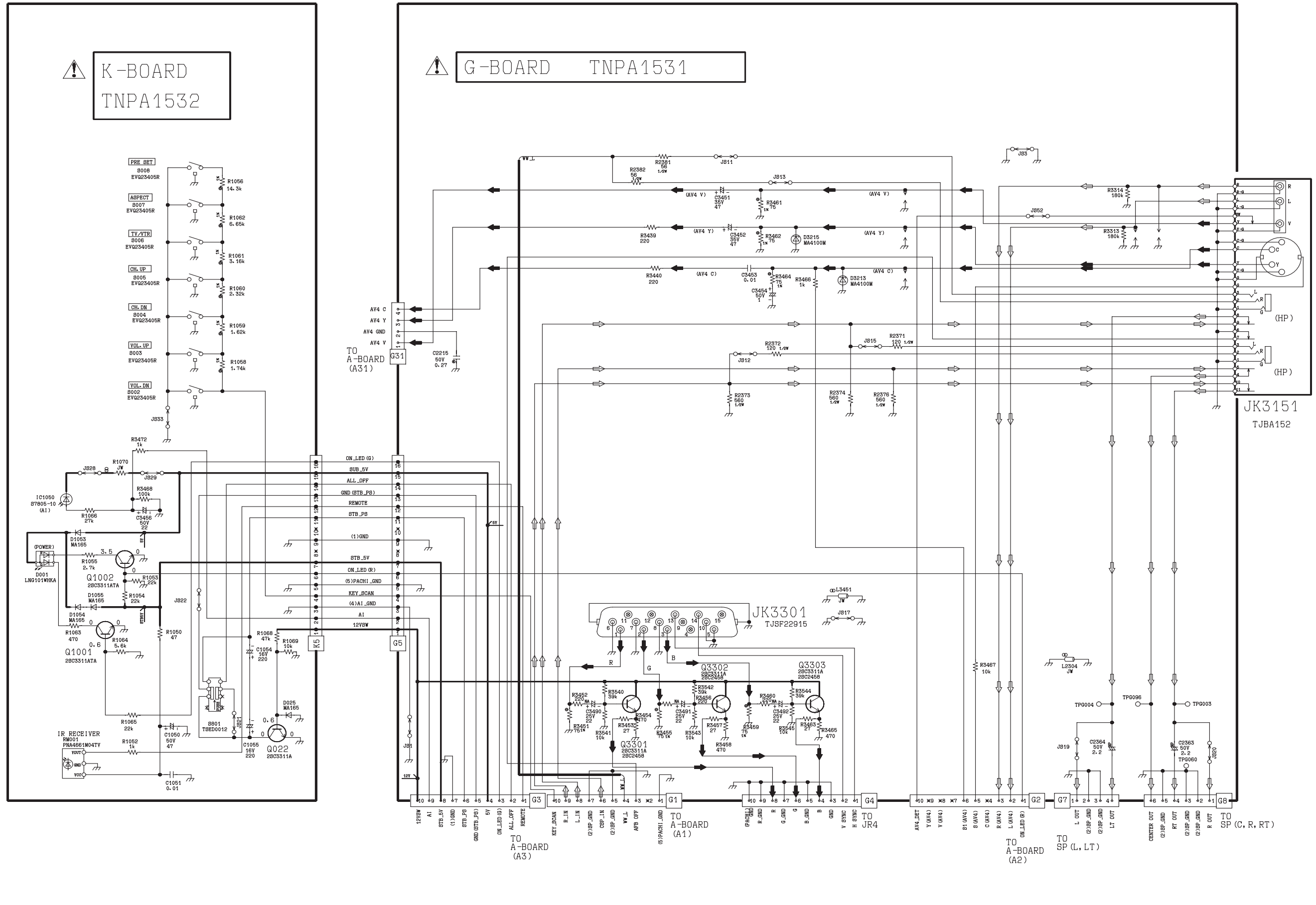

1 2 3 4 5 6 7

Parts Location

Note:

The number on mechanical parts indicates Ref. No. Mechanical Replacement Parts List

• **Front View**

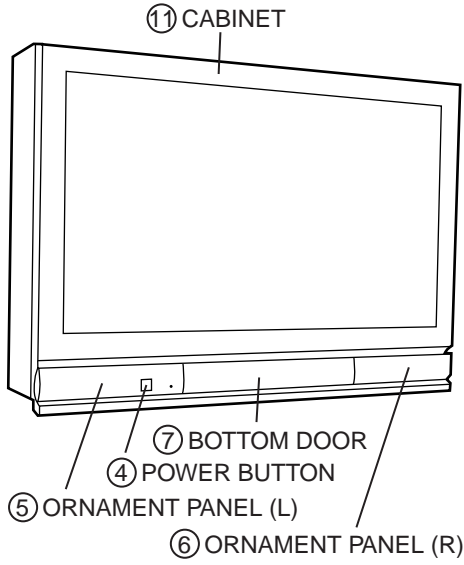

• **Rear View**

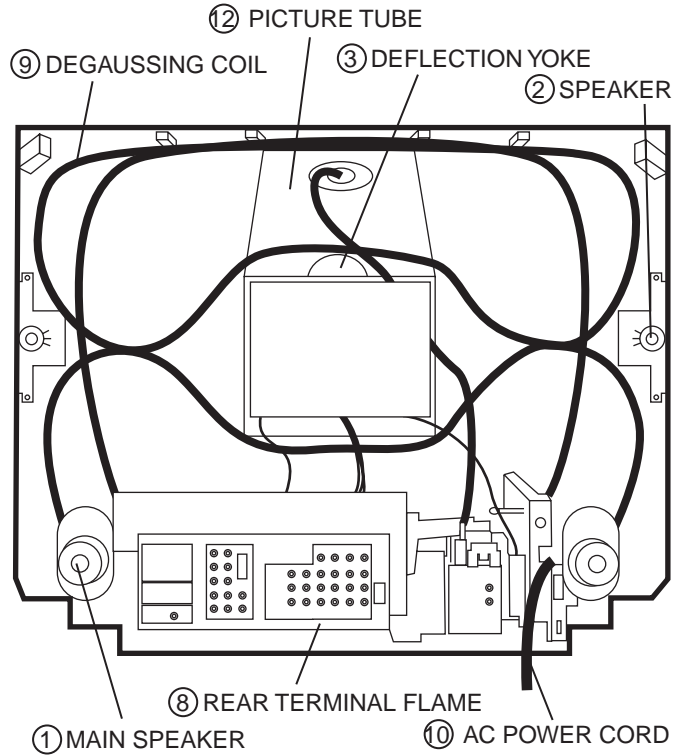

• **Chassis Board Layout View**

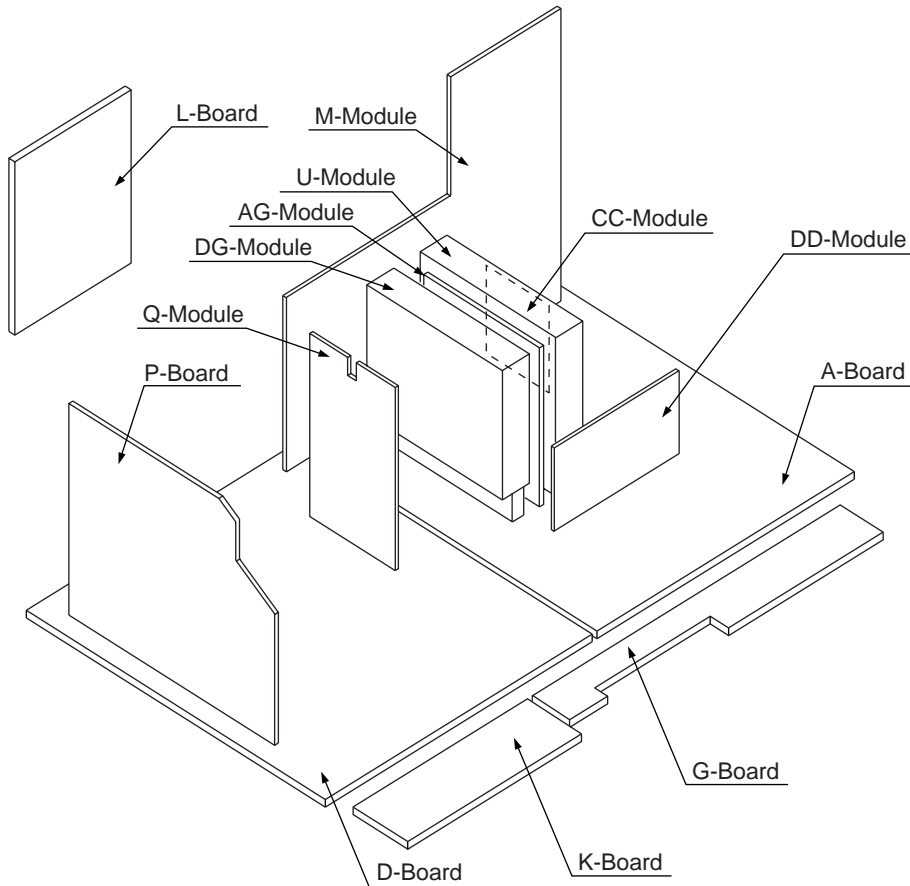

Mechanical Replacement Parts Lists

Ref. No	Part No.	Part Name & Description	Pcs.	Remarks	Ref. No	Part No.	Part Name & Description	Pcs.	Remarks
	TXJA610N92	SPEAKER REED	1						
	TMM76416-1	CLAMPER	1						
	TMM16452	CLAMPER	1						
1	EAB12149B	MAIN SPEAKER	2						
	EAS12D123Y0	SPEAKER (CENTER)	1						
2	EAS13KH14E	SPEAKER (TWEETER)	1						
	EUR511162	TRANSMITTER	1						
3	KDY4WHA64F	DEFLECTION YOKE	1						
	TBMA059	PANASONIC BADGE	1						
△	TBMD890	MODEL NAME PLATE	1	U.S.A.					
△	TBMD897	MODEL NAME PLATE	1	CANADA					
4	TBXA24302	POWER BUTTON	1						
	TEKC001	DAMPER	1						
	TEKC011	DAMPER	1						
	TEKX008	DOOR CATCHER	2						
	TESA031	SPRING	1						
	TES4G204	SPRING	1						
	TES4156	SPRING	1						
	THTA006Z	SCREW	13						
	THTF004Y	SCREW	2						
	THT1062	SCREW	4						
	TJS158010	8P CONNECTOR	2						
	TJS169960	CONNECTOR	2						
	TJS169990	7P CONNECTOR	2						
	TKKL5124	FOCUS COVER	1						
	TKK169777-5	COVER	1						
	TKK169796-1	AC CORD COVER	1						
5	TKPA36104	ORNAMENT PANEL (L)	1						
6	TKPA36205	ORNAMENT PANEL (R)	1						
7	TKPA36504	BOTTOM DOOR	1						
8	TKPA36703	REAR TERMINAL FLAME	1						
	TMME047	CLAMPER	2						
	TMME055	CLAMPER	4						
	TMME097	CLAMPER	1						
	TMMJ032	DY WEDGE	4						
	TMM15404-1	SPACER RING	2						
	TMM16497-1	CLAMPER	2						
	TMWA017	BRACKET	1						
	TMWJ019	BRACKET	1						
	TMXA029	PRINT HOLDER	1						
	TMZK5003	SPEAKER HOLDER(TWEETER)	1						
	TPCA85103	CARTON BOX	1						
	TPCA85201	CARTON BOX (BOTTOM)	1						
	TPDA0376	CUSHION (UPPER)	1						
	TPDA0377	CUSHION (BOTTOM)	1						
	TPDA0382	CUSHION (RGHIT SPACER)	1						
	TPDA0383	CUSHION (LEFT SPACER)	1						
	TPDA0378	CUSHION (REAR)	1						
	TPD169487	JOINT	6						
	TPEH007-3	SET COVER	1						
	TPEH033	PROTECT COVER	1						
△	TQBC0213	INSTRUCTION BOOK	1	ENGLISH					
△	TQBC0214	INSTRUCTION BOOK	1	FRENCH					
	TSM10032-1	MAGNET	3						
	TSN63115-4	MAGNET	4						
△	9 TSPA130	DEGAUSSING COIL	1						
△	10 K2CB2DZ00002	AC POWER CORD	1						
△	TTPA0144	BOTTOM DOOR	1						
△	TTUA0364	REAR COVER	1	U.S.A.					
△	TTUA0365	REAR COVER	1	CANADA					
△	11 TTYA0411	CABINET	1						
	TUAA02103E	CHASSIS FLAME	1						
△	12 W86LPX955X	PICTURE TUBE	1						
	XTBT964	SCREW	10						
	XTB4+12A	SCREW	1						
	XTB4+15AFZ	SCREW	6						
	XTV3+10G	SCREW	2						
	XTV3+12G	SCREW	10						
	XTV3+6J	SCREW	2						
	XTW3+10T	SCREW	11						
	XTW3+8T	SCREW	4						
	XYN3+F10	SCREW	2						
	XYN3+F12	SCREW	1						
	XYN3+F6	SCREW	3						
	XYN3+F8	SCREW	6						
	XZBT6506	POLY BAG	1						

Replacement Parts List

Important Safety Notice

Components identified by Δ mark have special characteristics important for safety. When replacing any of these components, use only manufacturer's specified parts.

RTL (Retention Time Limited)

Note: The marking (RTL) indicates that the Retention Time is Limited for this item. After the discontinuation of this assembly in production, the item will continue to be available for a specific period of time. The retention period of availability is dependant on the type of assembly, and in accordance with the laws governing part and product retention. After the end of this period, the assembly will no longer be available.

Abbreviation of part name and description

1. Resistor

Example:

ERD25TJ104 C 100KOHM, J, 1/4W
 Type Allowance

2. Capacitor

Example:

ECKF1H103ZF C 0.01UF, Z, 50V
 Type Allowance

Type	Allowance
C : Carbon	F : $\pm 1\%$
F : Fuse	G : $\pm 2\%$
M : Metal Oxide Metal Film	J : $\pm 5\%$
S : Solid	K : $\pm 10\%$
W : Wire Wound	M : $\pm 20\%$

Type	Allowance
C : Ceramic	C : $\pm 0.25\text{pF}$
E : Electrolytic	D : $\pm 0.5\text{pF}$
P : Polyester	F : $\pm 1\text{pF}$
Polyprop lene	G : $\pm 3\text{pF}$
T : Tantalum	J : $\pm 5\text{pF}$
	K : $\pm 10\text{pF}$
	L : $\pm 15\text{pF}$
	M : $\pm 20\text{pF}$
	P : +100%, -0%
	Z : +80%, -20%

Ref. No	Part No.	Part Name & Description	Pcs.	Remarks
A1-A3	TJS5A9190	10P CONNECTOR	3	
A4-A6	TJSF20016	16P CONNECTOR	3	
A7	TJS3A8980	24P CONNECTOR	1	
A8	TJS3A9110	30P CONNECTOR	1	
A9	TJS3A8960	36P CONNECTOR	1	
A10-13	TJS5A9420	8P CONNECTOR	4	
A14	TJSF51382	CONNECTOR	1	
A16	TJS5A9420	8P CONNECTOR	1	
A17	TJSF20016	16P CONNECTOR	1	
A18	TJS6A8160	10P CONNECTOR	1	
A20	TJSF35282	CONNECTOR	1	
A22	TJS3A9650	4P CONNECTOR	1	
A25,26	TJSF17325	25P CONNECTOR	2	
A34	TJS3A9650	4P CONNECTOR	1	
A37	TJS3A9650	4P CONNECTOR	1	
AC	TJS3A9630	CONNECTOR	1	
C002,03	ECA1HM4R7	E 4.7UF, 50V	2	
C004	ECA1CM470	E 47UF, 16V	1	
C005,06	ECA1VM470	E 47UF, 35V	2	
C007	ECA1CM470	E 47UF, 16V	1	
C008,09	ECA1HM2R2	E 2.2UF, 50V	2	
C015	ECQB1H333JF	P 0.033UF, J, 50V	1	
C019-22	ECJ2XC1H220J	C 22UF, J, 50V	4	
C501	ECA1VM101	E 100UF, 35V	1	
C502	ECQV1H104JM	P 0.1UF, J, 50V	1	
C503	ECKD2H102KB2	C 1000PF, K, 500V	1	
C506	ECA1CM471	E 470UF, 16V	1	
C509	ECKD3A222KBP	C 2200PF, K, 1KV	1	
C510	ECKD3D221KBN	C 220PF, K, 2KV	1	
C511	ECWH16222JVY	P 2200UF, J, 1.6KV	1	
C513	ECQF6562JZ	P 5600PF, J, 630V	1	
C514	ECWH16362JVY	P 3600UF, J, 1.6KV	1	
C515	ECKD3A222KBP	C 2200PF, K, 1KV	1	
C516	ECWF2184JSR	P 0.18UF, J, 250V	1	
C518,19	ECKD3D681KBN	C 680PF, K, 2KV	2	
C520	ECQB1H183JF	P 0.018UF, J, 50V	1	
C521	ECWF2184JSR	P 0.18UF, J, 250V	1	
C522	ECWH20152JVY	P 1500UF, J, 2KV	1	
C523	ECWH16152JVY	P 1500UF, J, 1.6KV	1	
C524	ECQB1224JF	P 0.22UF, J, 100V	1	
C525	EEUNA1E220	E 22UF, 25V	1	
C526	ECA2EM220	E 22UF, 250V	1	
C527	ECKD2H102KB2	C 1000PF, K, 500V	1	
C528	ECA1HM4R7	E 4.7UF, 50V	1	
C530	ECQE2155JF	P 1.5UF, J, 250V	1	
C531	ECA160V33U	E 33UF, 160V	1	
C532	ECQF6562JZ	P 5600PF, J, 630V	1	
C535	ECA1HM471	E 470UF, 50V	1	
C536	ECEA1HN100U	E 10UF, 50V	1	
C537	ECQB1H473JF	P 0.047UF, J, 50V	1	
C538,39	ECA1CM471	E 470UF, 16V	2	
C541,42	ECQM4223KZ	P 0.022UF, K, 400V	2	
C543	ECKD3D101KBP	C 100PF, K, 2KV	1	
C544	ECA1HM010	E 1UF, 50V	1	
C545	ECKD3A471KBP	C 470PF, K, 1KV	1	
C546	ECKD3D102KBP	C 1000PF, K, 2KV	1	
C547,48	ECKD3A152KBP	C 1500PF, K, 1KV	2	
C549	ECKD3A681KBP	C 680PF, K, 1KV	1	
C550	ECKD3A151KBP	C 150PF, K, 1KV	1	
C551	ECKD3A681KBP	C 680PF, K, 1KV	1	
C560	ECA1HM100	E 10UF, 50V	1	
C706	ECKD3D271KBP	C 270PF, K, 2KV	1	
C709-11	ECQE1335KF	P 3.3UF, K, 100V	3	
△ C801,02	ECQU2A224MN	P 0.22UF, M, 250V	2	
△ C803,04	ECKCWS332MEB	C 3300PF, M,	2	
C805-07	ECKD2H472PU7	C 4700PF, P, 500V	3	
C810,11	EC0S2DA471BB	E 470UF, 200V	2	
C812	ECA1VM470	E 47UF, 35V	1	
C814	ECKF1H103ZF	C 0.01UF, Z, 50V	1	
C815	ECA1VM221	E 220UF, 35V	1	
C816	EC0S2DA471BB	E 470UF, 200V	1	
C817	ECQV1H474JM	P 0.47UF, J, 50V	1	
C818	ECQV1H104JM	P 0.1UF, J, 50V	1	
C820	ECA1VHG101	E 100UF, 35V	1	
C821	ECKD3D102KBP	C 1000PF, K, 2KV	1	
C822	ECKF1H471KB	C 470PF, K, 50V	1	
C823	ECQB1H102JF	P 1000PF, J, 50V	1	
△ C824,25	ECKDNB102MB	C 1000PF,	2	
C826	ECA1VM221	E 220UF, 35V	1	
C827	ECA1CM101	E 100UF, 16V	1	
C827	ECKD3D102KBP	C 1000PF, K, 2KV	1	
C828	ECA1CM101	E 100UF, 16V	1	
C830	EETHC2C681B	E 680UF, 160V	1	

Ref. No	Part No.	Part Name & Description	Pcs.	Remarks
C831	ECKD3D102KBP	C 1000PF, K, 2KV	1	
C832	ECA1HHG101	E 100UF, 50V	1	
C833	ECKD3A471KBP	C 470PF, K, 1KV	1	
C834	EEUFC1V222	E 2200UF, 35V	1	
C836	ECKD3A331KBP	C 330PF, K, 1KV	1	
C837,38	EEUFC1E272	E 2700UF, 25V	2	
C839	ECKD3A151KBP	C 150PF, K, 1KV	1	
C840	ECA1EMH471	E 470UF, 25V	1	
C841	ECA1EHG102	E 1000UF, 25V	1	
C842	ECKD3A331KBP	C 330PF, K, 1KV	1	
C843	ECA1VHG102	E 1000UF, 35V	1	
C844	ECKD3A471KBP	C 470PF, K, 1KV	1	
C845	ECA1CM101	E 100UF, 16V	1	
C846	ECA1HM010	E 1UF, 50V	1	
C847	ECA1VM470	E 47UF, 35V	1	
C848	ECA1CM101	E 100UF, 16V	1	
C849	ECKF1H223ZF	C 0.022UF, Z, 50V	1	
C853	ECJ2XC1H101K	C 100PF, K, 50V	1	
C860-62	ECA1HM330	E 33UF, 50V	3	
C863-65	ECA1CM101	E 100UF, 16V	3	
C867	ECA0JM222	E 2200UF, 6.3V	1	
C901	ECQB1H103JF	P 0.01UF, J, 50V	1	
C906	ECEA1CN100U	E 10UF, 16V	1	
C952	ECA1CM221	E 220UF, 16V	1	
C953	ECA1CM471	E 470UF, 16V	1	
C955	ECQB1223KF	P 0.022UF, K, 100V	1	
C959	ECQB1223KF	P 0.022UF, K, 100V	1	
C962	ECQM4103KZ	P 0.01UF, K, 400V	1	
C964	ECA1CM101	E 100UF, 16V	1	
C966	ECA1CM101	E 100UF, 16V	1	
C967	ECA2CHG330	E 33UF, 160V	1	
C970,71	ECQB1H103JF	P 0.01UF, J, 50V	2	
C973	ECQM2102KZ	P 1000PF, K, 200V	1	
C1050	ECA1HM470	E 47UF, 50V	1	
C1051	ECKF1H103ZF	C 0.01UF, Z, 50V	1	
C1054,55	ECA1CM221	E 220UF, 16V	2	
C1103	ECA1VM221	E 220UF, 35V	1	
C1107	ECJ2XB1H103K	C 0.01UF, K, 50V	1	
C1143	ECA0JM222	E 2200UF, 6.3V	1	
C1902	ECA1CM471	E 470UF, 16V	1	
C1903	ECJ2VF1H104Z	C 0.1UF, Z, 50V	1	
C1904,05	ECA1HM100	E 10UF, 50V	2	
C1906	ECJ2VF1H104Z	C 0.1UF, Z, 50V	1	
C1907	ECA1HM100	E 10UF, 50V	1	
C1908	ECJ2XB1H472K	C 4700PF, K, 50V	1	
C1910	ECA1VM470	E 47UF, 35V	1	
C1913	ECA1CM101	E 100UF, 16V	1	
C1918	ECA1CM101	E 100UF, 16V	1	
C2215	ECQV1H274JM	P 0.27UF, J, 50V	1	
C2301	ECQB1H123JF	P 0.012UF, J, 50V	1	
C2302	ECEA1HN4R7U	E 4.7UF, 50V	1	
C2303	ECQB1H223JF	P 0.022UF, J, 50V	1	
C2304,05	ECQB1H222JF	P 2200PF, J, 50V	2	
C2306	ECEA1HN4R7U	E 4.7UF, 50V	1	
C2307	ECA1CMH471	E 470UF, 16V	1	
C2308	ECA1HM2R2	E 2.2UF, 50V	1	
C2309	ECA1VM102	E 1000UF, 35V	1	
C2310	ECQV1H104JM	P 0.1UF, J, 50V	1	
C2311	ECA1VM332	E 3300UF, 35V	1	
C2312	ECJ2XC1H102J	C 1000PF, J, 50V	1	
C2313	EEUFC1V221	E 220UF, 35V	1	
C2314,15	ECQV1H104JM	P 0.1UF, J, 50V	2	
C2316	ECA1VM102	E 1000UF, 35V	1	
C2318	ECA1HM220	E 22UF, 50V	1	
C2320	ECJ2XB1H103K	C 0.01UF, K, 50V	1	
C2327	ECA1VM470	E 47UF, 35V	1	
C2330,31	ECJ2VB1E473K	C 0.047UF, K, 25V	2	
C2363,64	ECA50YT2R2K	E 2.2UF, 50V	2	
C2374	ECA1CM221	E 220UF, 16V	1	
C2375,76	ECEA1HN100U	E 10UF, 50V	2	
C2377	ECA1CM470	E 47UF, 16V	1	
C2378-83	ECJ2VB1H273K	C 0.027UF, K, 50V	6	
C2384,85	ECA1HM100	E 10UF, 50V	2	
C2388	ECJ2XB1H102K	C 1000PF, K, 50V	1	
C2409	ECA1HM4R7	E 4.7UF, 50V	1	
C2425	ECJ2VB1E473K	C 0.047UF, K, 25V	1	
C2428	ECJ2VB1H393K	C 0.039UF, K, 50V	1	
C2429	ECJ2XB1H223K	C 0.022UF, K, 50V	1	
C2431	ECA1HM010	E 1UF, 50V	1	
C2432,33	ECA1CM471	E 470UF, 16V	2	
C2435	ECA1HM4R7	E 4.7UF, 50V	1	
C2436	EEANA1E4R7	E 4.7UF, 25V	1	
C2445	ECA1HM100	E 10UF, 50V	1	
C2446	ECA1HM4R7	E 4.7UF, 50V	1	
C2447	ECJ2XB1H562K	C 5600PF, K, 50V	1	

Ref. No	Part No.	Part Name & Description	Pcs.	Remarks	Ref. No	Part No.	Part Name & Description	Pcs.	Remarks
C2448	ECJ2VB1E104K	C 0.1UF, K, 25V	1		D8-11	TJS5A9420	8P CONNECTOR	4	
C2449	ECA1HM4R7	E 4.7UF, 50V	1		D17	TJSF19916	16P CONNECTOR	1	
C2450	ECA1HM330	E 33UF, 50V	1		D025	MA165	DIODE	1	
C2451	ECJ2XB1H103K	C 0.01UF, K, 50V	1		D501	D1NL40V70	DIODE	1	
C2452	ECA1HM4R7	E 4.7UF, 50V	1		D502	MA4150M	ZENER DIODE	1	
C2453	ECJ2XC1H102J	C 1000PF, J, 50V	1		D503	FMV-3GU	DIODE	1	
C2454	ECA1HM010	E 1UF, 50V	1		D504	MA4270M	ZENER DIODE	1	
C2455	ECJ2VB1E473K	C 0.047UF, K, 25V	1		D509	MA165	DIODE	1	
C2456,57	ECJ2XC1H102J	C 1000PF, J, 50V	2		D510	MA4082M	ZENER DIODE	1	
C2458	ECJ2VB1E473K	C 0.047UF, K, 25V	1		D511	EG01C	DIODE	1	
C2460	ECJ2VB1E104K	C 0.1UF, K, 25V	1		D512	D1NL40V70	DIODE	1	
C2461	ECJ2XB1H103K	C 0.01UF, K, 50V	1		D515	D1NL40V70	DIODE	1	
C2462,63	ECA1HM010	E 1UF, 50V	2		D516	MA4051L	ZENER DIODE	1	
C2470	ECA1HM010	E 1UF, 50V	1		D517,18	D1NL40V70	DIODE	2	
C2472,73	ECJ2XC1H821J	C 820PF, J, 50V	2		D519	AU02Z	DIODE	1	
C2476,77	ECJ2XB1H681K	C 680PF, K, 50V	2		D541,42	RP1H	DIODE	2	
C2478,79	ECA1VM470	E 47UF, 35V	2		D543	MA165	DIODE	1	
C2480	ECJ2VB1H333K	C 0.033UF, K, 50V	1		D544,45	AU02A	DIODE	2	
C2481	ECQB1H473JF	P 0.047UF, J, 50V	1		D549	MA165	DIODE	1	
C2482,83	ECJ2XB1H472K	C 4700PF, K, 50V	2		D550	TVSRU3N	DIODE	1	
C2484,85	ECEA1HN010U	E 1UF, 50V	2		D703	D1NL40V70	DIODE	1	
C2486-89	ECJ2VB1H273K	C 0.027UF, K, 50V	4		D707	MA4150M	ZENER DIODE	1	
C2490,91	ECJ2XB1H103K	C 0.01UF, K, 50V	2		△ D801	RBV-608	DIODE	1	
C2492,93	ECA1VM470	E 47UF, 35V	2		D802	MA165	DIODE	1	
C2496,97	ECJ2VB1H273K	C 0.027UF, K, 50V	2		△ D803	TAP116M1R5	THERMISTOR	1	
C2498	ECJ2VB1H333K	C 0.033UF, K, 50V	1		D804,05	ERA15-01	DIODE	2	
C2499	ECQB1H473JF	P 0.047UF, J, 50V	1		D806,07	AK04	DIODE	2	
C3451,52	ECA1VM470	E 47UF, 35V	2		D808	MTZJ5.1B	ZENER DIODE	1	
C3453	ECKF1H103ZF	C 0.01UF, Z, 50V	1		D809,10	AK04	DIODE	2	
C3454	ECA1HM010	E 1UF, 50V	1		D811	ERA15-01	DIODE	1	
C3456	ECA1HM220	E 22UF, 50V	1		D814-16	MA165	DIODE	3	
C3801	ECKF1H103ZF	C 0.01UF, Z, 50V	1		D817	MA4200M	ZENER DIODE	1	
C3802	ECA1VM470	E 47UF, 35V	1		D818,19	MA165	DIODE	2	
C3803	ECKF1H103ZF	C 0.01UF, Z, 50V	1		D821-23	D1NL40V70	DIODE	3	
C3804	ECQE2104KF	P 0.1UF, K,250V	1		D824	TMPG10G3	DIODE	1	
C3805	ECKD2H561KB2	C 560PF, K,500V	1		D825	RU30A	DIODE	1	
C3807	ECCF1H100DC	C 10PF, D, 50V	1		D826	AU02Z	DIODE	1	
C3808	ECA1HM010	E 1UF, 50V	1		D827	MA6D90	DIODE	1	
C3809,10	ECA1HM010	E 1UF, 50V	2		D828	FMB-29L	DIODE	1	
C3811	ECKF1H103ZF	C 0.01UF, Z, 50V	1		D829	S2L20U	DIODE	1	
C3812	ECA1VM470	E 47UF, 35V	1		D830	ERC91-02	DIODE	1	
C3813	ECKF1H103ZF	C 0.01UF, Z, 50V	1		D831,32	MA165	DIODE	2	
C3814	ECQE2104KF	P 0.1UF, K,250V	1		D833	MA4120M	ZENER DIODE	1	
C3815	ECKD2H561KB2	C 560PF, K,500V	1		D834	AU02Z	DIODE	1	
C3817	ECCF1H220JC	C 22PF, J, 50V	1		D835	MA165	DIODE	1	
C3819	ECA1HM220	E 22UF, 50V	1		D836	MA4180H	ZENER DIODE	1	
C3821	ECKF1H103ZF	C 0.01UF, Z, 50V	1		D837	MA165	DIODE	1	
C3822	ECA1VM470	E 47UF, 35V	1		D838	MA4036M	ZENER DIODE	1	
C3823	ECKF1H103ZF	C 0.01UF, Z, 50V	1		D839	MA4039M	ZENER DIODE	1	
C3824	ECQE2104KF	P 0.1UF, K,250V	1		D840,41	MA165	DIODE	2	
C3825	ECKD2H561KB2	C 560PF, K,500V	1		D842	MA4062M	ZENER DIODE	1	
C3827	ECCF1H270JC	C 27PF, J, 50V	1		D843	MA165	DIODE	1	
C3828	ECA1CM221	E 220UF, 16V	1		D954	MA165	DIODE	1	
C3831	ECKF1H103ZF	C 0.01UF, Z, 50V	1		D957	MA165	DIODE	1	
C3832	ECA1VM470	E 47UF, 35V	1		D1053-55	MA165	DIODE	3	
C3833	ECA2EM470	E 47UF, 250V	1		D1102	MA152K	DIODE	1	
C3836	ECKD3D332KBN	C 3300PF, K, 2KV	1		D1103	MA165	DIODE	1	
C3938	ECJ2XC1H221J	C 220PF, J, 50V	1		D1105	MA152K	DIODE	1	
C3939-41	TCUY1C105ZFN	C 1UF, 16V	3		D1901	MA152K	DIODE	1	
C3942	ECJ2XC1H331J	C 330PF, J, 50V	1		D2301-04	MA4300L	ZENER DIODE	4	
C3943	ECJ2XC1H471J	C 470PF, J, 50V	1		D2310,11	MA3062M	ZENER DIODE	2	
C4869	ECJ1VC1H080C	C 8PF, C, 50V	1		D3213	MA4100M	ZENER DIODE	1	
C5001	ECA1HM220	E 22UF, 50V	1		D3215	MA4100M	ZENER DIODE	1	
C5003	ECJ2XB1H103K	C 0.01UF, K, 50V	1		D3802-04	MA188	DIODE	3	
C5005	ECJ2XC1H102J	C 1000PF, J, 50V	1		D3806	MA4130M	ZENER DIODE	1	
C5006	ECA1HM220	E 22UF, 50V	1		D3807	MA165	DIODE	1	
C5007	ECA1HM100	E 10UF, 50V	1		D3808-16	MA188	DIODE	9	
C5008	ECJ2XB1H102K	C 1000PF, K, 50V	1		D3818-20	MTZJ10B	ZENER DIODE	3	
C5009	ECJ2XB1H103K	C 0.01UF, K, 50V	1		D3822	MTZJ16A	ZENER DIODE	1	
C5010	ECA1VM101	E 100UF, 35V	1		D4805,06	MA165	DIODE	2	
C5011,12	ECJ2XB1H562K	C 5600PF, K, 50V	2		D4807,08	MA4150M	ZENER DIODE	2	
C5013	ECA1HM010	E 1UF, 50V	1		D5001	MA152K	DIODE	1	
C5014	ECA1HM220	E 22UF, 50V	1		D5002	MA4056M	ZENER DIODE	1	
C5015	ECA1HM4R7	E 4.7UF, 50V	1		D5003	MA152K	DIODE	1	
C5016	ECJ2XC1H221J	C 220PF, J, 50V	1		D5004-06	MA3062M	ZENER DIODE	3	
C5019	ECJ2XB1H103K	C 0.01UF, K, 50V	1		D5007	MA152K	DIODE	1	
C5021	ECA1HM100	E 10UF, 50V	1						
△CR801,02	EXNG131P365	C-R COMBINATION	2		△ F001	XBA1C63NU100	FUSE 125V 6.3A	1	U.S.A.
					△ F001	XBA2C63TR0	FUSE 250V 6.3A	1	CANADA
D001	LNG101WHKA	DIODE	1		F001-L	EYF-52BC	FUSE HOLDER	1	
D1	TJS5A9420	8P CONNECTOR	1		F001-R	EYF-52BC	FUSE HOLDER	1	
D002,03	MA4150H	ZENER DIODE	2						
D3	TJS5A9420	8P CONNECTOR	1						
D4-D6	TJSF19916	16P CONNECTOR	3		G1-G3	TJS5A9180	10P PLUG	3	

Ref. No	Part No.	Part Name & Description	Pcs.	Remarks
G5	TJSF19916	16P CONNECTOR	1	
G7	TJS3A9650	4P CONNECTOR	1	
G8	TJS3A9670	6P CONNECTOR	1	
G31	TJS3A9650	4P CONNECTOR	1	
IC500	LA6510	LINEAR IC	1	
IC751	AN6914	LINEAR IC	1	
IC801	STRF6629B	IC	1	
IC802	SE139N	LINEAR IC	1	
△ IC811	PC123FY2	PHOTO COUPLER	1	
IC1050	S7805-10	IC	1	
IC1901	AN5265	LINEAR IC	1	
IC1903	NJM2904M	LINEAR IC	1	
IC2301	TA8256BH	LINEAR IC	1	
IC2302	TC74HC4066AF	MOS IC (CMOS S/LOGIC)	1	
IC2401	BH3866AS	LINEAR IC	1	
IC2404,05	NJM2059M	LINEAR IC	2	
IC3801-03	TDA6111Q	LINEAR IC	3	
IC4803	LA6510	LINEAR IC	1	
IC5001	TVRJ372	IC (EEPROM 16KBIT)	1	
IC5002	CXA1315P	LINEAR IC	1	
IC5003	JLC1562BN	MOS IC (MICON LSI)	1	
IC5004	MM1437CFBE	IC	1	
IC5005	JLC1563ML1	MOS IC	1	
JA28	ERJ6GEY0R00	M 0 OHM,J,1/10W	1	
JA30-33	ERJ6GEY0R00	M 0 OHM,J,1/10W	4	
JK3151	TJBA152	FRONT TERMINAL	1	
△ JK3804	TJSC01100	CRT SOCKET	1	
JS52	ERDS2TJ221	C 220 OHM, J,1/4W	1	
JS64	ERJ6GEY0R00	M 0 OHM,J,1/10W	1	
JS66	ERJ6GEY0R00	M 0 OHM,J,1/10W	1	
JS68	ERJ6GEY0R00	M 0 OHM,J,1/10W	1	
JS70-73	ERJ6GEY0R00	M 0 OHM,J,1/10W	4	
JS76	ERJ6GEY0R00	M 0 OHM,J,1/10W	1	
JS77	ERJ6GEY0R00	M 0 OHM,J,1/10W	1	
JS81	ERJ6GEY0R00	M 0 OHM,J,1/10W	1	
JS83,84	ERJ6GEY0R00	M 0 OHM,J,1/10W	2	
JS87-89	ERJ6GEY0R00	M 0 OHM,J,1/10W	3	
JS93	ERJ6GEY0R00	M 0 OHM,J,1/10W	1	
JS95	ERJ6GEY0R00	M 0 OHM,J,1/10W	1	
JS98	ERJ6GEY0R00	M 0 OHM,J,1/10W	1	
JS100	ERJ6GEY0R00	M 0 OHM,J,1/10W	1	
K5	TJSF20016	16P CONNECTOR	1	
L001	ELESE330JA	PEAKING COIL	1	
L1	TJS3A9880	8P CONNECTOR	1	
L002	ELESE330JA	PEAKING COIL	1	
L2	TJS3A9640	3P CONNECTOR	1	
L003	TALL08N330KA	INDUCTION COIL	1	
L3	TJS3A9680	7P CONNECTOR	1	
L004	TALL08N330KA	INDUCTION COIL	1	
L10	TJSF51701	CONNECTOR	1	
L12	TJSF41601	CONNECTOR	1	
L500	TALL08NR56MA	INDUCTION COIL	1	
L503	TALL13N103JB	INDUCTION COIL	1	
L505	TALFP15B152K	INDUCTION COIL	1	
L506	EXCELSA24	BEAD CHOKE	1	
L508-10	EXCELDLDR25C	BEAD CHOKE	3	
L511	EXCELSA35	BEAD CHOKE	1	
L512	EXCELSA24	BEAD CHOKE	1	
L550	EXCELSA39	BEAD CHOKE	1	
L552	TLHE044	LINEARITY COIL	1	
L554	TLHE045	LINEARITY COIL	1	
L601	TALFP15B152K	INDUCTION COIL	1	
L751	ELC18B121E	CHOKE COIL	1	
△ L801,02	ELF24V050A	LINE FILTER	2	
L811-13	EXCELSA39	BEAD CHOKE	3	
L814	TALL08N101KA	INDUCTION COIL	1	
L815,16	EXCELSA39	BEAD CHOKE	2	
L817,18	EXCELDLDR35C	BEAD CHOKE	2	
L819,20	EXCELSA24	BEAD CHOKE	2	
L821-24	EXCELDLDR35C	BEAD CHOKE	4	
L825	TLUADTB121K	PEAKING COIL	1	
L826	TLUADTB820K	PEAKING COIL	1	
L827	TALL08N470KA	INDUCTION COIL	1	
L828	TALL08N151KA	INDUCTION COIL	1	
L829	EXCELSA35	BEAD CHOKE	1	
L860	TALL08N101KA	INDUCTION COIL	1	
L873	TALL08N330KA	INDUCTION COIL	1	
L876-78	TALFP15B221K	INDUCTION COIL	3	
L879	TAL10RP221LB	INDUCTION COIL	1	

Ref. No	Part No.	Part Name & Description	Pcs.	Remarks
L881	TALL08N101KA	INDUCTION COIL	1	
L904	TLTABT560K	PEAKING COIL	1	
L953	EXCELSA35	BEAD CHOKE	1	
L956	EXCELSA35	BEAD CHOKE	1	
L1102	ELESE4R7JA	PEAKING COIL	1	
L1901	EXCELDLDR35C	BEAD CHOKE	1	
L2303	ELESE330JA	PEAKING COIL	1	
L2306	EXCELSA24	BEAD CHOKE	1	
L3008	TALL08N181KA	INDUCTION COIL	1	
L3050	EXCELDLDR25C	BEAD CHOKE	1	
L3801-03	ELESE100JA	PEAKING COIL	3	
P1	TJS3A9140	CONNECTOR	1	
P2	TJS3A8010	3P CONNECTOR	1	
P3	TJS3A9140	CONNECTOR	1	
P4	TJS3A9680	7P CONNECTOR	1	
Q001	2SD601A	TRANSISTOR	1	
Q022	2SC3311A	TRANSISTOR	1	
Q501	2SK2962	FET	1	
Q502	2SK2847	FET	1	
Q503	2SC3311A	TRANSISTOR	1	
Q509,10	2SC1473	TRANSISTOR	2	
Q551	2SC5612	TRANSISTOR	1	
Q601	2SK1006	FET	1	
Q602	2SK1608	FET	1	
Q603	2SC5460	TRANSISTOR	1	
Q604-06	2SC3311A	TRANSISTOR	3	
Q751	2SK2538	FET	1	
Q802,03	2SC3311A	TRANSISTOR	2	
Q804	2SA1309A	TRANSISTOR	1	
Q805,06	2SC3311A	TRANSISTOR	2	
Q809	2SA1309AR	TRANSISTOR	1	
Q811	2SA1309A	TRANSISTOR	1	
Q854	2SA19610Q0HW	TRANSISTOR	1	
Q902	2SC3311A	TRANSISTOR	1	
Q951	2SA1309A	TRANSISTOR	1	
Q952	2SC3311A	TRANSISTOR	1	
Q955	2SB1569A	TRANSISTOR	1	
Q956	2SD2400A	TRANSISTOR	1	
Q1001,02	2SC3311A	TRANSISTOR	2	
Q1901	2SD601A	TRANSISTOR	1	
Q2301-04	2SD601A	TRANSISTOR	4	
Q3950-52	2SD601A	TRANSISTOR	3	
Q5001	2SD601A	TRANSISTOR	1	
Q5002	2SC3311A	TRANSISTOR	1	
Q5003	2SB709A	TRANSISTOR	1	
Q5004,05	2SD601A	TRANSISTOR	2	
Q5007-14	2SD601A	TRANSISTOR	8	
R001-03	ERJ6GEYJ472	M 4.7KOHM,J,1/10W	3	
R004-06	ERJ6GEY0R00	M 0 OHM,J,1/10W	3	
R007	ERJ6GEYJ121	M 120 OHM,J,1/10W	1	
R008	ERJ6GEYJ331	M 330 OHM,J,1/10W	1	
R010	ERJ6GEYJ152	M 1.5KOHM,J,1/10W	1	
R013,14	ERJ6GEYJ101	M 100 OHM,J,1/10W	2	
R016-19	ERJ6GEYJ220	M 22 OHM,J,1/10W	4	
R025	ERJ6GEYJ472	M 4.7KOHM,J,1/10W	1	
R501	ERDS2TJ104	C 100KOHM, J,1/4W	1	
R502	ERDS2TJ680	C 68 OHM, J,1/4W	1	
R503	ERG3FJS221D	M 220 OHM, J, 3W	1	
R504	ERG1FJS102D	M 1KOHM, J, 1W	1	
R505	ERG1FJS100D	M 10 OHM, J, 1W	1	
R510	ERG2FJ331H	M 330 OHM, J, 2W	1	
R513	ERC12GK103	S 10KOHM, K,1/2W	1	
R514	ER0S2CKF3302	M 33KOHM, F,1/4W	1	
R515	ER0S2CKF2202	M 22KOHM, F,1/4W	1	
R516	ERDS2TJ101	C 100 OHM, J,1/4W	1	
R517	ERDS2TJ103	C 10KOHM, J,1/4W	1	
R518	ERDS1FJ1R5	C 1.5 OHM, J,1/2W	1	
R519	ERQ3CKR39	F0.39 OHM, J, 3W	1	
R520	ERQ14AJ4R7P	F 4.7 OHM, J,1/4W	1	
R521	ER0S2CKF7151	M7.15KOHM, F,1/4W	1	
R522	ER0S2CKF2201	M 2.2KOHM, F,1/4W	1	
R524	EVMEGSA00B14	CONTROL 10KOHMB	1	
R525	ERDS2TJ102	C 1KOHM, J,1/4W	1	
R526	ERQ1CJ560	F 56 OHM, J, 1W	1	
R527	ERDS2TJ222	C 2.2KOHM, J,1/4W	1	
R528	ERQ1CJ120	F 12 OHM, J, 1W	1	
R529	ERDS2TJ183	C 18KOHM, J,1/4W	1	
R530	ERDS2TJ123	C 12KOHM, J,1/4W	1	
R531	ERDS2TJ221	C 220 OHM, J,1/4W	1	
R532,33	ERDS1FJ1R0	C 1 OHM, J,1/2W	2	
R534	ERDS2TJ913	C 91KOHM, J,1/4W	1	
R535	ERDS2TJ562	C 5.6KOHM, J,1/4W	1	

Ref. No	Part No.	Part Name & Description	Pcs.	Remarks
R536	ERDS2TJ101	C 100 OHM, J,1/4W	1	
R537	ERDS2TJ272	C 2.7KOHM, J,1/4W	1	
R538	ERDS2TJ103	C 10KOHM, J,1/4W	1	
R542,43	ERDS2TJ103	C 10KOHM, J,1/4W	2	
R547	ERG1FJS332D	M 3.3KOHM, J, 1W	1	
R548,49	ERG3FJS821D	M 820 OHM, J, 3W	2	
R550	ERDS2TJ622	C 6.2KOHM, J,1/4W	1	
R551-54	ERDS2TJ104	C 100KOHM, J,1/4W	4	
R555	ERDS2TJ102	C 1KOHM, J,1/4W	1	
R556	ERDS2TJ101	C 100 OHM, J,1/4W	1	
R557	ERC14GK334	S 330KOHM, K,1/4W	1	
R558	ERDS2TJ473	C 47KOHM, J,1/4W	1	
R559	ERC12GK104	S 100KOHM, K,1/2W	1	
R560,61	ERDS2TJ125	C 1.2MOHM, J,1/4W	2	
R562	ERDS2TJ153	C 15KOHM, J,1/4W	1	
R563	ERG2FJS123D	M 12KOHM, J, 2W	1	
R564	ERDS2TJ101	C 100 OHM, J,1/4W	1	
R565	ERDS2TJ560	C 56 OHM, J,1/4W	1	
R702,03	ERDS2TJ101	C 100 OHM, J,1/4W	2	
R705	ERDS2TJ103	C 10KOHM, J,1/4W	1	
R706	ERDS2TJ152	C 1.5KOHM, J,1/4W	1	
R709	ERDS1FJ680	C 68 OHM, J,1/2W	1	
R717	ERF5AK4R7	W 4.7 OHM, K, 5W	1	
R718	ERDS2TJ102	C 1KOHM, J,1/4W	1	
R800	ERU5TCK1R5T	F 1.5 OHM, 5W	1	
R801	ERC12UGK105C	S 1MOHM, K,1/2W	1	
R802	ERDS2TJ103	C 10KOHM, J,1/4W	1	
R803	ERDS2TJ153	C 15KOHM, J,1/4W	1	
R804	ERDS2TJ221	C 220 OHM, J,1/4W	1	
R806	ERDS2TJ823	C 82KOHM, J,1/4W	1	
R807	ERDS2TJ151	C 150 OHM, J,1/4W	1	
R808	ERDS1TJ680	C 68 OHM, J,1/2W	1	
R809	ERDS2TJ472	C 4.7KOHM, J,1/4W	1	
R810	ERDS2TJ473	C 47KOHM, J,1/4W	1	
R811	ERDS2TJ472	C 4.7KOHM, J,1/4W	1	
R812	ERDS2TJ473	C 47KOHM, J,1/4W	1	
△ R813	ERD75TAJ825	C 8.2MOHM, J,3/4W	1	
R814	ERG2FJS563D	M 56KOHM, J, 2W	1	
R815	ERDS1FJ681	C 680 OHM, J,1/2W	1	
R816-19	ERX12SJR22P	M 0.22 OHM, J,1/2W	4	
R821,22	ERX12SJ1R0	M 0.1 OHM, J,1/2W	2	
R823	ERDS2TJ472	C 4.7KOHM, J,1/4W	1	
R824	ERDS2TJ332	C 3.3KOHM, J,1/4W	1	
R825	ERDS2TJ182	C 1.8KOHM, J,1/4W	1	
R826	ERDS2TJ222	C 2.2KOHM, J,1/4W	1	
R827	ERDS1FJ3R3	C 3.3 OHM, J,1/2W	1	
R829	ERDS2TJ473	C 47KOHM, J,1/4W	1	
R830	ERDS2TJ103	C 10KOHM, J,1/4W	1	
R831	ERDS2TJ101	C 100 OHM, J,1/4W	1	
R832	ERDS2TJ102	C 1KOHM, J,1/4W	1	
R833	ERDS2TJ183	C 18KOHM, J,1/4W	1	
R834	ERDS2TJ103	C 10KOHM, J,1/4W	1	
R835	ERDS2TJ101	C 100 OHM, J,1/4W	1	
R836	ERDS2TJ102	C 1KOHM, J,1/4W	1	
R837	ERDS2TJ222	C 2.2KOHM, J,1/4W	1	
R838	ERG2FJS820D	M 82 OHM, J, 2W	1	
R839	ERDS2TJ222	C 2.2KOHM, J,1/4W	1	
R840	ERDS2TJ470	C 47 OHM, J,1/4W	1	
R841	ERDS2TJ104	C 100KOHM, J,1/4W	1	
R842	ERDS2TJ223	C 22KOHM, J,1/4W	1	
R843	ERDS2TJ681	C 680 OHM, J,1/4W	1	
R844	ERDS2TJ104	C 100KOHM, J,1/4W	1	
R845	ERDS2TJ332	C 3.3KOHM, J,1/4W	1	
R846	ERDS2TJ473	C 47KOHM, J,1/4W	1	
R847	ERDS2TJ392	C 3.9KOHM, J,1/4W	1	
R850	ERDS1TJ821	C 820 OHM, J,1/2W	1	
R851	ERDS2TJ104	C 100KOHM, J,1/4W	1	
R852	ERDS1FJ182	C 1.8KOHM, J,1/2W	1	
R853,54	ERQ14AJ4R7P	F 4.7 OHM, J,1/4W	2	
R855	ERDS2TJ913	C 91KOHM, J,1/4W	1	
R856	ERDS2TJ123	C 12KOHM, J,1/4W	1	
R857,58	ERDS1FJ1R0	C 1 OHM, J,1/2W	2	
R859	ERDS2TJ272	C 2.7KOHM, J,1/4W	1	
R860	ERDS1FJ102	C 1KOHM, J,1/2W	1	
R865	ERDS2TJ332	C 3.3KOHM, J,1/4W	1	
R890	ERDS2TJ331	C 330 OHM, J,1/4W	1	
R891	ERJ6GEYJ472	M 4.7KOHM, J,1/10W	1	
R892	ERJ6ENF1001	M 1KOHM, 1/10W	1	
R893	ERJ6ENF24R0	M 24 OHM, 1/10W	1	
R894	ERDS1FJ332	C 3.3KOHM, J,1/2W	1	
R897	ERDS2TJ473	C 47KOHM, J,1/4W	1	
R898	ERJ6GEYJ473	M 47KOHM, J,1/10W	1	
R899	ERJ6GEYJ103	M 10KOHM, J,1/10W	1	
R902	ERDS2TJ223	C 22KOHM, J,1/4W	1	
R904	ERDS2TJ101	C 100 OHM, J,1/4W	1	

Ref. No	Part No.	Part Name & Description	Pcs.	Remarks
R905	ERDS2TJ223	C 22KOHM, J,1/4W	1	
R906	ERDS2TJ472	C 4.7KOHM, J,1/4W	1	
R908	ERDS2TJ471	C 470 OHM, J,1/4W	1	
R910,11	ERDS2TJ330	C 33 OHM, J,1/4W	2	
R953	ERDS2TJ470	C 47 OHM, J,1/4W	1	
R954	ERDS2TJ472	C 4.7KOHM, J,1/4W	1	
R955	ERDS2TJ470	C 47 OHM, J,1/4W	1	
R961	ERQ1CJP331S	F 330 OHM, J, 1W	1	
R964	ERDS2FJ391	C 390 OHM, J,1/2W	1	
R965	ERDS2TJ683	C 68KOHM, J,1/4W	1	
R966	ERG3FJS821D	M 820 OHM, J, 3W	1	
R968	ERDS2FJ391	C 390 OHM, J,1/2W	1	
R969-72	ERQ14AJ2R2P	F 2.2 OHM, J,1/4W	4	
R975	ERDS2TJ683	C 68KOHM, J,1/4W	1	
R976,77	ERDS2TJ100	C 10 OHM, J,1/4W	2	
R1050	ERDS2TJ470	C 47 OHM, J,1/4W	1	
R1052	ERDS2TJ102	C 1KOHM, J,1/4W	1	
R1053,54	ERDS2TJ223	C 22KOHM, J,1/4W	2	
R1055	ERDS2TJ272	C 2.7KOHM, J,1/4W	1	
R1056	ER0S2CKF1432	M14.3KOHM, F,1/4W	1	
R1058	ER0S2CKF1741	M1.74KOHM, F,1/4W	1	
R1059	ER0S2CKF1621	M1.62KOHM, F,1/4W	1	
R1060	ER0S2CKF2321	M2.32KOHM, F,1/4W	1	
R1061	ER0S2CKF3161	M3.16KOHM, F,1/4W	1	
R1062	ER0S2CKF6651	M6.65KOHM, F,1/4W	1	
R1063	ERDS2TJ471	C 470 OHM, J,1/4W	1	
R1064	ERDS2TJ562	C 5.6KOHM, J,1/4W	1	
R1065	ERDS2TJ223	C 22KOHM, J,1/4W	1	
R1066	ERDS2TJ273	C 27KOHM, J,1/4W	1	
R1068	ERDS2TJ473	C 47KOHM, J,1/4W	1	
R1069	ERDS2TJ103	C 10KOHM, J,1/4W	1	
R1248	ERDS2TJ682	C 6.8KOHM, J,1/4W	1	
R1249	ERJ6GEYJ184	M 180KOHM, J,1/10W	1	
R1901	ERJ6GEYJ153	M 15KOHM, J,1/10W	1	
R1902	ERJ6GEYJ822	M 8.2KOHM, J,1/10W	1	
R1903	ERJ6GEYJ122	M 1.2KOHM, J,1/10W	1	
R1904	ERJ6GEYJ104	M 100KOHM, J,1/10W	1	
R1905	ERJ6GEYJ222	M 2.2KOHM, J,1/10W	1	
R1906	ERJ6GEYJ472	M 4.7KOHM, J,1/10W	1	
R1908	ERJ6GEY0R00	M 0 OHM, J,1/10W	1	
R1909	ERJ6GEYJ472	M 4.7KOHM, J,1/10W	1	
R1919	ERJ6GEYJ102	M 1KOHM, J,1/10W	1	
R1920	ERJ6GEYJ152	M 1.5KOHM, J,1/10W	1	
R1921	ERJ6GEYJ392	M 3.9KOHM, J,1/10W	1	
R1923	ERJ6GEYJ473	M 47KOHM, J,1/10W	1	
R2301	ERDS2TJ122	C 1.2KOHM, J,1/4W	1	
R2302,03	ERJ6GEYJ222	M 2.2KOHM, J,1/10W	2	
R2304	ERQ12HKR22	F 0.22 OHM, J,1/2W	1	
R2305	ERDS2TJ822	C 8.2KOHM, J,1/4W	1	
R2309-11	ERDS1FJ2R2	C 2.2 OHM, J,1/2W	3	
R2312,13	ERJ6GEYJ182	M 1.8KOHM, J,1/10W	2	
R2314	ERJ6GEYJ392	M 3.9KOHM, J,1/10W	1	
R2316	ERJ6GEYJ103	M 10KOHM, J,1/10W	1	
R2318-20	ERJ6GEYJ101	M 100 OHM, J,1/10W	3	
R2321,22	ERJ6GEYJ222	M 2.2KOHM, J,1/10W	2	
R2333,34	ERJ6GEYJ183	M 18KOHM, J,1/10W	2	
R2335	ERJ6GEYJ224	M 220KOHM, J,1/10W	1	
R2336	ERJ6GEYJ154	M 150KOHM, J,1/10W	1	
R2337	ERJ6GEYJ151	M 150 OHM, J,1/10W	1	
R2338	ERJ6GEYJ224	M 220KOHM, J,1/10W	1	
R2339,40	ERJ6GEYJ822	M 8.2KOHM, J,1/10W	2	
R2371,72	ERDS1TJ121	C 120 OHM, J,1/2W	2	
R2373,74	ERDS1TJ561	C 560 OHM, J,1/2W	2	
R2376	ERDS1TJ561	C 560 OHM, J,1/2W	1	
R2381,82	ERDS1TJ560	C 56 OHM, J,1/2W	2	
R2385,86	ERJ6GEYJ151	M 150 OHM, J,1/10W	2	
R2387	ERJ6GEYJ101	M 100 OHM, J,1/10W	1	
R2388	ERJ6GEYJ103	M 10KOHM, J,1/10W	1	
R2389,90	ERJ6GEYJ473	M 47KOHM, J,1/10W	2	
R2393,94	ERJ6GEYJ562	M 5.6KOHM, J,1/10W	2	
R2443	ERJ6GEYJ151	M 150 OHM, J,1/10W	1	
R2444	ERJ6GEY0R00	M 0 OHM, J,1/10W	1	
R2445	ERJ6GEYJ154	M 150KOHM, J,1/10W	1	
R2448	ERJ6GEYJ473	M 47KOHM, J,1/10W	1	
R2449,50	ERJ6GEYJ103	M 10KOHM, J,1/10W	2	
R2452	ERJ6GEYJ103	M 10KOHM, J,1/10W	1	
R2453,54	ERJ6GEYJ822	M 8.2KOHM, J,1/10W	2	
R2455	ERJ6ENF2202	M 2.2KOHM, 1/10W	1	
R2456,57	ERJ6GEYJ101	M 100 OHM, J,1/10W	2	
R2458	ERJ6ENF1502	M 15KOHM, 1/10W	1	
R2461	ERJ6GEYJ104	M 100KOHM, J,1/10W	1	
R2462	ERJ6GEYJ103	M 10KOHM, J,1/10W	1	
R2463	ERJ6GEYJ224	M 220KOHM, J,1/10W	1	
R2464	ERJ6GEYJ472	M 4.7KOHM, J,1/10W	1	
R2465	ERJ6GEYJ103	M 10KOHM, J,1/10W	1	

Ref. No	Part No.	Part Name & Description	Pcs.	Remarks
R2466	ERJ6GEYJ104	M 100KOHM,J,1/10W	1	
R2467,68	ERJ6GEY0R00	M 0 OHM,J,1/10W	2	
R2469	ERJ6GEYJ102	M 1KOHM,J,1/10W	1	
R2470	ERJ6GEYJ183	M 18KOHM,J,1/10W	1	
R2471	ERJ6GEYJ102	M 1KOHM,J,1/10W	1	
R2472	ERJ6GEYJ103	M 10KOHM,J,1/10W	1	
R2475,76	ERJ6GEY0R00	M 0 OHM,J,1/10W	2	
R2477	ERJ6GEYJ183	M 18KOHM,J,1/10W	1	
R2479,80	ERJ6GEYJ223	M 22KOHM,J,1/10W	2	
R2481,82	ERJ6GEYJ273	M 27KOHM,J,1/10W	2	
R2487,88	ERJ6GEYJ562	M 5.6KOHM,J,1/10W	2	
R2489,90	ERJ6GEYJ103	M 10KOHM,J,1/10W	2	
R2491,92	ERJ6GEYJ183	M 18KOHM,J,1/10W	2	
R2493,94	ERJ6GEYJ822	M 8.2KOHM,J,1/10W	2	
R2495,96	ERJ6GEYJ123	M 12KOHM,J,1/10W	2	
R2497,98	ERJ6GEYJ822	M 8.2KOHM,J,1/10W	2	
R2499	ERJ6GEYJ103	M 10KOHM,J,1/10W	1	
R3801	ER0S2CKF1001	M 1KOHM, F,1/4W	1	
R3802	ERDS2TJ122	C 1.2KOHM, J,1/4W	1	
R3803	ERG3SJ393H	M 39KOHM, J, 3W	1	
R3805	ERDS2TJ822	C 8.2KOHM, J,1/4W	1	
R3808	ERDS2TJ332	C 3.3KOHM, J,1/4W	1	
R3809	ERC12GK471	S 470 OHM, K,1/2W	1	
R3811	ER0S2CKF1001	M 1KOHM, F,1/4W	1	
R3812	ERDS2TJ122	C 1.2KOHM, J,1/4W	1	
R3813	ERG3SJ393H	M 39KOHM, J, 3W	1	
R3815	ERDS2TJ562	C 5.6KOHM, J,1/4W	1	
R3818	ERDS2TJ102	C 1KOHM, J,1/4W	1	
R3819	ERC12GK471	S 470 OHM, K,1/2W	1	
R3821	ER0S2CKF1001	M 1KOHM, F,1/4W	1	
R3822	ERDS2TJ122	C 1.2KOHM, J,1/4W	1	
R3823	ERG3SJ393H	M 39KOHM, J, 3W	1	
R3825	ERDS2TJ822	C 8.2KOHM, J,1/4W	1	
R3828	ERDS2TJ122	C 1.2KOHM, J,1/4W	1	
R3829	ERC12GK471	S 470 OHM, K,1/2W	1	
R3830	ER0S2CKF2702	M 27KOHM, F,1/4W	1	
R3831	ER0S2CKF1372	M13.7KOHM, F,1/4W	1	
R3837	ERDS2TJ103	C 10KOHM, J,1/4W	1	
R3838	ERDS2TJ563	C 56KOHM, J,1/4W	1	
R5001,02	ERJ6GEYJ220	M 22 OHM,J,1/10W	2	
R5003,04	ERJ6GEY0R00	M 0 OHM,J,1/10W	2	
R5005	ERJ6GEYJ102	M 1KOHM,J,1/10W	1	
R5006	ERJ6GEYJ222	M 2.2KOHM,J,1/10W	1	
R5007	ERJ6GEYJ102	M 1KOHM,J,1/10W	1	
R5008	ERJ6GEYJ222	M 2.2KOHM,J,1/10W	1	
R5009	ERJ6GEYJ223	M 22KOHM,J,1/10W	1	
R5010	ERJ6GEYJ102	M 1KOHM,J,1/10W	1	
R5011	ERJ6GEYJ223	M 22KOHM,J,1/10W	1	
R5012,13	ERJ6GEYJ220	M 22 OHM,J,1/10W	2	
R5018,19	ERJ6GEYJ220	M 22 OHM,J,1/10W	2	
R5020	ERJ6GEYJ223	M 22KOHM,J,1/10W	1	
R5021-24	ERJ6GEYJ103	M 10KOHM,J,1/10W	4	
R5025	ERJ6GEYJ220	M 22 OHM,J,1/10W	1	
R5027	ERJ6GEYJ220	M 22 OHM,J,1/10W	1	
R5030	ERJ6GEYJ103	M 10KOHM,J,1/10W	1	
R5031	ERJ6GEYJ822	M 8.2KOHM,J,1/10W	1	
R5032,33	ERJ6GEYJ220	M 22 OHM,J,1/10W	2	
R5034	ERJ6GEYJ104	M 100KOHM,J,1/10W	1	
R5035	ERDS2TJ471	C 470 OHM, J,1/4W	1	
R5036	ERJ6GEYJ223	M 22KOHM,J,1/10W	1	
R5037	ERJ6GEYJ104	M 100KOHM,J,1/10W	1	
R5038	ERJ6GEYJ473	M 47KOHM, J,1/10W	1	
R5039	ERJ6GEYJ103	M 10KOHM,J,1/10W	1	
R5040	ERJ6GEYJ223	M 22KOHM,J,1/10W	1	
R5041	ERJ6GEYJ103	M 10KOHM,J,1/10W	1	
R5042	ERJ6GEYJ223	M 22KOHM,J,1/10W	1	
R5043-45	ERJ6GEYJ103	M 10KOHM,J,1/10W	3	
R5046	ERJ6GEYJ822	M 8.2KOHM,J,1/10W	1	
R5048	ERJ6GEYJ472	M 4.7KOHM,J,1/10W	1	
R5049	ERJ6GEYJ622	M 6.2KOHM,J,1/10W	1	
R5050	ERJ6GEYJ272	M 2.7KOHM,J,1/10W	1	
R5051	ERJ6GEYJ223	M 22KOHM,J,1/10W	1	
R5052,53	ERJ6GEYJ220	M 22 OHM,J,1/10W	2	
R5054,55	ERJ6GEYJ242	M 2.4KOHM,J,1/10W	2	
R5063	ERJ6GEYJ473	M 47KOHM,J,1/10W	1	
R5068	ERJ6GEY0R00	M 0 OHM,J,1/10W	1	
R5069	ERJ6GEYJ102	M 1KOHM,J,1/10W	1	
R5070	ERJ6GEYJ473	M 47KOHM,J,1/10W	1	
R5073	ERJ6GEYJ103	M 10KOHM,J,1/10W	1	
R5075	ERJ6GEYJ472	M 4.7KOHM,J,1/10W	1	
R5076	ERJ6GEYJ473	M 47KOHM,J,1/10W	1	
R5077	ERJ6GEYJ103	M 10KOHM,J,1/10W	1	
R5078	ERJ6GEYJ102	M 1KOHM,J,1/10W	1	
R6800	ERDS2TJ183	C 18KOHM, J,1/4W	1	
R6801	ERDS1TJ680	C 68 OHM, J,1/2W	1	

Ref. No	Part No.	Part Name & Description	Pcs.	Remarks
R6802	ERDS2TJ561	C 560 OHM, J,1/4W	1	
△	RL001	TSEH8011	RELAY	1
△	RL002	TSEH0032	RELAY	1
△	RL010	TSEH0013	RELAY	1
	RL803	TSEH0013	RELAY	1
	RL5001	TSEH8017	RELAY	1
RM001	PNA4601M04TV	REMOTE CONTROL RECIEVER1		
	RT1	TJS3A9640	3P CONNECTOR	1
S002-08	EVQ23405R	SWITCH	7	
	S801	TSED0012	SWITCH	1
	T001	ETP28Z449BY	REMOCON TRANS	1
	T501	ETH19K186AM	REMOCON TRANS	1
△	T551	ZTFM77002A1	FLYBACK TRANS	1
	T552	ETF18L101A	TRANS	1
△	T801	ETS45FA1F5NC	SWITCHING TRANS	1
△	TNR001	ENGD6101D	TUNER	1
△	TNR003	ENG36601G	TUNER	1
Serviceable Boards				
△	RTL	TZTNP010ERR	CIRCUIT BOARD D	1
△	RTL	TNPA1531AB	CIRCUIT BOARD G	1
△	RTL	TNPA1532	CIRCUIT BOARD K	1
△	RTL	TNPA1536AB	CIRCUIT BOARD L	1
△	RTL	TNPA1675	CIRCUIT BOARD P	1
△	RTL	TNPH0340	CIRCUIT BOARD A	1
Non-Serviceable Boards				
△	RTL	TNAG076	CIRCUIT BOARD DG	1
△	RTL	TNAG063	CIRCUIT BOARD U	1
△	RTL	TNPA1520AC	CIRCUIT BOARD DD	1
△	RTL	TNPA1523AF	CIRCUIT BOARD Q	1
△	RTL	TNPA1524AC	CIRCUIT BOARD AG	1
△	RTL	TNPA1676	CIRCUIT BOARD CC	1
△	RTL	TNPA1710	CIRCUIT BOARD H	1