

Service Manual

**CIRCUIT & MECHANISM
DESCRIPTIONS
REPAIR & ADJUSTMENTS**



**ORDER NO.
ARP 1084-0**

STEREO TURNTABLE

PL-X55Z[BK] PL-X55Z

MODEL PL-X55Z COMES IN THREE VERSIONS DISTINGUISHED AS FOLLOWS:

Type	Applicable model		Power requirement	Destination
	PL-X55Z (BK)	PL-X55Z		
ZE	—	○	(DC power supply)	European continent
Z/G	○	—	(DC power supply)	U.S. Military
ZUEM	○	—	(DC power supply)	U.S.A. Australia European continent and West Germany

- This service manual is applicable to the Z/G, ZUEM and Z/E types.
- As to the PL-X55Z(BK)/Z/G and PL-X55Z/Z/E types, please refer to page 25.
- PL-X55Z (BK) is the same as the PL-X55Z except for the exterior design (color). (PL-X55Z comes in silver; PL-X55Z (BK) is black)
- Ce manuel d'instruction se réfère au mode de réglage en français.
- Este manual de servicio trata del método de ajuste escrito en español.

CONTENTS

1. SPECIFICATIONS	2	8. SCHEMATIC DIAGRAM	9
2. PANEL FACILITIES	2	9. EXPLODED VIEWS	10
3. PACKING	3	10. PRECAUTIONS FOR REASSEMBLY	15
4. DISASSEMBLY	4	11. ADJUSTMENTS	19
5. PARTS LOCATION	6	RÉGLAGE	21
6. ELECTRICAL PARTS LIST	7	AJUSTE	23
7. P.C. BOARDS CONNECTION DIAGRAM	8	12. FOR Z/G, AND ZE TYPES	25

1. SPECIFICATIONS

Motor, Platter

Motor Type	DC servo motor
Drive Method	belt drive
Speed	33.3, 45 RPM
Speed Variation	0.05% WRMS (JIS) ± 0.07% WTD Peak (DIN)
S/N Ratio	68 dB (DIN-B)
Platter	304 mm dia., die-cast aluminum

Tonearm

Type	static-balance type, straight tonearm
------------	---------------------------------------

Installed Cartridge (PC-295T)

Type	MM type
Replacement Stylus	PN-295T
Stylus	0.6 mil diamond
Output voltage	2.5 mV (1 kHz, 5 cm/s, Lat. peak)
Tracking Force	1 – 1.5 g (optimum 1.25 g)
Frequency Response	10 Hz to 30,000 Hz
Load Resistance	50 kΩ
Cartridge Weight	6 g

Other

Dimensions	360 W x 96.5 H x 384 D (mm)
	14-3/16(W) x 3-13/16(H) x 15-1/16(D) in

Weight

PL-X55Z	3.2 kg (7 lb 1 oz)
PL-X33Z	3.1 kg (6 lb 14 oz)

Accessories

45-RPM Adaptor	1
Screws	4

SYSTEM ACCESSORIES

Operating Instructions	1
------------------------------	---

Specifications and design subject to possible modifications without notice due to improvement.

2. PANEL FACILITIES

TURNTABLE

The illustration shows model [PL-X55Z]

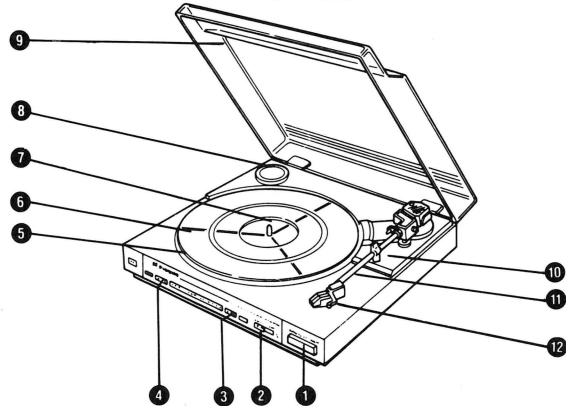

1 START/STOP switch (Only PL-X55Z)

Press this switch when starting auto play or when stopping play.

NOTE:

Be sure to press the switch firmly when starting playback; if not pressed firmly, the platter may rotate without the tonearm moving.

2 CUT switch (Only PL-X33Z)

Press this switch when stopping play.

3 DISC SIZE switch (Only PL-X55Z)

- Use the switch for manual play.
 - Use the switch to suspend record play temporarily.
 - Use the switch when changing the tracks during actual play.
- [UP]: The tonearm rises (the stylus moves away from the record).
 [DOWN]: The tonearm descends (the stylus is lowered onto the record).

4 SPEED switch

- Set this switch in accordance with the size of the record.
 30 (■): For 30 cm LP records. 17 (■): for 17cm EP records.
- Set this switch in accordance with the speed of the record.
 33 (■): For 33-1/3 rpm records. 45 (■): For 45 rpm records.

5 Platter

6 Rubber mat

7 Platter shaft

8 EP adaptor

9 Dust cover

10 Arm rest

11 Tonearm

12 Cartridge

NOTE:

PL-X33Z is not equipped with switch 3.

3. PACKING

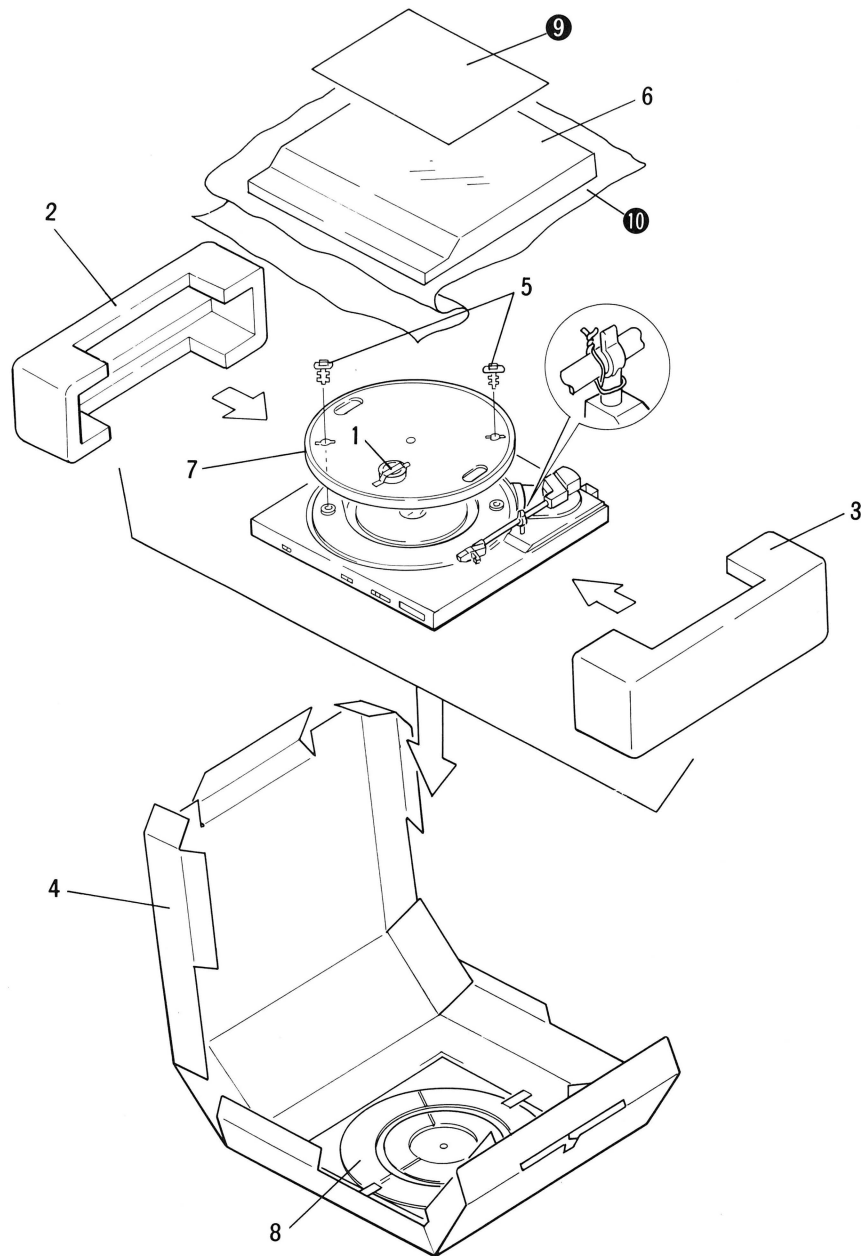

Parts List of Packing

Mark	No.	Part No.	Description
	1.	N93-603	45 adaptor
	2.	PHA-212	Protector (L)
	3.	PHA-213	Protector (R)
	4.	PHH-335	Packing case
	5.	PNY-479	Clamper
	6.	PNV-063	Dust cover
	7.	PNR-232	Turntable platter
	8.	PEA-080	Turntable sheet assembly
	9.		Caution card
	10.		Mirror mat

- **Mechanism Assembly (Sub-panel Assembly) and Motor**

1. Rotate the turntable platter to disengage the mechanism.
2. Fix the tonearm to the arm rest. (Be sure to cover the stylus with the stylus cover.)
3. Remove the turntable sheet assembly and then the turntable platter.
4. Close the dust cover, turn the turntable upside down, and place it on a soft surface, e.g., a work bench covered with soft cloth (for product protection).
5. Remove the five screws labeled ❶, and remove the under base.
6. Remove the five screws labeled ❷ and one screw labeled ❸, and remove the lead connected to the microswitch. This operation will release the mechanism assembly.
7. Remove the two screws labeled ❹ to remove the motor assembly.

- **Tonearm assembly**

1. Remove the mechanism assembly from the panel.
2. Unsolder and disconnect the PU leads (arm leads) from the PU printed circuit board.
3. Remove the AS spring from the PU plate assembly.
4. Remove the screw labeled ❺, and remove the PU plate assembly from the tonearm assembly.
5. Remove the R clip.
6. Place the turntable on one of its sides, remove the arm clamp, and gently pull out the tonearm assembly from the panel.

5. PARTS LOCATION

NOTES:

- The \triangle mark found on some component parts indicates the importance of the safety factor of the part. Therefore, when replacing, be sure to use parts of identical designation.
- For your parts Stock Control, the fast moving items are indicated with the marks $\star\star$ and \star .
 $\star\star$ **GENERALLY MOVES FASTER THAN \star**
 This classification shall be adjusted by each distributor because it depends on model number, temperature, humidity, etc.
- Parts marked by “ \odot ” are not always kept in stock. Their delivery time may be longer than usual or they may be unavailable.

Front View

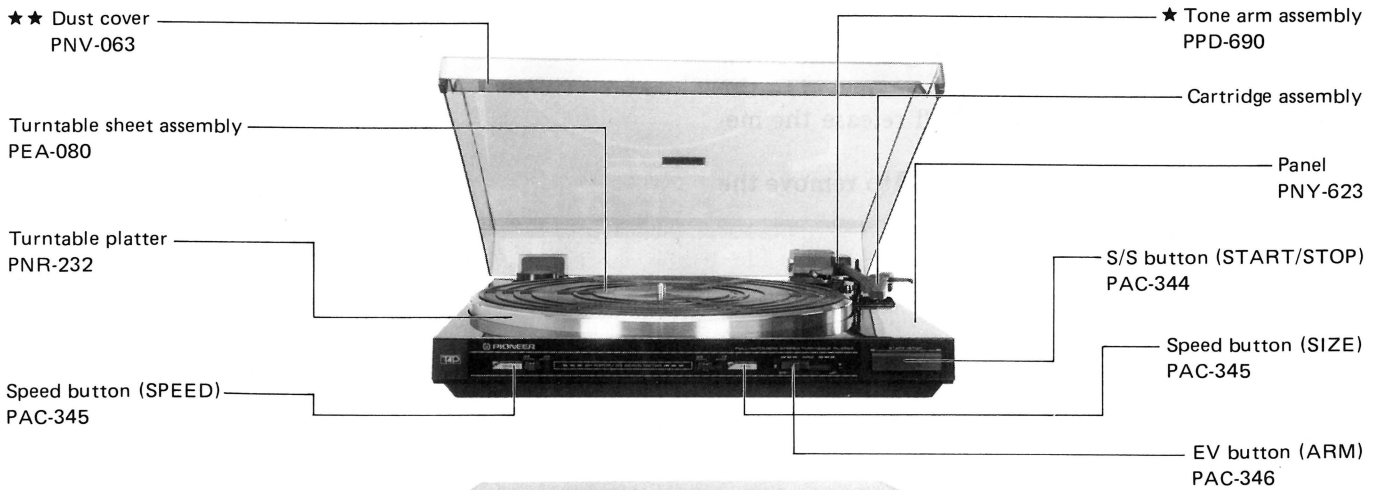

Rear View

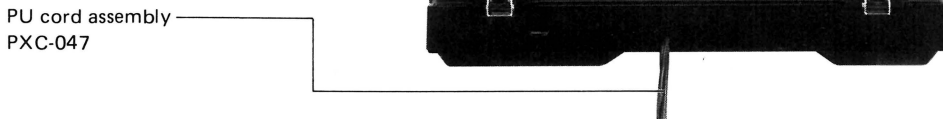

Inside View with Bottom Plate Removed

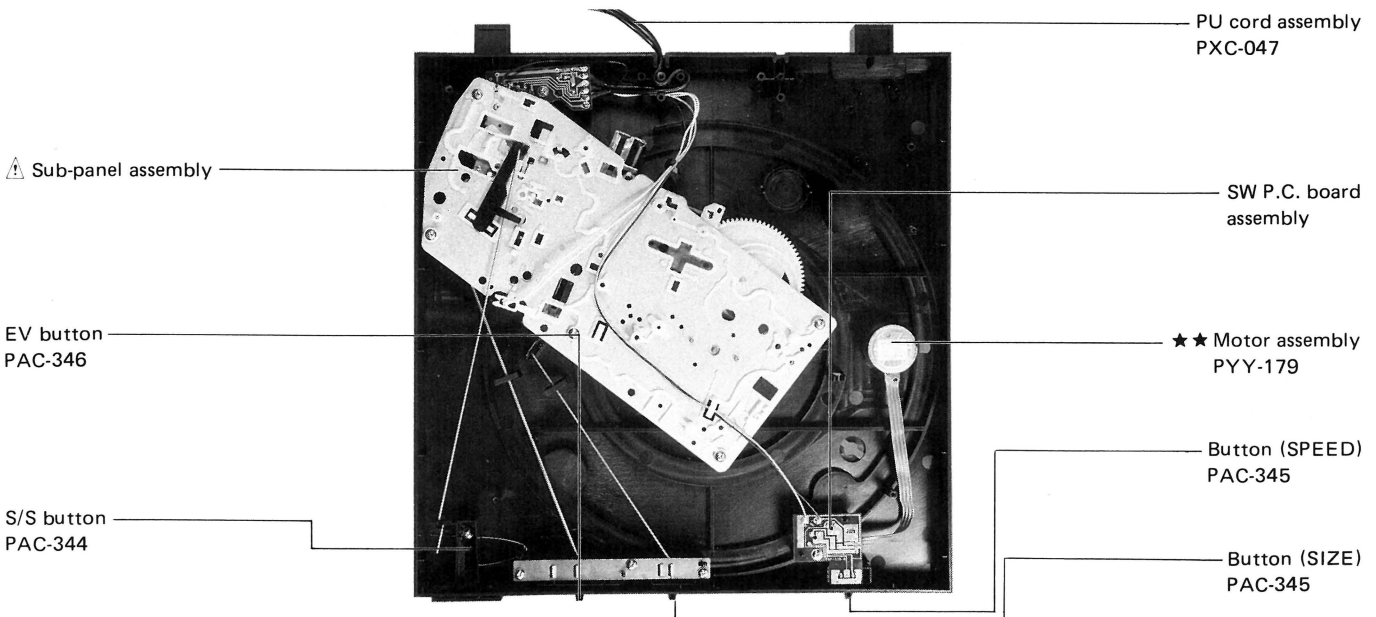

Mechanism View (Sub-panel Assembly)

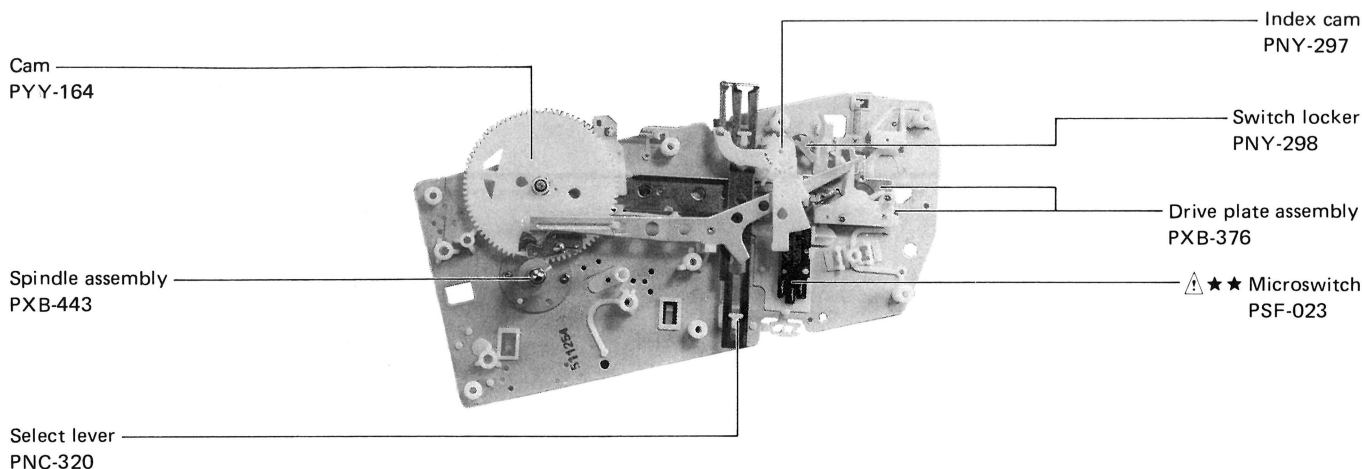

6. ELECTRICAL PARTS LIST

NOTES:

- When ordering resistors, first convert resistance values into code form as shown in the following examples.
 - Ex. 1 When there are 2 effective digits (any digit apart from 0), such as 560 ohm and 47k ohm (tolerance is shown by J = 5%, and K = 10%).

560Ω	56 × 10 ¹	561.....	RD1/4PS	□	□	□	J
47kΩ	47 × 10 ³	473.....	RD1/4PS	□	□	□	J
0.5Ω	0R5.....		RN2H	□	□	□	K
1Ω	010.....		RS1P	□	□	□	K
 - Ex. 2 When there are 3 effective digits (such as in high precision metal film resistors).

5.62kΩ	562 × 10 ¹	RN1/4SR	□	□	□	□	F
--------	-----------------------	-------	---------	---	---	---	---	---
- The Δ mark found on some component parts indicates the importance of the safety factor of the part. Therefore, when replacing, be sure to use parts of identical designation.
- For your parts Stock Control, the fast moving items are indicated with the marks $\star\star$ and \star .
 - $\star\star$ GENERALLY MOVES FASTER THAN \star
 - This classification shall be adjusted by each distributor because it depends on model number, temperature, humidity, etc.
- Parts marked by “ \odot ” are not always kept in stock. Their delivery time may be longer than usual or they may be unavailable.

Miscellaneous Parts

Mark	Symbol & Description	Part No.
	SW P.C. Board assembly	non supply
	PU cord assembly	PXC-047
$\star\star$	Motor assembly	PYY-179
$\star\star$	S1 Microswitch (POWER)	PSF-023

PU Cord Assembly (PXC-047)

CAPACITOR

Mark	Symbol & Description	Part No.
	C1	CKDYF103Z50

SW. P.C. Board Assembly

SWITCH

Mark	Symbol & Description	Part No.
$\star\star$	S2 Slide switch (SPEED)	PSH-018

CAPACITOR

Mark	Symbol & Description	Part No.
	C2	CEA220M16

RESISTORS

Mark	Symbol & Description	Part No.
\star	VR1 Semi-fixed (10KΩ)	VRTG6VS103
\star	VR2 Semi-fixed (22KΩ)	VRTG6VS223
	R1, R2	RD1/6PM□□□J

7. P.C. BOARDS CONNECTION DIAGRAM

A

A

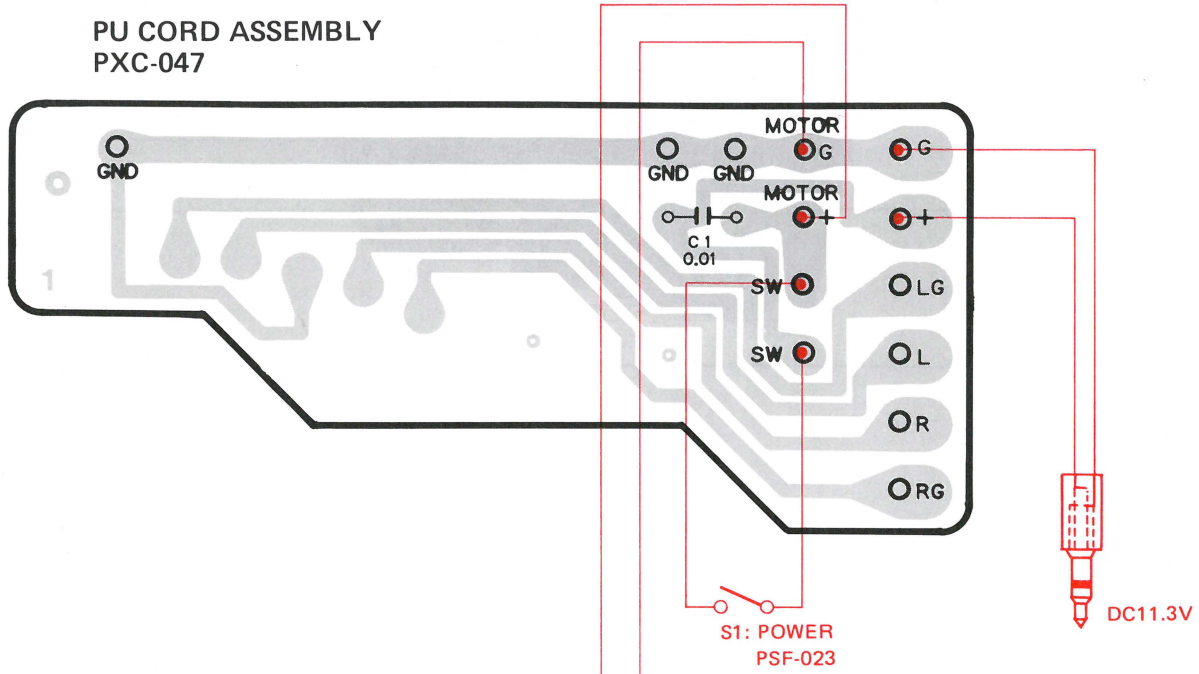

B

B

C

C

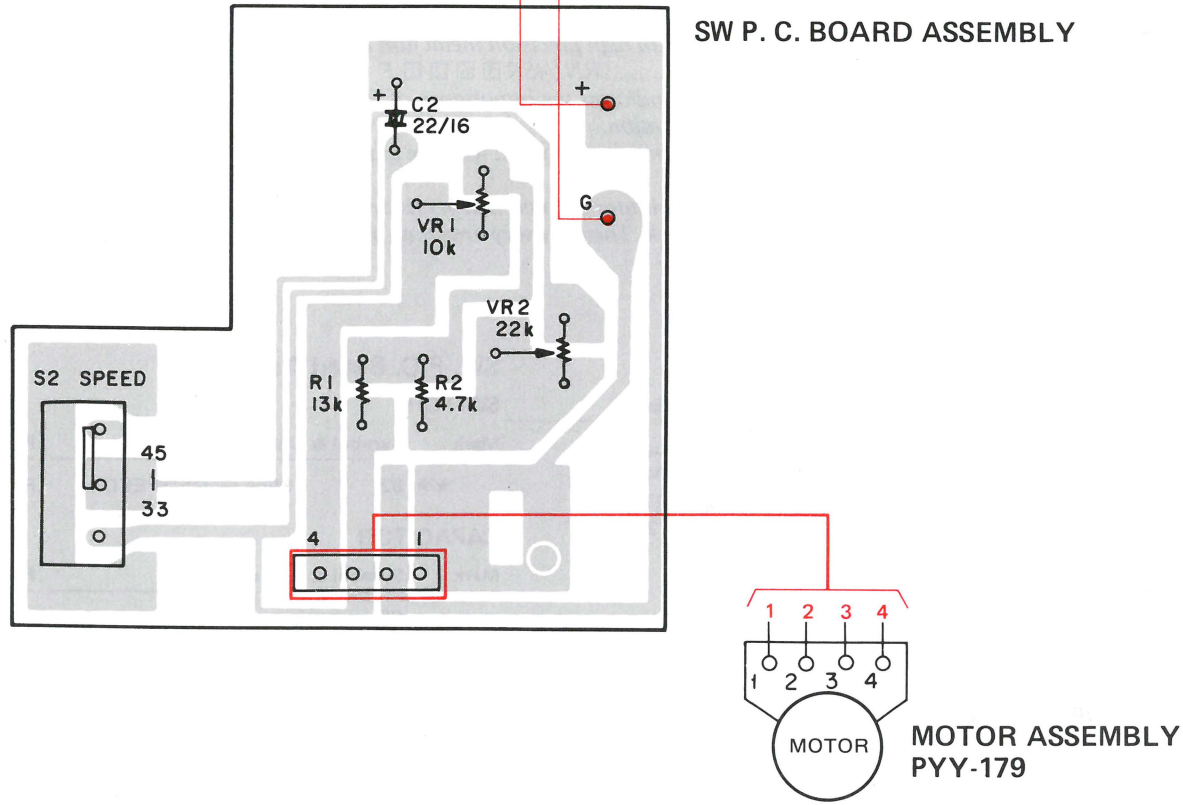

D

D

8. SCHEMATIC DIAGRAM

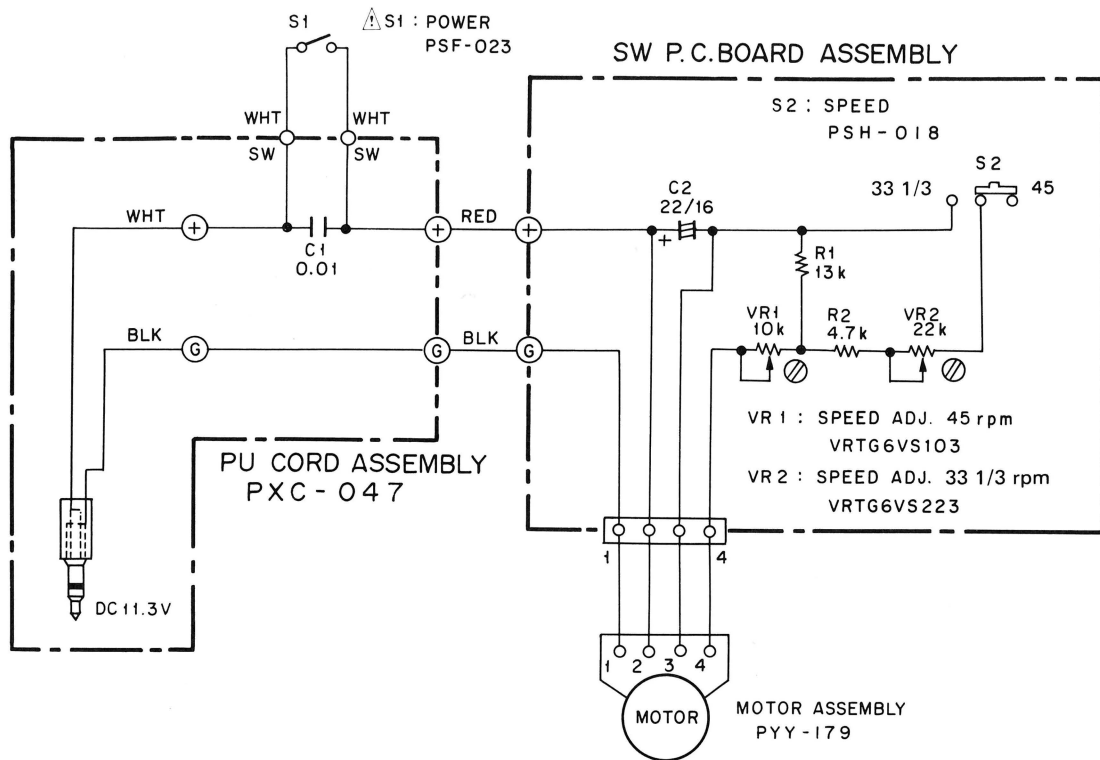

1. RESISTORS:

Indicated in Ω , 1/6 W $\pm 5\%$ tolerance unless otherwise noted k : k Ω , M : M Ω , (F) : $\pm 1\%$, (G) : $\pm 2\%$, (K) : $\pm 10\%$ (M); $\pm 20\%$ tolerance

2. CAPACITORS:

Indicated in capacity (μF)/voltage (V) unless otherwise noted p : pF Indication without voltage is 50V except electrolytic capacitor.

3. VOLTAGE :

: DC voltage (V) at no input signal

4. OTHERS:

: Signal route.

: Adjusting point.

The mark found on some component parts indicates the importance of the safety factor of the part. Therefore, when replacing, be sure to use parts of identical designation.

* marked capacitors and resistors have parts numbers.

This is the basic schematic diagram, but the actual circuit may vary due to improvements in design.

SWITCHES:

S1 : POWER ON - OFF

S2 : SPEED 33 1/3rpm - 45rpm

The underlined indicates the switch position.

9. EXPLODED VIEWS

9.1 EXTERIOR

NOTES:

- Parts without part number cannot be supplied.
- The \triangle mark found on some component parts indicates the importance of the safety factor of the part. Therefore, when replacing, be sure to use parts of identical designation.
- For your parts Stock Control, the fast moving items are indicated with the marks $\star\star$ and \star .
 $\star\star$ GENERALLY MOVES FASTER THAN \star
 This classification shall be adjusted by each distributor because it depends on model number, temperature, humidity, etc.
- Parts marked by “ \odot ” are not always kept in stock. Their delivery time may be longer than usual or they may be unavailable.

Parts List of Exterior

Mark	No.	Part No.	Description	Mark	No.	Part No.	Description
	1.	PXC-047	PU cord assembly		36.	IPC30P100FMC	Screw
	2.	CKDYF103Z50	Ceramic capacitor (C1)		37.	IPC30P100FMC	Screw
	3.	N93-603	45 adaptor		38.	PEB-277	Insulator
	4.	PBA-170	Cartridge mounting screw		39.	WA40F140M100	Washer
\star	5.	PPD-690	Tone arm assembly		40.	BPZ26P120FZK	Screw
	6.	PEA-080	Turntable sheet assembly		41.	PAM-206	Front panel name
$\star\star$	7.	PEB-296	Belt		42.	PNY-623	Panel
	8.	PNR-232	Turntable platter		43.	PAC-344	S/S button (START/STOP)
	9.	PBA-112	Motor mounting screw		44.	PAC-345	Speed button (SPEED, SIZE)
	10.	PEB-172	Rubber		45.	PAC-346	EV button (ARM)
	11.	PBH-470	AS spring		46.	PAM-207	AS name plate
	12.	PBK-059	R clip		47.	PXV-973	Cartridge (Without stylus)
\star	13.	PNY-345	Arm rest	$\star\star$	48.	PYY-179	Motor assembly
	14.	PBF-020	Poly slider washer				
	15.	PBH-462	EV spring		101.		SW P.C. board assembly
				\triangle	102.		Sub panel assembly
	16.	PNY-578	EV sheet		103.		PU plate spring
	17.	IPC30P100FMC	Screw		104.		Screw
	18.	PBH-463	EV lever spring		105.		PU spring washer
	19.	PBH-464	Elevation cam spring		106.		PU plate (A)
	20.	PNY-576	Elevation cam		107.		PU plate (B)
	21.	PXV-092	EV plate spring (D) unit		108.		S/S rod
	22.	WT31D054D050	Washer		109.		Size rod
	23.	PXB-428	PU plate assembly		110.		EV rod
	24.	WC40FMC	Washer		111.		Start lever
	25.	YS40FBT	Washer		112.		Rubber
	26.	IPC30P100FMC	Screw		113.		Under base
	27.	IPC30P100FMC	Screw		114.		Pivot lock nut
	28.	IPC30P100FMC	Screw		115.		Pivot
	29.	IPC30P100FMC	Screw		116.		Weight
	30.	IPC30P290FMC	Screw		117.		Pivot screw
	31.	PBH-409	S/S spring		118.		Cartridge assembly
	32.	PBK-100	EV angle		119.		Ground lug unit
	33.	PSZ30P060FMC	Screw		120.		Centerholder assembly
$\star\star$	34.	PNV-063	Dust cover				
\star	35.	PXC-066	Hinge assembly				

Exterior

1

2

3

4

5

A

B

C

D

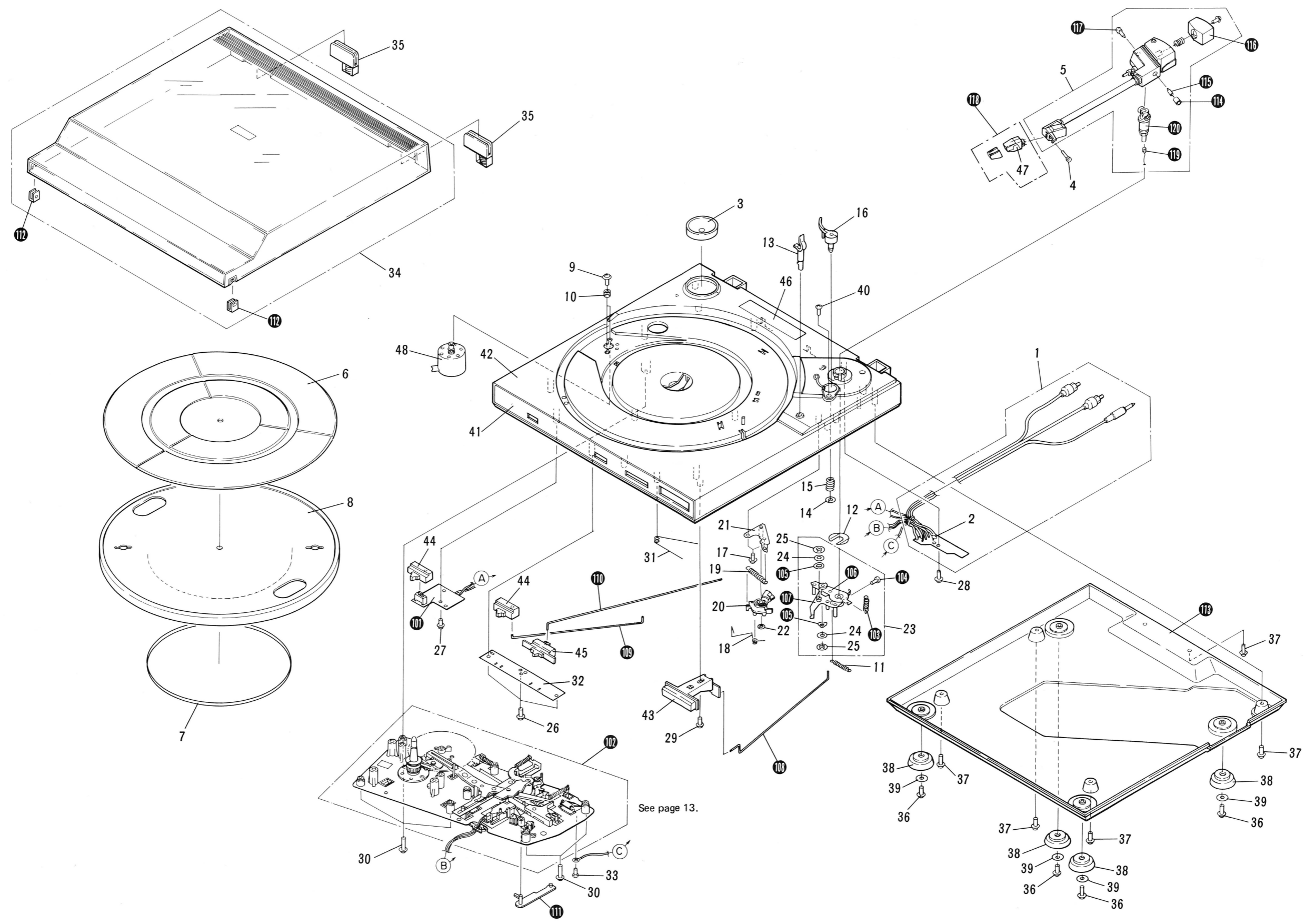

A

B

C

D

1

2

3

4

5

6

9.2 SUB-PANEL ASSEMBLY

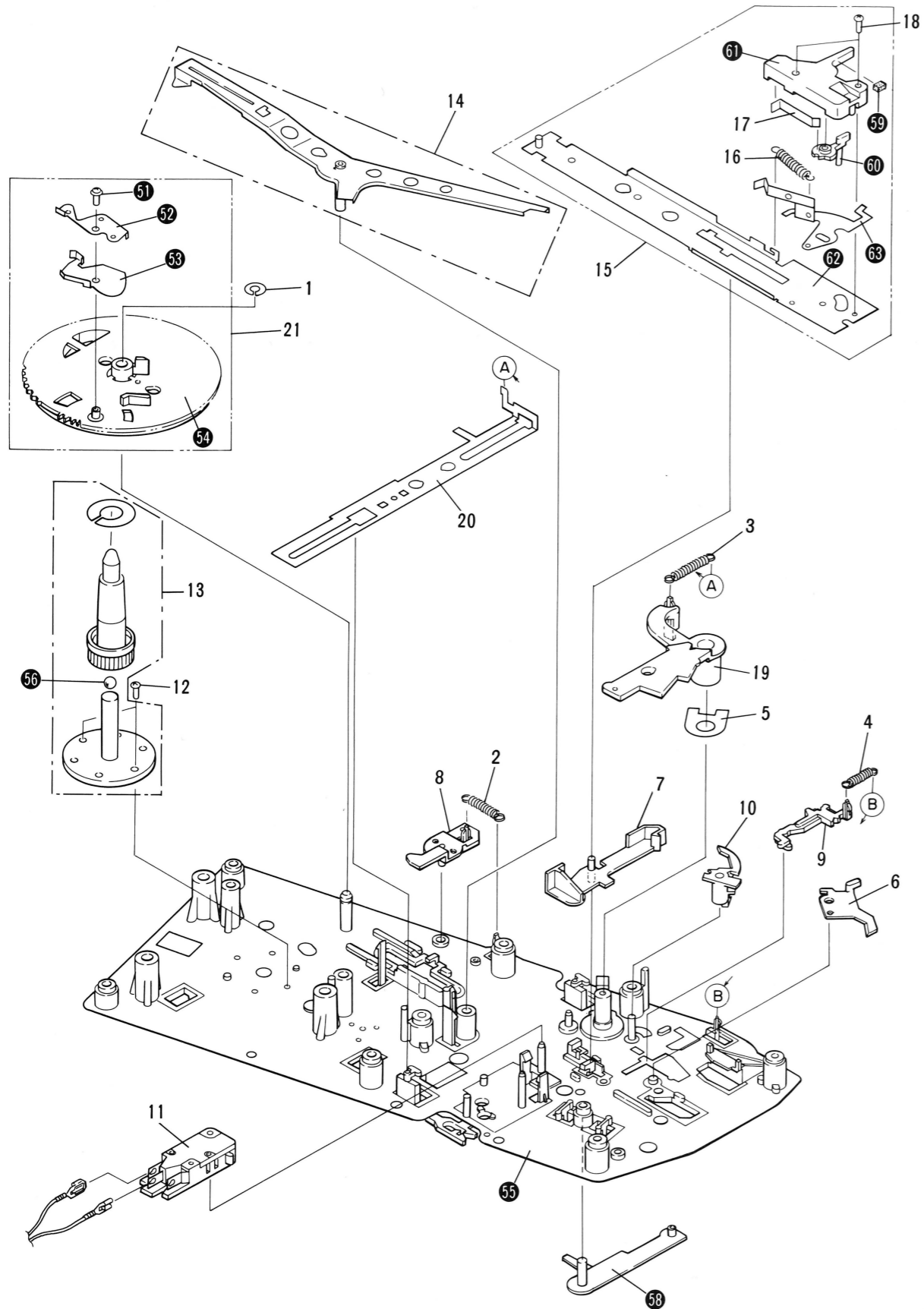

Parts List of Sub-panel

Mark	No.	Part No.	Description	Mark	No.	Part No.	Description
	1.	PBF-018	Washer		51.		Screw
	2.	PBH-392	Lock plate spring		52.		Signal plate
	3.	PBH-393	Select lever spring		53.		Automatic plate
	4.	PBH-394	Reset plate spring				
	5.	PBK-039	Spring washer		54.		Cam
	6.	PNX-028	Reset plate		55.		Sub-panel base
	7.	PNX-030	Switch lever		56.		Steel ball
	8.	PNY-139	Lock plate		57.	
	9.	PNY-140	Selector		58.		Start lever
	10.	PNY-298	Switch locker		59.		EV cam buffer
					60.		Read in Latch
	★ ★ 11.	PSF-023	Microswitch (POWER, S1)		61.		EV cam
	12.	PSZ30P080FMC	Screw		62.		Drive plate unit
	13.	PXB-443	Spindle assembly		63.		Start plate unit
	14.	PXT-446	Detect lever unit				
	15.	PXB-376	Drive plate assembly				
	16.	PBH-224	Start plate spring				
	17.	PBK-038	Click plate spring				
	18.	PMZ26P100FMC	Screw				
	19.	PNY-297	Index cam				
	20.	PNC-320	Select lever				
	21.	PYY-164	Cam assembly				

10. PRECAUTIONS FOR REASSEMBLY

If new parts have been used, follow these directions and precautions when reassembling a unit after completing repairs. Be sure to lubricate as required, make no mistakes when attaching parts, and avoid all other careless mistakes that may be the cause of trouble later on.

10.1 AREAS THAT REQUIRE LUBRICATION

NOTE:

Types of lubricants and areas where they are used are listed in table 1.

Table 1

Type of Oil	Areas used
Silicon Oil #500000	EV cam section
GYA-008	all other areas

Lubrication points are specified for greases other than GYA-008. Never use a different type of greases.

- **Cam Section**

Apply grease to the heart-shaped grooved section (rear side of the cam) and lock plate sliding section in order to minimize wear on the sliding section and the burden on the mechanism.

- **Driving Plate Assembly**

Decrease the burden on the mechanism and the wear on the sliding section.

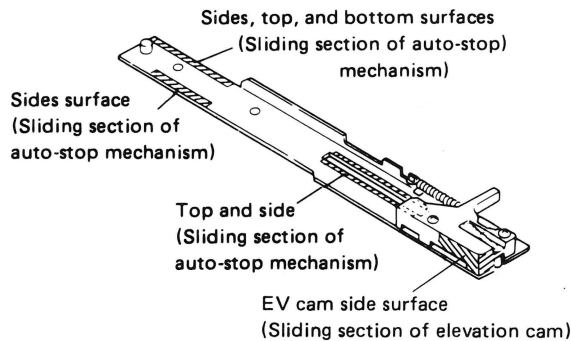

Fig. 10-1 Driving panel assembly section Switch Locker Section

- **Switch Locker Section**

Apply grease to the switch locker (opening) and sub-panel base sliding section to decrease the burden on the mechanism.

When applying grease to the opening (shaft hole), do not apply any grease 2–3mm from the bottom surface. If grease is applied 2–3mm within the bottom surface, it may come out the bottom and go between the switch lever and sub-panel base causing the switch lever to operate ineffectively.

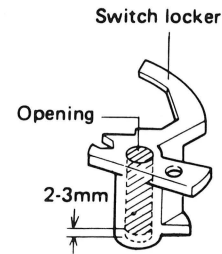

Fig. 10-2 Switch locker section

- **EV Sheet Section**

Apply oil to the raising shaft and sliding section of the bearing to assure stability in the elevation lowering speed.

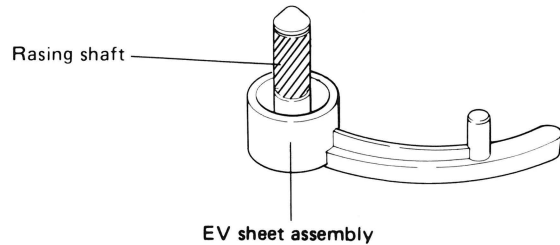

Fig. 10-3 EV sheet section

- **Elevation Cam Section**

Apply silicon oil to the elevation cam and sliding section of the raising shaft to decrease the burden when operated.

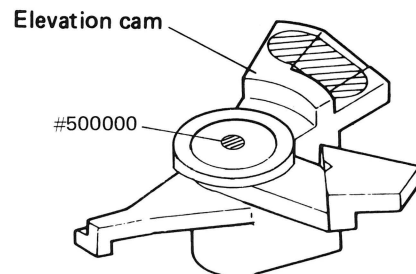

Fig. 10-4 Elevation cam section

● **Index Cam Section**

Apply grease to the index cam lower surface of the hooked section to decrease the burden on the mechanism.

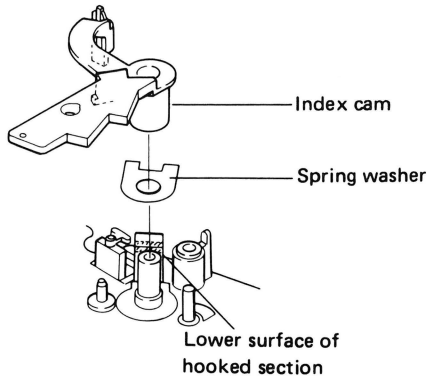

Fig. 10-5 Index cam section

● **Reset Plate Section**

Apply grease to the sub-panel base (shaft) and sliding section of the reset plate to decrease the burden on the mechanism.

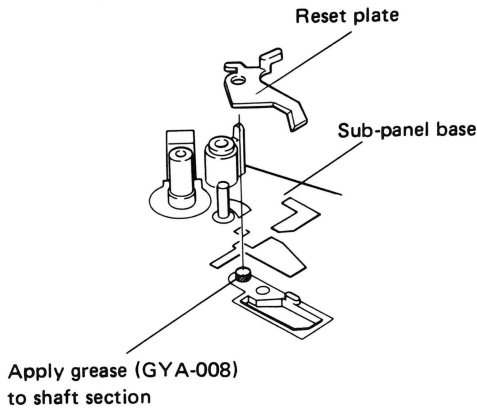
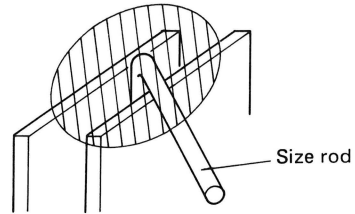

Fig. 10-6 Reset plate section

● **Other Places to be Greased**

1. Where size rod comes in contact with panel's double wall. (Fig. A)
2. Where start/stop rod comes in contact with recessed portion of panel. (Fig. B)
3. Where start lever arm comes in contact with start/stop rod. (Fig. C)



(Fig. A)

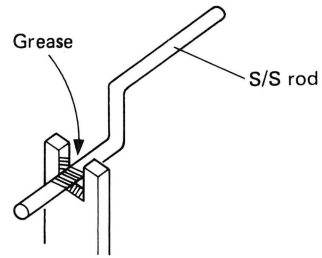

(Fig. B)

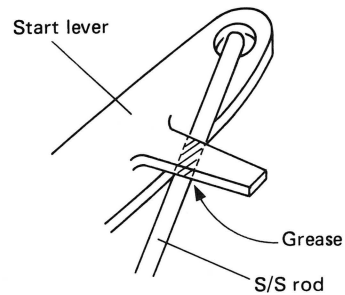

(Fig. C)

Fig. 10-7 Other Places to be Greased

10.2 PRECAUTIONS FOR ATTACHMENT OF PARTS AND REASSEMBLY

● Cam Assembly Attachment

The cam assembly is attached by letting the lock plate go in the direction **A** as shown in Fig. 10-8.

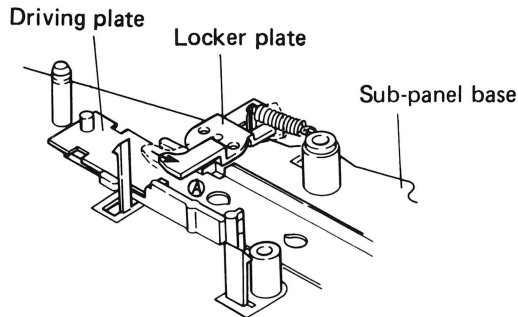

Fig. 10-8 Cam assembly attachment

● PU Plate Assembly Attachment

The PU plate assembly is attached by pushing the PU plate bearing section against the arm rotating shaft fixing nut.

The attachment direction is matched to the center of the support line as shown in Fig. 10-9 (tone arm position on the arm rest).

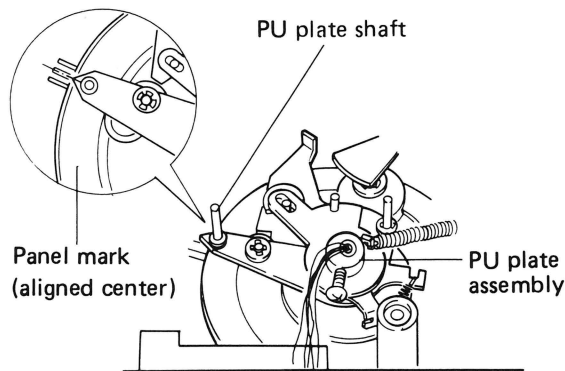

Fig. 10-9 PU plate attachment

● Mechanism Assembly Attachment

1. PU plate shaft position confirmation

When attaching the arm base section to the mechanism section, put the mechanism section switch locker and switch lever in the locked position and verify that the tonearm is in the arm rest location. Also check that the PU plate shaft is in the position shown in Fig. 10-10.

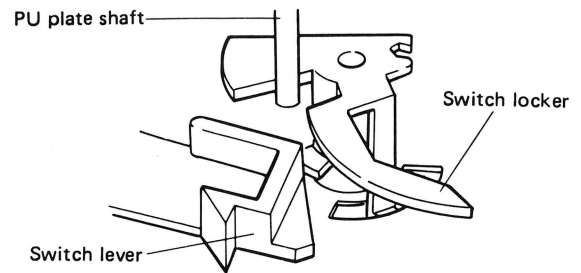

Fig. 10-10 Arm base attachment

2. PU lead wire position confirmation

When attaching the mechanism assembly to the panel, be careful that the PU lead wire is not pinched at the panel boss as shown in Fig. 10-11.

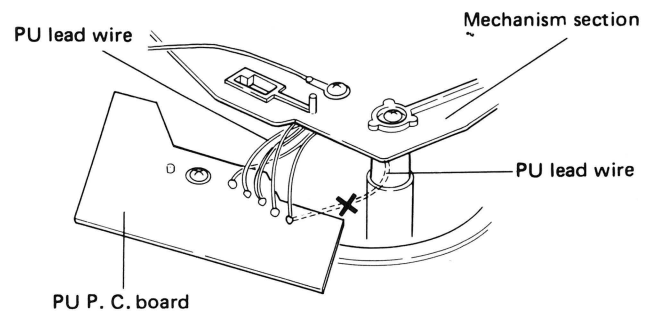

Fig. 10-11 PU lead wire attachment

3. Microswitch lead wire position confirmation

When attaching the mechanism assembly to the panel, be careful that the lead wires do not contact the select lever as shown in Fig. 10-12. If the lead wires contact the select lever, record size detection will malfunction.

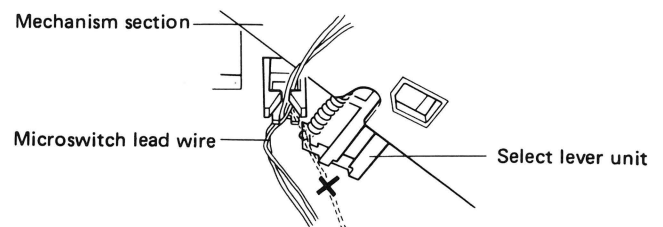

Fig. 10-12 Microswitch lead wire attachment

● **Start Lever Unit Attachment**

Attach the shaft section of the start lever unit as shown in figure 10-13 so that it comes between the reset plate and start panel.

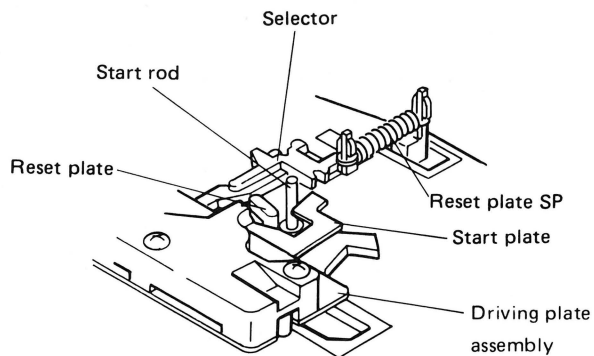

Fig. 10-13 Start lever unit attachment

● **Installing The Cords**

When installing the PU lead wire and DC power cord, install them to the panel with string as shown in Fig. 10-15.

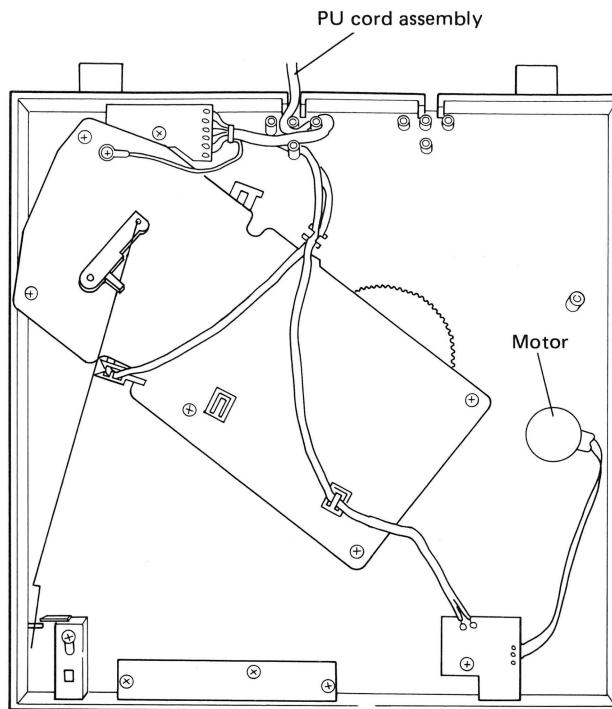

Fig. 10-15 Cords stringing

● **Spindle Assembly Attachment**

When installing the spindle assembly, set the cam in the mechanism stop location and verify that the starting plate section B does not protrude beyond surface A of the cam. If the spindle assembly is attached with the starting plate section B protruding, the starting plate may be deformed, the spindle assembly pinion gear may be scratched, and the return function may be damaged.

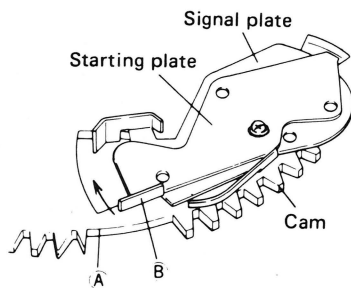

Fig. 10-14 Spindle assembly attachment

11. ADJUSTMENTS

11.1 MOTOR ADJUSTMENTS

Place the record player on blocks as shown in Fig. 11-1 and adjust the motor from the under base.

1. Turn the arm elevation lever up to raise the arm.
2. Place a strobo sheet on the turntable, move the arm to the turntable side, and rotate the turntable.
3. Adjust semifixed resistors VR1 and VR2 of the motor assembly so the strobo of the strobo sheet appears to the static.
4. First adjust VR1 for 45 rpm and then the adjust VR2 for 33 1/3 rpm.

11.2 STYLUS LANDING POSITION ADJUSTMENT

When the tone arm doesn't land in the correct position during automatic playback, adjust according to the following procedure.

1. Place a 30 cm record on the platter.
 2. Press the START/STOP switch and start automatic playback. Note the direction and amount if the landing point is off. (How many mm to the inside or outside from the record grooves.)
 3. Depress the START/STOP switch to return the tone arm to its rest.
 4. Press the arm elevation switch to raise the stylus.
 5. Move the tone arm to the outside edge of the record by hand.
 6. Turn the adjustment screw with a small screwdriver according to the direction and amount checked at item 2 as follows:
 - When the stylus lands at the outside of the record, turn the adjustment screw in the \odot direction.
 - When the stylus lands at the inside of the record, turn the adjustment screw in the \ominus direction.

One half turn of the adjustment screws moves the tone arm about 12mm.
 7. After adjustment, press the PLAY/STOP switch and check if the stylus landing point was correctly adjusted.
- If adjustment is incorrect, repeat items 3 to 6.

Be careful not to damage the record and stylus when making this adjustment.

Adjustment using a test record

(Lowering position adjustment is made with the tone arm on the outside edge of the record.)
30 cm landing point . . . Lands between count 306 and 313.

17 cm landing point . . . Lands between count 175 and 183.

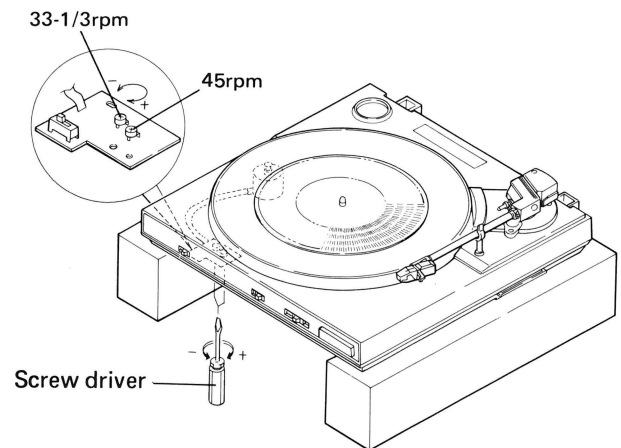

Fig. 11-1 Motor adjustment

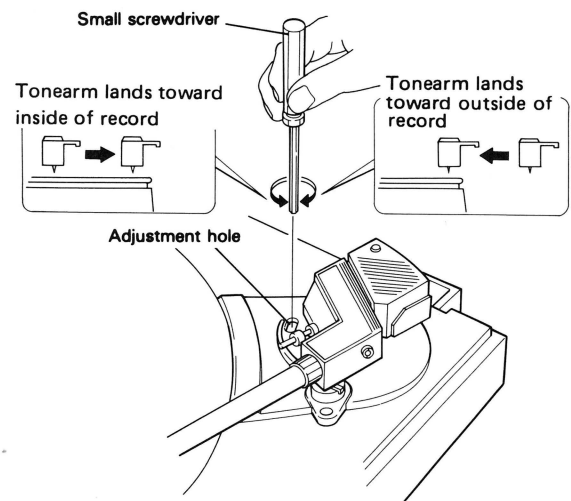

Fig. 11-2 Stylus landing point adjustment

11.3 AUTO-RETURN POSITION ADJUSTMENT

● Auto-Return Position Adjustment

When auto-return occurs too early or too late, make the following adjustments.

1. Check the stylus landing position. If the stylus does not land at the correct position, adjust the landing position.
2. Set the arm elevation switch to UP and turn the auto-return adjustment screw fully counter-clockwise.
3. Move the tone arm as far as it will go toward the inside.
4. When the auto-return adjustment screws is turned slowly clockwise, the tone arm will begin to move toward the inside.
5. Stop turning the adjustment screw at the point at which there is a space of 32 mm between the cartridge stylus and the center shaft. (Fig. 11-3)
6. After adjustment, check that auto-return is performed correctly and that the stylus landing position is correct.

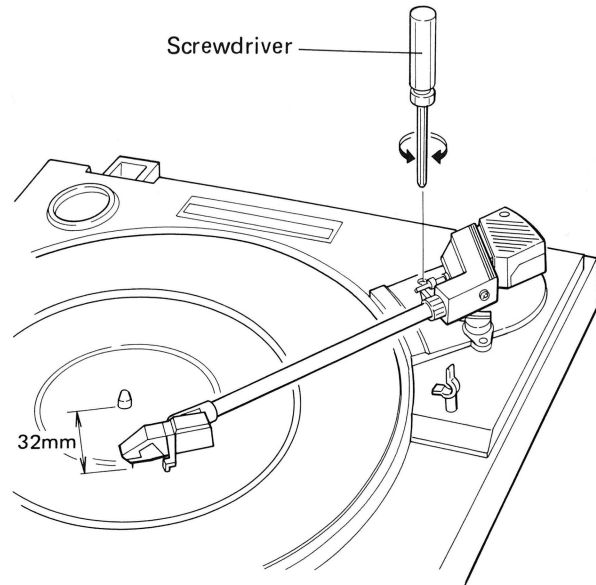

Fig. 11-3 Auto-return position adjustment

11.4 ARM ELEVATION HEIGHT ADJUSTMENT

1. Press the arm elevation switch to move the arm up.
2. Adjust the screw on the side of the arm elevation unit with a philips driver, so that the distance between the record and the stylus is 7 ± 2 mm. The arm moves up when the screw is turned counter clockwise.

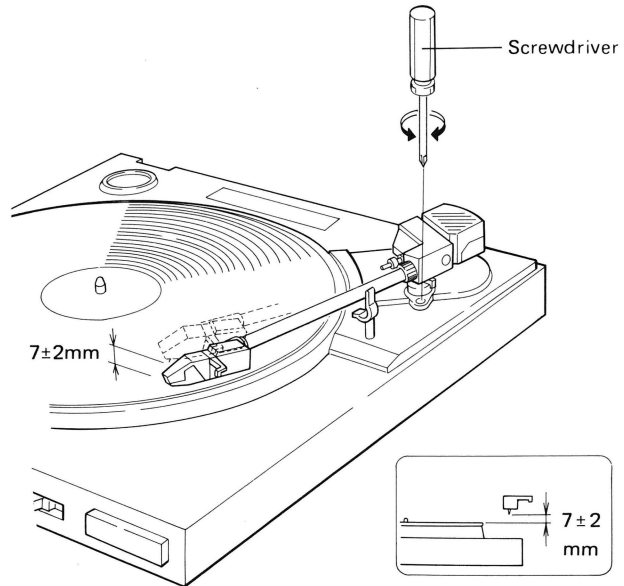

Fig. 11-4 Arm elevation height adjustment

11. RÉGLAGE

11.1 RÉGLAGE DU MOTEUR

Placer le tourne-disques sur des blocs, comme il est montré dans la Fig. 11-1 et régler le moteur depuis le dessous.

1. Tourner le levier de relevage du bras pour soulever le bras de lecture.
2. Placer une feuille stroboscopique sur le tourne-disques; déplacer le bras jusqu'au côté du tourne-disques et le faire tourner.
3. Régler les résistances demi-fixes VR1 et VR2 de l'ensemble du moteur, jusqu'à ce que la feuille stroboscopique apparait immobile.
4. D'abord régler VR1 pour avoir la vitesse de 45 tr/min, ensuite, régler VR2 pour 33 1/3 tr/min.

11.2 RÉGLAGE DE LA POSITION DE DESCENTE DE LA POINTE DE LECTURE

Lorsque le bras de lecture ne descend pas sur la position correcte lors de la lecture automatique, réaliser le réglage en suivant la procédure suivante.

1. Placer un disque de 30cm sur le plateau.
2. Appuyer sur la touche de marche/arrêt (START/STOP) et faire débuter la lecture automatique. Noter la direction et la grandeur de l'écart du point de descente. (Nombre de mm vers l'intérieur ou vers l'extérieur du sillon.)
3. Appuyer sur la touche START/STOP pour faire retourner le bras de lecture sur son support.
4. Appuyer sur la touche de relevage du bras pour soulever la pointe de lecture.
5. Déplacer à la main le bras de lecture vers la périphérie du disque.
6. Tourner la vis de réglage à l'aide d'un petit tournevis, en fonction de la direction et de la quantité mesurées lors du point 2, comme suit:
 - Lorsque la pointe de lecture descend vers l'extérieur du disque, tourner la vis de réglage dans le sens
 - Lorsque la pointe de lecture descend vers l'intérieur du disque, tourner la vis de réglage dans le sens
 Un demi-tour de la vis de réglage correspond à un déplacement d'environ 12mm du bras de lecture.

7. Après le réglage, appuyer sur la touche START/STOP et vérifier si le réglage de la position de descente a été correctement effectué. Si le réglage n'est pas correct, répéter les étapes 3 à 6.

Prendre soin de ne pas endommager le disque ni la pointe de lecture en réalisant ce réglage.

Réglage au moyen d'un disque d'essai

(Le réglage de la position d'abaissement est réalisé avec le bras de lecture placé sur la périphérie du disque.

Point de descente

pour 30cm Descente entre les valeurs 306 et 313.

Point de descente

pour 17cm Descente entre les valeurs 175 et 183.

33-1/3 tr/min.

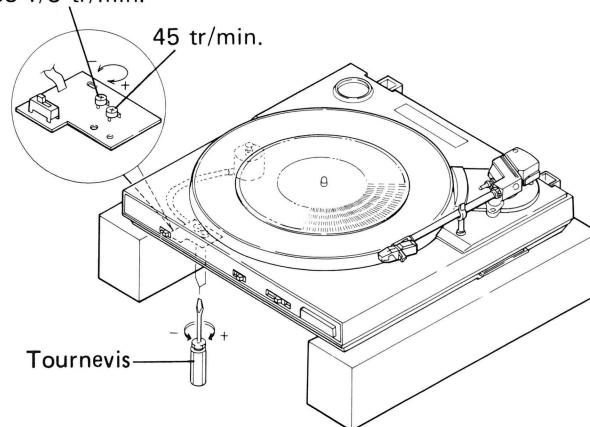

Fig. 11-1 Réglage du moteur

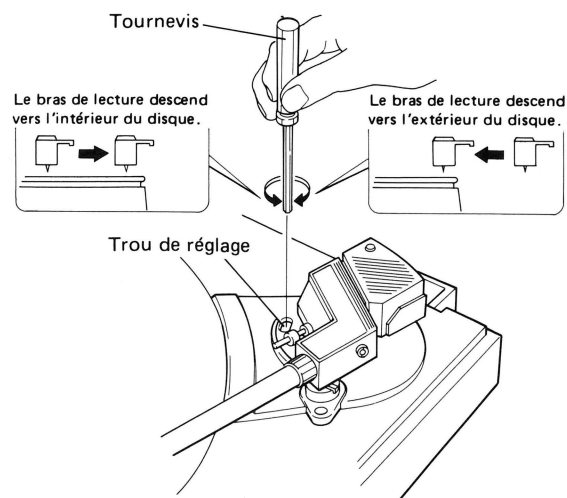

Fig. 11-4 Réglage du point de descente de la pointe de lecture

11.3 RÉGLAGE DE RETOUR AUTOMATIQUE

● Réglage de la position de retour automatique

Réaliser les réglages suivants lorsque le retour automatique se produit tôt ou trop tard.

1. Contrôler la position de descente de la pointe de lecture. Si la pointe de lecture ne descend pas sur la position correcte, ajuster la position de descente.
2. Régler la touche de relevage du bras sur la position "UP" et tourner la vis de réglage du retour automatique à fond dans le sens contraire des aiguilles d'une montre.
3. Déplacer le bras de lecture le plus possible vers l'intérieur.
4. Lorsque la vis de réglage du retour automatique est tournée lentement dans le sens des aiguilles d'une montre, le bras de lecture commence à se déplacer vers l'intérieur.
5. Arrêter de tourner la vis de réglage sur le point pour lequel il y a un écart de 32mm entre la pointe de lecture et l'axe central. (Fig. 11-3)
6. Après le réglage, vérifier que le retour automatique se réalise correctement et que la position de descente de la pointe est correcte.

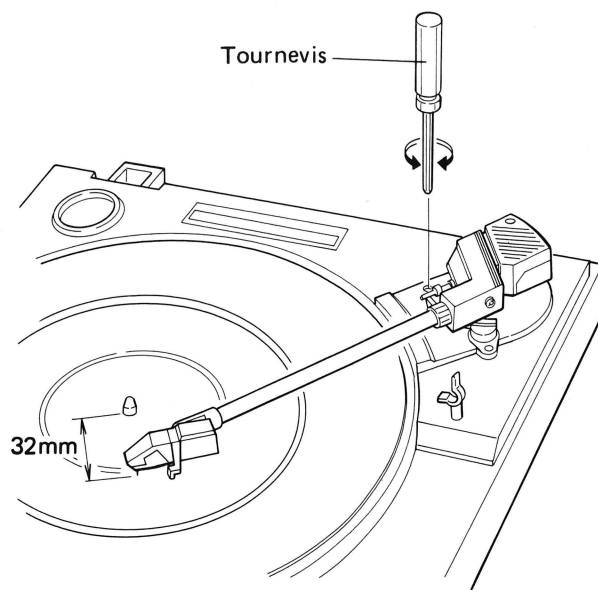

Fig. 11-3 Réglage de retour automatique

11.4 RÉGLAGE DE L'ÉLÉVATION DU BRAS DE PICK-UP

1. Presser le commutateur d'élévation du bras de pick-up pour déplacer le bras vers le haut.
2. Régler la vis du côté du bloc d'élévation du bras au moyen d'un tournevis pour vis à tête (+), de telle sorte que la distance entre le disque et la pointe de lecture soit de 7 ± 2 mm. Le bras se déplace vers le haut lorsque l'on tourne la vis dans le sens contraire des aiguilles d'une montre.

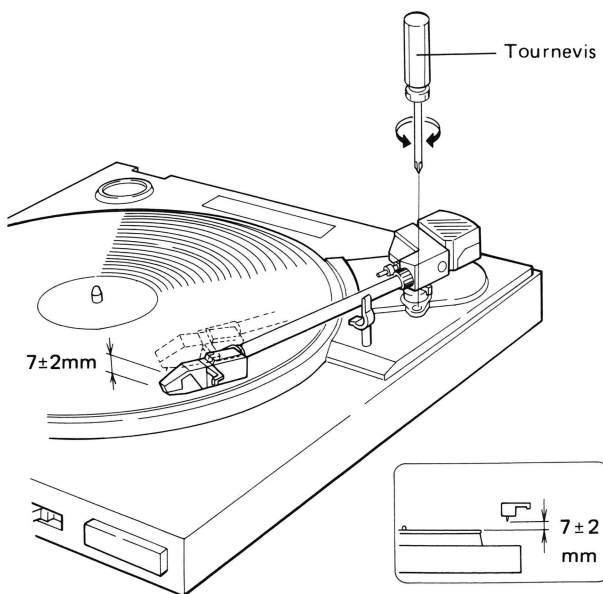

Fig. 11-4 Réglage de l'élévation du bras de pick-up

11. AJUSTE

11.1 AJUSTES DEL MOTOR

Poner el giradiscos sobre bloques como se muestra en la Fig. 11-1 y ajustar el motor desde abajo.

1. Girar la palanca de elevación del brazo para elevar el brazo fonocaptor.
2. Poner una lámina estroboscópica sobre el plato, mover el brazo hacia el plato y hacer girar el plato.
3. Ajustar los resistores semifijos VR1 y VR2 del conjunto del motor de modo que el estrobo y la lámina estroboscópica parezcan parados.
4. Primero ajustar VR1 a 45 rpm luego VR2 a 33 1/3 rpm.

11.2 AJUSTE DE LA POSICIÓN DE DESCENSO DE LA AGUJA

Cuando el brazo fonocaptor no desciende en la posición correcta durante la reproducción automática, ajustar de acuerdo con el procedimiento siguiente.

1. Poner un disco de 30cm sobre el plato.
2. Presionar el interruptor de inicio/parada (START/STOP) e iniciar la reproducción automática. Notar la dirección y cantidad si el punto de descenso es incorrecto. (Cuántos mm hacia el interior o exterior de los surcos del disco.)
3. Presionar el interruptor de inicio/parada (START/STOP) para hacer volver el brazo fonocaptor a su posición de apoyo.
4. Presionar el interruptor de elevación del brazo para hacer ascender la aguja.
5. Desplazar el brazo fonocaptor hacia el borde exterior del disco con la mano.
6. Girar el tornillo de ajuste con un destornillador pequeño de acuerdo con la dirección y cantidad comprobadas en el ítem 2 del modo siguiente:
 - Cuando la aguja desciende fuera del disco, girar el tornillo de ajuste en la dirección
 - Cuando la aguja desciende en el interior del disco, girar el tornillo de ajuste en la dirección

Media vuelta de los tornillos de ajuste desplaza el brazo fonocaptor unos 10mm.
7. Después del ajuste, presionar el interruptor de reproducción/parada (PLAY/STOP) y comprobar si el punto de descenso de la aguja se ha ajustado correctamente. Si el ajuste es incorrecto, repetir los ítems 3 al 6.

Tener cuidado de no dañar el disco ni la aguja al efectuar este ajuste.

Ajuste empleando un disco de prueba

(El ajuste de la posición de descenso se efectúa con el brazo fonocaptor sobre su borde exterior del disco.)

Punto de descenso para 30cm Desciende entre el cómputo 306 y 313.

Punto de descenso para 17cm Desciende entre el cómputo 175 y 183.

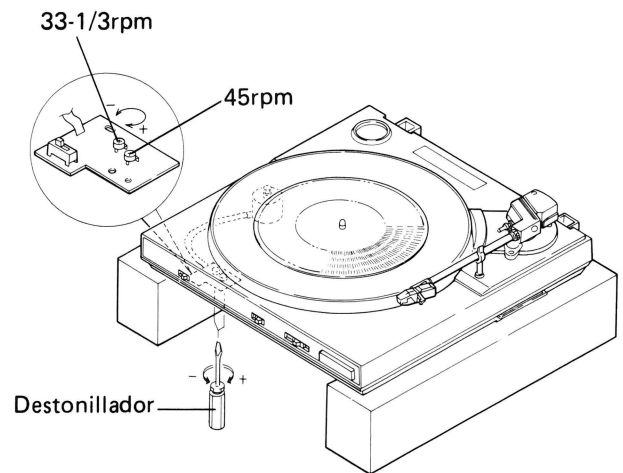

Fig. 11-1 Ajuste del motor

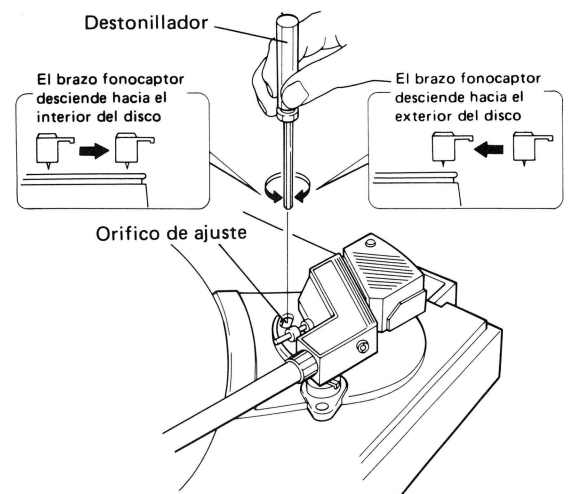

Fig. 11-2 Ajuste del punto de descenso de la aguja

11.3 AJUSTE DE RETORNO AUTOMÁTICO

• Ajuste de la posición de retorno automático

Cuando el retorno automático se produce demasiado rápido o demasiado tarde, efectuar los ajustes siguientes.

1. Comprobar la posición de descenso de la aguja. Si la aguja no desciende en la posición correcta, ajustar la posición de descenso.
2. Ajustar el interruptor de elevación del brazo en la posición UP y girar el tornillo de ajuste de retorno automático completamente hacia la izquierda.
3. Desplazar el brazo fonocaptor hacia el interior al máximo.
4. Cuando se giran lentamente los tornillos de ajuste de retorno automático hacia la derecha, el brazo fonocaptor empezará a moverse hacia el interior.
5. Dejar de girar el tornillo de ajuste en el punto en el que haya un espacio de 32mm entre la aguja de la cápsula y el eje central. (Fig. 11-3)
6. Después del ajuste, comprobar que la operación de retorno automático se efectúe correctamente y que la posición de descenso de la aguja sea la correcta.

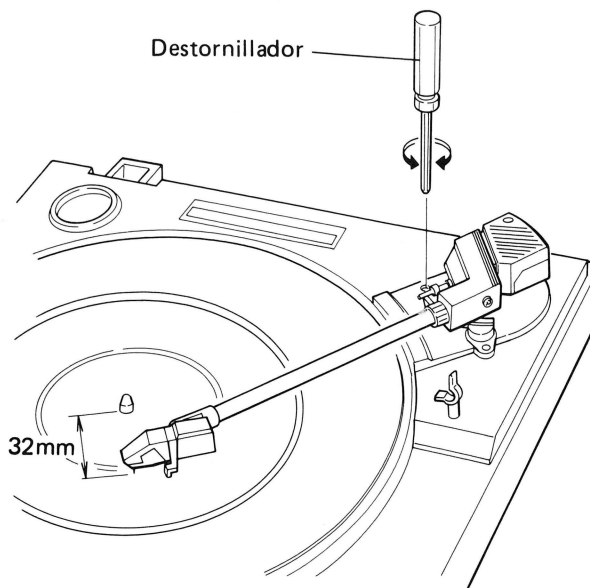

Fig. 11-3 Ajuste de retorno automático

11.4 AJUSTE DEL BRAZO DE FONOCAPTOR

1. Presionar el conmutador de elevación del brazo de fonocaptor para desplazar el brazo hacia arriba.
2. Ajustar el tornillo en el lado de la unidad de elevación del brazo por medio de un destornillador de tipo (+), de modo que la distancia entre el disco y la aguja sea de 7 ± 2 mm. El brazo se desplaza hacia arriba girando el tornillo en sentido contrario al de las agujas del reloj.

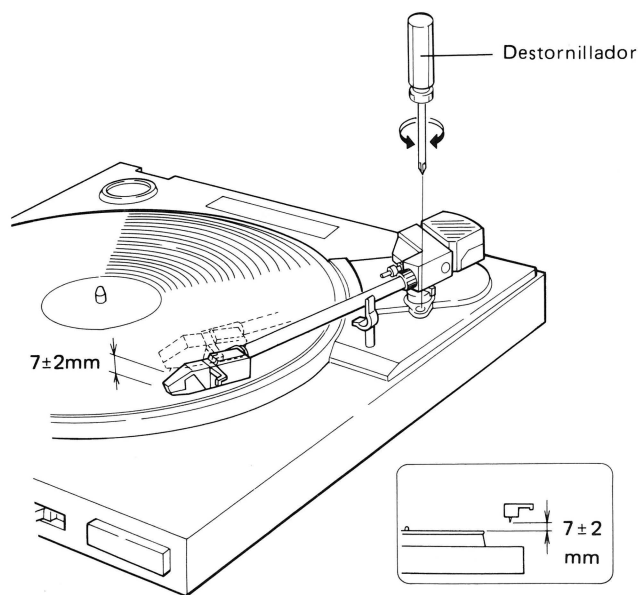

Fig. 11-4 Ajuste del brazo de fonocaptor

12. FOR Z/G, AND Z/E TYPES

Contrast of Miscellaneous Parts

PL-55Z (BK)/Z/G and PL-X55Z/Z/E types are the same as the PL-X55Z (BK)/ZUEM type except for following sections.

MISCELLANEOUS PARTS

Mark	Symbol & Description	Part No.			Remarks
		PL-X55Z(BK)/ZUEM	PL-X55Z(BK)/Z/G	PL-X55Z/ZE	
	Front name plate	PAM-206	PAM-206	PAM-221	
	Panel	PNY-623	PNY-623	PNY-614	
	S/S button	PAC-344	PAC-344	PAC-364	
	Packing case	PHH-335	PHH-335	PHH-352	

