

**TOSHIBA**

FILE NO. 020-9405

SERVICE MANUAL  
FULL EDITION  
N4SS

**COLOR TELEVISION**

***CF35D50***

(TAC9411)

***TV35D50***

(TAC9415)

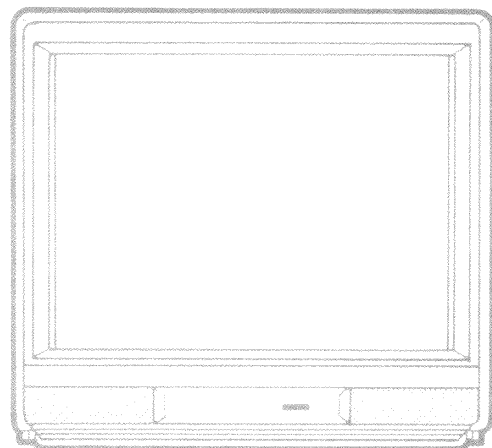

PRINTED IN JAPAN, Sep., 1994 ©

## X-RAY RADIATION PRECAUTION

1. Excessive high voltage can produce potentially hazardous X-RAY RADIATION. To avoid such hazards, the high voltage must not be above the specified limit. The nominal value of the high voltage of this receiver is 31.8 kV at zero beam current (minimum brightness) under a 120V AC power source. The high voltage must not, under any circumstances, exceed 33.2 kV. Each time a receiver requires servicing, the high voltage should be checked following the HIGH VOLTAGE CHECK procedure in this manual. It is recommended that the reading of the high voltage be recorded as a part of the service record. It is important to use an accurate and reliable high voltage meter.
2. This receiver is equipped with a Fail Safe (FS) circuit which prevents the receiver from producing

an excessively high voltage even if the B+ voltage increases abnormally. Each time the receiver is serviced, the FS circuit must be checked to determine that the circuit is properly functioning, following the FS CIRCUIT CHECK procedure in this manual.

3. The only source of X-RAY RADIATION in this TV receiver is the picture tube. For continued X-RAY RADIATION protection, the replacement tube must be exactly the same type tube as specified in the parts list.
4. Some part in this receiver have special safety-related characteristics for X-RAY RADIATION protection. For continued safety, parts replacement should be undertaken only after referring to the PRODUCT SAFETY NOTICE below.

## SAFETY PRECAUTION

**WARNING :** Service should not be attempted by anyone unfamiliar with the necessary precautions on this receiver. The following are the necessary precautions to be observed before servicing this chassis.

1. An isolation Transformer should be connected in the power line between the receiver and the AC line before any service is performed on the receiver.
2. Always discharge the picture tube anode to the CRT conductive coating before handling the picture tube. The picture tube is highly evacuated and if broken, glass fragments will be violently expelled. Use shatter proof goggles and keep picture tube away from the unprotected body while handling.
3. When replacing a chassis in the cabinet, always be certain that all the protective devices are put back in place, such as; non-metallic control knobs, insulating covers, shields, isolation resistor-capacitor network etc.
4. Before returning the set to the customer, always perform an AC leakage current check on the exposed metallic parts of the cabinet, such as antennas, terminals, screwheads, metal overlays, control shafts etc. to be sure the set is safe to operate without danger of electrical shock. Plug the AC line cord directly into a 120V AC outlet (do not use a line isolation transformer during this check). Use an AC voltmeter having 5000 ohms per volt or more sensitivity in the following manner:

Connect a 1500 ohm 10 watt resistor, paralleled by a 0.15 mfd, AC type capacitor, between a known good earth ground (water pipe, conduit, etc.) and the exposed metallic parts, one at a time. Measure the AC voltage across the combination of 1500 ohm resistor and 0.15 mfd capacitor. Reverse the AC plug at the AC outlet and repeat AC voltage measurements for each exposed metallic part. Voltage measured must not exceed 0.3 volts RMS. This corresponds to 0.2 milliamp. AC. Any value exceeding this limit constitutes a potential shock hazard and must be corrected immediately.

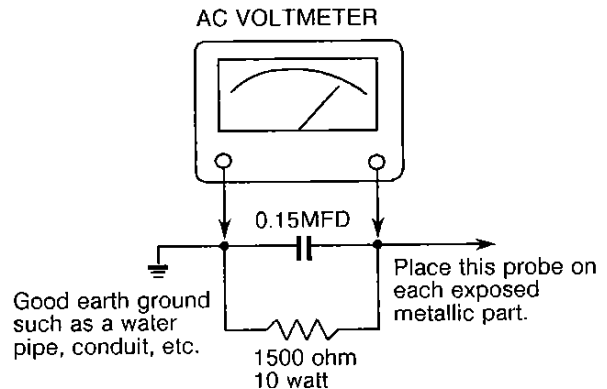

## PRODUCT SAFETY NOTICE

Many electrical and mechanical parts in this chassis have special safety-related characteristics. These characteristics are often passed unnoticed by a visual inspection and the protection afforded by them cannot necessarily be obtained by using replacement components rated for higher voltage, wattage, etc. Replacement parts which have these special safety characteristics are identified in this manual and its supplements; electrical components having such features are identified by the international hazard symbols on the schematic diagram and the parts list.

Before replacing any of these components, read the parts list in this manual carefully. The use of substitute replacement parts which do not have the same safety characteristics as specified in the parts list may create shock, fire, X-ray radiation or other hazards.

# LOCATION OF CONTROLS (TV set)

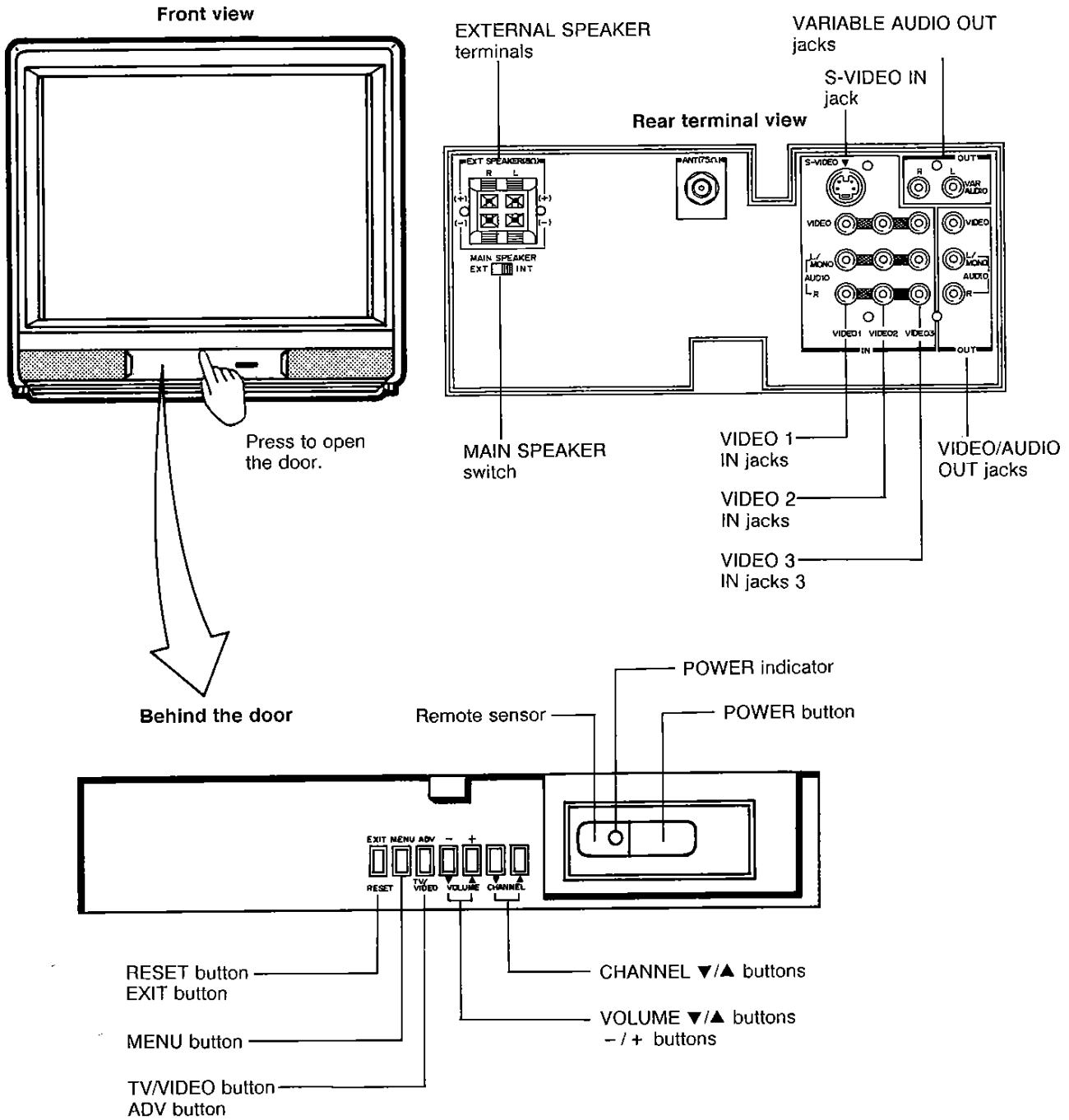

# LOCATION OF CONTROLS (Remote Control)

Only the buttons that are used to operate the TV set are described here.

Aim at the remote sensor on the TV set

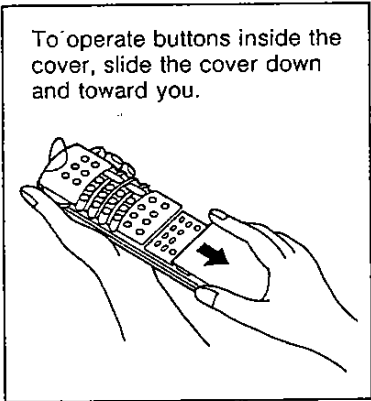
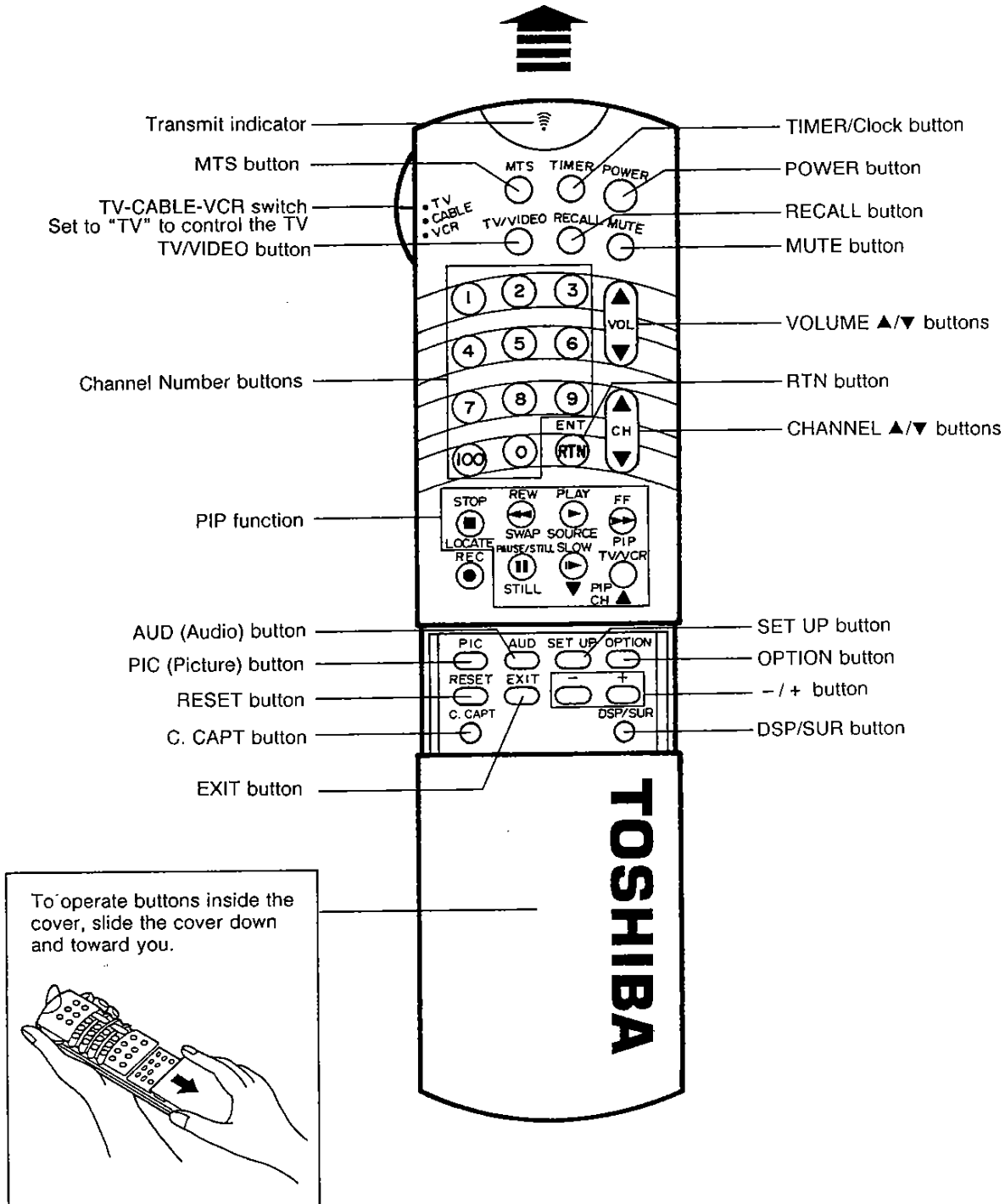

## USING THE REMOTE WITH VCR OR CABLE TV CONVERTER

- To control TOSHIBA VCR, first set the TV-CABLE-VCR switch to "VCR" position. The buttons shown below will then control the VCR. The rest of the buttons operate the TV as usual.  
If you have another brand of VCR, you can probably program your Remote to control it.
- To control a cable TV converter, this Remote Control must be programmed to recognize the brand of your converter.  
Set the TV-CABLE-VCR switch to "CABLE" position whenever you control the cable TV converter.

Aim at the VCR or cable TV converter

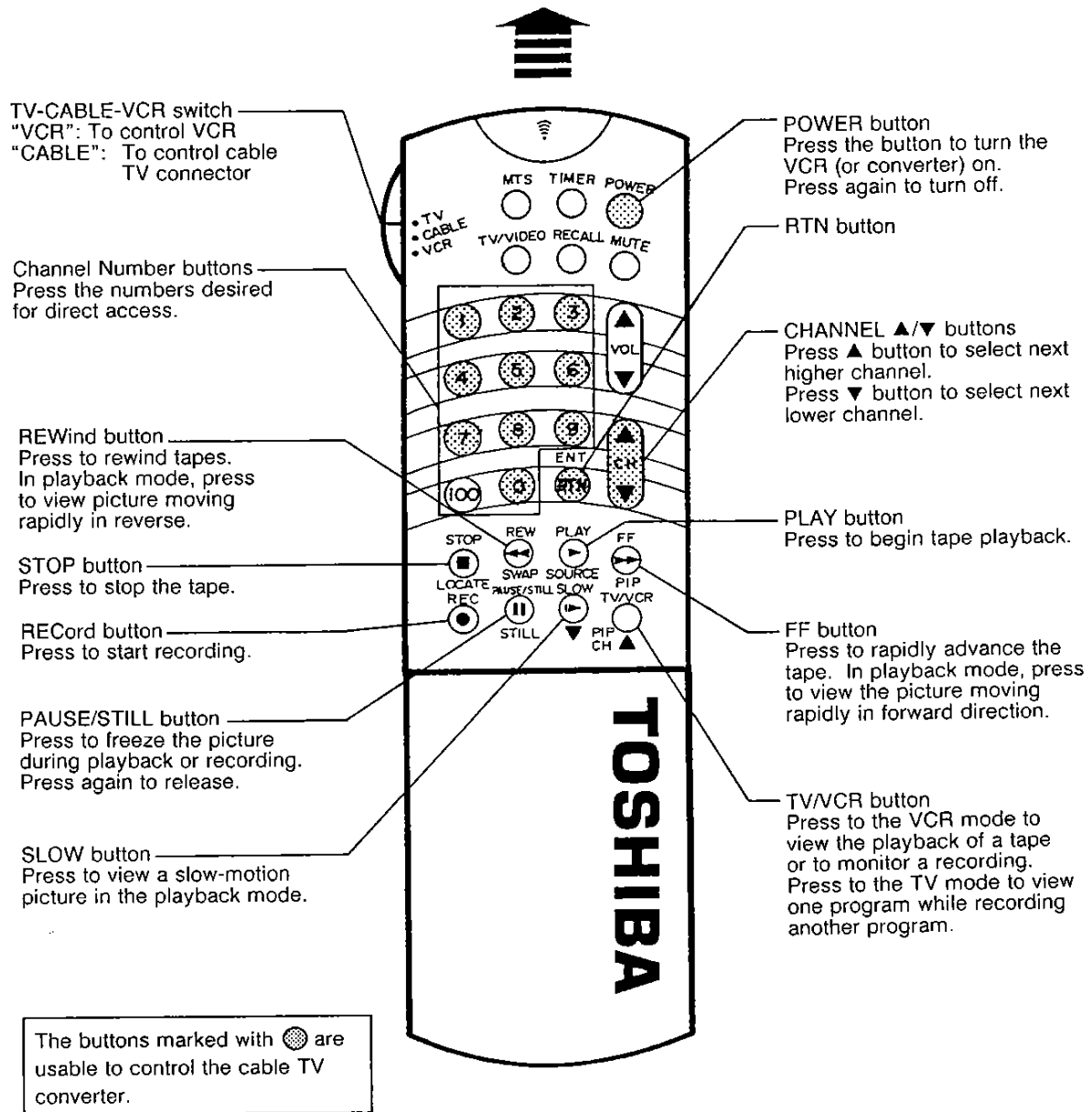

## PROGRAMMING THE REMOTE CONTROL

- This Remote Control is preprogrammed to operate TOSHIBA VCR's.
- To use VCR's other than Toshiba models (or Cable converters), perform the following procedures before operating.

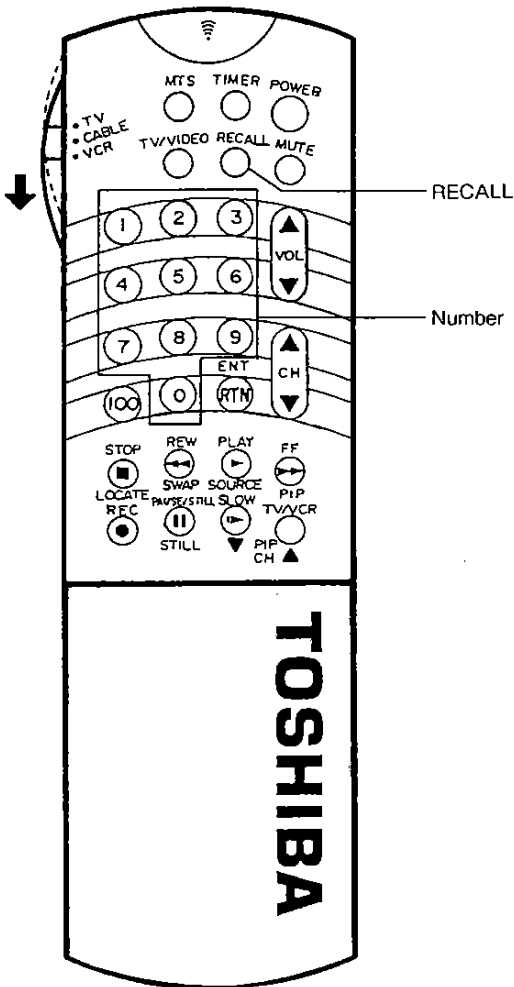

### TO CONTROL OTHER BRANDS OF VCR'S AND CABLE TV CONVERTERS

- 1 Refer to the "VCR CODE TABLE" (or "CABLE TV CONVERTER CODE TABLE") on pages 8 to 10 to find the code number that corresponds to the brand name of your VCR (or your converter).

If more than one number is listed, try each one separately until you find the one that works.

- 2 Set the TV-CABLE-VCR switch to VCR (or CABLE).

- 3 Hold down **RECALL** while pressing the **Number buttons** for the three digit code number for your brand of VCR (or converter). The transmit indicator lights up for 1 second when the programming is completed.

When an operation error has occurred, the indicator blinks. Press **RECALL** again to reset.

- 4 Point the Remote Control at the VCR (or at the converter) and press **POWER** to test the code number.
  - If the right number was entered, the VCR should turn on.
  - If the VCR does not respond to the Remote Control, repeat steps 1 to 4 with another code number.

#### Notes:

- You have to reprogram the Remote Control when you change its batteries.
- Some newer VCR's are capable of working on either of two remote codes. These VCR's have a switch labeled "VCR1/VCR2".

If your VCR has this kind of switch, and does not respond to all the code numbers for your VCR brand name, set the switch to another position ("VCR1" or "VCR2") and reprogram the Remote Control.

For future reference, write the code you used.

VCR CODE: \_\_\_\_\_

CABLE CODE: \_\_\_\_\_

VCR CODE TABLE

BRAND NAME	CODE NUMBER	BRAND NAME	CODE NUMBER
Aiko .....	297	Graetz.....	060, 123
Aiwa.....	019	Granada .....	065, 100, 123
Akai.....	060, 068, 080, 125, 261	Grundig.....	100
Alba .....	039, 228, 297	Harman/Kardon .....	057
Amstrad.....	019	Hem.....	091
Anitech.....	091	Hinari.....	091, 227
ASA .....	056, 100	Hitachi .....	019, 060, 061, 084, 124
Audiovox.....	056	Imperial .....	019
Baird.....	123	Interfunk.....	100
Bell & Howell.....	123	ITT .....	060, 065, 123, 125
Broksonic.....	140, 203, 230	JCL .....	054
Bush .....	091, 228, 297	Jensen.....	060
Canon.....	054	JVC.....	027, 060, 086
Capehart.....	039	Kendo.....	125
Carver.....	100	Kenwood .....	057, 060, 065, 086
CCE .....	091, 297	Lloyd .....	019
CGE.....	019	Loewe.....	056
Cimline.....	091	Loewe Opta .....	100
Condor .....	039	Logik.....	019, 259
Craig .....	066, 259	Luxor .....	062, 065, 125
Crown.....	297	LXI .....	056
Curtis Mathes.....	054	Magnavox .....	019, 054, 100, 129, 168
Daewoo .....	039, 064, 065, 297	Manesth.....	064, 091
Dansai .....	091	Marantz.....	054, 057, 081, 100
Daytron .....	039	Marta .....	056
De Graaf.....	061	Matsui.....	227, 228
Decca .....	019, 100	MEI .....	054
Dual.....	060	Memorex.....	019, 054, 056, 058, 065, 066, 067, 123
Dumont .....	019, 100, 123, 124	MGA .....	062, 080
Dynatech.....	019	Minolta .....	061, 124
Electronic.....	019	Mitsubishi .....	062, 080, 086, 100, 192, 233, 261
Emerson.....	019, 021, 056, 080, 140, 203, 227, 228, 230, 231, 313	MTC .....	019, 259
ESC .....	297	Multitech .....	019, 091
Ferguson.....	060	Murphy.....	019
Fidelity .....	019	NEC.....	057, 059, 060, 069, 086
Finlandia .....	100, 123, 129	Neckermann .....	100
Finlux.....	019, 061, 100, 123, 124	Nikko .....	056
First Line.....	062, 091	Noblex.....	259
Fisher .....	065, 066, 073, 085, 123	Nokia .....	060, 065, 123, 125, 259
Frontech.....	039	Nordmende.....	060
Funai .....	019	Optonica.....	067, 081
GE .....	054, 079, 084	Orion.....	140, 227, 228
GEC.....	100	Osaki .....	019, 056, 091
General .....	071	Otto Versand .....	100
Go Video.....	251, 298	Pallidium .....	091
Goldstar .....	056, 057	Panasonic .....	054, 096, 244
Goodmans .....	019, 039, 056, 081, 091, 297	Penney.....	054, 056, 057, 059, 061, 259
Gradiente .....	019		

**VCR CODE TABLE**

<b>BRAND NAME</b>	<b>CODE NUMBER</b>	<b>BRAND NAME</b>	<b>CODE NUMBER</b>
Pentax .....	061, 084, 124	SEI .....	100
Perdio .....	019	Sentra .....	039
Philco .....	054	Sharp .....	076, 081
Philips .....	054, 081, 100, 129	Shintom .....	091
Phonola .....	100	Siemens .....	056, 123
Pilot .....	056	Sinudyne .....	100
Pioneer .....	086, 100	Sony .....	051, 052, 053, 054
Portland .....	039	STS .....	061
Proline .....	019	Sunstar .....	019
Pulsar .....	058	Sylvania .....	054, 062, 100, 129
Pye .....	100	Symphonic .....	019
Quartz .....	065	Tashiko .....	019
Quasar .....	054, 115	Tatung .....	019, 060, 100
Quelle .....	100	Teac .....	019, 060
Radiola .....	100	Technics .....	054
RCA .....	054, 061, 084, 096, 124, 168, 221	Teknika .....	019, 054, 056, 071
RCA Unified .....	079	Telefunken .....	060, 206
Realistic .....	019, 054, 056, 065, 066, 067, 081, 085, 123, 259	Tenosal .....	091
Rex .....	060	Tensai .....	019
Ricoh .....	053	Thomson .....	060
Roadstar .....	056, 091, 259	Thorn .....	060
Runco .....	058	Toshiba .....	060, 062, 064, 085, 229, 231, 385
Saba .....	060	Totevision .....	056, 259
Saisho .....	227, 228	Triumph .....	227
Salora .....	062, 065, 125	Unitech .....	259
Samsung .....	064, 259	Universum .....	019, 056, 068, 100, 125
Sansui .....	060, 086	Vector Research .....	057, 059
Sanyo .....	065, 066, 123, 259	Victor .....	027, 060, 086
SBR .....	100	Video Concepts .....	059, 080
Schaub Lorenz .....	019, 060	Videosonic .....	259
Schneider .....	019, 091, 100, 129	Wards .....	019, 054, 061, 066, 067, 081, 091, 168, 231, 259
Scott .....	064, 140, 203, 229, 231	Yamaha .....	057, 060
Sears .....	054, 056, 061, 065, 066, 073, 085, 123, 124	Yoko .....	259
		Zenith .....	052, 053, 058

**CABLE TV CONVERTER CODE TABLE**

<b>BRAND NAME</b>	<b>CODE NUMBER</b>	<b>BRAND NAME</b>	<b>CODE NUMBER</b>
ABC.....	026, 030, 032, 036	Pulsar.....	019
Archer.....	058, 172	PVP Stereo Visual Matrix.....	022
Century.....	172	RCA.....	040
Citizen.....	172	Regal.....	039, 278, 292
Colour Voice.....	044, 050	Regency.....	021
Comtronics.....	059, 079	Rembrandt.....	089
Eastern.....	021	Runco.....	029
Garrard.....	172	Samsung.....	059, 163
Gemini.....	034, 089	Scientific Atlanta.....	025, 027, 036, 296
General Instrument.....	030	Signal.....	034, 059
Hamlin.....	028, 039, 278, 292	Signature.....	030
Hitachi.....	030	SL Marx.....	059
Jasco.....	172	Sprucer.....	040
Jerrold.....	022, 030, 031, 033, 034, 043, 045	Standard Components.....	174
Macom.....	052	Starcom.....	022, 034
Magnavox.....	046	Stargate.....	034, 059
Memorex.....	019	STS.....	175
Movie Time.....	175	Tocom.....	031, 032, 078
NSC.....	089, 175	Toshiba.....	019
Oak.....	026, 038	Unika.....	172
Panasonic.....	040	United Artists.....	026
Paragon.....	019	United Cable.....	022
Philips.....	044, 046, 047, 048, 049, 050, 079	Universal.....	058, 096, 172, 210
Pioneer.....	163	Viewstar.....	046, 079
		Zenith.....	019

## MENU FUNCTION (General Instructions)

We suggest you familiarize yourself with the procedure before using the Menu function.  
To adjust any TV feature, the use of the Menu function is required. The adjustments that can be made to the TV appear on the screen.

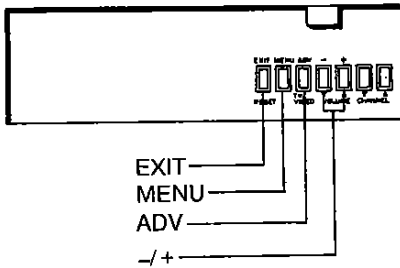

### MENU BUTTON (on TV)

Each time you press **MENU**, the Picture, Audio, Set up or Option menu on-screen display is selected in order, then press **ADV**.

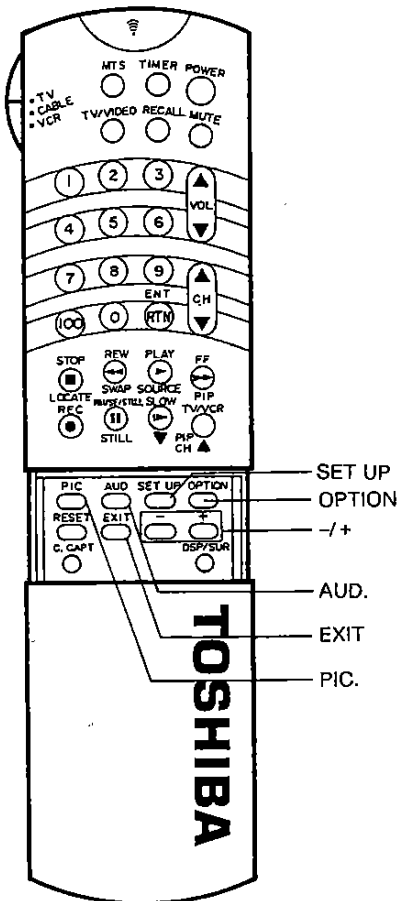
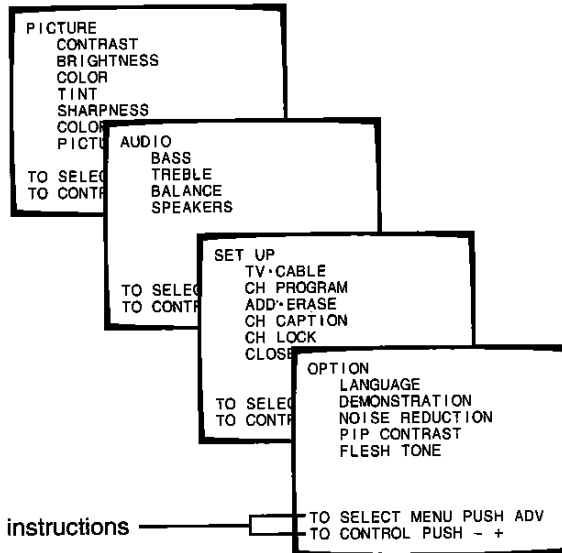

### ADV BUTTON (on TV)

Use this **ADV** after you have pressed **MENU** to select the function you want to adjust.  
Each time you press **ADV**, the function to be adjusted will be selected in order.  
The selected function will be displayed in magenta.

### -/+ BUTTONS (on TV and on Remote)

Use these **-/+** after you have pressed **ADV** or any of the four menu buttons (**PIC**, **AUD**, **SET UP** or **OPTION**).

**Example:** CONTRAST adjustment mode display

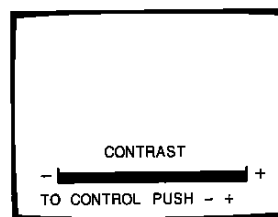

Pressing **+** increases the picture contrast.  
Pressing **-** decreases the picture contrast.

**PIC (Picture) BUTTON (on Remote)**

Press **PIC**. repeatedly until the Picture menu function you want to adjust is selected.

The selected function will be displayed in magenta, then press **-/+** to adjust the setting.

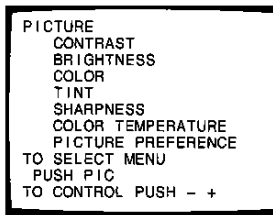

**AUD (Audio) BUTTON (on Remote)**

Press **AUD**. repeatedly until the Audio menu function you want to adjust is selected.

The selected function will be displayed in magenta, then press **-/+** to adjust the setting.

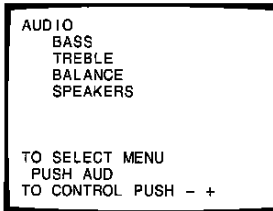

**SET UP BUTTON (on Remote)**

Press **SET UP** repeatedly until the Set up menu function you want to adjust is selected.

The selected function will be displayed in magenta, then press **-/+** to adjust the setting.

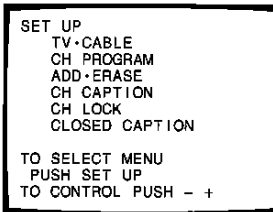

**OPTION BUTTON (on Remote)**

Press **OPTION** repeatedly until the Option menu function you want to adjust is selected.

The selected function will be displayed in magenta, then press **-/+** to adjust the setting.

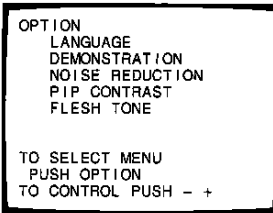

**EXIT BUTTON (on Remote)**

The above four menu displays will automatically disappear from the screen if no control has been operated for about 15 seconds, and all other menu displays also disappear after about 6 seconds.

If you want to clear the screen of all on-screen displays instantly, press **EXIT** button.

**Notes:**

- The ADV button on the TV set will function as the TV/VIDEO button when no menu display is on the screen.
- The **-/+** buttons on the TV set will function as the VOLUME **▼/▲** buttons when no menu display is on the screen.
- The EXIT button on the TV will function as the RESET button when no menu display is on the screen.

**WARNING: BEFORE SERVICING THIS CHASSIS, READ THE "X-RAY RADIATION PRECAUTION", "SAFETY PRECAUTION" AND "PRODUCT SAFETY NOTICE" ON PAGE 2 OF THIS MANUAL.**

## SET-UP ADJUSTMENT

- The following adjustments should be made when a complete realignment is required or a new picture tube is installed.

Perform the adjustments in order as follows :

1. Color Purity
2. Convergence
3. CRT Gray Scale

Note: The PURITY/CONVERGENCE MAGNET assembly and rubber wedges need mechanical positioning.  
Refer to figure 1.

### COLOR PURITY ADJUSTMENT

NOTE : Before attempting any purity adjustments, the receiver should be operated for at least fifteen minutes.

1. Receive all-white signal with a color bar/pattern generator.
2. Evenly degauss the entire screen.
3. Set the CONTRAST and BRIGHTNESS Controls to the maximum.
4. Make the raster a single color in green using short jumpers. (See the next page.)
5. Loosen the clamp screw holding the deflection yoke (and remove the rubber Wedges).
6. Slide the yoke forward or backward to provide vertical green belt (zone) in the picture screen.
7. Rotate and spread the tabs of the purity magnet (See figure 3.) around the neck of the picture tube until the green belt is in the center of the screen. At the same time, center the raster vertically by adjusting the magnet as shown below.

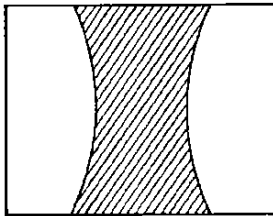

Green Belt

8. Move the yoke slowly forward or backward until a uniform green screen is obtained. Tighten the clamp screw of the yoke temporarily.
9. Check the purity of the red and blue raster.
10. Put four wedges into the space between the picture tube and the yoke to hold the yoke in the adjusted position. (See figure 2.)  
Do not tilt the yoke by excessive insertion of the wedge.
11. Remove cover paper of wedge and stick wedges on the tube to fix the yoke in the adjusted position. Fix the wedges with glass cloth tapes.

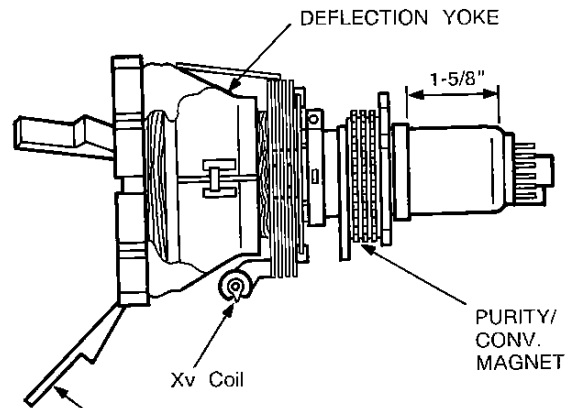

Figure. 1

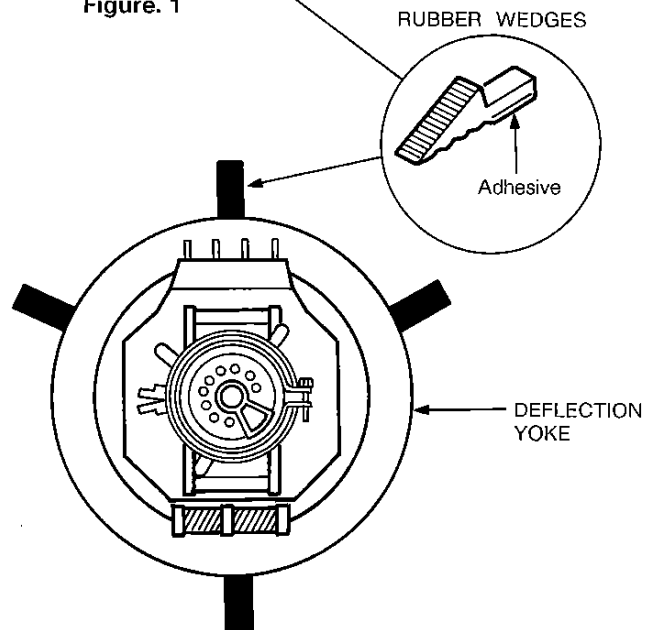

Figure 2.

## CONVERGENCE ADJUSTMENTS

NOTE: Before attempting any convergence adjustments, the receiver should be operated for at least fifteen minutes.

### ■ CENTER CONVERGENCE ADJUSTMENT

1. Receive crosshatch pattern from a color bar/pattern generator.
2. Adjust the BRIGHTNESS and CONTRAST Controls for well defined pattern.
3. Loosen the tightening ring and adjust two tabs of the 4-Pole Magnets to change the angle between them (See figure 3.) and superimpose red and blue vertical lines in the center area of the picture screen. (See figure 4.)
4. Turn the both tabs at the same time keeping the constant angle to superimpose red and blue horizontal lines at the centre of the screen. (See figure 4.)
5. Adjust two tabs of 6-Pole Magnets to superimpose red/blue line with green one. Adjusting the angle affects the vertical lines and rotating both magnets affects the horizontal lines.
6. Repeat adjustments 3, 4, 5 keeping in mind red, green and blue movement, because 4-Pole Magnets and 6-Pole magnets interact and make dot movement complex.
7. After completing the "CENTER CONVERGENCE ADJUSTMENT" tighten the tightening ring to fix the magnets.

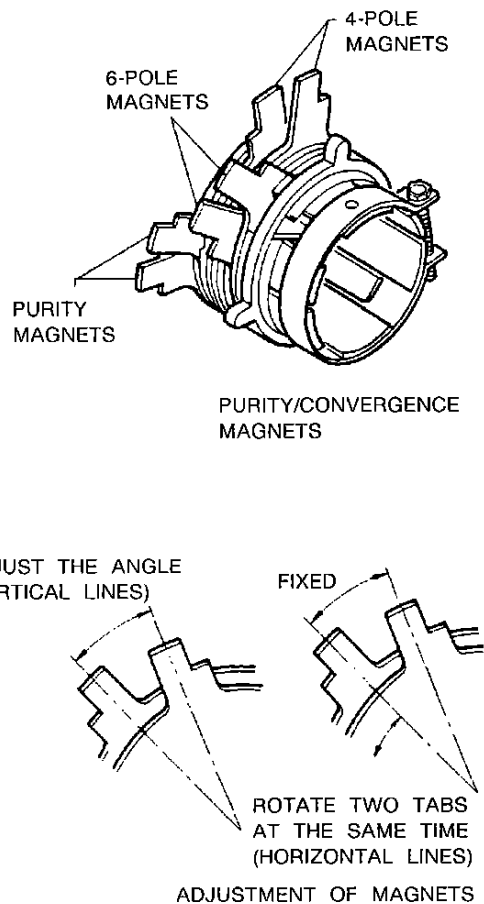
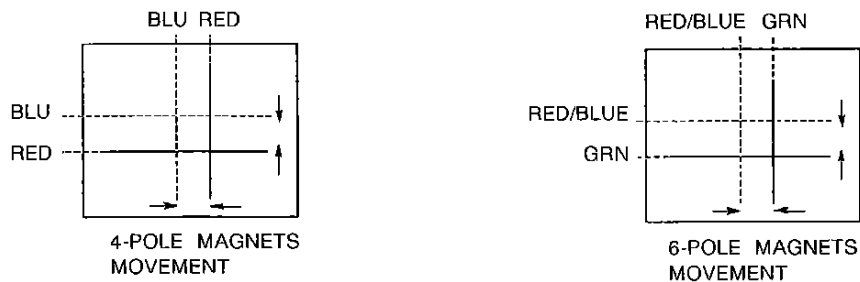

Figure 3.



Center Convergence by Convergence Magnets

Figure 4.

■ **X<sub>v</sub> COIL ADJUSTMENT**

Adjust the X<sub>v</sub> coil (on the deflection yoke) to correct misconvergence at both sides on screen. (See the right figure.)  
Use a hexagonal tip stick (plastic) to adjust the core of coil.

**Clockwise Adjustment**

**Counterclockwise Adjustment**

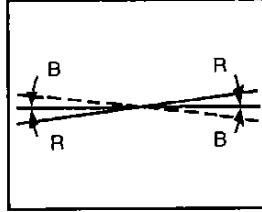
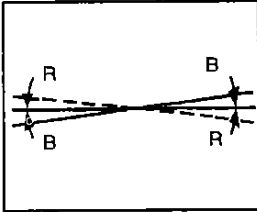

**X<sub>v</sub> Cross Pattern View**

■ **SCREEN-CORNER CONVERGENCE**

When the misconvergence is still evident on corners even though the above adjustment is done, use the ferrite sheet (Part No. 23993622) to correct misconvergence.

1. Put ferrite sheets into the space under the yoke.  
Decide such position that misconvergence becomes minimum, watching picture screen. (See figure below.)
2. Remove cover paper of ferrite sheet to stick it in the place on the tube. Put adhesive tapes on ferrite sheets to fix.

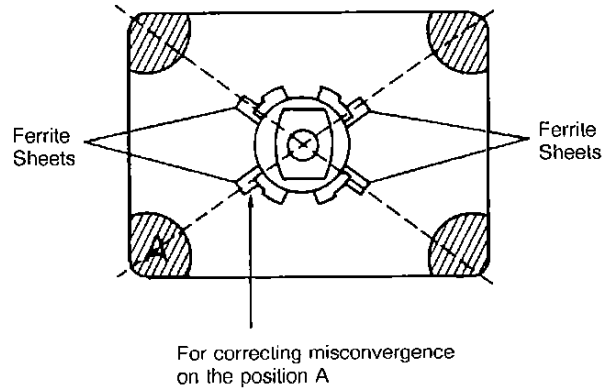

# SERVICE MODE GENERAL INSTRUCTION

## 1. ENTERING TO SERVICE MODE

1. Press MUTE button once on the Remote Control.
2. Press MUTE button again to keep pressing.
3. Keep pressing the MUTE button, press MENU button on the TV.  
The SERVICE MODE picture will appear on screen.

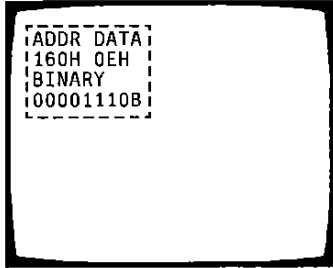

## 2. SWITCHING OF ADJUSTING MODE

The main address will change as shown below by every pressing of MENU button on the TV.

160H→107H→100H→174H→1D0H→120H→[Exit from SERVICE MODE]

ADDR	Name of ADJUSTING MODE	Last memory after adjustment
160H	Adjustment of video correction value	Memorize
107H	Sub adjustment	Memorize
100H	Adjustment of IC501 (VIDEO processing)	Memorize except for a part.
174H	Setting of the optional functions	Memorize
1D0H	Change of in non volatile memory data	Memorize
120H	Adjustment of deflection IC	Memorize

## 3. SWITCHING METHOD OF ADJUSTMENT ITEMS IN THE ADJUSTING MODE

Every pressing of VOLUME ▲ button will change the address as below, and the pressing of VOLUME ▼ button will change the address to the reverse direction.

1. 160H →162H→164H→165H→160H (returned to start position)
2. 107H →108H→105H→163H→161H→111H→107H (to start position)
3. 100H →101H→102H→103H→104H→105H→106H→107H→108H→109H→10AH→10BH→10CH→10DH  
→10EH→10FH→110H→111H→112H→100H (to start position)
4. 174H →175H→176H→174H (to start position)
5. 1D0H→1D1H→1D2H→1D3H→1D4H→1D5H→1DAH→1DBH→1DCH→1DDH→1DEH→1DFH→1E0H  
→1E1H→1E2H→1D0H (to start position)
6. 120H →121H→122H→123H→124H→125H→126H→127H→128H→129H→12AH→120H (to start position)

#### 4. ADJUSTMENT METHOD OF DATA

- Pressing of + or - button will change the value of DATA in the range from 00H to FFH.  
The variable range depends on the adjusting item.

#### 5. EXIT FROM SERVICE MODE

Pressing any of the following buttons releases the SERVICE mode.

- EXIT
- POWER
- MENU key
- Other keys associated with display

#### 6. OTHER SERVICE FUNCTIONS

The following key entry during display of service mode screen, provides special functions.

- MUTE : Presetting of all channels (delivery setting)
- ANT/VIDEO/ADV : A single horizontal line on screen
- RESET/EXIT : Execution of self diagnosis

#### 7. REFERENCE TABLE OF ADDRESS AND ADJUSTING ITEMS

ADDR	Adjusting Items	Reference Value (DATA)
< SUB ADJUSTMENT >		
☆107H	<b>Sub-Color</b>	90H
☆108H	Sub-Contrast	E7H
☆105H	PIP Brightness	60H
163H	Sub-Tint	52H
161H	<b>Sub-Bright</b>	5DH
< ADJUSTMENT OF IC501 >		
☆105H	PIP Brightness	60H
☆107H	Sub-Color	90H
☆108H	Sub-Contrast	E7H
109H	<b>R Cut-off</b>	40H
10AH	<b>G Cut-off</b>	40H
10BH	<b>B Cut-off</b>	40H
10CH	<b>G Drive</b>	40H
10DH	<b>B Drive</b>	40H
111H	<b>Hor. Picture Position</b>	6DH
112H	Ver. Picture Position	23H
< ADJUSTMENT OF DEF. IC >		
120H	<b>Ver. Height</b>	2BH
121H	Ver. Balance of Top & Bottom	*19H
122H	Ver. S-curve Correction	*03H
123H	Ver. Picture Position (Center point voltage)	*14H
124H	Ver. (Correction gain)	*07H
125H	<b>Hor. Width</b>	23H
126H	DPC/Pincushion	26H
127H	Pincushion (Hor. corner)	*02H
128H	Pincushion (Trapezoid)	*07H
129H	Hor. (Correction gain)	*07H
12AH	Pincushion (Ver. corner S-curve)	*0AH

#### NOTE:

- Usually, use the left data for the \* marks. Other data are different by models.
- ADDR with ☆ marks have the same numbers, but the same ADDR has the same contents.
- Adjusting items expressed bold font may require the adjustment when replacing ICA02 or IC501.

## 8. SELF DIAGNOSTIC FUNCTION

1. Press RESET button on the TV during display of SERVICE MODE picture, the diagnosis will begin to check if interface among IC's are executed properly.
2. During diagnosis, the following displays are shown.
  - (1) Operation number of protecting circuit  
(OVER CURRENT, OVER VOLTAGE, F/S) . . . . . The first position; "000" is normal.
  - (2) The status of SYNC signal at pin 29 of ICA01 . . . . . The second position; "OK" is normal.
  - (3) Communication status to IC's  
(H001, H002, ICA02, IC501, ICV01 and ICN06)

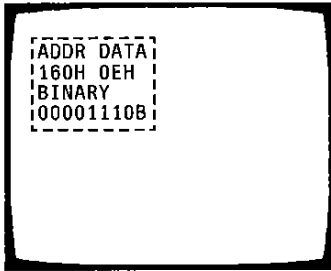

Example of display of service mode



Press RESET button on TV set.

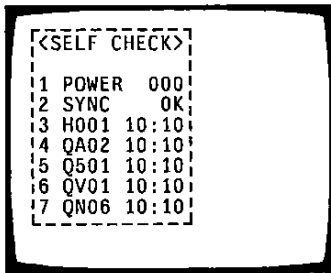

- (4) Nos 3 to 8 on the screen display which are connected to #31 and #32 (SCL, SDA) line, show number of controls carried out correctly and the number of confirmation.  
(Number of confirmation) : (Number of correct control)

└─> 10 is normal.  
Less than 10 means defective IC.

## SERVICE MODE ADJUSTMENT

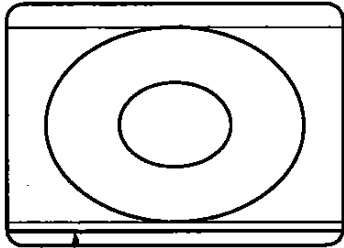
ITEM	ADJUSTMENT PROCEDURE
INITIALIZATION OF ICA02 (MEMORY)	<p>After replacing ICA02, adjustment in SERVICE MODE is required.</p> <ol style="list-style-type: none"> <li>1. Call up the SERVICE MODE display following the step 1 on page "21".</li> <li>2. Press the RECALL button on the Remote Control. The initialization of ICA02 has been completed.</li> <li>3. Check the picture carefully. If necessary, adjust any address.</li> </ol>
HORIZ. WIDTH ADJUSTMENT (ADDR : 125H)	<ol style="list-style-type: none"> <li>1. Call up the SERVICE MODE display.</li> <li>2. Press the MENU button on the TV to select the Main Address <b>120H</b>.</li> <li>3. Press the VOLUME ▲ or ▼ button to select the Sub-Address <b>125H</b>.</li> <li>4. Press the + or - button on Remote Control, to get picture so the left and right of raster begin to lack. Note: If the HORIZ. PICTURE POSITION is not proper, adjust the sub-address <b>111H</b> to set the picture to the center.</li> <li>5. Press the + button to advance the data by 8 steps.</li> </ol>
VER. HEIGHT ADJUSTMENT (ADDR : 120H)	<ol style="list-style-type: none"> <li>1. Call up the SERVICE MODE display, then select the Main Address <b>120H</b>.</li> <li>2. Press + or - button on Remote Control, to get picture so the top of raster begins to lack.</li> <li>3. Press + button to advance the data by 11 steps. (Note: Check the vertical picture position is correct.)</li> </ol>
SUB-BRIGHT ADJUSTMENT (ADDR : 161H)	<ol style="list-style-type: none"> <li>1. Set the CONTRAST control to the minimum.</li> <li>2. Call up the SERVICE MODE display, then select Main Address <b>107H</b>, Sub-Address <b>161H</b>.</li> <li>3. Press + or - button on Remote Control so the belt of vertical retrace line just disappear.</li> <li>4. Adjust the CONTRAST control for the desired contrast.</li> <li>5. Perform VER. HEIGHT ADJUSTMENT above.</li> </ol> <div style="text-align: right; margin-top: 10px;">  <p style="text-align: center;">Vertical retrace line</p> </div>
WHITE BALANCE ADJUSTMENT  R CUT-OFF (ADDR : 109H) G CUT-OFF (ADDR: 10AH) B CUT-OFF (ADDR: 10BH) G DRIVE (ADDR: 10CH) B DRIVE (ADDR: 10DH)	<ol style="list-style-type: none"> <li>1. Call up the SERVICE MODE display, then select Main Address <b>100H</b>, Sub-Address <b>109H</b>.</li> <li>2. Press VIDEO button on the TV, to get one horizontal line on the picture. When the horizontal line does not appear, rotate SCREEN control to show one horizontal line on picture center slightly. Note: Every pressing of VIDEO button provides a picture of horizontal line, or normal receiving picture alternately.</li> <li>3. Press + or - button to adjust Sub-Address <b>109H</b> (R CUT-OFF), <b>10AH</b> (G CUT-OFF) and <b>10BH</b> (B CUT-OFF), so that the three colors slightly light up with the same level.</li> <li>4. For the white balance of dark area, adjust Sub-Address of CUT-OFF. For the white balance of light area, adjust Sub-Address <b>10CH</b> (G DRIVE) and <b>10DH</b> (B DRIVE).</li> </ol>

# CIRCUIT ADJUSTMENT

## HIGH VOLTAGE CHECK

**CAUTION:** There is no HIGH VOLTAGE ADJUSTMENT on this chassis. Checking should be done following the steps below.

1. Connect an accurate high voltage meter to the second anode of the picture tube.
2. Turn on the receiver. Set the BRIGHT and CONTRAST Controls to minimum (zero beam current).
3. High voltage must be measured below 33.2 kV.
4. Rotate the BRIGHT Control to both extremes to be sure the high voltage does not exceed the limit under any conditions.

## FS CIRCUIT CHECK

The Fail Safe (FS) circuit check is indispensable for the final check in servicing. Checking should be done following the steps below.

1. Turn the receiver on and press the RESET button.
2. Temporarily short TP- ⓐ and TP- ⓑ with a jumper wire. Raster and sound will disappear.
3. The receiver must remain in this state even after removing the jumper wire. This is the evidence that the FS circuit is functioning properly.
4. To obtain a picture again, temporarily turn the receiver off and allow the FS circuit more than 5 seconds to reset. Then turn the power switch on to produce a normal picture.

## Troubleshooting Guide for Fail Safe Circuit

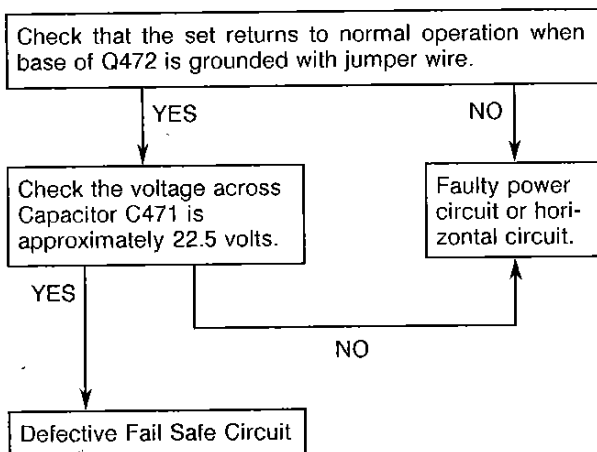

## FOCUS ADJUSTMENT

Adjust the FOCUS Control (on T461) for well defined scanning lines on the picture screen.

## PIP FRAME POSITION ADJUSTMENT

1. Receive the pattern signal which shows its center on the main screen.
2. Call up the PIP screen.
3. Adjust RY53 on the SIGNAL board to equalize the distance "a" to "b" as shown below.

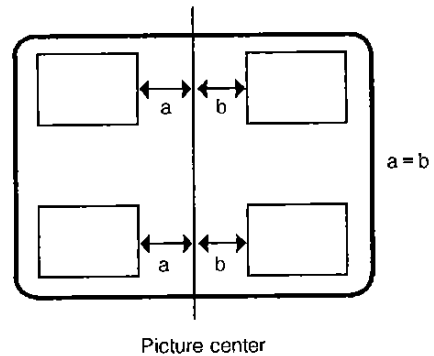

## PIP WHITE BALANCE ADJUSTMENT

1. Receive an active channel on the PIP screen.
2. Adjust 2 VR's on the PIP module alternately for proper white balance.

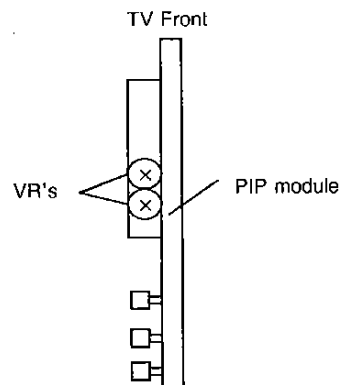



## PIN FUNCTION OF MICROPROCESSOR ICA01

Pin No.	Name	IN/OUT	IN/OUT Control Register		Function and Logic
1	X-RAY	IN	P4CR (0CH)	D0 = 0	Operational count in over-current protect circuit (Positive logic)
2	SYNC3	IN		D1 = 0	
3	CS	OUT		D2 = 1	OSD CS control (Negative logic)
4	STB	OUT		D3 = 1	Seri-Para STROBE (Positive logic)
5	T-PRD	OUT		D4 = 1	T-BUS period (Negative logic)
6	T-CLK	OUT		D5 = 1	T-BUS clock, Rising period
7	T-DATA	IN/OUT		D6 = 0/1	T-BUS data
8	I <sup>2</sup> C STOP	IN		D7 = 0	I <sup>2</sup> C-BUS stop (Negative logic)
9	AFT1	IN	P5 (05H)	D0 = 1	PWM8 AFT S-curve det., In receiving
10	AFT2	IN		D1 = 1	PWM9 PIP S-curve det., In receiving
11	ACP	IN	TC2CR 15H	D2 = 1	AC pulse count, Pulse with 16.6ms period
12	SYNC2	IN	TC1CR 14H	D3 = 1	PIP sync judge (Positive logic)
13	KEY1	IN	P5CR (028H)	D4 = 0	Local key input, 0 to 5V
14	KEY2	IN		D5 = 0	Local key input, 0 to 5V
15	MODE	IN		D6 = 0	Option judge, 0 to 5V
16	LED	IN		D7 = 0	Broadcast mode judge
17	Yin	IN	P6CR (0DH)	D0 = 0	
18	Bin	IN		D1 = 0	
19	Gin	IN		D2 = 0	
20	Rin	IN		D3 = 0	
21	GND	—	—	—	Ground, 0V connection
22	R	OUT	P6CR (0DH)	D4 = 1	
23	G	OUT		D5 = 1	
24	B	OUT		D6 = 1	
25	Y	OUT		D7 = 1	
26	HD	IN	P7 (07H)	D0 = 1	HOR sync pulse det. (Negative logic)
27	VD	IN		D1 = 1	VER sync pulse det. (Negative logic)
28	OSCI	IN		D2 = 1	PLL · OSD osc. circuit, Ext. LC connection PLLCR2 (0FA9H) PSEL: 1, PLLS: 0
29	OSCO	OUT		D3 = 0	
30	TEST	IN	—	—	For factory test, Open
31	XIN	IN	—	—	Oscillation for system clock (8MHz)
32	XOUT	OUT	—	—	
33	RESET	IN	—	—	Negative logic
34	ITN21H	IN	P2 (02H)	D0 = 1	
35	RMT	IN	P3 (03H)	D0 = 1	Remote signal det. (Negative logic)
36	SYNC1	IN		D1 = 1	Sync pulse input (Negative logic)
37	SCL	OUT		D4 = 1	I <sup>2</sup> C-BUS clock, Rising sync
38	SDA	IN/OUT		D5 = 1	I <sup>2</sup> C-BUS clock
39	VVSS	—	—	—	Ground, 0V connection
40	CSIN	IN			Port for CAPTION circuit
41	CIN0	IN			
42	VDD	IN	—	—	Power supply, 5V

# CABINET REPLACEMENT PARTS LIST

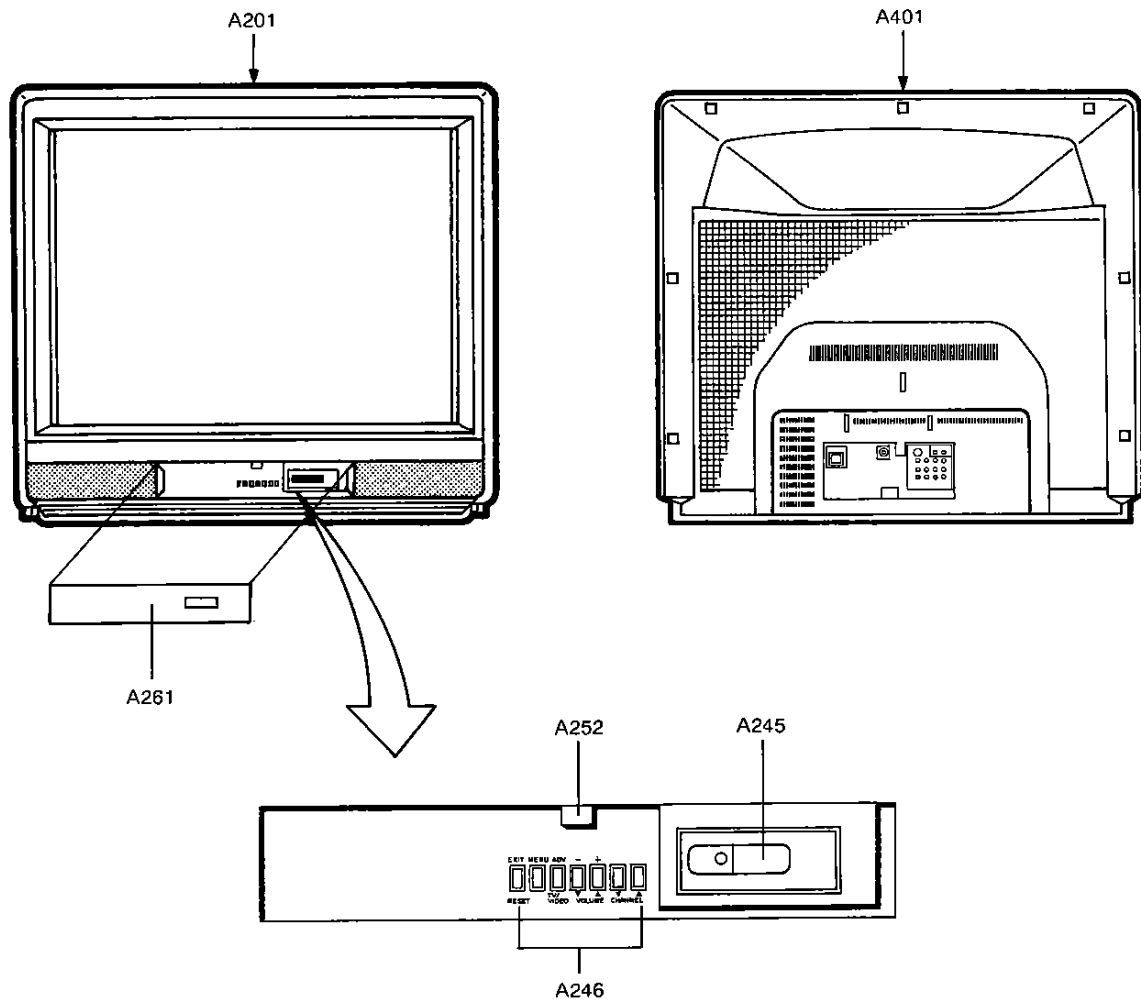

**CF35D50 : TV35D50**

Location No.	Part No.	Description
A201	23410342	Front Cover
A245	23443707	Button, POWER
A246	23443696	Button, 7-key
A248	70393022	Nut
A252	23451204	Push-Catch
A261	23425217	Door
A401	23426018	Back Cover



## CHASSIS REPLACEMENT PARTS LIST

**WARNING:** BEFORE SERVICING THIS CHASSIS, READ THE "X-RAY RADIATION PRECAUTION", "SAFETY PRECAUTION" AND "PRODUCT SAFETY NOTICE" ON PAGE 2 OF THIS MANUAL.

**CAUTION:** The international hazard symbols "  $\Delta$  " in the schematic diagram and the parts list designate components which have special characteristics important for safety and should be replaced only with types identical to those in the original circuit or specified in the parts list. The mounting position of replacements is to be identical with originals. Before replacing any of these components, read carefully the PRODUCT SAFETY NOTICE on page 2. Do not degrade the safety of the receiver through improper servicing.

**NOTICE:** The part number must be used when ordering parts, in order to assist in processing, be sure to include the Model number and Description.

**ABBREVIATIONS:**

Capacitors.....	CD : Ceramic Disk	PF : Plastic Film	EL : Electrolytic
Resistors.....	CF : Carbon Film	CC : Carbon Composition	MF : Metal Film
	OMF : Oxide Metal Film	VR : Variable Resistor	FR : Fusible Resistor

(All CD and PF capacitors are  $\pm 5\%$ , 50V and all resistors,  $\pm 5\%$ , 1/6W unless otherwise noted.)

### Model CF35D50 : TV35D50

Location No.	Part No.	Description
<b>CAPACITORS</b>		
C060	24763471	EL, 470 $\mu$ F, $\pm 20\%$ , 16V
C061	24794470	EL, 47 $\mu$ F, $\pm 20\%$ , 16V
C062	24763101	EL, 100 $\mu$ F, $\pm 20\%$ , 16V
C063	24796479	EL, 4.7 $\mu$ F, $\pm 20\%$ , 35V
C064	24766330	EL, 33 $\mu$ F, $\pm 20\%$ , 50V
C071	24476103	CD, 0.01 $\mu$ F, $\pm 30\%$ , 16V
C072	24232103	CD, 0.01 $\mu$ F, +80%, -20%
C180	24085961	EL, 10 $\mu$ F, $\pm 20\%$ , 50V, Non-Polar
C203	24206229	EL, 2.2 $\mu$ F, 50V
C206	24473220	CD, 22pF
C212	24206229	EL, 2.2 $\mu$ F, 50V
C220	24474101	CD, 100pF, $\pm 10\%$
C221	24539104	PF, 0.1 $\mu$ F
C222	24539104	PF, 0.1 $\mu$ F
C223	24539104	PF, 0.1 $\mu$ F
C224	24206478	EL, 0.47 $\mu$ F, 50V
C225	24763221	EL, 220 $\mu$ F, $\pm 20\%$ , 16V
C226	24763471	EL, 470 $\mu$ F, $\pm 20\%$ , 16V
C228	24473560	CD, 56pF
C230	24591152	PF, 1500pF
C240	24473270	CD, 27pF
C241	24436120	CD, 12pF
C242	24436220	CD, 22pF
C263	24232103	CD, 0.01 $\mu$ F, +80%, -20%
C264	24539104	PF, 0.1 $\mu$ F
C265	24763221	EL, 220 $\mu$ F, $\pm 20\%$ , 16V
C266	24539104	PF, 0.1 $\mu$ F
C267	24232103	CD, 0.01 $\mu$ F, +80%, -20%
C268	24794102	EL, 1000 $\mu$ F, $\pm 20\%$ , 16V
C270	24206229	EL, 2.2 $\mu$ F, 50V
C271	24796479	EL, 4.7 $\mu$ F, $\pm 20\%$ , 35V
C272	24203100	EL, 10 $\mu$ F, $\pm 20\%$ , 16V
C273	24206228	EL, 0.22 $\mu$ F, 50V
C274	24206228	EL, 0.22 $\mu$ F, 50V
C277	24539104	PF, 0.1 $\mu$ F
C280	24763101	EL, 100 $\mu$ F, $\pm 20\%$ , 16V
C281	24669010	EL, 1 $\mu$ F, $\pm 20\%$ , 50V
C282	24669010	EL, 1 $\mu$ F, $\pm 20\%$ , 50V
C303	24214471	CD, 470pF, $\pm 10\%$ , 500V

Location No.	Part No.	Description
C305	24617915	EL, 1 $\mu$ F, $\pm 10\%$ , 50V
C306	24630798	EL, 3300 $\mu$ F, $\pm 10\%$ , 25V
C307	24693473	PF, 0.047 $\mu$ F, 100V
C308	24668221	EL, 220 $\mu$ F, $\pm 20\%$ , 35V
C310	24765222	EL, 2200 $\mu$ F, $\pm 20\%$ , 35V
C311	24214561	CD, 560pF, $\pm 10\%$ , 500V
C312	24591102	PF, 1000pF
C313	24082053	PF, 0.1 $\mu$ F, 100V
C314	24591563	PF, 0.056 $\mu$ F
C315	24539104	PF, 0.1 $\mu$ F
C317	24617926	EL, 220 $\mu$ F, $\pm 20\%$ , 16V
C318	24666101	EL, 100 $\mu$ F, $\pm 20\%$ , 16V
C319	24212102	CD, 1000pF, $\pm 10\%$
C320	24668101	EL, 100 $\mu$ F, $\pm 20\%$ , 35V
C321	24591203	PF, 0.02 $\mu$ F
C322	24617912	EL, 2.2 $\mu$ F, $\pm 10\%$ , 50V
C323	24539224	PF, 0.22 $\mu$ F
C324	24666101	EL, 100 $\mu$ F, $\pm 20\%$ , 16V
C326	24591683	PF, 0.068 $\mu$ F
C344	24206229	EL, 2.2 $\mu$ F, 50V
C388	24666101	EL, 100 $\mu$ F, $\pm 20\%$ , 16V
C389	24679100	EL, 10 $\mu$ F, $\pm 20\%$ , 250V
C401	24763101	EL, 100 $\mu$ F, $\pm 20\%$ , 16V
C402	24232103	CD, 0.01 $\mu$ F, +80%, -20%
C403	24763101	EL, 100 $\mu$ F, $\pm 20\%$ , 16V
C409	24232102	CD, 1000pF, +80%, -20%
C412	24591123	PF, 0.012 $\mu$ F
C413(U801)	24214821	CD, 820pF, $\pm 10\%$ , 500V
C413(U902)	24591392	PF, 3900pF
C414	24206010	EL, 1 $\mu$ F, 50V
C416	24677100	EL, 10 $\mu$ F, $\pm 20\%$ , 160V
C417	24214391	CD, 390pF, $\pm 10\%$ , 500V
C418	24591183	PF, 0.018 $\mu$ F
C420	24763101	EL, 100 $\mu$ F, $\pm 20\%$ , 16V
C421	24539104	PF, 0.1 $\mu$ F
C423	24436121	CD, 120pF
$\Delta$ C440	24082250	PF, 7800pF, 1500V
$\Delta$ C442	24095791	PF, 0.2 $\mu$ F, 400V
$\Delta$ C443	24095791	PF, 0.2 $\mu$ F, 400V
$\Delta$ C444	24082288	PF, 5600pF, $\pm 3\%$ , 1800V
C445	24828473	PF, 0.047 $\mu$ F, 200V

Location No.	Part No.	Description
C446	24829433	PF, 0.043 $\mu$ F, 400V
C447	24679330	EL, 33 $\mu$ F, $\pm$ 20%, 250V
C448	24640908	EL, 33 $\mu$ F, $\pm$ 20%, 160V
C463	24212152	CD, 1500pF, $\pm$ 10%
C471	24206479	EL, 4.7 $\mu$ F, 50V
C474	24203100	EL, 10 $\mu$ F, $\pm$ 20%, 16V
C475	24095887	PF, 0.01 $\mu$ F, $\pm$ 3%, 630V
C480	24747478	EL, 0.47 $\mu$ F, $\pm$ 20%, 50V
C498	24539104	PF, 0.1 $\mu$ F
C501	24591333	PF, 0.033 $\mu$ F
C502	24591333	PF, 0.033 $\mu$ F
C507	24473010	CD, 1 $\mu$ F, $\pm$ 20%, 50V
C508	24591472	PF, 4700pF
C509	24472120	CD, 12pF
C510	24206229	EL, 2.2 $\mu$ F, 50V
C514	24591333	PF, 0.033 $\mu$ F
C638	24797479	EL, 4.7 $\mu$ F, $\pm$ 20%, 50V
C639	24797479	EL, 4.7 $\mu$ F, $\pm$ 20%, 50V
C640	24667470	EL, 47 $\mu$ F, $\pm$ 20%, 25V
C641	24669010	EL, 1 $\mu$ F, $\pm$ 20%, 50V
C642	24591102	PF, 1000pF
C645	24591102	PF, 1000pF
C647	24669010	EL, 1 $\mu$ F, $\pm$ 20%, 50V
C649	24667470	EL, 47 $\mu$ F, $\pm$ 20%, 25V
C650	24667470	EL, 47 $\mu$ F, $\pm$ 20%, 25V
C651	24668101	EL, 100 $\mu$ F, $\pm$ 20%, 35V
C652	24668471	EL, 470 $\mu$ F, $\pm$ 20%, 35V
C654	24539124	PF, 0.12 $\mu$ F
C658	24668471	EL, 470 $\mu$ F, $\pm$ 20%, 35V
C659	24539124	PF, 0.12 $\mu$ F
C660	24232103	CD, 0.01 $\mu$ F, +80%, -20%
C661	24232103	CD, 0.01 $\mu$ F, +80%, -20%
C701	24203470	EL, 47 $\mu$ F, $\pm$ 20%, 16V
C702	24203101	EL, 100 $\mu$ F, $\pm$ 20%, 16V
C703	24436820	CD, 82pF
C704	24591822	PF, 8200pF
C705	24212103	CD, 0.01 $\mu$ F, $\pm$ 10%
C707	24794470	EL, 47 $\mu$ F, $\pm$ 20%, 16V
C708	24212103	CD, 0.01 $\mu$ F, $\pm$ 10%
C710	24203100	EL, 10 $\mu$ F, $\pm$ 20%, 16V
C712	24666470	EL, 47 $\mu$ F, $\pm$ 20%, 16V
C713	24790100	EL, 10 $\mu$ F, $\pm$ 20%, 160V
C714	24436101	CD, 100pF
C715	24214472	CD, 4700pF, $\pm$ 10%, 500V
C716	24436101	CD, 100pF
C717	24214472	CD, 4700pF, $\pm$ 10%, 500V
C718	24790470	EL, 47 $\mu$ F, $\pm$ 20%, 160V
C719	24435560	CD, 56pF, 500V
C720	24790100	EL, 10 $\mu$ F, $\pm$ 20%, 160V
C721	24790470	EL, 47 $\mu$ F, $\pm$ 20%, 160V
C722	24436561	CD, 560pF
C723	24212102	CD, 1000pF, $\pm$ 10%
C724	24436121	CD, 120pF
C725	24436101	CD, 100pF
C726	24212102	CD, 1000pF, $\pm$ 10%
△C802	24092300	CD, 0.01 $\mu$ F, +80%, -20%, AC250V
△C803	24092300	CD, 0.01 $\mu$ F, +80%, -20%, AC250V
△C804	24082001	PF, 0.47 $\mu$ F, $\pm$ 20%, AC125V
C807	24539474	PF, 0.47 $\mu$ F
C810	24086932	EL, 1000 $\mu$ F, $\pm$ 20%, 200V
△C811	24092270	CD, 4700pF, $\pm$ 20%, AC400V
△C812	24092270	CD, 4700pF, $\pm$ 20%, AC400V

Location No.	Part No.	Description
△C813	24092270	CD, 4700pF, $\pm$ 20%, AC400V
△C814	24092270	CD, 4700pF, $\pm$ 20%, AC400V
C840	24667102	EL, 1000 $\mu$ F, $\pm$ 20%, 25V
C842	24082229	PF, 0.1 $\mu$ F, $\pm$ 10%, 250V
C843	24539104	PF, 0.1 $\mu$ F
C844	24761102	EL, 1000 $\mu$ F, $\pm$ 20%, 6.3V
C858	24212222	CD, 2200pF, $\pm$ 10%
C860	24591102	PF, 1000pF
C861	24214331	CD, 330pF, $\pm$ 10%, 500V
C862	24214331	CD, 330pF, $\pm$ 10%, 500V
C863	24640956	EL, 47 $\mu$ F, $\pm$ 20%, 100V
C864	24092335	CD, 15pF, $\pm$ 10%, 2kV
C865	24092347	CD, 1500pF, $\pm$ 10%, 2kV
C866	24092347	CD, 1500pF, $\pm$ 10%, 2kV
C867	24539104	PF, 0.1 $\mu$ F
C868	24214331	CD, 330pF, $\pm$ 10%, 500V
C869	24591102	PF, 1000pF
C870	24206010	EL, 1 $\mu$ F, 50V
C871	24669220	EL, 22 $\mu$ F, $\pm$ 20%, 50V
C872	24212471	CD, 470pF, $\pm$ 10%
C873	24212101	CD, 100pF, $\pm$ 10%
C881	24092341	CD, 470pF, $\pm$ 10%, 2kV
C882	24092341	CD, 470pF, $\pm$ 10%, 2kV
C883	24214821	CD, 820pF, $\pm$ 10%, 500V
C884	24086917	EL, 470 $\mu$ F, $\pm$ 20%, 160V
C885	24214821	CD, 820pF, $\pm$ 10%, 500V
C886	24214331	CD, 330pF, $\pm$ 10%, 500V
C887	24214331	CD, 330pF, $\pm$ 10%, 500V
C888	24092337	CD, 220pF, $\pm$ 10%, 2kV
C889	24668332	EL, 3300 $\mu$ F, $\pm$ 20%, 35V
C890	24092338	CD, 270pF, $\pm$ 10%, 2kV
C891	24667332	EL, 3300 $\mu$ F, $\pm$ 20%, 25V
C892	24677101	EL, 100 $\mu$ F, $\pm$ 20%, 160V
C894	24591473	PF, 0.047 $\mu$ F
C895	24212222	CD, 2200pF, $\pm$ 10%
C902	24092353	CD, 4700pF, $\pm$ 10%, 2kV
C904	24436391	CD, 390pF
C905	24436391	CD, 390pF
C907	24436391	CD, 390pF
C909	24679220	EL, 22 $\mu$ F, $\pm$ 20%, 250V
C910	24797478	EL, 0.47 $\mu$ F, $\pm$ 20%, 50V
C911	24203100	EL, 10 $\mu$ F, $\pm$ 20%, 16V
C912	24763471	EL, 470 $\mu$ F, $\pm$ 20%, 16V
C913	24203100	EL, 10 $\mu$ F, $\pm$ 20%, 16V
C914	24212103	CD, 0.01 $\mu$ F, $\pm$ 10%
C930	24214101	CD, 100pF, $\pm$ 10%, 500V
C931	24214101	CD, 100pF, $\pm$ 10%, 500V
CA11	24476103	CD, 0.01 $\mu$ F, $\pm$ 30%, 16V
CA19	24539104	PF, 0.1 $\mu$ F
CA20	24539104	PF, 0.1 $\mu$ F
CA21	24436101	CD, 100pF
CA22	24794100	EL, 10 $\mu$ F, $\pm$ 20%, 16V
CA23	24203100	EL, 10 $\mu$ F, $\pm$ 20%, 16V
CA26	24203100	EL, 10 $\mu$ F, $\pm$ 20%, 16V
CA30	24474101	CD, 100pF, $\pm$ 10%
CA33	24476103	CD, 0.01 $\mu$ F, $\pm$ 30%, 16V
CA34	24232103	CD, 0.01 $\mu$ F, +80%, -20%
CA42	24476103	CD, 0.01 $\mu$ F, $\pm$ 30%, 16V
CA43	24766471	EL, 470 $\mu$ F, $\pm$ 20%, 50V
CA65	24666100	EL, 10 $\mu$ F, $\pm$ 20%, 16V
CA113	24473330	CD, 33pF
CA315	24474121	CD, 120pF, $\pm$ 10%
CB57	24206229	EL, 2.2 $\mu$ F, 50V
CB58	24590102	PF, 1000pF

Location No.	Part No.	Description
CB59	24436561	CD, 560pF
CB60	24591132	PF, 1300pF
CB61	24203100	EL, 10 $\mu$ F, $\pm$ 20%, 16V
CBB41	24206229	EL, 2.2 $\mu$ F, 50V
CBB42	24590102	PF, 1000pF
CBB43	24436561	CD, 560pF
CBB45	24591132	PF, 1300pF
CD01	24668101	EL, 100 $\mu$ F, $\pm$ 20%, 35V
$\Delta$ CD02	24095883	PF, 0.015 $\mu$ F, 630V
CD03	24206478	EL, 0.47 $\mu$ F, 50V
CD11	24640872	EL, 10 $\mu$ F, $\pm$ 20%, 100V
CD17	24095787	PF, 0.3 $\mu$ F, 400V
CF02	24666101	EL, 100 $\mu$ F, $\pm$ 20%, 16V
CF04	24666101	EL, 100 $\mu$ F, $\pm$ 20%, 16V
CF05	24666101	EL, 100 $\mu$ F, $\pm$ 20%, 16V
CF06	24666101	EL, 100 $\mu$ F, $\pm$ 20%, 16V
CF07	24667101	EL, 100 $\mu$ F, $\pm$ 20%, 25V
CF08	24667101	EL, 100 $\mu$ F, $\pm$ 20%, 25V
CF09	24667101	EL, 100 $\mu$ F, $\pm$ 20%, 25V
CF23	24666101	EL, 100 $\mu$ F, $\pm$ 20%, 16V
CG33	24206229	EL, 2.2 $\mu$ F, 50V
CG34	24206229	EL, 2.2 $\mu$ F, 50V
CM01	24092017	CD, 0.1 $\mu$ F, +80%, -20%, 12V
CM04	24085970	EL, 10 $\mu$ F, $\pm$ 20%, 16V, Non-Polar
CM05	24436301	CD, 300pF
CM65	24591102	PF, 1000pF
CM66	24539104	PF, 0.1 $\mu$ F
CM68	24232103	CD, 0.01 $\mu$ F, +80%, -20%
CM89	24203101	EL, 100 $\mu$ F, $\pm$ 20%, 16V
CM71	24539104	PF, 0.1 $\mu$ F
CM72	24206010	EL, 1 $\mu$ F, 50V
CM73	24538103	PF, 0.01 $\mu$ F
CM74	24669010	EL, 1 $\mu$ F, $\pm$ 20%, 50V
CN15	24666221	EL, 220 $\mu$ F, $\pm$ 20%, 16V
CN50	24206010	EL, 1 $\mu$ F, 50V
CN51	24203100	EL, 10 $\mu$ F, $\pm$ 20%, 16V
CN52	24203100	EL, 10 $\mu$ F, $\pm$ 20%, 16V
CN53	24206010	EL, 1 $\mu$ F, 50V
CN96	24666220	EL, 22 $\mu$ F, $\pm$ 20%, 16V
CS03	24436391	CD, 390pF
CS04	24206010	EL, 1 $\mu$ F, 50V
CS05	24203100	EL, 10 $\mu$ F, $\pm$ 20%, 16V
CS06	24203100	EL, 10 $\mu$ F, $\pm$ 20%, 16V
CS07	24436391	CD, 390pF
CS08	24206010	EL, 1 $\mu$ F, 50V
CS09	24436391	CD, 390pF
CS10	24206229	EL, 2.2 $\mu$ F, 50V
CS11	24436391	CD, 390pF
CS12	24206229	EL, 2.2 $\mu$ F, 50V
CS13	24436391	CD, 390pF
CS14	24436391	CD, 390pF
CS15	24436391	CD, 390pF
CS16	24206229	EL, 2.2 $\mu$ F, 50V
CS17	24436391	CD, 390pF
CS23	24203100	EL, 10 $\mu$ F, $\pm$ 20%, 16V
CS24	24203100	EL, 10 $\mu$ F, $\pm$ 20%, 16V
CS30	24206229	EL, 2.2 $\mu$ F, 50V
CS31	24206229	EL, 2.2 $\mu$ F, 50V
CS32	24206229	EL, 2.2 $\mu$ F, 50V
CV01	24763101	EL, 100 $\mu$ F, $\pm$ 20%, 16V
CV02	24203470	EL, 47 $\mu$ F, $\pm$ 20%, 16V
CV03	24085939	EL, 4.7 $\mu$ F, $\pm$ 20%, 25V, Non-Polar

Location No.	Part No.	Description
CV04	24203100	EL, 10 $\mu$ F, $\pm$ 20%, 16V
CV05	24203100	EL, 10 $\mu$ F, $\pm$ 20%, 16V
CV06	24203100	EL, 10 $\mu$ F, $\pm$ 20%, 16V
CV08	24762102	EL, 1000 $\mu$ F, $\pm$ 20%, 10V
CV09	24203100	EL, 10 $\mu$ F, $\pm$ 20%, 16V
CV11	24232103	CD, 0.01 $\mu$ F, +80%, -20%
CV13	24232103	CD, 0.01 $\mu$ F, +80%, -20%
CV14	24232103	CD, 0.01 $\mu$ F, +80%, -20%
CV16	24203100	EL, 10 $\mu$ F, $\pm$ 20%, 16V
CV18	24763471	EL, 470 $\mu$ F, $\pm$ 20%, 16V
CV20	24436151	CD, 150pF
CV21	24436330	CD, 33pF
CV22	24203470	EL, 47 $\mu$ F, $\pm$ 20%, 16V
CV26	24763471	EL, 470 $\mu$ F, $\pm$ 20%, 16V
CV41	24212102	CD, 1000pF, $\pm$ 10%
CV60	24203470	EL, 47 $\mu$ F, $\pm$ 20%, 16V
CV61	24232103	CD, 0.01 $\mu$ F, +80%, -20%
CV70	24762102	EL, 1000 $\mu$ F, $\pm$ 20%, 10V
CY02	24591272	PF, 2700pF
CZ01	24436330	CD, 33pF
CZ02	24436101	CD, 100pF
CZ03	24538103	PF, 0.01 $\mu$ F
CZ04	24591472	PF, 4700pF
CZ05	24232103	CD, 0.01 $\mu$ F, +80%, -20%
CZ06	24206478	EL, 0.47 $\mu$ F, 50V
CZ07	24203100	EL, 10 $\mu$ F, $\pm$ 20%, 16V
CZ08	24206479	EL, 4.7 $\mu$ F, 50V
CZ09	24203100	EL, 10 $\mu$ F, $\pm$ 20%, 16V
CZ10	24206010	EL, 1 $\mu$ F, 50V
CZ11	24092017	CD, 0.1 $\mu$ F, +80%, -20%, 12V
CZ12	24436331	CD, 330pF
CZ13	24436220	CD, 22pF
CZ14	24092017	CD, 0.1 $\mu$ F, +80%, -20%, 12V
CZ17	24436121	CD, 120pF
CZ18	24436121	CD, 120pF
CZ19	24436221	CD, 220pF
CZ20	24436221	CD, 220pF
CZ21	24436560	CD, 56pF
CZ26	24203100	EL, 10 $\mu$ F, $\pm$ 20%, 16V
CZ28	24232103	CD, 0.01 $\mu$ F, +80%, -20%
CZ30	24092017	CD, 0.1 $\mu$ F, +80%, -20%, 12V
CZ31	24203220	EL, 22 $\mu$ F, $\pm$ 20%, 16V
CZ32	24092017	CD, 0.1 $\mu$ F, +80%, -20%, 12V
CZ33	24591104	PF, 0.1 $\mu$ F
CZ34	24092017	CD, 0.1 $\mu$ F, +80%, -20%, 12V
<b>RESISTORS</b>		
R060	24366101	CF, 100 ohm
R061	24366101	CF, 100 ohm
R201	24366102	CF, 1k ohm
R202	24366102	CF, 1k ohm
R203	24366102	CF, 1k ohm
R204	24366332	CF, 3300 ohm
R205	24366821	CF, 820 ohm
R206	24366472	CF, 4700 ohm
R207	24366821	CF, 820 ohm
R210	24366332	CF, 3300 ohm
R211	24366332	CF, 3300 ohm
R212	24366101	CF, 100 ohm
R213	24366334	CF, 330k ohm
R214	24366753	CF, 75k ohm
R215	24366103	CF, 10k ohm
R217	24366122	CF, 1200 ohm
R218	24367513	CF, 51k ohm, $\pm$ 2%

Location No.	Part No.	Description
R220	24366392	CF, 3900 ohm
R221	24366101	CF, 100 ohm
R222	24366101	CF, 100 ohm
R223	24366101	CF, 100 ohm
R224	24366102	CF, 1k ohm
R225	24366333	CF, 33k ohm
R226	24366184	CF, 180k ohm
R227	24367183	CF, 18k ohm, ±2%
R228	24366432	CF, 4300 ohm
R229	24366102	CF, 1k ohm
R232	24366221	CF, 220 ohm
R236	24366102	CF, 1k ohm
R237	24366682	CF, 6800 ohm
R241	24366272	CF, 2700 ohm
R242	24366223	CF, 22k ohm
R247	24366561	CF, 560 ohm
R263	24366223	CF, 22k ohm
R267	24366153	CF, 15k ohm
R268	24366184	CF, 180k ohm
R269	24366562	CF, 5600 ohm
R270	24366184	CF, 180k ohm
R271	24366513	CF, 51k ohm
R273	24366115	CF, 1.1M ohm
R274	24366514	CF, 510k ohm
R276	24366221	CF, 220 ohm
R277	24366221	CF, 220 ohm
R278	24366221	CF, 220 ohm
R279	24366105	CF, 1M ohm
R287	24366683	CF, 68k ohm
R288	24366154	CF, 150k ohm
R290	24366223	CF, 22k ohm
R303	24366823	CF, 82k ohm
R304	24366273	CF, 27k ohm
R305	24322758	OMF, 0.75 ohm, 1W
R306	24366623	CF, 62k ohm
R307	24366474	CF, 470k ohm
R308	24366102	CF, 1k ohm
R309	24382221	OMF, 220 ohm, 1W
R312	24552302	OMF, 3k ohm, 1/2W
R313	24366104	CF, 100k ohm
R314	24366105	CF, 1M ohm
R315	24366824	CF, 820k ohm
R316	24366204	CF, 200k ohm
R317	24366102	CF, 1k ohm
R318	24366471	CF, 470 ohm
R319	24366471	CF, 470 ohm
R320	24366101	CF, 100 ohm
R321	24366102	CF, 1k ohm
R322	24366272	CF, 2700 ohm
R323	24321369	OMF, 3.6 ohm, 1/2W
R324	24552301	OMF, 300 ohm, 1/2W
R325	24366332	CF, 3300 ohm
R326	24552222	OMF, 2200 ohm, 1/2W
△ R327	24339569	OMF, 5.6 ohm, 2W
R329	24366203	CF, 20k ohm
△ R336	24383271	OMF, 270 ohm, 2W
R341	24366163	CF, 16k ohm
R342	24366562	CF, 5600 ohm
R386	24321109	OMF, 1 ohm, 1/2W
R387	24366562	CF, 5600 ohm
R388	24366682	CF, 6800 ohm
R389	24366102	CF, 1k ohm
R390	24366163	CF, 16k ohm
R391	24366102	CF, 1k ohm

Location No.	Part No.	Description
R397	24321129	OMF, 1.2 ohm, 1/2W
R398	24552102	OMF, 1k ohm, 1/2W
R401	24366391	CF, 390 ohm
R403	24552561	OMF, 560 ohm, 1/2W
R405	24381152	OMF, 1500 ohm, 1/2W
R407	24366103	CF, 10k ohm
R408	24366223	CF, 22k ohm
R409	24366133	CF, 13k ohm
R411	24366561	CF, 560 ohm
R412	24366562	CF, 5600 ohm
R413	24366151	CF, 150 ohm
R414	24366274	CF, 270k ohm
R415	24553242	OMF, 2400 ohm, 1W
△ R416	24510562	Cement, 5600 ohm, 5W
R417	24366683	CF, 68k ohm
R418	24382431	OMF, 430 ohm, 1W
R419	24382101	OMF, 100 ohm, 1W
R420	24382393	OMF, 39k ohm, 1W
R421	24366105	CF, 1M ohm
R422	24366100	CF, 10 ohm
R423	24366102	CF, 1k ohm
R424	24366272	CF, 2700 ohm
R425	24366432	CF, 4300 ohm
R431	24366103	CF, 10k ohm
R432	24366202	CF, 2k ohm
△ R441	24532102	FR, 1k ohm, 1W
R443	24310109	OMF, 1.0 ohm, 1/2W
R444	24338398	OMF, 0.39 ohm, 1W
R447	24553473	OMF, 47k ohm, 1W
R463	24366102	CF, 1k ohm
R464	24366274	CF, 270k ohm
△ R472	24552270	OMF, 27 ohm, 1/2W
R476	24366823	CF, 82k ohm
R477	24366243	CF, 24k ohm
△ R478	24327133	MF, 13k ohm, ±1%, 1/4W
R479	24376333	CF, 33k ohm, 1/2W
△ R480	24366333	CF, 33k ohm
△ R482	24327512	MF, 5100 ohm, ±1%, 1/4W
R485	24552152	OMF, 1500 ohm, 1/2W
R486	24552822	OMF, 8200 ohm, 1/2W
R490	24366182	CF, 1800 ohm
R492	24552103	OMF, 10k ohm, 1/2W
R493	24552103	OMF, 10k ohm, 1/2W
R499	24366682	CF, 6800 ohm
R502	24366102	CF, 1k ohm
R509	24366152	CF, 1500 ohm
R510	24366103	CF, 10k ohm
R514	24366475	CF, 4.7M ohm
R518	24366471	CF, 470 ohm
R519	24366471	CF, 470 ohm
R640	24366182	CF, 1800 ohm
R641	24366103	CF, 10k ohm
R646	24366103	CF, 10k ohm
R647	24366182	CF, 1800 ohm
R648	24366229	CF, 2.2 ohm
R660	24366229	CF, 2.2 ohm
R701	24366153	CF, 15k ohm
R702	24366222	CF, 2200 ohm
R703	24366271	CF, 270 ohm
R704	24366152	CF, 1500 ohm
R705	24366222	CF, 2200 ohm
R706	24366102	CF, 1k ohm
R708	24366102	CF, 1k ohm
R709	24366563	CF, 56k ohm

Location No.	Part No.	Description
R710	24366471	CF, 470 ohm
R711	24366331	CF, 330 ohm
R712	24366220	CF, 22 ohm
R713	24366393	CF, 39k ohm
R714	24552121	OMF, 120 ohm, 1/2W
R715	24366223	CF, 22k ohm
R716	24366273	CF, 27k ohm
R717	24366333	CF, 33k ohm
R718	24366222	CF, 2200 ohm
R719	24366392	CF, 3900 ohm
R720	24366392	CF, 3900 ohm
R721	24366102	CF, 1k ohm
R722	24552471	OMF, 470 ohm, 1/2W
R723	24366471	CF, 470 ohm
R724	24366470	CF, 47 ohm
R725	24366182	CF, 1800 ohm
R726	24366473	CF, 47k ohm
R727	24366273	CF, 27k ohm
R728	24366222	CF, 2200 ohm
R729	24366104	CF, 100k ohm
R730	24552100	OMF, 10 ohm, 1/2W
R731	24552331	OMF, 330 ohm, 1/2W
R732	24366820	CF, 82 ohm
R733	24366683	CF, 68k ohm
R734	24366820	CF, 82 ohm
R735	24366683	CF, 68k ohm
R736	24552510	OMF, 51 ohm, 1/2W
R737	24366152	CF, 1500 ohm
R738	24366123	CF, 12k ohm
R739	24366152	CF, 1500 ohm
R740	24552510	OMF, 51 ohm, 1/2W
R741	24321279	OMF, 2.7 ohm, 1/2W
R742	24321279	OMF, 2.7 ohm, 1/2W
△R743	24554221	OMF, 220 ohm, 2W
R744	24366122	CF, 1200 ohm
R745	24366122	CF, 1200 ohm
△R804	24002994	CC, 3.9M ohm, 1/2W
△R805	24002994	CC, 3.9M ohm, 1/2W
△R808	24000862	PTC Thermistor, 7 ohm, ±20%, 140V
△R810	24007483	Cement, 1.1 ohm, 20W
△R811	24007416	Cement, 82 ohm, 5W
R840	24552180	OMF, 18 ohm, 1/2W
R841	24366273	CF, 27k ohm
R842	24366153	CF, 15k ohm
R843	24366562	CF, 5600 ohm
R844	24366473	CF, 47k ohm
△R860	24004701	MF, 0.1 ohm, 2W
R861	24366561	CF, 560 ohm
R862	24552912	OMF, 9100 ohm, 1/2W
R863	24552912	OMF, 9100 ohm, 1/2W
R864	24552471	OMF, 470 ohm, 1/2W
R865	24366471	CF, 470 ohm
△R866	24004701	MF, 0.1 ohm, 2W
R867	24552471	OMF, 470 ohm, 1/2W
△R868	24383331	OMF, 330 ohm, 2W
R869	24366392	CF, 3900 ohm
R870	24327203	MF, 20k ohm, ±1%, 1/4W
R871	24327203	MF, 20k ohm, ±1%, 1/4W
R872	24381131	OMF, 130 ohm, 1/2W
R873	24381301	OMF, 300 ohm, 1/2W
R874	24366681	CF, 680 ohm
R875	24366102	CF, 1k ohm
△R876	24323518	OMF, 0.51 ohm, 2W

Location No.	Part No.	Description
R877	24366471	CF, 470 ohm
R878	24327133	MF, 13k ohm, ±1%, 1/4W
R879	24327123	MF, 12k ohm, ±1%, 1/4W
R880	24327912	MF, 9100 ohm, ±1%, 1/4W
R881	24366102	CF, 1k ohm
R882	24382113	OMF, 11k ohm, 1W
R883	24382113	OMF, 11k ohm, 1W
R884	24366242	CF, 2400 ohm
R885	24366103	CF, 10k ohm
R886	24366302	CF, 3k ohm
R887	24366102	CF, 1k ohm
△R888	24554331	OMF, 330 ohm, 2W
△R890	24554331	OMF, 330 ohm, 2W
R895	24366182	CF, 1800 ohm
△R899	24000902	Varistor, TNR15G271K
R901	24946561	CC, 560 ohm, ±10%, 1/2W
R902	24946561	CC, 560 ohm, ±10%, 1/2W
R903	24946561	CC, 560 ohm, ±10%, 1/2W
R904	24366103	CF, 10k ohm
R905	24366101	CF, 100 ohm
R906	24552121	OMF, 120 ohm, 1/2W
R909	24366222	CF, 2200 ohm
R912	24366471	CF, 470 ohm
R914	24366561	CF, 560 ohm
R915	24366101	CF, 100 ohm
R916	24366620	CF, 62 ohm
R917	24366471	CF, 470 ohm
R918	24366820	CF, 82 ohm
R919	24366471	CF, 470 ohm
△R920	24000940	FR, 2 ohm, 2W
R921	24366561	CF, 560 ohm
R922	24366101	CF, 100 ohm
R924	24366820	CF, 82 ohm
R925	24366471	CF, 470 ohm
R926	24366471	CF, 470 ohm
R928	24366561	CF, 560 ohm
R929	24366101	CF, 100 ohm
R930	24366820	CF, 82 ohm
R932	24366152	CF, 1500 ohm
R933	24366750	CF, 75 ohm
R934	24366391	CF, 390 ohm
R935	24366821	CF, 820 ohm
R936	24366750	CF, 75 ohm
R937	24366471	CF, 470 ohm
R942	24366392	CF, 3900 ohm
R943	24366392	CF, 3900 ohm
R944	24366392	CF, 3900 ohm
R945	24366620	CF, 62 ohm
R946	24366620	CF, 62 ohm
△R960	24383153	OMF, 15k ohm, 2W
△R961	24383153	OMF, 15k ohm, 2W
△R962	24383153	OMF, 15k ohm, 2W
△R963	24383153	OMF, 15k ohm, 2W
△R964	24383153	OMF, 15k ohm, 2W
△R965	24383153	OMF, 15k ohm, 2W
R977	24366122	CF, 1200 ohm
R980	24005012	MF, 15M ohm, 1/2W
R981	24366150	CF, 15 ohm
RA01	24366103	CF, 10k ohm
RA02	24366102	CF, 1k ohm
RA03	24366102	CF, 1k ohm
RA04	24366102	CF, 1k ohm
RA06	24366102	CF, 1k ohm
RA07	24366102	CF, 1k ohm

Location No.	Part No.	Description
RA08	24366102	CF, 1k ohm
RA09	24366102	CF, 1k ohm
RA11	24366102	CF, 1k ohm
RA13	24366102	CF, 1k ohm
RA14	24366102	CF, 1k ohm
RA15	24366102	CF, 1k ohm
RA16	24366102	CF, 1k ohm
RA17	24366431	CF, 430 ohm
RA18	24366431	CF, 430 ohm
RA19	24366431	CF, 430 ohm
RA20	24366431	CF, 430 ohm
RA22	24366222	CF, 2200 ohm
RA23	24366222	CF, 2200 ohm
RA24	24366222	CF, 2200 ohm
RA25	24366222	CF, 2200 ohm
RA26	24366102	CF, 1k ohm
RA27	24366102	CF, 1k ohm
RA31	24366103	CF, 10k ohm
RA32	24366103	CF, 10k ohm
RA33	24366102	CF, 1k ohm
RA34	24366102	CF, 1k ohm
RA35	24366103	CF, 10k ohm
RA36	24366103	CF, 10k ohm
RA37	24366101	CF, 100 ohm
RA38	24366101	CF, 100 ohm
RA40	24366102	CF, 1k ohm
RA41	24366102	CF, 1k ohm
RA43	24366202	CF, 2k ohm
RA44	24366363	CF, 36k ohm
RA45	24366124	CF, 120k ohm
RA46	24366183	CF, 18k ohm
RA47	24366363	CF, 36k ohm
RA48	24366202	CF, 2k ohm
RA54	24366101	CF, 100 ohm
RA55	24366183	CF, 18k ohm
RA56	24366562	CF, 5600 ohm
RA57	24366101	CF, 100 ohm
RA58	24366183	CF, 18k ohm
RA64	24366333	CF, 33k ohm
RA65	24366103	CF, 10k ohm
RA69	24366622	CF, 6200 ohm
RA79	24366101	CF, 100 ohm
RA81	24366101	CF, 100 ohm
RA83	24366103	CF, 10k ohm
RA84	24366363	CF, 36k ohm
RA85	24366473	CF, 47k ohm
RA97	24366103	CF, 10k ohm
RA101	24366102	CF, 1k ohm
RA102	24366102	CF, 1k ohm
RA103	24366102	CF, 1k ohm
RA104	24366331	CF, 330 ohm
RA105	24366102	CF, 1k ohm
RA106	24366473	CF, 47k ohm
RA107	24366102	CF, 1k ohm
RA110	24366103	CF, 10k ohm
RA111	24366563	CF, 56k ohm
RA113	24366109	CF, 1 ohm
RA114	24366153	CF, 15k ohm
RA115	24366272	CF, 2700 ohm
RA116	24366272	CF, 2700 ohm
RA117	24366272	CF, 2700 ohm
RA118	24366272	CF, 2700 ohm
RA119	24366102	CF, 1k ohm
RA120	24366102	CF, 1k ohm

Location No.	Part No.	Description
RA121	24366102	CF, 1k ohm
RA122	24366103	CF, 10k ohm
RA123	24366823	CF, 82k ohm
RA160	24366752	CF, 7500 ohm
RA161	24366752	CF, 7500 ohm
RA162	24366113	CF, 11k ohm
RA163	24366163	CF, 16k ohm
RA164	24366303	CF, 30k ohm
RA165	24366683	CF, 68k ohm
RA208	24366103	CF, 10k ohm
RA213	24366333	CF, 33k ohm
RA214	24366333	CF, 33k ohm
RA215	24366333	CF, 33k ohm
RA216	24366154	CF, 150k ohm
RA315	24366102	CF, 1k ohm
RA317	24366103	CF, 10k ohm
RA854	24366104	CF, 100k ohm
RB25	24366222	CF, 2200 ohm
RB57	24366301	CF, 300 ohm
RB58	24366244	CF, 240k ohm
RB59	24366133	CF, 13k ohm
RB60	24366392	CF, 3900 ohm
RB61	24366103	CF, 10k ohm
RB62	24366103	CF, 10k ohm
RB63	24366103	CF, 10k ohm
RB64	24366103	CF, 10k ohm
RBB25	24366222	CF, 2200 ohm
RBB30	24366331	CF, 330 ohm
RBB31	24366244	CF, 240k ohm
RBB32	24366103	CF, 10k ohm
RBB33	24366103	CF, 10k ohm
RBB44	24366392	CF, 3900 ohm
RBB47	24366133	CF, 13k ohm
△RD01	24000211	FR, 15 ohm, 1/2W
RD02	24322479	OMF, 4.7 ohm, 1W
RD03	24366562	CF, 5600 ohm
RD04	24552102	OMF, 1k ohm, 1/2W
RD05	24552332	OMF, 3300 ohm, 1/2W
RD06	24366912	CF, 9100 ohm
RD07	24366273	CF, 27k ohm
RD08	24366114	CF, 110k ohm
RD09	24366153	CF, 15k ohm
RD10	24366153	CF, 15k ohm
RD11	24003924	MF, 3300 ohm, 1/4W
RD19	24553513	OMF, 51k ohm, 1W
RE83	24366102	CF, 1k ohm
△RF02	24384240	OMF, 24 ohm, 3W
△RF03	24510479	Cement, 4.7 ohm, 5W
△RF29	24383123	OMF, 12k ohm, 2W
RG01	24366101	CF, 100 ohm
RG02	24366101	CF, 100 ohm
RG33	24366102	CF, 1k ohm
RG34	24366102	CF, 1k ohm
RM02	24366102	CF, 1k ohm
RM03	24366102	CF, 1k ohm
RM04	24366153	CF, 15k ohm
RM05	24366153	CF, 15k ohm
RM06	24366202	CF, 2k ohm
RM62	24366512	CF, 5100 ohm
RM63	24366512	CF, 5100 ohm
RM64	24366223	CF, 22k ohm
RM73	24366272	CF, 2700 ohm
RM74	24366361	CF, 360 ohm
RN13	24366103	CF, 10k ohm

Location No.	Part No.	Description
RN14	24366823	CF, 82k ohm
RN15	24366103	CF, 10k ohm
RN16	24366823	CF, 82k ohm
RN18	24366272	CF, 2700 ohm
RN41	24366102	CF, 1k ohm
RN42	24366102	CF, 1k ohm
RN86	24366472	CF, 4700 ohm
RN90	24366222	CF, 2200 ohm
RN91	24366183	CF, 18k ohm
RN92	24366103	CF, 10k ohm
RN93	24366183	CF, 18k ohm
RN94	24366103	CF, 10k ohm
RN95	24366222	CF, 2200 ohm
RS01	24366104	CF, 100k ohm
RS03	24366104	CF, 100k ohm
RS04	24366103	CF, 10k ohm
RS05	24366102	CF, 1k ohm
RS06	24366103	CF, 10k ohm
RS07	24366103	CF, 10k ohm
RS08	24366103	CF, 10k ohm
RS09	24366102	CF, 1k ohm
RS10	24366103	CF, 10k ohm
RS12	24366103	CF, 10k ohm
RS14	24366103	CF, 10k ohm
RS26	24366101	CF, 100 ohm
RS27	24366101	CF, 100 ohm
RS42	24366222	CF, 2200 ohm
RS43	24366222	CF, 2200 ohm
RS44	24366472	CF, 4700 ohm
RS45	24366472	CF, 4700 ohm
RS50	24366103	CF, 10k ohm
RS51	24366103	CF, 10k ohm
RS52	24366821	CF, 820 ohm
△RS53	24545150	FR, 15 ohm, 1/4W
RV01	24366750	CF, 75 ohm
RV02	24366472	CF, 4700 ohm
RV03	24366102	CF, 1k ohm
RV04	24366102	CF, 1k ohm
RV05	24366471	CF, 470 ohm
RV06	24366471	CF, 470 ohm
RV07	24366103	CF, 10k ohm
RV08	24366821	CF, 820 ohm
△RV09	24000665	FR, 15 ohm, 1/4W
RV10	24366272	CF, 2700 ohm
RV11	24366471	CF, 470 ohm
RV12	24366301	CF, 300 ohm
RV13	24366471	CF, 470 ohm
RV14	24366911	CF, 910 ohm
RV15	24366561	CF, 560 ohm
RV16	24366102	CF, 1k ohm
RV17	24366561	CF, 560 ohm
RV18	24366471	CF, 470 ohm
RV19	24366103	CF, 10k ohm
RV20	24366562	CF, 5600 ohm
RV26	24366221	CF, 220 ohm
RV30	24366332	CF, 3300 ohm
RV38	24366104	CF, 100k ohm
RV39	24366104	CF, 100k ohm
RV81	24366750	CF, 75 ohm
RV82	24366750	CF, 75 ohm
RV83	24366302	CF, 3k ohm
RV84	24366750	CF, 75 ohm
RV85	24366750	CF, 75 ohm
RV103	24366101	CF, 100 ohm

Location No.	Part No.	Description
RV110	24366750	CF, 75 ohm
RV117	24366471	CF, 470 ohm
RY11	24366222	CF, 2200 ohm
RY12	24366202	CF, 2k ohm
RY15	24366682	CF, 6800 ohm
RY16	24366102	CF, 1k ohm
RY17	24366822	CF, 8200 ohm
RY53	24066927	VR, 5k ohm, 1/10W
RZ01	24552221	OMF, 220 ohm, 1/2W
RZ02	24366221	CF, 220 ohm
RZ04	24366222	CF, 2200 ohm
RZ06	24366821	CF, 820 ohm
RZ07	24366331	CF, 330 ohm
RZ08	24366101	CF, 100 ohm
RZ09	24366681	CF, 680 ohm
RZ10	24366222	CF, 2200 ohm
RZ11	24366102	CF, 1k ohm
RZ12	24366820	CF, 82 ohm
RZ13	24366102	CF, 1k ohm
RZ14	24366102	CF, 1k ohm
RZ15	24366151	CF, 150 ohm
RZ16	24366911	CF, 910 ohm
RZ17	24366152	CF, 1500 ohm
RZ18	24366331	CF, 330 ohm
RZ19	24366182	CF, 1800 ohm
RZ20	24366102	CF, 1k ohm
RZ23	24366122	CF, 1200 ohm
RZ24	24366102	CF, 1k ohm
RZ25	24366681	CF, 680 ohm
RZ26	24552101	OMF, 100 ohm, 1/2W
RZ28	24366222	CF, 2200 ohm
RZ29	24366470	CF, 47 ohm
RZ30	24552101	OMF, 100 ohm, 1/2W
RZ31	24366680	CF, 68 ohm
RZ50	24066878	VR, 2k ohm, 0.3W
<b>COILS &amp; TRANSFORMERS</b>		
L060	23237975	Coil, Peaking, TRF4101AC
L220	23238718	Coil, Peaking, TRF4479AJ
L221	23238562	Coil, Peaking, TRF4109AJ
L260	23238718	Coil, Peaking, TRF4479AJ
L301	23103940	Coil (Ferrite Bead), TEM2001
L302	23238702	Coil, Peaking, TRF4101AJ
L401	23238714	Coil, Peaking, TRF4100AJ
L402	23238714	Coil, Peaking, TRF4100AJ
L403	23238714	Coil, Peaking, TRF4100AJ
△L441	23233953	Coil, Linearity, TLN2131G
L442	23221894	Coil, Choke, TLN3063
△L462	23231033	Deflection Yoke, YS-59790
L501	23238705	Coil, Peaking, TRF4560AJ
L702	23261974	Coil, Choke, HC5-035
L703	23289390	Coil, Peaking, TRF4390AF
L704	23103859	Coil (Ferrite Bead), TEM2011
L705	23103859	Coil (Ferrite Bead), TEM2011
L860	23103880	Coil (Ferrite Bead), TEM2011Y
L861	23103880	Coil (Ferrite Bead), TEM2011Y
L862	23103880	Coil (Ferrite Bead), TEM2011Y
L881	23103880	Coil (Ferrite Bead), TEM2011Y
L882	23103880	Coil (Ferrite Bead), TEM2011Y
L883	23103880	Coil (Ferrite Bead), TEM2011Y
L884	23103880	Coil (Ferrite Bead), TEM2011Y
L885	23103880	Coil (Ferrite Bead), TEM2011Y
L886	23103880	Coil (Ferrite Bead), TEM2011Y
L887	23103880	Coil (Ferrite Bead), TEM2011Y

Location No.	Part No.	Description
L888	23103880	Coil (Ferrite Bead), TEM2011Y
L889	23221746	Coil, Choke, TLN3155D
L890	23103880	Coil (Ferrite Bead), TEM2011Y
△ L901	23200200	Coil, Degaussing, TSB-2321BT
L901(U901)	23237975	Coil, Peaking, TRF4101AC
L902	23289101	Coil, Peaking, TRF4101AF
L903	23289101	Coil, Peaking, TRF4101AF
L904	23289101	Coil, Peaking, TRF4101AF
L905	23289390	Coil, Peaking, TRF4390AF
L906	23289390	Coil, Peaking, TRF4390AF
L907	23289390	Coil, Peaking, TRF4390AF
L908	23289100	Coil, Peaking, TRF4100AF
LA01	23262274	Coil, IF, TRF1147D
LA02	23262996	Coil, IF, TRF1169D
LA06	23237987	Coil, Peaking, TRF4100AC
LA42	23238562	Coil, Peaking, TRF4109AJ
LD02	23221885	Coil, Choke, TLN3072
LF01	23221746	Coil, Choke, TLN3155D
LF02	23221746	Coil, Choke, TLN3155D
LV01	23238714	Coil, Peaking, TRF4100AJ
LV02	23237975	Coil, Peaking, TRF4101AC
LV05	23237978	Coil, Peaking, TRF4560AC
LV08	23237988	Coil, Peaking, TRF4829AC
LY02	23238727	Coil, Peaking, TRF4332AI
LZ01	23103880	Coil (Ferrite Bead), TEM2011Y
LZ02	23237976	Coil, Peaking, TRF4820AC
LZ03	23238714	Coil, Peaking, TRF4100AJ
LZ04	23238718	Coil, Peaking, TRF4479AJ
LZ05	23103880	Coil (Ferrite Bead), TEM2011Y
LZ06	23238720	Coil, Peaking, TRF4339AJ
LZ07	23103880	Coil (Ferrite Bead), TEM2011Y
LZ08	23103880	Coil (Ferrite Bead), TEM2011Y
LZ09	23103880	Coil (Ferrite Bead), TEM2011Y
LZ10	23103880	Coil (Ferrite Bead), TEM2011Y
T401	23224336	Transformer, Horiz. Drive, TLN1083
△ T461	23236456	Transformer, Flyback, TFB4118ZD
△ T801	23211003	Line Filter, TRF3174
△ T802	23211003	Line Filter, TRF3174
△ T840	23213513	Transformer, Power, TPW1459AZ
△ T862	23217170	Transformer, Converter, TPW3249AD
<b>SEMICONDUCTORS</b>		
IC301	B0378560	IC, TA8427K
IC302	B0384683	IC, TA8859AP
IC501	B0384609	IC, TA8845BN
IC610	B0377305	IC, TA8218AH
△ IC801	23319956	IC, STR-M6515
IC840	23318299	IC, L78MR05
ICA01	23904796	IC, TMP87CM34N-3048
ICA02	23319954	IC, μPD6274CX
ICA03	23904259	IC, μPD6453CY526
ICA05	B0487098	IC, TC74HC4094AP
ICA17	70119743	IC, PST523D
ICF01	23319203	IC, MC7812CT
ICF02	23319203	IC, MC7812CT
ICF03	23319202	IC, MC7809CT
ICF04	23319199	IC, MC7805CT
ICM02	B0384695	IC, TA8862P
ICN05	B0347500	IC, TA75358P
ICV01	B0384763	IC, TA8851BN

Location No.	Part No.	Description
ICZ01	B0589605	IC, TL8721P
Q180	A6012040	Transistor, RN2204
Q200	A6330059	Transistor, 2SC2482(C)
Q206	A6317440	Transistor, 2SC1815-Y
Q220	23314055	Transistor, 2SA564A-Q
Q241	A6002040	Transistor, RN1204
Q242	A6317440	Transistor, 2SC1815-Y
Q243	A6002040	Transistor, RN1204
Q263	A6534053	Transistor, 2SA1015-Y(TE)
Q270	A6534053	Transistor, 2SA1015-Y(TE)
Q303	A6848520	Transistor, 2SD880-Y
Q304	A6317440	Transistor, 2SC1815-Y
Q381	A6534053	Transistor, 2SA1015-Y(TE)
Q401	A6324961	Transistor, 2SC2229-Y
Q402	A678971D	Transistor, 2SC1569 FA-5
Q403	A6317440	Transistor, 2SC1815-Y
△ Q404	A6872801	Transistor, 2SD2253
Q421	A6317440	Transistor, 2SC1815-Y
Q422	A6534053	Transistor, 2SA1015-Y(TE)
Q471	A6534036	Transistor, 2SA1015-O(TE)
Q472	A6317440	Transistor, 2SC1815-Y
Q701	23114528	Transistor, 2SC1740S-Q
Q704	A6734590	Transistor, 2SC752(G)TM-Y
Q705	23114528	Transistor, 2SC1740S-Q
Q706	23114528	Transistor, 2SC1740S-Q
Q707	A6734590	Transistor, 2SC752(G)TM-Y
Q709	23114528	Transistor, 2SC1740S-Q
Q710	23114530	Transistor, 2SA933S-Q
Q711	A6546665	Transistor, 2SA1306-Y
Q712	A6359135	Transistor, 2SC3298A-Y
Q713	A6317440	Transistor, 2SC1815-Y
Q716	23114528	Transistor, 2SC1740S-Q
Q717	23114528	Transistor, 2SC1740S-Q
Q719	23114528	Transistor, 2SC1740S-Q
Q720	23114528	Transistor, 2SC1740S-Q
△ Q841	A8643135	Photo Coupler, TLP621(GRL)
△ Q845	A6907751	IC, S1854
Q862	23114528	Transistor, 2SC1740S-Q
Q863	23114528	Transistor, 2SC1740S-Q
Q870	A6532853	Transistor, 2SA949-Y(C)
Q901	A6368700	Transistor, 2SC4544
Q902	23114528	Transistor, 2SC1740S-Q
Q903	A6368700	Transistor, 2SC4544
Q904	23114528	Transistor, 2SC1740S-Q
Q905	A6368700	Transistor, 2SC4544
Q906	23114528	Transistor, 2SC1740S-Q
Q907	A6509154	Transistor, 2SA562TM-Y(T)
Q908	A6321265	Transistor, 2SC2120-Y(TE)
QA11	A6534053	Transistor, 2SA1015-Y(TE)
QA15	A6342206	Transistor, 2SC2878-A(TE)
QA16	A6342206	Transistor, 2SC2878-A(TE)
QA19	23114457	Transistor, DTC143E S
QA20	A6002020	Transistor, RN1202
QA61	23114528	Transistor, 2SC1740S-Q
QB24	A6534053	Transistor, 2SA1015-Y(TE)
QB59	A6534053	Transistor, 2SA1015-Y(TE)
QB60	A6317440	Transistor, 2SC1815-Y
QB61	A6002040	Transistor, RN1204
QBB24	23314055	Transistor, 2SA564A-Q
QBB44	23114552	Transistor, 2SC1685-Q
QBB46	23314055	Transistor, 2SA564A-Q
QD01	A6625365	Transistor, 2SB688-O(BS)
QD02	A6317440	Transistor, 2SC1815-Y
QD03	A6317440	Transistor, 2SC1815-Y

Location No.	Part No.	Description
QE06	23114528	Transistor, 2SC1740S-Q
QE07	A6010060	Transistor, RN2006
QM03	23114528	Transistor, 2SC1740S-Q
QM04	23314055	Transistor, 2SA564A-Q
QN13	A6342206	Transistor, 2SC2878-A(TE)
QN14	A6342206	Transistor, 2SC2878-A(TE)
QS38	23114528	Transistor, 2SC1740S-Q
QS49	23114528	Transistor, 2SC1740S-Q
QV07	23114530	Transistor, 2SA933S-Q
QV10	23114530	Transistor, 2SA933S-Q
QV31	23114528	Transistor, 2SC1740S-Q
QV40	23114530	Transistor, 2SA933S-Q
QV41	23114528	Transistor, 2SC1740S-Q
QV42	23114530	Transistor, 2SA933S-Q
QY13	A6317499	Transistor, 2SC1815-BL(T)
QZ02	23114530	Transistor, 2SA933S-Q
QZ03	23114528	Transistor, 2SC1740S-Q
QZ05	23114530	Transistor, 2SA933S-Q
QZ06	23114528	Transistor, 2SC1740S-Q
QZ07	23114528	Transistor, 2SC1740S-Q
QZ08	23114528	Transistor, 2SC1740S-Q
QZ09	23114528	Transistor, 2SC1740S-Q
QZ10	23114528	Transistor, 2SC1740S-Q
D060	23316411	Diode, Zener, HZT33-12
D182	23118859	Diode, 1SS133
D200	23316339	Diode, Zener, UZ15BSB
D204	23118859	Diode, 1SS133
D210	23118859	Diode, 1SS133
D215	23118859	Diode, 1SS133
D216	23118859	Diode, 1SS133
D217	23118859	Diode, 1SS133
D218	23118859	Diode, 1SS133
D219	23118859	Diode, 1SS133
D220	23118859	Diode, 1SS133
D221	23316339	Diode, Zener, UZ15BSB
D222	23316339	Diode, Zener, UZ15BSB
D223	23316339	Diode, Zener, UZ15BSB
D224	23316339	Diode, Zener, UZ15BSB
D225	23118859	Diode, 1SS133
D226	23316339	Diode, Zener, UZ15BSB
D228	23118859	Diode, 1SS133
D229	23118859	Diode, 1SS133
D260	23316311	Diode, Zener, UZ6.2BSA
D261	23118859	Diode, 1SS133
D265	23316339	Diode, Zener, UZ15BSB
D271	23118859	Diode, 1SS133
D287	23118859	Diode, 1SS133
D288	23118859	Diode, 1SS133
D290	23118859	Diode, 1SS133
D291	23316301	Diode, Zener, UZ4.7BSA
D301	23118094	Diode, EU2A
D302	23118094	Diode, EU2A
D303	A7150258	Diode, 1SS176
D306	23316321	Diode, Zener, UZ8.2BSB
D307	23316291	Diode, Zener, UZ3.0BSB
D308	23118822	Diode, ERB12-02
D309	23118822	Diode, ERB12-02
D310	23316351	Diode, Zener, UZ22BSB
D332	23316794	Diode, SC570A
D340	23118859	Diode, 1SS133
D381	23316309	Diode, Zener, UZ5.6BSB
D401	23316333	Diode, Zener, UZ12BSB
D402	23118516	Diode, Zener, RD9.1ESA B3
D403	23316284	Diode, Zener, UZ2.2BSA

Location No.	Part No.	Description
D404	23316306	Diode, Zener, UZ5.1BSB
D405	23316792	Diode, SC215
D406	23118094	Diode, EU2A
D440	23118094	Diode, EU2A
D441	23316355	Diode, Zener, UZ24BSB
D471	A7568460	Diode, TVR-1B
△D472	23115774	Diode, Zener, RD6.2E(4)
D473	23118859	Diode, 1SS133
D474	23316333	Diode, Zener, UZ12BSB
D492	23118859	Diode, 1SS133
D601	23118859	Diode, 1SS133
D602	23118859	Diode, 1SS133
D605	23118859	Diode, 1SS133
D606	23118859	Diode, 1SS133
D607	23118859	Diode, 1SS133
D608	23118859	Diode, 1SS133
D704	23118859	Diode, 1SS133
D705	23118859	Diode, 1SS133
D706	A7568475	Diode, TVR-2D
D707	A7568475	Diode, TVR-2D
D711	23118859	Diode, 1SS133
D712	23118859	Diode, 1SS133
D720	23118859	Diode, 1SS133
D721	23118859	Diode, 1SS133
D801	23316795	Diode, D6SB60L, F05
D840	23115532	Diode, ERB12-01
D841	23115532	Diode, ERB12-01
D842	23115532	Diode, ERB12-01
D843	23115532	Diode, ERB12-01
D844	A7150258	Diode, 1SS176
D845	A7150351	Diode, 1SS178
D846	23316332	Diode, Zener, UZ12BSA
D860	A7116905	Diode, Zener, 04AZ9.1X
D861	A7118115	Diode, Zener, 04AZ30Y
D862	A7801166	SCR, SF0R3G42-IG5
D863	A7568719	Diode, 1S1887
D864	23118094	Diode, EU2A
D865	23118094	Diode, EU2A
D866	23118094	Diode, EU2A
D867	23316327	Diode, Zener, UZ10BSB
D870	23316370	Diode, Zener, UZ36BSA
D878	23316370	Diode, Zener, UZ36BSA
D879	A7150351	Diode, 1SS178
D883	23316406	Diode, FML-G16S
D884	23316475	Diode, FMP-G12S
D885	23316475	Diode, FMP-G12S
D888	23118339	Diode, Zener, R2M
D895	23118859	Diode, 1SS133
D901	23118859	Diode, 1SS133
D902	23118859	Diode, 1SS133
D903	23118859	Diode, 1SS133
D904	23118859	Diode, 1SS133
D905	23118859	Diode, 1SS133
D906	23118859	Diode, 1SS133
D907	23118859	Diode, 1SS133
D908	23118859	Diode, 1SS133
D909	23118859	Diode, 1SS133
D910	23118859	Diode, 1SS133
D911	A7568250	Diode, 1S1834
D912	23118859	Diode, 1SS133
D913	23118859	Diode, 1SS133
D914	23118859	Diode, 1SS133
DA04	23316312	Diode, Zener, UZ6.2BSB
DA07	23316326	Diode, Zener, UZ10BSA

Location No.	Part No.	Description
DA10	23316308	Diode, Zener, UZ5.6BSA
DA11	23118859	Diode, 1SS133
DA12	23118859	Diode, 1SS133
DA25	23118859	Diode, 1SS133
DA31	23316311	Diode, Zener, UZ6.2BSA
DA32	23316311	Diode, Zener, UZ6.2BSA
DA33	23316311	Diode, Zener, UZ6.2BSA
DA34	23118859	Diode, 1SS133
DA42	23316312	Diode, Zener, UZ6.2BSB
DA71	23316312	Diode, Zener, UZ6.2BSB
DB60	23118859	Diode, 1SS133
DD01	A7568460	Diode, TVR-1B
DD02	23316582	Diode, ERC20-06
DD03	A7568752	Diode, 1S1887A
DD04	23118859	Diode, 1SS133
DD05	23316332	Diode, Zener, UZ12BSA
DD07	A7568200	Diode, 1S1832
DD08	23316309	Diode, Zener, UZ5.6BSB
DD09	23316309	Diode, Zener, UZ5.6BSB
DE50	23358504	Diode (LED), SCL003URC3FX, Red
DM01	23118859	Diode, 1SS133
DN15	23316285	Diode, Zener, UZ2.2BSB
DV01	23316327	Diode, Zener, UZ10BSB
DV02	23316327	Diode, Zener, UZ10BSB
DV03	23316327	Diode, Zener, UZ10BSB
DV04	23316327	Diode, Zener, UZ10BSB
DV07	23316327	Diode, Zener, UZ10BSB
DV10	23118859	Diode, 1SS133
DV11	23118859	Diode, 1SS133
DV12	23118859	Diode, 1SS133
DV13	23118859	Diode, 1SS133
DV19	23316312	Diode, Zener, UZ6.2BSB
DV20	23316312	Diode, Zener, UZ6.2BSB
DY01	23118859	Diode, 1SS133
DZ01	A7116305	Diode, Zener, 04AZ5.1X
DZ02	A7116915	Diode, Zener, 04AZ9.1Y
<b>MISCELLANEOUS</b>		
BB01	23902749	Connector, 6P
BB03	23902749	Connector, 6P
BB04	23902750	Connector, 7P
BB05	23902750	Connector, 7P
BB06	23902749	Connector, 6P
BB07	23902750	Connector, 7P
BB14	23368517	Connector, 6P
BB15	23368518	Connector, 7P
BB16	23368518	Connector, 7P
BB17	23368517	Connector, 6P
BB18	23368517	Connector, 6P
BB20	23368518	Connector, 7P
△F801	23144888	Fuse, 5.0A
F801A	23165433	Holder, Fuse
△F803	23144735	Fuse, 5.0A
F803A	23165433	Holder, Fuse
△F804	23144804	Fuse, 1.25A
F804A	23165433	Holder, Fuse
△F883	23144735	Fuse, 5.0A
F883A	23165433	Holder, Fuse
△F884	23144849	Fuse, 2.0A
F884A	23165433	Holder, Fuse
H002	23148176	Module, PIF/MPX/S.PRO, US, MVUS32S
K910	23120219	Remote Sensor, IR-9106A-K

Location No.	Part No.	Description
P001	23365089	F Connector, Antenna Terminal
P003	23161675	Terminal, 4P
△P801	23176870	Power Cord
P900	23368234	Plug, 3P
P901	23164725	Plug, 2P
PS10	23365711	Jack, 1S6P
PS11	23365711	Jack, 1S6P
PS20	23365711	Jack, 1S6P
PS21	23365711	Jack, 1S6P
PS40	23365746	Jack, 8P
PS41	23365746	Jack, 8P
PS50	23365746	Jack, 8P
PS51	23365746	Jack, 8P
PS62	23365746	Jack, 8P
PS63	23365746	Jack, 8P
PV01B	23368520	Connector, 20P
PV02B	23368531	Connector, 12P
PV10	23365711	Jack, 1S6P
PV11	23365711	Jack, 1S6P
PV21	23365711	Jack, 1S6P
PV30	23902863	Connector, 20P
PV31	23902781	Connector, 12P
PV40	23365746	Jack, 8P
PV51	23365746	Jack, 8P
PV63	23164560	Plug, 6P
PZ01	23368006	Connector, 8P
PZ01A	23902743	Connector, 8P
S301	23344130	Switch, Lever, 1C3P
S601	23145356	Switch, Slide, 4C2P
SA01	23145226	Switch, Push, 1C1P
SA02	23145226	Switch, Push, 1C1P
SA05	23145226	Switch, Push, 1C1P
SA06	23145226	Switch, Push, 1C1P
SA07	23145226	Switch, Push, 1C1P
SA08	23145226	Switch, Push, 1C1P
SA09	23145226	Switch, Push, 1C1P
SA10	23145226	Switch, Push, 1C1P
△SR81	23146547	Relay, DC12V, AC120V5A
△V901A	23902068	Socket, CRT, 10P
W661	23151258	Speaker, SPK-1258, 70x130mm, 8 ohm
W662	23151258	Speaker, SPK-1258, 70x130mm, 8 ohm
X201	23250120	Coil, Delay-Line, TRF2133T
X401	23153721	Ceramic Resonator, 503kHz, TCR1023
X501	23153961	Crystal, 3.58MHz
XA01	23153395	Ceramic Resonator, 7.76MHz, TCR1063
ZM03	23153721	Ceramic Resonator, 503kHz, TCR1023
ZY01	23148210	Module, PIP, PMUS01H
<b>PC BOARD ASSEMBLIES</b>		
U601	23703193	Speaker Terminal Board, PB4768-3
U801	23703186	Power/Def Board, PB4766
U901	23703188	CRT Drive/SM Board, PB4768-2
U902	23700504	Signal & Control Board, PB4767
UV01	23703189	A/V Board, PB4768-1

Location No.	Part No.	Description
UZ01	23702968	S-CCD Board, PB4648
<b>PICTURE TUBE</b>		
△ V901	23312595	Picture Tube, A89LFL50X02(V)
	23102395	P/C Magnet, TP-11900B2X
<b>TUNER</b>		
△ H001	23321140	Tuner, UHF/VHF, EL859L2
<b>ACCESSORIES</b>		
K912	23120529	Remote Hand Unit, CT-9727
Y101	23562118	Owner's Manual, English, CF35D50
Y101	23562161	Owner's Manual, English/French, TV35D50
Y106	23994678	TESC Sheet
Y107	23142003	Adapter, Antenna Matching, AD503J

Location No.	Part No.	Description
--------------	----------	-------------

SIGNAL BOARD PB4767-1  
BOTTOM (FOIL) SIDE

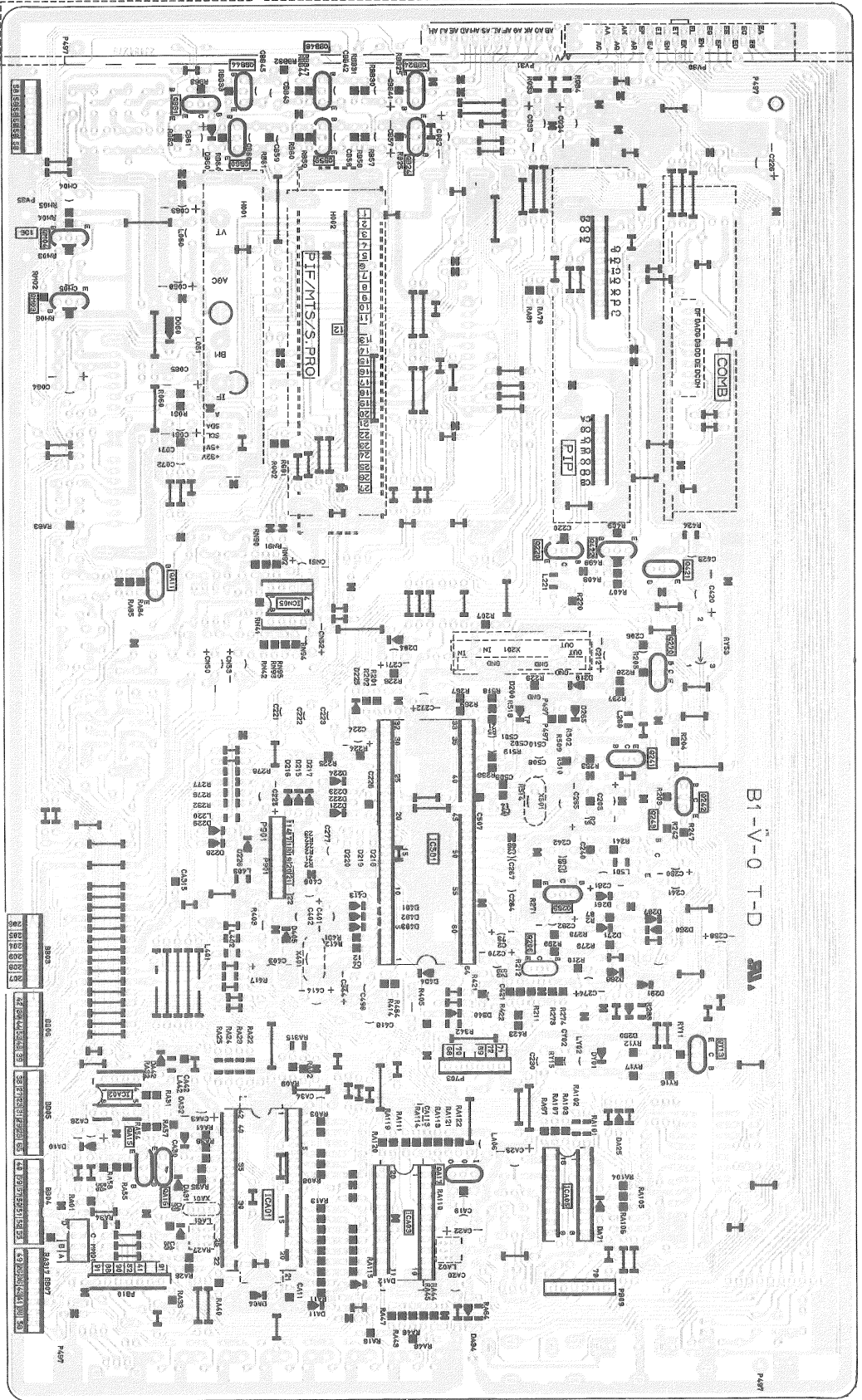

POWER/DEF BOARD PB4766  
BOTTOM (FOIL) SIDE

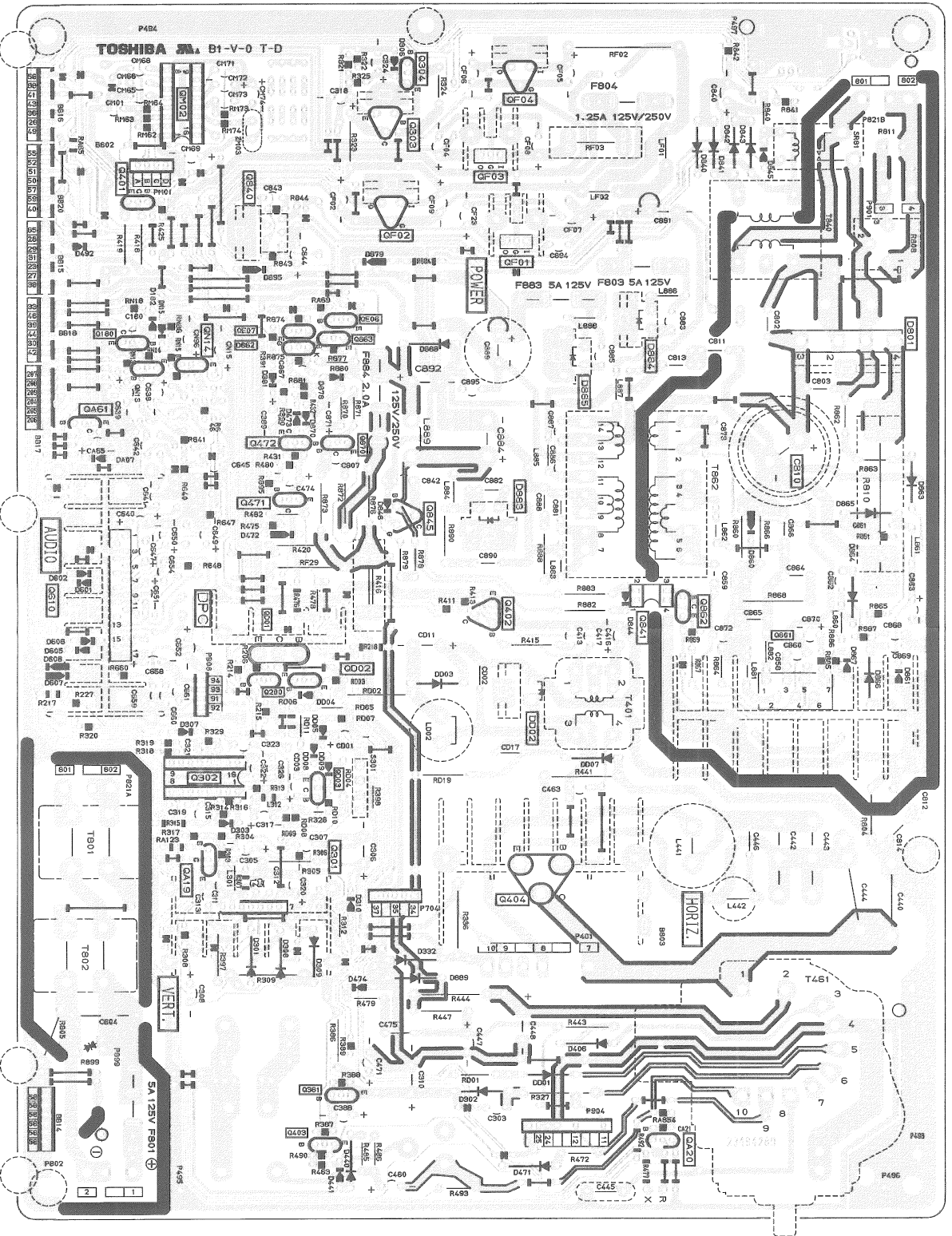

# A/V BOARD PB4768-1

BOTTOM (FOIL) SIDE

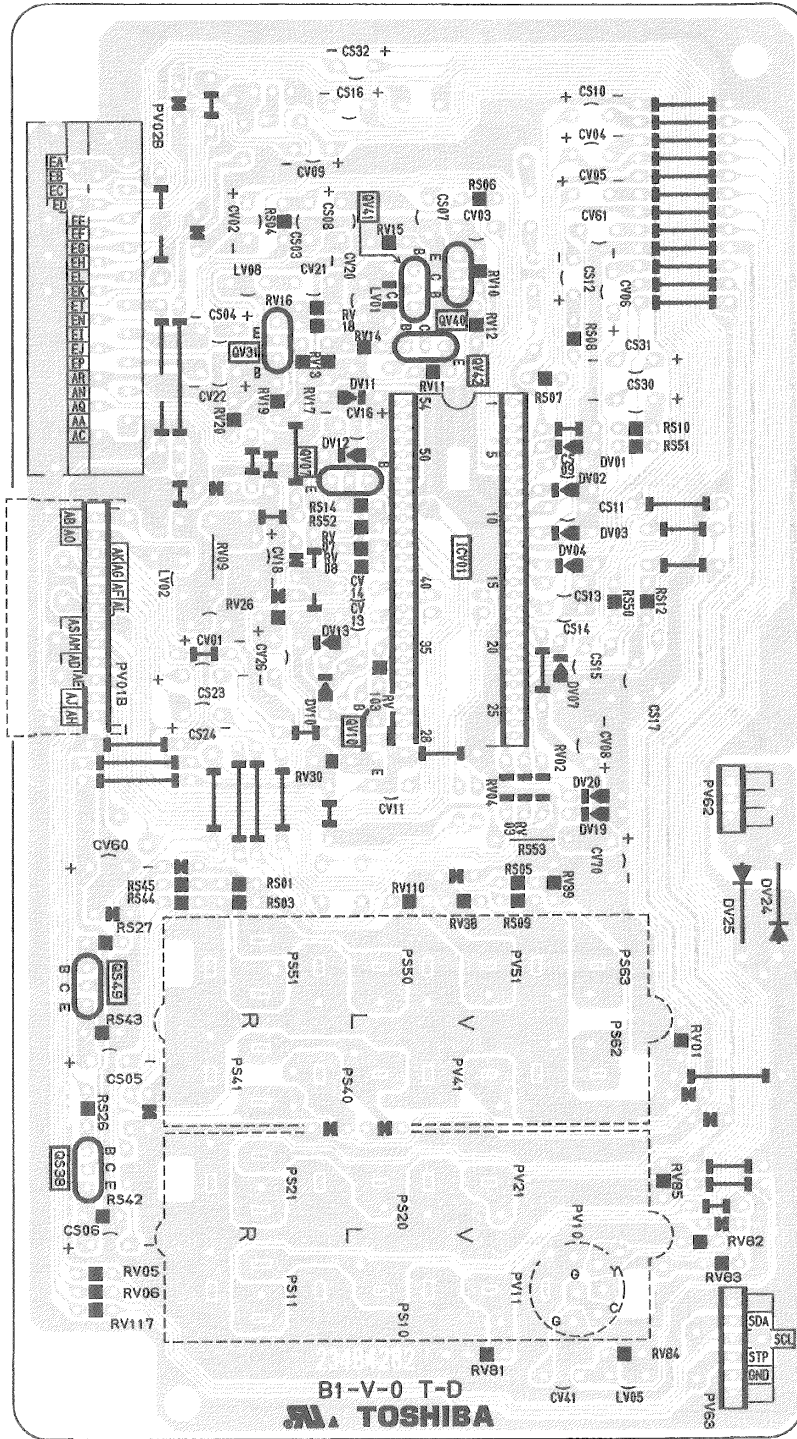

CRT. D/SM BOARD PB4768-2  
BOTTOM (FOIL) SIDE

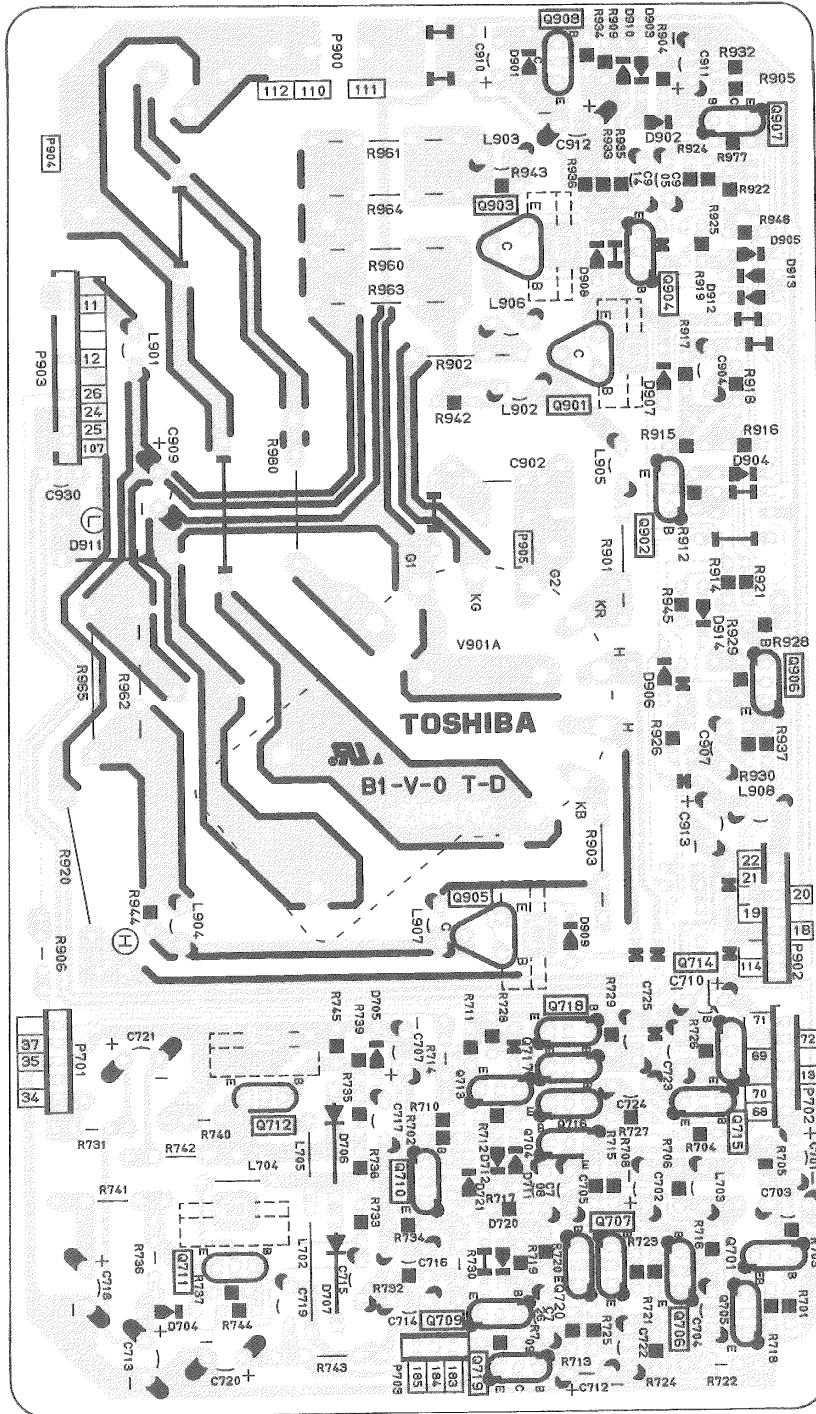

**SP TERMINAL BOARD PB4768-3**  
**BOTTOM (FOIL) SIDE**

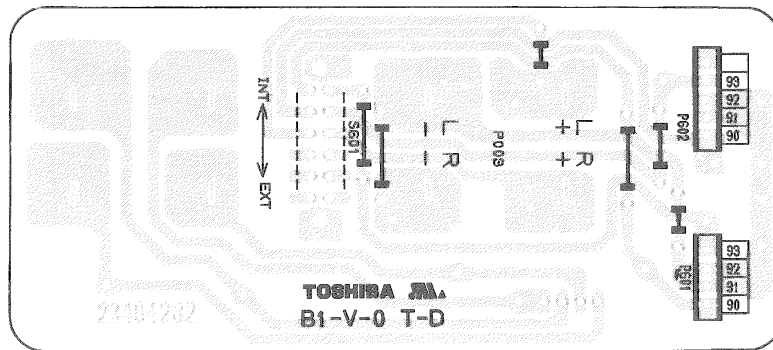

**S-CCD BOARD PB4648**  
**BOTTOM (FOIL) SIDE**

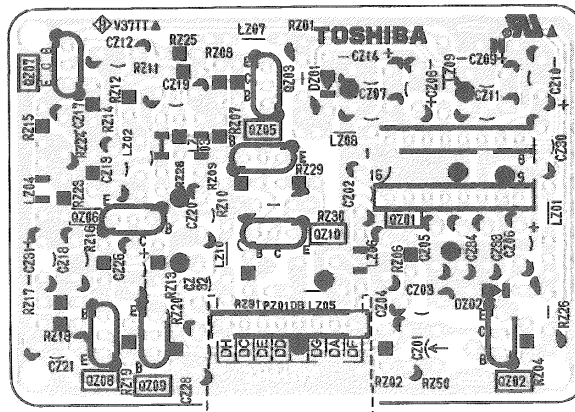



# TERMINAL VIEW OF TRANSISTORS

① 2SC1569  
2SD2023  
2SD880



② 2SC2229  
2SC2655



③ 2SA562TM  
2SA949  
2SA1015  
2SC933S  
2SC1815N  
2SC2878  
2SC752GTM



④ RN1003  
RN1201  
RN1204  
RN1206  
RN2204  
RN2206



⑤ 2SB688



⑥ 2SD1428

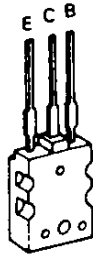

⑦ 2SC2068



⑧ 2SC2712  
2SA1162  
RN1402  
RN1403  
RN1404

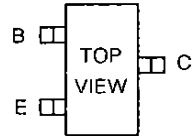

⑨ 2SA1306

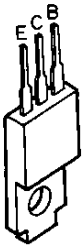

## SPECIFICATIONS

<b>Input Power Rating:</b>	125 W (average), 120 V AC, 60 Hz
<b>Antenna Input Impedance:</b>	75 ohm unbalanced type for VHF, UHF and CATV
<b>Receiving Channels:</b>	VHF channels ..... channels 2 to 13 UHF channels ..... channels 14 to 69 CATV channels ..... Mid-band A8 to A1, A to I Super-band J to W Hyper-band AA to ZZ, AAA, BBB Ultra-band 65 to 94, 100 to 125
<b>Intermediate Frequencies:</b>	Picture I-F carrier frequency ..... 45.75 MHz Sound I-F carrier frequency ..... 41.25 MHz Color sub-carrier frequency ..... 42.17 MHz
<b>Picture Tube:</b>	35 inches, A89LFL50X02(V), 588 sq. inches of viewable area, 110° deflection
<b>Audio Power:</b>	10 W x 2
<b>Speakers:</b>	2-3/4" x 5" square 2 pcs
<b>Cabinet:</b>	Plastic, Table
<b>Dimensions:</b>	Width ..... 34-3/64 inches (876 mm) Height ..... 31-19/64 inches (795 mm) Depth ..... 25-35/64 inches (649 mm)
<b>Mass:</b>	170.5 lbs. (77.3 kg)
<b>Aux. Terminals:</b>	AUDIO/VIDEO INPUT jacks, S-VIDEO INPUT jack, AUDIO OUTPUT (VARIABLE) jacks EXTERNAL SPEAKER terminals
<b>Features:</b>	Frequency synthesized tuning system, 181-channel VHF/UHF/CABLE multi-tuner, 40-key advanced universal remote control, Multichannel TV Sound reception, Front surround sound, Sub-Bass System, Picture-in-Picture, CCD comb filter, Digital control, Closed Captioning

Specifications are subject to change without notice.

