

# TOSHIBA

FILE NO. 050-200106

## SERVICE MANUAL

## COLOR TELEVISION

# 14AF41

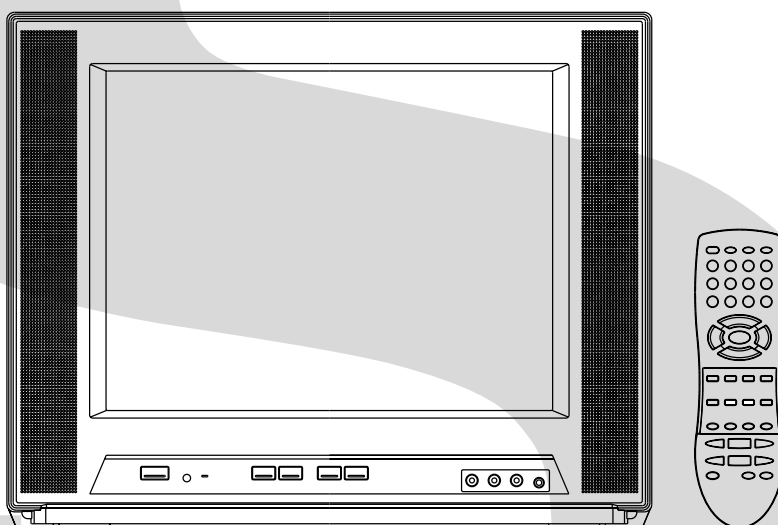

## SERVICING NOTICES ON CHECKING

### 1. KEEP THE NOTICES

As for the places which need special attentions, they are indicated with the labels or seals on the cabinet, chassis and parts. Make sure to keep the indications and notices in the operation manual.

### 2. AVOID AN ELECTRIC SHOCK

There is a high voltage part inside. Avoid an electric shock while the electric current is flowing.

### 3. USE THE DESIGNATED PARTS

The parts in this equipment have the specific characters of incombustibility and withstand voltage for safety. Therefore, the part which is replaced should be used the part which has the same character.

Especially as to the important parts for safety which is indicated in the circuit diagram or the table of parts as a  mark, the designated parts must be used.

### 4. PUT PARTS AND WIRES IN THE ORIGINAL POSITION AFTER ASSEMBLING OR WIRING

There are parts which use the insulation material such as a tube or tape for safety, or which are assembled in the condition that these do not contact with the printed board. The inside wiring is designed not to get closer to the pyrogenic parts and high voltage parts. Therefore, put these parts in the original positions.

### 5. TAKE CARE TO DEAL WITH THE CATHODE-RAY TUBE

In the condition that an explosion-proof cathode-ray tube is set in this equipment, safety is secured against implosion. However, when removing it or serving from backward, it is dangerous to give a shock. Take enough care to deal with it.

### 6. AVOID AN X-RAY

Safety is secured against an X-ray by considering about the cathode-ray tube and the high voltage peripheral circuit, etc.

Therefore, when repairing the high voltage peripheral circuit, use the designated parts and make sure not modify the circuit.

Repairing except indicates causes rising of high voltage, and it emits an X-ray from the cathode-ray tube.

### 7. PERFORM A SAFETY CHECK AFTER SERVICING

Confirm that the screws, parts and wiring which were removed in order to service are put in the original positions, or whether there are the portions which are deteriorated around the serviced places serviced or not. Check the insulation between the antenna terminal or external metal and the AC cord plug blades. And be sure the safety of that.

#### (INSULATION CHECK PROCEDURE)

1. Unplug the plug from the AC outlet.
2. Remove the antenna terminal on TV and turn on the TV.
3. Insulation resistance between the cord plug terminals and the external exposure metal **[Note 2]** should be more than 1M ohm by using the 500V insulation resistance meter **[Note 1]**.
4. If the insulation resistance is less than 1M ohm, the inspection repair should be required.

#### **[Note 1]**

If you have not the 500V insulation resistance meter, use a Tester.

#### **[Note 2]**

External exposure metal: Antenna terminal  
Earphone jack

## HOW TO ORDER PARTS

Please include the following informations when you order parts. (Particularly the VERSION LETTER.)

#### 1. MODEL NUMBER and VERSION LETTER

The MODEL NUMBER can be found on the back of each product and the VERSION LETTER can be found at the end of the SERIAL NUMBER.

#### 2. PART NO. and DESCRIPTION

You can find it in your SERVICE MANUAL.

## IMPORTANT

Inferior silicon grease can damage IC's and transistors.

When replacing an IC's or transistors, use only specified silicon grease (YG6260M).

Remove all old silicon before applying new silicon.

## GENERAL SPECIFICATIONS

G-1	TV System	CRT	CRT Size / Visual Size	14 inch / 357mmV
			CRT Type	Flat
			Deflection	90 degree
			Magnetic Field BV/BH	+0.45G/0.18G
			Color System	NTSC
			Speaker	2 Speaker
			Position	Front Side
			Size	1.6 x 2.8 Inch
			Impedance	8 ohm
			Sound Output	MAX 2.5+2.5 W
			10%(Typical)	2.0+2.0 W
			NTSC3.58+4.43 /PAL60Hz	No
		G-2	Tuning System	Broadcasting System
Tuner and Receive CH	System			1Tuner
	Destination			Others
	Tuning System			F-Synth
	Input Impedance			VHF/UHF 75 ohm
	CH Coverage			2 - 69, 4A, A-5 - A-1, A - I, J - W, W+1 - W+84
Intermediate Frequency	Picture(FP)			45.75MHz
	Sound(FS)			41.25MHz
	FP-FS			4.50MHz
	Preset CH			No
	Stereo/Dual TV Sound			Yes
	Tuner Sound Muting			Yes
G-3	Power	Power Source	AC	120V AC 60Hz
			DC	
		Power Consumption		at AC
			Stand by (at AC)	80 W at AC 120 V 60 Hz
			Per Year	4 W at AC 120 V 60 Hz
			-- kWh/Year	
	Protector	Power Fuse	Yes	
G-4	Regulation	Safety		UL
		Radiation		FCC
		X-Radiation		DHHS
G-5	Temperature	Operation		+5oC ~ +40oC
		Storage		-20oC ~ +60oC
G-6	Operating Humidity			Less then 80% RH

## GENERAL SPECIFICATIONS

<b>G-7</b>	<b>On Screen Display</b>	Menu	Menu Type	Yes		
			Icon	Yes		
			Picture	Yes		
			Contrast	Yes		
			Brightness	Yes		
			Color	Yes		
			Tint	Yes		
			Sharpness	Yes		
			Sound	Yes		
			Bass	Yes		
			Treble	Yes		
			Balance	Yes		
			Stable Sound On/Off	Yes		
			Set Up	Yes		
			TV/CATV	Yes		
			Auto CH Memory	Yes		
			Add/ Delete	Yes		
			Option	Yes		
			Language	Yes		
			CH Label	Yes		
			Favorite CH	Yes		
			V-Chip	Yes		
			Color Stream DVD/DTV	Yes		
			Control Level	Yes		
			Volume	Yes		
			Brightness	Yes		
			Contrast	Yes		
			Color	Yes		
			Tint (NTSC Only)	Yes		
			Sharpness	Yes		
			Tuning		No	
Bass	Yes					
Treble	Yes					
Balance	Yes					
Back Light		No				
Stereo,Audio Output,SAP	Yes					
Video	Yes					
Color Stream	Yes					
Channel(TV/Cable)	Yes					
CH Label	Yes					
Sleep Timer	Yes					
Sound Mute	Yes					
V-chip Rating	Yes					
<b>G-8</b>	<b>OSD Language</b>		OSD Language Setting	English	French	Spanish
<b>G-9</b>	<b>Clock and Timer</b>	Sleep Timer	Max Time	120 Min		
			Step	10 Min		
		On/Off Timer	Program(On Tim / Off Tim)	No		
		Wake Up Timer		No		
		Timer Back-up (at Power Off Mode)	more than	--	Min	Sec

## GENERAL SPECIFICATIONS

<b>G-10</b>	<b>Remote Control</b>	Unit	RC-DU		
		Glow in Dark Remocon	Yes		
		Format	Toshiba		
		Custom Code	TV:40-BFh		
		Power Source	Voltage(D.C)	3V	
			UM size x pcs	UM-4 x 2 pcs	
		Total Keys		42 Keys	
		Keys	Power	Yes	
			1	Yes	
			2	Yes	
			3	Yes	
			4	Yes	
			5	Yes	
			6	Yes	
			7	Yes	
			8	Yes	
			9	Yes	
			0	Yes	
			100	Yes	
			CH Up/+	Yes	
			CH Down/-	Yes	
			Volume Up/+	Yes	
			Volume Down/-	Yes	
			C.C.(TV/Caption/Text)	Yes	
			CH1/CH2	Yes	
			TV/Video(Input Select)	Yes	
			CH RTN(Quick View)	Yes	
			SLEEP	Yes	
			RECALL(Call)	Yes	
			Reset	Yes	
			Menu/Enter	Yes	
			Mute	Yes	
			Exit	Yes	
			MTS(Audio Select)	Yes	
			Fav. Up	Yes	
			Fav. Down	Yes	
			Multi Brand Keys	CH Up(VCR)	Yes
				CH Down(VCR)	Yes
				Pause/Still	Yes
				TV/VCR(VCR)	Yes
				FF	Yes
				Rew	Yes
Rec	Yes				
Play	Yes				
Stop	Yes				
TV	Yes				
VCR	Yes				
Cable	Yes				
CODE	Yes				

## GENERAL SPECIFICATIONS

<b>G-11</b>	<b>Features</b>	Auto Degauss	Yes	
		Auto Shut Off	Yes	
		Canal+	No	
		CATV	Yes	
		Anti-theft	No	
		Rental	No	
		Memory(Last CH)	Yes	
		Memory(Last Volume)	Yes	
		V-Chip	Yes	
		Type	USA, Toshiba Type	
		BBE	No	
		Auto Search	No	
		CH Allocation	No	
		SAP	Yes	
		Channel Lock	No	
		Just Clock Function	No	
		Game Position	No	
		CH Label	Yes	
		VM Circuit	No	
		Full OSD	No	
		Premiere	No	
		Comb Filter	Yes	
			2 Lines	
		Auto CH Memory	Yes	
		Hotel Lock	No	
		Closed Caption	Yes	
		Stable Sound	Yes	
FBT Leak Test Protect	Yes			
Favorite CH	Yes			
<b>G-12</b>	<b>Accessories</b>	Owner's Manual	Language	English
			W/ Warranty	Yes
		Remote Control Unit		Yes
		Rod Antenna		No
			Poles	
			Terminal	
		Loop Antenna		No
			Terminal	-
		U/V Mixer		No
		DC Car Cord (Center+)		No
		Guarantee Card		No
		Warning Sheet		No
		Circuit Diagram		No
		Antenna Change Plug		No
		Service Station List		No
		Important Safety Instructions		Yes
		Dew/AHC Caution Sheet		No
		AC Plug Adapter		No
		Quick Set-up Sheet		No
		Battery		Yes
			UM size x pcs	UM-4 x 2
			OEM Brand	No
		AC Cord		No
AV Cord (2Pin-1Pin)		No		
Registration Card (NDL Card)		Yes		
PTB Sheet		No		
ESP Card		Yes		
300 ohm to 75 ohm Antenna Adapter		No		

## GENERAL SPECIFICATIONS

<b>G-13</b>	<b>Interface</b>	Switch	Front	Power	Yes	
				System Select	No	
				Main Power SW	No	
				Sub Power	No	
				Channel Up	Yes	
				Channel Down	Yes	
				Volume Up	Yes	
			Volume Down	Yes		
			Rear	AC/DC	No	
				TV/CATV Selector	No	
				Degauss	No	
			Indicator	Main Power SW	No	
				Power	Yes(RED)	
				Stand-by	No	
			Terminals	Front	On Timer	No
		Video Input = VIDEO3			RCA	
		Audio Input = VIDEO3			RCA x 2	
		Rear		Other Terminal	Head Phone	
				Video Input(Rear1) = VIDEO1	RCA	
				Video Input(Rear2) = VIDEO2	RCA	
				Audio Input(Rear1) = VIDEO1	RCA x 2	
				Audio Input(Rear2) = VIDEO2	RCA x 2	
				Video Output	RCA	
				Audio Output	RCA x 2	
				Euro Scart	No	
				Color Stream	RCA x 3	
				S Input	Yes	
				Diversity	No	
				Ext Speaker	No	
		DC Jack 12V(Center +)	No			
VHF/UHF Antenna Input	F Type					
AC Outlet	No					
<b>G-14</b>	<b>Set Size</b>	Approx. W x D x H (mm)		432 x 386 x 344.5		
<b>G-15</b>	<b>Weight</b>	Net (Approx.)		11.0kg (24.3 lbs)		
		Gross (Approx.)		13.0 kg (28.7 lbs)		
<b>G-16</b>	<b>Carton</b>	Master Carton		No		
		Content		---- Sets		
		Material		-- /--		
		Dimensions W x D x H(mm)		-- x -- x --		
		Description of Origin		--		
		Gift Box		Yes		
		Material		Double/Brown		
		Dimensions W x D x H(mm)		515 x 460 x 423		
		Design		As per Buyer's		
		Description of Origin		Yes		
		Drop Test		Natural Dropping At 1 Corner / 3 Edges / 6 Surfaces		
		Height (cm)		62		
		Container Stuffing		575 Sets/40' container		
		<b>G-17</b>	<b>Cabinet Material</b>	Cabinet Front		PS 94V0 DECABROM
				Cabinet Rear		PS 94V0 DECABROM

# DISASSEMBLY INSTRUCTIONS

## 1. REMOVAL OF ANODE CAP

Read the following **NOTED** items before starting work.

- \* After turning the power off there might still be a potential voltage that is very dangerous. When removing the Anode Cap, make sure to discharge the Anode Cap's potential voltage.
- \* Do not use pliers to loosen or tighten the Anode Cap terminal, this may cause the spring to be damaged.

### REMOVAL

1. Follow the steps as follows to discharge the Anode Cap.  
**(Refer to Fig. 1-1.)**  
Connect one end of an Alligator Clip to the metal part of a flat-blade screwdriver and the other end to ground. While holding the plastic part of the insulated Screwdriver, touch the support of the Anode with the tip of the Screwdriver. A cracking noise will be heard as the voltage is discharged.

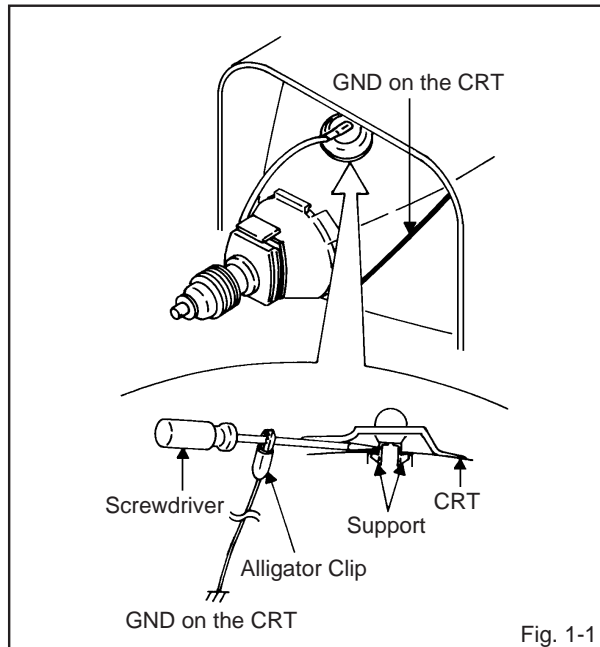

2. Flip up the sides of the Rubber Cap in the direction of the arrow and remove one side of the support.  
**(Refer to Fig. 1-2.)**

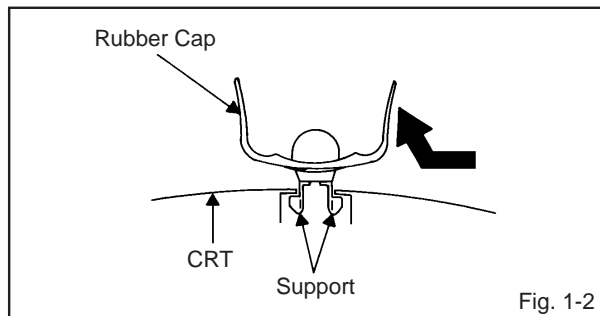

3. After one side is removed, pull in the opposite direction to remove the other.

### NOTE

Take care not to damage the Rubber Cap.

### INSTALLATION

1. Clean the spot where the cap was located with a small amount of alcohol. **(Refer to Fig. 1-3.)**

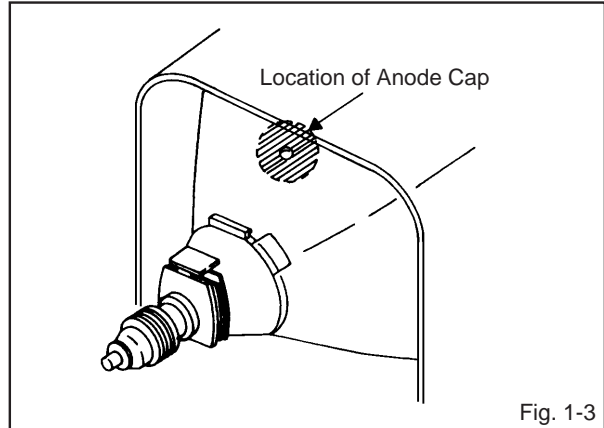

### NOTE

Confirm that there is no dirt, dust, etc. at the spot where the cap was located.

2. Arrange the wire of the Anode Cap and make sure the wire is not twisted.
3. Turn over the Rubber Cap. **(Refer to Fig. 1-4.)**

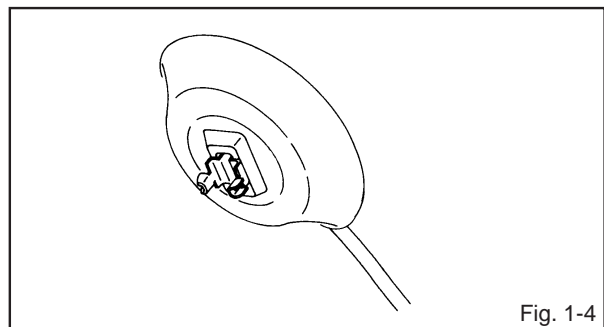

4. Insert one end of the Anode Support into the anode button, then the other as shown in Fig. 1-5.

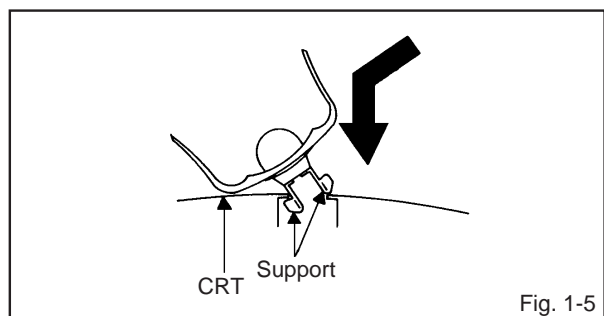

5. Confirm that the Support is securely connected.
6. Put on the Rubber Cap without moving any parts.

# DISASSEMBLY INSTRUCTIONS

## 2. REMOVAL AND INSTALLATION OF FLAT PACKAGE IC

### REMOVAL

1. Put the Masking Tape (cotton tape) around the Flat Package IC to protect other parts from any damage. (Refer to Fig. 2-1.)

#### NOTE

Masking is carried out on all the parts located within 10 mm distance from IC leads.

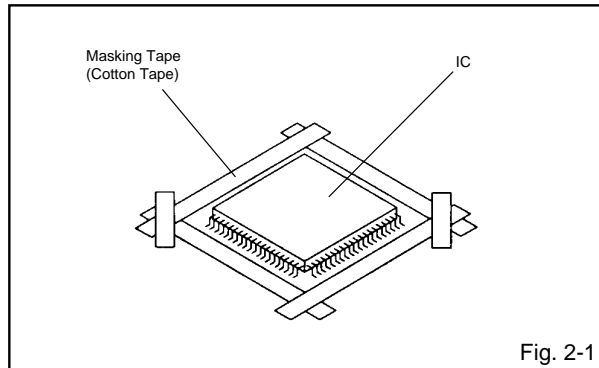

2. Heat the IC leads using a blower type IC desoldering machine. (Refer to Fig. 2-2.)

#### NOTE

Do not add the rotating and the back and forth directions force on the IC, until IC can move back and forth easily after desoldering the IC leads completely.

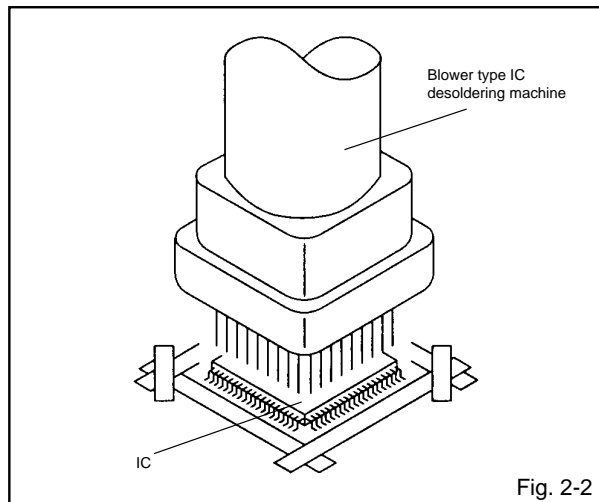

3. When IC starts moving back and forth easily after desoldering completely, pickup the corner of the IC using a tweezers and remove the IC by moving with the IC desoldering machine. (Refer to Fig. 2-3.)

#### NOTE

Some ICs on the PCB are affixed with glue, so be careful not to break or damage the foil of each IC leads or solder lands under the IC when removing it.

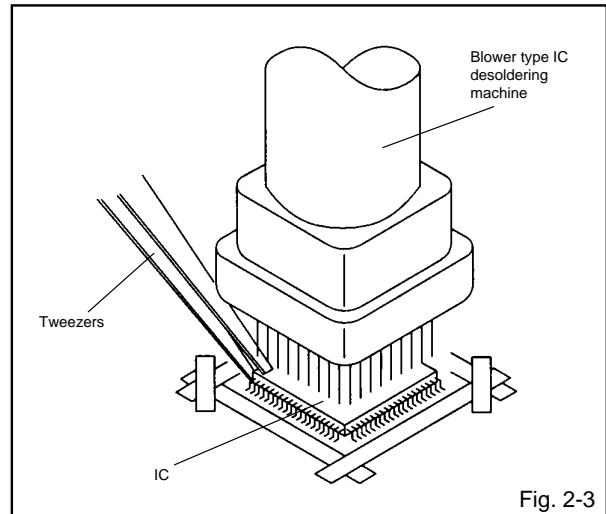

4. Peel off the Masking Tape.

5. Absorb the solder left on the pattern using the Braided Shield Wire. (Refer to Fig. 2-4.)

#### NOTE

Do not move the Braided Shield Wire in the vertical direction towards the IC pattern.

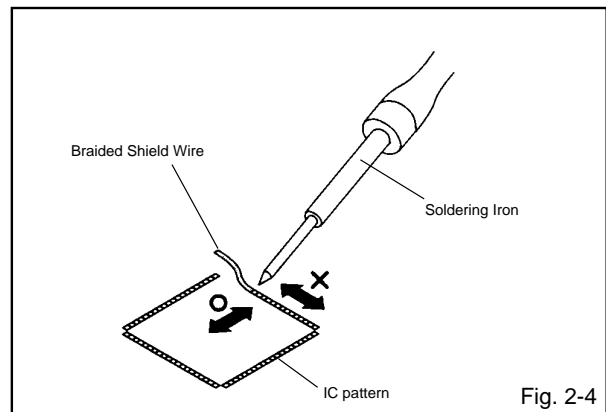

# DISASSEMBLY INSTRUCTIONS

## INSTALLATION

1. Take care of the polarity of new IC and then install the new IC fitting on the printed circuit pattern. Then solder each lead on the diagonal positions of IC temporarily. (Refer to Fig. 2-5.)

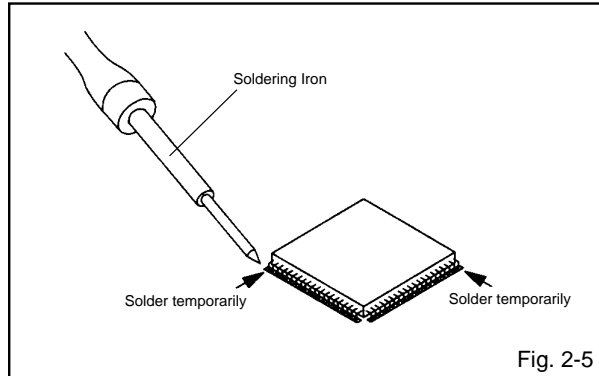

2. Supply the solder from the upper position of IC leads sliding to the lower position of the IC leads. (Refer to Fig. 2-6.)

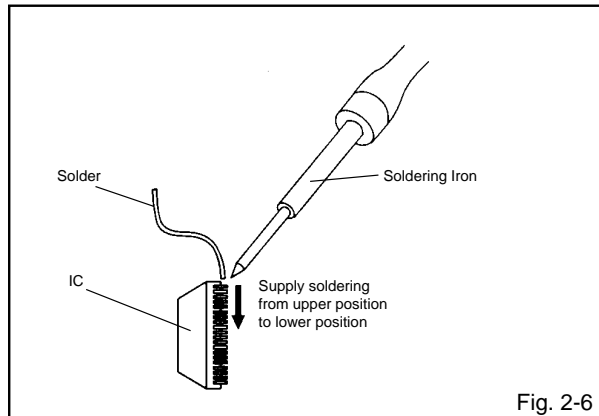

3. Absorb the solder left on the lead using the Braided Shield Wire. (Refer to Fig. 2-7.)

### NOTE

Do not absorb the solder to excess.

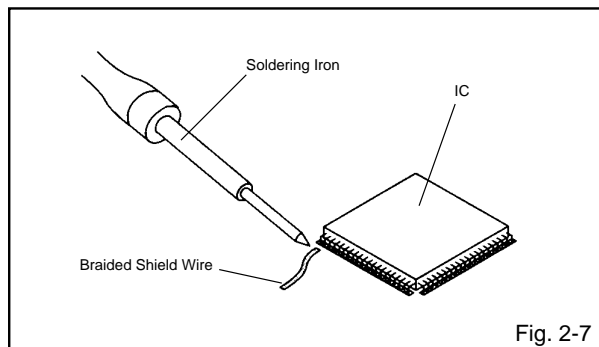

4. When bridge-soldering between terminals and/or the soldering amount are not enough, resolder using a Thin-tip Soldering Iron. (Refer to Fig. 2-8.)

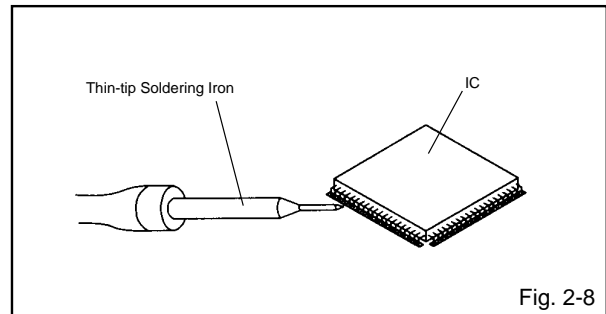

5. Finally, confirm the soldering status on four sides of the IC using a magnifying glass. Confirm that no abnormality is found on the soldering position and installation position of the parts around the IC. If some abnormality is found, correct by resoldering.

### NOTE

When the IC leads are bent during soldering and/or repairing, do not repair the bending of leads. If the bending of leads are repaired, the pattern may be damaged. So, be always sure to replace the IC in this case.

## SERVICE MODE LIST

This unit provided with the following SERVICE MODES so you can repair, examine and adjust easily. To enter the Service Mode, press both set key and remote control key for more than 1 second.

Set Key	Remocon Key	Operations
VOL. (-) MIN	0	Releasing of V-CHIP PASSWORD.
VOL. (-) MIN	1	Initialization of the factory. NOTE: Do not use this for the normal servicing.
VOL. (-) MIN	6	POWER ON total hours is displayed on the screen. Refer to the "CONFIRMATION OF USING HOURS".  Can be checked of the INITIAL DATA of MEMORY IC. Refer to the "NOTE FOR THE REPLACING OF MEMORY IC".
VOL. (-) MIN	8	Writing of EEPROM initial data. NOTE: Do not use this for the normal servicing.
VOL. (-) MIN	9	Display of the Adjustment MENU on the screen. Refer to the "ELECTRICAL ADJUSTMENT" (On-Screen Display Adjustment).

### CONFIRMATION OF USING HOURS

POWER ON total hours can be checked on the screen. Total hours are displayed in 16 system of notation.

1. Set the VOLUME to minimum.
2. Press both VOL. DOWN button on the set and Channel button (6) on the remote control for more than 1 second.
3. After the confirmation of using hours, turn off the power.

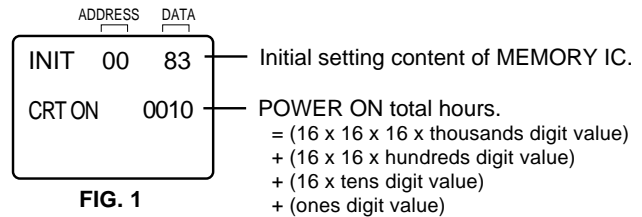

### NOTE FOR THE REPLACING OF MEMORY IC

If a service repair is undertaken where it has been required to change the MEMORY IC, the following steps should be taken to ensure correct data settings while making reference to TABLE 1.

INI	+0	+1	+2	+3	+4	+5	+6	+7	+8	+9	+A	+B	+C	+D	+E	+F
00	E1	C3	CF	00	31	B3	27	17	BB	A8	F4	44	00	00	00	4A
10	0F	---	---	---	---	---	---	---	---	---	---	---	---	---	---	---

**Table 1**

1. Enter DATA SET mode by setting VOLUME to minimum.
2. Press both VOL. DOWN button on the set and Channel button (6) on the remote control for more than 1 second. ADDRESS and DATA should appear as FIG 1.
3. ADDRESS is now selected and should "blink". Using the VOL. UP/DOWN button on the remote, step through the ADDRESS until required ADDRESS to be changed is reached.
4. Press ENTER to select DATA. When DATA is selected, it will "blink".
5. Again, step through the DATA using VOL. UP/DOWN button until required DATA value has been selected.
6. Pressing ENTER will take you back to ADDRESS for further selection if necessary.
7. Repeat steps 3 to 6 until all data has been checked.
8. When satisfied correct DATA has been entered, turn POWER off (return to STANDBY MODE) to finish DATA input. The unit will now have the correct DATA for the new MEMORY IC.

# ELECTRICAL ADJUSTMENTS

## 1. BEFORE MAKING ELECTRICAL ADJUSTMENTS

Read and perform these adjustments when repairing the circuits or replacing electrical parts or PCB assemblies.

### CAUTION

- Use an isolation transformer when performing any service on this chassis.
- Before removing the anode cap, discharge electricity because it contains high voltage.
- When removing a PCB or related component, after unfastening or changing a wire, be sure to put the wire back in its original position.  
Inferior silicon grease can damage IC's and transistors.
- When replacing IC's and transistors, use only specified silicon grease.  
Remove all old silicon before applying new silicon.

Prepare the following measurement tools for electrical adjustments.

1. Oscilloscope
2. Digital Voltmeter

### On-Screen Display Adjustment

1. In the condition of NO indication on the screen.  
Press the VOL. DOWN button on the set and the Channel button (9) on the remote control for more than 1 second to appear the adjustment mode on the screen as shown in Fig. 1-1.

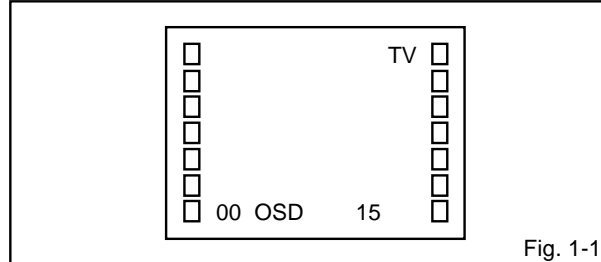

Fig. 1-1

2. Use the Channel UP/DOWN button or Channel button (0-9) on the remote control to select the options shown in Fig. 1-2.
3. Press the MENU button on the remote control to end the adjustments.

NO.	FUNCTION	NO.	FUNCTION
00	OSD H	17	SUBCONT
01	CUT OFF	18	UNI COL
02	RF. AGC	19	---
03	---	20	TINT
04	H. POSI	21	SHARP
05	V. POSI	22	RGB CONT
06	H. SIZE	23	PARABOLA
07	V. SIZE	24	TRAPEZIU
08	V. CENT	25	COR TOP
09	V. LIN	26	COR BTM
10	VS. CORR	27	V EHT
11	G. DRV	28	H EHT
12	B. DRV	29	FM. LVL
13	R. BIAS	30	LEVEL
14	G. BIAS	31	SEP1
15	B. BIAS	32	SEP2
16	BRI	33	T. STE

Fig. 1-2

## 2. BASIC ADJUSTMENTS

### 2-1: CONSTANT VOLTAGE

1. Set condition is AV MODE without signal.
2. Connect the digital voltmeter to TP002.
3. Adjust the VR502 until the digital voltmeter is  $115 \pm 1V$ .

### 2-2: RF AGC

1. Receive a 70dB monoscope pattern.
2. Connect the digital voltmeter between the TP001 and the GND.
3. Activate the adjustment mode display of Fig. 1-1 and press the channel button (02) on the remote control to select "RF. AGC".
4. Press the VOL. UP/DOWN button on the remote control until the digital voltmeter is  $1.95 \pm 0.05V$ .

### 2-3: CUT OFF

1. Adjust the unit to the following settings.  
G. DRIVE=64, B. DRIVE=64, R. BIAS=32, G. BIAS=32, B. BIAS=32, BRIGHTNESS=64, UNI COLOR=50.
2. Place the set with Aging Test for more than 15 minutes.
3. Activate the adjustment mode display of Fig. 1-1 and press the channel button (01) on the remote control to select "CUT OFF".
4. Adjust the Screen Volume until a dim raster is obtained.

### 2-4: WHITE BALANCE

**NOTE:** Adjust after performing CUT OFF adjustment.

1. Place the set with Aging Test for more than 10 minutes.
2. Receive the white 100% signal from the Pattern Generator.
3. Using the adjustment control, set the brightness and contrast to normal position.
4. Activate the adjustment mode display of Fig. 1-1 and press the channel button (13) on the remote control to select "R. BIAS".
5. Using the VOL. UP/DOWN button on the remote control, adjust the R. BIAS.
6. Press the CH. UP/DOWN button on the remote control to select the "G. DRV", "B. DRV", "G. BIAS" or "B. BIAS".
7. Using the VOL. UP/DOWN button on the remote control, adjust the G. DRV, B. DRV, G. BIAS or B. BIAS.
8. Perform the above adjustments 6 and 7 until the white color is looked like a white.

### 2-5: FOCUS

1. Receive a 70dB monoscope pattern.
2. Turn the Focus Volume fully counterclockwise once.
3. Adjust the Focus Volume until picture is distinct.

### 2-6: HORIZONTAL POSITION

1. Receive the center cross signal from the Pattern Generator.
2. Using the remote control, set the brightness and contrast to normal position.
3. Activate the adjustment mode display of Fig. 1-1 and press the channel button (04) on the remote control to select "H. POSI".
4. Press the VOL. UP/DOWN button on the remote control until the right and left screen size of the vertical line becomes the same.

# ELECTRICAL ADJUSTMENTS

## 2-7: HORIZONTAL SIZE

**NOTE:** Adjust after performing adjustments in section 2-6.

1. Receive the monoscope pattern.
2. Using the remote control, set the brightness and contrast to normal position.
3. Activate the adjustment mode display of **Fig. 1-1** and press the channel button **(06)** on the remote control to select "H. SIZE".
4. Press the VOL. UP/DOWN button on the remote control until the SHIFT quantity of the OVER SCAN on right and left becomes  $10 \pm 2\%$ .

## 2-8: VERTICAL POSITION

**NOTE:** Adjust after performing adjustments in section 2-7.

1. Receive the center cross signal from the Pattern Generator.
2. Activate the adjustment mode display of **Fig. 1-1** and press the channel button **(05)** on the remote control to select "V. POSI".
3. Press the VOL. UP/DOWN button on the remote control until the horizontal line becomes fit to the notch of the shadow mask.

## 2-9: VERTICAL SIZE

**NOTE:** Adjust after performing adjustments in section 2-8.

1. Receive the crosshatch signal from the Pattern Generator.
2. Activate the adjustment mode display of **Fig. 1-1** and press the channel button **(07)** on the remote control to select "V. SIZE".
3. Press the VOL. UP/DOWN button on the remote control until the rectangle on the center of the screen becomes square.
4. Receive a broadcast and check if the picture is normal.

## 2-10: PARABOLA

1. Receive the crosshatch signal from the Pattern Generator.
2. Using the remote control, set the brightness and contrast to normal position.
3. Activate the adjustment mode display of **Fig. 1-1** and press the channel button **(23)** on the remote control to select "PARABOLA".
4. Press the VOL. UP/DOWN button on the remote control until the right and left vertical lines are straight.

## 2-11: TRAPEZIUM

1. Receive the crosshatch signal from the Pattern Generator.
2. Using the remote control, set the brightness and contrast to normal position.
3. Activate the adjustment mode display of **Fig. 1-1** and press the channel button **(24)** on the remote control to select "TRAPEZIU".
4. Press the VOL. UP/DOWN button on the remote control until the both vertical lines of the screen become parallel.

## 2-12: CORNER CORR TOP

1. Receive the crosshatch signal from the Pattern Generator.
2. Using the remote control, set the brightness and contrast to normal position.
3. Activate the adjustment mode display of **Fig. 1-1** and press the channel button **(25)** on the remote control to select "COR TOP".
4. Press the VOL. UP/DOWN button on the remote control until the upper section of the both ends vertical lines are straight.

## 2-13: CORNER CORR BOTTOM

1. Receive the crosshatch signal from the Pattern Generator.
2. Using the remote control, set the brightness and contrast to normal position.
3. Activate the adjustment mode display of **Fig. 1-1** and press the channel button **(26)** on the remote control to select "COR BTM".
4. Press the VOL. UP/DOWN button on the remote control until the bottom section of the both ends vertical lines are straight.

## 2-14: OSD HORIZONTAL

1. Activate the adjustment mode display of **Fig. 1-1**.
2. Press the VOL. UP/DOWN button on the remote control until the difference of A and B becomes minimum. (**Refer to Fig. 2-1**)

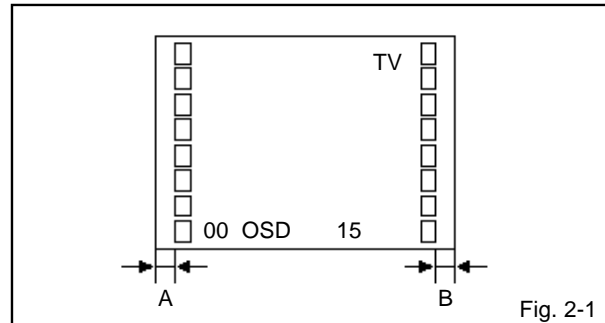

Fig. 2-1

## 2-15: LEVEL

1. Receive a 70dB monoscope pattern.
2. Connect the AC voltmeter to **TP901**.
3. Activate the adjustment mode display of **Fig. 1-1** and press the channel button **(30)** on the remote control to select "LEVEL".
4. Press the VOL. UP/DOWN button on the remote control until the AC voltmeter is  $75 \pm 2mV$ .

## ELECTRICAL ADJUSTMENTS

### 2-16: SEPARATION 1, 2

1. Receive the stereo signal (L=2KHz, R=400Hz).
2. Connect the AC voltmeter to **AUDIO OUT JACK** through stereo filter (L=400Hz, R=2KHz).
3. Activate the adjustment mode display of **Fig. 1-1** and press the channel button **(31)** on the remote control to select "SEP1".
4. Press the VOL. UP/DOWN button on the remote control until the output of L-CH and R-CH become minimum.
5. Press the CH UP button once the set to "SEP2" mode.
6. Press the VOL. UP/DOWN button on the remote control until the output of L-CH and R-CH become minimum.
7. Press the CH DOWN button once the set to "SEP1" mode.
8. Repeat step 4 to step 7 several times.  
The output difference of the between with Filter and without Filter should be more than 25db for both L and R.

### 2-17: BRIGHTNESS

1. Activate the adjustment mode display of **Fig. 1-1** and press the channel button **(16)** on the remote control to select "BRI".
2. Press the VOL. UP/DOWN button on the remote control until the brightness step No. becomes "68"
3. Press the TV/VIDEO button on the remote control to set to the AV mode. Then perform the above adjustments 1~2.
4. Press the TV/VIDEO button on the remote control to set to the CS mode. Then perform the above adjustments 1~2.

### 2-18: UNI-COLOR

1. Activate the adjustment mode display of **Fig. 1-1** and press the channel button **(18)** on the remote control to select "UNI COL".
2. Press the VOL. UP/DOWN button on the remote control until the contrast step No. becomes "49"
3. Press the TV/VIDEO button on the remote control to set to the AV mode.
4. Activate the adjustment mode display of **Fig. 1-1** and press the channel button **(18)** on the remote control to select "UNI COL".
5. Press the VOL. UP/DOWN button on the remote control until the contrast step No. becomes "49"
6. Press the TV/VIDEO button on the remote control to set to the CS mode. Then perform the above adjustments 4~5.

### 2-19: SUB TINT/SUB COLOR

1. Receive the color bar pattern. (RF Input)
2. Connect the oscilloscope to **TP806**.
3. Activate the adjustment mode display of **Fig. 1-1** and press the channel button **(20)** on the remote control to select "TINT".
4. Press the VOL. UP/DOWN button on the remote control until the section "A" becomes a straight line **(Refer Fig. 2-2)**.
5. Connect the oscilloscope to **TP804**.
6. Press the CH DOWN button 3 times to set to "SUBCONT" mode.
7. Press the VOL. UP/DOWN button on the remote control until the red color level is adjusted to 100% of the white level. **(Refer to Fig. 2-3)**
8. Receive the color bar pattern. (Audio Video Input)
9. Press the TV/VIDEO button on the remote control to set to the AV mode. Then perform the above adjustments 2~7.
10. Receive the color bar pattern. (Audio Video Input)
11. Press the TV/VIDEO button on the remote control to set to the CS mode. Then perform the above adjustments 2~6.
12. Press the VOL. UP/DOWN button on the remote control until the red color level is adjusted to 100% of the white level. **(Refer to Fig. 2-3)**

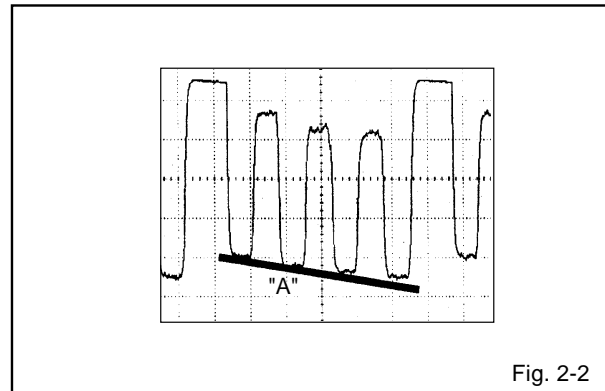

Fig. 2-2

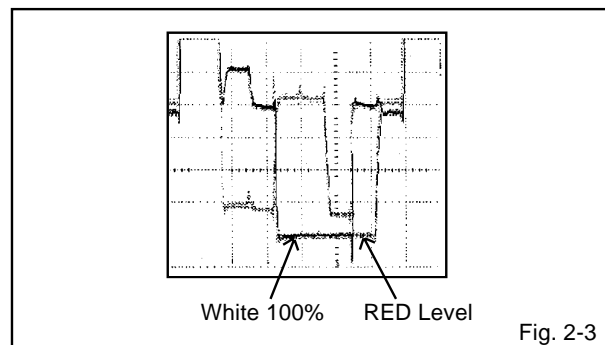

Fig. 2-3

# ELECTRICAL ADJUSTMENTS

## 3. PURITY AND CONVERGENCE ADJUSTMENTS

### NOTE

1. Turn the unit on and let it warm up for at least 30 minutes before performing the following adjustments.
2. Place the CRT surface facing east or west to reduce the terrestrial magnetism.
3. Turn ON the unit and demagnetize with a Degauss Coil.

### 3-1: STATIC CONVERGENCE (ROUGH ADJUSTMENT)

1. Tighten the screw for the magnet. Refer to the adjusted CRT for the position. **(Refer to Fig. 3-1)**  
If the deflection yoke and magnet are in one body, untighten the screw for the body.
2. Receive the green raster pattern from the color bar generator.
3. Slide the deflection yoke until it touches the funnel side of the CRT.
4. Adjust center of screen to green, with red and blue on the sides, using the pair of purity magnets.
5. Switch the color bar generator from the green raster pattern to the crosshatch pattern.
6. Combine red and blue of the 3 color crosshatch pattern on the center of the screen by adjusting the pair of 4 pole magnets.
7. Combine red/blue (magenta) and green by adjusting the pair of 6 pole magnets.
8. Adjust the crosshatch pattern to change to white by repeating steps 6 and 7.

### 3-2: PURITY

#### NOTE

Adjust after performing adjustments in section 3-1.

1. Receive the green raster pattern from color bar generator.
2. Adjust the pair of purity magnets to center the color on the screen.  
Adjust the pair of purity magnets so the color at the ends are equally wide.
3. Move the deflection yoke backward (to neck side) slowly, and stop it at the position when the whole screen is green.
4. Confirm red and blue colors.
5. Adjust the slant of the deflection yoke while watching the screen, then tighten the fixing screw.

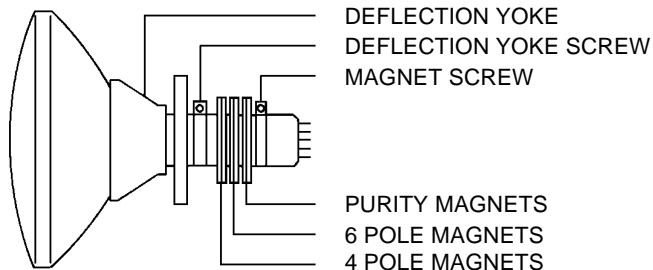

Fig. 3-1

### 3-3: STATIC CONVERGENCE

#### NOTE

Adjust after performing adjustments in section 3-2.

1. Receive the crosshatch pattern from the color bar generator.
2. Combine red and blue of the 3 color crosshatch pattern on the center of the screen by adjusting the pair of 4 pole magnets.
3. Combine red/blue (magenta) and green by adjusting the pair of 6 pole magnets.

### 3-4: DYNAMIC CONVERGENCE

#### NOTE

Adjust after performing adjustments in section 3-3.

1. Adjust the differences around the screen by moving the deflection yoke upward/downward and right/left. **(Refer to Fig. 3-2-a)**
2. Insert three wedges between the deflection yoke and CRT funnel to fix the deflection yoke. **(Refer to Fig. 3-2-b)**

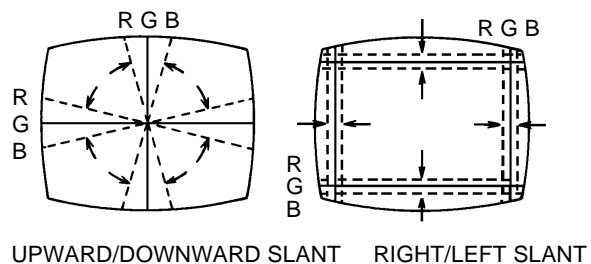

Fig. 3-2-a

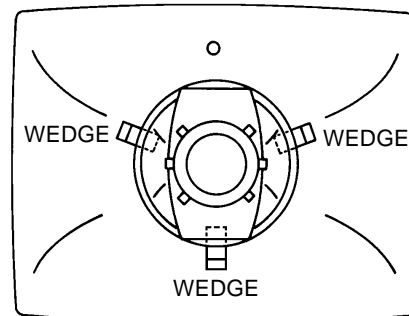
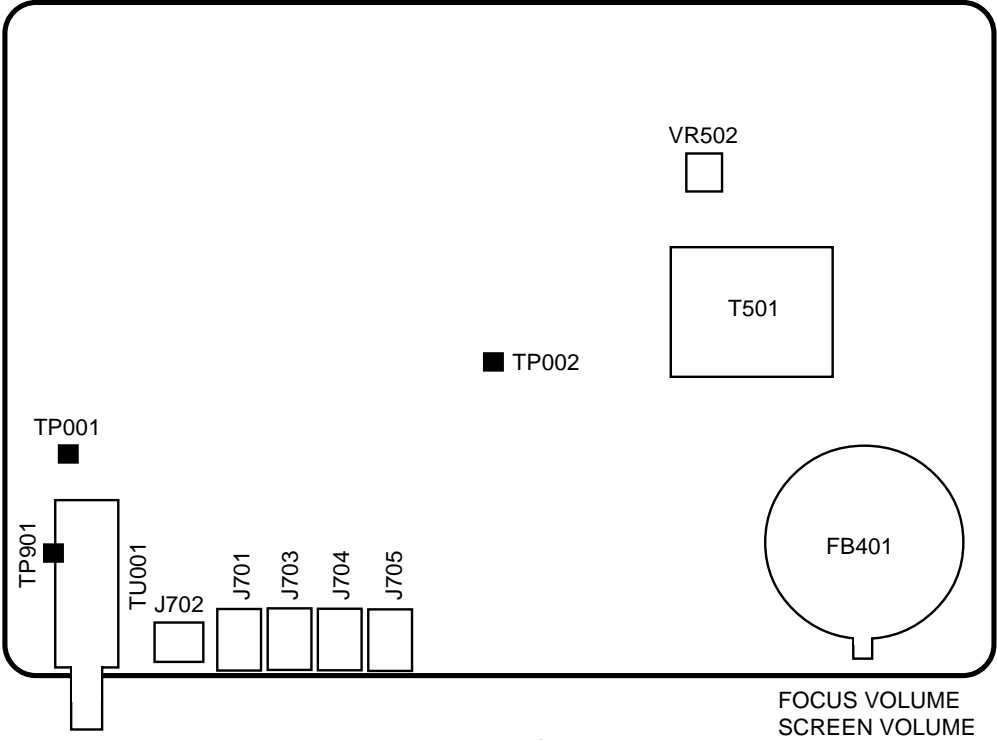
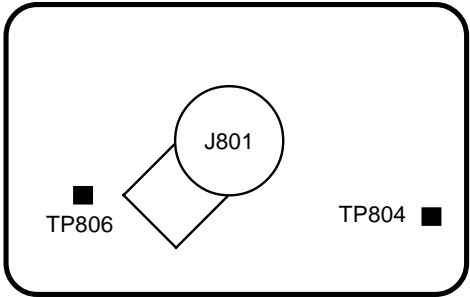

Fig. 3-2-b

# MAJOR COMPONENTS LOCATION GUIDE



**MAIN PCB**



**CRT PCB**

### BLOCK DIAGRAM

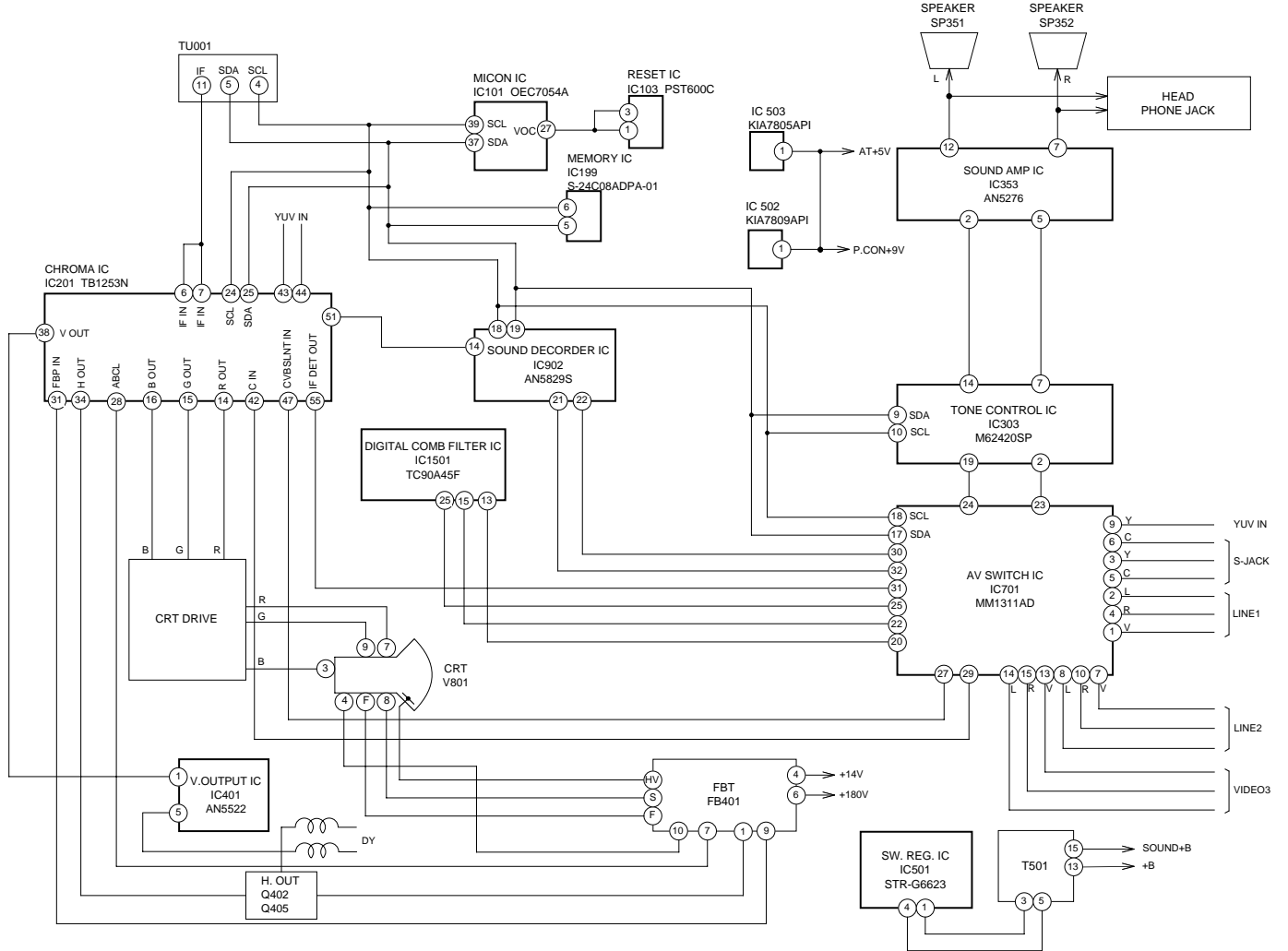





PRINTED CIRCUIT BOARDS  
MAIN (CHIP MOUNTED PARTS)  
SOLDER SIDE

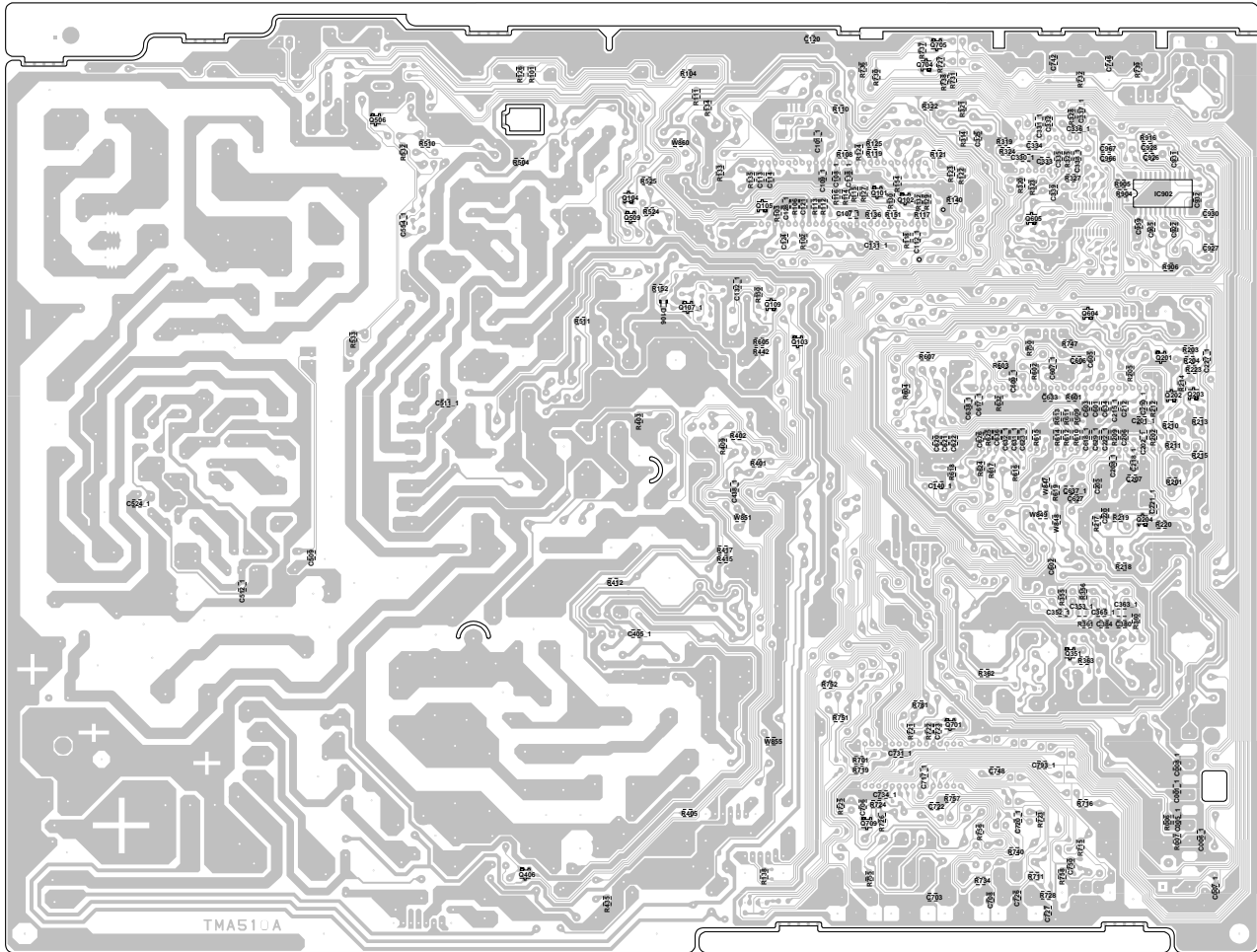

TMA510A

# MICON/TUNER SCHEMATIC DIAGRAM (MAIN PCB)

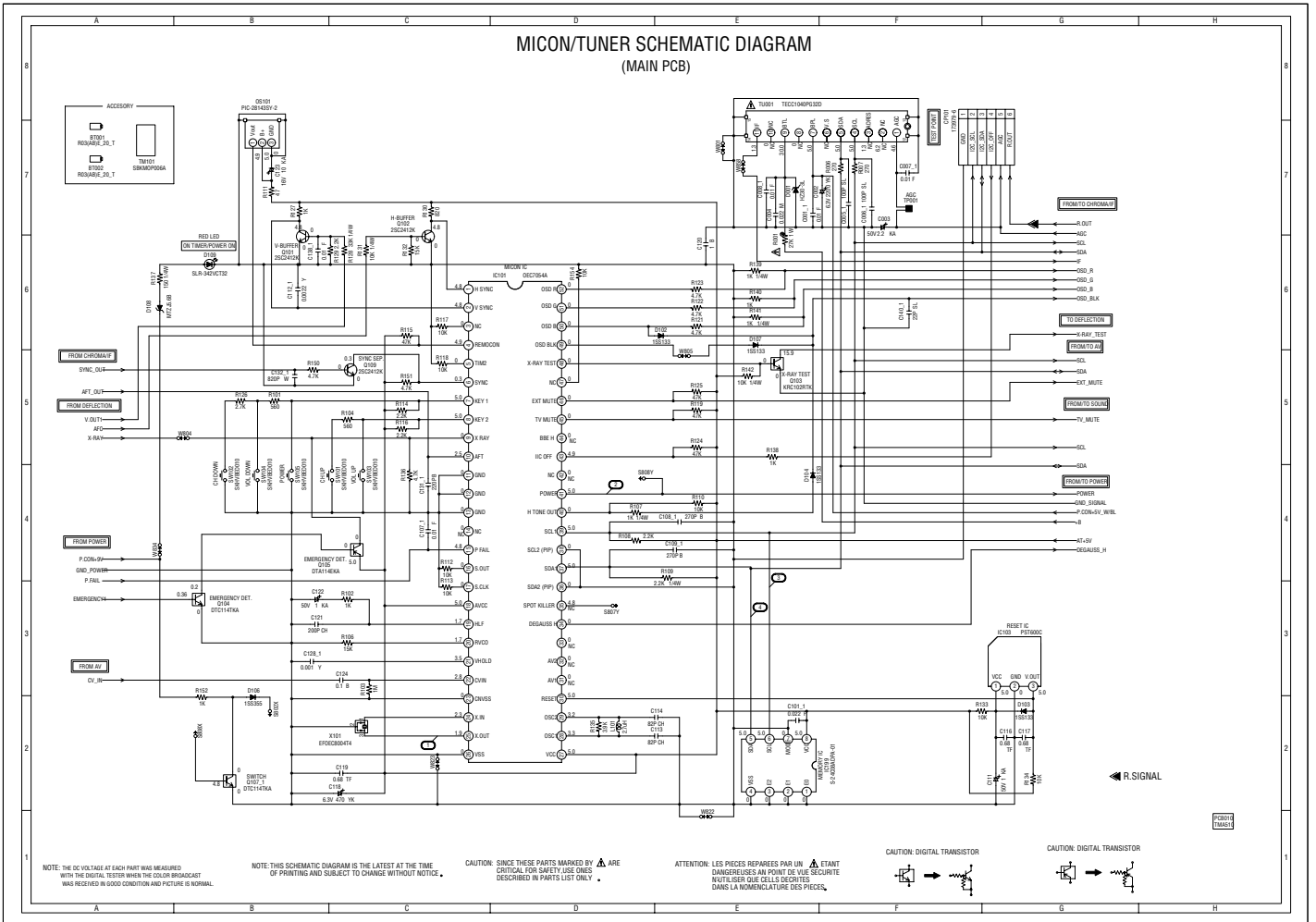

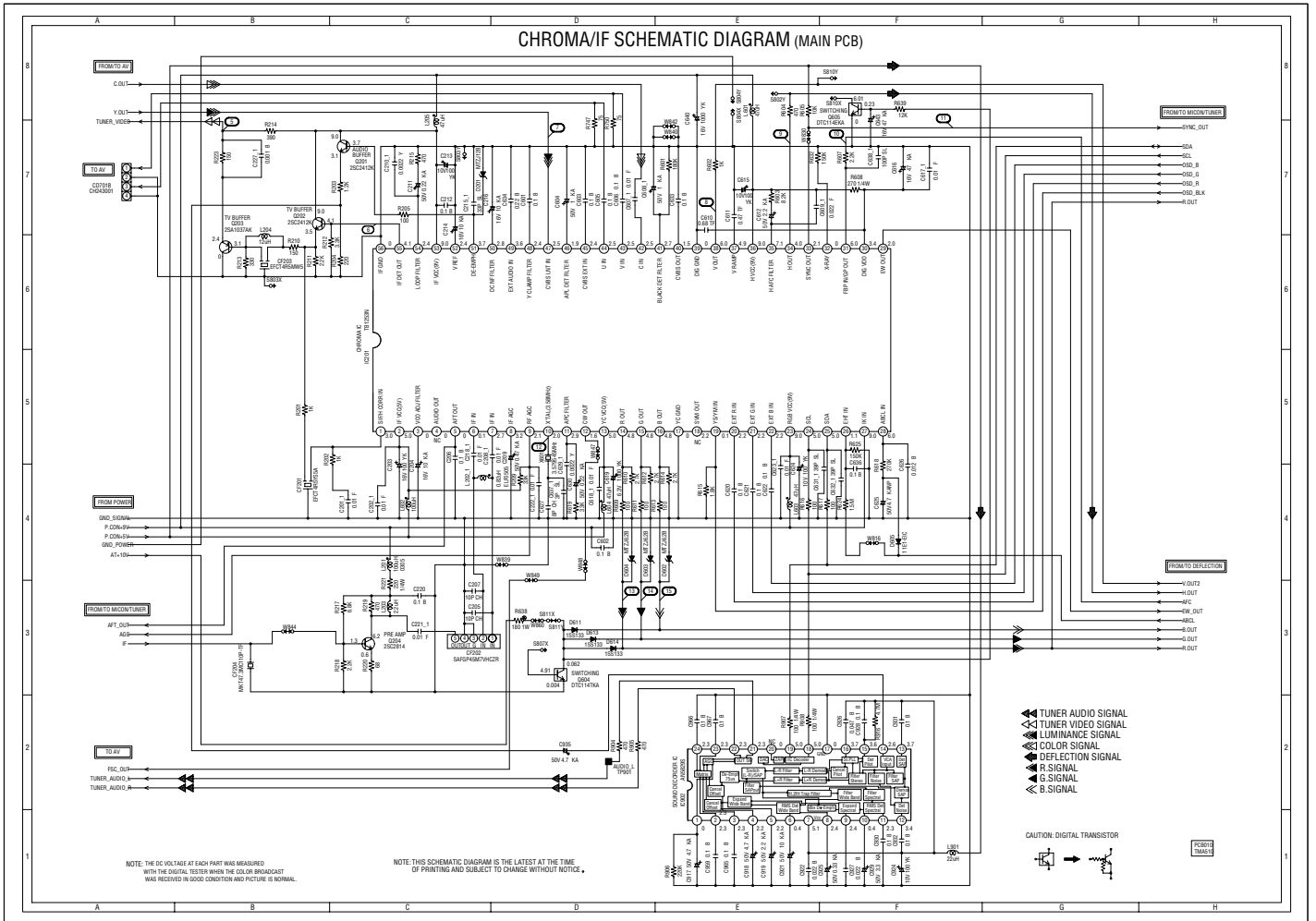

## DEFLECTION SCHEMATIC DIAGRAM (MAIN PCB)

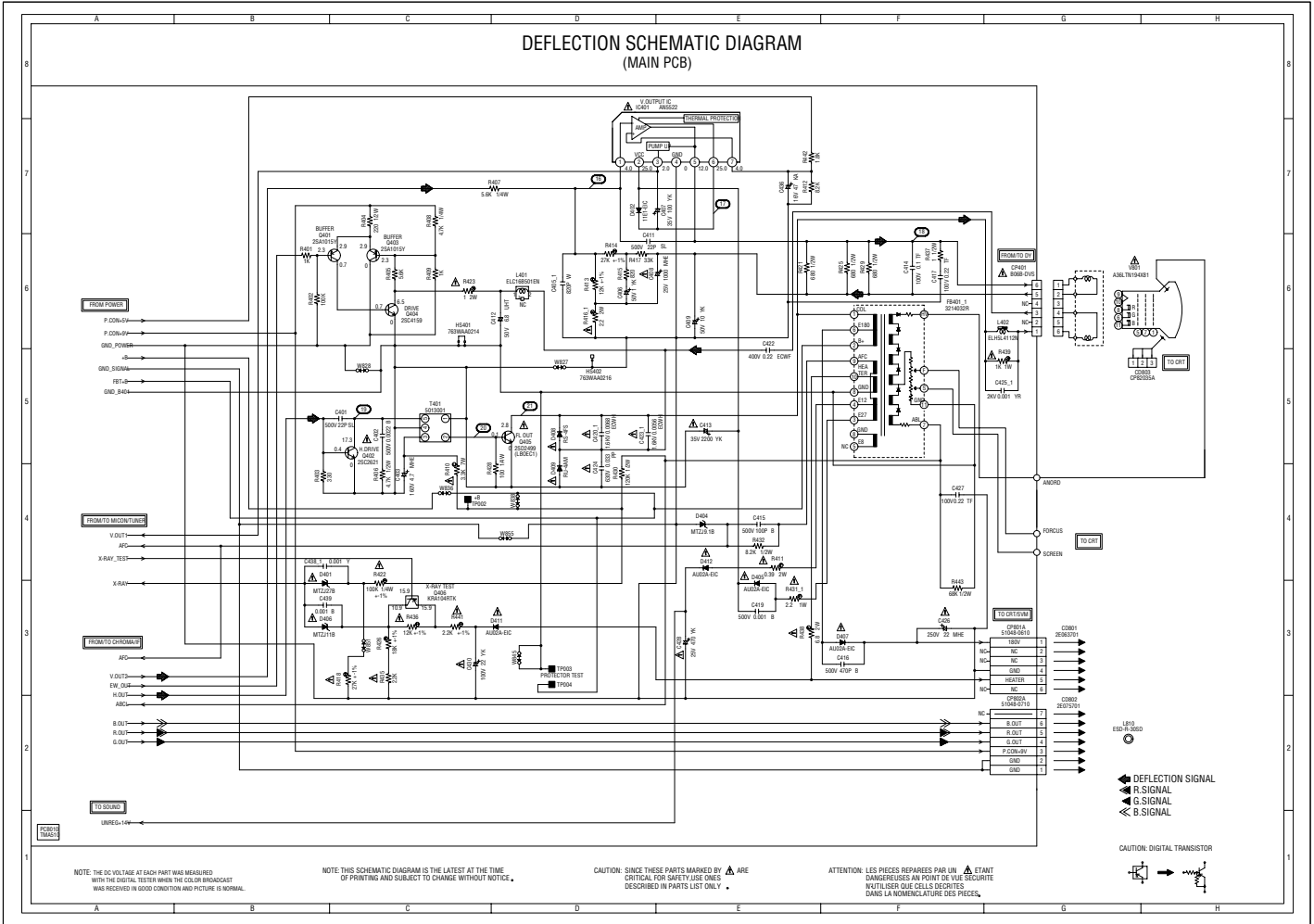

# POWER SCHEMATIC DIAGRAM (MAIN PCB)

**CAUTION:** FOR CONTINUED PROTECTION AGAINST FIRE HAZARD, REPLACE ONLY WITH THE SAME TYPE FUSE 6.3A 125V(F501)

**ATTENTION:** POUR UNE PROTECTION CONTINUE LES RISQUES D'INCENDIE REMPLACEZ SEULEMENT DES FUSIBLES DE MÊME TYPE 6.3A 125V(F501)

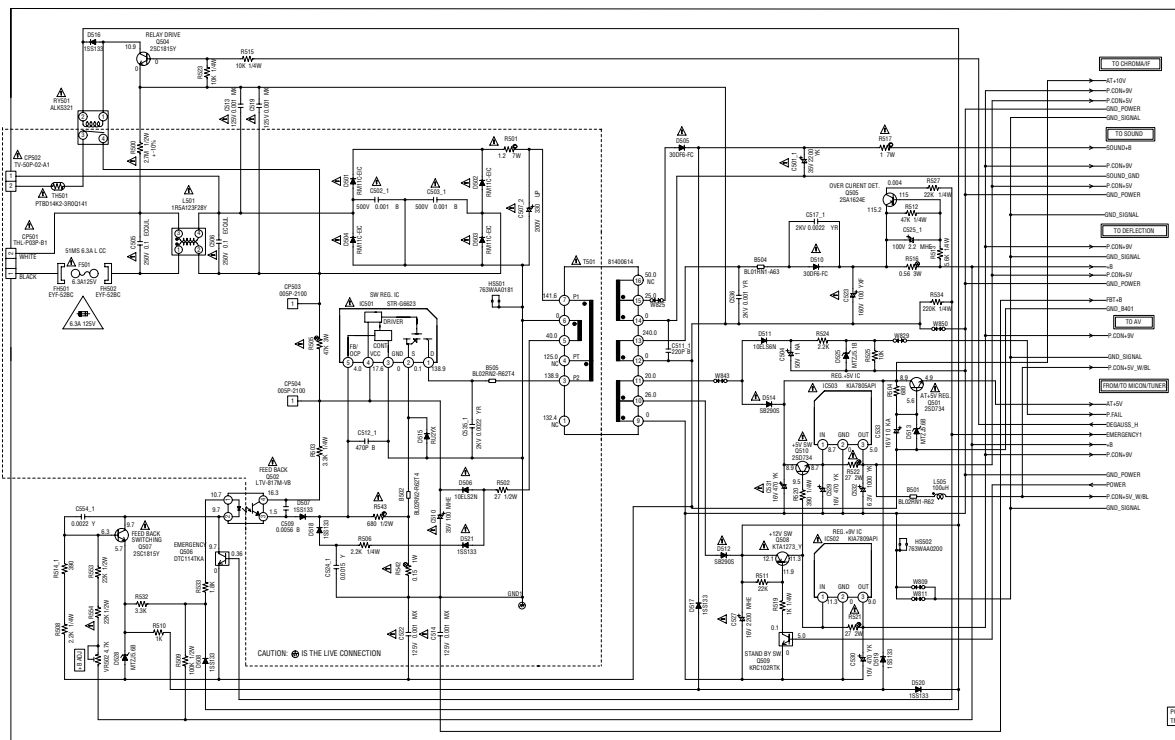

NOTE: THE DC VOLTAGE AT EACH PART WAS MEASURED WITH THE DIGITAL TESTER WHEN THE COLOR BROADCAST WAS RECEIVED IN GOOD CONDITION AND PICTURE IS NORMAL.

NOTE: THIS SCHEMATIC DIAGRAM IS THE LATEST AT THE TIME OF PRINTING AND SUBJECT TO CHANGE WITHOUT NOTICE.

CAUTION: SINCE THESE PARTS MARKED WITH ARE DANGEROUS AN POINT DE VUE SECURITE NEUTRILISER QUE CELLES SECURITES DESCRIBED IN PARTS LIST ONLY.

ATTENTION: LES PIECES REPAREES PAR UN ETANT DANGEREUSES AN POINT DE VUE SECURITE NEUTRILISER QUE CELLES SECURITES DANS LA NOMENCLATURE DES PIECES.

CAUTION: DIGITAL TRANSISTOR

PCB01  
TIM851

### SOUND SCHEMATIC DIAGRAM (MAIN PCB)

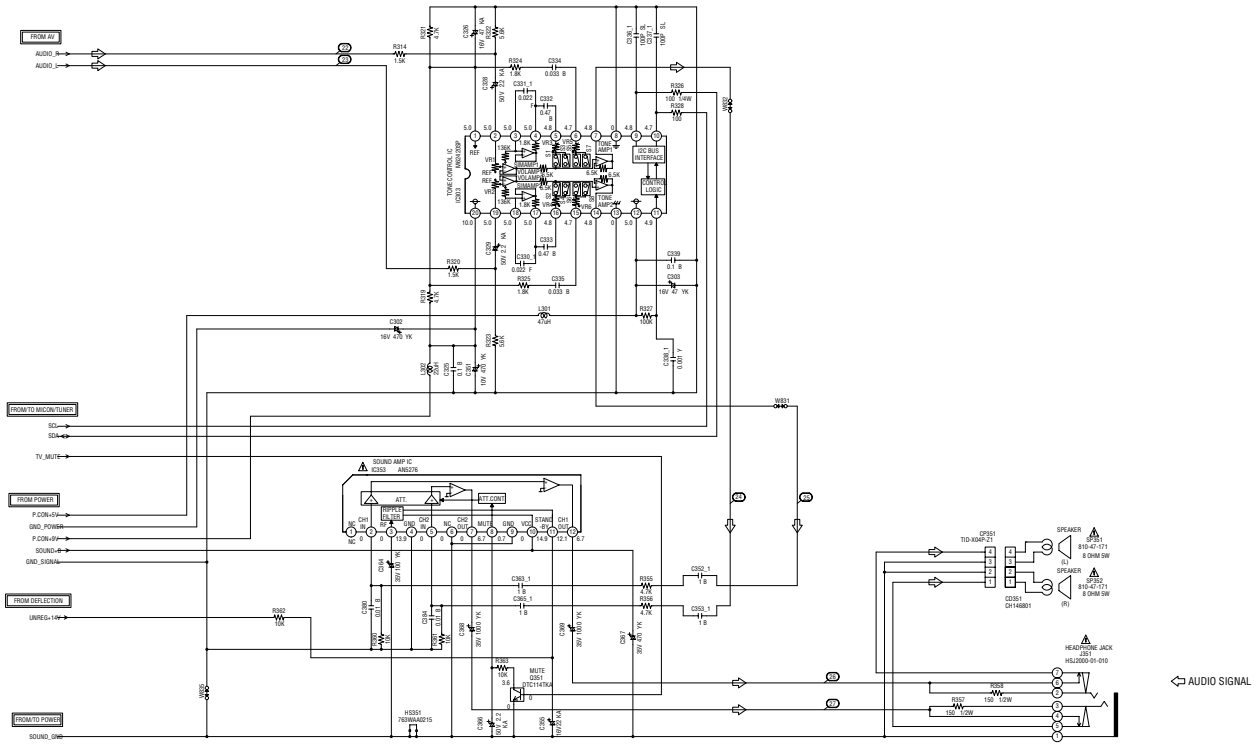

NOTE: THE DC VOLTAGE AT EACH PART WAS MEASURED WITH THE DIGITAL TESTER WHEN THE COLOR SIGNAL WAS RECEIVED IN GOOD CONDITION AND PICTURE IS NORMAL.

NOTE: THIS SCHEMATIC DIAGRAM IS THE LATEST AT THE TIME OF PRINTING AND SUBJECT TO CHANGE WITHOUT NOTICE.

CAUTION: SINCE THESE PARTS MARKED BY ARE CRITICAL FOR SAFETY USE ONES DESCRIBED IN PARTS LIST ONLY.

ATTENTION: LES PIÈCES REPARÉES PAR UN ÉTANT DANGEREUSES À UN POINT DE VUE SÉCURITÉ, UTILISER QUE CELLES DÉCRITES DANS LA NOMÉNCLATURE DES PIÈCES.

CAUTION: DIGITAL TRANSISTOR

PCB71 TMAS13

← AUDIO SIGNAL

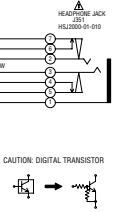

# AV SCHEMATIC DIAGRAM (MAIN PCB)

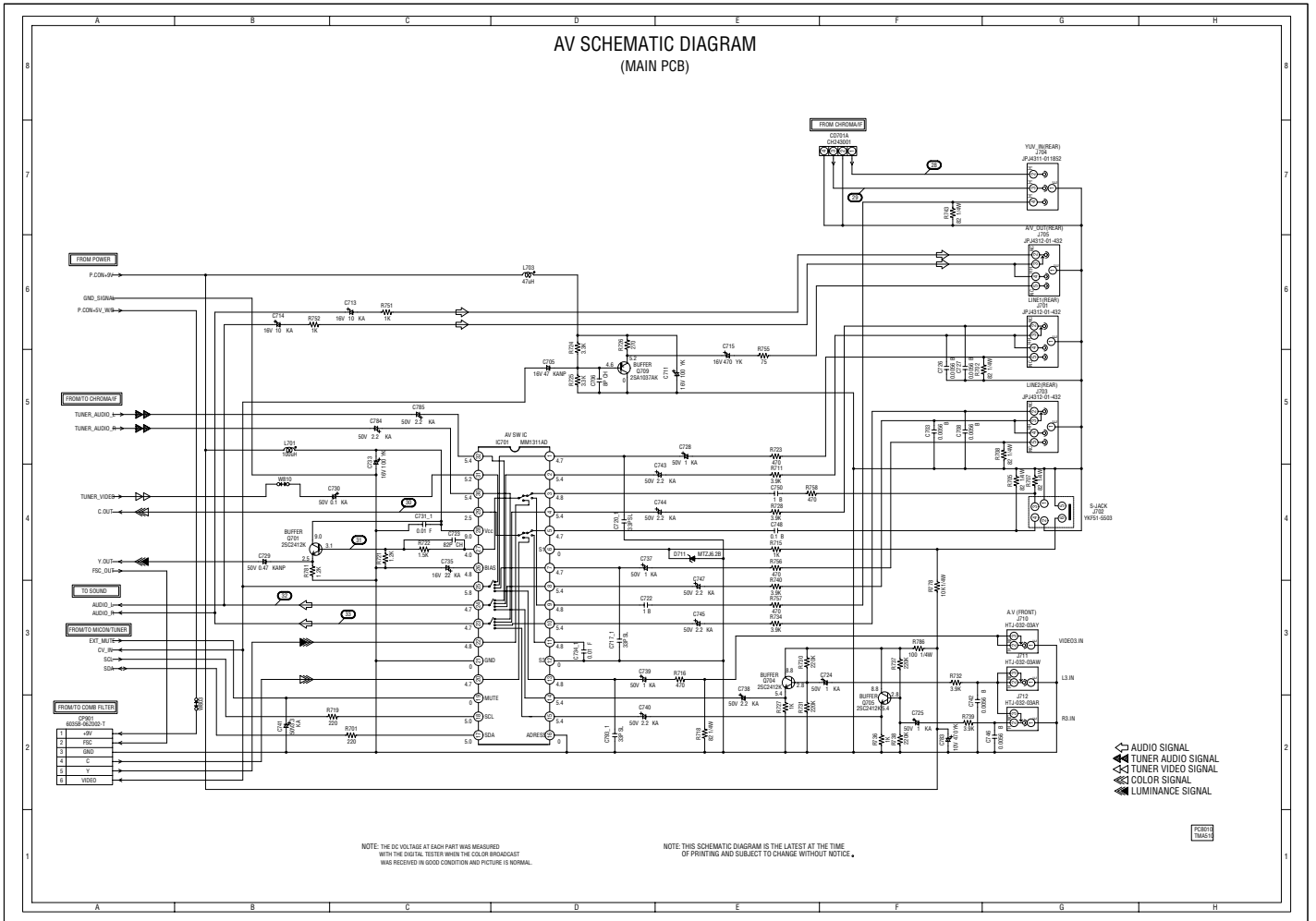

### CRT SCHEMATIC DIAGRAM (CRT PCB)

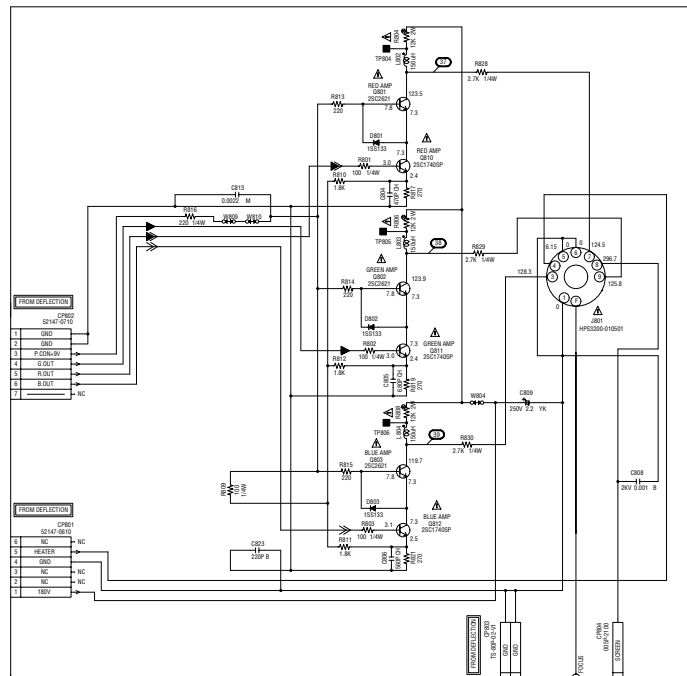

NOTE: THE DC VOLTAGE AT EACH PART WAS MEASURED WITH THE DIGITAL TESTER WHEN THE COLOR BROADCAST WAS RECEIVED IN GOOD CONDITION AND PICTURE IS NORMAL.

NOTE: THIS SCHEMATIC DIAGRAM IS THE LATEST AT THE TIME OF PRINTING AND SUBJECT TO CHANGE WITHOUT NOTICE.

CAUTION: SINCE THESE PARTS MARKED BY ARE CRITICAL FOR SAFETY USE CARE DESCRIBED IN PARTS LIST ONLY.

ATTENTION: LES PIÈCES REPARÉES PAR UN ÉTAIENT DANGEREUSES AN POINT DE VUE SÉCURITÉ. VOTRE TRAVAIL DOIT ÊTRE FAIT EN SÉCURITÉ DANS LA NOMÉCLATURE DES PIÈCES.

◀ R. SIGNAL  
◀ G. SIGNAL  
◀ B. SIGNAL

CR110  
12A30

# DIGITAL COMB FILTER SCHEMATIC DIAGRAM (COMB PCB)

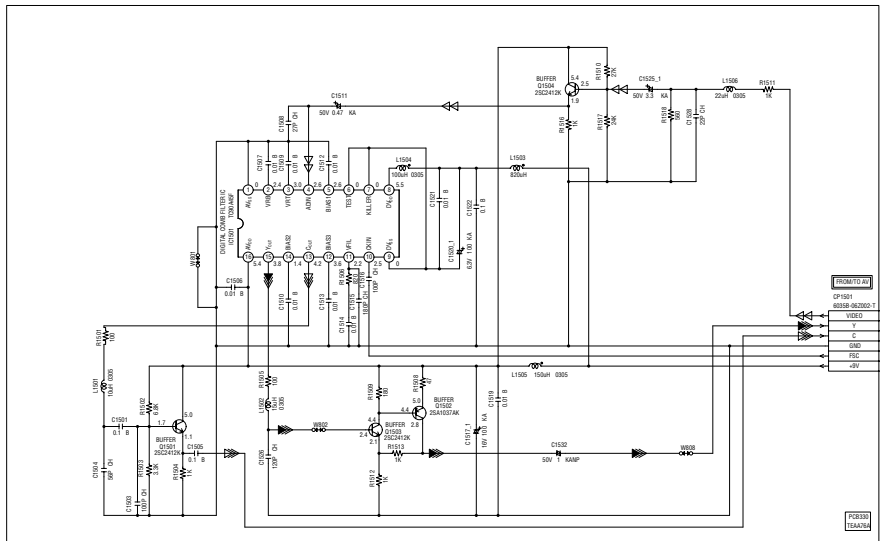

NOTE: THIS SCHEMATIC DIAGRAM IS THE LATEST AT THE TIME OF PRINTING AND SUBJECT TO CHANGE WITHOUT NOTICE.

NOTE: THE DC VOLTAGE AT EACH PART WAS MEASURED WITH THE DIGITAL TESTER WHEN THE COLOR BROADCAST WAS RECEIVED IN GOOD CONDITION AND PICTURE IS NORMAL.

- ◀ RECORD COLOR SIGNAL
- ◀ RECORD LUMINANCE SIGNAL
- ◀ TUNER VIDEO SIGNAL

# WAVEFORMS

## MICON/TUNER

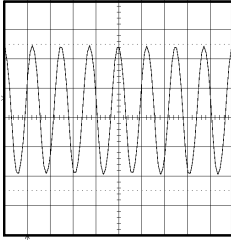

① 1V 0.1 $\mu$ s/div

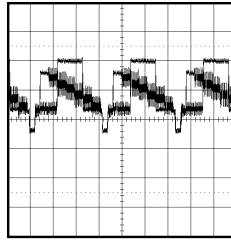

⑥ 1V 20 $\mu$ s/div

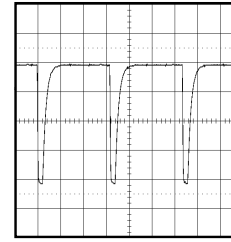

⑪ 0.5V 20 $\mu$ s/div

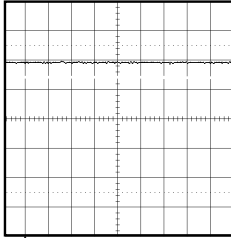

② 1V 1 $\mu$ s/div

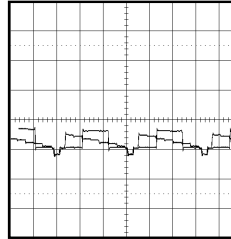

⑦ 1V 20 $\mu$ s/div

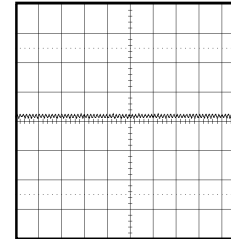

⑫ 1V 2 $\mu$ s/div

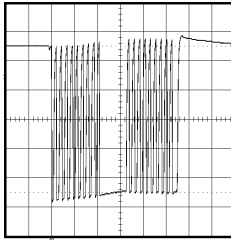

③ 1V 50 $\mu$ s/div

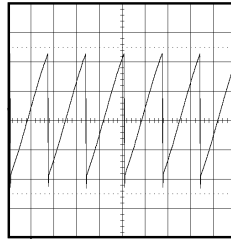

⑧ 0.5V 10ms/div

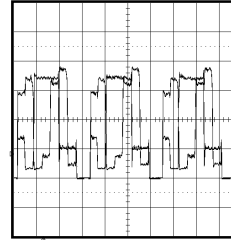

⑬ 1V 20 $\mu$ s/div

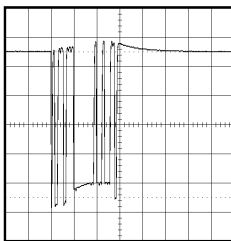

④ 1V 0.1ms/div

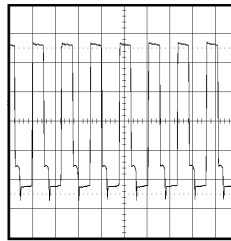

⑨ 1V 50 $\mu$ s/div

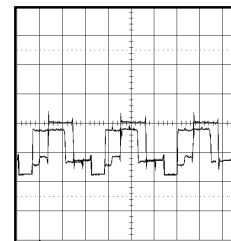

⑭ 2V 20 $\mu$ s/div

## CHROMA/IF

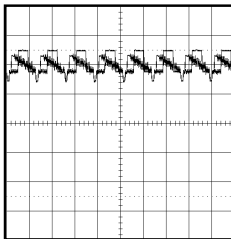

⑤ 1V 50 $\mu$ s/div

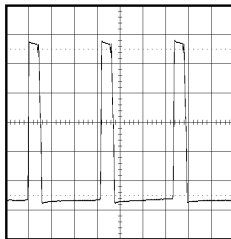

⑩ 2V 20 $\mu$ s/div

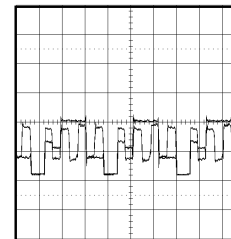

⑮ 2V 20 $\mu$ s/div

NOTE: The following waveforms were measured at the point of the corresponding balloon number in the schematic diagram.

# WAVEFORMS

## DEFLECTION

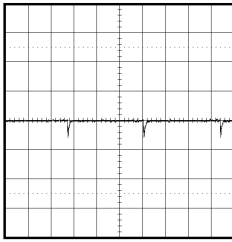

⑩ 2V 5ms/div

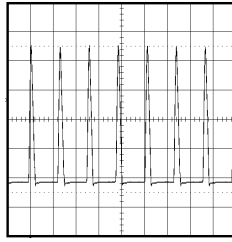

⑪ 200V 50μs/div

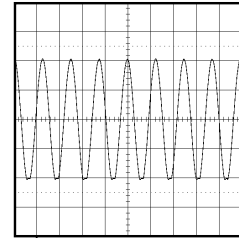

⑫ 5V 2ms/div

## SOUND

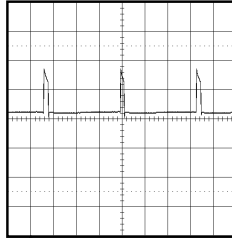

⑬ 20V 5ms/div

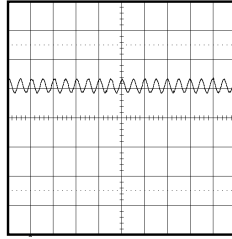

⑭ 2V 5ms/div

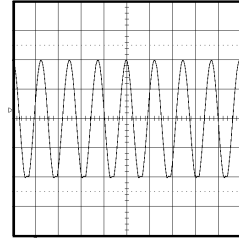

⑮ 5V 2ms/div

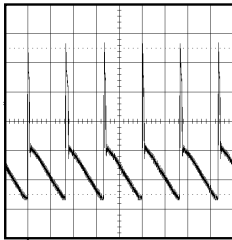

⑯ 10V 10ms/div

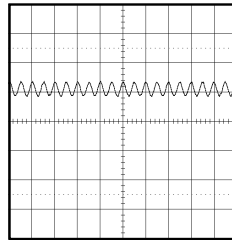

⑰ 2V 5ms/div

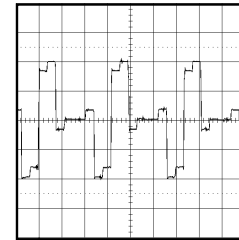

⑱ 200mV 20μs/div

## AV

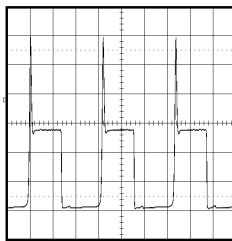

⑲ 20V 20μs/div

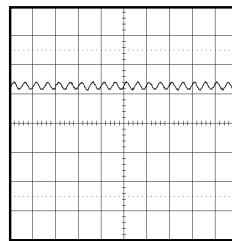

⑳ 2V 5ms/div

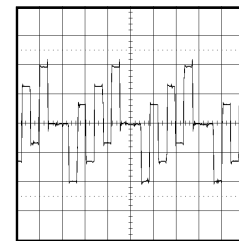

㉑ 200mV 20μs/div

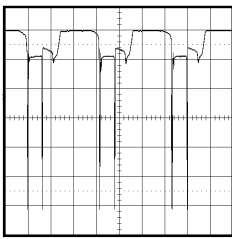

㉒ 2V 20μs/div

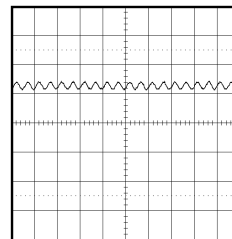

㉓ 2V 5ms/div

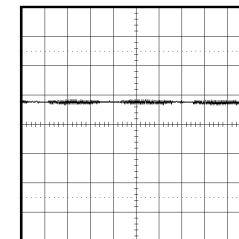

㉔ 2V 20μs/div

NOTE: The following waveforms were measured at the point of the corresponding balloon number in the schematic diagram.

## WAVEFORMS

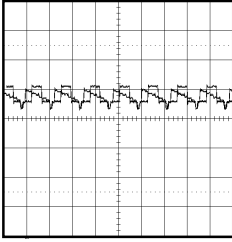

③① 1V 50 $\mu$ s/div

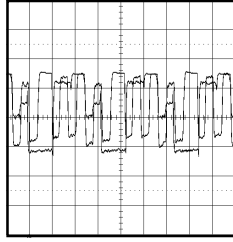

③⑨ 50V 20 $\mu$ s/div

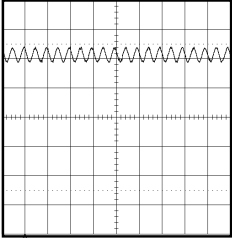

③② 2V 5ms/div

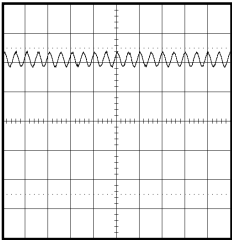

③③ 2V 5ms/div

### CRT

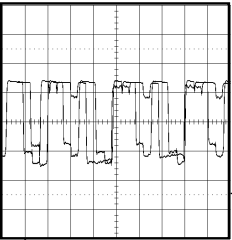

③⑦ 50V 20 $\mu$ s/div

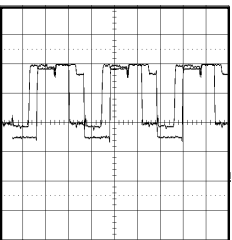

③⑧ 50V 20 $\mu$ s/div

NOTE: The following waveforms were measured at the point of the corresponding balloon number in the schematic diagram.

# MECHANICAL EXPLODED VIEW

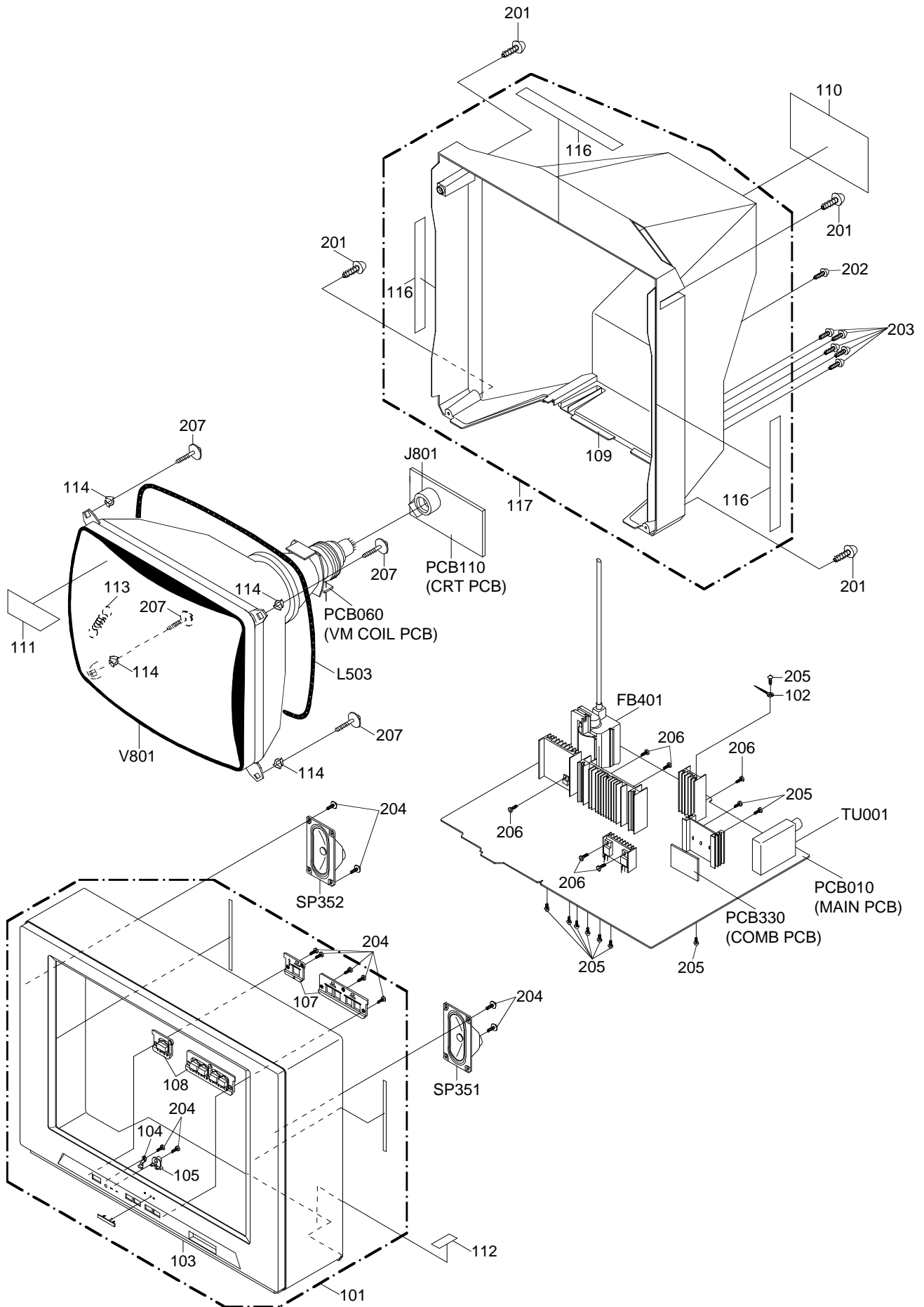

# MECHANICAL REPLACEMENT PARTS LIST

Location No.	TSB P/N	Reference No.	Description	
101	AD300823	A3J702I720	CABINET,FRONT ASSY	
102	BZ710039	8995034000	CORD CLIP UL CO.	
103	AD300626	701WPJB281	CABINET,FRONT	
104	AD300627	713WPA0116	GUIDE,REMOCON	
105	AD300628	713WPA0117	GLASS,LED	
107	AD300629	735WPAA189	BUTTON,BASE	
108	AD300630	735WPBA102	BUTTON,FRAME	
109	AD300714	702WPAA168	CABINET,BACK ASS'Y	
110	AD300632	722549A016	SHEET,RATING	
111	AD300633	723000B626	FILM,DECORATION	
112	AD300007	7230006755	SHEET,CAUTION	
113	BZ710009	741WUA0019	SPRING,EARTH	
114	AD300135	769WSA0011	WASHER CRT T=0.5	
116	AD300134	800WQ00039	FELT SHEET	
117	AD300824	A3J702I740	CABINET,BACK ASSY	
201	BZ710035	8117540A64	SCREW,TAPPING(B0) TRUSS	4x16
202	BZ710262	8117540A04	SCREW,TAPPING(B0) TRUSS	4x10
203	BZ710031	8110630A04	SCREW,TAP TITE(P) BRAZIER	3x10
204	BZ710030	8110630804	SCREW,TAP TITE(P) BRAZIER	3x8
205	BZ710019	8109630802	SCREW,TAP TITE(B) BRAZIER	3x8
206	BZ710239	8109130A04	SCREW,TAP TITE(B) WH7	3x10
207	BZ710383	8121J50C04	SCREW,TAPPING(B0) GW15	
---	AD300634	792WHA0302	PACKAGE,BOTTOM	
---	AD300635	792WHA0303	PACKAGE, TOP	
---	AD300636	793WCDA979	GIFT BOX	
---	AD300637	A3J702B975	INSTRUCTION BOOK KIT	
---	AD300436	J3I70416	IMPORTANT SAFETY INSTRUCTIONS	
---	AD300022	J3I70417	REGISTRATION CARD	
---	AD300023	J3I70436	ESP CARD	
---	AD300638	J3J70201	INSTRUCTION BOOK	
---	AD300437	JA4UD400	POLYBAG	

# ELECTRICAL REPLACEMENT PARTS LIST

Location No.	TSB P/N	Reference No.	Description
<b>RESISTORS</b>			
△R001	BZ210008	R3X181273J	R,METAL OXIDE 27K OHM 1W
△R410	AD300420	R5X2CE332J	R,CEMENT 3.3K OHM 7W
△R411	AD300032	R6558AR39J	R,FUSE 0.39 OHM 2W
R416	AD300040	R3X18A2R2J	R,METAL OXIDE 2.2 OHM 2W
△R418	BZ210089	R4X5T6273F	R,METAL 27K OHM 1/6W
△R422	BZ210013	R4X5T4104F	R,METAL 100K OHM 1/4W
△R423	AD300042	R3X18A010J	R,METAL OXIDE 1 OHM 2W
△R426	BZ210114	R4X5T6123F	R,METAL 12K OHM 1/6W
△R431	AD300600	R655812R2J	R,FUSE 2.2 OHM 1W
△R436	BZ210114	R4X5T6123F	R,METAL 12K OHM 1/6W
△R438	AD300601	R6358A6R8J	R,FUSE 6.8 OHM 2W
△R439	AD300043	R3X181102J	R,METAL OXIDE 1K OHM 1W
△R441	AD300602	R4X5T6222F	R,METAL 2.2K OHM 1/6W
△R500	BZ210080	R0G3K2275K	RC 2.7M OHM 1/2W
△R501	BZ210031	R5X2CE1R2J	R,CEMENT 1.2 OHM 7W
△R505	AD300038	R3X20B473J	R,METAL 47K OHM 3W
R516	AD300603	R3X28BR56J	R,METAL OXIDE 0.56 OHM 3W
△R517	AD300035	R5X2CE010J	R,CEMENT 1 OHM 7W
△R521	AD300041	R3X18A270J	R,METAL OXIDE 27 OHM 2W
△R522	AD300041	R3X18A270J	R,METAL OXIDE 27 OHM 2W
△R542	BZ210002	R33681R15J	R,METAL 0.15OHM 1W
△R543	BZ210049	R635U2681J	R,FUSE 680 OHM 1/2W
△R554	AD300604	R002T2223J	RC 22K OHM 1/2W
R638	AD300705	R3X181181J	R,METAL OXIDE 180 OHM 1W
R639	AD300706	R001T6123J	RC 12K OHM 1/6W
△R804	BZ210050	R3X18A123J	R,METAL OXIDE 12K OHM 2W
△R806	BZ210050	R3X18A123J	R,METAL OXIDE 12K OHM 2W
△R808	BZ210050	R3X18A123J	R,METAL OXIDE 12K OHM 2W
<b>CAPACITORS</b>			
C368	AD300067	E02LF4102M	CE 1000 UF 35V
C369	AD300067	E02LF4102M	CE 1000 UF 35V
△C408	BZ110032	E5EZF3102M	CE 1000 UF 25V
C412	BZ110057	E53FF56R8K	CE 6.8 UF 50V NP
△C413	AD300066	E02LF4222M	CE 2200 UF 35V
△C420	BZ110087	P414F9682H	CMPP 0.0068UF 1.6KV ECWH
C422	AD300605	P411F4224J	CMPP 0.22 UF 400V ECWF
△C423	AD300606	P414F9562H	CMPP 0.0056UF 1.6KV ECWH
△C424	BZ110054	P3N1F5333J	CPP 0.033 UF 630V
C425	AD300077	C0JLYR713K	CC 0.001 UF 2KV YR
△C426	AD300061	E5EZF2220M	CE 22 UF 250V
△C428	BZ110041	E02LT3471M	CE 470 UF 25V
△C430	AD300064	E02LT8220M	CE 22 UF 100V
△C501	AD300066	E02LF4222M	CE 2200 UF 35V
△C502	BZ110061	C0JTB0513K	CC 0.001 UF 500V B
△C502	BZ110061	C0JTB0513K	CC 0.001 UF 500V B
△C503	BZ110061	C0JTB0513K	CC 0.001 UF 500V B
△C503	BZ110061	C0JTB0513K	CC 0.001 UF 500V B
△C505	BZ110035	P2122B104M	CMP 0.1 UF 250V ECQUL
△C506	BZ110035	P2122B104M	CMP 0.1 UF 250V ECQUL
△C507	AD300607	E51CGC331M	CE 330 UF 200V
△C510	BZ110018	E5EZT4101M	CE 100 UF 35V
△C513	BZ110066	C034E0J13M	CC 0.001 UF 125V MX
△C514	BZ110066	C034E0J13M	CC 0.001 UF 125V MX
C517	BZ110115	C0JLYR7H3K	CC 0.0022UF 2KV YR
△C519	BZ110066	C034E0J13M	CC 0.001 UF 125V MX
△C522	BZ110066	C034E0J13M	CC 0.001 UF 125V MX
C523	AD300060	E62NFB101M	CE 100 UF 160V
△C527	AD300125	E5EZF2222M	CE 2200 UF 16V
△C531	BZ110081	E02LT2471M	CE 470 UF 16V
C535	BZ110115	C0JLYR7H3K	CC 0.0022UF 2KV YR
C536	AD300077	C0JLYR713K	CC 0.001 UF 2KV YR
C611	AD300439	P6M9T0474J	CMPL 0.47 UF 50V TF
C643	AD300707	E50HT2470M	CE 47 UF 16 V
C808	AD300078	C0JBB0713K	CC 0.001 UF 2KV B
<b>DIODES</b>			
D001	AD300072	D94TA30013	DIODE,ZENER HZ30-3L TD
D102	BZ410006	D1VT001330	DIODE,SILICON 1SS133T-77
D103	BZ410006	D1VT001330	DIODE,SILICON 1SS133T-77
D104	BZ410006	D1VT001330	DIODE,SILICON 1SS133T-77
D107	BZ410006	D1VT001330	DIODE,SILICON 1SS133T-77
D108	BZ410021	D97U05R61B	DIODE,ZENER MTZJ5.6B T-77
D109	BZ410054	0021721150	LED SLR-342VCT32
D201	AD300070	D97U01201B	DIODE,ZENER MTZJ12B T-77
△D401	AD300069	D97U02701B	DIODE,ZENER MTZJ27B T-77
D402	BZ410043	D2WT011E10	DIODE,SILICON 11E1-EIC
D404	BZ410023	D97U09R11B	DIODE,ZENER MTZJ9.1B T-77
△D405	BZ410063	D2WTAU02A0	DIODE,SILICON AU02A-EIC

# ELECTRICAL REPLACEMENT PARTS LIST

Location No.	TSB P/N	Reference No.	Description
<b>DIODES</b>			
△D406	AD300071	D97U01101B	DIODE,ZENER MTZJ11B T-77
△D407	BZ410063	D2WTAU02A0	DIODE,SILICON AU02A-EIC
△D408	AD300074	D2BFRS4FS0	DIODE,SILICON RS-4FS
△D409	AD300073	D2BFRU4AM0	DIODE,SILICON RU-4AM
△D411	BZ410063	D2WTAU02A0	DIODE,SILICON AU02A-EIC
△D412	BZ410063	D2WTAU02A0	DIODE,SILICON AU02A-EIC
△D501	BZ410062	D2WTRM11C0	DIODE,SILICON RM11C-EIC
△D502	BZ410062	D2WTRM11C0	DIODE,SILICON RM11C-EIC
△D503	BZ410062	D2WTRM11C0	DIODE,SILICON RM11C-EIC
△D504	BZ410062	D2WTRM11C0	DIODE,SILICON RM11C-EIC
△D505	AD300076	D28F30DF60	DIODE RECTIFIER 30DF6-FC
△D506	BZ410011	D28TELS2N2	DIODE RECTIFIER 10ELS2N-TA1B2
D507	BZ410006	D1VT001330	DIODE,SILICON 1SS133T-77
D508	BZ410006	D1VT001330	DIODE,SILICON 1SS133T-77
△D510	AD300076	D28F30DF60	DIODE RECTIFIER 30DF6-FC
D511	AD300075	D28TELS6N6	DIODE RECTIFIER 10ELS6N-TA1B2
△D512	BZ410076	D2WXB290S0	DIODE,SILICON SB290S
D513	BZ410021	D97U05R61B	DIODE,ZENER MTZJ5.6B T-77
△D514	BZ410076	D2WXB290S0	DIODE,SILICON SB290S
D515	BZ410047	D2BTRU2YX0	DIODE,SILICON RU2YX-V1
D516	BZ410006	D1VT001330	DIODE,SILICON 1SS133T-77
D517	BZ410006	D1VT001330	DIODE,SILICON 1SS133T-77
D518	BZ410006	D1VT001330	DIODE,SILICON 1SS133T-77
D519	BZ410006	D1VT001330	DIODE,SILICON 1SS133T-77
D520	BZ410006	D1VT001330	DIODE,SILICON 1SS133T-77
△D521	BZ410006	D1VT001330	DIODE,SILICON 1SS133T-77
D525	BZ410020	D97U05R11B	DIODE,ZENER MTZJ5.1B T-77
D528	BZ410021	D97U05R61B	DIODE,ZENER MTZJ5.6B T-77
D602	BZ410066	D97U06R21B	DIODE,ZENER MTZJ6.2B T-77
D603	BZ410066	D97U06R21B	DIODE,ZENER MTZJ6.2B T-77
D604	BZ410066	D97U06R21B	DIODE,ZENER MTZJ6.2B T-77
D605	BZ410043	D2WT011E10	DIODE,SILICON 11E1-EIC
D611	BZ410006	D1VT001330	DIODE,SILICON 1SS133T-77
D613	BZ410006	D1VT001330	DIODE,SILICON 1SS133T-77
D614	BZ410006	D1VT001330	DIODE,SILICON 1SS133T-77
D711	BZ410066	D97U06R21B	DIODE,ZENER MTZJ6.2B T-77
D801	BZ410006	D1VT001330	DIODE,SILICON 1SS133T-77
D802	BZ410006	D1VT001330	DIODE,SILICON 1SS133T-77
D803	BZ410006	D1VT001330	DIODE,SILICON 1SS133T-77
<b>ICS</b>			
IC101	AD300051	I56D07054A	IC OEC7054A
IC103	AD300050	I9UJ0T600C	IC PST600C
IC199	AD300608	A3J702B015	IC S-24C08ADPA-01
IC201	AD300058	I05DC12530	IC TB1253N
IC303	BZ611034	I06DF62420	IC M62420SP
△IC353	AD300056	I0FSP52760	IC AN5276
△IC401	BZ611053	I01TD55220	IC AN5522
△IC501	BZ611041	I2BT066230	IC STR-G6623
△IC502	BZ611033	I1KA97809A	IC KIA7809API
△IC503	BZ611015	I1KA97805A	IC KIA7805API
IC701	AD300054	I0UD013110	IC MM1311AD
IC902	AD300059	I01FF58290	IC AN5829S
IC1501	AD300609	I05FE90A45	IC TC90A45F
<b>TRANSISTORS</b>			
Q101	BZ510002	T8YJ2412K0	TRANSISTOR,SILICON 2SC2412KT146 R,S
Q102	BZ510002	T8YJ2412K0	TRANSISTOR,SILICON 2SC2412KT146 R,S
Q103	BZ510071	TNAAB05003	COMPOUND TRANSISTOR KRC102RTK
Q104	BZ510024	TNYTJ03001	COMPOUND TRANSISTOR DTC114TSTP
Q105	BZ510025	TPYJB05001	COMPOUND TRANSISTOR DTA114EKAT146
Q109	BZ510002	T8YJ2412K0	TRANSISTOR,SILICON 2SC2412KT146 R,S
Q201	BZ510002	T8YJ2412K0	TRANSISTOR,SILICON 2SC2412KT146 R,S
Q202	BZ510002	T8YJ2412K0	TRANSISTOR,SILICON 2SC2412KT146 R,S
Q203	BZ510001	T6YJ1037K0	TRANSISTOR,SILICON 2SA1037AKT146R,S
Q204	AD300030	T83A028140	TRANSISTOR,SILICON 2SC2814(F3,F4)-T
Q351	BZ510022	TNYJJ05001	COMPOUND TRANSISTOR DTC114TKAT146
Q401	BZ510034	TA5T010154	TRANSISTOR,SILICON 2SA1015Y(TPE2)
△Q402	BZ510027	TC3Q026210	TRANSISTOR,SILICON 2SC2621(D,E)-RAC
Q403	BZ510034	TA5T010154	TRANSISTOR,SILICON 2SA1015Y(TPE2)
Q404	AD300027	TC30041590	TRANSISTOR,SILICON 2SC4159(D,E)
△Q405	BZ510040	TDUU024990	TRANSISTOR,SILICON 2SD2499(LBOEC1)
Q406	AD300610	TPAAD05003	COMPOUND TRANSISTOR KRA104RTK
△Q501	BZ510031	TD3T007340	TRANSISTOR,SILICON 2SD734(E,F)-AA
△Q502	BZ410088	0002E00610	PHOTO COUPLER LTV-817M-VB
Q504	BZ510012	TC5T018154	TRANSISTOR,SILICON 2SC1815Y(TPE2)
Q505	BZ510030	TA3T01624E	TRANSISTOR,SILICON 2SA1624E-AA
Q506	BZ510024	TNYTJ03001	COMPOUND TRANSISTOR DTC114TSTP
△Q507	BZ510012	TC5T018154	TRANSISTOR,SILICON 2SC1815Y(TPE2)

# ELECTRICAL REPLACEMENT PARTS LIST

Location No.	TSB P/N	Reference No.	Description
<b>TRANSISTORS</b>			
△ Q508	AD300611	TAAT01273Y	TRANSISTOR,SILICON KTA1273_Y
Q509	BZ510071	TNAAB05003	COMPOUND TRANSISTOR KRC102RTK
△ Q510	BZ510031	TD3T007340	TRANSISTOR,SILICON 2SD734(E,F)-AA
Q604	BZ510024	TNYTJ03001	COMPOUND TRANSISTOR DTC114TSTP
Q701	BZ510002	T8YJ2412K0	TRANSISTOR,SILICON 2SC2412KT146 R,S
Q704	BZ510002	T8YJ2412K0	TRANSISTOR,SILICON 2SC2412KT146 R,S
Q705	BZ510002	T8YJ2412K0	TRANSISTOR,SILICON 2SC2412KT146 R,S
Q709	BZ510001	T6YJ1037K0	TRANSISTOR,SILICON 2SA1037AKT146R,S
△ Q801	BZ510027	TC3Q026210	TRANSISTOR,SILICON 2SC2621(D,E)-RAC
△ Q802	BZ510027	TC3Q026210	TRANSISTOR,SILICON 2SC2621(D,E)-RAC
△ Q803	BZ510027	TC3Q026210	TRANSISTOR,SILICON 2SC2621(D,E)-RAC
△ Q810	AD300442	TCYT1740S0	TRANSISTOR,SILICON 2SC1740SP TP
△ Q811	AD300442	TCYT1740S0	TRANSISTOR,SILICON 2SC1740SP TP
△ Q812	AD300442	TCYT1740S0	TRANSISTOR,SILICON 2SC1740SP TP
Q1501	BZ510002	T8YJ2412K0	TRANSISTOR,SILICON 2SC2412KT146 R,S
Q1502	BZ510001	T6YJ1037K0	TRANSISTOR,SILICON 2SA1037AKT146R,S
Q1503	BZ510002	T8YJ2412K0	TRANSISTOR,SILICON 2SC2412KT146 R,S
Q1504	BZ510002	T8YJ2412K0	TRANSISTOR,SILICON 2SC2412KT146 R,S
<b>COILS &amp; TRANSFORMERS</b>			
L001	BZ310078	021LA6R68M	COIL 0.68 UH
L101	AD300121	021LA62R7K	COIL 2.7 UH
L201	BZ310041	02167F101J	COIL 100 UH
L202	AD300127	02161CR82M	COIL 0.82 UH
L203	BZ310009	021LA62R2K	COIL 2.2 UH
L204	BZ310038	021LA6120K	COIL 12 UH
L205	BZ310003	021673470K	COIL 47 UH
L301	BZ310029	021LA6470K	COIL 47 UH
L302	BZ310058	021LA6220K	COIL 22 UH
L401	AD300117	02D1000001	COIL ELC16B501EN
L402	BZ310013	0221000013	COIL,LINEARITY ELH5L4112N
△ L501	AD300119	029T000097	COIL,LINE FILTER 1R5A123F28Y
△ L503	BZ310116	028R140023	COIL,DEGAUSS 8R140023
L505	BZ310002	021673101K	COIL 100 UH
L601	BZ310003	021673470K	COIL 47 UH
L602	BZ310002	021673101K	COIL 100 UH
L603	BZ310003	021673470K	COIL 47 UH
L604	BZ310003	021673470K	COIL 47 UH
L701	BZ310001	021673101J	COIL 100 UH
L703	BZ310003	021673470K	COIL 47 UH
L802	AD300123	021673151K	COIL 150 UH
L803	AD300123	021673151K	COIL 150 UH
L804	AD300123	021673151K	COIL 150 UH
L810	AD300118	02AXB9A971	CORE FERRITE ESD-R-30SD
L901	BZ310058	021LA6220K	COIL 22 UH
L1501	AD300612	02167F100J	COIL 10 UH
L1502	AD300613	02167F150J	COIL 15 UH
L1503	AD300614	021673821K	COIL 820 UH
L1504	BZ310041	02167F101J	COIL 100 UH
L1505	AD300615	02167F151J	COIL 150 UH
L1506	BZ310039	02167F220J	COIL 22 UH
T401	BZ310072	045013001J	TRANS.HORIZONTAL DRIVE 5013001
△ T501	AD300115	0481400614	TRANSFORMER,SWITCHING 81400614
<b>JACKS</b>			
△ J351	BZ614144	0602131011	HEADPHONE JACK HSJ2000-01-010
J701	AD300113	0602431011	JACK RCA JPJ4312-01-432
J702	AD300108	063Q700002	JACK YKF51-5503
J703	AD300113	0602431011	JACK RCA JPJ4312-01-432
J704	AD300109	060X411015	RCA JACK JPJ4311-011852
J705	AD300113	0602431011	JACK RCA JPJ4312-01-432
J710	AD300110	060G401047	RCA JACK HTJ-032-03AY
J711	AD300111	060G401046	RCA JACK HTJ-032-03AW
J712	AD300112	060G401039	RCA JACK HTJ-032-03AR
△ J801	BZ614004	066X120014	SOCKET,CATHODE RAY TUBE HPS3200-010501
<b>SWITCHES</b>			
SW101	BZ612001	0504201T31	SWITCH,TACT SKHVBED010
SW102	BZ612001	0504201T31	SWITCH,TACT SKHVBED010
SW103	BZ612001	0504201T31	SWITCH,TACT SKHVBED010
SW104	BZ612001	0504201T31	SWITCH,TACT SKHVBED010
SW105	BZ612001	0504201T31	SWITCH,TACT SKHVBED010
<b>VARIABLE RESISTORS</b>			
VR502	BZ210068	V1163Q3BTC	VOLUME,SEMI FIXED EVNCRYAA03BQ3
<b>P.C. BOARD ASSEMBLIES</b>			
PCB010	AD300819	A3J702I01A	PCB ASSY TMA510A
PCB060	AD300820	A3J702I06A	PCB ASSY TEXA52A
PCB110	AD300821	A3J702I11A	PCB ASSY TCA365A
PCB330	AD300822	A3J702I33A	PCB ASSY TEAA76A

# ELECTRICAL REPLACEMENT PARTS LIST

Location No.	TSB P/N	Reference No.	Description
<b>MISCELLANEOUS</b>			
B501	BZ310045	024AT03481	CORE,BEADS
B502	BZ310015	024AT03482	CORE,BEADS
B504	BZ310016	024AT03655	CORE,BEADS
B505	BZ310015	024AT03482	CORE,BEADS
CD351	AD300620	06CH14396A	CORD CONNECTOR
△CD501	BZ614053	120R614909	CORD AC
CD701A	AD300622	06CH243001	CORD CONNECTOR
CD801	AD300085	122E063701	CORD JUMPER
CD802	AD300084	122E075701	CORD JUMPER
△CD803	BZ614122	06CP82035A	CORD CONNECTOR
CF201	BZ613015	1011T4R504	FILTER,CERAMIC
CF202	AD300621	1022T45R73	FILTER,SAW
CF202	AD300621	1022T45R73	FILTER,SAW
CF203	BZ613016	1011T4R517	FILTER,CERAMIC
CF204	AD300513	1012T04702	FILTER,CERAMIC TRAP
CP101	BZ614135	0694260139	CONNECTOR PCB SIDE
CP351	AD300097	069W14T299	CONNECTOR PCB SIDE
△CP401	AD300095	069X460029	CONNECTOR PCB SIDE
△CP501	BZ614012	0697320039	CORD UX CONNECTOR
△CP502	BZ614018	069W420029	CONNECTOR PCB SIDE
CP503	BZ614058	069W010010	CONNECTOR PCB SIDE
CP504	BZ614058	069W010010	CONNECTOR PCB SIDE
CP801	AD300099	069R260589	CONNECTOR PCB SIDE
CP802	AD300098	069R270589	CONNECTOR PCB SIDE
CP803	BZ614017	069W320018	CONNECTOR PCB SIDE
CP804	BZ614058	069W010010	CONNECTOR PCB SIDE
CP901	AD300102	069J160260	CONNECTOR PCB SIDE
CP1501	AD300102	069J160260	CONNECTOR PCB SIDE
CP801A	AD300105	067R006019	WIRE HOLDER
CP802A	AD300104	067R007019	WIRE HOLDER
EL001	BZ614044	124120301A	EYE LET
EL002	BZ614043	124116281A	EYE LET
△F501	BZ614125	081PC6R304	FUSE
△FB401	BZ310123	043214032R	TRANSFORMER,FLYBACK
FH501	BZ614005	06710T0006	HOLDER,FUSE
FH502	BZ614005	06710T0006	HOLDER,FUSE
OS101	BZ614171	077Q014003	REMOTE RECEIVER
△RY501	AD300114	0560V20115	RELAY
△SP351	BZ614029	070C533008	SPEAKER
△SP352	BZ614029	070C533008	SPEAKER
△TH501	AD300068	DF40B3R0Q0	DEGAUSS ELEMENT
TM101	AD300091	07660DU010	TRANSMITTER
△TU001	BZ610125	0145K00055	TUNER,VHF-UHF
△V801	AD300623	09811404B8	CRT W/DY
X101	AD300624	1001T8R004	CERAMIC,OSCILLATOR
X601	BZ613004	100CT3R505	CRYSTAL
			BL02RN1-R62T2
			BL02RN2-R62T4
			BL01RN1-A63T6
			BL02RN2-R62T4
			CH14396A
			0R614909
			CH243001
			2E063701
			2E075701
			CP82035A
			EFCT4R5YS5A
			SAFGP45M7VHCZR
			SAFGP45M7VHCZR
			EFCT4R5MW5
			MKT47.3MC110P-TF
			173979-6
			TID-X04P-Z1
			B06B-DVS
			THL-P03P-B1
			TV-50P-02-A1
			005P-2100
			005P-2100
			52147-0610
			52147-0710
			TS-80P-02-V1
			005P-2100
			6035B-06Z002-T
			6035B-06Z002-T
			51048-0610
			51048-0710
			XRY20X30BD
			XRY16X28BD
			51MS063LCC
			3214032R
			EYF-52BC
			EYF-52BC
			PIC-28143SY-2
			ALKS321
			810-47-171
			810-47-171
			PTBD14K2-3R0Q141
			SBKMOP006A
			TECC1040PG32D
			A36LTN194X81
			EFOEC8004T4
			HC-49/C
<b>RESISTOR</b>			
	RC.....	CARBON RESISTOR	
<b>CAPACITORS</b>			
	CC.....	CERAMIC CAPACITOR	
	CE.....	ALUMI ELECTROLYTIC CAPACITOR	
	CP.....	POLYESTER CAPACITOR	
	CPP.....	POLYPROPYLENE CAPACITOR	
	CPL.....	PLASTIC CAPACITOR	
	CMP.....	METAL POLYESTER CAPACITOR	
	CMPL.....	METAL PLASTIC CAPACITOR	
	CMPP.....	METAL POLYPROPYLENE CAPACITOR	

TOSHIBA AMERICA CONSUMER PRODUCTS ,INC.

1-1, SHIBAURA 1-CHOME, MINATO-KU, TOKYO 105-8001, JAPAN