

Service Manual

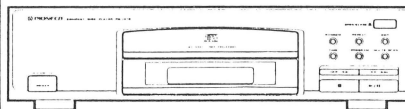

ORDER NO.
ARP2645

COMPACT DISC PLAYER

PD-J410

PD-J410 HAS THE FOLLOWING:

Type	Power Requirement	Remarks
AEMXK	AC power supplied from power transformer's secondary of other system component	
ABXK		
ADL		

- This manual is applicable to PD-J410/AEMXK, ABXK and ADL.
- For ABXK and ADL types, refer to page 33.
- These products are systems components.

Each of these products does not function properly when independent; to avoid malfunctions, be sure to connect it to the prescribed system component(s), otherwise damage may result.

These products' accessories etc. are packed with their related component(s).

CONTENTS

1. SAFETY INFORMATION	2
2. EXPLODED VIEWS, PACKING AND PARTS LIST	3
3. SCHEMATIC DIAGRAM	9
4. PCB CONNECTION DIAGRAM	15
5. PCB PARTS LIST	21
6. ADJUSTMENTS	23
7. FOR ABXK AND ADL TYPES	33
8. PANEL FACILITIES	34
9. SPECIFICATIONS	35

1. SAFETY INFORMATION

(FOR EUROPEAN MODEL ONLY)

VARO!
AVATTAESSA JA SUOJALUKITUS OHITETTAESSA OLET ALTTIINA NÄKYMÄTTÖMÄLLE LASERSÄTEILYLLE. ÄLÄ KATSO SÄTEESEEN.



LASER
Kuva 1
Lasersäteilyn varoitusmerkki

WARNING!
DEVICE INCLUDES LASER DIODE WHICH EMITS INVISIBLE INFRARED RADIATION WHICH IS DANGEROUS TO EYES. THERE IS A WARNING SIGN ACCORDING TO PICTURE 1 INSIDE THE DEVICE CLOSE TO THE LASER DIODE.



LASER
Picture 1
Warning sign for laser radiation

ADVERSEL:
USYNLIG LASERSTRÅLING VED ÅBNING NÅR SIKKERHEDSAFBRYDERE ER UDE AF FUNKTION UNDGÅ UDSAETTELSE FOR STRÅLING.

IMPORTANT
THIS PIONEER APPARATUS CONTAINS LASER OF CLASS 1. SERVICING OPERATION OF THE APPARATUS SHOULD BE DONE BY A SPECIALLY INSTRUCTED PERSON.

VARNING!
OSYNLIG LASERSTRÅLNING NÅR DENNA DEL ÄR ÖPPNAD OCH SPÄRREN ÄR URKOPPLAD. BETRAKTA EJ STRÅLEN.

LASER DIODE CHARACTERISTICS
MAXIMUM OUTPUT POWER: 5 mw
WAVELENGTH: 780-785 nm

LABEL CHECK

AEMXK, ABXK and ADL types



ABXK and ADL types

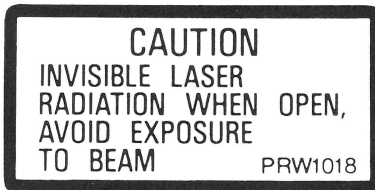

AEMXK type

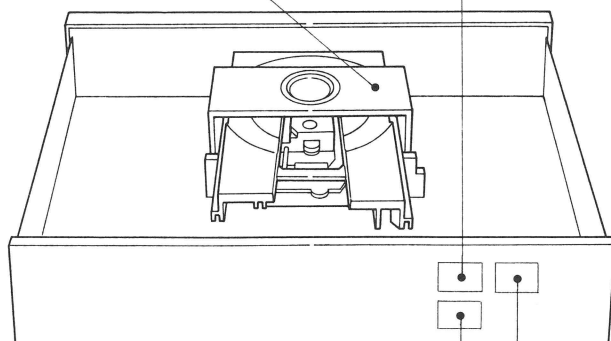

Additional Laser Caution

- Laser Interlock Mechanism**
The position of the switch (S601) for detecting loading completion is detected by the system microprocessor, and the design prevents laser diode oscillation when the switch (S601) is not in CLMP terminal side (when CLMP signal is OFF, that is high level). Thus, the interlock will no longer function if the switch (S601) is deliberately set to CLMP terminal side (if CLMP signal is low level).
The interlock also does not operate in the test mode*. Laser diode oscillation will continue, if pin 1 of M51593FP (IC101) on the preamplifier board loaded on pickup assembly are connected to GND, or pin 19 is connected to low level (ON), or else the terminals of Q101 are shorted to each other (fault condition).
- When the cover is opened, close viewing of the objective lens with the naked eye will cause exposure to a Class 1 laser beam.

* Refer to page 24.

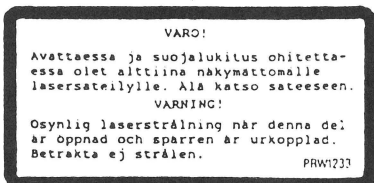

AEMXK type

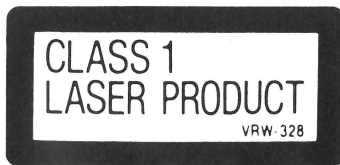

AEMXK, ABXK and ADL types

2. EXPLODED VIEWS, PACKING AND PARTS LIST

2.1 EXTERIOR

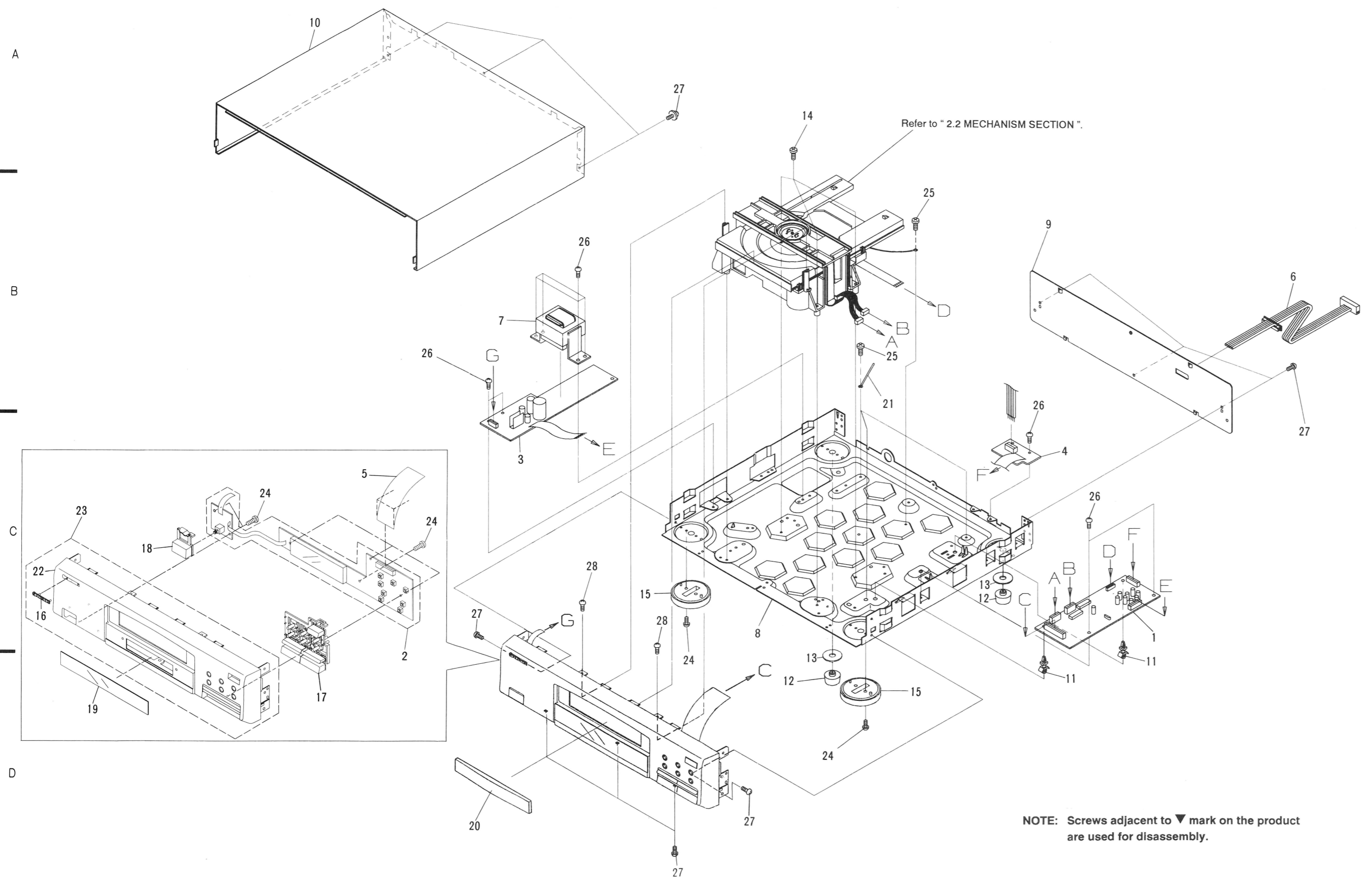

NOTES:

- Parts marked by "NSP" are generally unavailable because they are not in our Master Spare Parts List.
- The Δ mark found on some component parts indicates the importance of the safety factor of the part. Therefore, when replacing, be sure to use parts of identical designation.
- Parts marked by "⊙" are not always kept in stock. Their delivery time may be longer than usual or they may be unavailable.

Parts List

Mark	No.	Description	Part No.
	1	Mother board assembly	PWM1709
	2	Function board assembly	PWZ2430
	3	Power board assembly	PWZ2431
	4	Connector board assembly	PWZ2432
	5	24P F.F.C./30V	PDD1113
	6	Cord with connector	PDE1107
Δ	7	Power transformer	PTT1276
NSP	8	Under base	PNA1901
NSP	9	Rear base	PNA1909
	10	Bonnet	REA1004
NSP	11	PCB holder	PNW2100
	12	Foot	PXA1201
	13	Plate	PNM1158
	14	Screw	BBZ30P160FMC
	15	Foot assembly	RXA1448
	16	Name plate	AAM1047
	17	Function button	PAC1705
	18	Power knob	PAC1733
	19	Display window	PAM1594
	20	Tray name plate	PNW2234
NSP	21	Cord clammer	RNH - 184
NSP	22	Function panel	PNW2235
NSP	23	Function panel assembly	PEA1271
	24	Screw	PPZ30P080FMC
	25	Screw	PDZ30P050FMC
	26	Screw	BBZ30P060FCC
	27	Screw	BBZ30P080FCC
	28	Screw	PPZ30P120FMC
	29	Protector (F)	PHA1224
	30	Protector (R)	PHA1225
	31	Packing case	PHG1861
	32	Mirror mat sheet	Z23 - 007
	33	Operating instructions (English/French/Italian/ Dutch/Swedish/Spanish/ Portuguese)	PRE1174

PACKING

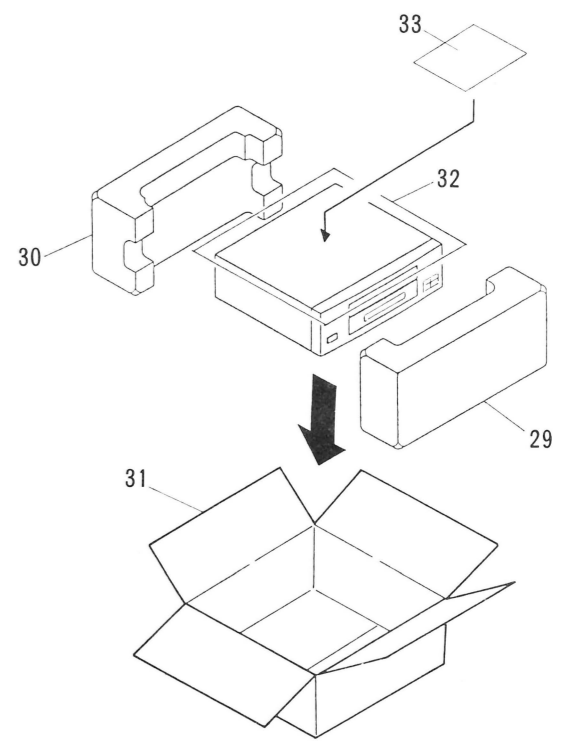

NOTE: Screws adjacent to ▼ mark on the product are used for disassembly.

2.2 MECHANISM SECTION

Parts List

Mark	No.	Description	Part No.
	1	Lever switch (CLAMP)	DSK1003
	2	Float screw	PBA1048
	3	Rubber belt	PEB1193
	4	Motor pulley	PNW1634
	5	Tray	PNW2290
	6	Float base	PNW2032
	7	Drive gear	PNW2266
	8	Gear pulley	PNW2034
	9	Clamper base	PNW2035
	10	Clamp cam	PNW2036
	11	DC motor/0.75W (LOADING)	PXM1010
	12	Float rubber	PEB1014
	13	Float rubber	PEB1132
	14	Screw	BPZ26P080FMC
	15	Screw	Z39 - 018
	16	Screw	PMZ26P040FMC
	17	Pinion gear	PNW2055
	18	DC motor (CARRIAGE)	PXM1027
	19	DC motor assembly (SPINDLE)	PEA1235
NSP	20	Carridge base	PNW2058
	21	Disc table	PNW1068
	22	Screw	JFZ20P030FNI
	23	Screw	JFZ17P025FZK
	24	Gear 3	PNW2054
	25	Gear 2	PNW2053
	26	Washer	WT12D032D025
	27	Pickup assembly	PEA1179
	28	Guide bar	PLA1094
	29	Gear 1	PNW2052
NSP	30	Gear stopper	PNB1303
	31	Screw	BPZ20P060FMC
	32	PWB holder	PNW2057
	33	Screw	BPZ26P100FMC
NSP	34	Earth lead unit	PDF1104
	35	Screw	BBZ26P060FMC
NSP	36	Mechanism board assembly	PWX1192
NSP	37	Clamp magnet	PMF1014
NSP	38	Yoke	PNB1216
NSP	39	H rubber	PEB1249
NSP	40	Clamper S	PNW1609
NSP	41	Loading base	PNW2030
	42	DC motor assembly (CARRIAGE)	PEA1246
NSP	43	Servo mechanism assembly	PXA1478
	44	Screw	BBZ30P080FZK
NSP	45	Connector assembly (4P)	PDE1145
NSP	46	Connector assembly (5P)	PDE1201

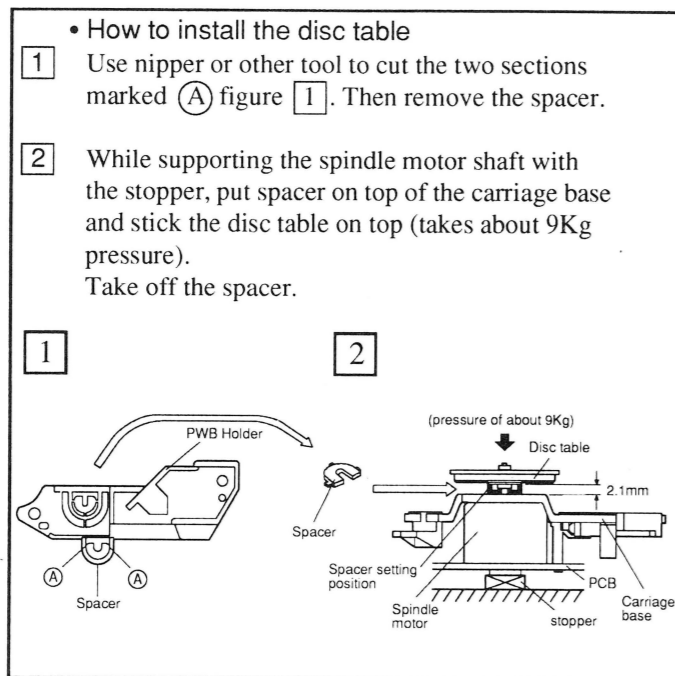

A
B
C
D

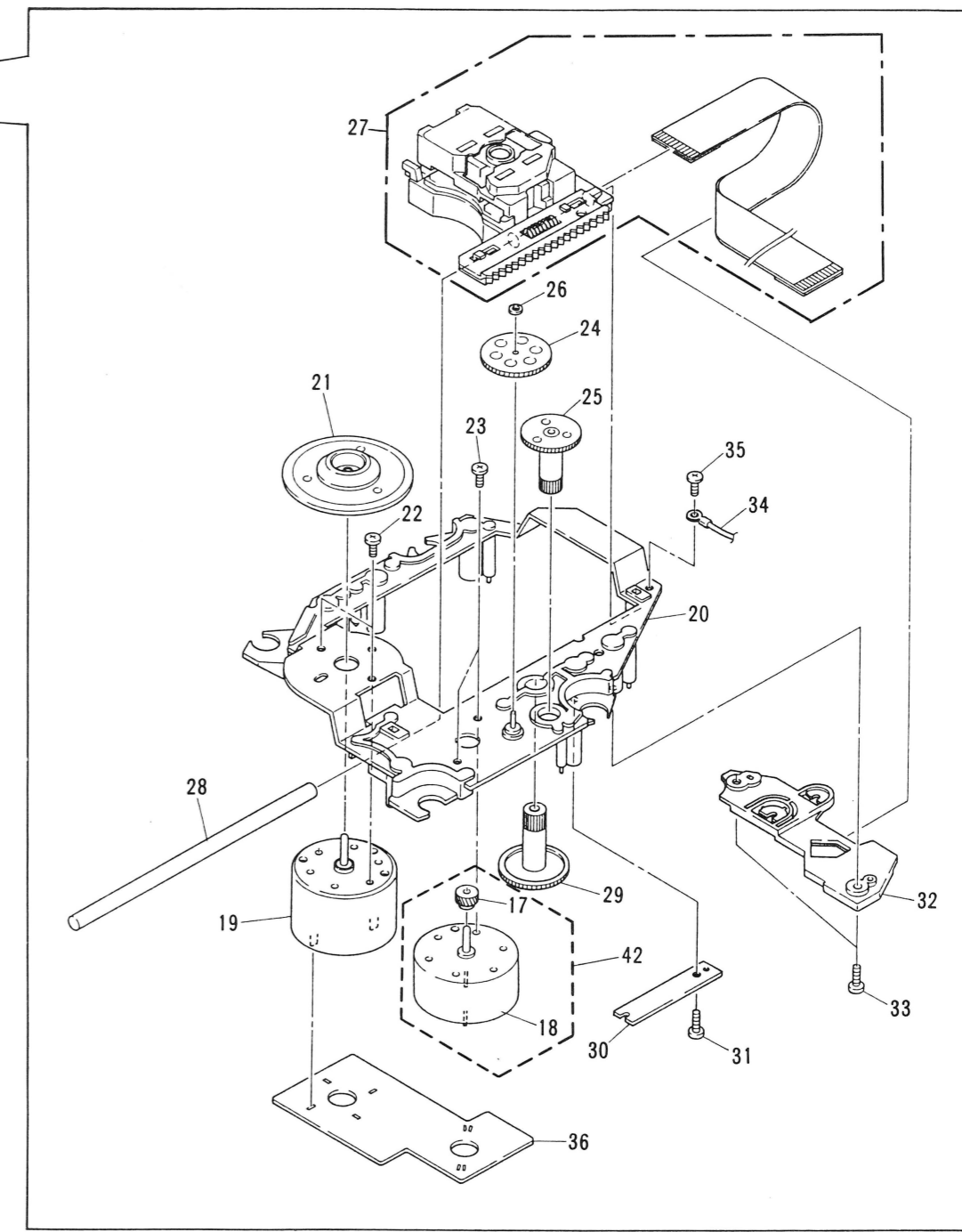
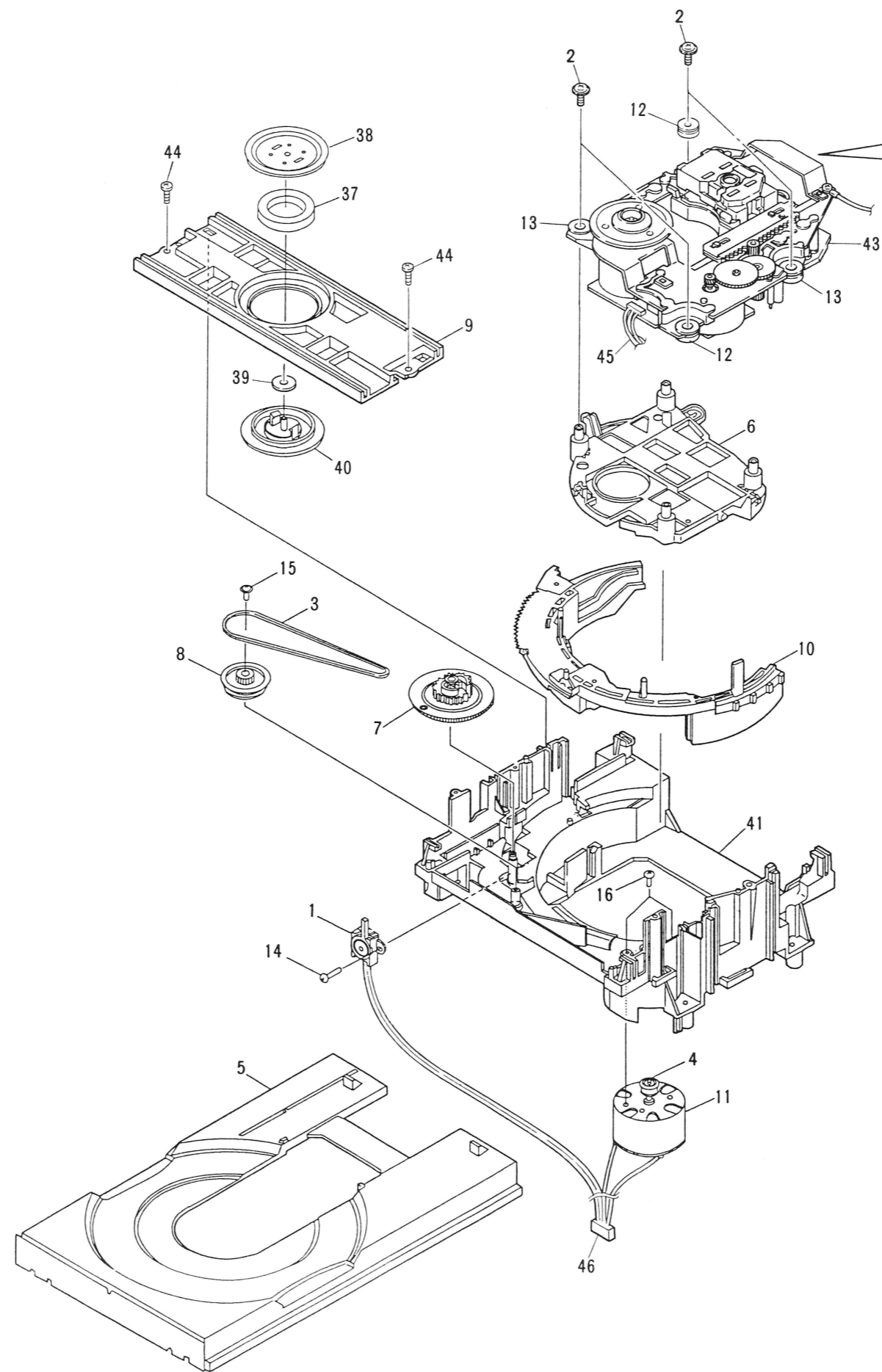

A
B
C
D

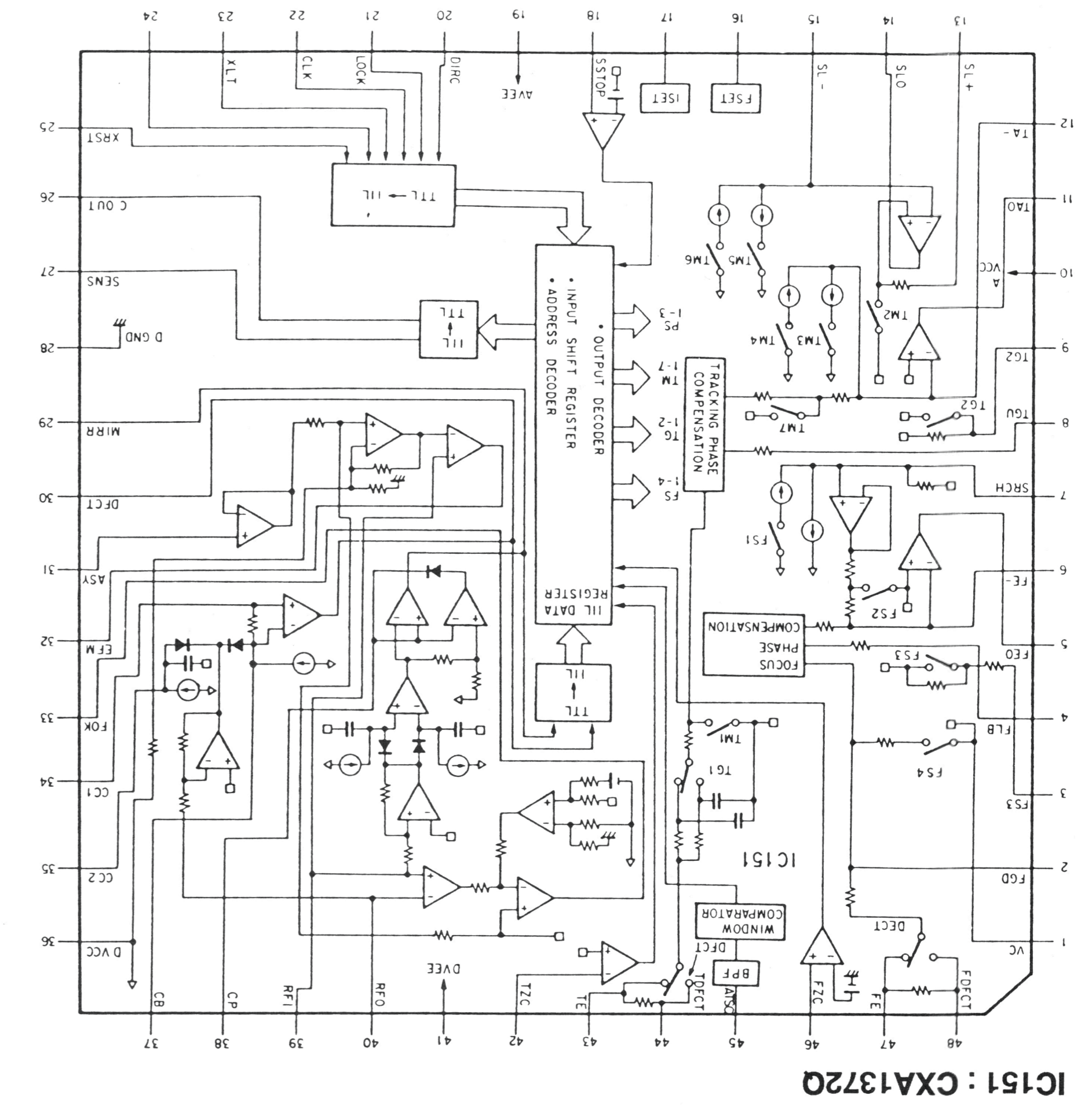
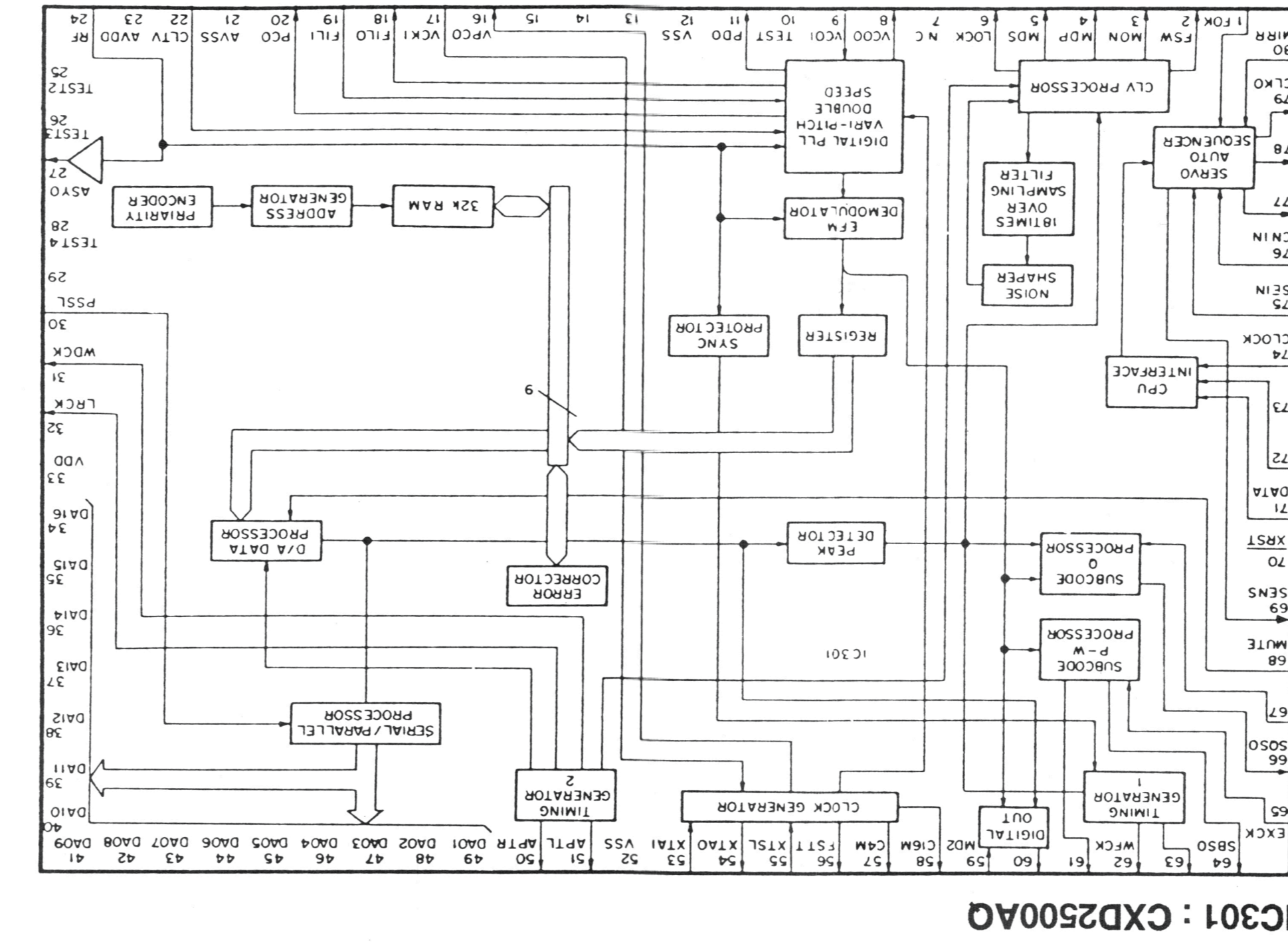
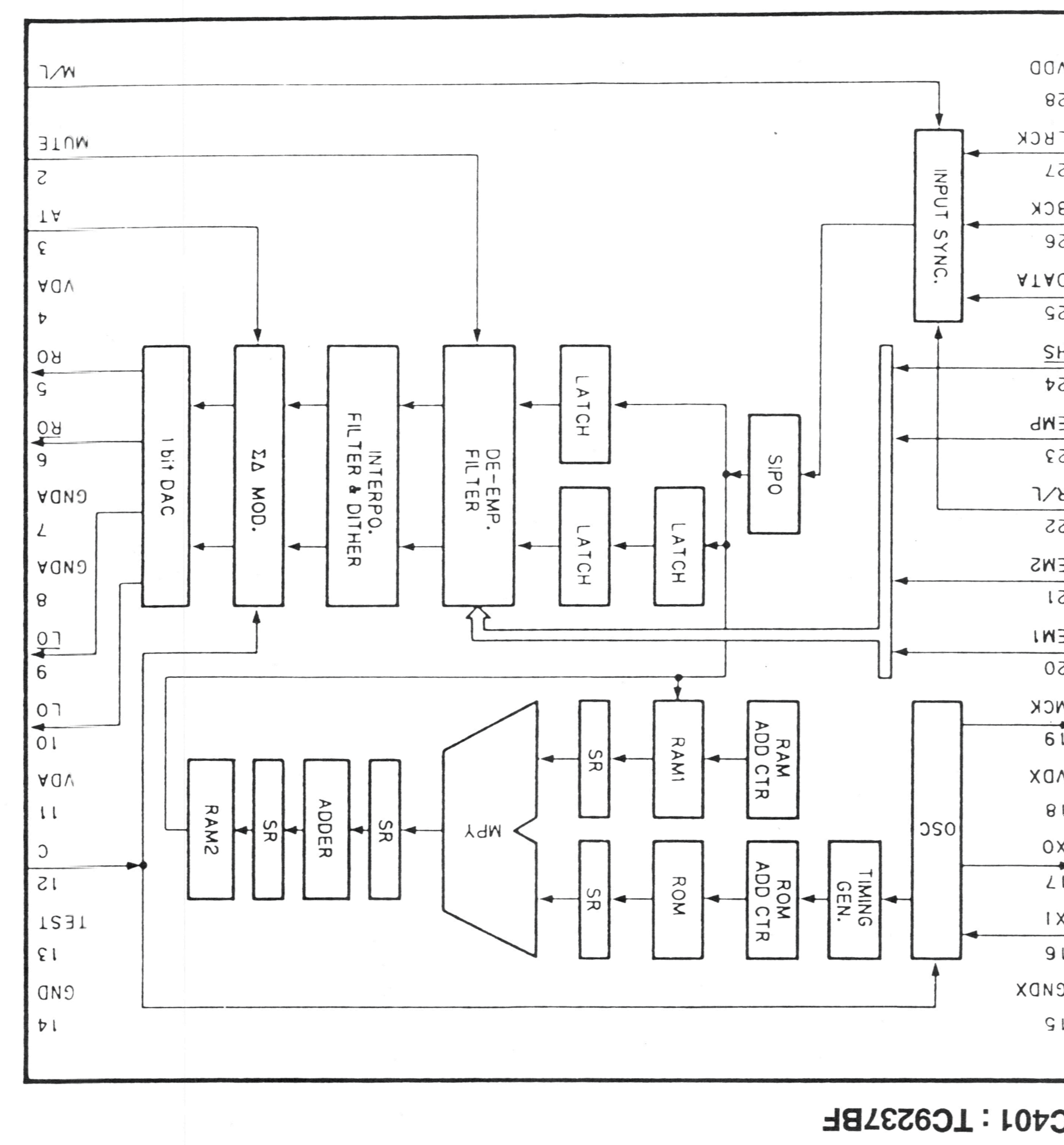

3. SCHEMATIC DIAGRAM

- Note:** (Type 4)
- When ordering service parts, be sure to refer to "PARTS LIST of EXPLODED VIEWS" or "PCB PARTS LIST".
 - Since these are basic circuits, some parts of them or the values of some components may be changed for improvement.
 - RESISTORS:**
Unit: k:kΩ, M:MΩ, or Ω unless otherwise noted.
Rated power: 1/4W, 1/6W, 1/8W, 1/10W unless otherwise noted.
Tolerance: (F): ±1%, (G): ±2%, (K): ±10%, (M): ±20% or ±5% unless otherwise noted.
 - CAPACITORS:**
Unit: p:pF or μF unless otherwise noted.
Ratings: capacitor (μF)/ voltage (V) unless otherwise noted.
Rated voltage: 50V except for electrolytic capacitors.
 - COILS:**
Unit: m:mH or μH unless otherwise noted.
 - VOLTAGE AND CURRENT:**
□ : DC voltage (V) in PLAY mode unless otherwise noted.
⊖ : mA or -mA: DC current in PLAY mode unless otherwise noted.
Value in () is DC current in STOP mode.
 - OTHERS:**
 - : Signal route.
 - ⊙ : Adjusting point.
 - ▼ (Red) : Measurement point.
 - The ± mark found on some component parts indicates the importance of the safety factor of the parts. Therefore, when replacing, be sure to use parts of identical designation.
 - SWITCHES** (Underline indicates switch position):

- FUNCTION BOARD ASSEMBLY
- S707 : REP
 - S708 : TIME
 - S709 : RAND
 - S710 : EDIT
 - S711 : ▶/||
 - S712 : ■
 - S713 : ▶▶/▶▶
 - S714 : ◀◀/◀◀
 - S716 : O/C
 - S717 : PGM
 - S718 : HI-LITE
 - S751 : POWER

Waveforms

Note: The encircled numbers denote measuring points in the schematic diagram.

- * 1 50T-JUMP: After switching to the pause mode, press the manual search key.
- * 2 FOCUS-IN: Press the key without loading a disc.

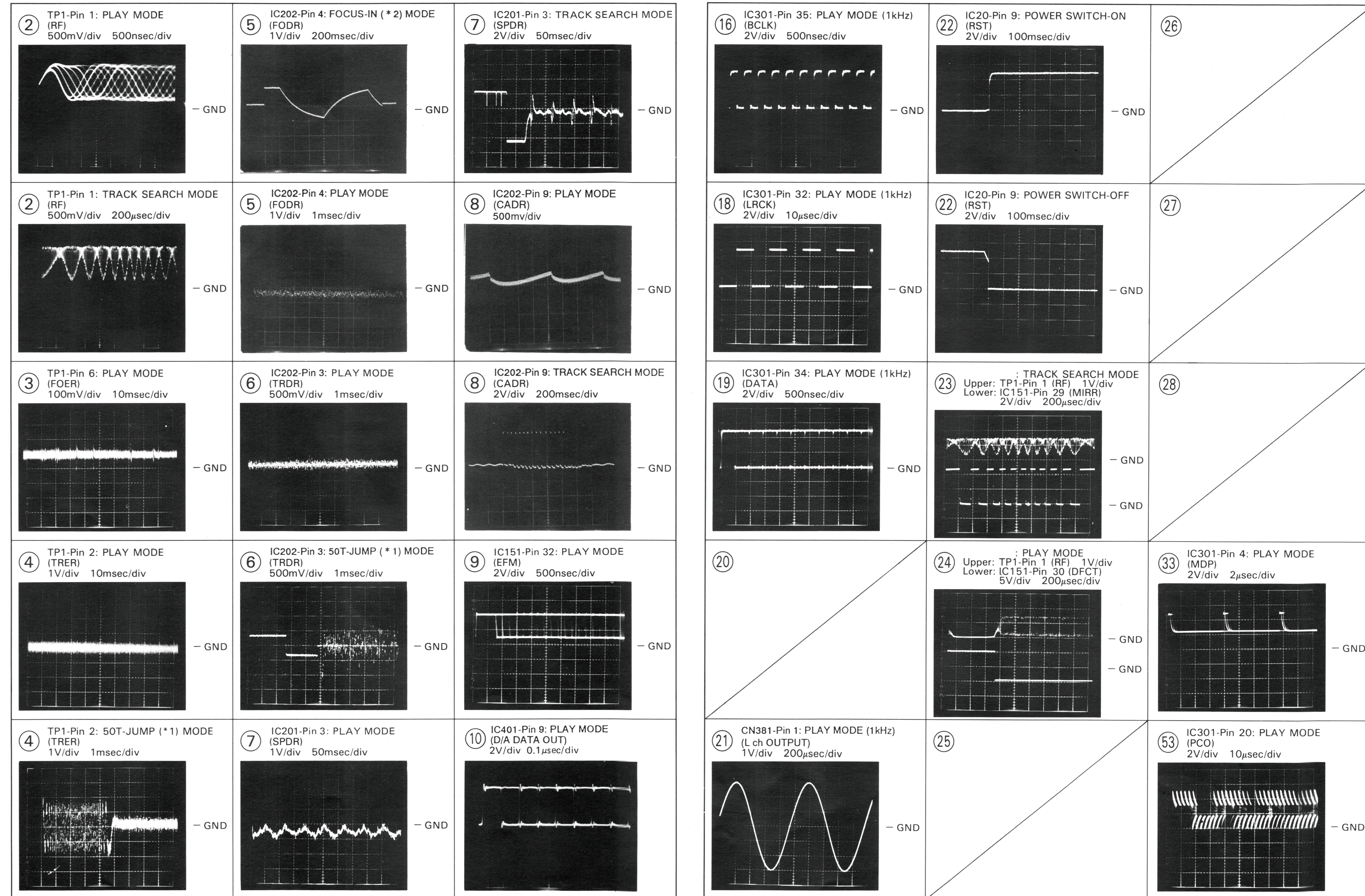

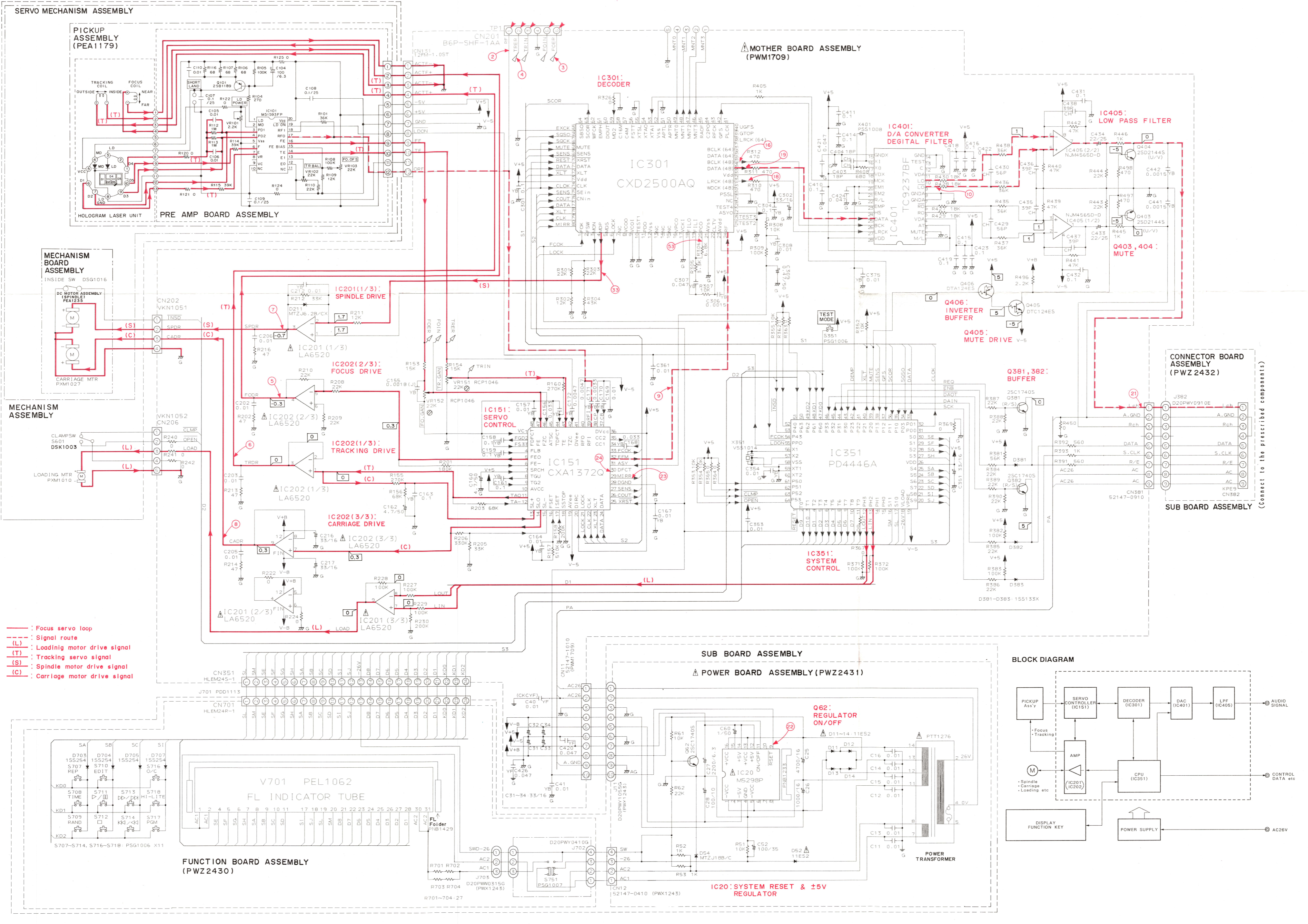

- (T) : Focus servo loop
- (S) : Signal route
- (L) : Loading motor drive signal
- (T) : Tracking servo signal
- (S) : Spindle motor drive signal
- (C) : Carriage motor drive signal

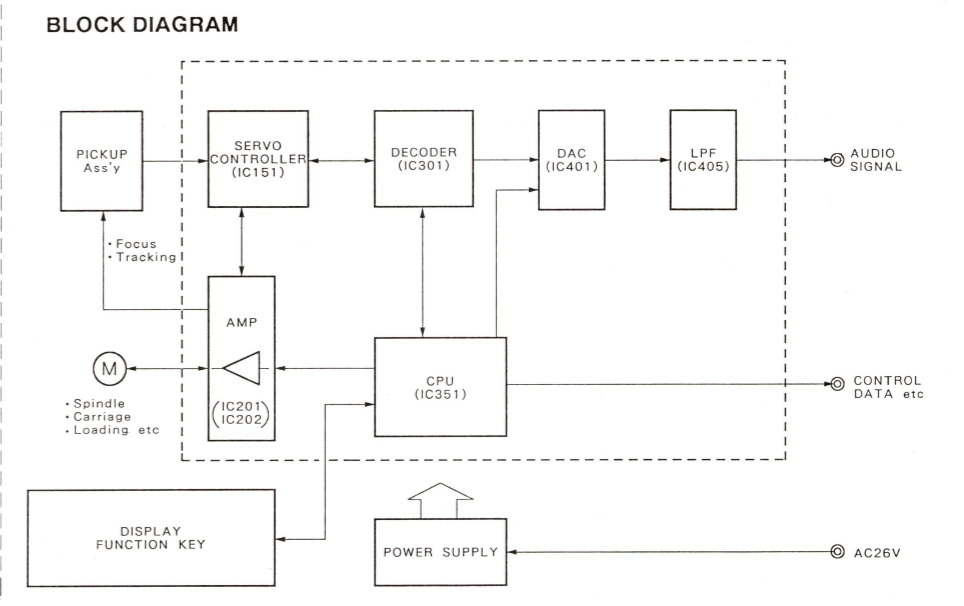

4. PCB CONNECTION DIAGRAM

• View from component side

X1
IC301 (CXD2500AO)

Pin No.	Voltage (V)	Pin No.	Voltage (V)	Pin No.	Voltage (V)	Pin No.	Voltage (V)
1	5.0	21	0	41	NC	61	NC
2	NC	22	2.8	42	5.0	62	NC
3	5.0	23	5.0	43	NC	63	1 to 1.1
4	2.6	24	2.5	44	NC	64	NC
5	0	25	NC	45	NC	65	0
6	5.0	26	0	46	4.4	66	1.8 to 4.8
7	NC	27	2.5	47	0	67	4.9
8	NC	28	0	48	0	68	0
9	0	29	NC	49	0	69	1.1 to 1.1
10	0	30	0	50	NC	70	5.0
11	NC	31	NC	51	NC	71	5.0
12	0	32	2.5	52	0	72	5.0
13	NC	33	5.0	53	2.5	73	5.0
14	NC	34	2.5	54	NC	74	5.0
15	NC	35	2.3	55	0	75	5.0
16	NC	36	NC	56	NC	76	0
17	0	37	NC	57	NC	77	5.0
18	2.8	38	NC	58	NC	78	5.0
19	2.4	39	NC	59	0	79	5.0
20	2.4	40	NC	60	NC	80	0

X3
IC151 (CXA1372Q)

Pin No.	Voltage (V)	Pin No.	Voltage (V)
1	0	25	5.0
2	0	26	0
3	0	27	4.9
4	0	28	0
5	0	29	0
6	0	30	NC
7	0	31	2.5
8	0	32	2.6
9	0	33	4.9
10	5.0	34	-1.7
11	0	35	-1.9
12	0	36	5.0
13	0	37	-0.9
14	1.1 to 1.1	38	-2.1
15	0	39	0
16	-4.0	40	0.9
17	1.2	41	-5.0
18	0	42	0
19	-5.0	43	0
20	5.0	44	0
21	5.0	45	0
22	4.9	46	0
23	5.0	47	0
24	4.9	48	0

X4
IC401 (TC9237BF)

Pin No.	Voltage (V)	Pin No.	Voltage (V)
1	5.0	15	0
2	0	16	2.5
3	5.0	17	2.8
4	5.0	18	5.0
5	2.8	19	3.0
6	2.5	20	0
7	0	21	0
8	0	22	0
9	2.5	23	5.0
10	2.8	24	5.0
11	5.0	25	2.5
12	0	26	2.4
13	NC	27	2.5
14	0	28	5.0

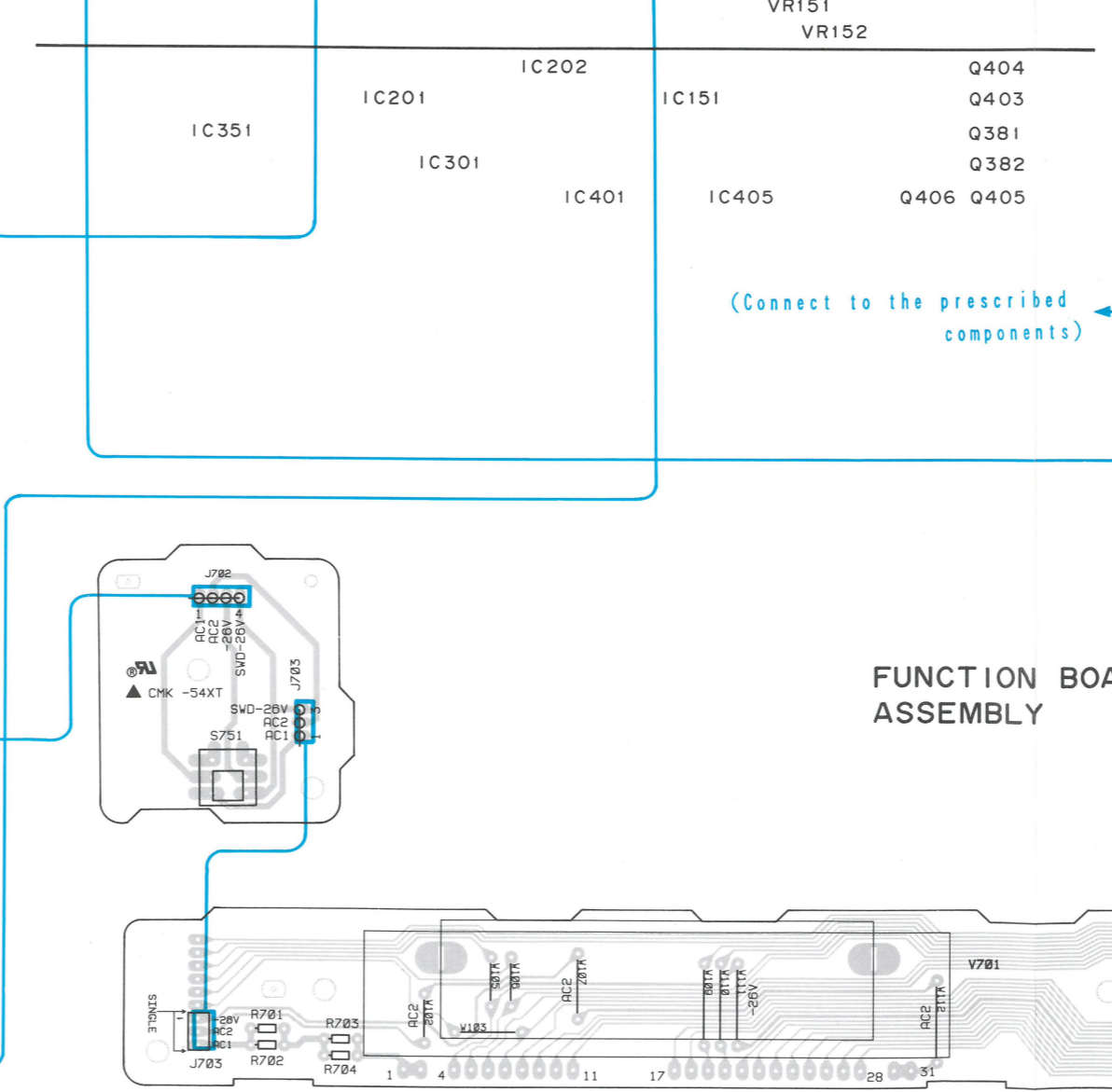
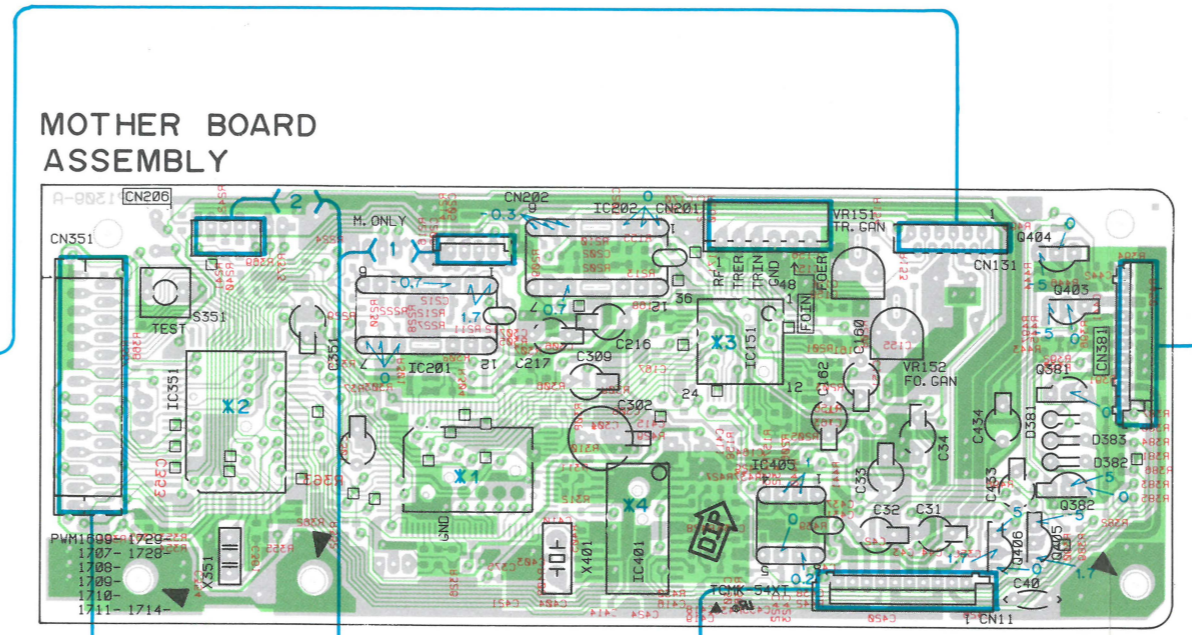
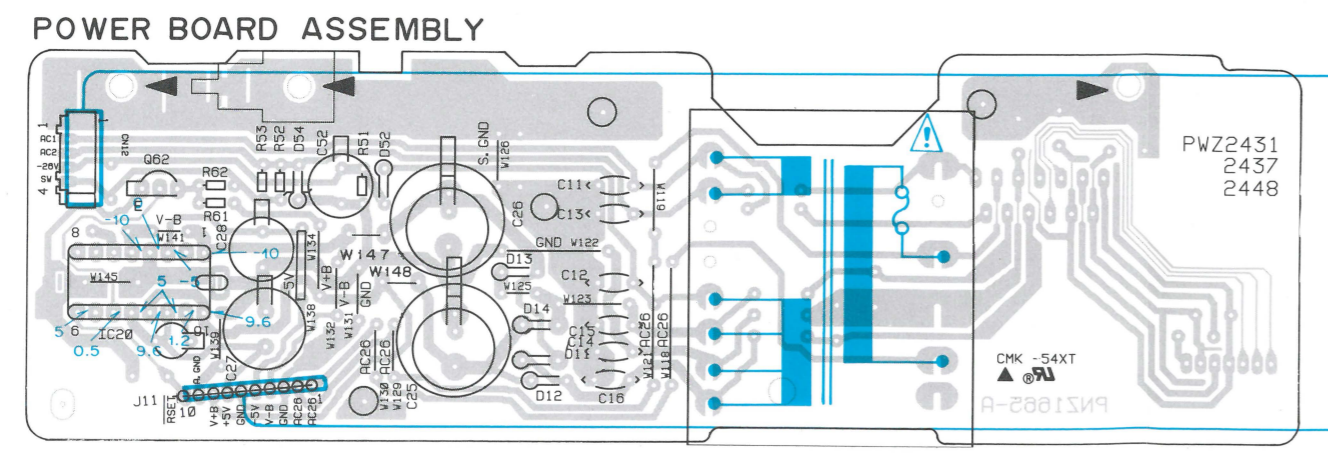
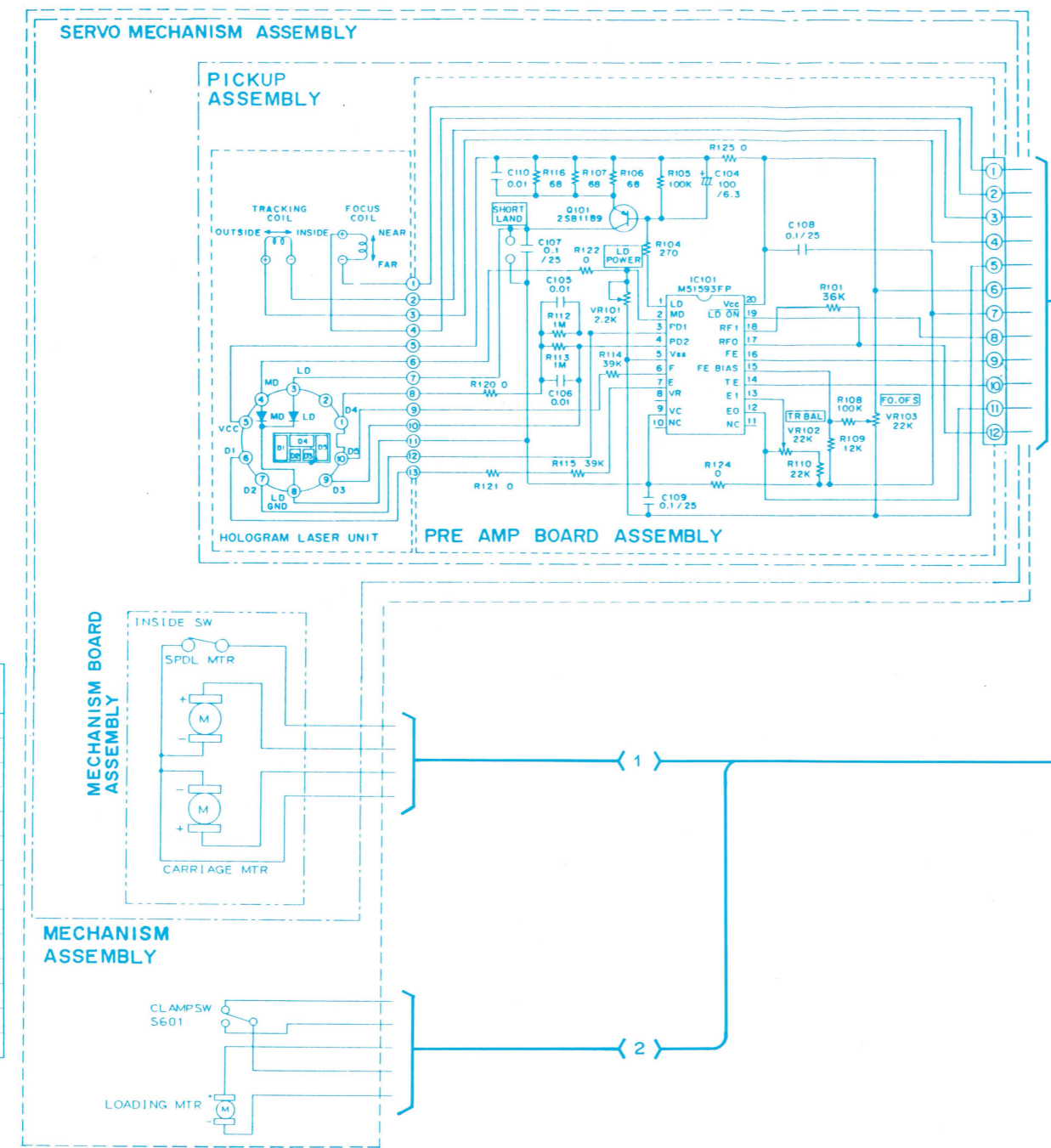

X2
IC351 (PD4446A)

Pin No.	Voltage (V)	Pin No.	Voltage (V)	Pin No.	Voltage (V)	Pin No.	Voltage (V)
1	5.0	17	-1.9 to -1.1	33	5.0	49	0
2	-25.7	18	0	34	1.5 to 4.6	50	NC
3	-25.7	19	-5.0	35	5.0	51	5.0
4	0	20	-19.5	36	0	52	5.0
5	-25.7	21	-19.5	37	5.0	53	5.0
6	-25.7	22	-12.8 to -15.4	38	2.1 to 1.7	54	5.0
7	-25.7	23	-8.8 to -11.1	39	0	55	0
8	-25.7	24	-1.8 to -1.8	40	5.0	56	2.3
9	-25.7	25	-5.9 to -12.7	41	NC	57	2.3
10	-25.7	26	5.0	42	5.0	58	0
11	-25.7	27	-12.3 to -12.1	43	0	59	0
12	0	28	-12.3 to -15.6	44	5.0	60	NC
13	0	29	-15.6 to -11.9	45	4.9	61	5.0
14	NC	30	-15.8 to -21.6	46	0	62	5.0
15	NC	31	0	47	0	63	0
16	-11.0	32	5.0	48	0	64	5.0

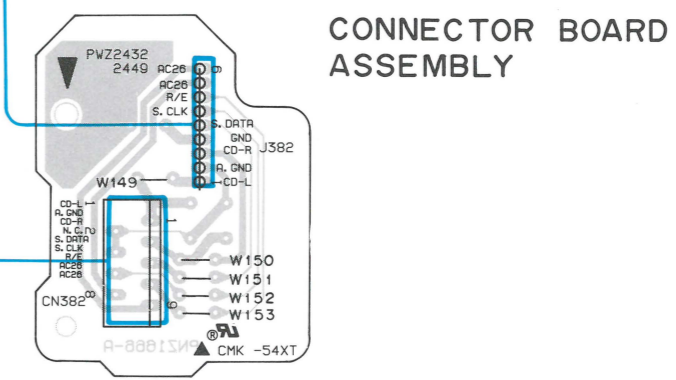

PCB pattern diagram indication	Corresponding part symbol	Part name
		Transistor
		FET
		Diode
		Zener diode
		LED
		Varactor
		Tact switch
		Inductor
		Coil
		Transformer
		Filter
		Ceramic capacitor
		Mylar capacitor
		Styrol capacitor
		Electrolytic capacitor (Non polarized)
		Electrolytic capacitor (Noiseless)
		Electrolytic capacitor (Polarized)
		Electrolytic capacitor (Polarized)
		Power capacitor
		Semi-fixed resistor
		Resistor array
		Resistor
		Resonator
		Thermistor

- This PCB connection diagram is viewed from the parts mounted side.
- The parts which have been mounted on the board can be replaced with those shown with the corresponding wiring symbols listed in the above Table.
- The capacitor terminal marked with shows negative terminal.
- The diode marked with shows cathode side.
- The transistor terminal marked with shows emitter.

4. PCB CONNECTION DIAGRAM

● View from soldering side

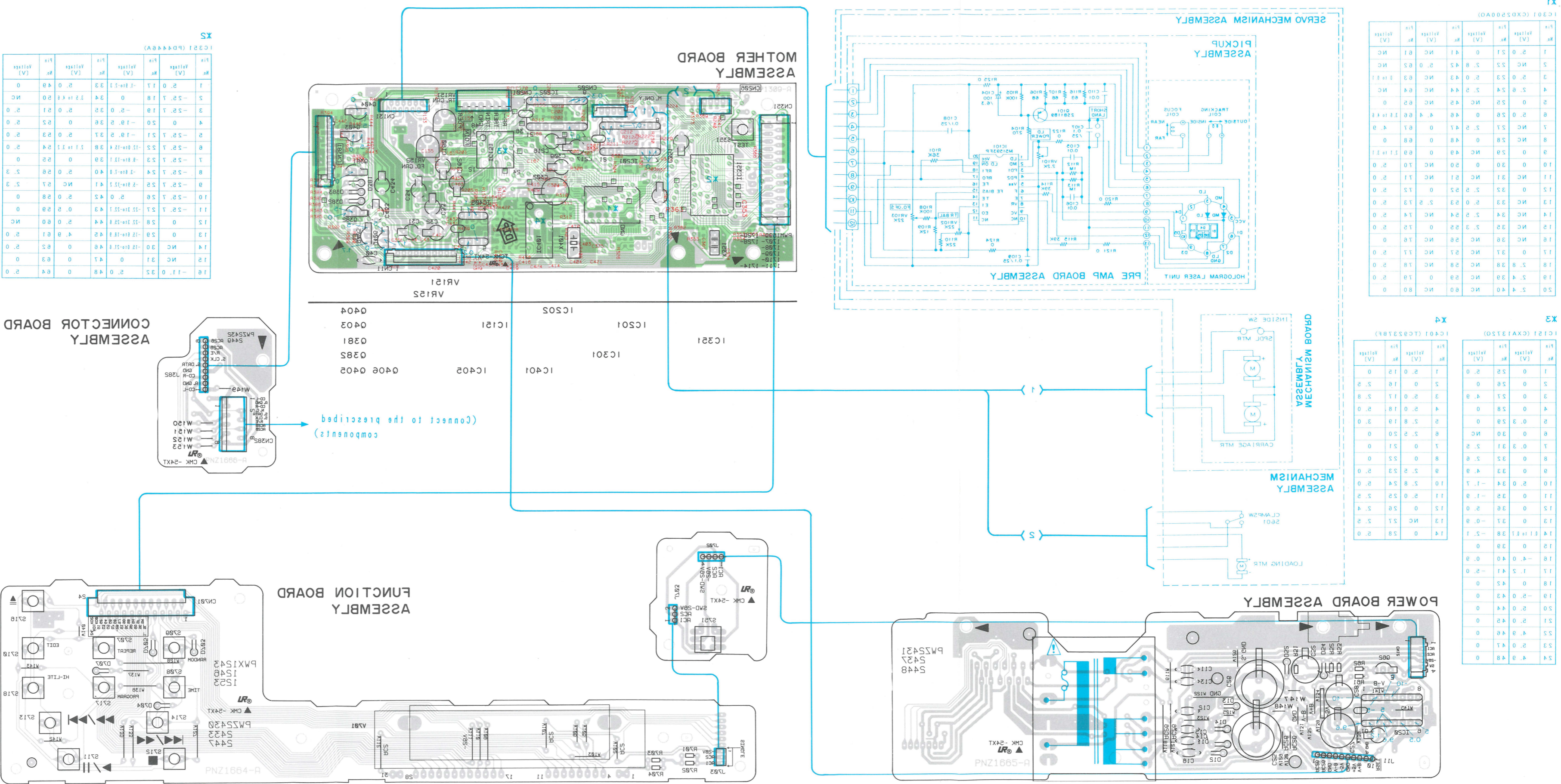

X1

IC301 (CX2500AD)

Pin No.	Pin Voltage [V]	Pin No.	Pin Voltage [V]
1	2.0	21	0
2	NC	22	2.8
3	2.0	23	2.0
4	2.8	24	2.8
5	2.0	25	NC
6	2.0	26	4.4
7	NC	27	2.8
8	2.0	28	4.4
9	2.8	29	2.0
10	2.0	30	2.0
11	NC	31	NC
12	0	32	2.8
13	NC	33	2.8
14	NC	34	2.8
15	NC	35	2.8
16	NC	36	2.8
17	0	37	2.8
18	2.8	38	2.8
19	2.8	39	2.8
20	2.8	40	NC

X3

IC121 (CX17320)

Pin No.	Pin Voltage [V]	Pin No.	Pin Voltage [V]
1	2.0	11	2.0
2	2.8	12	2.0
3	2.0	13	2.8
4	2.8	14	2.0
5	2.0	15	2.8
6	2.8	16	2.0
7	2.0	17	2.8
8	2.8	18	2.0
9	2.0	19	2.8
10	2.8	20	2.0
11	2.0	21	2.8
12	2.8	22	2.0
13	2.0	23	2.8
14	2.8	24	2.0
15	2.0	25	2.8
16	2.8	26	2.0
17	2.0	27	2.8
18	2.8	28	2.0
19	2.0	29	2.8
20	2.8	30	2.0
21	2.0	31	2.8
22	2.8	32	2.0
23	2.0	33	2.8
24	2.8	34	2.0
25	2.0	35	2.8
26	2.8	36	2.0
27	2.0	37	2.8
28	2.8	38	2.0
29	2.0	39	2.8
30	2.8	40	2.0

X4

IC401 (CX2328R)

Pin No.	Pin Voltage [V]	Pin No.	Pin Voltage [V]
1	2.0	11	2.0
2	2.8	12	2.0
3	2.0	13	2.8
4	2.8	14	2.0
5	2.0	15	2.8
6	2.8	16	2.0
7	2.0	17	2.8
8	2.8	18	2.0
9	2.0	19	2.8
10	2.8	20	2.0
11	2.0	21	2.8
12	2.8	22	2.0
13	2.0	23	2.8
14	2.8	24	2.0
15	2.0	25	2.8
16	2.8	26	2.0
17	2.0	27	2.8
18	2.8	28	2.0
19	2.0	29	2.8
20	2.8	30	2.0
21	2.0	31	2.8
22	2.8	32	2.0
23	2.0	33	2.8
24	2.8	34	2.0
25	2.0	35	2.8
26	2.8	36	2.0
27	2.0	37	2.8
28	2.8	38	2.0
29	2.0	39	2.8
30	2.8	40	2.0

X5

IC301 (PD448A)

Pin No.	Pin Voltage [V]	Pin No.	Pin Voltage [V]
1	2.0	17	-1.8
2	-2.8	18	0
3	-2.8	19	-2.0
4	2.0	20	0
5	-2.8	21	-1.8
6	-2.8	22	-1.8
7	-2.8	23	-1.8
8	-2.8	24	-1.8
9	-2.8	25	-1.8
10	-2.8	26	0
11	-2.8	27	-1.8
12	0	28	-1.8
13	0	29	-1.8
14	NC	30	-1.8
15	NC	31	0
16	-1.0	32	2.0

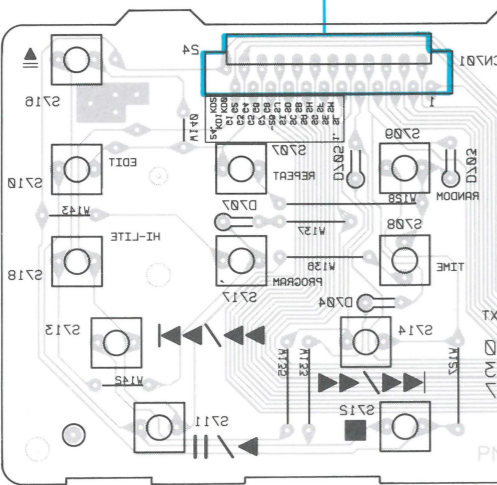
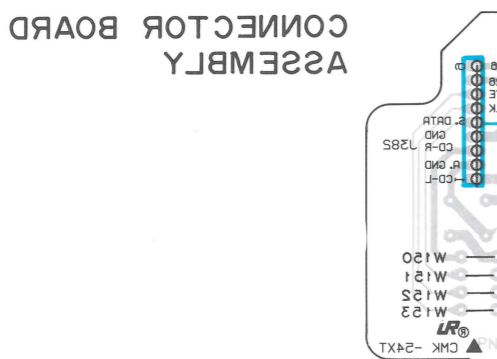

5. PCB PARTS LIST

NOTES:

- Parts marked by "NSP" are generally unavailable because they are not in our Master Spare Parts List.
- The Δ mark found on some component parts indicates the importance of the safety factor of the part. Therefore, when replacing, be sure to use parts of identical designation.
- Parts marked by "⊙" are not always kept in stock. Their delivery time may be longer than usual or they may be unavailable.
- When ordering resistors, first convert resistance values into code form as shown in the following examples.

Ex.1 When there are 2 effective digits (any digit apart from 0), such as 560 ohm and 47k ohm (tolerance is shown by J=5%, and K=10%).

560 Ω \rightarrow $56 \times 10^1 \rightarrow$ 561 RD1/8PM $\boxed{5} \boxed{6} \boxed{1} J$

47k Ω \rightarrow $47 \times 10^3 \rightarrow$ 473 RD1/4PS $\boxed{4} \boxed{7} \boxed{3} J$

0.5 Ω \rightarrow 0R5 RN2H $\boxed{0} \boxed{R} \boxed{5} K$

1 Ω \rightarrow 010 RS1P $\boxed{0} \boxed{1} \boxed{0} K$

Ex.2 When there are 3 effective digits (such as in high precision metal film resistors).

5.62k $\Omega \rightarrow$ $562 \times 10^1 \rightarrow$ 5621 RN1/4PC $\boxed{5} \boxed{6} \boxed{2} \boxed{1} F$

Mark	No.	Description	Part No.	Mark	No.	Description	Part No.
------	-----	-------------	----------	------	-----	-------------	----------

LIST OF ASSEMBLIES

		MOTHER BOARD ASSEMBLY	PWM1709
		FUNCTION BOARD ASSEMBLY	PWZ2430
		POWER BOARD ASSEMBLY	PWZ2431
		CONNECTOR BOARD ASSEMBLY	PWZ2432
NSP		MECHANISM BOARD ASSEMBLY	PWX1192

		C170	CKSQYB332K50
		C156, C168	CKSQYB333K25
		C171, C172	CKSQYB472K50
		C307	CKSQYB473K25
		C41-C44, C202, C203, C205, C206,	CKSQYF103Z50
		C353, C356, C361, C420	
		C410, C411, C414-C416, C418, C419,	CKSQYF104Z25
		C422, C423, C431, C432	
		C421, C424, C426	CKSQYF473Z25

MOTHER BOARD ASSEMBLY

SEMICONDUCTORS

	IC151	CXA1372Q
	IC301	CXD2500AQ
Δ	IC201, IC202	LA6520
	IC405	NJM4565D-D
	IC351	PD4446A

	IC401	TC9237BF
	Q381, Q382	2SC1740S
	Q403, Q404	2SD2144S
	Q406	DTA124ES
	Q405	DTC124ES

	D381-D383	1SS133X
	D211	MTZJ6. 2B

SWITCHES

	S351	PSG1006
--	------	---------

CAPACITORS

	C403, C404	CCSQCH180J50
	C435-C438	CCSQCH390J50
	C429, C430	CCSQCH560J50
	C433, C434	CEAS220M25
	C31-C34, C216, C217, C302, C351	CEAS330M16

	C160, C162	CEAS4R7M50
	C309	CEASR47M50
	C40	CKCYF103Z50
	C157, C164, C167, C169, C212, C308,	CKSQYB103K50
	C354, C375	
	C158, C159, C161, C163, C301, C304	CKSQYB104K25

	C306, C441, C442	CKSQYB152K50
	C155	CKSQYB182K50

RESISTORS

	R222, R224, R240-R242, R326,	RS1/10S000J
	R362-R365, R367, R369, R450, R451	
	VR151, VR152 (R=22K, W=0. 1)	RCP1046
	OTHER RESISTORS	RS1/10S□□□J

OTHERS

	CN131 CONNECTOR	12FM-1. 0BT
	CN201 CONNECTOR	B6P-SHF
	CN351 FFC CONNECTOR 24P	HLEM24S
	X401 CRYSTAL RESONATOR(16. 9344MHz)	PSS1008
	X351 CERAMIC RESONATOR(4. 19MHz)	VSS1014

MECHANISM BOARD ASSEMBLY

SWITCHES

	S610	DSG1016
--	------	---------

FUNCTION BOARD ASSEMBLY

SEMICONDUCTORS

	D703-D705, D707	1SS254
--	-----------------	--------

SWITCHES

	S707-S714, S716-S718	PSG1006
	S751	PSG1007

RESISTORS

	ALL RESISTORS	RD1/6PM□□□J
--	---------------	-------------

OTHERS

	CN701 FFC CONNECTOR 24P	HLEM24R
	V701 FL INDICATOR TUBE	PEL1062

Mark	No.	Description	Part No.
------	-----	-------------	----------

POWER BOARD ASSEMBLY

SEMICONDUCTORS

△	IC20		M5298P
	Q62		2SC1740S
△	D11-D14, D52		11ES2
	D54		MTZJ18B

CAPACITORS

C60		CEAS010M50
C28		CEAS101M10
C52		CEAS101M35
C26		CEAS102M16
C27		CEAS222M6R3
C25		CEAS472M16
C11-C16		CKCYF103Z50

RESISTORS

ALL RESISTORS		RD1/6PM□□□J
---------------	--	-------------

CONNECTOR BOARD ASSEMBLY

OTHERS

CN382 CONNECTOR 9P		KPE9
--------------------	--	------

6. ADJUSTMENTS

● Adjustment Methods

If a disc player is adjusted incorrectly or inadequately, it may malfunction or not work at all even though there is nothing at all wrong with the pickup or the circuitry. Adjust correctly following the adjustment procedure.

● Adjustment Items/Verification Items and Order

If the specified values cannot be obtained or no adjustment is possible by performing the verifications or adjustments described in steps 1 – 4, the pickup block may be defective.

Step	Item	Test Point	Adjustment Location
1	Focus offset verification	TP1, Pin 6(FCS. ERR)	None
2	Tracking error balance verification	TP1, Pin 2(TRK. ERR)	None
3	Pickup radial/tangential direction tilt adjustment	TP1, Pin 1 (RF)	Radial tilt adjustment screw, Tangential tilt adjustment screw
4	RF level verification	TP1, Pin 1 (RF)	None
5	Focus servo loop gain adjustment	TP1, Pin 5(FCS. IN) TP1, Pin 6(FCS. ERR)	VR152 (FCS. GAN)
6	Tracking servo loop gain adjustment	TP1, Pin 3(TRK. IN) TP1, Pin 2(TRK. ERR)	VR151 (TRK. GAN)

● Abbreviation table

FCS. ERR	:Focus Error
TRK. ERR	:Tracking Error
FCS GAN	:Focus Gain
TRK GAN	:Tracking Gain
FCS. IN	:Focus In
TRK. IN	:Tracking In

● Measuring Instruments and Tools

1. Dual trace oscilloscope (10:1 probe)
2. Low-frequency oscillator
3. Test disc (YEDS- 7)
4. 8cm disc (With at least about 20 minutes of recording)
5. Low-pass filter (39k Ω + 0.001 μ F)
6. Resistor (100 k Ω)
7. Ball point hexagon wrench (GGK1002)
8. Standard tools

● Test Point and Adjustment Variable Resistor Positions

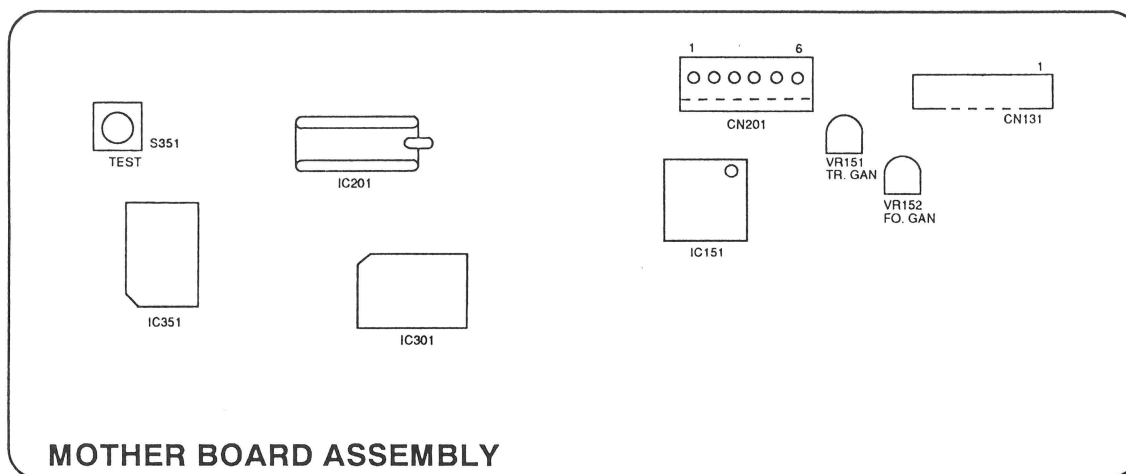

Figure 1 Adjustment Locations

● Notes

1. Use a 10:1 probe for the oscilloscope.
2. All the knob positions (settings) for the oscilloscope in the adjustment procedures are for when a 10:1 probe is used.

● Test Mode

These models have a test mode so that the adjustments and checks required for service can be carried out easily. When these models are in test mode, the keys on the front panel work differently from normal. Adjustments and checks can be carried out by operating these keys with the correct procedure. For these models, all adjustments are carried out in test mode.

[Setting these models to test mode]

How to set this model into test mode.

1. Turn off the power switch.
2. Press the test mode switch (S351). (See Figure 1.)
3. Turn on the power switch.

When the test mode is set correctly, the display is different from what it usually is when the power is turned on. If the display is still the same as usual, test mode has not been set correctly, so repeat Steps 1 – 3.





[Release from test mode]

Here is the procedure for releasing the test mode:

1. Press the STOP key and stop all operations.
2. Turn off the power switch.

[Operations of the keys in test mode]

Code	Key Name	Function in Test Mode	Explanation
	PROGRAM	Focus servo close	<p>The laser diode is lit up and the focus actuator is lowered, then raised slowly and the focus servo is closed at the point where the objective lens is focused on the disc.</p> <p>With the player in this state, if you lightly rotate the stopped disc by hand, you can hear the sound the focus servo.</p> <p>If you can hear this sound, the focus servo is operating correctly. If you press this key with no disc mounted, the laser diode lights up, the focus actuator is pulled down, then the actuator is raised and lowered three times and returned to its original position.</p>
▶/	PLAY/PAUSE	Spindle servo ON	<p>Starts the spindle motor in the clockwise direction and when the disc rotation reaches the prescribed speed (about 500 rpm at the inner periphery), sets the spindle servo in a closed loop.</p> <p>Be careful. Pressing this key when there is no disc mounted makes the spindle motor run at the maximum speed.</p> <p>If the focus servo does not go correctly into a closed loop or the laser light shines on the mirror section at the outermost periphery of the disc, the same symptom is occurred.</p>
▶/	PLAY/PAUSE	Tracking servo close/open	<p>Pressing this key when the focus servo and spindle servo are operating correctly in closed loops puts the tracking servo into a closed loop, displays the track number being played back and the elapsed time on the front panel, and outputs the playback signal.</p> <p>If the elapsed time is not displayed or not counted correctly or the audio is not played back correctly, it may be that the laser is shining on the section with no sound recorded at the outer edge of the disc, that something is out of adjustment, or that there is some other problem.</p> <p>This key is a toggle key and open/close the tracking servo alternately. This key has no effect if no disc is mounted.</p>

Code	Key Name	Function in Test Mode	Explanation
	MANUAL TRACK SEARCH REV	Carriage reverse (inwards)	Moves the pickup position toward the inner diameter of the disc. When this key is pressed with the tracking servo in a closed loop, the tracking servo automatically goes into an open loop. Since the motor does not automatically stop at the mechanical end point in test mode, be careful with this operation.
	MANUAL TRACK SEARCH FWD	Carriage forward (outwards)	Moves the pickup position toward the outer diameter of the disc. When this key is pressed with the tracking servo in a closed loop, the tracking servo automatically goes into an open loop. Since the motor does not automatically stop at the mechanical end point in test mode, be careful with this operation.
	STOP	Stop	Switches off all the servos and initialized. The pickup remains where it was when this key was pressed.
	OPEN/CLOSE	Disc tray open/close	Open/close the disc tray. This key is a toggle key and open/close tray alternately. Pressing this key when the disc is turning stops the disc, then opens the tray. This key operation does not affect the position of the pickup.

[How to play back a disc in test mode]

In test mode, since the servos operate independently, playing back a disc requires that you operate the keys in the correct order to close the servos.

Here is the key operation sequence for playing back a disc in test mode.

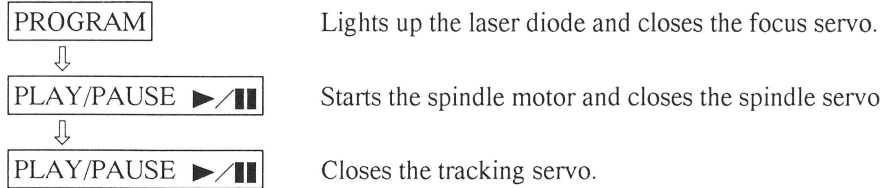

Wait at least 2-3 seconds between each of these operations.

1. Focus Offset Verification

● Objective	Verify the DC offset for the focus error amp.		
● Symptom when out of adjustment	The model does not focus in and the RF signal is dirty.		
● Measurement instrument connections	Connect the oscilloscope to TP1, Pin 6 (FCS. ERR) [Settings] 5 mV/division 10 ms/division DC mode	● Player state	Test mode, stopped (just the Power switch on)
		● Adjustment location	None
		● Disc	None needed
[Procedure]			
Verify the DC voltage at TP1, Pin 6 (FCS. ERR) is 0 ± 50 mV.			

Note : If the specified values cannot be obtained or no adjustment is possible by performing the verifications or adjustments described in adjustment items 1 – 4, the pickup block may be defective.

2. Tracking Error Balance Verification

<ul style="list-style-type: none"> ● Objective ● Symptom when out of adjustment 	To verify that there is no variation in the sensitivity of the tracking photo diode. Play does not start or track search is impossible.		
<ul style="list-style-type: none"> ● Measurement instrument connections 	Connect the oscilloscope to TP1, Pin 2 (TRK. ERR). This connection may be via a low pass filter. [Settings] 50 mV/division 5 ms/division DC mode	<ul style="list-style-type: none"> ● Player state ● Adjustment location ● Disc 	Test mode, focus and spindle servos closed and tracking servo open None YEDS-7

[Procedure]

1. Move the pickup to midway across the disc (R=35 mm) with the MANUAL TRACK SEARCH FWD **▶▶ • ▶▶** or **◀◀ • ◀◀** key.
2. Press the PROGRAM key, then the PLAY/PAUSE **▶/||** key in that order to close the focus servo then the spindle servo.
3. Line up the bright line (ground) at the center of the oscilloscope screen and put the oscilloscope into DC mode.
4. Supposing that the positive amplitude of the tracking error signal at TP1, pin 2 (TRK ERR) is (A) and the negative amplitude is (B), the following expression is satisfied.

$$\text{When } A \geq B, \frac{A-B}{C} \times \frac{1}{2} \leq 0.1$$

$$\text{When } A < B, \frac{B-A}{C} \times \frac{1}{2} \leq 0.1$$

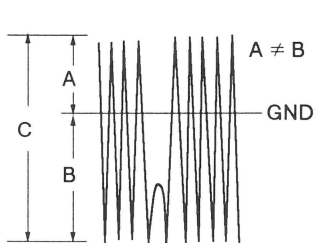

When there is a DC component

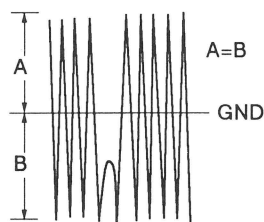

When there is no DC component

3. Pickup Radial/Tangential Tilt Adjustment

<ul style="list-style-type: none"> ● Objective ● Symptom when out of adjustment 	<p>To adjust the angle of the pickup relative to the disc so that the laser beams are shone straight down into the disc for the best read out of the RF signals.</p> <p>Sound broken;some discs can be played but not others.</p>		
<ul style="list-style-type: none"> ● Measurement instrument connections 	<p>Connect the oscilloscope to TP1, Pin 1 (RF).</p> <p>[Settings] 20 mV/division 200 ns/division AC mode</p>	<ul style="list-style-type: none"> ● Player state ● Adjustment location ● Disc 	<p>Test mode, play</p> <p>Pickup radial tilt adjustment screw and tangential tilt adjustment screw</p> <p>8 cm disc (However, those with approx. 20 min of audio signal (music).)</p>

[Procedure]

1. Press the MANUAL TRACK SEARCH FWD ►► • ►► or ◀◀ • ◀◀ key to move the pickup to the external circumference of the disc.
Press the PROGRAM key, the PLAY/PAUSE ►/|| key, then the PLAY/PAUSE ►/|| key in that order to close the respective servos and put the player into play mode.
2. First, adjust the radial tilt adjustment screw with the hexagon wrench (GGK1002) so that the eye pattern (the diamond shape at the center of the RF signal) can be seen the most clearly.
3. Next, adjust the tangential tilt adjustment screw with the hexagon wrench (GGK1002) so that the eye pattern (the diamond shape at the center of the RF signal) can be seen the most clearly (Figure 3).
※ The ball-point type hexagonal wrench is used because the disc will get in the way if a normal hexagonal wrench is used.
4. Adjust the radial tilt adjustment screw and the tangential tilt adjustment screw again so that the eye pattern can be seen the most clearly. As necessary, adjust the two screws alternately so that the eye pattern can be seen the most clearly.
5. When the adjustment is completed, lock the radial and tangential adjustment screw.

Note:Radial and tangential mean the directions relative to the disc shown in Figure 2.

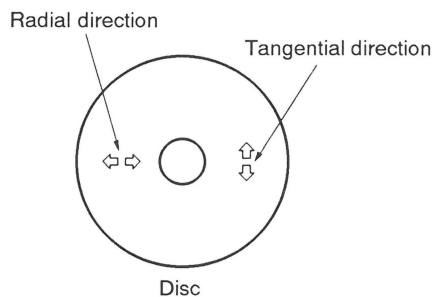
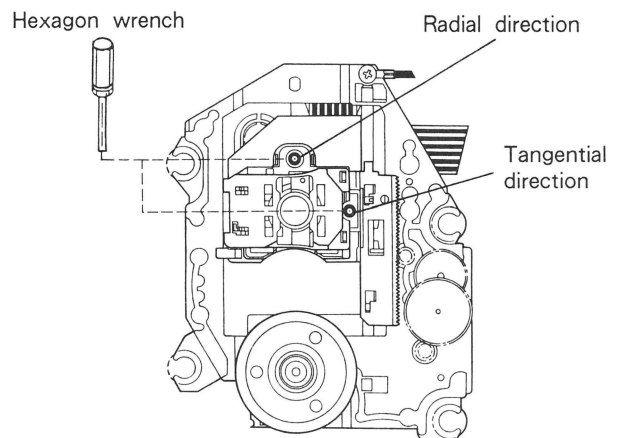

Figure 2



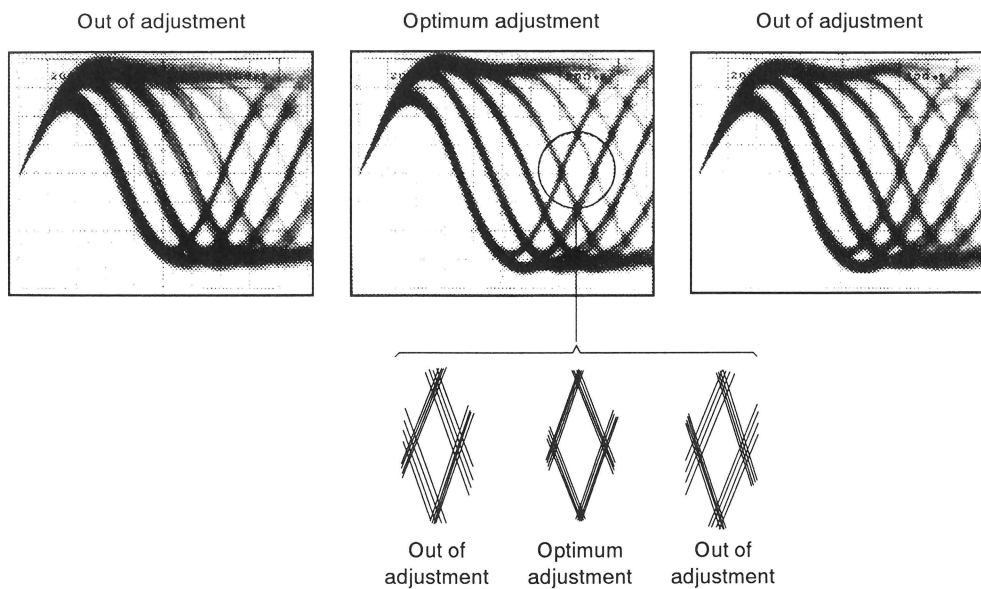

Figure 3 Eye pattern

4. RF Level Verification

<ul style="list-style-type: none"> ● Objective 	To verify the playback RF signal amplitude		
<ul style="list-style-type: none"> ● Symptom when out of adjustment 	No play or no search		
<ul style="list-style-type: none"> ● Measurement instrument connections 	Connect the oscilloscope to TPI, Pin 1 (RF). [Settings] 50 mV/division 10 ms/division AC mode	<ul style="list-style-type: none"> ● Player state ● Adjustment location ● Disc 	Test mode, play None YEDS-7

[Procedure]

1. Move the pickup to midway across the disc (R=35 mm) with the MANUAL TRACK SEARCH FWD **▶▶ • ▶▶** or **◀◀ • ◀◀** key, then press the PROGRAM key, the PLAY/PAUSE **▶/||** key, then the PLAY/PAUSE **▶/||** key in that order to close the respective servos and put the player into play mode.
2. Verify the RF signal amplitude is $1.2 V_{p-p} \pm 0.2 V$.

5. Focus Servo Loop Gain Adjustment

● Objective	To optimize the focus servo loop gain.		
● Symptom when out of adjustment	Playback does not start or focus actuator noisy.		
● Measurement instrument connections	See figure 4.	● Player state	Test mode, play
	[Settings] CH1 CH2 20 mV/division 5 mV/division X-Y mode	● Adjustment location	VR152 (FCS. GAN)
		● Disc	YEDS-7

[Procedure]

1. Set the AF generator output to 1.2 kHz and 1 Vp-p.
2. Press the MANUAL TRACK SEARCH FWD ►► • ►► or ◀◀ • ◀◀ key to move the pickup to halfway across the disc (R=35 mm), then press the PROGRAM key, the PLAY/PAUSE ►/|| key, then the PLAY/PAUSE ►/|| key in that order to close the corresponding servos and put the player into play mode.
3. Adjust VR152 (FCS. GAN) so that the Lissajous waveform is symmetrical about the X axis and the Y axis.

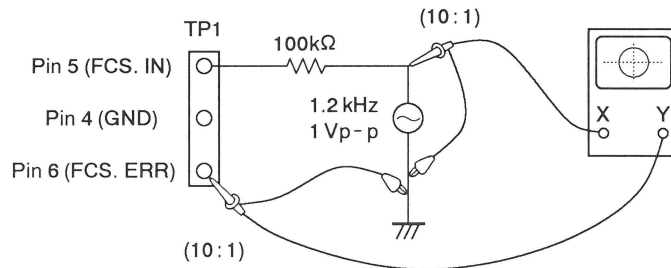
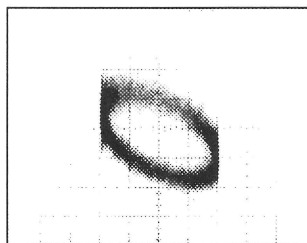
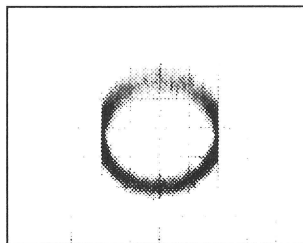

Figure 4

Focus Gain Adjustment



Higher gain



Optimum gain

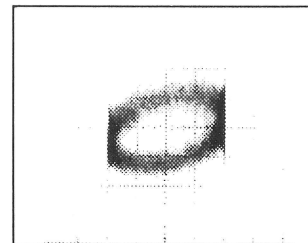

Lower gain

7. FOR ABXK AND ADL TYPES

CONTRAST OF MISCELLANEOUS PARTS

NOTES:

- Parts marked by “NSP” are generally unavailable because they are not in our Master Spare Parts List.
- The Δ mark found on some component parts indicates the importance of the safety factor of the part. Therefore, when replacing, be sure to use parts of identical designation.
- Parts marked by “ \odot ” are not always kept in stock. Their delivery time may be longer than usual or they may be unavailable.

PD-J410/ABXK, ADL and AEMXK have the same construction except for the following:

Mark	Symbol & Description	Part No.			Remarks
		AEMXK type	ABXK type	ADL type	
NSP	Power knob	PAC1733	PAC1733	RAC1750	
	Under base	PNA1901	PNA1901	PNA1967	
NSP	Rear base	PNA1909	PNA1926	PNA1927	
	Packing case	PHG1861	PHG1861	PHG1879	
	Operating instructions (English/French/German/Italian/Dutch/ Swedish/Spanish/Portuguese)	PRE1174	
	Operating instructions (Ennglish)	PRB1185	PRB1185	

8. SPECIFICATIONS

Type Compact disc digital audio system
 Discs used Compact disc
 Frequency response 4 Hz to 20 kHz
 Number of channels 2 channel (stereo)

Other

Dimensions 360 (W) x 90.5 (H) x 325 (D) mm
 Weight 3.1 kg

Accessories

Operating instructions 1

NOTE:

The specifications and design of this product are subject to change without notice, due to improvements.

9. PANEL FACILITIES

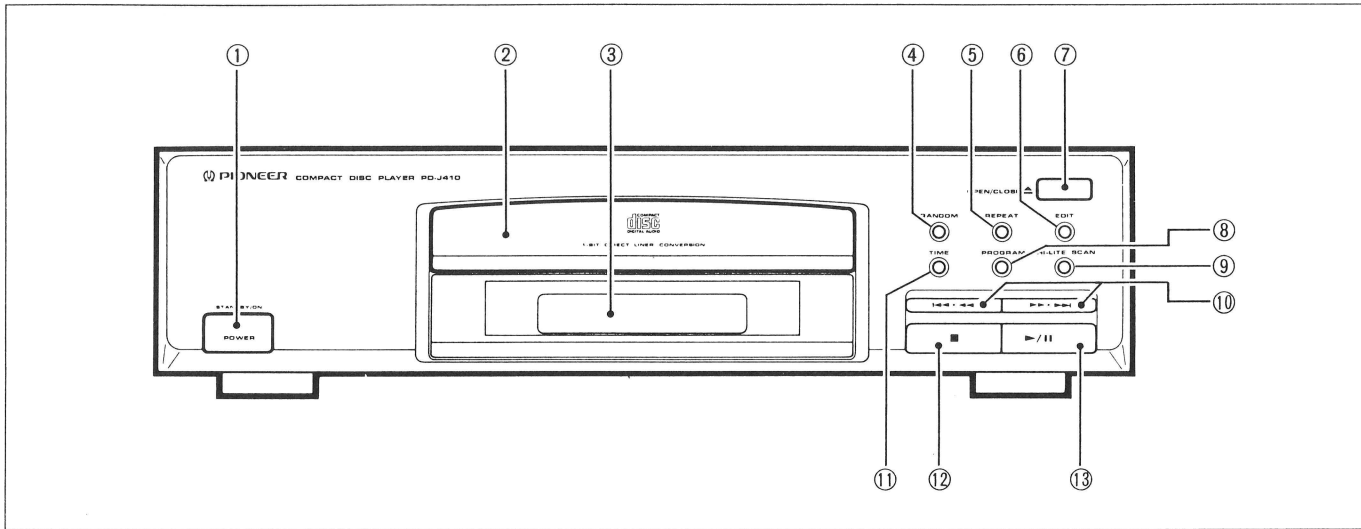

FRONT PANEL

① POWER STANDBY/ON switch

Press to turn power to the unit ON and STANDBY.

② DISC tray

This is where the disc is set. When power is switched ON and OPEN/CLOSE button is pressed, the tray opens to the front. To close the tray, press the OPEN/CLOSE button, or lightly push the ejected tray.

③ Display

④ RANDOM button

Press to begin random playback.

⑤ REPEAT button

Press this button for repeat playback. Pressing the button once, twice, or three times will change the repeat mode from single track repeat, all tracks repeat, to repeat playback cancellation respectively.

⑥ EDIT button

With this button you can automatically record (edit) from a CD to match the length of the tape. For more details, see the operating instructions supplied with the amplifier.

⑦ OPEN/CLOSE button (⬆)

Press when you wish to eject or load a disc. Each time the button is pressed, the tray alternately opens and closes.

⑧ PROGRAM button

Use to program a sequence of tracks.

- Press this button after selecting a desired track with the Track search buttons. Tracks will be added to the program in the order in which they are specified.

⑨ HI-LITE SCAN button

Every track of a CD is played back for 10 seconds, starting at a point one minute from the beginning of each song. To set a new starting time for HI-LITE SCAN, press the HI-LITE SCAN button at any desired point during playback of a track. This point will be set as the new starting time. After that, each track is played back for 10 seconds beginning at the new starting time.

⑩ Manual/Track search buttons (|◀◀ · ◀◀, ▶▶ · ▶▶|)

To perform track search in normal playback, programmed playback or PAUSE mode. You can advance to the next track or go back to the previous one by using the Manual/Track search buttons. The Fast forward or fast reverse function will be activated by holding down these buttons.

⑪ TIME button

This button selects the display mode of the indicator panel. Each time the button is pressed, the indication changes from TIME, REMAIN, to TOTAL in that order.

⑫ Stop button (■)

Press to stop playback. Press to clear a program. When pressed, the player goes into stop mode and all operations stop. When pressed during stop mode, the program stored in memory is cleared.

⑬ Play/Pause button (▶/||)

When the CD player is paused or stopped, press to resume play or begin play.

If pressed during play, this temporarily interrupts play.

