

Website: <http://www.LGService.com> [For U.S.A]  
[www.lg.ca](http://www.lg.ca) [For CANADA]  
E-mail: <http://www.LGService.com/techsup.html>

# WASHING MACHINE SERVICE MANUAL

## ▲ CAUTION

READ THIS MANUAL CAREFULLY TO DIAGNOSE  
PROBLEMS CORRECTLY BEFORE SERVICING THE UNIT.

**MODEL: WM3431H\*/WM3434H\***  
**WD-1431(1~6)RD(K)/WD-14316RD**



JAN. 2005 PRINTED IN KOREA

P/No.:3828ER3035Q

---

# CONTENTS

1. SPECIFICATIONS .....	3
2. FEATURES & TECHNICAL EXPLANATION .....	4
3. PARTS IDENTIFICATION .....	6
4. INSTALLATION & TEST .....	7
5. OPERATION .....	10
6. WIRING DIAGRAM/PROGRAM CHART .....	12
7. TROUBLESHOOTING .....	14
7-1. BEFORE PERFORMING SERVICE .....	14
7-2. QC TEST MODE .....	14
7-3. HOW TO CHECK THE WATER LEVEL FREQUENCY .....	14
7-4. ERROR DISPLAY .....	15
8. ERROR DIAGNOSIS AND CHECK LIST .....	17
8-1. DIAGNOSIS AND SOLUTION FOR ABNORMAL OPERATION .....	17
8-2. FAULT DIAGNOSIS AND TROUBLESHOOTING .....	20
9. DISASSEMBLY INSTRUCTIONS .....	30
10. EXPLODED VIEW .....	39
10-1. CABINET & CABINET COVER ASSEMBLY .....	39
10-2. CONTROL PANEL & DISPENSER ASSEMBLY .....	40
10-3. DRUM & TUB ASSEMBLY .....	41
10-4. DRYER .....	42

# 1. SPECIFICATION

ITEM		WM3431H*, WD-14312RD, WD-14316RD	WM3434H*
POWER SUPPLY		AC 120 V, 60 Hz	
PRODUCT WEIGHT		147 lbs. (68 kg)	
ELECTRIC POWER CONSUMPTION	WASHING	140 W	
	SPIN	410 W	
	FAN MOTOR	25 W	
	DRAIN MOTOR	80 W	
	WASH HEATER	1000 W	
	DRY HEATER	1200 W	
REVOLUTION SPEED	WASH	50 rpm	
	SPIN	0-1400 rpm	0-1200 rpm
OPERATIONAL WATER PRESSURE		4.5-145 psi (30-1000 kPa)	
CONTROL TYPE		Electronic	
WASH CAPACITY		2.11 cu. ft	
DRY CAPACITY		8 <sup>13</sup> / <sub>16</sub> lbs. (4 kg)	
DIMENSIONS		23 <sup>3</sup> / <sub>8</sub> " (W) X 25 <sup>3</sup> / <sub>8</sub> " (D) X 33 <sup>1</sup> / <sub>4</sub> " (H)	
CYCLES		9	
WASH/RINSE TEMPERATURES		5	
SPIN SPEEDS		5	
OPTIONS		Soak, Extra Wash, Rinse+Spin, Spin Only, Dry Only, Delay Wash, Extra Rinse	
DELAY WASH		up to 19 hours	
DOOR SWITCH TYPE		Bi-Metal	
WATER LEVEL		10 steps (by sensor)	
LAUNDRY LOAD SENSING		Incorporated	
ERROR DIAGNOSIS		Incorporated	
POWER AUTO OFF		Incorporated	
CHILD LOCK		Incorporated	
AUTO RESTART		Incorporated	

## 2. FEATURES & TECHNICAL EXPLANATION

---

### 2-1.FEATURES



#### ■ **Automatic Process From Washing To Drying**

Automatic process from washing to drying can be selected easily.

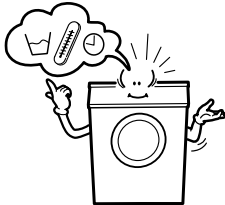

#### ■ **More economical by using Intelligent Wash System**

Intelligent Wash System detects the amount of load and water temperature, and then determines the optimum water level and washing time to minimize energy and water consumption.

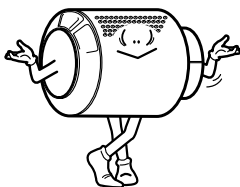

#### ■ **Direct Drive System**

The advanced Brushless DC motor directly drives the drum without belt and pulley.



#### ■ **Child-Lock**

The Child-Lock prevents children from pressing any button to change the settings during operation.



#### ■ **Built-in Heater**

Internal heater automatically heats the water to the optimal temperature on selected cycles.

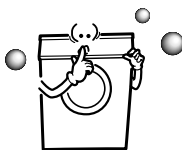

#### ■ **Low noise speed control system**

By sensing the amount of load and balance, it evenly distributes load to minimize the spinning noise level.

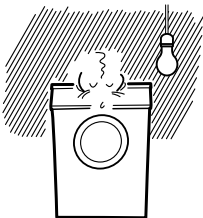

#### ■ **Auto Restart**

If the washing machine is turned off by a power failure, it will restart automatically from the position it stopped.

---

## 2-2. NEURO FUZZY WASHING TIME OPTIMIZATION

To get the best washing performance, optimal time is determined by the water temperature, the selected washing temperature, and the size of the load.

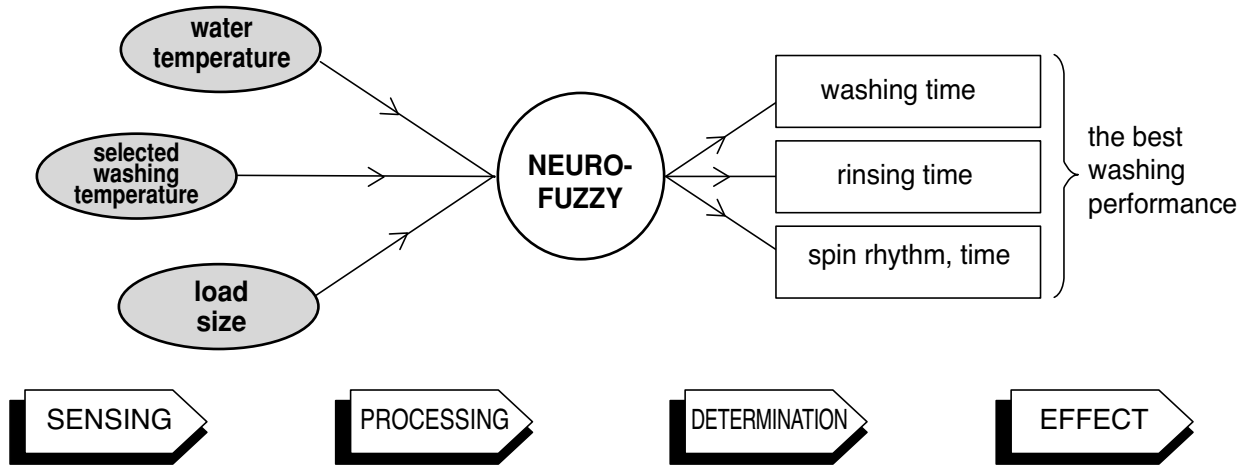

## 2-3. WATER LEVEL CONTROL

- This model incorporates a pressure sensor which can sense the water level in the tub.
- The water supply is stopped when the water level reaches the preset level, the washing program then proceeds.
- Spinning does not proceed until the water in the tub drains to a certain level.

# 3. PARTS IDENTIFICATION

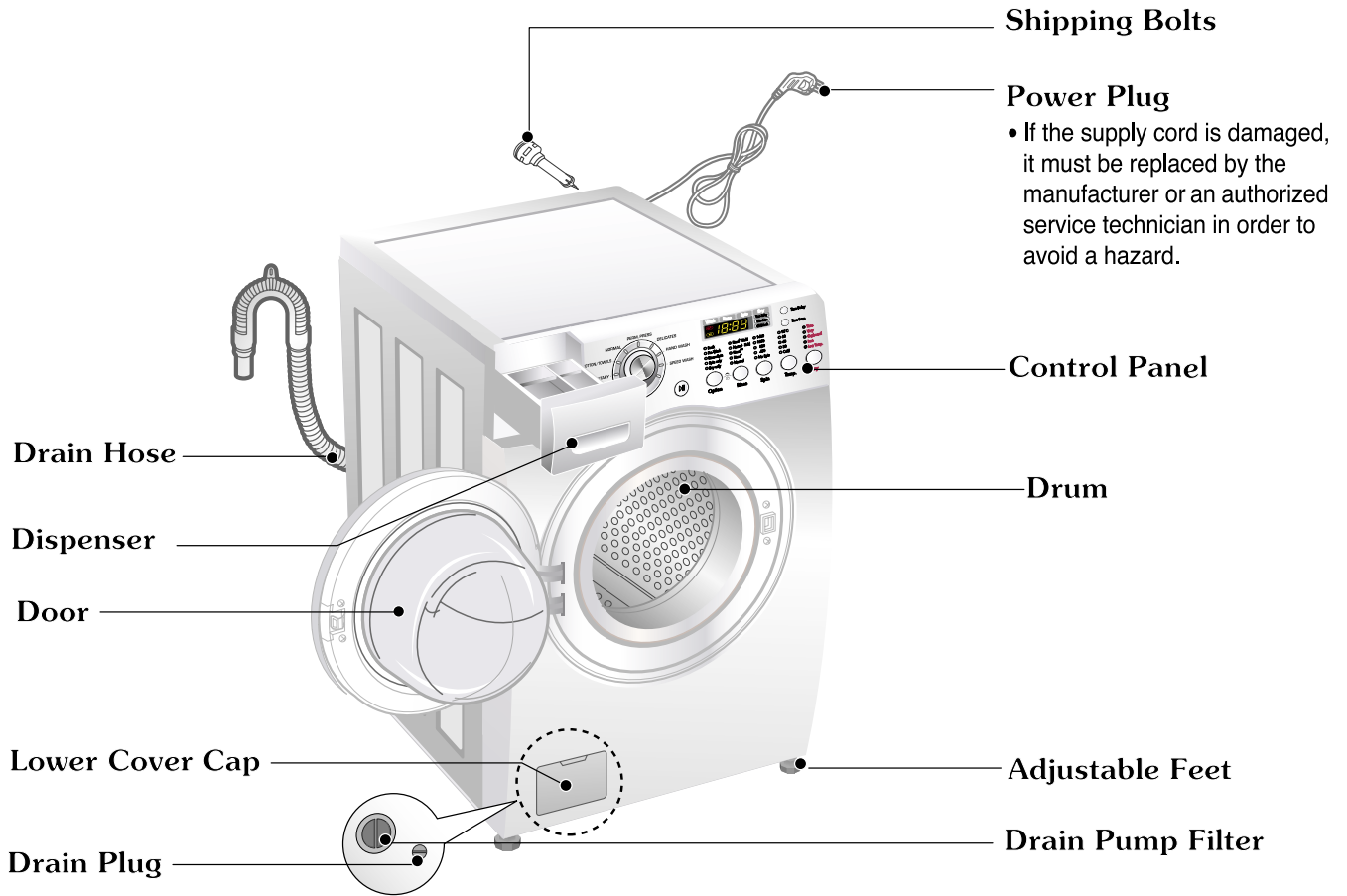

## ■ ACCESSORIES

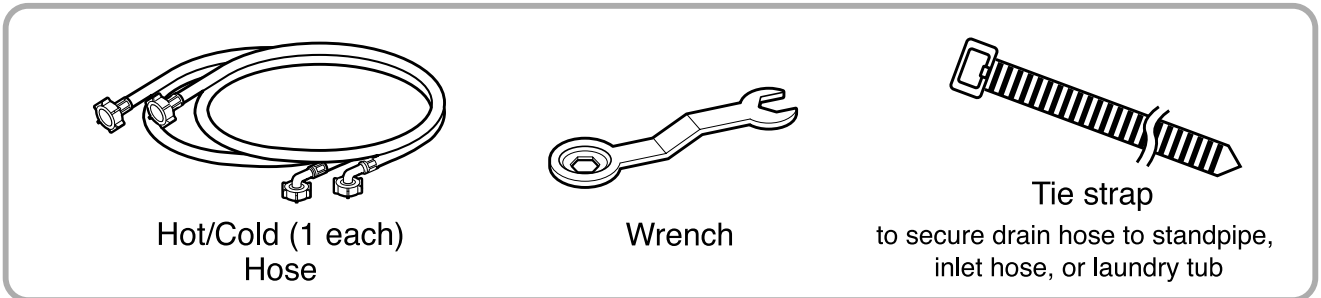

## 4. INSTALLATION & TEST

- ① Before servicing, ask the customer what the trouble is.
- ② Check the setup (power supply is 120 V AC, remove the transit bolts....).
- ③ Check with the troubleshooting guide.
- ④ Plan your service method by referring to the disassembly instructions.
- ⑤ Service the unit.
- ⑥ After servicing, operate the appliance to see whether it functions correctly.

### ■ STANDARD INSTALLATION

The appliance should be installed as follows:

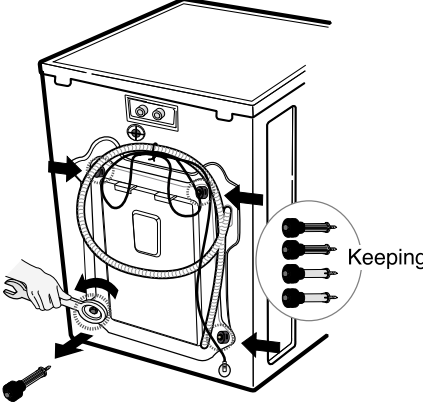
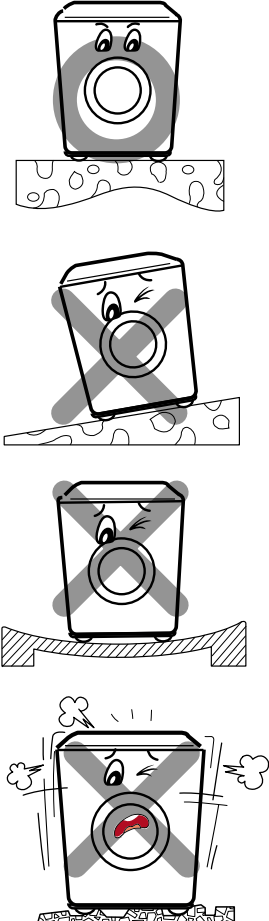
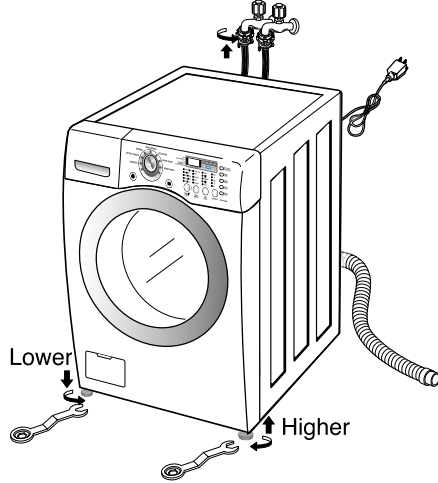
REMOVE THE SHIPPING BOLTS	INSTALL THE APPLIANCE ON A FLAT AND FIRM SURFACE	ADJUST THE LEVELING
<ul style="list-style-type: none"> <li>• Remove the 4 shipping bolts with the supplied wrench.</li> <li>※ Do lower bolts first remove easily.</li> <li>• Keep the shipping bolts and wrench for future use.</li> <li>• Insert the 4 caps (provided) into the hole.</li> </ul> 		<ul style="list-style-type: none"> <li>• Turn the leveling feet to adjust the appliance.</li> </ul>  <ul style="list-style-type: none"> <li>• Turn clockwise to raise; counterclockwise to lower.</li> </ul>

## ■ HOW TO CONNECT THE INLET HOSE

- Verify that the rubber washer is inside of the valve connector.
- Tighten the inlet hose securely to prevent leaks.

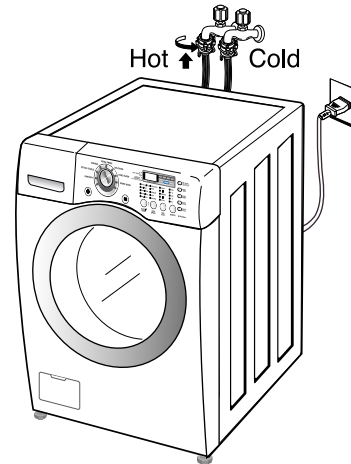

## ■ CONNECT THE DRAIN HOSE

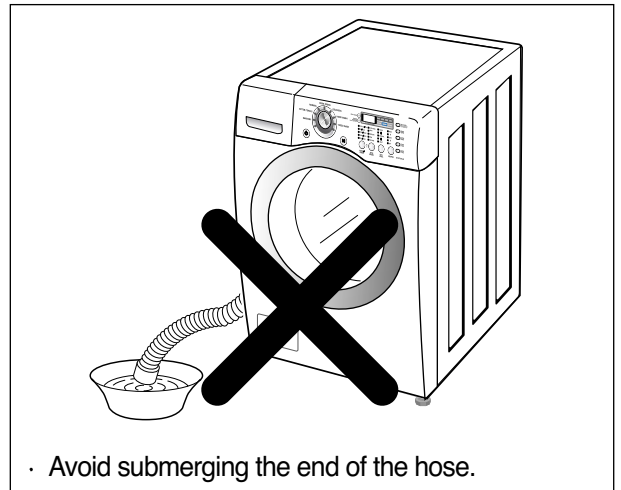
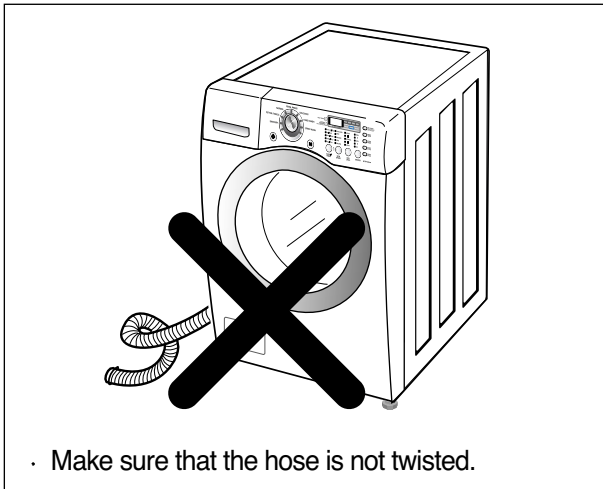

※ The end of the drain hose should be placed less than 96" from the floor.

## ■ CONNECT POWER PLUG

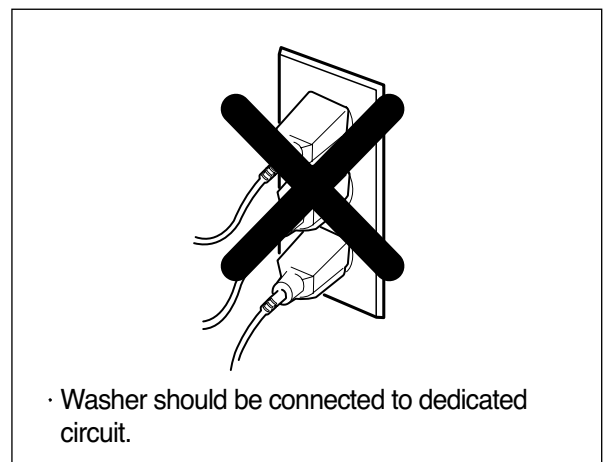
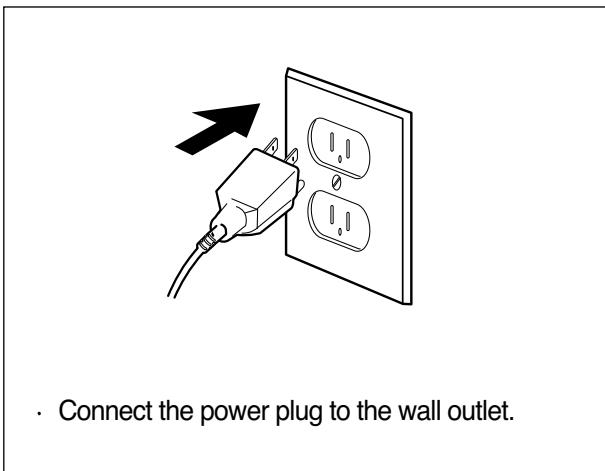

## 7 TEST OPERATION

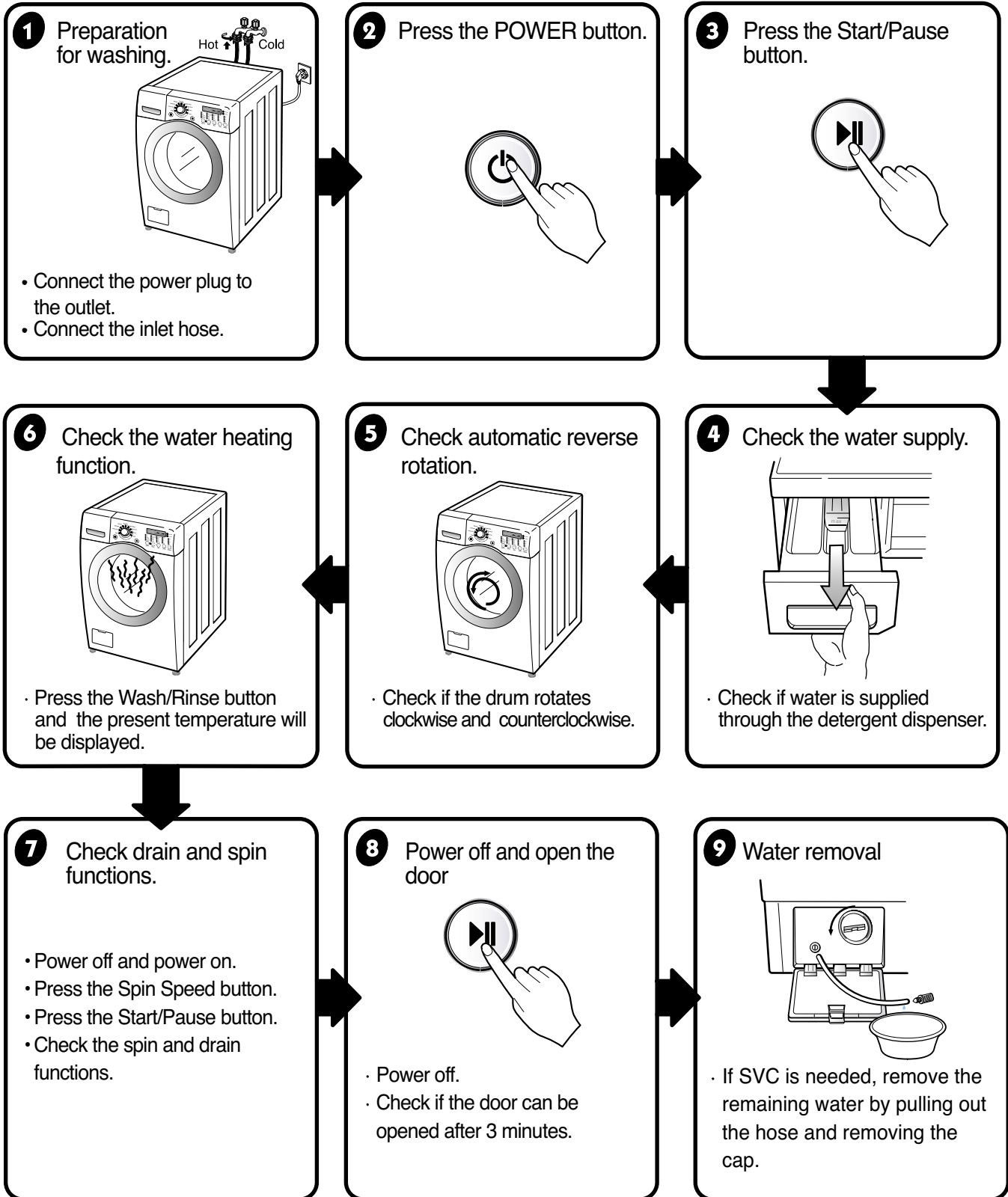

## 5. OPERATION

### • POWER button

- Use this button to turn the power On/Off.

### • EST.TIME REMAINING

- This display shows:
  - a) the estimated time remaining in the cycle when operating.
  - b) an error code when an error has been detected.

### • CHILD LOCK

- Use this option to prevent accidental changes to the settings. Press and hold Delay Start for 3 seconds to activate the child lock/unlock control.
- When Child lock is on, all controls are disabled except the power button and the washer while it is in operation.

### • CYCLE SELECTOR knob

- Rotate the **Cycle selector knob** to select the cycle designed for different types of fabric and soil levels.

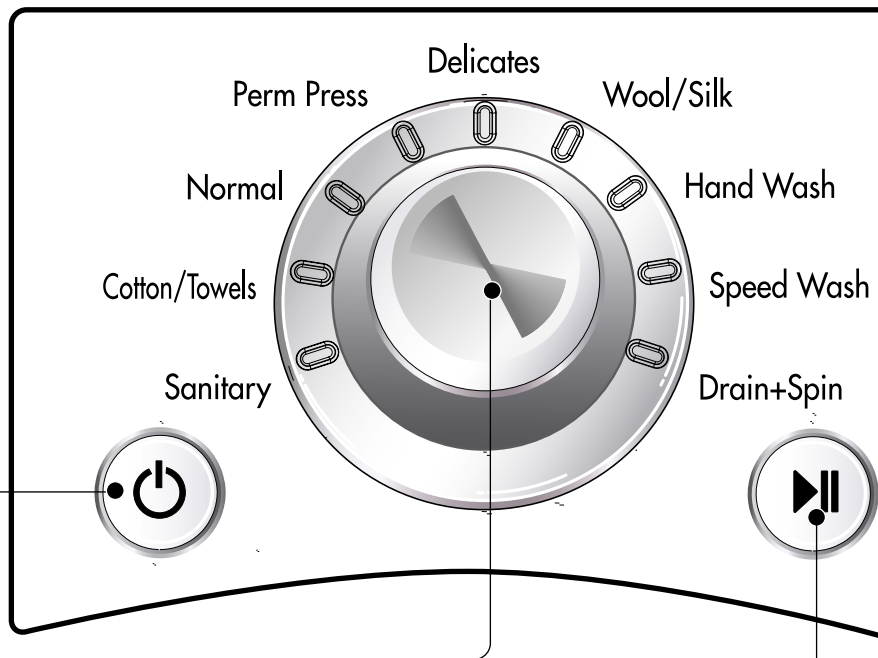

### • START/PAUSE button

- Use this button to Start/Stop the washer.

### • OPTION button

- **Soak:** Use this option to wash normal clothes or thick and heavy clothes which are excessively dirty.
- **Extra Wash:** If the laundry is heavily soiled, this option is effective.
- **Rinse+Spin:** Use this option to rinse and then spin.
- **Spin Only:** Use this option to select spin cycle only.
- **Dry Only:** When you want Dry only, select this option.

## LOCK

to prevent unwanted use of the washer. Press the Delay Wash button for 3 seconds to lock the washer.

When the Child Lock is set, Child Lock lights and all buttons except the Power button will be lit. You can lock the washer when it is operating.

## • STATUS INDICATOR

- These lights show which portion of the cycle the washer is operating.

## • Delay Wash

- Allows the start of any cycle to be delayed for 1~19 hours.

## • Extra Rinse

- This option provides an additional rinse cycle.
- Use this option to ensure the removal of detergent or bleach residue from garments.

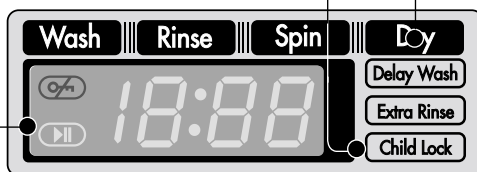

- |                                  |                                      |                                  |                              |                                 |
|----------------------------------|--------------------------------------|----------------------------------|------------------------------|---------------------------------|
| <input type="radio"/> Soak       | <input type="radio"/> Extra Hot/Cold | <input type="radio"/> Extra High | <input type="radio"/> Heavy  | <input type="radio"/> Time      |
| <input type="radio"/> Extra Wash | <input type="radio"/> Hot/Cold       | <input type="radio"/> High       | <input type="radio"/> ▼      | <input type="radio"/> More      |
| <input type="radio"/> Rinse+Spin | <input type="radio"/> Warm/Warm      | <input type="radio"/> Medium     | <input type="radio"/> Normal | <input type="radio"/> Normal    |
| <input type="radio"/> Spin Only  | <input type="radio"/> Warm/Cold      | <input type="radio"/> Low        | <input type="radio"/> ▼      | <input type="radio"/> Less      |
| <input type="radio"/> Dry Only   | <input type="radio"/> Cold/Cold      | <input type="radio"/> No Spin    | <input type="radio"/> Light  | <input type="radio"/> Low Temp. |

Delay Wash  
Press & Hold 3 sec  
To set child lock

Extra Rinse



Option



Wash/  
Rinse



Spin  
Speed



Soil  
Level



Dry

## • Wash/Rinse, Spin Speed, Soil Level Button

- Select a water temperature based on the type of load you are washing.
- To change the spin speed, press the Spin Speed button repeatedly to cycle through available options.
- To change the soil level, press the Soil Level button repeatedly until the desired setting is on.

## • DRY Button

- Dry programs selected by pressing the Dry button.
- By pressing the button [Normal – More – Time – Off – Low Temp. – Less] can be selected.



# PROGRAM CHART

\* Water Supply: W-S

\* Intermittent Spin: I-S

\* Disentangle: D-T

CYCLE COURSE	Wash										Rinse									Spin		A U T O O F F		** Approx. Working Time (Minutes)								
	Soak		Main				Normal				Extra or Stain			Extra & Stain			Spin		E N D													
	W-S	Wash	W-S	Heat	Wash	W-S	Rinse	Drain	Drain	I-S	W-S	Rinse	Drain	I-S	W-S	Rinse	Drain	I-S	W-S	Rinse	Drain	Spin	D-T		E N D	O F F						
Time (SEC)	1	2	5	6	7	8	9	10	11	12	13	14	15	16	17	18	19	20	21	22	23	24	25	26	27	28	29	20	20			
Sanitary	60	*	60	60	*	60	60	60	60	60	360	60	240	60	360	60	240	60	300	60	240	60	300	60	240	60	360	~ 60	~ 180	20	20	105
Cotton /Towels	60																															58
Normal	60																															57
Perm Press	60																															55
Delicates																																34
Wool /Silk																																34
Hand Wash																																34
Speed Wash																																30
Drain+Spin																																12
Wash + Rinse + Spin																																45
Wash + Rinse + Spin																																29

Basic Cycle  
 Optional Cycle  
 Pre-Setting Time : Water Supply - 60 sec.  
 Drain - 60 sec.

\* Wash time is in minutes.  
 \*\* The total working time will vary with the load size, water temperature and ambient temperature.



# 7. TROUBLE SHOOTING

## 7-1. BEFORE PERFORMING SERVICE

- Be careful of electric shock when disconnecting parts while troubleshooting.
- The voltage of each terminal is 110/120 V AC and DC when the unit is plugged in.

## 7-2. QC TEST MODE.

The washer must be empty and the controls must be in the off state.

1. Press the Wash/Rinse and Spin Speed buttons simultaneously.
2. Press the Power  button, while the above condition. Then buzzer will sound twice.
3. Press the Start/Pause  button repeatedly to cycle through the test modes.

Number of times the Start/Pause button is pressed	Check Point	Display Status
None	Turns on all lamps and locks the door.	
1 time	Tumble clockwise.	rpm (40~50)
2 times	Low speed Spin.	rpm
3 times	High speed Spin.	rpm
4 times	Inlet valve for bleach turns on.	Water level frequency (25~65)
5 times	Inlet valve for main wash turns on.	Water level frequency (25~65)
6 times	Inlet valve for hot water turns on.	Water level frequency (25~65)
7 times	Inlet valve for dry turns on.	Water level frequency (25~65)
8 times	Tumble counterclockwise.	rpm (40~50)
9 times	Heater turns on for 3 sec.	Water temperature
10 times	Drain pump turns on.	Water level frequency (25~65)
11 times	Dry operation for 6 minutes.	Temperature in Dry duct.
12 times	Power off and unlock the door.	Turn off all lamps.

## 7-3. HOW TO CHECK THE WATER LEVEL FREQUENCY

- \* Press the Wash/Rinse and Spin Speed button simultaneously.

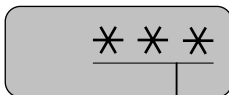











● The digits indicate the water level frequency ( x.1 kHz ).

So, for example a display indicating 241: a Water level frequency of 241 x.1 kHz  
= 24.1 kHz

## 7-4. ERROR DISPLAY





- If you press the Start/Pause button when an error is displayed, any error except 『PE』 will disappear and the machine will go into the pause status.
- In case of 『PE』, 『LE』, 『DE』 if the error is not resolved within 20 sec., or in the case of other errors, if the error is not resolved within 4 min., power will be turned off automatically and the error code will blink. In the case of 『FE』, power will not be turned off.



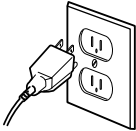
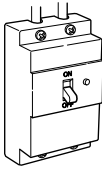

	ERROR	SYMPTOM	CAUSE
1	WATER INLET ERROR		<ul style="list-style-type: none"> <li>• Correct water level (246) is not reached within 8 minutes after water is supplied or it does not reach the preset water level within 25 minutes.</li> </ul>
2	IMBALANCE ERROR		<ul style="list-style-type: none"> <li>• The load is too small.</li> <li>• The appliance is tilted.</li> <li>• Laundry is gathered to one side.</li> <li>• Non distributable items are put into the drum.</li> </ul>
3	DRAIN ERROR		<ul style="list-style-type: none"> <li>• Not fully drained within 10 minutes.</li> </ul>
4	OVER FLOW ERROR		<ul style="list-style-type: none"> <li>• Water is overflowing (water level frequency is over 213).</li> <li>※ If  is displayed, the drain pump will operate to drain the water automatically.</li> </ul>
5	PRESSURE SENSOR ERROR		<ul style="list-style-type: none"> <li>• The SENSOR SWITCH ASSEMBLY is out of order.</li> </ul>
6	DOOR OPEN ERROR		<ul style="list-style-type: none"> <li>• Door not all the way closed.</li> <li>• Loose electrical connections at Door switch and PWB Assembly.</li> <li>• The DOOR SWITCH ASSEMBLY is out of order.</li> </ul>
7	HEATING ERROR		<ul style="list-style-type: none"> <li>• The THERMISTOR is out order.</li> </ul>

	<b>ERROR</b>	<b>SYMPTOM</b>	<b>CAUSE</b>
<b>8</b>	CURRENT ERROR		<ul style="list-style-type: none"> <li>• MAIN PWB ASSEMBLY is out of order               <ul style="list-style-type: none"> <li>☞ Replace the MAIN PWB ASSEMBLY</li> </ul> </li> <li>• Winding in the STATOR ASSEMBLY is short-circuited.               <ul style="list-style-type: none"> <li>☞ Replace the STATOR ASSEMBLY</li> </ul> </li> <li>• “CE ” is displayed during a high spin               <ul style="list-style-type: none"> <li>☞ Replace the LEAD WIRE ASSEMBLY (MOTOR)</li> </ul> </li> </ul>
<b>9</b>	MOTOR ERROR		<ul style="list-style-type: none"> <li>• The connector in the LEAD WIRE ASSEMBLY is not connected to the connector of STATOR ASSEMBLY               <ul style="list-style-type: none"> <li>☞ Reconnect or repair the connector</li> </ul> </li> <li>• The hall sensor is out of order/defective.               <ul style="list-style-type: none"> <li>☞ Replace the STATOR ASSEMBLY</li> </ul> </li> </ul>
<b>10</b>	DRY HEATOR ERROR		<ul style="list-style-type: none"> <li>• The Dry Heater is out of order               <ul style="list-style-type: none"> <li>☞ Replace the Dry Heater</li> </ul> </li> <li>• The Connector of the Dry Heater is not connected properly to the connector in the Main PWB ASSEMBLY               <ul style="list-style-type: none"> <li>☞ Reconnect or repair the connector</li> </ul> </li> <li>• The Dry fan motor is out of order               <ul style="list-style-type: none"> <li>☞ Replace the fan Motor.</li> </ul> </li> </ul>

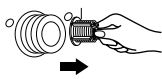
# 8. ERROR DIAGNOSIS AND CHECKLIST

## 8-1. DIAGNOSIS AND SOLUTION FOR ABNORMAL OPERATION

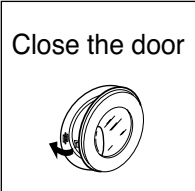
SYMPTOM	GUIDE FOR SERVICE CALL	
<p>NO POWER</p>	<p>Is the power plug connected firmly to 120V~ outlet?</p> <p style="text-align: center;">↓ YES ↓</p> <p>Power failure? or Breaker opened?</p> <p style="text-align: center;">↓ NO ↓</p> <p style="text-align: center;">Visit to check</p>	 
<p>Water inlet trouble</p> 	<p>Is " IE " displayed?</p> <p style="text-align: center;">↓ YES ↓</p> <p>Is the tap opened?</p> <p style="text-align: center;">↓ YES ↓</p> <p>Is the tap frozen?</p> <p style="text-align: center;">↓ NO ↓</p> <p>Is the water supply shut-off?</p> <p style="text-align: center;">↓ NO ↓</p> <p>Is filter in the inlet valve clogged with foreign material?</p> <p style="text-align: center;">↓ NO ↓</p> <p style="text-align: center;">Visit to check</p>	   <p style="text-align: center;">Clean the filter of inlet valve</p> 

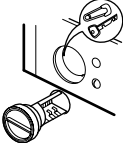
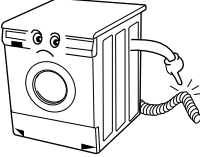
SYMPTOM	GUIDE FOR SERVICE CALL
<ul style="list-style-type: none"> <li>• Door does not open</li> <li>• Error displayed on the program</li> </ul> 	<p>Started with door opened? <b>YES</b> </p> <p><b>NO</b></p> <p>Close the door </p> <p>Visit to check</p> <p>&lt;Check if the door switch is O.K.&gt;</p>
<ul style="list-style-type: none"> <li>• DRAIN TROUBLE</li> </ul> 	<p>Is "OE" displayed?</p> <p><b>YES</b></p> <p>Is the drain pump filter clogged with foreign material such as pin, coin and etc.? <b>YES</b> Clean up the filter. </p> <p><b>NO</b></p> <p>Is the drain hose frozen with water, kinked or crushed?</p> <p><b>NO</b></p> <p>Visit to check </p>

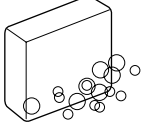
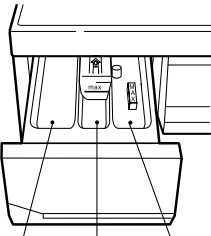
SYMPTOM	GUIDE FOR SERVICE CALL
<p>◦ Suds overflow from the appliance. (In this condition, wash and spin do not operate normally)</p>	<div style="display: flex; justify-content: space-between;"> <div style="width: 65%;"> <p>Is low-sudsing detergent for the drum washing machine used?</p> <p style="text-align: center;"><b>YES</b></p> <p>Is the proper amount of detergent used as recommended?</p> <p style="text-align: center;"><b>YES</b></p> <p style="text-align: center;">Reduce the amount of detergent.</p> <p>* This appliance has the automatic suds sensing function which operates during high-sudsing for good rinse and preventing overflow. * When high suds are sensed, suds removing function such as drain, water input and pause will operate without rotating the drum.</p> </div> <div style="width: 30%; text-align: center;">  <p><b>LOW-SUDSING</b></p> </div> </div>
<p>• Liquid laundry products do not flow in.</p>	<div style="display: flex; justify-content: space-between;"> <div style="width: 65%;"> <p>Is softener put in the correct compartment of the drawer?</p> <p style="text-align: center;"><b>YES</b></p> <p>Is the drawer closed during wash?</p> <p style="text-align: center;"><b>YES</b></p> <p>Is the cap clogged?</p> <p style="text-align: center;"><b>YES</b></p> <p style="text-align: center;">Explain proper use of liquid laundry products. <b>&lt; Clean the compartment for softener &gt;</b></p> </div> <div style="width: 30%; text-align: center;">  <p>Detergent for wash    Fabric softener    Liquid Bleach</p> </div> </div>
<div style="display: flex; flex-direction: column; align-items: center;"> <div style="display: flex; gap: 10px;"> <div style="border: 1px solid gray; padding: 2px 5px;">FE</div> <div style="border: 1px solid gray; padding: 2px 5px;">dHE</div> </div> <div style="display: flex; gap: 10px; margin-top: 5px;"> <div style="border: 1px solid gray; padding: 2px 5px;">FE</div> <div style="border: 1px solid gray; padding: 2px 5px;">CE</div> </div> <div style="display: flex; gap: 10px; margin-top: 5px;"> <div style="border: 1px solid gray; padding: 2px 5px;">EE</div> <div style="border: 1px solid gray; padding: 2px 5px;">LE</div> </div> </div>	<p style="text-align: center; border: 1px solid gray; border-radius: 15px; padding: 10px;">Visit to check</p>

## 8-2. FAULT DIAGNOSIS AND TROUBLESHOOTING

### ⚠ CAUTION

1. Be careful of electric shock or disconnecting the parts while trouble shooting.
2. First of all, check the connection of each part terminal with wiring diagram.
3. If you replace the MAIN PWB ASSEMBLY, put in the connectors correctly.

### NO POWER

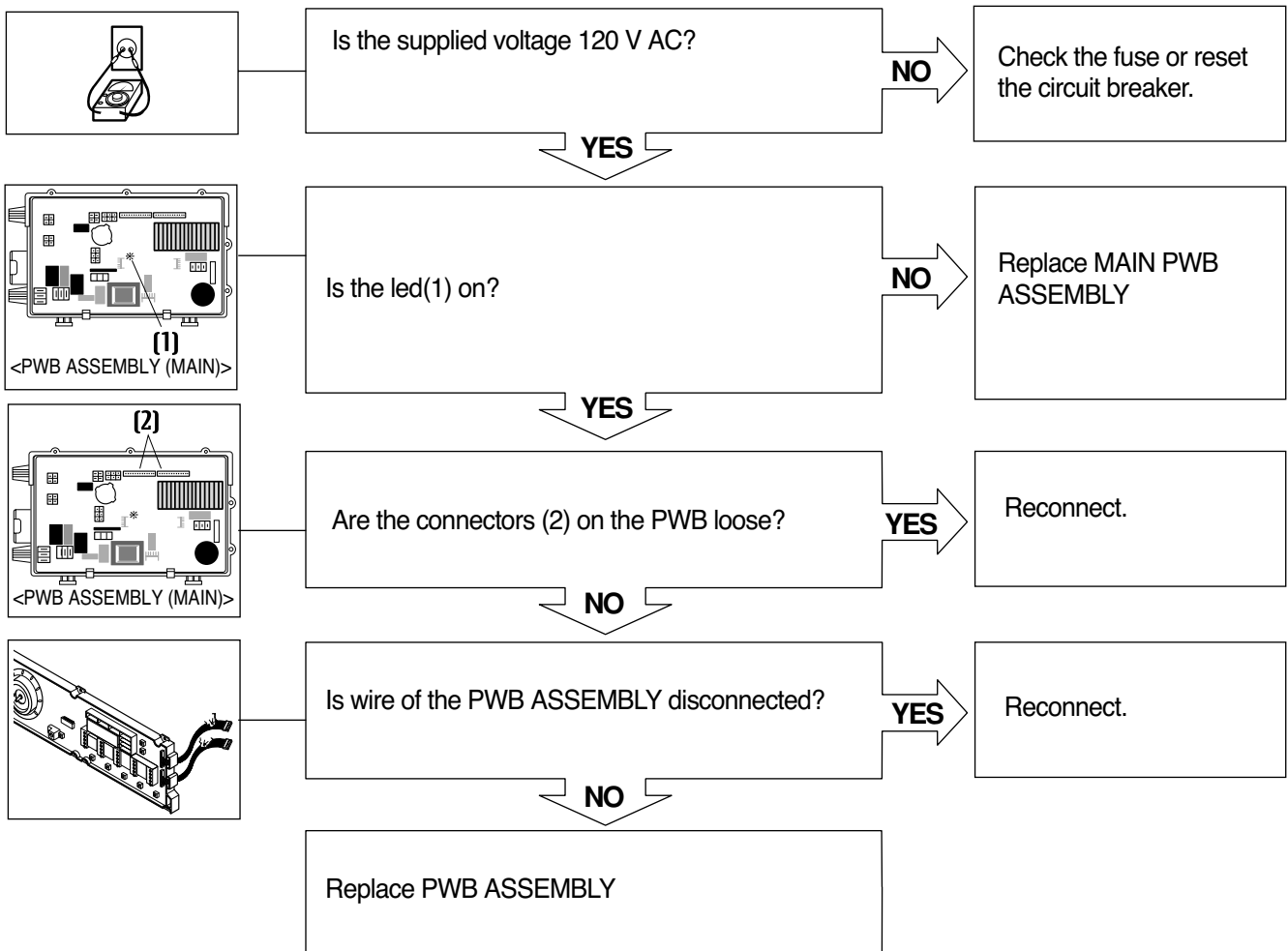

## NO WATER SUPPLY

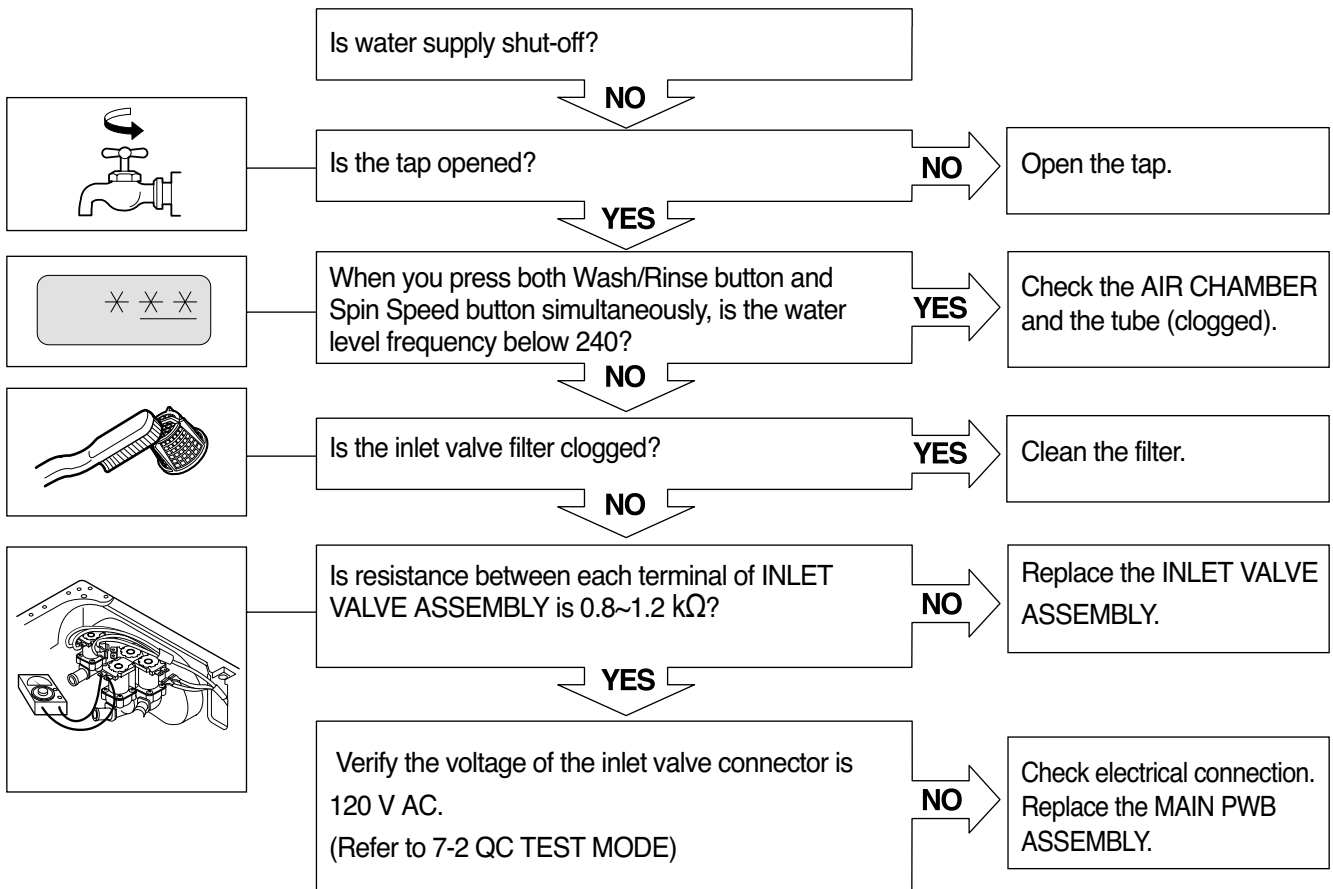

## DETERGENT DOES NOT FLOW IN

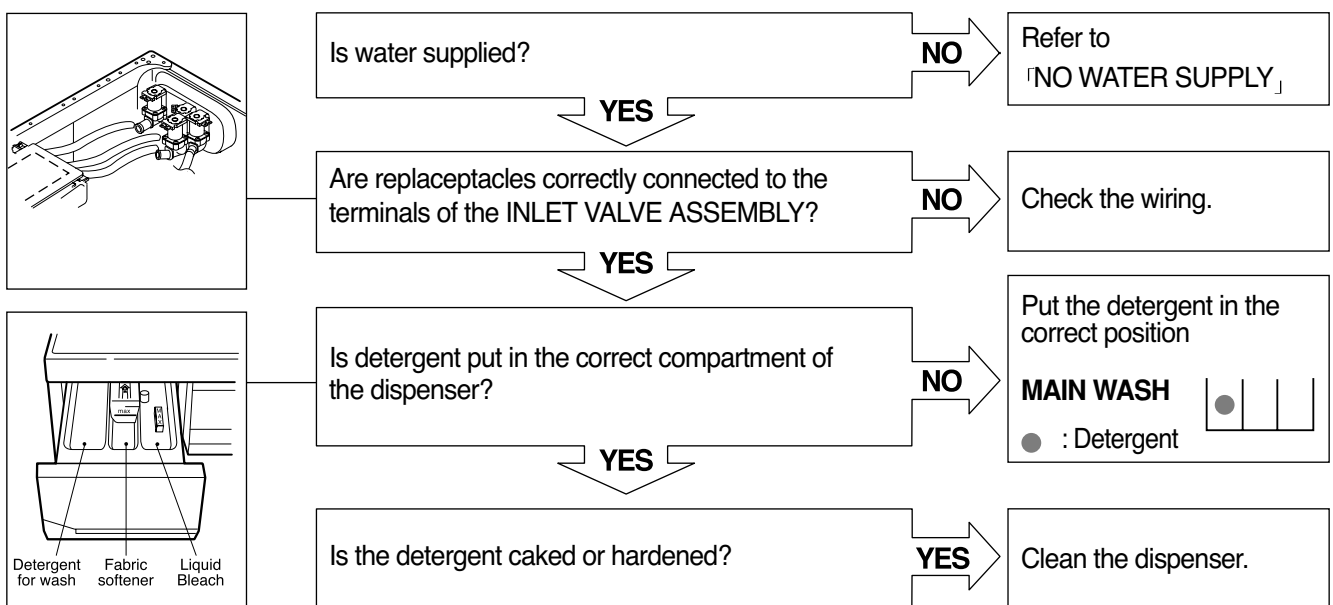

## SOFTENER/BLEACH DOES NOT FLOW IN

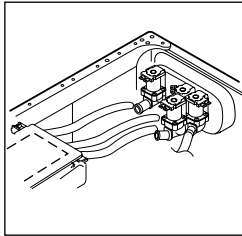

Is water supplied?

**NO**

Refer to  
「NO WATER SUPPLY」

**YES**

Are receptacles correctly connected to the terminals  
of the INLET VALVE ASSEMBLY?

**NO**

Check the wiring.

**YES**

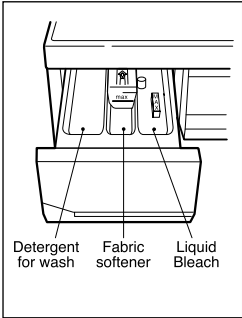

Is softener/bleach put in the correct compartment of  
the dispenser?

**NO**

Put it in the correct  
compartment.

**YES**

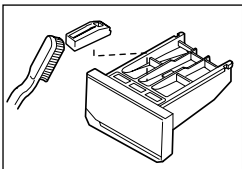

Is the softener/bleach cap clogged?

**YES**

Clean the cap and  
container.

## ABNORMAL SOUND

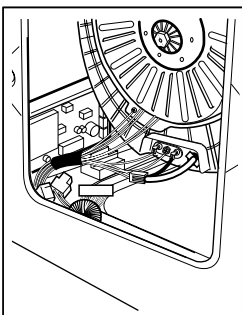

Is the motor bolt loosened?

**YES**

Secure the bolt.

**NO**

Is there friction noise coming from the motor?

**YES**

Replace the STATOR  
ASSEMBLY or ROTOR  
ASSEMBLY.

## HEATING WITHOUT WATER

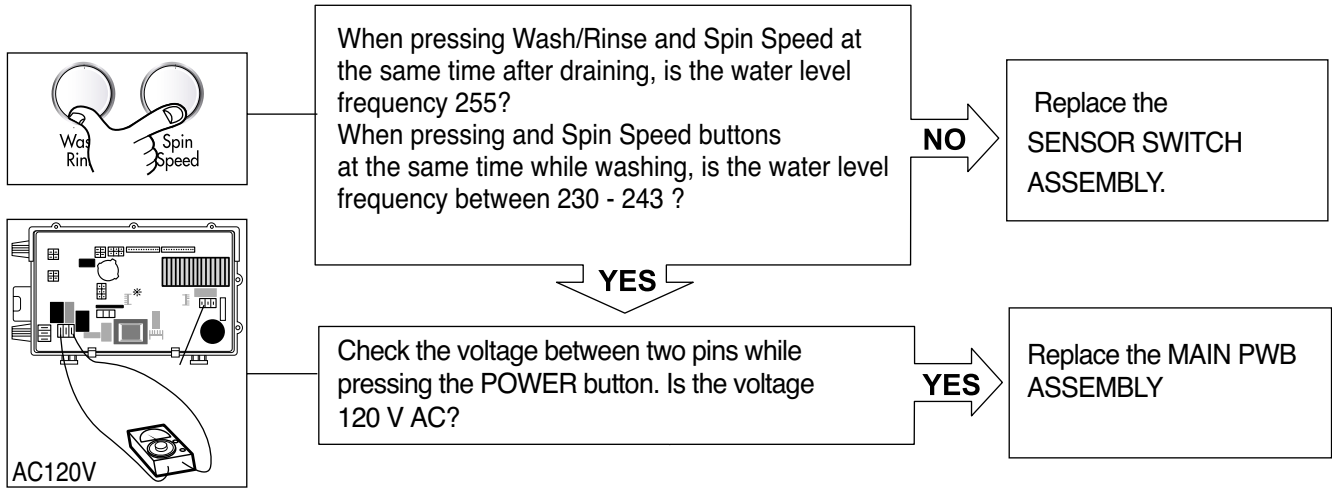

## DRAIN MALFUNCTIONING

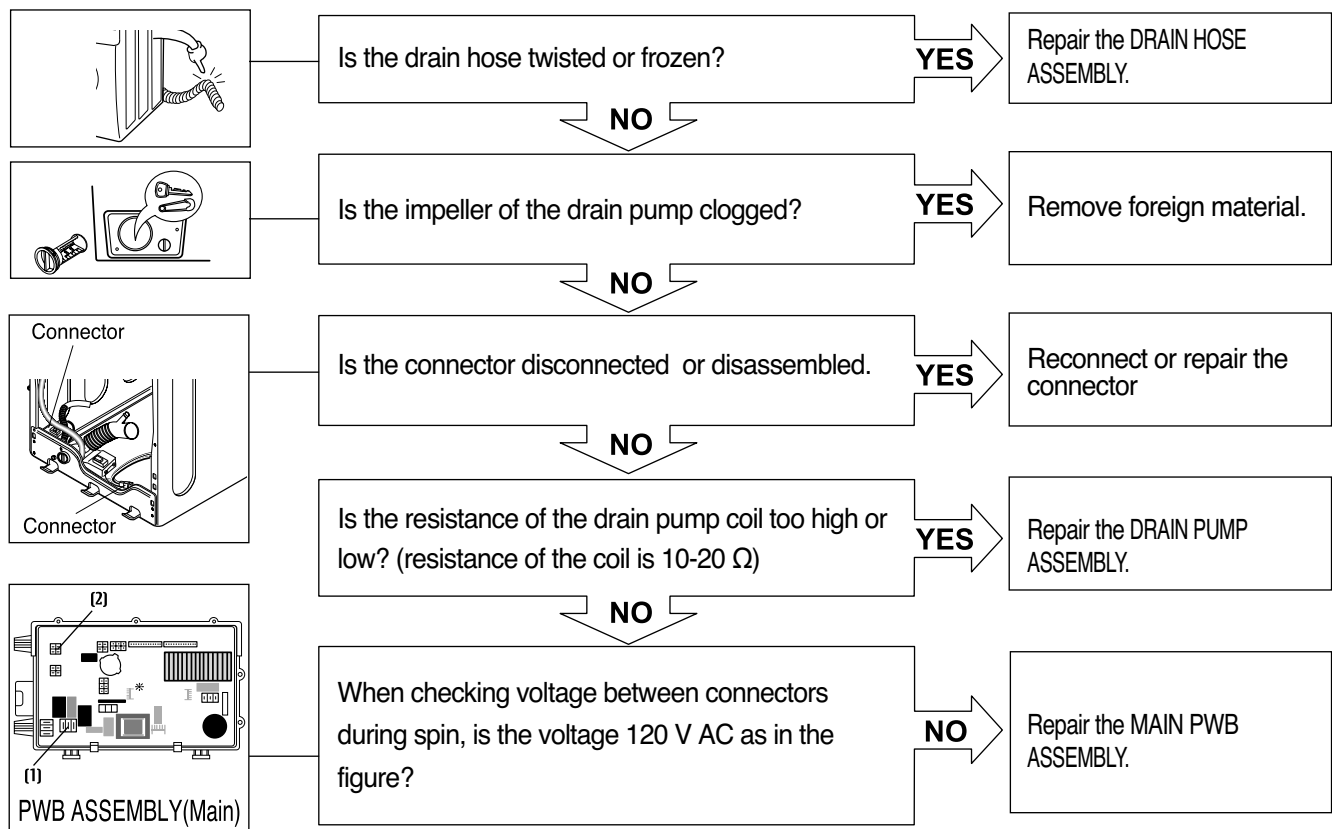

## WASH HEATER TROUBLE

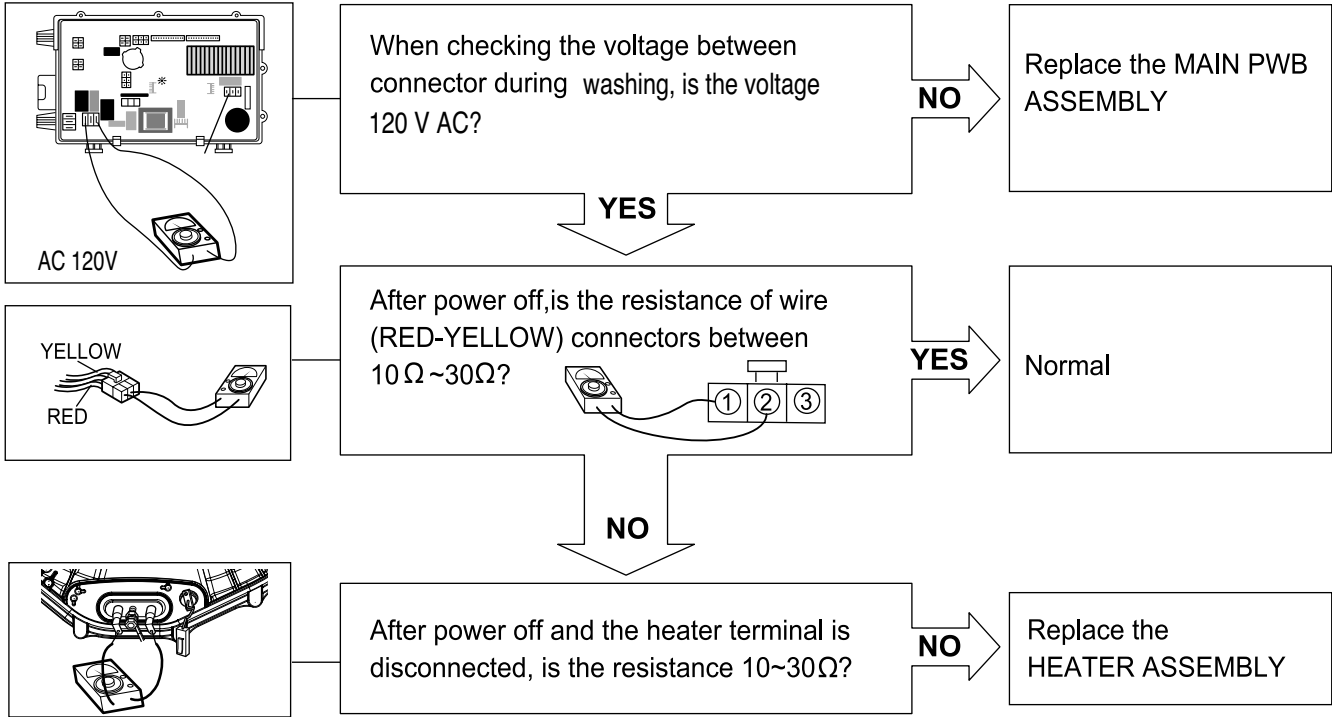

## HEATING CONTINUOUSLY ABOVE THE SETTING WATER TEMPERATURE

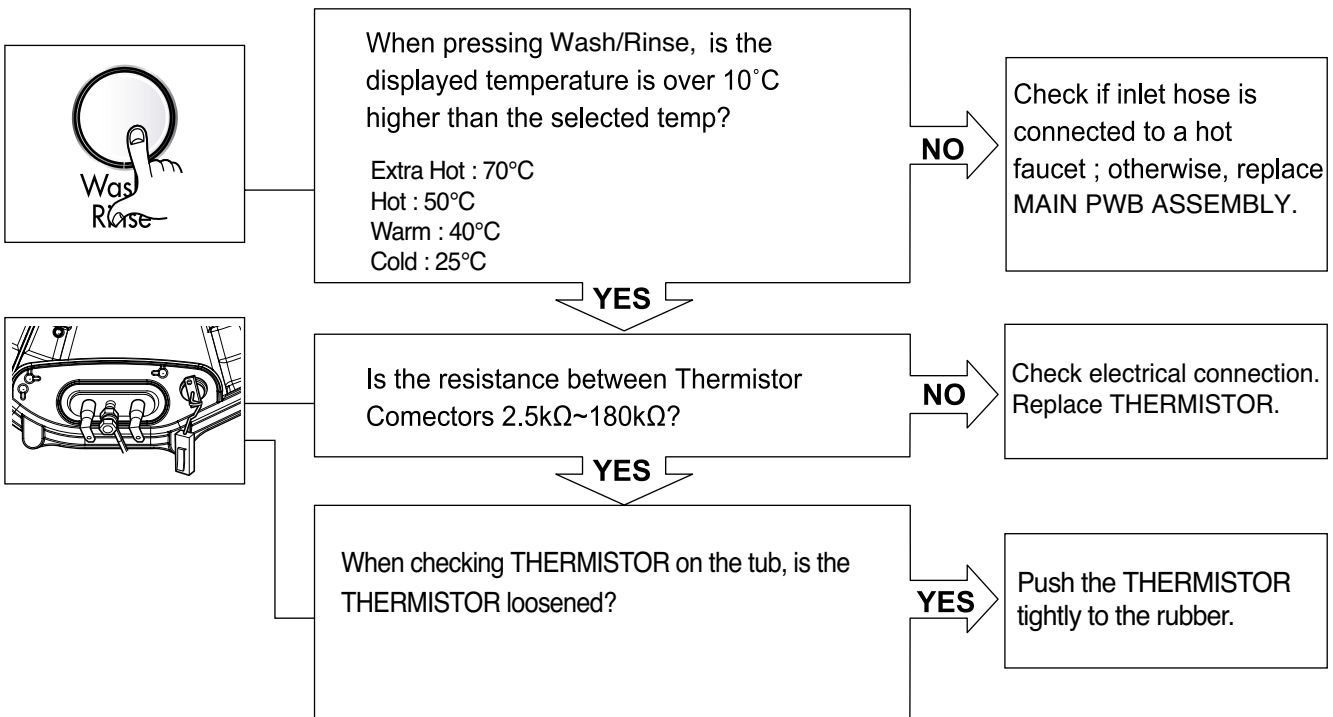

## SPIN TROUBLE

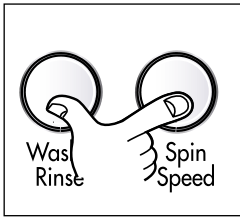

Check during spin if the frequency of the water level is 248 or more.

**NO**

Check the SENSOR SWITCH ASSEMBLY or HOSE (Pressure). If the problem is on the SENSOR SWITCH ASSEMBLY or the HOSE, replace the SENSOR SWITCH ASSEMBLY or the HOSE.

**YES**

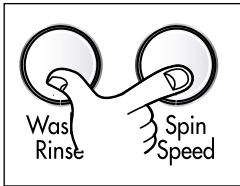

Press the Start/Pause button 2 times in QC Test mode, is the drum spinning at low speed?

**YES**

Normal

**NO**

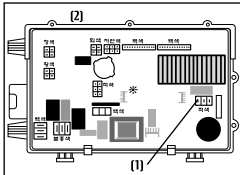

Is it disconnected, or disassembled?  
[Red:3pin(1), GY:4pin(2)]

**YES**

Reconnect or repair connector

**NO**

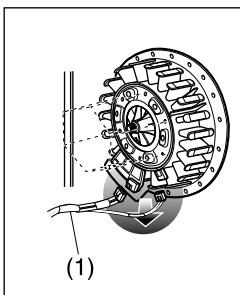

Check the motor connector, is the resistance of the terminal same as the figure?

**MOTOR TERMINAL (1)**



Resistance of terminal:

①~② / ②~③ / ③~① : About 5 Ω~15 Ω

**NO**

Replace the STATOR ASSEMBLY

**YES**

Replace the MAIN PWB ASSEMBLY

## ERROR

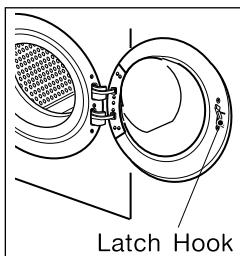

Does the spring of Latch Hook actuate?

**NO**

Replace Door Assembly.

**YES**

Is DOOR SWITCH ASSEMBLY broken?

**NO**

Check the DOOR SWITCH ASSEMBLY Connector and MAIN PWB ASSEMBLY [Red 3 pin and blue 4 pin white 3 pin connector (1) connector (1)].

**YES**

Replace the DOOR SWITCH ASSEMBLY.

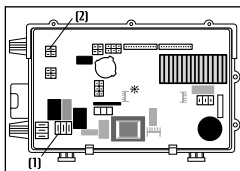

## [dHE] ERROR DISPLAY

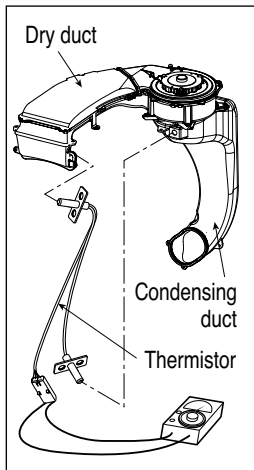

Is the resistance of 1 thermistor on dry duct  $2.5\text{k}\Omega \sim 180\text{k}\Omega$  (at  $105^\circ\text{C} \sim 0^\circ\text{C}$ )

**NO**

Replace the thermistor.

**YES**

### CHECK FOR DRY HEATER TROUBLE

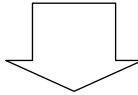

### CHECK FOR DRY FAN MOTOR TROUBLE

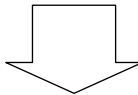

Disassemble the cabinet cover and condensing bellows.  
Is there any foreign object in condensing bellows.

**YES**

Clean the bellows

**NO**

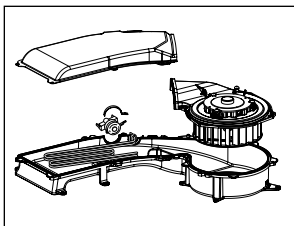

Disassemble the dry fan assy and dry duct upper, and clean foreign object in duct and fan.

## DRY HEATER TROUBLE

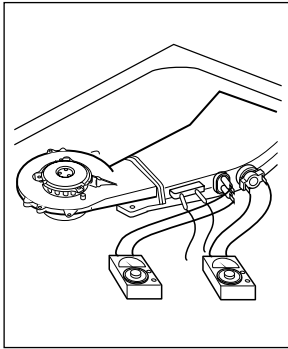

After power off, is the resistance of dry heater 10 ~ 40Ω?

**NO**

Replace the dry heater.

**YES**

Is thermostat closed?

**NO**

Replace the thermostat.

**YES**

When checking voltage between connectors of the dry heater on drying, is the voltage AC 120V ?

**NO**

Replace the PWB ASSEMBLY(Main)

## DRY FAN MOTOR TROUBLE

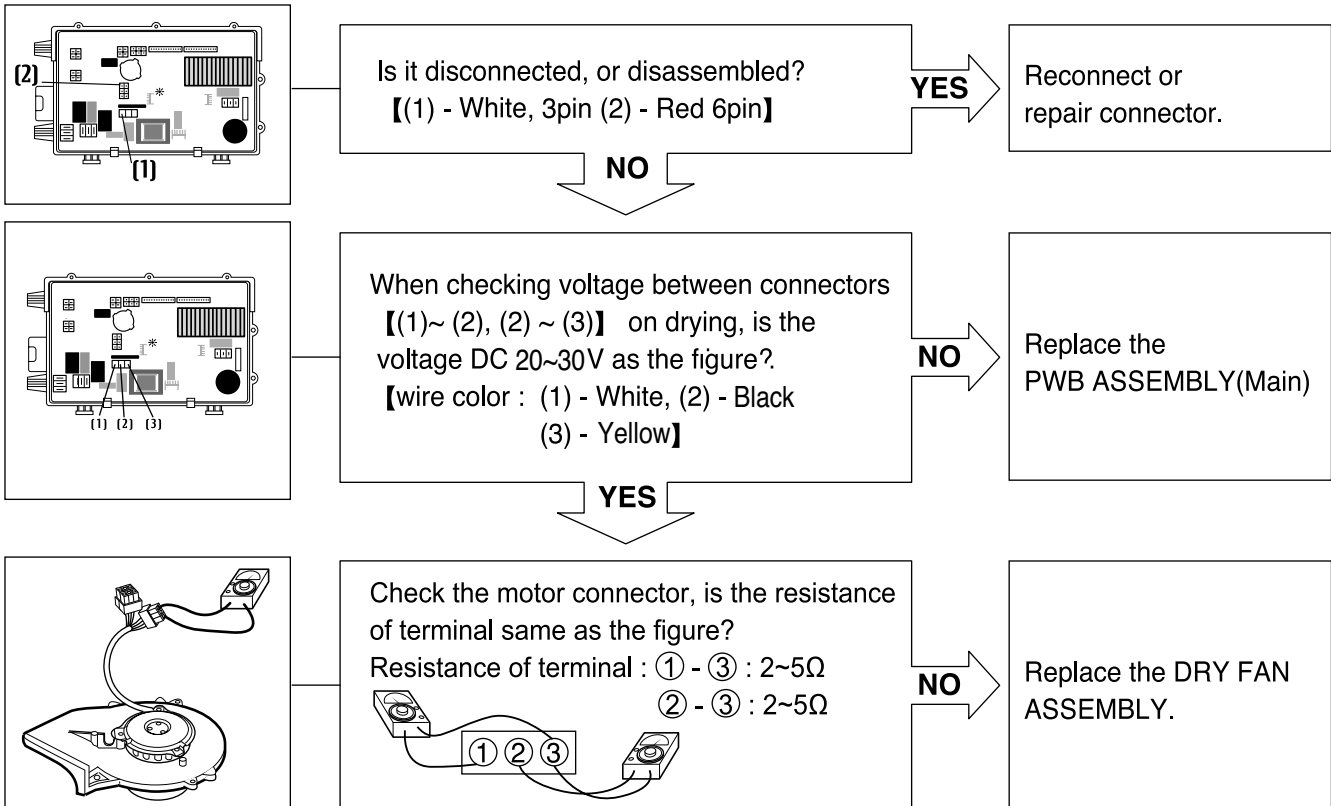

**LOT OF VAPOR IN DRAWER WHEN DRYING**

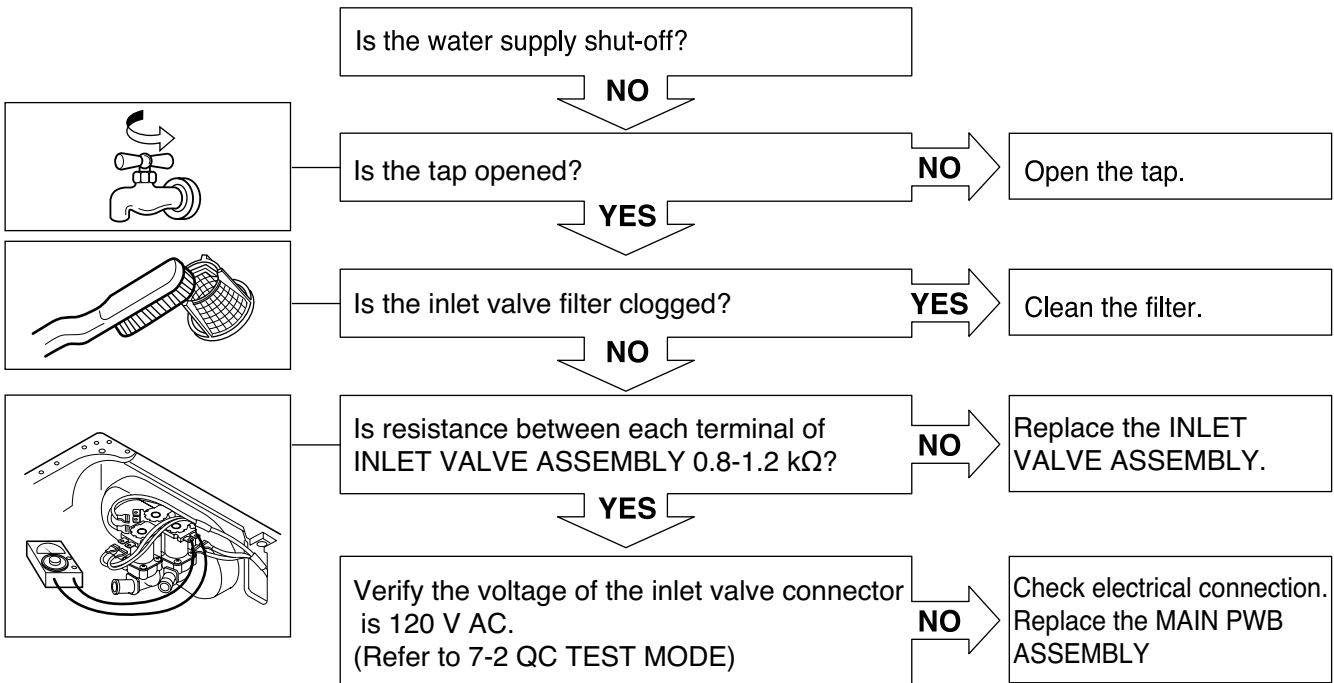

# 9. DISASSEMBLY INSTRUCTIONS

\* Be sure to unplug the machine from the outlet before disassembling and repairing the parts.

## CONTROL PANEL

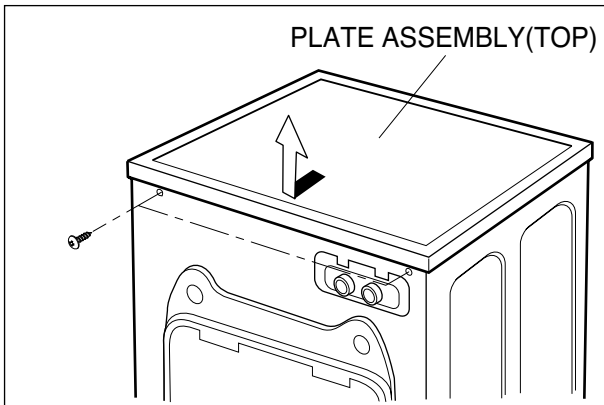

- ① Unscrew 2 screws on the back of the top plate.
- ② Pull the top plate backward and upward as shown.

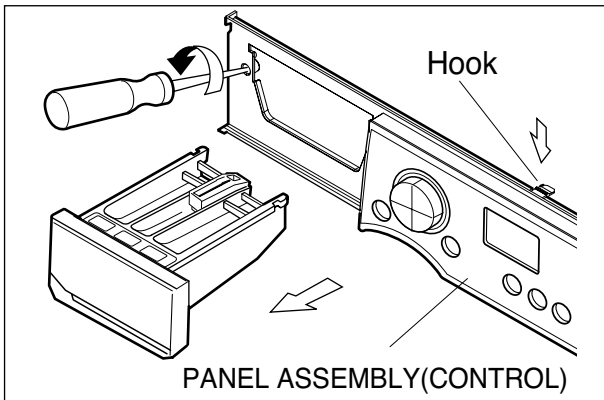

- ③ Disconnect the Display PWB Assembly connector from Flat cable.
- ④ Pull out the drawer and unscrew 2 screws.
- ⑤ Push 2 upper hooks and pull the Control Panel Assembly forward.

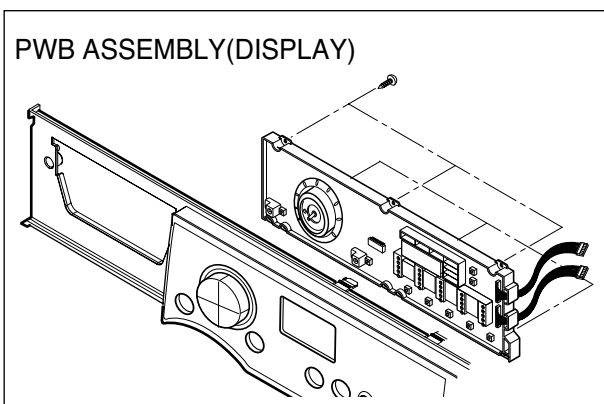

- ⑥ Unscrew the 6 screws from the Control Panel Assembly.
- ⑦ Disassemble the Display PWB Assembly.

## PWB ASSEMBLY(MAIN)

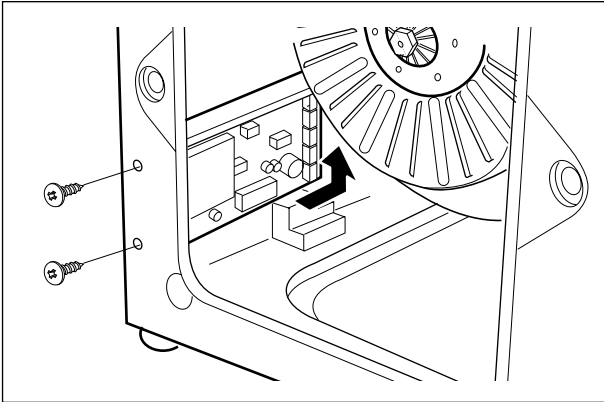

- ① Unscrew the 4 screws from the back cover.
- ② Unscrew the 2 screws from the lower-left side of the cabinet.
- ③ Disconnect the connectors.
- ④ Disassemble the Main PWB Assembly in arrow direction.

## DISPENSER ASSEMBLY

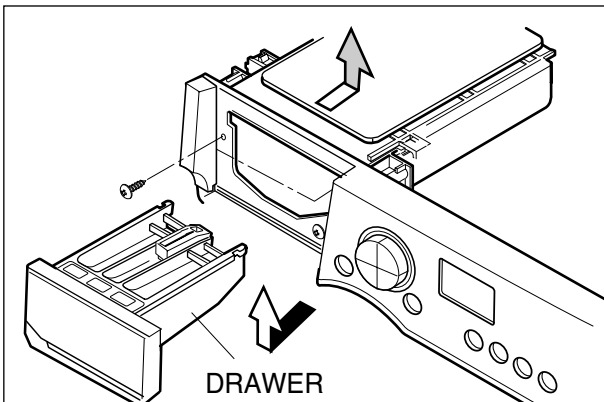

- ① Disassemble the Top plate assembly.
- ② Pull out the drawer.
- ③ Unscrew the 2 screws and push out the dispenser assembly.

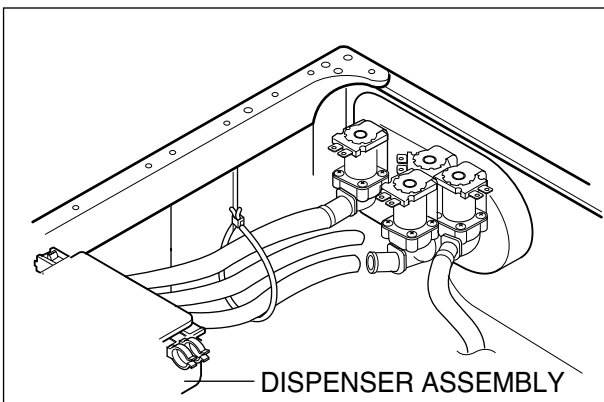

- ④ Disassemble the clamps and hoses.
- ⑤ Disassemble the bellows at the lower side of the dispenser.

## INLET VALVE

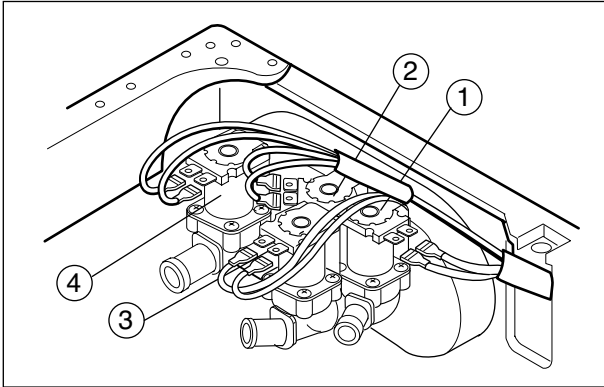

- ① Disassemble the 4 connectors from the valves.
- ② Unscrew the 2 screws from the back of the cabinet.

\* Wire color

VALVE ① (DRY)	YL - BK
VALVE ② (BLEACH)	GY - BK
VALVE ③ (MAIN WASH)	WH/ - BK
VALVE ④ (HOT)	BL - BK

## DOOR

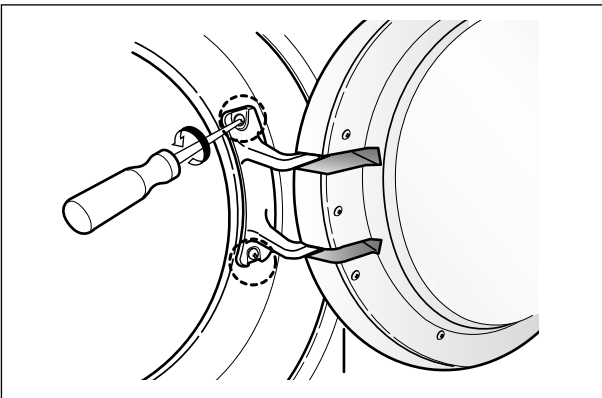

- ① Open the door.
- ② Unscrew the 2 screws from the Cabinet Cover.
- ③ Disassemble the door upward.

※ When removing the Door Assembly, it is necessary to hold the Bracket that is inside of the Cabinet Cover.

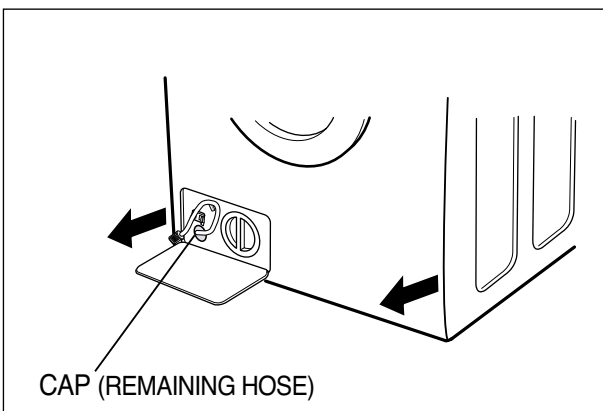

### Method of removing remaining water

Drain in to bucket by pulling out hose and removing cap.

## GASKET ASSEMBLY

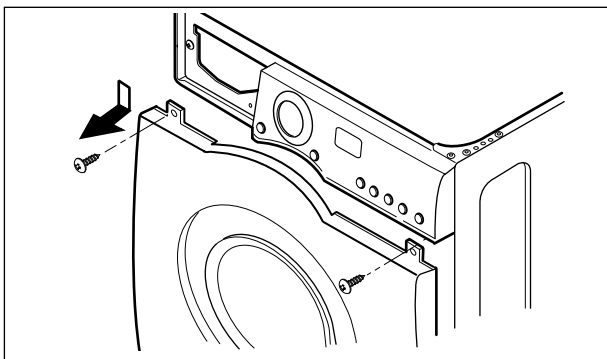
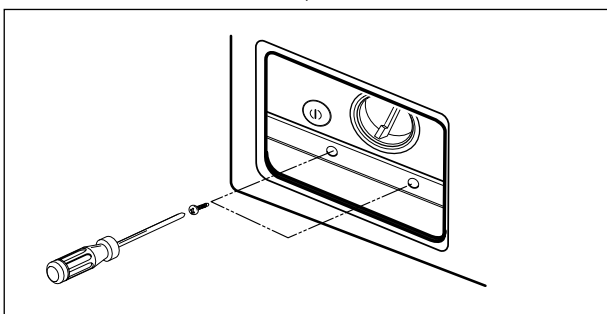
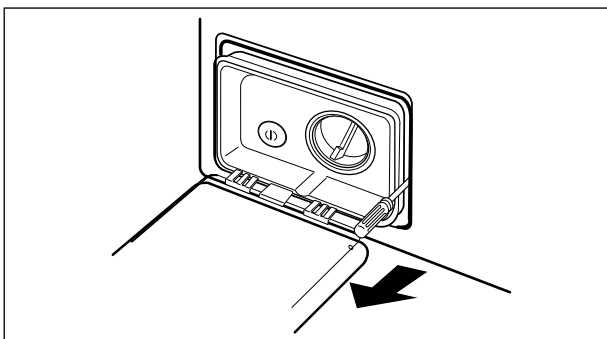
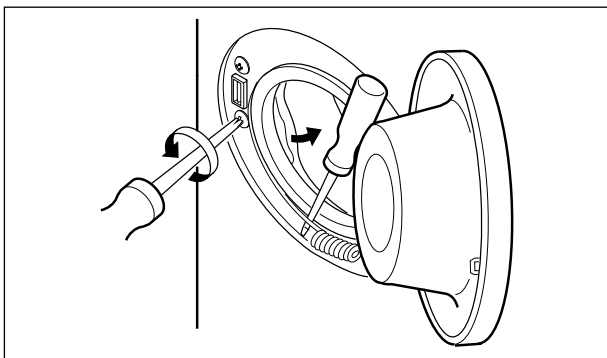

- ① Disassemble the clamp assembly.
- ② Unscrew the 2 screws from cabinet cover.

- ③ Unscrew the screw from filter cover.
- ④ Put a flat ( - ) screwdriver or putty knife into the both sides of the filter cover, and pull it out.

- ⑤ Unscrew the 2 screws from the lower side of the cabinet cover.

- ⑥ Unscrew the 2 screws from upper part of the cabinet cover.

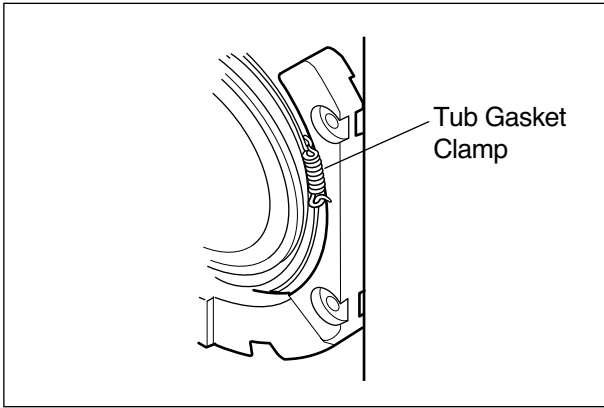
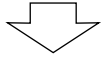

⑦ Disassemble the clamp assembly.

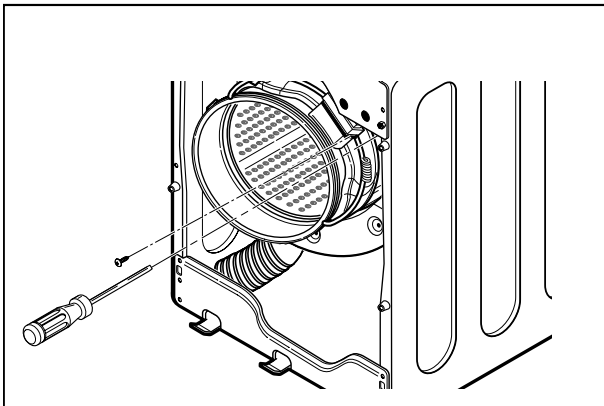
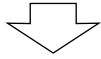

⑧ Remove dry gasket clamp by loosening the screw.

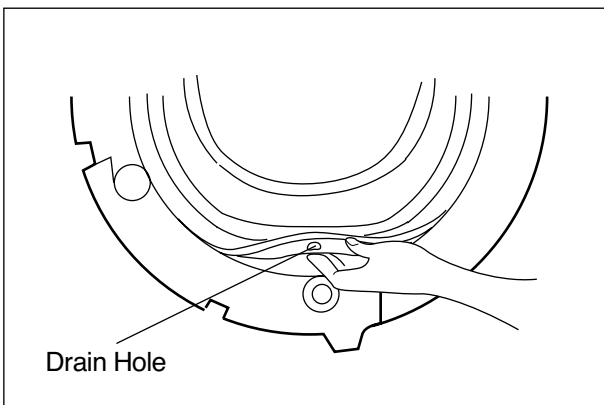
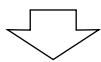

⑨ When reassembling the gasket, put the drain hole of the gasket downward.

## ROTOR ASSEMBLY, STATOR ASSEMBLY, FRICTION DAMPER

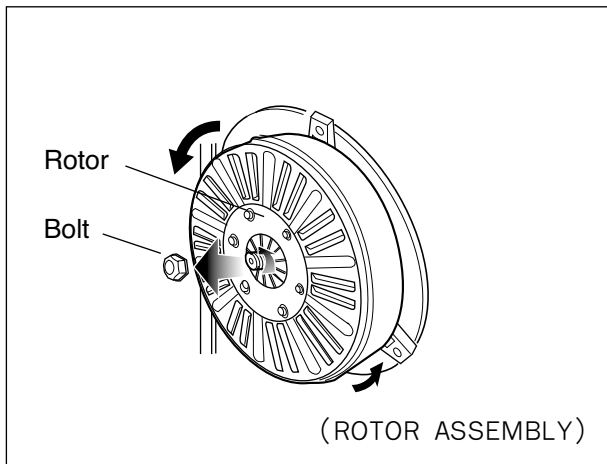

- ① Disassemble the back cover.
- ② Remove the bolt.
- ③ Pull out the Rotor.

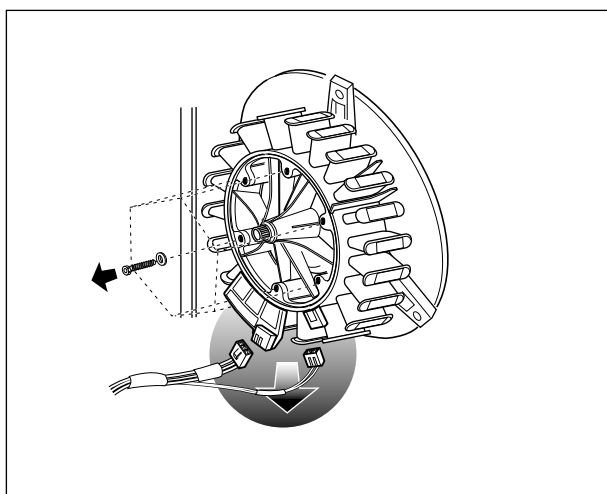

- ③ Unscrew the 2 screws from the tub bracket.
- ④ Remove the 6 bolts on the stator.
- ⑤ Unplug the 2 connectors from the stator.

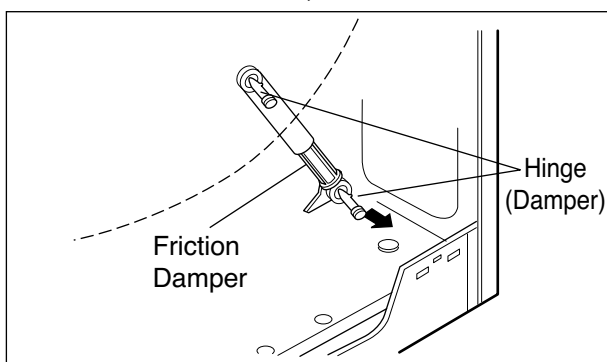

- ⑥ Disassemble the damper hinges from the tub and base.
- ⑦ Separate the dampers.

### ※ NOTE

Once removed, replace the damper pin with new one.

## PUMP

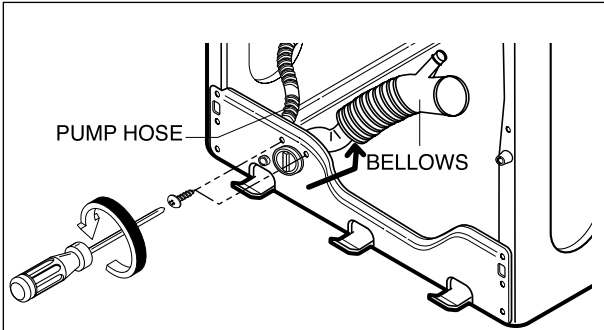

- ① Disassemble the cabinet cover.
- ② Separate the pump hose and the bellows from the pump assembly.
- ③ Disassemble the pump assembly in arrow direction.

## HEATER

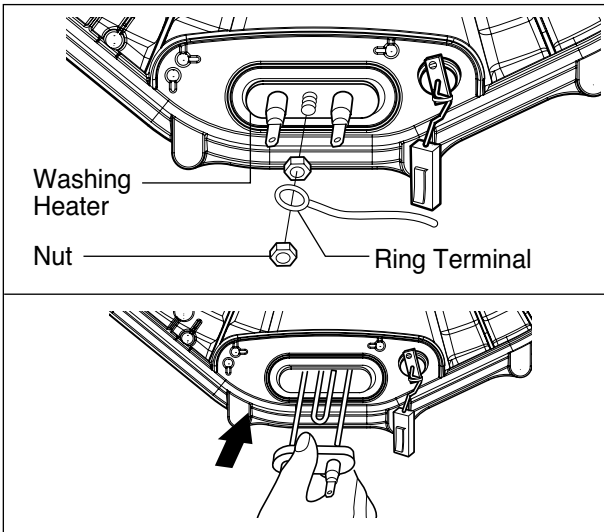

- ① Disassemble the back cover.
- ② Separate 2 connectors from the heater.
- ③ Loosen the nut and pull out the heater.

### ⚠ CAUTION

- When assembling the heater, insert the heater into the heater clip on the bottom of the tub.
- Tighten the fastening nut so the heater is secure.

## THERMISTOR

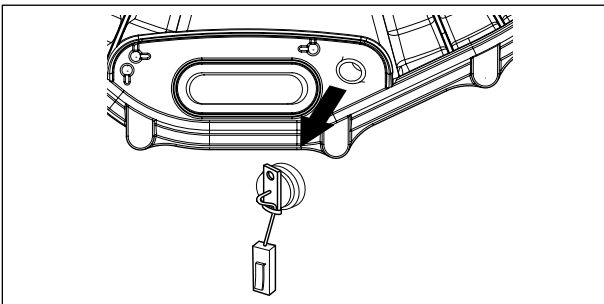

- ① Disassemble the back cover.
- ② Unplug the white connector from the thermistor.
- ③ Pull it out by holding the bracket of the thermistor.

## SWITCH ASSEMBLY, DOOR LOCK

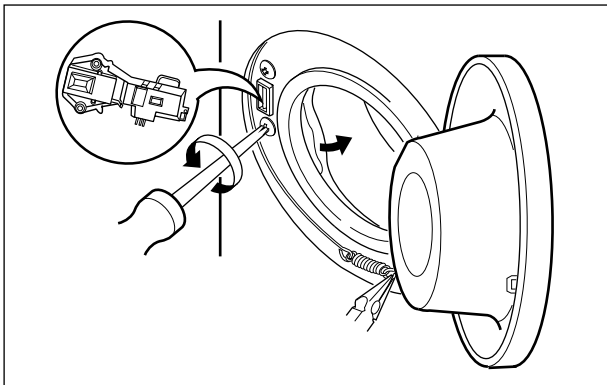

- ① Open the door and disassemble the Clamp assembly.
- ② Unscrew the 2 screws.
- ③ Disconnect the connector from the Door switch assembly.

### ※ NOTE

Reconnect the connector after replacing the DOOR SWITCH ASSEMBLY.

## WHEN A FOREIGN OBJECT IS STUCK BETWEEN DRUM AND TUB

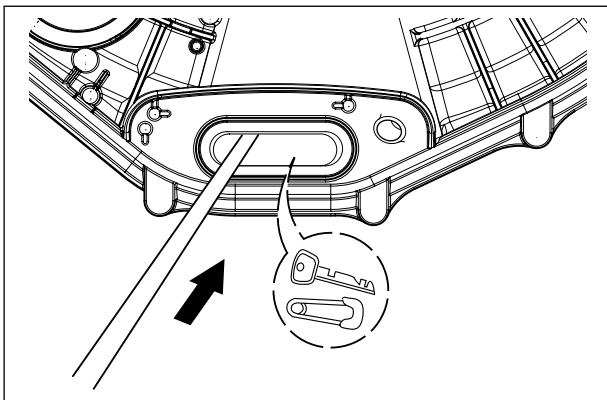

- ① Disassemble the back cover.
- ② Separate the heater from the tub.
- ③ Remove any foreign objects (wire, coin, etc.) by inserting a long bar in the opening.

## DRY DUCT

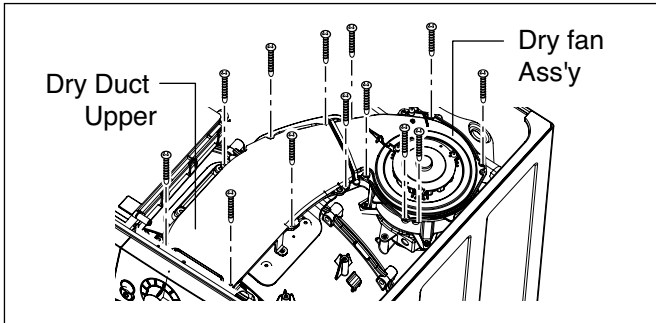

- ① Remove 6 screws and dry fan assembly.
- ② Remove 7 screws and dry duct upper.

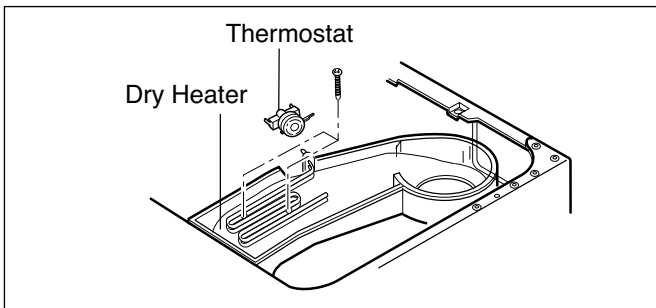

- ① Remove 2 screws and dry heater.
- ② Remove thermostat.

## CONDENSING DUCT

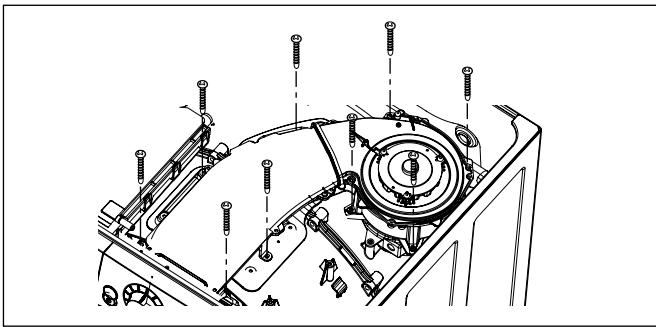

- ① Remove 17 screws from Dry duct upper and Dry fan Assembly.

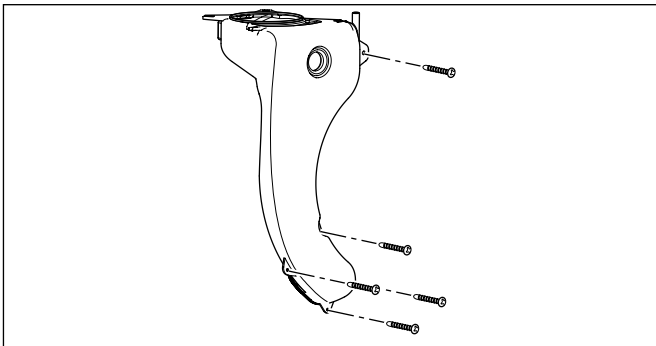

- ① Remove 5 screws and condensing duct.

# 10. EXPLODED VIEW AND PART LIST

## 10-1. CABINET & CABINET COVER ASSEMBLY

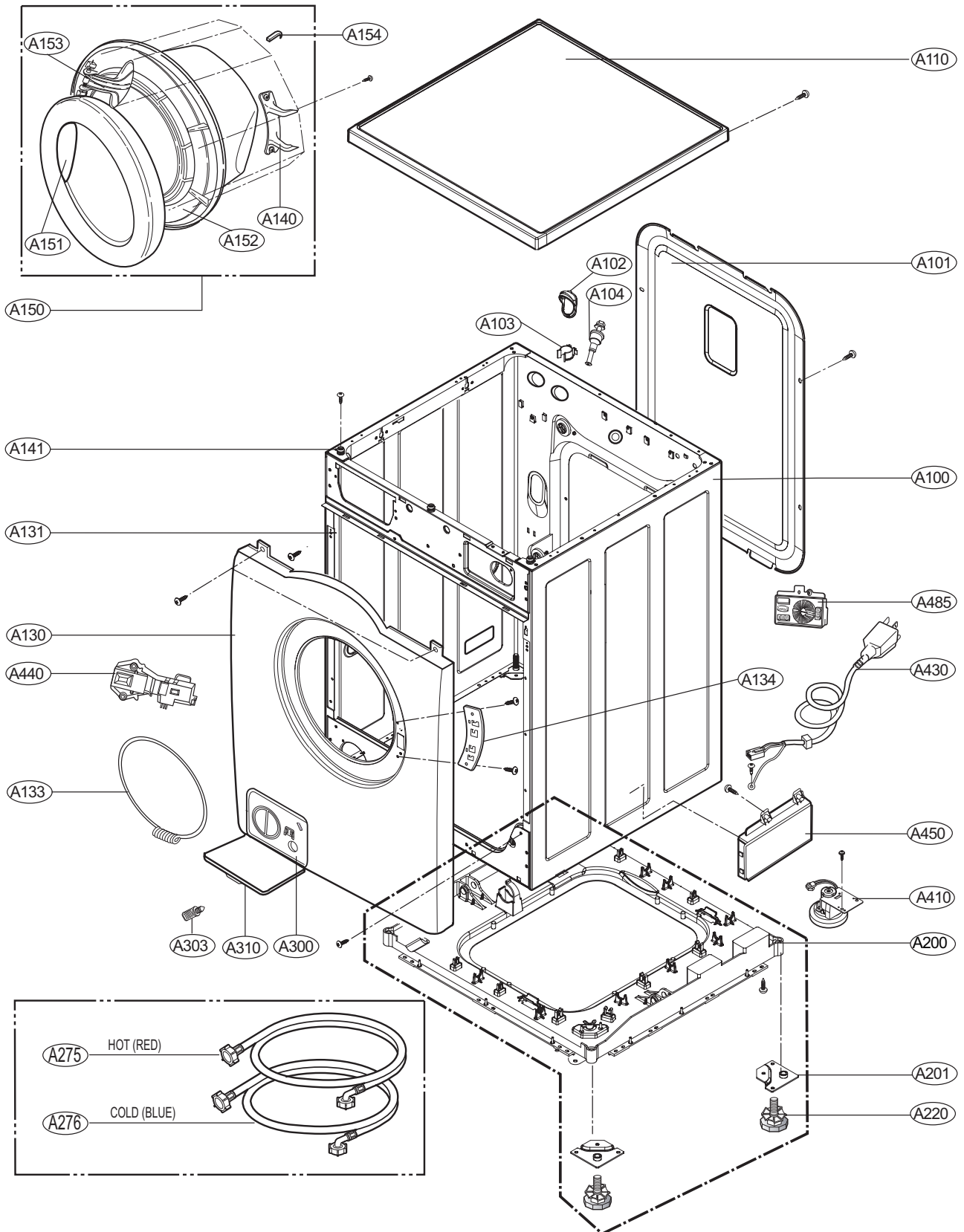

## 10-2. CONTROL PANEL & DISPENSER ASSEMBLY

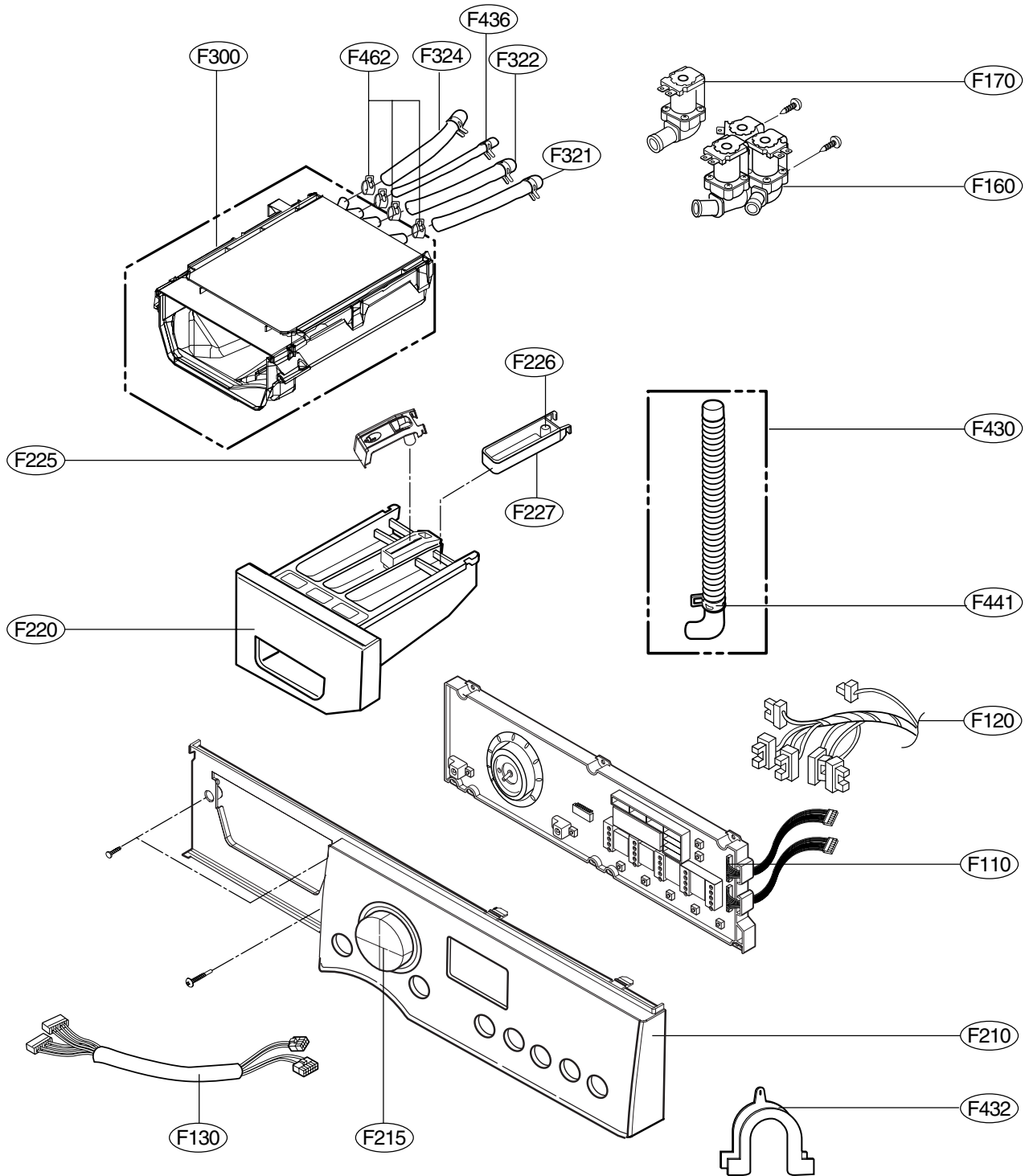



# 10-4. DRYER

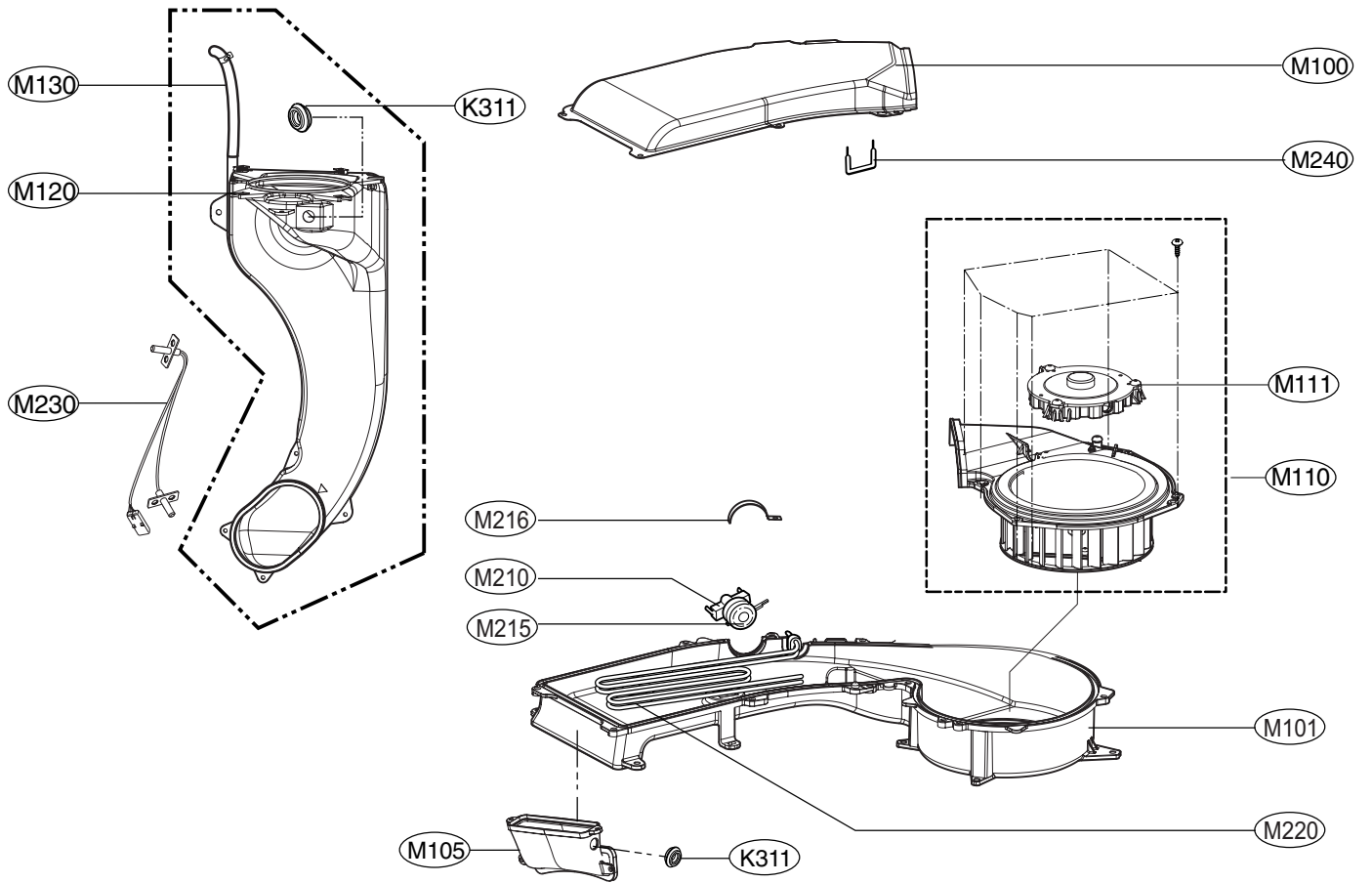

REPLACEMENT PARTS LIST

CAUTION : Before replacing any part of these components  
Read carefully the safety precautions in this manual

■ NOTE : S(Safety Parts), AL(Alternative parts)

LG MODEL: WD-14311RD.AOWEEUS		Run_Date : 2005-01-24				
YOUR MODEL: WM3431HW		SPECIFICATION: 120V 60Hz				
S	AL	LOC	DESCRIPTION	PARTS No.	QTY	REMARKS
		*001	MANUAL ASSEMBLY,OWNERS	3829ER3031H	1	
		*002	BOX,CARTON	3890EZ3446K	1	
		*003	SPANNER	3W20018B	1	
		*004	MANUAL,SERVICE	3828ER3035Q	0	
		A100	CABINET ASSEMBLY	3091ER0006P	1	
		A101	COVER,BACK	3808FR1202A	1	
		A102	BUSHING	4830FR3107A	1	
		A103	HOLDER	4930FR3151A	1	
		A104	BOLT ASSEMBLY	4011FR3159G	4	
		A110	TOP PLATE ASSEMBLY	3457ER1005A	1	
		A130	COVER,CABINET	3550ER1018A	1	
		A133	CLAMP ASSEMBLY	2W20017C	1	
		A140	HINGE	4774ER2006A	1	
		A141	HOLDER	4930ER4001A	3	
		A150	DOOR ASSEMBLY	3581ER1007B	1	
		A151	DOOR FRAME,OUTER	3212ER1015A	1	
		A152	DOOR FRAME,INNER	3212ER1014A	1	
		A153	HANDLE	3650ER2003A	1	
		A200	BASE,CABINET	3040FR0049A	1	
		A201	BRACKET,BASE	4810ER3016A	4	
		A220	LEG ASSEMBLY	4779ER3002A	4	
		A275	HOSE,INLET	5215FD3715G	1	
		A276	HOSE,INLET	5215FD3715H	1	
		A300	CASE	3110ER3002A	1	
		A303	CAP,DRAIN HOSE	5006ER3009A	1	
		A310	CAP,COVER	5006ER3012A	1	
△		A410	SWITCH ASSEMBLY,SENSOR SWITCH	6600FA1704S	1	
△		A430	POWER CORD ASSEMBLY	6411ER1006E	1	
△		A440	SWITCH ASSEMBLY,DOOR	6601ER1005B	1	
△		A450	PWB(PCB) ASSEMBLY,MAIN	6871EC1126F	1	
△		A485	FILTER ASSEMBLY(CIRC)	6201EC1006A	1	
△		F110	PWB(PCB) ASSEMBLY,DISPLAY	6871EC2034A	1	
△		F120	HARNESS,PWB	6877ER1030L	1	
△		F130	CABLE,FLAT	6877EC2001C	1	
△		F140	HARNESS,MOTOR	6877ER1007F	1	
		F160	VALVE ASSEMBLY,INLET	5220FR2075C	1	
		F170	VALVE ASSEMBLY,INLET	5220FR2006H	1	
△		F210	PANEL ASSEMBLY,CONTROL	3721ER1080N	1	
		F215	KNOB,ROTARY	4940ER3015B	1	
		F220	PANEL ASSEMBLY,DRAWER	3721ER1066W	1	
		F300	DISPENSER ASSEMBLY	4925ER1017B	1	
		F310	BELLOWS	4738ER2004A	1	
		F321	HOSE,INLET	5214FR4125D	1	
		F322	HOSE,INLET	5214FR4125L	2	
		F325	HOSE,INLET	5214ER4003A	1	
		F440	HOSE,PUMP	5214FR3188G	1	
		F441	CLAMP	4861FR3068C	1	
		F461	CLAMP	4861FR3068C	1	
		K100	TUB ASSEMBLY,DRUM	3045ER0029D	1	
		K105	TUB ASSEMBLY,OUTER[SUB5]	3045ER0030A	1	
		K110	TUB ASSEMBLY,INNER[DRUM]	3045ER1010C	1	
		K115	SPIDER	4434ER1005A	1	
		K121	BEARING,BALL	4280FR4048M	1	
		K122	BEARING,BALL	4280FR4048G	1	

**LG MODEL: WD-14311RD.AOWEEUS**

**Run\_Date : 2005-01-24**

**YOUR MODEL: WM3431HW**

**SPECIFICATION: 120V 60Hz**

S	AL	LOC	DESCRIPTION	PARTS No.	Q'TY	REMARKS
		K123	BOLT ASSEMBLY	4040FR4051C	1	
		K125	SEAL	4036ER2003A	1	
		K140	COVER,TUB	3550ER0028A	1	
		K141	SEAL	4036ER4001A	1	
		K143	SCREW,DRAWING	1SZZFA4362C	13	
		K146	COVER,PROTECT	3550ER3011A	1	
		K310	THERMISTOR ASSEMBLY	6322FR2046C	1	
		K320	HEATER ASSEMBLY	5301FR1158K	1	
		K340	MOTOR ASSEMBLY,PUMP	4681EA2001D	1	
		K344	CASING ASSEMBLY,PUMP	3661FR2093E	1	
		K346	FILTER(MECH)	5230ER3001A	1	
		K350	STATOR ASSEMBLY	4417FA1994E	1	
		K360	ROTOR ASSEMBLY	4413ER1001B	1	
		K411	HOLDER	4930FR3040A	2	
		K420	SPRING,HINGE	4970FR2084T	2	
		K510	GASKET	4986ER1003A	1	
		K520	BELLOWS	4738FR1145A	1	
		K530	CLAMP ASSEMBLY	4861ER2001B	1	
		K540	CHAMBER,AIR	3504FR3134A	1	
		K550	HOSE,INLET	5214FR4125M	1	
		K610	DAMPER ASSEMBLY,FRICION	4900FR2030F	2	
		K611	HINGE	4774FR3118B	4	
		M100	DUCT,OUTLET	5208ER1006A	1	
		M101	DUCT,OUTLET	5208ER1005A	1	
		M105	DUCT,INLET	5208ER2003A	1	
		M110	MOTOR ASSEMBLY,FAN	4680ER1001G	1	
		M120	DUCT ASSEMBLY	5209ER0004B	1	
		M210	THERMOSTAT ASSEMBLY	6931FR3108A	1	
		M215	SEAL	4036FR4045A	1	
		M216	CLAMP	4860ER3004A	1	
		M220	HEATER ASSEMBLY	5301FR2076G	1	
		M230	THERMISTOR ASSEMBLY	6322FR2046K	1	
		M240	FUSE ASSEMBLY	6901ER4001A	1	