

**Whirlpool®**

# **SERVICE MANUAL**

**WHIRLPOOL 4.3 CU FT  
COMPACT HEAT PUMP DRYER**



**WHD3090GW  
WHD5090GW**

---

## FORWARD

This Whirlpool Service Manual, (Part No. W11040040), provides the In-Home Service Professional with service information for the “WHIRLPOOL 4.3 CU FT COMPACT HEAT PUMP DRYER.”

The Wiring Diagram used in this Service Manual is typical and should be used for training purposes only. Always use the Wiring Diagram supplied with the product tech sheet when servicing the washer.

For specific operating and installation information on the model being serviced, refer to the “Use and Care Guide” or “Installation Instructions” provided with the washer.

## GOALS AND OBJECTIVES

The goal of this Service Manual is to provide information that will enable the In-Home Service Professional to properly diagnose malfunctions and repair the “WHIRLPOOL COMPACT HEAT PUMP DRYER.”

The objectives of this Service Manual are to:

- Understand and follow proper safety precautions.
- Successfully troubleshoot and diagnose malfunctions.
- Successfully perform necessary repairs.
- Successfully return the washer to its proper operational status.

WHIRLPOOL CORPORATION assumes no responsibility for any repairs made on our products by anyone other than authorized In-Home Service Professionals.

---

# TABLE OF CONTENTS

## WHIRLPOOL COMPACT HEAT PUMP DRYER

### SECTION 1 — GENERAL INFORMATION

DRYER SAFETY .....	1-2
GENERAL INFORMATION .....	1-3
GENERAL THEORY OF OPERATION .....	1-4
CONTROL PANEL AND FEATURES .....	1-6
DRYER MAINTENANCE .....	1-7
MODEL & SERIAL NUMBER LOCATION .....	1-8
TECH SHEET LOCATION .....	1-8
MODEL AND SERIAL NUMBER NOMENCLATURE .....	1-9
PRODUCT SPECIFICATIONS .....	1-10

### SECTION 2 — DIAGNOSTICS & TROUBLESHOOTING

CONTROL PANEL .....	2-2
ABBREVIATIONS .....	2-3
ICONS .....	2-3
DIAGNOSTIC GUIDE .....	2-3
SERVICE DIAGNOSTIC MODE/SERVICE TEST CYCLE .....	2-3
ACTIVATING SERVICE DIAGNOSTIC MODE .....	2-3
SERVICE TEST CYCLE .....	2-4
SERVICE TEST CYCLE CHART .....	2-5
EXITING SERVICE DIAGNOSTIC MODE .....	2-6
FAULT/ERROR CODES .....	2-6
TROUBLESHOOTING GUIDE .....	2-8

### SECTION 3 — COMPONENT TESTING

COMPONENT TESTING: SAFETY INFORMATION .....	3-2
WIRING DIAGRAM .....	3-3
COMPONENT TESTING .....	3-4
TEST #1: ACU POWER CHECK .....	3-4
ACU BOARD / CONNECTORS & PINOUTS .....	3-5
TEST #2: SUPPLY CONNECTIONS (IF) .....	3-6
TEST #3: MOTOR CIRCUIT (M) .....	3-8
TEST #4: HEATING SYSTEM (COMPRESSOR) .....	3-9
TEST #4A: HEAT PUMP (HE) .....	3-9
TEST #4C: THERMISTOR (SET2) .....	3-11
TEST #5: MOISTURE SENSOR .....	3-12
TEST #5A: ADJUSTING CUSTOMER-FOCUSED DRYNESS LEVEL .....	3-13
TEST #6: BUTTONS AND INDICATORS .....	3-14
TEST #7: DOOR SWITCH (ACU) .....	3-15
TEST #8: DRAIN PUMP (DP) .....	3-16
TEST #9: WATER LEVEL SWITCH (SLE) .....	3-17
TEST #10: AUXILIARY FAN (FM) .....	3-18
TEST #11: HEATER EXCHANGE SWITCH (HX) .....	3-19
TEST #12: COMMUNICATION BETWEEN UI AND ACU (W12) .....	3-20

---

## TABLE OF CONTENTS (CONTINUED)

### SECTION 4 — COMPONENT ACCESS

PARTS & ASSEMBLIES - TOP AND CONSOLE PARTS .....	4-2
PARTS & ASSEMBLIES - CABINET PARTS .....	4-3
PARTS & ASSEMBLIES - BASE PARTS .....	4-4
PARTS & ASSEMBLIES - MOTOR PARTS .....	4-5
PARTS & ASSEMBLIES - DRUM AND BULKHEAD PARTS.....	4-6
PARTS & ASSEMBLIES - DOOR PARTS.....	4-7
REMOVING THE DOOR ASSEMBLY & DOOR COMPONENTS .....	4-8
REMOVING THE TOP & SIDE PANELS .....	4-9
REMOVING THE INTERFERENCE FILTER .....	4-10
REMOVING THE CONSOLE/USER INTERFACE .....	4-11
REMOVING THE APPLIANCE CONTROL UNIT (ACU) .....	4-12
REMOVING THE WATER TANK HOUSING .....	4-13
REMOVING THE DRIVE MOTOR .....	4-14
REMOVING THE DRAIN PUMP, FLOW SWITCH AND FAN ASSEMBLIES.....	4-15
REMOVING THE FRONT PANEL .....	4-17
REMOVING THE DRUM .....	4-18
REMOVING THE FRONT BULKHEAD.....	4-19
REMOVING THE BACK PANEL.....	4-20
REMOVING THE HEAT PUMP (BASE ASSEMBLY).....	4-21

**PRODUCT SPECIFICATIONS & WARRANTY INFORMATION SOURCES** (inside back cover)

# Section 1: General Information

This section provides general safety, parts, and information for the “Whirlpool Compact Heat Pump Dryer.”

- Dryer Safety
- Introduction
- General Theory of Operation
- Control Panel and Features
- Dryer Maintenance
- Model/Serial Number Location
- Tech Sheet Location
- Model & Serial Number Nomenclature
- Product Specifications

## Dryer Safety

### Your safety and the safety of others are very important.

We have provided many important safety messages in this manual and on your appliance. Always read and obey all safety messages.



This is the safety alert symbol.

This symbol alerts you to potential hazards that can kill or hurt you and others.

All safety messages will follow the safety alert symbol and either the word "DANGER" or "WARNING."  
These words mean:

**⚠ DANGER**

You can be killed or seriously injured if you don't immediately follow instructions.

**⚠ WARNING**

You can be killed or seriously injured if you don't follow instructions.

All safety messages will tell you what the potential hazard is, tell you how to reduce the chance of injury, and tell you what can happen if the instructions are not followed.

## General Information

### INTRODUCTION

The Whirlpool compact dryer has a 24" width and a ventless design to take the next step in energy efficiency. It recycles air and removes moisture to provide the consumer with a more efficient drying experience. It is flexible enough to install virtually anywhere and is our most space-saving dryer available. Remove wrinkles with the Wrinkle Shield™ option that intermittently tumbles clothes for up to 12 hours after the cycle ends, or dry a small load quickly with the new "X-Dry" cycle option.

### Features:

#### Space-Saving Design:

The Whirlpool compact heat pump dryer has a 24" width and a ventless design. Its slim design makes it flexible enough to install virtually anywhere and has a 4.3 cu. ft. capacity that provides room to fit your clothes while still being able to fit your space.

#### Sleek Tap Touch Controls with Memory:

Start the dryer quickly using the sleek control interface of the Tap Touch controls with Memory. This technology allows direct access to dryer functions and even remembers the consumer's last cycle and settings to save them time.



Figure 1

#### Baffles:

Care for each garment with baffles that provide balanced tumbling for gentle, perfect drying.

### Cycles:

#### Refresh Cycle:

Refresh the load using the Refresh cycle, so dry, clean clothes are ready to wear without needing to be rewashed.

#### Wool Cycle:

Keep cozy, dryable wool fabrics fluffy and smooth with the Wool cycle that uses a gentle drying process.

#### Bulky Bedding Cycle:

Wrap up in a warm, fresh-from-the-dryer comforter. Perfectly dry bedding or other bulky items with the Bulky Bedding cycle.

#### Air Dry Cycle:

Prevents heat damage to fabrics. The Air Dry cycle is great for airing, refreshing and loosening up loads without added heat.



Figure 2

### Options:

#### Wrinkle Shield™ Option:

Help prevent wrinkles with the Wrinkle Shield™ option. Intermittent tumbling helps keep wrinkles from setting into clean clothes for up to 12 hours after the cycle ends.

#### Gentle Dry Option:

Gentle drying for delicate loads with the Gentle Dry option that reduces the drying temperature.

#### X-Dry Option:

Dry a small load quickly when you're on a tight schedule with X-Dry.

# General Theory of Operation

## Heat Pump Technology

A typical dryer uses large amounts of energy; this dryer consumes a fraction of the energy by recycling and reclaiming heat. This dryer is a ventless heat pump dryer that uses a refrigeration system to dry and recycle the same air. The laundry is dried with low temperatures; therefore it may feel cooler than expected during and after the drying process.

The heat pump dryer's heating phase is longer than in traditional dryers. If possible, do not open the dryer door during the process as heat can escape from the drum and can make longer drying times.

## Benefits of a Heat Pump

- **ENERGY:** Regenerates energy to reduce overall energy consumption.
- **PERFORMANCE:** Allows flexibility to manage drying performance and energy savings.
- **FABRIC CARE:** Capability to use less heat than vented dryer.
- **VENTLESS DESIGN:** Allows installation in more locations throughout the home.

## New Sounds from a Heat Pump

- Dryer runs on a compressor like your refrigerator and you may notice a hum from the compressor.
- The water from wet clothes is pumped out to your drain. You may notice a gurgling sound occasionally.

## Heat Pump Dryer Heating System

### Sealed System Theory of Operation:

Mechanical heat pumps exploit the physical properties of a volatile evaporating and condensing fluid known as a refrigerant. The heat pump compresses the refrigerant to make it hotter on the side to be warmed, and releases the pressure at the side where heat is absorbed. Refer to the diagram below for the following operations:

1. The refrigerant (R134a), in its gaseous state, is pressurized (heated) and circulated through the sealed system by the compressor.
2. The now hot and highly pressurized gas is sent to the condenser section of the heat exchanger until it condenses into a high pressure, moderate temperature liquid. The condenser heats up the process air which will be sent to the drum.
3. The condensed refrigerant then continues to the post condenser—with the help of the auxiliary fan—begins the cooling of the refrigerant.
4. The refrigerant then passes through a pressure-lowering device such as an expansion valve, or in this application, a capillary tube further decreasing the temperature of the refrigerant.
5. The low pressure liquid refrigerant then enters the evaporator section of the heat exchanger, in which the fluid absorbs heat, boils and is converted to a gas. This is accomplished when the fan blows the hot process air (from the drum) across the evaporator, which also helps to remove moisture from the humid process air. The refrigerant then returns to the compressor and the cycle is repeated.

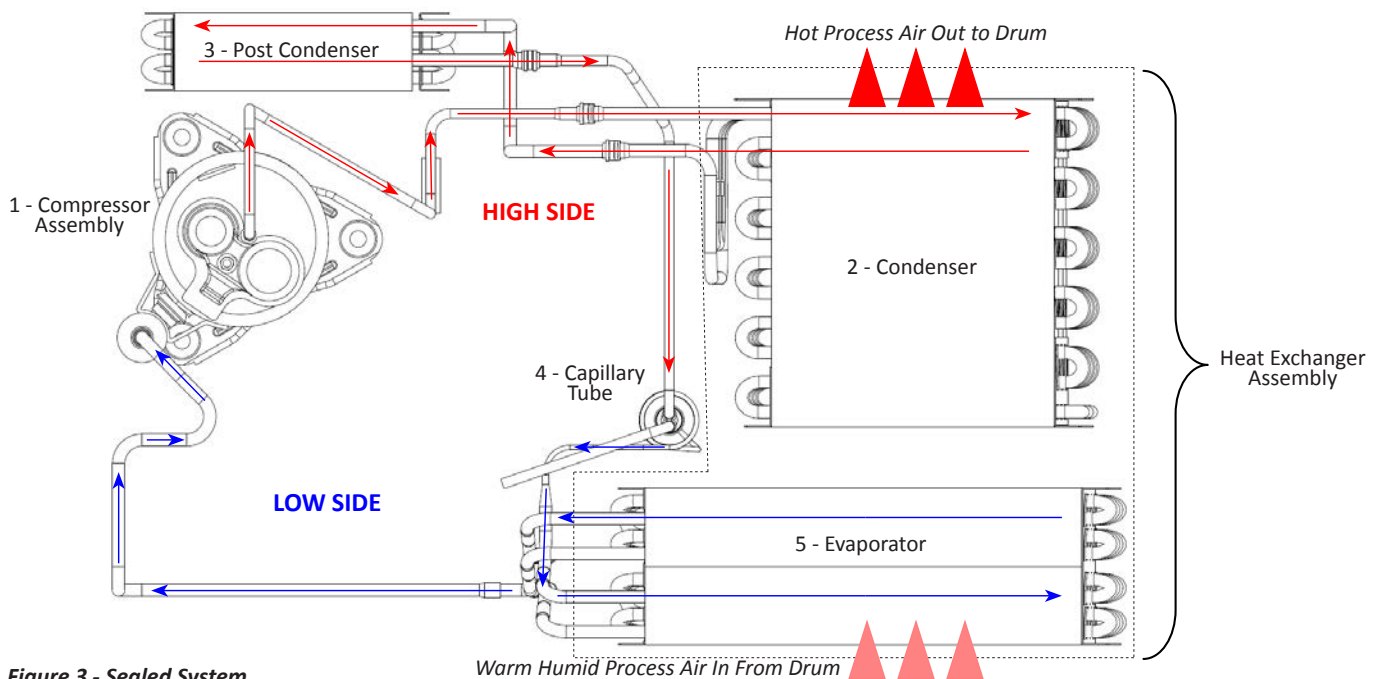

Figure 3 - Sealed System

# General Theory of Operation (continued)

## Heat Pump Dryer New Components

**Post Condenser Fan** – used for cooling the refrigerant in the post condenser. The fan is connected to J2 on the ACU.

**Drain Pump** – to drain water in the sump collected from the evaporator. The drain pump is connected to J3 on the ACU.

**Water Level Switch** – checks the water level in the sump. If the tank is full, the switch will be open. If the tank is empty, the switch will be closed. The water level switch is connected to J8 on the ACU.

**HX Filter Switch** – is a magnetic reed switch that signals the ACU when the Heat Exchanger Lint Filter is not installed. The dryer will not operate if the Heat Exchanger Filter is not detected. The filter switch is connected to J8 on the ACU.

## Whirlpool Heat Pump Compact Dryer Block Diagram

The Heat Pump Compact Dryer is not unlike its predecessor—the Whirlpool Hybrid Heat Pump Dryer. Most of the components used in the Whirlpool Hybrid Dryer are also used in the new Heat Pump Compact Dryer. Think of the compressor as the heater.

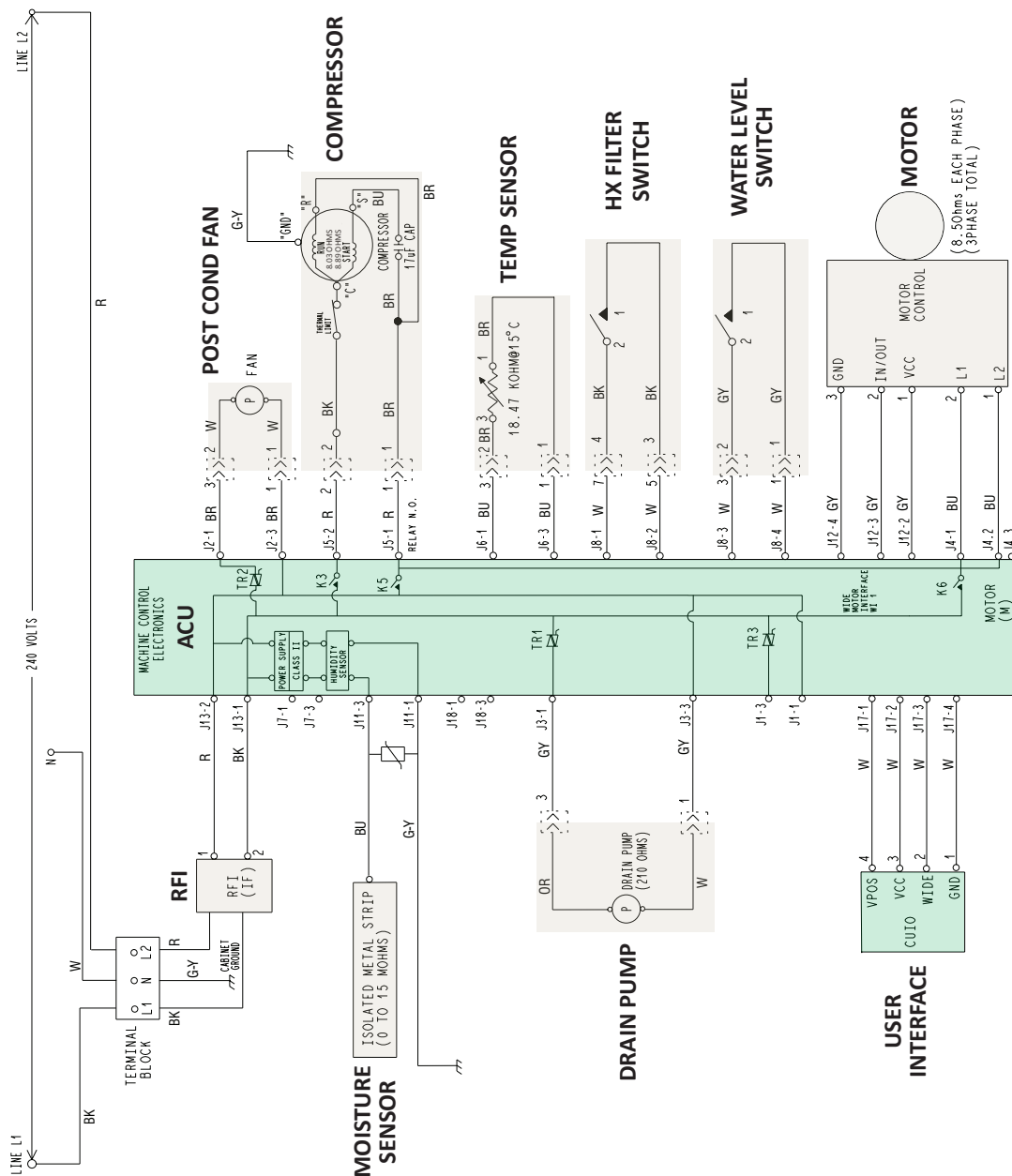
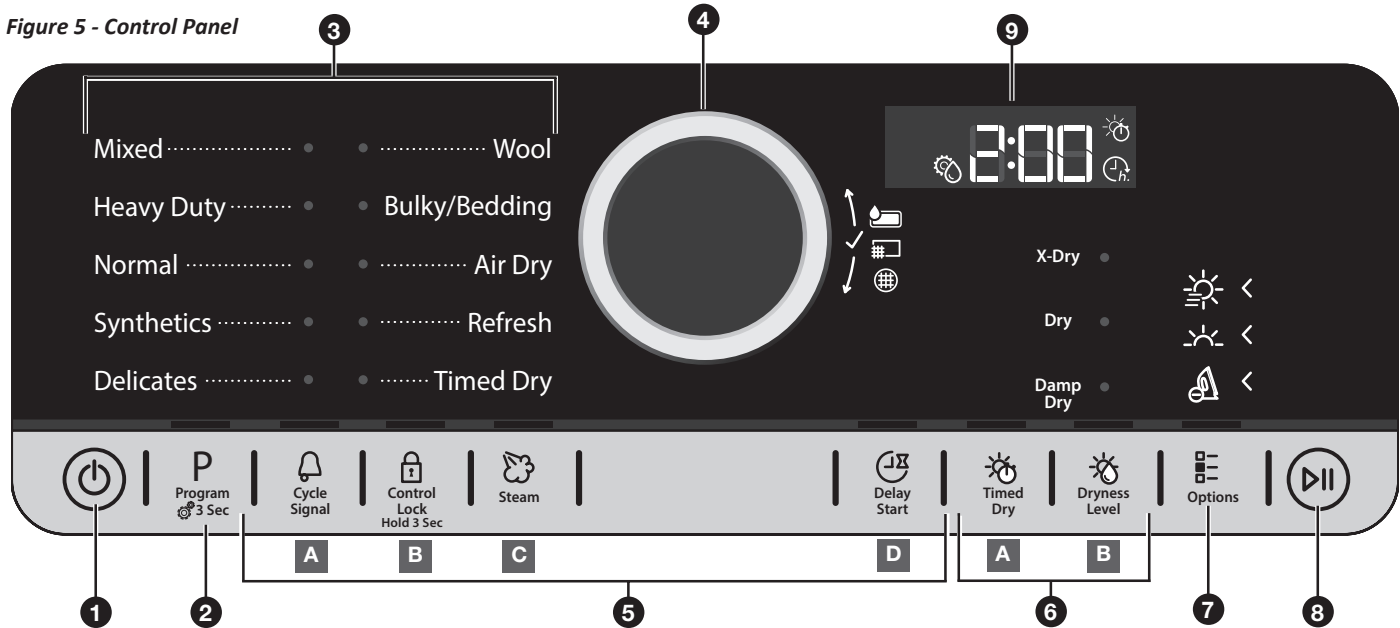

Figure 4 - Block Diagram

# Control Panel and Features

Figure 5 - Control Panel



**1 POWER BUTTON**

Touch until the indicator above the Program button lights up. Symbols appear on the control panel and sounds are played.

**2 PROGRAM (cycle)**

When you turn on the dryer, the light above this button will turn on. The program settings which you used last will appear on the control panel. This button also lets you set water conductivity.

**3 PROGRAM/CYCLE AREA**

An indicator next to each program/cycle lights up as you use the knob to scroll through the list. Press the knob when the indicator next to the desired program/cycle lights up.

**4 CONTROL KNOB**

Turn the knob to select a program/cycle for your laundry load, change dryness level, set drying time or delay start time, or select Other Options. Press the knob to confirm your selection.

**5 OPTIONS**

Touch to activate additional dry options or additional features on the dryer before touching the Start/Pause button. Additional dry options or additional features selected after touching the Start/Pause button may not be activated.

To return to factory default cycle settings, unplug the dryer for 30 seconds, then plug back in.

**NOTE:** Not all options are available with all cycles.

**A Cycle Signal**

Use to turn on or off the signal indicating the end of a drying cycle.

**NOTE:** Touch and hold the Cycle Signal button for about one second to turn sounds on or off.

**B Control Lock**

Use to lock the controls of the dryer and avoid an accidental change in cycle options or preferences during a drying cycle.

Touch and hold CONTROL LOCK to lock or unlock the controls of the dryer.

**NOTE:** The Control Lock function may be enabled when recovering from a power failure. To unlock the control, touch and hold CONTROL LOCK.

**C Steam**

Touch to activate the Steam option, which adds humidity to the end of the Heavy Duty, Normal, or Synthetics cycle to help smooth out wrinkles.

**D Delay Start**

Touch to start your program/cycle at a later time.

**6 SETTINGS**

**A Timed Dry**

Sets the length of a Timed Dry cycle.

**B Dryness Level**

When using some Automatic Cycles, you may select a Dryness Level based on the type of load you are drying.

**NOTE:** Dryness Level is for use with Automatic Cycles only.

**7 OTHER OPTIONS**

**Save Time**

This option provides quicker drying.

**Gentle**

This option dries laundry more gently by reducing the drying temperature.

**Wrinkle Shield™**

This option helps to avoid creasing if you cannot unload the laundry soon after the program/cycle ends. The dryer starts to tumble the laundry periodically a few minutes after the program/cycle ends. This tumbling will last up to approximately 12 hours. Tumbling can be stopped any time by touching the Power button to turn off the dryer.

## Control Panel and Features (continued)

### 8 START/PAUSE BUTTON

Touch to start, or touch and hold to pause, a program/cycle.

### 9 LED DISPLAY

When you select a program/cycle, its default settings will light up and the Estimated Time Remaining will be displayed. Factors such as load size and dryness level may affect the time shown in the display.

#### Symbols



Drying time



Delay start



Conductivity adjustment

### STATUS INDICATORS (next to control knob)

These indicators will light up to alert you when certain conditions occur.

#### Symbols



Water tank full (see “Empty Water Tank” in “Using Your Dryer”)



Clean bottom filter (see “Cleaning the Bottom Filter” in “Dryer Care”)



Clean door filter (see “Cleaning the Lint Screen” in “Dryer Care”)

## Dryer Maintenance

### Empty Water Tank (Figure 6)

Hold the handle and carefully pull out the water tank. Holding the full water tank with both hands, empty out the water. Then push the container back into place. Make sure that it is properly inserted.

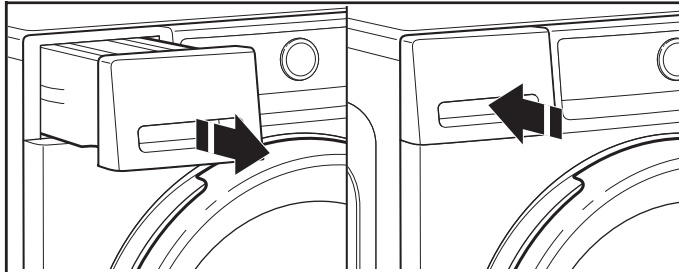

Figure 6 - Empty Water Tank

### Clean Door Lint Screen (Figure 7)

Clean the lint screen before each load. Pull the lint screen straight up and out. Press tab down and open lint screen. Roll lint off the screen with your fingers. Push the lint screen firmly back into place.

**IMPORTANT:** Clean lint screen before each dryer use as a screen blocked with lint will increase drying time.

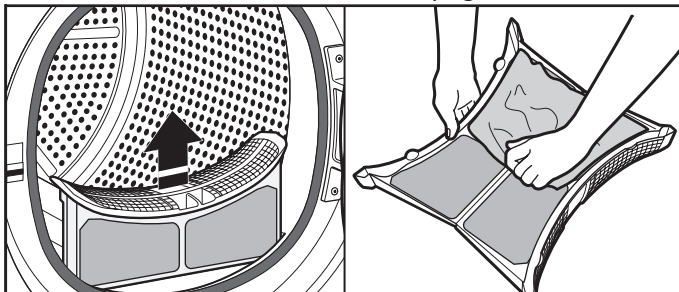

Figure 7 - Door Lint Screen

### Clean Bottom Filter (Figure 8)

Clean the bottom filter after every 5 cycles. Open the filter door on the bottom of the dryer and grab the handle to pull out filter. Remove the foam from the bottom filter. Clean the filter foam and filter by hand or rinse with water – do not wash the filter foam in a washer. Wring out the filter foam – do not insert it in the bottom filter dripping wet.

Replace the filter foam on the bottom filter. Replace the bottom filter in the filter chamber. Fold the filter handle down and close the bottom door.

**NOTE:** To turn off the “Clean bottom filter” (☐) status indicator, the filter must be removed and replaced with the Power button touched ON and no cycle running.

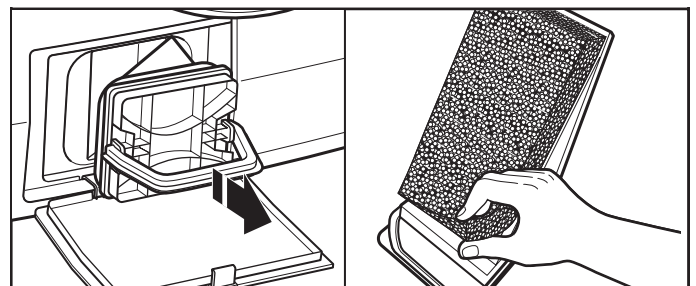

Figure 8 - Clean Bottom Filter

## GENERAL INFORMATION

---

### Model & Serial Number Location

**NOTE:** First 5000 dryers - will have the model/serial number tag on the console behind the removable water tank drawer.



*Figure 9 - Model / Serial Number*

### Tech Sheet Location

**Tech Sheet Location  
(Inside right side panel)**

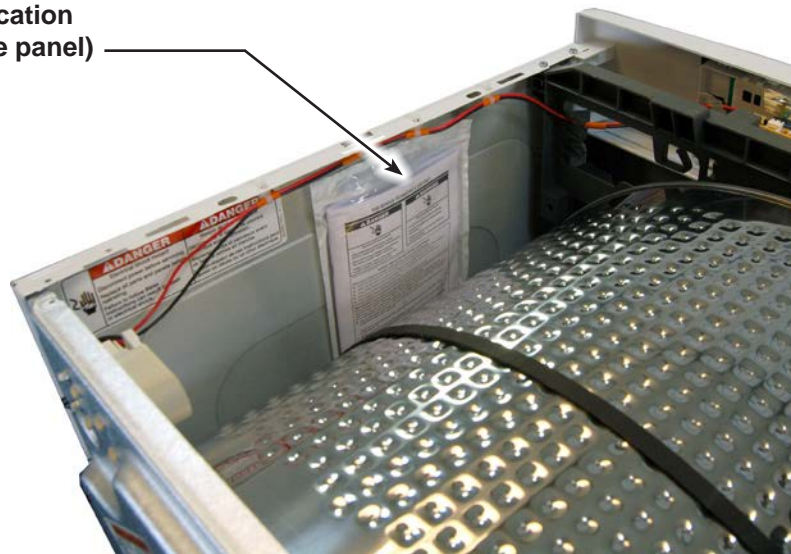

*Figure 10 - Tech Sheet Location*

## Model & Serial Number Nomenclature

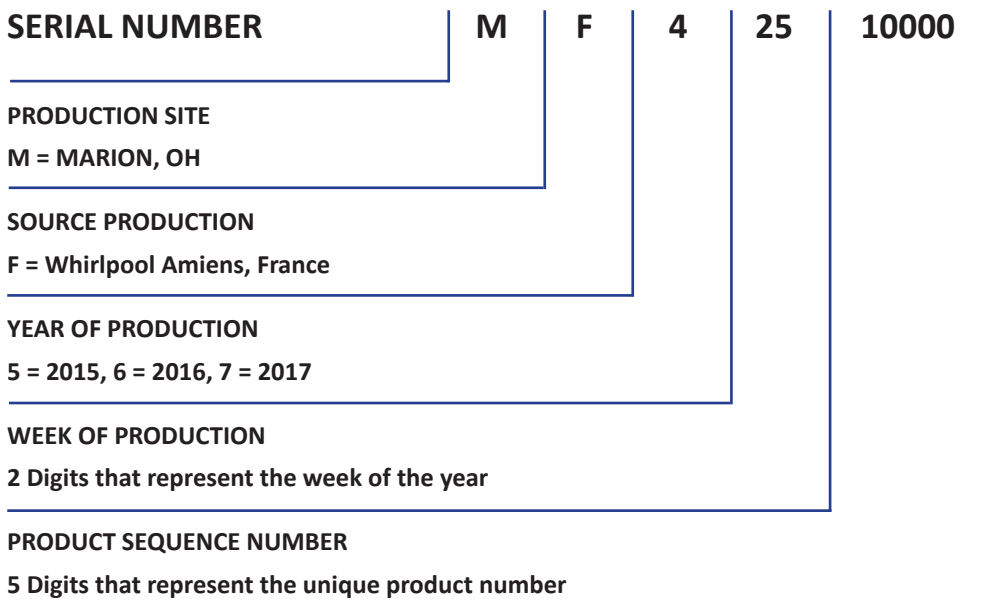
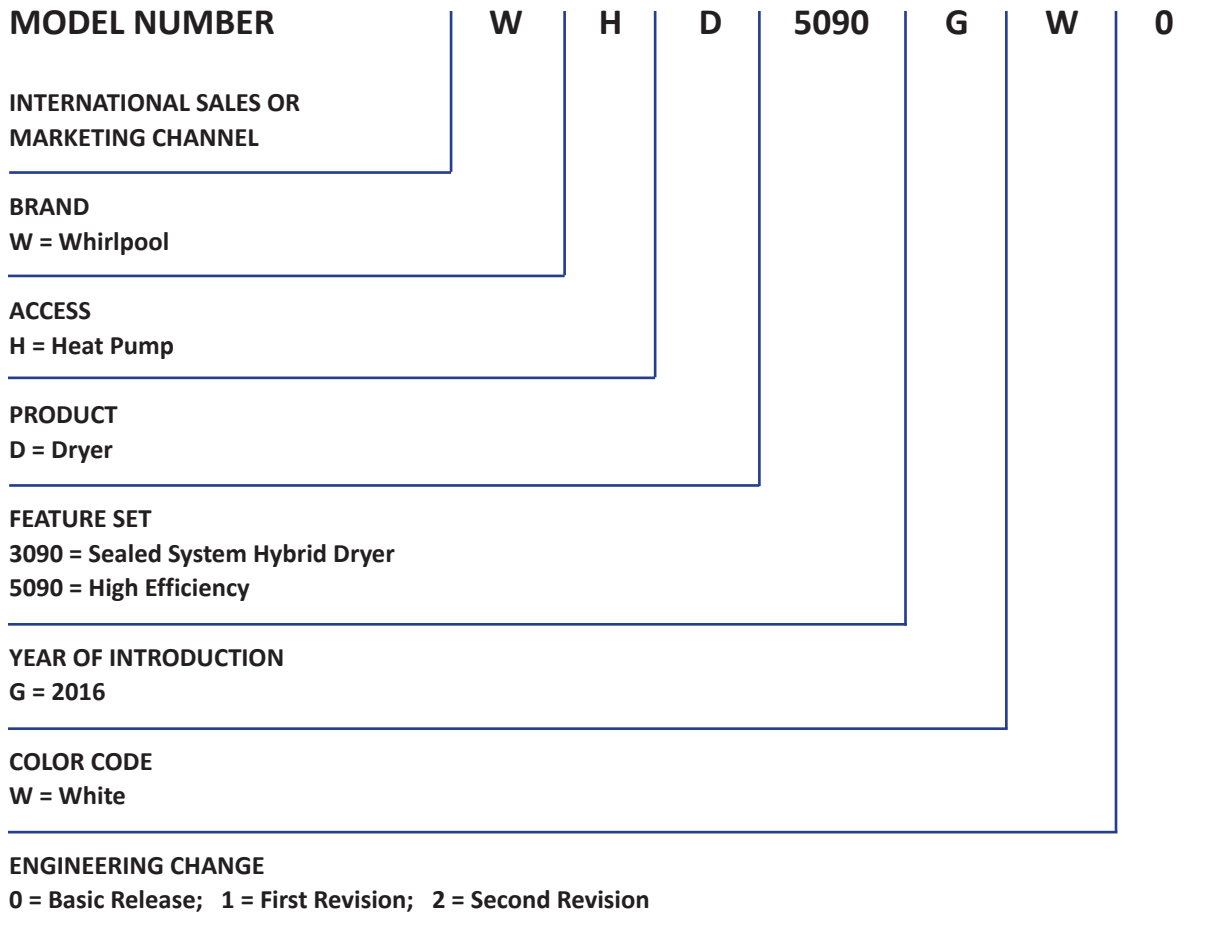

## Product Specifications

ELECTRICAL	
Line Voltage :	240 VAC (200-260) Elect. Dryer, 2-phase, "optimized" 208 VAC (176-229) Elect. Dryer, 3-phase, "less optimized"
Frequency :	58 to 62 Hz (60 Hz nominal)
Amps :	30 Amp Service
PRIMARY FEATURES	
Capacity :	4.3 Cu. Ft.
Control Panel :	Capacitive Touch / Electronic
Drum Material :	Stainless Steel
Sound Package :	Yes
Energy Star® Qualified :	Yes
Cycles :	(10) Air Dry, Bulky Items, Delicates, Heavy Duty, Mixed, Normal, Refresh, Synthetics, Timed Dry, Wool
Status Indicators :	(4) Bottom Filter Clogged, Delay Start, Door Filter Clogged, Water Tank Full
Dryness Levels :	(3) Damp Dry, Dry, Extra Dry
Filters :	Primary Lint Filter, Heat Pump Filter
Secondary Lint Filter :	Yes
Automatic Dry Control :	Yes
Cycle Time Remaining :	Yes
Moisture Sensor :	Yes
INSTALLATION CONSIDERATIONS	
Venting Direction :	Ventless
Stackable :	Yes
Door Reversal :	Yes (see Installation section)
Water Drain :	Standpipe or laundry sink
OPTIONS	
Dryer Option Selections :	Delay Start, Gentle, Save Time, Steam, Wrinkle Shield
Cycle Signal :	Turn signal indicating end of cycle on or off
Control Lock :	Locks the controls
DIMENSIONS	
Height :	33.5" (85.09 cm) Max
Width :	24" (60.96 cm)
Depth :	26" (66.04 cm)
Depth with door open :	43.31" (110.0 cm)
Gross Weight :	101.20 lbs. (45.90 kg)

## Section 2: Diagnostics & Troubleshooting

This section provides diagnostic, fault codes, and troubleshooting information for the “Whirlpool Compact Heat Pump Dryer.”

- Control Panel
- Abbreviations
- Diagnostic Guide
- Service Diagnostic Mode/Service Test Cycle
- Activating Service Diagnostic Mode
- Service Test Cycle
- Service Test Cycle Chart
- Fault/Error Codes
- Troubleshooting Guide

For Service Technician Use Only

CONTROL PANEL (buttons to use when entering Service Diagnostic Mode/Service Test Cycle

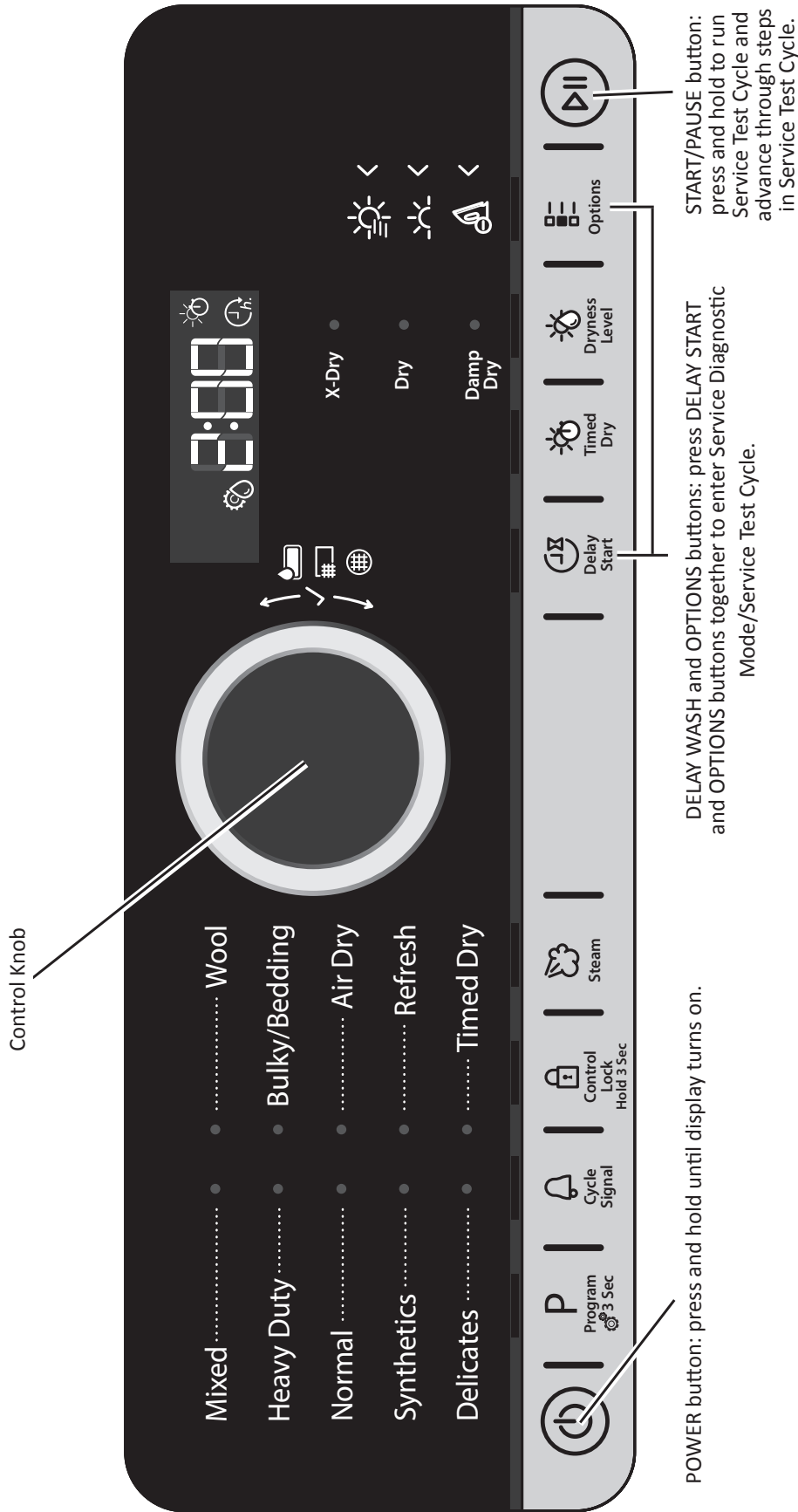

Figure 2 - User Interface

## For Service Technician Use Only

### ABBREVIATIONS

**ACU:** Appliance Control Unit

**UI:** User Interface (PCB & housing)

### ICONS

 Water tank is filled with water or improperly positioned

 Bottom filter is blocked by lint or improperly positioned

 Door filter is blocked by lint or improperly positioned

### DIAGNOSTIC GUIDE

Before servicing, check the following:

- Make sure there is power at the wall outlet.
- Has a household fuse blown or circuit breaker tripped? Was a regular fuse used? Inform customer that a time-delay fuse is required.
- Make sure the dryer fan, lint screen, and secondary lint filter are clear of lint and obstructions.
- All tests/checks should be made with a VOM (volt-ohm-milliammeter) or DVM (digital-voltmeter) having a sensitivity of 20,000  $\Omega$  per volt DC or greater.
- Resistance checks must be made with dryer unplugged or power disconnected.
- Voltage checks must be made with all connectors attached to the boards.
- **IMPORTANT:** Avoid using large diameter probes when checking harness connectors as the probes may damage the connectors upon insertion.
- Check all harnesses and connections before replacing components. Look for connectors not fully seated, broken or loose wires and terminals, pin insertion, or wires not pressed into connectors far enough to engage metal barbs.
- A potential cause of a control not functioning is corrosion or contamination on connections. Use an ohmmeter to check for continuity across suspected connections.

### SERVICE DIAGNOSTIC MODE/ SERVICE TEST CYCLE

Allows service personnel to run the Service Test Cycle to verify inputs to the dryer and functionality of the dryer control. You may want to do a quick and overall checkup of the dryer with this test before going to specific troubleshooting tests.

### ACTIVATING SERVICE DIAGNOSTIC MODE

**IMPORTANT:** Use Service Diagnostic Mode without laundry in the dryer.

See the chart on page 5 for a summary of the steps in the Service Test Cycle.

To enter Service Diagnostic Mode:

1. Be sure the dryer is in standby mode (plugged in with all indicators off).
2. Open and close the dryer door. The door must be closed to enter Service Diagnostic Mode.
3. Press and hold **POWER** until the dryer display turns on with indicators scrolling from left to right. When the time remaining display turns on, within a few seconds:
4. Press and hold **DELAY START** and **OPTIONS** until display shows "FC" (the dryer will count down "3-2-1" before displaying "FC"). Turn the cycle selector knob one click to the right until display shows "SC" for Service Test Cycle. Rotating the cycle selector knob will toggle the display between "SC" (Service Test Cycle) and "FC" (Factory Test Cycle).

**DO NOT SELECT OR RUN "FC" (FACTORY TEST CYCLE), AS IT IS FOR FACTORY TEST PURPOSES ONLY AND REQUIRES THE FACTORY ENVIRONMENT AND TEST EQUIPMENT.** The START LED will be flashing slowly. Immediately press **START**. The control will beep and the display will show "500".

# For Service Technician Use Only

## SERVICE TEST CYCLE

Refer the “Service Test Cycle Charts” on page 2-5 for the following steps.

### S00

Checks the lint/Heat Exchanger (HX) filter status. Press **START** to go to next step.

### S01

Press **START** again; the display will go blank for less than one second and then the bottom row icon LEDs will flash. Press each bottom row icon from left to right and corresponding LEDs on the control panel will light and go out accompanied by a beep. Turn the cycle selector knob to the left one click at a time. The seven segment display will light up one segment at a time corresponding to the turning of the knob. Now, turn the cycle selector knob to the right until the outside of the seven segment display has lit up, then press the cycle selector knob. Press **START** to go to the next step.

### S02

Checks the motor status; this routine starts the motor movement in a clockwise direction. Press **START** to go to next step.

### S03

Checks the motor status, but in a counterclockwise direction. Also turns on the drain pump. Press **START** to go to next step.

### S04

Checks the float switch, moisture sensor, and drain pump. The float switch and pump are verified by performing a manual fill: remove the top panel and the water tank, add water directly to the black water tank cavity of the dryer until the water tank icon turns on and the pump activates. Put the water tank back into place; the water added to the back hole will now fill the container. After container is filled, wait 60 seconds for the icon and the pump to turn off.

The humidity (moisture) sensor check is achieved by resistance value: See Test #5: Moisture Sensor, page 18.

Press **START** to go to next step.

### S05

Verifies the status of the compressor by monitoring the temperature: if the temperature increases at the condenser NTC (thermistor) in a specific period of time and the display shows, for example, “t24”, “t25”, etc., then the compressor is OK. If not, “F23” will be displayed. Press **START** to go to the next step.

### S06

Verifies post condenser fan functionality. Press **START** to go to next step.

### S07

The last error code detected by the dryer will be displayed. Press **START** to exit Service Test Cycle.

## Activation with Saved Fault Codes

If there is a saved fault code, the F number will be shown in the display. Only one active fault code can be displayed. If no fault codes are stored, the display shows “S07” and “F00” alternately. Review the Fault/Error Codes beginning on page 6 for the recommended procedure.

## Unsuccessful Activation

If entry into Service Diagnostic Mode is unsuccessful, refer to the following indications and actions:

**Indication 1:** None of the indicators or display turn on.

**Action:** Make sure AC power is available to the dryer.

**Indication 2:** Display is on, but unable to enter Service Diagnostic Mode.

**Action:** Press and hold **POWER** until “3-2-1” and then “rES” appears in the display. Turn off the dryer display. Wait 10 seconds. Turn on the dryer display. Follow the Activating Service Diagnostic Mode instructions on page 3.

## Exit Procedure

To exit the Service Test Cycle, press and hold **POWER** or open and close the door.

## For Service Technician Use Only

## SERVICE TEST CYCLE CHART—HEAT PUMP DRYER

Step No.	Test/Tested Component	Description	Output Status			
			Compressor	Fan	Motor	Pump
S00	Service Test	Heat Exchanger (HX) Filter Test	OFF	OFF	OFF	OFF
S01	Service Test	Display and Button Test	OFF	OFF	OFF	OFF
S02	CW	Clockwise Motor	OFF	OFF	CW	OFF
S03	CCW	Counterclockwise Motor, Pump ON	OFF	ON	CCW	ON
S04	Humidity + Pump	Humidity (Moisture Sensor) Test - Pump and Float Switch Test	OFF	OFF	OFF	Test (see SO4, page 4)
S05	Compressor	5.1 Automatic Compressor Test	ON	OFF	OFF	OFF
		5.2 Extended Compressor Test	ON	OFF	OFF	OFF
		5.3 Extended Compressor Test	OFF	OFF	OFF	OFF
		Finished, Waiting to Press START				
S06	Fan	Fan (Post Condenser)	OFF	ON	OFF	OFF
S07	Display last error code	Last Error Code is Displayed	OFF	OFF	OFF	OFF
EXIT	Exit Service Diagnostic Mode/ Service Test Cycle	Go to Selection				

## For Service Technician Use Only

**⚠ WARNING**



**Electrical Shock Hazard**

**Disconnect power before servicing.**

**Replace all parts and panels before operating.**

**Failure to do so can result in death or electrical shock.**

### FAULT/ERROR CODES – HEAT PUMP DRYER



(Refer to Fault/Error code charts on pages 7–13.)

#### Activation with Saved Fault Codes

If there is a saved fault code, the F number will be shown in the display. Only one active fault code can be displayed. If no fault codes are stored, the display shows “S07” and “F00” alternately. Review the Fault/Error Codes beginning on page 6 for the recommended procedure.

#### Exit Procedure

To exit the Service Test Cycle, press and hold **POWER** or open and close the door.

Icon Display	Text Display	Explanation and Recommended Procedure
		<p><b>Water Tank Filled With Water</b></p> <ul style="list-style-type: none"> <li>Empty water tank; make sure to put it back into position properly. If icon stays on, see Tests #8 &amp; #9, pages 20–21.</li> </ul> <p><b>Water Tank Not Positioned Properly</b></p> <ul style="list-style-type: none"> <li>Push in the water tank to make sure that it is fully inserted in the tank compartment.</li> </ul>
		<p><b>Bottom Filter Blocked By Lint</b></p> <ul style="list-style-type: none"> <li>Remove and clean the bottom filter; make sure to put it back into position properly. If icon stays on, see Test #11, page 22.</li> </ul> <p><b>Bottom Filter Not Positioned Properly</b></p> <ul style="list-style-type: none"> <li>Push in the bottom filter and move the release levers into horizontal position to make sure that the filter is fully inserted in the filter compartment. Close the flap.</li> </ul>
		<p><b>Door Filter Blocked By Lint</b></p> <ul style="list-style-type: none"> <li>Remove and clean the door filter; make sure to put it back into position properly.</li> </ul> <p><b>Door Filter Not Positioned Properly</b></p> <ul style="list-style-type: none"> <li>Check the position of the door filter. Make sure it is fully inserted.</li> </ul>
	<i>F01</i>	<p><b>Main Relay Defect</b></p> <ul style="list-style-type: none"> <li>Perform reset procedure (turn on the dryer, then press and hold <b>POWER</b> until “3-2-1” and then “rES” appears in the display). Perform Tests #1, #2, and #3, pages 12–14. If they fail, replace the ACU.</li> </ul>
	<i>F02</i>	<p><b>Corrupted EEPROM</b></p> <ul style="list-style-type: none"> <li>Follow same procedure as for F01.</li> </ul>
	<i>F03</i>	<p><b>Humidity (Moisture) Sensor Failure</b></p> <ul style="list-style-type: none"> <li>Perform reset procedure (turn on the dryer, then press and hold <b>POWER</b> until “3-2-1” and then “rES” appears in the display). Try to run a cycle; if the issue persists, turn off and unplug the dryer, check ACU connections and harness, and perform Test #5, page 18.</li> </ul>
	<i>F04</i>	<p><b>Relay Failure (K002 or K003)</b></p> <ul style="list-style-type: none"> <li>Follow same procedure as for F01.</li> </ul>

Continued on following page . . .

## For Service Technician Use Only

## FAULT/ERROR CODES – HEAT PUMP DRYER (Continued)

Icon Display	Text Display	Explanation and Recommended Procedure
	<i>F06</i>	<b>Heat Exchanger (HX) NTC (Thermistor) Value Too High or Too Low</b> <ul style="list-style-type: none"> <li>Perform reset procedure (turn on the dryer, then press and hold <b>POWER</b> until “3-2-1” and then “rES” appears in the display). Try to run a cycle; if the issue persists, turn off and unplug the dryer, check ACU connections and harness, and perform Test #4C, Compressor Thermistor section, page 18. <b>Note:</b> Make sure there is no laundry inside the dryer, and that the ambient temperature of the laundry area is between 41°F (5°C) and 95°F (35°C).</li> </ul>
	<i>F07</i>	<b>Motor Movement Defect/Broken Drum Belt</b> <ul style="list-style-type: none"> <li>Perform reset procedure (turn on the dryer, then press and hold <b>POWER</b> until “3-2-1” and then “rES” appears in the display). Try to run a cycle; if the issue persists, turn off and unplug the dryer, check ACU connections and harness, and perform Test #3, page 14. <b>Note:</b> Make sure there is no laundry inside the dryer.</li> </ul>
	<i>F10</i>	<b>MCU Communication Error (No Communication Between ACU and MCU)</b> <ul style="list-style-type: none"> <li>MCU issue. Follow same procedure as for F07.</li> </ul>
	<i>F11</i>	<b>MCU Motor Failure</b> <ul style="list-style-type: none"> <li>Follow same procedure as for F07.</li> </ul>
	<i>F12</i>	<b>MCU Not Reset</b> <ul style="list-style-type: none"> <li>Follow same procedure as for F07.</li> </ul>
	<i>F14</i>	<b>Undervoltage Condition</b> <ul style="list-style-type: none"> <li>Perform reset procedure (turn on the dryer, then press and hold <b>POWER</b> until “3-2-1” and then “rES” appears in the display). Try to run a cycle; if the issue persists, turn off and unplug the dryer, check ACU connections and harness, and perform Tests #1, #2, &amp; #3, pages 12–14. <b>Note:</b> Make sure there is no laundry inside the dryer.</li> </ul>
	<i>F15</i>	<b>MCU Failure (Rectifier Diode Shorted/Open)</b> <ul style="list-style-type: none"> <li>Follow same procedure as for F07.</li> </ul>
	<i>F18</i>	<b>MCU Over Temperature</b> <ul style="list-style-type: none"> <li>Follow same procedure as for F07, except wait several minutes for the dryer to cool after it is turned off and unplugged.</li> </ul>
	<i>F19</i>	<b>MCU Over Voltage</b> <ul style="list-style-type: none"> <li>Follow same procedure as for F14.</li> </ul>
	<i>F20</i>	<b>Motor Over Current</b> <ul style="list-style-type: none"> <li>Follow same procedure as for F14.</li> </ul>
	<i>F21</i>	<b>UI Communication Error (No Communication Between ACU and UI)</b> <ul style="list-style-type: none"> <li>UI issue. Perform Test #12, page 22.</li> </ul>
	<i>F22</i>	<b>ACU Communication Error (No Communication Between ACU and UI)</b> <ul style="list-style-type: none"> <li>ACU issue. Perform Test #12, page 22.</li> </ul>
	<i>F23</i>	<b>Compressor Defect</b> <ul style="list-style-type: none"> <li>Perform reset procedure (turn on the dryer, then press and hold <b>POWER</b> until “3-2-1” and then “rES” appears in the display). Try to run a cycle; if the issue persists, turn off and unplug the dryer, check ACU connections and harness, and perform Test #4b, page 15.</li> </ul>
	<i>F24</i>	<b>Fan Defect</b> <ul style="list-style-type: none"> <li>Perform reset procedure (turn on the dryer, then press and hold <b>POWER</b> until “3-2-1” and then “rES” appears in the display). Try to run a cycle; if the issue persists, turn off and unplug the dryer, check ACU connections and harness, and perform Test #10, page 21.</li> </ul>

## For Service Technician Use Only

### Troubleshooting Guide

**NOTE: Always check for error codes first (pages 2-8 to 2-11)**

Some tests will require accessing components. See Section 4, "Component Access" for component locations. For detailed testing procedures, refer to Section 3, "Component Testing."

Problem	Possible Causes	Checks & Tests
<b>Dryer Operation</b>		
<b>WILL NOT POWER UP</b> <ul style="list-style-type: none"> <li>• No operation</li> <li>• No keypad response</li> <li>• No LEDs or display</li> </ul>	No power to dryer.	Check power at outlet; check circuit breaker, fuses, or junction box connections.
	Connection problem between AC plug and dryer.	See TEST #2: Supply Connections, page 13.
	Connection problem between ACU and UI.	Check connections and harness continuity between ACU and UI.
	Power supply not present at machine electronics.	See TEST #1: ACU Power Check, page 12.
	User Interface problem.	See TEST #6: Buttons & Indicators, page 19.
<b>WILL NOT START CYCLE</b> (No response when Start is pressed)	Door filter or bottom lint filter not present or not positioned properly (filter icon showing in display).	Place door filter or bottom lint filter into position and make sure it is fully inserted. See TEST #11: Heater Exchange Switch, page 22.
	Door not fully closed/not striking the door latch.	Be sure the door is completely closed, then press and hold START.
	Door switch problem.	See TEST #7: Door Switch, page 20.
	Drive belt problem.	See TEST #3: Motor Circuit, page 14.
	Motor problem.	See TEST #3: Motor Circuit, page 14.
	User Interface or communication problem.	See TEST #6: Buttons & Indicators, page 19 and TEST #12: Communication Between UI and ACU, page 22.
	ACU problem.	See TEST #1: ACU Power Check, page 12.
<b>WILL NOT SHUT OFF WHEN EXPECTED</b>	Poor airflow.	Check lint filters and fan. Clean if necessary.
	Start/Pause button problem.	See TEST #6: Buttons & Indicators, page 19.
	Moisture sensor problem.	See TEST #5: Moisture Sensor, page 18.
	NTC thermistor problem.	See TEST #4c: Thermistors, page 17.
	User Interface or communication problem.	See TEST #6: Buttons & Indicators, page 19 and TEST #12: Communication Between UI and ACU, page 22.
	ACU problem.	See TEST #1: ACU Power Check, page 12.
<b>CONSOLE WON'T ACCEPT SELECTIONS</b>	User selected invalid option.	Refer customer to Use & Care Guide.
	User Interface or communication problem.	See TEST #6: Buttons & Indicators, page 19 and TEST #12: Communication Between UI and ACU, page 22.
<b>DRUM WILL NOT SPIN</b>	Drive belt problem.	See TEST #3: Motor Circuit, page 14.
	Door switch problem.	See TEST #7: Door Switch, page 20.
	Motor problem.	See TEST #3: Motor Circuit, page 14.
	ACU problem.	See TEST #1: ACU Power Check, page 12.

Continued on following page . . .

## For Service Technician Use Only

### Troubleshooting Guide (continued)

Problem	Possible Causes	Checks & Tests
<b>WILL NOT HEAT</b>	Check installation.	Verify proper dryer installation.
	Check for L1 and L2.	See TEST #2: Supply Connections, page 13.
	Heater system malfunction.	See TEST #4: Heat System, page 14.
	NTC thermistor problem.	See TEST #4c: Thermistors, page 17.
	ACU problem.	See TEST #1: ACU Power Check, page 12.
<b>HEATS IN AIR CYCLE</b>	Heater coil shorted.	See TEST #4: Heat System, page 14.
	Heater relay shorted.	See TEST #4: Heat System, page 14.
	Heater system problem.	See TEST #4: Heat System, page 14.
	NTC thermistor problem.	See TEST #4c: Thermistors, page 17.
<b>SHUTS OFF BEFORE CLOTHES ARE DRY</b>	Lint filters are full/plugged.	Clean if necessary. Refer customer to Use & Care Guide.
	Dryness setting for auto cycles.	Increase dryness level setting for one or more auto cycles, along with conductivity (Customer-Focused Dryness Level) setting (see TEST #5a).
	Moisture sensor problem.	See TEST #5: Moisture Sensor, page 18.
	NTC thermistor problem.	See TEST #4c: Thermistors, page 17.
<b>Unusual Noise</b>		
<b>THUMPING NOISE</b>	Dryer hasn't been used in a while.	This is due to temporary flat spots on the drum rollers. The thumping sound will diminish after a few minutes.
<b>RATTLING OR VIBRATING NOISE</b>	A small object caught between the edges of dryer drum.	Check the front and rear edges of the drum for small objects. Clean out pockets before laundering.
	Dryer isn't properly leveled.	The dryer may vibrate if not properly installed. See "Installation Instructions." All four dryer feet should be in firm contact with the floor.
	Clothing is balled up in dryer.	When balled up, the load will bounce, causing the dryer to vibrate. Separate the load items and restart the dryer.
<b>LOUD HUMMING OR INCREASED NOISE DURING CYCLE</b>	Load is packed tightly.	Reduce load size to recommended load size in "Program/Cycle Guide." Run the dryer for 5–10 minutes.
<b>Dryer Results</b>		
<b>CLOTHES ARE NOT DRYING SATISFACTORILY OR DRYING TIMES ARE TOO LONG</b>	Lint screen is clogged with lint.	Clean lint screen before each load.
	Bottom filter and screen is clogged with lint.	Clean bottom filter after every 5th cycle.
	Clothes not contacting the moisture sensors during Automatic Cycles.	Check that the dryer is level.
	The load is too large and heavy to dry quickly.	Separate the load to tumble freely
	Fabric softener sheets are blocking the grille.	The air outlet grille is just inside the door. Check that it is not blocked by a fabric softener sheet. Use only one fabric softener sheet, and use it only once.
	The dryer is located in a room with temperature below 45°F (7°C).	Proper operation of dryer cycles requires temperatures above 5°F (7°C).
	The dryer is located in a closet.	Closet doors must have ventilation openings at the top and bottom of the door. The front of the dryer requires a minimum of 1" (25 mm) of airspace, and, for most installations, the rear of the dryer requires 5" (127 mm).

Continued on following page . . .

**For Service Technician Use Only**

**Troubleshooting Guide (continued)**

<b>Problem</b>	<b>Possible Causes</b>	<b>Checks &amp; Tests</b>
<b>THERE MAY BE SOME WATER IN THE BOTTOM FILTER OR ON FLOOR</b>	The dryer is not level.	Floor needs to have a slope less than 1" (25 mm).
	Bottom filter is not properly seated.	Make sure filter is placed in the housing cabinet correctly.
	Drain hose is longer than what was provided. Verify water container and hose connections.	Drain hose can be installed no higher than 36" (91 cm) from bottom of the dryer.
<b>CYCLE TIME IS TOO SHORT</b>	The load may not be contacting the sensor strips on Automatic Cycles.	Level the dryer. All four dryer feet should be in firm contact with the floor.
	The Automatic Cycle is ending early.	Change the dryness level setting on Automatic Cycles. Increasing or decreasing the dryness level will change the amount of drying time in a cycle.
<b>LINT ON LOAD</b>	Lint screen is clogged with lint.	Clean lint screen before each load.
<b>STAINS ON LOAD</b>	Improper use of fabric softener.	Add dryer fabric softener sheets at the beginning of the cycle. Fabric softener sheets added to a partially dried load can stain your garments. Do not use fabric softener sheets with steam cycles.
<b>STAINS ON DRUM</b>	Loose dyes in clothes.	Drum stains are caused by dyes in clothing (usually blue jeans). These will not transfer to other clothing.
<b>LOADS ARE WRINKLED</b>	The load was not removed from dryer at the end of the cycle.	Refer to garment care label instructions. Dry-clean-only garments are not recommended.
	The dryer was tightly packed.	Dry smaller loads that can tumble freely. Results may also vary depending on fabric type.
<b>ODORS</b>	Recent painting, staining, or varnishing in the area where your dryer is located.	Ventilate the area. When the odors or fumes are gone from the area, rewash and dry the clothing.
	Odors are left in garments after wearing.	Rewash and dry the clothing.
<b>LOAD TOO HOT</b>	Load removed before cool-down portion of cycle complete.	Allow the dryer to complete the cool-down portion of the cycle before removing the load.
<b>STAINS OR LINT BUILDUP ON WALL BEHIND DRYER</b>	Dryer too close to wall.	Move dryer away from wall and make sure you have proper ventilation.

**Notes**

## Section 3:

# Component Testing

This section provides a wiring diagram, control board specifications, testing procedures and strip circuits for the “Whirlpool Compact Heat Pump Dryer.”

- Testing: Safety Information
- Wiring Diagram
- Component Testing
- TEST #1: ACU Power Check
- TEST #2: Supply Connections (IF)
- TEST #3: Motor Circuit (M)
- TEST #4: Heating System (Compressor)
- TEST #4A: Heat Pump (HE)
- TEST #4C: Thermistor (SET2)
- TEST #5: Moisture Sensor (SEH)
- TEST #5A: Adjusting Customer-Focused Dryness Level
- TEST #6: Buttons and Indicators
- TEST #7: Door Switch (ACU)
- TEST #8: Drain Pump (DP)
- TEST #9: Water Level Switch (SLE)
- TEST #10: Auxiliary Fan (FM)
- TEST #11: Heater Exchange Switch (HX)
- TEST #12: Communications Between UI and ACU (W12)

## For Service Technician Use Only

<b>⚠ DANGER</b>

<b>Electrical Shock Hazard</b>
<p>Only authorized technicians should perform diagnostic voltage measurements.</p> <p>After performing voltage measurements, disconnect power before servicing.</p> <p>Failure to follow these instructions can result in death or electrical shock.</p>

<b>⚠ WARNING</b>

<b>Electrical Shock Hazard</b>
<p>Disconnect power before servicing.</p> <p>Replace all parts and panels before operating.</p> <p>Failure to do so can result in death or electrical shock.</p>

### Voltage Measurement Safety Information

When performing live voltage measurements, you must do the following:

- Verify the controls are in the off position so that the appliance does not start when energized.
- Allow enough space to perform the voltage measurements without obstructions.
- Keep other people a safe distance away from the appliance to prevent potential injury.
- Always use the proper testing equipment.
- After voltage measurements, always disconnect power before servicing.

#### **IMPORTANT: Electrostatic Discharge (ESD) Sensitive Electronics**

ESD problems are present everywhere. Most people begin to feel an ESD discharge at approximately 3000V. It takes as little as 10V to destroy, damage, or weaken the main control assembly. The new main control assembly may appear to work well after repair is finished, but a malfunction may occur at a later date due to ESD stress.

- Use an anti-static wrist strap. Connect wrist strap to green ground connection point or unpainted metal in the appliance

-OR-

- Touch your finger repeatedly to a green ground connection point or unpainted metal in the appliance.
- Before removing the part from its package, touch the anti-static bag to a green ground connection point or unpainted metal in the appliance.
- Avoid touching electronic parts or terminal contacts; handle electronic control assembly by edges only.
- When repackaging main control assembly in anti-static bag, observe above instructions.

#### **IMPORTANT SAFETY NOTICE — “For Technicians only”**

This service data sheet is intended for use by persons having electrical, electronic, and mechanical experience and knowledge at a level generally considered acceptable in the appliance repair trade. Any attempt to repair a major appliance may result in personal injury and property damage. The manufacturer or seller cannot be responsible, nor assume any liability for injury or damage of any kind arising from the use of this data sheet.

# For Service Technician Use Only

## HEAT PUMP DRYER WIRING DIAGRAM

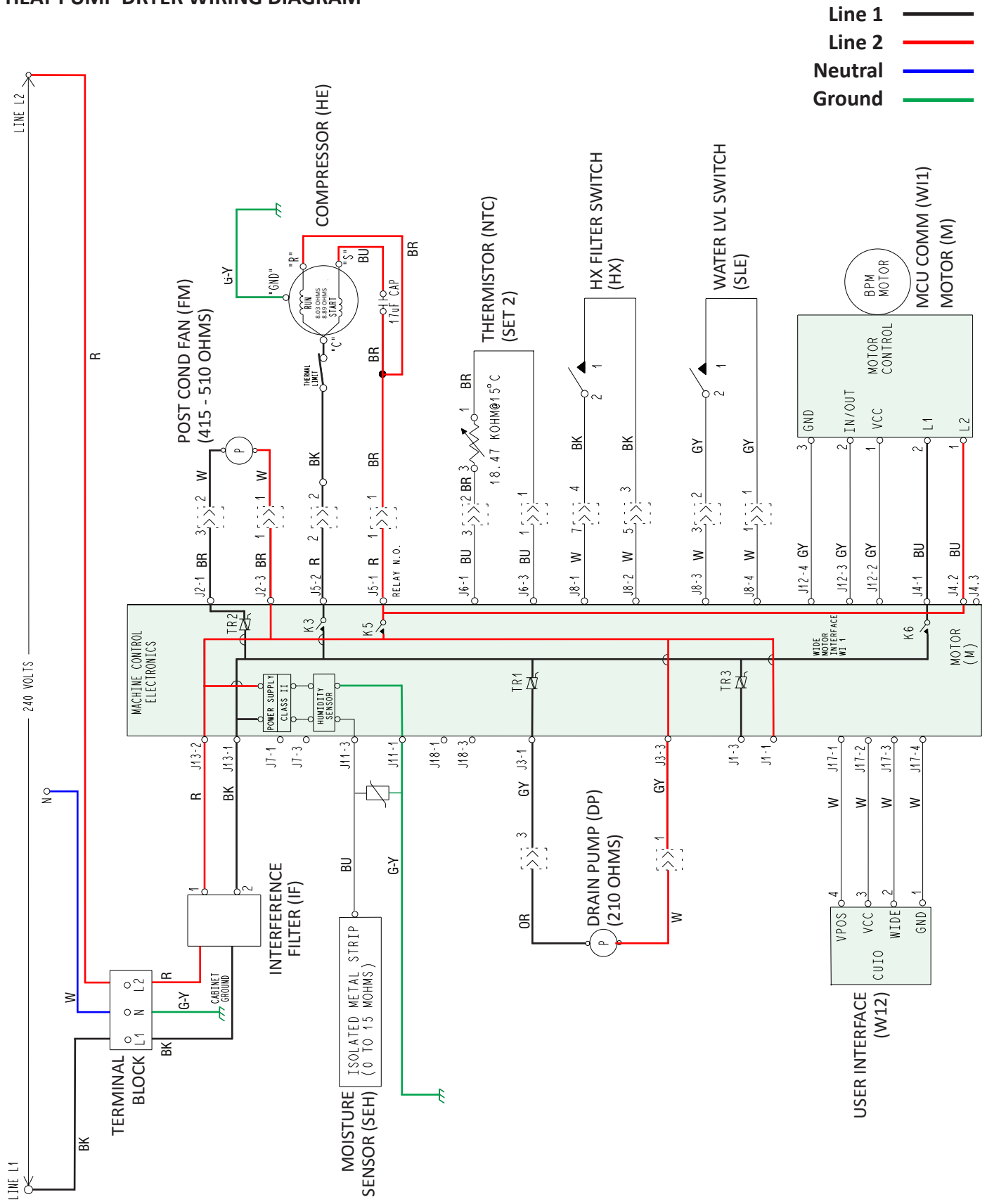

# For Service Technician Use Only

**⚠ DANGER**



### Electrical Shock Hazard

**Only authorized technicians should perform diagnostic voltage measurements.**

**After performing voltage measurements, disconnect power before servicing.**

**Failure to follow these instructions can result in death or electrical shock.**

## Component Testing

### TESTING WASHER COMPONENTS FROM THE CONTROL

Before testing any of the components, perform the following checks:

- The most common cause for mis-diagnosed control failure is poor connections. Therefore, disconnecting, inspecting and reconnecting wires will be necessary throughout test procedures.
- All tests/checks should be made with a VOM or DVM having a sensitivity of 20,000 ohms-per-volt DC, or greater.
- Check all connections before replacing components, looking for broken or loose wires, failed terminals, or wires not pressed into connectors far enough.
- **IMPORTANT:** Voltage checks must be made with all connectors attached to the boards.
- Resistance checks must be made with power cord unplugged or power disconnected, and with wiring harness or connectors disconnected from the control.

The testing procedures in this section may require the use of needle probes to measure voltage. Failure to use needle probes may damage the connectors.

## TEST #1: ACU Power Check

This test is used to determine if power is present at the machine control electronics. This test assumes that proper voltage is present at the outlet.

1. Unplug dryer or disconnect power.
2. Check for appropriate line voltages at the outlet: 240 VAC (electric 2-phase) or 208 VAC (electric 3-phase).
  - If line voltage is present, go to step 3.
  - If line voltage is not present, check for tripped circuit breaker or blown household fuse. If CB (circuit breaker) is not tripped, have customer check with qualified electrician.
3. Remove top panel, left side panel, and console to access the machine electronics.
4. **ACU VAC** – With voltmeter set to **AC**, connect black probe to ACU J13-2 (L2) and red probe to J13-1 (L1). (See Figure 2.) Plug in dryer or reconnect power.
  - If 240 VAC is present, unplug dryer or disconnect power and go to step 5.
  - If 240 VAC is not present, unplug dryer or disconnect power and perform TEST #2: Supply Connections, page 13.
5. **ACU +5 VDC** – With voltmeter set to **DC**, unplug connector **J17** from the ACU and connect black probe to ACU J17-4 (ground) and red probe to J17-2 (+5 VDC). Plug in dryer or reconnect power.
  - If +5 VDC is present, unplug dryer or disconnect power and go to step 8.
  - If +5 VDC is not present, go to step 6.
6. Unplug dryer or disconnect power. Unplug **J7** and **J6** from the ACU. Plug in dryer or reconnect power and repeat step 5.
  - If +5 VDC returns, one of the thermistors has shorted. To diagnose thermistors, see TEST #4c, page 17.
  - If +5 VDC is not present, go to step 7.
7. Unplug dryer or disconnect power. Reconnect **J7** and **J6** to the ACU and unplug **J17** from the ACU. Plug in dryer or reconnect power and repeat step 5. Perform voltage check inside header J17 on ACU, between pins 2 & 4—**DO NOT SHORT PINS TOGETHER**.
  - If +5 VDC is still missing, unplug dryer or disconnect power and replace the ACU.
  - If +5 VDC returns, unplug dryer or disconnect power and check harnesses and connections between the ACU and user interface (UI). If acceptable, replace the UI.
8. **ACU +12 VDC** – with voltmeter set to **DC**, connect black probe to ACU J12-4 (ground) and red probe to J12-2 (+12 VDC). Plug in dryer or reconnect power.
  - If +12 VDC is present, go to step 9.
  - If +12 VDC is not present, unplug dryer or disconnect power and replace the ACU.
9. Unplug dryer or disconnect power.
10. Reassemble all parts and panels.
11. Perform the Service Test Cycle on pages 3 and 4 to verify repair.

## For Service Technician Use Only

APPLIANCE CONTROL UNIT (ACU) - FIGURE 1

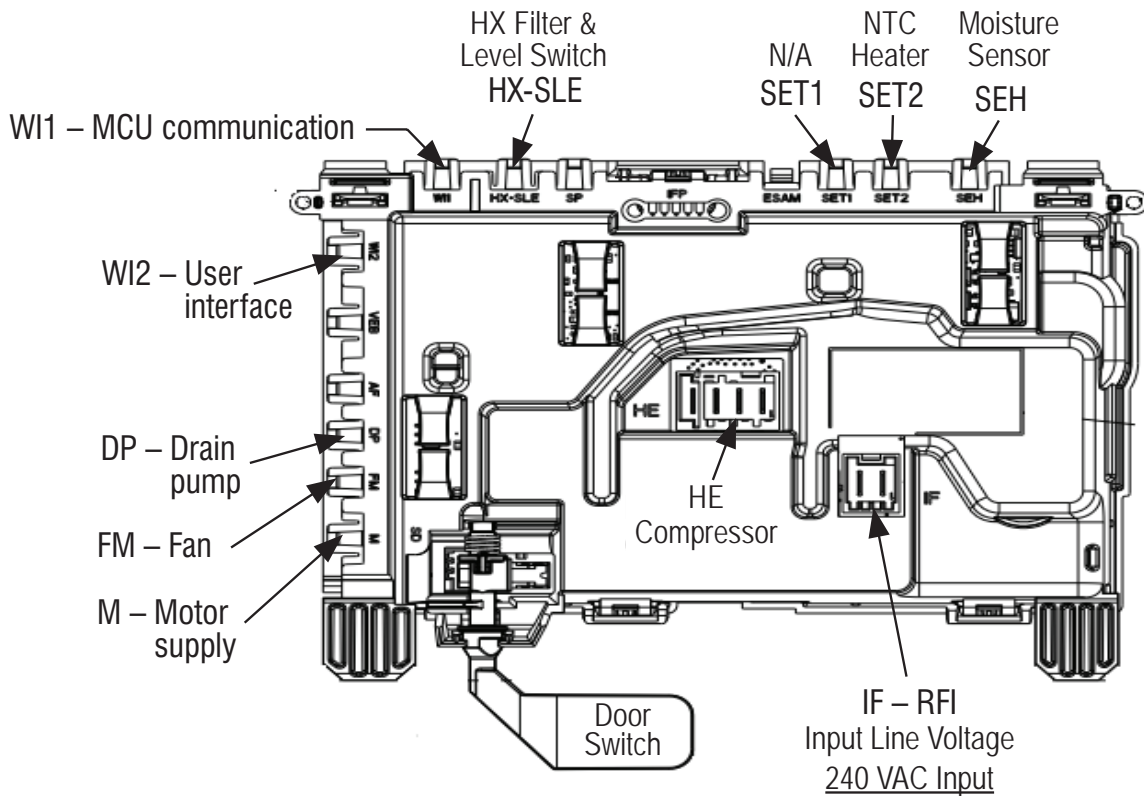

APPLIANCE CONTROL UNIT (ACU) PINOUTS - FIGURE 3

<b>IF – RFI</b>	<b>DP – Drain Pump</b>	<b>W12 – User Interface</b>	<b>HX-SLE – Heat Exchanger Filter and Level Switch</b>
J13-1 L1 In	J3-1 L1 Pump	J17-1 VPOS	J8-1 HX Filter Sw 1
J13-2 L2 In	J3-3 L2 Pump	J17-2 +5 VDC	J8-2 HX Filter Sw 2
		J17-3 WIDE	J8-3 Water Lvl Sw 1
		J17-4 GND	J8-4 Water Lvl Sw 2
<b>HE – Compressor</b>	<b>M – Motor Supply</b>	<b>SEH – Moisture Sensor</b>	<b>SET2 – NTC Heater</b>
J5-1 L2 Compressor	J4-1 L1 Motor	J11-1 GND	J6-1 NTC Heat 1
J5-2 L1 Compressor	J4-2 L2 Motor	J11-3 Moisture Sensor	J6-3 NTC Heat 2
<b>FM – Auxiliary Fan</b>	<b>W11 – MCU Communication</b>		
J2-1 L1 Fan	J12-2 +12 VDC		
J2-3 L2 Fan	J12-3 IN/OUT		
	J12-4 GND		

## For Service Technician Use Only

**⚠ WARNING**



**Electrical Shock Hazard**  
**Disconnect power before servicing.**  
**Replace all parts and panels before operating.**  
**Failure to do so can result in death or electrical shock.**

### TEST #2: Supply Connections (IF)

This test assumes that proper voltage is present at the outlet, and a visual inspection indicates that the power cord is securely fastened to the terminal block.

#### U.S. Installations:

1. Unplug dryer or disconnect power.
2. Remove the cover plate from the lower left corner of the back of the dryer. See figure 1.

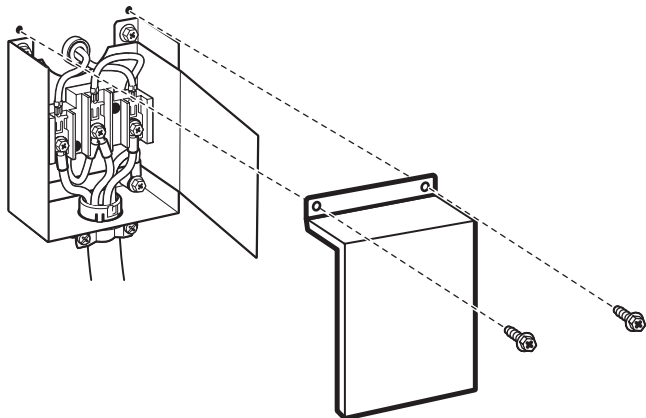

Figure 1

3. With an ohmmeter, check for continuity between the neutral (N) terminal of the plug and the center contact on the terminal block. See figure 2.
  - If there is no continuity, replace the power cord and test the dryer.
  - If there is continuity, go to step 4.

4. In a similar way, check which terminal of the plug is connected to the left-most contact on the terminal block and make a note of it. This will be L1 (black wire) in the wiring diagram. Follow the same procedure for L2 (red wire). See figure 2.

- When this is found, go to step 5.
- If neither of the plug terminals have continuity with the left-most contact of the terminal block, replace the power cord and retest dryer.

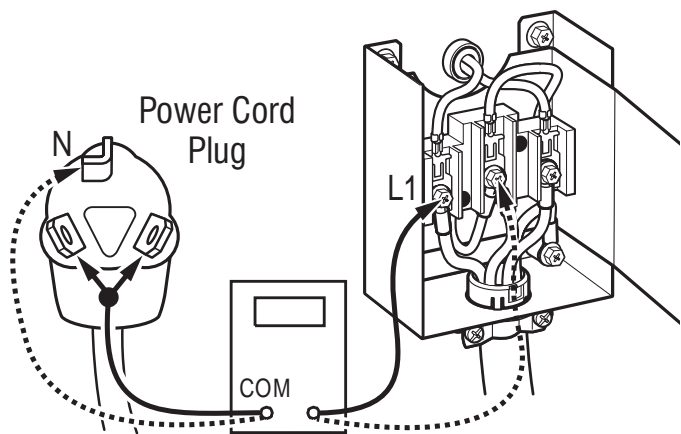

Figure 2

5. Remove the console to access the machine electronics without disconnecting any wiring to the ACU.
6. Check for continuity between the L1 (black) terminal of the plug and J13-1 on the ACU. See figure 3.
  - If there is continuity, go to step 7.
  - If there is no continuity, and the mechanical connections of the wire are secure, check for continuity at the IF – RFI. If there is no continuity, replace the harness between the ACU and the IF – RFI and the IF – RFI itself.
7. Check for continuity between the L2 (red) terminal of the plug and J13-2 on the ACU. See figure 3
  - If there is continuity, go to step 8.
  - If there is no continuity, and the mechanical connections of the wire are secure, check for continuity at the IF – RFI. If there is no continuity, replace the harness between the ACU and the IF – RFI and the IF – RFI itself.
8. Visually check that ALL connectors are fully inserted into the ACU.
9. Visually check that ALL connectors are fully inserted into the UI.
10. Reassemble all parts and panels.
11. Plug in dryer or reconnect power.
12. Perform the Service Test Cycle on pages 3 and 4 to verify repair.

# For Service Technician Use Only

## SUPPLY CONNECTIONS

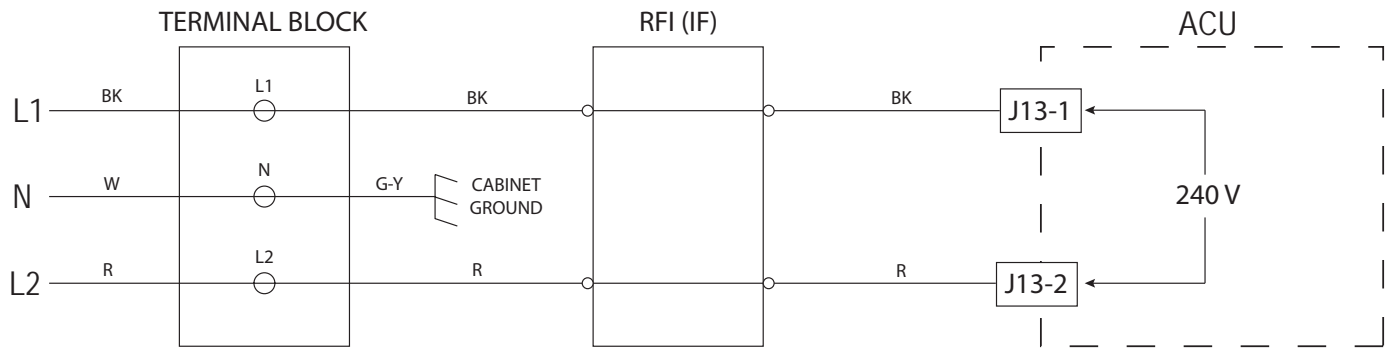

Figure 3 - Supply Connections Strip Circuit

### Canadian Installations:

1. Unplug dryer or disconnect power.
2. Access the machine electronics without disconnecting any wiring to the ACU.
3. With an ohmmeter, check the continuity from L1 and L2 plug terminals of the power cord to the terminals for L1 and L2 on the ACU. See figure 4.

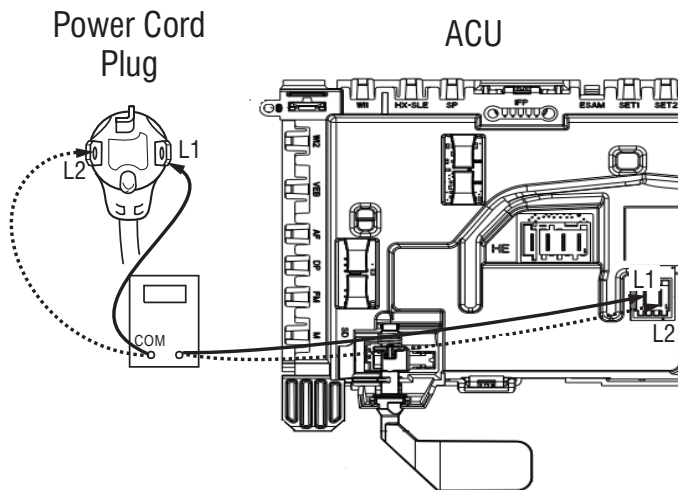



Figure 4

- If continuity exists for both connections, go to step 5.
  - If an open circuit is found, check the integrity of the connections of the power cord to the harness in the dryer; harness to the ACU; and the integrity of the power cord itself.
4. If it is necessary to replace the power cord, remove the retaining clip that secures the cord to the back panel. Disconnect the cord from the main harness and the ground wire from the rear panel, then pull out the power cord.
  5. Visually check that ALL connectors are fully inserted into the ACU.
  6. Visually check that ALL connectors are fully inserted into the UI.
  7. Reassemble all parts and panels.
  8. Plug in dryer or reconnect power.
  9. Perform the Service Test Cycle on pages 3 and 4 to verify repair.

## For Service Technician Use Only

**⚠ WARNING**



**Electrical Shock Hazard**

**Disconnect power before servicing.**

**Replace all parts and panels before operating.**

**Failure to do so can result in death or electrical shock.**

4. Check the wiring and components:
  - a. Check for loose, worn, or damaged drum belt—repair as necessary.
  - b. Verify that the spring and support structure is in position and in good condition.
  - c. Make sure there is no obstruction to drum movement. Check J12 and J4 connections on ACU to motor.
  - d. Check continuity. If there is no continuity, replace the wiring harness. If there is continuity, replace the drive motor.
5. If the preceding steps do not correct the problem, replace the ACU.
6. Reassemble all parts and panels.
7. Plug in dryer or reconnect power.
8. Perform the Service Test Cycle on pages 3 and 4 to verify repair.

### TEST #3 Motor Circuit (M)

This test will check the wiring to the motor and the motor itself. The following items are part of this motor system:

Part of Motor System	Heat Pump Dryer
Drum belt	✓
Door switch	✓
Harness/connection	✓
Drive motor	✓
Appliance Control Unit (ACU)	✓

**NOTE:** Verify motor movement in steps **S02** and **S03** of Service Test Cycle (page 4). If no motor movement, proceed with the following procedure.

1. Unplug dryer or disconnect power.
2. Remove top panel, left side panel, and console to access the machine electronics.
3. Door Switch problems can be uncovered by following procedure under TEST #7: Door Switch, page 20; however, the door switch is inside the ACU and no port is available.

### Motor Assembly

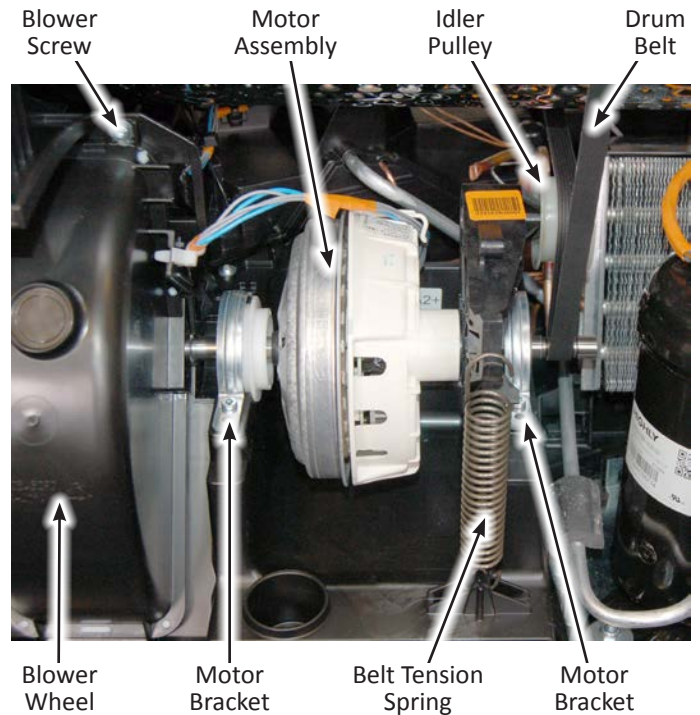

### MOTOR STRIP CIRCUIT

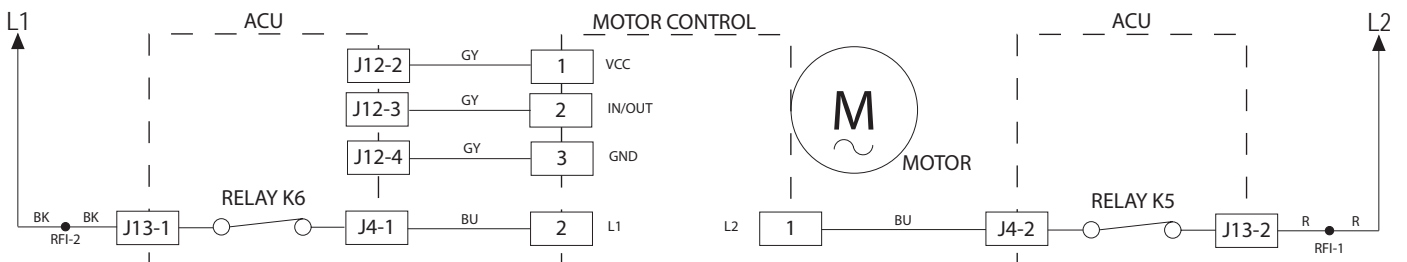



Figure 1 - Motor Strip Circuit

## For Service Technician Use Only

**⚠ DANGER**



**Electrical Shock Hazard**

**Only authorized technicians should perform diagnostic voltage measurements.**

**After performing voltage measurements, disconnect power before servicing.**

**Failure to follow these instructions can result in death or electrical shock.**

### TEST #4a: Heat Pump (HE)

**IMPORTANT:** The heat pump must be replaced as an assembly if any of the sealed system components malfunction. This includes the compressor, heat exchanger components (evaporator and condenser), the post condenser, expansion valve, and all tubings and fittings.

#### Heat pump does not heat—Process air flow:

1. Check both filters (primary lint filter and service filter) for restriction and clean as necessary.
2. If a significant amount of lint or debris is observed on the filter, remove the exchanger cover and vacuum the filter and any lint or debris from the fins and coils of the evaporator and condenser.

#### Heat pump does not heat—Compressor:

##### Compressor runs but cycles due to overheating

1. Check for restricted air flow caused by dirty filters or heat exchanger (see "Process air flow" above).
2. Auxiliary Fan – used to cool the post condenser and compressor electronics. Perform TEST #10: Auxiliary Fan, page 21, to verify the operation of the auxiliary (post condenser) fan.

##### Compressor does not start/humming noise:

- ✓ **Quick Check:** Perform TEST #1: ACU Power Check, page 12, and the Service Test Cycle on pages 3 and 4 to test for L1 and L2 line voltage.
    - If L1 and L2 are present, go to step 1.
    - If L1 and L2 are not present, go to TEST #2: Supply Connections, page 13.
1. Unplug dryer or disconnect power.
  2. Remove top panel and right side panel to access the compressor/heat pump assembly.
  3. Visually check the connections between the compressor and run capacitor.
  4. If the connections look good, check the capacitor for leaks, corrosion, bulging of the metal canister, or any other physical signs that the capacitor should be replaced.

### TEST #4: Heating System (Compressor)

This test is performed when either of the following situations occurs:

- ✓ Heat pump does not heat—Process air flow
- ✓ Heat pump does not heat—Compressor
- ✓ Compressor does not start/humming noise

This test checks the components making up the heating circuit. The following items are part of this system:

Part of Heater System	Heat Pump Dryer
Harness/connection	✓
Compressor relay	✓
Heat pump assembly	✓
Compressor thermistor	✓
Appliance Control Unit (ACU)	✓

### HEAT PUMP (COMPRESSOR) STRIP CIRCUIT

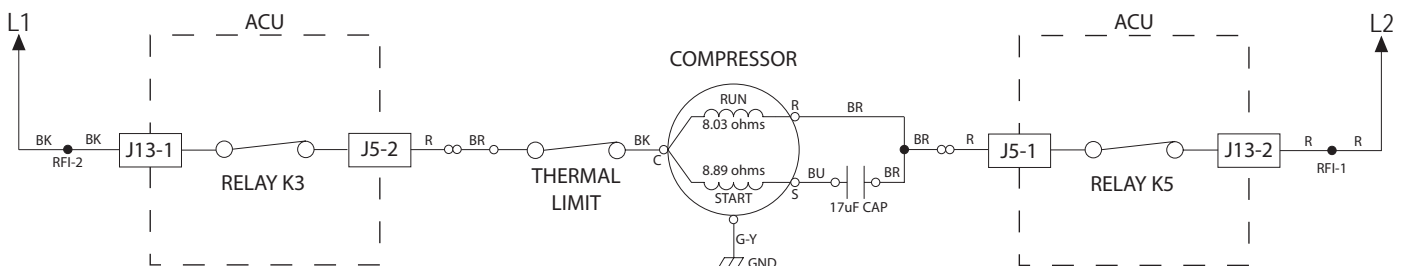

Figure 1 - Compressor Strip Circuit

## For Service Technician Use Only

5. Test the compressor run capacitor.
  - a. Discharge the capacitor by touching the leads of a 20,000 Ω resistor to the two terminals.
  - b. Disconnect the wires from the capacitor terminals.
  - c. **ANALOG METER** - Set your meter to ohms (resistance) function, range to R x 10,000, or the highest scale on the meter. Touch the meter leads to the capacitor terminals. The meter should indicate nearly a short circuit initially, then a steady increase in resistance should be noted. The needle will move more slowly as it creeps up. If your capacitor has a resistance of at least 100K (100,000 ohms) it is good.

If the needle doesn't move when you connect the leads to the capacitor, the capacitor is open. If the needle indicates a short initially and stays there, the capacitor is shorted. Replace the capacitor.

**DIGITAL METER** - If you have a digital multi-meter with an autoranging function, set the meter to the ohms (resistance) function. Pay attention to the resistance units displayed on the meter readout. No units = ohms. "K" = the readout value times 1,000 ohms. "M" = the readout value times 1,000,000 ohms.

Proceed as described with the analog meter for the test. What you're looking for is a low initial resistance which climbs steadily until it exceeds 100,000 ohms. If the value is below 100,000 ohms (100K) but above 10,000 ohms (10K), the capacitor is weak and should be replaced.

6. If the preceding steps did not correct the compressor problem, proceed to the next section, "Compressor does not run".

### Compressor does not run:

- ✓ **Quick Check:** Perform the Service Test Cycle on pages 3 and 4 to test for L1 and L2 line voltage.
    - If L1 and L2 are present, go to step 1.
    - If L1 and L2 are not present, go to TEST #2: Supply Connections, page 13.
1. Unplug dryer or disconnect power.
  2. Remove top panel, left side panel, and console to access the machine electronics.
  3. Check compressor wiring—use an ohmmeter to measure the resistance at the wire terminal on the compressor relay (K5) and L2 at the terminal block.
    - If the resistance is 2–15 Ω, go to step 10.
    - If an open circuit is detected, go to step 4.
  4. Remove the belt and drum to access the compressor/heat pump assembly.
  5. Visually check the connections between the compressor relay and the compressor components, and the compressor components and the L2 terminal.
  6. If the connections look good, check for continuity between the wire terminal on the compressor relay (K3) and terminal "C" (common) on the compressor.
    - If there is continuity, go to step 8.
    - If there is no continuity, go to step 7.
  7. Remove the compressor cover and check for continuity across the thermo-switch on the compressor.
    - If there is continuity, go to step 8.

- If there is no continuity, replace the thermo-switch.
8. Remove the compressor cover and remove all three motor wires: Common (C)=Black, Run (R)=Red, and Start (S)=Yellow.
  9. Using the following chart, check the resistance values of the compressor Run and Start winding coils.
 

**NOTE:** Run and Start winding coils must be checked at the compressor.

Winding	Resistance in ohms	Contact Points of Measurements
RUN	8.03 ± 10%	Compressor terminal "C" to terminal "R"
START	8.89 ± 10%	Compressor terminal "C" to terminal "S"
START & RUN	16.92 ± 10%	Compressor terminal "R" to terminal "S"

- If the resistance at the compressor is correct, go to step 10.
- If the Run or Start winding resistance is much greater or less than the values listed in the chart, replace the heat pump base assembly.

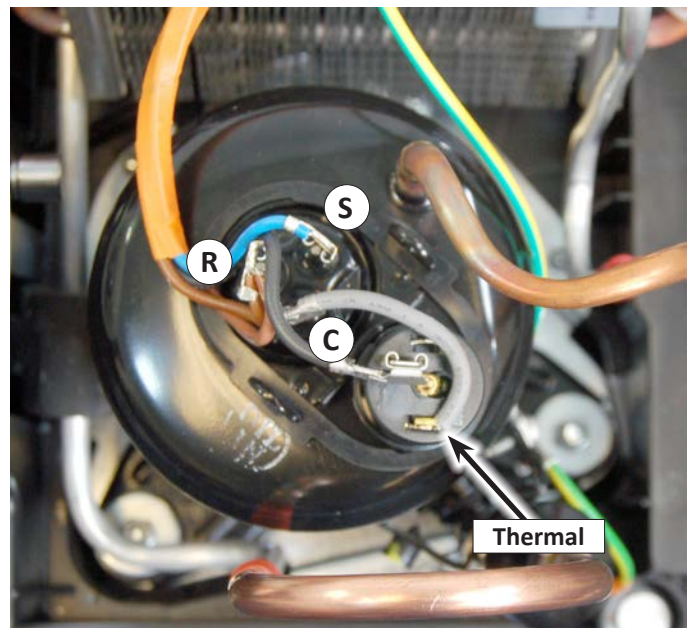

Figure 2 - Compressor Diagram

10. If the preceding steps did not correct the problem and L1 and L2 were both detected during the Quick Check, replace the ACU.
11. Reassemble all parts and panels.
12. Plug in dryer or reconnect power.
13. Perform the Service Test Cycle on pages 3 and 4 to verify repair.

## For Service Technician Use Only

**⚠ WARNING**



**Electrical Shock Hazard**  
 Disconnect power before servicing.  
 Replace all parts and panels before operating.  
 Failure to do so can result in death or electrical shock.

connector. The following table gives temperatures and their associated resistance values.

**NOTE:** All thermistor resistance measurements must be made while dryer is unplugged and connector removed from ACU.

- If the resistance is OK, the compressor thermistor is good. Proceed to step 4.
- If the thermistor resistance does not agree with the table, replace the compressor thermistor.

COMPRESSOR THERMISTOR RESISTANCE (Heat Pump Dryer)		
TEMPERATURE °F (°C)	RESISTANCE k ohms	RESISTANCE Tolerance (%)
32° (0°)	35.975	± 5.8
86° (30°)	9.786	± 3.7
104° (40°)	6.653	± 3.1
122° (50°)	4.608	± 2.6
140° (60°)	3.243	± 2.0
158° (70°)	2.332	± 2.5
203° (95°)	1.093	± 3.7

### TEST #4c Thermistor (SET2)

#### Compressor Thermistor (NTC SYSTEM)

**NOTE:** Begin with an empty dryer at ambient temperature and a clean lint screen.

1. Unplug dryer or disconnect power.
2. Remove top panel, left side panel, and console to access the machine electronics.
3. Remove connector J6 (HP dryer) from the ACU and measure the resistance between J6-1 and J6-3 at the
4. Check J6-1 and J6-3 to dryer cabinet ground. If either pin indicates continuity to ground (short), replace wiring harness; otherwise, proceed to step 5.
5. If the preceding steps did not correct the problem, replace the ACU.

#### CONNECTOR LOCATION (ACU TOP)

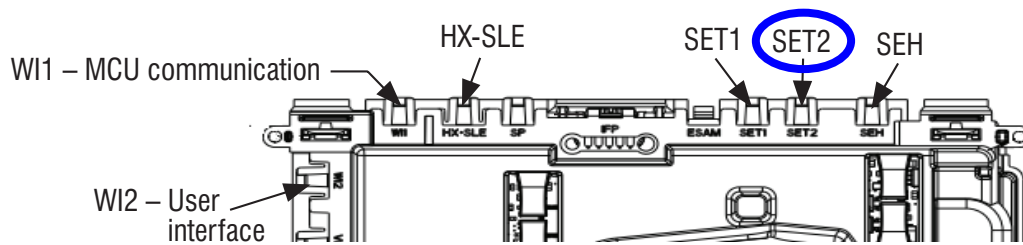

Figure 1 - Thermistor Connector (SET2)

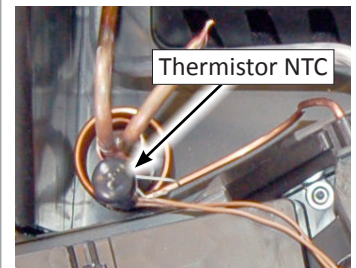

Figure 2 - Thermistor

#### THERMISTOR (NTC)

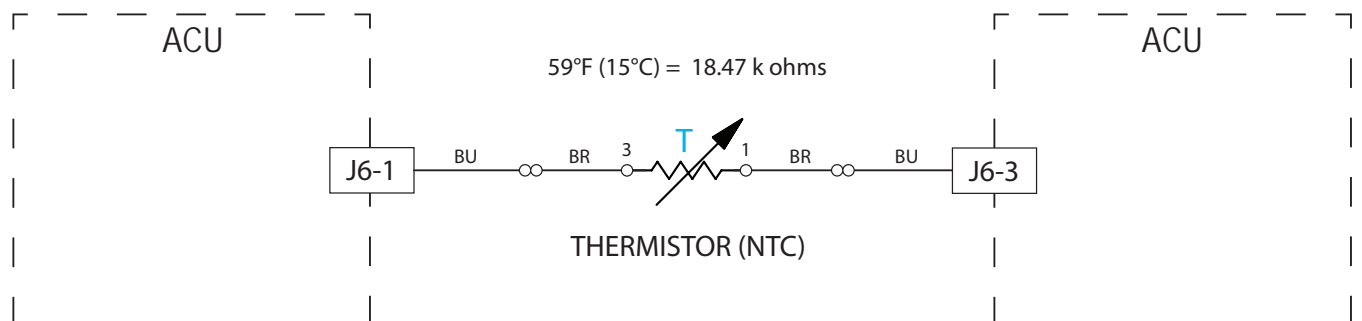



Figure 3 - Thermistor Strip Circuit

## For Service Technician Use Only

⚠ **WARNING**



**Electrical Shock Hazard**

**Disconnect power before servicing.**

**Replace all parts and panels before operating.**

**Failure to do so can result in death or electrical shock.**

**NOTE:** Refer to strip circuit below to diagnose moisture sensor.

1. Unplug dryer or disconnect power.
2. Remove top panel, left side panel, and console to access the machine electronics.
3. Access moisture sensor inside front of drum to verify continuity between moisture sensor in drum and J11-3 (blue wire) pin on ACU. **NOTE:** You may need to clean sensor strip in drum before testing.
  - Verify continuity between J11-1 (green wire) pin on ACU and ground screw on cabinet.
  - Verify continuity across J11-1 and J11-3 connectors.
  - If continuity is found in the steps above, proceed to step 5. If no continuity, proceed to step 4.
4. Remove front panel and check J11-3 wire connection to moisture sensor in drum (connector is located below the door opening between the front panel and bulkhead) and J11-1 wire connection to cabinet. If still no continuity, replace the main harness.
5. Reassemble all parts and panels.
6. Plug in dryer or reconnect power.
7. Run the moisture sensor diagnostic test (Service Test Cycle step S04; see pages 3 and 4). If the moisture sensor diagnostic test passes (no F03 error code), check the outlet thermistor: see TEST #4c, page 17.
  - If the problem persists after replacing the moisture sensor and thermistor, consider adjusting the dryness level (see TEST #5a: Adjusting Customer-Focused Dryness Level).
8. If the preceding steps did not correct the problem, replace the ACU.

### TEST #5: Moisture Sensor (SEH)

This test is performed when an automatic cycle stops too soon, or runs much longer than expected.

**NOTE:** Dryer will shut down automatically after 4 hours and 10 minutes.

The following items are part of this system:

Part of Moisture System	Heat Pump Dryer
Harness/connection	✓
Metal sensor strips	✓
Appliance Control Unit (ACU)	✓

### CONNECTOR LOCATION (ACU TOP)

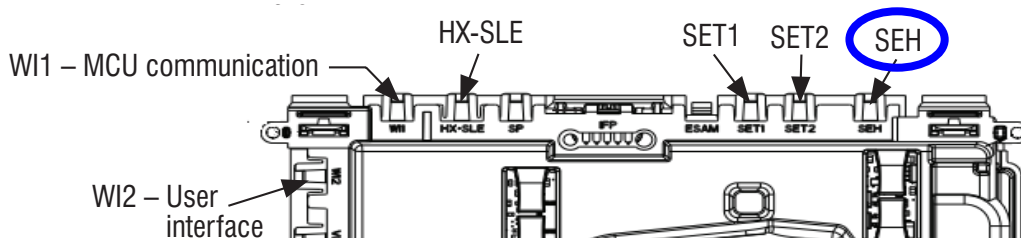

Figure 1 - Moisture Sensor Connector (SEH)

### MOISTURE (HUMIDITY) SENSOR STRIP CIRCUIT

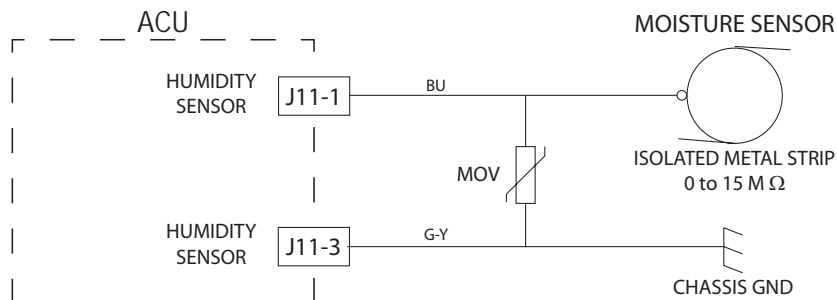

Figure 2 - Moisture Sensor Strip Circuit

## For Service Technician Use Only

**⚠ WARNING**

**Electrical Shock Hazard**  
**Disconnect power before servicing.**  
**Replace all parts and panels before operating.**  
**Failure to do so can result in death or electrical shock.**

**TEST #5a: Adjusting Customer-Focused Dryness Level**

**NOTE:** If the customer complains about the clothes being less dry or more dry than desired and the moisture sensor passes TEST #5: Moisture Sensor, step 2, the total dry time can be lengthened or shortened by changing the Customer-Focused Dryness Level from “3” (factory default) to a “2” (15% less drying time), “1” (30% less drying time), “4” (15% more drying time), or “5” (30% more drying time) auto cycle.

1. Press **POWER**, then press and hold the **PROGRAM** button as the dryer counts down “3-2-1” before displaying the current dryness level setting on the 7-segment display. The factory default value is “3”.
2. Turning the cycle selector knob counterclockwise reduces the dryness level setting number. Turning the cycle selector knob clockwise increases the dryness level setting number. The new setting is displayed in the 7-segment display.
3. With the display showing the desired dryness level setting, press the cycle selector knob to save the setting and exit to standby mode. The result will be stored in EEPROM of the ACU and will be retained after a power loss.

**NOTE:** If a button other than the cycle selector knob is pressed, the dryness setting is reverted back to its previous setting.

4. Press the **POWER** button at any time to exit from this mode.

## For Service Technician Use Only

⚠ **WARNING**



**Electrical Shock Hazard**

**Disconnect power before servicing.**

**Replace all parts and panels before operating.**

**Failure to do so can result in death or electrical shock.**

### TEST #6: Buttons and Indicators

This test is performed when any of the following situations occurs during step **S01** of the Service Test Cycle (see page X).

- ✓ **None of the indicators or display turn on**
- ✓ **Some buttons do not light**
- ✓ **No beep sound is heard**

#### None of the indicators or display turn on:

1. Unplug dryer or disconnect power.
2. Remove top panel, left side panel, and console to access the ACU and user interface (UI).
3. Visually check that ACU connectors are inserted all the way into the ACU.
4. Visually check that UI connector is inserted all the way into the UI. Check for continuity in the UI harness. If there is no continuity, replace the harness.
5. Visually check that the UI and housing assembly is properly inserted into the front console.

6. If all visual checks pass, perform TEST #1: ACU Power Check, page 12, to verify supply voltages.
  - If supply voltages are present, replace the user interface and housing assembly.
  - If supply voltages are not present, replace the ACU.
7. Reassemble all parts and panels.
8. Plug in dryer or reconnect power.
9. Perform step S01 of the Service Test Cycle on page 3 to verify repair. If it does not pass the test, replace the UI.

#### Some buttons do not light:

1. Unplug dryer or disconnect power.
2. Remove top panel, left side panel, and console to access the ACU and user interface (UI).
3. Visually check that the UI and housing assembly is properly inserted into the front console.
4. If visual check passes, replace the UI and housing assembly.
5. Reassemble all parts and panels.
6. Plug in dryer or reconnect power.
7. Perform step **S01** of the Service Test Cycle on page 3 to verify repair. If it does not pass the test, replace the UI.

#### No beep sound is heard:

1. Unplug dryer or disconnect power.
2. Remove top panel, left side panel, and console to access the ACU and user interface (UI).
3. Visually check that ACU connectors are inserted all the way into the ACU.
4. Visually check that UI connector is inserted all the way into the UI.
5. If all visual checks pass, replace the UI and housing assembly.
6. Reassemble all parts and panels.
7. Plug in dryer or reconnect power.
8. Perform step **S01** of the Service Test Cycle on page 3 to verify repair. If it does not pass the test, replace the UI.

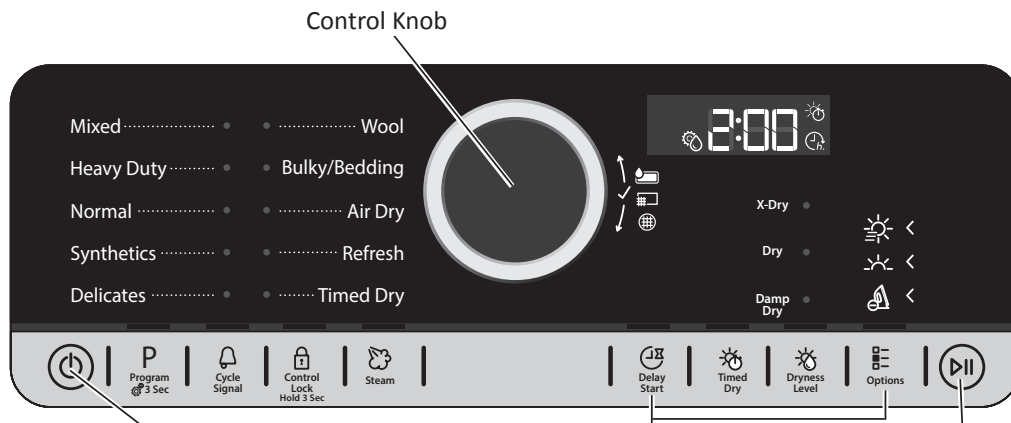

POWER button: press and hold until display turns on.

DELAY WASH and OPTIONS buttons: press DELAY START and OPTIONS buttons together to enter Service Diagnostic Mode/Service Test Cycle.

START/PAUSE button: press and hold to run Service Test Cycle and advance through steps in Service Test Cycle.

Figure 1- Service Diagnostic Mode/Test Cycle

## For Service Technician Use Only

**⚠ WARNING**



**Electrical Shock Hazard**

**Disconnect power before servicing.**

**Replace all parts and panels before operating.**

**Failure to do so can result in death or electrical shock.**

2. Remove top panel, left side panel, and console to access the machine electronics.
3. Check the ACU and door assembly:
  - a. Verify that the ACU is fully engaged with the front panel (upper clips hooked to the ACU and ACU feet are inside front panel slots).
  - b. Verify that there are no obstructions between the white lever on the ACU and the door.
  - c. Verify that the door assembly is aligned with the door latch.
  - d. Verify that there is physical contact of the door with the white lever on the ACU when the door is closed.
- If there was a problem with any of the above, go to step 4. If the visual checks above are OK, reassemble all parts and panels.
4. Remove the ACU and visually inspect the white lever:
  - a. Verify that the white lever and switch are not broken or damaged.
  - b. Verify that the ACU enclosure is closed, the spring is present and in place, and the white lever is in place.
  - c. Check the functionality of the door switch by attempting to activate it by pressing the white lever on the ACU.
- Replace any damaged or missing parts. If the door switch could not be activated in step c, replace the ACU.
5. Reassemble all parts and panels.
6. Plug in dryer or reconnect power.
7. Perform the Service Test Cycle on pages 3 and 4 to verify repair. If the failure persists, replace the ACU.

### TEST #7: Door Switch (ACU)

Attempt to perform Service Test Cycle on pages 3 and 4. If the routine is unable to start, the dryer is detecting an open door. Open and close the door again. If Service Test Cycle still will not start, try to start a dryer cycle. If pressing START produces an invalid sound and the START light blinks, the dryer is detecting an open door. If dryer runs with the door open during the Service Test Cycle or when running a dryer cycle, there is a short in the circuit.

If any of the preceding conditions are true:

1. Unplug dryer or disconnect power.

### DOOR SWITCH/ACU

Figure 1- Door Switch Location

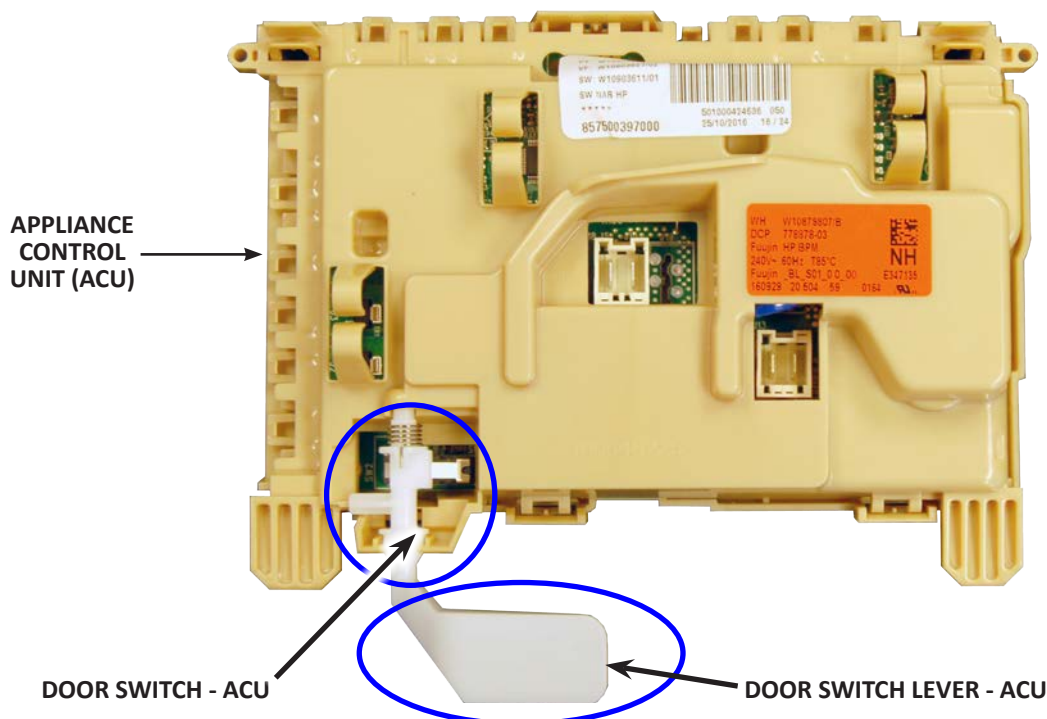

## For Service Technician Use Only

**⚠ DANGER**



**Electrical Shock Hazard**

**Only authorized technicians should perform diagnostic voltage measurements.**

**After performing voltage measurements, disconnect power before servicing.**

**Failure to follow these instructions can result in death or electrical shock.**

6. Verify AC voltage according to Test #1: ACU Power Check, page 12.
7. Access the drain system cover by removing the left side panel and the pump cover; verify that the drain hose connections are OK, and that the drain harness (line to line connection) and float harness (line to line connection) are connected to the drain system. Check the continuity of the harness. If there are connectivity and continuity issues, replace the harness and verify that the “water tank full” indicator is off and that the pump is active in Service Test Cycle step S04.
8. If everything is connected and the drain pump still does not drain water from the sump, measure the resistance across pins 1 and 3; the resistance should be approximately 210 Ω. If the reading is infinite (open), replace the drain pump.
9. If the preceding steps did not correct the problem, replace the ACU.

### TEST #8: Drain Pump (DP)

This test is performed when “water tank full” indicator is displayed and never turns off (no error code is displayed). The float switch is in full position.

The following items are part of this system:

Part of Drain System	Heat Pump Dryer
Harness/connection	✓
Drain pump	✓
Water level switch	✓
Appliance Control Unit (ACU)	✓

1. If there is water beneath the front of the dryer, verify that the dryer is level and that the drain hose is securely fastened to the drain port.
2. Verify that the drain hose (bottom center of back of dryer) is not pinched, kinked, plugged, or otherwise restricted.
3. Unplug dryer or disconnect power.
4. Remove top panel, left side panel, and console to access the machine electronics.
5. Verify visually that ACU connections J3-1 and J3-3 are connected properly.

### Theory of Operation

#### Drain Pump Operation

During the drying cycle, the drain pump runs 32 seconds ON and 180 seconds (3 minutes) OFF. This process runs continuously throughout the drying cycle to prevent water from reaching a high level in the sump.

#### Float Switch Operation

If the water level switch detects a high level of water in the sump (float switch in full position), the pump will be activated one last time for 3 minutes. If the water level switch does not change state, the dryer will stop and the “water tank full” indicator is displayed.

#### SWITCH LEVELS

Full Position—Switch is OPEN

Empty Position—Switch is CLOSED

#### CONNECTOR LOCATION (Drain Pump)

See Connector Diagram Figure 1, on page 3-17.

### DRAIN PUMP / WATER LEVEL SWITCH STRIP CIRCUIT

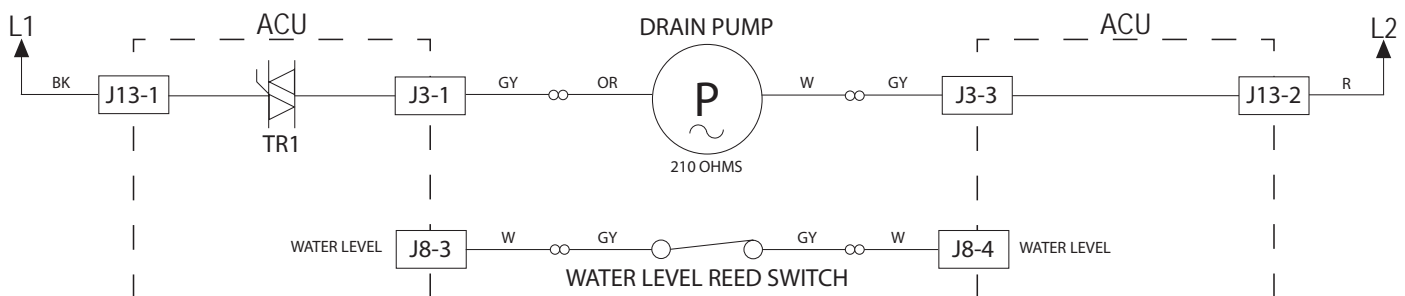



Figure 2 - Drain Pump / Water Level Switch Strip Circuit

## For Service Technician Use Only

⚠ DANGER



**Electrical Shock Hazard**

**Only authorized technicians should perform diagnostic voltage measurements.**

**After performing voltage measurements, disconnect power before servicing.**

**Failure to follow these instructions can result in death or electrical shock.**

### TEST #9: Water Level Switch (SLE)

1. Verify visually that ACU connections J8-3 and J8-4 are connected properly.
2. Verify 5 VDC voltage according to Test #1: ACU Power Check, page 12.
3. Access the drain system cover by removing the left side panel and the pump cover; verify if the float harness (line to line connection) is connected. Check continuity in the harness. If there are connectivity and continuity issues, replace the harness and verify if the “water tank full” indicator is off 60 seconds after pump activation (if there is water inside) in Service Test Cycle step S04.
4. If the harness is OK, check water level switch status by verifying the continuity in the terminals of the water level switch connector. Tank full = switch open, tank empty = switch closed. Fill the water tank manually to check the switch status.

- If state does not change, replace the water level switch. **NOTE:** harness, water level switch, and reed switch come together.
- If replacement of the water level switch does not solve the problem, replace the ACU.

#### CONNECTOR LOCATION (Water Level Switch & Pump)

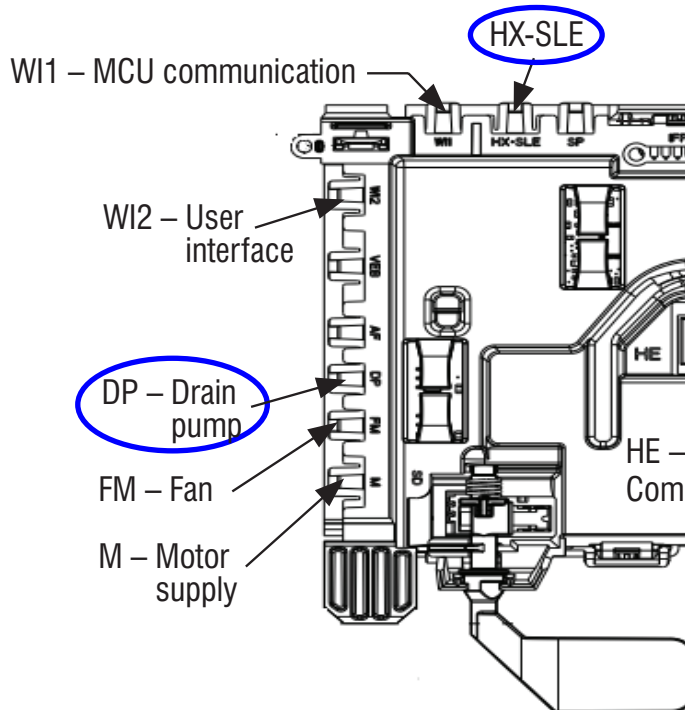

Figure 1- Drain Pump (DP) & Water Level Switch Connectors (SLE)

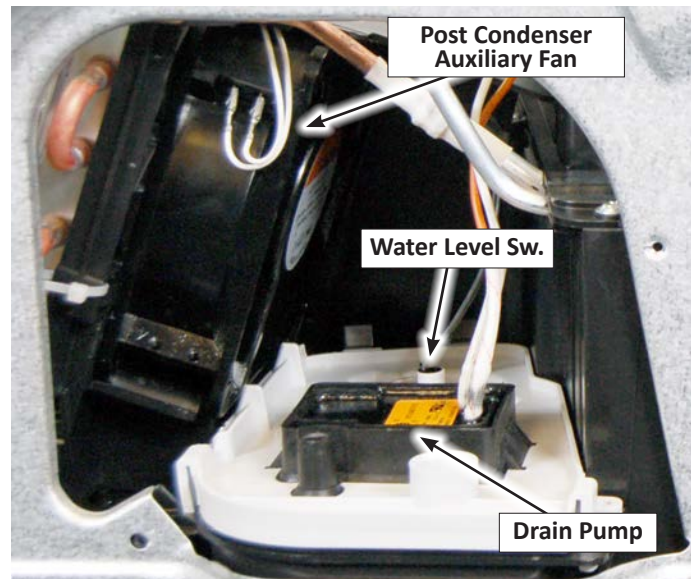

Figure 2- Drain Pump, Level Switch and Fan Access

#### DRAIN PUMP / WATER LEVEL SWITCH STRIP CIRCUIT

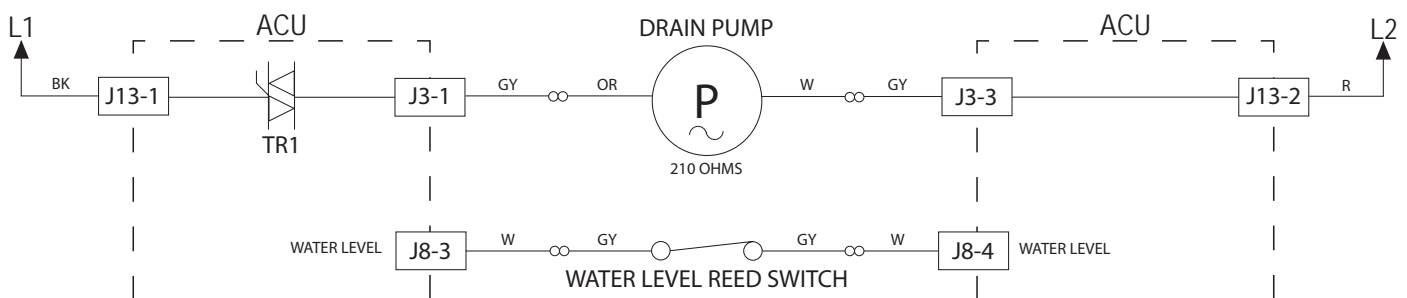



Figure 3 - Drain Pump / Water Level Switch Strip Circuit

## For Service Technician Use Only

**⚠ DANGER**



**Electrical Shock Hazard**

**Only authorized technicians should perform diagnostic voltage measurements.**

**After performing voltage measurements, disconnect power before servicing.**

**Failure to follow these instructions can result in death or electrical shock.**

### TEST #10: Fan, Post Condenser (FM)

This test is performed when the fan for the post condenser is not spinning.

**NOTE:** To test the post condenser fan, plug in dryer or reconnect power. Press **POWER**, select Timed Dry, and press **START**. The fan should start running.

The following items are part of this system:

Part of Post Condenser Fan System	Heat Pump Dryer
Harness/connection	✓
Post Condenser Fan	✓
Appliance Control Unit (ACU)	✓

1. Unplug dryer or disconnect power.
2. Remove the fan grille on the back panel to access the fan. Verify that the grille and fan blades are free from obstructions and that the fan can spin.
3. Remove top panel, left side panel, and console to access the machine electronics.
4. Visually check that the J2 connector is inserted all the way into the ACU.
  - If visual check passes, go to step 5.
  - If connector is not inserted properly, reconnect J2 and retest.

5. Remove connector J2 from the ACU. With an ohmmeter, measure the resistance across pins 1 and 3.
6. Resistance should be approximately 464 Ω ±10%.
  - If the reading is infinite (open), go to step 7.
  - If the reading is correct, go to step 11.
7. Remove the rear panel to access the post condenser fan.
8. Visually check that the in-line fan connector is securely connected.
  - If visual check passes, go to step 9.
  - If connections are loose, reconnect the in-line fan connector and retest.
9. With an ohmmeter, check the harness for continuity between the fan and the ACU J2-1 and J2-3 connector.
  - If there is continuity, go to step 10.
  - If there is no continuity, repair or replace the upper dryer harness and retest.
10. With an ohmmeter, measure the resistance across the two fan connector terminals. Resistance should be approximately 464 Ω ±10%.
  - If the reading is infinite (open), replace the fan and retest.
  - If the reading is correct, go to step 11.
11. With a voltmeter set to AC, connect the black probe to ACU J13-1 (L1) and the red probe to J13-2 (L2). Plug in dryer or reconnect power.
  - If 240 VAC is present, unplug dryer or disconnect power and go to step 12.
  - If 240 VAC is not present, unplug dryer or disconnect power and perform TEST #2: Supply Connections, page 13.
12. With a voltmeter set to AC, follow Test #1: ACU Power Check, page 12, AC and 5V verification.
  - If 240 VAC is present, go to step 13.
  - If 240 VAC is not present, go to step 13.
13. If the preceding steps did not correct the post condenser fan problems, replace the ACU.
  - Unplug dryer or disconnect power.
  - Replace the ACU.
  - Reassemble all parts and panels.
  - Retest fan operation.

### FAN STRIP CIRCUIT

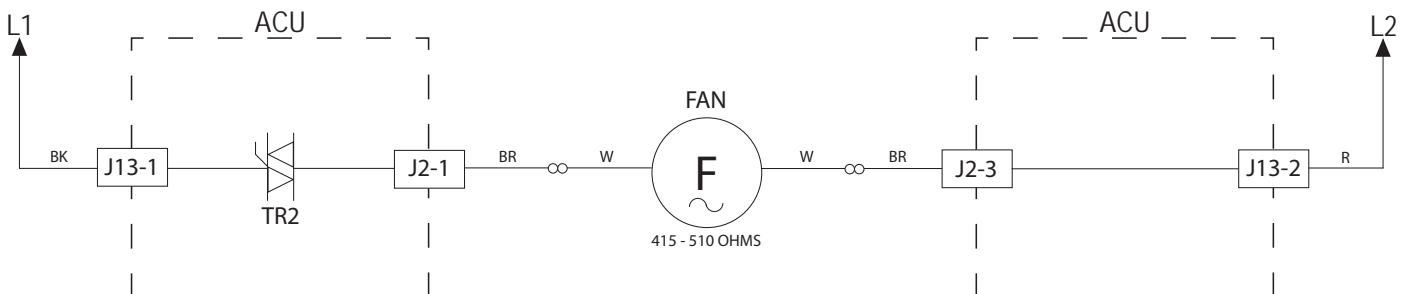



Figure 1 - Fan Strip Circuit

## For Service Technician Use Only

**⚠ WARNING**



**Electrical Shock Hazard**  
**Disconnect power before servicing.**  
**Replace all parts and panels before operating.**  
**Failure to do so can result in death or electrical shock.**

### TEST #11 Heater Exchanger (HX) Filter Switch

This is a test to perform when the icon “Bottom filter is blocked” lights and does not allow the start of a cycle.

1. Open the cover to access the bottom filter.
2. Verify that the release levers are in place and in good condition to hold the bottom filter in place.
3. Remove the filter and make sure that it is not blocked by lint.
4. Put the filter back in place and make sure that the release levers are securely holding it.
5. If the icon is still lit, remove the top panel and console to access the machine electronics. Remove the left side panel to access the reed switch.
6. Verify continuity between J8-1 and J8-2: when the filter is removed, there should be high resistance (open contact); when the filter is in place, there should be low resistance (closed contact). If not, replace the harness.

**NOTE:** The harness includes the reed switch and the water level switch.

7. If the failure persists after replacing the harness, replace the ACU.

### CONNECTOR LOCATION (ACU TOP)

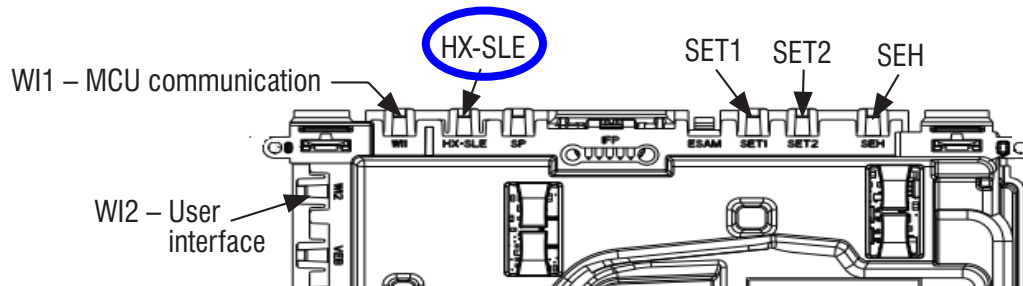

Figure 1 - Heater Exchange Filter Switch Connector (HX)

### HEATER EXCHANGE FILTER SWITCH STRIP CIRCUIT

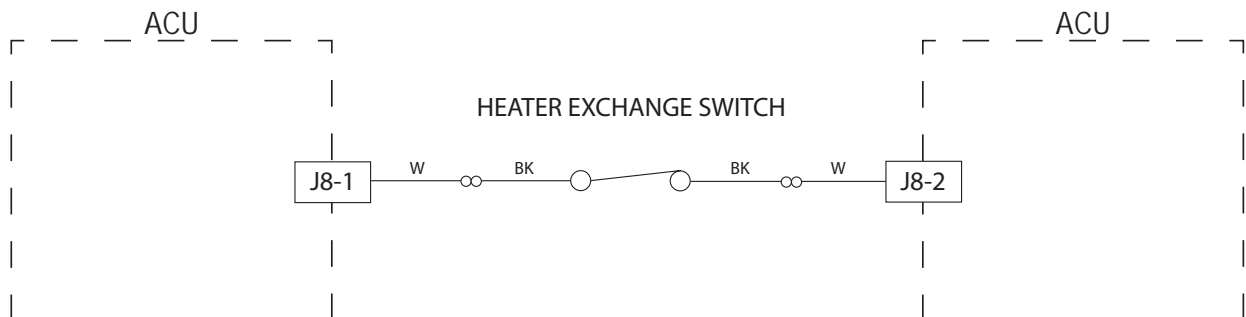



Figure 2 - Heater Exchange Switch Strip Circuit

## For Service Technician Use Only

**⚠ WARNING**



**Electrical Shock Hazard**  
**Disconnect power before servicing.**  
**Replace all parts and panels before operating.**  
**Failure to do so can result in death or electrical shock.**

### TEST #12: Communications Between UI and ACU (W12)

This is a test to perform when the UI turns on and the button LEDs flash, but does not display the cycles and options and will not turn off.

1. Remove top panel, left side panel, and console to access the machine electronics.
2. Verify that the harness is in good condition and check the UI and J17 connections; check for continuity. If no continuity, replace the harness.
3. If the problem persists, replace the ACU.
4. If the problem persists, replace the UI.

### CONNECTOR LOCATION (ACU TOP)

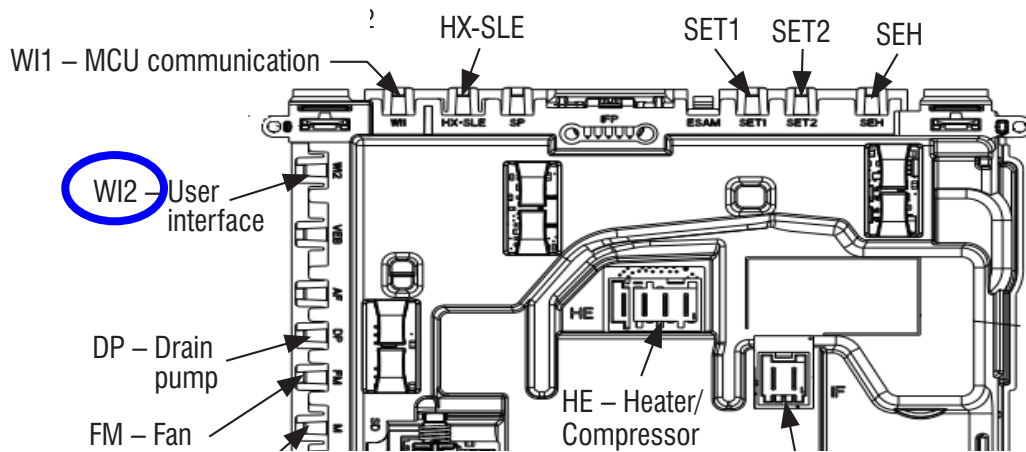

Figure 1 - User Interface Connector (W12)

### USER INTERFACE STRIP CIRCUIT

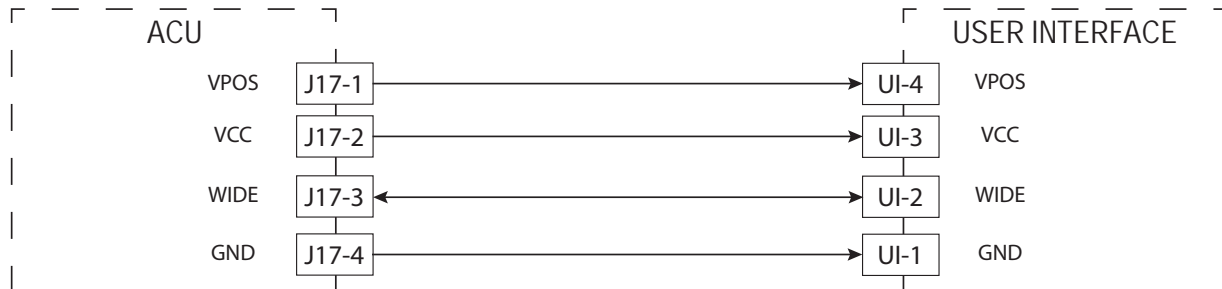

Figure 2 - User Interface Strip Circuit

## Section 4: Component Access

This section provides service parts, assemblies, and component locations for the “Whirlpool Compact Heat Pump Dryer.”

- Parts & Assemblies-Top and Console Parts
- Parts & Assemblies-Cabinet Parts
- Parts & Assemblies-Base Parts
- Parts & Assemblies-Drum and Bulkhead Parts
- Parts & Assemblies-Door Parts
- Removing the Door Assembly & Door Components
- Removing the Top & Side Panels
- Removing the Interference Filter
- Removing the Console/User Interface
- Removing the Appliance Control Unit (ACU)
- Removing the Water Tank Housing
- Removing the Drive Motor
- Removing the Drain Pump, Float Sw. and Fan Ass’y
- Removing the Front Panel
- Removing the Drum
- Removing the Bulkhead
- Removing the Back Panel
- Removing the Heat Pump (Base Assembly)

# Parts & Assemblies

## TOP AND CONSOLE PARTS

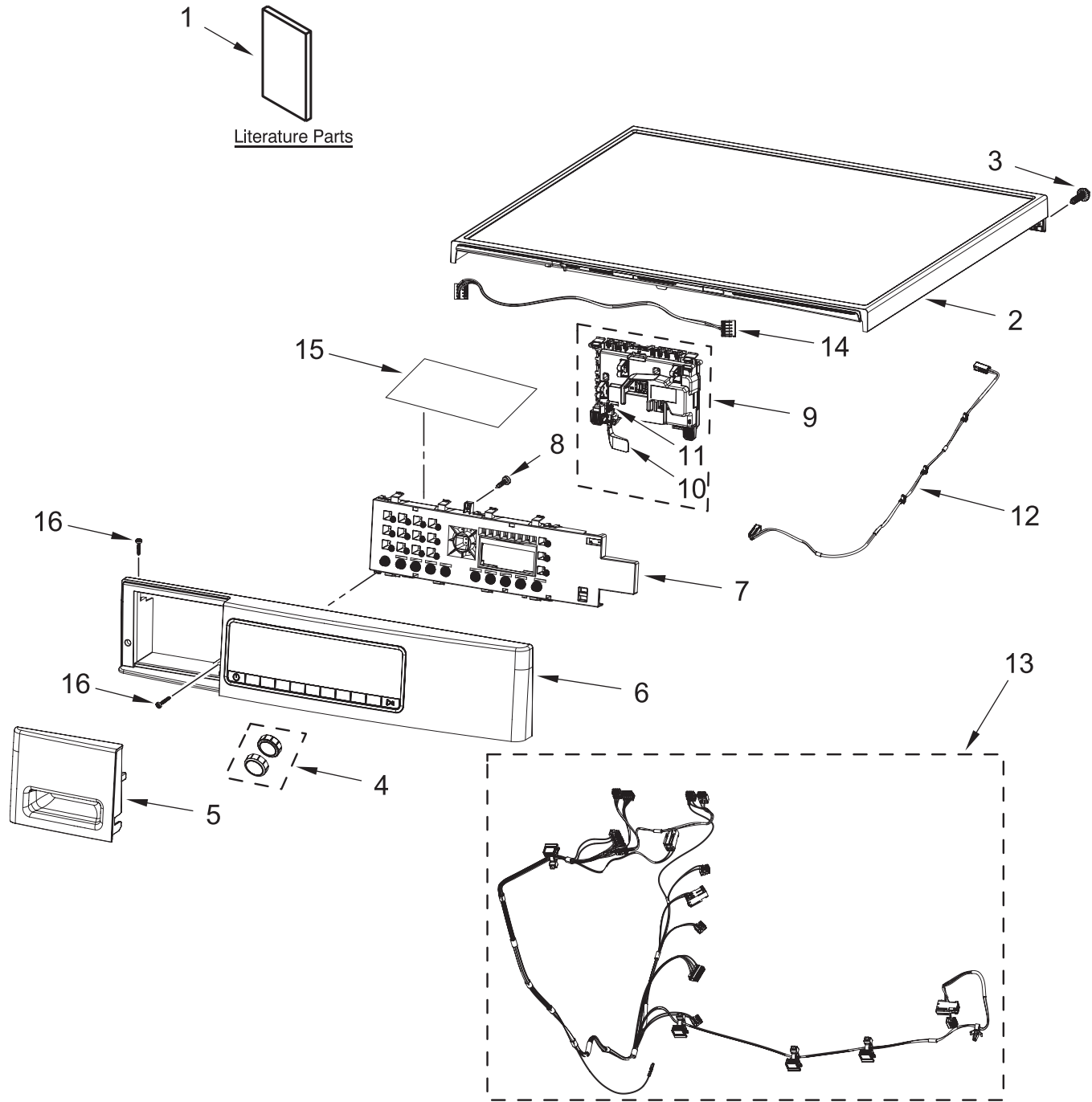

1 Literature Parts

2 Top, White

3 Screw

4 Assembly, Control Knob

5 Handle, Drawer White

6 Assembly, Console White

7 User Interface

8 Screw

9 Appliance Control Unit (ACU)

10 Lever, Door Switch

11 Spring, Door Switch

12 Harness, RFI

13 Harness, Main

14 Harness, UI

15 Shield, UI (Foil)

16 Screw

# Parts & Assemblies

## CABINET PARTS

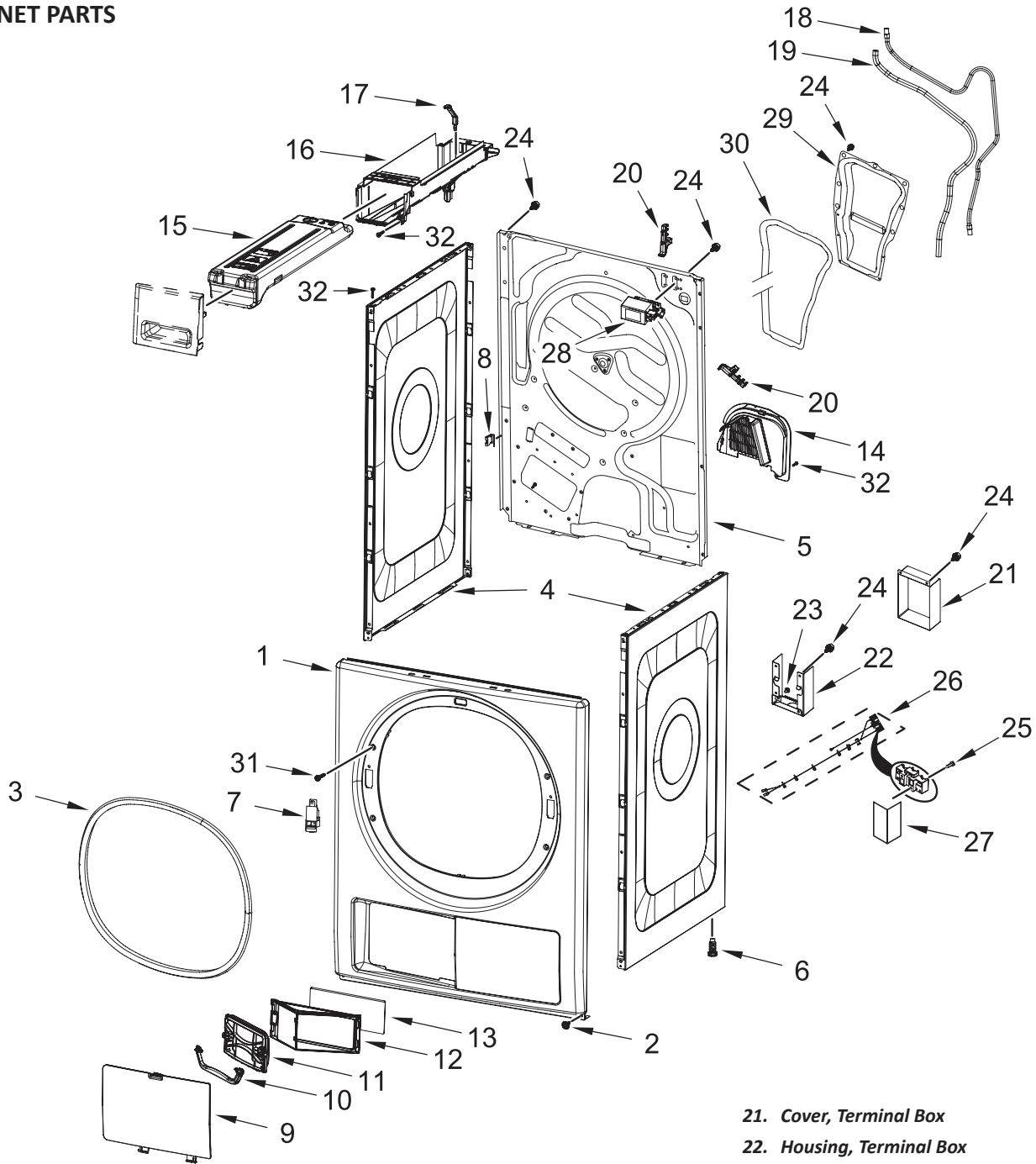

- |                                       |  |                                       |
|---------------------------------------|--|---------------------------------------|
| 1 Panel, Front White                  | 11. Filter, Cover                        | 21. Cover, Terminal Box               |
| 2. Screw                              | 12. Filter, Frame                        | 22. Housing, Terminal Box             |
| 3. Seal (Front Panel - Door)          | 13. Filter, Foam                         | 23. Screw                             |
| 4. Panel, Side White                  | 14. Access Door (Pump - Rear Panel)      | 24. Screw                             |
| 5. Panel - Rear, Dryer Bulkhead White | 15. Tank, Water                          | 25. Screw                             |
| 6. Foot                               | 16. Housing, Water Tank                  | 26. Harness, Terminal Block           |
| 7. Lock, Door                         | 17. Pipe, Water Tank Inflow              | 27. Insulator, Terminal Block Harness |
| 8. Clip, Grounding                    | 18. Hose (Inflow to Pump)                | 28. Filter, RFI                       |
| 9. Filter Door (Front Panel)          | 19. Hose, Over Fill (Water Tank to Pump) | 29. Cover, Heater                     |
| 10. Filter, Handle                    | 20. Bracket, Hose                        | 30. Seal, Heater Cover                |
|                                       |  | 31. Screw                             |
|                                       |  | 32. Screw                             |

# Parts & Assemblies

## BASE PARTS

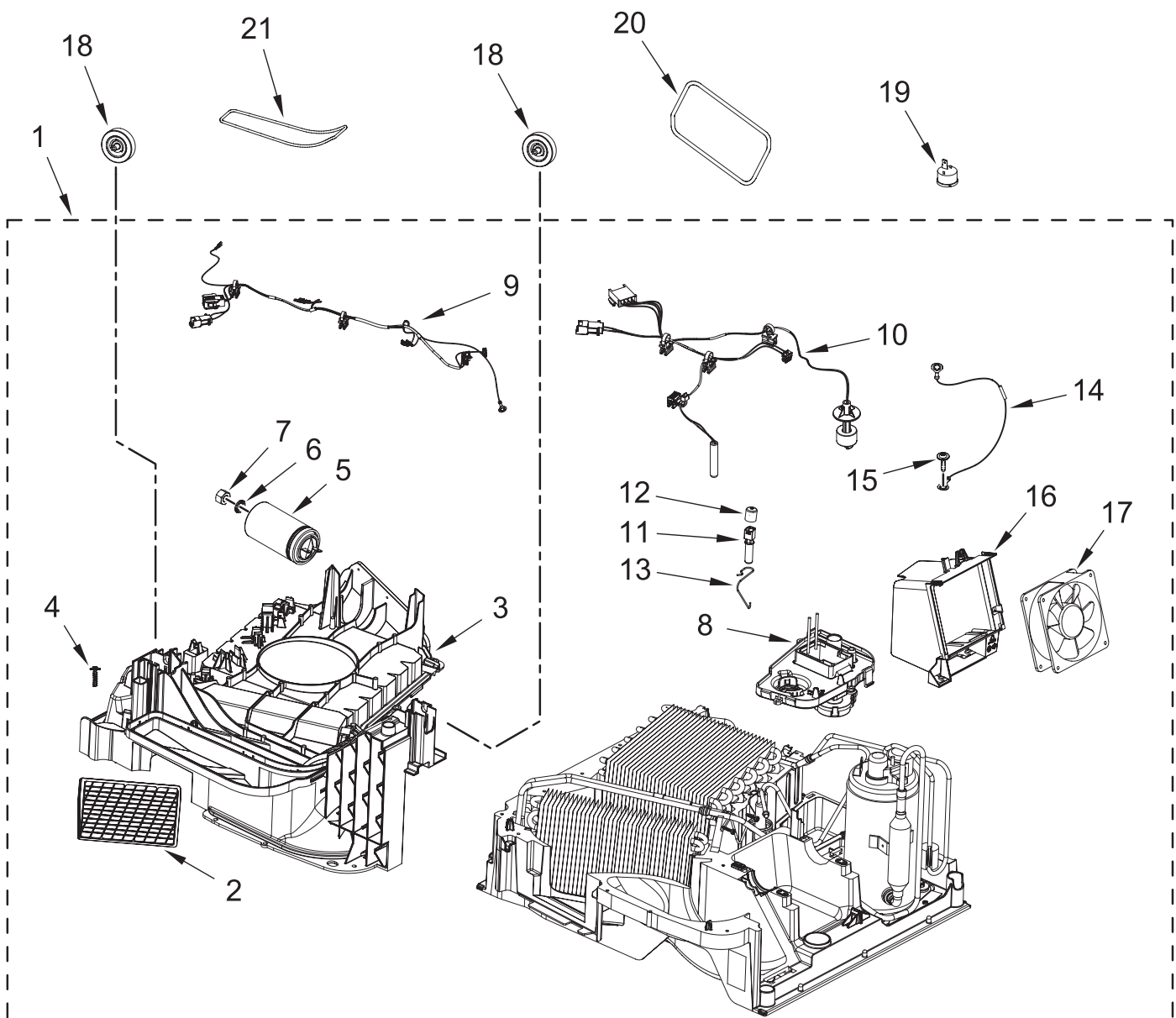

1. Base Unit

2. Filter, Base

3. Cover, Base Unit

4. Screw

5. Capacitor

6. Washer, Lock

7. Nut

8. Pump Assembly

9. Harness, Compressor

10. Harness, NTC

11. Sensor, NTC

12. Cap, NTC

13. Spring, NTC

14. Harness, Heat Pump (Ground)

15. Screw

16. Housing, Fan

17. Fan

18. Roller, Support

19. Compressor Thermal Overload Protector

20. Seal, Base to Rear Panel

21. Seal, Base to Front Bulkhead

# Parts & Assemblies

## MOTOR PARTS

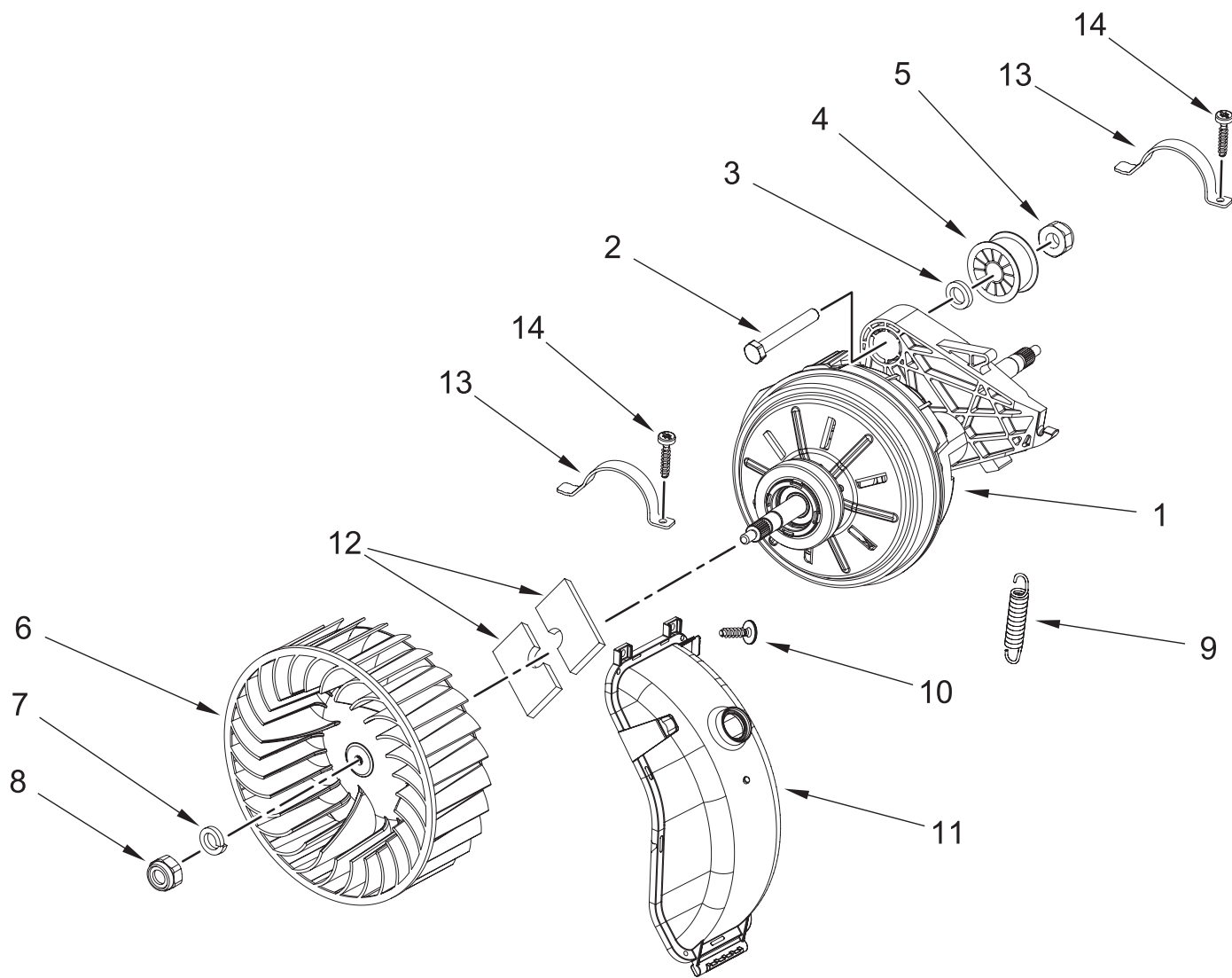

1 Motor

2 Bolt

3 Washer

4 Pulley, Idler

5 Nut

6 Wheel, Blower

7 Washer

8 Nut

9 Spring, Belt Tension

10 Screw

11 Cover, Blower

12 Seal, Motor to Blower

13 Bracket, Motor

14 Screw

# Parts & Assemblies

## DRUM AND BULKHEAD PARTS

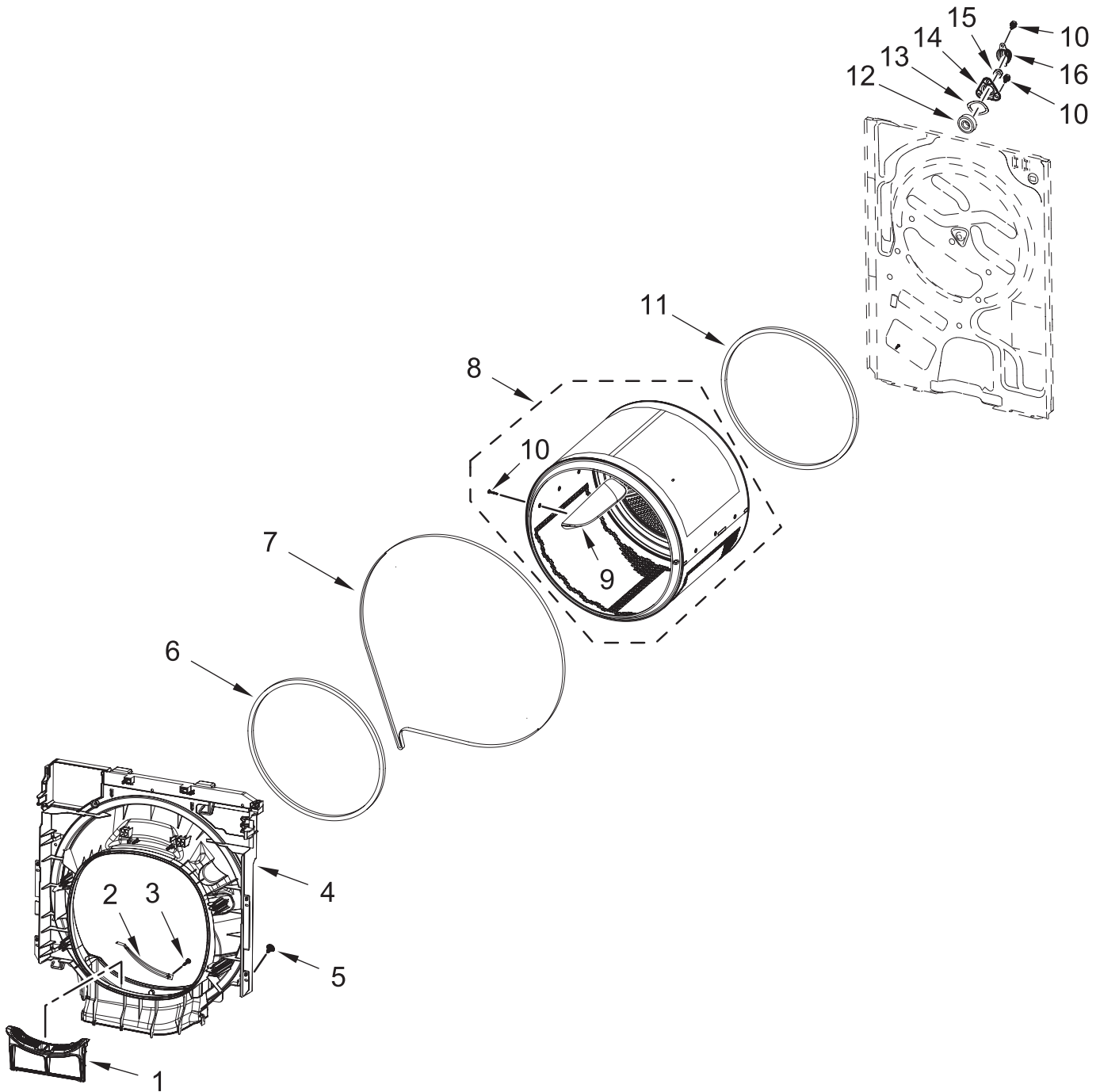

- 1 Lint Screen
- 2 Sensor, Humidity
- 3 Screw
- 4 Bulkhead, Front
- 5 Screw

- 6 Seal, Drum (Front)
- 7 Belt, Drum
- 8 Assembly, Drum (Complete)
- 9 Baffle, Drum
- 10 Screw

- 11 Seal, Drum (Rear)
- 12 Bearing, Drum (Axis)
- 13 Washer, Spring
- 14 Housing, Bearing (Axis)
- 15 Nut
- 16 Cover, Bearing (Axis)

# Parts & Assemblies

## DOOR PARTS

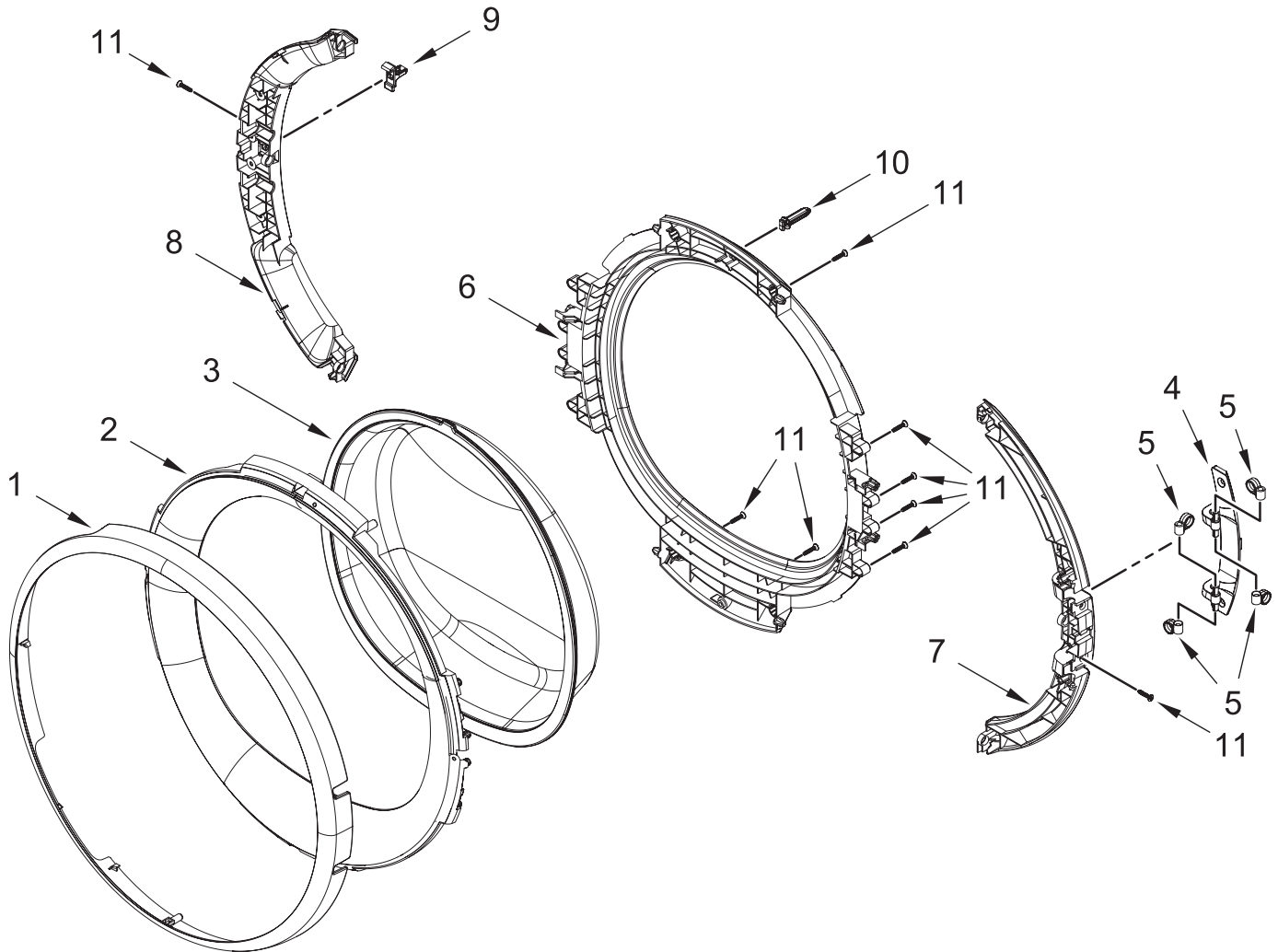

- 1 Door, Outer Trim Ring
- 2 Door, Inner Trim
- 3 Door, Glass
- 4 Hinge, Door

- 5 Bushing, Hinge (Outer)
- 6 Door, Inner
- 7 Door, Inner (Hinge)
- 8 Door, Inner (Lock)

- 9 Lock, Door
- 10 Pin, Run/Stop
- 11 Screw

# Removing the Door Assembly & Door Components

### To Remove the Door Assembly

1. Open door.
2. Use a T20 Torx driver to remove the two (2) hinge screws.
3. Lift up door assembly to disengage hinge from the front panel. Remove door assembly.

### To Remove the Door Strike Assembly

1. Open door.
2. Using a flat-blade screwdriver, insert the screwdriver as shown in Figures 1 below. At the same time, push down on the strike until it unclips from the door (see Figure 2). Remove the strike assembly from the door.



Figure 1



Figure 2

### To Remove the Door Catch Assembly

1. Open door.
2. Use a T20 Torx driver to remove the one screw securing the door catch to the front panel (see Figure 3).

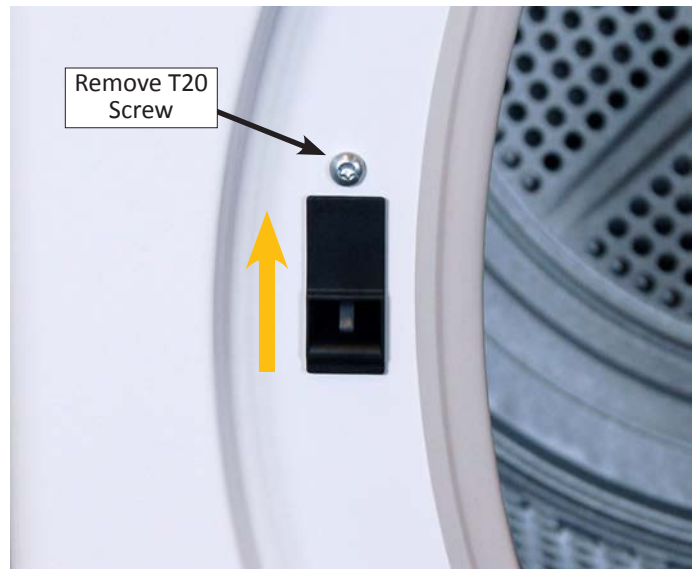

Figure 3

3. Slide the door catch upward while pulling the bottom of the catch away from the front panel (see Figure 3).
4. Reverse procedure to reinstall.

### To Remove the Door "Run/Stop" Pin

1. Open door.
2. Using a pair of pliers, grasp the "run/stop" pin (used to depress the door switch paddle) and rotate the pin counter-clockwise 1/4 turn. See Figure 4.

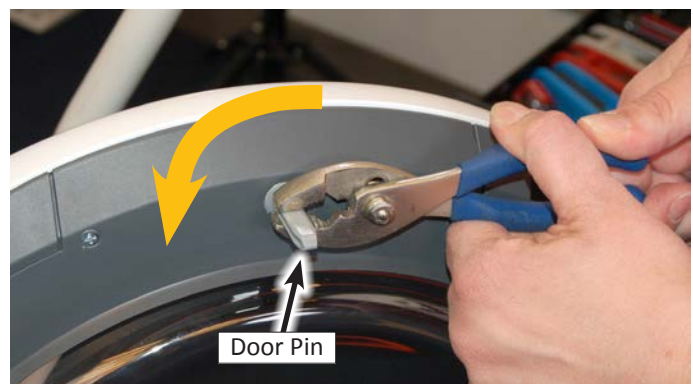

Figure 4

3. Remove the "run/stop" pin from the door assembly.

## Removing the Top & Side Panels

**⚠ WARNING**



**Electrical Shock Hazard**  
**Disconnect power before servicing.**  
**Replace all parts and panels before operating.**  
**Failure to do so can result in death or electrical shock.**

### To Remove the Side Panel(s)

Access to the base components can be achieved by removing either the right or left side panels. The service technician can access the compressor components or the motor and blower assembly by removing the right side panel. Removing the left side panel provides access to the base component connectors for ease in diagnostics.

1. Perform the procedure “Remove the Top Panel” on this page prior to performing the following steps.
2. Use a T20 Torx driver to remove the three (3) screws from the back of one or both side panel(s), (circled in Figure 1).
3. If removing the right side panel, detach the three harness clips affixed to the top of the panel. See Figure 2.
4. Use a T20 Torx driver to remove the top-front two (2) screws on one or both side panel(s). See Figure 2.

### To Remove the Top Panel

1. Unplug dryer or disconnect power.
2. Remove the three (3) 7mm hex-head screws from the top panel as illustrated in Figure 1.
3. Lift the rear of the top panel, pull back, and remove top panel from the dryer.



Figure 1

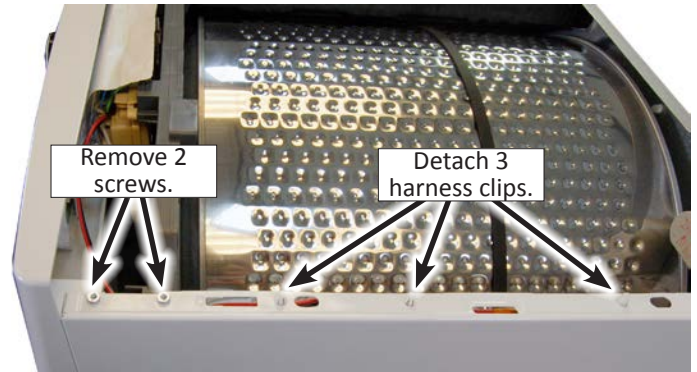

Figure 2

5. Use a T20 Torx driver to remove the one (1) screw from the lower-front of one or both side panel(s) (see Figure 3).

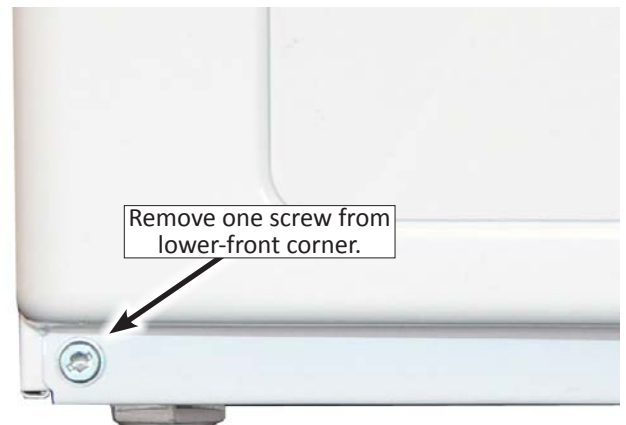



Figure 2

6. Lift up on side panel(s) and remove from dryer.
7. Reverse procedure to reinstall side panel(s).

## Removing the Interference Filter

**⚠ WARNING**



**Electrical Shock Hazard**  
Disconnect power before servicing.  
Replace all parts and panels before operating.  
Failure to do so can result in death or electrical shock.

- Slide the Interference Filter horizontally to release the filter from back panel. See Figure 2.

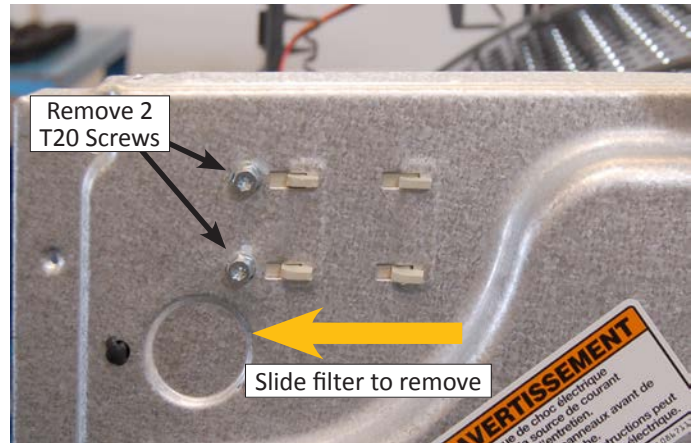

Figure 2

**NOTE:** When reinstalling the filter, the black wire is on top and the red wire is on the bottom (see Figure 1).

### To Remove the Interference Filter

- Unplug dryer or disconnect power.
- Perform the procedure on page 4-9, "Remove the Top Panel" prior to performing the following steps.
- Remove the harnesses from the Interference Filter (see Figure 1).

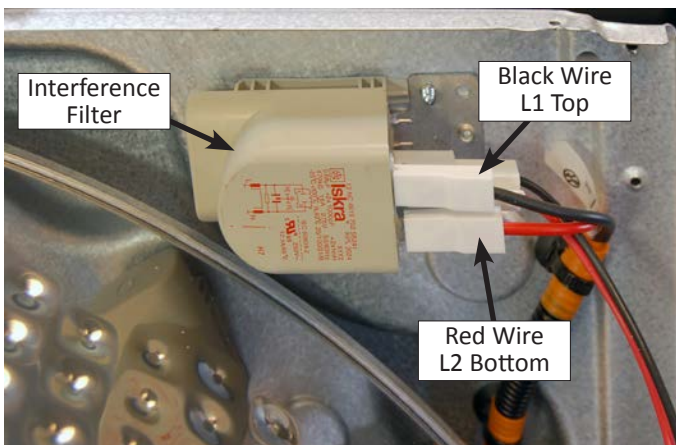



Figure 1

- Use a T20 Torx driver to remove the two (2) screws securing the Interference Filter to the rear panel. See Figure 2.

## Removing the Console/User Interface

**⚠ WARNING**



**Electrical Shock Hazard**

**Disconnect power before servicing.**

**Replace all parts and panels before operating.**

**Failure to do so can result in death or electrical shock.**

### To Remove the Console/User Interface

1. Unplug dryer or disconnect power.
2. Perform the procedure on page 4-9, "Remove the Top Panel" prior to performing the following steps.
3. Remove the water tank from the dryer.
4. Remove the T20 Torx screw next to the water tank opening (see Figure 1).



Figure 1

5. Perform the procedure on page 4-9, "Remove the Side Panel(s)" to remove the "left" side panel.
6. Remove the "front" T20 Torx screws located on the top-front, right-side panel (see Figure 2).



Figure 2

7. On the left side of the dryer (left panel should be removed) gently lift up on the left console tab to disengage left side of console from the front bulkhead (see Figure 3).

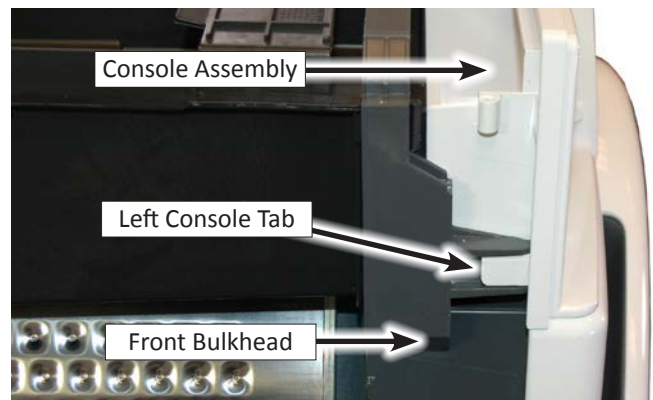

Figure 3

8. Swivel the Console/UI out and unclip the right-side console tab from the bulkhead (see Figure 4).

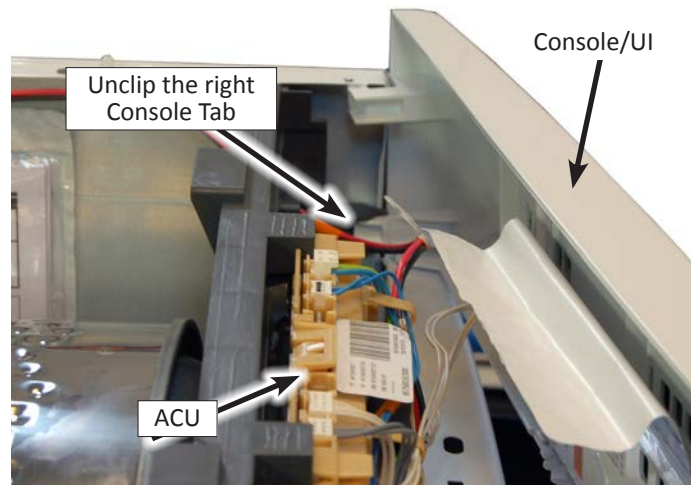

Figure 4

9. Disconnect the UI harness and remove the Console/UI from the dryer.

# Removing the Appliance Control Unit (ACU)

⚠ **WARNING**



Electrical Shock Hazard

Disconnect power before servicing.  
Replace all parts and panels before operating.  
Failure to do so can result in death or electrical shock.

## Appliance Control Unit (ACU)

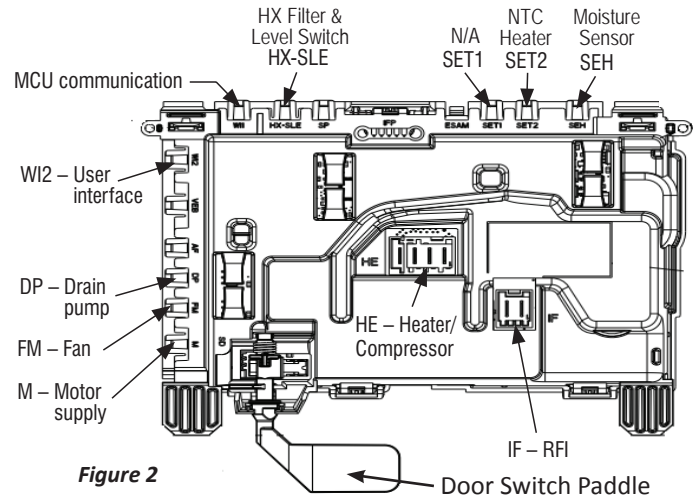

Figure 2

### To Remove the Appliance Control Unit (ACU)

1. Unplug dryer or disconnect power.
2. Perform the procedure on page 4-11, "Remove the Console /User Interface" prior to performing the following steps.
3. Disconnect all connectors from the ACU and remove the harnesses from the routing clips. See Figure 1.
4. Depress the top right and left tabs to release ACU from the front bulkhead. See Figure 1.

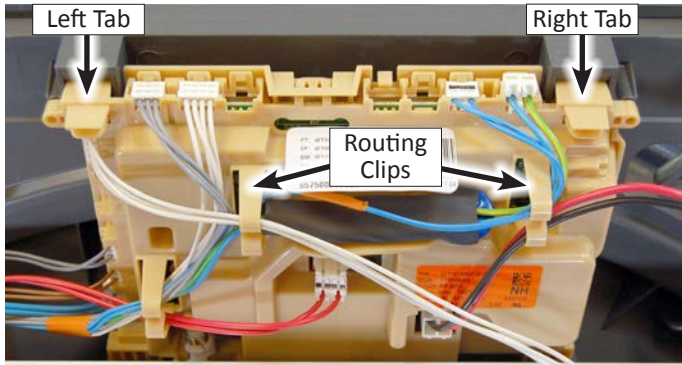

Figure 1

5. Tilt out and remove ACU taking care not to hit the door switch paddle.

### ACU Connectors & Pinouts

#### IF – RFI

- J13-1 L1 In
- J13-2 L2 In

#### HE – Compressor

- J5-1 L2 Compressor
- J5-2 L1 Compressor

#### FM – Auxiliary Fan

- J2-1 L1 Fan
- J2-3 L2 Fan

#### DP – Drain Pump

- J3-1 L1 Pump
- J3-3 L2 Pump

#### M – Motor Supply

- J4-1 L1 Motor
- J4-2 L2 Motor

#### W11 – MCU Communication

- J12-2 +12 VDC
- J12-3 IN/OUT
- J12-4 GND

#### W12 – User Interface

- J17-1 VPOS
- J17-2 +5 VDC
- J17-3 WIDE
- J17-4 GND

#### SEH – Moisture Sensor

- J11-1 GND
- J11-3 Moisture Sensor

#### HX-SLE – Heat Exchanger Filter and Level Switch

- J8-1 HX Filter Sw 1
- J8-2 HX Filter Sw 2
- J8-3 Water Lvl Sw 1
- J8-4 Water Lvl Sw 2

#### SET2 – NTC Heater

- J6-1 NTC Heat 1
- J6-3 NTC Heat 2

## Removing the Water Tank Housing

<b>⚠ WARNING</b>

<p style="text-align: center;"><b>Electrical Shock Hazard</b></p> <p><b>Disconnect power before servicing.</b></p> <p><b>Replace all parts and panels before operating.</b></p> <p><b>Failure to do so can result in death or electrical shock.</b></p>

### To Remove the Water Tank Housing

1. Unplug dryer or disconnect power.
2. Perform the procedure on page 4-11, "Remove the Console/User Interface" prior to performing the following steps.
3. From the back of the dryer, disconnect the inlet and outlet hoses from the water tank housing (see Figure 1).

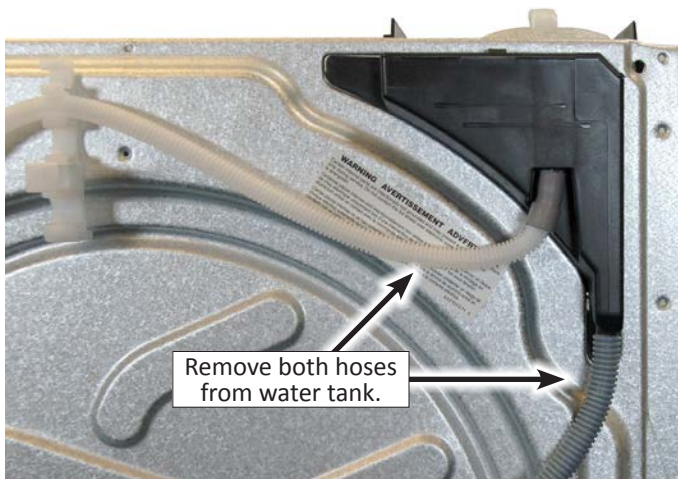

Figure 1

3. Unclip the two front tabs on the water tank (see Figure 2).



Figure 2

4. Push back on the water tank housing and lift up from the front bulkhead.
5. Depress the top tab on the back of the water tank housing (see Figure 3).

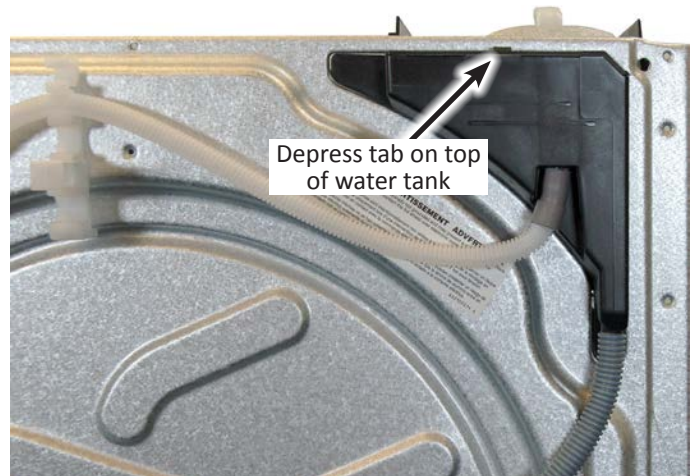



Figure 3

6. Gently push the water tank housing into the dryer and up through the top using care not to damage the lower tab on the back of the housing.

## Removing the Drive Motor

⚠ WARNING



**Electrical Shock Hazard**

**Disconnect power before servicing.**

**Replace all parts and panels before operating.**

**Failure to do so can result in death or electrical shock.**

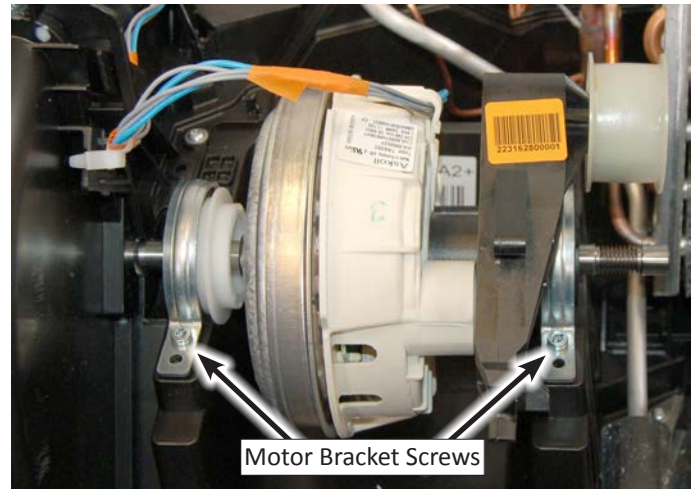

Figure 2

### To Remove the Drive Motor

1. Unplug dryer or disconnect power.
2. Perform the procedure on page 4-9, "Remove the Top Panel" prior to performing the following steps.
3. Perform the procedure on page 4-9, "Remove the Side Panel(s)" to remove the "right" side panel.
4. Use needle nose pliers to remove tension spring from drive motor (see Figure 1). Remove belt from tensioner.
5. Disconnect the motor harness clip from the blower wheel cover.
6. Remove the T20 Torx screw from the blower wheel cover (as illustrated in Figure 1).
7. Depress the two tabs to release the blower wheel cover. Then, rotate blower cover down. See Figure 1.

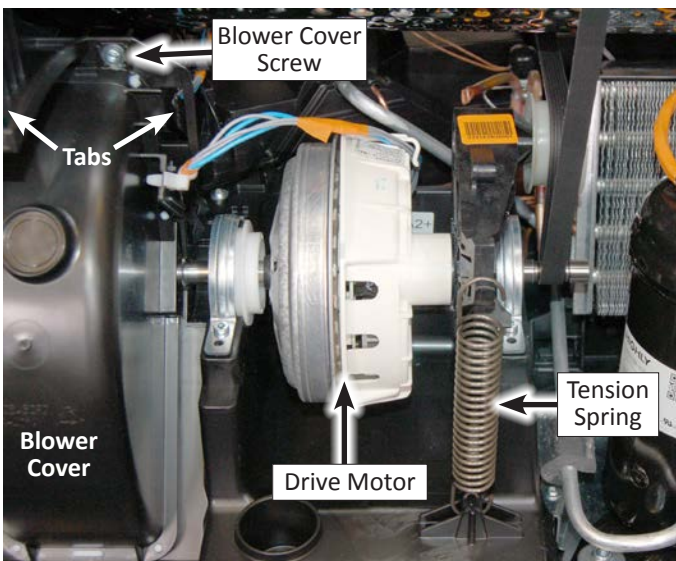

Figure 1

8. Use a T20 Torx driver to remove the two screws securing the motor brackets (see Figure 2). Remove brackets and set aside.

9. Lift up and rotate out the motor assembly and blower wheel. See Figure 3.
10. Disconnect both the motor power harness (BLUE) and the motor controller communication harness (GRAY).

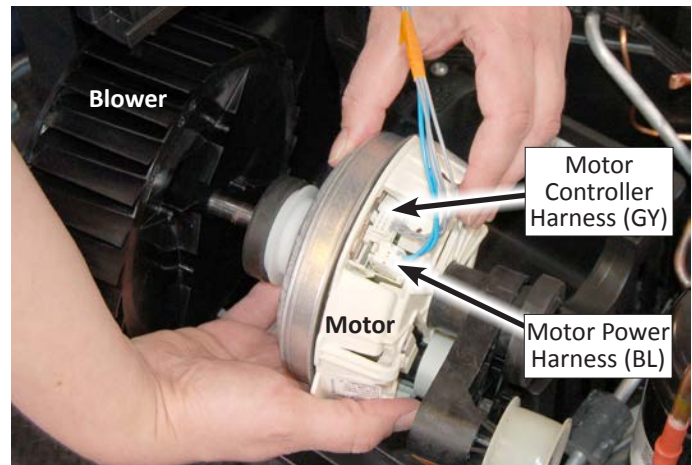

Figure 3

11. Reverse procedure to reinstall motor and blower assembly.

## Removing the Drain Pump, Float Sw. and Fan Assemblies

### ⚠ WARNING



**Electrical Shock Hazard**  
 Disconnect power before servicing.  
 Replace all parts and panels before operating.  
 Failure to do so can result in death or electrical shock.

### To Remove the Pump, Float and Fan Assemblies

1. Unplug dryer or disconnect power.
2. Perform the procedure on page 4-9, "Remove the Top Panel" prior to performing the following steps.
3. Perform the procedure on page 4-9, "Remove the Side Panel(s)" to remove the "left" side panel (see Figure 1).

**NOTE:** Step 3 is necessary to access the drain pump, float switch, and fan harness connections.

**NOTE:** The Pump and Float Switch can be replaced as separate components. However, the Float Switch shares the same connector with the HX (Heat Exchanger) Lint Filter Sensor.

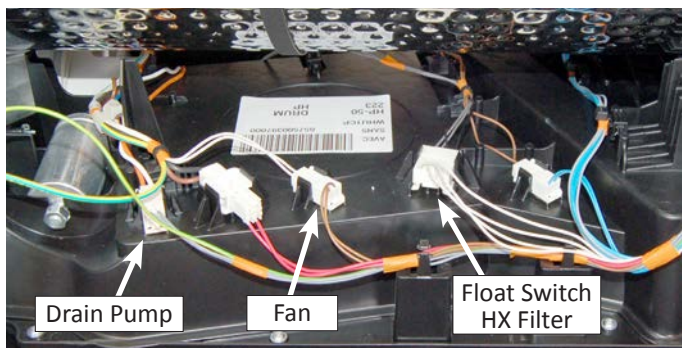

Figure 1

4. If not already, remove the two hoses (drain pump and overflow hoses) from the sump assembly.

5. Use a T20 Torx driver to remove the two (2) screws securing sump bracket to the back panel (as illustrated in Figure 2). Remove sump bracket and set aside.

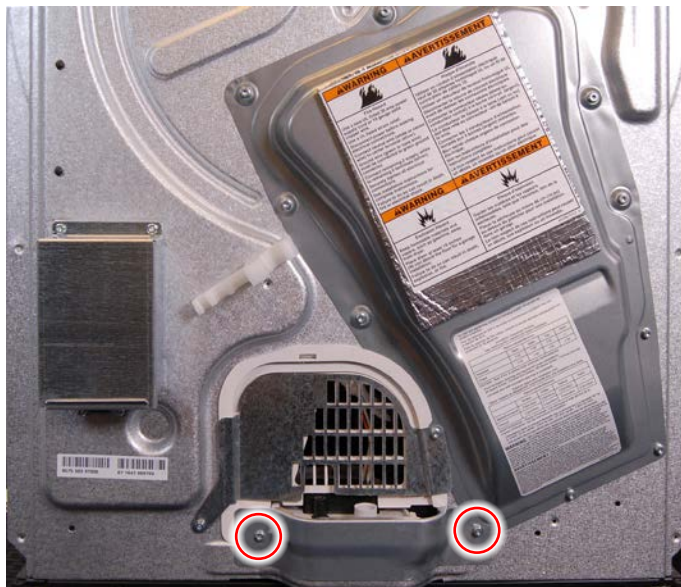

Figure 2

6. Use a T20 Torx driver to remove the two (2) screws securing the access cover bracket to the back panel (as illustrated in Figure 3). Remove cover bracket and set aside.

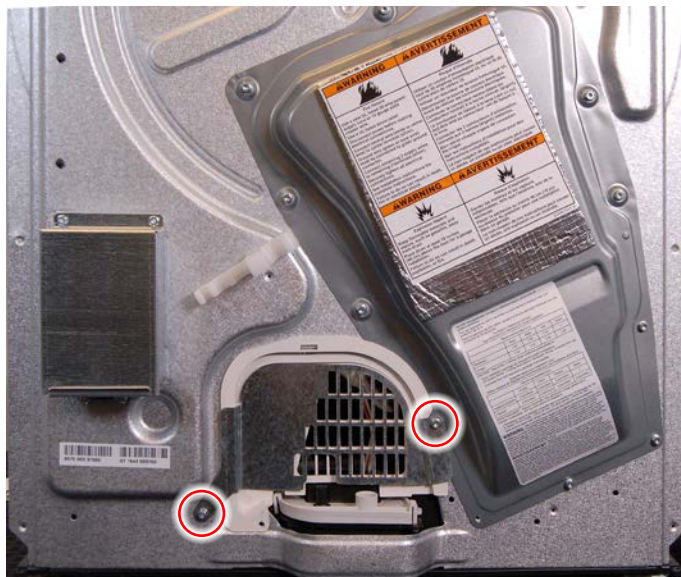

Figure 3

Continued on next page . . .

## COMPONENT ACCESS

# Removing the Drain Pump, Float Sw. and Fan Assemblies (cont.)

7. Remove the plastic access cover and set aside (see Figure 4).

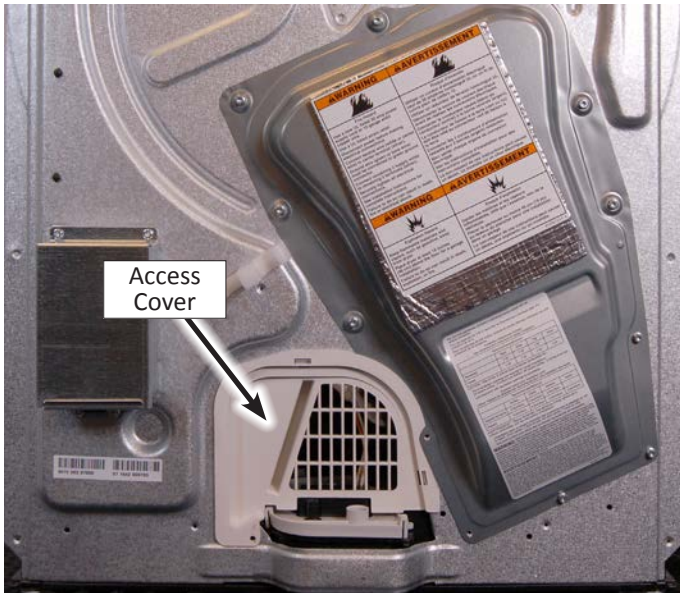

Figure 4

### To Remove the Pump and Float Assembly

8. Depress the tabs on both sides of the sump assembly. Lift the sump up and slide out to disengage the rear clips (see Figure 5).

**NOTE:** Be sure to disconnect the pump and/or float switch harnesses before removing the assembly from the dryer.

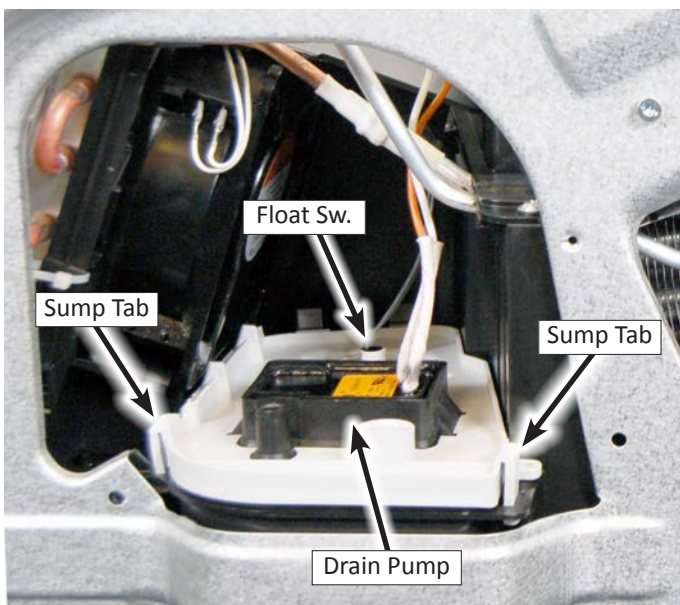

Figure 5

### To Remove the Fan Assembly

9. Locate the post condenser fan motor assembly, mounted to the left of the sump assembly (see Figure 6 below).

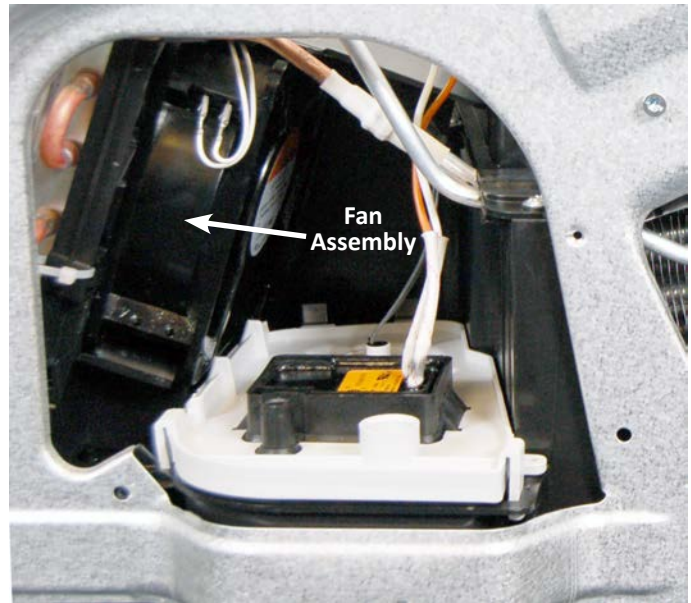

Figure 6

10. If exists, cut the wire tie securing the fan to the post condenser (see Figure 7).  
11. Disconnect the wire terminals from the fan assembly.  
12. Depress the release tab and slide the fan assembly out of the dryer (see Figure 7).

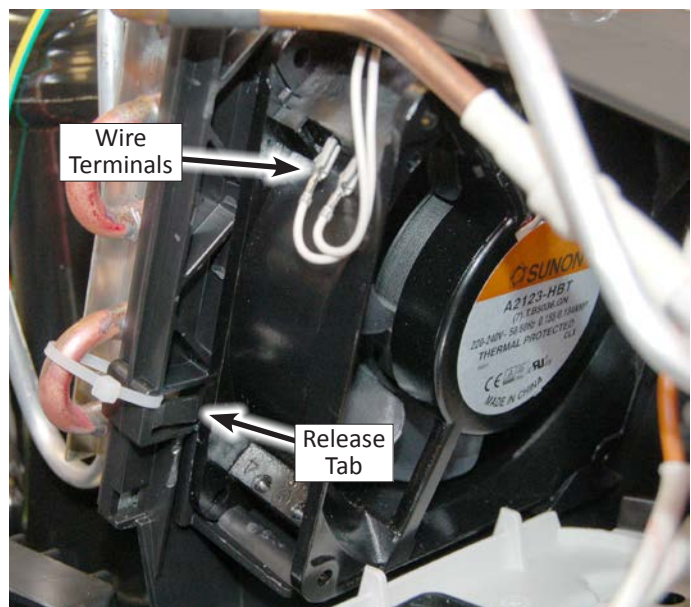

Figure 7

## Removing the Front Panel

### **WARNING**



**Electrical Shock Hazard**  
 Disconnect power before servicing.  
 Replace all parts and panels before operating.  
 Failure to do so can result in death or electrical shock.

### To Remove the Front Panel

1. Unplug dryer or disconnect power.
2. Perform the procedure on page 4-8, "Remove the Door Assembly" prior to performing the following steps.
3. Perform the procedure on page 4-9, "Remove the Top Panel" prior to performing the following steps.
4. Perform the procedure on page 4-9, "Remove the Side Panels" prior to performing the following steps.
5. Perform the procedure on page 4-11, "Remove the Console/User Interface" prior to performing the following steps.
6. Remove door lint filter and bottom HX Filter.
7. Remove the two T20 Torx screws on the opposite side of the door hinge (see Figure 1).



Figure 1

8. Using a T20 Torx driver, remove the 4 inside screws, 2 on each side of the inner front panel. See Figure 2.

Remove two (2) T20 screws on each side of inner front panel.



Figure 2

9. Pull front panel away from the front bulkhead.

## Removing the Drum

⚠ **WARNING**



**Electrical Shock Hazard**

**Disconnect power before servicing.**

**Replace all parts and panels before operating.**

**Failure to do so can result in death or electrical shock.**

### To Remove the Drum

1. Unplug dryer or disconnect power.
2. Perform the procedure on page 4-9, "Remove the Top Panel" prior to performing the following steps.
3. Perform the procedure on page 4-9, "Remove the Side Panels" prior to performing the following steps.
4. Perform the procedure on page 4-11, "Remove the Console/User Interface" prior to performing the following steps.
5. Perform the procedure on page 4-13, "Remove the Water Tank" prior to performing the following steps.
6. Use needle nose pliers to remove tension spring from drive motor (see Figure 1).

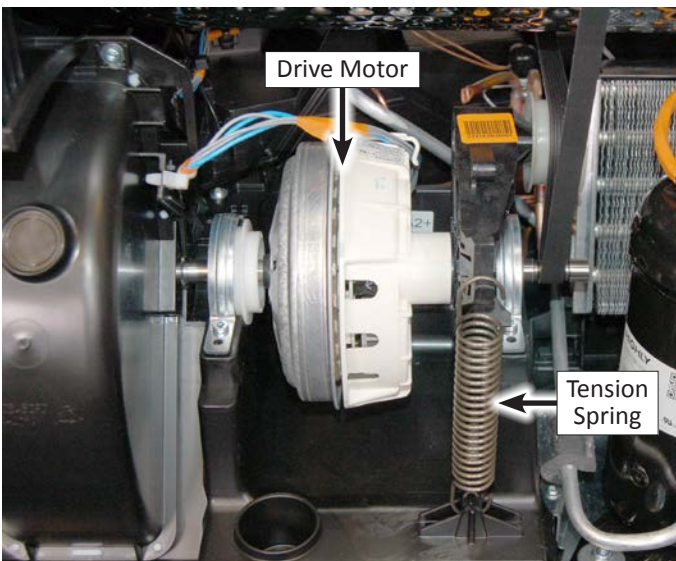

Figure 1

7. Remove Drum Bearing Assembly. (See Figures 2–5.)



Figure 2 - Drum Bearing Assembly

- a. Remove the bottom screw using a 7mm hex-head driver. Remove screw and bearing cover (see Figure 3). **WARNING:** do not remove or lose the copper ground terminal inside the bearing cover (see Figure 4).



Figure 3



Figure 4

- b. Remove the top two (2) screws using a 7mm hex-head driver. Remove the screws, bearing housing and spring washer (see Figure 5). **WARNING:** do not lose the spring washer or bearing housing (see Figure 6).



Figure 5



Figure 6

- c. Using a 10mm nut driver, remove the nut, then remove the drum bearing from the drum shaft. See Figure 7.



Figure 7

8. Spread rear & front bulkheads and lift drum away from dryer.

## Removing the Front Bulkhead

### **⚠ WARNING**



**Electrical Shock Hazard**  
 Disconnect power before servicing.  
 Replace all parts and panels before operating.  
 Failure to do so can result in death or electrical shock.

### To Remove the Front Bulkhead

1. Unplug dryer or disconnect power.
2. Perform the procedure on page 4-9, "Remove the Top Panel" prior to performing the following steps.
3. Perform the procedure on page 4-9, "Remove the Side Panels" prior to performing the following steps.
4. Perform the procedure on page 4-11, "Remove the Console/User Interface" prior to performing the following steps.
5. Perform the procedure on page 4-13, "Remove the Water Tank" prior to performing the following steps.
6. Perform the procedure on page 4-17, "Remove the Front Panel" prior to performing the following steps.
7. Perform the procedure on page 4-18, "Remove the Drum" prior to performing the following steps.
8. Disconnect the moisture sensor harness.
9. Remove the main harness run from the front of the bulkhead. The harness is secured to the bulkhead by one clip and 2 or 3 guides. See Figure 2 in the next column.
10. Remove the two 7 mm screws securing the front bulkhead to the base assembly (see Figure 1 below).
11. Locate the right and left-side clips securing the front bulkhead to the base assembly (see inset in Figure 2.) Lift up and remove the front bulkhead assembly from the base.

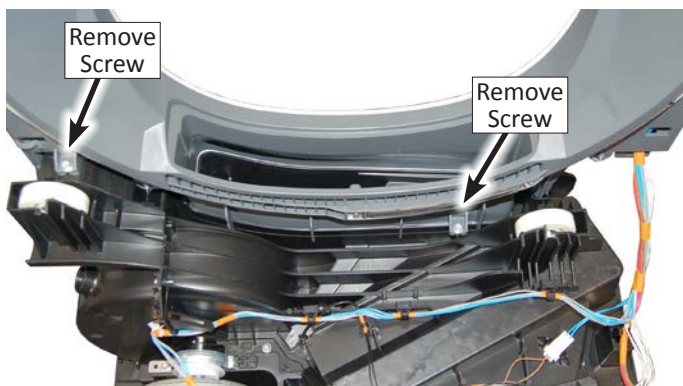

Figure 1

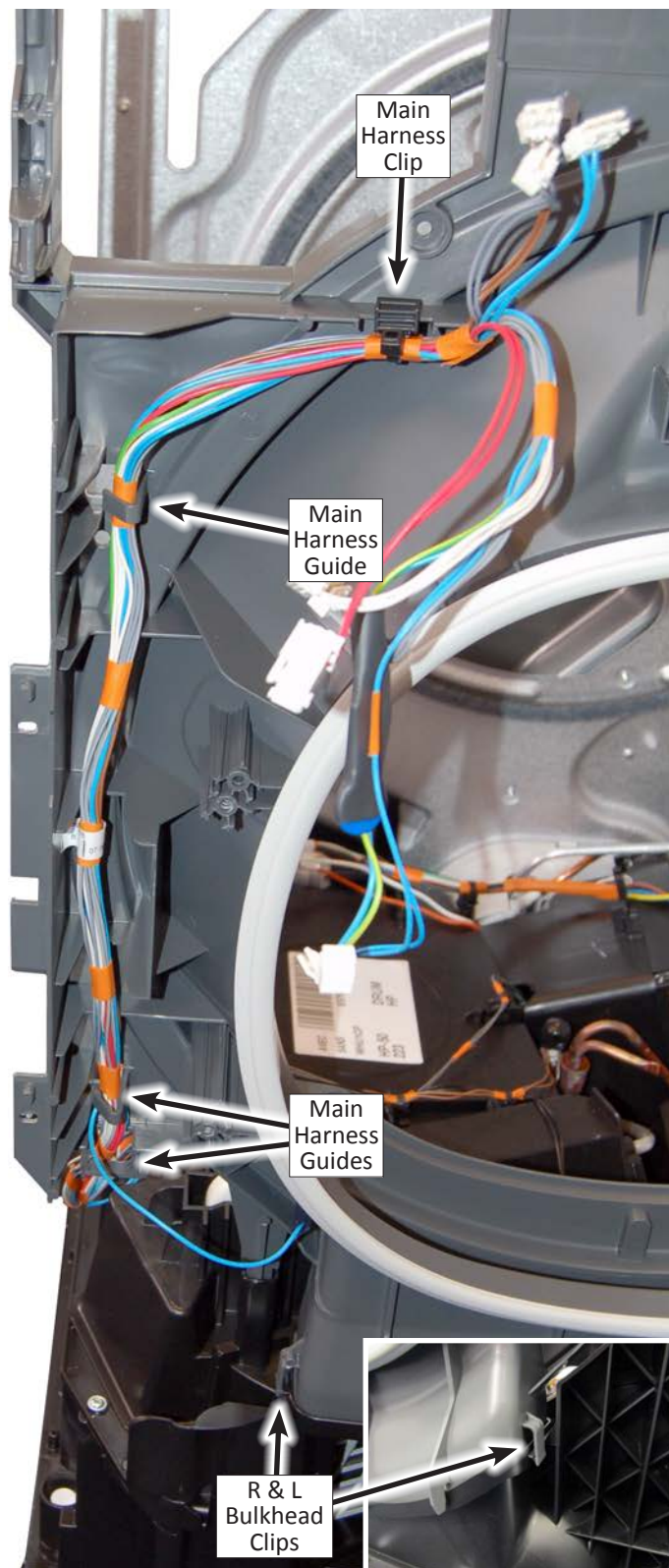



Figure 2

## Removing the Back Panel

⚠ **WARNING**



**Electrical Shock Hazard**

**Disconnect power before servicing.**

**Replace all parts and panels before operating.**

**Failure to do so can result in death or electrical shock.**

### To Remove the Back Panel

**NOTE:** On this dryer model, the back panel is also the rear bulkhead. This design requires the top & side panels, console, water tank, and drum removal before the back panel can be removed from the dryer.

1. Unplug dryer or disconnect power.
2. Perform the procedure on page 4-9, "Remove the Top Panel" prior to performing the following steps.
3. Perform the procedure on page 4-9, "Remove the Side Panels" prior to performing the following steps.
4. Perform the procedure on page 4-10, "Remove the Interference Filter" to either disconnect or remove the filter prior to performing the following steps.
5. Perform the procedure on page 4-11, "Remove the Console /User Interface" prior to performing the following steps.
6. Perform the procedure on page 4-13, "Remove the Water Tank" prior to performing the following steps.
7. Perform the procedure on page 4-18, "Remove the Drum" prior to performing the following steps.
8. If not already, remove the two hoses (drain pump and overflow hoses) from the back of the dryer.
9. Disconnect the two ground terminals from the back panel (see Figure 1).

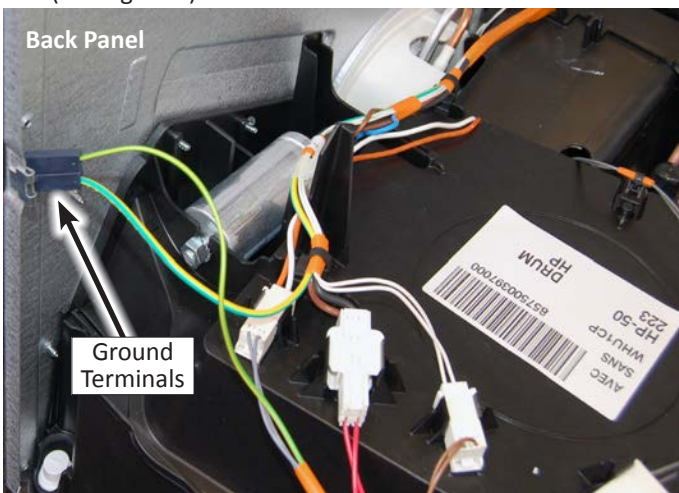

Figure 1

10. Use a T20 Torx driver to remove the three (3) back panel screws illustrated in Figure 2.



Figure 2

11. Use a T20 Torx driver to remove the two (2) screws securing sump bracket to the back panel (as illustrated in Figure 3). Remove sump bracket and set aside.

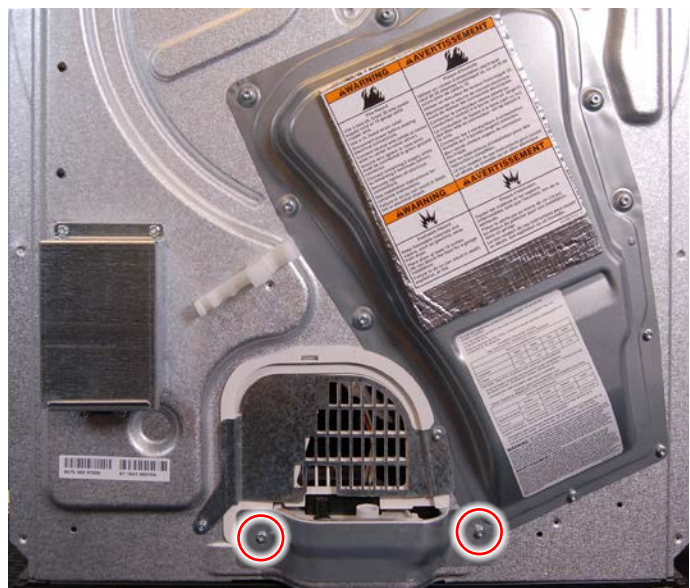

Figure 3

Continued on next page . . .

## Removing the Back Panel (continued)

12. Use a T20 Torx driver to remove the two (2) screws securing the access cover bracket to the back panel (as illustrated in Figure 4). Remove cover bracket and set aside.

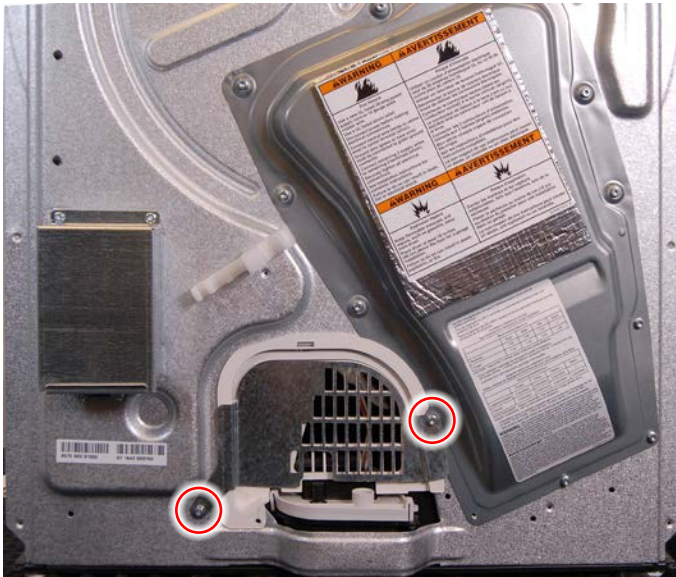

Figure 4

13. Remove the plastic access cover and set aside (see Figure 5).



Figure 5

14. Use a T20 Torx driver to remove the ten (10) screws securing heat channel cover to the back panel (as illustrated in Figure 6). Remove the heat channel and set aside.

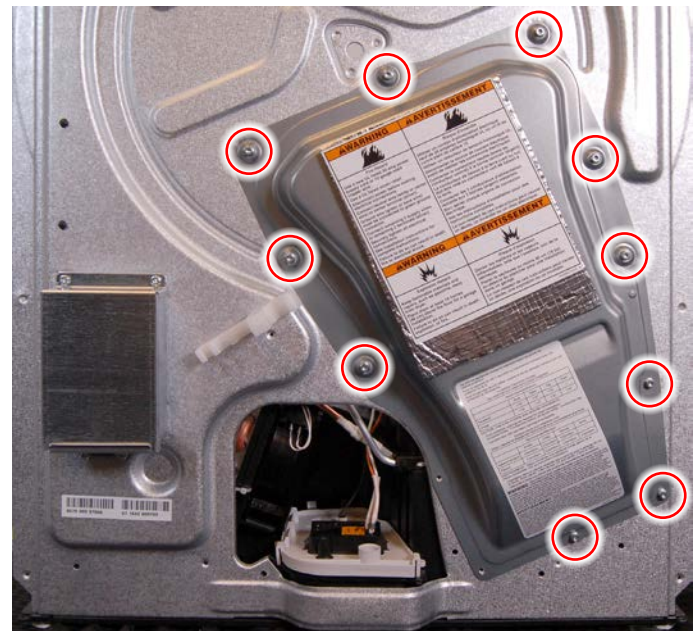

Figure 6

15. Use a T20 Torx driver to remove the three (3) screws securing the rear panel to the base assembly (as illustrated in Figure 7). Remove rear panel from base assembly.

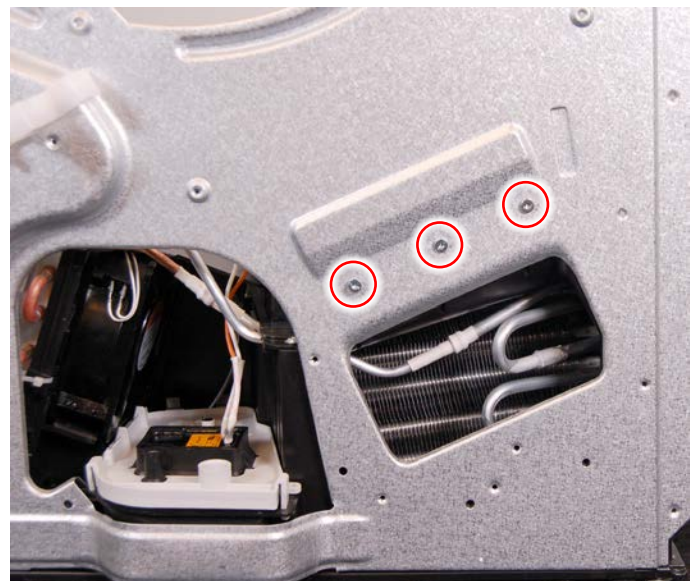

Figure 7

16. Reverse procedure to reinstall the rear panel assembly.

## Removing the Heat Pump (Base Assembly)

### **⚠ WARNING**



**Electrical Shock Hazard**  
**Disconnect power before servicing.**  
**Replace all parts and panels before operating.**  
**Failure to do so can result in death or electrical shock.**

3. Perform the procedure on page 4-9, "Remove the Side Panels" prior to performing the following steps.
4. Perform the procedure on page 4-11, "Remove the Console /User Interface" prior to performing the following steps.
5. Perform the procedure on page 4-13, "Remove the Water Tank" prior to performing the following steps.
6. Perform the procedure on page 4-17, "Remove the Front Panel" prior to performing the following steps.
7. Perform the procedure on page 4-18, "Remove the Drum" prior to performing the following steps.
8. Perform the procedure on page 4-20, "Remove the Back Panel" prior to performing the following steps.

### To Remove the Heat Pump (Base Assembly)

If the compressor or sealed system has been diagnosed faulty, it will be necessary to replace the entire base assembly.

1. Unplug dryer or disconnect power.
2. Perform the procedure on page 4-9, "Remove the Top Panel" prior to performing the following steps.

### Base Assembly Replacement

**NOTE:** The following components must be transferred from the original product base to the new service replacement base:

- Drive Motor and Blower Wheel Assembly
- Heat Exchanger Lint Filter
- Roller Supports
- Compressor Thermal Overload Protector
- Seal, Base to Rear Panel (order and replace)
- Seal, Base to Front Panel (order and replace)

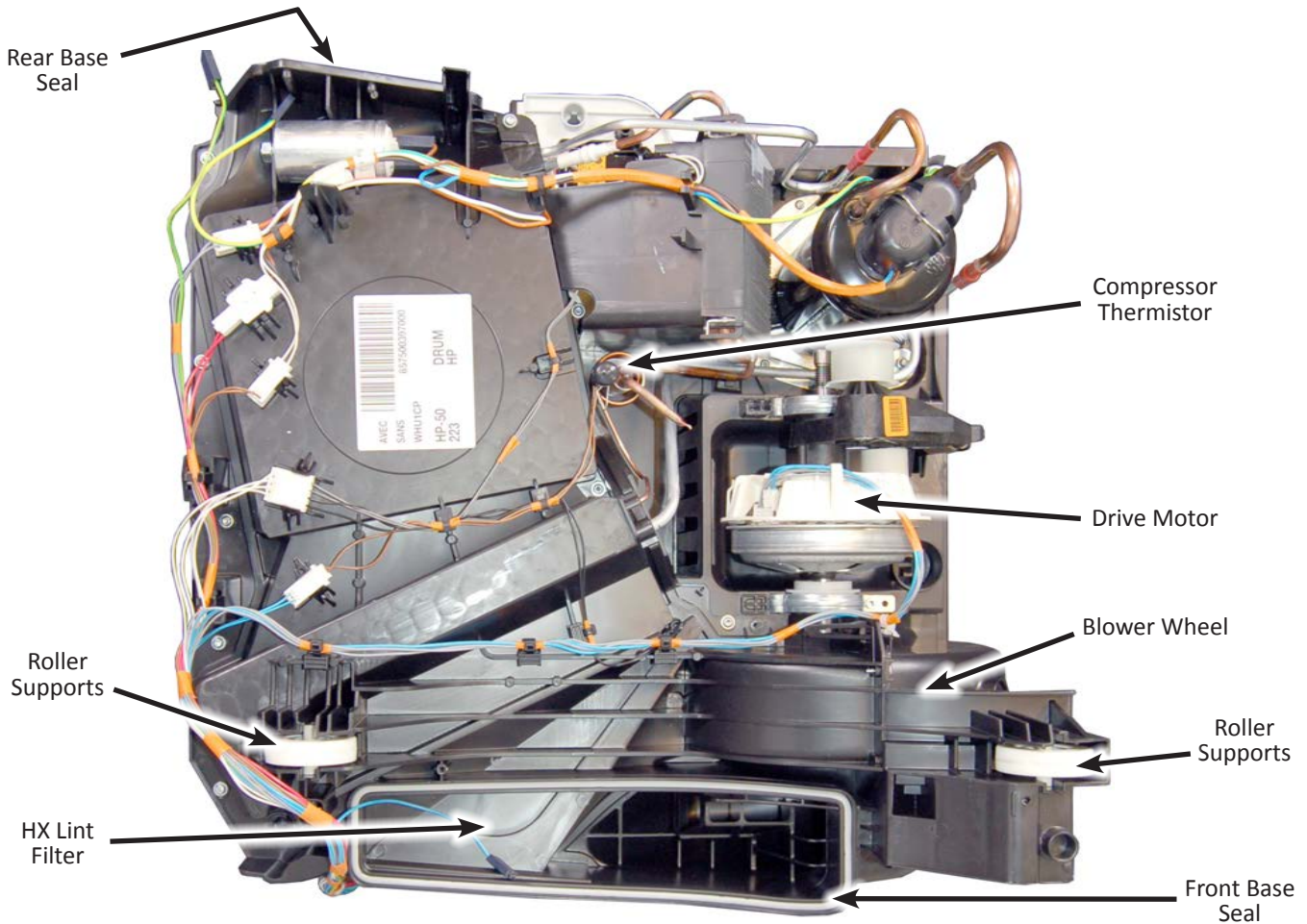

# **PRODUCT SPECIFICATIONS & WARRANTY INFORMATION SOURCES**

---

## ***IN THE UNITED STATES:***

**FOR PRODUCT SPECIFICATIONS AND WARRANTY INFORMATION CALL:  
FOR WHIRLPOOL PRODUCTS: 1-800-253-1301**

**FOR TECHNICAL ASSISTANCE WHILE AT THE CUSTOMER'S HOME CALL:  
THE TECHNICAL ASSISTANCE LINE: 1-800-832-7174**

**HAVE YOUR STORE NUMBER READY TO IDENTIFY YOU AS AN  
AUTHORIZED IN-HOME SERVICE PROFESSIONAL**

**FOR LITERATURE ORDERS (CUSTOMER EXPERIENCE CENTER):  
PHONE: 1-800-851-4605**

**FOR TECHNICAL INFORMATION AND SERVICE POINTERS:  
[www.servicematters.com](http://www.servicematters.com)**

---

## ***IN CANADA:***

**FOR PRODUCT SPECIFICATIONS AND WARRANTY INFORMATION CALL  
PHONE: 1-800-461-5681**

**FOR TECHNICAL ASSISTANCE WHILE AT THE CUSTOMER'S HOME CALL:  
THE TECHNICAL ASSISTANCE LINE: 1-800-488-4791**

**HAVE YOUR STORE NUMBER READY TO IDENTIFY YOU AS AN  
AUTHORIZED IN-HOME SERVICE PROFESSIONAL**

**Whirlpool 4.3 CU FT  
Compact Heat Pump Dryer**

**W11040040**