

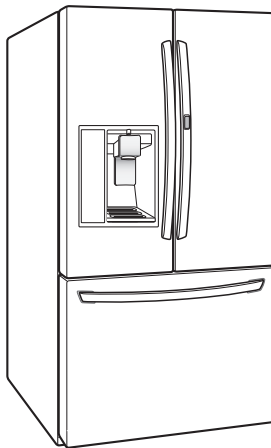

REFRIGERATOR

SERVICE MANUAL

CAUTION
BEFORE SERVICING THE UNIT,
READ THE SAFETY PRECAUTIONS IN THIS MANUAL.



MODEL : LFXS30766*

COLOR : STAINLESS(ST)

CONTENTS

SAFETY PRECAUTIONS	2
1. SPECIFICATIONS	3
2. PARTS IDENTIFICATION	4
3. DISASSEMBLY	5-24
REMOVING AND REPLACING REFRIGERATOR DOORS	5
DOOR	6
SUB,PCB	7
DOOR ALIGNMENT	8
FAN AND FAN MOTOR	8
DEFROST CONTROL ASSEMBLY	8
REFRIGERATOR LIGHT (TOP)	9
MULTI DUCT	10
DISPENSER	11
DISPLAY PCB	11
WATER BUTTON ASSEMBLY.....	11
ICE BUTTON ASSEMBLY	11
ICE CORNER DOOR REPLACEMENT	11
ICEMAKER REPLACEMENT	12
CAP DUCT MOTOR REPLACEMENT	12
HOW TO REMOVE A ICE BIN	13
HOW TO PLACE ICE BIN IN POSITION	13
HOW TO INSERT A ICE BIN	13
HOW TO REMOVE AND REINSTALL THE PULLOUT DRAWER	14-15
WATER VALVE DISASSEMBLY METHOD	16
FAN AND FAN MOTOR DISASSEMBLY METHOD	16
PULL OUT DRAWER	17
CAUTION : SEALED SYSTEM REPAIR	18
WAY VALVE SERVICE	18
HOW TO REMOVE AND REINSTALL THE HOMEBAR.....	19
HOW TO REMOVE AND REINSTALL THE HOMEBAR DOOR.....	20
HOW TO REMOVE AND REINSTALL THE DOOR FOAM ASSEMBLY, REFRIGERATOR.....	21
HOW TO REMOVE FRAME DOOR SWITCH OF DOOR FOAM.....	22
HOW TO REMOVE THE CASE HOME BAR	23
4. ADJUSTMENT	24
COMPRESSOR.....	24
5. CIRCUIT DIAGRAM	25
6. TROUBLESHOOTING	26-27
7. PCB PICTURE	28-29
8. Troubleshooting With Error Display	30-72
9. Reference	73-75
10. COMPONENT TESTING INFORMATION	76-90
11. COMPRESSOR TROUBLESHOOTING	91-105
12. ICEMAKER OPEARTING AND TROUBLE SHOOTING METHOD	106-108
13. DESCRIPTION OF FUNCTION & CIRCUIT OF MICOM	109-111

SAFETY PRECAUTIONS

Please read the following instructions before servicing your refrigerator.

1. Unplug the power before handling any elctrical componets.
2. Check the rated current, voltage, and capacity.
3. Take caution not to get water near any electrical components.
4. Use exact replacement parts.
5. Remove any objects from the top prior to tilting the product.

1. SPECIFICATIONS

1-1 LFXS30766*

29.6 cu.ft.

ITEMS	SPECIFICATIONS
DOOR DESIGN	Side Rounded
DIMENSIONS (inches)	35 3/4 X 36 1/4 X 70 1/4 (WXDXH) 29.6cu.ft.
NET WEIGHT (pounds)	160kg (353lb)
COOLING SYSTEM	Fan Cooling
TEMPERATURE CONTROL	Micom Control
DEFROSTING SYSTEM	Full Automatic Heater Defrost
DOOR FINISH	PCM, VCM, Stainless
HANDLE TYPE	Bar
INNER CASE	ABS Resin
INSULATION	Polyurethane Foam

ITEMS	SPECIFICATIONS	
VEGETABLE TRAY	Clear Drawer Type	
COMPRESSOR	Linear	
EVAPORATOR	Fin Tube Type	
CONDENSER	Spiral Condenser	
REFRIGERANT	R-134a (135 g)	
LUBRICATING OIL	ISO10 (280 ml)	
DEFROSTING DEVICE	SHEATH HEATER	
LAMP	REFRIGERATOR	LED Module
	FREEZER	LED Module

DIMENSIONS

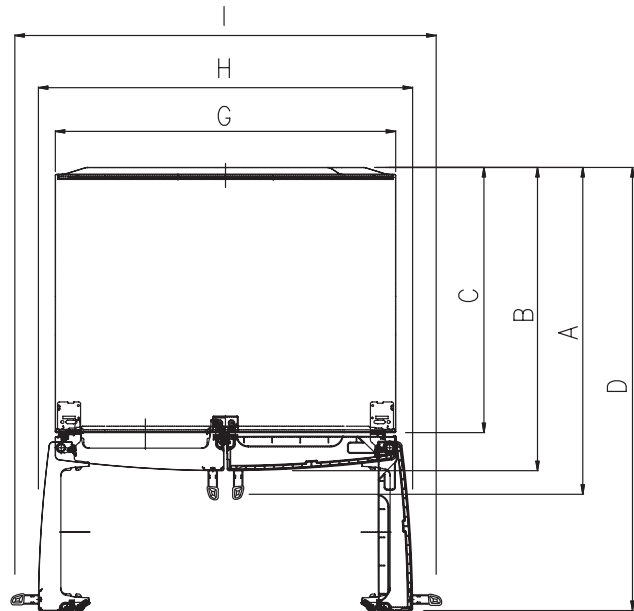
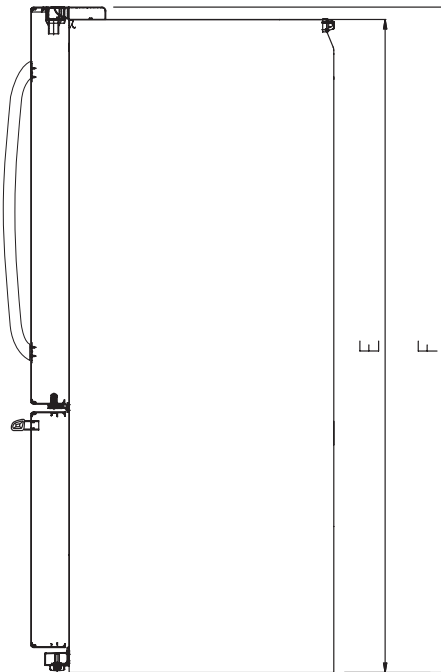

Description		LFXS30726*
Depth w/ Handles	A	36 1/4 in
Depth w/o Handles	B	33 3/4 in
Depth w/o Door	C	29 1/2 in
Depth (Total with Door Open)	D	48 1/8 in
Height to Top of Case	E	68 7/8 in
Height to Top of Door Hinge	F	70 1/4 in
Width	G	35 3/4 in
Width (door open 90 deg. w/o handle)	H	40 in
Width (door open 90 deg. w/ handle)	I	44 1/4 in

2. PARTS IDENTIFICATION

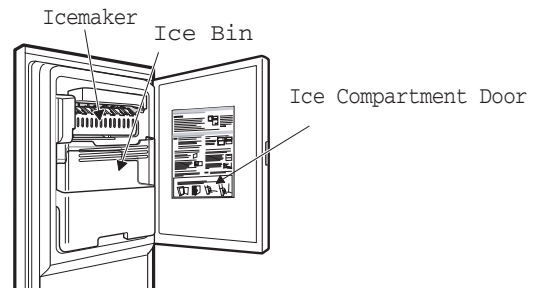
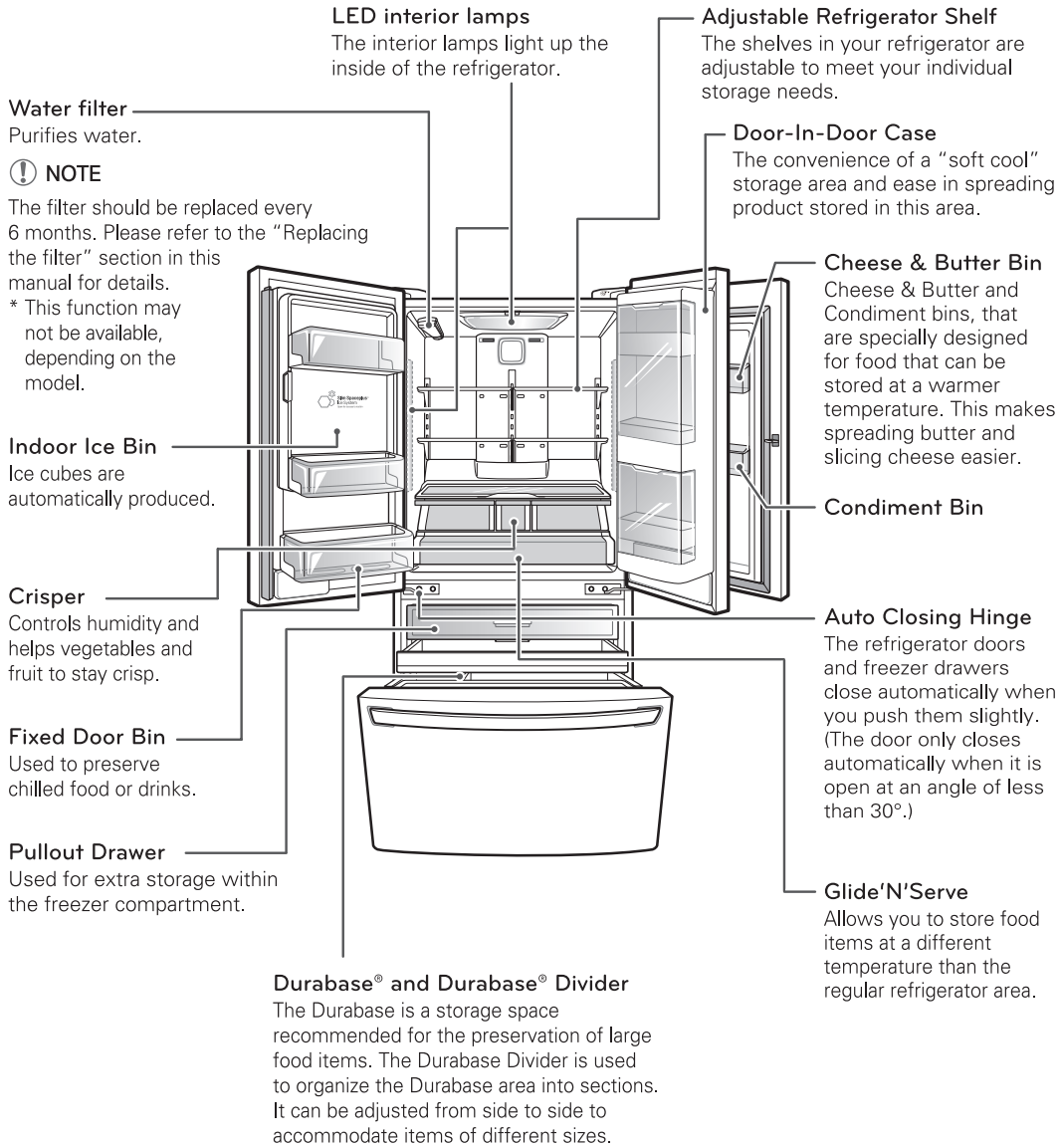

3. DISASSEMBLY

3-1 REMOVING AND REPLACING REFRIGERATOR DOORS

Removing Refrigerator Door

▲ **CAUTION:** Before you begin, unplug the refrigerator. Remove food and bins from doors.

Left Door -FIG. 2

1. Disconnect water supply tube by pushing back on the disconnect ring (3).-FIG. 1
2. Open door. Loosen top hinge cover screw (1).
- Use flat tip screwdriver to pry back hooks on front underside of cover (2). Lift up cover.
3. Disconnect door switch wire harness and remove the cover.
4. Pull out the tube.
5. Disconnect all 3 wiring harnesses (4). Remove the grounding screw (5).
6. Rotate hinge lever (6) counterclockwise. Lift top hinge (7) free of hinge lever latch (8).

▲ **CAUTION:** When lifting hinge free from the latch, be careful that door does not fall forward.

7. Lift door from middle hinge pin and remove door.
8. Place the door with the insides facing up, on a not scratch surface.

Right Door -FIG. 3

1. Open the door, remove 1 screw on the top of the hinge cover. Loosen top hinge cover screw (1). Lift up cover (2).
2. Disconnect door switch wire harness and remove the cover.
3. Rotate hinge lever (3) clockwise. Lift top hinge (4) free of hinge lever latch (5).
4. Lift door from middle hinge pin and remove door.

▲ **CAUTION:** When lifting hinge free from the latch, be careful that the door does not fall forward.

5. Place the door with the insides facing up, on a not scratch surface.

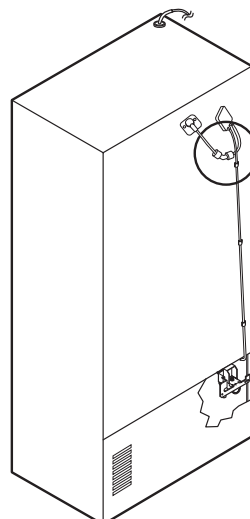
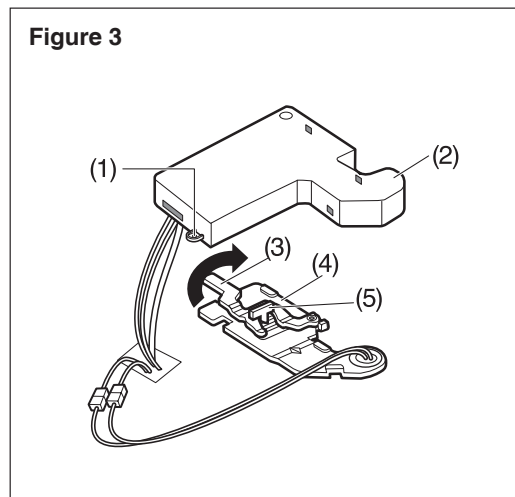
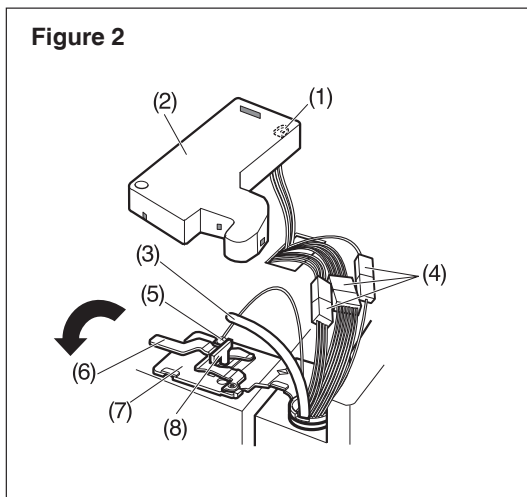
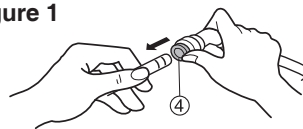
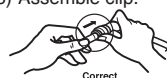

Figure 1



- 1) Insert the tube until you can see only one of the lines printed on the tube.
- 2) After inserting, pull the tube to ascertain that it is secure.
- 3) Assemble clip.



3-2 DOOR

Mullion Removal

1. Remove 2 screws.

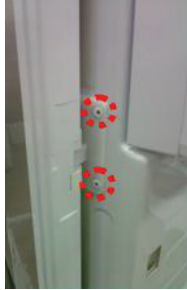

2. Lift mullion up carefully.



3. Disconnect wire harness.



Door Gasket Removal

1. Remove gasket

Remove the gasket from gasket channel at doorliner as shown in the illustration below.

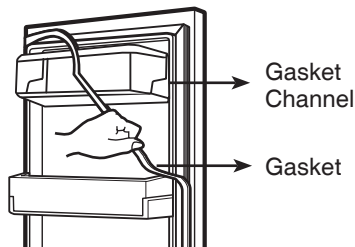

Door Gasket Replacement

1. Insert gasket into channel

Insert and press gasket into channels at doorliner.

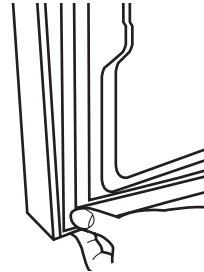

Mullion Replacement

1. Connect wire harness.



2. Insert mullion into channel.

Insert the mullion into channel at door as shown below.



3. Assemble 2 screws.

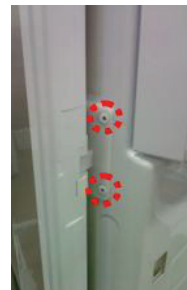

3-3 Sub PCB For Working Dispenser

● Sub,PCB Removal

1. Remove 1 Screw.



2. Lift Sub PCB up carefully.



3. Reverse the Suc PCB cover.



4. Disconnect capacitor housing.



5. Disconnect wire harness.



● Sub,PCB Replacement

1. Reverse the Sub PCB cover.



2. Connect wire harness.

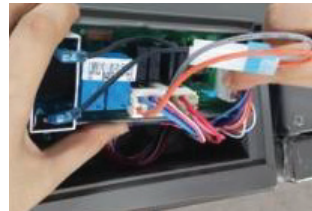

3. Connect the capacitor housing.



4. Insert the Sub PCB sideling.



5. Assemble 1 screw.



3-4 Door Alignment

If the level of refrigerator doors is uneven, follow the instructions below to align the doors:
Turn the leveling legs (CW) to raise or (CCW) to lower the height of the front of the refrigerator by using flat blade screw driver or 11/32" wrench. Use the wrench (Included with the Owners Manual) to adjust the bolt in the door hinge to adjust the height. (CW to raise or CCW to lower the height.)

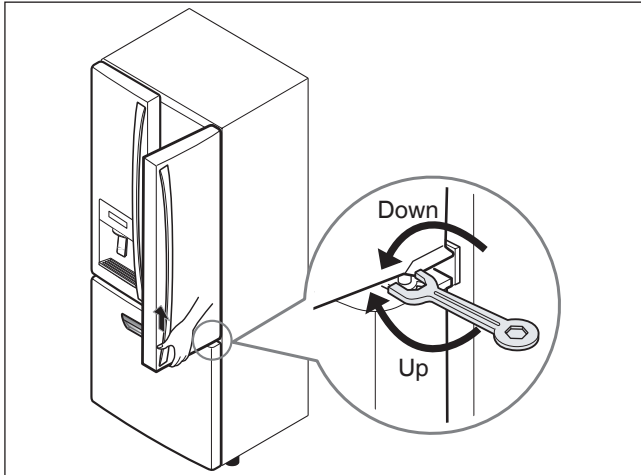

3-5 FAN AND FAN MOTOR

1. Remove the freezer drawer.
2. Remove the plastic guide for slides on left side by unscrewing phillips head screws.
3. Remove the grille assembly by removing four screws and pulling the grille assembly forward.
4. Remove the Fan Motor assembly by loosening 3 screws and disassembling the shroud.
5. Pull out the fan and separate the Fan Motor and Bracket Motor.

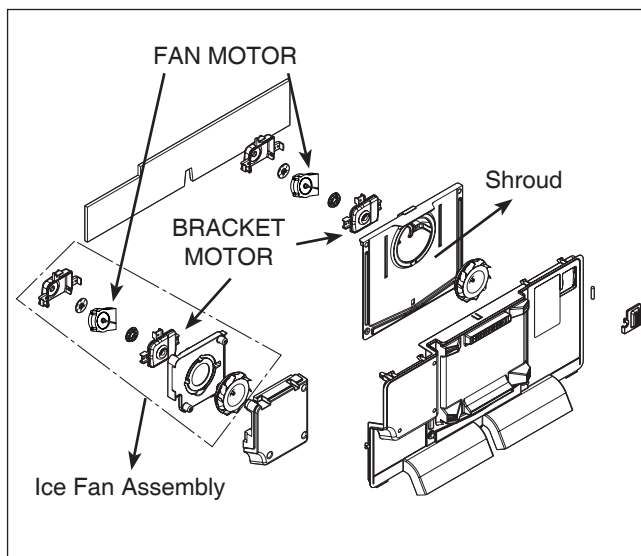

* Ice Fan Assembly Replacement

- 1) Remove the plastic guide for slides on left side by unscrewing phillips head screws.
- 2) Pull out the cover sensor to disassemble by using tools shown in the figure.
- 3) Pull out the cover grille to disassemble by using tools shown in the figure.
- 4) Put your hand into the inside of grille to disassemble shown in the figure.
- 5) Disconnect wire harness of the grille assembly.
- 6) Remove the Ice fan assembly by loosening all screws.



(1)



(2)



(3)



(4)



(5)



(6)

3-6 DEFROST CONTROL ASSEMBLY

Defrost Control assembly consists of Defrost Sensor and FUSE-M.

The Defrost Sensor works to defrost automatically. It is attached to the metal side of the Evaporator and senses its temperature. At 46F(8°C), it turns the Defrost Heater off. Fuse-M is a safety device for preventing over-heating of the Heater when defrosting.

1. Pull out the grille assembly. (Figure 1)
2. Separate the connector with the Defrost Control assembly and replace the Defrost Control assembly after cutting the Tie Wrap. (Figure 2)

GRILLE ASSEMBLY

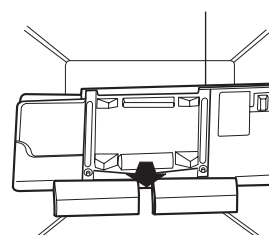

DEFROST-CONTROL ASSEMBLY

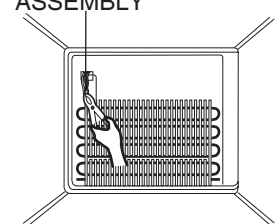

3-7 Refrigerator Light (Top)

Unplug Refrigerator, or disconnect power at the circuit breaker.

If necessary, remove top shelf or shelves.

3-7-1 Refrigerator Compartment Lamp

- 1) Release 2 screws.
- 2) Hold both ends with your both hands and pull it downward to remove it.



- 3) To remove the case lamp and cover lamp, release another 2 screws as following picture.



- 4) Use a flat blade screwdriver as shown below to remove the cover lamp.



- 5) To remove the LED Assembly, open the Hook part to pull it out as shown in the following picture.



Cover, lamp

LED, Assembly

Case, lamp

3-7-2 Refrigerator Light (Side)

1. Unplug refrigerator power cord from electric outlet.
2. Put flat screwdriver into sevice hole and remove cover of refrigerator light.

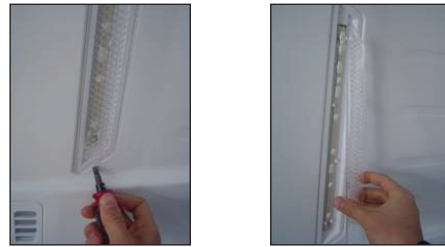

3. Remove the LED assembly from connector.



4. Replace LED assembly.

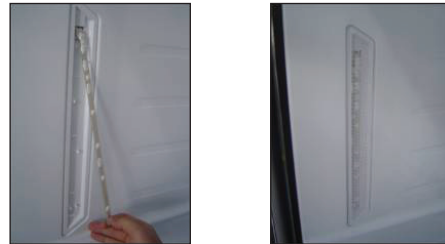

5. Assemble the cover in reverse order.

3-7-3 Cap Decor LED LAMP(Bottom)

1. Unplug refrigerator power cord from electric outlet.
2. Open the refrigerator door to need diassembly.
3. Put flat screwdriver into service hole, remove the cover of cap decor LED LAMP.



4. Remove the LED assembly from connector.



5. Replace LED assembly.



6. Assembly the cover in reverse order.

3-8 MULTI DUCT

1. Remove 2 screws and guide rail.



2. Remove the upper and lower Caps by using a flat screwdriver and remove 2 screws as shown figure.



3. Disconnect the lead wire on the bottom position



4. Grip both side of multi duct, pull it out.



3-9 DISPENSER



1) Pull out the drain



2) Holding the inner side of the dispenser pull forward to remove.



3) Remove the lead wire.

▲ CAUTION: When replacing the dispenser cover make sure the lead wire does NOT come off and the water line is not pinched by the dispenser.



3-10 DISPLAY PCB

As shown below, remove the Display PCB fixing screws.



Display PCB

3-11 ICE BUTTON ASSEMBLY

- 1) Remove the 1 screw holding the lever.
- 2) Remove the spring from the hook.
- 3) Push and pull on the tab to remove.



Button Lever

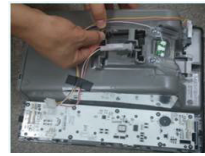

3-12 WATER BUTTON ASSEMBLY

- 1) Remove 3 screws holding the Funnel and Button Lever
- 2) Remove the Funnel and Button Lever
- 3) Push the hook

Button Lever

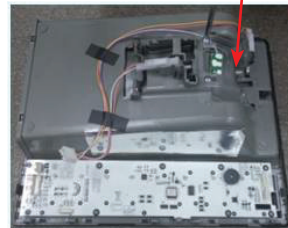

3-13 ICE CORNER DOOR REPLACEMENT

- 1) Loosen the front screw as shown in the picture.
- 2) Remove the Cover Home Bar as shown in the picture.



Cover Home Bar

- 3) Lift up the hinge with one hand.
- 4) Pull out the Ice Corner Door with the other hand.



hinge

3-14 Icemaker replacement

1) Remove 3 screws marked in the picture below.

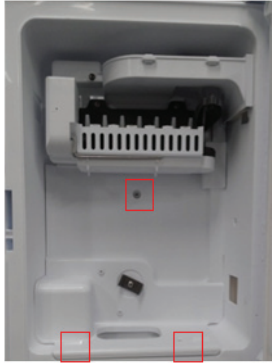

2) Grasp the bottom of motor cover assembly and pull it out slowly to remove.



3) Disconnect wire harness from wall of compartment.

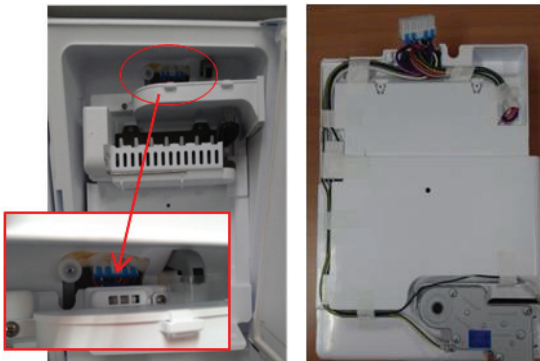

3-15 CAP DUCT MOTOR REPLACEMENT

1) Separate the Housing of the Cap Duct Motor.



2) Unscrew 3 screws to disassemble the motor.



3) When replacing the motor, check the position of the door duct and the link for proper fit.

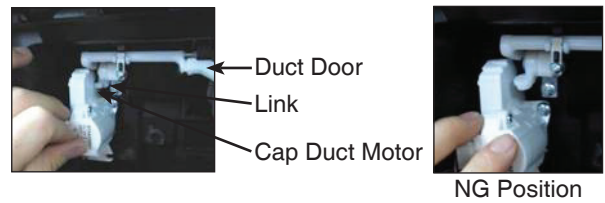

4) Insert 3 screws.

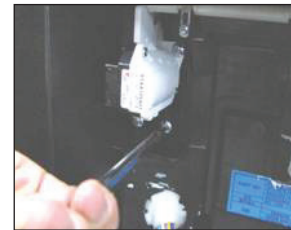

5) Push housing aside.



3-16 HOW TO REMOVE ICE BIN

1) Grip the handles, as shown in the picture.

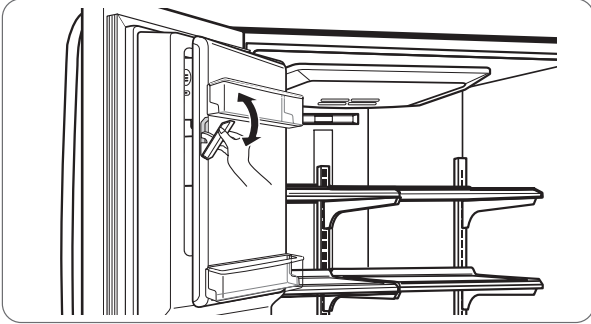

2) Lift the lower part slightly.

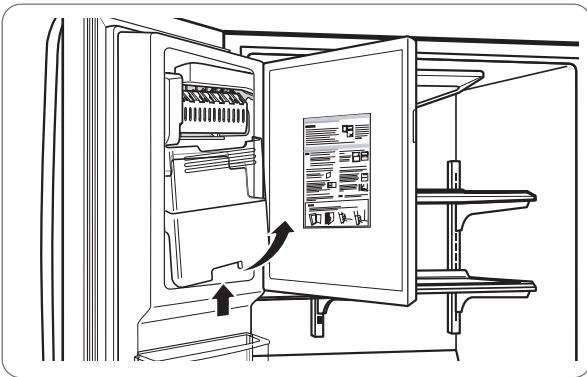

3) Take the Ice Bin out slowly.

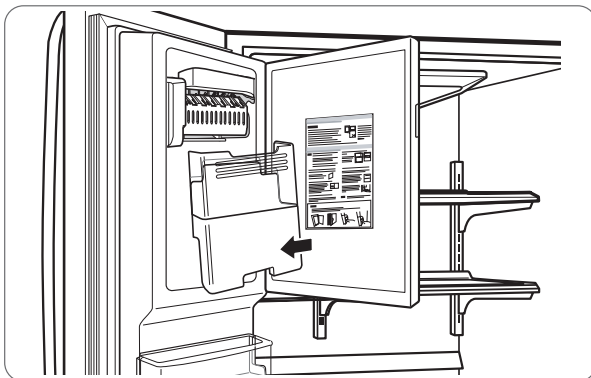

3-17 HOW TO PLACE ICE BIN IN POSITION

1) Insert the Ice Bin, slightly tilting it to avoid touching the icemaker. (Especially, Ice-Detecting Sensor)

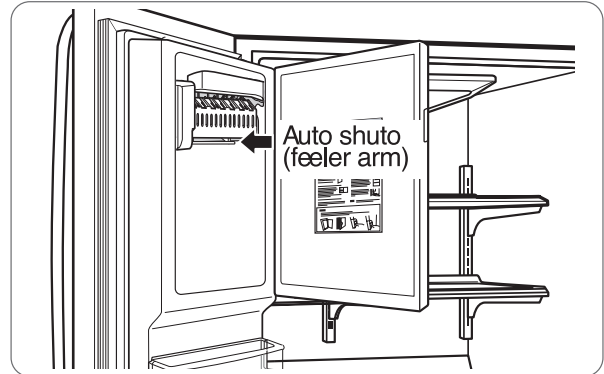

Note) Before remove ice bin, put on clean gloves for keeping clean ice bin.

3-18 HOW TO REMOVE AND REINSTALL THE PULLOUT DRAWER

3-18-1 Follow Steps to Remove

Step 1) Open the freezer door.



Step 2) Remove the lower basket.



Step 3) Remove the two screws from the guide rails (one from each side).

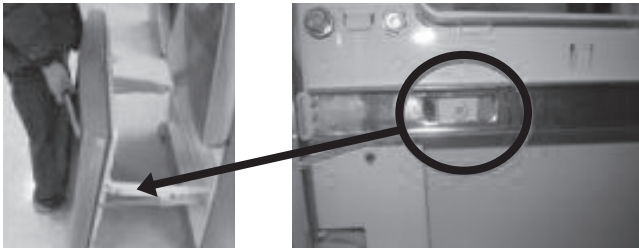

Step 4) Removal of the freezer door is done by lifting clear of the rail support.
Fully extend both rails.



Step 5) Remove only 1 screw of gearice, and disassemble the bar and gearice



Step 6) Remove 2 screws of both side of supporter covers tv and disassemble the supporter cover tv.



3-18-2 Follow Steps to Reinstall

Step 1) Insert both side of supporter cover tv into connector rails, and then screw them.



Step 2) Assemble a bar and gear ice with screw. Push the otherside of the gear to inside of the bar.



Step 3) Put gear ice assembled with the bar by screw into connector rail's hole.

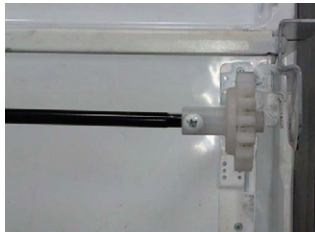

Step 4) Insert opposite gear ice into connector rail and screw them



Step 5) The rail system will align itself by pushing the rails all the way into the freezer section. Pull the rails back out to full extension.

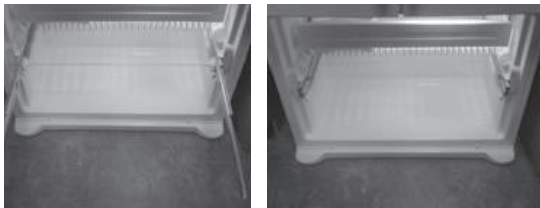

Step 6) Reinstall the freezer door by inserting the rail tabs into the guide rail.



Step 7) Reinstall the two screws into the guide rails (one from each side).

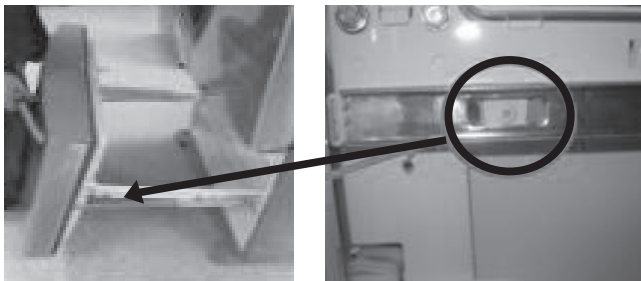

Step 8) Reinstall the lower basket, and close the freezer door.



3-19 WATER VALVE DISASSEMBLY METHOD

- 1) Turn off the water to unit. Remove the waterline from the valve.

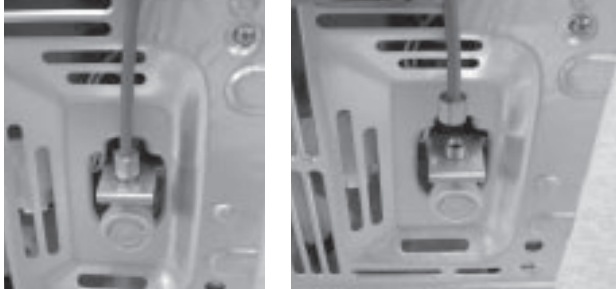

- 2) Remove cover and 1 screw from the valve.

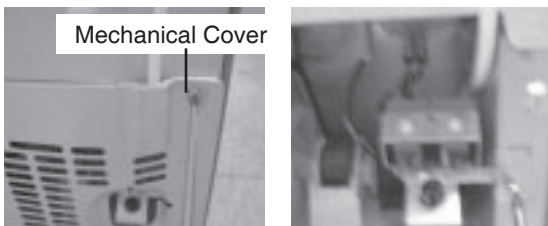

- 3) Separate the housing and remove the valve.



- 4) Remove the clip, and press the collet to separate the tube from the connector. Note: there maybe some water in the line.

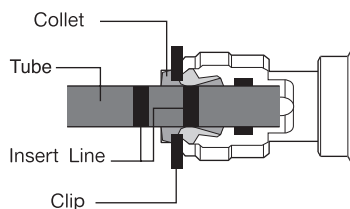

3-20 FAN MOTOR ASSEMBLY AND DISASSEMBLY METHOD

- 1) Remove screws for the Drain Pipe Assembly and the 1 connected to the Motor Cover.

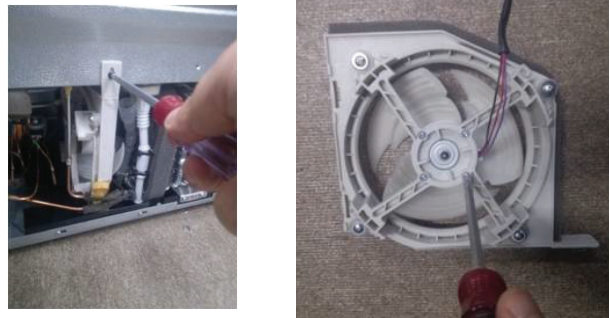

- 2) Remove the screw from shroud and Separate the Fan motor assembly and Shroud.



Assemble in reverse order. Taking care to avoid.

1. Do not to bend the tube during assembly.
2. Press the Water Dispenser button letting water pour out, this checks for any leaks in the tube connection, this may vary depending on the water pressure (about 2 minutes.).

3-21 PULL OUT DRAWER

Top Drawer

1. Use a flat blade screwdriver to push the tab in on the left rail and push the tab on the right rail in with your finger. Once the tabs have been pushed in, you can lift the tray up and out.

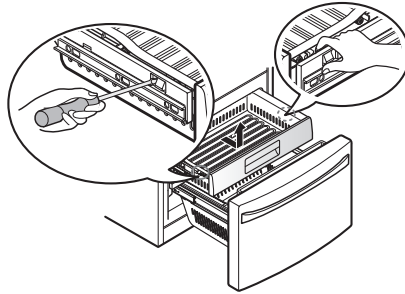

2. Pull both rails out to the full extension and insert the back of the tray into both rails. Then set the front of the tray into the rail and push it until you hear it click into place.

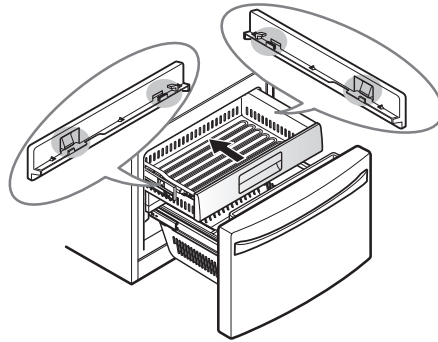

Middle Drawer

1. To remove the middle drawer.
Pull the drawer out to full extension. Lift the front of the drawer up, then pull it straight out.

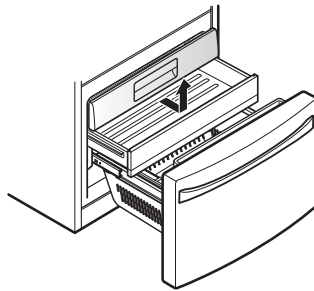

2. To install, slightly tilt up the front and insert the drawer into the frame and push it back into push it back place.

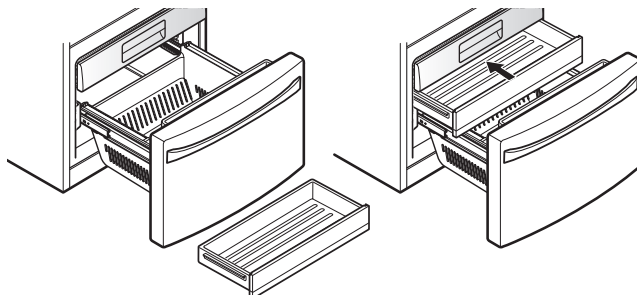

3-22 CAUTION : Sealed System Repair

Before making a sealed system repair : Start with the power cord unplugged from the outlet. Plug in the power cord and between 6 and 12 seconds after it has been pugged in, unplug it from the power source. this will allow both sides of the 3 way valve to be opened to allow for proper evacuation.

3-23 3 Way Valve Service

The 3 way valve has plastic parts inside, so always wrap it with a wet cloth before servicing when using a torch.

- 1) Always replace the 3 way valve if there is a leak at any one of the 3 tubes coming from it.
- 2) Service in replacement of valve (valve failure) Perform service in the same method as above.

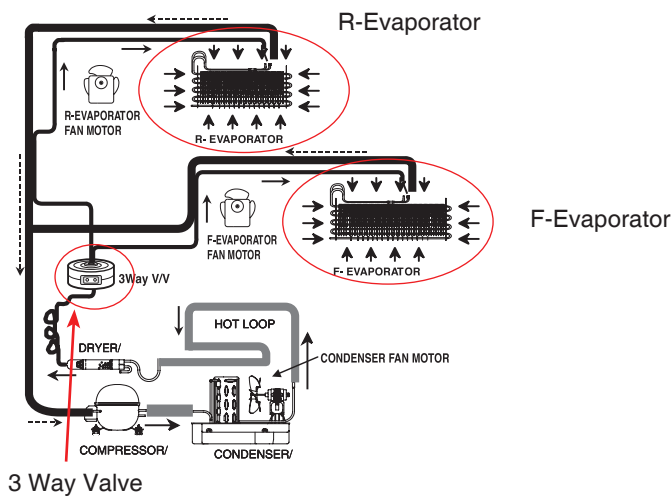

Whole picture of refrigerator

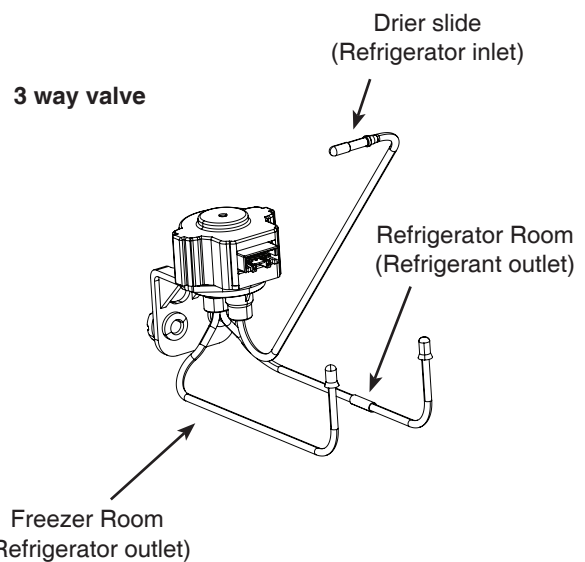
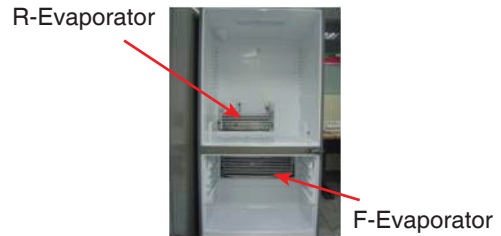

Note : To service sealed system, follow the directions in 3-22 and 3-23 above. Then service is the same as a single evaporator system.

3-24 HOW TO REMOVE AND REINSTALL THE HOME BAR

3-24-1 CASE ASSEMBLY, HOME BAR

The Home Bar is removable for easy cleaning and adjustment.

1. To remove the Home Bar, Slopingly lifts the Home Bar up and pulls straight out.

2. To replace the Home Bar, Slopingly slides it in above the desired support and push down until it snaps into place.

NOTE : Some Home Bar may vary in appearance and will only fit in one location.

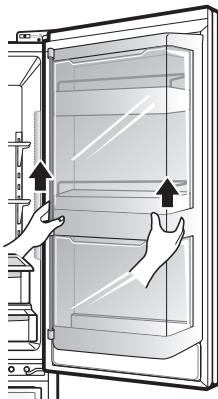

3-24-2 DOOR BASKET OF HOME BAR DOOR

The Door Baskets are removable for easy cleaning and adjustment.

1. To remove the Door Baskets, simply lifts the Door Baskets up and pulls straight out.

2. To replace the Door Baskets, slides it in above the desired support and push down until it snaps into place.

NOTE : Some Door Baskets may vary in appearance and will only fit in one location.

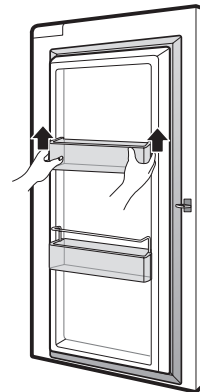

3-24-3 DOOR BASKET OF HOME BAR

The Door Baskets of Homebar are removable for easy cleaning and adjustment.

1. To remove the Door Baskets of Homebar, simply lifts the Door Baskets of Homebar up and pulls straight out.

2. To replace the Door Baskets of Homebar, slides it in above the desired support and push down until it snaps into place.

NOTE : Some Door Baskets of Homebar may vary in appearance and will only fit in one location.

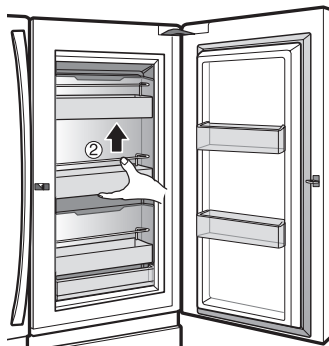
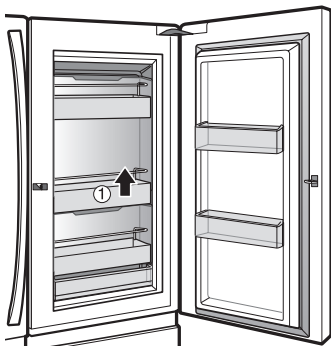

3-24-4 COVER FRONT

The Cover Front is removable for easy cleaning and adjustment.

1. To remove the Cover Front, simply lifts the basket door up and pulls slopingly out.
2. Remove two screws of The Cover Front and pull slopingly straight out.

NOTE : To replace the Cover Front and basket door, Slide them in above desired support and push down until them snaps into place.



3-25 HOW TO REMOVE AND REINSTALL THE HOMEBAR DOOR

1. Remove three Screws on the Top of Frame Door.



2. Pull Frame Door. up and out.



3-26 HOW TO REMOVE AND REINSTALL THE DOOR FOAM ASSEMBLY, REFRIGERATOR

1. Remove the Screw of Right Hinge Cover.

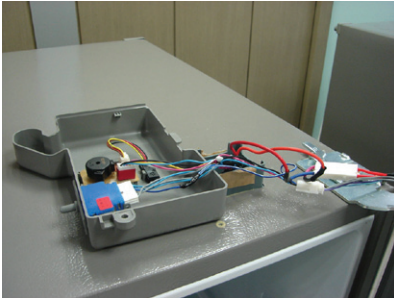

2. Remove two Wire connectors.

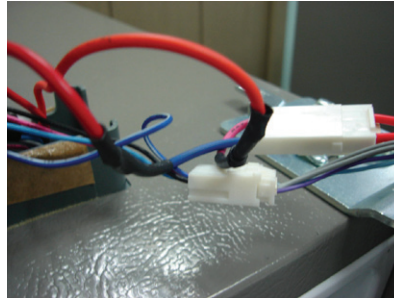

3. Rotate the hinge lever clockwise.



4. Separate the Home Bar.



5. Pull THE DOOR FOAM ASSEMBLY, REFRIGERATOR up and out.



3-27 HOW TO REMOVE FRAME DOOR SWITCH OF DOOR FOAM

1. Remove screws on hinge assebmly, Upper



2. Separate the Cap,decor on the frame door.



3. Press the hook of door switch,
Then pushes it outward.



4. Remove a wire connector for change.



3-28 HOW TO REMOVE THE HOME BAR DOOR

1. Remove the screw located on the top of hinge.



2. Remove the cap hinge(upper)



3. Remove the bar by pushing it up from the bottom through the SVC hole (bottom hinge).

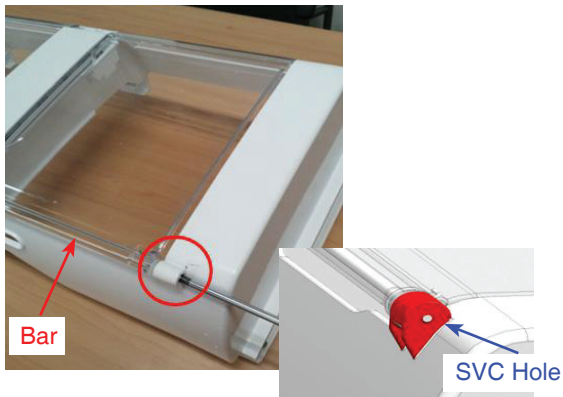

4. Pull out the bar through the top hinge.

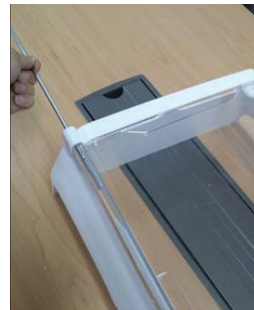

5. Separate the Cover.



4. ADJUSTMENT

4-1 COMPRESSOR

4-1-1 Role

The compressor intakes low temperature and low pressure gas from the evaporator of the refrigerator and compresses this gas to high-temperature and high-pressure gas. It then delivers the gas to the condenser.

4-1-2 Note for Usage

- (1) Be careful not to allow over-voltage and over-current.
- (2) Do not drop or handle carelessly.
- (3) Keep away from any liquid.
If liquid such as oil or water enters the Cover PTC Compressor may fail due to breakdown of their insulating capabilities.
- (4) Always use the Parts designed for the compressor and make sure it is properly attached to the compressor. Parts may appear physically identical but could have different electrical ratings. Replace parts by part number and model number. Use only approved substitute parts.

4-1-3 Remove the cover PTC



(1) Remove the Cover Back M/C



(2) Remove two screws on comp base



- (3) Use a L-shaped flap tool to pry off the cover
- (4) Assembly in reverse order of disassembly

4-2-3 Compressor protection logic

Since linear Comp conducts linear reciprocating motion, we have protection logic for compressor, motor and PCB as the below.

- Stroke Trip
During the operation, if stroke is above the target value, decrease the target volt by 3V.
- Current Trip
Current trip is set in order to protect compressor mechanical part and drive from the overcurrent that might arise during the operation.
Check the current for every 416.7us and if the Trip exceeds 1.86Arms more than three times at Comp ON, forcibly stop and restart six minutes later.
- Lock Piston Trip
If stroke is under 5mm even if the current is more than 14Arms, Take it as 'piston lock' and restart after 2'30" of Comp OFF. Check the current and stroke for every 416.7us and if the condition fits more than three times at Comp ON, the Trip occurs.
- IPM fault Trip
It occurs if FO signal received from IPM is LOW. For every 416.7us, check whether FO signal is LOW. The trip occurs if it is found three times during the five periods(83ms).

5. CIRCUIT DIAGRAM

CIRCUIT DIAGRAMS

*EARTH PART, DUCT HEATER, PLUG TYPE AND COMEARTH PART, FUSE ON CIRCUIT DIAGRAM ARE SUBJECT TO CHANGE IN DIFFERENT LOCALITIES AND MODEL TYPE.

-i- : OPTIONAL

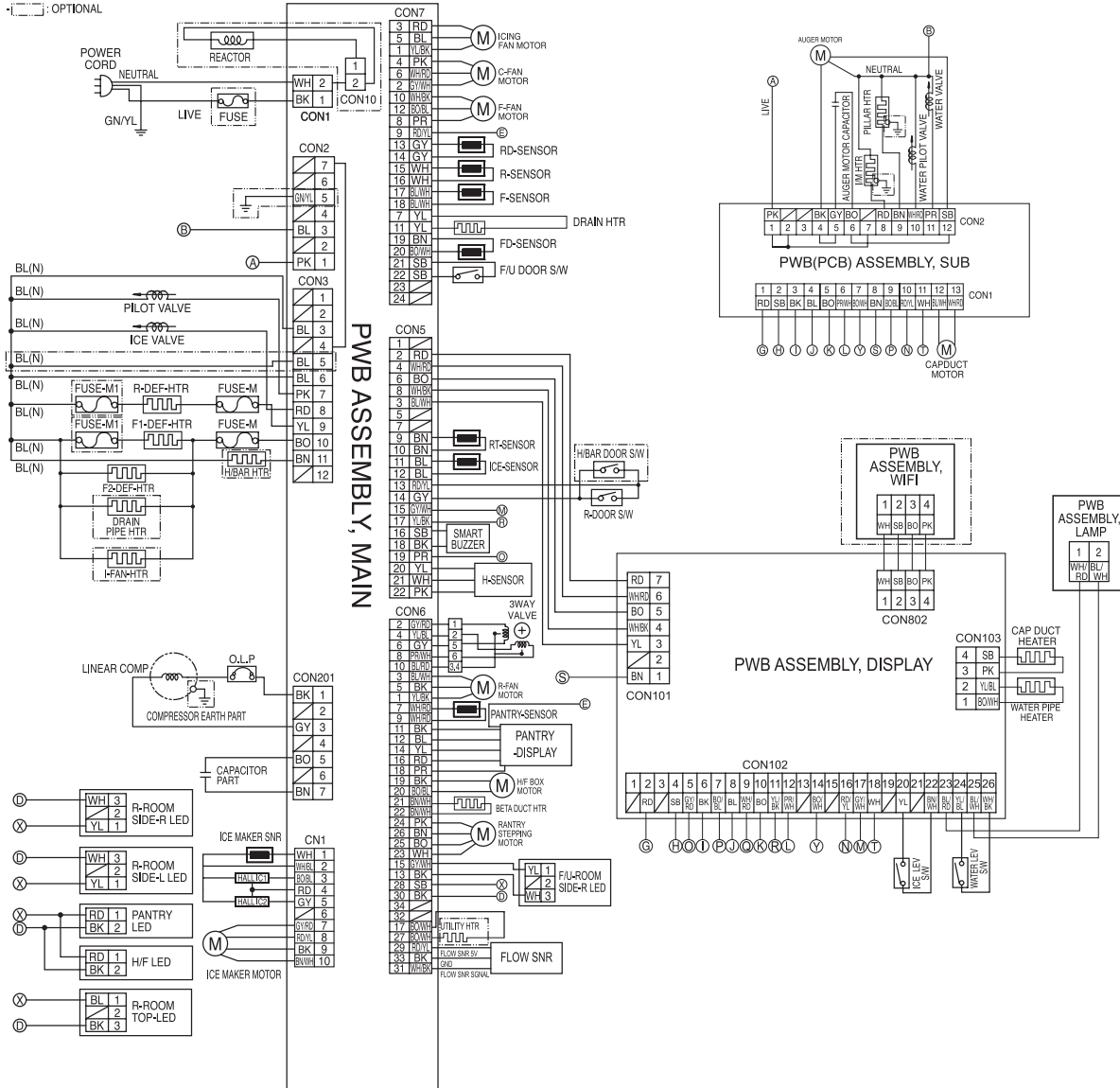

BK(BLACK) : NOIR BL(BLUE) : BLEU BNB(BROWN) : MARRON BO(BRIGHT ORANGE) : ORANGE BRILLANT GY(GRAY) : GRIS YL/BL(YELLOW/BLUE) : JAUNE/BLEU WH/BK(WHITE/BLACK) : LANC/NOIR
 YL(YELLOW) : JAUNE RD(RED) : ROUGE GN(GREEN) : VERT BL/WH(BLUE/WHITE) : BLEU/BLANC WH(WHITE) : BLANC GY/RD(GRAY/RED) : GRIS/ROUGE RD/WH(RED/WHITE) : ROUGE/BLANC
 SB(SKY BLUE) : CIEL BLEU PK(PINK) : ROSE GN/YL(GREEN/YELLOW) : VERT/JAUNE PR(PURPLE) : PURPLE BO/WH(BRIGHT ORANGE/WHITE) : ORANGE BRILLANT/BLANC
 WH/RD(WHITE/RED) : BLANC/ROUGE BN/WH(BROWN/WHITE) : MARRON/BLANC RD/YL(RED/YELLOW) : ROUGE/JAUNE
 YL/BK(YELLOW/BLACK) : JAUNE/NOIR PR/WH(PURPLE/WHITE) : VIOLET/BLANC BL/RD(BLUE/RED) : BLEU/ROUGE
 GY/WH(GRAY/WHITE) : GRIS /BLANC BO/BL(BRIGHT ORANGE/BLUE) : ORANGE BRILLANT/BLEU GY/RD(GRAY/RED)/GRIS/ROUGE

6. TROUBLESHOOTING

6-1 Error Code Summary

▲ WARNING: When checking Resistance values, make sure to turn off the power, and wait for the voltage to discharge.

NOTE) Within 3 hours after the error : Press the Ice Plus button and Freezer button simultaneously. All errors, except for "E rt", "E SS", "E HS", "E IS(except for icing Sensor)", "E gF", "E It", "E Od" error, are displayed. "E IS" which is displayed without input of user is the error of icing Sensor.

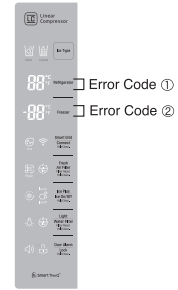

NO	Error Detection Category	Error Display		Error Generation Factors	Remark
		Refrigerator Temperature (Error code ①)	Freezer Temperature (Error code ②)		
1	Normality			None	Normal operation of Display
2	Freezer Sensor Error	E	FS	Short or Disconnection of Freezer Sensor	Check Each sensor and its Connector.
3	Refrigerator Sensor Error	E	rS	Short or Disconnection of Refrigerator Sensor	
4	Freezer Defrost Sensor Error	F	dS	Short or Disconnection Of Defrost Sensor	
5	Refrigerator Defrost Sensor Error	r	dS	Short or Disconnection Of Defrost Sensor	
6	Humidity Sensor Error	E	HS	Short or Disconnection Of Humidity	
7	Icing Sensor Error	E	IS	Short or disconnection of the sensor about Ice maker (Icing sensor, Ice maker sensor)	
8	Pantry sensor error	E	SS	Short or Disconnection of Pantry Sensor	
9	Room Temp Sensor Error	E	rt	Short or Disconnectoin of Room temp.sensor	
10	Ice maker kit defect	E	It	Other Electric system error such as motor, gear, Hall IC, operation circuit within I/M kit	
11	Flow Meter(Sensor) Defect	E	gF	Error of flow motor or water input or low water pressure	Error of flow meter or water input or low water pressure or flow meter connection
12	Freezer Defrosting Error	F	dH	Even though it is passed 80Minute since then Defrosting, If Defrosting sensor is not Over 41°F (5°C), it is caused	Temperature Fuse Disconnection Heater Disconnection, DRAIN Jam, Poor Relay for Heater
13	Refrigerator Defrosting Error	r	dH	Even though it is passed 80Minute since then Defrosting, If Defrosting sensor is not Over 41°F(5°C) it is caused	
14	Abnormality of BLDC FAN Motor for Ice Making	E	IF	It is caused when feedback signal isn't over 65 seconds during BLDC FAN motor operating	Poor BLDC Motor connection, DRIVE IC, and TR
15	Abnormality of BLDC FAN Motor for Freezer	E	FF	It is caused when feedback signal isn't over 65 seconds during BLDC FAN motor operating	Poor BLDC Motor connection, DRIVE IC, and TR

NO	Error Detection Category	Error Display		Error Generation Factors	Remark
		Refrigerator Temperature (Error code ①)	Freezer Temperature (Error code ②)		
16	Abnormality of BLDC FAN MOTOR For Refrigerator	E	rF	It is caused when feedback signal isn't over 65 seconds during BLDC FAN motor operating	Poor BLDC Motor connection, DRIVE IC, and TR
17	Abnormality of BLDC FAN Motor for Mechanic Room	E	CF	It is caused when feedback signal isn't over 65 seconds during BLDC FAN motor operating	Poor BLDC Motor connection, DRIVE IC, and TR
18	Communication Error	E	CO	Communication Error between Micom of Main PCB and Display Micom	Poor Communication connection, Poor TR of Transmitter and Receiver Tx/Rx between display and main board.
19	WiFi Modem Error	E	Od	Error of WiFi Modem or Communication Error between Micom of Display PCB and WiFi Modem	Error of WiFi Modem or Poor Communication connection, Poor TR of Tx/Rx between display and WiFi Modem.

7. PCB Picture

7-1. Main PCB

(P/N : EBR789406)

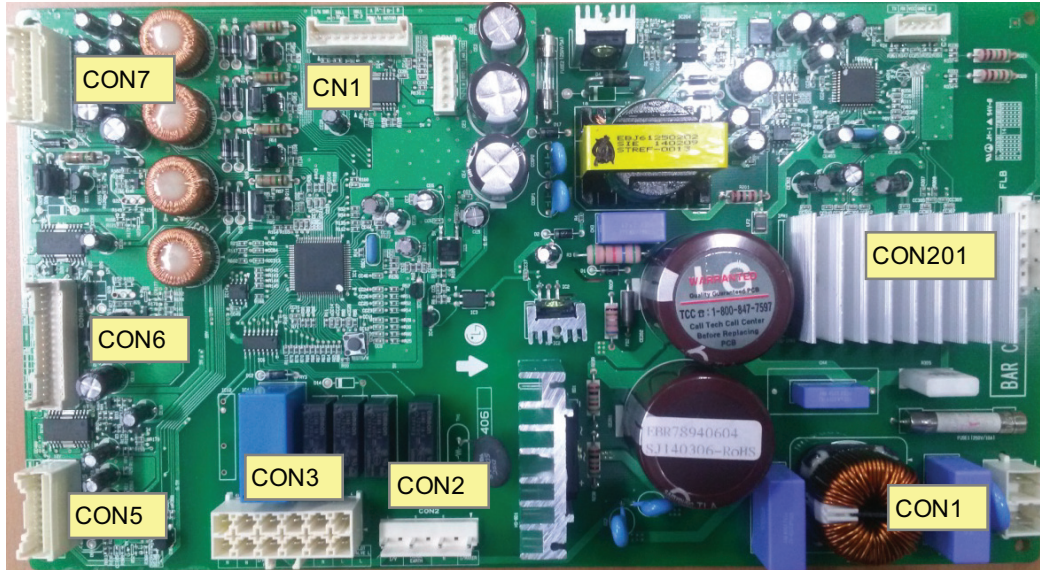

7-2. Display PCB

(P/N : EBR791597)

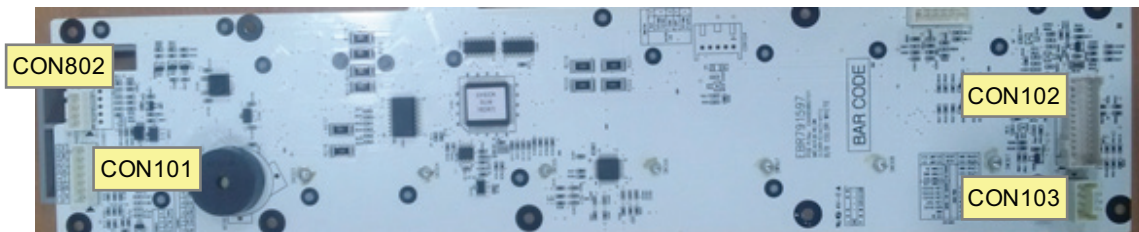

7-3. Sub PCB



8. Trouble Shooting

8-1. Freezer Sensor Error (E FS)

Symptom	Check Point
1. E FS	1. Check for a loose connection 2. Check Sensor Resistance

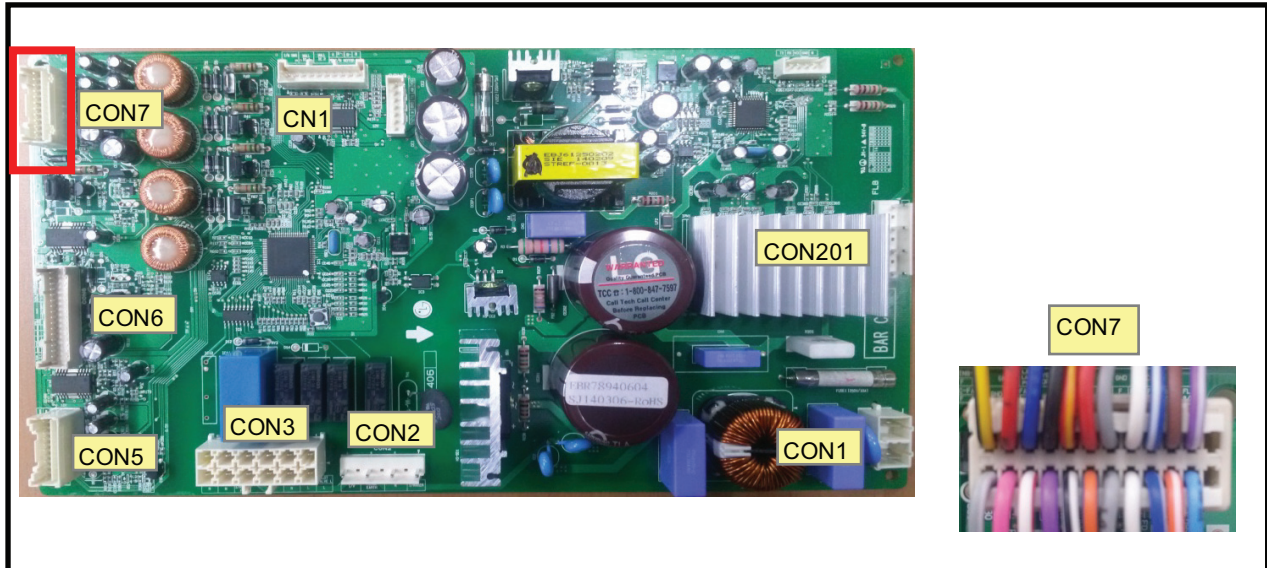

	Resistance [Ω]	
	Short	0
	Open	OFF
Other	Normal	

CON7 17 th pin & 18 th pin	Resistance [Ω]
-22°F / -30°C	40k
-13°F / -25°C	30k
-4°F / -20°C	23k
-13°F / -25°C	17k
14°F / -10°C	13k
23°F / -5°C	10k
32°F / 0°C	8k

Freezer Sensor Error (E FS)

1

Is the Connector disconnected or loose between Main PCB and sensor?

Yes → Reconnect or repair the connector

No →

CON7

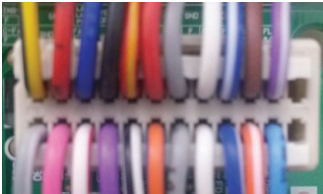

2

Check the Sensor resistance. Is resistance 0Ω (Sensor short)?

Yes → Change the Sensor

No →

3

Check the Sensor resistance. Is resistance OFF (Sensor open)?

Yes → Go to 6

No →

4

Check the Temperature and resistance refer to the table. No problem?

Yes → Change the Sensor

No →

CON7 17 th pin & 18 th pin	Resistance [Ω]
-22°F / -30°C	40k
-13°F / -25°C	30k
-4°F / -20°C	23k
-13°F / -25°C	17k
14°F / -10°C	13k
23°F / -5°C	10k
32°F / 0°C	8k

5

Explain to customer

6

Check the sensor connection. Is the sensor connection normal?

Yes → Replace the refrigerator

No →

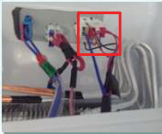

7

Reconnect or repair the connector

8-2. Refrigerator Sensor Error (E rS)

Symptom	Check Point
1. E rS	1. Check for a loose connection 2. Check Sensor Resistance

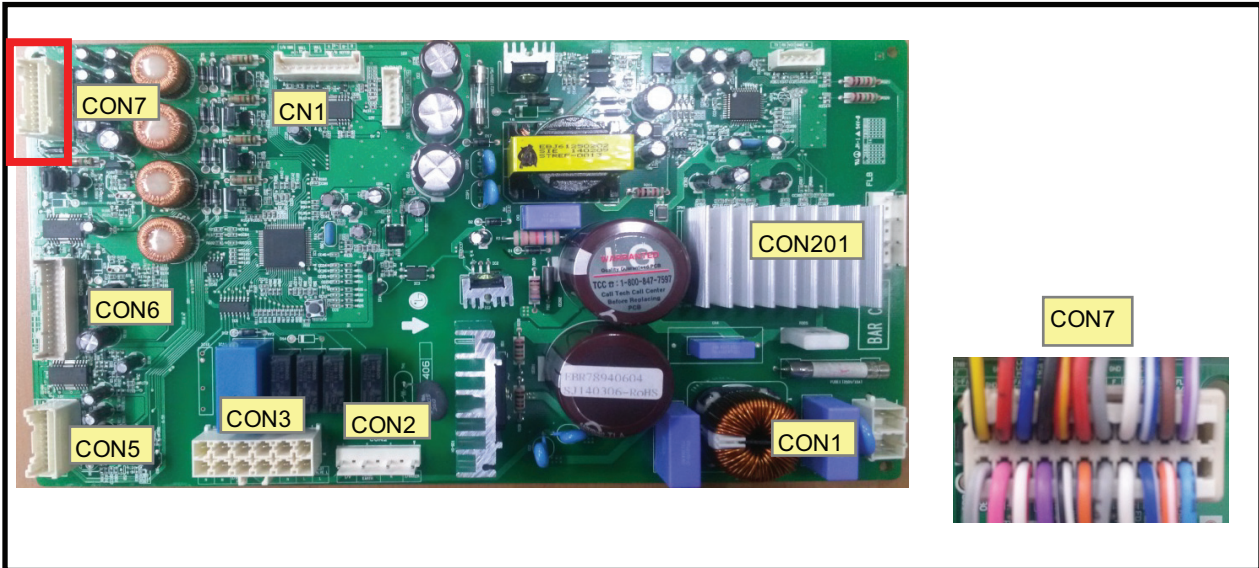

CON7	Resistance [Ω]	Resistance [Ω]	
		Short	0
CON7 15 th pin & 16 th pin	Open	OFF	
	Other	Normal	

CON7 15 th pin & 16 th pin	Resistance [Ω]
23°F / -5°C	38k
32°F / 0°C	30k
41°F / 5°C	24k
50°F / 10°C	19.5k
59°F / 15°C	16k

CON7	Component
3 IRD	ICING FAN MOTOR
5 BL	
1 YL/BK	C-FAN MOTOR
4 PK	
6 W/RD	F-FAN MOTOR
2 G/YWH	
10 W/RBK	RD-SENSOR
12 B/OBL	
8 PR	R-SENSOR
9 RD/YL	
13 GY	F-SENSOR
14 GY	
15 W/H	DRAIN HTR
16 W/H	
17 B/W/H	FD-SENSOR
18 B/W/H	
7 YL	FIU DOOR SW
11 YL	
19 BN	
20 B/W/H	
21 SB	
22 SB	
23	
24	

Refrigerator Sensor Error (E rS)

1

Is the Connector disconnected or loose between Main PCB and sensor?

Yes → Reconnect or repair the connector

No → [Next Step]

CON7

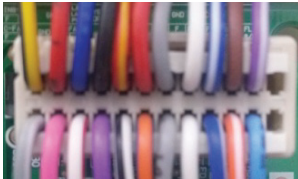

2

Check the Sensor resistance. Is resistance 0Ω (Sensor short)?

Yes → Change the Sensor

No → [Next Step]

3

Check the Sensor resistance. Is resistance OFF (Sensor open)?

Yes → Go to 6

No → [Next Step]

4

Check the Temperature and resistance refer to the table. No problem?

No → Change the Sensor

Yes → [Next Step]

CON7 15 th pin & 16 th pin	Resistance [Ω]
23°F / -5°C	38k
32°F / 0°C	30k
41°F / 5°C	24k
50°F / 10°C	19.5k
59°F / 15°C	16k

5

Explain to customer

6

Check the sensor connection. Is the sensor connection normal?

Yes → Replace the refrigerator

No → [Next Step]



7

Reconnect or repair the connector

8-3. Icing Sensor Error (E IS)

Symptom	Check Point
1. E IS	1. Check for a loose connection 2. Check Sensor Resistance

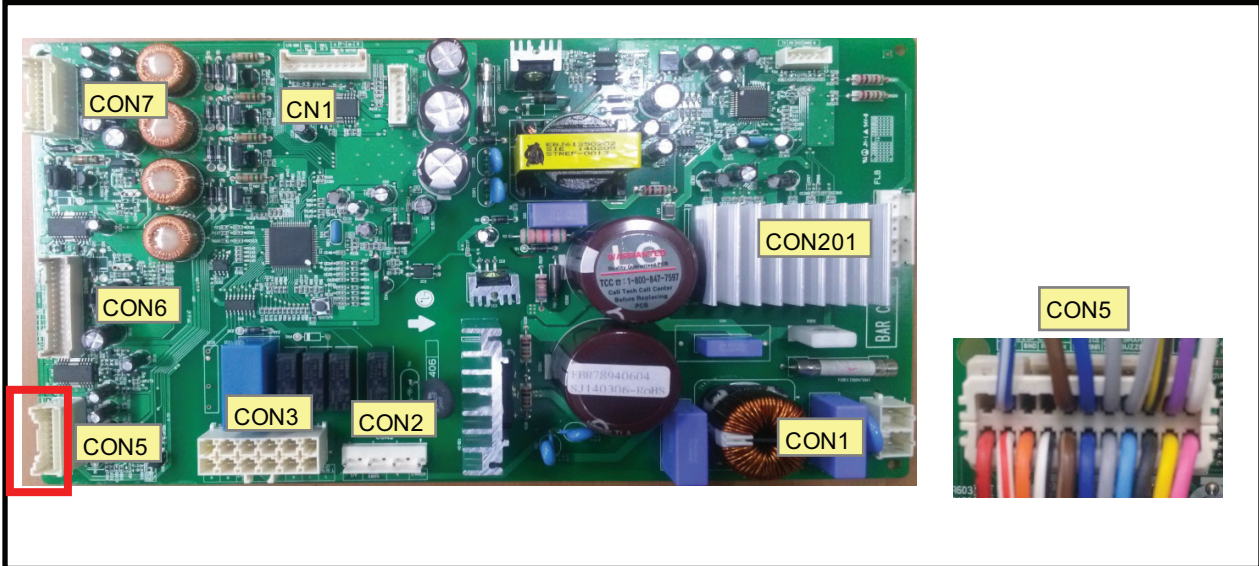

		Resistance [Ω]	
CON5 11 th pin & 12 th pin	Short	0	
	Open	OFF	
	Other	Normal	

CON5 11 th pin & 12 th pin	Resistance [Ω]
-22°F / -30°C	40k
-13°F / -25°C	30k
-4°F / -20°C	23k
-13°F / -25°C	17k
14°F / -10°C	13k
23°F / -5°C	10k
32°F / 0°C	8k

Icing Sensor Error (E IS)

1
Is the Connector disconnected or loose between Main PCB and sensor?

Yes → Reconnect or repair the connector

No → [Next Step]



2
Check the Sensor resistance. Is resistance 0Ω (Sensor short)?

Yes → Change the Sensor

No → [Next Step]

3
Check the Sensor resistance. Is resistance OFF (Sensor open)?

Yes → Go to 6

No → [Next Step]

4
Check the Temperature and resistance refer to the table. No problem?

Yes → Change the Sensor

CON5 11 th pin & 12 th pin	Resistance [Ω]
-22°F / -30°C	40k
-13°F / -25°C	30k
-4°F / -20°C	23k
-13°F / -25°C	17k
14°F / -10°C	13k
23°F / -5°C	10k
32°F / 0°C	8k

No problem? → [Next Step]

5
Explain to customer

6
Check the sensor connection. Is the sensor connection normal?

Yes → Replace the refrigerator

No → [Next Step]



7
Reconnect or repair the connector

8-4. Defrost Sensor Error (F dS)

Symptom	Check Point
1. F dS	1. Check for a loose connection 2. Check Sensor Resistance

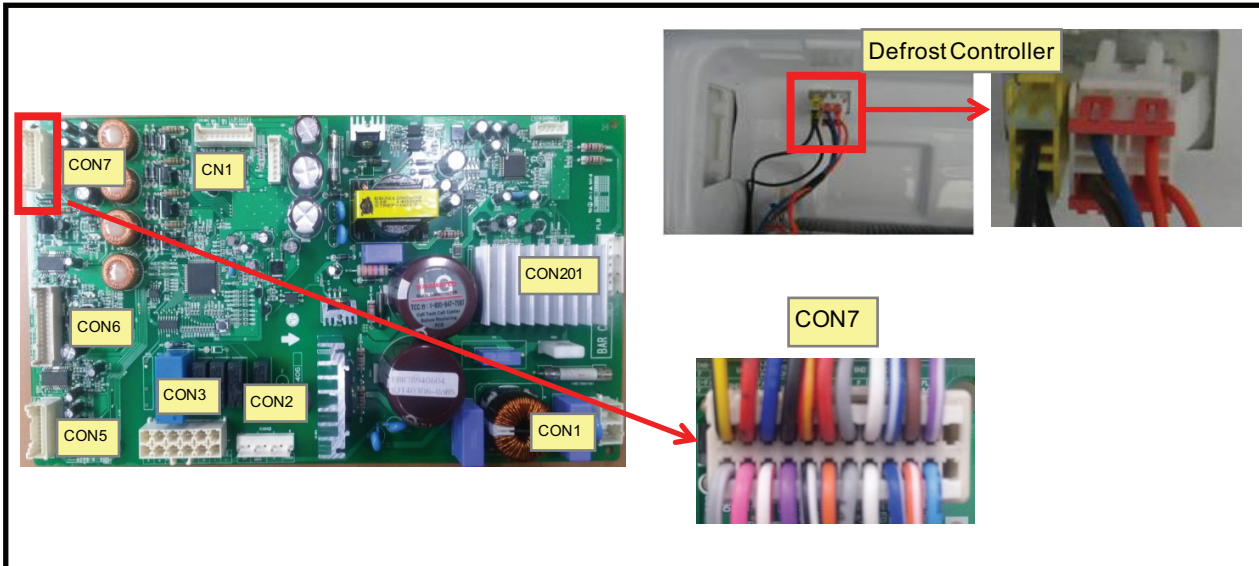

		Resistance [Ω]	
CON7 19 th pin & 20 th pin	Short	0	
	Open	OFF	
	Other	Normal	

CON7 19 th pin & 20 th pin	Resistance [Ω]
23°F / -5°C	38k
32°F / 0°C	30k
41°F / 5°C	24k
50°F / 10°C	19.5k
59°F / 15°C	16k

The wiring diagram for the CON7 connector shows 24 pins. The connections are as follows:

- Pin 3: IRD (ICING FAN MOTOR)
- Pin 5: BL (ICING FAN MOTOR)
- Pin 1: YL/BK (ICING FAN MOTOR)
- Pin 4: PK (C-FAN MOTOR)
- Pin 6: WH/RD (C-FAN MOTOR)
- Pin 2: GY/WH (C-FAN MOTOR)
- Pin 10: WH/BK (F-FAN MOTOR)
- Pin 12: BO/BL (F-FAN MOTOR)
- Pin 8: PR (F-FAN MOTOR)
- Pin 9: RD/YL (DRAIN HTR)
- Pin 13: GY (RD-SENSOR)
- Pin 14: GY (R-SENSOR)
- Pin 15: WH (R-SENSOR)
- Pin 16: WH (F-SENSOR)
- Pin 17: BL/WH (F-SENSOR)
- Pin 18: BL/WH (F-SENSOR)
- Pin 7: YL (DRAIN HTR)
- Pin 11: YL (DRAIN HTR)
- Pin 19: BN (FD-SENSOR)
- Pin 20: RW/WH (FD-SENSOR)
- Pin 21: SB (F/U DOOR SW)
- Pin 22: SB (F/U DOOR SW)
- Pin 23: (Empty)
- Pin 24: (Empty)

Defrost Sensor Error (F dS)

1
Is the Connector disconnected or loose between Main PCB, Defrost controller and Sensor?

Yes → Reconnect or repair the connector

No → 2

CON7

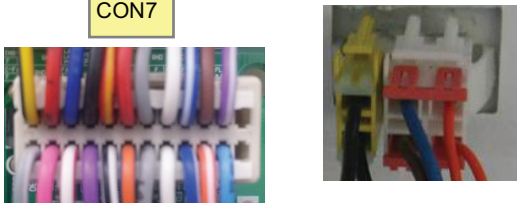

2
Check the Sensor resistance. Is resistance 0Ω (Sensor short)?

Yes → Change the Sensor

No → 3

3
Check the Sensor resistance. Is resistance OFF (Sensor open)?

Yes → Replace the refrigerator

No → 4

4
Check the Sensor resistance. Is resistance normal?

Yes → 5

5
Check the Temperature and resistance refer to the table. No problem?

CON7 19 th pin & 20 th pin	Resistance [Ω]
23°F / -5°C	38k
32°F / 0°C	30k
41°F / 5°C	24k
50°F / 10°C	19.5k
59°F / 15°C	16k

Yes → 6

6
Explain to customer

8-5. Defrost Sensor Error (r dS)

Symptom	Check Point
1. r dS	1. Check for a loose connection 2. Check Sensor Resistance

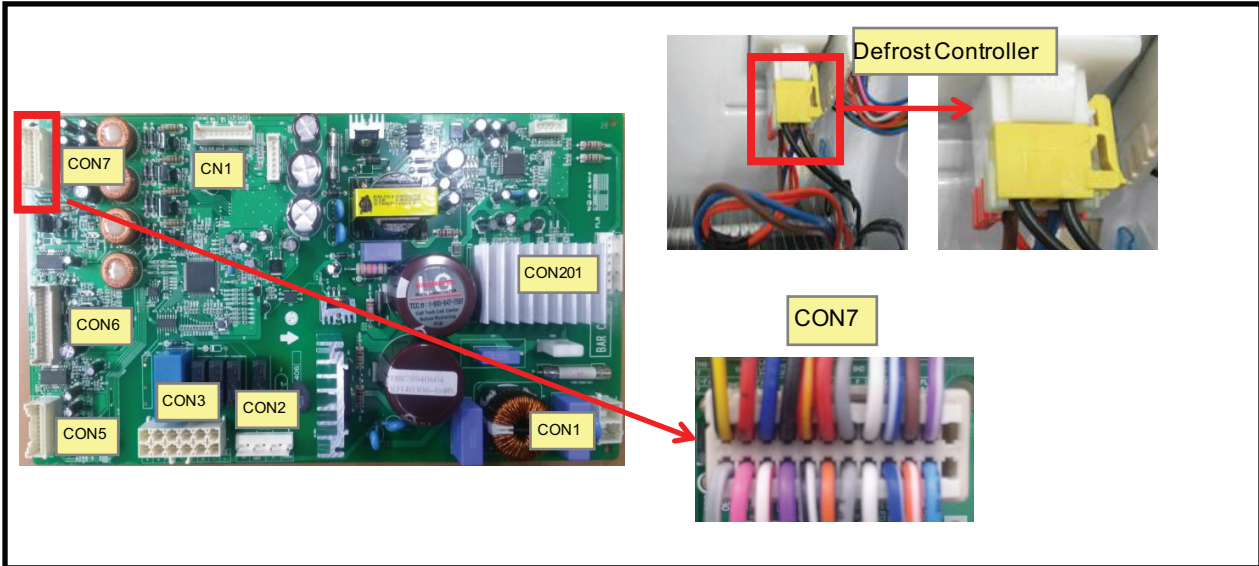

CON7		Resistance [Ω]	
CON7 13 th pin & 14 th pin	Short	0	
	Open	OFF	
	Other	Normal	

CON7 13 th pin & 14 th pin	Resistance [Ω]
23°F / -5°C	38k
32°F / 0°C	30k
41°F / 5°C	24k
50°F / 10°C	19.5k
59°F / 15°C	16k

CON7	Component
3	RD
5	BL
1	YL/BK
4	PK
6	WH/RD
2	GY/WH
10	WH/BK
12	BO/BL
8	PR
9	RD/YL
13	GY
14	GY
15	WH
16	WH
17	BL/WH
18	BL/WH
7	YL
11	YL
19	BN
20	BO/WH
21	SB
22	SB
23	
24	

ICING FAN MOTOR
G-FAN MOTOR
F-FAN MOTOR
RD-SENSOR
R-SENSOR
F-SENSOR
DRAIN HTR
FD-SENSOR
FIU DOOR SW

Defrost Sensor Error (r dS)

1
Is the Connector disconnected or loose between Main PCB, Defrost controller and Sensor?

Yes → Reconnect or repair the connector

No → 2

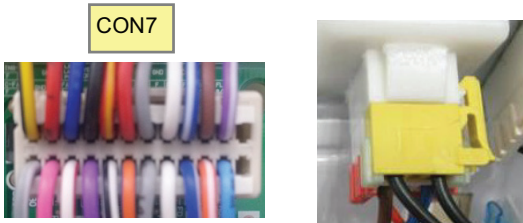

CON7

2
Check the Sensor resistance. Is resistance 0Ω (Sensor short)?

Yes → Change the Sensor

No → 3

3
Check the Sensor resistance. Is resistance OFF (Sensor open)?

Yes → Replace the refrigerator

No → 4

4
Check the Sensor resistance. Is resistance normal?

Yes → 5

5
Check the Temperature and resistance refer to the table. No problem?

CON7 13 th pin & 14 th pin	Resistance [Ω]
23°F / -5°C	38k
32°F / 0°C	30k
41°F / 5°C	24k
50°F / 10°C	19.5k
59°F / 15°C	16k

Yes → 6

6
Explain to customer

8-6. Defrost Heater Error (F dH)

Symptom	Check Point
1. F dH	<ol style="list-style-type: none"> 1. Check the door gasket 2. Check the Defrost Heater 3. Check the PCB output voltage

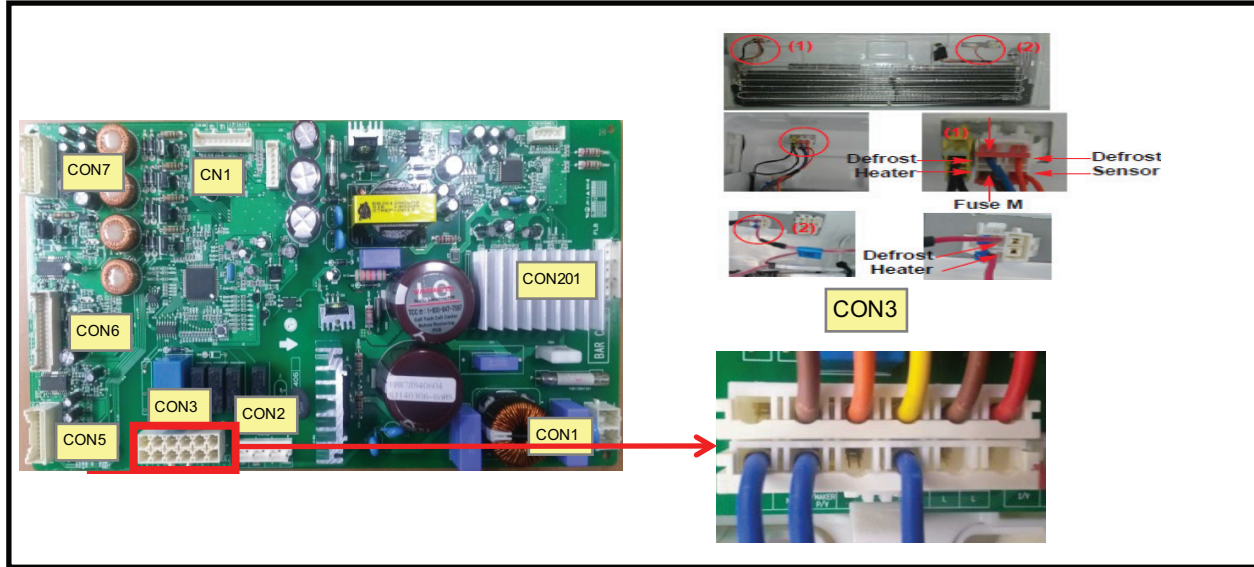

Part	Resistance [Ω]
FUSE-M	0
Defrost Heater	(1) 62~70 (2) 144~167
Defrost Sensor	22k \uparrow

TEST MODE 3	Voltage [V]
CON3 6 th pin & 10 th pin	112V ~ 116V

TEST MODE 1	Voltage [V]
CON3 6 th pin & 10 th pin	0V

Defrost Heater Error (F dH)

1
Check the Door gasket .
Is door gasket damaged?

Yes
Replace the Door gasket

No

2
Check the Defrost control part.
Is heater resistance 42~50Ω ?

No
Change Fuse-M

TEST MODE 1	RESISTANCE [Ω]
CON3 6 th pin 10 th pin	42~50Ω

Yes

3
Check the Defrost control part.
Is Defrost Sensor resistance 22kΩ↑ or OFF?

OFF
Replace product

CON7 13 th pin & 14 th pin	Resistance [Ω]
23°F / -5°C	38k
32°F / 0°C	30k
41°F / 5°C	24k
50°F / 10°C	19.5k
59°F / 15°C	16k

22kΩ↑

**4 Input Test 3 Mode
(Push the button 3 times)**
Check the Heater Voltage.
Is voltage 112~116V?

No
1. Check the input Voltage
2. Replace Main PCB

TEST MODE 3	Voltage [V]
CON3 6 th pin ~ 10 th pin	112V ~ 116V

Yes

**5 Input Test 1 Mode
(Push the button 1 times)**
Check the Heater Voltage.
Is voltage 0V?

No
Replace Main PCB

TEST MODE 1	Voltage [V]
CON3 6 th pin 10 th pin	0V

Yes

8-7. Defrost Heater Error (r dH)

Symptom	Check Point
1. r dH	<ol style="list-style-type: none"> 1. Check the door gasket 2. Check the Defrost Heater 3. Check the PCB output voltage

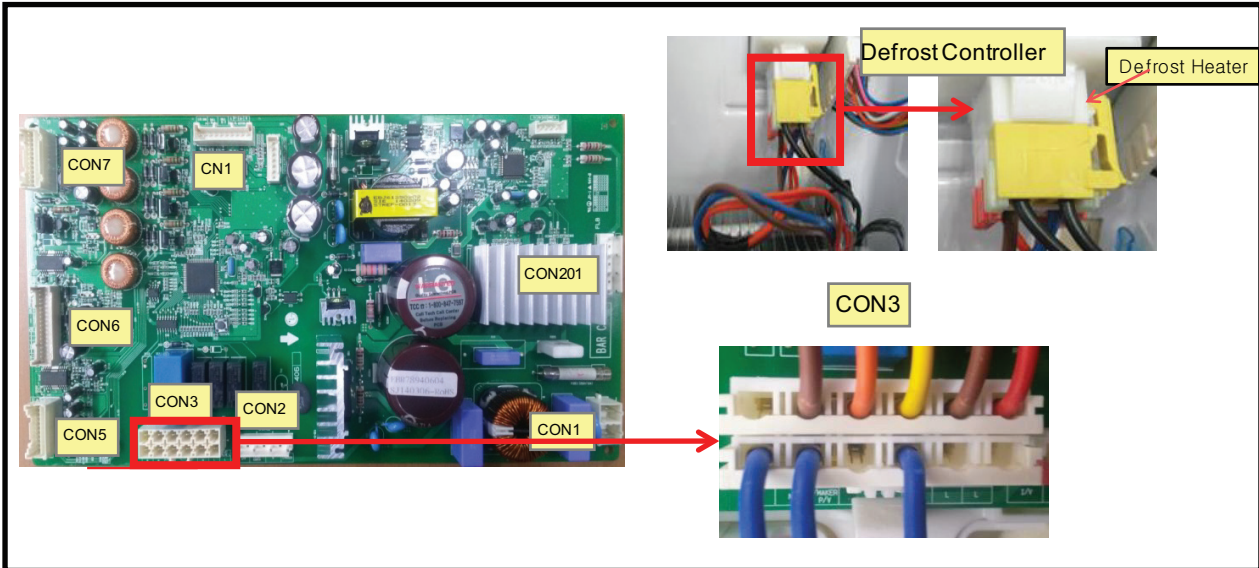

Part	Resistance [Ω]
FUSE-M	0
Defrost Heater	103~119
Defrost Sensor	22k \uparrow

TEST MODE 3	Voltage [V]
CON3 6 th pin & 9 th pin	112V ~ 116V

TEST MODE 1	Voltage [V]
CON3 6 th pin & 9 th pin	0V

Part	Resistance [Ω]
FUSE-M	0
Defrost Heater	103~119
Defrost Sensor	22k \uparrow

TEST MODE 3	Voltage [V]
CON3 6 th pin & 9 th pin	112V ~ 116V

TEST MODE 1	Voltage [V]
CON3 6 th pin & 9 th pin	0V

Defrost Heater Error (r dH)

1
Check the Door gasket .
Is door gasket damaged?

Yes
Replace the Door gasket

No

2
Check the Defrost control part.
Is heater resistance 105~117Ω ?

No
Change Fuse-M

TEST MODE 3	RESISTANCE [Ω]
CON3 6 th pin & 9 th pin	105~117Ω

Yes

3
Check the Defrost control part.
Is Defrost Sensor resistance 22kΩ↑ or OFF?

OFF
Change Defrost Sensor

CON7 13 th pin & 14 th pin	Resistance [Ω]
23°F / -5°C	38k
32°F / 0°C	30k
41°F / 5°C	24k
50°F / 10°C	19.5k
59°F / 15°C	16k

22kΩ↑

**4 Input Test 3 Mode
(Push the button 3 times)**
Check the Heater Voltage.
Is voltage 112~116V?

No
1. Check the input Voltage
2. Replace Main PCB

TEST MODE 3	Voltage [V]
CON3 6 th pin & 9 th pin	112V ~ 116V

Yes

**5 Input Test 1 Mode
(Push the button 1 times)**
Check the Heater Voltage.
Is voltage 0V?

No
Replace Main PCB

TEST MODE 1	Voltage [V]
CON3 6 th pin & 9 th pin	0V

Yes

8-8. Refrigerator Fan Error (E rF)

Symptom	Check Point
1. E rF	1. Check the air flow 2. Check the PCB Fan motor voltage

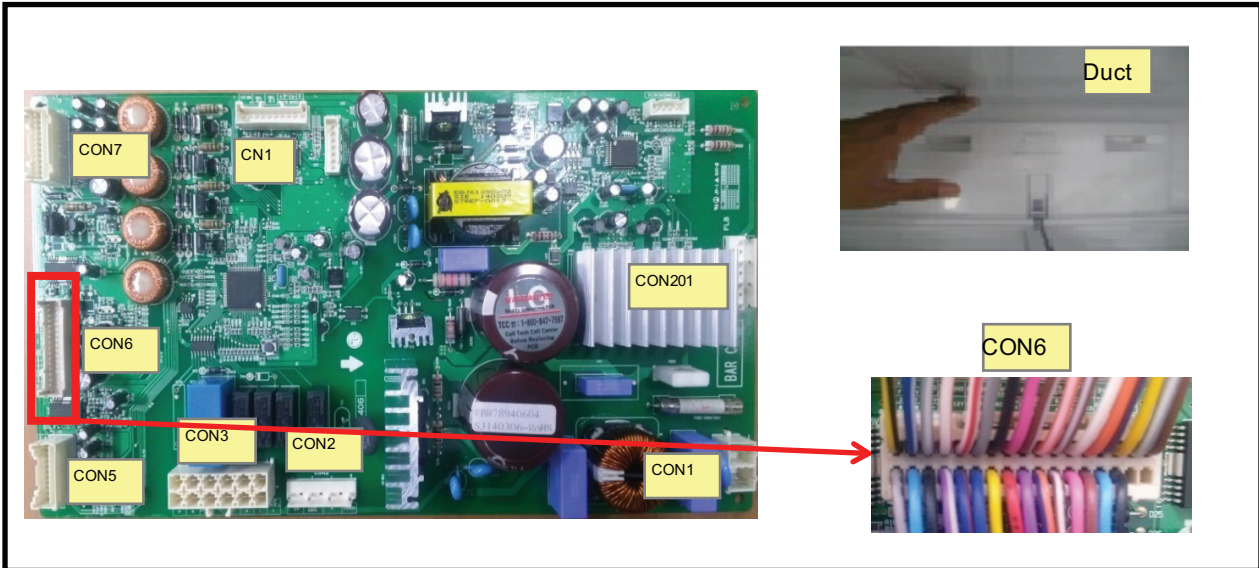

TEST MODE 1	Voltage [V]
CON6 3 rd pin & 5 th pin	8~12V
CON6 1 st pin & 5 th pin	Not 0V, 5V

Refrigerator Fan Error (E rF)

1 Reset the unit and Input Test1 Mode. (Push the button 1 time)

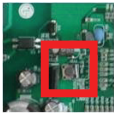

2 Open the freezer door and Check the air flow. Windy?



Yes
Go to 4

3 Check the Fan motor. Rotate fan using hand. It feel sticky?



Yes
Change the Fan motor

4 Check the Fan Motor voltage Is Fan Motor voltage 8~12V?

No
Replace Main PCB

TEST MODE 1	Voltage [V]
CON6 3 rd pin ~ 5 th pin	8~12V

5 Check the Fan Motor voltage Is Fan Feed Back voltage 0V, 5V?

Yes
Change the motor

TEST MODE 1	Voltage [V]
CON6 1 st pin ~ 5 th pin	Not 0V, 5V

6 Explain to customer

8-9. Freezer Fan Error (E FF)

Symptom	Check Point
1. E FF	<ol style="list-style-type: none"> 1. Check the air flow 2. Check the Fan Motor 3. Check the PCB Fan motor voltage

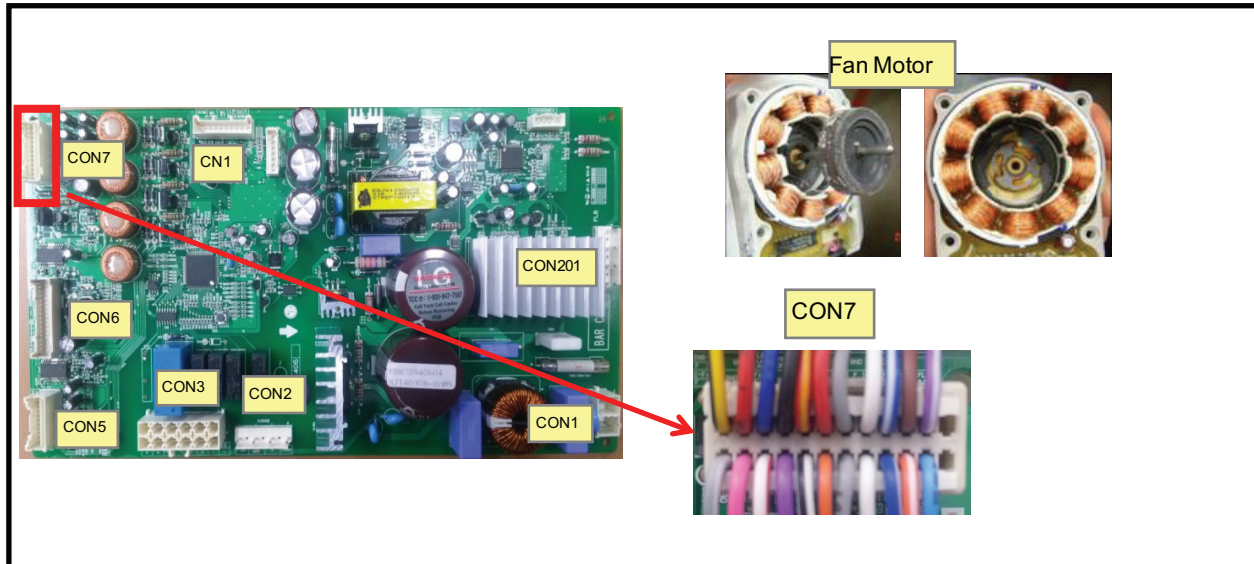

TEST MODE 1	Voltage [V]
CON7 10 th pin & 12 th pin	8~12V
CON7 8 th pin & 12 th pin	Not 0V, 5V

CON7	Pin	Color	Component
3	RD		ICING FAN MOTOR
5	BL		
1	YL BK		
4	PK		C-FAN MOTOR
6	WH RD		
2	GY WH		
10	WH BK		F-FAN MOTOR
12	BO BL		
8	PR		
9	RD VL		⊖
13	GY		RD-SENSOR
14	GY		R-SENSOR
15	WH		R-SENSOR
16	WH		F-SENSOR
17	BL WH		F-SENSOR
18	BL WH		F-SENSOR
7	YL		DRAIN HTR
11	YL		DRAIN HTR
19	BN		FD-SENSOR
20	BO WH		FD-SENSOR
21	SB		F/U DOOR SW
22	SB		F/U DOOR SW
23			
24			

Freezer Fan Error (E FF)

1 Reset the unit and Input Test1 Mode. (Push the button 1 time)



2 Open the freezer door and Check the air flow. Windy?



Yes
Go to 4

3 Check the Fan motor. Rotate fan using hand. It feel sticky?

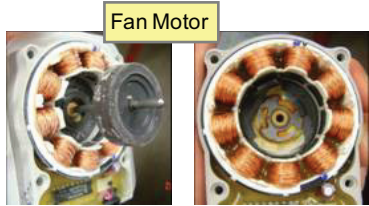

Yes
Change the Fan motor

4 Check the Fan Motor voltage Is Fan Motor voltage 8~12V?

No
Replace Main PCB

TEST MODE 1	Voltage [V]
CON7 10 th pin ~ 12 th pin	8~12V

5 Check the Fan Motor voltage Is Fan Feed Back voltage 0V, 5V?

Yes
Change the motor

TEST MODE 1	Voltage [V]
CON7 8 th pin ~ 12 th pin	Not 0V, 5V

6 Explain to customer

8-10. Icing Fan Error (E IF)

Symptom	Check Point
1. E IF	<ol style="list-style-type: none"> 1. Check the air flow 2. Check the Connector 3. Check the PCB Fan motor voltage

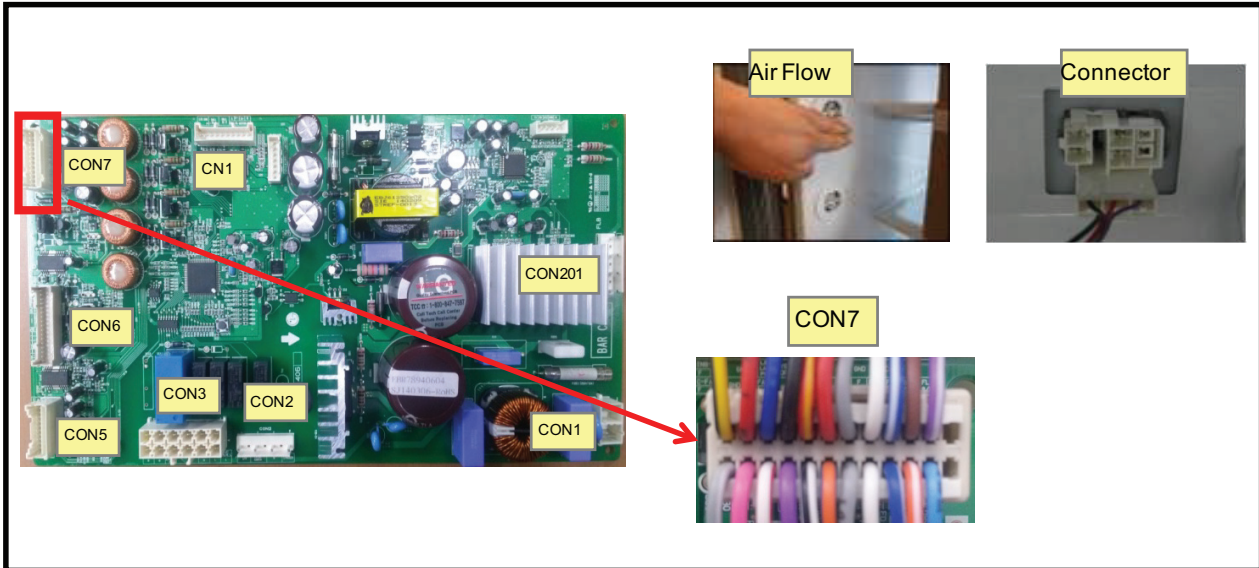

TEST MODE 1	Voltage [V]
CON7 3 rd pin & 5 th pin	8~12V
CON7 1 st pin & 5 th pin	Not 0V, 5V

CON7	Component
3 RD	ICING FAN MOTOR
5 BL	
1 W/RK	
4 PK	C-FAN MOTOR
6 MHRD	
2 GYWH	F-FAN MOTOR
10 MHEK	
12 BOBL	RD-SENSOR
8 PR	
9 RDYL	R-SENSOR
13 GY	
14 GY	F-SENSOR
15 WH	
16 WH	DRAIN HTR
17 BLWH	
18 BLWH	FD-SENSOR
7 YL	
11 YL	FIU DOOR SW
19 BN	
20 BOWH	
21 SB	
22 SB	
23	
24	

Freezer Fan Error (E IF)

1 Reset the unit and Input Test1 Mode.
(Push the button 1 time)

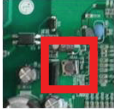

2 Open the freezer door and Check the air flow. Windy?
Yes → Go to 4
No → 3



3 Check the Fan motor. Rotate fan using hand. It feel sticky?
Yes → Change the Fan motor
No → 4

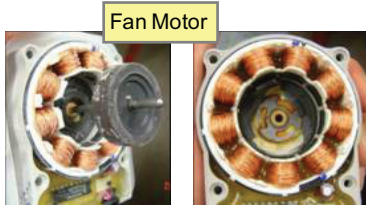

4 Check the Fan Motor voltage
Is Fan Motor voltage 8~12V?
No → Replace Main PCB
Yes → 5

TEST MODE 1	Voltage [V]
CON7 3 rd pin ~ 5 th pin	8~12V

5 Check the Fan Motor voltage
Is Fan Feed Back voltage 0V, 5V?
Yes → Change the motor
No → 6

TEST MODE 1	Voltage [V]
CON7 1 st pin ~ 5 th pin	Not 0V, 5V

6 Explain to customer

8-11. Condenser Fan Error (E CF)

Symptom	Check Point
1. E CF	<ol style="list-style-type: none"> 1. Check the air flow 2. Check the Connector 3. Check the PCB Fan motor voltage

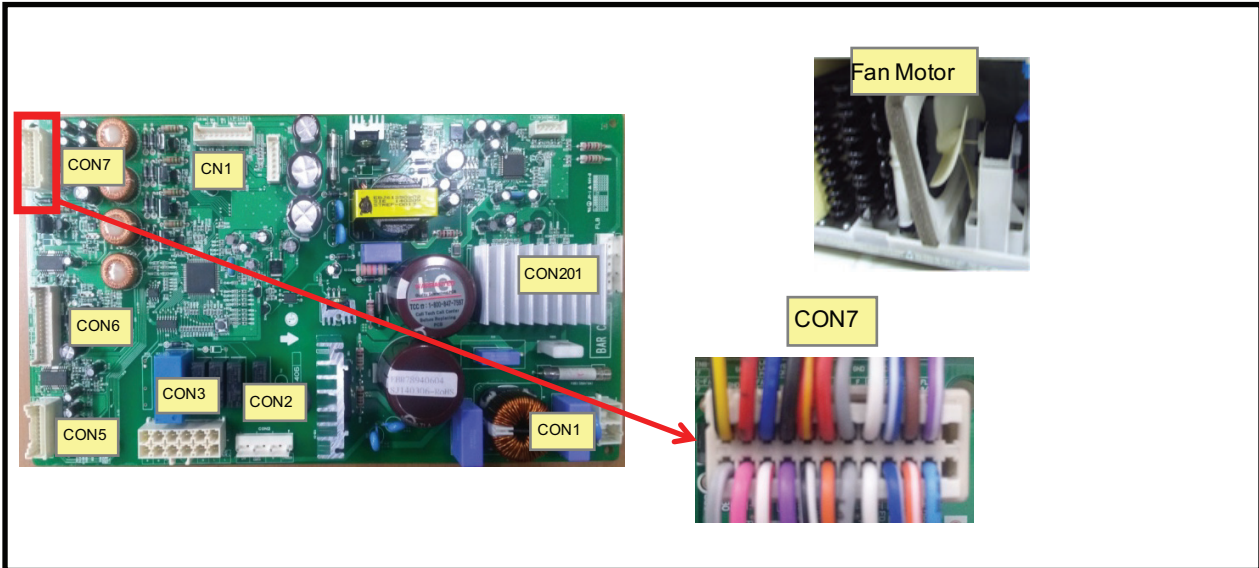

TEST MODE 1	Voltage [V]
CON7 4 th pin & 6 th pin	8~12V
CON7 2 nd pin & 6 th pin	Not 0V, 5V

Condenser Fan Error (E CF)

1 Reset the unit and Input Test1 Mode. (Push the button 1 time)

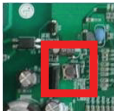

2 Check the fan rotating. Does fan rotate?



Yes → Go to 4

3 Check the Fan motor. Rotate fan using hand. It feel sticky?



Yes → Change the Fan motor

4 Check the Fan Motor voltage Is Fan Motor voltage 8~12V?

No → Replace Main PCB

TEST MODE 1	Voltage [V]
CON7 4 th pin ~6 th pin	8~12V

Yes →

5 Check the Fan Motor voltage Is Fan Feed Back voltage 0V, 5V?

Yes → Change the motor

TEST MODE 1	Voltage [V]
CON7 2 th pin ~6 th pin	Not 0V, 5V

No →

6 Explain to customer

8-12. Communication Error (E CO)

Symptom	Check Point
1. E CO	<ol style="list-style-type: none"> 1. Check the loose connection 2. Check the Hinge connection

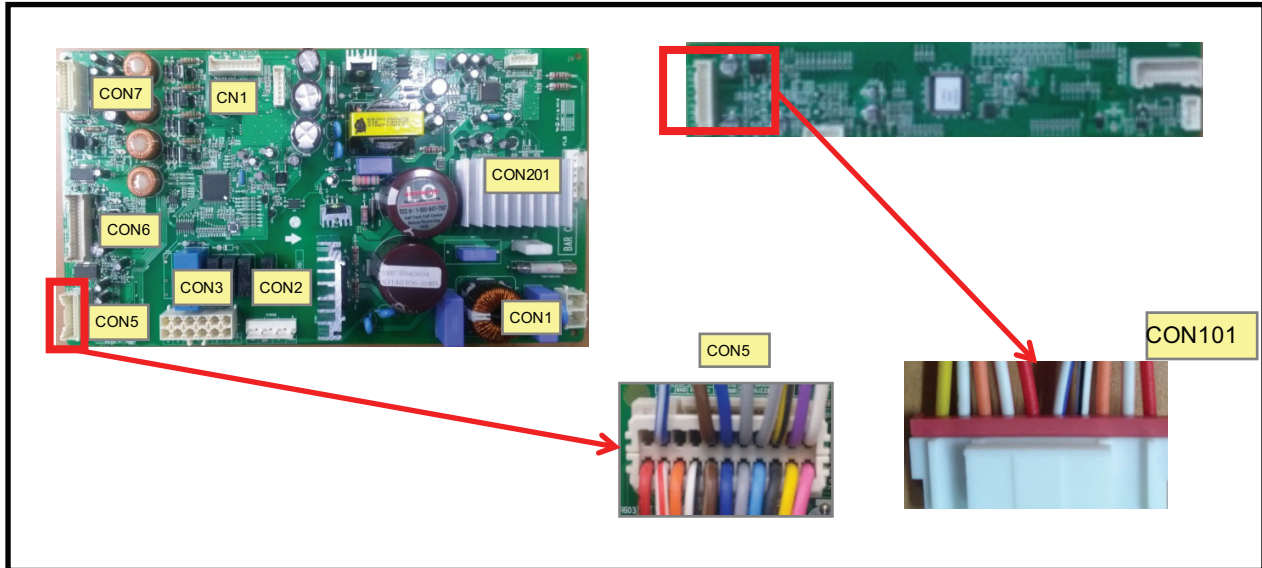

	Voltage [V]
CON101 1 st pin & 2 nd pin	12V
CON101 2 nd pin & 3 rd pin	Not 0V, 5V
CON101 2 nd pin & 4 th pin	Not 0V, 5V
CON5 4 th pin & 6 th pin	Not 0V, 5V
CON5 4 th pin & 8 th pin	Not 0V, 5V

Communication Error (E CO)

1
Check the loose connection

2
Check the voltage.
Is CON101 1st pin ~ 2nd pin voltage 12V?

No → Check the Hinge (loose connection)
Change the Main PCB



	Voltage [V]
CON101 1 st pin ~ 2 nd pin	12V

Yes →

3
Check the voltage.
Is CON101 2nd pin ~ 3rd pin voltage 0V or 5V?

Yes → Change the Display PCB



	Voltage [V]
CON101 2 nd pin ~ 3 rd pin	Not 0V, 5V

No →

4
Check the voltage.
Is CON101 2nd pin ~ 4th pin voltage 0V or 5V?

Yes → Change the Main PCB



	Voltage [V]
CON101 2 nd pin ~ 4 th pin	Not 0V, 5V

No →

5
Check the voltage.
Is CON5 4th pin ~ 6th pin voltage 0V or 5V?

Yes → Change the Display PCB

	Voltage [V]
CON5 4 th pin ~ 6 th pin	Not 0V, 5V

No →

6
Check the voltage.
Is CON5 4th pin ~ 8th pin voltage 0V or 5V?

Yes → Change the Main PCB

	Voltage [V]
CON5 4 th pin ~ 8 th pin	Not 0V, 5V

No →

7
Explain to customer

8-13. Cube mode doesn't work

Symptom	Check Point
1. Cube mode doesn't work	1. Check the loose connection 2. Check the resistance

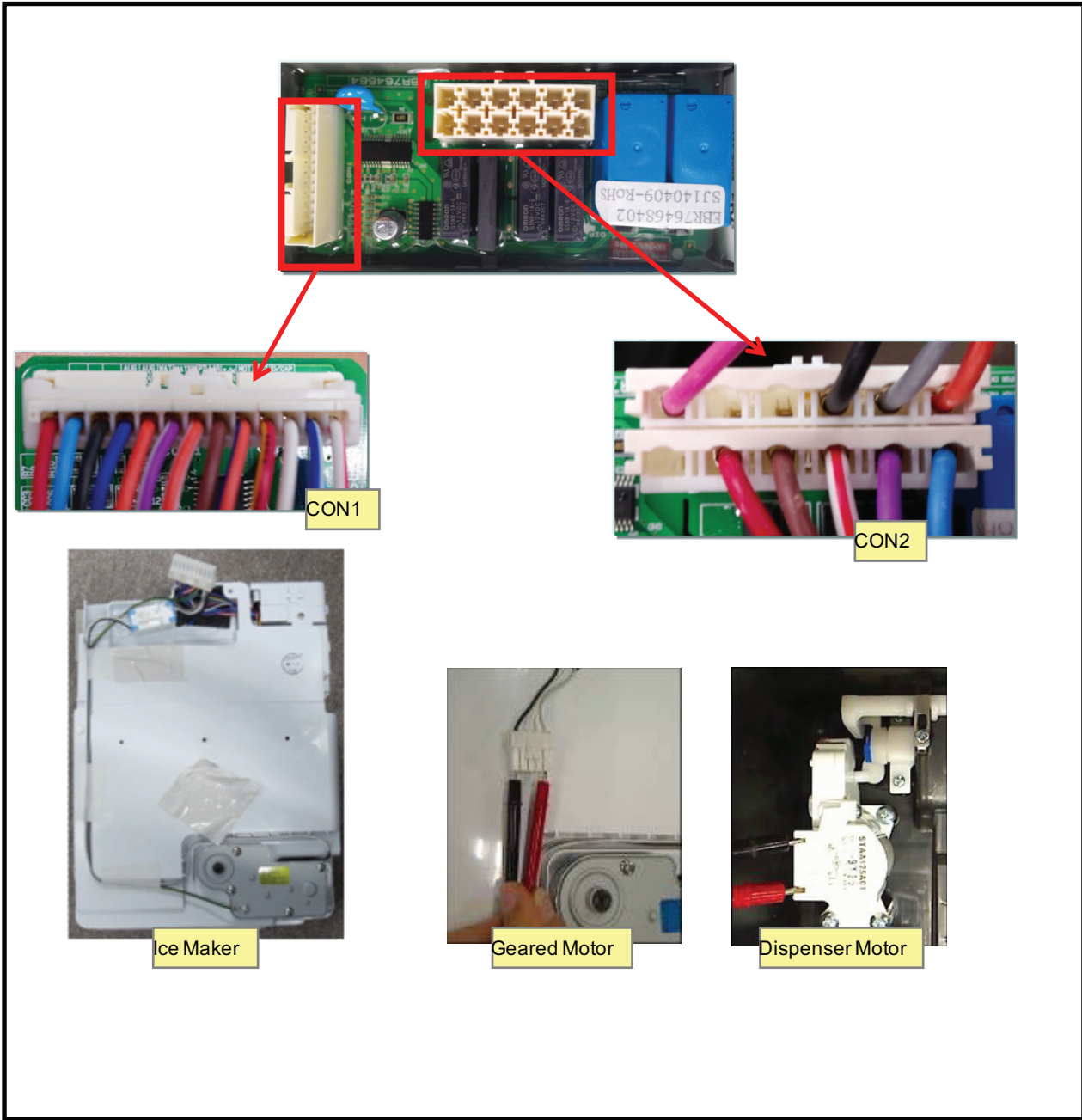

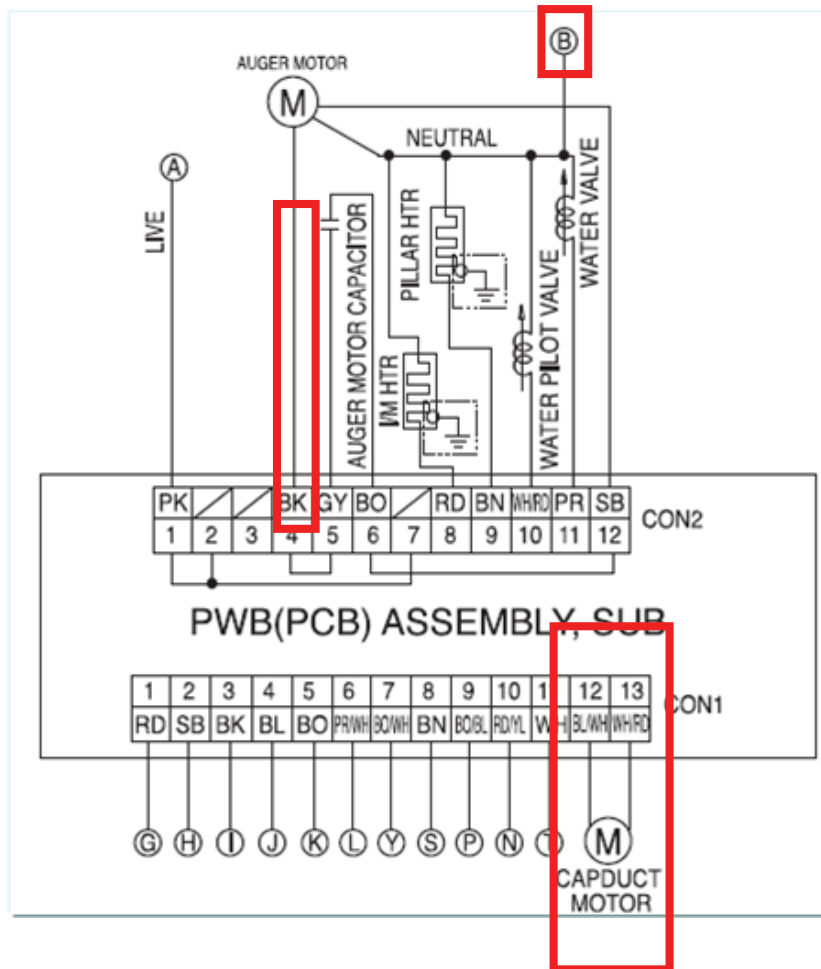

LEVER S/W	Voltage [V]	
CON2 4 th pin ~ B(NEUTRAL)	Pushing	112~115V
	Not Pushing	0~2V
CON1 12 th pin ~ 13 th pin	Pushing	9~12V
	Not Pushing	0~2V

	Resistance [Ω]
Geared Motor	31.1 ~ 42.1
Dispenser Motor	9.9 ~ 12.1

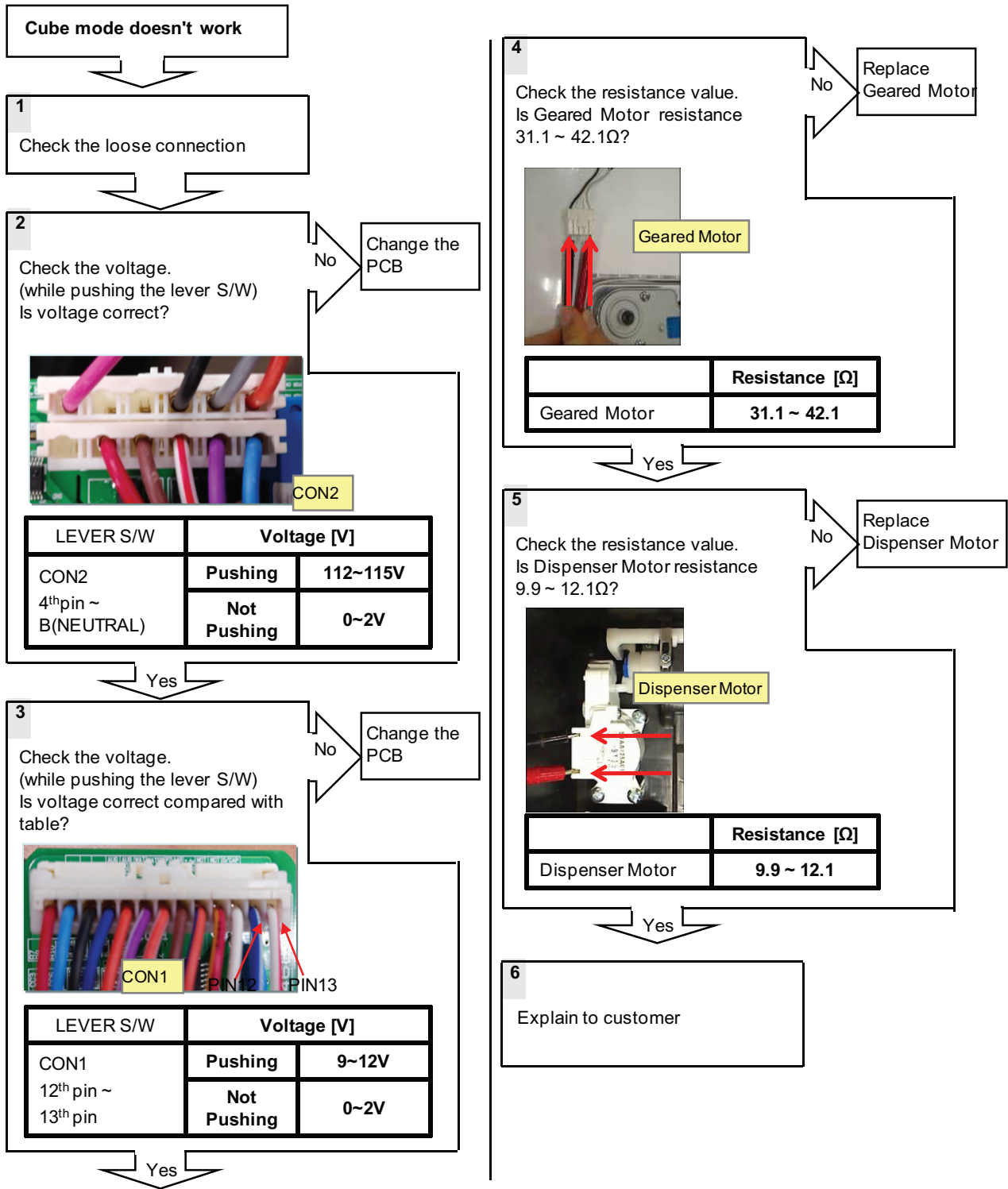

8-14. Crush mode doesn't work

Symptom	Check Point
1. Crush mode doesn't work	1. Check the loose connection 2. Check the resistance

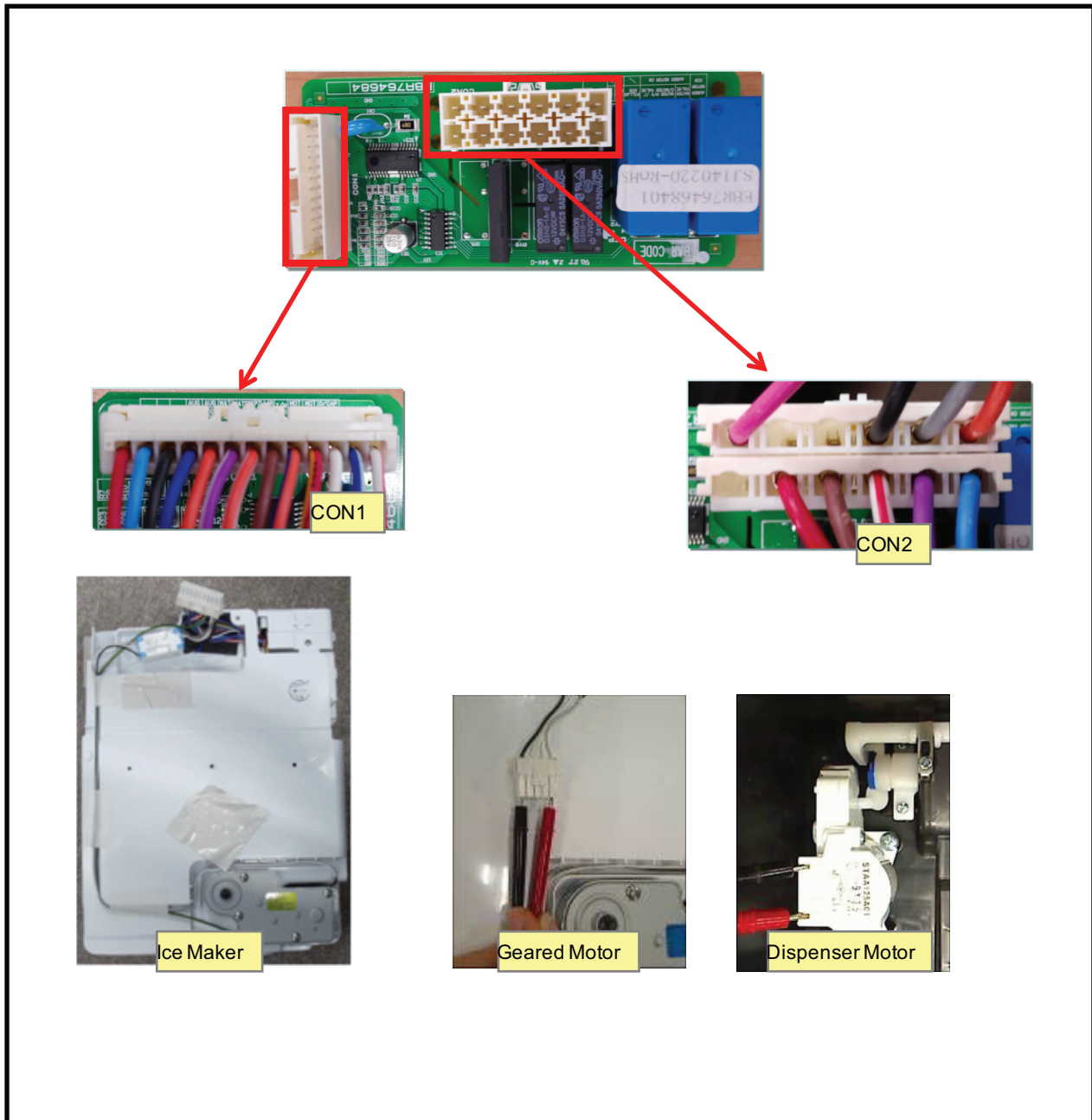

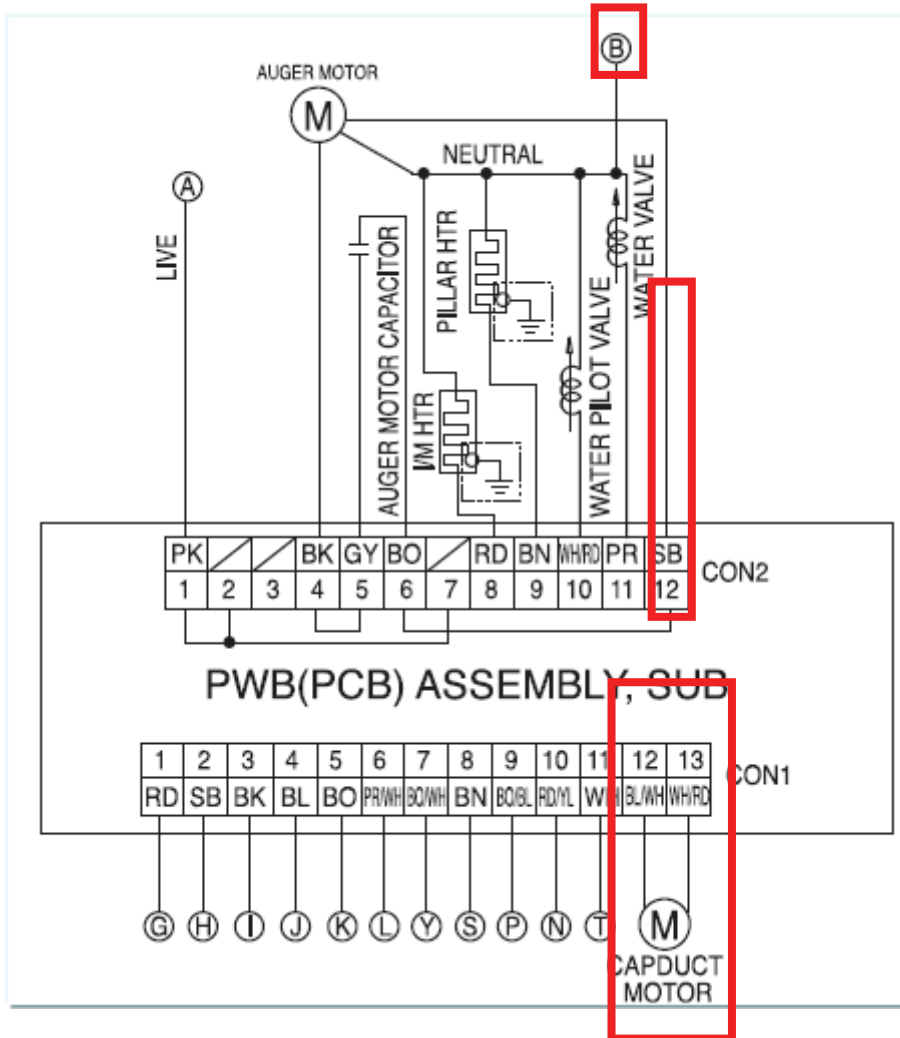

LEVER S/W	Voltage [V]	
CON2 12 th pin ~ B(NEUTRAL)	Pushing	112~115V
	Not Pushing	0~2V
CON1 12 th pin ~ 13 th pin	Pushing	9~12V
	Not Pushing	0~2V

	Resistance [Ω]
Geared Motor	31.1 ~ 42.1
Dispenser Motor	9.9 ~ 12.1

Crush mode doesn't work

1
Check the loose connection

2
Check the voltage.
(while pushing the lever S/W)
Is voltage correct?

No
Change the PCB

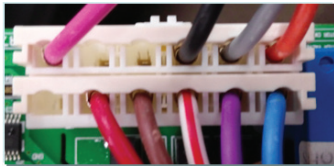

LEVER S/W	Voltage [V]	
CON2 12 th pin ~ B(NEUTRAL)	Pushing	112~115V
	Not Pushing	0~2V

Yes

3
Check the voltage.
(while pushing the lever S/W)
Is voltage correct compared with table?

No
Change the PCB

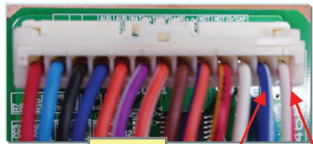

LEVER S/W	Voltage [V]	
CON1 12 th pin ~ 13 th pin	Pushing	9~12V
	Not Pushing	0~2V

Yes

4
Check the resistance value.
Is Geared Motor resistance
31.1 ~ 42.1Ω?

No
Replace Geared Motor

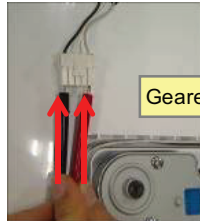

	Resistance [Ω]
Geared Motor	31.1 ~ 42.1

Yes

5
Check the resistance value.
Is Dispenser Motor resistance
9.9 ~ 12.1Ω?

No
Replace Dispenser Motor

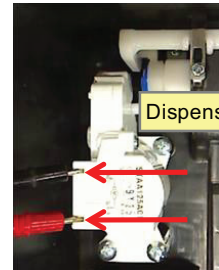

	Resistance [Ω]
Dispenser Motor	9.9 ~ 12.1

Yes

6
Explain to customer

8-15. Water mode doesn't work

Symptom	Check Point
1. Water mode doesn't work	1. Check the loose connection 2. Check the resistance valve

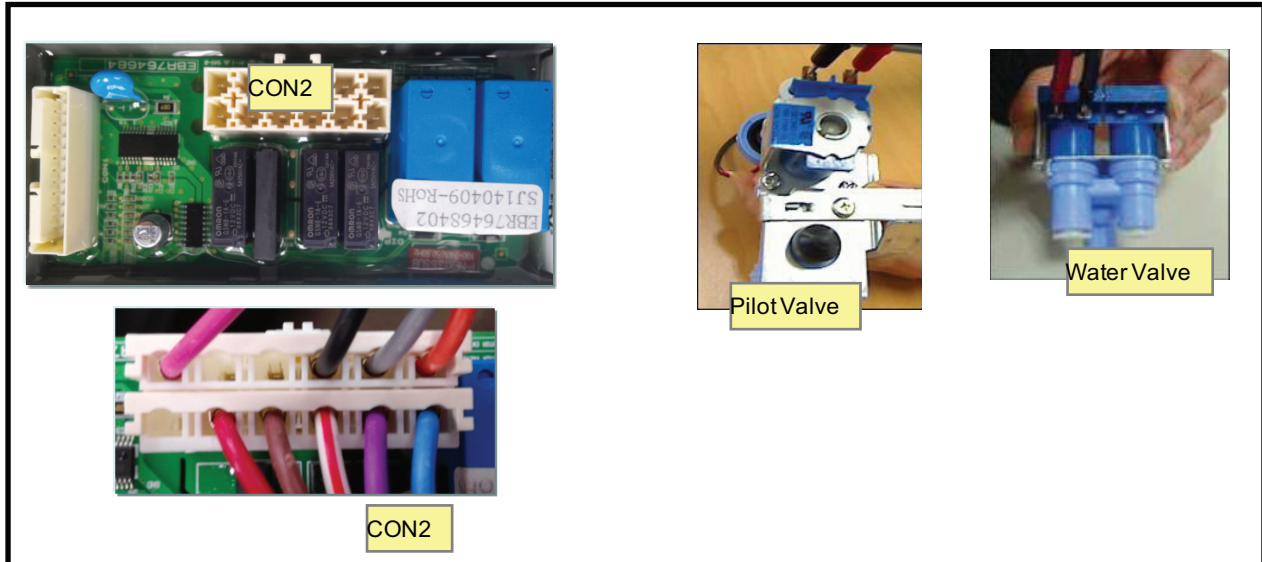

PWB(PCB) ASSEMBLY, SUB

LEVER S/W	Voltage [V]	
CON2 11 th pin ~ B(NEUTRAL)	Pushing	112~115V
	Not Pushing	0~2V
CON2 10 th pin ~ B(NEUTRAL)	Pushing	112~115V
	Not Pushing	0~2V

	Resistance [Ω]
Pilot Valve	360~420
Water valve	360~420

Water mode doesn't work

1
Check the loose connection

2
Check the voltage.
(while pushing the lever S/W)
Is voltage correct?

No → Change the PCB

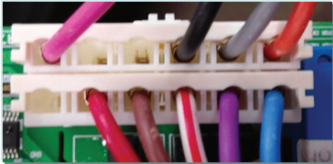

CON2

LEVER S/W	Voltage [V]	
	Pushing	Not Pushing
CON2 11 th pin ~ B(NEUTRAL)	112~115V	0~2V
	0~2V	112~115V
CON2 10 th pin ~ B(NEUTRAL)	112~115V	0~2V
	0~2V	112~115V

Yes →

3
Check the resistance value.
Is Pilot Valve resistance
360~420Ω?

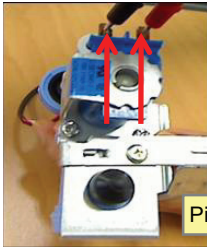

Pilot Valve

	Resistance [Ω]
Pilot Valve	360~420

No → Replace P/ Valve

Yes →

4
Check the resistance value.
Is Water Valve resistance
360~420Ω?

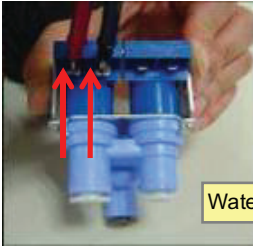

Water Valve

	Resistance [Ω]
Water valve	360~420

No → Replace Water Valve

Yes →

5
Explain to customer

8-16. Poor cooling in Fresh food section

Symptom	Check Point
1. Poor cooling in Fresh food section	1. Check the sensor resistance 2. Check the air flow 3. Check the air Temperature 4. Check the R-Fan motor voltage

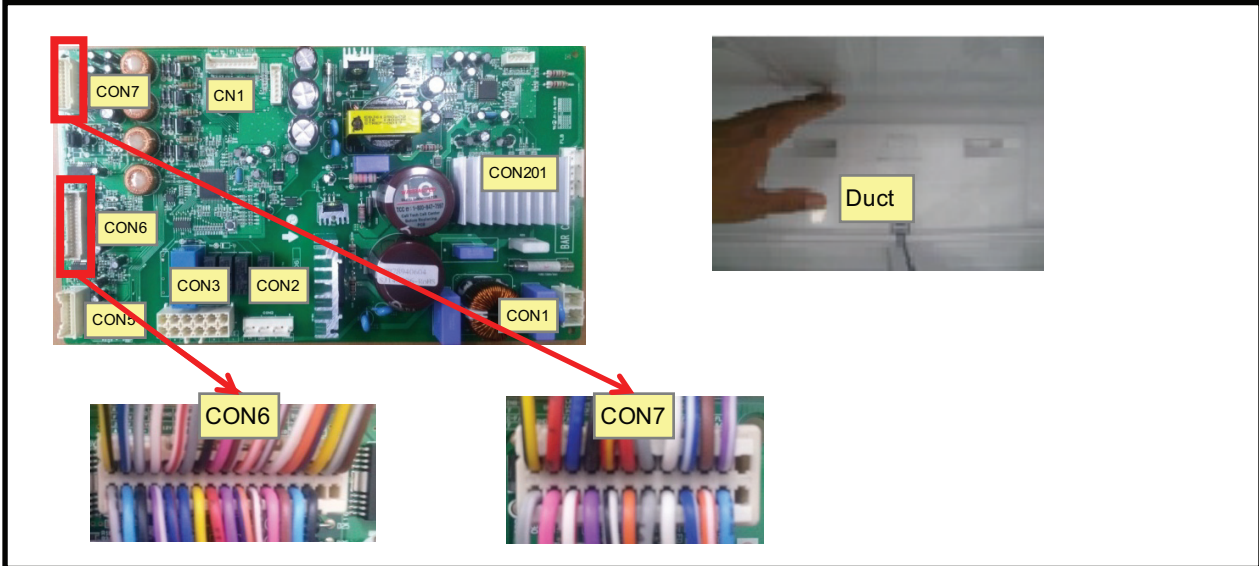

CON7 13 th pin ~ 14 th pin	Resistance [Ω]
23°F / -5°C	38k
32°F / 0°C	30k
41°F / 5°C	24k
50°F / 10°C	19.5k
59°F / 15°C	16k

TEST MODE 1	Voltage [V]
CON6 3 rd pin ~ 5 th pin	8~12V
CON6 1 st pin ~ 5 th pin	Not 0V, 5V

Duct	Status
Air Flow	Windy
Air Temperature	Cold

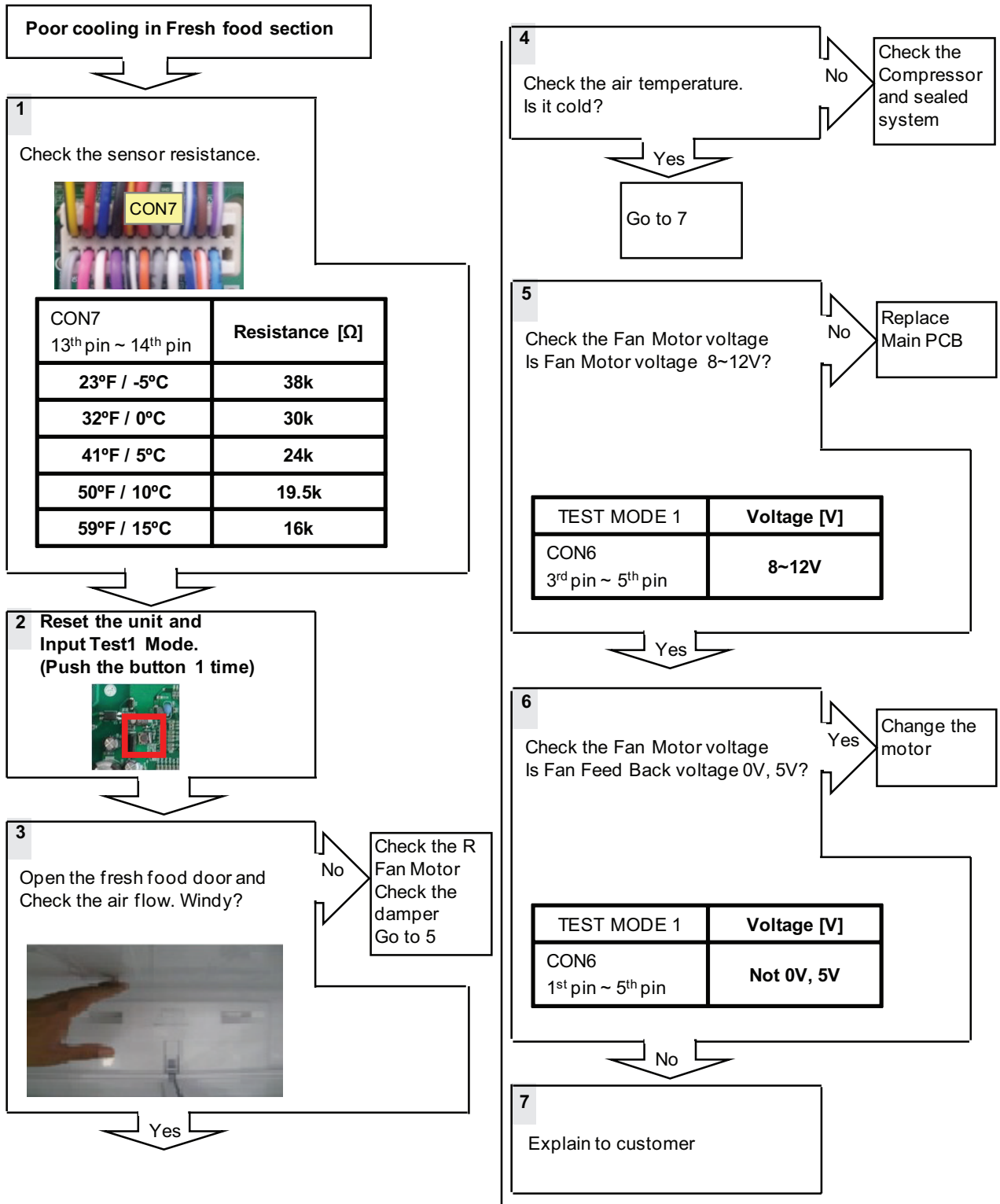

8-17. Refrigerator room lamp doesn't work

Symptom	Check Point
1. Refrigerator room lamp doesn't work	1. Check the Refrigerator door switch 2. Check the door S/W resistance 3. Check the LED Lamp

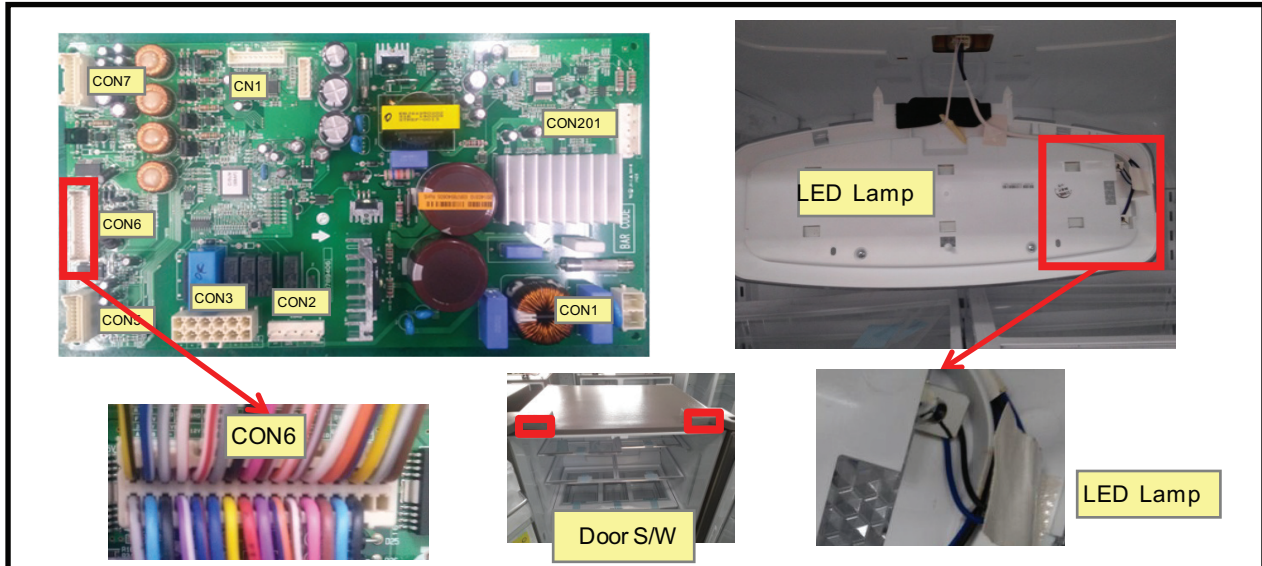

CON6 2 GYRD 4 YLRL 6 GY 8 PRWH 10 BLWR 3 BLWH 5 BK 1 YLBK 7 WHRD 9 WHRD 11 BK 12 BL 14 YL 16 RD 18 PR 19 BK 20 BCBK 21 BNWH 22 BNWH 24 PK 26 BN 25 BO 23 WH 15 GYWH 13 BK 28 SB 30 BK 32 BK 17 27 29 33 BK 31 WHBK	1 2 3,4 5 6 7 8 9 10 11 12 13 14 15 16 17 18 19 20 21 22 23 24 25 26 27 28 29 30 31 32 33 34	VALVE R-FAN MOTOR PANTRY-SENSOR PANTRY-DISPLAY H/F BOX MOTOR BETA DUCT HTR PANTRY STEPPING MOTOR FULL ROOM SIDE-R LED UTILITY HTR FLOW SNR SV GND FLOW SNR SIGNAL	<table border="1"> <thead> <tr> <th colspan="2">Resistance [Ω]</th> </tr> </thead> <tbody> <tr> <td rowspan="2">Door S/W</td> <td>Normal</td> <td>0</td> </tr> <tr> <td>Push S/W</td> <td>Infinity</td> </tr> </tbody> </table> <table border="1"> <thead> <tr> <th colspan="2">Voltage [V]</th> </tr> </thead> <tbody> <tr> <td>CON6 28th pin & 30th pin</td> <td>11.4~12.6V</td> </tr> </tbody> </table> <table border="1"> <thead> <tr> <th colspan="2">Voltage [V]</th> </tr> </thead> <tbody> <tr> <td rowspan="2">LED Lamp Blue & Black</td> <td>Closed</td> <td>0~2V</td> </tr> <tr> <td>Open</td> <td>11.4~12.6V</td> </tr> </tbody> </table>	Resistance [Ω]		Door S/W	Normal	0	Push S/W	Infinity	Voltage [V]		CON6 28 th pin & 30 th pin	11.4~12.6V	Voltage [V]		LED Lamp Blue & Black	Closed	0~2V	Open	11.4~12.6V
	Resistance [Ω]																				
Door S/W	Normal	0																			
	Push S/W	Infinity																			
Voltage [V]																					
CON6 28 th pin & 30 th pin	11.4~12.6V																				
Voltage [V]																					
LED Lamp Blue & Black	Closed	0~2V																			
	Open	11.4~12.6V																			

Refrigerator room lamp doesn't work

1

The Switch senses if the door is open or close.
When the door open, lamp On
When the door Close, lamp Off



Yes → Explain to customer

No → 2

2

Check the door S/W resistance.
Is it correct compared with table?

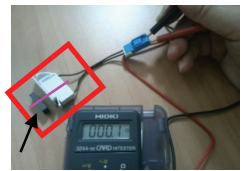

Resistance [Ω]		
Door S/W	No magnet near the switch	Infinity
	Magnet is near the switch	0

Yes → 3

No → Change the Door S/W

3

Check the PCB Voltage.
Is CON6 28th pin & 30th pin voltage 11.4~12.6V?
(While door open)



	Voltage [V]
CON6 28 th pin & 30 th pin	11.4~12.6V

Yes → 6

No → Change the PCB

4

Check the PCB Voltage.
Is CON6 28th pin & 30th pin voltage 0~2V?
(While door closed)



	Voltage [V]
CON6 28 th pin & 30 th pin	0~2V



Yes → 5

No → Change the PCB



5

Check the LED Lamp voltage
Is voltage 11.4 ~ 12.6V?
(While door open)

Top LED Lamp

Side LED Lamp

Yes → 6

No → Check LED Lamp Connection

6

Change the LED Lamp

8-18. Freezer lamp doesn't work

Symptom	Check Point
1. Freezer room lamp doesn't work	1. Check the freezer door switch 2. Check the door S/W resistance 3. Check the LED Lamp

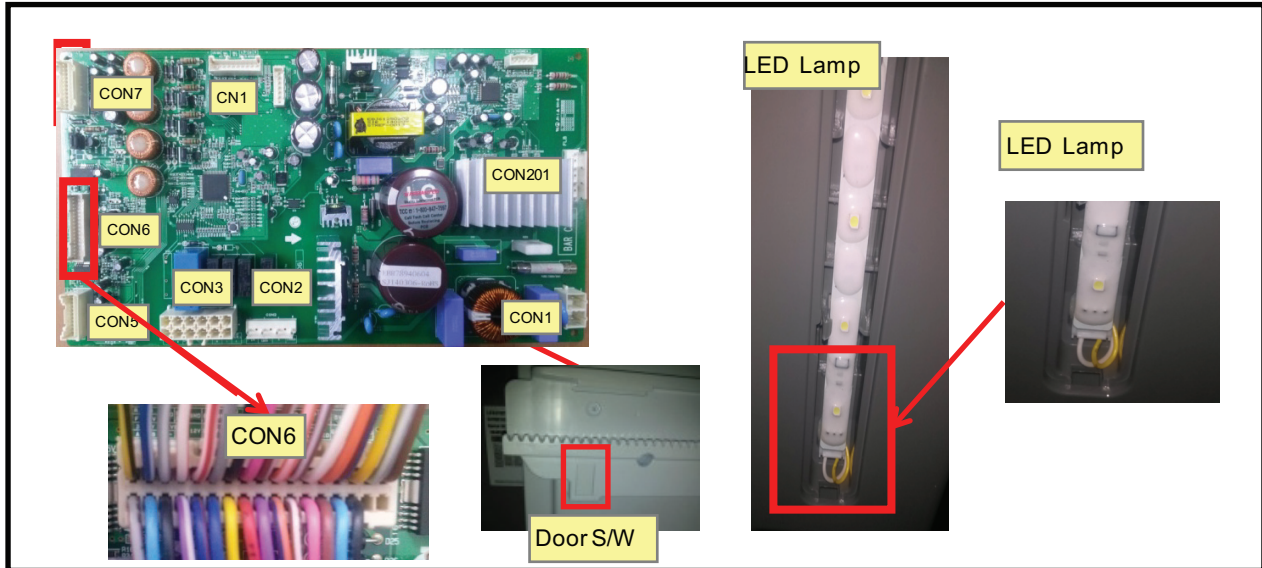

	Resistance [Ω]	
Door S/W	Normal	0
	Push S/W	Infinity

	Voltage [V]
CON6 13 th pin & 15 th pin	11.4~12.6V

LED Lamp	Voltage [V]	
White & Yellow	Closed	0~2V
	Open	11.4~12.6V

Refrigerator room lamp doesn't work

1

The Switch senses if the door is open or close.
When the door open, lamp On
When the door Close, lamp Off



Yes → Explain to customer

No → 2

2

Check the door S/W resistance.
Is it correct compared with table?

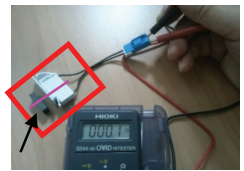

Resistance [Ω]		
Door S/W	No magnet near the switch	Infinity
	Magnet is near the switch	0

No → Change the Door S/W

Yes → 3

3

Check the PCB Voltage.
Is CON6 28th pin & 30th pin voltage 11.4~12.6V?
(While door open)



	Voltage [V]
CON6 28 th pin & 30 th pin	11.4~12.6V

No → Change the PCB

Yes → 4

4

Check the PCB Voltage.
Is CON6 28th pin & 30th pin voltage 0~2V?
(While door closed)



	Voltage [V]
CON6 28 th pin & 30 th pin	0~2V



No → Change the PCB

Yes → 5



5

Check the LED Lamp voltage
Is voltage 11.4 ~ 12.6V?
(While door open)

Top LED Lamp

Side LED Lamp

No → Check LED Lamp Connection

Yes → 6

6

Change the LED Lamp

8-19. Poor cooling in Freezer compartment

Symptom	Check Point
1. Poor cooling in Freezer compartment	1. Check the sensor resistance 2. Check the air flow 3. Check the air Temperature 4. Check the Fan motor sticky 4. Check the Fan motor voltage

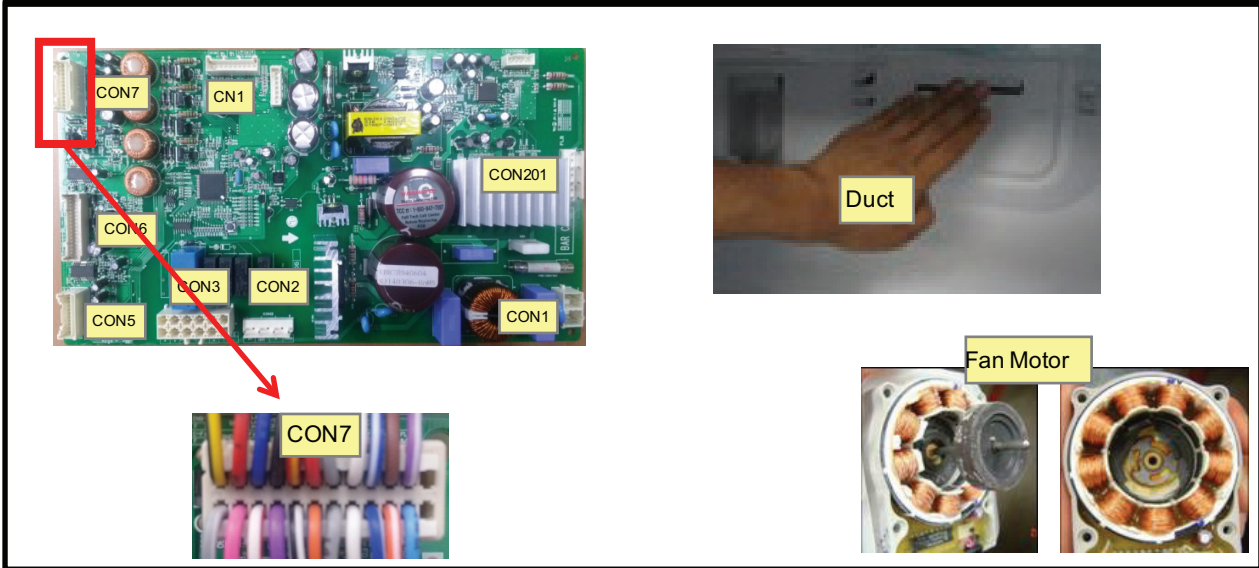

	<table border="1"> <thead> <tr> <th>CON7 19th pin & 20th pin</th> <th>Resistance [Ω]</th> </tr> </thead> <tbody> <tr> <td>-22°F / -30°C</td> <td>40k</td> </tr> <tr> <td>-13°F / -25°C</td> <td>30k</td> </tr> <tr> <td>-4°F / -20°C</td> <td>23k</td> </tr> <tr> <td>-13°F / -25°C</td> <td>17k</td> </tr> <tr> <td>14°F / -10°C</td> <td>13k</td> </tr> <tr> <td>23°F / -5°C</td> <td>10k</td> </tr> <tr> <td>32°F / 0°C</td> <td>8k</td> </tr> </tbody> </table>	CON7 19 th pin & 20 th pin	Resistance [Ω]	-22°F / -30°C	40k	-13°F / -25°C	30k	-4°F / -20°C	23k	-13°F / -25°C	17k	14°F / -10°C	13k	23°F / -5°C	10k	32°F / 0°C	8k
	CON7 19 th pin & 20 th pin	Resistance [Ω]															
	-22°F / -30°C	40k															
	-13°F / -25°C	30k															
	-4°F / -20°C	23k															
	-13°F / -25°C	17k															
	14°F / -10°C	13k															
23°F / -5°C	10k																
32°F / 0°C	8k																
<table border="1"> <thead> <tr> <th>TEST MODE 1</th> <th>Voltage [V]</th> </tr> </thead> <tbody> <tr> <td>CON7 10^h pin & 12th pin</td> <td>8~12V</td> </tr> <tr> <td>CON7 8th pin & 12th pin</td> <td>Not 0V, 5V</td> </tr> </tbody> </table>	TEST MODE 1	Voltage [V]	CON7 10 ^h pin & 12 th pin	8~12V	CON7 8 th pin & 12 th pin	Not 0V, 5V											
TEST MODE 1	Voltage [V]																
CON7 10 ^h pin & 12 th pin	8~12V																
CON7 8 th pin & 12 th pin	Not 0V, 5V																
<table border="1"> <tbody> <tr> <td>Duct</td> <td>Status</td> </tr> <tr> <td>Air Flow</td> <td>Windy</td> </tr> <tr> <td>Air Temperature</td> <td>Cold</td> </tr> </tbody> </table>	Duct	Status	Air Flow	Windy	Air Temperature	Cold											
Duct	Status																
Air Flow	Windy																
Air Temperature	Cold																

Poor cooling in Freezer compartment

1

Check the sensor resistance.

CON7 19 th pin ~ 20 th pin	Resistance [Ω]
-22°F / -30°C	40k
-13°F / -25°C	30k
-4°F / -20°C	23k
-13°F / -25°C	17k
14°F / -10°C	13k
23°F / -5°C	10k
32°F / 0°C	8k

2 Reset the unit and Input Test1 Mode. (Push the button 1 time)

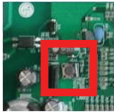

3 Open the Freezer door and Check the air flow. Windy?



No
Check the F Fan Motor
Go to 5

Yes

4

Check the air temperature. Is it cold?

No

Check the Compressor and sealed system

Yes

5

Check the Fan motor. Rotate fan using hand. It feel sticky?

Yes

Change the Fan motor

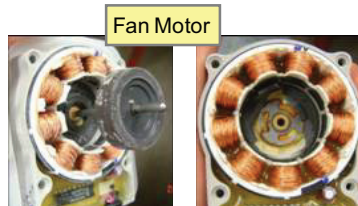

No

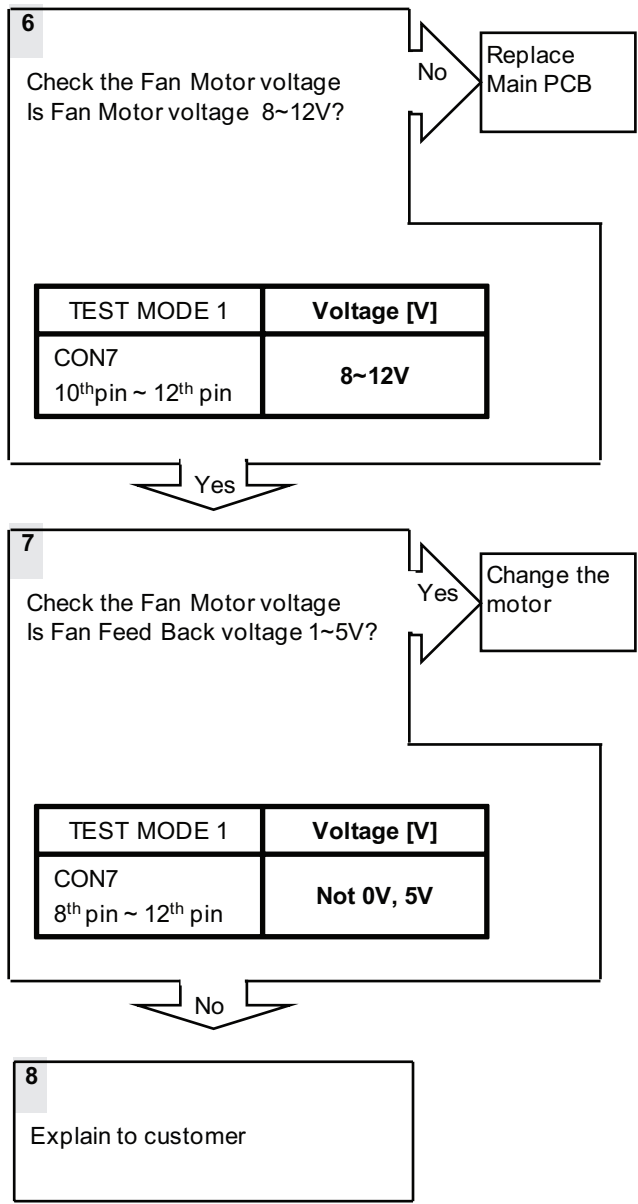

8-20. Wi-Fi Modem Error (E Od)

Symptom	Check Point
1. E Od	1. Check the loose connection 2. Check the voltage

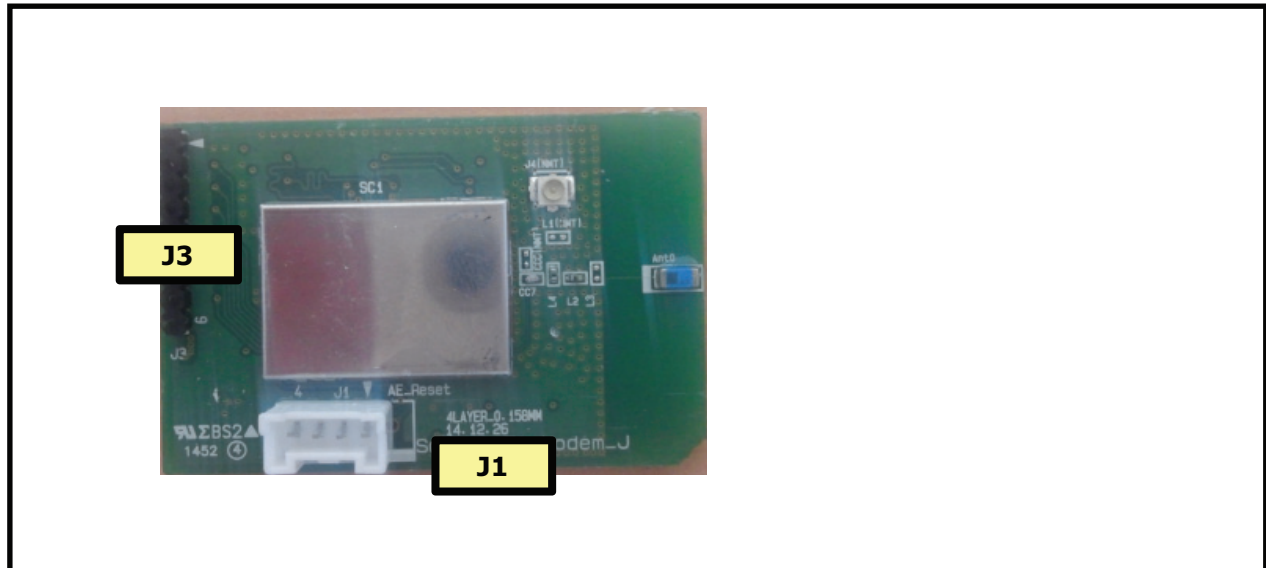

WiFi Modem Error (E Od)

1
Check the loose connection

2
Check the voltage.
Is J1 1st pin ~ 4th pin voltage 5V?

	Voltage[v]
J1 1 st pin~4 th pin	5V

No → Change the Display PCB

Yes →

3
Check the voltage.
Is J3 1stpin ~ 9thpin voltage 3.3V?

	Voltage[v]
J3 1 st pin~9 th pin	3.3V

No → Change the WiFi Modem

Yes →

4
Check the Error.
Is it the WiFi Modem Error ?

Yes → Change the WiFi Modem And Display PCB

NO →

5
Explain to customer

9. Reference

9. TEST MODE and Removing TPA

1. How to make TEST MODE

If you push the test button on the Main PCB, the refrigerator will be enter the TEST MODE.

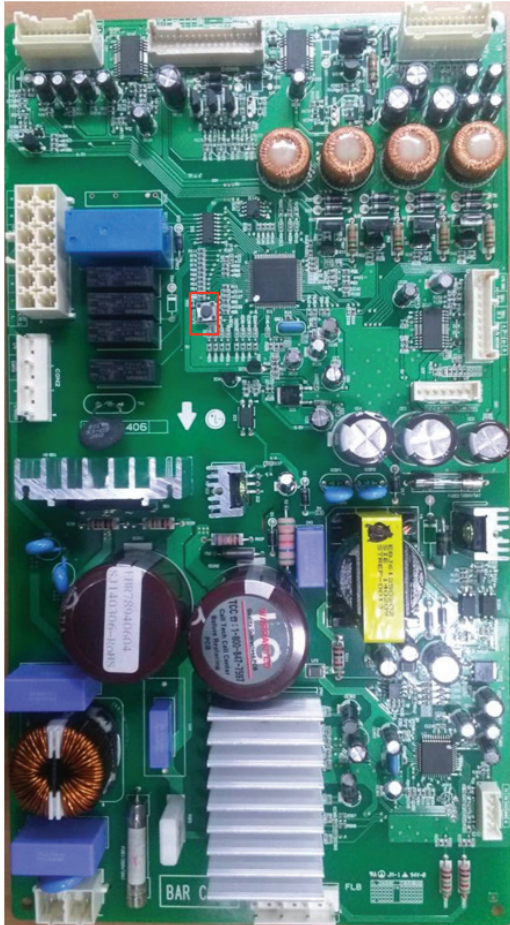

Main PCB

* 1 time : Comp / Damper / All FAN on
(All things displayed)

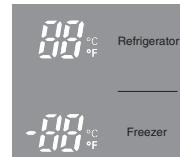

* 2 times : Damper closed
(22 22 displayed)

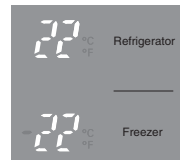

* 3 times : Forced defrost mode
(33 33 displayed)



2. How to remove Terminal Position Assurance (TPA)

<AC TPA>

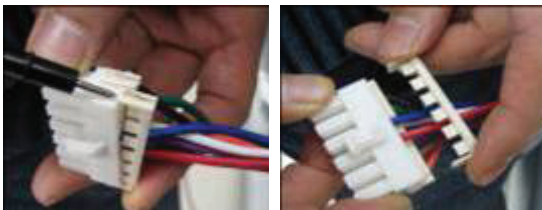

<DC TPA>

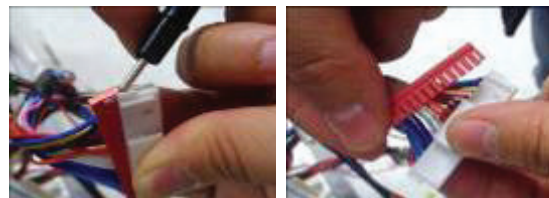

After measure the values, you should put in the TPA again.

9-2 TEMPERATRUE CHART - FREEZER AND ICING SENSOR



TEMP	RESISTANCE	VOLTAGE
-39°F (-40°C)	73.29	4.09 V
-30°F (-35°C)	53.63	3.84 V
-30°F (-21°C)	39.66	3.55 V
-13°F (-25°C)	29.62	3.23 V
-4°F (-20°C)	22.33	2.89 V
5°F (-15°C)	16.99	2.56 V
14°F (-10°C)	13.05	2.23 V
23°F (-5°C)	10.10	1.92 V
32°F (0°C)	7.88	1.63 V
41°F (+5°C)	6.19	1.38 V
50°F (+10°C)	4.91	1.16 V
59°F (+15°C)	3.91	0.97 V
68°F (+20°C)	3.14	0.81 V
77°F (+25°C)	2.54	0.67 V
86°F (+30°C)	2.07	0.56 V
95°F (+35°C)	1.69	0.47 V
104°F (+40°C)	1.39	0.39 V

9-3 TEMPERATRUE CHART - REFRIGERATOR AND DEFROST SENSOR

TEMP	RESISTANCE	VOLTAGE
-39°F (-40°C)	225.1	4.48 V
-30°F (-35°C)	169.8	4.33 V
-30°F (-21°C)	129.3	4.16 V
-13°F (-25°C)	99.30	3.95 V
-4°F (-20°C)	76.96	3.734 V
5°F (-15°C)	60.13	3.487 V
14°F (-10°C)	47.34	3.22 V
23°F (-5°C)	37.55	2.95 V
32°F (0°C)	30	2.67 V
41°F (+5°C)	24.13	2.40 V
50°F (+10°C)	19.53	2.14 V
59°F (+15°C)	15.91	1.89 V
68°F (+20°C)	13.03	1.64 V
77°F (+25°C)	10.74	1.45 V
86°F (+30°C)	8.89	1.27 V
95°F (+35°C)	7.40	1.10 V
104°F (+40°C)	6.20	0.96 V

10. COMPONENT TESTING INFORMATION

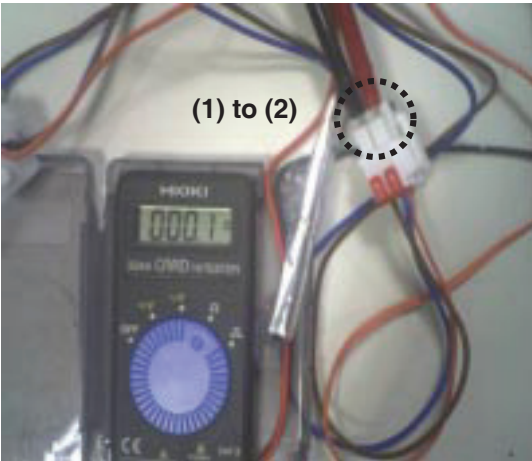
10-1 Defrost Controller Assembly

<p>Function</p>	<p>The controller assembly is made up of two different kinds of parts. The fuse and the sensor. To determine if these parts are defective, check for resistance. The fuse will cut power to the defrost heater at very high temperatures.</p>													
<p>How to Measure (Fuse-M)</p>		<p>Set a ohmmeter to the 2 housing pin. Measure the 2 pin connected to Fuse-M. If the ohmmeter indicate below 0.1ohm fuse-m is a good condition, But if infinite the part is bad.</p>												
<p>How to Measure (Sensor)</p>		<p>Set a ohmmeter to The 2housing pin. Measure the 2 pin connected to Sensor. If the ohmmeter indicate 11 (at room temperature) Sensor is good. When check the ohm at other temperatures Check the sensor manual.</p>												
<p>Standard</p>	<table border="1" style="margin-left: auto; margin-right: auto;"> <thead> <tr> <th colspan="2">Fuse-M (at all temperature)</th> </tr> <tr> <th>Test Point</th> <th>Ressult</th> </tr> </thead> <tbody> <tr> <td>(1) to (2)</td> <td>0 ~ 0.1</td> </tr> </tbody> </table>	Fuse-M (at all temperature)		Test Point	Ressult	(1) to (2)	0 ~ 0.1	<table border="1" style="margin-left: auto; margin-right: auto;"> <thead> <tr> <th colspan="2">Sensor (at room temperature)</th> </tr> <tr> <th>Test Point</th> <th>Ressult</th> </tr> </thead> <tbody> <tr> <td>(1) to (2)</td> <td>11</td> </tr> </tbody> </table>	Sensor (at room temperature)		Test Point	Ressult	(1) to (2)	11
Fuse-M (at all temperature)														
Test Point	Ressult													
(1) to (2)	0 ~ 0.1													
Sensor (at room temperature)														
Test Point	Ressult													
(1) to (2)	11													

10-2 Sheath Heater (Freezer Room)

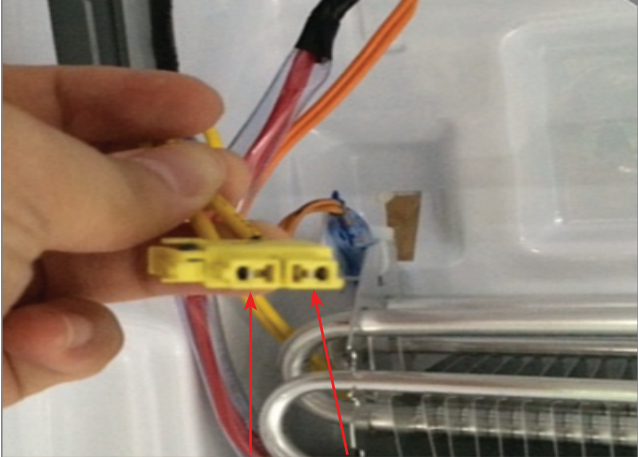
<p>Function</p>	<p>Sheath heater is the part for defrost. All heating wire is connected to only one line. So we can decide part is defective or not when we check the resistance.</p>				
<p>How to Measure</p>	<div style="display: flex; justify-content: space-around;">   </div> <p style="text-align: center;">(1) (2)</p> <p>Set a ohmmeter connect to The housing pins. Measure the pins connected to Sheath Heater. If the ohmmeter indicates $(V \times V) / P = R$ (V=voltage, P=watt, R=Resistance) is on a good condition, ex) watt=200W, voltage=115V $R = (115 \times 115) / 200 = 66$ Infinitive value implies sheath heater is disconnected.</p>				
<p>Standard</p>	<p style="text-align: center;">Sheath heater (at all temperature)</p> <table border="1" style="margin-left: auto; margin-right: auto;"> <thead> <tr> <th>Test Point</th> <th>Ressult</th> </tr> </thead> <tbody> <tr> <td>(1) to (2)</td> <td>62 ~ 70</td> </tr> </tbody> </table>	Test Point	Ressult	(1) to (2)	62 ~ 70
Test Point	Ressult				
(1) to (2)	62 ~ 70				

10-3 Sheath Heater (Freezer Room)

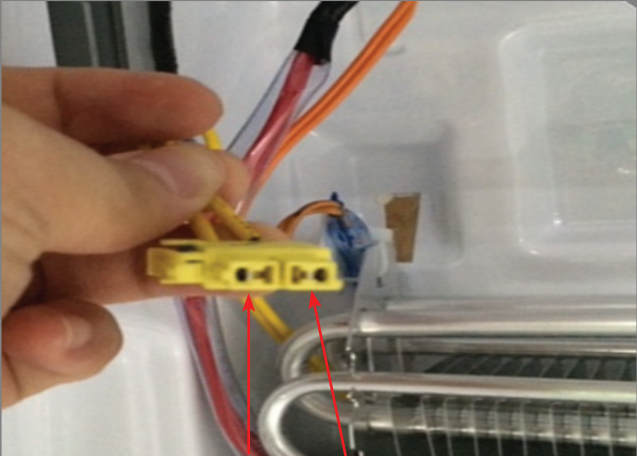

<p>Function</p>	<p>Sheath heater is the part for defrost. All heating wire is connected to only one line. So we can decide part is defective or not when we check the resistance.</p>				
<p>How to Measure</p>	<div style="display: flex; justify-content: space-around;">   </div> <p style="text-align: center;">(1) (2)</p> <p>Set a ohmmeter connect to The housing pins. Measure the pins connected to Sheath Heater. If the ohmmeter indicates $(V \times V) / P = R$ (V=voltage, P=watt, R=Resistance) is on a good condition, ex) watt=200W, voltage=115V $R = (115 \times 115) / 200 = 66$ Infinitive value implies sheath heater is disconnected.</p>				
<p>Standard</p>	<p>Sheath heater (at all temperature)</p> <table border="1" style="margin-left: auto; margin-right: auto;"> <thead> <tr> <th>Test Point</th> <th>Ressult</th> </tr> </thead> <tbody> <tr> <td>(1) to (2)</td> <td>62 ~ 70</td> </tr> </tbody> </table>	Test Point	Ressult	(1) to (2)	62 ~ 70
Test Point	Ressult				
(1) to (2)	62 ~ 70				

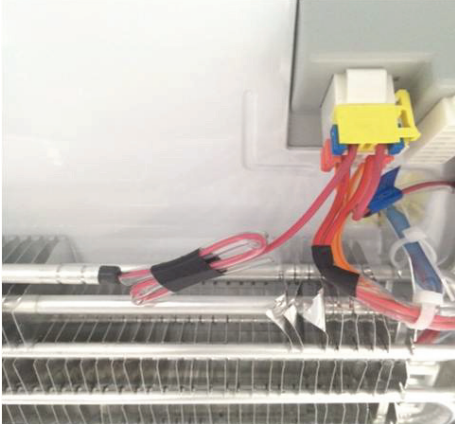
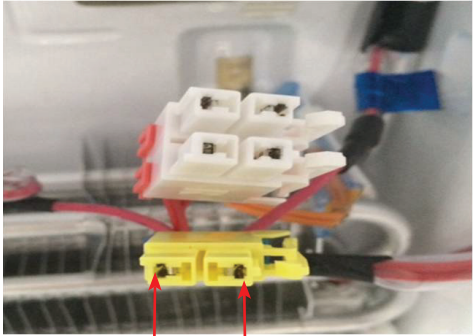

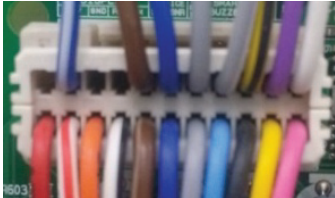

10-4 L-cord Heater (Refrigerator Room)

<p>Function</p>	<p>L-cord heater is the part for defrost. All heating wire is connected to only one line. So we can decide part is defective or not when we check the resistance.</p>				
<p>How to Measure</p>	<div style="display: flex; justify-content: space-around; align-items: center;">   </div> <p style="text-align: center;">(1) (2)</p> <p>Set a ohmmeter connect to The housing pins. Measure the pins connected to Sheath Heater. If the ohmmeter indicates $(V \times V) / P = R$ (V=voltage, P=Watt, R=Resistance) is on a good condition, ex) watt=130W, voltage=120V $R = (120 \times 120) / 130 = 111$ Infinitive value implies sheath heater is disconnected.</p>				
<p>Standard</p>	<p style="text-align: center;">L-cord Heater (at all temperature)</p> <table border="1" style="margin-left: auto; margin-right: auto;"> <thead> <tr> <th>Test Point</th> <th>Ressult</th> </tr> </thead> <tbody> <tr> <td>(1) to (2)</td> <td>103~119</td> </tr> </tbody> </table>	Test Point	Ressult	(1) to (2)	103~119
Test Point	Ressult				
(1) to (2)	103~119				

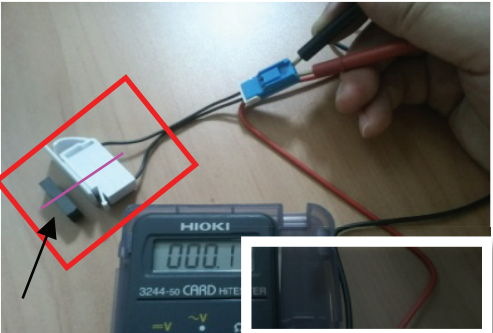
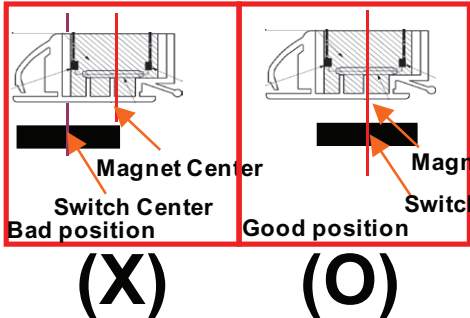

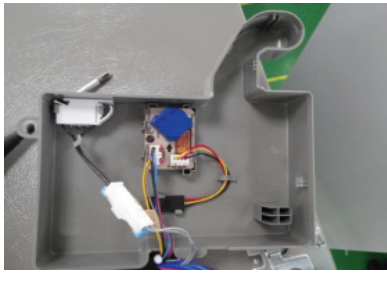
10-5 Door Switch

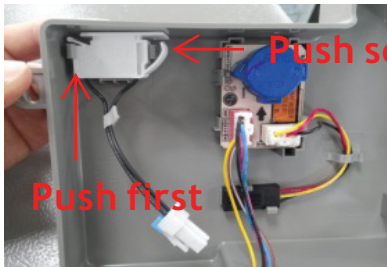
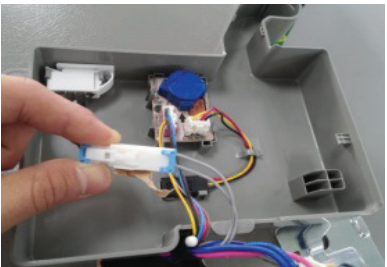





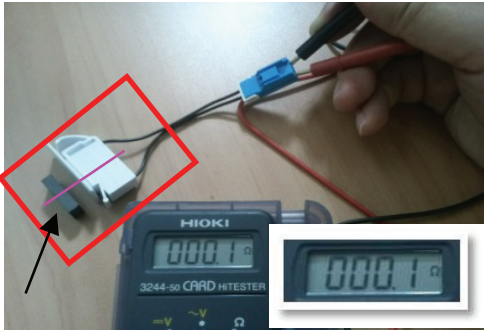
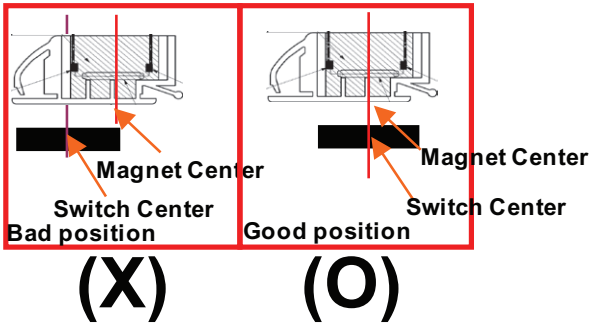

10-5-1 Door Switch,R

No.	Checking Flow	Result & SVC Action																		
1	<p>▶ Check Reed Switch</p> 	<p>The Switch senses if the door is open or close. .When the door open, lamp On .When the door Close, lamp Off</p> <p>※ close Door and check the lamp Through the gap</p>																		
2	<p>▶ Check Voltage between pin 13 and 14</p>  <p>CON5</p>	<table border="1"> <thead> <tr> <th>Status</th> <th>Result</th> <th>SVC Action</th> </tr> </thead> <tbody> <tr> <td>In case of Door Close</td> <td>1V ↑</td> <td>1.Check Reed S/W 2.Check Harness disconnection 3.If No.1,2 ok ,change PCB</td> </tr> <tr> <td>In case of Door Open</td> <td>0V</td> <td>1.Check Reed S/W 2.Check Harness disconnection 3.If No.1,2 ok ,change PCB</td> </tr> </tbody> </table>	Status	Result	SVC Action	In case of Door Close	1V ↑	1.Check Reed S/W 2.Check Harness disconnection 3.If No.1,2 ok ,change PCB	In case of Door Open	0V	1.Check Reed S/W 2.Check Harness disconnection 3.If No.1,2 ok ,change PCB									
Status	Result	SVC Action																		
In case of Door Close	1V ↑	1.Check Reed S/W 2.Check Harness disconnection 3.If No.1,2 ok ,change PCB																		
In case of Door Open	0V	1.Check Reed S/W 2.Check Harness disconnection 3.If No.1,2 ok ,change PCB																		
3	<p>▶ Check the Reed S/W resistance</p> <p>-No Magnet</p>  <p>-Magnet Near the Switch</p> 	<p>-Magnet must be center of Switch</p>  <p>(X) (O)</p> <p>-Resistance & Service Action</p> <table border="1"> <thead> <tr> <th>Status</th> <th>Resistance</th> <th>Result</th> <th>SVC Action</th> </tr> </thead> <tbody> <tr> <td rowspan="2">No magnet near the Switch</td> <td>$\infty \Omega$</td> <td>O.K.</td> <td>Go to 2</td> </tr> <tr> <td>$10 \Omega \downarrow$</td> <td>N.G.</td> <td>Go to 4</td> </tr> <tr> <td rowspan="2">Magnet is near the Switch</td> <td>$1 \Omega \downarrow$</td> <td>O.K.</td> <td>Go to 2</td> </tr> <tr> <td>$10 \Omega \uparrow$</td> <td>N.G.</td> <td>Go to 4</td> </tr> </tbody> </table>	Status	Resistance	Result	SVC Action	No magnet near the Switch	$\infty \Omega$	O.K.	Go to 2	$10 \Omega \downarrow$	N.G.	Go to 4	Magnet is near the Switch	$1 \Omega \downarrow$	O.K.	Go to 2	$10 \Omega \uparrow$	N.G.	Go to 4
Status	Resistance	Result	SVC Action																	
No magnet near the Switch	$\infty \Omega$	O.K.	Go to 2																	
	$10 \Omega \downarrow$	N.G.	Go to 4																	
Magnet is near the Switch	$1 \Omega \downarrow$	O.K.	Go to 2																	
	$10 \Omega \uparrow$	N.G.	Go to 4																	



No.	Checking Flow	Result & SVC Action
4	<p>► Change Reed S/W -. Remove screw</p>	
	<p>-. Disassemble Housing</p>	
	<p>-. Check Resistance of Reed S/W. if it is NG, change it(Number3)</p>	
	<p>-. Assemble Reed S/W to hinge cover and Assemble Reed S/W Housing</p>	
	<p>-. Assemble Screw to hinge cover</p>	
	<p>-. Assemble Screw to hinge cover</p>	





10-5-2 Door Switch,F

No.	Checking Flow	Result & SVC Action																		
1	<p>▶ Check the Freezer door switch</p> 	<p>The Switch senses if the door is open or close. .When the door open, lamp On .When the door Close, lamp Off</p> <p>※ close Door and check the lamp Through the gap</p>																		
2	<p>▶ Check Voltage between pin 21 and 22</p> 	<table border="1"> <thead> <tr> <th>Status</th> <th>Result</th> <th>SVC Action</th> </tr> </thead> <tbody> <tr> <td>In case of Door Close</td> <td>1V ↑</td> <td>1.Check Reed S/W 2.Check Harness disconnection 3.If No.1,2 ok ,change PCB</td> </tr> <tr> <td>In case of Door Open</td> <td>0V</td> <td>1.Check Reed S/W 2.Check Harness disconnection 3.If No.1,2 ok ,change PCB</td> </tr> </tbody> </table>	Status	Result	SVC Action	In case of Door Close	1V ↑	1.Check Reed S/W 2.Check Harness disconnection 3.If No.1,2 ok ,change PCB	In case of Door Open	0V	1.Check Reed S/W 2.Check Harness disconnection 3.If No.1,2 ok ,change PCB									
Status	Result	SVC Action																		
In case of Door Close	1V ↑	1.Check Reed S/W 2.Check Harness disconnection 3.If No.1,2 ok ,change PCB																		
In case of Door Open	0V	1.Check Reed S/W 2.Check Harness disconnection 3.If No.1,2 ok ,change PCB																		
3	<p>▶ Check the Reed S/W resistance</p> <p>-No Magnet</p>  <p>-Magnet Near the Switch</p> 	<p>-Magnet must be center of Switch</p>  <p>-Resistance & Service Action</p> <table border="1"> <thead> <tr> <th>Status</th> <th>Resistance</th> <th>Result</th> <th>SVC Action</th> </tr> </thead> <tbody> <tr> <td rowspan="2">No magnet near the Switch</td> <td>$\infty \Omega$</td> <td>O.K.</td> <td>Go to 2</td> </tr> <tr> <td>$10 \Omega \downarrow$</td> <td>N.G.</td> <td>Go to 4</td> </tr> <tr> <td rowspan="2">Magnet is near the Switch</td> <td>$1 \Omega \downarrow$</td> <td>O.K.</td> <td>Go to 2</td> </tr> <tr> <td>$10 \Omega \uparrow$</td> <td>N.G.</td> <td>Go to 4</td> </tr> </tbody> </table>	Status	Resistance	Result	SVC Action	No magnet near the Switch	$\infty \Omega$	O.K.	Go to 2	$10 \Omega \downarrow$	N.G.	Go to 4	Magnet is near the Switch	$1 \Omega \downarrow$	O.K.	Go to 2	$10 \Omega \uparrow$	N.G.	Go to 4
Status	Resistance	Result	SVC Action																	
No magnet near the Switch	$\infty \Omega$	O.K.	Go to 2																	
	$10 \Omega \downarrow$	N.G.	Go to 4																	
Magnet is near the Switch	$1 \Omega \downarrow$	O.K.	Go to 2																	
	$10 \Omega \uparrow$	N.G.	Go to 4																	

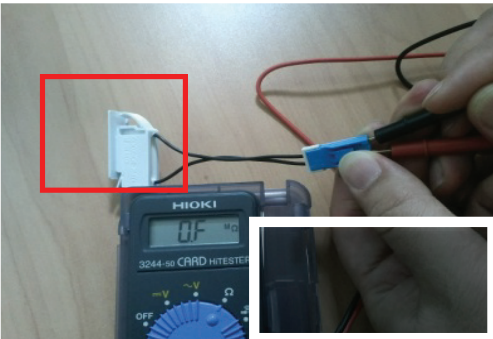
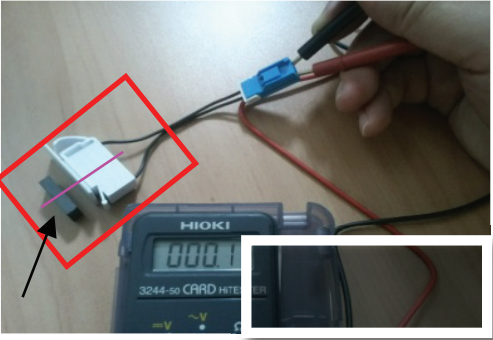
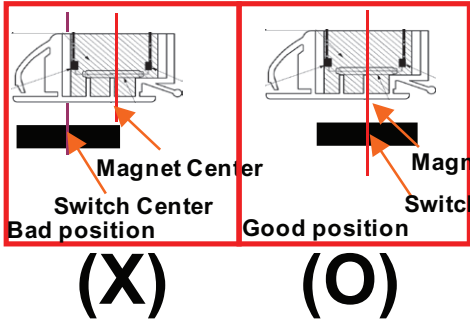
No.	Checking Flow	Result & SVC Action
4	<p>▶ Change Reed S/W -. Remove 3 screw and divide housing</p> 	
	<p>-. Divide Reed S/W</p> 	
	<p>-.Push the part of hook and divide Reed S/W -.Check the Reed S/W resistance and if it is NG. Change it (Number 3)</p>	
	<p>-.Push the Reed S/W to direction of the arrow</p>	
		
	<p>-. Assemble 3 Screw after Assemble Reed Switch housing</p> 	

10-5-3 H/Bar Door Switch

No.	Checking Flow	Result & SVC Action																		
1	<p>▶ Check Reed Switch</p> 	<p>The Switch senses if the door is open or close. .When the door open, lamp On .When the door Close, lamp Off</p> <p>※ Close Door and check the lamp through the gap</p>																		
2	<p>▶ Check Voltage between pin 13 and 14</p> 	<table border="1"> <tr> <td data-bbox="854 783 1032 853">In case of Door Close</td> <td data-bbox="1032 783 1122 853">1V ↑</td> <td data-bbox="1122 783 1414 853">1.Check Reed S/W 2.Check Harness disconnection 3.If No.1,2 ok ,change PCB</td> </tr> <tr> <td data-bbox="854 853 1032 923">In case of Door Open</td> <td data-bbox="1032 853 1122 923">0V</td> <td data-bbox="1122 853 1414 923">1.Check Reed S/W 2.Check Harness disconnection 3.If No.1,2 ok ,change PCB</td> </tr> </table>	In case of Door Close	1V ↑	1.Check Reed S/W 2.Check Harness disconnection 3.If No.1,2 ok ,change PCB	In case of Door Open	0V	1.Check Reed S/W 2.Check Harness disconnection 3.If No.1,2 ok ,change PCB												
In case of Door Close	1V ↑	1.Check Reed S/W 2.Check Harness disconnection 3.If No.1,2 ok ,change PCB																		
In case of Door Open	0V	1.Check Reed S/W 2.Check Harness disconnection 3.If No.1,2 ok ,change PCB																		
3	<p>▶ Check the Reed S/W resistance</p> <p>-.No Magnet</p>  <p>-.Magnet Near the Switch</p> 	<p>-.Magnet must be center of Switch</p>  <p>-.Resistance & Service Action</p> <table border="1"> <thead> <tr> <th data-bbox="894 1502 1057 1544">Status</th> <th data-bbox="1057 1502 1187 1544">Resistance</th> <th data-bbox="1187 1502 1276 1544">Result</th> <th data-bbox="1276 1502 1406 1544">SVC Action</th> </tr> </thead> <tbody> <tr> <td data-bbox="894 1544 1057 1640" rowspan="2">No magnet near the Switch</td> <td data-bbox="1057 1544 1187 1587">$\infty \Omega$</td> <td data-bbox="1187 1544 1276 1587">O.K.</td> <td data-bbox="1276 1544 1406 1587">Go to 2</td> </tr> <tr> <td data-bbox="1057 1587 1187 1640">$10 \Omega \downarrow$</td> <td data-bbox="1187 1587 1276 1640">N.G.</td> <td data-bbox="1276 1587 1406 1640">Go to 4</td> </tr> <tr> <td data-bbox="894 1640 1057 1736" rowspan="2">Magnet is near the Switch</td> <td data-bbox="1057 1640 1187 1683">$1 \Omega \downarrow$</td> <td data-bbox="1187 1640 1276 1683">O.K.</td> <td data-bbox="1276 1640 1406 1683">Go to 2</td> </tr> <tr> <td data-bbox="1057 1683 1187 1736">$10 \Omega \uparrow$</td> <td data-bbox="1187 1683 1276 1736">N.G.</td> <td data-bbox="1276 1683 1406 1736">Go to 4</td> </tr> </tbody> </table>	Status	Resistance	Result	SVC Action	No magnet near the Switch	$\infty \Omega$	O.K.	Go to 2	$10 \Omega \downarrow$	N.G.	Go to 4	Magnet is near the Switch	$1 \Omega \downarrow$	O.K.	Go to 2	$10 \Omega \uparrow$	N.G.	Go to 4
Status	Resistance	Result	SVC Action																	
No magnet near the Switch	$\infty \Omega$	O.K.	Go to 2																	
	$10 \Omega \downarrow$	N.G.	Go to 4																	
Magnet is near the Switch	$1 \Omega \downarrow$	O.K.	Go to 2																	
	$10 \Omega \uparrow$	N.G.	Go to 4																	

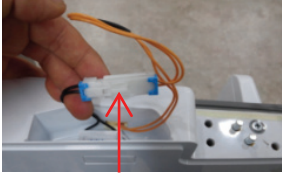
No.	Checking Flow	Result & SVC Action
4	<p>▶ Change Reed S/W</p> <ul style="list-style-type: none"> - . Remove screw(8EA)  <ul style="list-style-type: none"> - . Disassemble R/L Door  <ul style="list-style-type: none"> - . Remove screw(1EA)  <ul style="list-style-type: none"> - . Disassemble Cap Deco  <ul style="list-style-type: none"> - . Push Hook and Disassemble Housing  <ul style="list-style-type: none"> - . Check the Reed S/W resistance and if it is NG, Change it (Number 3) - . Assemble in reverse order how to disassemble 	

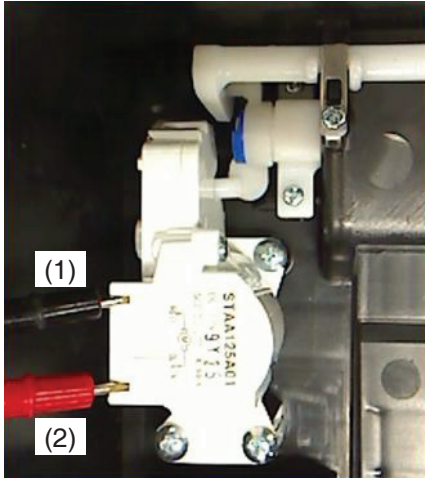

10-6 Dispenser DC Motor

Function	- Dispenser DC Motor : When customer push the dispenser button, Pull duct door				
How to Measure	<div style="text-align: center;">  <p>Dispenser DC Motor</p> </div>				
Standard	<p style="text-align: center;">Dispenser DC Motor</p> <table border="1" style="margin-left: auto; margin-right: auto;"> <thead> <tr> <th>Test Points</th> <th>Result</th> </tr> </thead> <tbody> <tr> <td>(1) to (2)</td> <td>9.9 ~ 12.1</td> </tr> </tbody> </table>	Test Points	Result	(1) to (2)	9.9 ~ 12.1
Test Points	Result				
(1) to (2)	9.9 ~ 12.1				

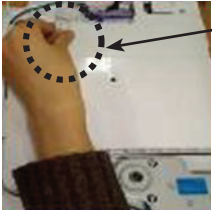
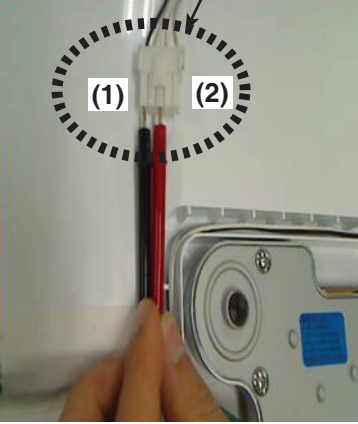
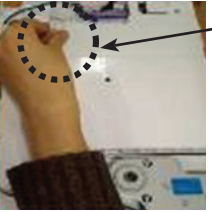
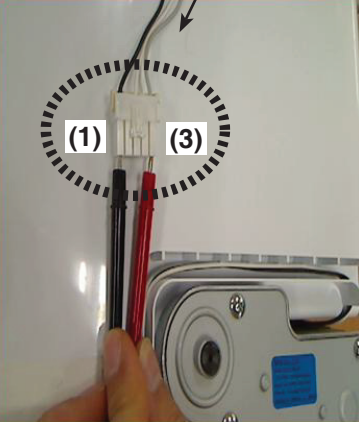

10-7 AC Motor ASSEMBLY

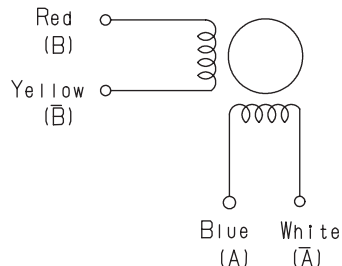
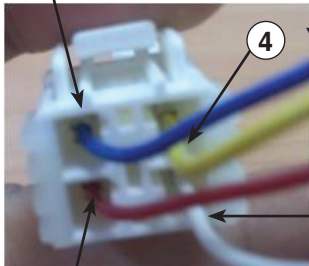
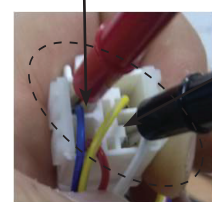
<p>Function</p>	<p>The motor in the door pushed the ice into the dispenser.</p>									
<p>How to Measure</p>	<p>< In-door Motor ></p>  <p>① Separate the housing.</p>  <p>② Measure the resistance between (1) and (2)</p>	<p>< In-door Motor ></p>  <p>① Separate the housing.</p>  <p>② Measure the resistance between (1) and (3)</p> <p>Check the resistance between connectors (In-door motor 1, 2) and (In-door motor 1, 3). It means check whether or not applying an Electric current. If there is resistance, it means the geared motor or solenoid is not inferiority</p>								
<p>Standard</p>	<p style="text-align: center;">Geared Motor</p> <table border="1" style="margin-left: auto; margin-right: auto;"> <thead> <tr> <th>Test Points</th> <th>Result</th> </tr> </thead> <tbody> <tr> <td>(1) to (2)</td> <td>31.1 ~ 42.09</td> </tr> </tbody> </table>	Test Points	Result	(1) to (2)	31.1 ~ 42.09	<p style="text-align: center;">Cube Solenoid</p> <table border="1" style="margin-left: auto; margin-right: auto;"> <thead> <tr> <th>Test Points</th> <th>Result</th> </tr> </thead> <tbody> <tr> <td>(1) to (3)</td> <td>31.1 ~ 42.09</td> </tr> </tbody> </table>	Test Points	Result	(1) to (3)	31.1 ~ 42.09
Test Points	Result									
(1) to (2)	31.1 ~ 42.09									
Test Points	Result									
(1) to (3)	31.1 ~ 42.09									

10-8 Damper

<p>Function</p>	<p>The damper supplies cold air from the freezer to the chill room using the damper plate. The chill room is colder when the damper plate is open. When the damper is closed the chill rooms temperature will rise.</p>																														
<p>How to Measure</p>	<div style="display: flex; justify-content: space-around;"> <div data-bbox="349 489 836 883" style="border: 1px dashed black; padding: 5px;"> <p>Table(1): 결선도(Wiring)</p>  </div> <div data-bbox="844 489 1453 883" style="border: 1px dashed black; padding: 5px;"> <p>Table(2): 2-2상 여자순서(CW Rotation)</p> <table border="1" style="width: 100%; border-collapse: collapse; text-align: center;"> <thead> <tr> <th rowspan="2">Housing No. & L/Wire Color</th> <th colspan="4">Step</th> </tr> <tr> <th>1</th> <th>2</th> <th>3</th> <th>4</th> </tr> </thead> <tbody> <tr> <td>1- Blue (A)</td> <td>+</td> <td>-</td> <td>-</td> <td>+</td> </tr> <tr> <td>2- Red (B)</td> <td>+</td> <td>+</td> <td>-</td> <td>-</td> </tr> <tr> <td>3- White(A)</td> <td>-</td> <td>+</td> <td>+</td> <td>-</td> </tr> <tr> <td>4- Yellow(B)</td> <td>-</td> <td>-</td> <td>+</td> <td>+</td> </tr> </tbody> </table> </div> </div> <p style="text-align: center;">< Damper Circuit ></p> <div style="display: flex; justify-content: space-around;"> <div data-bbox="349 946 836 1287">  <p>① Blue ② Red ③ White ④ Yellow</p> <p>Check the ②, ④</p> </div> <div data-bbox="1015 946 1453 1287">  <p>① Blue ③ White</p> <p>Check the ①, ③</p> </div> </div> <div style="display: flex; justify-content: space-around; margin-top: 10px;"> <div data-bbox="1015 1298 1356 1457">  </div> <div data-bbox="1015 1468 1258 1670">  <p>Check the ①, ③</p> </div> </div> <p>Check to see if there is electrical current, if there is resistance the damper is good.</p>		Housing No. & L/Wire Color	Step				1	2	3	4	1- Blue (A)	+	-	-	+	2- Red (B)	+	+	-	-	3- White(A)	-	+	+	-	4- Yellow(B)	-	-	+	+
Housing No. & L/Wire Color	Step																														
	1	2	3	4																											
1- Blue (A)	+	-	-	+																											
2- Red (B)	+	+	-	-																											
3- White(A)	-	+	+	-																											
4- Yellow(B)	-	-	+	+																											
<p>Standard</p>	<p>Damper</p> <table border="1" style="width: 100%; border-collapse: collapse; text-align: center;"> <thead> <tr> <th>Test Points</th> <th>Result</th> </tr> </thead> <tbody> <tr> <td>Red and Yellow</td> <td>270~330</td> </tr> </tbody> </table>	Test Points	Result	Red and Yellow	270~330	<table border="1" style="width: 100%; border-collapse: collapse; text-align: center;"> <thead> <tr> <th>Test Points</th> <th>Result</th> </tr> </thead> <tbody> <tr> <td>Blue and White</td> <td>270~330</td> </tr> </tbody> </table>	Test Points	Result	Blue and White	270~330																					
Test Points	Result																														
Red and Yellow	270~330																														
Test Points	Result																														
Blue and White	270~330																														

10-9 Flow Sensor

Function	Flow Sensor (in machine room) Count the water quantity from city water to water filter in refrigerator					
How to Measure	<div style="display: flex; justify-content: space-around; align-items: center;">   </div> <p style="text-align: center;">Flow Sensor (in machine room)</p>					
Standard	<table border="1" style="margin-left: auto; margin-right: auto;"> <thead> <tr> <th>Test Points</th> <th>Result</th> </tr> </thead> <tbody> <tr> <td>Red wire to Black wire</td> <td>4 ~ 30 k</td> </tr> </tbody> </table>		Test Points	Result	Red wire to Black wire	4 ~ 30 k
Test Points	Result					
Red wire to Black wire	4 ~ 30 k					

11. Compressor Troubleshooting

PCB Check (Simplify)

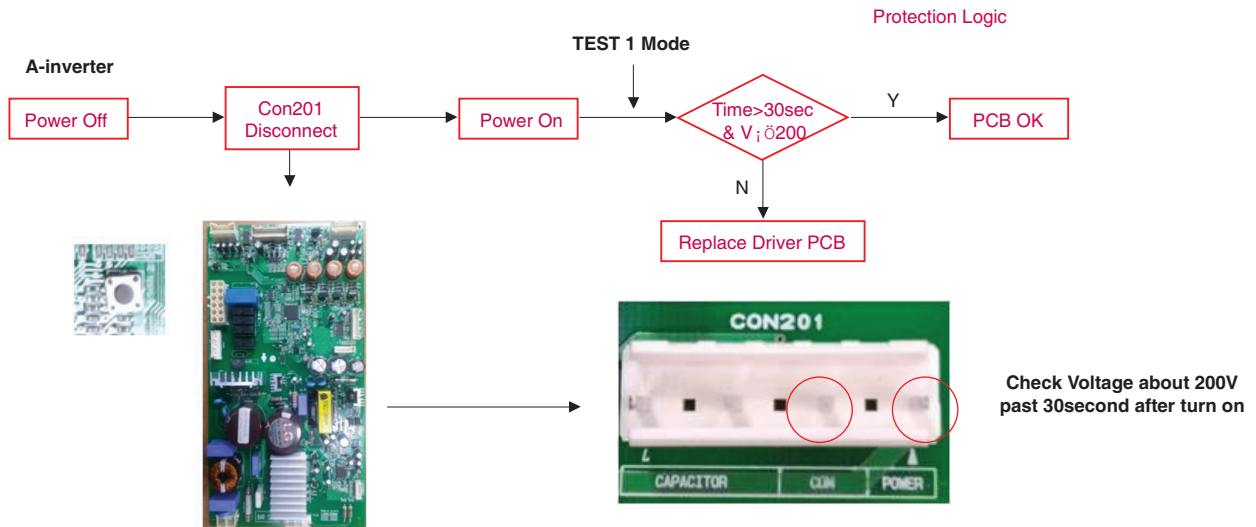

Test Mode

	Ref.	Comp	Display & sound	Refer
		FLB075(A-Inverter)		
TEST1	Forced Starting	TDC (Full Stroke)	Display ON, Buzz 1 time	

Troubleshooting

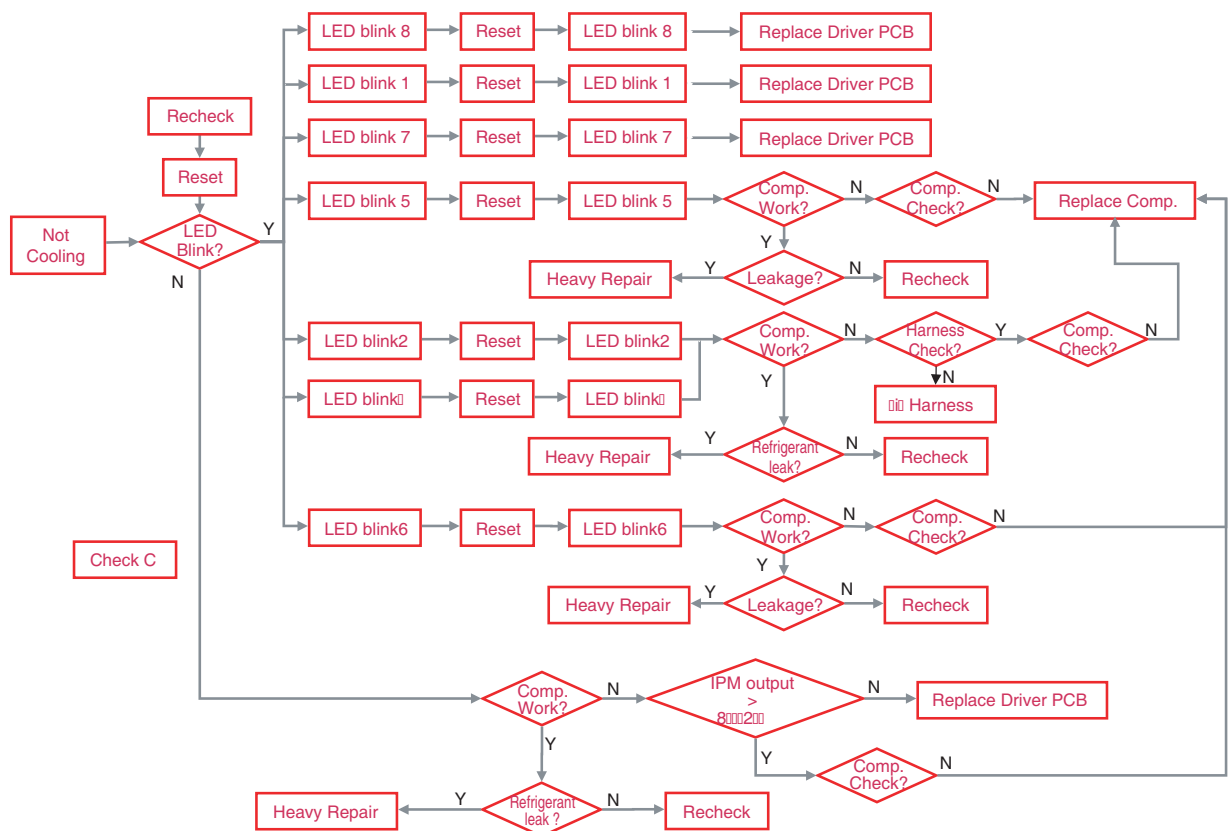

11-1 Check A

- There is PC Board located in the PCB case.
The control driver is PC board for the compressor.
- This step shows the source voltage of the driver PC board.

Step1. Open PCB Cover



Step2. Check Driver PCB



LED Lamp

* Driver PCB located in machine room.

IPM Output check

- Measure the voltage between the POWER and COMM pins of the connector as shown below.

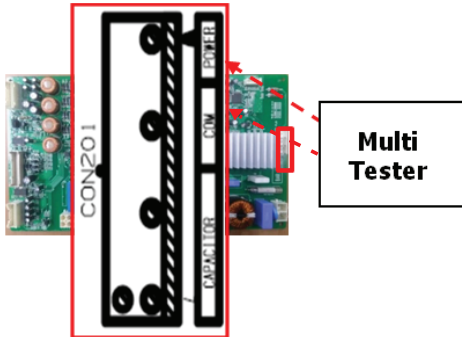

Check to make sure compressor is receiving voltage from IPM

- In order to determine whether the compressor is operating normally, check the output voltage during the refrigeration cycle.
- After initial power-up, when the compressor begins to operate, wait 10 minutes before checking.
- The compressor is operating normally if the voltage is greater than 80V.

11-2 Check B

B1. LED blinks once, then repeats (FCT0 Fault: A-Inverter)

Protection Logic



Blink OFF Blink OFF

- Purpose: Detecting motor current and voltage error
- Check voltage at **point A** (Motor Voltage), **point B** (Motor Current) and **Point C** (Capacitor Voltage) when **compressor is off**.
- Spec: **Points A, B, & C 2.5V 0.3V**

⊙ GND
○ Voltage

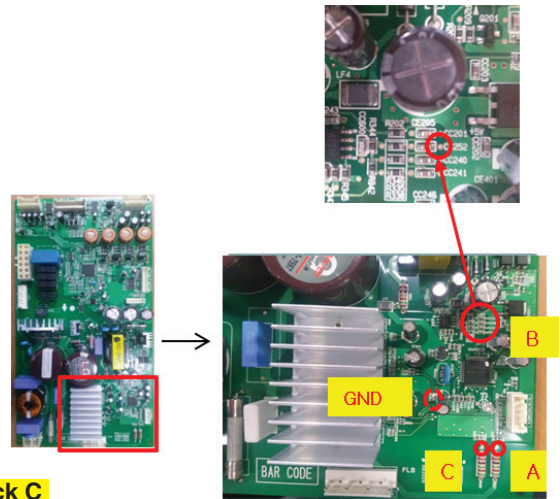
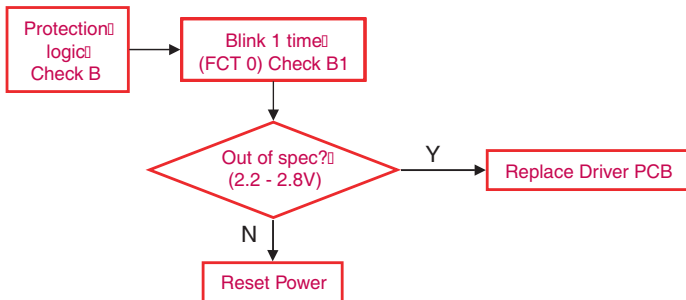

Caution : Devices should not be short-circuited during check C

B2. LED blinks two times, then repeats (Stroke Trip: A & E Inverters)

Protection Logic



Blink Blink OFF Blink Blink OFF

- Purpose: Prevent abnormally long piston strokes.
- Case 1. If compressor doesn't work and LED blinks - Cause: Possibly harness from compressor to PCB might be defective.
- Case 2. If compressor works intermittently and LED blinks - Cause: Condenser Fan or Freezer Fan is not running. Sealed system problem such as moisture restriction, restriction at capillary tube or refrigerant leak.
- Logic: Compressor is forced to off and then tries to restart after 1 minute.

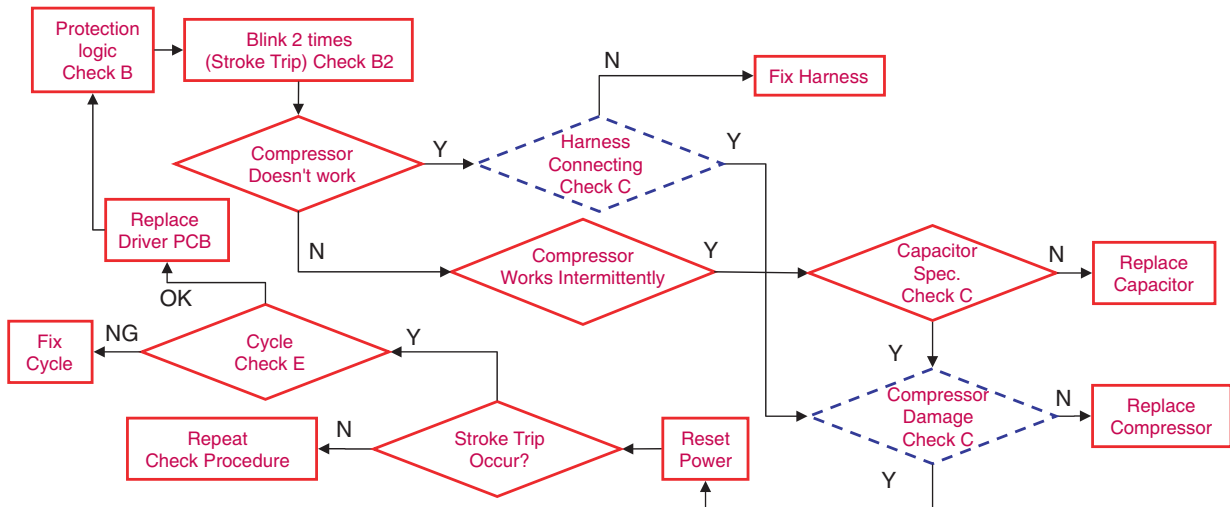

B3. LED blinks three times, then repeats (Stroke Trip)

Protection Logic



Blink Blink Blink OFF Blink Blink Blink OFF

- Purpose : Prevent over voltage and current detecting connecting error.
- Cause : -.Connecting error of PCB and Comp, Capacitor harness -. Comp insulation damage.
- Logic : Compressor is forced off and tries to restart within 40 seconds.

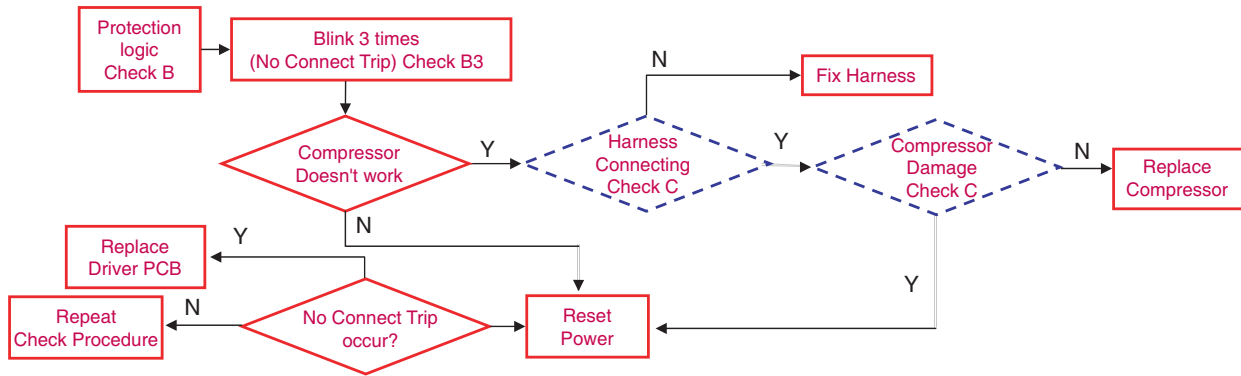

B4. LED blinks five times, then repeats (Locked Piston: A & E Inverters)

Protection Logic



Blink Blink Blink Blink Blink OFF

- Purpose: To detect locked piston
- Cause: Lack of oil to the cylinder, cylinder or piston damaged and or restricted discharge. A Locked Piston can also be caused by foreign materials inside the compressor.
- Logic: Compressor is forced off and tries to restart within 2.5 minutes.

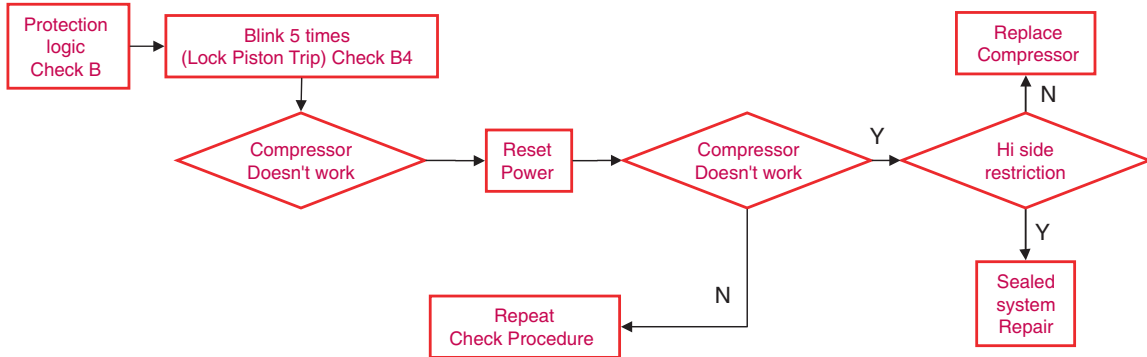

B5. LED blinks six times, then repeats (Current Trip: A & E-Inverters)

Protection Logic



Blink Blink Blink Blink Blink Blink OFF

- Purpose: Prevent over-current (overload protect)
- Cause: Ambient temperature is high (over 43°C) and/or refrigerator's condenser air movement is restricted.
- Condenser Fan is stopped, restricted discharge line, compressor is damaged, or IPM device is defective.
- Logic: Compressor is forced off and tries to restart after 6 minutes.

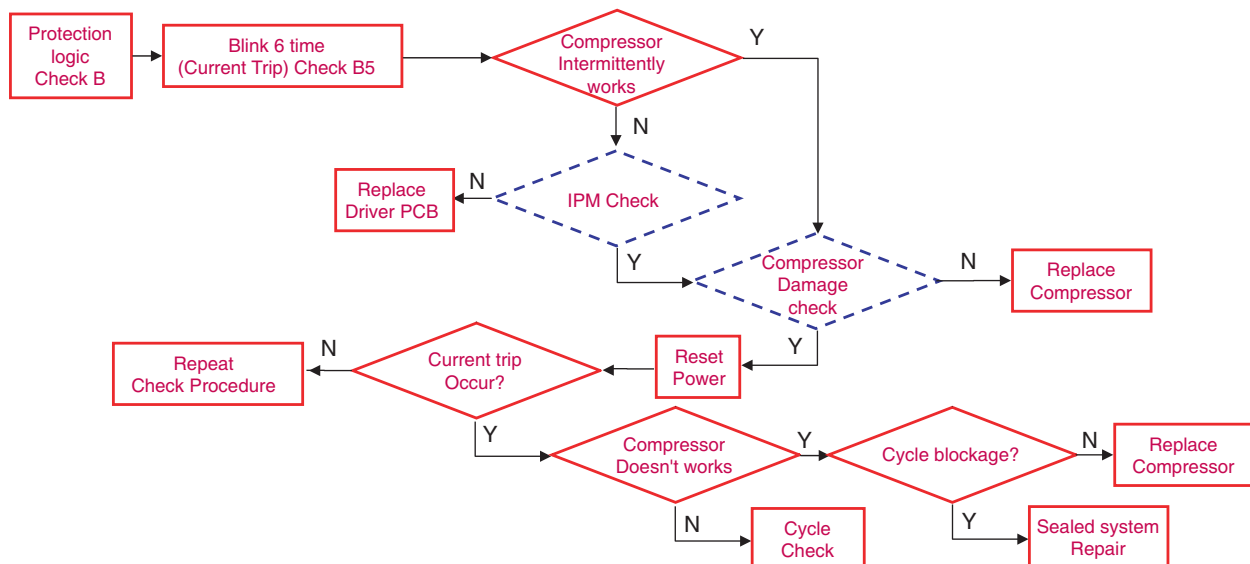

B6. LED blinks seven times, then repeats (IPM Fault: A & E Inverters)



Blink Blink Blink Blink Blink Blink OFF

- Purpose: Prevent high current due to IPM Short
- Cause: Damaged IPM (Dead Short)
- Test for a dead short at **Point A** with a VOM.
- Logic: Compressor is forced off and tries to restart in 20 seconds.

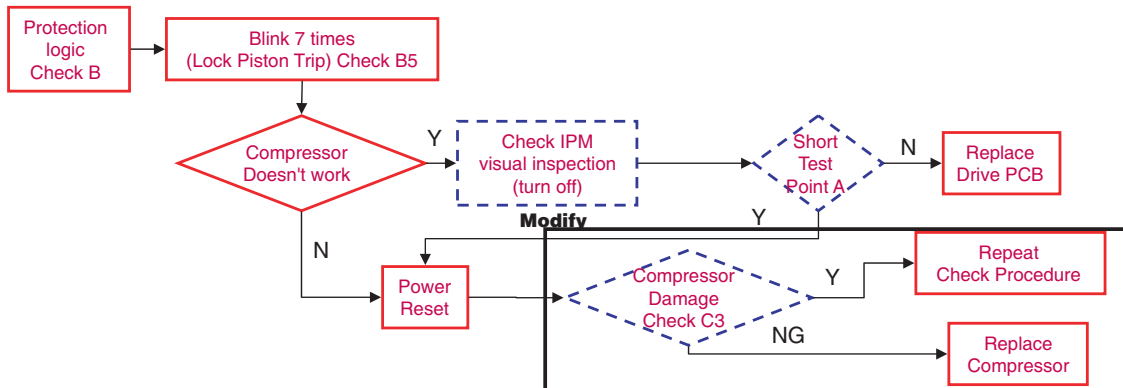
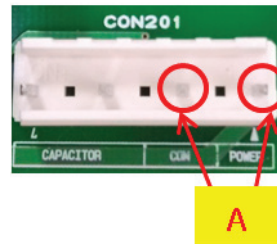
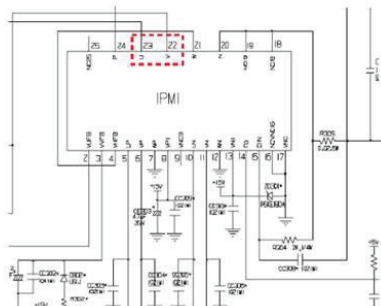

B7. LED Blinks eight times, then repeats (Communication Error)



Blink Blink Blink Blink Blink Blink Blink OFF

- Purpose: To detect Set control Micom and communication error
- Cause : Communication Error
- Logic : LED blink. (Compressor runs reference value before occuring communication Error)

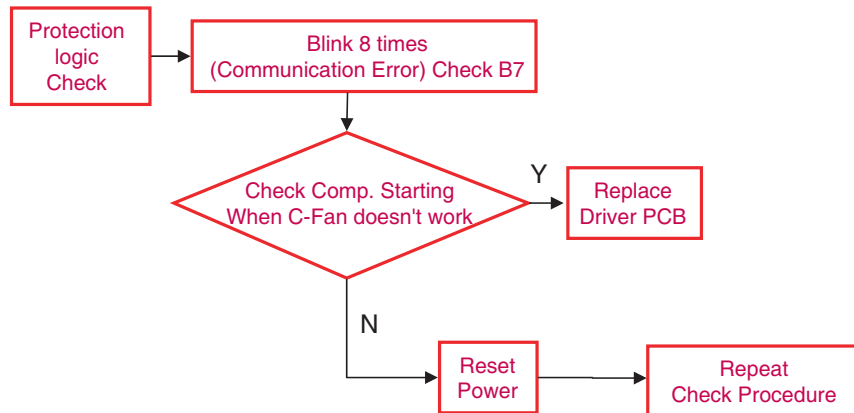
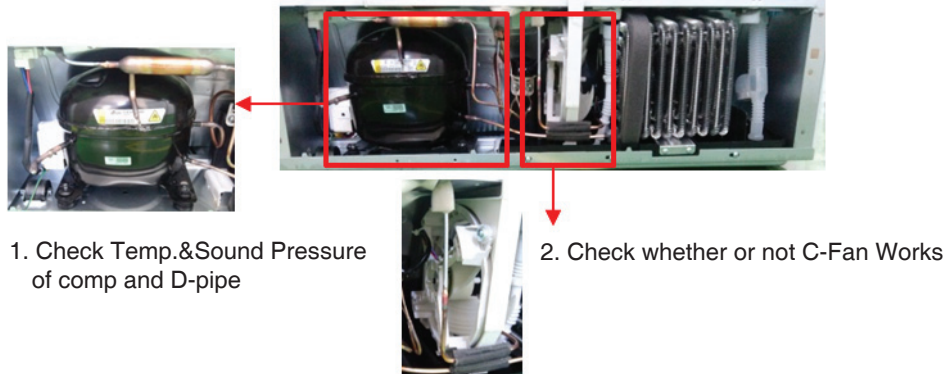

11-3 Check C

- C1. Harness Connection Check
- C2. Capacitor Specifications
- C3. Compressor Check

Check Process

- Step 1. Power off. Step 2. Check capacitor spec. (table1). Step3. Check resistance of point A
- Step 4. Check wire harness (INF ohm). Step 5. Check resistance at point B. Step 6. Point D.

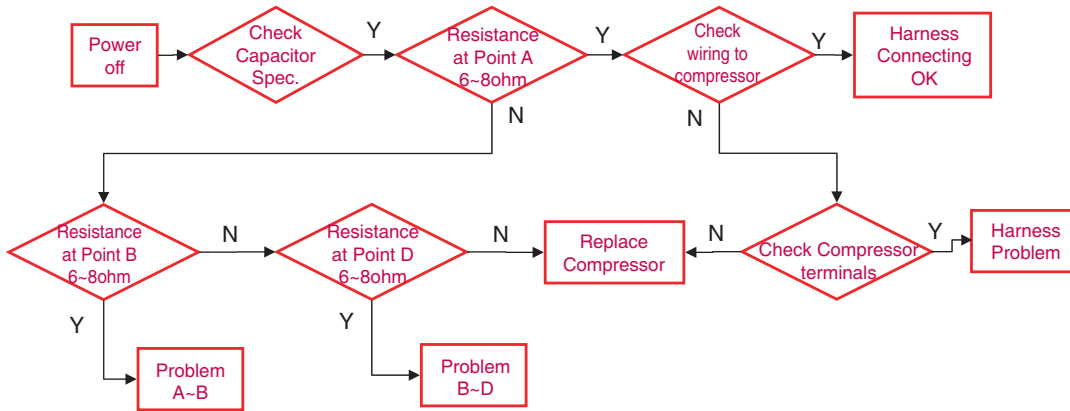

Caution : Turn off power during check C

- Measure the resistance at each point except point C
- Dead short check: measure the resistance between power line in compressor and earth ground in refrigerator (Inf. Ohm)

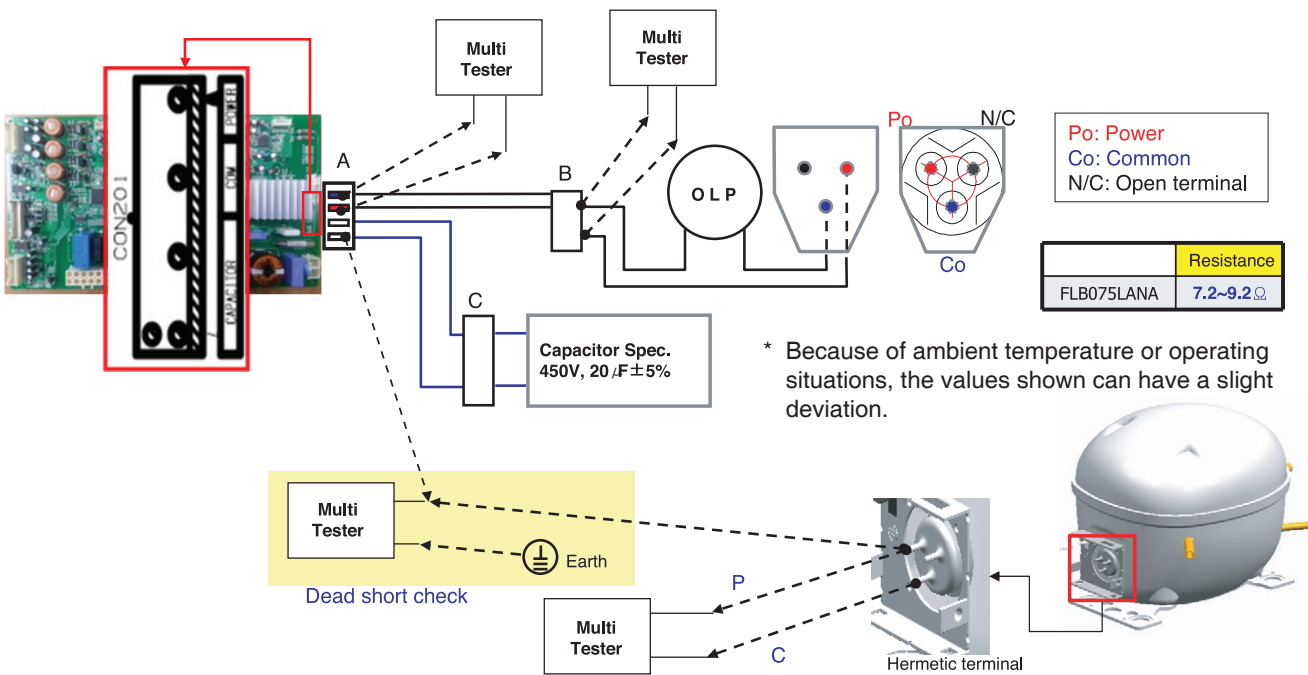

11-4 Check D

D1. Activate Protection logic

Cycle check with protection logic

- We have to check Condenser fan and Freezer fan before performing Check D
- Locked Piston, Current trip and stroke trip can be activated by other problems then the driver or compressor.

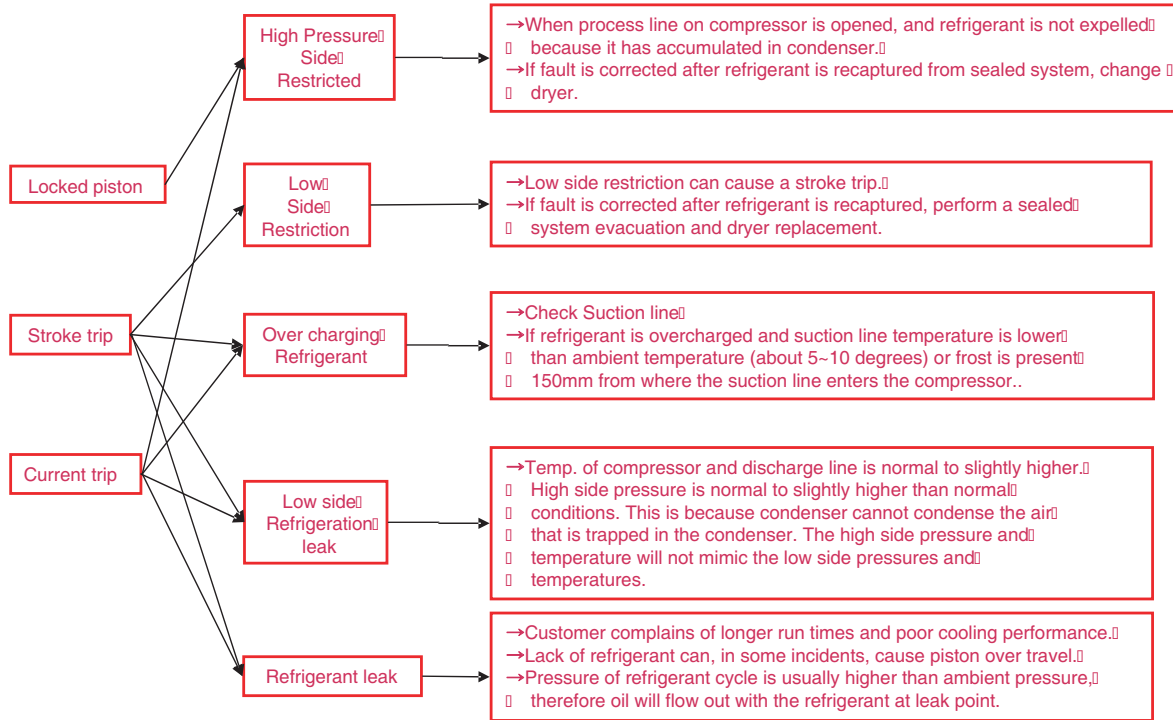

D2. sealed system diagnosis

- Check as follows;

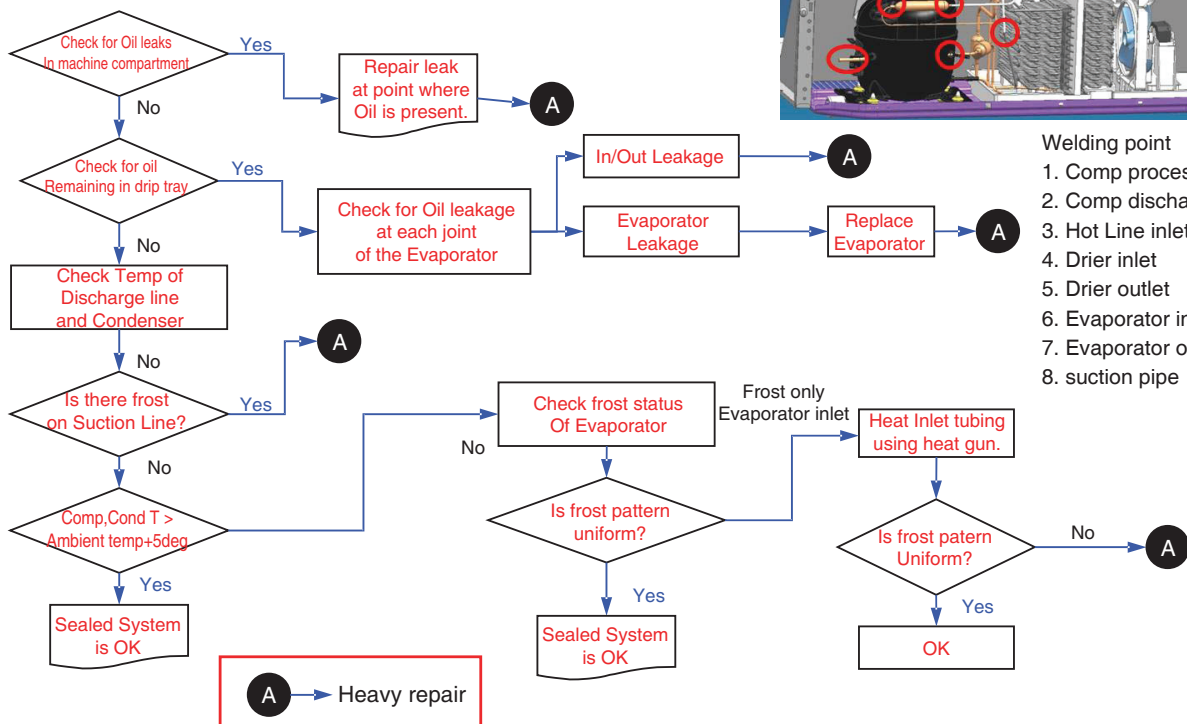

Compressor Troubleshooting

⚠ WARNING HIGH VOLTAGE

Step 1) Open PCB cover



Step 2) Check for blinking frequency of LED and PCB

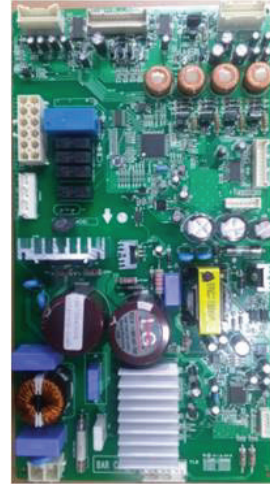

LED Lamp

When compressor is normal, it does not blink
: Refer to the next page to find out what actions to take according to how many times LED blink

11-5 SERVICE DIAGNOSIS CHART

COMPLAINT	POINTS TO BE CHECKED	REMEDY
No Cooling.	<ul style="list-style-type: none"> Is the power cord unplugged from the outlet? Check if the power switch is set to OFF. Check if the fuse of the power switch is shorted. Measure the voltage of the power outlet. 	<ul style="list-style-type: none"> Plug into the outlet. Set the switch to ON. Replace the fuse. If the voltage is low, correct the wiring.
Cools poorly.	<ul style="list-style-type: none"> Check if the unit is placed too close to the wall. Check if the unit is placed too close to the stove, gas cooker, or in direct sunlight. Is the ambient temperature too high or the room door closed? Check if food put in the refrigerator is hot. Did you open the door of the unit too often or check if the door is sealed properly? Check if the Control is set to Warm position. 	<ul style="list-style-type: none"> Place the unit about 4 inches (10 cm) from the wall. Place the unit away from these heat sources. Lower the ambient temperature. Put in foods after they have cooled down. Don't open the door too often and close it firmly. Set the control to Recommended position.
Food in the Refrigerator is frozen.	<ul style="list-style-type: none"> Is food placed in the cooling air outlet? Check if the control is set to colder position. Is the ambient temperature below 41°F(5°C)? 	<ul style="list-style-type: none"> Place foods in the high-temperature section. (front part) Set the control to Recommended position. Set the control to Warm position.
Condensation or ice forms inside the unit.	<ul style="list-style-type: none"> Is liquid food sealed? Check if food put in the refrigerator is hot. Did you open the door of the unit too often or check if the door is sealed properly? 	<ul style="list-style-type: none"> Seal liquid foods with wrap. Put in foods after they have cooled down. Don't open the door too often and close it firmly.
Condensation forms in the Exterior Case.	<ul style="list-style-type: none"> Check if the ambient temperature and humidity of the surrounding air are high. Is there a gap in the door gasket? 	<ul style="list-style-type: none"> Wipe moisture with a dry cloth. It will disappear in low temperature and humidity. Fill up the gap.
There is abnormal noise.	<ul style="list-style-type: none"> Is the unit positioned in a firm and even place? Are any unnecessary objects placed in the back side of the unit? Check if the Drip Tray is not firmly fixed. Check if the cover of the compressor enclosure in the lower front side is taken out. 	<ul style="list-style-type: none"> Adjust the Leveling Screw, and position the refrigerator in a firm place. Remove the objects. Fix the Drip Tray firmly in the original position. Place the cover in its original position.
Door does not close well.	<ul style="list-style-type: none"> Check if the door gasket is dirty with an item like juice. Is the refrigerator level? Is there too much food in the refrigerator? 	<ul style="list-style-type: none"> Clean the door gasket. Position in a firm place and level the Leveling Screw. Make sure food stored in shelves does not prevent the door from closing.
Ice and foods smell unpleasant.	<ul style="list-style-type: none"> Check if the inside of the unit is dirty. Are foods with a strong odor unwrapped? The unit smells of plastic. 	<ul style="list-style-type: none"> Clean the inside of the unit. Wrap foods that have a strong odor. New products smell of plastic, but this will go away after 1-2 weeks.

Other possible problems:

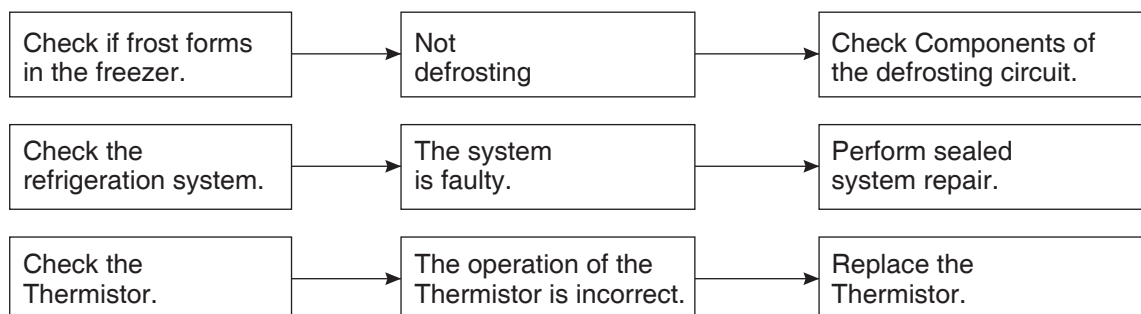

11-6 REFRIGERATION CYCLE

Troubleshooting Chart

CAUSE		STATE OF THE UNIT	STATE OF THE EVAPORATOR	TEMPERATURE OF THE COMPRESSOR	REMARKS
LEAKAGE	PARTIAL LEAKAGE	Freezer compartment and Refrigerator don't cool normally.	Low flowing sound of Refrigerant is heard and frost forms in inlet only.	A little higher than ambient temperature.	<ul style="list-style-type: none"> Refrigerant level is low due to a leak. Normal cooling is possible by restoring the normal amount of refrigerant and repairing the leak.
	COMPLETE LEAKAGE	Freezer compartment and Refrigerator don't cool normally.	Flowing sound of refrigerant is not heard and frost isn't formed.	Equal to ambient temperature.	<ul style="list-style-type: none"> No discharging of Refrigerant. Normal cooling is possible by restoring the normal amount of refrigerant and repairing the leak.
CLOGGED BY DUST	PARTIAL CLOG	Freezer compartment and Refrigerator don't cool normally.	Flowing sound of refrigerant is heard and frost forms in inlet only.	A little higher than ambient temperature.	<ul style="list-style-type: none"> Normal discharging of the refrigerant. The capillary tube is faulty.
	WHOLE CLOG	Freezer compartment and Refrigerator don't cool.	Flowing sound of refrigerant is not heard and frost isn't formed.	Equal to ambient temperature.	<ul style="list-style-type: none"> Normal discharging of the Refrigerant.
MOISTURE CLOG		Cooling operation stops periodically.	Flowing sound of refrigerant is not heard and frost melts.	Lower than ambient temperature.	<ul style="list-style-type: none"> Cooling operation restarts when heating the inlet of the capillary tube.
DEFECTIVE COMPRESSION	COMP-RESSION	Freezer and Refrigerator don't cool.	Low flowing sound of refrigerant is heard and frost forms in inlet only.	A little higher than ambient temperature.	<ul style="list-style-type: none"> Low pressure at high side of compressor due to low refrigerant level.
	NO COMP-RESSION	No compressing operation.	Flowing sound of refrigerant is not heard and there is no frost.	Equal to ambient temperature.	<ul style="list-style-type: none"> No pressure in the high pressure part of the compressor.

11-6-1 Cleaning

There is no need for routine condenser cleaning in normal Home operating environments. If the environment is particularly greasy or dusty, or there is significant pet traffic in the home, the condenser should be cleaned every 2 to 3 months to ensure maximum efficiency.

If you need to clean the condenser:

Remove the mechanical cover.

Use a vacuum cleaner with a soft brush to clean the grille, the open areas behind the grille and the front surface area of the condenser.

Replace the mechanical cover.

11-6-2 SEALED SYSTEM DIAGNOSIS

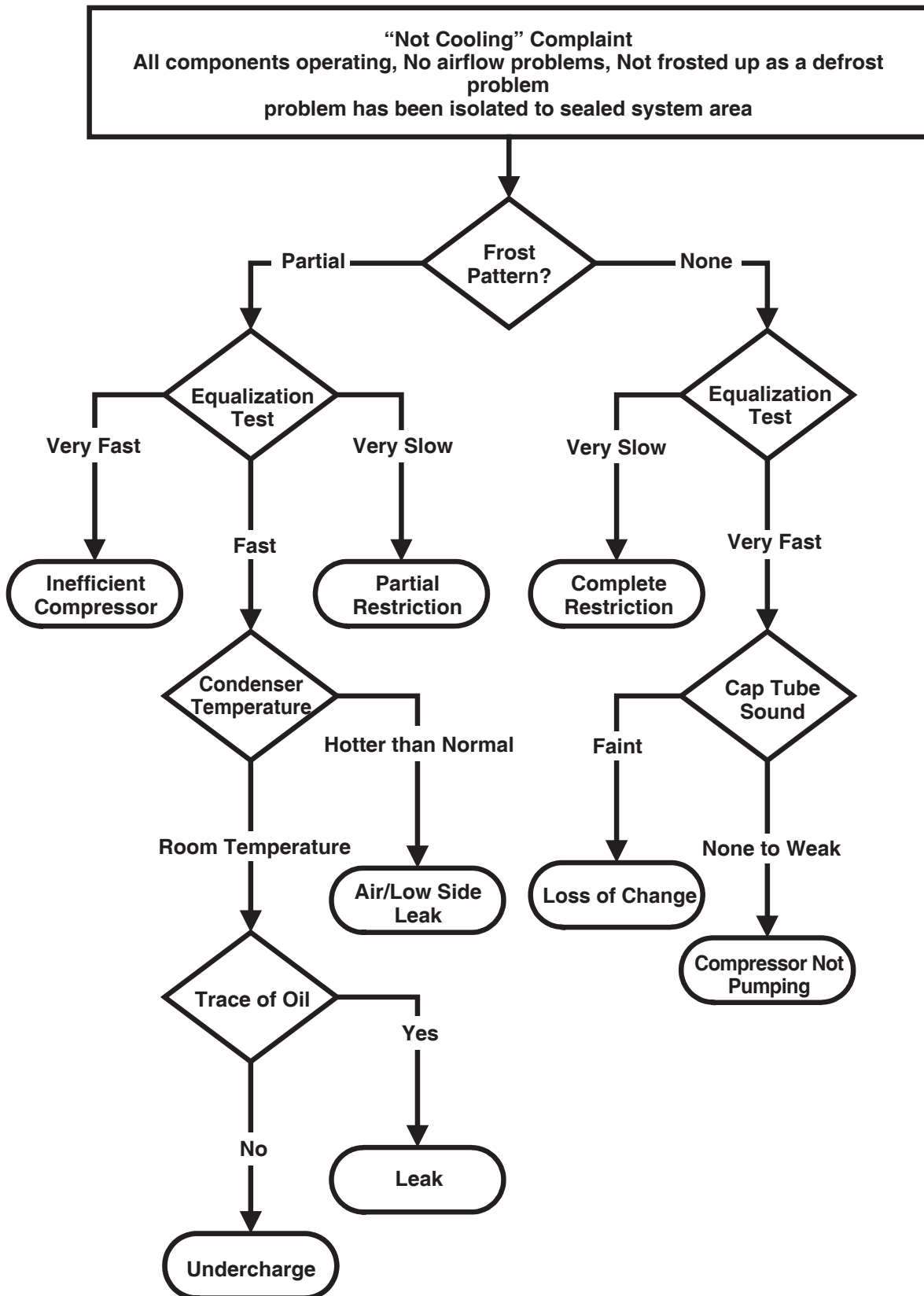

(The equalization test is trying to restart a compressor using a start kit after it has been operating.)

12. ICEMAKER OPERATING METHOD AND TROUBLE SHOOTING

12-1 Icemaker's Basic Operating Method

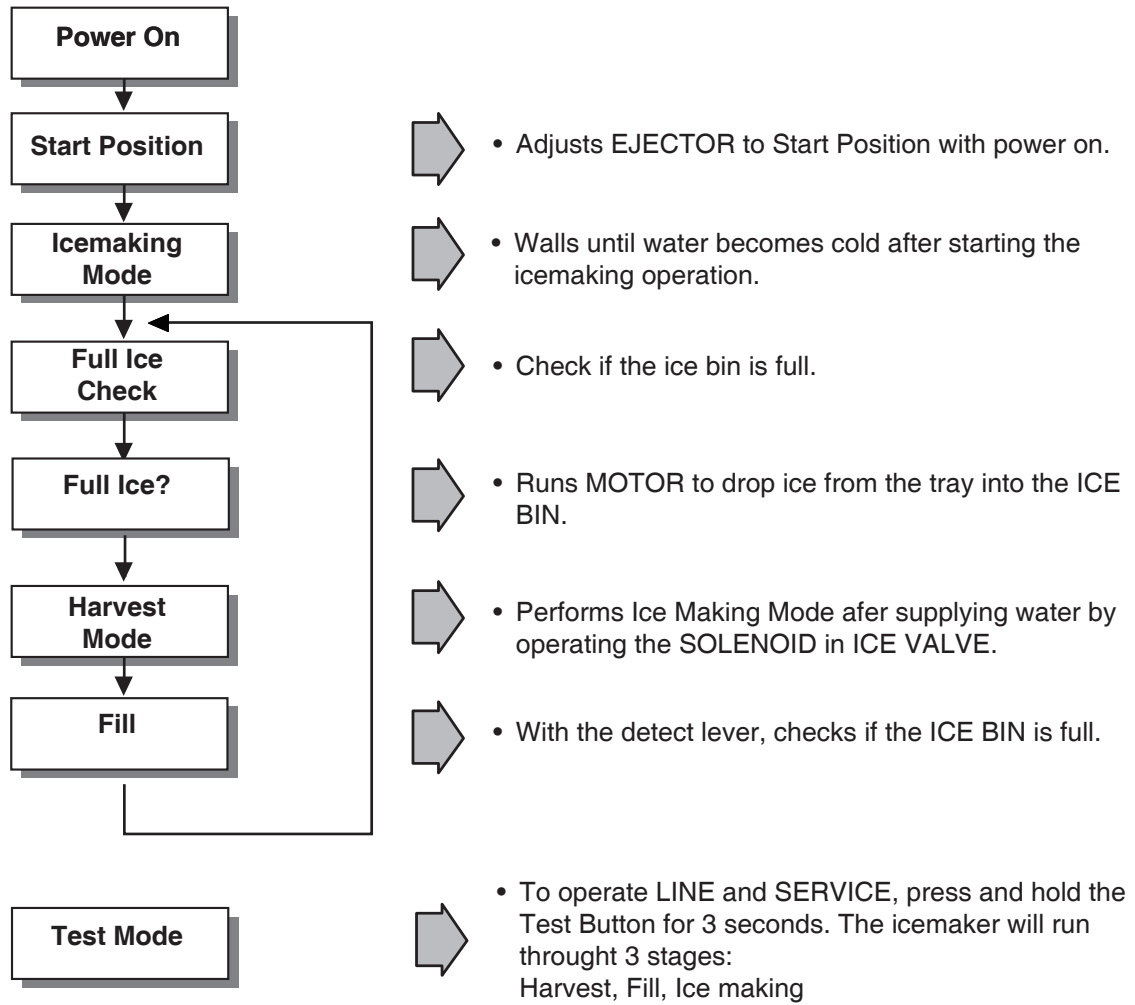

While ICE OFF indicator is on, icemaker stops making ice. But you can dispense the ices until the ices run out from the ice store.

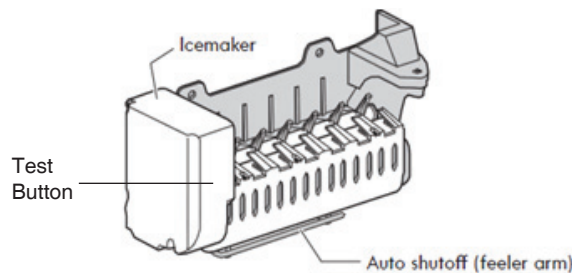

12-2 Trouble Shooting Ice & Water system Issues

12-3 Icemaker not making ice or not making enough ice (Environmental Diagnosis)

Icemaker can't make ices itself. Basically, water, temperature and time are needed.

- Water : If no Water, then no Ice.
- Temperature : The compartment, where the icemaker is located, has to be at least 1°F so that icemaker dumps ices to the bin.
- Time : At least 35 minutes must be passed to make one series of ices after water comes into icemaker.

Test Mode should not be carried out before checking below.

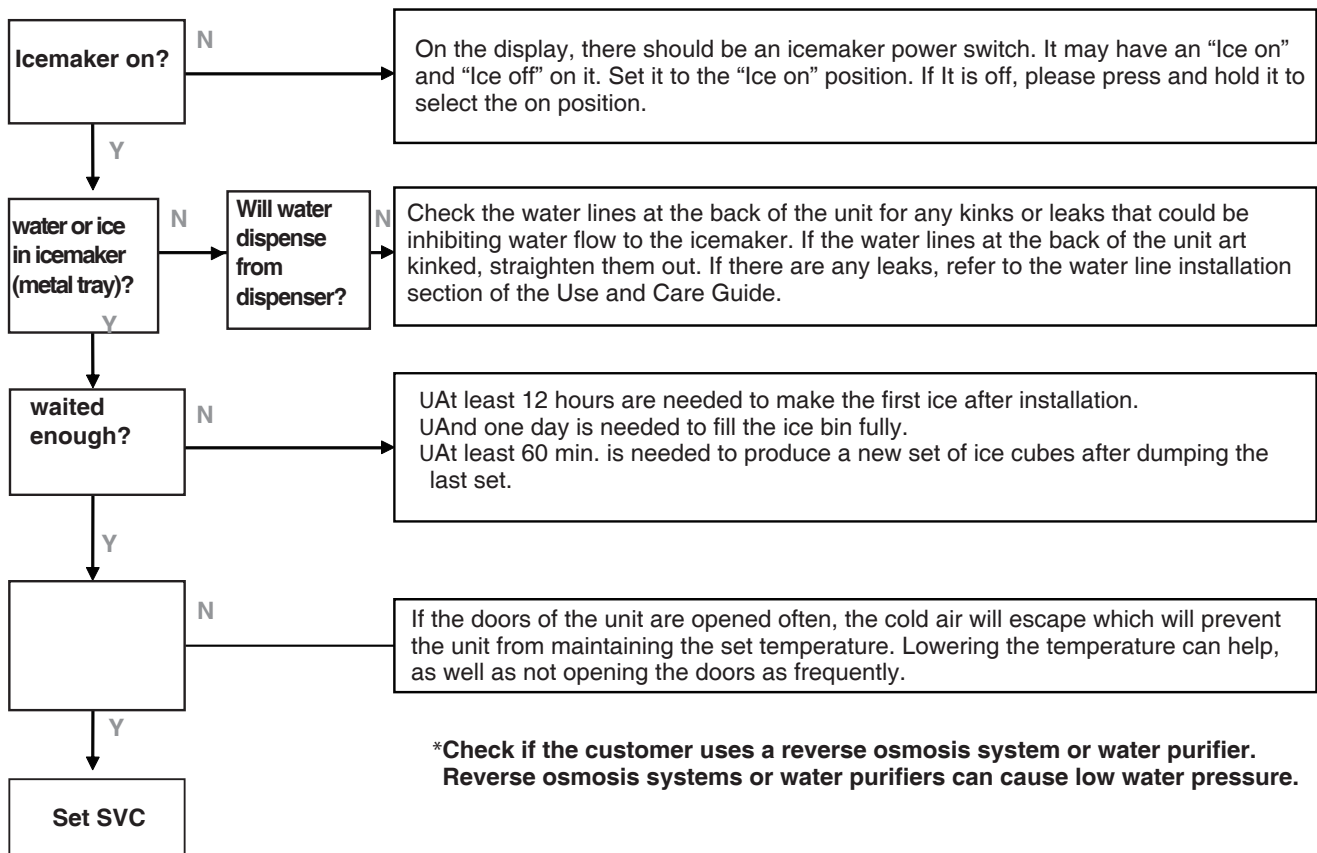

13. DESCRIPTION OF FUNCTION & CIRCUIT OF MICOM

13-1 FUNCTION

13-1-1 Function

1. When the appliance is plugged in, it is set to 37° F for Refrigerator and 0°F for freezer.
You can adjust the Refrigerator and the Freezer control temperature by pressing the ADJUST button.
2. When the power is initially applied or restored after a power failure, it is set to Control temperature Previously.
3. If you do not press any button after turning on the power, only CRUSH or CUBE Label that has been selected will be turned on and all other LEDs on the display Panel will be turned off within 60 seconds. (Power Save Mode)
4. If you press a button, only CRUSH, CUBE label and Lock icon that has been selected will be turned on and all other LEDs on the display Panel will be turned off within 20 seconds. (Power Save Mode)

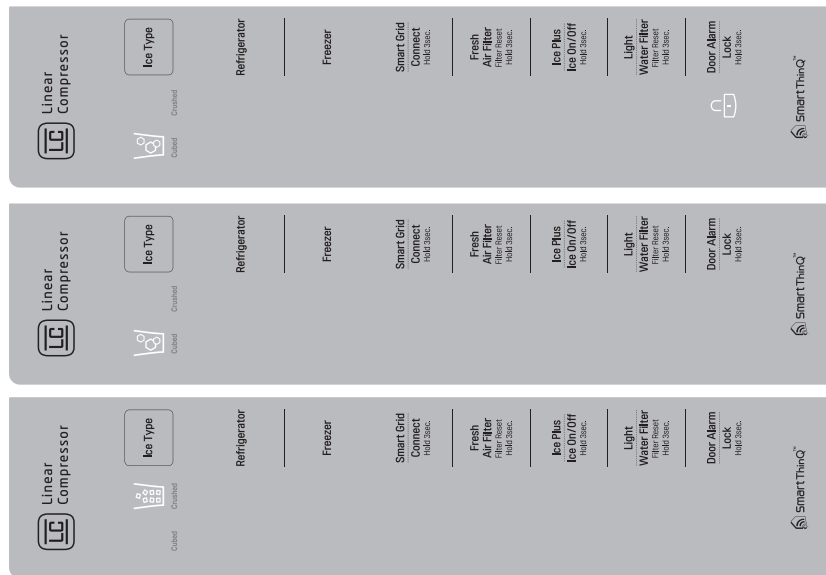

13-1-2 How to Toggle the Display between °F & °C

1. The initial setting is °F and the display temperature mode can be changed from °F to °C or °C to °F by pressing and holding the FRZ TEMP and the REF TEMP keys at the same time for over 5 seconds.

13-1-3 Lock function (dispenser and display button Lock)

1. When the refrigerator is first turned on, the buttons are not locked. "LOCK" is deactivated with "Unlock Icon" on.
2. To lock the display, the dispenser, and the control panel, press and hold the LOCK button for 3 seconds. "LOCK" is activated with "Lock Icon" on.
3. The LOCK button is the only control feature that remains active in the locked state. The buzzer sound, other control buttons, and the dispenser are deactivated.
4. To release from the locked state, press and hold the LOCK button again for 3 seconds.
5. If you don't hold the Alarm/Lock button more than 3 seconds, Alarm function will be changed and alarm for opened door will be on/off same as alarm icon indicating.



Ex) In selecting "LOCK"

Ex) In selecting "LOCK" again

13-1-4 Filter condition display function

1. There is a replacement indicator light for the filter cartridge on the dispenser.
2. Water filter needs replacement once six months or of using water filter.
3. When the Water Filter Icon blinks, you must exchange the filter.
4. After replacing the filter, press and hold the Light/Filter button for more than 3 seconds.
After then water Filter icon turn off with reset status.

Classification	In initial Power On / Filter RESET	Blinking
Filter Status Display		

13-1-5 Air Filter condition display function

1. There is a replacement indicator light for the Air Filter cartridge.
2. Air filter needs replacement once every 6 months.
3. When the charger Icon blinks, you must exchange the filter.
4. After replacing the filter, press and hold Air filter button for more than 3 seconds.
After then Air filter icon turn off with reset status.

Classification	In initial Power On / Filter RESET	Blinking
Filter Status Display		

13-1-6 Air Filter selection

Please select this function for Air Filter.

1. When you press the Air Filter Button, the POWER will be turned on again.
2. Air Filter POWER function automatically turns off after a fixed time passes.



13-1-7 Ice Plus selection

1. Please select ice plus function for quick freezing.
2. When you press the ice plus button, the ice plus icon will be turned on again.
3. Ice plus function automatically turns off after a fixed time passes.



13-1-8 Dispenser use selection

You can select water or ice by separated pad switch.

1. When you press ice type button, ice type will be changed. (Crush or Cube)
2. Hold your cup in the dispenser for a few seconds after dispensing ice or water to allow the last pieces of ice drops of water to fall into the cup.
3. When after initially establishing the water comes out, the water tank inside fills and until at the time of quality the hour is caught.



13-1-9 Connect of Wireless Network

1. In order to use function of Smart Grid, must be connected to the wireless network.
2. When you press the Smart Grid/Connect Button for 3 seconds, start to blink of WiFi Icon for 3 minutes.
3. Product register is complete, WiFi Icon and Grid Icon will be turned on.
4. When WiFi Icon is blinking, press the Smart Grid/Connect Button for 3 seconds or fail of product register, WiFi Icon is stop blinks and turns off.

13-1-10 CONTROL OF FREEZER FAN MOTOR

1. Freezer fan motor has high and standar speed.
2. When refrigerator is overloaded, fan motor runs in high speed as powered-up Standard speeds is used for general purposes.
3. To improve cooling speed, the RPM of freezer fan motor changes from normal speed to high.

13-1-11 Cooling Fan Motor

1. The cooling fan is switched ON and OFF in conjunction with the compressor.
2. The Failure sensing method is the same as in the fan motor of the freezing fan motor(refer to failure diagnosis function table for failure display).

13-1-12 Ice Compartment Fan

1. The Icing Fan is controlled by the the sensor on the top of the ice compartment.
2. The Failure sensing method is the same as in the fan motor of the freezer (refer to failure diagnosis function table for failure display)

13-1-13 Refrigeration room Fan Motor

1. The refrigeration room fan is switched ON and OFF in conjunction with the refrigeration room temperature.
2. The Failure sensing method is the same as in the fan motor of the freezing fan motor (refer to failure diagnosis function table for failure display).

13-1-14 Ice PLUS

1. The purpose of this function is to intensify the cooling speed of freezer and to increase the amount of ice.
2. Whenever selection switch is pressed, selection/release, the Icon will turn ON or OFF.
3. If there is a power outage and the refrigerator is powered on again, Ice PLUS will be canceled.
4. To activate this function, press the Ice PLUS key and the Icon will turn ON. This function will remain activated for 24 hrs.
 - (1) control temperature of freezer room is to set -2 F notch temperture.
 - (2) If ice bin is full of ice, no change logic of ice compartment fan.
 - (3) If function is activitied and de-ice status to be, ice compartment fan is operated by force.
 - Upper RT 18 C, Standard RPM
 - Below RT 18 C, operate low speed RPM

13-1-15 How to set the display mode and cancel it

1. With the refrigerator door open, keep pressing the Refrigerator Temp Button and ICE PLUS Button more than 5 seconds, then it goes to the display mode with Special Beep Sound With Special Beep Sound.
2. Perform the same way again to cancel the display mode.
3. All Freezing unit will be turned off at display mode (Exceptions : Lamp, Display)

13-1-16 Defrosting (removing frost)

1. Defrosting starts each time the COMPRESSOR running time Between 7~50 hours.
2. Defrosting stops if the sensor temperature reaches 41°F(5°C) or more. If the sensor doesn't reach 41°F(5°C) in 1 hours, the defrost mode is malfunctioning. (Refer to the defect diagnosis function)
3. Defrosting won't function if its sensor is defective (wires are cut or short circuited)

13-1-17 Defect Diagnosis Function

1. Automatic diagnosis makes servicing the refrigerator easy.
2. When a defect occurs, the buttons will not operate.
3. When the defect CODE removes the sign, it returns to normal operation (RESET).
4. The defect CODE shows on the Refrigerator and Freezer Display.

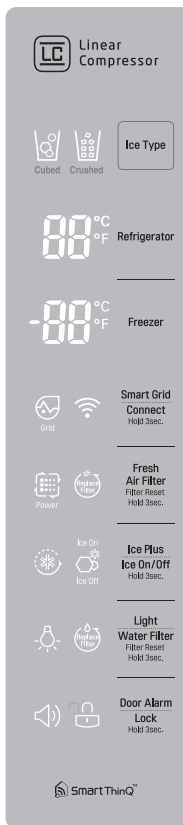

- * Display check function: If simultaneously pressing Ice Plus button and freezing temperature adjustment button for a second, display LCD graphics on. If releasing the button, the LCD graphic displays the previous status.
You can check the error code Within 3-hour Period from initial error

13-1-18 Auto pantry

1. The temperature control will automatically start upon the selected Auto Pantry temperature control.
2. You can adjust the Pantry control with three different temperature ranges by pressing the Temp.Selector button.

14. EXPLODED VIEW & REPLACEMENT PARTS LIST

CASE PARTS

CAUTION : Use the part number to order part, not the position number.

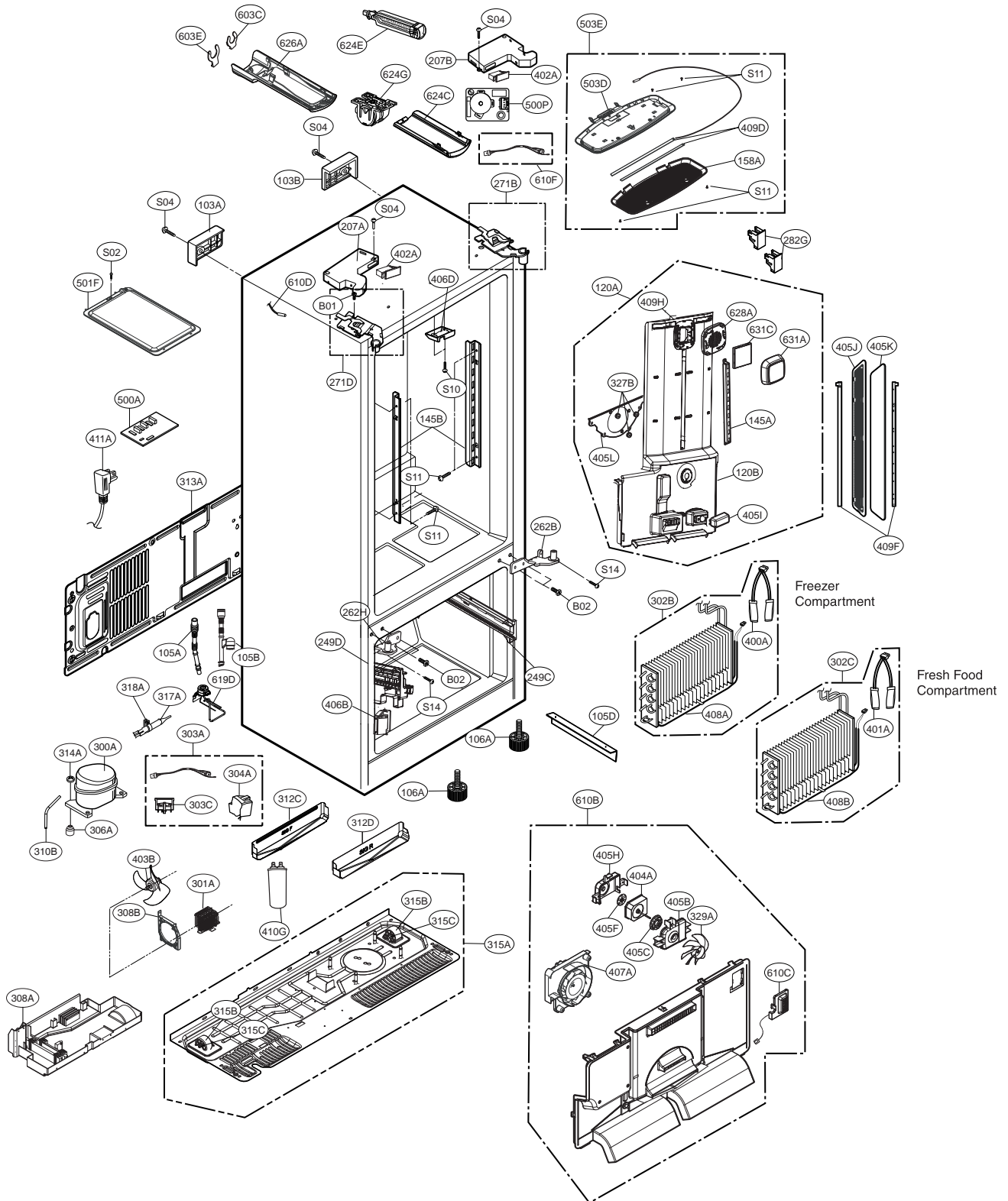

FREEZER PARTS

CAUTION: Use the part number to order part, not the position number.

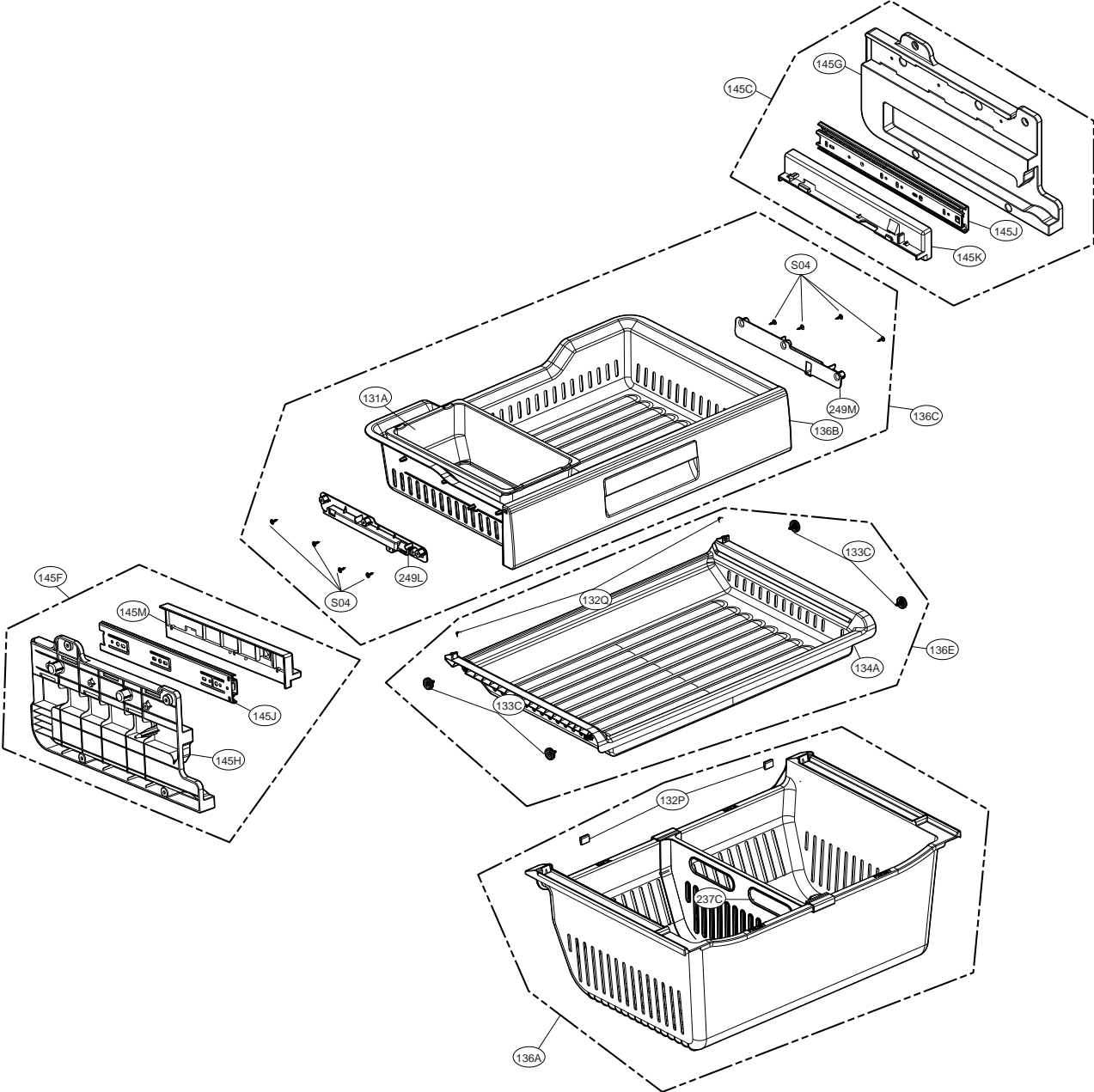

REFRIGERATOR PARTS

CAUTION: Use the part number to order part, not the position number.

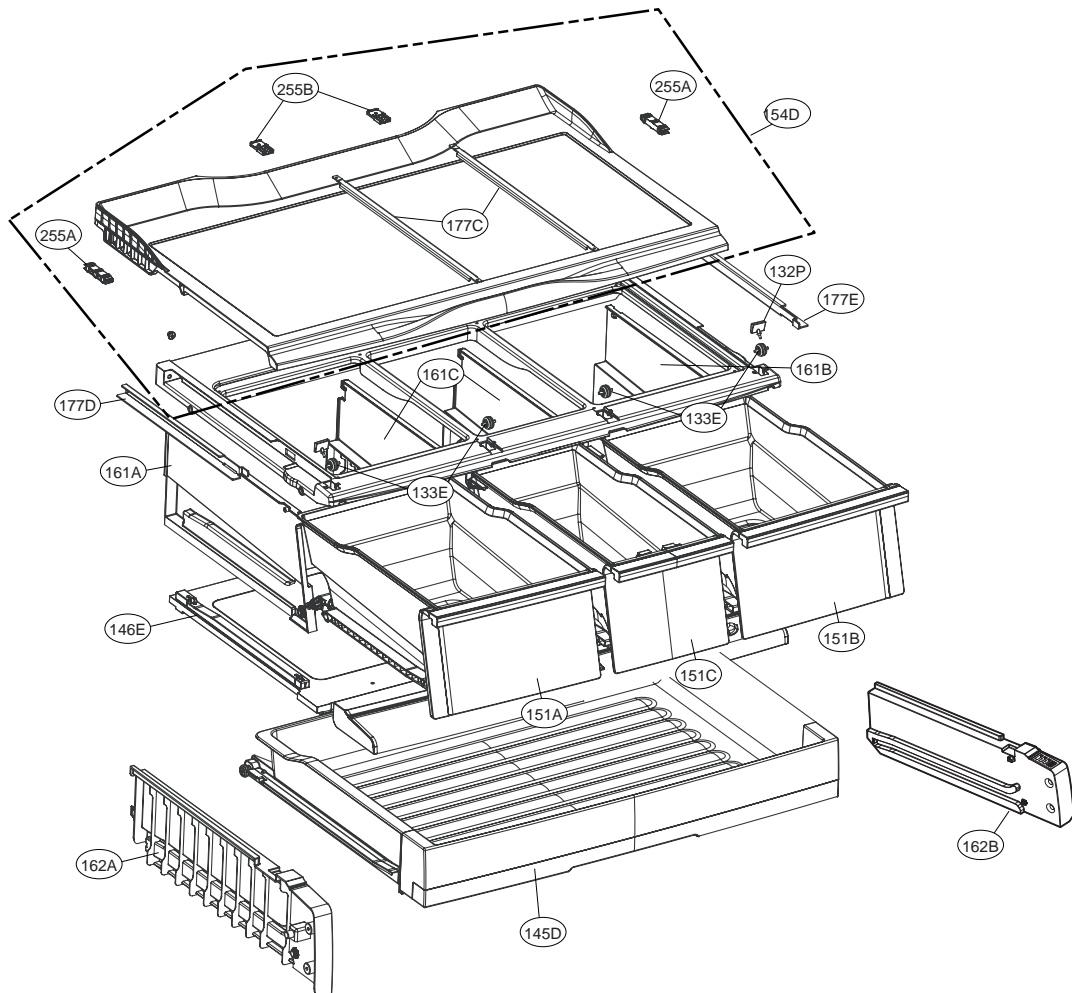
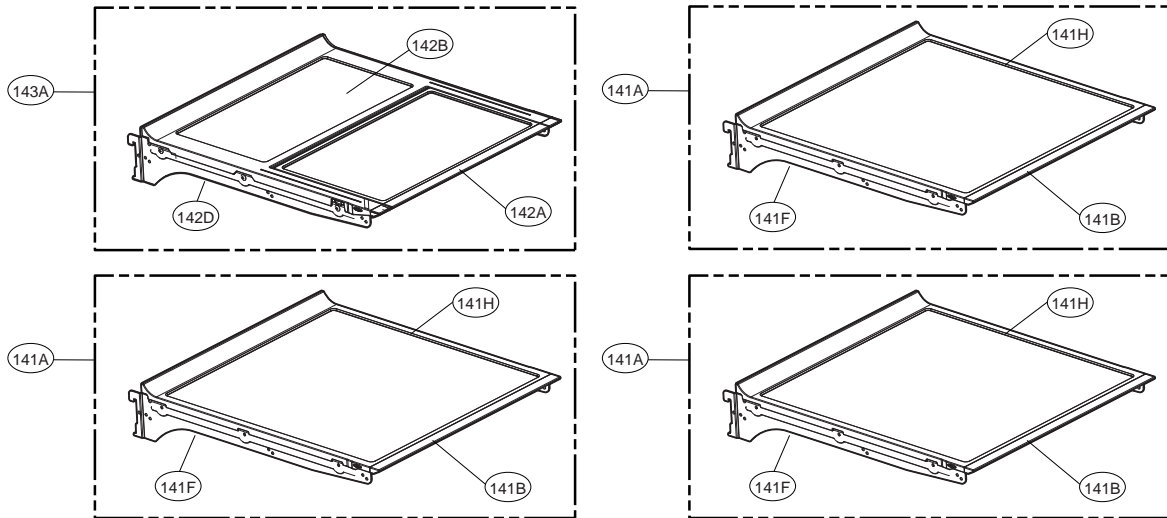

DOOR PARTS

CAUTION: Use the part number to order part, not the position number.

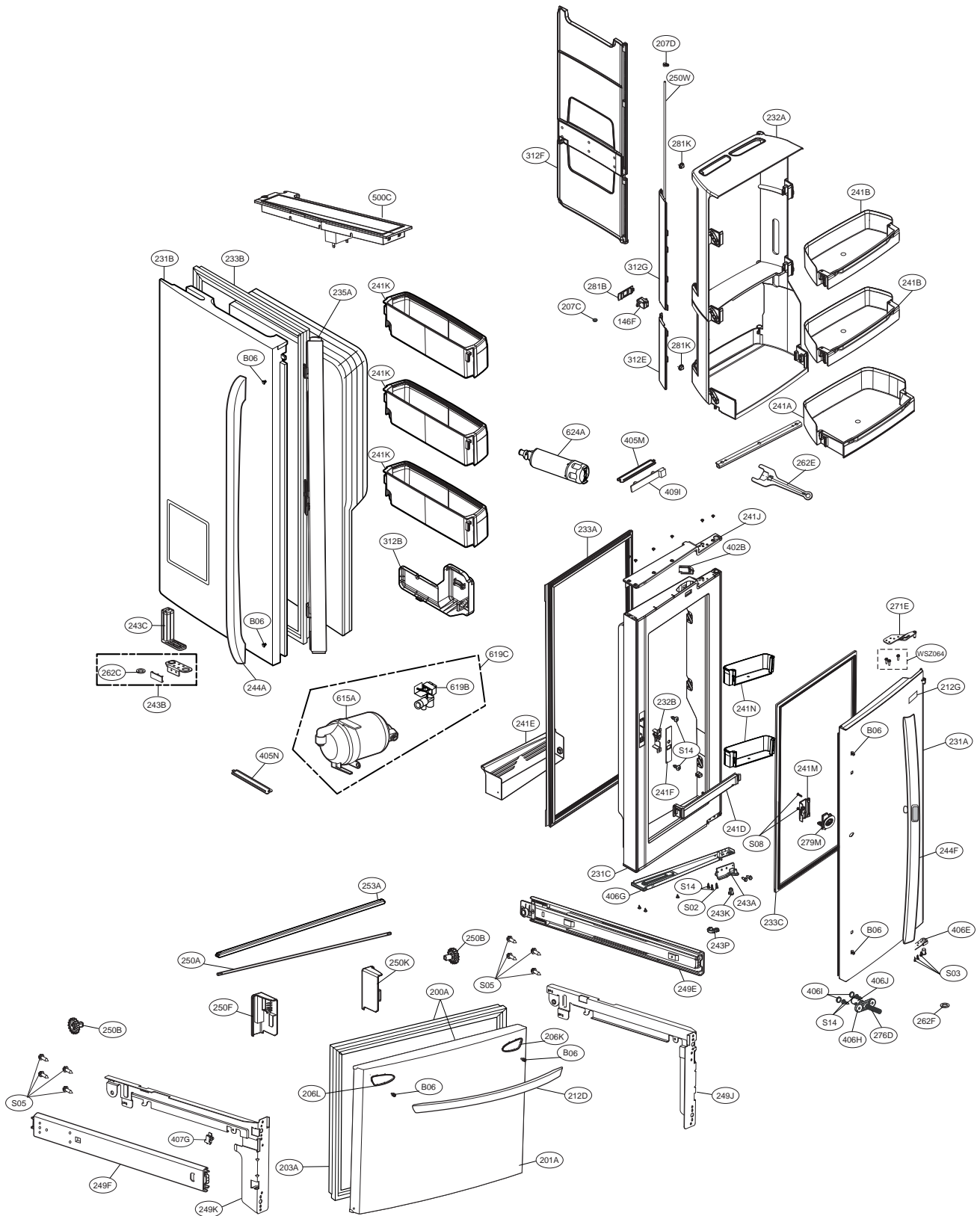

DISPENSER PARTS

CAUTION: Use the part number to order part, not the position number.

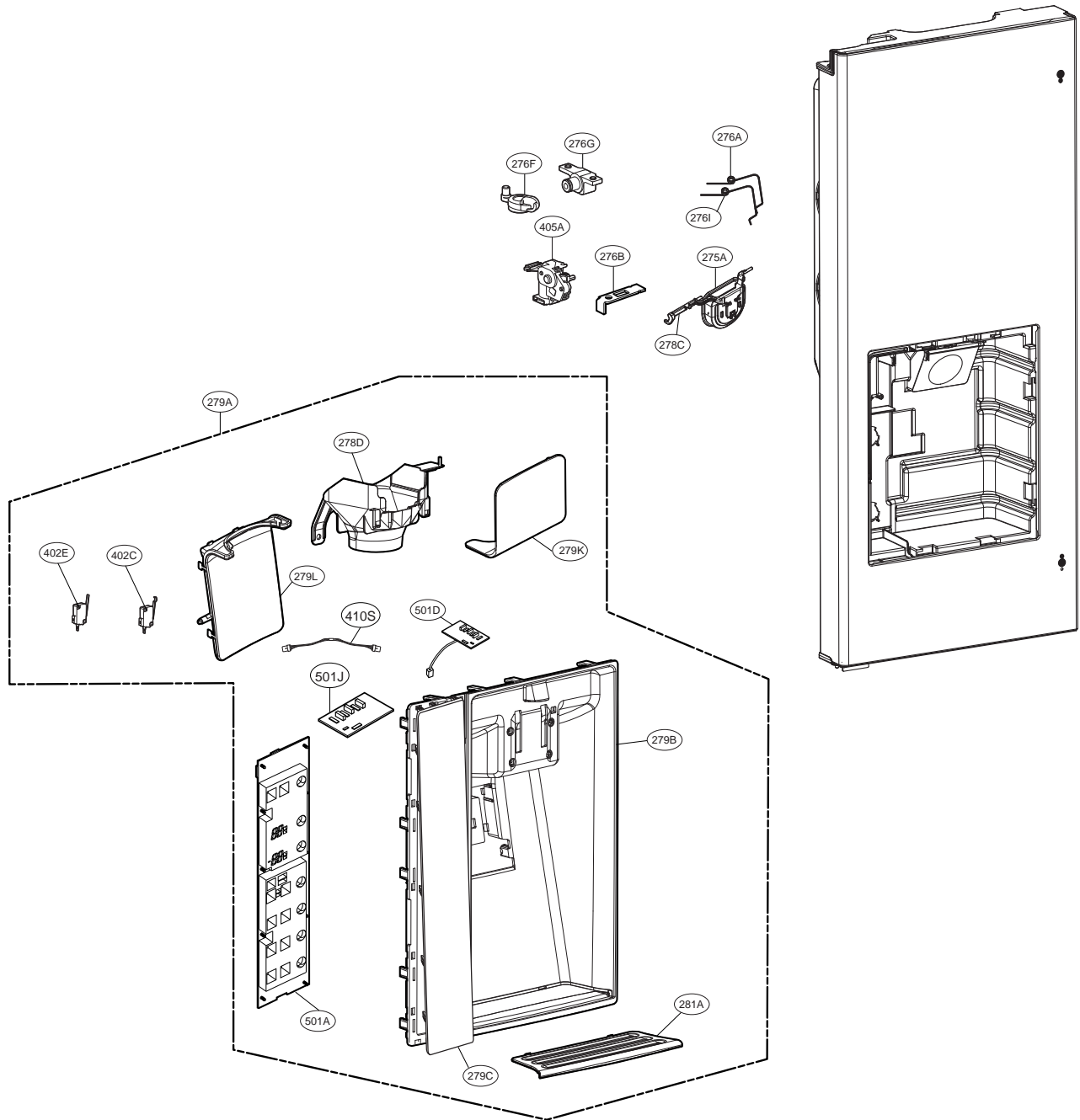

VALVE & WATER TUBE PARTS

CAUTION: Use the part number to order part, not the position number.

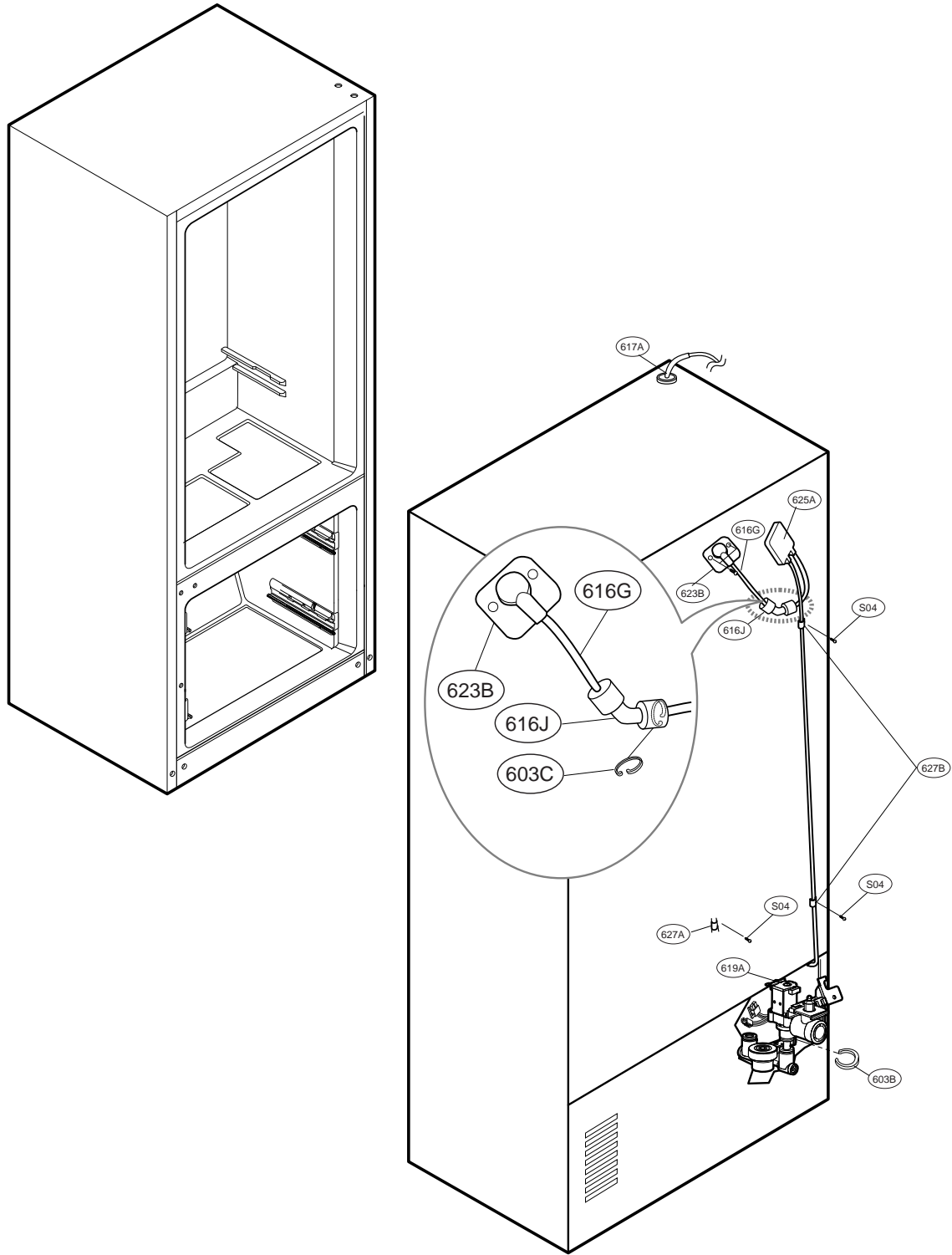

ICE MAKER & ICE BIN PARTS

CAUTION: Use the part number to order part, not the position number.

