



TECHNICAL EDUCATION
Direct Drive FL Washer



WFW94HEX
WFW95HEX

FORWARD

This Whirlpool Job Aid, "Direct Drive FL Washer" (Part No. W10372167), provides the In-Home Service Professional with information on the installation, operation, and service of the "Direct Drive FL Washer". For specific information on the model being serviced, refer to the "Use and Care Guide," or "Tech Sheet" provided with the washer.

The Wiring Diagram used in this Job Aid is typical and should be used for training purposes only. Always use the Wiring Diagram supplied with the product when servicing the unit.

GOALS AND OBJECTIVES

The goal of this Job Aid is to provide information that will enable the In-Home Service Professional to properly diagnose malfunctions and repair the "Direct Drive FL Washer"

The objectives of this Job Aid are to:

- Understand and follow proper safety precautions.
- Successfully troubleshoot and diagnose malfunctions.
- Successfully perform necessary repairs.
- Successfully return the washer to its proper operational status.

WHIRLPOOL CORPORATION assumes no responsibility for any repairs made on our products by anyone other than authorized In-Home Service Professionals.

TABLE OF CONTENTS

	Page
SAFETY FIRST	1-1
Model & Serial Number Designations.....	1-2
Model & Serial Number Label And Tech Sheet Locations.....	1-3
Specifications	1-4
INSTALLATION INFORMATION	2-1
Installation Information.....	2-1
Installation Instructions.....	2-4
PRODUCT OPERATION	3-1
Control Panel And Features.....	3-1
Using The Washer.....	3-5
Washer Maintenance.....	3-11
Troubleshooting.....	3-14
COMPONENT ACCESS	4-1
Component Locations.....	4-1
Removing The Dispenser Drawer Top And Console Assembly	4-2
Removing The Central Control Unit.....	4-4
Removing The Water Inlet Valve	4-6
Removing The Pressure Switch.....	4-7
Removing The Line Filter & Power Supply Cord.....	4-8
Removing The Detergent Dispenser Assembly.....	4-9
Removing The Detergent Dispenser Motor.....	4-11
Removing The Door Switch Assembly Front Panel And Bellows.....	4-12
Removing The Drain Pump.....	4-14
Removing The Eco Valve.....	4-15
Removing The Motor Control Unit	4-16
Removing The Vent / Fan	4-17
Removing The Temperature Sensor & Heater	4-18
Removing The Motor.....	4-19
Removing The Tub Assembly`	4-21
COMPONENT TESTING	5-1
For Service Technicians Use Only	5-1
User Interface.....	5-2
Diagnostic Guide.....	5-3
Service Diagnostic Mode.....	5-3
Activating Service Diagnostic Mode.....	5-3
Unsuccessful Activation.....	5-4
Quick Diagnostic Test.....	5-5
Advancing Through Saved Fault / Error Codes	5-6
Test Procedures.....	5-7
Pressure Switch (Non-Steam Models).....	5-12
TEST #8: Drain Pump	5-13
Manually Unlocking the Door Lock System	5-16

TABLE OF CONTENTS (continued)

	Page
DIAGNOSTICS & TROUBLESHOOTING	6-1
Troubleshooting Guide	6-1
Fault/Error Codes	6-4
WIRING DIAGRAMS	7-1
Washer Non-Steam	7-1
Washer Steam	7-2

SAFETY FIRST

Your safety and the safety of others are very important.

We have provided many important safety messages in this manual and on your appliance. Always read and obey all safety messages.



This is the safety alert symbol.

This symbol alerts you to potential hazards that can kill or hurt you and others.

All safety messages will follow the safety alert symbol and either the word “DANGER” or “WARNING.” These words mean:

! DANGER

You can be killed or seriously injured if you don't immediately follow instructions.

! WARNING

You can be killed or seriously injured if you don't follow instructions.

All safety messages will tell you what the potential hazard is, tell you how to reduce the chance of injury, and tell you what can happen if the instructions are not followed.

MODEL & SERIAL NUMBER DESIGNATIONS

MODEL NUMBER	W	F	W	9	4	HE	X	L	0
BRAND									
W = WHIRLPOOL									
ACCESS									
F = Front Load T = Top LOAD									
PRODUCT									
W = WASHER									
SERIES									
5=Whirlpool Leap 6=Oasis									
7=24" Front Load 8=Mid Line Front Load									
9=Duet Front Load									
PRICE POINT LEVELS (1-9)									
HIGH EFFICIENCY									
YEAR OF INTRODUCTION									
X = 2010									
COLOR CODE									
L= Pewter									
ENGINEERING CHANGE (0, 1, 2, ETC.)									

SERIAL NUMBER	CK	X	41	01002
DIVISION RESPONSIBILITY				
C = CLYDE, OH K = SHANGHAI, CHINA				
YEAR OF PRODUCTION				
X = 2010				
WEEK OF PRODUCTION				
41 = 41ST WEEK				
PRODUCT SEQUENCE NUMBER				

MODEL & SERIAL NUMBER LABEL AND TECH SHEET LOCATIONS

The Model & Serial Number Label and Tech Sheet locations are shown below.

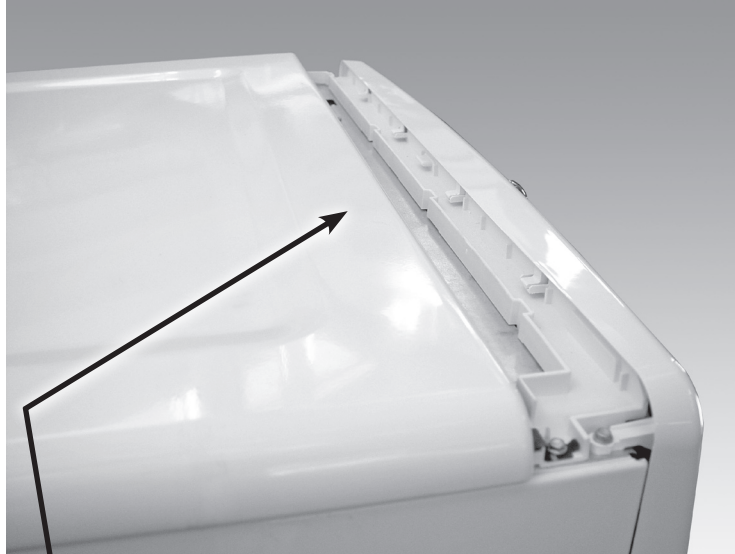

Tech Sheet is taped to the bottom of the top panel, see the "COMPONENT ACCESS" section for top removal procedures.



Model & Serial Number

SPECIFICATIONS

Model Fuel Type	Electric
Main Characteristics	
Capacity (Cu.Ft. IEC)	5.0
Controls	Electronic
Controls Location	Front controls with cycle indicator lights
Detergent Dispenser	Yes
Dispenser Type	3-Tray Dispenser Drawer
Drum Tub Material	Stainless Steel wash basket
Heater	Built-in water heater
5.0 Cu. Ft, Stainless Steel Wash Basket	•
ENERGY STAR® Qualified	•
CEE Tier III Qualified	•
1,400 RPM Maximum Spin Speed	•
Direct Inject Wash System	•
Cycles	
Number of Cycles	10
Clean Washer	Clean Washer with Affresh™
Delicate	Yes
Hand Wash	Yes
Heavy Duty	Yes
Normal	Yes
Quick Wash	Yes
Whitest Whites	Yes
Wash/Rinse Temperatures	
Cold/Cold	Yes
Warm/Cold	Yes
Number of Temperatures	5
Temperature Control	Care Control Temperature Management
Options	
Auto Soak	PreSoak
Delay Start	12 hour delay start
Extra Rinse	Yes
Spin Speeds	
High	Yes
Low	Yes
No Spin	Yes
Number of speeds	5

SPECIFICATIONS (continued)

Control Locked	Yes
Door Locked	Yes
Est. Time Remaining	Yes
Approvals	
ADA Compliant	•

Dimensions	In.
Carton Depth	35
Carton Height	39 3/4
Carton Width	28 3/4
Height	38
Width	27
Gross Weight	250lbs

INSTALLATION INFORMATION

Tools and Parts

Gather required tools and parts before starting installation.

Tools needed:

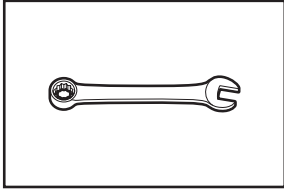

Adjustable or open end wrenches $\frac{1}{2}$ " (13 mm) and $\frac{9}{16}$ " (14 mm)

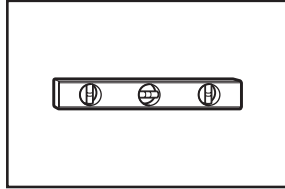

Level

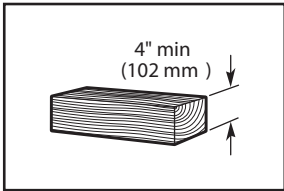

Wood block

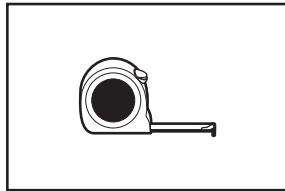

Ruler or measuring tape

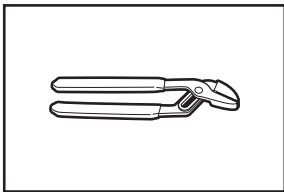

Pliers that open to $1 \frac{9}{16}$ " (39.5 mm)

Parts supplied:

NOTE: All parts supplied for installation are in the washer basket.

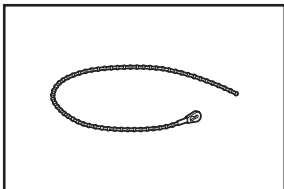

Beaded tie strap

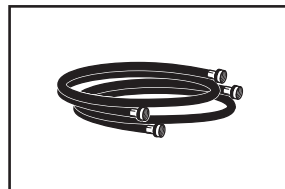

Inlet hoses (2) with washers

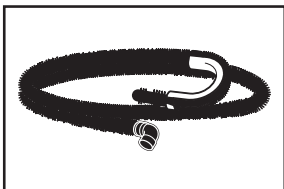

Drain hose with clamp and form (may be shipped unassembled)

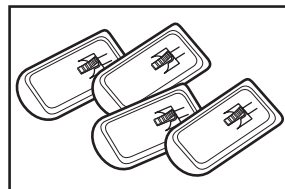

Transport bolt hole plugs (4)

Optional tools:

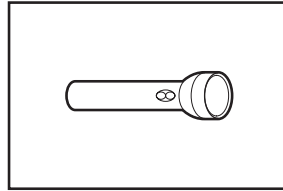

Flashlight

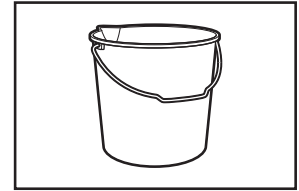

Bucket

Available Accessories:

An optional matching pedestal is available for your washer. Please contact your retailer for ordering information, or see the Assistance or Service page on the back of your Use and Care Guide.

Alternate parts: (Not supplied with washer)

Your installation may require additional parts. To order, please refer to toll-free numbers on the back page of your Use and Care Guide.

If you have:

Overhead sewer

1" (25 mm) standpipe

Drain hose too short

Lint clogged drain

Floor drain system

You will need:

Standard 20 gal. (76 L) 39" (990 mm) tall drain tub or utility sink, sump pump and connectors (available from local plumbing suppliers)

2" (51 mm) diameter to 1" (25 mm) diameter Standpipe Adapter Part Number 3363920
Connector Kit Part Number 285835

Extension Drain Hose Part Number 285863
Connector Kit Part Number 285835

Drain Protector Part Number 367031
Connector Kit Part Number 285835

Siphon Break Kit Part Number 285834
Connector Kit (x2) Part Number 285835
Extension Drain Hose Part Number 285863

Alternative Inlet Hoses:

(may be required for some installations, not supplied with washer)

- 8212656RP 10 ft. (3.0 m) Inlet hose, Black EPDM (2 pack)
- 8212641RP 5 ft. (1.5 m) Inlet hose, Black EPDM (2 pack)
- 8212546RP 4 ft. (1.2 m) Inlet hose, Black EPDM (2 pack)
- 8212545RP 5 ft. (1.5 m) Inlet hose, Red and Blue EPDM (2 pack)
- 8212487RP 5 ft. (1.5 m) Nylon braided inlet hose (2 pack)
- 8212638RP 6 ft. (1.8 m) Nylon braided inlet hose, space saving 90° elbow, hypro-blue steel couplings (2 pack)
- 8212637RP 6 ft. (1.8 m) Inlet hose, Black EPDM, space saving 90° elbow, hypro-blue steel couplings (2 pack)

LOCATION REQUIREMENTS

Proper installation is your responsibility.

You will need:

- A water heater set to 120° F (49° C).
- A grounded electrical outlet located within 6 ft (1.8 m) of power cord on back of washer.
- Hot and cold water faucets located within 4 ft (1.2 m) of hot and cold water fill valves on washer, and water pressure of 20-100 psi (137.9-689.6 kPa).
- A level floor with maximum slope of 1" (25 mm) under entire washer. Installing on carpet or surfaces with foam backing is not recommended.
- Floor must support washer's total weight (with water and load) of 315 lbs (143 kgs).

IMPORTANT: Do not install, store or operate washer where it will be exposed to weather or in temperatures below 32° F (0° C). Water remaining in washer after use may cause damage in low temperatures. See "Washer Care" in Washer Use and Care Guide for winterizing information.

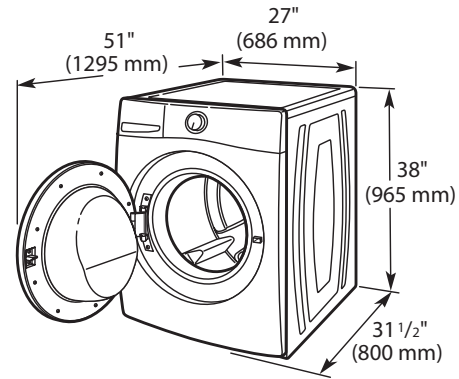

All dimensions show recommended spacing allowed, except for closet door ventilation openings which are the minimum required.

For each arrangement, consider allowing more space for ease of installation and servicing, and spacing for companion appliances and clearances for walls, doors, and floor moldings.

Space must be large enough to allow door to fully open. Add spacing of 1" (25 mm) on all sides of washer to reduce noise transfer. If a closet door or louvered door is installed, top and bottom air openings in door are required.

Recessed area or closet installation (stacked washer and dryer):

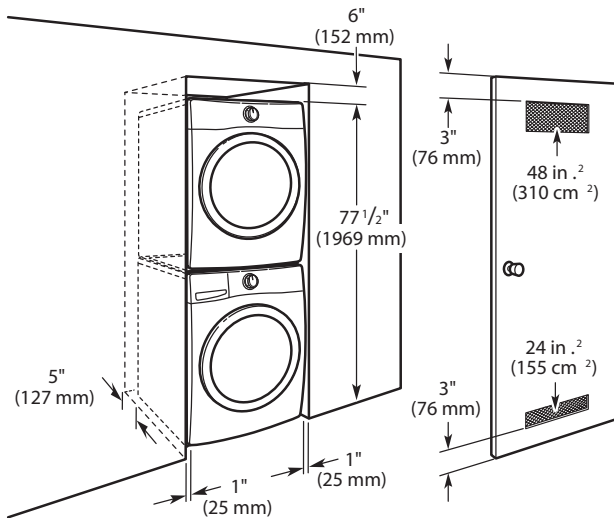

Custom under counter installation:

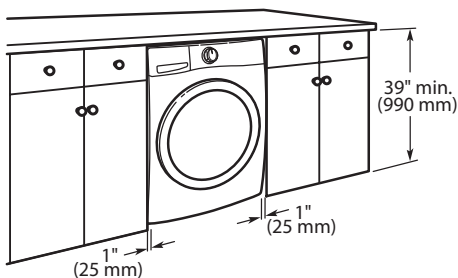

Recessed area or closet installation (washer only):

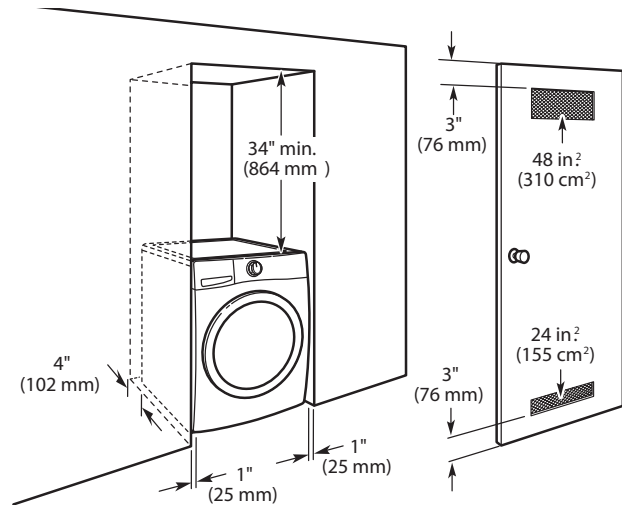

Custom cabinet installation:

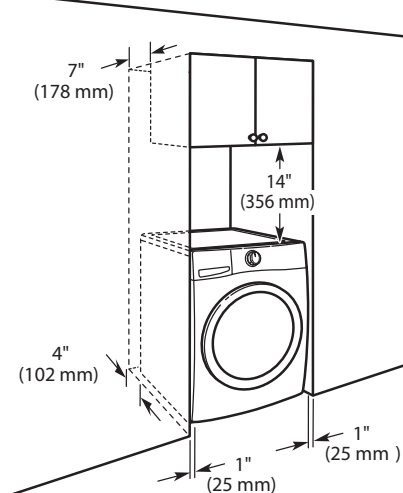

DRAIN SYSTEM

DRAIN SYSTEM

Drain system can be installed using a floor drain, wall standpipe, or laundry tub. Select method you need.

IMPORTANT: To avoid siphoning, only 4.5" (113 mm) of drain hose should be inside standpipe. Always secure drain hose with beaded tie strap.

Floor standpipe drain system

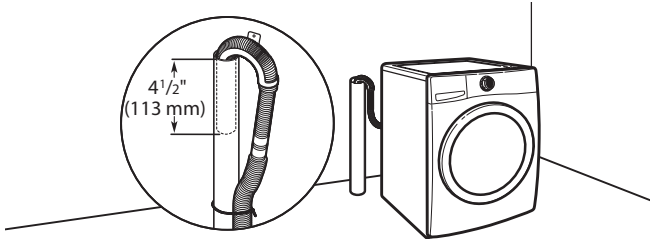

Minimum diameter for a standpipe drain: 2" (51 mm). Minimum carry-away capacity: 17 gal. (64 L) per minute. A 1/4" (6 mm) diameter to 1" (25 mm) diameter Standpipe Adapter Kit is available (Part Number 3363920). Top of standpipe must be at least 30" (762 mm) high; install no higher than 96" (2.44 m) from bottom of washer. If you have an overhead sewer and need to pump higher than 96 inches, a sump pump and associated hardware are needed. See "Alternative Parts".

Wall standpipe drain system

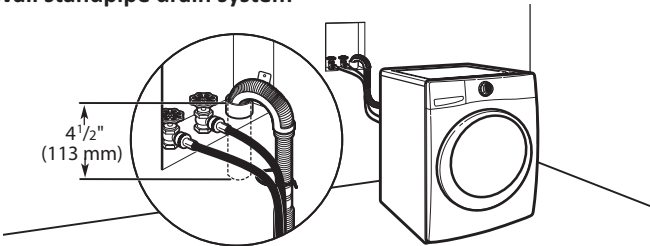

See requirements for floor standpipe drain system.

Laundry tub drain system

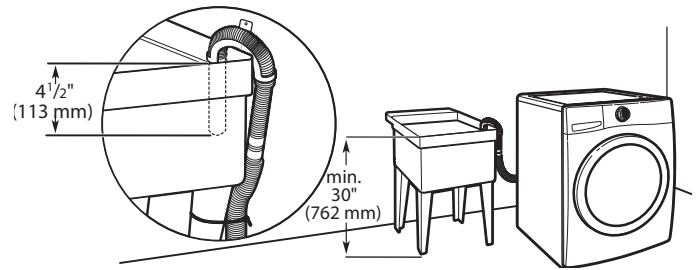

Minimum capacity: 20 gal. (76 L). Top of laundry tub must be at least 30" (762 mm) above floor; install no higher than 96" (2.44 m) from bottom of washer.

Floor drain system

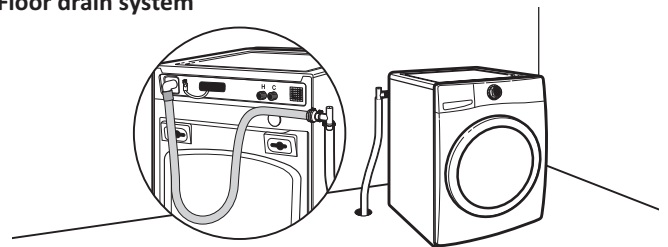

Floor drain system requires a Siphon Break Kit (Part Number 285834), 2 Connector Kits (Part Number 285835), and an Extension Drain Hose (Part Number 285863) that may be purchased separately. See "Alternative Parts". Minimum siphon break height: 28" (710 mm) from bottom of washer. (Additional hoses may be needed.)

ELECTRICAL REQUIREMENTS

⚠ WARNING



Electrical Shock Hazard

Plug into a grounded 3 prong outlet.

Do not remove ground prong.

Do not use an adapter.

Do not use an extension cord.

Failure to follow these instructions can result in death, fire, or electrical shock.

- A 120 volt, 60 Hz., AC only, 15- or 20-amp, fused electrical supply is required. A time-delay fuse or circuit breaker is recommended. It is recommended that a separate circuit breaker serving only this appliance be provided.
- This washer is equipped with a power supply cord having a 3 prong grounding plug.
- To minimize possible shock hazard, the cord must be plugged into a mating, 3 prong, grounding-type outlet, grounded in accordance with local codes and ordinances. If a mating outlet is not available, it is the personal responsibility and obligation of the customer to have the properly grounded outlet installed by a qualified electrician.
- If codes permit and a separate ground wire is used, it is recommended that a qualified electrician determine that the ground path is adequate.
- Do not ground to a gas pipe.
- Check with a qualified electrician if you are not sure the washer is properly grounded.
- Do not have a fuse in the neutral or ground circuit.

GROUNDING INSTRUCTIONS

For a grounded, cord-connected washer:

This washer must be grounded. In the event of a malfunction or breakdown, grounding will reduce the risk of electrical shock by providing a path of least resistance for electric current. This washer is equipped with a cord having an equipment-grounding conductor and a grounding plug. The plug must be plugged into an appropriate outlet that is properly installed and grounded in accordance with all local codes and ordinances.

WARNING: Improper connection of the equipment grounding conductor can result in a risk of electric shock. Check with a qualified electrician or serviceman if you are in doubt as to whether the appliance is properly grounded.

Do not modify the plug provided with the appliance – if it will not fit the outlet, have a proper outlet installed by a qualified electrician.

For a permanently connected washer:

This washer must be connected to a grounded metal, permanent wiring system, or an equipment grounding conductor must be run with the circuit conductors and connected to the equipment-grounding terminal or lead on the appliance.

INSTALLATION INSTRUCTIONS

⚠ WARNING

Excessive Weight Hazard

Use two or more people to move and install washer.

Failure to do so can result in back or other injury.

NOTE: To avoid floor damage, set washer onto cardboard before moving it.

1. Move washer

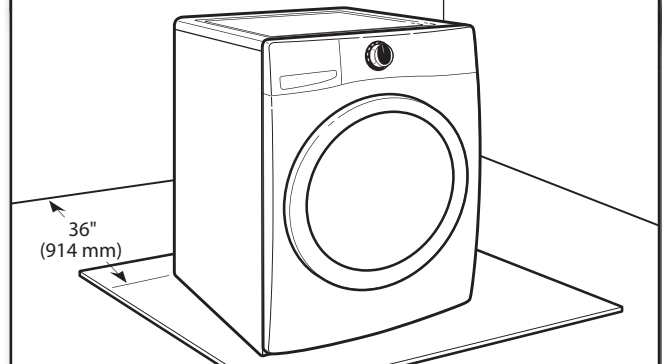

It is necessary to remove all shipping materials for proper operation and to avoid excessive noise from washer.

Move washer to within 4 ft (1.2 m) of its final location. It must be in a fully upright position.

2. Locate transport bolts

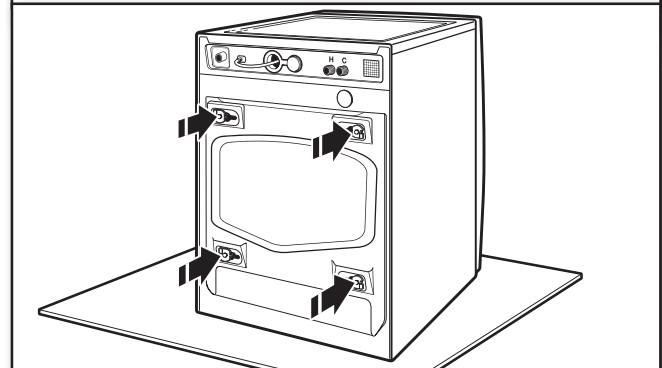

Locate four transport bolts on rear of washer.

INSTALLATION INSTRUCTIONS (continued)

3. Remove transport bolts from washer

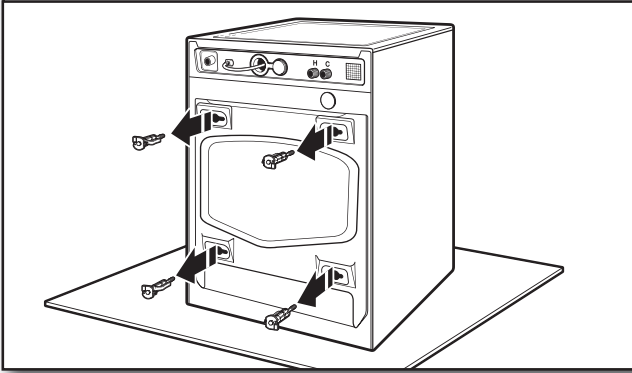

Loosen bolts with a 13 mm (1/2") wrench. Slide each bolt and spacer to center of hole. Pull bolts and plastic spacers from back of washer. Discard bolts and spacers.

4. Cover bolt holes with transport bolt hole plugs

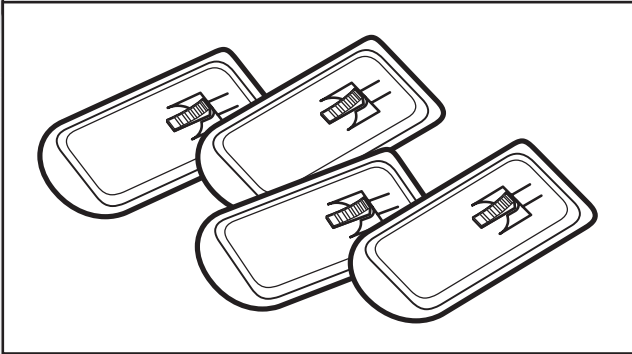

Close bolt holes on cabinet back with four transport bolt hole plugs included with washer parts.

5. Remove power cord

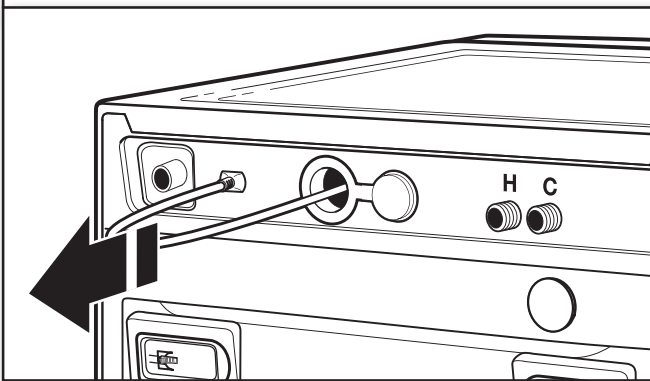

Pull power cord through opening in rear panel and close hole with attached cap.

NOTE: If washer is transported at later date, call your local service center to avoid suspension and structural damage, a certified technician must properly set up washer for relocation.

6. Place power cord over top

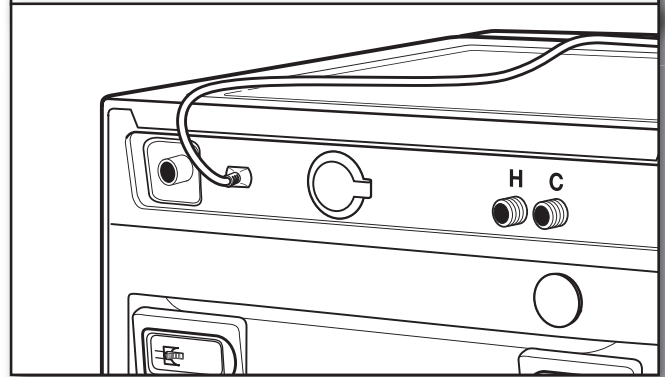

Remove the yellow shipping strap from the cord. Gently place power cord over top of washer to allow free access to back of washer.

CONNECT DRAIN HOSE

7. Attach drain hose to drain port

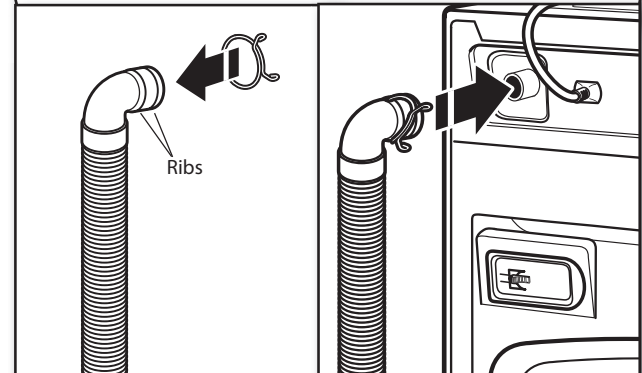

If clamp is not already in place on elbow end of drain hose, slide it over end of hose, centering it between the ribs, as shown. Squeeze clamp with pliers and slide elbow end of drain hose onto drain port and secure with clamp.

For a laundry tub or standpipe drain, go to step 9.

For a floor drain, remove the preinstalled drain hose form as shown in Step 8. You may need additional parts with separate directions. See "Alternative Parts".

INSTALLATION INSTRUCTIONS (continued)

8. Remove drain hose form (floor drain installations only)

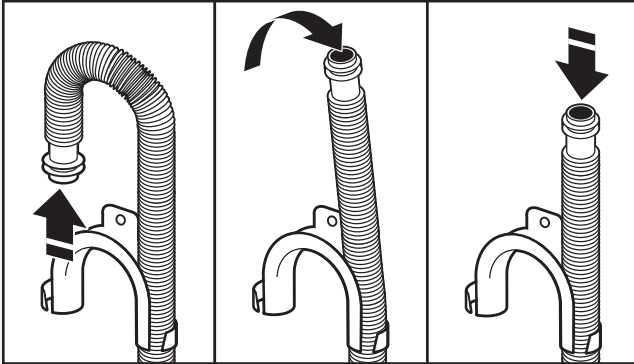

For floor drain installations, you will need to remove the drain hose form from the end of the drain hose. You may need additional parts with separate directions. See "Alternative Parts".

9. Place drain hose in standpipe

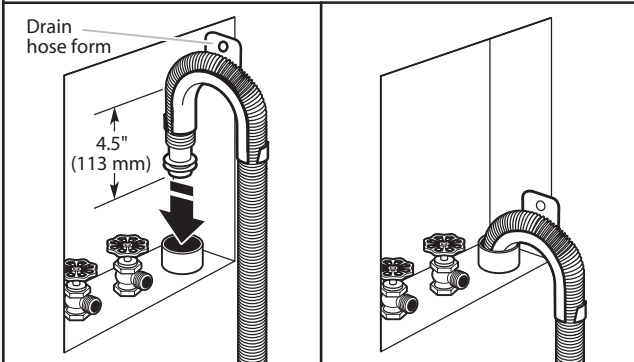

Place hose into standpipe (shown in picture) or over side of laundry tub.

IMPORTANT: Only 4.5" (113 mm) of drain hose should be inside standpipe; do not force excess hose into standpipe or lay on bottom of laundry tub. Drain hose form must be used.

CONNECT INLET HOSES

Washer must be connected to water faucets with new inlet hoses with flat washers. Do not use old hoses.

NOTE: Both hoses must be attached and have water flowing to inlet valves. For optimal performance, hot and cold water must be supplied to the washer.

10. Connect inlet hoses to water faucets

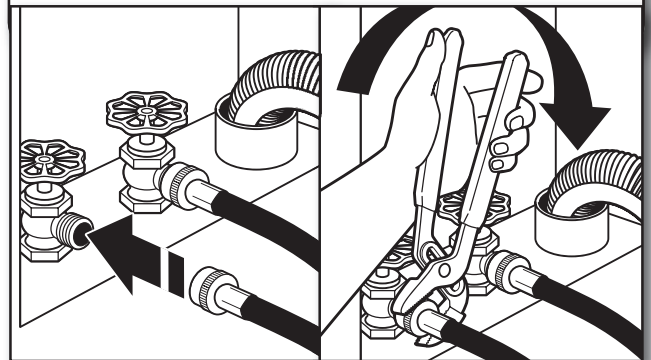

Attach hose to hot water faucet. Screw on coupling by hand until it is seated on washer. Use pliers to tighten couplings an additional two-thirds turn. Repeat this step with second hose for cold water faucet.

IMPORTANT: Do not overtighten or use tape or sealants on valve when attaching to faucets or washer. Damage can result.

HELPFUL TIP: Make note of which hose is connected to hot water to help in attaching hoses to washer correctly. In most standard configurations, hoses will cross over each other when attached correctly.

11. Clear water lines

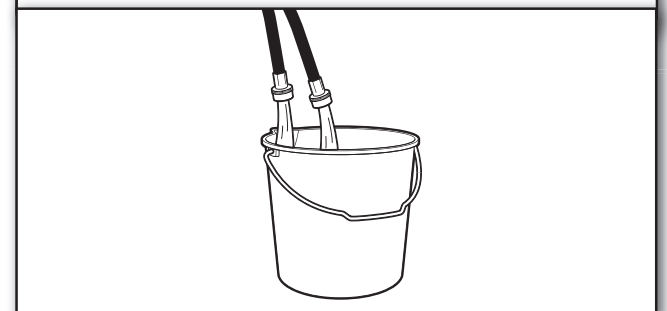

Run water for a few seconds through hoses into a laundry tub, drainpipe, or bucket to prevent clogs. Water should run until clear.

INSTALLATION INSTRUCTIONS (continued)

12. Connect inlet hoses to washer

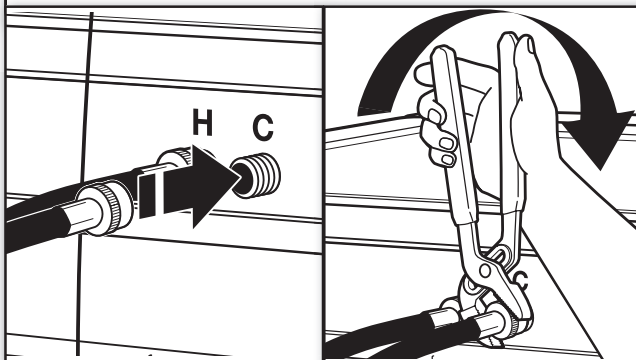

Attach hot water hose to hot water inlet valve marked with a red ring. Screw coupling by hand until it is snug. Use pliers to tighten couplings an additional two-thirds turn. Repeat with cold water inlet valve.

IMPORTANT: To reduce risk of hose failure, replace the hoses every 5 years. Record hose installation or replacement dates for future reference.

- Periodically inspect and replace hoses if bulges, kinks, cuts, wear, or leaks are found.

13. Check for leaks

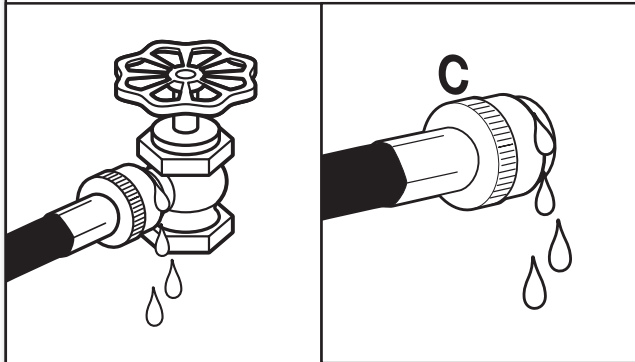

Slowly turn on water faucets to check for leaks. A small amount of water may enter washer. It will drain later.

14. Secure drain hose

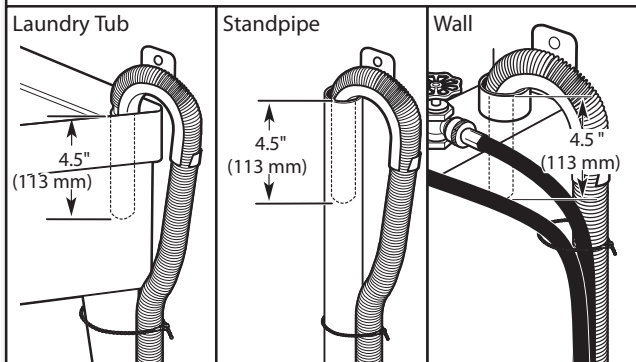

Secure drain hose to laundry tub leg, drain standpipe, or inlet hoses for wall standpipe with beaded tie strap.

LEVEL WASHER

Leveling your washer properly reduces excess noise and vibration.

15. Check levelness of washer

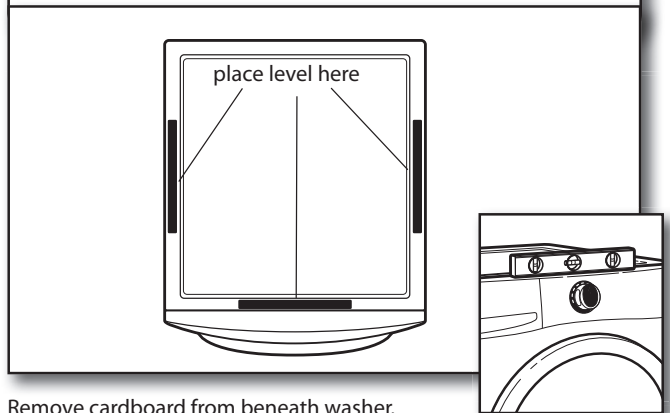

Remove cardboard from beneath washer. Place a level on top edges of washer, checking each side and front. If not level, tip washer and adjust feet up or down as shown in steps 17 and 18, repeating as necessary.

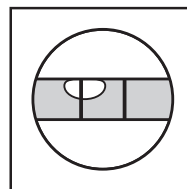

Not Level

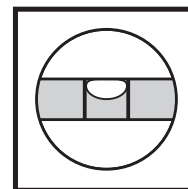

LEVEL

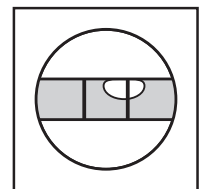

Not Level

16. Rock washer to test foot contact

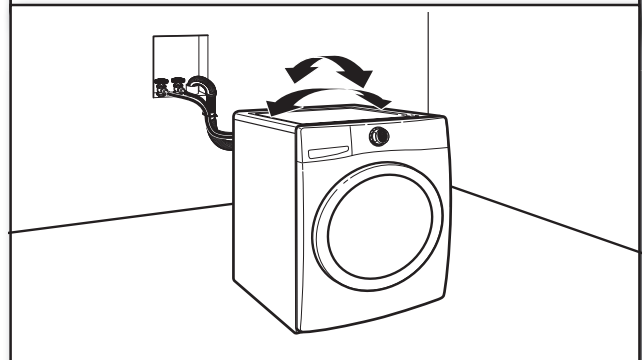

Grip washer from top and rock back and forth, making sure all four feet are firmly on floor. Repeat, rocking washer from side to side. If washer rocks, go to step 17 and adjust leveling feet. If all four feet are in firm contact with floor, go to Step 18.

INSTALLATION INSTRUCTIONS (continued)

17. Adjust leveling feet

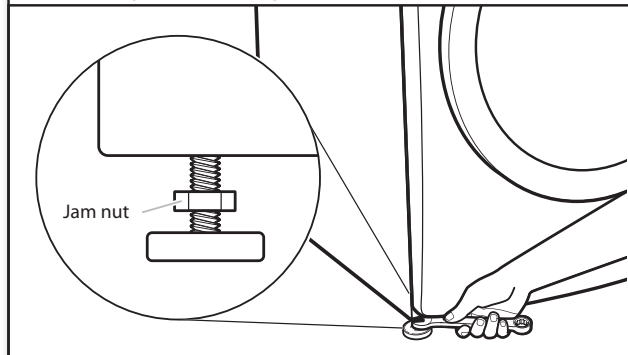

If washer is not level, use a 9/16" or 14 mm open-end or adjustable wrench to turn jam nuts clockwise on feet until they are about 1/2" (13 mm) from the washer cabinet. Then turn the leveling foot clockwise to lower the washer or counterclockwise to raise the washer. Recheck levelness of washer and that all four feet are firmly in contact with the floor. Repeat as needed.

HELPFUL TIP: You may want to prop up front of washer about 4" (102 mm) with a wood block or similar object that will support weight of washer.

18. Tighten leveling feet

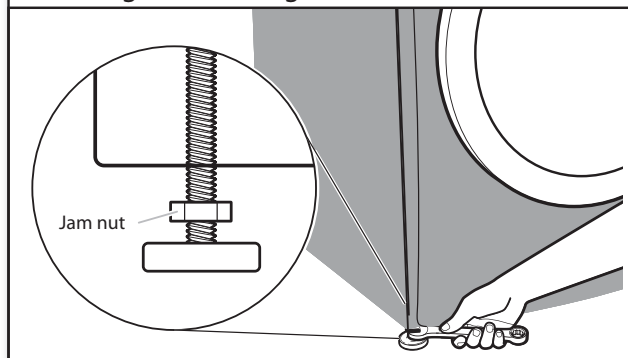

When washer is level and all four feet are firmly in contact with the floor, use a 9/16" or 14 mm open-end or adjustable wrench to turn jam nuts counterclockwise on leveling feet tightly against washer cabinet.

HELPFUL TIP: You may want to prop washer with wooden block.

⚠ WARNING



Electrical Shock Hazard

Plug into a grounded 3 prong outlet.

Do not remove ground prong.

Do not use an adapter.

Do not use an extension cord.

Failure to follow these instructions can result in death, fire, or electrical shock.

20. Plug into a grounded 3 prong outlet

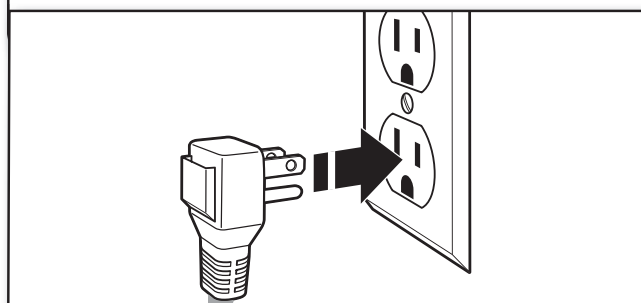

COMPLETE INSTALLATION CHECK LIST

- Check electrical requirements. Be sure you have correct electrical supply and recommended grounding method.
- Check that all parts are now installed. If there is an extra part, go back through steps to see what was skipped.
- Check that you have all of your tools.
- Check that transport materials were completely removed from back of washer.
- Check that both hot and cold hoses are attached and water faucets are on.
- Check for leaks around faucets, valves, and inlet hoses.
- Remove protective film from console and any tape remaining on washer.
- Check that washer is plugged into a grounded 3 prong outlet.
- Dispose of/recycle all packaging materials.
- Read "Using Your Washer" in your Washer Use and Care Guide.
- To test and clean your washer, press power and choose the QUICK WASH cycle and run it without clothes. Use only HE detergent. Use 1/2 the manufacturer's recommended amount for a medium-size load.

PRODUCT OPERATION

CONTROL PANEL AND FEATURES

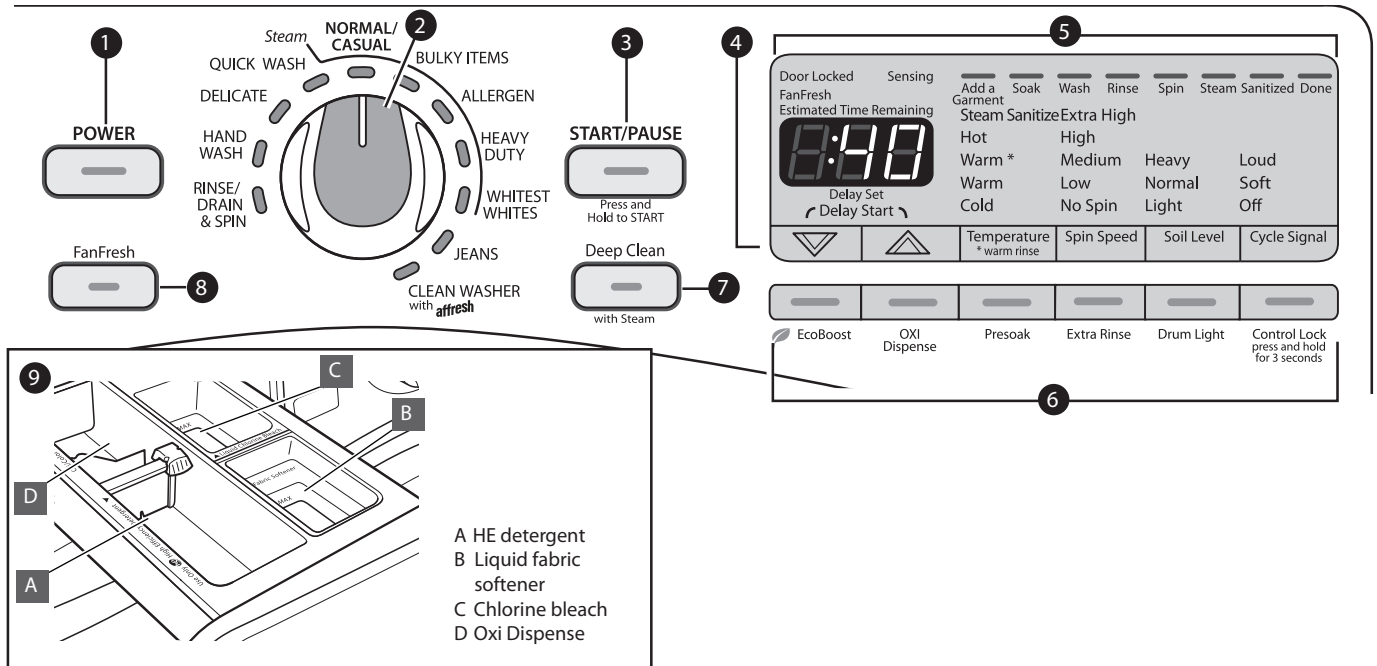

Non-Steam models

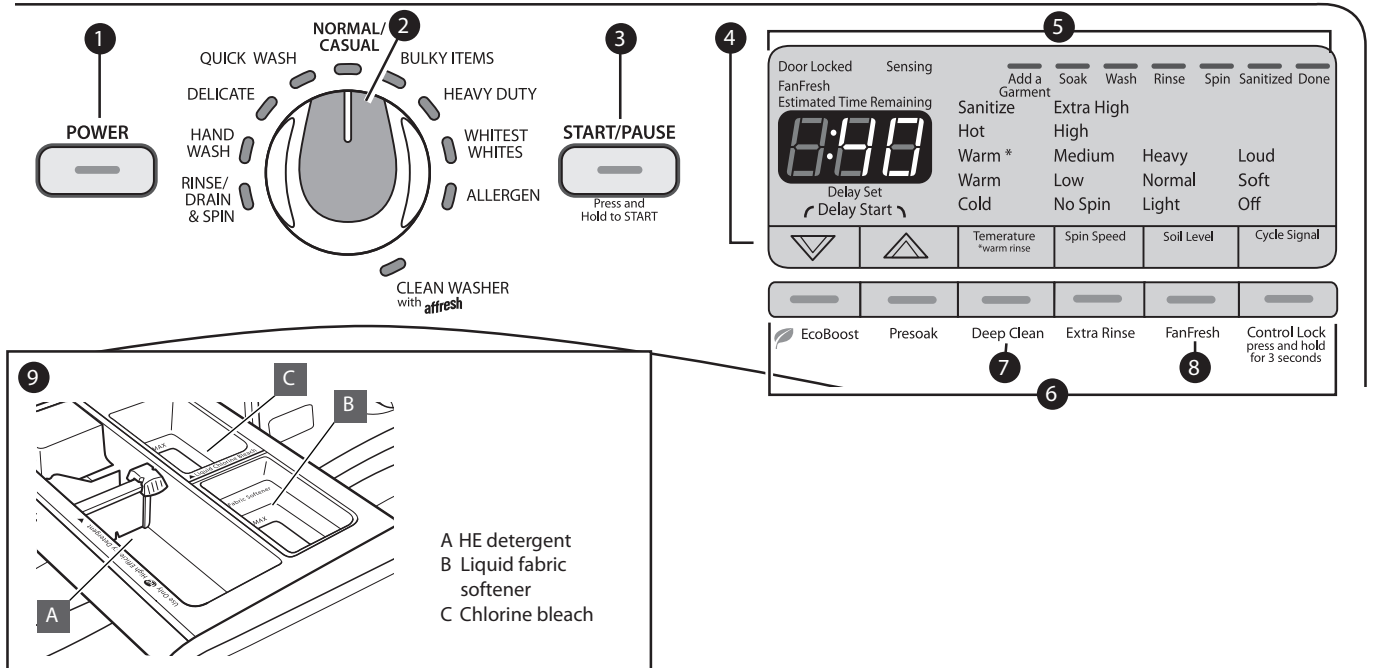

1 POWER BUTTON

Press to turn the washer on and off.
Press to stop/cancel a cycle at any time.

2 WASH CYCLE KNOB

Use your Wash Cycle Knob to select available cycles on your washer. Turn the knob to select a cycle for your laundry load. See "Cycle Guide" for detailed descriptions of cycles.

3 START/PAUSE BUTTON

Press and hold to start a cycle, or press once while a cycle is in process to pause it for up to 5 minutes.

4 DELAY START BUTTONS

Use these buttons to delay the start of the wash cycle by up to 16 hours on models with Steam, and 12 hours on non-Steam models.

CONTROL PANEL AND FEATURES (Continued)

5 LED DISPLAY AND SETTINGS BUTTONS

When you select a cycle, its default settings will light up and the Estimated Time Remaining will be displayed. Factors such as load size, wash temperature, and water pressure may affect the time shown in the display. Overloading, unbalanced loads, or excessive suds may cause the washer to adjust the cycle time, as well.

Use the buttons along the bottom of the display to adjust settings. See "Cycle Guide" for available settings on each cycle. Not all settings are available with all cycles.

Cycle Status Lights

The indicator bar at the top of the display will let you know what stage of the wash cycle is in process, as well as when the door is locked or if you can still add an item. For more information on each stage, see "Cycle Status Lights".

Temperature

The recommended wash temperature is preset for each cycle. You may also select a wash temperature based on the type of fabric and soils being washed. For best results, use the warmest wash water safe for your fabric, following the garment label instructions. All wash temperatures feature a cold rinse, except Warm*, which has a warm wash and a warm rinse.

Spin Speed

This washer automatically selects the spin speed based on the cycle selected. Some preset speeds can be changed.

- Faster spin speeds mean shorter dry times, but may increase wrinkling in your load.
- Slower spin speeds reduce wrinkling, but will leave your load more damp.

Soil Level

Soil level (wash time) is preset for each wash cycle. As you press the Soil Level button, the cycle time will increase or decrease in the Estimated Time Remaining display.

For most loads, use the soil level that is preset with the cycle you have chosen. For heavily soiled and sturdy fabrics, press Soil Level to select more wash time. For lightly soiled and delicate fabrics, press Soil Level to select less wash time. Lower soil level settings will help reduce tangling and wrinkling.

Cycle Signal

Use this option to adjust volume of the signal that sounds at end of cycle.

NOTE: You may also turn off the tones that sound when a button is pressed. Press and hold the EcoBoost button for about one second to turn button sounds on or off.

6 OPTION BUTTONS

Use these buttons to activate additional wash options or additional features on the washer. Not all options are available on all models.

EcoBoost™ option

Press to activate the EcoBoost™ option. The EcoBoost™ option provides additional energy savings through reduced hot water usage and maintains cleaning performance by lengthening the wash time on some cycles.

NOTE: Press and hold the EcoBoost button for about one second to turn button sounds on or off.

Oxi Dispense (on some models)

Turn this option on when using Oxi boost products in the dispenser to ensure they are dispensed at the optimal time in the cycle. Oxi Dispense is not available on the Quick Wash, Delicates, or Handwash cycle.

Presoak

Press to add a Presoak to a wash cycle to help loosen tough stains. On models with Steam, you may add detergent to the Oxi compartment for Presoak.

Extra Rinse

Activate this option to add an extra rinse to most cycles. NOTE: Some cycles include this feature as a default. See "Cycle Guide" for details.

Drum Light (on some models)

Press to turn the LED drum light on or off. The light will also turn on when the door is open, and turn off automatically after about 5 minutes.

Control Lock

Press and hold for 3 seconds to lock the controls to avoid unwanted changes or operation. Press and hold 3 seconds again to unlock. You may still press START/PAUSE to pause the cycle, or press the POWER button to turn the washer off.

7 DEEP CLEAN/DEEP CLEAN with Steam (on some models)

The Deep Clean option adds additional soak and wash time to many cycles to help remove tough stains. An integrated heater helps to maintain optimal wash temperatures. On Steam models, Deep Clean includes a Steam boost for added cleaning power. See the "Cycle Guide" for cycles that allow the Deep Clean option.

8 FANFRESH™ OPTION

With the washer on, press to activate the FanFresh™ option. This will periodically tumble the load after the end of the cycle for up to 16 hours while the integrated fan circulates air through the washer to reduce humidity. You may also activate the FanFresh option without running a cycle by pressing and holding for 3 seconds, then pressing START/PAUSE.

NOTE: The door will lock while the FanFresh option is active. Press the POWER button to stop the cycle and unlock the door.

9 PRECISION DISPENSE DRAWER

The Precision Dispense drawer gives you the convenience of automatically adding HE detergent, liquid chlorine bleach, and fabric softener to the wash load at the proper time. Steam models also feature an Oxi/color-safe bleach compartment. See "Using the Dispenser" for information on using the dispenser drawer.

A High Efficiency "HE" detergent compartment

This compartment holds liquid or powdered HE detergent for your main wash cycle. For models without an Oxi dispenser compartment, liquid or powdered color-safe bleach or Oxi booster product may be added to the HE detergent compartment along with the same type of detergent, liquid or powdered.

B Liquid fabric softener compartment

Automatically dilutes and dispenses liquid fabric softener at the optimum time in the cycle.

- Use only liquid fabric softener in this dispenser.

C Liquid chlorine bleach compartment

Automatically dilutes and dispenses liquid chlorine bleach at the optimum time during the first rinse after the wash cycle. This compartment cannot dilute powdered bleach.

D Oxi Dispense compartment (Steam models only)







This compartment holds measured liquid or powdered Oxi booster product and dispenses it at the proper time in the cycle. Oxi Dispense is not available on the Quick Wash, Delicates, or Handwash cycle. This compartment may also be used to hold detergent when using the Presoak option.

CYCLE GUIDE — STANDARD CYCLES

Settings and options shown in **bold** are default settings for that cycle. For best fabric care, choose the cycle that best fits the load being washed.

Not all cycles and options are available on all models.

For best performance, not all settings are available with each cycle, and some options cannot be used together.

Items to wash using default cycle settings:	Cycle:	Wash Temperature*:	Spin Speed:	Soil Level:	Available Options:	Cycle Details:
Sturdy colorfast fabrics and heavily soiled garments, towels, and jeans	Heavy Duty	Sanitize † Hot Warm* Warm Cold	Extra High High Medium Low No Spin	Heavy Normal Light	Extra Rinse Deep Clean Presoak EcoBoost FanFresh Delay Start	 High-speed tumbling and a high-speed final spin help provide optimal cleaning and reduce drying times.
Normally soiled cottons, linens, sheets, and mixed garment loads	Normal/ Casual	Hot Warm Cold	Extra High High Medium No Spin	Heavy Normal Light	Extra Rinse Deep Clean Presoak FanFresh Delay Start	 This cycle combines medium-speed tumbling and a high-speed spin. This cycle is designed to provide the most energy efficiency.
Heavily soiled white fabrics	Whitest Whites	Sanitize † Hot Warm* Warm Cold	Extra High High Medium Low No Spin	Heavy Normal Light	Extra Rinse Deep Clean Presoak EcoBoost FanFresh Delay Start	 Hot wash temperatures ensure liquid chlorine bleach action. An Extra Rinse helps remove any bleach residue in clothes.
Blankets, comforters	Bulky Items	Sanitize † Hot Warm* Warm Cold	High Medium Low No Spin	Heavy Normal Light	Extra Rinse Deep Clean Presoak EcoBoost FanFresh Delay Start	 Uses an initial soak to completely saturate the load, followed by medium wash speeds and a medium-speed spin to maintain load balance.
Small loads of lightly soiled garments	Quick Wash	Hot Warm Cold	Extra High High Medium Low	Heavy Normal Light	Extra Rinse FanFresh Delay Start	 For small loads (3-4 items) needed quickly. This cycle combines high-speed tumbling, a shortened wash time, and a high-speed spin for reduced drying times.
Sheer fabrics, lingerie, sweaters, and lightly-soiled shirts, blouses, trousers, pants, and dresses	Delicate	Warm* Warm Cold	Extra High High Medium Low No Spin	Normal Light	Extra Rinse FanFresh Delay Start	 This cycle combines low-speed tumbling and low-speed spin for gentle fabric care and reduced wrinkling.
Small loads of items labeled "handwash": undergarments, washable silks	Hand Wash	Warm* Warm Cold	Extra High High Medium Low No Spin	Normal Light	Extra Rinse FanFresh Delay Start	 Similar to the way garments are hand-washed in a sink, this cycle combines periods of low-speed tumbling and soaking. NOTE: Use mesh garment bags as needed.

* All temperature selections feature a Cold rinse, except Warm*, which features a warm wash and a warm rinse.





† Sanitize

Cycles certified by NSF International, an independent, third party testing and certification organization are those with the sanitize temperature selection available. The certification verified that these cycles reduce 99.9% of bacteria typically found on clothing, bedding, and towels. There is no carryover of bacteria between loads after the cycle is complete. Only cycles with sanitize wash temperature selected have been designed to meet the requirements of NSF Protocol P172 for Sanitizing Effectiveness.

Load Size Recommendations

For best results, follow the load size recommendations noted for each cycle.

 **Small load:** Fill the washer drum with 3-4 items, not more than 1/4 full.

 **Medium load:** Fill the washer drum up to about 1/2 full.

 **Large load:** Fill the washer drum up to about 3/4 full.





 **Extra-large load:** Fill the washer drum, but make sure clothes can tumble freely. For best results, avoid packing tightly.

CYCLE GUIDE — SPECIAL-PURPOSE CYCLES

Settings and options shown in **bold** are default settings for that cycle. For best fabric care, choose the cycle that best fits the load being washed.

Not all cycles and options are available on all models.

For best performance, not all settings are available with each cycle, and some options cannot be used together.

Items to wash using default cycle settings:	Cycle:	Wash Temperature*:	Spin Speed:	Soil Level:	Available Options:	Cycle Details:
Swimwear, items that need rinsing only	Rinse /Drain & Spin	Warm* Warm Cold	Extra High High Medium Low No Spin	N/A	Extra Rinse FanFresh Delay Start	 This cycle adds water, then uses high-speed tumbling and an extra high-speed spin. For some fabrics, you may wish to set the spin speed to a lower setting.
Wet load of clothes	Rinse/ Drain & Spin	N/A	Extra High High Medium Low	N/A	FanFresh	 Use Drain & Spin to remove excess water from the load by choosing Rinse/Drain & Spin and turning off Extra Rinse. Spin speed can be set to a lower setting.
Sturdy garments and household items exposed to possible allergens	Allergen**	Sanitize † Hot	Extra High High Medium	Heavy Normal Light	Extra Rinse Deep Clean Presoak FanFresh Delay Start	 Uses more water to flush out allergens such as exposed to dander from normally-soiled items
Jeans and denims (on some models)	Jeans	Warm Cold	Medium Low No Spin	Heavy Normal Light	Extra Rinse Presoak FanFresh Delay Start	 Cycle combines low-speed tumbling and medium-speed spins to provide gentle care for jeans and denims.
No clothes in washer	Clean Washer Cycle					Use monthly with Affresh® to clean the interior of the washer. Make sure no clothes are in washer. The Clean Washer light will flash every 30 loads to remind you to run the Clean Washer cycle.

* All temperature selections feature a Cold rinse, except Warm*, which features a warm wash and a warm rinse.



† Sanitize

Cycles certified by NSF International, an independent, third party testing and certification organization are those with the sanitize temperature selection available. The certification verified that these cycles reduce 99.9% of bacteria typically found on clothing, bedding, and towels. There is no carryover of bacteria between loads after the cycle is complete. Only cycles with sanitize wash temperature selected have been designed to meet the requirements of NSF Protocol P172 for Sanitizing Effectiveness.



†† Allergen

Allergen cycle certified by NSF International, an independent, third party testing and certification organization. The certification verified that this cycle reduced tested allergens by at least 95.0% and maintained the water temperature necessary to kill dust mites. Only the allergen cycle has been designed to meet the requirements of NSF Protocol P351 for Allergen Reduction Performance effectiveness.

USING THE WASHER

⚠ WARNING



Fire Hazard

Never place items in the washer that are dampened with gasoline or other flammable fluids.

No washer can completely remove oil.

Do not dry anything that has ever had any type of oil on it (including cooking oils).

Doing so can result in death, explosion, or fire.

⚠ WARNING



Electrical Shock Hazard

Plug into a grounded 3 prong outlet.

Do not remove ground prong.

Do not use an adapter.

Do not use an extension cord.

Failure to follow these instructions can result in death, fire, or electrical shock.

First wash cycle without laundry

Before washing clothes for the first time, if not completed during the final installation step, choose the QUICK WASH cycle and run it without clothes. Use only HE detergent. Use 1/2 the manufacturer's recommended amount for a medium-size load. This initial cycle serves to ensure the interior is clean before washing clothes.

Choosing the Right Detergent

Use only High Efficiency detergents. The package will be marked "HE" or "High Efficiency." Low-water washing creates excessive sudsing with a regular non-HE detergent. Using regular detergent will likely result in longer cycle times and reduced rinsing performance. It may also result in component failure and, over time, build-up of mold or mildew. HE detergents are made to produce the right amount of suds for the best performance. Follow the manufacturer's instructions to determine the amount of detergent to use.



Use only High Efficiency (HE) detergent.

1. Sort and prepare your laundry

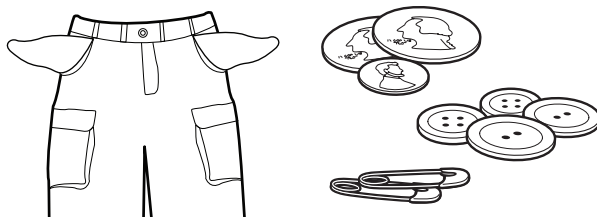

Sort items by recommended cycle, water temperature, and colorfastness. Separate heavily soiled items from lightly soiled. Separate delicate items from sturdy fabrics. Treat stains promptly and check for colorfastness by testing stain remover products on an inside seam.

IMPORTANT:

- Empty pockets. Loose change, buttons, or any small object can plug pumps and may require a service call.
- Close zippers, fasten hooks, tie strings and sashes, and remove non-washable trim and ornaments.
- Mend rips and tears to avoid further damage to items during washing.
- Turn knits inside out to prevent pilling. Separate lint-takers from lint-givers. Synthetics, knits, and corduroy fabrics will pick up lint from towels, rugs, and chenille fabrics.
- Do not dry garments if stains remain after washing, because heat can set stains into fabric.
- Always read and follow fabric care labels and laundry product instructions. Improper usage may cause damage to your garments.

2. Load laundry into washer

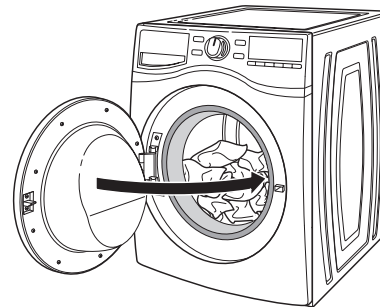

Open the washer door. Place a load of sorted clothes loosely in the washer. Items need to move freely for best cleaning and to reduce wrinkling and tangling. Close the washer door by pushing it firmly until the latch clicks.

- Depending on load type and cycle, the washer can be fully loaded, but not tightly packed. Washer door should close easily. See "Cycle Guide" for loading suggestions.
- Mix large and small items and avoid washing single items. Load evenly.
- Wash small items in mesh garment bags. For multiple items, use more than one bag and fill bags equally.

USING THE WASHER (Continued)

Using the Dispenser

To use the Precision Dispense drawer:

1. Open the dispenser drawer.
2. Add laundry products as described in steps 3–6.
3. Slowly close the dispenser drawer. Make sure it is completely closed.

NOTE: A small amount of water may remain in the dispensers from the previous wash cycle. This is normal.

3. Add HE detergent to dispenser

Models with a 4-compartment dispenser

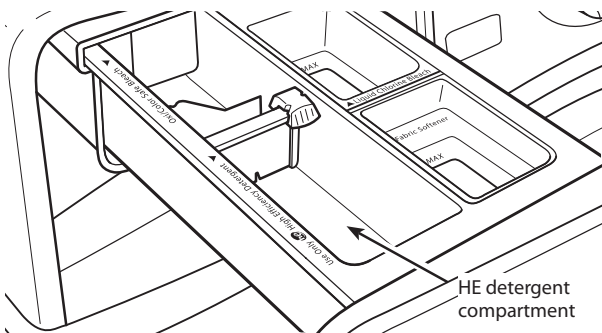

Pour a measured amount of HE detergent into detergent compartment. For powdered detergent, slide the selector to the left. For liquid detergent, slide the selector to the right.

Do not overfill; adding too much detergent may cause detergent to be dispensed into the washer too early.



Use only High Efficiency (HE) detergent.

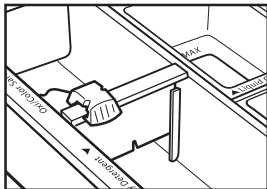

Powdered detergent:
Slide the selector to the left.

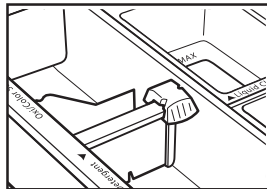

Liquid detergent:
Slide the selector to the right.

When using the Presoak option, 1/3 of the detergent for the load may be placed in the Oxi compartment in place of an Oxi product.

IMPORTANT: Use powdered detergent when using the Delay Wash option. Liquid detergent may seep out before the wash begins.

Models with a 3-compartment dispenser

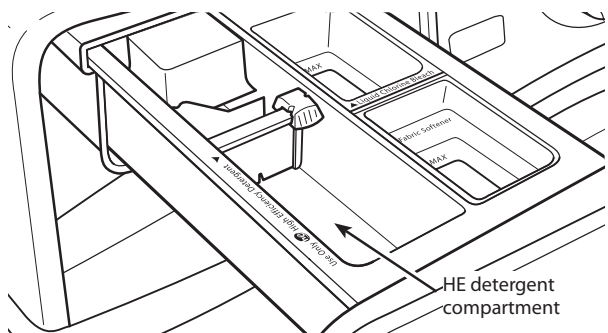

Pour a measured amount of HE detergent into detergent compartment. For powdered detergent, slide the selector to the left. For liquid detergent, slide the selector to the right.

Do not overfill; adding too much detergent may cause detergent to be dispensed into the washer too early.



Use only High Efficiency (HE) detergent.

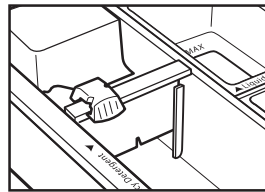

Powdered detergent:
Slide the selector to the left.

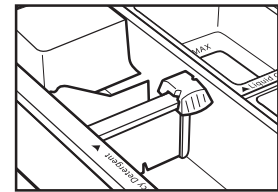

Liquid detergent:
Slide the selector to the right.

You may add powdered or liquid oxi-type boosters or color-safe bleach to the detergent compartment with the same type of detergent, powdered or liquid.

IMPORTANT: Use powdered detergent when using the Delay Wash option. Liquid detergent may seep out before the wash begins.

USING THE WASHER (Continued)

4. Add fabric softener to dispenser (if desired)

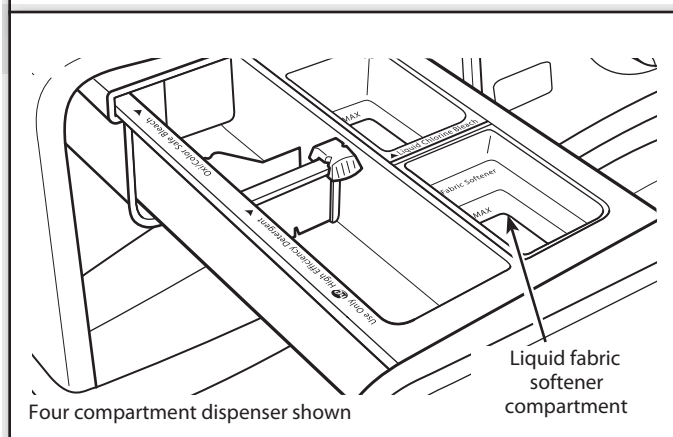

Pour a measured amount of liquid fabric softener into liquid fabric softener compartment. Always follow manufacturer's directions for correct amount of fabric softener based on your load size.

Fabric softener is always dispensed in the last rinse, even if Extra Rinse is selected.

IMPORTANT: Do not overfill, dilute, or use more than 1/4 cup (60 mL) of fabric softener. Do not fill past the MAX line. Overfilling dispenser will cause fabric softener to immediately dispense into washer.

- Do not spill or drip any fabric softener onto the clothes.
- Do not use liquid fabric softener dispenser balls in this washer. They will not dispense correctly.

5. Add liquid chlorine bleach to dispenser (if desired)

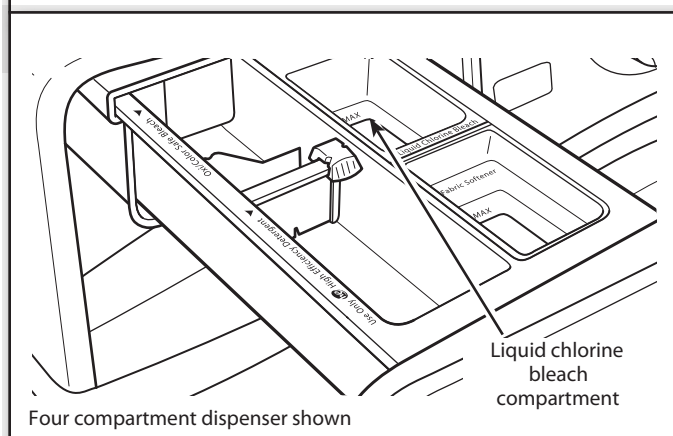

Add a measured amount of liquid chlorine bleach to the bleach compartment. Do not overfill, dilute, or use more than 2/3 cup (165 mL). Use a measuring cup with a pour spout; do not guess.

- Do not fill beyond the "MAX" level. Overfilling will cause bleach to dispense too soon and may cause garment damage.
- Do not add color-safe bleach or oxi-product to this dispenser.

6. Add Oxi or color safe bleach (on some models)

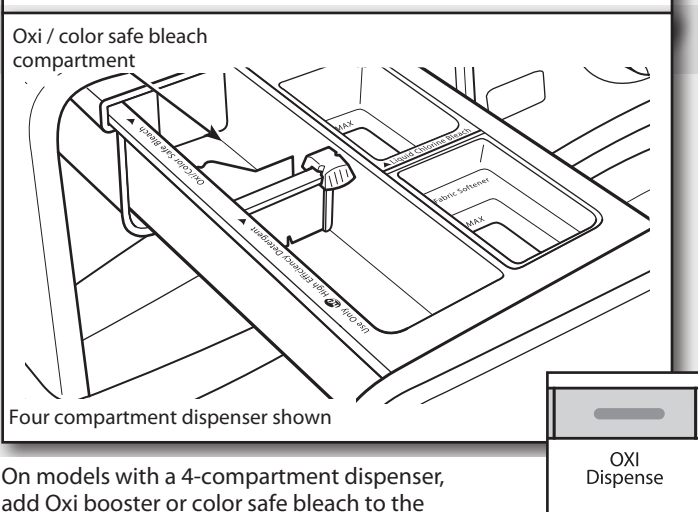

On models with a 4-compartment dispenser, add Oxi booster or color safe bleach to the Oxi compartment. Be sure to select the OXI Dispense option.

- Always follow the manufacturer's recommendations.

When using the Presoak option, 1/3 of the detergent for the load may be placed in the Oxi compartment in place of an Oxi product.

For models without an Oxi compartment:

You may add powdered or liquid Oxi-type boosters or color-safe bleach to the detergent compartment with the same type of detergent, powdered or liquid.

7. Press POWER to turn on washer

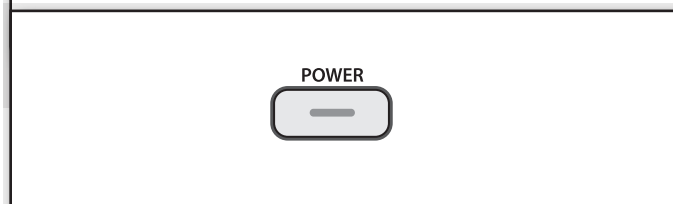

Slowly close the Precision Dispense drawer. Make sure the drawer is closed completely, then press and hold POWER to turn on the washer.

USING THE WASHER (Continued)

8. Select CYCLE

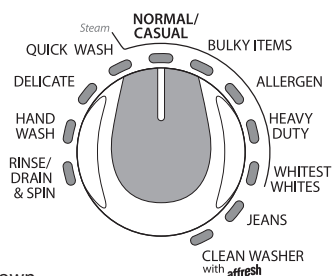

Steam model shown

Turn cycle knob to select your wash cycle. See "Cycle Guide" for details on cycle features. Not all options and settings are available on all cycles.

9. Adjust settings, if desired

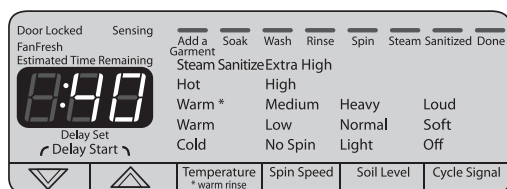

Steam model shown

The display will show the default settings for the selected cycle. If desired, press the button beneath each setting to adjust the Temperature, Soil Level, Spin Speed, and Cycle Signal. Adjusting the Soil Level will change the Estimated Time Remaining. Overloading, unbalanced loads, or excessive suds may also cause the washer to increase the cycle time.

NOTE: Not all settings are available on all cycles. See "Cycle Guide" for available settings.

10. Select any additional options

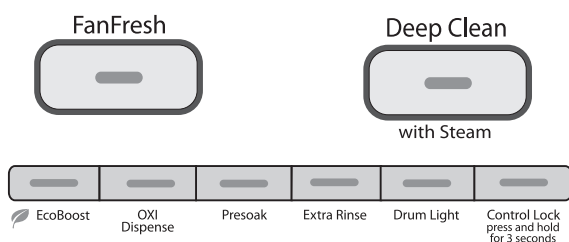

Steam model shown

To add additional options to the cycle, such as the EcoBoost option, Deep Clean/Deep Clean with Steam (on some models), or Presoak, press the button for the desired options to add them to the selected cycle.

NOTE: Not all options are available with all cycles. See "Cycle Guide" for available options.

11. Setting a delayed start

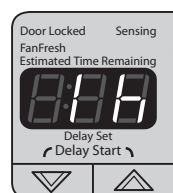

If you do not want to begin a cycle immediately, you may choose the DELAY START option. This will delay the start of the wash cycle by up to 16 hours on models with Steam, and 12 hours on non-Steam models.

To set a delayed Start:

1. Press DELAY START ▲ and ▼ buttons to set the desired delay time.
2. Press START/PAUSE to set the delay. The delay countdown has started when the START/PAUSE light stops blinking.

12. Press and hold START/PAUSE to begin wash cycle



Press and hold the START/PAUSE button to start the wash cycle. To pause a cycle in progress, press the START/PAUSE button once, then press and hold again to continue the cycle. To cancel a cycle, press the POWER button.

Once you press and hold START/PAUSE, you will hear the door lock, unlock, and lock again. The washer door will remain locked during the wash cycle.

Unlocking the door to add garments:

If you need to open the door to add 1 or 2 missed garments, you may do so while the "Add a Garment" light is lit.

Press START/PAUSE once; the door will unlock once the washer movement has stopped. This may take several minutes. Then close door and press START/PAUSE again to restart the cycle.

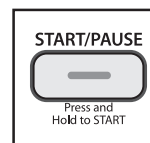

USING THE WASHER (Continued)

Cycle Status Lights

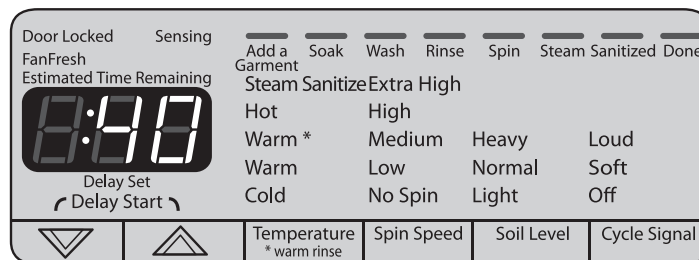

Steam model shown

The Cycle Status Lights show the progress of a cycle. At each stage of the process, you may notice sounds or pauses that are different from traditional washers.

Door Locked

Door Locked will light to indicate that the door is locked and cannot be opened without first pausing or canceling the cycle.

FanFresh™

The FanFresh™ indicator will light when the FanFresh™ option is active. During this time, the washer will occasionally tumble the load while a fan circulates fresh air through the washer.

Add a Garment

When Add a Garment is lit, you may pause the washer, open the door, and add items.

Sensing

When the START/PAUSE button is pressed, the washer will first perform a self-test on the door lock mechanism. You will hear a click, the drum will make a partial turn, and the door will unlock briefly before locking again.

Once the door has locked the second time, the washer will begin tumbling and adding water. This sensing process will continue until the correct amount of water has been added for the load. You may also hear water flowing through the dispenser, adding detergent to the load.

The displayed time may change as the washer goes through the sensing process. This is normal.

Soak

This portion of the cycle allows gentle tumbling for water and detergent to soak into the load for optimal cleaning.

Wash

This is the main portion of the wash cycle. You will see the washer tumble the load. The motor sounds may change at different stages in the cycle. The wash time is determined by the selected cycle and soil level along with your load size.

Rinse

You will hear sounds similar to the wash cycle as the washer rinses and moves the load. If used, liquid chlorine bleach is added in the first rinse. Fabric Softener is added in the last rinse.

Spin

The washer spins the load at increasing speeds for proper water removal, based on the selected cycle and spin speed.

Steam (on some models)

This will light to show that the cycle is using a Steam boost for added cleaning power.

Sanitized

Sanitized will light on cycles with a Sanitize setting once the load has been washed at the proper temperature for the necessary time to meet NSF Sanitization requirements.

Done

Once the cycle is complete, this light will come on. Remove the load promptly for best results.

USING THE WASHER (Continued)

13. Remove garments promptly after cycle is finished

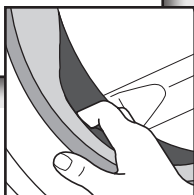
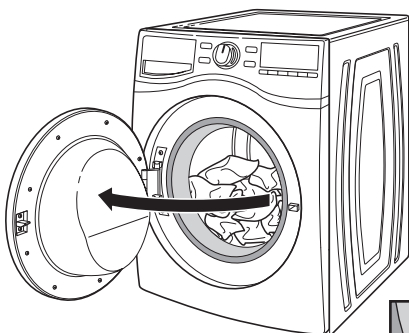

Promptly remove garments after cycle has completed to avoid odor and rusting of metal objects on garments. When unloading garments, pull back the door seal and check for small items between the tub and the basket.

If you will be unable to remove the load promptly, use the FanFresh™ option. If the FanFresh™ option is selected, the washer will automatically activate the fan and tumble the load periodically for up to 16 hours.

NOTE:

- After any wash cycle is completed, the door must be opened and then closed before a new cycle can begin.
- A small amount of water may remain in the dispensers after the wash cycle is complete. This is normal.
- This washer has a tight seal to avoid water leaks. To avoid odors, leave the door open to allow the washer to dry between uses.

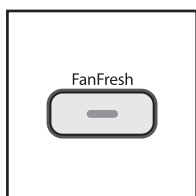

WASHER MAINTENANCE

CLEANING YOUR WASHER

Keep your washer as clean and fresh as your clothes. To keep washer interior odor-free, follow this recommended cleaning procedure at least once a month:

1. Make sure laundry drum is empty.
2. Using recommended AFFRESH washer cleaner, add one tablet to washer basket

OR

If using liquid chlorine bleach, add 1 cup (250 mL) to liquid chlorine bleach dispenser.

IMPORTANT: Do not add detergent to CLEAN WASHER cycle. Do not use more than recommended amount of bleach to avoid damaging product over time.

3. Close washer door.
4. Press POWER.
5. Select CLEAN WASHER with Affresh™ cycle.
6. Press and hold START/PAUSE.

NOTE: The basket will rotate, then the door will unlock, lock again, and then the cycle will continue. The washer will add some water, and the basket will rotate while the washer runs a short sensing cycle. This will take approximately 3 minutes.

7. The cycle will determine whether clothing or other items are in the washer. If no items are detected in the washer, it will proceed to Step 8.

If any items are detected in the washer, "rL" will be displayed, and the WASH and CONTROL LOCK lights will light. The door will unlock. Open and remove any garments in the wash drum. Press POWER to cancel the error message. Then repeat steps 3–6 to start the cycle again.

8. Once the cycle has started, allow it to finish. If START, PAUSE or POWER is pressed before the cycle is complete, "Int" (Interrupted) will appear in the display. It may take up to 10 minutes for the door to unlock.
9. After the cycle has ended, leave the door open slightly, to allow for better ventilation and drying of washer interior.

To clean exterior:

1. Use a soft, damp cloth or sponge to wipe up any spills.
2. Use mild soap and water if needed.

IMPORTANT: To avoid damaging washer finish, do not use abrasive products.

CLEANING THE DOOR SEAL

1. Open the washer door and remove any clothing or items from the washer.
2. Inspect the gray colored seal between the door opening and the basket for stained areas. Pull back the seal to inspect all areas under the seal and to check for foreign objects.

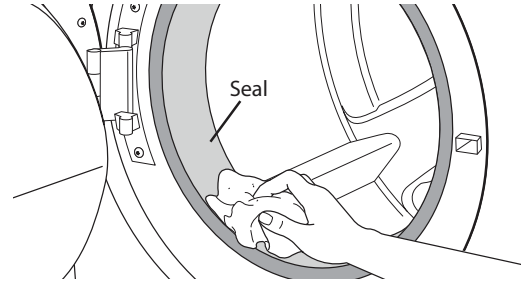

3. If stained areas are found, wipe down these areas of the seal, using the procedure that follows.
 - a) Mix a dilute solution, using 3/4 cup (177 mL) of liquid chlorine bleach, and 1 gal. (3.8 L) of warm tap water.
 - b) Wipe the seal area with the dilute solution, using a damp cloth.
 - c) Let stand 5 minutes.
 - d) Wipe down area thoroughly with a dry cloth and let the washer interior air dry with door open.

IMPORTANT: Wear rubber gloves when cleaning for prolonged periods. Refer to the bleach manufacturer's instructions for proper use.

WASHER MAINTENANCE (Continued)

CLEANING THE DISPENSER

You may find laundry product residue leftover in your dispenser compartments. To remove residue, follow this recommended cleaning procedure:

1. Pull dispenser drawer out until it stops.
2. Press down on the release tab and pull straight out to remove the dispenser.

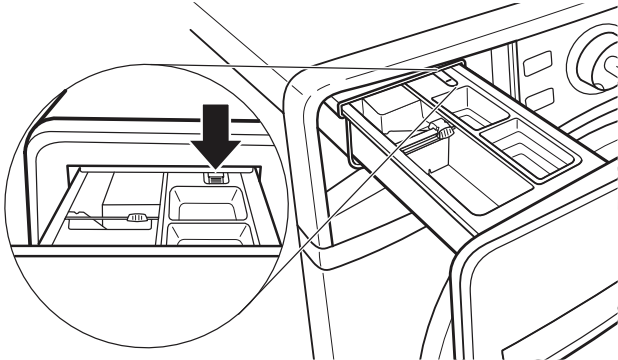

3. Lift off cover panel by pulling straight up.

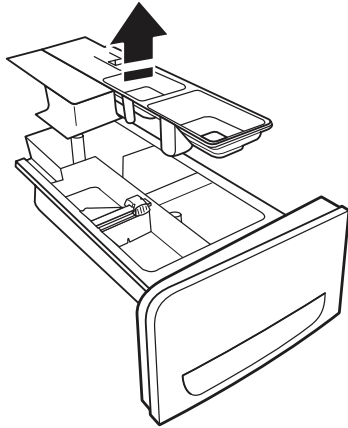

4. Wash dispenser and cover panel in warm, soapy water, using a mild detergent.
5. Rinse with warm water.
6. Air dry or wipe with a clean towel, slide cover panel back onto posts on dispenser.
7. Align edges of dispenser with guides in washer, then slide dispenser back into slot.

IMPORTANT: Dispenser is not dishwasher safe.

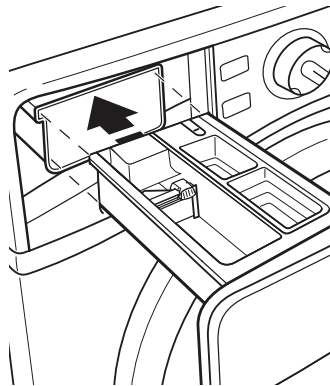

NON-USE AND VACATION CARE

Operate your washer only when you are home. If moving, or not using your washer for a period of time, follow these steps:

1. Unplug or disconnect power to washer.
2. Turn off water supply to washer to avoid flooding due to water pressure surges.

WINTER STORAGE CARE

IMPORTANT: To avoid damage, install and store washer where it will not freeze. Because some water may stay in hoses, freezing can damage washer. If storing or moving during freezing weather, winterize your washer.

To winterize washer:

1. Shut off both water faucets, disconnect and drain water inlet hoses.
2. Put 1 qt. (1 L) of R.V.-type antifreeze in basket and run washer on RINSE AND SPIN cycle for about 30 seconds to mix antifreeze and remaining water.
3. Unplug washer or disconnect power.

IMPORTANT: To reduce risk of hose failure, replace inlet hoses every five years and periodically inspect for kinks, cuts, wear or water leaks.

HELPFUL TIP: When replacing your inlet hoses, mark replacement date on label with a permanent marker.

TRANSPORTING YOUR WASHER

1. Shut off both water faucets. Disconnect and drain water inlet hoses.
2. If washer will be moved during freezing weather, follow WINTER STORAGE CARE directions before moving.
3. Disconnect drain hose from drain system and from back of washer.
4. Unplug power cord.
5. Place inlet hoses and drain hose inside washer basket.
6. Bundle power cord with a rubber band or cable tie to keep it from hanging onto the ground.

IMPORTANT: Call for service to install new transport bolts. Do not reuse transport bolts. Washer must be transported in the upright position. To avoid structural damage to your washer, it must be properly set up for relocation by a certified technician.

WASHER MAINTENANCE (Continued)

⚠ WARNING



Electrical Shock Hazard

Plug into a grounded 3 prong outlet.

Do not remove ground prong.

Do not use an adapter.

Do not use an extension cord.

Failure to follow these instructions can result in death, fire, or electrical shock.

REINSTALLING/USING WASHER AGAIN

To reinstall washer after non-use, vacation, winter storage, or moving:

1. Refer to Installation Instructions to locate, level, and connect washer.
2. Before using again, run washer through the following recommended procedure:

To use washer again:

1. Flush water pipes and hoses. Reconnect water inlet hoses. Turn on both water faucets.
2. Plug in washer or reconnect power.
3. Run washer through BULKY ITEMS cycle to clean washer and remove antifreeze, if used. Use only HE detergent. Use half the manufacturer's recommended amount for a medium-size load.

TROUBLESHOOTING

First try the solutions suggested here or visit our website at www.whirlpool.com/help for assistance and to possibly avoid a service call.

If you experience	Possible Causes	Solution
Vibration or Off-Balance		
Vibration, rocking, or "walking"	Feet may not be in contact with the floor and locked.	Front and rear feet must be in firm contact with floor, and washer must be level to operate properly. Jam nuts must be tight against the bottom of the cabinet.
	Washer may not be level.	Check floor for flexing or sagging. If flooring is uneven, a 3/4" (19 mm) piece of plywood under your washer will reduce sound.
		See "Level the Washer" in Installation Instructions.
	Load could be unbalanced or too large.	Avoid tightly packing the load. Avoid washing single items. Balance a single item such as a rug or jeans jacket with a few extra items.
		Use Bulky Item cycle for oversized, non-absorbent items such as comforters or poly-filled jackets. Other items are not appropriate for Bulky Items cycle. See "Cycle Guide".
		Item or load not suitable for selected cycle. See "Cycle Guide" and "Using Your Washer" in this Use and Care Guide.
Noises		
Clicking or metallic noises	Door locking or unlocking.	The door will lock unlock and lock again. You will hear three clicks after pushing start. This is normal.
	Objects caught in washer drain system.	Empty pockets before washing. Loose items such as coins could fall between basket and tub or may block pump. It may be necessary to call for service to remove items.
		It is normal to hear metal items on clothing such as metal snaps, buckles, or zippers touch against the stainless steel basket.
Gurgling or humming	Washer may be draining water.	It is normal to hear the pump making a humming sound with periodic gurgling or surging as final amounts of water are removed during the spin/drain cycles.
Water Leaks		
Check the following for proper installation:	Fill hoses not attached tightly.	Tighten fill-hose connection.
	Fill hose washers.	Are all four fill hose flat washers properly seated?
	Drain hose connection.	Check that the drain hose is properly secured to drainpipe or laundry tub.
	Check household plumbing for leaks or clogged sink or drain.	Water can backup out of a clogged sink or drainpipe. Check all household plumbing for leaks (laundry tubs, drain pipe, water pipes, and faucets.)
Water or suds leaking from door or rear of cabinet	Not using HE detergent or using too much HE detergent.	Only use HE detergent. Suds from regular detergents can cause leaking from the door or rear of cabinet. Always measure detergent and follow manufacturer's directions based on your load requirements.
	Residue on door glass.	Periodically clean the the underside of the glass window to avoid potential leaks.
Washer not performing as expected		
Load not completely covered in water.	Water level not visible on door or does not cover clothes.	This is normal for an HE front load washer. The washer senses load sizes and adds the correct amount of water for optimal cleaning.

TROUBLESHOOTING (continued)

⚠ WARNING



Electrical Shock Hazard

Plug into a grounded 3 prong outlet.

Do not remove ground prong.

Do not use an adapter.

Do not use an extension cord.

Failure to follow these instructions can result in death, fire, or electrical shock.

First try the solutions suggested here or visit our website at www.whirlpool.com/help for assistance and to possibly avoid a service call.

If you experience	Possible Causes	Solution
Washer not performing as expected (cont.)		
Washer won't run or fill, washer stops working	Check for proper water supply.	Both hoses must be attached and have water flowing to inlet valve.
		Both Hot and Cold water faucets must be turned on.
		Check that inlet valve screens have not become clogged.
		Check for any kinks in inlet hoses, which can restrict water flow.
	Check proper electrical supply.	Plug power cord into a grounded 3 prong outlet.
		Do not use an extension cord.
		Ensure there is power to outlet.
		Reset a tripped circuit breaker. Replace any blown fuses. NOTE: If problems continue, contact an electrician.
	Normal washer operation.	Door must be completely closed and latched for washer to run.
		Washer will pause during certain phases of cycle. Do not interrupt cycle.
		Washer may be stopped to reduce suds.
	Washer not loaded as recommended.	Remove several items, rearrange load evenly in drum. Close door and press START / PAUSE.
		Do not add more than 1 or 2 additional items after cycle has started to avoid overloading or unbalancing.
		Do not add more water to the washer.
Not using HE detergent or using too much HE detergent.	Only use HE detergent. Suds from regular detergents can slow or stop the washer. Always measure detergent and following manufacturers directions based on your load requirements.	
	To remove suds, cancel cycle. Select RINSE/DRAIN & SPIN. Press START/PAUSE. Do not add more detergent.	
Door not opened between cycles.	After any wash cycle is completed, the door must be opened and then closed before a new cycle can begin.	

TROUBLESHOOTING (continued)

First try the solutions suggested here or visit our website at www.whirlpool.com/help for assistance and to possibly avoid a service call.

If you experience	Possible causes	Solution
Washer not performing as expected (cont.)		
Washer not draining/spinning, loads are still wet	Empty pockets and use garment bags for small items.	Small items may have been caught in pump.
	Using cycles with a lower spin speed.	Cycles with lower spin speeds remove less water than cycles with high spin speeds. Use the recommended cycle/speed spin for your garment.
	Washer not loaded as recommended.	A tightly packed or unbalanced load may not allow the washer to spin correctly, leaving the load wetter than normal. See "Cycle Guide" for Load Size Recommendation for each cycle.
	The load may be out of balance.	Avoid washing single items. Balance a single item such as a rug or jeans jacket with a few extra items.
	Check plumbing for correct drain hose installation. Drain hose extends into standpipe farther than 4.5" (114 mm).	Check drain hose for proper installation. Use drain hose form and securely attach to drainpipe or tub. Do not tape over drain opening. Lower drain hose if the end is higher than 96" (2.4 m) above the floor. Remove any clogs from drain hose.
	Not using HE detergent or using too much HE detergent.	Use only HE detergent. Suds from regular detergent or using too much detergent can slow or stop draining or spinning. Always measure and follow manufacturer's directions for your load. To remove extra suds, Select RINSE/DRAIN & SPIN. Do not add detergent.
Door locked at end of wash cycle.	Water remaining in washer after cycle.	Select RINSE/ DRAIN & SPIN to remove any water remaining in the washer. The washer door will unlock at the end of the drain.
Incorrect or wrong wash or rinse temperatures	Check for proper water supply.	Are hot and cold inlet hoses reversed?
		Both hoses must be attached to both washer and faucet, and have both hot and cold water flowing to inlet valve.
		Check that inlet valve screens are not clogged.
		Remove any kinks in hoses.
Warm* selection not available.	Not all settings and options are available for all cycles.	See the "Cycle Guide" for the available settings and options for each cycle.
Load not rinsed	Check for proper water supply.	Are hot and cold inlet hoses reversed?
		Both hoses must be attached and have water flowing to the inlet valve.
		Both hot and cold water faucets must be on.
		Inlet valve screens on washer may be clogged.
		Remove any kinks in the inlet hose.
	Not using HE detergent or using too much HE detergent.	The suds from regular detergent can cause the washer to operate incorrectly.
		Use only HE detergent. Always measure detergent and follow manufacture's directions based on load size and soil level.
	Washer not loaded as recommended.	Avoid tightly packing the washer. The washer will not rinse well if tightly packed. Load with dry items only. See the "Cycle Guide" for load size recommendations for each cycle.
		Use cycle designed for the fabrics being washed.
Add only 1 or 2 garments after washer has started.		

TROUBLESHOOTING (continued)

First try the solutions suggested here or visit our website at www.whirlpool.com/help for assistance and to possibly avoid a service call.

If you experience	Possible Causes	Solution
Washer not performing as expected (cont.)		
Load is tangling	Washer not loaded as recommended.	Add load loosely. Items need to move freely reduce wrinkling and tangling. See the "Cycle Guide" for load size recommendations for each cycle.
		Reduce tangling by mixing types of load items. Use the recommended cycle for the type of garments being washed.
	Wash action and/or spin speed too fast for load.	Select a slower spin speed. Note that items will be wetter than when using a higher speed spin.
Not cleaning or removing stains	Washer not loaded as recommended.	Add load loosely. Items need to move freely for best cleaning. See the "Cycle Guide" for load size recommendations for each cycle.
		Add only 1 or 2 garments after washer has started.
	Not using HE detergent or using too much HE detergent.	Use only HE detergent. Always measure detergent and follow manufacturer's directions based on load size and soil level.
	Hard water or high level of iron (rust) in water.	You may need to install a water softener and/or iron filter.
	Fabric softener dispensing ball used.	Dispensing balls will not operate correctly with this washer. Add liquid fabric softener to the fabric softener compartment.
	Powdered detergent used for low-speed cycle.	Consider using liquid detergent.
	Not using correct cycle for fabric type.	Use a higher soil level cycle option and warmer wash temperature to improve cleaning.
		If using Quick Wash cycle, wash only a few items.
		Use Whitest Whites and Heavy Duty cycle for tough cleaning.
		Add an extra rinse for heavily soiled loads.
	Not using dispensers.	Use dispensers to avoid chlorine bleach and fabric softener staining.
Load dispensers before starting a cycle.		
Avoid overfilling.		
Do not add products directly to load.		
Not washing like colors together.	Wash like colors together and remove promptly after the cycle is complete to avoid dye transfer.	
Not enough detergent used, or hard water.	Use more detergent for washing heavy soils in cold or hard water.	
Odors	Monthly maintenance not done as recommended.	Run the Clean Washer cycle with AFFRESH® monthly. See "Cleaning Your Washer" in Washer Maintenance .
		Unload washer as soon as cycle is complete. Use the FanFresh option if load cannot be removed immediately after the wash is complete.
	Not using HE detergent or using too much HE detergent.	Use only HE detergent. Be sure to measure correctly. Always follow the manufacturer's directions.
		See "Cleaning your Washer" section.
Door not left open after use.	This washer has a tight seal to avoid water leaks. To avoid odors, leave the door open to allow the washer to dry between uses.	

TROUBLESHOOTING (continued)

First try the solutions suggested here or visit our website at www.whirlpool.com/help for assistance and to possibly avoid a service call.

If you experience	Possible Causes	Solution
Washer not performing as expected (cont.)		
Fabric Damage	Sharp items were in pockets during wash cycle.	Empty pockets, zip zippers, and snap or hook fasteners before washing to avoid snags and tears.
	Strings and straps could have tangled.	Tie all strings and straps before starting wash load.
	Items may have been damaged before washing.	Mend rips and broken threads in seams before washing.
	Fabric damage can occur if washer is tightly packed.	Avoid tightly packing the washer. Load with dry items only.
		Use cycle designed for the fabrics being washed.
		Add only 1 or 2 garments after washer is started.
Liquid chlorine bleach may have been added incorrectly.	Do not pour liquid chlorine bleach directly onto load. Wipe up bleach spills.	
	Undiluted bleach will damage fabrics. Do not use more than recommended by manufacturer.	
Gray whites, dingy colors	Load not sorted properly.	The transfer of dye can occur when mixing whites and colors in a load. Sort dark clothes from whites and lights.
	Wash temperatures too low.	Use hot or warm washes if safe for the load. Make sure your hot water system is adequate to provide a hot water wash.
	Not enough detergent used, or hard water.	Use more detergent for washing heavy soils in cold or hard water.
Incorrect dispenser operation	Clogged dispensers or laundry products dispensing too soon.	Do not overfill dispenser. Overfilling causes immediate dispensing.
		Load dispensers before starting a cycle.
		Homes with low water pressure may result in residual powder in the dispenser. To avoid, select a warmer wash temperature if possible, depending on your load.
	Liquid chlorine bleach not used in bleach compartment.	Use only liquid chlorine bleach in the bleach compartment.
	Oxi Dispense option (on some models) not selected.	You may use powdered or liquid laundry boosters in the Oxi compartment (on some models). Always select the Oxi Dispense option for proper flushing of Oxi products from dispenser. Leftover powder may be wiped out by hand, if needed. Otherwise, select Oxi Dispense option with the next cycle to rinse out dispenser.
Water in dispenser after cycle has finished.	It is normal for small amounts of water to remain in dispenser at the end of the cycle.	

TROUBLESHOOTING (continued)

First try the solutions suggested here or visit our website at www.whirlpool.com/help for assistance and to possibly avoid a service call.

If you experience	Possible Causes	Solution
Error Code Appears in Display		
Once any possible issues are corrected, press START/PAUSE once to clear the code. Then press START/PAUSE again to restart washer. If code appears again, call for service.		
Sud (Excess suds) appears in display	Excessive suds in washer. Washer is running a suds reduction routine.	Allow the machine to continue. Use only HE detergent. Always measure detergent, and base detergent quantity on load size. Follow detergent manufacturer's instructions. If the dial is flashing, reselect your desired cycle using a cold wash temperature, and press START/PAUSE. Do not add detergent.
F8E1 (water supply error) appears in display	Check for proper water supply.	Are hot and cold inlet hoses reversed?
		Both hoses must be attached and have water flowing to the inlet valve.
		Both hot and cold water faucets must be on.
		Inlet valve screens on washer may be clogged.
		Remove any kinks in the inlet hose.
		Press START/PAUSE once to clear the code. Then press START/PAUSE again to restart washer. If code appears again, call for service.
F9E1 (drain pump system error) appears in display	Check plumbing for correct drain hose installation. Drain hose extends into standpipe farther than 4.5" (114 mm).	Check drain hose for proper installation.
		Make sure the drain hose is not kinked, pinched, or blocked.
		Remove any clogs from drain hose.
		Use drain hose form and securely attach to drainpipe or tub.
		Lower drain hose if the end is higher than 96" (2.4 m) above the floor.
F5E2 (door will not lock) appears in display	Washer door not locking.	Press POWER to cancel the cycle. Make sure the door is closed completely and latching. Check for items in the washer drum that may be keeping the door from closing completely.
F7E1 (motor drive error) appears in display	Motor is having difficulty turning the drum.	Washer is overloaded. Remove some items. See "Cycle Guide" for load size recommendations. Make sure that all shipping materials have been removed. See the Installation Instructions.
"rl" (remove load) appears in display	Load detected in drum during Clean Washer cycle.	Remove items from drum and restart Clean Washer cycle.
F5E1 code appears in display	Door has not been opened and closed for at least 3 cycles.	This code may appear when the washer is first turned on. Open and close the door to clear the display.
F#E# code other than as described above appears in display	System error code.	Press POWER once to clear the code. Then press POWER again to restart washer. If code appears again, call for service.

COMPONENT ACCESS

This section instructs you on how to service each component inside this Front-Loading Automatic Washer. The components and their locations are shown below.

COMPONENT LOCATIONS

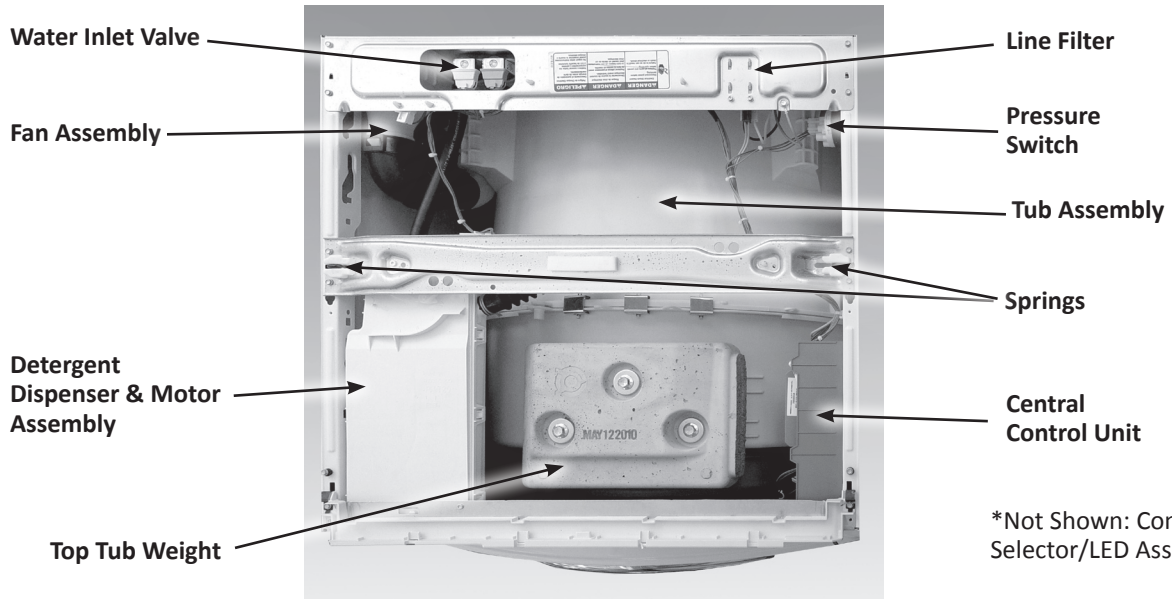

***Top View
(top panel removed)**

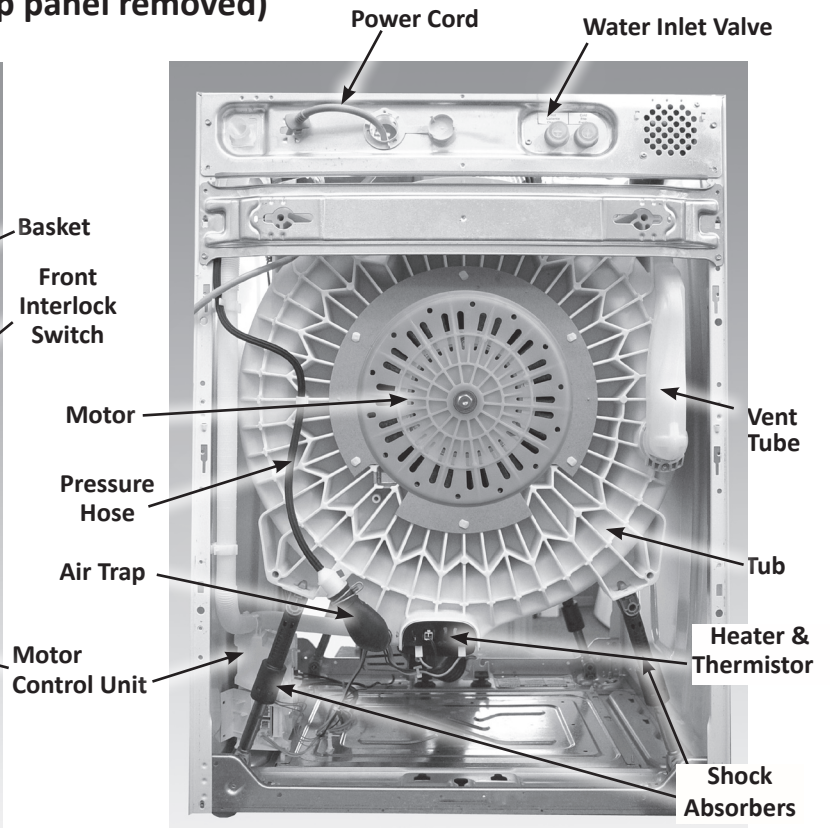
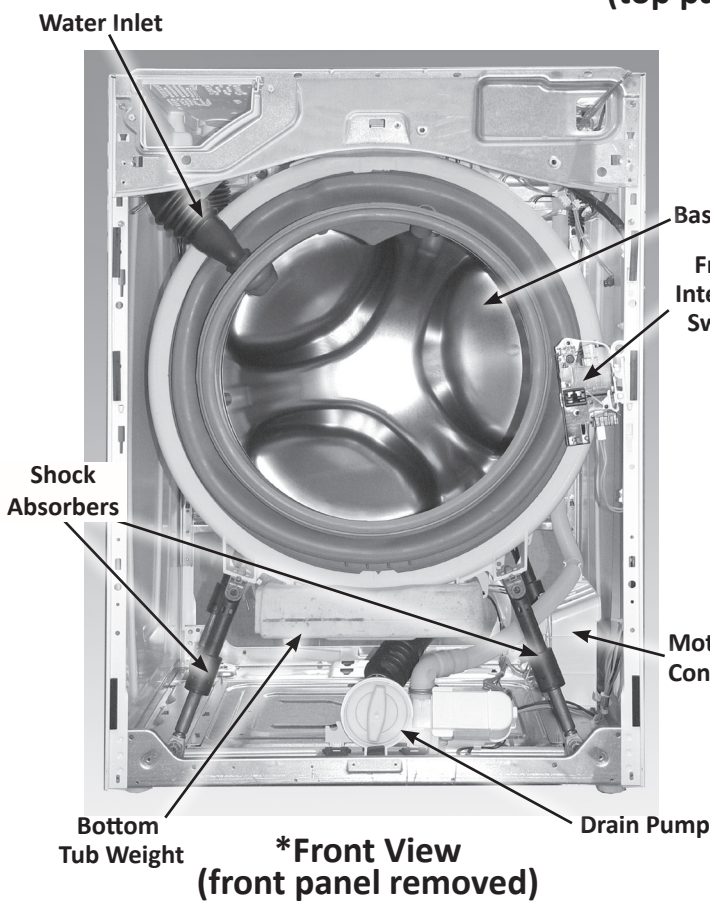

REMOVING THE DISPENSER DRAWER, TOP AND CONSOLE ASSEMBLY

⚠ WARNING



Electrical Shock Hazard
Disconnect power before servicing.
Replace all parts and panels before operating.
Failure to do so can result in death or electrical shock.

1. Unplug washer or disconnect power.
2. Turn off the water supply to the washer.
3. To Remove the dispenser drawer:
 - a) pull the drawer all the way out and depress the tab labeled "push" to remove drawer.

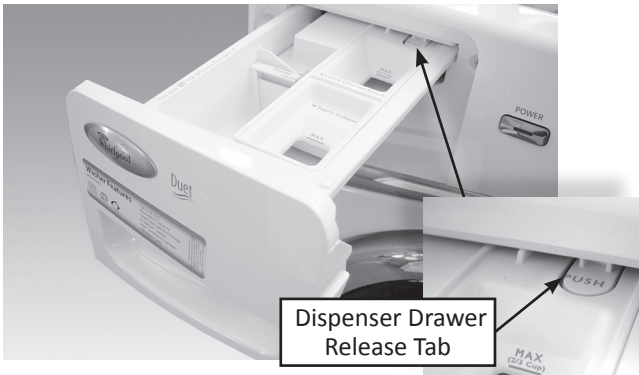

4. To remove the top:
 - a) Remove the three 1/4" screws from the rear top cover of the washer.

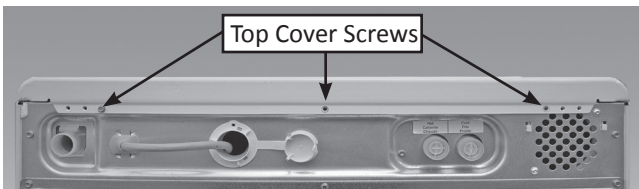

- b) Pull back on the top.

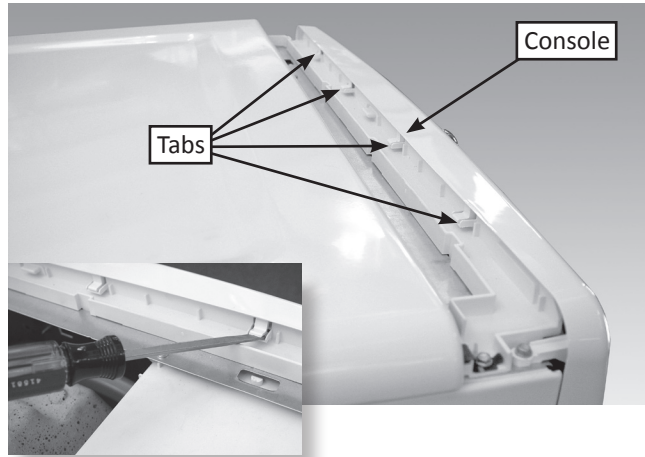

5. To remove the console:
 - a) Remove the top.
 - b) Remove 2 screws at both ends on the top of the console.

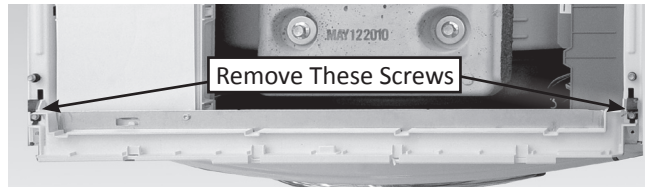

View is top front

- c) Remove 2 T25 Torx head on either side of drawer opening.

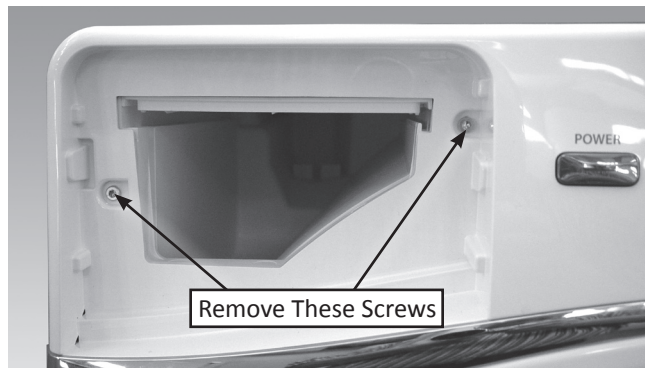

- d) Lift the top edge of the console and unhook it from the holder tabs.

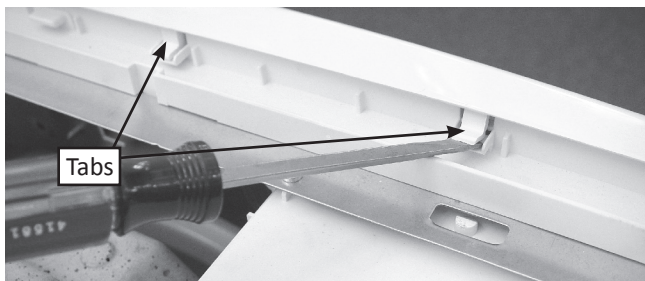

REMOVING THE CONSOLE AND THE SELECTOR/LED ASSEMBLY (continued)

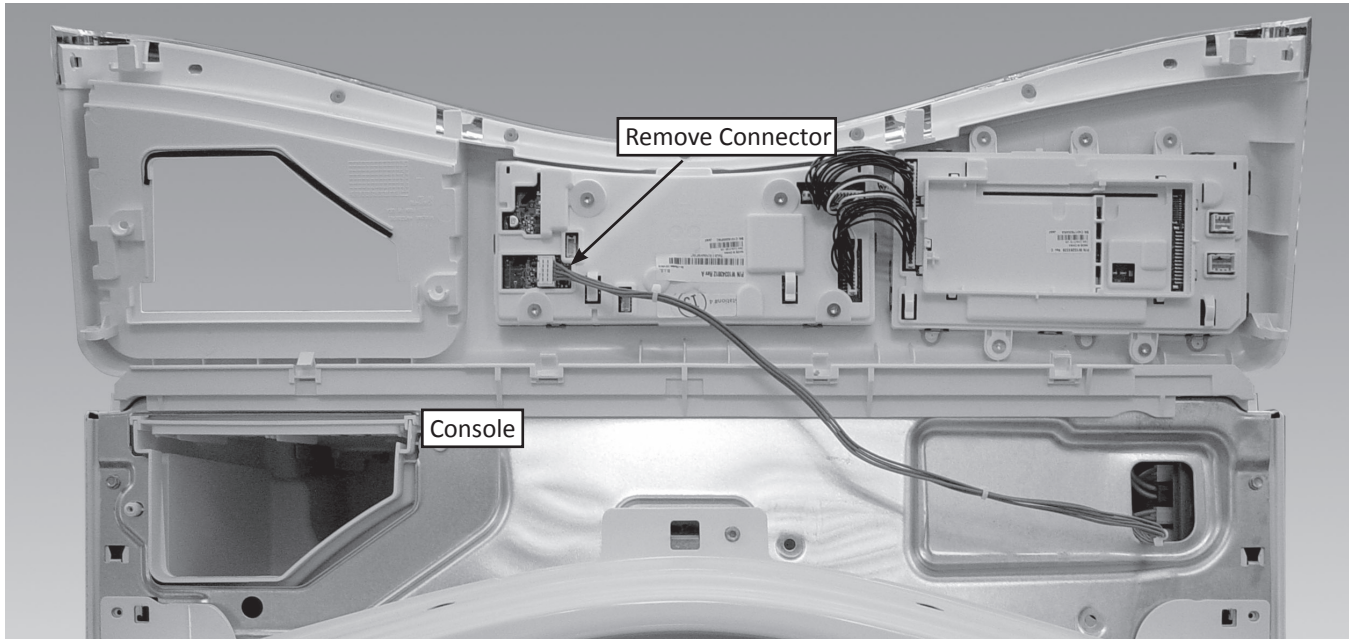

e) Remove the connector.



Console Front

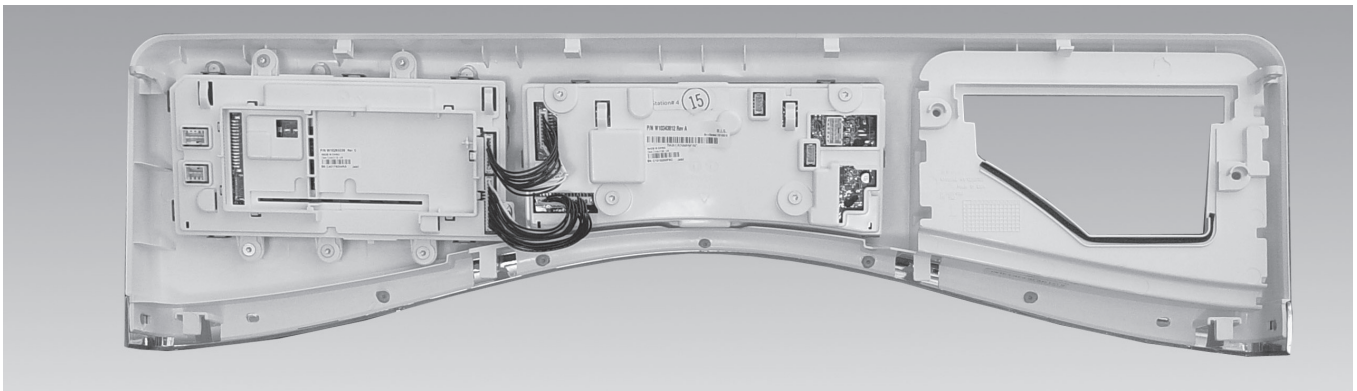

Console Back

REMOVING THE CENTRAL CONTROL UNIT

⚠️ WARNING



Electrical Shock Hazard

Disconnect power before servicing.
Replace all parts and panels before operating.

Failure to do so can result in death or electrical shock.

1. Unplug washer or disconnect power.
2. Turn off the water supply to the washer.
3. Remove the top cover from the washer, see "REMOVING THE DISPENSER DRAWER, TOP AND CONSOLE ASSEMBLY" for procedure.

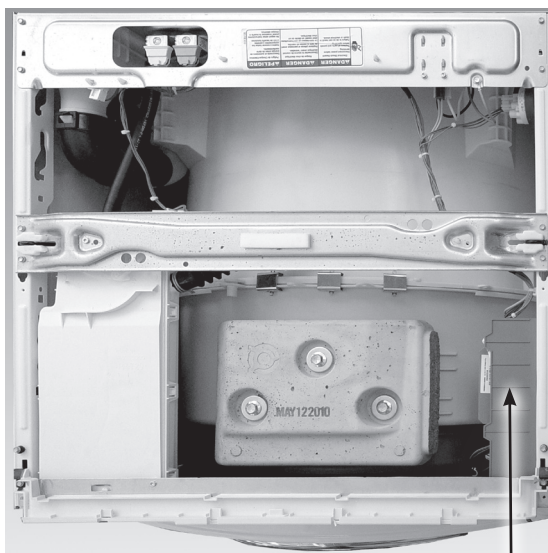

Central Control Unit

4. Pull the wire connectors off the edges of the central control unit circuit board (see figure 1). When removing an edge connector, first loosen the locking tab on the connector with a small screwdriver blade to release it.
5. Slide the hooked ends of the two wire clamps off the locking tabs, and remove the wires from the clamps.

Central Control Unit Connectors (21)

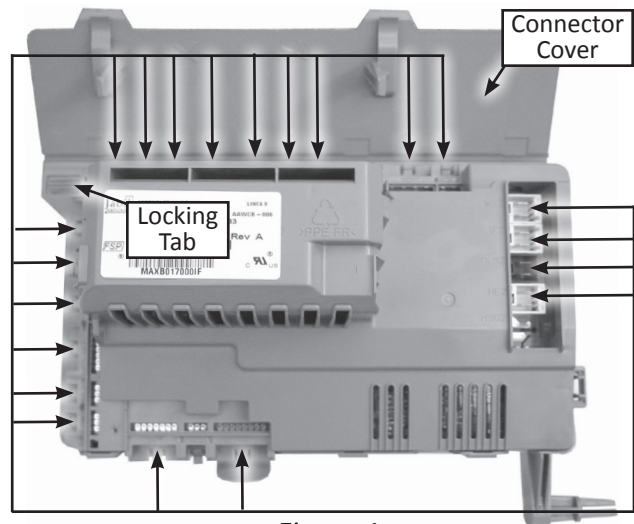
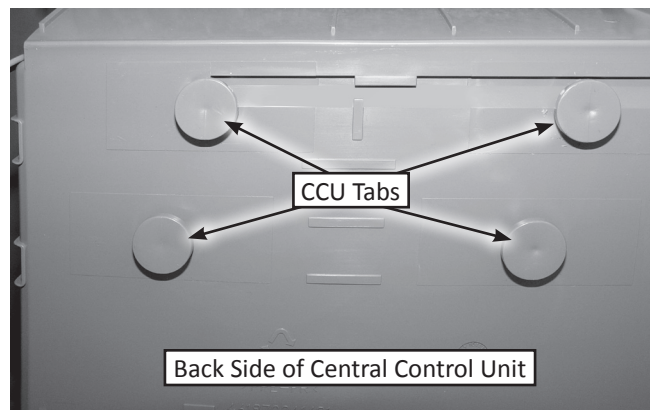
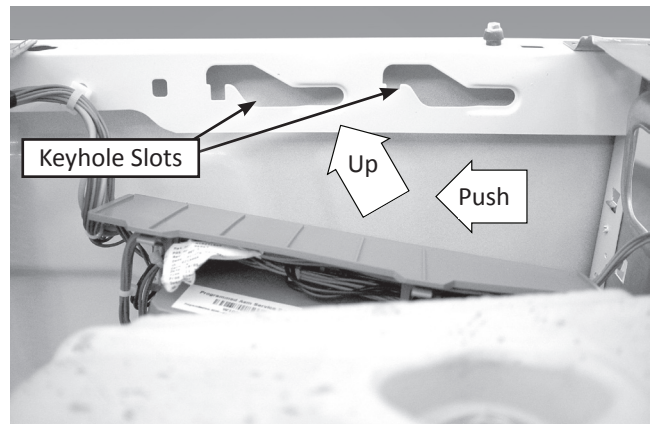

Figure 1

6. Lift up on the locking tab, and push the central control unit (CCU) toward the rear of the washer and up as far as it will go, and remove the CCU tabs from the keyhole slots in the chassis.



Back Side of Central Control Unit

REMOVING THE CENTRAL CONTROL UNIT (continued)

REASSEMBLY NOTE: The photo shows the connector callouts for the central control unit.

Make sure that all connectors are firmly seated onto the circuit board, and that they lock securely into place.

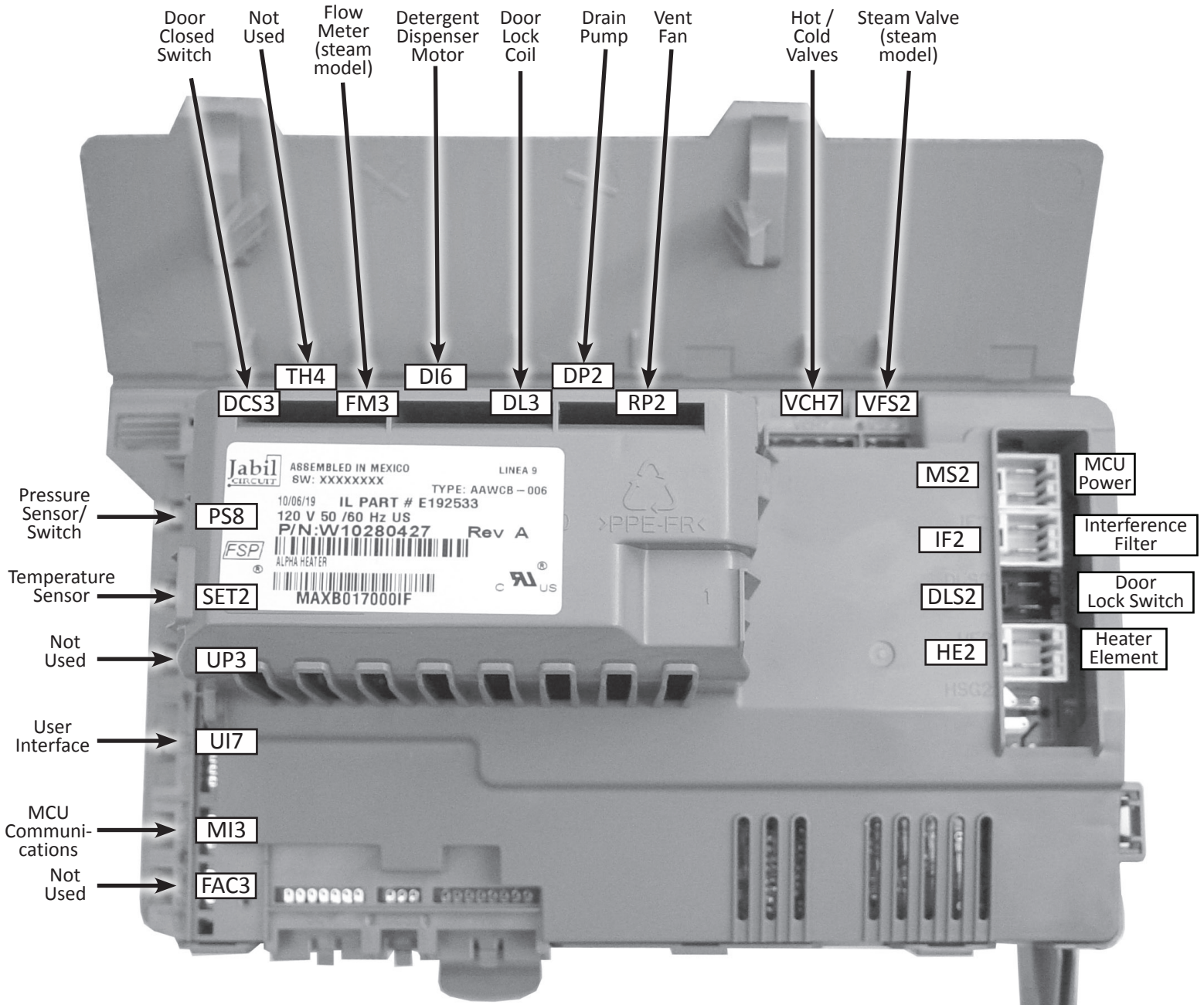

REMOVING THE WATER INLET VALVE

⚠ WARNING



Electrical Shock Hazard
Disconnect power before servicing.
Replace all parts and panels before operating.
Failure to do so can result in death or electrical shock.

1. Unplug washer or disconnect power.
2. Turn off the water supply to the washer.
3. Remove the water hoses from the hot and cold water inlet valve.
4. Remove the top cover (see "REMOVING THE DISPENSER DRAWER, TOP AND CONSOLE ASSEMBLY" for the procedure).

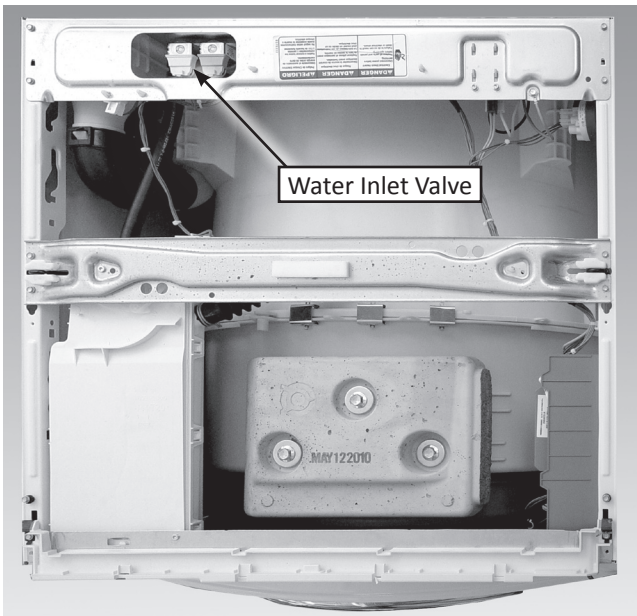

5. Lift the locking tabs with a small-blade screwdriver and pull the wire connectors out of the hot and cold water inlet valve solenoid terminal holders.
6. Loosen the clamp, and pull the water inlet hose off the water valve.

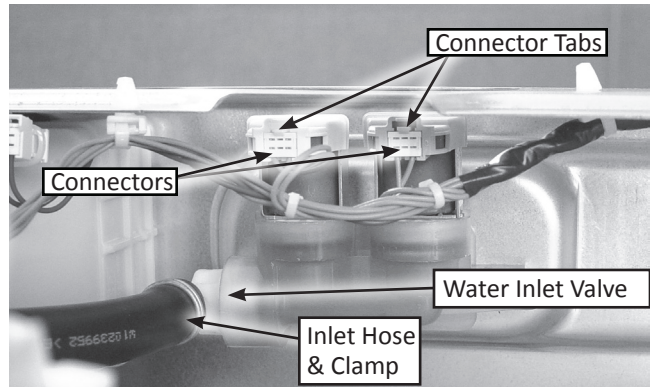

7. At the rear of the washer, remove the screw from the water inlet valve. Slide the valve to the right, and push it into the washer off the rear panel.

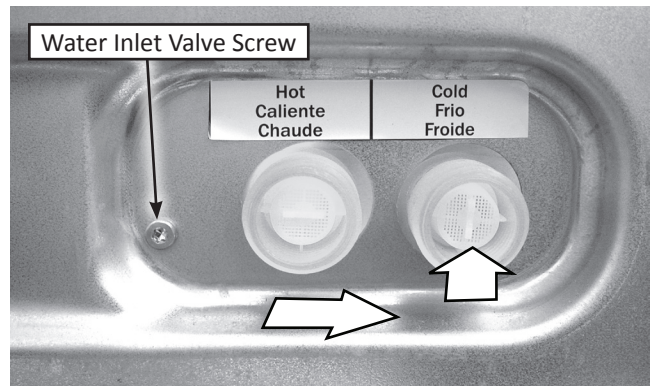

REMOVING THE PRESSURE SWITCH

⚠ WARNING



Electrical Shock Hazard
Disconnect power before servicing.
Replace all parts and panels before operating.
Failure to do so can result in death or electrical shock.

1. Unplug washer or disconnect power.
2. Turn off the water supply to the washer.
3. Remove the top cover from the washer (REMOVING THE DISPENSER DRAWER, TOP AND CONSOLE ASSEMBLY for the procedure).

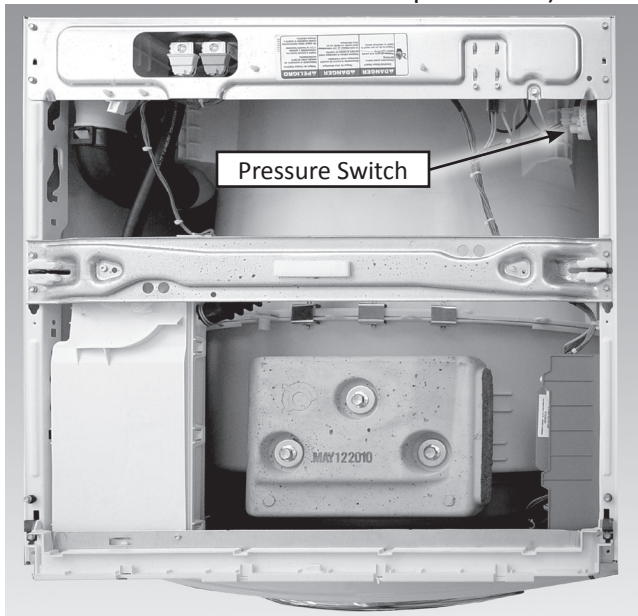

4. Press and release the two wire connector locking arms and pull the connector off the pressure switch.
5. Pull the pressure hose off the pressure switch fitting.

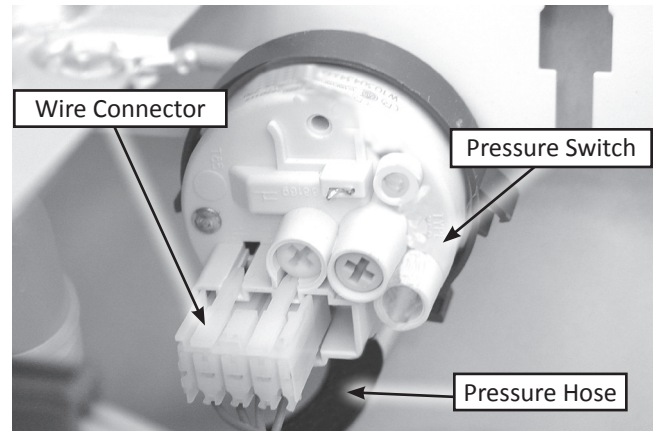

6. Turn the pressure switch 90° in either direction, and align the key on the switch with the slot in the chassis, then remove the switch from the washer.

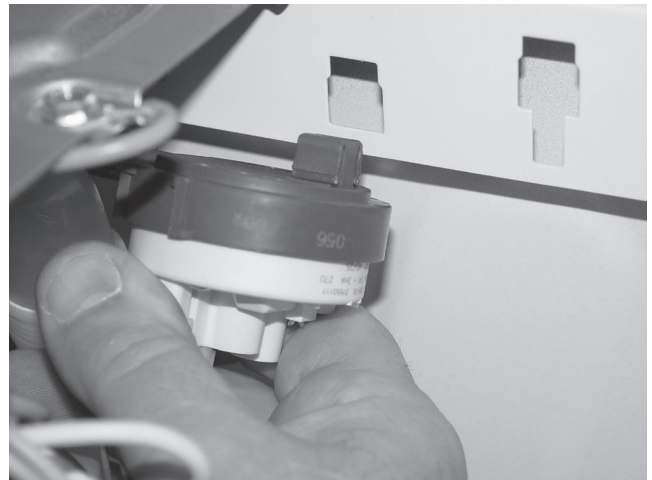

REMOVING THE LINE FILTER & POWER SUPPLY CORD

⚠ WARNING



Electrical Shock Hazard

**Disconnect power before servicing.
Replace all parts and panels before
operating.**

**Failure to do so can result in death or
electrical shock.**

1. Unplug washer or disconnect power.
2. Turn off the water supply to the washer.
3. Remove the top cover from the washer ("REMOVING THE DISPENSER DRAWER, TOP AND CONSOLE ASSEMBLY" for the procedure).

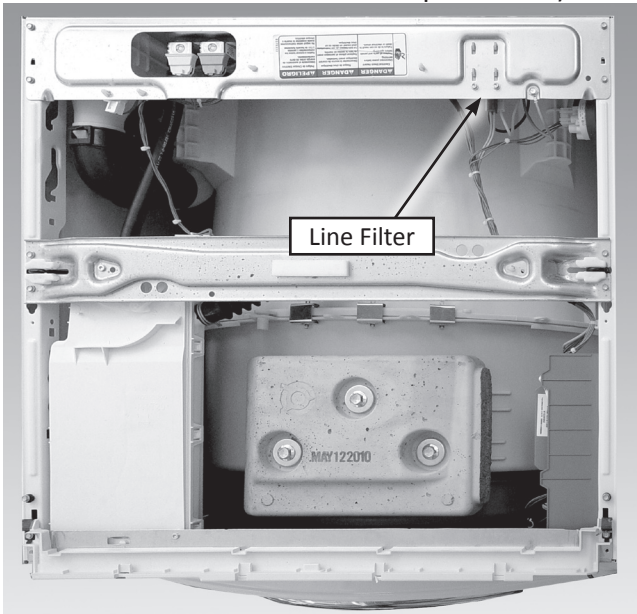

4. **To remove the line filter:**
 - a) Remove 2 T-20 Torx/hex-head screws from the line filter.
 - b) Position the line filter so that the four tabs are aligned with the chassis slots and remove the filter from the washer.

- c) Disconnect the three wire connectors from the line filter. NOTE: Press and release the locking tabs on the 2-wire connector to disconnect it from the filter.

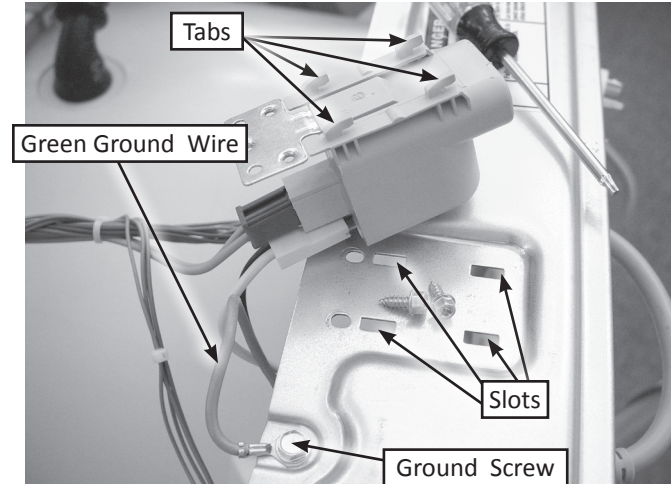

5. **To remove the power supply cord:**

- a) Remove the screw from the green ground wire.
- b) Pull the connectors with the white and black wires from the line filter terminals.
- c) Pull the washer away from the wall far enough to access the power supply cord on the rear panel.
- d) Use a pair of pliers and turn the strain relief on the power supply cord 90° in either direction. Align the strain relief key with the slot in the rear panel, and remove the cord from the washer.

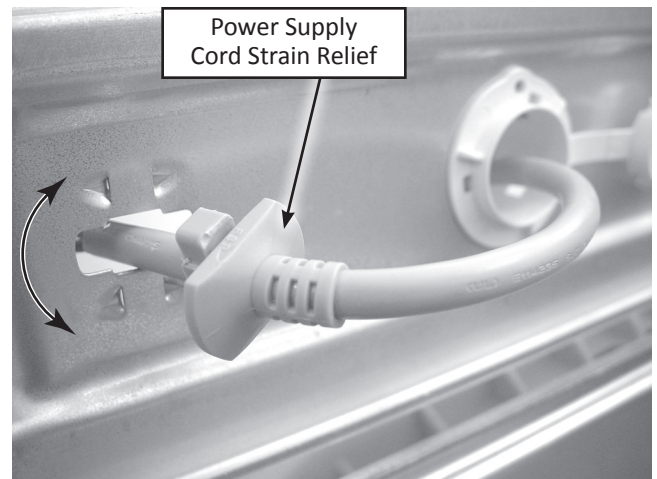

REMOVING THE DETERGENT DISPENSER ASSEMBLY

⚠ WARNING



Electrical Shock Hazard
Disconnect power before servicing.
Replace all parts and panels before operating.
Failure to do so can result in death or electrical shock.

1. Unplug washer or disconnect power.
2. Turn off the water supply to the washer.
3. Remove the top cover from the washer.
See "REMOVING THE DISPENSER DRAWER, TOP AND CONSOLE ASSEMBLY" for the procedure).

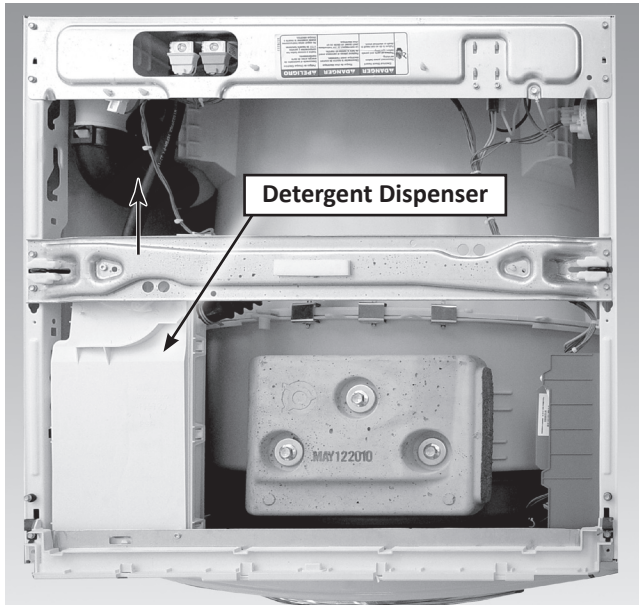

4. Remove the console from the washer (see step 5 "REMOVING THE DISPENSER DRAWER, TOP AND CONSOLE ASSEMBLY" for the procedure).
5. Loosen the clamp and remove the water supply tube from the detergent dispenser.

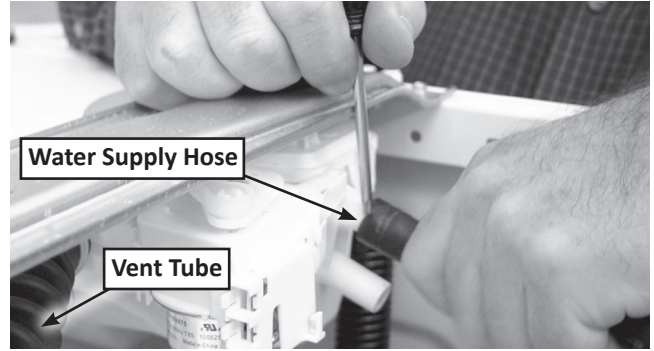

6. Loosen the clamp and remove the tub-to-dispenser vent tube from the dispenser.
7. Remove the detergent dispenser screws from the front and top of the washer.

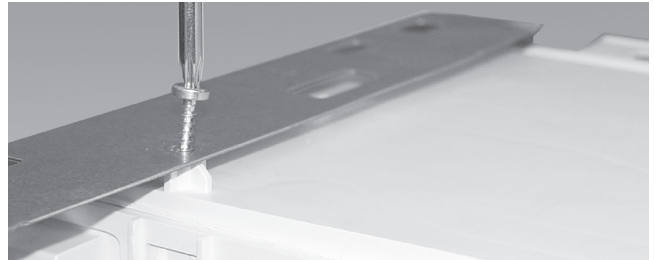

8. Lift the locking tabs and remove the two wire connectors from the detergent dispenser motor terminals.

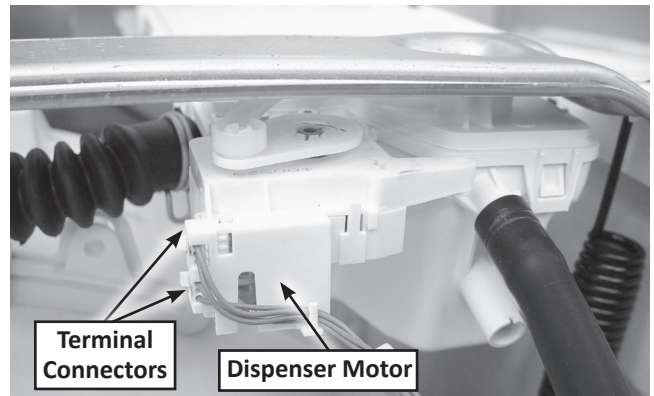

9. Remove 1 screw from the center support bracket.

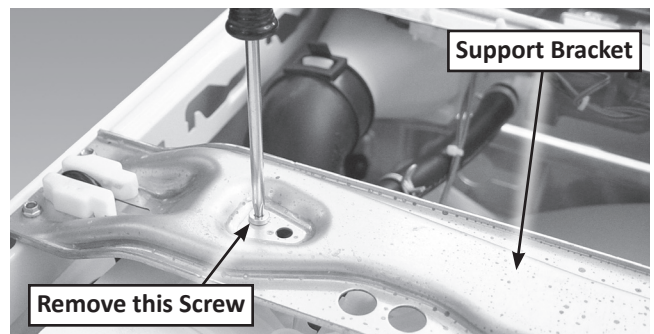

REMOVING THE DETERGENT DISPENSER ASSEMBLY (continued)

11. With a flat blade screwdriver, release the tab securing the detergent dispenser to the front support.

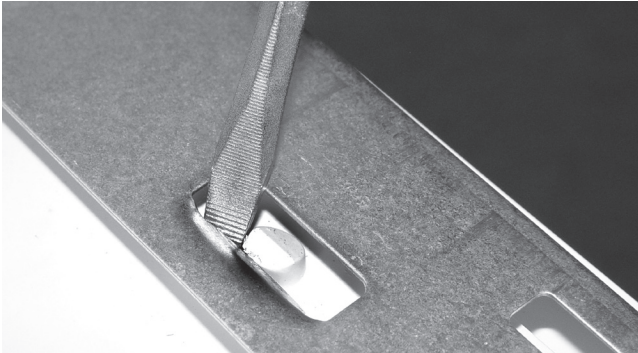

12. After all connections have been removed, push the dispenser toward the rear of the washer to release the tabs from the key slots on the chassis. Remove the dispenser assembly.

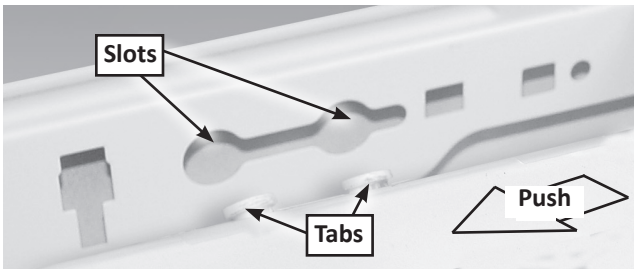

Reassembly Note:

While removing the water supply tube the nozzle will most likely remain in the tube. It must be removed from the tube and placed back into the dispenser before reconnection of the water supply tube.

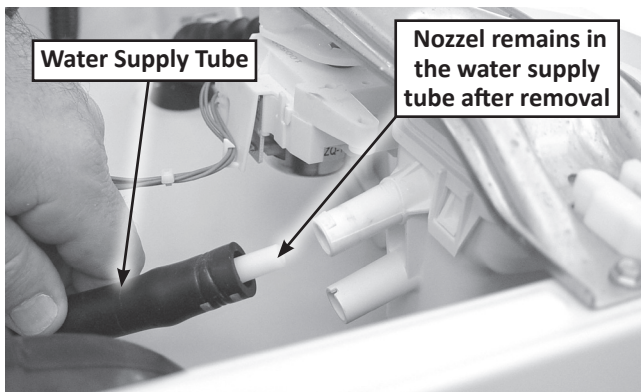

- a) Remove the nozzle from the water supply



- b) Replace the nozzle into the dispenser.



- c) Verify that the nozzle is fully seated into the water supply tube.

Once the nozzle is in place and seated all the way, Replace the water supply tube and the clamp.

REMOVING THE DETERGENT DISPENSER MOTOR

⚠ WARNING



Electrical Shock Hazard

Disconnect power before servicing.

Replace all parts and panels before operating.

Failure to do so can result in death or electrical shock.

1. Unplug washer or disconnect power.
2. Turn off the water supply to the washer.
3. Remove the top cover from the washer ("REMOVING THE DISPENSER DRAWER, TOP AND CONSOLE ASSEMBLY" for the procedure).

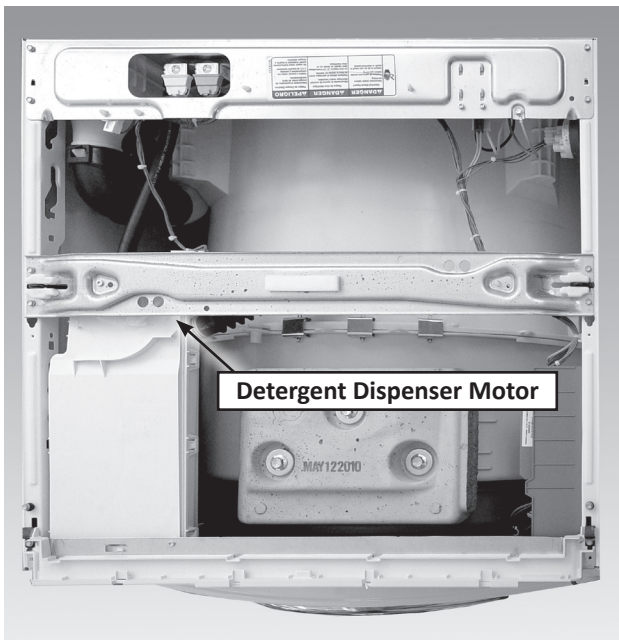

4. Lift the locking tabs and remove the two wire connectors from the detergent dispenser motor terminals.

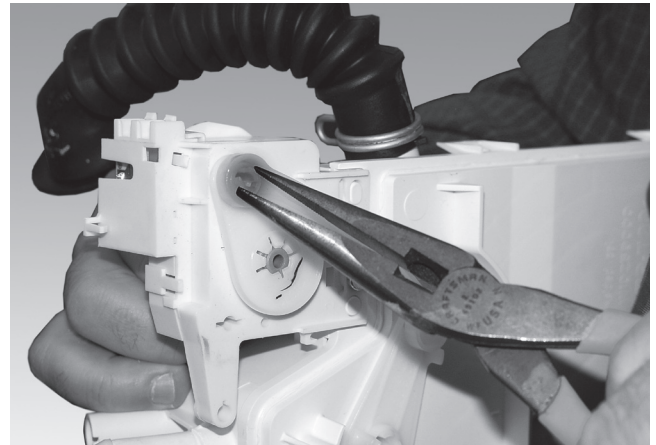

5. Using a soft touch and needle nose pliers, squeeze the "ears" on the motor shaft so that the cam actuator is released from the motor shaft.

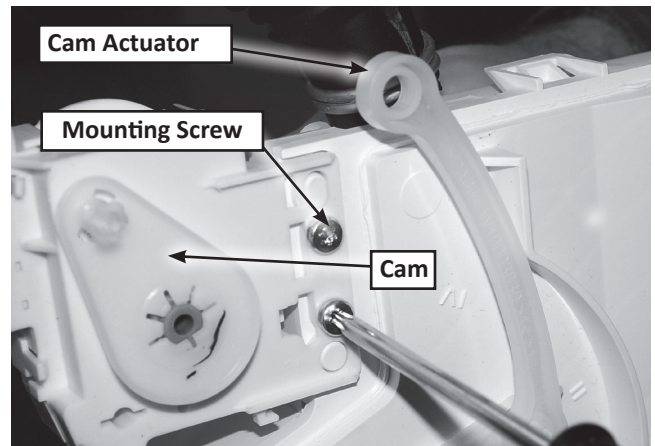

6. Remove the mounting screws from the detergent dispenser motor and remove the motor.

REMOVING THE DOOR SWITCH ASSEMBLY FRONT PANEL AND BELLOWS

⚠ WARNING



Electrical Shock Hazard
Disconnect power before servicing.
Replace all parts and panels before operating.
Failure to do so can result in death or electrical shock.

1. Unplug washer or disconnect power.
2. Turn off the water supply to the washer.
3. Remove the top cover and the console ("REMOVING THE DISPENSER DRAWER, TOP AND CONSOLE ASSEMBLY" for the procedures).
4. Open the washer door.

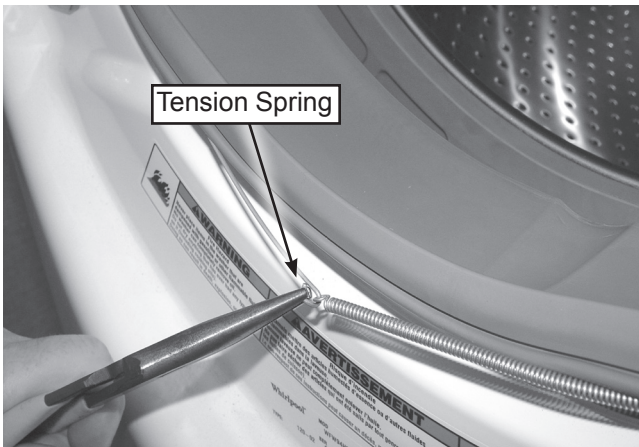

5. Using a small screwdriver or a pair of long-nosed pliers, pull the tension spring on the retaining wire out from around the front of the bellows, and remove the wire.

6. To remove the door switch assembly:

- a) Pull the bellows off the lip of the front panel beside the door switch assembly just enough to access the switch assembly.

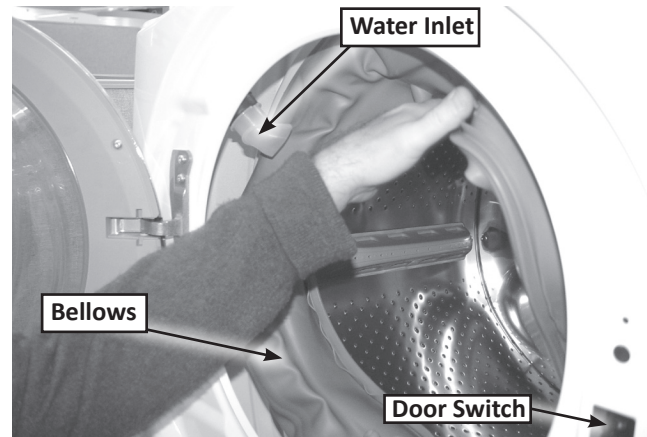

- b) Remove the two T-20 Torx screws from the door switch assembly.

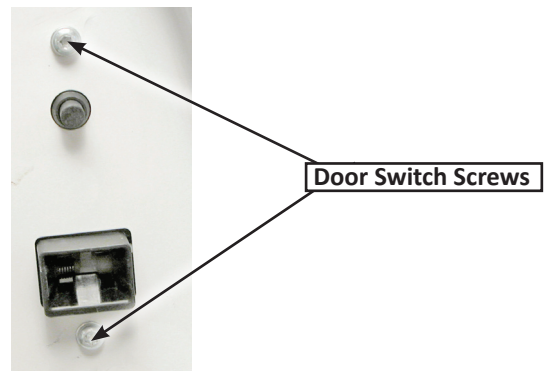

- c) Pull the door switch assembly out and turn it over so that you can access the connectors.
- d) Unlock the tabs and disconnect the wire connectors from the door switch terminals, then remove the assembly.

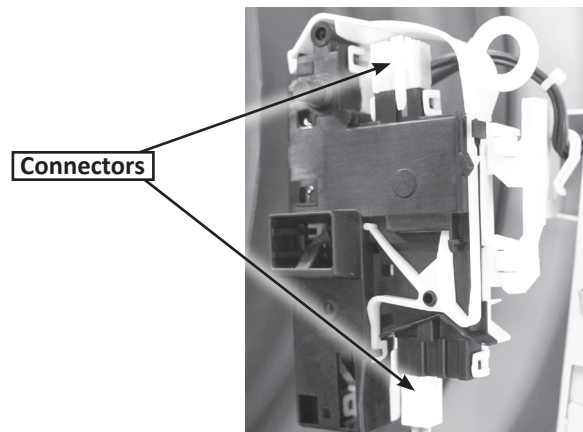

REMOVING THE DOOR SWITCH ASSEMBLY FRONT PANEL AND BELLOWS (continued)

- e) To remove the front panel:, Remove the top and console.
- f) Remove 4 screws at the bottom of the front panel.

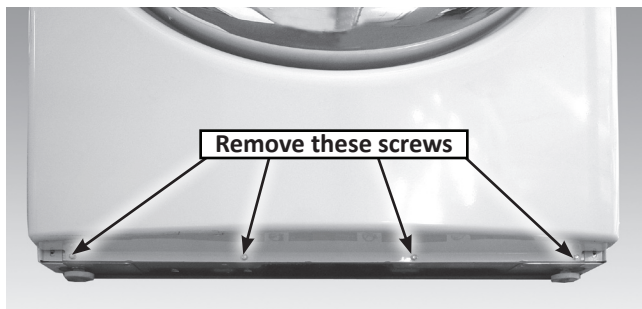

- g) Remove 3 screws at the top of the front panel. Place a piece of tape across the door and front panel to secure the door during removal.

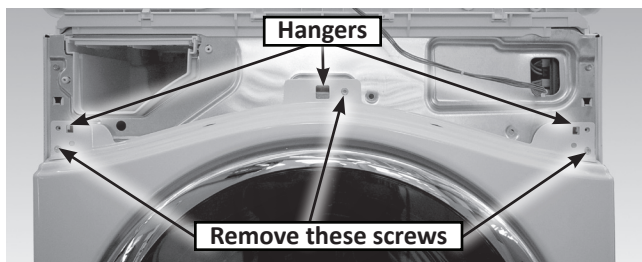

- h) Lift the front panel up and out to remove it.
NOTE: There are 3 hangers on the chassis to support the front panel during removal.

7. To remove the bellows:

- a) Remove the two T-20 Torx screws from the door switch assembly.
- b) Remove the front panel from the washer.

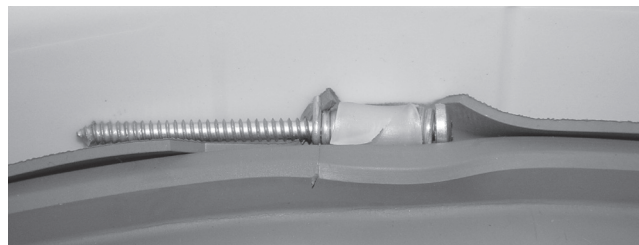
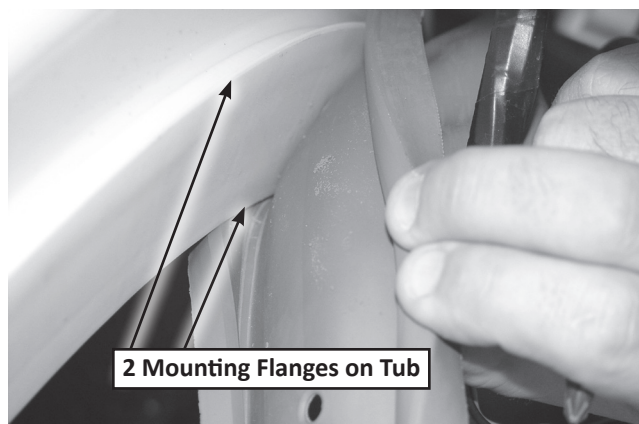

Figure 1

- c) Turn the bellows retaining clamp screw counterclockwise until the clamp is loose enough to remove it from around the bellows (see figure 1).

NOTE: It may be necessary to completely remove the screw from one end of the clamp.

Work the bellows off of the flanges.



Reassembly Note: Be sure that both the inside and out side mounting flanges are fully engaged before tightening the retaining wire. Also make sure that the "weep holes" at the center bottom of the bellows are in the proper position.

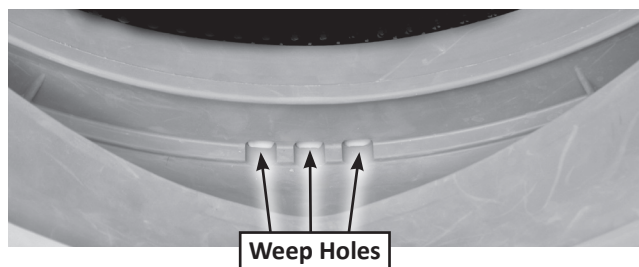

REMOVING THE DRAIN PUMP

⚠ WARNING



Electrical Shock Hazard

**Disconnect power before servicing.
Replace all parts and panels before
operating.**

**Failure to do so can result in death or
electrical shock.**

1. Unplug washer or disconnect power.
2. Turn off the water supply to the washer.
3. Remove the front panel, see ("REMOVING THE DOOR SWITCH ASSEMBLY FRONT PANEL AND BELLOWS")

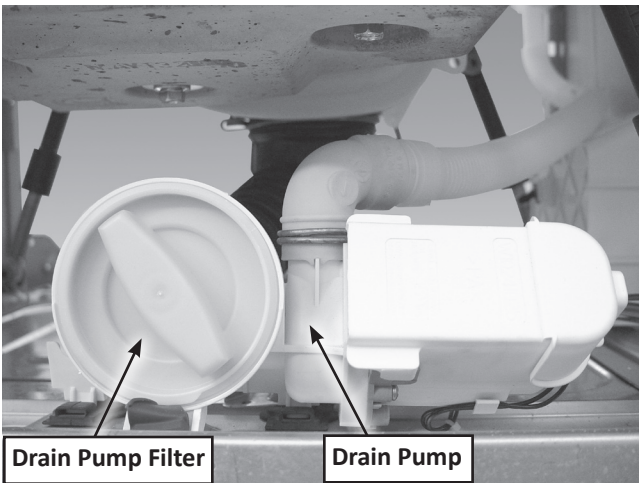

4. Using a shallow pan to catch the water, unscrew the filter from the drain pump, and drain the water from the sump.

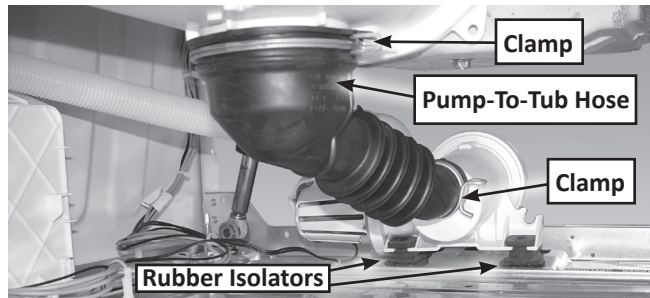

5. Loosen the clamp and remove the pump-to-tub hose from the drain pump.

REASSEMBLY NOTE: When you reconnect the hoses, align their tab(s) with the marks on the drain pump.

6. Pull the rubber tab straight out to free the "keyhole" bracket and remove the front of the drain pump.
7. Work the pump side to side while pulling forward to release the "keyholes" at the back of the pump from the rubber isolators.

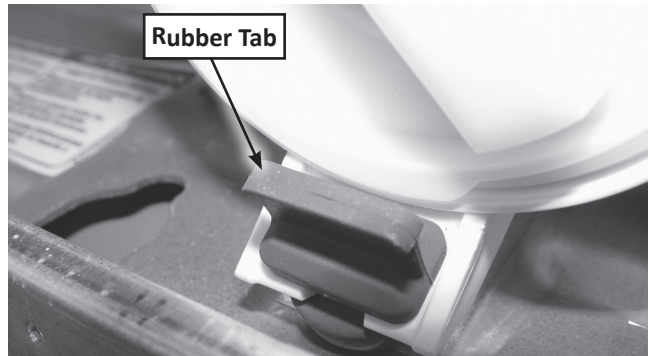

8. Lift the wire cover on the drain pump, and disconnect the wire connector from the terminals.

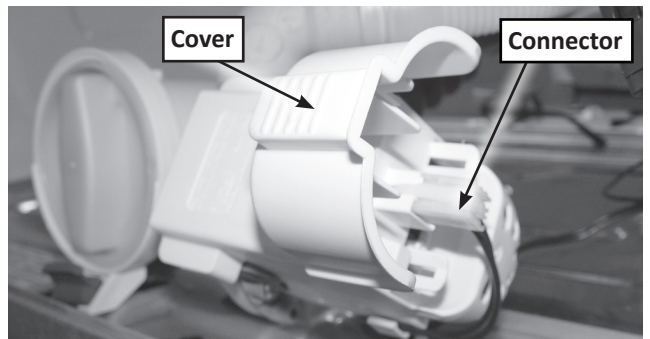

10. Remove the wires from the clip, and remove the drain pump from the washer.

REMOVING THE ECO VALVE

⚠ WARNING



Electrical Shock Hazard

**Disconnect power before servicing.
Replace all parts and panels before
operating.**

**Failure to do so can result in death or
electrical shock.**

1. Unplug washer or disconnect power.
2. Turn off the water supply to the washer.
3. Remove the front panel, see ("REMOVING THE DOOR SWITCH ASSEMBLY FRONT PANEL AND BELLOWS")

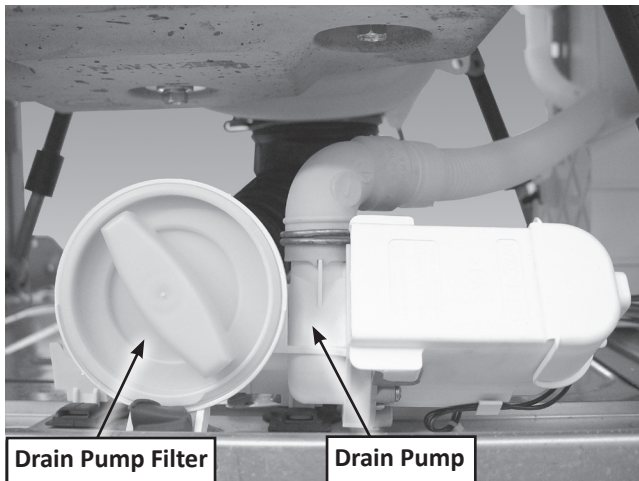

4. Using a shallow pan to catch the water, unscrew the filter from the drain pump, and drain the water from the sump.

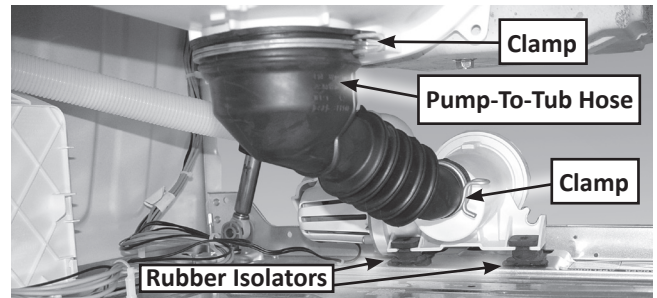

5. Pull the pressure hose off the air trap that is connected to the pump-to-tub/ECO valve hose.
6. Loosen the clamps at both ends of the pump-to-tub hose, and pull the hose/ECO valve off the tub and drain pump.

REASSEMBLY NOTE: When you reconnect the hoses, align their tab(s) with the marks on the drain pump.

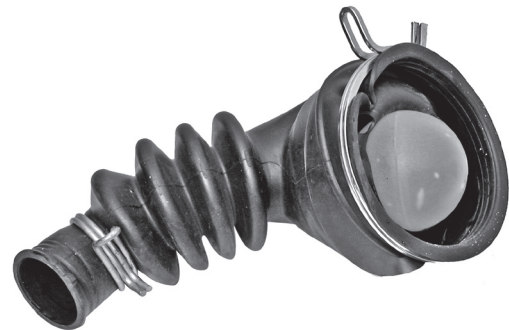

ECO Valve

REMOVING THE MOTOR CONTROL UNIT

⚠ WARNING



Electrical Shock Hazard

**Disconnect power before servicing.
Replace all parts and panels before
operating.**

**Failure to do so can result in death or
electrical shock.**

1. Unplug washer or disconnect power.
2. Turn off the water supply to the washer.
3. Pull the washer away from the wall.
4. Remove the Top ("REMOVING THE DISPENSER DRAWER, TOP AND CONSOLE ASSEMBLY") and the hex-head screws (12) (arrows) from the rear panel.

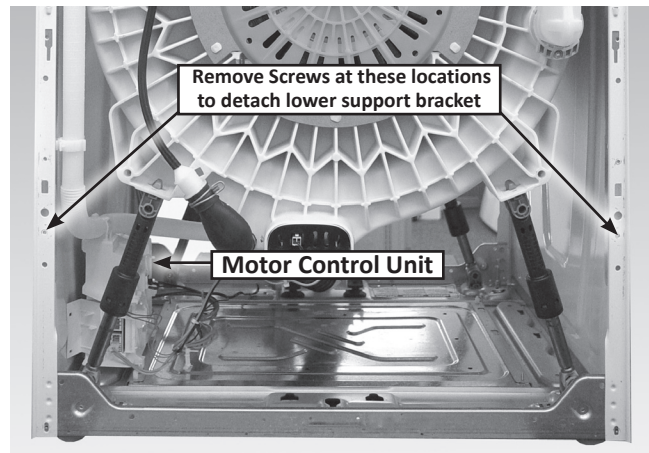

5. Remove 2 screws that secure the lower brace to have clear access to the motor control unit.

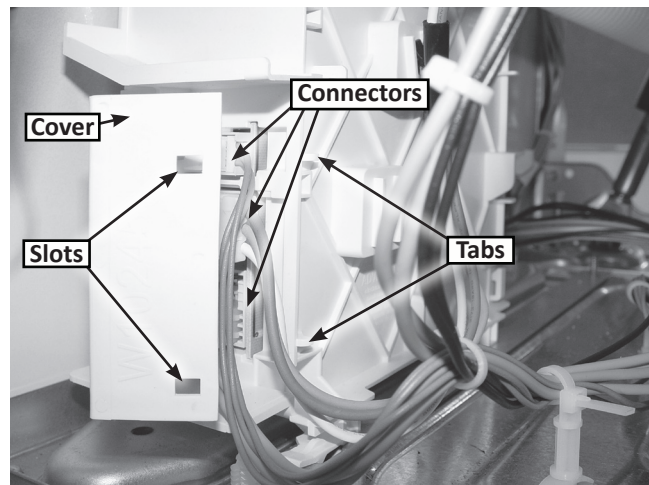

6. Release the slots from the tabs and open the connector cover and remove 3 connectors.
7. The motor control unit is secured to the washer bottom by means of 4 tabs and slots. Push up to release the tab at the corner and push the unit toward the rear of the washer to release and remove it.

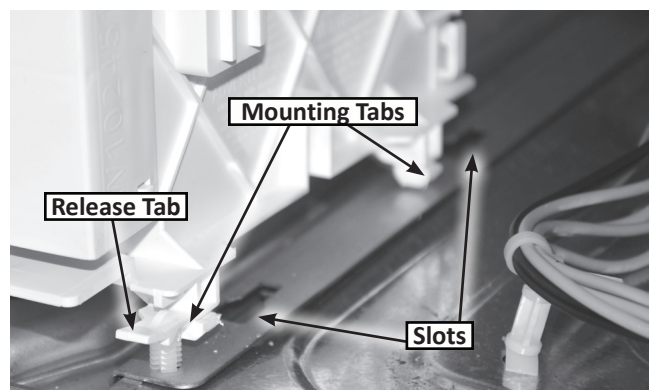

REMOVING THE VENT / FAN

1. Unplug washer or disconnect power.
2. Turn off the water supply to the washer.
3. Pull the washer away from the wall.
4. Remove the top panel from the washer ("REMOVING THE DISPENSER DRAWER, TOP AND CONSOLE ASSEMBLY" for the procedure).
5. Remove 2 screws from the back panel at the left rear corner of the washer.

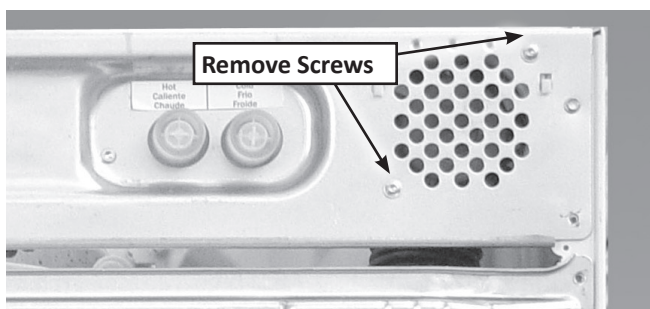

6. Disconnect fan connector.

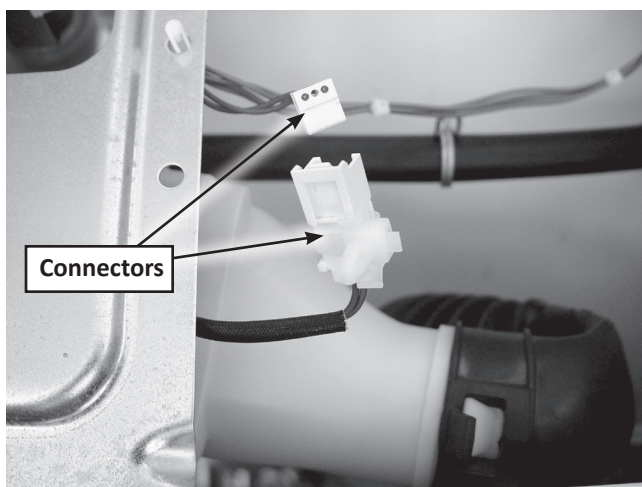

7. Remove vent tube from fan housing.

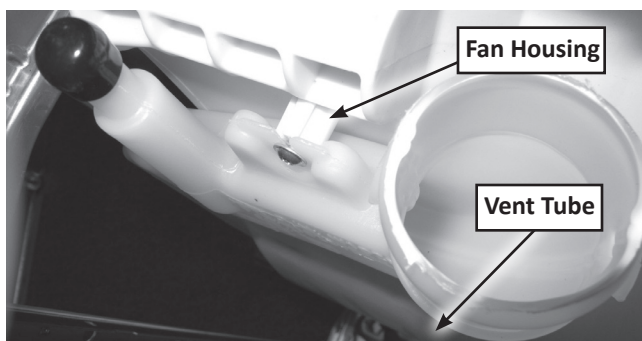

8. Remove vent /Fan assembly from washer.

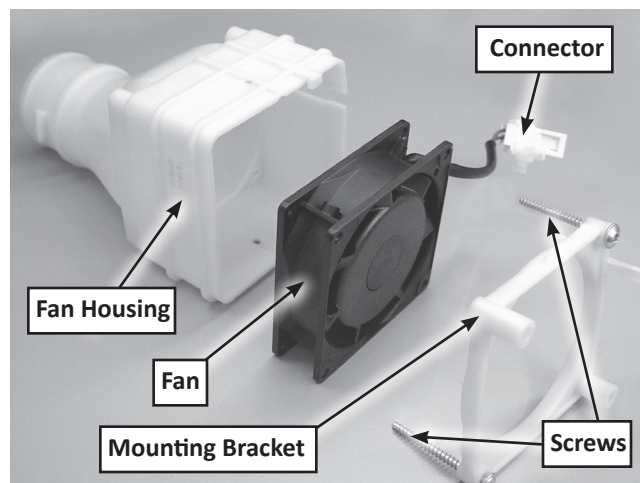

REMOVING THE TEMPERATURE SENSOR & HEATER

⚠ WARNING



Electrical Shock Hazard
Disconnect power before servicing.
Replace all parts and panels before operating.
Failure to do so can result in death or electrical shock.

1. Unplug washer or disconnect power.
2. Turn off the water supply to the washer.
3. Pull the washer away from the wall.
4. Remove the rear panel from the washer.
See ("REMOVING THE MOTOR CONTROL UNIT" for procedure.)

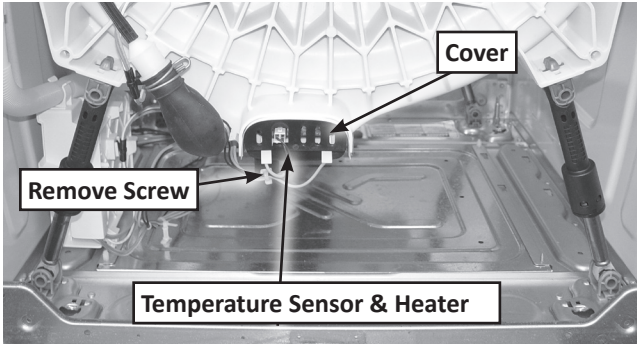

5. To remove the temperature sensor:
 - a) Remove 1 screw holding the cover in place.
 - b) Disconnect the wire connectors from the heater and temperature sensor.

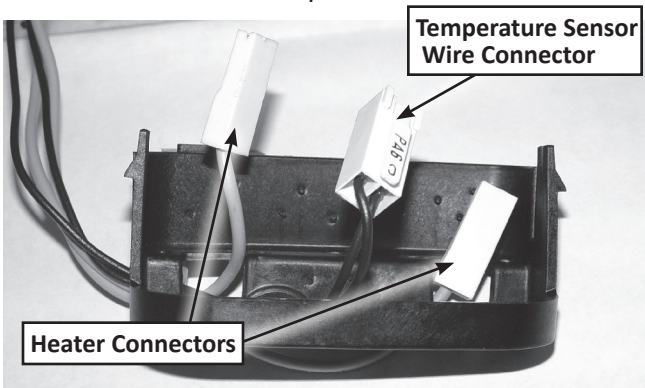

- b) Loosen the 10 mm nut and pull the temperature sensor out of the heater.

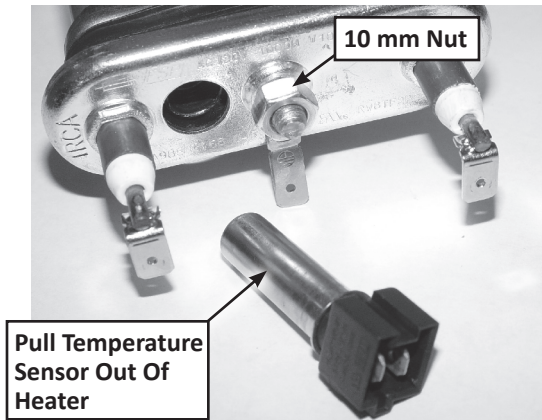

6. To remove the heater:
 - a) Remove the temperature sensor from the heater (see step 5).
 - b) Loosen (do not remove) the 10 mm nut on the heater.
 - c) Disconnect the two heater wires and the ground connector wire from the heater.

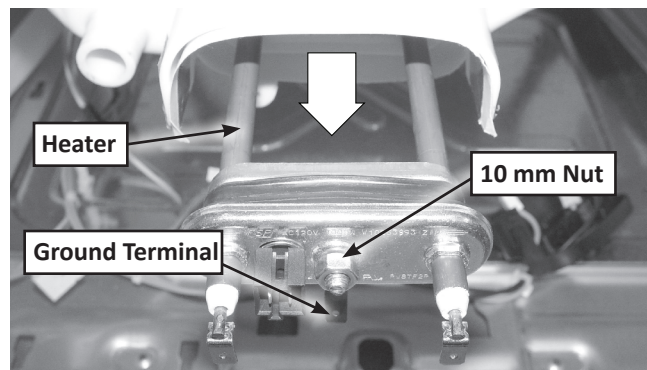

- d) Pull the heater out of the tub opening.

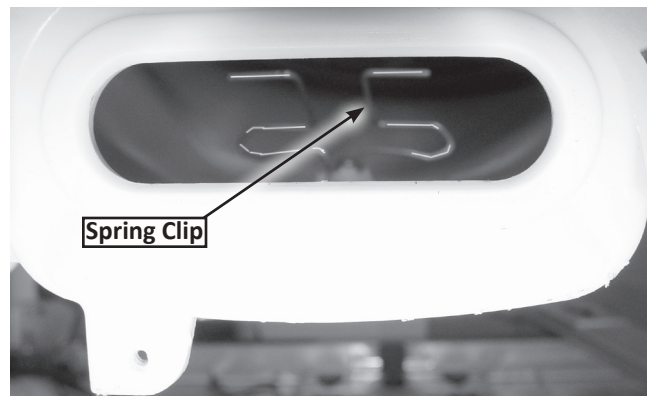

- e) When reinstalling the heater, be sure that the element is held in place by the spring clip inside the housing.

REMOVING THE MOTOR

⚠ WARNING



Electrical Shock Hazard

Disconnect power before servicing.

Replace all parts and panels before operating.

Failure to do so can result in death or electrical shock.

1. Unplug washer or disconnect power.
2. Turn off the water supply to the washer.
3. Pull the washer away from the wall.
4. Remove the top, ("REMOVING THE DISPENSER DRAWER, TOP AND CONSOLE ASSEMBLY").
5. Remove the rear panel from the washer. See ("REMOVING THE MOTOR CONTROL UNIT" for procedure.)



6. **To remove the motor**, while removing the mounting bolt for the rotor, it is necessary to keep the basket from turning. **DO NOT** hold the rotor still through the windings!!! Remove the vent tube and rotate the basket until you can see a baffle clip. Insert a screwdriver into the clip to hold the basket while removing the rotor's mounting bolt.

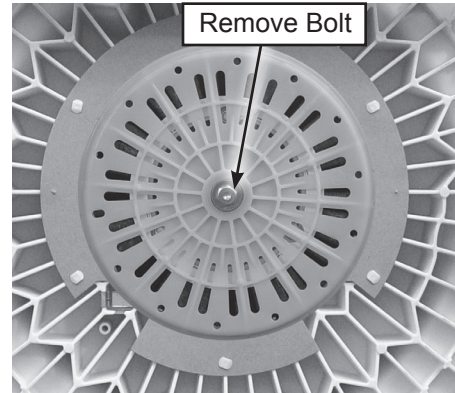
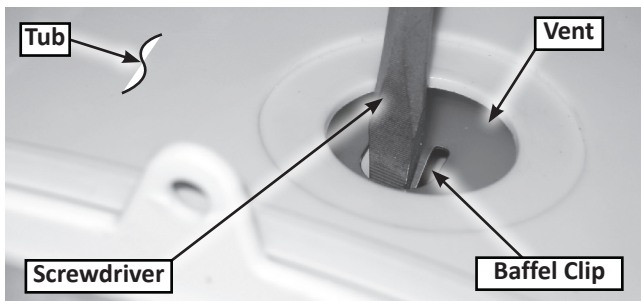

Note: Don't forget to fully reset the vent tube.

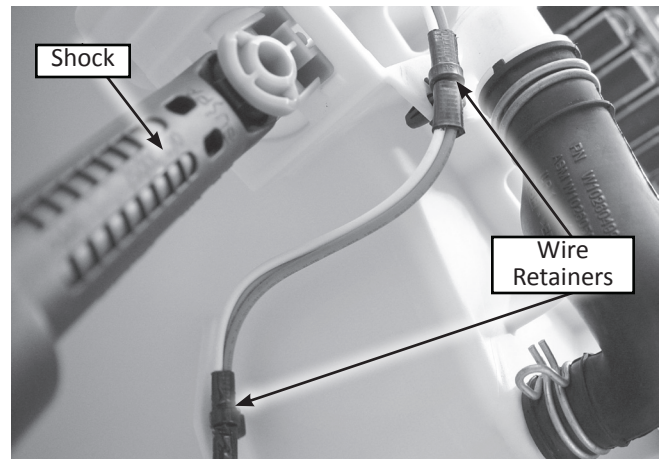

7. To remove the motor rotor:
 - a) Remove the T 40 Torx head mounting bolt from the motor.
 - b) Get a firm grip on either side of the rotor and pull straight off the spline shaft.



Note: Considerable outward force will be required to overcome the magnetic force.

REMOVING THE MOTOR (continued)

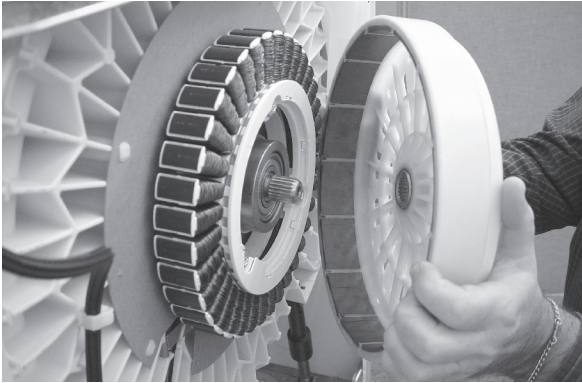

7. To remove the Stator:
 - a) Disconnect the wire connectors from the motor terminals.
 - b) Remove 3 T40 Torx head screws.
 - c) Lift the stator off of the washer.

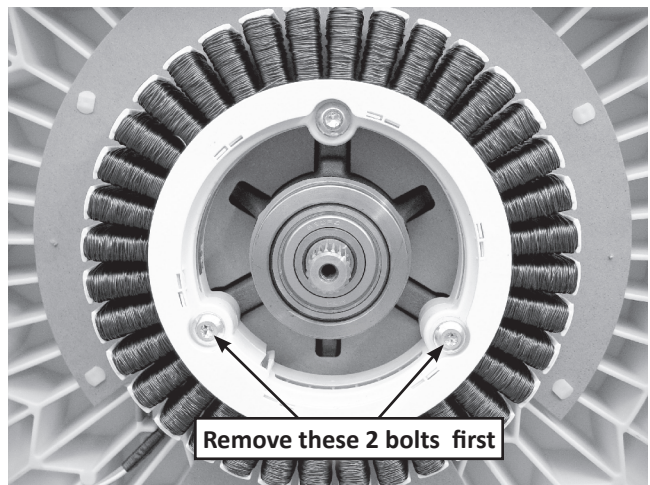

REMOVING THE TUB ASSEMBLY

⚠ WARNING



Electrical Shock Hazard

Disconnect power before servicing.

Replace all parts and panels before operating.

Failure to do so can result in death or electrical shock.

1. Unplug washer or disconnect power.
2. Turn off the water supply to the washer.
3. Pull the washer away from the wall.
4. Remove the detergent dispenser assembly ("REMOVING THE DETERGENT DISPENSER ASSEMBLY" for the procedure).
5. Loosen the clamp and remove the main water feed tube from the detergent dispenser.
6. Pull the free end of the main water feed tube from the bellows.

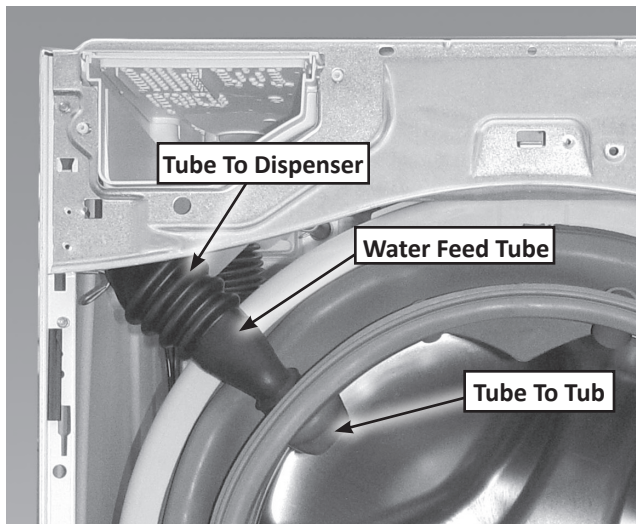

7. Remove the 2 hex-head screws from the front frame and remove the frame.

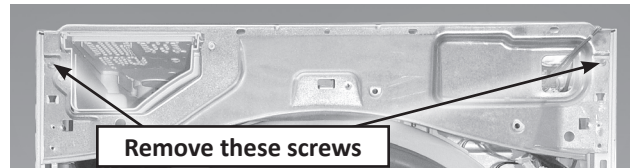
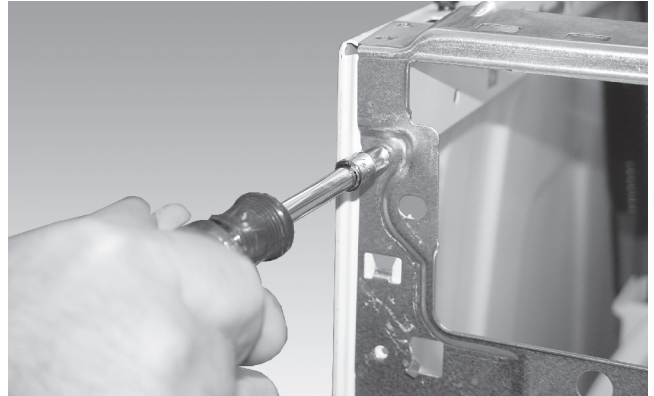

8. Remove the 1/2" bolts (3 each) from the top and bottom tub weights, and remove the weights from the tub.

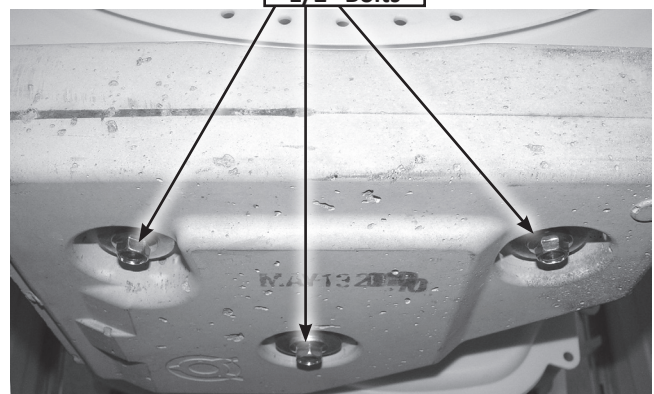
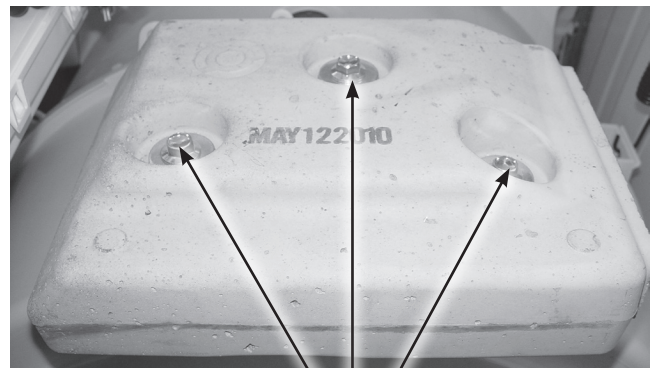

REMOVING THE TUB ASSEMBLY (continued)

9. Remove the bellows from the tub see ("REMOVING THE DOOR SWITCH ASSEMBLY FRONT PANEL AND BELLOWS" for the procedure).
10. Using a shallow pan to catch the water, unscrew the filter from the drain pump, and drain the water from the pump.

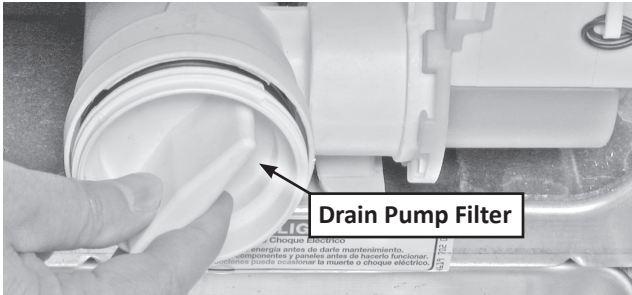

11. Loosen the clamp and remove the pump-to-tub hose from the drain pump.

REASSEMBLY NOTE: When you reconnect the hose, align the tab with the arrow on the drain pump.

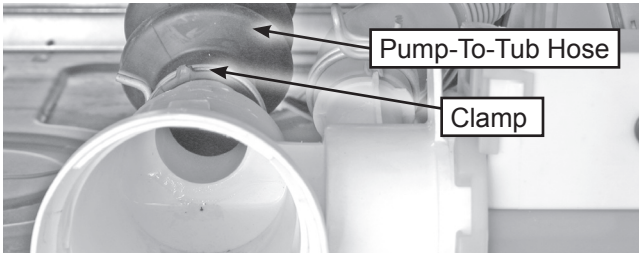

12. Remove the rear panel (see page 4-16 for the procedure).

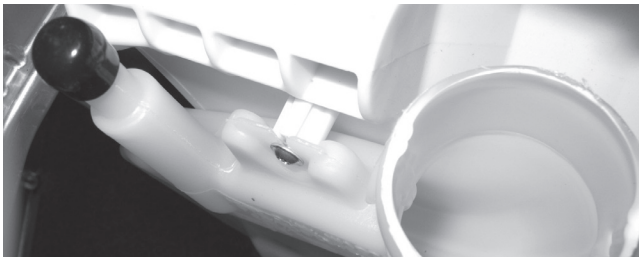

13. Remove 1 screw at the top side of the tub.



14. Remove 1 screw at the bottom back of the tub and remove the vent/fan tube-to-tub end.

15. Disconnect the pressure hose from the pressure switch.

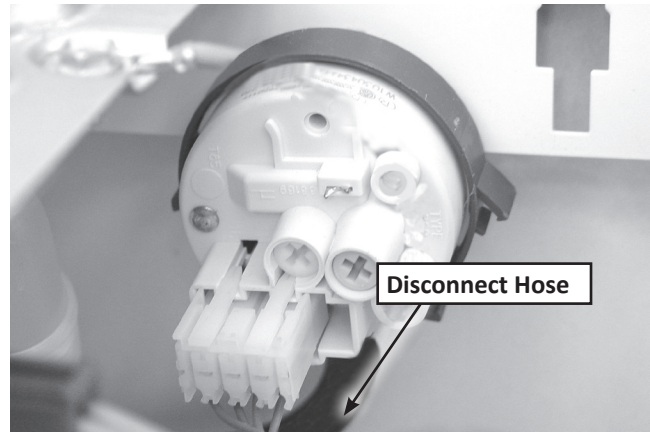

16. Remove all wire retainers securing the motor harness.
17. Remove the motor (see pages 4-19 - 4-20 for procedure).
18. Disconnect the temperature sensor and heater. (see page 4-18 for the procedure).
19. Remove the four shock absorbers from the tub. **To remove a shock absorber:**
 - a) Remove the 11/16" (17 mm) mounting bolt and nut from the base.

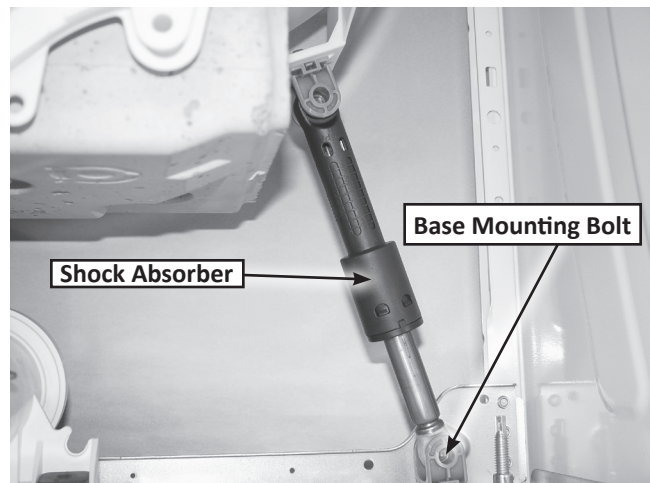

- b) Using a pair of pliers, turn the top of the shock absorber 90° so that the locking tabs align with the slots in the tub, and remove the shock absorber (see the top right photo).

REMOVING THE TUB ASSEMBLY (continued)



b) Remove the flat nuts from the tub.

Remove Flat Nuts

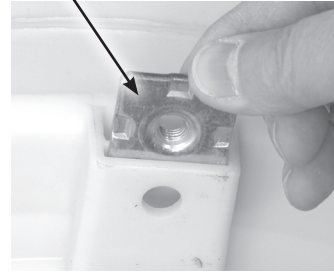

REASSEMBLY NOTE: When you reinstall the shock absorbers in the base mounting brackets, tighten the nut until it contacts the bracket, then turn the nut an additional 1/4-turn.

20. Remove the end of the vent tube from the tub.

! WARNING

Excessive Weight Hazard

Use two or more people to move and install washer.

Failure to do so can result in back or other injury.

21. To remove the tub and basket:

- a) Lift the tub and basket assembly and unhook the two suspension springs, then remove the assembly from the washer, and place it front-side down on a padded surface.

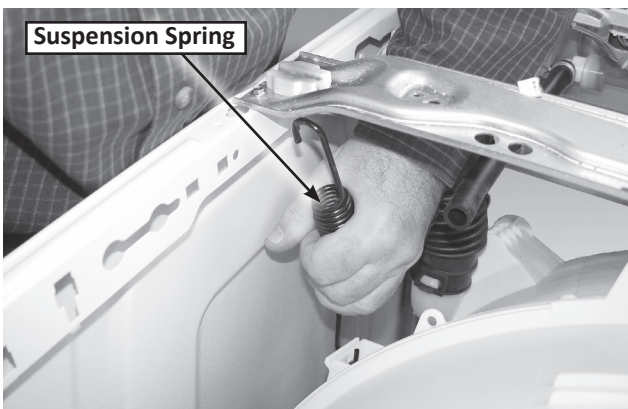

COMPONENT TESTING

FOR SERVICE TECHNICIAN'S USE ONLY

DANGER



Electrical Shock Hazard

Only authorized technicians should perform diagnostic voltage measurements.

After performing voltage measurements, disconnect power before servicing.

Failure to follow these instructions can result in death or electrical shock.

WARNING



Electrical Shock Hazard

Disconnect power before servicing.

Replace all parts and panels before operating.

Failure to do so can result in death or electrical shock.

Voltage Measurement Safety Information

When performing live voltage measurements, you must do the following:

- Verify the controls are in the off position so that the appliance does not start when energized.
- Allow enough space to perform the voltage measurements without obstructions.
- Keep other people a safe distance away from the appliance to prevent potential injury.
- Always use the proper testing equipment.
- After voltage measurements, always disconnect power before servicing.

IMPORTANT: Electrostatic Discharge (ESD) Sensitive Electronics

ESD problems are present everywhere. Most people begin to feel an ESD discharge at approximately 3000V. It takes as little as 10V to destroy, damage, or weaken the main control assembly. The new main control assembly may appear to work well after repair is finished, but a malfunction may occur at a later date due to ESD stress.

- Use an anti-static wrist strap. Connect wrist strap to green ground connection point or unpainted metal in the appliance

-OR-

Touch your finger repeatedly to a green ground connection point or unpainted metal in the appliance.

- Before removing the part from its package, touch the anti-static bag to a green ground connection point or unpainted metal in the appliance.
- Avoid touching electronic parts or terminal contacts; handle electronic control assembly by edges only.
- When repackaging main control assembly in anti-static bag, observe above instructions.

IMPORTANT SAFETY NOTICE — “For Technicians only”

This service data sheet is intended for use by persons having electrical, electronic, and mechanical experience and knowledge at a level generally considered acceptable in the appliance repair trade. Any attempt to repair a major appliance may result in personal injury and property damage. The manufacturer or seller cannot be responsible, nor assume any liability for injury or damage of any kind arising from the use of this data sheet.

COMPONENT TESTING (continued) FOR SERVICE TECHNICIAN'S USE ONLY

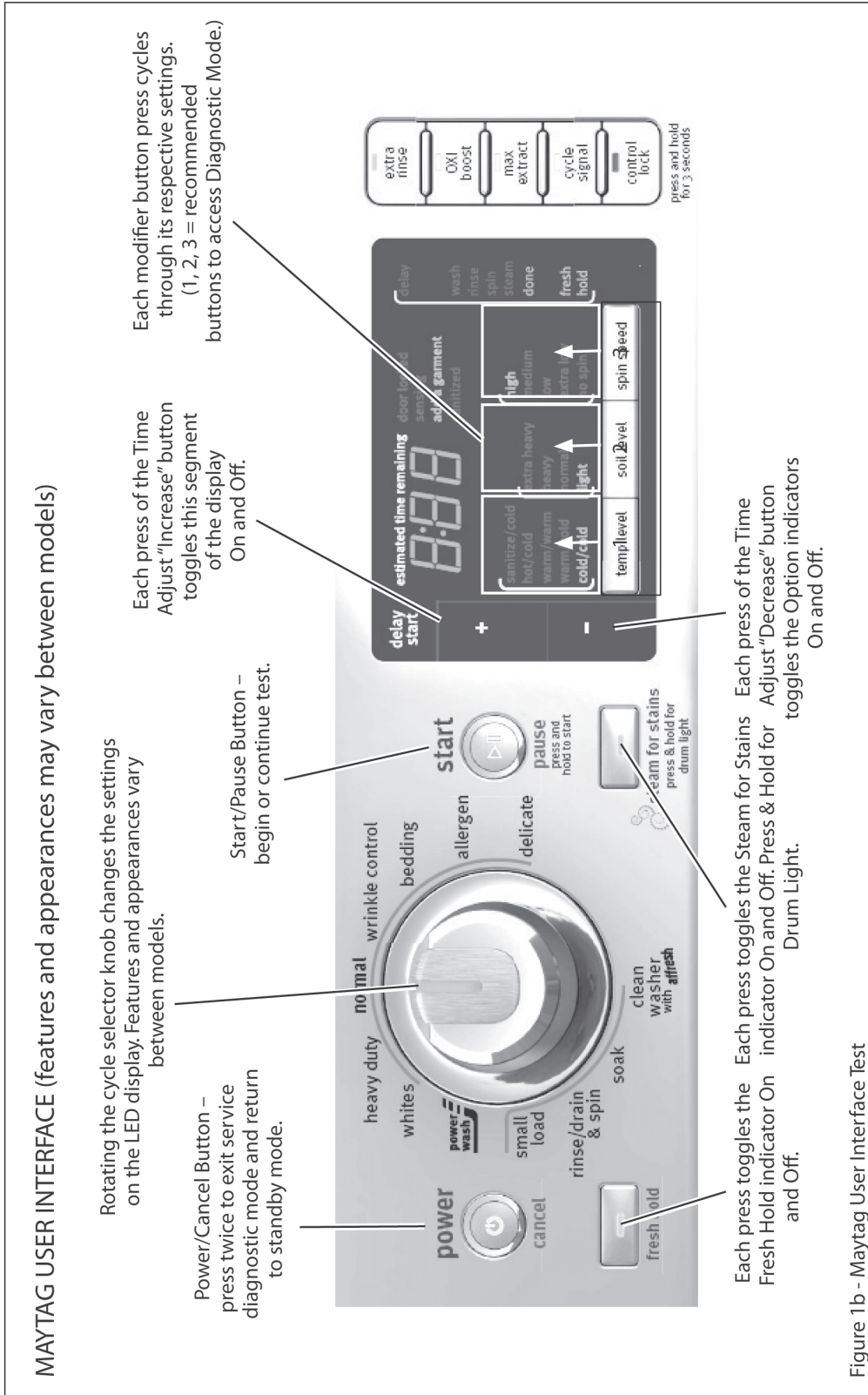

Figure 1b - Maytag User Interface Test

COMPONENT TESTING (continued) FOR SERVICE TECHNICIAN'S USE ONLY

DIAGNOSTIC GUIDE

Before servicing, check the following:

- Make sure there is power at the wall outlet.
- Has a household fuse blown or circuit breaker tripped? Was a regular fuse used? Inform customer that a time-delay fuse is required.
- Are both hot and cold water faucets open and water supply hoses unobstructed?
- All tests/checks should be made with a VOM (volt-ohm-milliammeter) or DVM (digital-voltmeter) having a sensitivity of 20,000 Ω per volt DC or greater.
- Resistance checks must be made with washer unplugged or power disconnected.
- **IMPORTANT:** Avoid using large diameter probes when checking harness connectors as the probes may damage the connectors upon insertion.
- Check all harnesses and connections before replacing components. Look for connectors not fully seated, broken or loose wires and terminals, pin insertion, or wires not pressed into connectors far enough to engage metal barbs.
- A potential cause of a control not functioning is corrosion or contamination on connections. Use an ohmmeter to check for continuity across suspected connections.

SERVICE DIAGNOSTIC MODE

These tests allow factory or service personnel to test and verify all inputs to the machine control electronics. You may want to do a quick and overall checkup of the washer with these tests before going to specific troubleshooting tests.

ACTIVATING SERVICE DIAGNOSTIC MODE

1. Be sure the washer is in standby mode (plugged in with all indicators off).
2. Select any three buttons and follow the steps below, using the same buttons (remember the buttons and the order that the buttons were pressed):

Within 8 seconds,

- Press and Release the 1st selected button,
- Press and Release the 2nd selected button,
- Press and Release the 3rd selected button;
- Repeat this 3 button sequence 2 more times.

3. If this test mode has been entered successfully, all indicators on the console are illuminated for 5 seconds with "888" showing in the Estimated Time Remaining three-digit display. If there are no saved fault codes, all indicators on the console will momentarily turn off, and then only the seven segment display will come back on and display "888".

NOTE: The service diagnostic mode will time out after 5 minutes of user inactivity, or shut down if AC power is removed.

SERVICE DIAGNOSTIC MENU TABLE

	Button Press	Function Behavior
1st Button	- Momentary press - Press and hold for 5 secs.	- Activates User Interface Test - Exits Service Diagnostics
2nd Button	- Momentary press - Press and hold for 5 secs.	- Activates Quick Diagnostics - Software Version Display
3rd Button	- Momentary press - Press and hold for 5 secs.	- Displays Next Error Code - Clears the Error Codes

COMPONENT TESTING (continued) FOR SERVICE TECHNICIAN'S USE ONLY

Unsuccessful Activation

If entry into diagnostic mode is unsuccessful, refer to the following indications and actions:

Indication 1: None of the LED's or display turn on.

Action: Select any cycle.

- If indicators come on, try to change the function for the three buttons used to activate the diagnostic test mode. If any button is unable to change the function, something is faulty with the button, and it will not be possible to enter the diagnostic mode using that button. Replace the user interface and housing assembly.
- If no indicators come on after selecting the cycle, go to TEST #1.

Indication 2: Console indicators begin flashing immediately.

Action: If console indicators begin flashing on and off immediately, replace the user interface.

Activation with Saved Fault Codes

If there is a saved fault code, it will be flashing in the display. Review the Fault/Error Codes table on pages 8–10 for the recommended procedure. If there is no saved fault code, "888" will be displayed.

USER INTERFACE TEST (Figure 1)

NOTE: The Service Diagnostic mode must be activated before entering the User Interface Test.

Active Fault Code Display in User Interface Test

If the display begins flashing while in User Interface Test, it is displaying an active fault code. Active fault codes are codes that are currently detected. Only one active fault code can be displayed at a time.

Entry Procedure

Press and release the 1st button used to activate Service Diagnostic mode.

User Interface Test

Pressing buttons and rotating the cycle selector knob will turn on/off the corresponding indicator and sound a beep as shown in figure 1, User Interface Test. If indicators do not come on and beep after pressing buttons and rotating the cycle selector knob, go to TEST #2: User Interface.

NOTE: A second press of the POWER button while in User Interface Test mode exits the Service Diagnostic mode and returns the washer to standby mode.

Exit Procedure

To exit User Interface Test, press and hold the 1st button used to activate Service Diagnostic mode for 5 seconds.

QUICK DIAGNOSTICS

NOTE: The Service Diagnostic mode must be activated before entering Quick Diagnostics; see procedure. If, at any point, the user presses the power button, the washer exits to standby mode.

Active Fault Code Display in Quick Diagnostics

If the display begins flashing while in Quick Diagnostics, it is displaying an active fault code. Active fault codes are codes that are currently detected. Only one active fault code can be displayed at a time.

Entry Procedure

To enter Quick Diagnostics, press and release the 2nd button used to activate the Service Diagnostic mode. All LEDs turn off and the START button begins to flash. Press the START button to perform the Quick Diagnostics tests listed on page 6. Each test phase is indicated on the display.

Exit Procedure

When test is complete, press the POWER button to exit Quick Diagnostics and return to standby mode.

COMPONENT TESTING (continued) FOR SERVICE TECHNICIAN'S USE ONLY

QUICK DIAGNOSTIC TEST			
TEST PHASE	WASHER FUNCTION	COMPONENT	STEP ENDS...
C00	Door lock motor is actuated. Door unlocks, and then locks again. Pump is activated for 15 seconds.	*Door lock system *Drain Pump	on completion only.
C01	Heater is turned on. Steam valve is actuated.	* Heater * Steam Valve * Temperature Sensor	on completion or at key press.
C02	Cold water valve will actuate.	* Flow Meter * Cold Water Valve	on completion or at key press.
C03	Dispensing system is set to the Prewash position.	*Dispenser Motor *Dispenser Contact	on completion only.
C04	Hot water valve will actuate.	* Hot Water Valve	on completion or at key press.
C05	Drum rotates clockwise at wash speed.	* Motor * Motor Control Unit (MCU)	on completion or at key press.
C06	Heater is turned on. Drum rotates clockwise at wash speed. The water valve is activated to fill drum to minimum water volume required to wash. (If there is enough water in the drum, the water valve will not turn on.)	*Heater *Water Temperature Sensor *Pressure Sensor	on completion or at key press.
C07	Drain Pump is actuated until there is no water in the system—plus an additional 15 seconds.	* Drain Pump * Pressure Sensor	on completion only.
C08	Drum rotates counterclockwise from 35 rpm > 100 rpm > 150 rpm > 100 rpm in 4 minutes.	* Motor * Motor Control Unit	on completion only.
	Drum rotates counterclockwise at maximum speed.	* Motor * Motor Control Unit	on completion or at key press.

SOFTWARE VERSION DISPLAY

NOTE: The Software Version Display mode will time out after 5 minutes of user inactivity and return to standby mode.

Entry Procedure

To enter Software Version Display, press and hold the 2nd button used to activate the Service Diagnostic mode for 5 seconds. Press the START button to cycle through the following information:

- CCU (Software Version, EEPROM Version)
- UI (Software Version, EEPROM Version)
- MCU (Software Version)

Exit Procedure

Press the POWER button to exit Software Version Display and return to standby mode.

FAULT/ERROR CODES

(Refer to fault/error code charts on pages 8–10.)

Fault/Error Code Display Method

Fault codes are displayed by alternately showing F# and E#. All fault codes have an F# and an E#. The F# indicates the suspect System/Category. The E# indicates the suspect Component system.

COMPONENT TESTING (continued) FOR SERVICE TECHNICIAN'S USE ONLY

Advancing Through Saved Fault/ Error Codes

Procedure for advancing through saved fault codes:

Press and release the 3rd button used to activate Service Diagnostics	g	beep tone	g	most recent fault code is displayed.
Repeat	g	beep tone	g	second most recent fault code is displayed.
Repeat	g	beep tone	g	third most recent fault code is displayed.
Repeat	g	beep tone	g	fourth most recent fault code is displayed.
Repeat	g	triple beep	g	back to the most recent fault code.

Up to four Fault/Error codes may be stored. When the oldest fault code is displayed, additional presses of the 3rd button will result in a triple beep, then display of the most recent fault code. If each press of the 3rd button results in a triple beep and the display shows "888", no saved fault codes are present.

NOTE: After 10 consecutive cycles without a fault, the error code will be removed from memory.

Clearing Fault Codes

To clear fault codes, enter Service Diagnostic mode. Then press and hold the 3rd button used to enter Service Diagnostic mode for 5 seconds. Once the fault codes are successfully erased, the seven segment display will show "888".

EXITING SERVICE DIAGNOSTIC MODE

Use either of the two methods below to exit diagnostic mode.

- Pressing the POWER button twice.
- Pressing and holding the 1st button used to activate the Service Diagnostic mode for 5 seconds.

COMPONENT TESTING (continued) FOR SERVICE TECHNICIAN'S USE ONLY

TEST PROCEDURES

IMPORTANT: The following procedures may require the use of needle probes to measure voltage. Failure to use needle probes will damage the connectors. To ease the process of measuring voltage and resistance, test points for each pin are accessible through the slots in the plastic beneath each CCU connector.

TEST #1: Cycle Control Unit/Power Check

This test checks for incoming and outgoing power to and from Cycle Control Unit (CCU). This test assumes that proper voltage is present at the outlet.

1. Unplug washer or disconnect power.
2. Remove top panel to access the machine electronics.
3. Visually check that all connections to the interference filter are securely connected.
4. Visually check that all connections to the CCU are fully inserted.
5. If both visual checks pass, go to step 6.
6. Plug in washer or reconnect power.
7. With a voltmeter set to AC, check for line voltage at the input of the interference filter. See Figure 3.
 - If line voltage is present, go to step 8.
 - If line voltage is not present, verify the continuity of the power cord. If it fails the continuity check, replace the power cord.
8. With a voltmeter set to AC, check for line voltage at the output of the interference filter. See Figure 3.
 - If line voltage is present, go to step 9.
 - If line voltage is not present, replace the interference filter.
9. With a voltmeter set to AC, check for input line voltage to the CCU across pins 1 and 2 of connector. IF2
 - If line voltage is present, go to step 10.
 - If line voltage is not present, check harnesses and connections between the filter and the CCU. Repair as necessary.

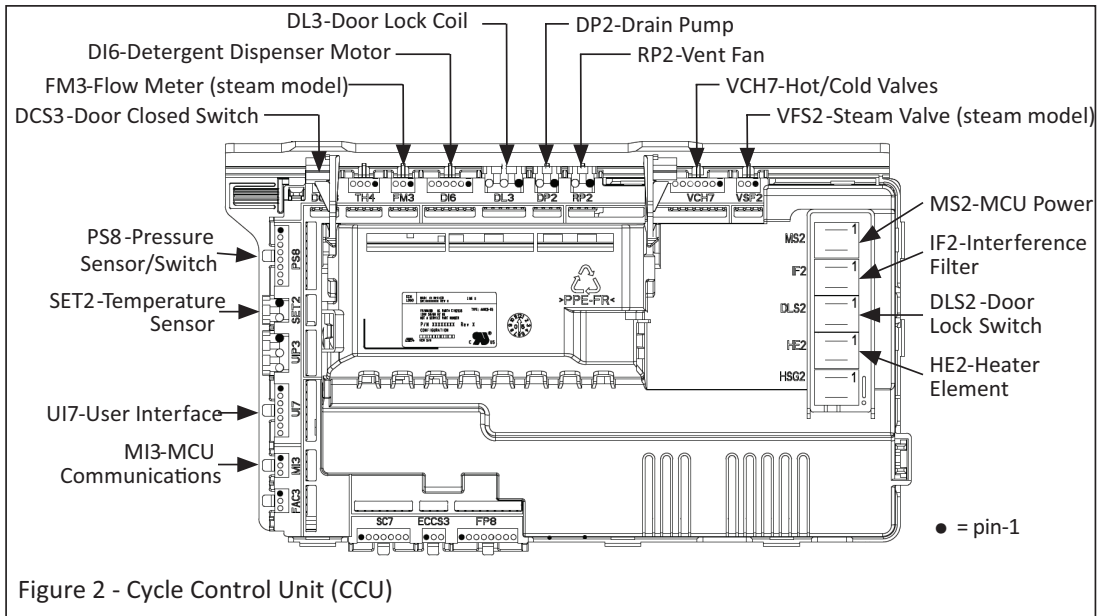

Figure 2 - Cycle Control Unit (CCU)

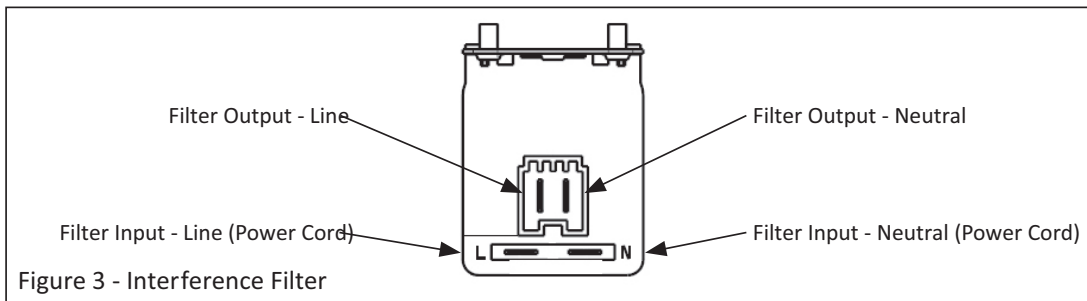

Figure 3 - Interference Filter

COMPONENT TESTING (continued) FOR SERVICE TECHNICIAN'S USE ONLY

10. DC Supplies

- +5VDC is used to power IC's and processors on the circuit boards. If +5 VDC was missing, the washer would become unresponsive. To verify +5VDC \pm 5%, measure voltage at UI7 pin 7 (GND) to pin 2 (+5V [Vcc]). (Red lead to Vcc.)
- +12VDC is used to actuate most of the 120VAC relays, triacs, and switches on the CCU. If +12VDC was missing, the motors, valves, and pumps would not turn on. To verify +12VDC \pm 5%, measure voltage at UI7 pin 3 (-7V) to pin 2 (+5V [Vcc]). (Red lead to Vcc.)

Troubleshooting: Refer to the wiring diagrams on pages 23–24 when troubleshooting the DC supplies. If +5 or +12 VDC is missing on the CCU, unplug washer or disconnect power, and then disconnect all components from the CCU relying on that supply. Plug in washer or reconnect power and check if the DC supply has returned. If not, replace the CCU. If it has, turn washer off and reconnect one connector at a time until the component loading down that supply has been identified.

11. Unplug washer or disconnect power.
12. Reassemble all parts and panels.
13. Perform the "Quick Diagnostic Test" to verify repairs.

TEST #2: User Interface (UI)

This test is performed when any of the following situations occurs during the User Interface Test:

- ✓ None of the indicators or display turn on
- ✓ Some buttons do not light indicators
- ✓ No beep sound is heard

None of the indicators or display turn on:

1. Unplug washer or disconnect power.
2. Remove the top panel to access the CCU and user interface (UI).
3. Visually check that ALL CCU connectors are inserted all the way into the CCU.
4. Visually check that ALL UI connectors are inserted all the way into the UI.
5. Visually check that the UI and housing assembly is properly inserted into the front console.
6. If all visual checks pass, perform TEST #1: CCU Power Check, to verify supply voltages.

- If supply voltages are present, replace the user interface and housing assembly.
- If supply voltages are not present, replace the CCU.

7. Reassemble all parts and panels.

8. Plug in washer or reconnect power.

9. Perform the "User Interface Test" to verify repair.

Some buttons do not light indicators:

1. Unplug washer or disconnect power.
2. Remove the top panel to access the CCU and user interface (UI).

3. Visually check that the UI and housing assembly is properly inserted into the front console.

4. If visual check passes, replace the UI and housing assembly.

5. Reassemble all parts and panels.

6. Plug in washer or reconnect power.

7. Perform the "User Interface Test" to verify repair.

No beep sound is heard:

1. Unplug washer or disconnect power.
2. Remove the top panel to access the CCU and user interface (UI).
3. Visually check that ALL CCU connectors are inserted all the way into the CCU.
4. Visually check that ALL UI connectors are inserted all the way into the UI.
5. If all visual checks pass, replace the UI and housing assembly.
6. Perform the "User Interface Test" to verify repair.

TEST #3: Motor Circuit

This test checks the motor, motor control unit (MCU), and wiring.

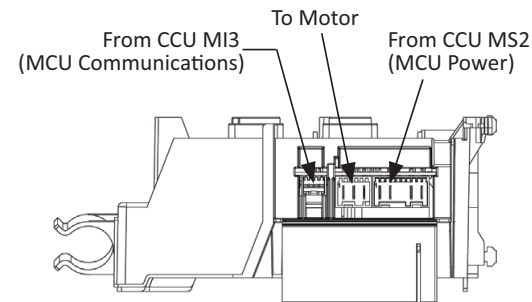

Figure 4 - Motor Control Unit (MCU)

COMPONENT TESTING (continued) FOR SERVICE TECHNICIAN'S USE ONLY

IMPORTANT: A guide (W10271535) is required to assemble the rotor onto the shaft. W10271535 is inserted into the threaded hole, and then the rotor is slid on over the guide.

NOTE: If the harness between the CCU and MCU is removed or communications are interrupted during operation, the MCU puts the motor into a braking mode, resulting in a significant drag on the drum when turned by hand. This mode can be cleared by removing power from the washer for a few seconds.

1. Check the motor and electrical connections by performing the "Quick Diagnostic Test" on pages 5–6. The following steps assume that this step was unsuccessful.

2. Unplug washer or disconnect power.

3. Check to see if basket will turn freely.

➤ If basket turns freely, go to step 4.

➤ If basket does not turn freely, determine what is causing the mechanical friction or lockup.

4. Remove the top and rear panels to access the machine electronics and motor components.

5. Visually check that connectors MS2 and MI3 are inserted all the way into the CCU. Refer to CCU diagram.

➤ If visual checks pass, go to step 6.

➤ If visual checks fail, reconnect MS2 and MI3, and repeat step 1.

6. Visually check that all connectors are inserted all the way into the MCU (see Figure 4).

➤ If visual checks pass, go to step 7.

➤ If visual checks fail, reconnect the MCU connectors and repeat step 1.

7. Check the motor windings. Disconnect the motor harness from the MCU. With an ohmmeter, verify the resistance values as shown below:

Motor Harness	Windings (Ω)
Pins 1 & 2	8.5 - 14.0 Ω
Pins 2 & 3	8.5 - 14.0 Ω
Pins 1 & 3	8.5 - 14.0 Ω

➤ If the values are outside the range or open, replace stator assembly; otherwise, reconnect the motor harness and go to step 8.

8. Check the two harnesses between the CCU and MCU for continuity.

➤ If there is continuity, go to step 9.

➤ If there is no continuity, replace the main lower harness.

9. With a voltmeter set to AC, connect the leads across pins 1 and 2 of connector MS2.

10. Plug in washer or reconnect power.

11. Run the "Quick Diagnostic Test" on pages 5–6. **IMPORTANT:** Door must be closed and locked to run motor.

12. When the test shows "C05 & C08" on the display, the motor is powered and line voltage from the CCU should be present across pins 1 & 2 of connector MS2.

➤ If line voltage is present, replace the MCU.

➤ If line voltage is not present, replace the CCU.

13. Unplug washer or disconnect power.

14. Reassemble all parts and panels.

15. Perform the "Quick Diagnostic Test" to verify repair.

TEST #4: Door Lock System

Perform the following checks if the washer does not lock (or unlock).

1. Check lid lock mechanism for obstruction or binding. Repair as necessary.

2. Unplug washer or disconnect power.

3. Remove top panel to access machine electronics.

4. Visually check that the DL3, DLS2, and DCS3 connectors are inserted all the way into the CCU. Refer to CCU diagram.

➤ If visual check passes, go to step 5.

➤ If any of the connectors are not inserted properly, reconnect and retest door lock.

5. Referring to the chart below, disconnect the specified connectors from the CCU. With an ohmmeter, verify resistance values listed in the chart. **NOTE:** To measure the door lock switch in the "locked" position, plug in washer or reconnect power. Press the POWER button, select any cycle, and then press START.

Actuation of the door lock solenoid should be heard. At that point, unplug the washer and disconnect DLS2 from the CCU and measure resistance across pins 1 & 2.

DOOR LOCK RESISTANCE			
Component	Resistance	Contacts Measured	
Door Switch	Door Closed = 0 ohms	DCS3-1	DCS3-3
	Door Open = Open Circuit		
Door Lock Coils	63 ohms	DL3-1	DL3-2
	63 ohms	DL3-2	DL3-3
Door Lock Switch	Locked = 0 ohms Unlocked = Open Circuit	DLS2-1	DLS2-2

➤ If resistance values are good, go to step 6.

COMPONENT TESTING (continued) FOR SERVICE TECHNICIAN'S USE ONLY

- If any of the measurements do not match the values shown in the chart, check the harness of the suspected component between the CCU and door lock mechanism for continuity.
 - If the harness and connections are good, replace the door lock mechanism.
NOTE: To minimize risk of damage to door lock/switch wires, remove the door lock mechanism screws before removing the front panel.
6. If the preceding steps did not correct the lock problem, replace the CCU and retest door lock mechanism.
 - Unplug washer or disconnect power.
 - Replace the CCU.
 - Reassemble all parts and panels.
 - Perform the "Quick Diagnostic Test" to verify repair.

TEST #5: Drum Light (Steam Models)

This test is performed if the drum LED does not light.

1. On Whirlpool models, pressing the "Drum Light" button on the console should toggle the button indicator on and off.
 - If the button indicator does not turn on, go to TEST #2 – "Some buttons do not light indicators".
 - If the button indicator toggles on and off, go to step 2.
2. Unplug washer or disconnect power.
3. Remove the top panel to access CCU and user interface (UI).
4. Verify the drum light connector (P13) is securely connected to the UI.
5. Check harness and connections between the drum light and the UI.
 - If the connections are OK, go to step 6.
 - If not, repair or replace as needed.
6. Unplug the drum light connector (P13) from the UI.
7. Plug in washer or reconnect power.
8. On Whirlpool models, press the Drum Light button on the console until the button indicator is on. On Maytag models, press and hold the Steam for Stains/Drum Light button on the console to activate the LED circuit.
9. With a multimeter set to milliamps, measure the current across UI connector P13, pins 1

and 3. If the drum LED driver is working properly, you should measure 150–370 mA.

- If the current is present, replace the drum LED.
 - If the current is not present, replace the UI.
10. Unplug washer or disconnect power.
 11. Reassemble all parts and panels.

Water Level Controls

- ✓ Water Inlet Valves – Test #6
- ✓ Pressure Sensor/Switch – Test #7
- ✓ Drain Pump – Test #8
- ✓ Flow Meter – Test #9

TEST #6: Water Inlet Valves

This test checks the electrical connections to the valves and the valves themselves.

1. Check the relays and electrical connections to the valves by performing the "Quick Diagnostic Test". The following steps assume one or more of the valves did not turn on.
2. For the valve(s) in question, check the individual solenoid coils:
 - a. Unplug washer or disconnect power.
 - b. Remove top panel to access machine electronics.
 - c. Remove connector VCH7 from the CCU, and if a steam model, connector VSF2. Refer to CCU diagram.
 - d. Check harness connections to the solenoid valves. Verify continuity in harness between CCU and solenoid valves.
3. Check valve coil resistance at the valves, or across the following VCH7 and VSF2 connector pin-outs:

Valve	Pinout
Cold Fill Valve	VCH7, pins 1 & 2
Hot Fill Valve	VCH7, pins 3 & 4
Steam Valve *	VSF2, pins 1 & 2

* Steam model only

Resistance should be ~990 Ω.

- If resistance readings are tens of ohms outside the value or open, replace the valve assembly.
- If resistance readings are within range, reconnect VCH7 and, if applicable, VSF2 to CCU. Go to step 4.

COMPONENT TESTING (continued) FOR SERVICE TECHNICIAN'S USE ONLY

4. Plug in washer or reconnect power.
5. With a voltmeter set to **AC**, attach the leads across the pins of the suspect valve (see chart in step 3). Run the "Quick Diagnostic Test" and check for line voltage across the pins of the valve. **NOTE:** Refer to the "Quick Diagnostic Test" to determine when the cold, hot, and steam valves are actuated. (Example: Cold valve is actuated during test phase C02.)
 - If line voltage is present and valve still does not activate, replace valve assembly.
 - If line voltage is not present, replace the CCU.
6. Unplug washer or disconnect power.
7. Reassemble all parts and panels.
8. Perform the "Quick Diagnostic Test" to verify repairs.

TEST #7: Pressure Sensor/Switch

Pressure Sensor (Steam Models)

This test checks the pressure sensor, CCU, and wiring. **NOTE:** Usually, if the pressure sensor malfunctions, the washer will generate a long fill or long drain error.

1. Check the functionality of the pressure sensor by running a small load cycle. The valves should turn off automatically after sensing the correct water level in the tub. The following steps assume that this step was unsuccessful.

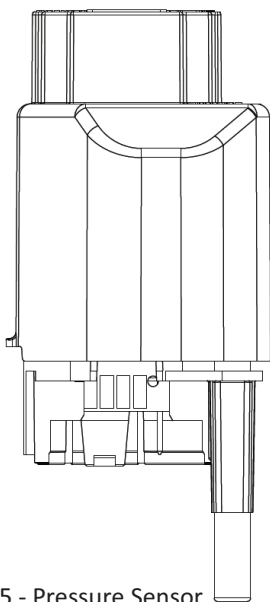

Figure 5 - Pressure Sensor

2. Press START/PAUSE to stop the cycle and then press POWER. The cycle will cancel and drain the water from the tub.
3. Unplug washer or disconnect power.
4. Remove top panel to access machine electronics. Pressure sensor is located at top right rear of cabinet.
5. Check hose connection between the pressure sensor and the pressure dome attached to the tub.
6. Check to ensure hose is routed correctly in the lower cabinet and not pinched or crimped.
7. Verify there is no water, suds, or debris in the hose or dome. Disconnect hose from pressure sensor and blow into hose to clear water, suds, or debris.
8. Check hose for leaks. Replace if needed.
9. Visually check that connector **PS8** is inserted all the way into the CCU (refer to CCU diagram). Also check that the pressure sensor harness is securely connected to the sensor.
10. Check the harness between the CCU and Pressure Sensor for continuity.
 - If there is continuity, go to step 11.
 - If there is no continuity, repair or replace as necessary.
11. Plug in washer or reconnect power.
12. With a voltmeter set to **DC**, connect black probe to CCU connector **PS8**, pin 8 (GND) and red probe to **PS8**, pin 4 (+5V [Vcc]).
 - If +5VDC is present, replace the pressure sensor.
 - If +5VDC is not present, perform TEST #1: CCU Power Check.
13. If the preceding steps did not correct the problem, replace the CCU.
 - Unplug washer or disconnect power.
 - Replace the CCU.
 - Reassemble all parts and panels.
 - Perform the "Quick Diagnostic Test" to verify repair.

COMPONENT TESTING (continued) FOR SERVICE TECHNICIAN'S USE ONLY

Pressure Switch (Non-Steam Models)

This test checks the pressure switch, CCU, and wiring. **NOTE:** Usually, if the pressure switch malfunctions, the washer will generate a long fill or long drain error.

1. Check the functionality of the pressure switch by running a small load cycle. The valves should turn off automatically after sensing the correct water level in the tub. The following steps assume that this step was unsuccessful.

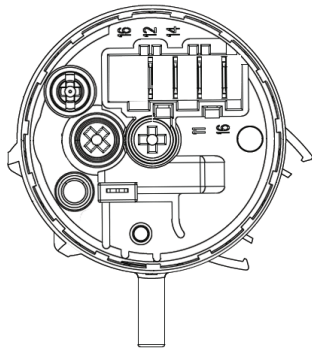

Figure 6 - Pressure Switch

2. Press START/PAUSE to stop the cycle and then press POWER. The cycle will cancel and drain the water from the tub.

3. Unplug washer or disconnect power.

4. Remove top panel to access machine electronics. Pressure switch is located at top right rear of cabinet.

5. Check hose connection between the pressure switch and the pressure dome attached to the tub.

6. Check to ensure hose is routed correctly in the lower cabinet and not pinched or crimped.

7. Verify there is no water, suds, or debris in the hose or dome. Disconnect hose from pressure switch and blow into hose to clear water, suds, or debris.

8. Check hose for leaks. Replace if needed.

9. Visually check that connector **PS8** is inserted all the way into the CCU (refer to CCU diagram). Also check that the pressure switch harness is securely connected to the switch.

10. Check the harness between the CCU and Pressure Switch for continuity.

- If there is continuity, go to step 11.
- If there is no continuity, repair or replace as necessary.

11. Disconnect **PS8** from the CCU and perform the continuity checks listed in the chart below. This check can also be performed at the pressure switch.

a. With no pressure to the switch, there should be continuity across **PS8**, pins 4 & 6 (switch pins 11 & 12).

b. Lightly blow into the pressure switch until a “click” is heard. Maintain that pressure and verify that there is continuity across **PS8**, pins 4 & 5 (switch pins 11 & 14).

c. Strongly blow into the pressure switch. Maintain that pressure and verify that there is continuity across **PS8**, pins 4 & 3 (switch pins 11 & 16).

➤ If the pressure switch passes the continuity check, go to step 12.

➤ If not, replace the pressure switch and perform step 1 to verify repair.

12. If the preceding steps did not correct the problem, replace the CCU.

➤ Unplug washer or disconnect power.

➤ Replace the CCU.

➤ Reassemble all parts and panels.

➤ Perform the “Quick Diagnostic Test” to verify repair.

Pressure Switch Continuity Check				
	Heater Trip	Wash Level	Vcc	Overflow
CCU PS8 Pinout	6	5	4	3
Press Sw Pinout	12	14	11	16
No Pressure	Closed	Open	Common	Open
Low Pressure	Open	Closed	Common	Open
High Pressure	Open	Closed	Common	Closed

COMPONENT TESTING (continued)

FOR SERVICE TECHNICIAN'S USE ONLY

TEST #8: Drain Pump

Perform the following checks if washer does not drain.

1. Check for obstructions in the usual areas. Clean and then perform step 2.
2. Check the drain pump and electrical connections by performing the "Quick Diagnostic Test". The following procedures assume that this step was unsuccessful.
 3. Unplug washer or disconnect power.
 4. Remove top panel to access machine electronics.
 5. Visually check that the DP2 connector is inserted all the way into the CCU. Refer to CCU diagram.
 - If visual check passes, go to step 6.
 - If connector is not inserted properly, reconnect DP2 and repeat step 2.
 6. Remove connector DP2 from the CCU. With an ohmmeter, measure the resistance across pins 1 and 2.
 7. Resistance should be approximately 16 Ω .
 - If the reading is infinite (open), go to step 8.
 - If the reading is correct, go to step 12.
 8. Remove the front panel to access drain pump. Verify pump is free from obstructions.
 9. Visually check the electrical connections at the drain pump.
 - If visual check passes, go to step 10.
 - If connections are loose, reconnect the electrical connections and repeat step 2.
 10. With an ohmmeter, check harness for continuity between the drain pump and CCU.
 - If there is continuity, go to step 11.
 - If there is no continuity, replace the lower machine harness and repeat step 2.
 11. With an ohmmeter, measure the resistance across the two pump terminals. Resistance should be approximately 16 Ω .
 - If the reading is infinite (open), replace the drain pump assembly.
 - If the reading is correct, go to step 12.

12. If the preceding steps did not correct the drain problem, replace the CCU.

- Unplug washer or disconnect power.
- Replace the CCU.
- Reassemble all parts and panels.
- Perform the "Quick Diagnostic Test".

TEST #9: Flow Meter (Steam Model)

This test checks the electrical connections to the flow meter and the flow meter itself.

1. Perform the "Quick Diagnostic Test". If error code F8E4 is generated, the washer is detecting less than 0.1L of water after 30 seconds of starting the test. Go to step 2.
 2. Did the valve(s) turn on and was water seen and heard entering the drum?
 - No, the valve(s) did not turn on. Go to TEST #6: Water Inlet Valves.
 - Yes, the valve(s) turned on, but no water entered the drum. Go to step 3.
 - Yes, the valve(s) turned on and water entered the drum. Go to step 4.
 3. Verify that the hot and cold water inlet hoses are properly connected to the washer and the valves are turned on fully. Ensure the inlet hoses are not kinked or inlet screens blocked.
 4. Unplug washer or disconnect power.
 5. Remove top panel to access machine electronics.
 6. Visually check that connector FM3 is inserted all the way into the CCU. Refer to CCU diagram.
 - If visual check passes, go to step 7.
 - If connector is not inserted properly, reconnect FM3 and repeat step 1.
 7. With an ohmmeter, check the harness between the CCU (FM3) and flow meter for continuity.
 - If there is continuity, go to step 8.
 - If there is no continuity, replace the flow meter harness.

COMPONENT TESTING (continued)

FOR SERVICE TECHNICIAN'S USE ONLY

8. With voltmeter set to DC, connect leads to FM3 pins 1 and 3. Run a wash cycle and measure the flow meter voltage when the inlet water valves open and water is entering the washer. A nominal reading of approximately 200mV should be measured when water is flowing through the flow meter (voltage will vary depending on household water pressure). No water flowing = 0V.

- If voltage is present, the flow meter is working properly. Go to step 9.
- If voltage is not present when water is entering the washer, replace the flow meter.

9. If the preceding steps did not correct the drain problem, replace the CCU.

- Unplug washer or disconnect power.
- Replace the CCU.
- Reassemble all parts and panels.
- Perform the "Quick Diagnostic Test" to verify repair.

Water Temperature Controls

- 3 Heating Element – Test #10
- 3 Temperature Sensor – Test #11

TEST #10: Heating Element

This test checks the heating element, wiring, and CCU.

1. Unplug washer or disconnect power.
2. Remove top panel to access machine electronics.
3. Disconnect connector HE2 from the CCU. Refer to CCU diagram.
4. Using an ohmmeter, measure the resistance across pins 1 and 2 of connector HE2
 - If the resistance is between 10-20Ω, the heating element and wiring are good; go to step 8.
 - If the resistance is open, go to step 5.
5. Access the heating element.
6. Disconnect the wire connectors from the heating element.
7. Using an ohmmeter, measure the resistance across the two heating element terminals.

- If the resistance is between 10-20 Ω, the heating element is good; replace the lower main harness.
 - If the resistance is open, replace the heating element.
8. If the preceding steps did not correct the heating element problem, replace the CCU.
- Unplug washer or disconnect power.
 - Replace the CCU.
 - Reassemble all parts and panels.
 - Perform the "Quick Diagnostic Test" to verify repair.

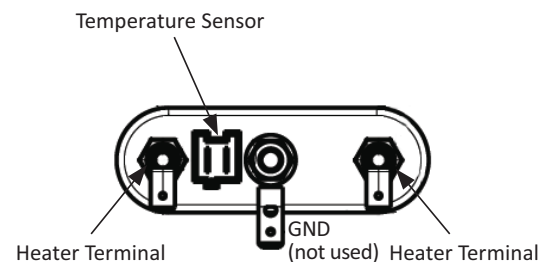

Figure 7 - Heater & Temperature Sensor

TEST #11: Temperature Sensor

This test checks the temperature sensor, wiring, and CCU.

1. Unplug washer or disconnect power.
2. Remove top panel to access machine electronics.
3. Disconnect connector SET2 from the CCU. Refer to CCU diagram.
4. Using an ohmmeter, measure the resistance across pins 1 and 2 of temperature sensor connector SET2. The measured resistance should be within the temperature range shown in the following table.

Approx. Temperature		Approx. Resistance
F°	C°	KΩ
32	0	35.9
50	10	22.8
68	20	14.8
86	30	9.8
104	40	6.6
122	50	4.6
140	60	3.2
158	70	2.3
176	80	1.7
194	90	1.3

COMPONENT TESTING (continued)

FOR SERVICE TECHNICIAN'S USE ONLY

- If the resistance is within the range shown in the table, go to step 8.
 - If the resistance is infinite or close to zero, go to step 5.
5. Remove the front panel to access the heating element.
 6. Disconnect the temperature sensor connector from the heating element.
 7. Using an ohmmeter, measure the resistance across pins 1 and 2 of the temperature sensor (on the heating element).
 - If the resistance is within the range shown in the table above, the sensor is good; replace the lower main harness.
 - If the resistance is open, replace the temperature sensor.
 8. If the preceding steps did not correct the temperature sensor problem, replace the CCU.
 - Unplug washer or disconnect power.
 - Replace the CCU.
 - Reassemble all parts and panels.
 - Perform the "Quick Diagnostic Test" to verify repair.

TEST #12: Dispenser

Distribution System

Perform the following checks if the washer will not dispense detergent, bleach, or fabric softener.

1. Check water supply to washer. Check water hose connections to and inside the washer.
2. Verify dispenser drawer is not clogged with detergent.
3. Unplug washer or disconnect power.
4. Remove the top panel to access the machine electronics.
5. Check the mechanical linkage from dispenser motor to top of dispenser.
6. Visually check that the DI6 connector is inserted all the way into the CCU. Refer to CCU diagram.
 - If visual check passes, go to step 7.
 - If connector is not inserted properly, reconnect DI6 and retest.

7. Remove connector DI6 from the CCU. With an ohmmeter, verify the resistance values shown below across the following DI6 connector pin-outs.

DISPENSER SYSTEM RESISTANCE			
Component	Resistance	Contacts Measured	
Dispenser Motor	1400-1600 ohms	DI6-1	DI6-2

- If the motor resistance is good, go to step 8.
 - If the measurement does not match the value shown in the chart, check the harness and connections between the CCU and dispenser motor for continuity. If the harness and connections are good, replace the dispenser motor.
8. Plug in washer or reconnect power. Run the "Quick Diagnostic Test". Between steps "C02" & "C03," observe that the dispenser motor changes the direction of the diverter valve from one position to another. Ex: Prewash (position 1) to Main Wash (position 2). Verify the motor has repositioned the valve and water is flowing into dispenser.
 - If the dispenser motor did not change the direction of the diverter valve, replace the motor.
 9. If the preceding steps did not correct the dispensing problem, replace the CCU and retest dispenser system.
 - Unplug washer or disconnect power.
 - Replace the CCU.
 - Reassemble all parts and panels.
 - Perform the "Quick Diagnostic Test" to verify repair.

COMPONENT TESTING (continued)

FOR SERVICE TECHNICIAN'S USE ONLY

Manually Unlocking the Door Lock System

1. Unplug washer or disconnect power.
2. Remove the top washer panel.
3. Reach down along the inside of the front (between tub and CCU) and locate the top of the door switch/lock assembly.
4. Located on the top of the door switch/lock assembly is a ring-shaped tab.
5. Gently pull the tab upward about ¼" or until a click is heard.
6. The door may be opened.

Component Removal

Components accessible through top panel:

Cycle Control Unit (CCU)
Pressure Sensor/Switch
Interference Filter
Water Valve Assembly
Flow Meter
Dispensing System
Dispenser Motor
User Interface/Console

Components accessible through back panel:

Drive Motor
Motor Control Unit (MCU)

Components accessible through front panel:

Door Lock/Switch Assembly
Drum Light
Drain Pump/Filter
Heater
Temperature Sensor

—NOTES—

DIAGNOSTICS & TROUBLESHOOTING

FOR SERVICE TECHNICIAN'S USE ONLY

DANGER



Electrical Shock Hazard

Only authorized technicians should perform diagnostic voltage measurements.

After performing voltage measurements, disconnect power before servicing.

Failure to follow these instructions can result in death or electrical shock.

WARNING



Electrical Shock Hazard

Disconnect power before servicing.

Replace all parts and panels before operating.

Failure to do so can result in death or electrical shock.

Voltage Measurement Safety Information

When performing live voltage measurements, you must do the following:

- Verify the controls are in the off position so that the appliance does not start when energized.
- Allow enough space to perform the voltage measurements without obstructions.
- Keep other people a safe distance away from the appliance to prevent potential injury.
- Always use the proper testing equipment.
- After voltage measurements, always disconnect power before servicing.

IMPORTANT: Electrostatic Discharge (ESD) Sensitive Electronics.

ESD problems are present everywhere. Most people begin to feel an ESD discharge at approximately 3000V. It takes as little as 10V to destroy, damage, or weaken the main control assembly. The new main control assembly may appear to work well after repair is finished, but a malfunction may occur at a later date due to ESD stress.

- Use an anti-static wrist strap. Connect wrist strap to green ground connection point or unpainted metal in the appliance

-OR-

Touch your finger repeatedly to a green ground connection point or unpainted metal in the appliance.

- Before removing the part from its package, touch the anti-static bag to a green ground connection point or unpainted metal in the appliance.
- Avoid touching electronic parts or terminal contacts; handle electronic control assembly by edges only.
- When repackaging main control assembly in anti-static bag, observe above instructions.

IMPORTANT SAFETY NOTICE — “For Technicians only”

This service data sheet is intended for use by persons having electrical, electronic, and mechanical experience and knowledge at a level generally considered acceptable in the appliance repair trade. Any attempt to repair a major appliance may result in personal injury and property damage. The manufacturer or seller cannot be responsible, nor assume any liability for injury or damage of any kind arising from the use of this data sheet.

DIAGNOSTICS & TROUBLESHOOTING FOR SERVICE TECHNICIAN'S USE ONLY

TROUBLESHOOTING GUIDE

PROBLEM	POSSIBLE CAUSE	CHECKS & TESTS
WON'T POWER UP • No operation • No keypad response • No LEDs or display	No power to washer	Check power at outlet, check circuit breakers, fuses, or junction box connections.
	Connection problem between AC plug and CCU	Check connections between the AC power cord and CCU for continuity.
	Connections between CCU and user interface	Check connections and continuity between CCU and UI.
	CCU problem	See TEST #1: CCU Power Check.
	User interface problem	See TEST #2: User Interface.
WON'T START CYCLE No response when Start Button is pressed.	Door lock mechanism not functioning	1. Door not closed due to interference. 2. Lock not closed due to interference. 3. See TEST #4: Door Lock System.
	Connections between CCU and UI	Check connections and continuity between CCU and UI.
	User interface problem	See TEST #2: User Interface.
	CCU problem	See TEST #1: CCU Power Check.
UI WON'T ACCEPT SELECTIONS	Connections between CCU and UI	Check connections and continuity between CCU and UI.
	User interface problem	See TEST #2: User Interface.
	CCU problem	See TEST #1: CCU Power Check.
DOOR WON'T LOCK	Door not closed	Ensure that door is completely closed.
	Door lock obstructed	Check mechanism for obstruction.
	Door lock mechanism not functioning	See TEST #4: Door Lock System.
DOOR WON'T UNLOCK	Reset washer	Unplug and reconnect the power cord. Wait 2 minutes to see if the washer door unlocks.
	Misaligned, broken, or over-tightened door latch	Check door lock mechanism and repair as necessary.
	Door lock mechanism not functioning	See TEST #4: Door Lock System.
WON'T DISPENSE	No water supplied to washer	1. Check water connections to washer. 2. Verify hot and cold supply is on.
	Dispenser clogged with detergent	Clean obstruction from dispenser.
	Valve problem	See TEST #6: Water Inlet Valves.
	Dispenser system problem	See TEST #12: Dispenser Distribution System.
WON'T FILL (Normal water level is only 2.5" to 5" [63.5 mm to 127 mm] inside tub.)	No water supplied to washer or low water pressure	1. Check water connections to washer. 2. Verify hot and cold supply is on.
	Plugged filter/screen	Check for plugged filter or screen in the water valve or hoses.
	Drain hose installation	Check for proper drain hose installation. Is water siphoning out of the drain hose?
	Valve problem	See TEST #6: Water Inlet Valves.
	Pressure sensor problem	See TEST #7: Pressure Sensor/Switch.
OVERFILLS	Drain hose/filter is plugged	Check for hose and drain filter obstructions.
	Valve(s) not shutting off	See TEST #6: Water Inlet Valves.
	Pressure sensor problem	See TEST #7: Pressure Sensor/Switch.
	Drain pump problem	See TEST #8: Drain Pump.
DRUM WON'T ROTATE	Is door lock showing open during the cycle?	See TEST #4: Door Lock System.
	Harness connections	Check harness connections between CCU > MCU > and drive motor.
	Motor problem	See TEST #3: Motor Circuit.
MOTOR OVERHEATS	Mechanical friction	Check for obstruction between spin basket and outer tub.
	Harness connections	Check harness connections between CCU > MCU > and drive motor.
	Motor problem	See TEST #3: Motor Circuit.

DIAGNOSTICS & TROUBLESHOOTING (continued) FOR SERVICE TECHNICIAN'S USE ONLY

TROUBLESHOOTING GUIDE (continued)

PROBLEM	POSSIBLE CAUSE	CHECKS & TESTS
WON'T DRAIN	Drain hose installation	Check for proper drain hose installation. Make sure it is not inserted more than 4.5" (113 mm).
	Plugged drain hose	Check drain hose for obstructions.
	Obstructions to drain pump	Check and clean drain filter for obstructions.
	Harness connections	Check harness connections between CCU and drain pump.
	Drain pump problem	See TEST #8: Drain Pump.
INCORRECT WATER TEMPERATURE	Water hose installation	Make sure inlet hoses are connected properly and valves are turned on fully.
	No hot water dispensed	Ensure that household hot water is present at tap. Minimum: 120°F (49°C)
	Heating element problem	See TEST #10: Heating Element.
	Temperature sensor problem	See TEST #11: Temperature Sensor.
LEAKING	Supply hose connections	Check hose connections and damaged rubber gasket due to over-tightening.
	Drain hose installation	Check for proper drain hose installation.
	Plugged drain hose	Check drain hose for obstructions.
	Overloading the washer	Overloading can partially push door open.
	Internal hose connections	Check internal hose connections for leakage.
	Check bellows	Remove, reposition, and reinstall the bellows. Make sure bellows is not wrinkled.
VIBRATION OR NOISE	Shipping kit not removed	Verify shipping bolts and spacers are removed.
	Washer not level	Level washer per installation instructions.
	Floor stability	Weak floors can cause vibration and walking of the washer.
	Rubber feet not installed	Install rubber feet on leveling legs.
	Leveling lock nuts not tightened	Tighten leveling lock nuts.
	High-pitched noise	May be caused by clogged inlet screens. Disconnect hoses and clean screens.
	Spring/damper installation	Check for proper spring and damper placement and installation.
	Hardware	Inspect panels for bending, warpage, or damage. Check for loose hardware.
POOR WASH PERFORMANCE Please reference Use & Care Guide	Oversuds	1. Verify use of HE detergent. 2. Excessive detergent usage. 3. Check drain hose and filter for obstructions.
	Incorrect water level	See "WON'T FILL".
	Clothes wet after cycle is complete	1. Single or tangled items in washer. 2. Oversuds (see above). 3. See "WON'T DRAIN", above.
	Load not rinsed	1. Check proper water supply. 2. Not using HE detergent. 3. Washer not loaded properly. 4. See TEST #6: Water Inlet Valves.
	Not cleaning clothes	1. Washer not loaded properly. 2. Not using HE detergent. 3. Not using correct cycle. 4. Not using dispensers.
	Fabric damage	1. Washer overloaded. 2. Bleach added incorrectly. 3. Sharp items in tub.
	Wrong option or cycle selection	Refer customer to "Use & Care Guide".

DIAGNOSTICS & TROUBLESHOOTING (continued) FOR SERVICE TECHNICIAN'S USE ONLY

FAULT/ERROR CODES — The fault codes below may be indicated under various conditions and can be accessed through Service Diagnostics.

Display	EXPLANATION AND RECOMMENDED PROCEDURE
SUDS	SUDS DETECTED
	<p>Fault is displayed when Suds prevent the basket from spinning up to speed or the pressure sensor detects rising suds level. The main control will flush water in attempt to clear Suds. If the water flush is unable to correct the problem, this may indicate:</p> <p>Possible Causes</p> <ul style="list-style-type: none"> • Not using HE detergent or excessive detergent usage. • Verify Bulk Dispensing setting. Make sure user has selected the right type of detergent and water hardness. • Check/clean drain pump filter and hose of foreign objects. • Ensure drain height does not exceed 8' (2.4 m) from washer base.
F0E1	LOAD DETECTED DURING THE WASHER CLEANING CYCLE
	<p>During the cleaning cycle, a load was detected inside the drum. Clear error code and run a Cleaning Cycle to verify problem.</p> <p>Possible Causes</p> <ul style="list-style-type: none"> • Load inside the washer during clean cycle. • Mechanical friction on drive mechanism or basket. (Clothing between basket and tub.)
F1E1	CCU ERROR
	<p>A communication error between the CCU and onboard EEPROM has occurred, or one of the main relays is not working properly.</p> <p>Possible Causes</p> <ul style="list-style-type: none"> • Check the electrical outlet for damage. • A power surge/drop may have caused this problem. Unplug or disconnect washer. Verify power at outlet (voltage, polarity, grounding, and dedicated circuit). Reconnect power and retest. • A relay on the CCU may be welded. <p>See TEST #1 (CCU/Power Check).</p>
F1E2	MCU ERROR - MULTIPLE RESETS
	<p>Motor Control Unit (MCU) has an internal malfunction, repeating under or over voltage, or over current conditions. Can also be caused by momentary loss of neutral feed to MCU during the spin cycle. If the error occurs during a high-speed spin, the door will remain locked for 3 minutes.</p> <p>Possible Causes</p> <ul style="list-style-type: none"> • See TEST #3 (Motor Circuit).
F2E3	UNSUPPORTED CYCLE
	<p>Cycle corruption or CCU is not compatible for this specific model of washer.</p> <p>Possible Causes</p> <ul style="list-style-type: none"> • Intermittent communication between CCU and UI. Check harness for continuity. • Rotate cycle selector knob and verify cycle information on console. CCU may be corrupted. • CCU is not compatible with washer—replace CCU.
F3E1	PRESSURE SWITCH / PRESSURE SENSOR ERROR
	<p>The CCU detects an out of range pressure signal. The use of analog pressure sensor or digital pressure switch is model dependent, but the procedure to detect this error does not change.</p> <p>Possible Causes</p> <ul style="list-style-type: none"> • Check pressure hose connection from tub to pressure sensor. Is hose pinched, kinked, plugged, or leaking air? • See TEST #7 (Pressure Sensor/Switch).
F3E2	TEMPERATURE SENSOR ERROR
	<p>This error is displayed if the water temperature sensor value is out of range (23°F to 217°F [-5°C to 103°C]). To find the correct ohm reading, refer to temperature chart. This error code is available only in service diagnostics.</p> <p>Possible Causes</p> <ul style="list-style-type: none"> • See TEST #11 (Temperature Sensor).
F5E1	DOOR SWITCH ERROR
	<p>This code is generated if the door has not been open for 3 consecutive cycles, or the door switch is open while the door is locked for more than 5 seconds. If this occurs during normal operation, the buzzer beeps 3 times. This error code is available only in service diagnostics.</p> <p>Possible Causes</p> <ul style="list-style-type: none"> • User presses START without closing door. • Door not open for 3 consecutive cycles. • Door switch mechanism damaged or obstructed. • See TEST #4 (Door Lock System).

DIAGNOSTICS & TROUBLESHOOTING (continued) FOR SERVICE TECHNICIAN'S USE ONLY

FAULT/ERROR CODES (continued) — The fault codes below may be indicated under various conditions and can be accessed through Service Diagnostics.

Display	EXPLANATION AND RECOMMENDED PROCEDURE
F5E2	DOOR LOCK ERROR
	At the start of a cycle, the washer attempts to lock the door 6 times. If door cannot be locked, the washer goes into pause mode and code is generated. This code is available only in service mode.
	Possible Causes <ul style="list-style-type: none"> • Door not completely closed due to interference. • Check door lock mechanism for damage, misalignment, or foreign objects. • See TEST #4 (Door Lock System).
F5E3	DOOR UNLOCK ERROR
	At the start of a cycle, the washer attempts to unlock the door 6 times. If door cannot be unlocked, the washer goes into pause mode and the code is generated. This code is available only in service diagnostics.
	Possible Causes <ul style="list-style-type: none"> • Verify door latch is secured to front panel. • Check for misaligned, broken, or over-tightened door latch. • See TEST #4 (Door Lock System).
F6E1	COMMUNICATION ERROR BETWEEN CCU AND MCU
	Communication between the Central Control Unit and the MCU has not been detected.
	Possible Causes <ul style="list-style-type: none"> • Check door switch operation. Faulty switch may interfere with power to MCU. • Check drive system for worn or faulty components. • Verify continuity in cable between CCU (MI3 & MS2) and MCU. See wiring diagrams. • See TEST #1 (CCU/Power Check). • See TEST #3 (Motor Circuit).
F6E2 F6E3	COMMUNICATION ERROR UI TO CCU COMMUNICATION ERROR CCU TO UI
	Communication between Central Control Unit (CCU) and User Interface (UI) has not been detected.
	Possible Causes <ul style="list-style-type: none"> • Verify continuity in cable between CCU (UI7) and UI (C2). See wiring diagrams. • Check AC and DC supplies. See TEST #1 (CCU/Power Check). • See TEST #2 (User Interface).
F7E1	DRIVE MOTOR TACHOMETER ERROR / WASHER OVERLOAD
	The MCU is unable to properly detect motor speed and the washer shuts down. If error occurs during high-spin, the door remains locked for 2-3 minutes.
	Possible Causes <ul style="list-style-type: none"> • Washer is overloaded. • Verify that the shipping system, including shipping bolts and spacers, is removed. • Mechanical friction – verify that drum rotates freely. • See TEST #3 (Motor Circuit).
F7E2	MCU FAULT OR MOTOR OVERHEAT
	The heat sink exceeds 212°F (100°C). If this occurs, CCU will reset the MCU and wait for the motor to cool down before restarting. This procedure can repeat up to 4 times before F7E2 is displayed.
	Possible Causes <ul style="list-style-type: none"> • Improper installation of washer. Ensure that washer is not located near a heat source and has proper ventilation. • Check that drum is not overloaded with clothes. • Mechanical friction – verify that drum rotates freely. • Check drive system for worn or faulty components. See TEST #3 (Motor Circuit).
F8E0	STEAM INLET VALVE ERROR (Not available on all models)
	This error is displayed when the steam valve malfunctions. This error can be seen only in service diagnostics.
	Possible Causes <ul style="list-style-type: none"> • Is water supply connected and turned on? • Check for blocked or kinked inlet hoses. • Low water pressure or blocked hose screens. • Check steam valve operation. See TEST #6 (Water Inlet Valves).

DIAGNOSTICS & TROUBLESHOOTING (continued) FOR SERVICE TECHNICIAN'S USE ONLY

FAULT/ERROR CODES (continued) —The fault codes below may be indicated under various conditions and can be accessed through Service Diagnostics.

Display	EXPLANATION AND RECOMMENDED PROCEDURE
F8E1	NO WATER DETECTED ENTERING WASHER OR PRESSURE SWITCH TRIP NOT DETECTED
	<p>The washer does not detect water input after 13 minutes of filling.</p> <p>Possible Causes</p> <ul style="list-style-type: none"> • Is water supply connected and turned on? • Check for blocked or kinked inlet hoses. • Low water pressure or blocked hose screens. • Check for proper drain hose installation. Is water siphoning out of the drain hose? Drain hose must not be more than 4.5" (113 mm) into drain pipe. • Check pressure hose connection from tub to pressure sensor. Is hose pinched, kinked, plugged, or leaking air? • See TEST #6 (Water Inlet Valves). • See TEST #7 (Pressure Sensor).
F8E2	DISPENSER SYSTEM ERROR
	<p>Dispenser motor is unable to reach the desired position.</p> <p>Possible Causes</p> <ul style="list-style-type: none"> • Check the mechanical linkage from dispenser motor to top of dispenser. • See TEST #12 (Dispenser Distribution System).
F8E3	OVERFLOW CONDITION
	<p>The overflow condition occurs if there is too much water or foam in the washer and the overflow contact on the pressure switch is closed for more than 60 seconds or 3 times during the same cycle. If overflow occurs, the valves are closed and the drain pump switches on for at least 30 seconds.</p> <p>Possible Causes</p> <ul style="list-style-type: none"> • Check inlet valves for proper shutoff. • Verify that drain hose is not plugged or kinked. • Check/clean drain pump filter of foreign objects. • Check pressure hose connection from tub to pressure sensor Is hose pinched, kinked, plugged, or leaking air? • See TEST #6 (Water Inlet Valves). • See TEST #7 (Pressure Sensor/Switch). • See TEST #8 (Drain Pump).
F8E4	FLOW METER FAULT
	<p>If less than 0.1L of water has entered the tub after 30 seconds from the start of the quick diagnostic routine, this error will be displayed. This error code is available only in service diagnostics.</p> <p>Possible Causes</p> <ul style="list-style-type: none"> • Is water supply connected and turned on? • Check for blocked or kinked inlet hoses. • See TEST #6 (Water Inlet Valves) . • See TEST #9 (Flow Meter) .
F9E1	LONG DRAIN
	<p>If the drain time exceeds 8 minutes without reaching reset level in pressure sensor, the valves are turned off and the drain pump will stop running. NOTE: Suds can cause delays in draining. Washer drains for 4 minutes, pauses 5 minutes, then tries again for 4 additional minutes of draining. F9E1 will display if washer does not drain. (Normal drain takes less than 2 minutes)</p> <p>Possible Causes</p> <ul style="list-style-type: none"> • Verify that the drain hose is not blocked or kinked. • Make sure drain hose is not sealed into drain pipe. • Make sure the drain hose height does not exceed 96" (2.4 m). • Check/clean drain pump filter of foreign objects. • Check pressure hose connection from tub to pressure sensor. Is hose pinched, kinked, plugged, or leaking air? • See TEST #8 (Drain Pump)19.

WIRING DIAGRAMS

WASHER NON-STEAM

Wiring Diagram – Non Steam

IMPORTANT: Electrostatic discharge may cause damage to machine control electronics. See page 1 for ESD information.

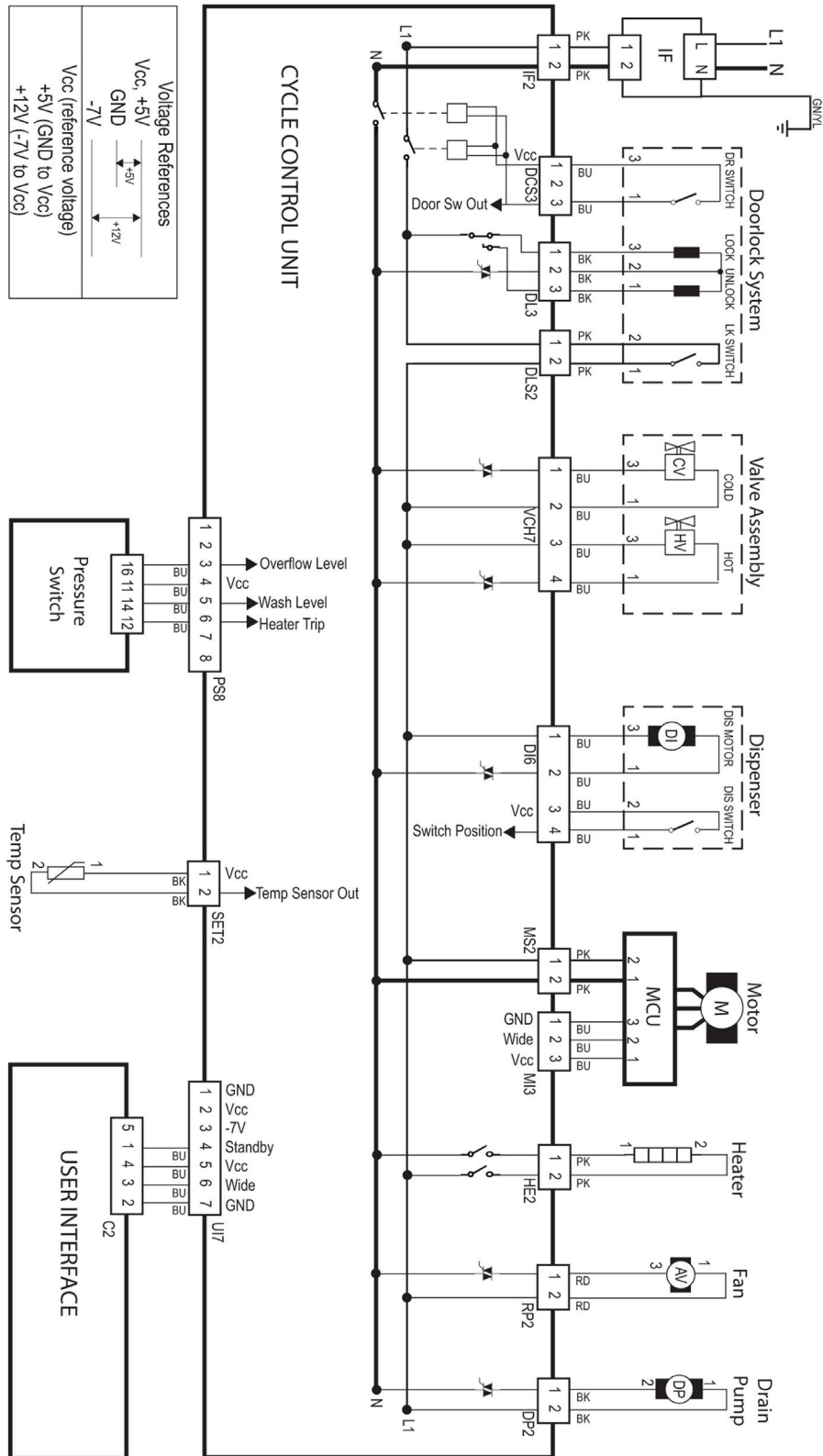

Figure 9 - Wiring Diagram – Non Steam

WIRING DIAGRAMS

WASHER STEAM

Wiring Diagram – Steam

IMPORTANT: Electrostatic discharge may cause damage to machine control electronics.

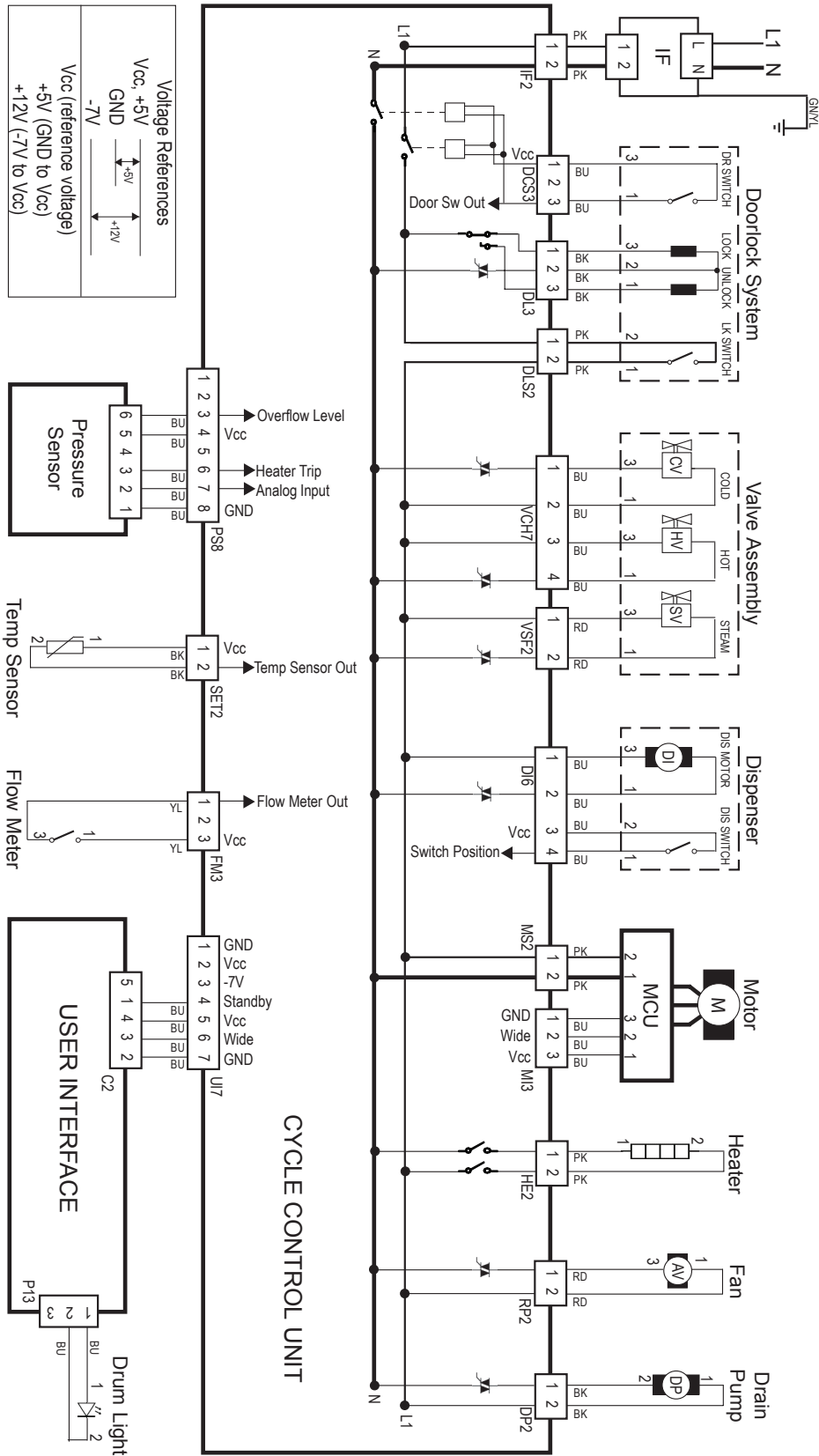

PRODUCT SPECIFICATIONS AND WARRANTY INFORMATION SOURCES

IN THE UNITED STATES:

FOR PRODUCT SPECIFICATIONS AND WARRANTY INFORMATION CALL:

FOR WHIRLPOOL PRODUCTS: 1-800-253-1301

FOR KITCHENAID PRODUCTS: 1-800-422-1230

FOR ROPER PRODUCTS: 1-800-447-6737

FOR TECHNICAL ASSISTANCE WHILE AT THE CUSTOMER'S HOME CALL:

THE TECHNICAL ASSISTANCE LINE: 1-800-832-7174

**HAVE YOUR STORE NUMBER READY TO IDENTIFY YOU AS AN
AUTHORIZED IN-HOME SERVICE PROFESSIONAL**

FOR LITERATURE ORDERS:

PHONE: 1-800-851-4605

FOR TECHNICAL INFORMATION AND SERVICE POINTERS:

www.servicematters.com

IN CANADA:

FOR PRODUCT SPECIFICATIONS AND WARRANTY INFORMATION CALL:

1-800-461-5681

FOR TECHNICAL ASSISTANCE WHILE AT THE CUSTOMER'S HOME CALL:

THE TECHNICAL ASSISTANCE LINE: 1-800-488-4791

**HAVE YOUR STORE NUMBER READY TO IDENTIFY YOU AS AN
AUTHORIZED IN-HOME SERVICE PROFESSIONAL**

