



U.S.A. Website: <http://us.lgservice.com>  
Canadian Website: <http://lg.ca>

# ELECTRIC & GAS DRYER SERVICE MANUAL

## CAUTION

READ THIS MANUAL CAREFULLY IN ORDER TO  
PROPERLY DIAGNOSE PROBLEMS AND TO SAFELY  
PROVIDE QUALITY SERVICE ON THESE DRYERS.

MODEL : DLE5001\*,DLE4901\*,DLG5002\*,DLG4902\*



OCT. 2009 PRINTED IN KOREA

P/No.: MFL62119914

## IMPORTANT SAFETY NOTICE

The information in this service guide is intended for use by individuals possessing skill and experience in electrical, electronic, and mechanical appliance repair. Any attempt to repair a major appliance may result in personal injury and property damage. The manufacturer or seller cannot be responsible for the interpretation of this information, nor can it assume any liability in connection with its use.

### **WARNING !**

*To avoid personal injury, disconnect power before servicing this product. If electrical power is required for diagnosis or test purposes, disconnect the power immediately after performing the necessary checks.*

## RECONNECT ALL GROUNDING DEVICES

If grounding wires, screws, straps, clips, nuts, or washers used to complete a path to ground are removed for service, they must be returned to their original position and properly fastened.

## WHAT TO DO IF YOU SMELL GAS:

- *Do not try to light a match, or cigarette, or turn on any gas or electrical appliance.*
- *Do not touch any electrical switches. Do not use any phone in your building.*
- *Clear the room, building or area of all occupants.*
- *Immediately call your gas supplier from a neighbor's phone. Follow the gas supplier's instructions carefully.*
- *If you cannot reach your gas supplier, call the fire department.*

## IMPORTANT

Electrostatic Discharge (ESD)  
Sensitive Electronics

**ESD problems are present everywhere. ESD may damage or weaken the electronic control assembly. The new control assembly may appear to work well after repair is finished, but failure may occur at a later date due to ESD stress.**

- Use an anti-static wrist strap. Connect wrist strap to green ground connection point or unpainted metal in the appliance.

- OR -

**Touch your finger repeatedly to a green ground connection point or unpainted metal in the appliance.**

- Before removing the part from its package, touch the anti-static bag to a green ground connection point or unpainted metal in the appliance.
- Avoid touching electronic parts or terminal contacts; handle electronic control assembly by edges only.
- When repackaging failed electronic control assembly in anti-static bag, observe above instructions.

---

# CONTENTS

1. SPECIFICATIONS .....	4
2. FEATURES AND BENEFITS .....	6
3. INSTALLATION INSTRUCTIONS .....	6
4. COMPONENT TESTING INFORMATION .....	11
5. MOTOR DIAGRAM AND SCHEMATIC .....	14
6. WIRING DIAGRAM .....	15
7. FLOW SENSOR FUNCTION.....	16
7-1. FLOW SENSOR .....	16
7-2. INSTALLATION CHECK .....	17
7-3. TROUBLESHOOTING FOR FLOW SENSOR DRYER .....	18
8. DIAGNOSTIC TEST .....	19
8-1. TEST 1 120V AC ELECTRICAL SUPPLY .....	20
8-2. TEST 2 THERMISTOR TEST - MEASURE WITH POWER OFF .....	23
8-3. TEST 3 MOTOR TEST .....	24
8-4. TEST 4 MOISTURE SENSOR .....	25
8-5. TEST 5 DOOR SWITCH TEST .....	26
8-6. TEST 6 HEATER SWITCH TEST - ELECTRIC TYPE .....	27
8-7. TEST 7 GAS VALVE TEST - GAS TYPE .....	28
8-8. TEST 8 SEMI-CONDUCTOR .....	29
8-9. TEST 9 MOTOR ASSEMBLY, DC, PUMP .....	29
9. CHANGE GAS SETTING (NATURAL GAS, PROPANE GAS) .....	30
10. DISASSEMBLY INSTRUCTIONS .....	32
11. EXPLODED VIEW.....	40
11-1. CONTROL PANEL & PLATE ASSEMBLY .....	40
11-2-1. CABINET & DOOR ASSEMBLY: ELECTRIC TYPE .....	41
11-2-2. CABINET & DOOR ASSEMBLY: GAS TYPE .....	42
11-3-1. DRUM & MOTOR ASSEMBLY: ELECTRIC TYPE .....	43
11-3-2. DRUM & MOTOR ASSEMBLY: GAS TYPE .....	44

# 1

## SPECIFICATIONS

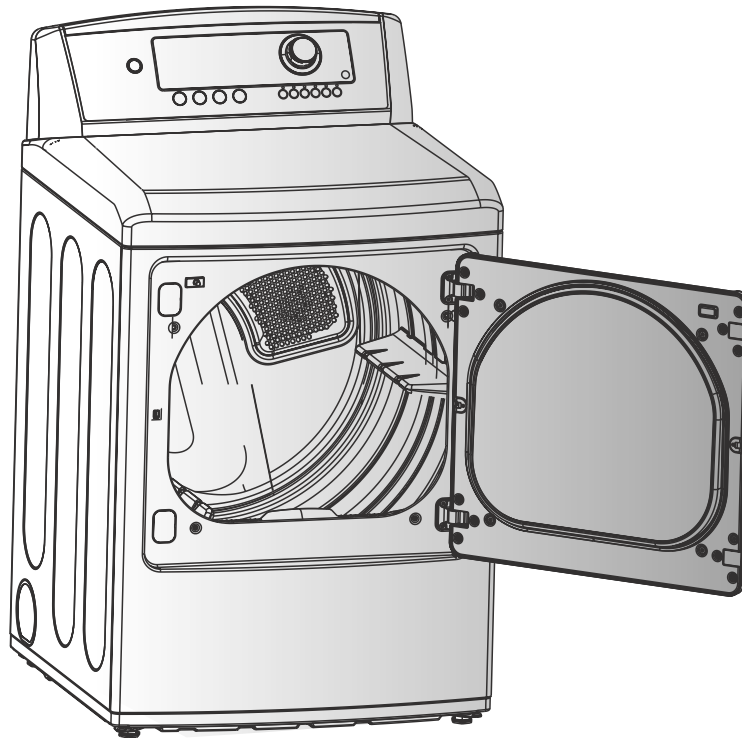

- Name: Electric and Gas Dryer
- Power supply : Please refer to the rating label regarding detailed information.
- Size : 27 X 28.9 X 45.3 (inch)
- Dryer capacity : IEC 7.3 cu.ft.
- Weight : 129.7 (lbs)

Specifications are subject to change by manufacturer.

## ■ ACCESSORIES

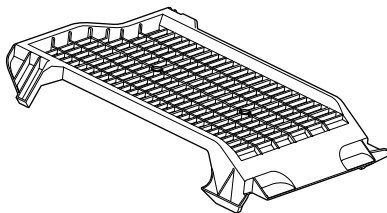

Dryer rack (1 each)

*See page 6 for how to use.*

ITEM		DLE5001*,DLE4901* DLG5002*,DLG4902*	REMARK
Material & Finish	Color	Blue White / Stainless Silver	
	Top Plate	Powder coating	
	Door Trim	Spray	
POWER SUPPLY		120V/240V 60Hz (26A)	
ELECTRICITY CONSUMPTION	MOTOR	250W (4.5A)	AC 120V
	HEATER	5400W (22.5A)	AC 240V(ELECTRIC MODEL)
	LAMP	15 W (0.2A)	AC 120V
	GAS VALVE	13 W (0.11A) x 2	AC 120V(GAS MODEL)
	AG HEATER	1100W (9.2A)	AC 120V(STEAM MODEL)
	DC, PUMP	2.4W (0.15A)	DC 9V(STEAM MODEL)
CONTROL TYPE		Electronic	
DRUM CAPACITY		7.3 cu.ft.	
Weight (lbs) – Net/Gross		129.7	
No. of Programs		12	
No. of Dry Options		6	
No. of Temperature Controls		5	
No. of Dry Levels		5	
Sound levels		3	
Sensor	Moisture	Available	Electrode sensor
	Temperature	Available	Thermistor
Reversible Door		Available	
Drum		Stainless Steel	
Dryer Rack		Available	
Child Lock		Available	
Interior Light		Available	
Product (WxHxD)		27" x 28.9 x 45.3 (inch)	
Packing (WxHxD)		29.8 x 31.3 x 47.24 (inch)	

# 2

## FEATURES AND BENEFITS

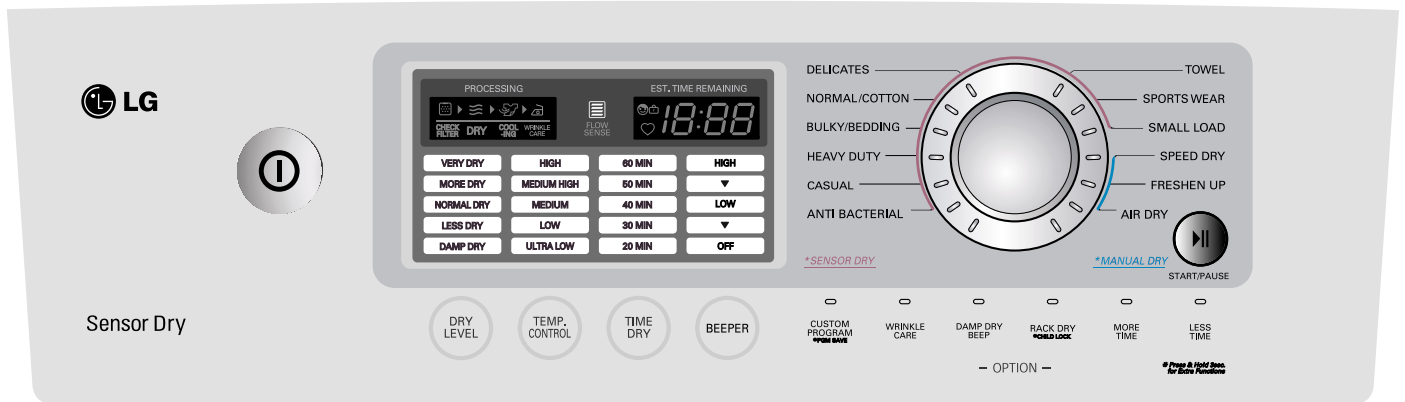

# 3

## INSTALLATION INSTRUCTIONS

### Dryer Rack Installation Instructions

- 1** Open the door. Hold the dryer rack with both hands.
- 2** Put the dryer rack into the drum.
- 3** Check and be sure that the front of the rack is properly seated behind the lint filter.

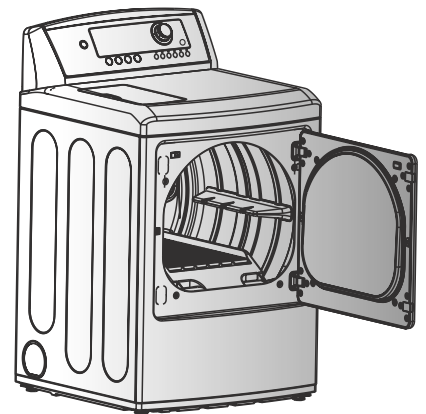
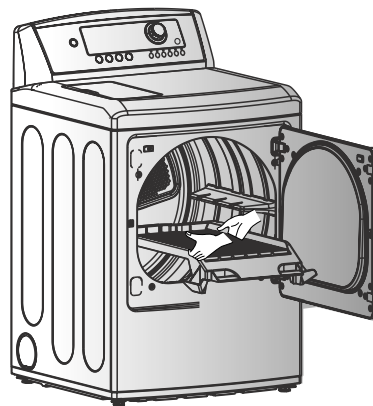
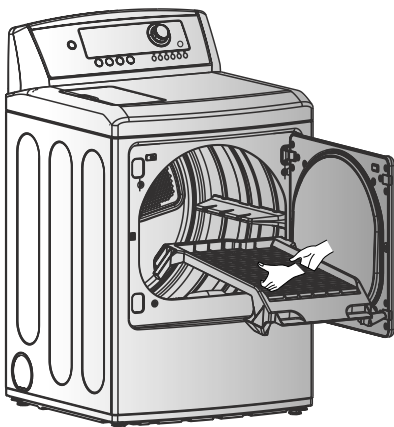

Review the following options to determine the appropriate electrical connection for your home:

	<b>4-wire receptacle (NEMA type 14-30R)</b>
--	---

Use the instructions under option 1 if your home has a 4-wire receptacle (NEMA type 14-30R).

	<b>3-wire receptacle (NEMA type 10-30R)</b>
--	---

Use the instructions under option 2 or 3 if your home has a 3-wire receptacle (NEMA type 10-30R). Use option 2 if local codes and ordinances permit the connection of a chassis ground to the neutral connector. If this is not permitted, use option 3.

	<b>4-wire direct</b>
--	----------------------

If this type is available at your home, you will be connecting to a fused disconnect or circuit breaker box

	<b>3-wire direct</b>
--	----------------------

If this type is available at your home, you will be connecting to a fused disconnect or circuit breaker box

### 4-wire connection : Direct wire

**Important :** Grounding through the neutral conductor is prohibited for (1) new branch-circuit installations, (2) mobile homes, and (3) recreational vehicles, and (4) areas where local codes prohibit grounding through the neutral conductor.

Prepare minimum 5ft(1.52m) of length in order for dryer to be replaced.

First, peel 5 inch (12.7cm) of covering material from end. Make a 5 inch of ground wire bared. After cutting 1½ inch (3.8cm) from 3 other wires, peel insulation back 1inch (2.5cm). Make ends of 3 wires a hook shape.

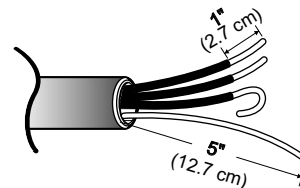

Then, put the hooked shape end of the wire under the screw of the terminal block (hooked end facing rightward) and pinch the hook together and screw tightly.

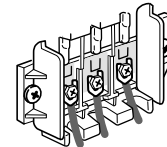

1. Connect neutral wire (white) of power cord to center terminal block screw.
2. Connect red and black wire to the left and right terminal block screws.
3. Connect ground wire (green) of power cord to external ground screw and move neutral ground wire of appliance and connect it to center screw.
4. Make sure that the strain relief screw is tightened, and be sure that all terminal block nuts are on tight and power cord is in right position.

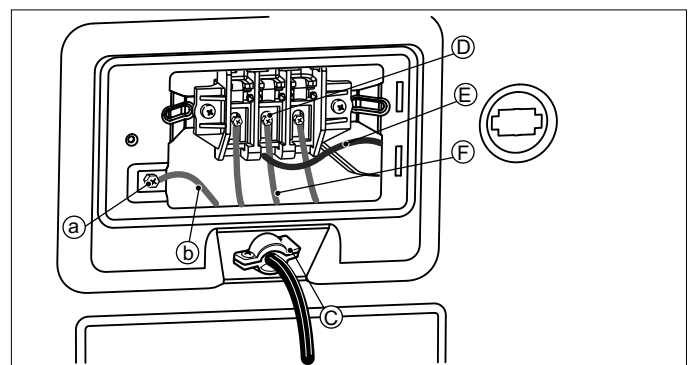

## 3-wire connection : Direct wire

**Important :** Grounding through the neutral conductor is prohibited for (1) new branch-circuit installations, (2) mobile homes, and (3) recreational vehicles, and (4) areas where local codes prohibit grounding through the neutral conductor.

Prepare minimum 5ft(1.52m) of length in order for dryer to be replaced.

First, peel 3 1/2 inch (8.9cm) of covering material from end and bare 1 inch from the ends.

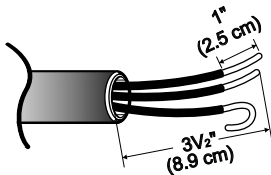

Then, put the hooked shape end of the wire under the screw of the terminal block (hooked end facing rightward) and pinch the hook together and screw tightly.

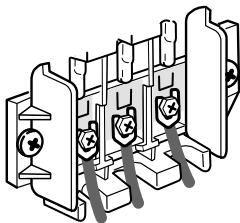

1. Connect neutral wire (white) of power cord to center terminal block screw.
2. Connect red and black wire to the left and right terminal block screws.
3. Make sure that the strain relief screw is tightened and be sure that all terminal block nuts are on tight and power cord is in right position.

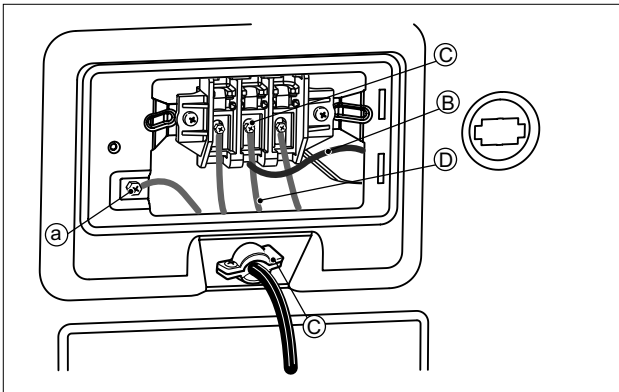

## Option 1: 4-wire connection with a Power supply cord.

✘ If your local codes or ordinances do not allow the use of a 3 wire connection, or you are installing your dryer in a mobile home, you must use a 4-wire connection.

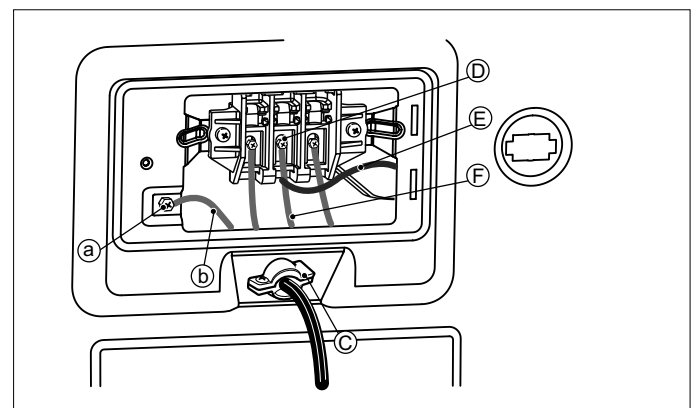
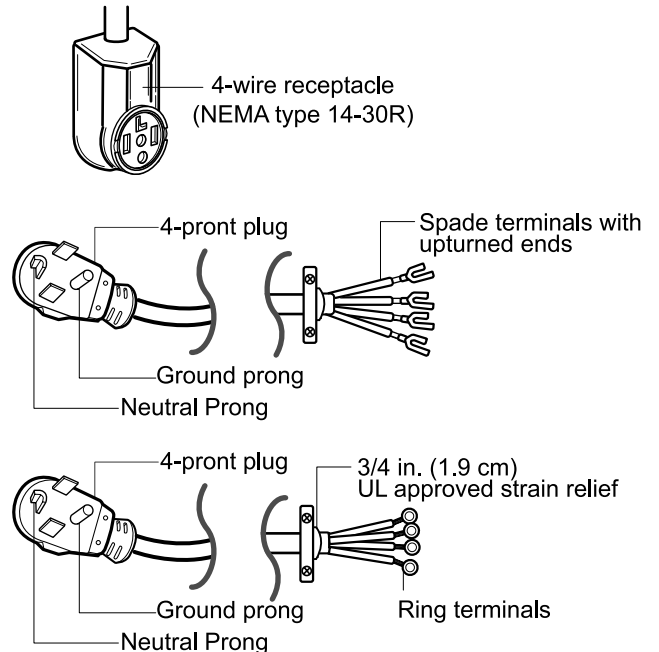

1. Connect the neutral wire (white) of the power cord to the center terminal block screw.
2. Connect the red and black wires to the left and right terminal block screws.
3. Connect the ground wire (green) of the power cord to the external ground screw. Remove the neutral ground wire of appliance and connect it to center screw.
4. Make sure that the strain relief screw is tightened and that all terminal block nuts are tight and the power cord is in the right position.

## Option 2: 3-Wire Connection with a Power Supply Cord

If your local codes or ordinances permit the connection of a frame-grounding conductor to the neutral wire, use these instructions. If your local codes or ordinances do not allow the connection of a frame-grounding conductor to the neutral wire, use the instructions under **Section 3: Optional 3-wire connection.**

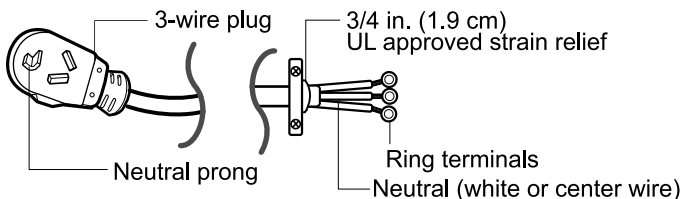
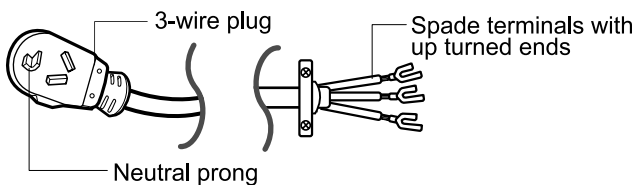
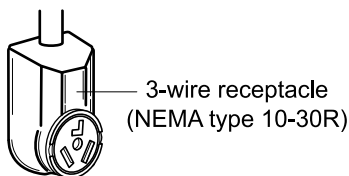

1. Connect the neutral (white or center) wire (B) to the center, silver colored, screw (A) and tighten securely.
2. Connect the other two power cord wires (red and black) to the left and right terminal block screws and tighten securely.
3. Tighten the strain relief screws (C) securely.

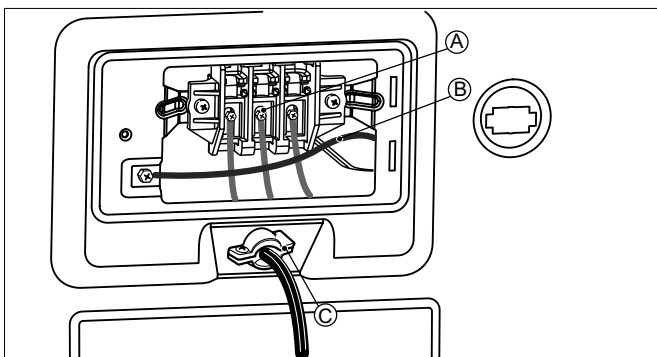

## Option 3: Optional 3-wire connection.

⚠ If your local codes or ordinances do not allow the connection of a frame-grounding conductor to the neutral wire, use the instructions under this section.

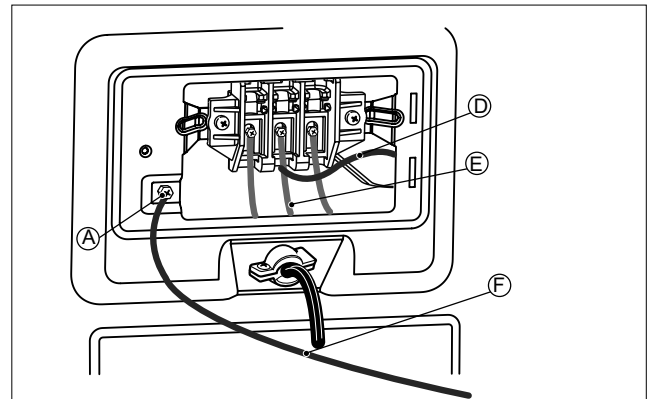
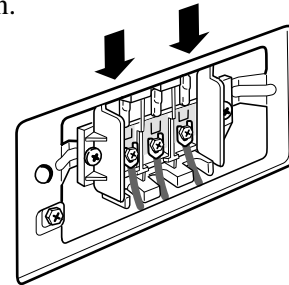

1. Remove the appliance ground wire (D) (green) from the external ground connector screw and reconnect it, together with the center, white, neutral wire (E) to the center, silver colored, terminal block screw.
2. Connect the other two power cord wires (red and black) to the left and right terminal block screws and tighten securely.
3. Tighten the strain relief screws securely.
4. Connect an independent ground wire (F) from the external ground connector screw to a proper ground. (The ground wire must be long enough to allow the appliance to be moved, if necessary, for service or cleaning.)

## 3-2. Connect Gas Supply Pipe (Gas Dryer ONLY)

For further assistance, refer to section on **Gas Requirements**.

1. Make certain your dryer is equipped for use with the type of gas in your laundry room. Dryer is equipped at the factory for Natural Gas with a 3/8" N.P.T. gas connection.
2. Remove the shipping cap from the gas connection at the rear of the dryer. Make sure you do not damage the pipe thread when removing the cap.
3. Connect to gas supply pipe using a new flexible stainless steel connector.
4. Tighten all connections securely. Turn on gas and check all pipe connections (internal & external) for gas leaks with a non-corrosive leak detection fluid.
5. For L.P. (Liquefied Petroleum) gas connection, refer to section on Gas Requirements.

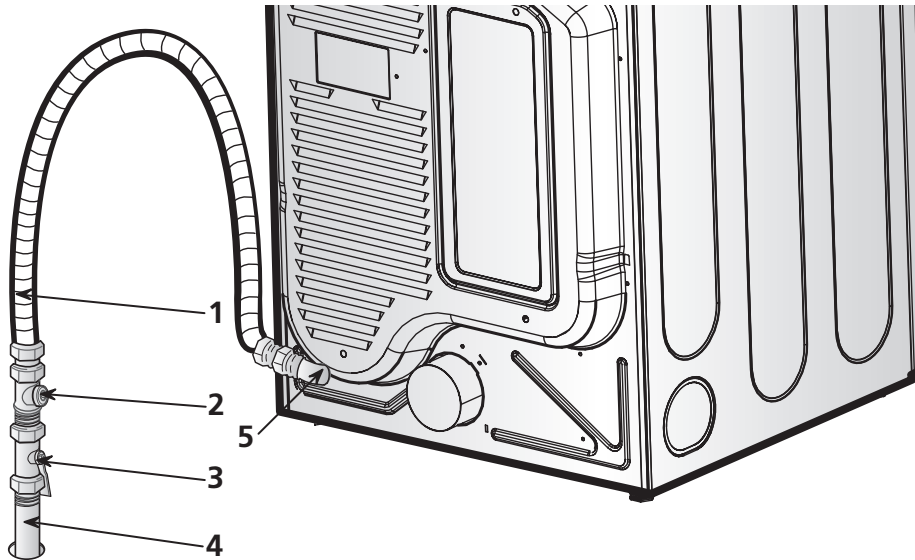

- 1 New Stainless Steel Flexible Connector - Use only if allowed by local codes (Use Design A.G.A. Certified Connector)
- 2 1/8" N.P.T. Pipe Plug (for checking inlet gas pressure)
- 3 Equipment Shut-Off Valve-Installed within 6' (1.8 m) of dryer



- 4 Black Iron Pipe  
Shorter than 20' (6.1 m) - Use 3/8" pipe  
Longer than 20' (6.1 m) - Use 1/2" pipe
- 5 3/8" N.P.T. Gas Connection

# 4

# COMPONENT TESTING INFORMATION

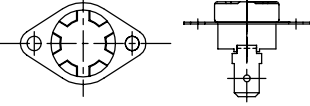
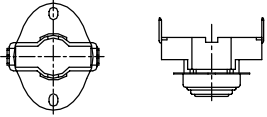
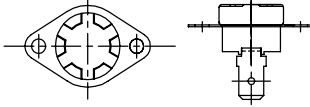
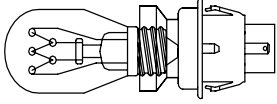
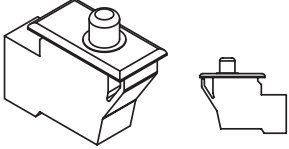
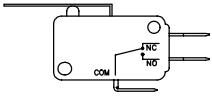
**⚠ CAUTION** When checking the Component, be sure to turn the power off, and do voltage discharge sufficiently.

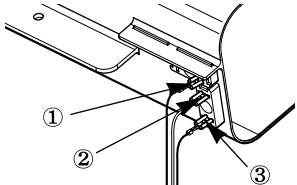
Component	Test Procedure	Check result	Remark
1. Thermal cut off  • Check Top Marking: N130	Measure resistance of terminal to terminal ① Open at $266 \pm 12^{\circ}\text{F}$ ( $130 \pm 7^{\circ}\text{C}$ ) ② Auto reset $31^{\circ}\text{F}$ ( $35^{\circ}\text{C}$ ) Same shape as Outlet Thermostat.	If thermal fuse is open must be replaced ① Resistance value $\approx \infty$ ② Continuity ( $250^{\circ}\text{F} \downarrow$ ) $< 1\Omega$	<ul style="list-style-type: none"> <li>• Heater case-Safety</li> <li>• Electric type</li> </ul>
2. Hi limit Thermostat (Auto reset) 	Measure resistance of terminal to terminal ① Open at $257 \pm 9^{\circ}\text{F}$ ( $125 \pm 5^{\circ}\text{C}$ ) ② Close at $221 \pm 9^{\circ}\text{F}$ ( $105 \pm 5^{\circ}\text{C}$ )	① Resistance value $\approx \infty$ ② Resistance value $< 5\Omega$	<ul style="list-style-type: none"> <li>• Heater case - Hi limit</li> <li>• Electric type</li> </ul>
3. Outlet Thermostat (Auto reset)  • Check Top Marking: N85	Measure resistance of terminal to terminal ① Open at $185 \pm 9^{\circ}\text{F}$ ( $85 \pm 5^{\circ}\text{C}$ ) ② Close at $149 \pm 9^{\circ}\text{F}$ ( $65 \pm 5^{\circ}\text{C}$ ) Same shape as Thermal cut off.	① Resistance value $\approx \infty$ ② Resistance value $< 5\Omega$	<ul style="list-style-type: none"> <li>• Blow housing - Safety</li> <li>• Electric type</li> </ul>
4. Lamp holder 	Measure resistance of terminal to terminal	Resistance value: $80\Omega \sim 100\Omega$	
5. Door switch 	Measure resistance of the following terminal 1) Door switch knob: open ① Terminal: "COM" - "NC" (1-3) ② Terminal: "COM" - "NO" (1-2) 2) Door switch push: push ① Terminal: "COM" - "NC" (1-3) ② Terminal: "COM" - "NO" (1-2)	① Resistance value $< 1\Omega$ ② Resistance value $\approx \infty$ ① Resistance value $\approx \infty$ ② Resistance value $< 1\Omega$	The state that Knob is pressed is opposite to Open condition.
6. Idler switch 	Measure resistance of the following terminal: "COM - NC"	1. lever open ① Resistance value $< 1\Omega$ 2. Lever push (close) ② Resistance value $\approx \infty$	

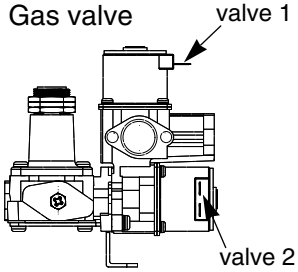
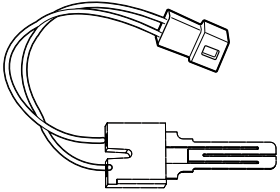
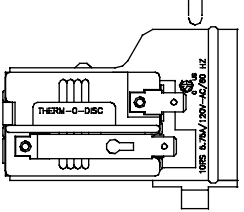
Component	Test Procedure	Check result	Remark
7. Heater 	Measure resistance of the following terminal ① Terminal: 1 (COM) - 2 ② Terminal: 1 (COM) - 3 ③ Terminal: 2 - 3	① Resistance value: 10 ② Resistance value: 10 ③ Resistance value: 20	<ul style="list-style-type: none"> <li>• Electric type</li> </ul>
8. Thermistor 	Measure resistance of terminal to terminal Temperature condition: 58°F ~ (10~40°C) 58°F ~ 104F (10~40°C)	Resistance value: 10	<ul style="list-style-type: none"> <li>• Heater case - Hi limit</li> <li>• Electric type</li> </ul>
9. Motor			<ul style="list-style-type: none"> <li>• See Page 13</li> </ul>
10. Gas valve 	Measure resistance of the following terminal ① Valve 1 terminal ② Valve 2 terminal	① Resistance value: > 1.5 k ② Resistance value: > 1.5~2.5 k	<ul style="list-style-type: none"> <li>• Gas type</li> </ul>
11. Igniter 	Measure resistance of terminal to terminal	Resistance value: 100~800	<ul style="list-style-type: none"> <li>• Gas type</li> </ul>
12. Frame Detect 	Measure resistance of terminal to terminal ① Open at 370°F ((Maximum) ② Close at 320°F	① Resistance value ② Resistance value < 1	<ul style="list-style-type: none"> <li>• Gas type</li> </ul>

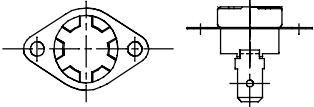
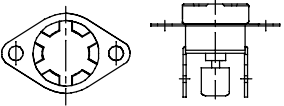
Component	Test Procedure	Check result	Remark
<p>13. Outlet Thermostat (Auto reset)</p>  <p>• Check Top Marking: N95</p>	<p>Measure resistance of terminal to terminal</p> <p>① Open at <math>203 \pm 7^{\circ}\text{F}</math> (<math>95 \pm 5^{\circ}\text{C}</math>)</p> <p>② Close at <math>158 \pm 9^{\circ}\text{F}</math> (<math>70 \pm 5^{\circ}\text{C}</math>)</p>	<p>① Resistance value <math>\neq \infty</math></p> <p>② Continuity <math>&lt; 1\Omega</math></p>	<ul style="list-style-type: none"> <li>• Gas type</li> <li>• Gas funnel</li> </ul>
<p>14. Outlet Thermostat (Manual reset)</p>  <p>• Check Top Marking: N100</p>	<p>Measure resistance of terminal to terminal</p> <p>① Open at <math>212 \pm 12^{\circ}\text{F}</math> (<math>100 \pm 7^{\circ}\text{C}</math>)</p> <p>② Manual reset</p>	<p>If thermal fuse is open must be replaced</p> <p>① Resistance value <math>\neq \infty</math></p> <p>② Continuity <math>&lt; 1\Omega</math></p>	<ul style="list-style-type: none"> <li>• Gas type</li> <li>• Gas funnel</li> </ul>

# 5

# MOTOR DIAGRAM AND SCHEMATIC

**NOTE** When checking Component, be sure to turn Power off, then do voltage discharge sufficiently.

■ Contact On / Off by Centrifugal Switch

Terminal No		①	②	③	④	⑤	⑥	Remark
Mode	Resistance							
Motor STOP	2 ~ 3Ω				●	●		Motor
	≒ ∞	●	●					Heater (Electric Models)
	≒ ∞			●			●	Gas Valve (Gas Models)
Motor RUN	3 ~ 5Ω				●	●		Motor
	< 1Ω	●	●					Heater (Electric Models)
	< 1Ω			●			●	Gas Valve (Gas Models)

..... Open  
 ——— Close

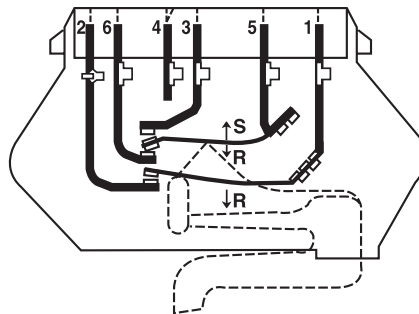

SWITCH SHOWN IN START POSITION

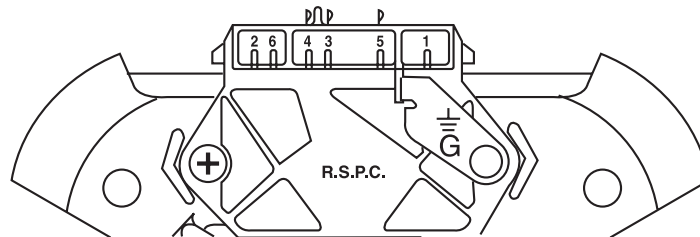

■ STOP MODE  
 (When Motor does not operate)

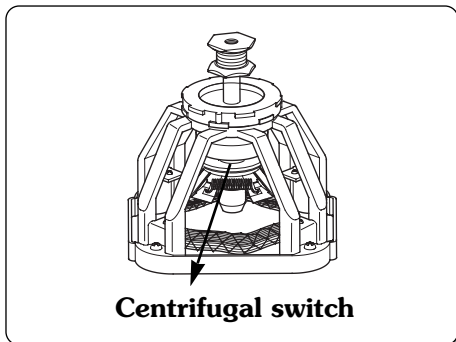

■ RUN MODE  
 (Motor operates)

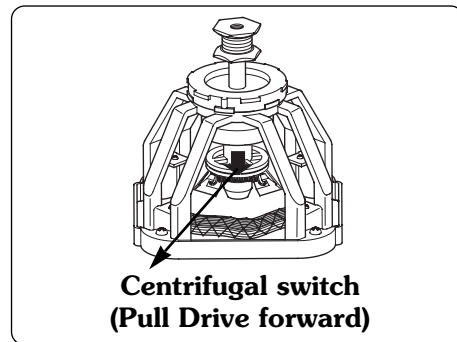

# 6

# WIRING DIAGRAM

## ELECTRIC DRYER WIRING DIAGRAM

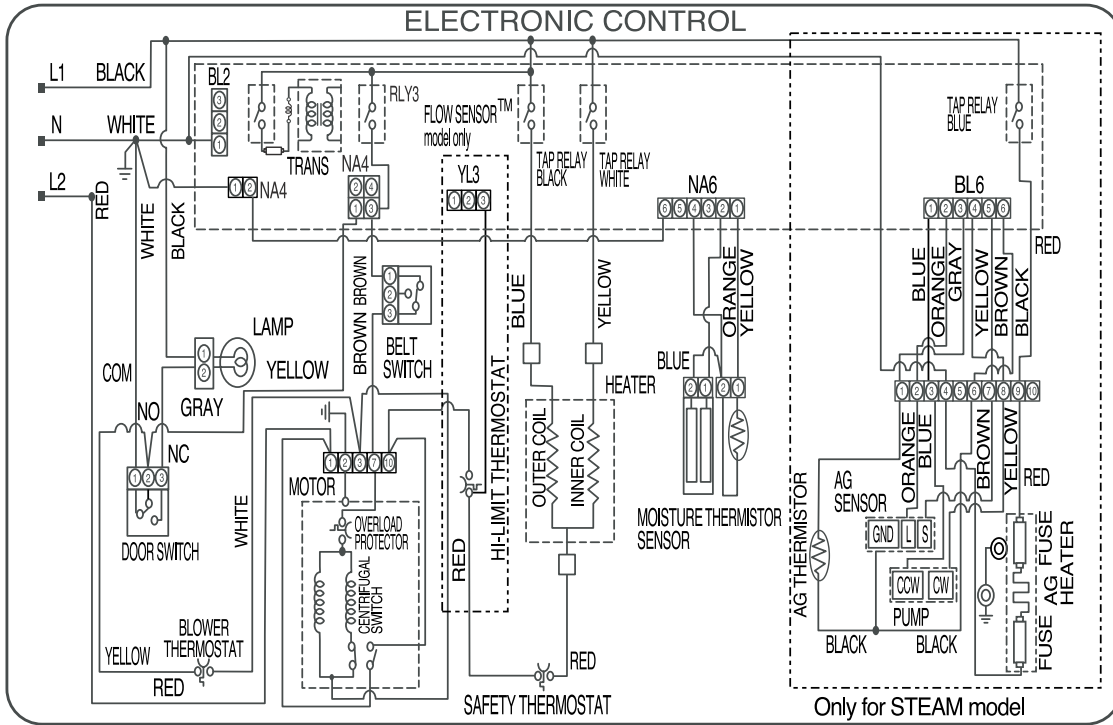

## GAS DRYER WIRING DIAGRAM

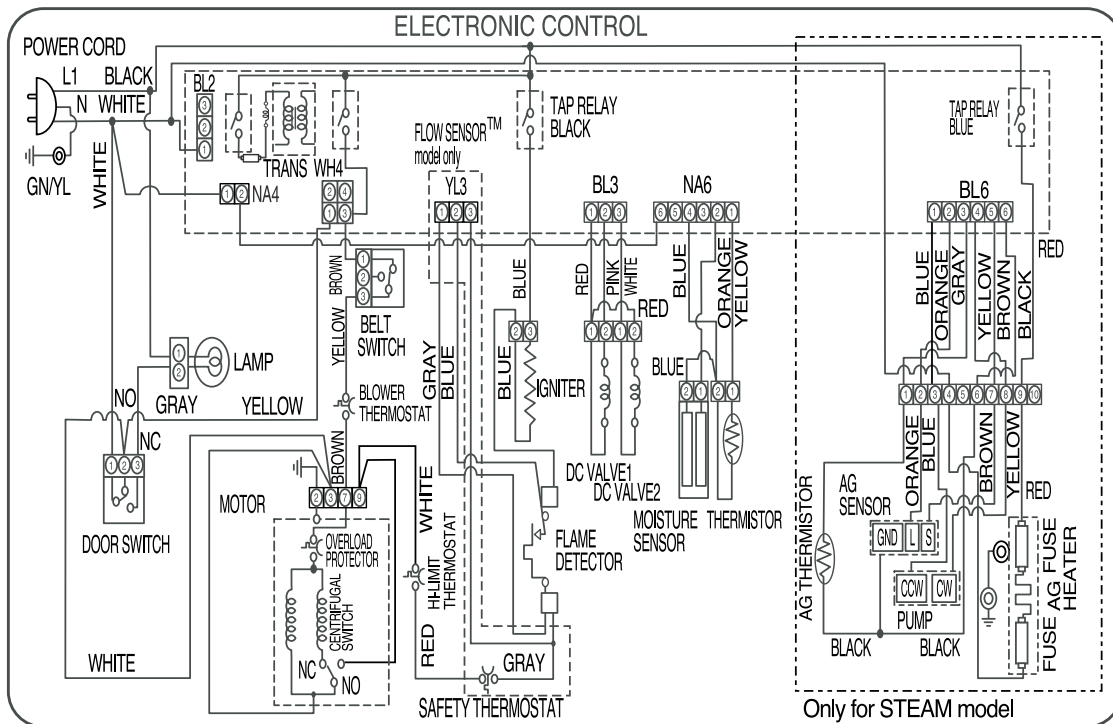

# 7

## FLOW SENSOR FUNCTION

### 7-1 Flow sensor

This FlowSense™ function detects the clogging or blocking of ducts.

“Clogged” duct vents or hoses decrease efficiency in drying cloths. Clogged vents can also cause fire.

This function alarms you, when to clean the ducts.

When the alarm about Duct clogging is on display of the panel, your duct vents should be cleaned by yourself or serviceman.

#### Flow Sensor Function

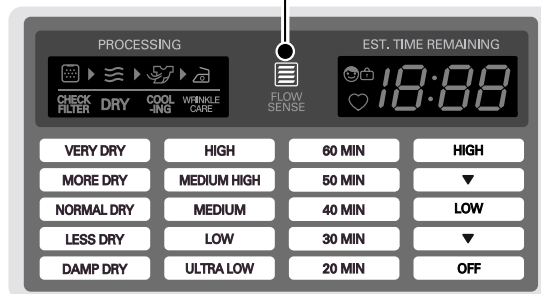

## 7-2 Installation check

This feature allows you to quickly verify that the exhaust system is adequate for the normal function of the dryer. The check takes only two minutes. The results of the check are displayed in the FlowSense display window as shown below

(Fig. 1). The dryer must be at room temperature for this test to be reliable. To perform this test, start the machine in standby mode (power off). Press and hold both the **DAMP DRY BEEP** and the **TEMP CONTROL** buttons together while turning on the dryer with the **POWER** button i.e. Press together the three buttons **DAMP DRY BEEP + TEMP CONTROL + POWER**. The dryer will start and run for 2 minutes while it checks temperatures. At the end of this short cycle, it will display the results as follows.

Fig.1

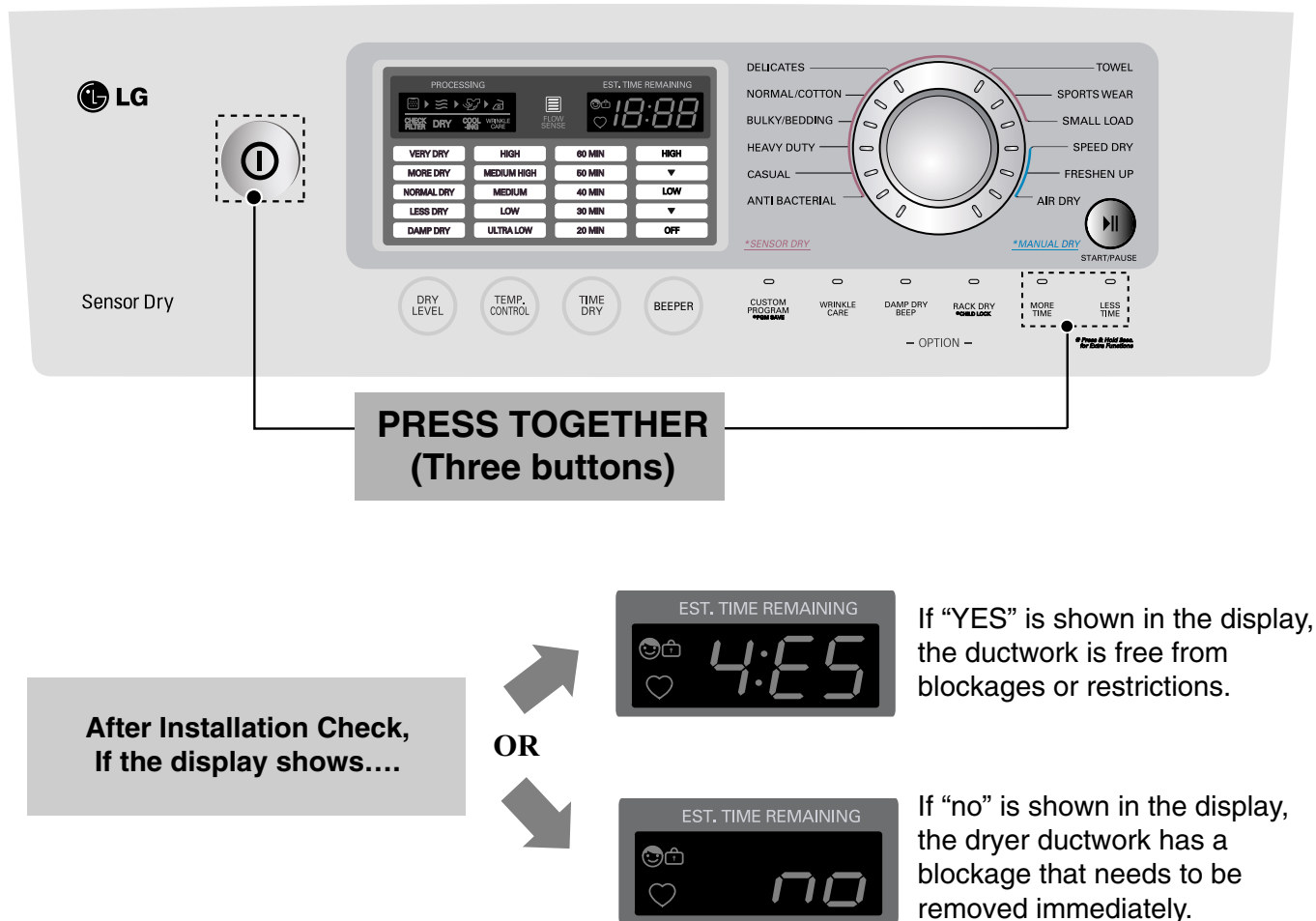

## 7-3 Troubleshooting for flow sensor dryer

### 1. FLOW SENSE indicator light is on

Is Lint Filter full?



Clean lint filter before every load



Is Duct clogged?



Check & clean duct.

### 2. FLOW SENSE indicator light is on and does not disappear.

1. FLOW SENSE indicator light is on even when vents have been clean and even when the vents are off.  
 → **This is Normal.** After Flow sensor Recheck Full Next Cycle, Flow sensor is Reset.  
 (Flow sensor bars will disappear after Dryer has operated two cycle)

### ■ Displayed and Don't disappear Bars

\*Control Panel

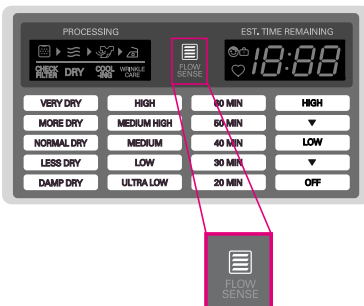

Make sure that the ductwork is not crushed or restricted.

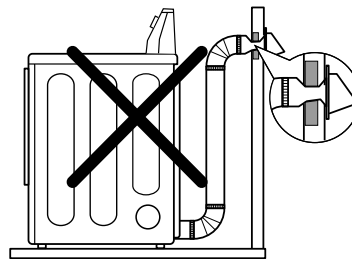

Avoid long runs of ducts or runs with multiple elbows or bends.

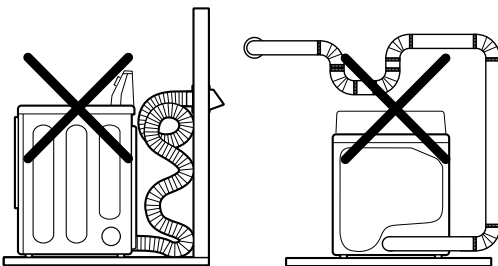

Check for blockages and lint build up.

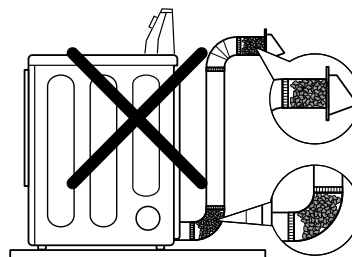

1. This TEST should be used for Factory test /Service test. Do not use this DIAGNOSTIC TEST other than specified.
2. Activating the Heater manually with the Door open may trip the Thermostat attached to the Heater, therefore do not activate it manually. (Do not press the door switch to operate the heater while the door is open )

### ■ ACTIVATING THE DIAGNOSTIC TEST MODE

1. UNIT must be in standby (unit plugged in, display off)
2. Press POWER while pressing MORE TIME and LESS TIME simultaneously.
3. Press START/PAUSE button to advance through diagnostics.

Pressing the START/PAUSE	CHECKING ACTION	DISPLAY	CHECKPOINT
None	Electric control & Temperature sensor	8E9(Elec Type) 898(Gas Type)	Standard
		V00	PGM Ver (8E8-V008E8)
		tE1	Thermistor open
		tE2	Thermistor shorted
		tE4	AG Thermistor open or shorted
Once	Motor+Controller	30 = Low moisture 239 = High moisture	Motor runs Displays Moisture Sensor Operation : If moisture sensor is contacted with damp cloth. The display number is below 180 in normal condition
Twice	<ul style="list-style-type: none"> <li>■ ELECTRIC TYPE Motor+Heater1(2700W)</li> <li>■ GAS TYPE Motor+Gasvalve</li> </ul>	Current Temp. (5~70)	<ul style="list-style-type: none"> <li>■ ELECTRIC TYPE Heater 1 is energized - 2700 W</li> <li>■ GAS TYPE Valve runs (Temperature in the drum is displayed in degrees C.)</li> </ul>
3 times	<ul style="list-style-type: none"> <li>■ ELECTRIC TYPE Motor+Heater1+Heater2 (5400W)</li> <li>■ GAS TYPE Motor+Gasvalve</li> </ul>	Current Temp. (5~70)	<ul style="list-style-type: none"> <li>■ ELECTRIC TYPE: Heater 1 and heater 2 are energized - 5400 W</li> <li>■ GAS TYPE: Gas valve is energized (Temperature in the drum is displayed in degrees C.)</li> </ul>
4 times	Motor+Pump+ Heater2(runs for 1sec) (Heater1 off)	Pump AD valve (11~255)	Pump runs
		E5	Pump Error
5 times	Motor,Pump,Heater2 off	OO	
6 times	Loads, Controller off		Power off

\* To check pump operation:

When pressed 4 times in the test mode, If the AD value of the pump is higher than 10 on the display, the pump is normal. If it is lower than 10, E5 error will be displayed.

## ■ Test 1 120V AC Electrical supply

<b>Caution</b>	When measuring power, be sure to wear insulated gloves, to and avoid an electric shock.	
<b>Trouble Symptom</b>	No power was applied to Controller. (LED,LCD Display off)	
<b>Measurement Condition</b>	With Dryer Power On; Connector linked to Controller.	
	<p>Check the outlet, is the voltage 110V ~ 125V AC?</p> <p><b>NO</b></p> <ul style="list-style-type: none"> <li>• Check the fuse or circuit breaker.</li> </ul> <p><b>YES</b></p>	
	<p>Check if the voltage measured between Connector BK2 or WH2-② (Black Wire) Linked to the Controller and WH1-① (White Wire) Is 110~125V?</p> <p><b>NO</b></p> <ul style="list-style-type: none"> <li>• Check if Power Cord is properly connected.</li> </ul> <p><b>YES</b></p>	
	<p>① Check if the Controller wire is disconnected.</p> <p>② Check if Terminal Block and Power Cord are connected (Check Plug ). - Does Power Cord N (Natural) line match to Terminal Center N (Natural) line?</p> <p><b>NO</b></p> <ul style="list-style-type: none"> <li>• Reconnect the controller.</li> </ul> <p><b>YES</b></p>	
	<p>Replace controller.</p>	

<b>Caution</b>	When measuring power, be sure to wear insulated gloves, to and avoid an electric shock.
<b>Trouble Symptom</b>	Check the Tab Relays Connection properly.
<b>Measurement Condition</b>	With Dryer Power On; Connector linked to Controller.

### 1. Power Connection

< Table1 > : Connection of the Tab Relay with Heater (Elec)

	Tab Relay 1	Tab Relay 2	Heater 1	Heater 2	Remark
High Mid High Medium	on	on	on	on	Temperature Control below $68 \pm 4^{\circ}\text{C}$ . Turn on Heater1 and Heater2.
Low Extra Low	on	off	on	off	Temperature Control below $52 \pm 4^{\circ}\text{C}$ . Only Turn on Heater1.

< Table 2 > : Connection of the Tab Relay with Burner (Gas)

	Tab Relay 1	Burner	Remark
High Mid High Medium	○	○	Temperature Control below $70 \pm 4^{\circ}\text{C}$ . Turn on Burner
Low Extra Low	○	○	Temperature Control below $47 \pm 4^{\circ}\text{C}$ . Turn on Burner

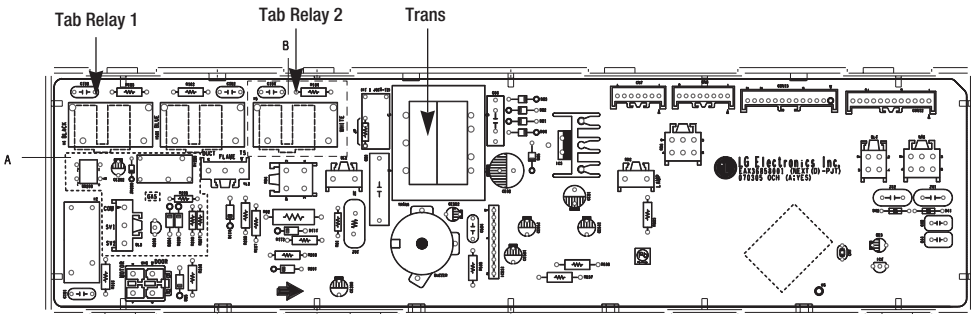

\* PCB ASSEMBLY LAYOUT

### 2. Status Mode Of The Connection

< Table1 > : Connection of Tab Relay with the Tab Relay of the PCB ASSEMBLY (Elec)

	Color	Connection		Remark
		Harness	PCB	
Connector Housing	Black			Check the Matching color Between Harness wire and Tab Relay. (Black Housing – Black Tab Relay)
	White			

< Table 2 > : Connection of Tab Relay with PCB ASSEMBLY (Gas)

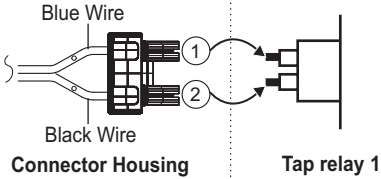
	Color	Harness	PCB	Remark
Connector Housing	Black			Check the Matching color Between Harness wire and Tab Relay. (Black Housing – Black Tab Relay)

### 3. Status Mode Of wrong Connection

< Table1 > : Wrong Connection of the Tab Relay and Connector Housing (Elec)

Items	Case	Heater1 Operation(black)	Heater2 operation(White)	PCB condition Of operation
1.Black and White Housing	Wire ①, ② CROSS	Off	Off	Power Off
2.Black Housing	Wire ①, ② CROSS	Off	Off	Power Off
3.White Housing	Wire ①, ② CROSS	Normal	Normal	Power On
* 4.Black and White Housing	Housing CROSS	Heater2	Heater1	Power On
5.Black and White Housing	Housing and Wire ①, ② CROSS	Off	Off	Power Off

< Table2 > : Wrong Connection of the Tab Relay and Connector Housing (Gas)

Items	Case	Heater1 Operation(black)	Heater2 operation(White)	PCB condition Of operation
1.Black and White Housing	Wire ①, ② CROSS	Off	Off	Power Off

### ⚠ CAUTION

- In case of power failure(<Table1>-1,2,5,<Table2>-1), Please check the Connection of "2.Status Table of Connection".  
 In case of power failure(<Table1>-4), please check the Connection of "2. Status Table of Connection". Because improper Connection of the equipment-dryer can be damaged of changing heater.

## ■ Test 2 Thermistor Test --- Measure with Power Off

<b>Caution</b>	Before measuring resistance, be sure to turn Power off, and do voltage discharge. (When discharging, contact the metal plug of Power cord with the Ground.)
<b>Trouble Symptom</b>	<ol style="list-style-type: none"> <li>① During Diagnostic Test, tE1 and tE2 Error occur.</li> <li>② During operation, Heater would not turn off, or remains on.</li> <li>③ Difference between actual and sensed temperature is significant.</li> </ol>
<b>Measurement Condition</b>	After turning Power off, measure the resistance.

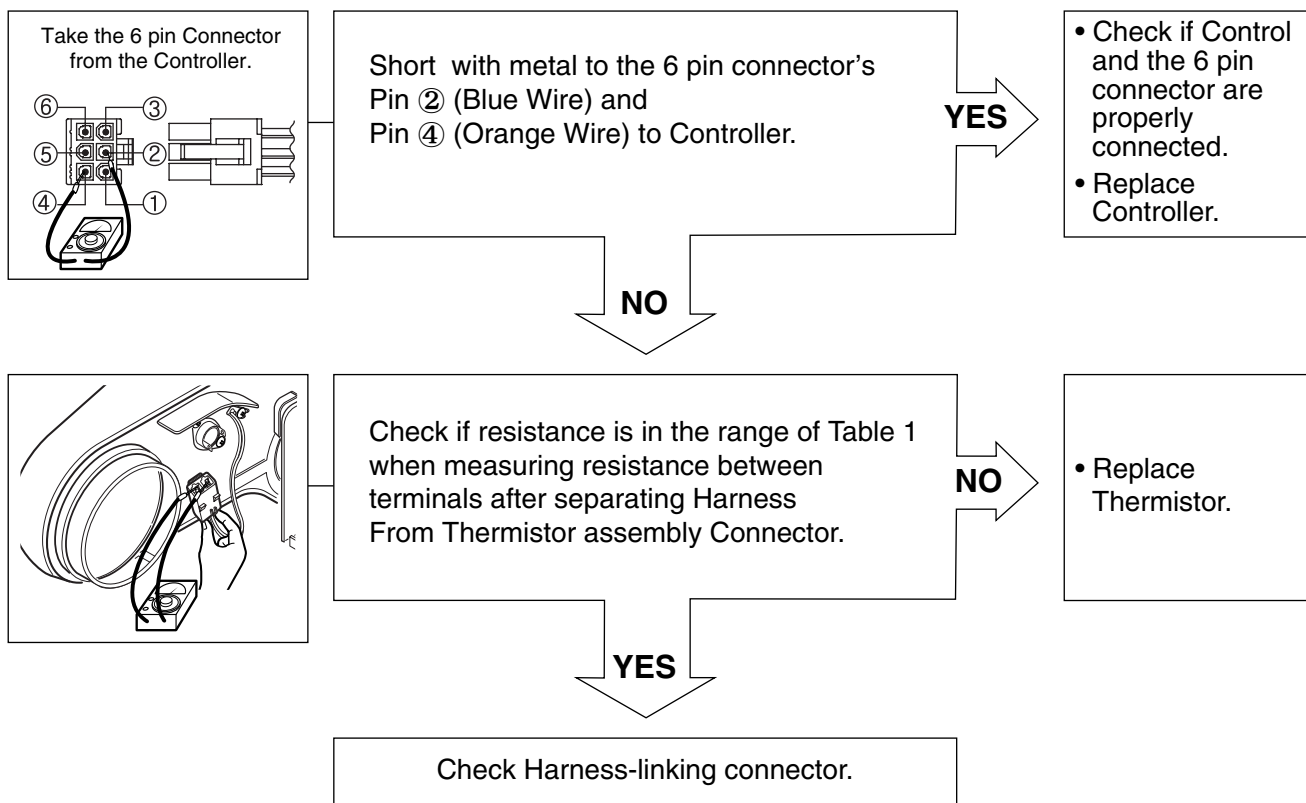

■ Table 1. Resistance for Thermistor Temperature.

Air TEMP.[°F (°C)]	RES. [kΩ]	Air TEMP.[°F (°C)]	RES. [kΩ]	Air TEMP.[°F (°C)]	RES. [kΩ]
50°F (10°C)	18.0	90°F (32°C)	7.7	130°F (54°C)	2.9
60°F (16°C)	14.2	100°F (38°C)	6.2	140°F (60°C)	3.0
70°F (21°C)	11.7	110°F (43°C)	5.2	150°F (66°C)	2.5
80°F (27°C)	9.3	120°F (49°C)	4.3	160°F (71°C)	2.2

## ■ Test 3 Motor test

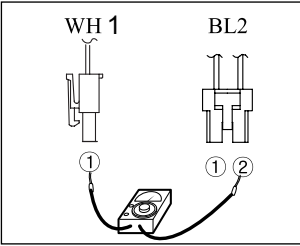
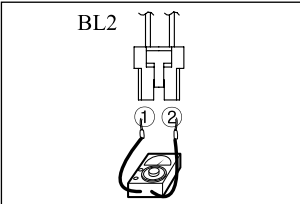
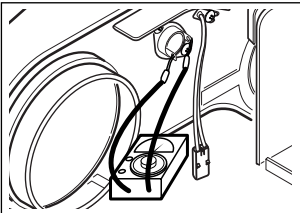
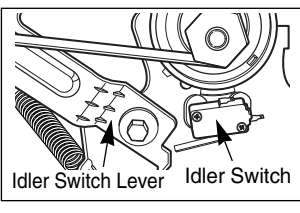
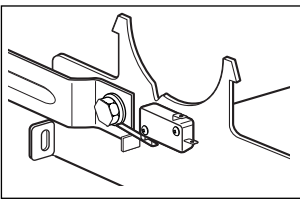
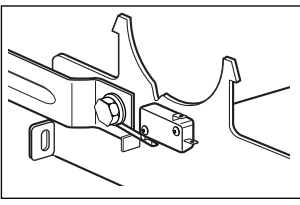
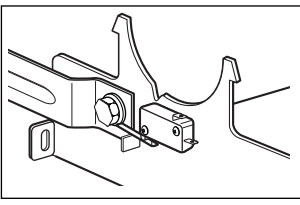
<p><b>Caution</b></p>	<p>Before measuring resistance, be sure to turn Power off, and do voltage discharge. (When discharging, contact the metal plug of Power cord with earth line.)</p>	
<p><b>Trouble Symptom</b></p>	<p>Drum will not rotate; No fan will function; No Heater will work.</p>	
<p><b>Measurement Condition</b></p>	<p>Turn the Dryer's Power Off, then measure resistance.</p>	
	<p>Is resistance below <math>3\Omega</math> between Connector WH① (White wire) and BL2-② (Brown wire)? ※ Measure while door is closed.</p>	<p><b>YES</b></p> <ul style="list-style-type: none"> <li>• Replace Control. (Relay check)</li> <li>• Check Controller connector.</li> </ul>
	<p>Is resistance below <math>3\Omega</math> between Connector WH① (White wire) and BL2-① (Yellow wire)? ※ Measure while door is closed.</p>	<p><b>NO</b></p> <ul style="list-style-type: none"> <li>• Check if Door flame presses door switch knob.</li> <li>• Check Door Switch.</li> <li>• Check Harness connection.</li> </ul>
	<p>Is resistance below <math>3\Omega</math> between Connector BL2-① (Yellow wire) and BL2-② (Brown wire)?</p>	<p><b>YES</b></p> <ul style="list-style-type: none"> <li>• Replace Control. (Relay check)</li> <li>• Check Controller connector.</li> </ul>
	<p>Is resistance below <math>1\Omega</math> between terminals of Outlet Thermostat attached to blower housing?</p>	<p><b>NO</b></p> <ul style="list-style-type: none"> <li>• Replace Outlet</li> <li>• Thermostat. (Refer to 'Component')</li> </ul>
	<p>Does Idle Switch attached to Motor Bracket operate Level by drum belt? (Not operating Lever is normal.)</p>	<p><b>YES</b></p> <ul style="list-style-type: none"> <li>• Check Idler Assembly.</li> <li>• Drum Belt cuts off</li> <li>• Drum Belt takes off from Motor Pulley.</li> </ul>
	<p>Is resistance below <math>1\Omega</math> between Idler Switch terminals?</p>	<p><b>NO</b></p> <ul style="list-style-type: none"> <li>• Replace Idler Switch.</li> </ul>
	<p><b>YES</b></p> <ul style="list-style-type: none"> <li>• Check Motor. (Refer to 'Motor Diagram &amp; Check')</li> <li>• Check if Control Connector is contacted.</li> </ul>	

## ■ Test 4 Moisture sensor

<b>Caution</b>	Before measuring resistance, be sure to turn Power off, and do voltage discharge. (When discharging, contact the metal plug of Power cord with earth line.)
<b>Trouble Symptom</b>	Degree of dryness does not match with Dry Level.
<b>Measurement Condition</b>	Turn the Dryer's Power Off, then measure resistance.

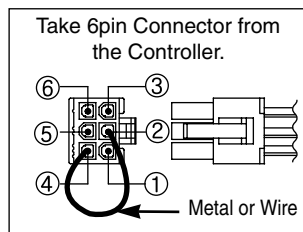

Short with metal to the 6 pin connector's Pin ② (Blue Wire) and Pin ④ (Orange Wire) to Controller.

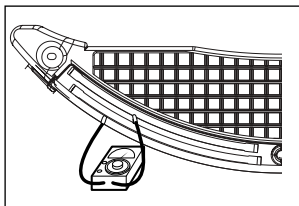

When measuring resistance in Electric load, is resistance below 1Ω?

**NO**

Check Electro Load and Harness Connector.  
Check Harness-linking connector.

**YES**

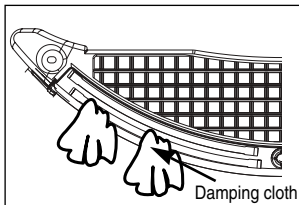

When contacting cloth to Electro load:  
1. Is the measurement within the range of Table 2 during Diagnostic Test?  
2. Is the measurement within the range of Table 2 when measuring the voltage in the 6 pin connector's Pin ③ (BLUE wire) and Pin ⑤ (ORANGE wire)?

**NO**

Replace Control and Check.

**YES**

Normal Condition

■ Table 2. IMC Ratio and Display Value / Voltage (IMC: Initial Moisture Content)

IMC	Display Value	Voltage (DC) (between 6 Pin terminal ③,⑤)	Remark
70% ~ 40%	50 ~ 130	2.5V	Weight after removing from Washing Machine
40% ~ 20%	130 ~ 20	2.0V ~ 4.0V	Damp Dry
10% ~ Dried clothes	205 ~ 240	Over 4.0V	Completely-dried clothes

## ■ Test 5 Door switch test

<p><b>Caution</b></p>	<p>Before measuring resistance, be sure to turn Power off, and do voltage discharge. (When discharging, contact the metal plug of Power cord with earth line.)</p>
<p><b>Trouble Symptom</b></p>	<p>Door Opening is not sensed.(During operation, when opening Door, Drum motor and Heater run continuously) Door Close is not sensed. (Drum motor will not operate. Display will flash at 0.5 second intervals.)</p>
<p><b>Measurement Condition</b></p>	<p>After turning Dryer Power Off, measure resistance.</p>
<div style="display: flex; flex-direction: column; align-items: flex-start;"> <div style="display: flex; width: 100%; margin-bottom: 20px;"> <div style="width: 25%; text-align: center;"> <p>BK2 WH1</p> </div> <div style="width: 50%; padding: 0 10px;"> <p>Measure while Door is closed. Check it resistance is below 2500 Ω between WH1-①(White wire) and BK2-② Connector WH1,BL2 after taking WH1,BL2 out from Controller.</p> </div> <div style="width: 20%; text-align: center;"> <p>YES</p> </div> </div> <div style="display: flex; width: 100%; margin-bottom: 20px;"> <div style="width: 25%; text-align: center;"> <p>NO</p> </div> <div style="width: 50%; padding: 0 10px;"> <p>Measure while Door is open. Check it resistance is 300~60 Ω between WH1-①(White wire) and BK2-② (Black wire). Connector WH1,BL2 after taking WH1,BL2 out from Controller.</p> </div> <div style="width: 20%; text-align: center;"> <p>NO</p> </div> </div> <div style="display: flex; width: 100%; margin-bottom: 20px;"> <div style="width: 25%; text-align: center;"> <p>WH 1 BL2</p> </div> <div style="width: 50%; padding: 0 10px;"> <p>Measure while Door is open. Check it resistance is below 1 Ω between BL2- ①(Yellow wire) and WH1-①(White wire) after taking Connector WH1,BL2 out from Controller.</p> </div> <div style="width: 20%; text-align: center;"> <p>YES</p> </div> </div> <div style="display: flex; width: 100%; margin-bottom: 20px;"> <div style="width: 25%; text-align: center;"> <p>NO</p> </div> <div style="width: 50%; padding: 0 10px;"> <p>Measure while Door is closed. Check it resistance is below 1 Ω between BL2- ①(Yellow wire) and WH1-①(White wire) after taking Connector WH1,BL2 out from Controller.</p> </div> <div style="width: 20%; text-align: center;"> <p>NO</p> </div> </div> <div style="width: 100%; text-align: center; margin-bottom: 20px;"> <p>YES</p> </div> <div style="width: 100%; text-align: center;"> <p>Check Controller. Check Harness-linking connector.</p> </div> <div style="display: flex; justify-content: space-between; margin-top: 20px;"> <div style="width: 45%;"> <ul style="list-style-type: none"> <li>• Door switch Check (Refer to Component testing.)</li> </ul> </div> <div style="width: 45%;"> <ul style="list-style-type: none"> <li>• Check Lamp. (When opening Lamp, replace then measure again.)</li> <li>• Door switch Check(Refer to Component testing.)</li> </ul> </div> </div> <div style="display: flex; justify-content: space-between; margin-top: 20px;"> <div style="width: 45%;"> <ul style="list-style-type: none"> <li>• Door switch Check (Refer to Component testing.)</li> </ul> </div> <div style="width: 45%;"> <ul style="list-style-type: none"> <li>• Door switch Check (Refer to Component testing.)</li> </ul> </div> </div> </div>	

## ■ Test 6 Heater switch test - Electric Type

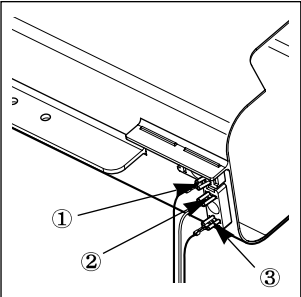
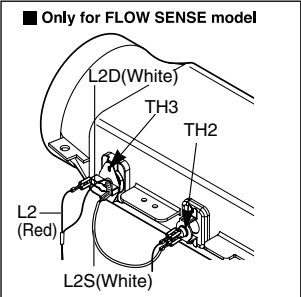
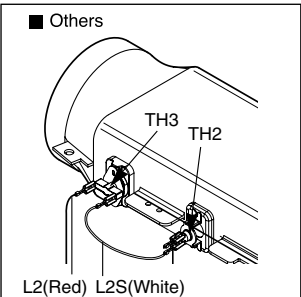
<b>Caution</b>	Before measuring resistance, be sure to turn Power off, and do voltage discharge. (When discharging, contact the metal plug of Power cord with earth line.)	
<b>Trouble Symptom</b>	While operating, Heating will not work. Drying time takes longer.	
<b>Measurement Condition</b>	After turning Power off, measure the resistance.	
  <p>■ Only for FLOW SENSE model</p>  <p>■ Others</p> <p>※ Wires          • L2(Red)          • L2D(White) : Go to the duct (YL3 in main pcb)          • L2S(White) : Go to the safety.</p>	<p>1. Is resistance between Heater terminal ① and ② below 18 ~ 22Ω?          2. Is resistance between Heater terminal ① and ③ below 18 ~ 22Ω?          3. Is resistance between Heater terminal ② and ③ below 9 ~ 11Ω?</p> <p><b>NO</b></p> <p><b>YES</b></p> <p>Check if the value of measured resistance is below 1Ω between terminal TH2 (Safety Thermostat).</p> <p><b>NO</b></p> <p><b>YES</b></p> <p>Check if the value of measured resistance is below 1Ω between terminal TH3 (HI-Limit Thermostat).</p> <p><b>NO</b></p> <p><b>YES</b></p> <p>Check Motor. Check if the value of measured resistance is below 1Ω between terminal ① and ⑩ at RUN condition.</p> <p><b>NO</b></p> <p><b>YES</b></p> <p>Check Controller. Check Harness-linking Connector.</p>	<p>• Replace Heater.</p> <p>• Replace TH2 (Safety Thermostat) and TH3 (Hi-Limit thermostat)</p> <p>• Replace TH2 (Safety Thermostat) and TH3 (Hi-Limit thermostat)</p> <p>• Check Motor and replace it.</p>

## ■ Test 7 GAS Valve test - Gas Type

Caution	When measuring power, be sure to wear insulated gloves, to avoid electric shock.
Trouble Symptom	While operating, Heating will not work. Drying time takes longer.
Measurement Condition	With dryer power on

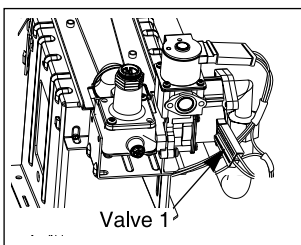

Power On & Start (Normal Cycle)

NO

When measuring Valve 1 voltage,  
More than DC 90V?

NO

• Check thermostat  
Hi limit Safety

YES

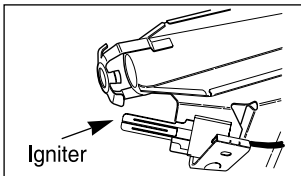

Igniter operates?  
(after 1 min, Igniter becomes reddish)

NO

• Check Igniter &  
Frame detect

YES

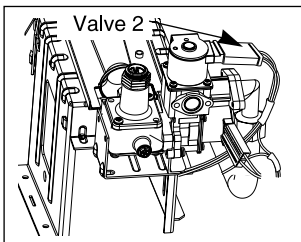

When measuring Valve 2 voltage, Value is more  
than DC 90V? (10 sec after Igniter off)

YES

• Check Gas  
connection or  
Gas supply

NO

When measuring terminal resistance on Valve 1 and  
Valve 2, Valves are more than 1.5 ~ 2.5kΩ?  
(Measure after Off)

YES

• Change Valve

NO

If "Valve 1" and "Valve 2" are under DC 10V, Valves  
are Off?

NO

• Change Valve

YES

• Harness check  
• Controller change

**NOTE:** When the gas valve operates after disassembling, ignition will be off several seconds.  
It is normal because there is no circulation of air.

## ■ Test 8 Semi Conductor

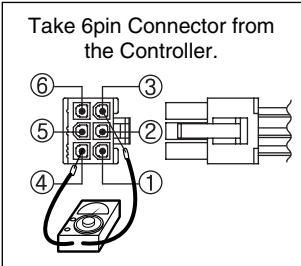
<b>Caution</b>	Before measuring resistance, be sure to turn Power off, and do voltage discharge. (When discharging, contact the metal plug of Power cord with earth line.)
<b>Trouble Symptom</b>	Degree of Resistance is not in $300 \pm 30 \Omega$
<b>Measurement Condition</b>	Turn the Dryer's Power Off, then measure resistance.
<div style="display: flex; align-items: center;"> <div style="border: 1px solid black; padding: 5px; margin-right: 20px;"> <p>Take 6pin Connector from the Controller.</p>  </div> <div style="border: 1px solid black; padding: 10px; width: 60%;"> <p>When measuring resistance ③-④, ④-⑤ Is resistance <math>300 \pm 20 \Omega</math>?</p> <p style="text-align: center;"><b>NO</b> →</p> <p style="text-align: center;"><b>YES</b> ↓</p> </div> <div style="border: 1px solid black; padding: 10px; margin-left: 20px;"> <ul style="list-style-type: none"> <li>• Check Semi-conductor and Harness Connector</li> <li>• Check Harness linking connector</li> </ul> </div> </div>	

## ■ Test 9 Motor Assembly, DC, Pump

<b>Caution</b>	Before measuring resistance, be sure to turn Power off, and do voltage discharge. (When discharging, contact the metal plug of Power cord with earth line.)
<b>Trouble Symptom</b>	During Diagnostic Test, E5 Error occur.
<b>Measurement Condition</b>	Turn the Dryer's Power Off, then measure resistance.
<div style="display: flex; align-items: center; justify-content: center;"> <div style="border: 1px solid black; padding: 10px; margin-right: 20px;"> <p>After activating the *diagnostic test, press START/PAUSE button 4 times. Is AD value displayed higher than 10 ?</p> <p style="text-align: center;"><b>NO</b> →</p> <p style="text-align: center;"><b>YES</b> ↓</p> </div> <div style="border: 1px solid black; padding: 10px; margin-left: 20px;"> <ul style="list-style-type: none"> <li>• Replace the DC Pump</li> </ul> </div> </div> <div style="border: 1px solid black; padding: 10px; margin: 10px auto; width: 30%; text-align: center;"> <p>Normal condition</p> </div> <p>* diagnostic test : go to page 22</p>	

**Warning**

Changing orifices and gas valve adjustments improperly can result in an explosion and/or fire. Conversion must be made by a qualified technician.

**Initially**, Natural Gas mode is set. Propane Gas Orifice is on sale as a Service Part to authorized servicers only.

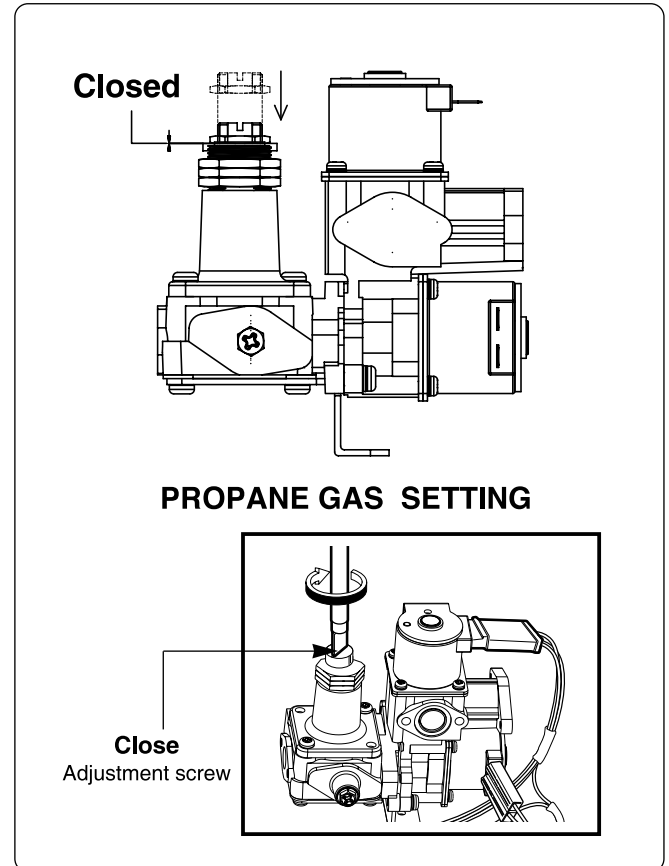
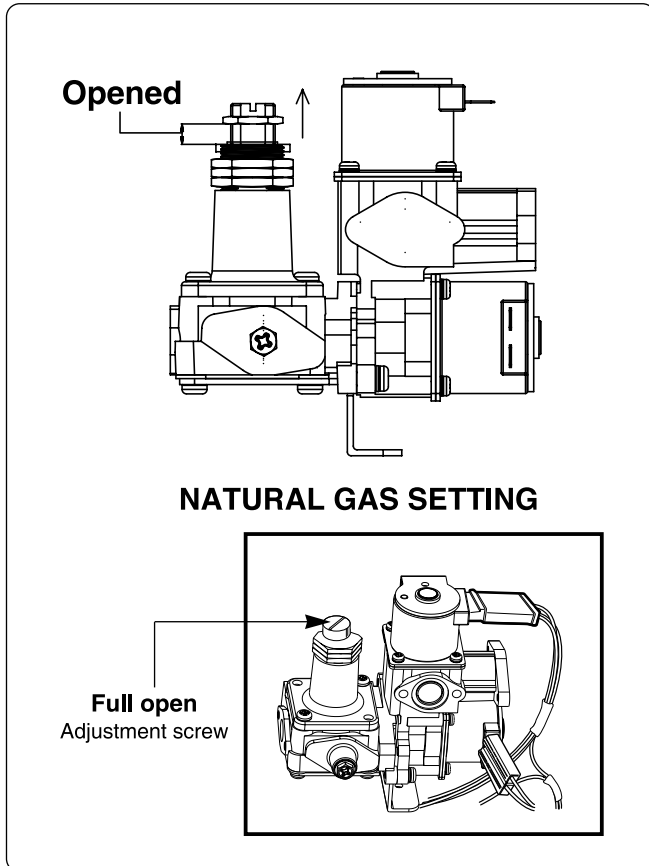
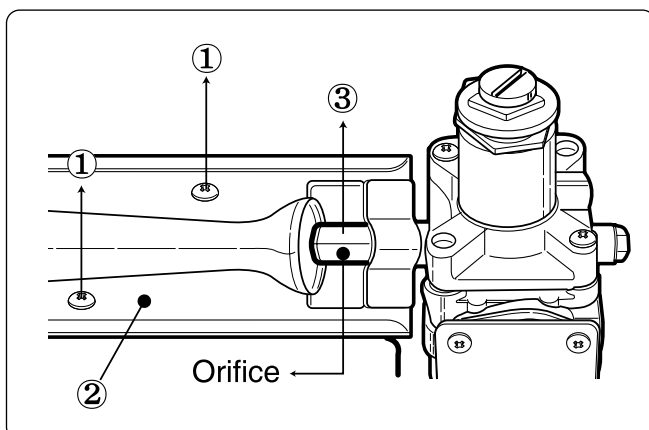
**STEP 1 : VALVE SETTING****STEP 2 : ORIFICE CHANGE**

- ① Remove 2 screws.
- ② Disassemble the pipe assembly.
- ③ Replace Natural Gas orifice with Propane Gas orifice.

Gas type	Orifice P/No	Marking	Shape
<b>Natural Gas</b>	4948EL4001B	NCU	
<b>Propane Gas</b>	4948EL4002B	PCU	

※ **Kit contents:** Orifice (Dia. = 1.613mm, for Propane Gas)  
Replace Label  
Instruction Sheet

## ■ GAS VALVE FLOW

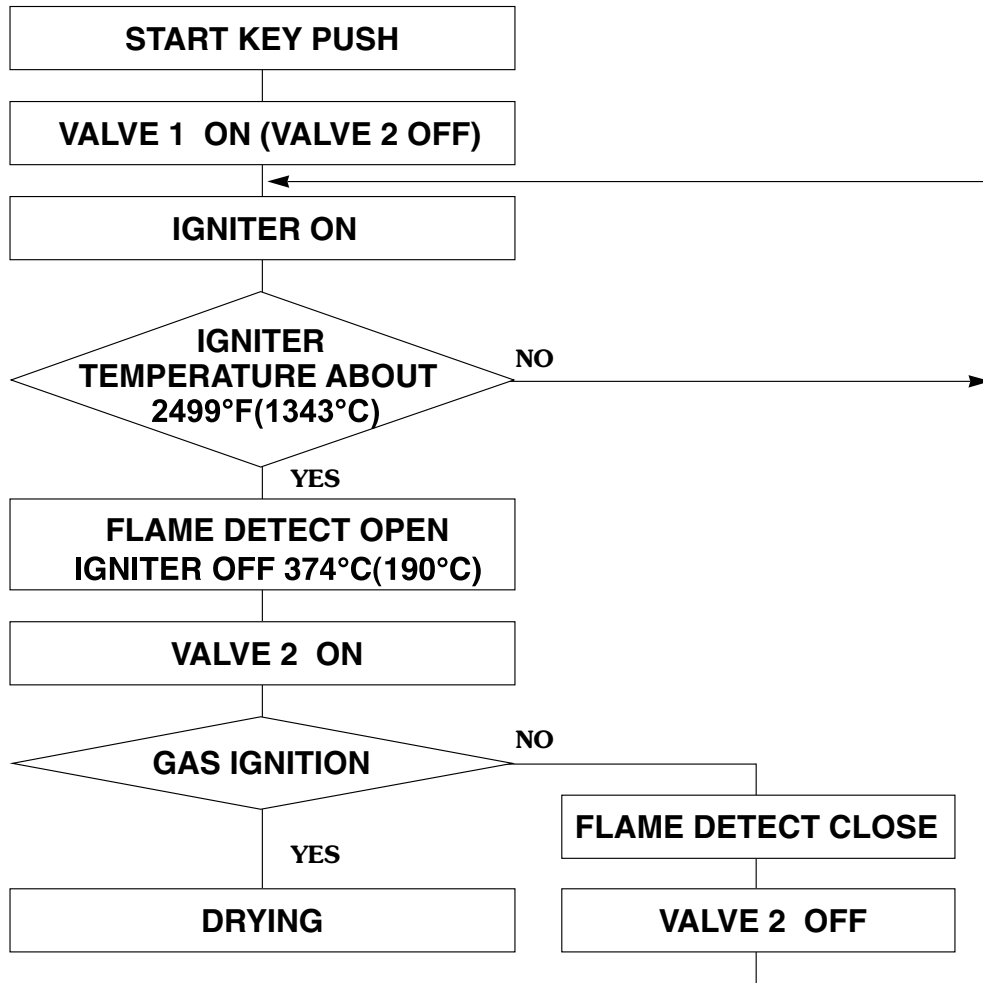

### GAS IGNITION

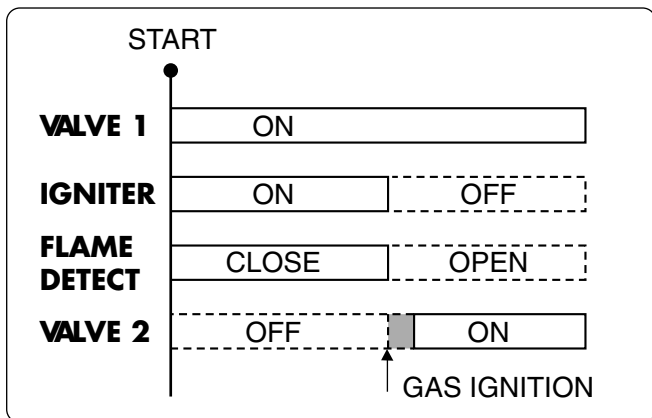

### GAS VALVE STRUCTURE

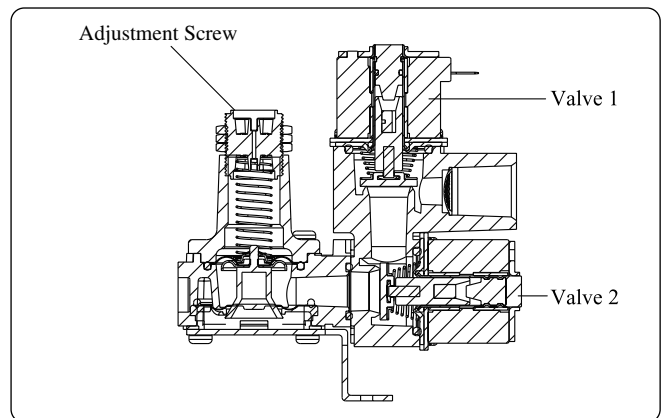

※ Disassemble and repair the unit only after pulling out power plug from the outlet.

### CONTROL PANEL ASSEMBLY

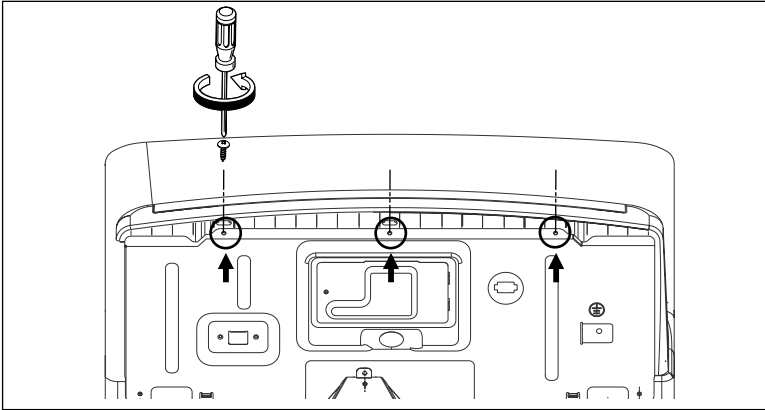

**1.** Remove the 3 screws from the back panel.

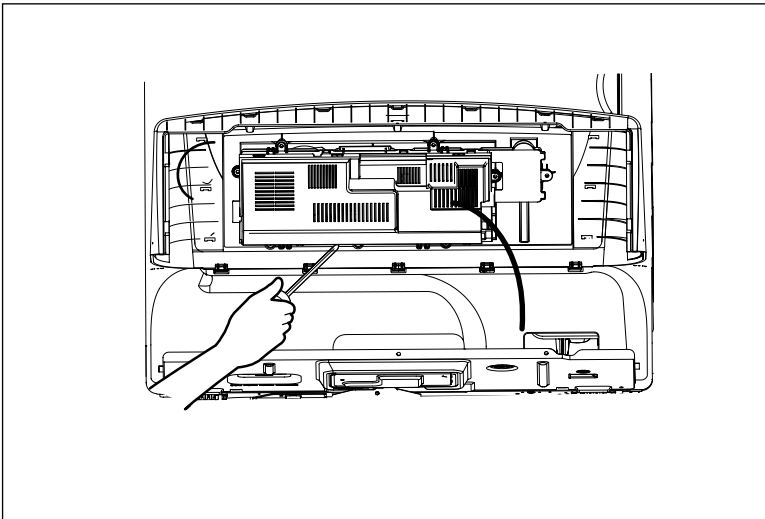

**2.** Place a towel over the top cover to prevent scratch to the surface. Gently lift each corner of the back panel, then roll it forward so it rests on top of the dryer.

**3.** With a flat blade screwdriver, press the tabs on the side of the PWB(PCB) box and gently pry it open.

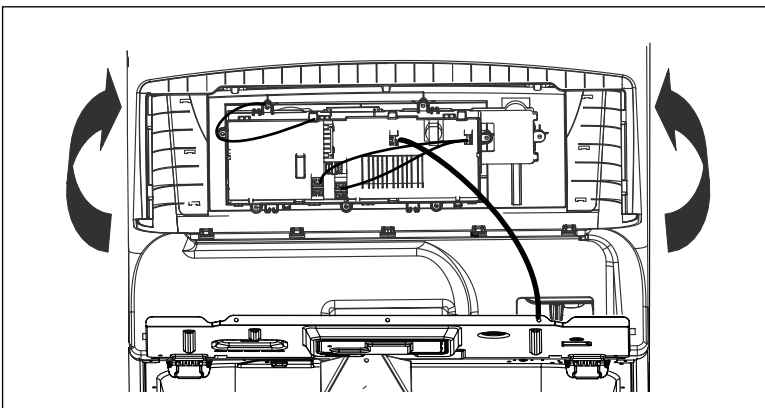

**4.** Disconnect the wiring from the PWB(PCB) board.

**5.** Disassemble the control panel assembly from top cover.

## Control Panel

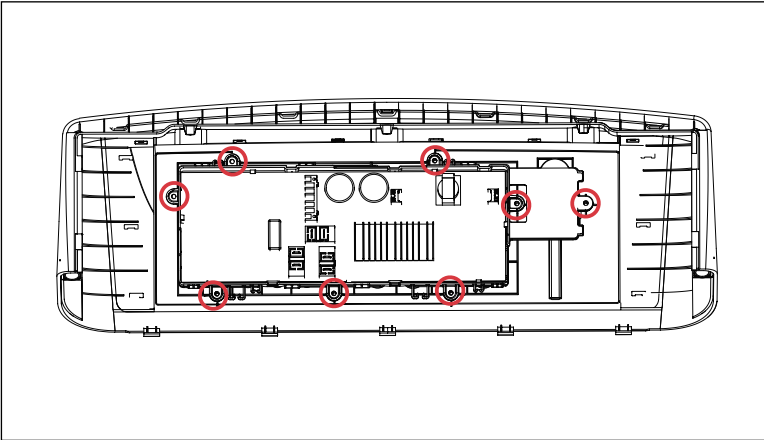

**1.** Remove 8 screws from control panel assembly.

**2.** Separate PCB from control panel.

## Panel Rear (Elec.)

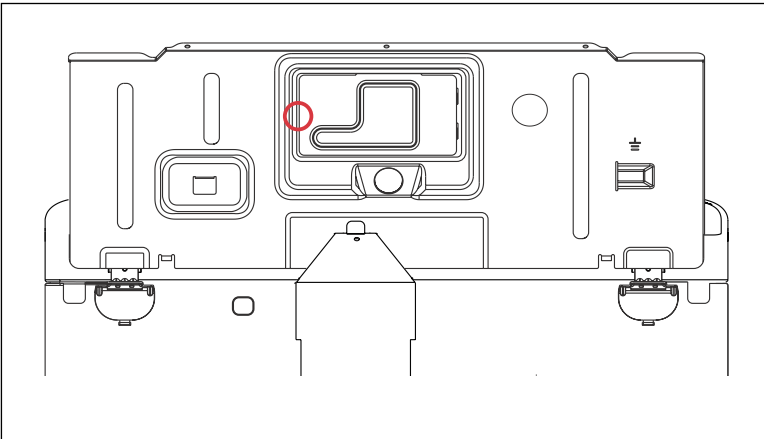

**1.** Remove 1 screw.

**2.** Pull out the cover.

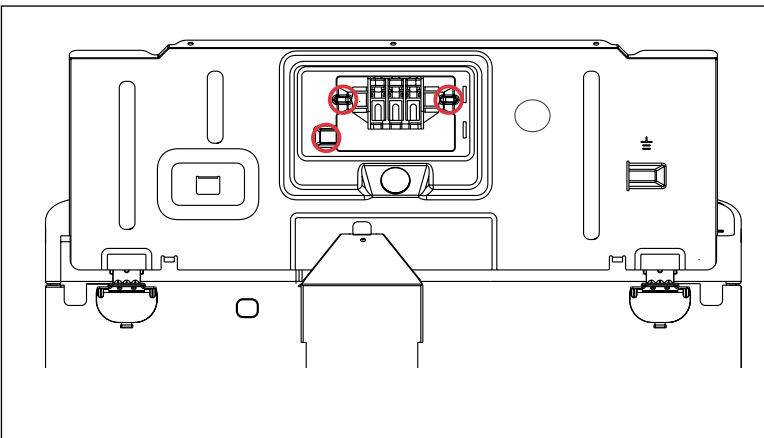

**1.** Unravel 3 screws.

**2.** Disassemble terminal block and wire from panel rear.

## Panel Rear (common)

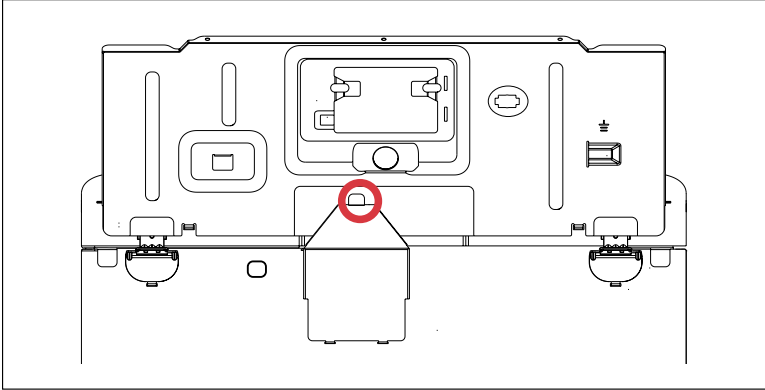

1. Unravel a one screw for removing safety cover.
2. Remove 2 screws remained on the panel rear.
3. Lift out the panel rear.

## TOP COVER

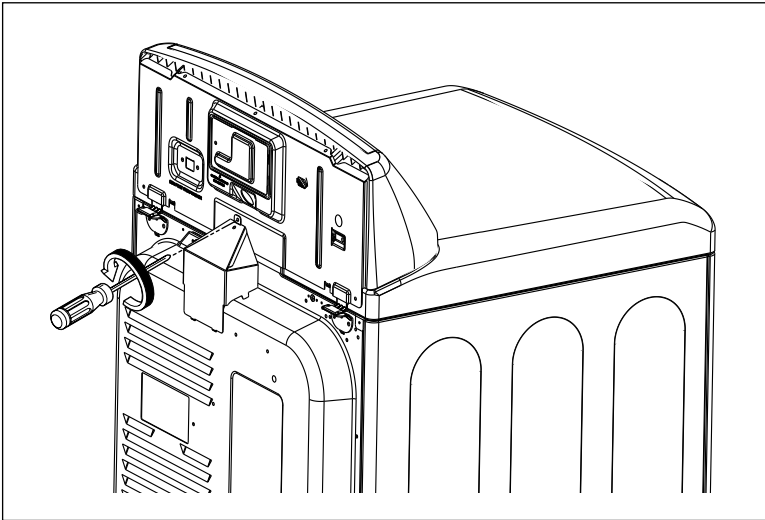

1. Before lift up the top cover, remove the safety cover necessarily.
2. If you don't remove the safety cover, safety cover will be destructible.

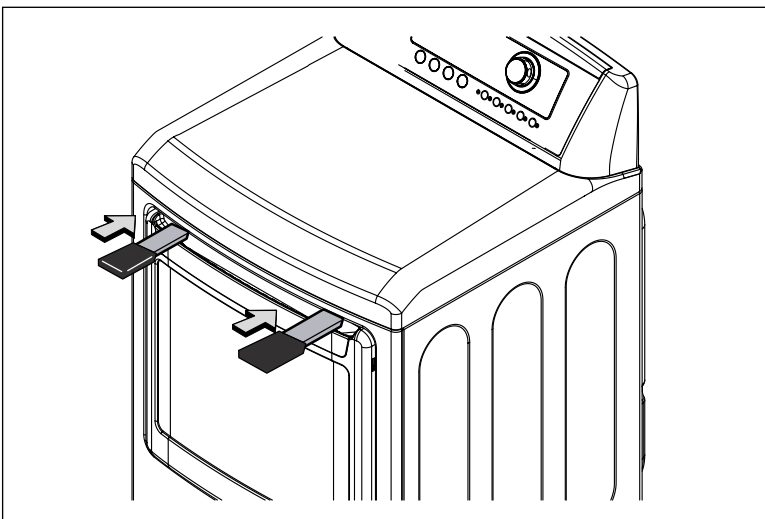

3. After check the safety cover, press the holder with flat-tip screw driver inside the top cover.
4. Open the top cover.
5. Disassembly top cover from cabinet assembly.

## CABINET COVER

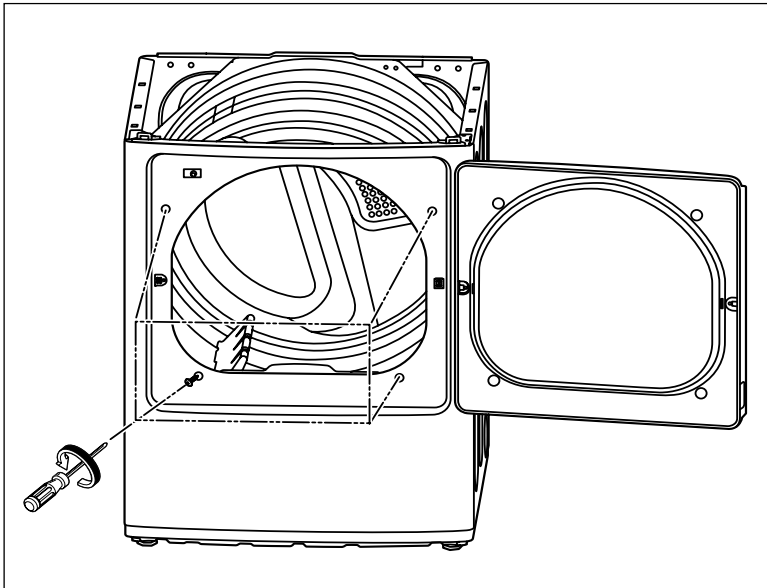

1. Open the door and remove the 4 screws from the cabinet cover then close the door.

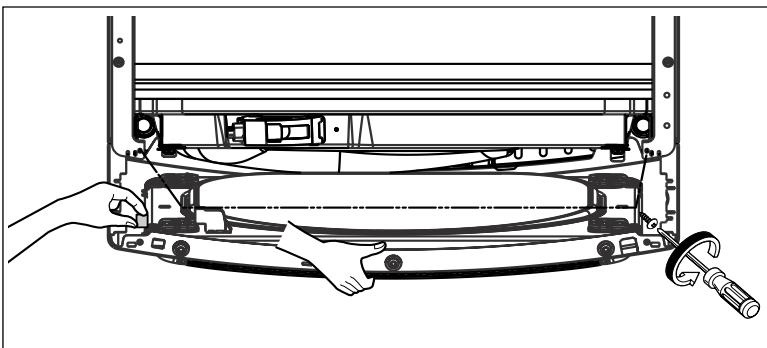

2. Remove the 2 screws then slide the cabinet cover toward the front of dryer.
3. Remove the 2 screws then tilt the cabinet cover toward the front of dryer slightly.
4. Disconnect wiring to the door switch and lift the cabinet cover.

## TUB DRUM [FRONT]

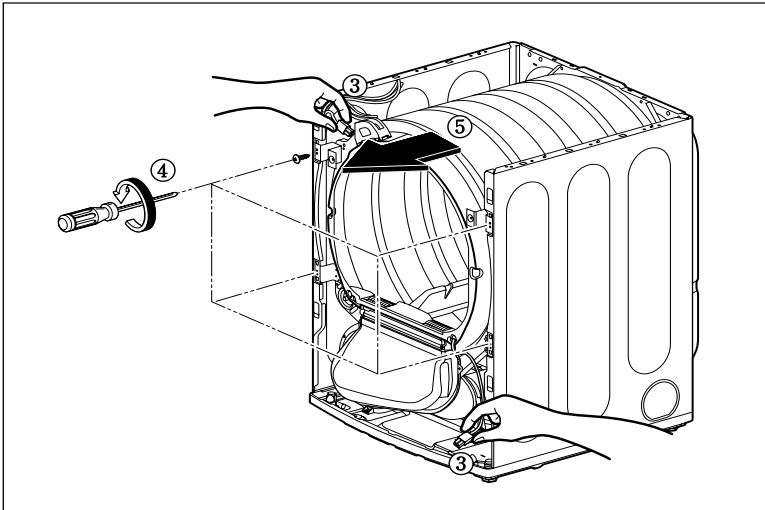

1. Disassemble the top plate.
2. Remove Cover Cabinet.
3. Disconnect the door lamp and electrode sensor connector.
4. Remove 4 screws.
5. Disassemble the Tub Drum [Front ].

## DRUM ASSEMBLY

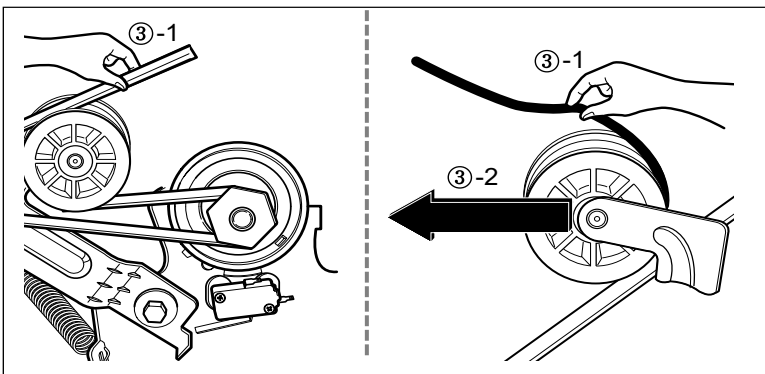

1. Disassemble the top plate.
2. Remove the Cabinet Cover and Tub drum [front ].
3. Loosen belt from motor and idler pulleys.
4. Carefully remove the drum.

## CHANGING THE DRUM LAMP

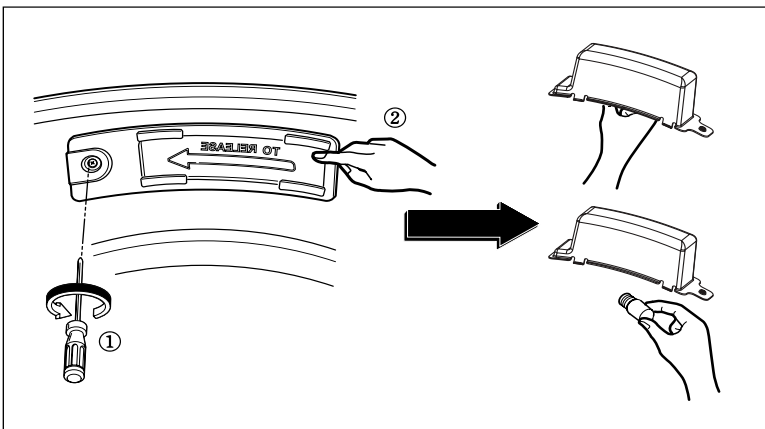

1. Disassemble the door.
2. Hold the lamp shield in place while removing the screw.
3. Slide the shield up and remove.
4. Remove the bulb and replace with a 15 watt, 120 volt candelabra-base bulb.
5. Replace the lamp shield and screw.

## DRYER EXHAUST CHANGE

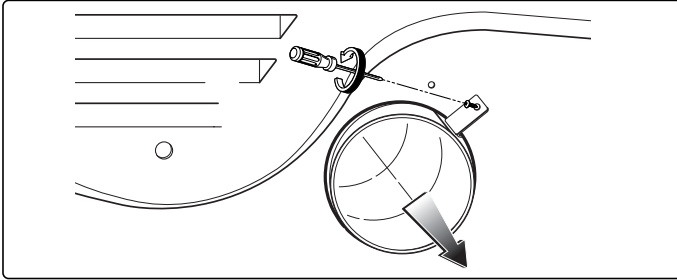

**1.** Remove a screw and the exhaust duct.

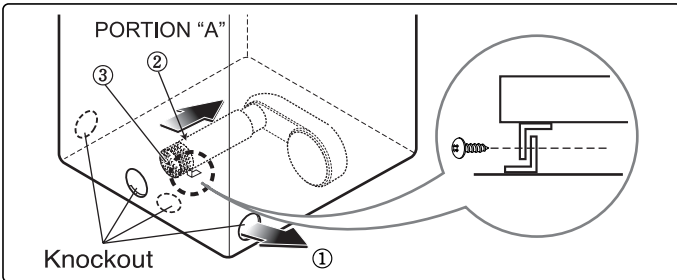

**2-1.** Detach and remove a knockout at the bottom, left or right side as desired. (Right Side Vent not available on Gas dryer)  
①, ②, ③ the order of work.

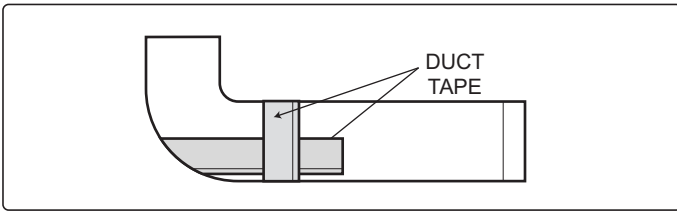

**2-2.** Reconnect the another duct [11 in (28cm)] to the blower housing, and attach the duct to the base. (Duct is a SVC part)

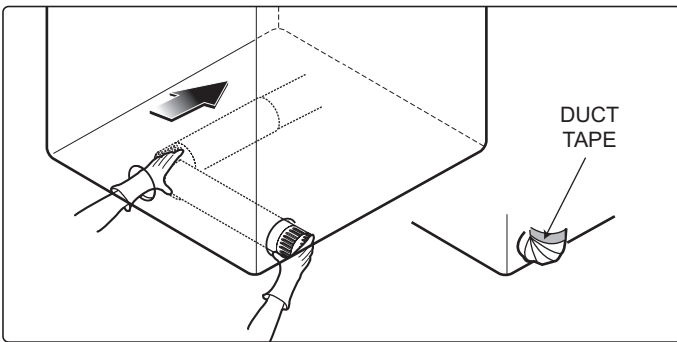

**3-1.** Pre-assemble 4" elbow with 4" duct.  
Wrap duct tape around joint.

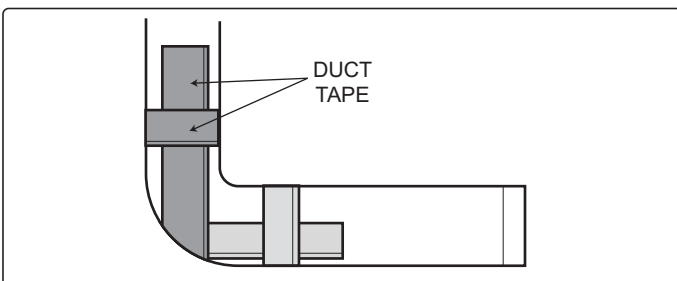

**3-2.** Insert the elbow duct assembly through the side opening and connect the elbow to the internal duct.

## FILTER ASSEMBLY

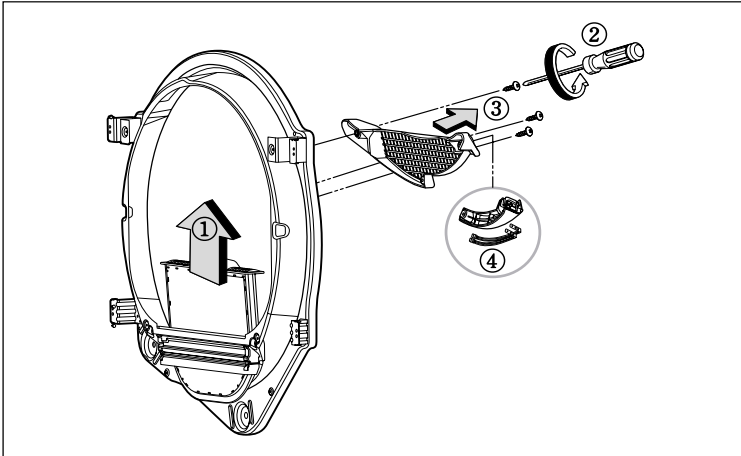

- 1.** Remove the filter.
- 2.** Remove 3 screws.
- 3.** Remove the Cover Grid.
- 4.** Disconnect the electrode sensor.

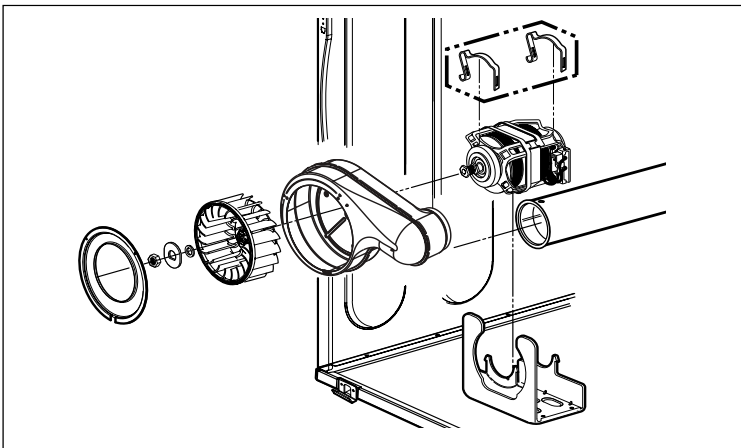

- 1.** Disassemble the top plate.
- 2.** Remove the Cabinet Cover and Tub Drum [Front ].
- 3.** Remove the Drum assembly.
- 4.** Remove 2 screws and cover (Air guide).
- 5.** Remove the bolt and washer.
- 6.** Remove the fan.
- 7.** Disconnect the motor clamp and motor.

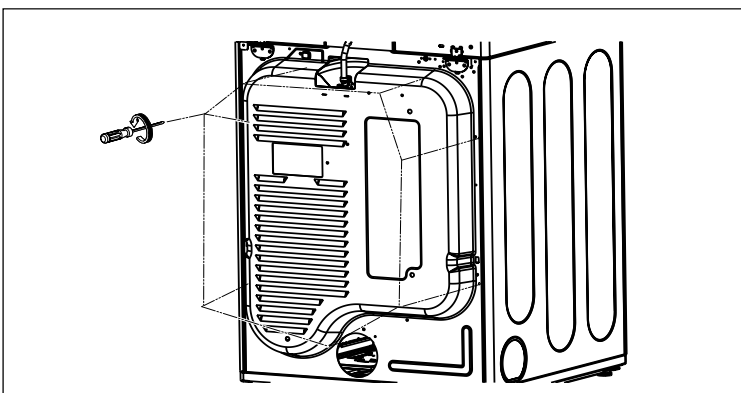

- 1.** Disassemble the top plate.
- 2.** Remove the Cabinet Cover and Tub Drum [Front ].
- 3.** Remove the Drum assembly.
- 4.** Remove 7 screws.
- 5.** Remove the Back Cover.

## AIR DUCT

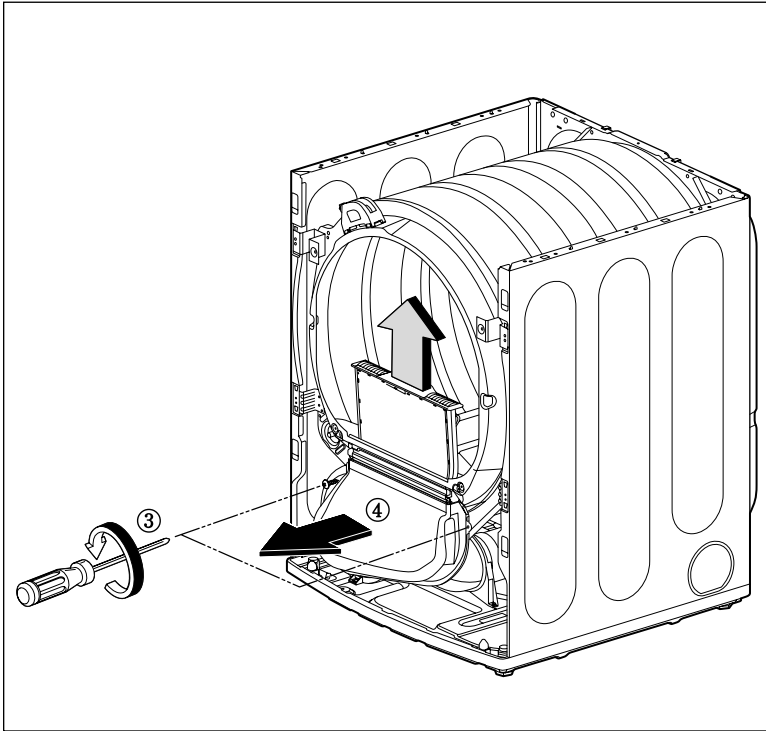

1. Disassemble the top plate.
2. Remove the Cover Cabinet.
3. Remove the filter and 2 screws.
4. Remove the air duct.

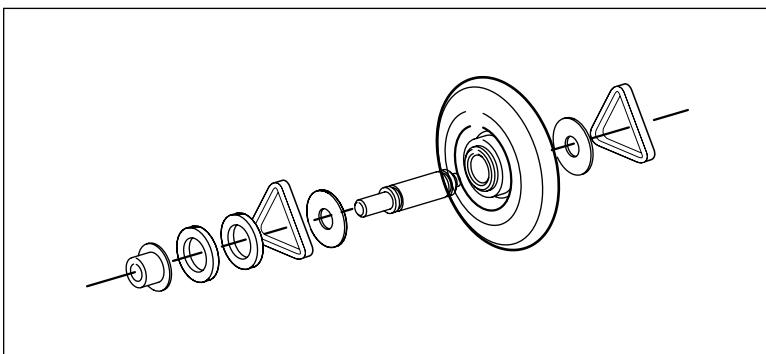

1. Disassemble the top plate.
2. Remove the Cover Cabinet and Tub Drum [Front ].
3. Remove the Drum assembly and Tub Drum [Rear].
4. Disconnect the Air duct from the Tub Drum [Front ].
5. Remove the roller from the Tub Drum [Front ] and Tub Drum [Rear ].

# 11

## EXPLODED VIEW

### 11-1. Control Panel & Plate Assembly

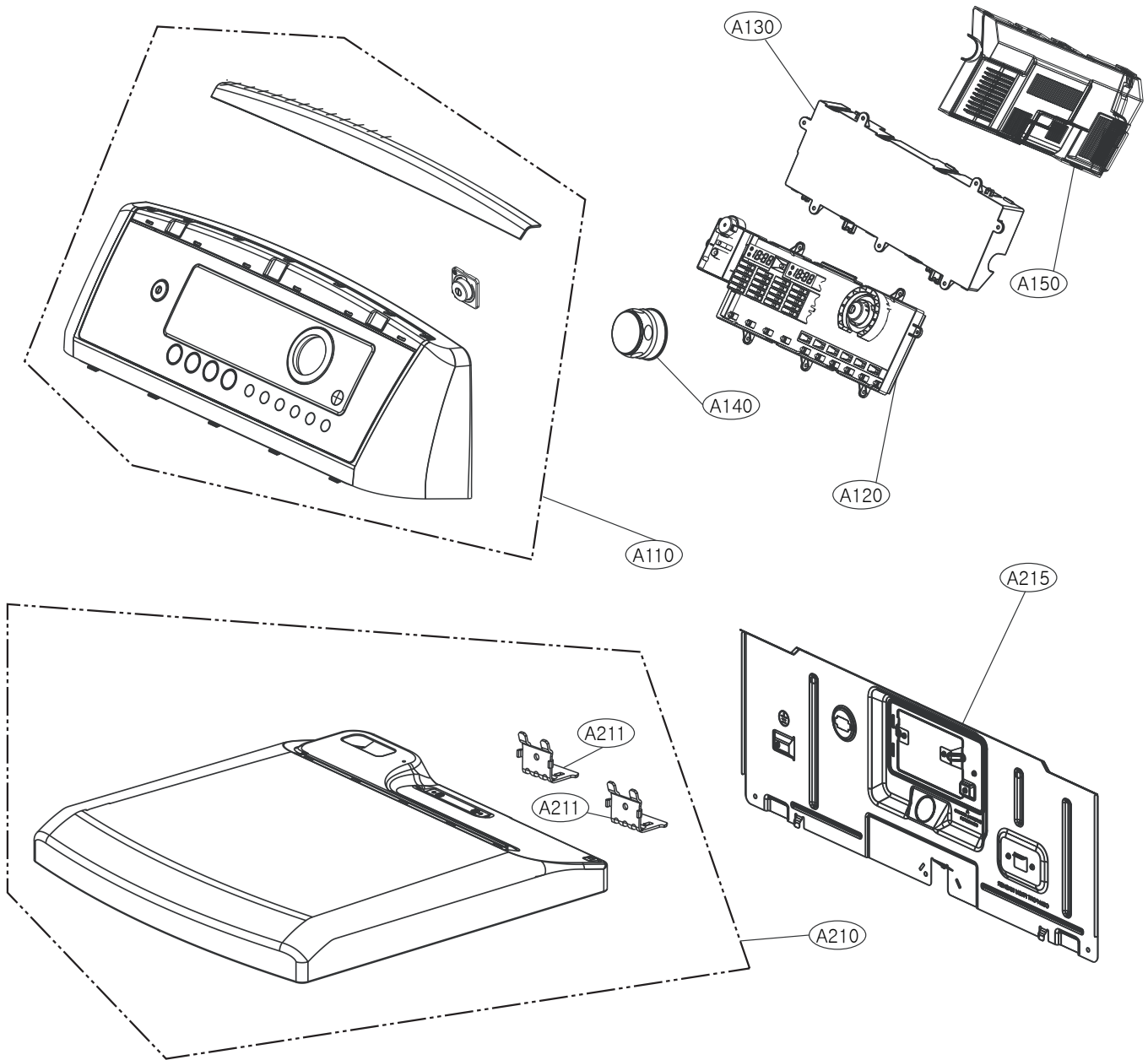

# 11-2-2. Cabinet & Door Assembly: Gas Type

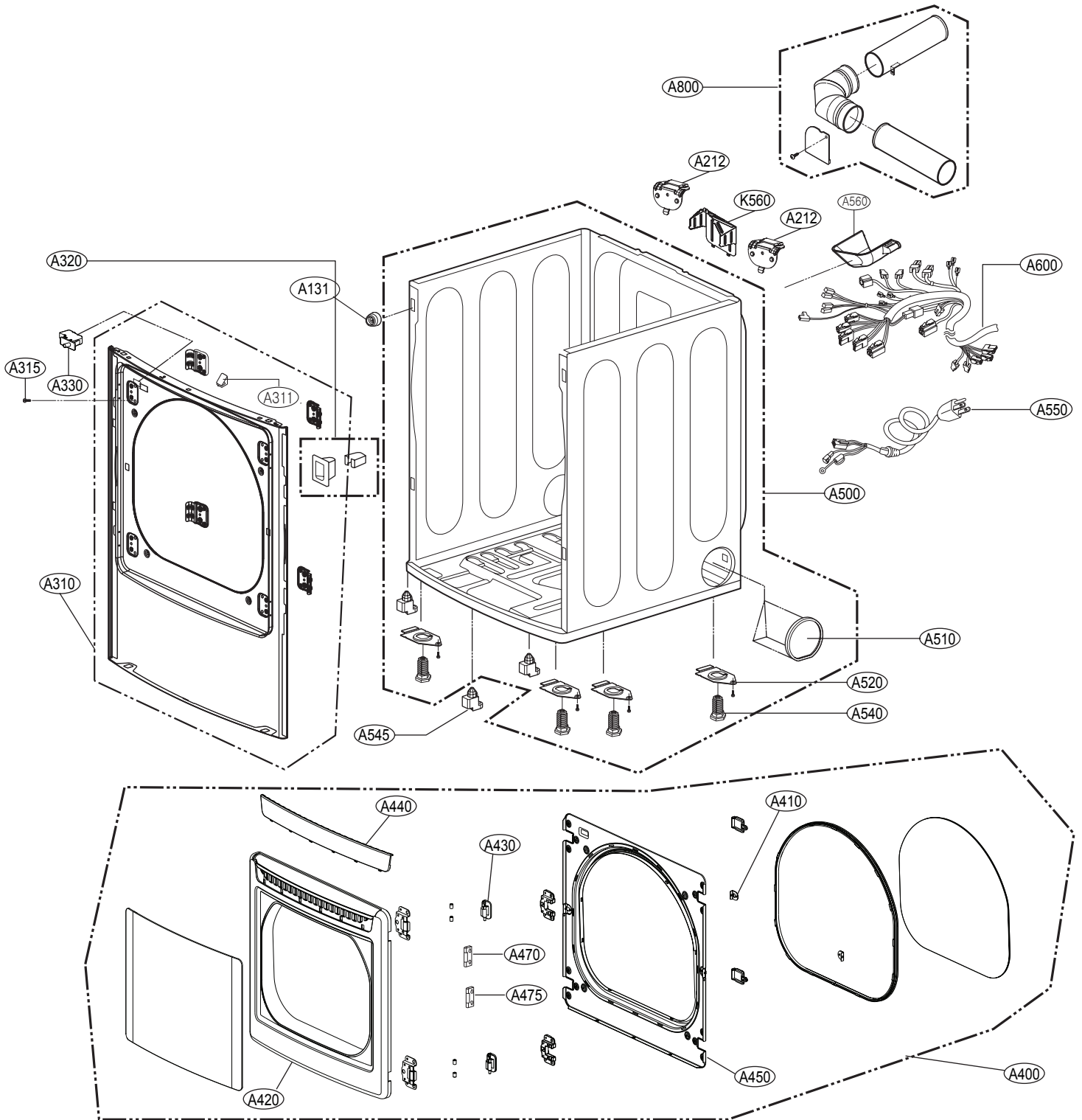

# 11-3-2. Drum & Motor Assembly: Gas type

