

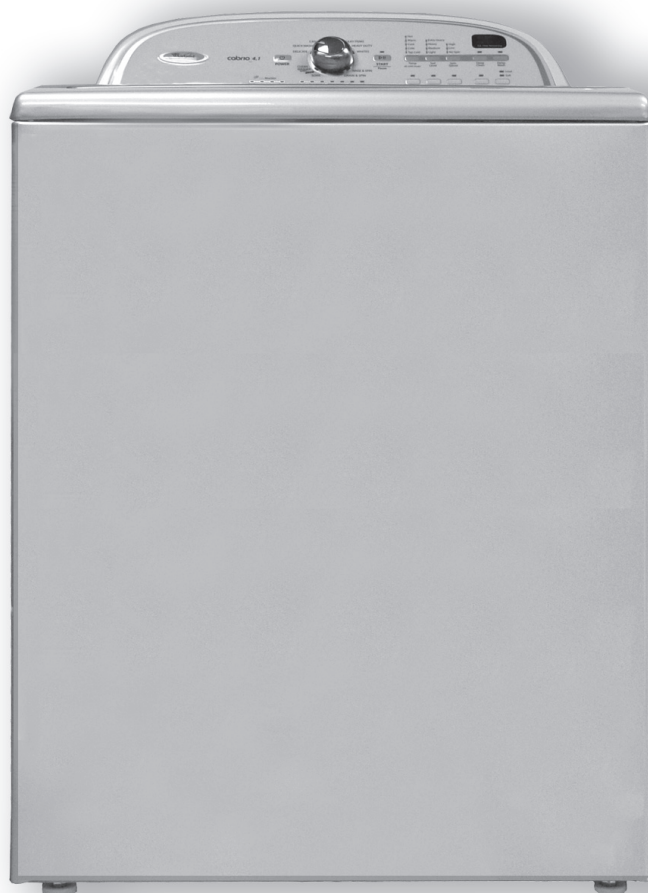

TECHNICAL EDUCATION

Vertical Modular Washer



MVWC400XW	WTW4950XW
MVWX500XW	WTW5500XW
MVWX550XW	WTW5550XW
MVWX600XW	WTW5600XW
MVWX700XW	WTW5700XW

JOB AID W10329932

FORWARD

This Whirlpool Job Aid, "Vertical Modular Washer" (Part No. W10329932), provides the In-Home Service Professional with information on the installation, operation, and service of the "Vertical Modular Washer". For specific information on the model being serviced, refer to the "Use and Care Guide," or "Tech Sheet" provided with the washer.

The Wiring Diagram used in this Job Aid is typical and should be used for training purposes only. Always use the Wiring Diagram supplied with the product when servicing the washer.

GOALS AND OBJECTIVES

The goal of this Job Aid is to provide information that will enable the In-Home Service Professional to properly diagnose malfunctions and repair the "Vertical Modular Washer"

The objectives of this Job Aid are to:

- Understand and follow proper safety precautions.
- Successfully troubleshoot and diagnose malfunctions.
- Successfully perform necessary repairs.
- Successfully return the washer to its proper operational status.

WHIRLPOOL CORPORATION assumes no responsibility for any repairs made on our products by anyone other than authorized In-Home Service Professionals.

TABLE OF CONTENTS

	Page
GENERAL	1-1
GENERAL	1-1
Washer Safety	1-1
Model & Serial Number Designations	1-2
Model & Serial Number Label And Tech Sheet Locations	1-4
Specifications	1-5
Specifications (Maytag Models)	1-6
INSTALLATION INFORMATION	2-1
Washer Safety	2-1
Installation Requirements	2-2
Electrical Requirements	2-4
Installation Instructions	2-4
PRODUCT OPERATION	3-1
Theory Of Operation	3-1
Introduction	3-1
Drive System	3-1
Actuator	3-3
Lid Lock Mechanism	3-4
Control Panel And Features	3-5
Cycle Guide	3-8
Using The Washer	3-9
Using Laundry Product Dispensers	3-10
Troubleshooting	3-14
COMPONENT ACCESS	4-1
Component Locations	4-1 - 4-2
Removing The Control Panel	4-3
Removing The Control	4-4
User Interface Removal And Installation Procedure	4-5
Removing The Top	4-6
Removing The Water Inlet Valve	4-7
Removing The Detergent Dispenser Assembly	4-8
Removing The Lid Switch/Lock Assembly	4-9
Removing The Lid Strike On Glass Lid Models	4-10
Removing The Shifter	4-11
Removing The Drain Pump	4-12
Removing The Drive Belt And Motor	4-13
Removing The Splutch	4-14
Removing The Gearcase	4-15
Removing The Tub Ring	4-17
Removing The Impeller And Basket	4-18
Basket Drive Block Removal And Installation Procedure	4-19
Removing the Tub	4-21

TABLE OF CONTENTS (continued)

TESTING	5-1
Activating The Serv Ice Diagnostic Modes	5-2
Diagnostic Guide	5-3
Fault Code Display Mode	5-3
Automatic Test Mode	5-4
Manual Test Mode	5-4
Calibration Mode	5-4
Sales Demo Mode	5-4
UI Test Mode	5-5
Software Version Display Mode	5-5
Customer Viewable Fault Codes	5-5
Automatic Test Mode	5-8
Manual Test Mode	5-9
DIAGNOSTICS	6-1
Diagnostic Guide	6-1
Troubleshooting Tests	6-4
WIRING DIAGRAMS	7-1
Washer	7-1

GENERAL WASHER SAFETY

Your safety and the safety of others are very important.

We have provided many important safety messages in this manual and on your appliance. Always read and obey all safety messages.



This is the safety alert symbol.

This symbol alerts you to potential hazards that can kill or hurt you and others.

All safety messages will follow the safety alert symbol and either the word “DANGER” or “WARNING.” These words mean:

! DANGER

You can be killed or seriously injured if you don't immediately follow instructions.

! WARNING

You can be killed or seriously injured if you don't follow instructions.

All safety messages will tell you what the potential hazard is, tell you how to reduce the chance of injury, and tell you what can happen if the instructions are not followed.

IMPORTANT: Electrostatic Discharge (ESD) Sensitive Electronics

ESD problems are present everywhere. Most people begin to feel an ESD discharge at approximately 3000V. It takes as little as 10V to destroy, damage, or weaken the main control assembly. The new main control assembly may appear to work well after repair is finished, but a malfunction may occur at a later date due to ESD stress.

- Use an anti-static wrist strap. Connect wrist strap to green ground connection point or unpainted metal in the appliance

-OR-

Touch your finger repeatedly to a green ground connection point or unpainted metal in the appliance.

- Before removing the part from its package, touch the anti-static bag to a green ground connection point or unpainted metal in the appliance.
- Avoid touching electronic parts or terminal contacts; handle electronic control assembly by edges only.
- When repackaging main control assembly in anti-static bag, observe above instructions.

MODEL & SERIAL NUMBER DESIGNATIONS

MODEL NUMBER	W	T	W	4	2	00	X	Q	0
BRAND A=Admiral C=Crosley E=Estate I=Inglis M=Maytag N=Amana R=Roper W=Whirlpool									
ACCESS E=Electric F=Front Load G=Gas H=Horizontal T=Top Load V=Vertical W=Workspace									
PRODUCT B=Combo C=Compact D=Dryer P=Pedestal T=Thin Twin/Stack W = Washer									
SERIES 1=Innovation 2=Commercial 3=Compact 4=VMW Good & Stack 5=LEAP & VMW Better 6=Oasis 7=24" Front Load & VMW Best 8=Mid Line Front Load 9=Duet Front Load									
PRICE POINT LEVELS (1-9)									
TRADE PARTNER ID (00 = BRANDED)									
YEAR OF INTRODUCTION X = 2010									
COLOR CODE A=Aspen B=Black C=Tuscan Chestnut E=Ocean Sapphire F=Classic Red K=Blue L=Silver/Pewter Q=Mono White T=Bisque U=Ult Silver W=White w/Gray Z=White w/Sapphire									
ENGINEERING CHANGE (0, 1, 2, ETC.)									

SERIAL NUMBER	C	0	41	01002
DIVISION RESPONSIBILITY C = CLYDE, OH				
YEAR OF PRODUCTION 2010 = 0 2011 = 1				
WEEK OF PRODUCTION 41 = 41ST WEEK				
PRODUCT SEQUENCE NUMBER				

MODEL & SERIAL NUMBER DESIGNATIONS (MAYTAG)

MODEL NUMBER	M	E	W	X	7	00	X	Q	0
BRAND A=Admiral C=Crosley E=Estate I=Inglic M=Maytag N=Amana R=Roper W=Whirlpool									
ACCESS E=Electric F=Front Load G=Gas H=Horizontal T=Top Load V=Vertical W=Workspace									
PRODUCT B=Combo C=Compact D=Dryer P=Pedestal T=Thin Twin/Stack W = Washer									
SERIES A=All / Accessory B=Bravos C=Centennial E=Epic S=Stack X=VMW Better Z=Epic Z									
PRICE POINT LEVELS (1-9)									
TRADE PARTNER ID (00 = BRANDED)									
YEAR OF INTRODUCTION X = 2010									
COLOR CODE A=Aspen B=Black C=Tuscan Chestnut E=Ocean Sapphire F=Classic Red K=Blue L=Silver/Pewter Q=Mono White T=Bisque U=Ult Silver W=White w/Gray Z=White w/Sapphire									
ENGINEERING CHANGE (0, 1, 2, ETC.)									

SERIAL NUMBER	C	0	41	01002
DIVISION RESPONSIBILITY C = CLYDE, OH				
YEAR OF PRODUCTION 2010 = 0 2011 = 1				
WEEK OF PRODUCTION 41 = 41ST WEEK				
PRODUCT SEQUENCE NUMBER				

MODEL & SERIAL NUMBER LABEL AND TECH SHEET LOCATIONS

The Model & Serial Number Label and Tech Sheet locations are shown below.

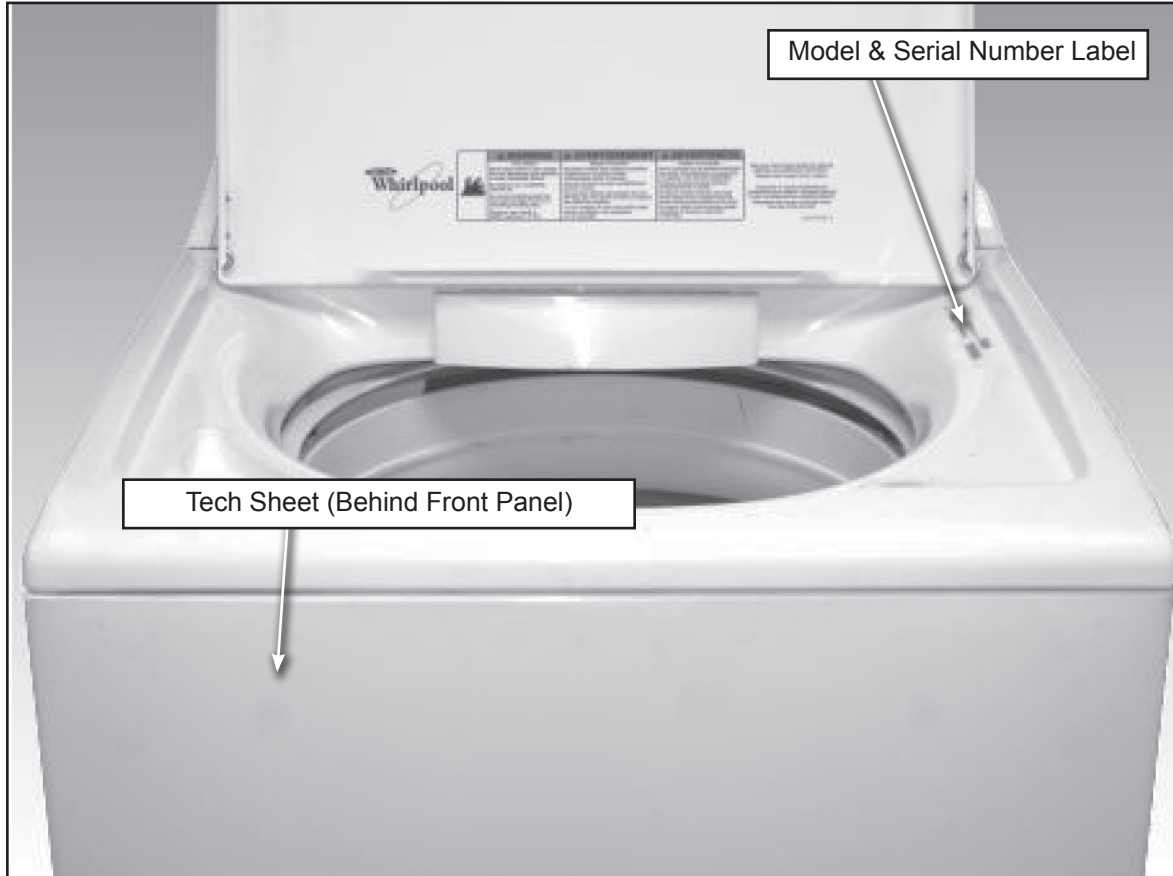

SPECIFICATIONS

Model Number	WTW49550XW	WTW5500XW	WTW5550XW
Model Description	Top-Load Washer	Top-Load Washer	Top-Load Washer
Color	White	White	White
Capacity (Cu. Ft. DOE)	3.7	3.7	3.7
IEC Capacity	4.3	4.3	4.3
Energy Star / Tier Level (2011)	2.4 MEF, 4.0 WF	2.4 MEF, 4.0 WF	2.4 MEF, 4.0 WF
Basket Material	Stainless Steel	Stainless Steel	Stainless Steel
Bleach Disp.	Dump Bleach	Dump Bleach	Dump Bleach
Fab. Sof. Disp.	Downeyball	Timed Flush-Drawer	Timed Flush-Drawer
Detergent Disp.	No	Drawer	Drawer
Lid	Solid	Solid	Solid
Water Temps	4	4	4
Max Spin Speeds	800	800	800
Agitator or Impeller	Impeller-Unique	Impeller-Unique	Impeller-Unique
Height	43"	43"	43"
Install Depth: Min - Max	27"	27"	27"
Width	26"	26"	26"

SPECIFICATIONS

Model Number	WTW5600XW	WTW5700XW
Model Description	Top-Load Washer	Top-Load Washer
Color	White	White
Capacity (Cu. Ft. DOE)	3.7	3.7
IEC Capacity	4.3	4.3
Energy Star / Tier Level (2011)	2.4 MEF, 4.0 WF	2.4 MEF, 4.0 WF
Basket Material	Stainless Steel	Stainless Steel
Bleach Disp.	Dump Bleach	Dump Bleach
Fab. Sof. Disp.	Timed Flush-Drawer	Timed Flush-Drawer
Detergent Disp.	Drawer	Drawer
Lid	Solid	Window
Water Temps	4	5
Max Spin Speeds	800	800
Agitator or Impeller	Impeller-Unique	Impeller-Unique
Height	43"	43"
Install Depth: Min - Max	27"	27"
Width	26"	26"

SPECIFICATIONS (Maytag Models)

Model Number	MVWC400XW	MVWC500XW	MVWC550XW
Model Description	Top-Load Washer	Top-Load Washer	Top-Load Washer
Color	White	White	White
Capacity (Cu. Ft. DOE)	3.7	3.7	3.7
IEC Capacity	4.3	4.3	4.3
Energy Star / Tier Level (2011)	2.4 MEF, 4.0 WF	2.4 MEF, 4.0 WF	2.4 MEF, 4.0 WF
Basket Material	Stainless Steel	Stainless Steel	Stainless Steel
Bleach Disp.	Dump Bleach	Dump Bleach	Dump Bleach
Fab. Sof. Disp.	Downeyball	Drawer	Drawer
Detergent Disp.	No	Drawer	Drawer
Lid	Solid	Solid	Solid
Water Temps	4	4	4
Max Spin Speeds	800	800	800
Agitator or Impeller	Impeller-Unique	Impeller-Unique	Impeller-Unique
Height	43"	43"	43"
Install Depth: Min - Max	27"	27"	27"
Width	26"	26"	26"

SPECIFICATIONS (Maytag Models con't)

Model Number	MVWC600XW	MVWC700XW
Model Description	Top-Load Washer	Top-Load Washer
Color	White	White
Capacity (Cu. Ft. DOE)	3.7	3.7
IEC Capacity	4.3	4.3
Energy Star / Tier Level (2011)	2.4 MEF, 4.0 WF	2.4 MEF, 4.0 WF
Basket Material	Stainless Steel	Stainless Steel
Bleach Disp.	Dump Bleach	Dump Bleach
Fab. Sof. Disp.	Drawer	Drawer
Detergent Disp.	Drawer	Drawer
Lid	Solid	Window
Water Temps	5	5
Max Spin Speeds	800	800
Agitator or Impeller	Impeller-Unique	Impeller-Unique
Height	43"	43"
Install Depth: Min - Max	27"	27"
Width	26"	26"

INSTALLATION INFORMATION

Washer Safety

Your safety and the safety of others are very important.

We have provided many important safety messages in this manual and on your appliance. Always read and obey all safety messages.



This is the safety alert symbol.

This symbol alerts you to potential hazards that can kill or hurt you and others.

All safety messages will follow the safety alert symbol and either the word “DANGER” or “WARNING.”

These words mean:

⚠ DANGER

You can be killed or seriously injured if you don't immediately follow instructions.

⚠ WARNING

You can be killed or seriously injured if you don't follow instructions.

All safety messages will tell you what the potential hazard is, tell you how to reduce the chance of injury, and tell you what can happen if the instructions are not followed.

⚠ WARNING

Excessive Weight Hazard

Use two or more people to move and install washer.

Failure to do so can result in back or other injury.

INSTALLATION REQUIREMENTS

TOOLS AND PARTS

Gather required tools and parts before starting installation.

Tools needed:

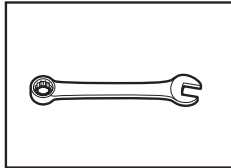

Adjustable or open end wrench $\frac{9}{16}$ " (14 mm)

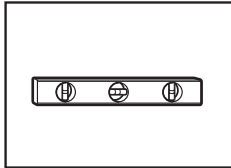

Level

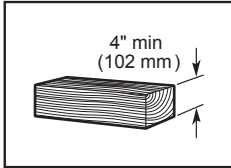

Wood block

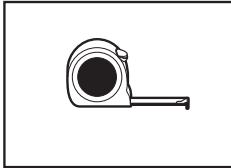

Ruler or measuring tape

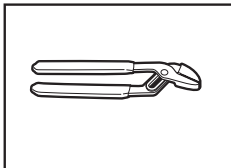

Pliers that open to $1\frac{1}{16}$ " (39.5 mm)

Optional tools:

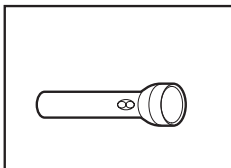

Flashlight

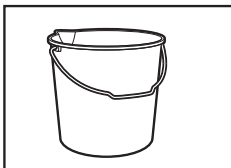

Bucket

Parts supplied:

NOTE: All parts supplied for installation are in cardboard insert in the top of the washer.

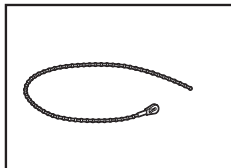

Beaded Tie Strap

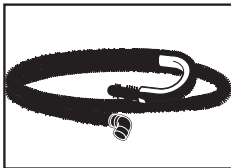

Drain hose with clamp

Parts needed: (Not supplied with washer)

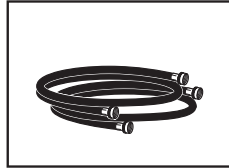

Inlet hoses with flat washers

To order, please refer to toll-free phone numbers on back page of your Use and Care Guide.

- 8212656RP 10 ft. (3.0 m) Inlet hose, Black EPDM (2 pack)
- 8212641RP 5 ft. (1.5 m) Inlet hose, Black EPDM (2 pack)
- 8212646RP 4 ft. (1.2 m) Inlet hose, Black EPDM (2 pack)
- 8212545RP 5 ft. (1.5 m) Inlet hose, Red and Blue EPDM (2 pack)
- 8212487RP 5 ft. (1.5 m) Nylon braided inlet hose (2 pack)
- 8212638RP 6 ft. (1.8 m) Nylon braided inlet hose, space saving 90° elbow, hydro-blue steel couplings (2 pack)
- 8212637RP 6 ft. (1.8 m) Inlet hose, Black EPDM, space saving 90° elbow, hydro-blue steel couplings (2 pack)

Alternate parts: (Not supplied with washer)

Your installation may require additional parts. To order, please refer to toll-free numbers on back page of your Use and Care Guide.

If you have:

You will need:

Overhead sewer

Standard 20 gal. (76 L) 39" (990 mm) tall drain tub or utility sink, sump pump and connectors (available from local plumbing suppliers)

1" (25mm) standpipe

2" (51 mm) diameter to 1" (25 mm) diameter Standpipe Adapter Kit Part Number 280130

Drain hose too short

Kit Part Number 280131

Lint clogged drain

Drain protector, Part Number 367031

LOCATION REQUIREMENTS

Select proper location for your washer to improve performance and minimize noise and possible "washer walk". Install your washer in a basement, laundry room, closet or recessed area.

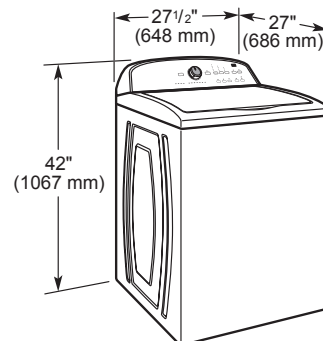

INSTALLATION REQUIREMENTS (continued)

You will need:

- A water heater set to 120° F (49° C).
- A grounded electrical outlet located within 4 ft (1.2 m) of power cord on back of washer.
- Hot and cold water faucets located within 3 ft (0.9 m) of hot and cold water fill valves on washer, and water pressure of 20-100 psi (138-690 kPa).
- A level floor with maximum slope of 1" (25 mm) under entire washer. Installing on carpet is not recommended.
- Floor must support washer's total weight (with water and load) of 315 lbs (143 kgs).

IMPORTANT: Do not install, store or operate washer where it will be exposed to weather or in temperatures below 32° F (0° C). Water remaining in washer after use may cause damage in low temperatures. See "Washer Care" in your Use and Care Guide for winterizing information.

Proper installation is your responsibility.

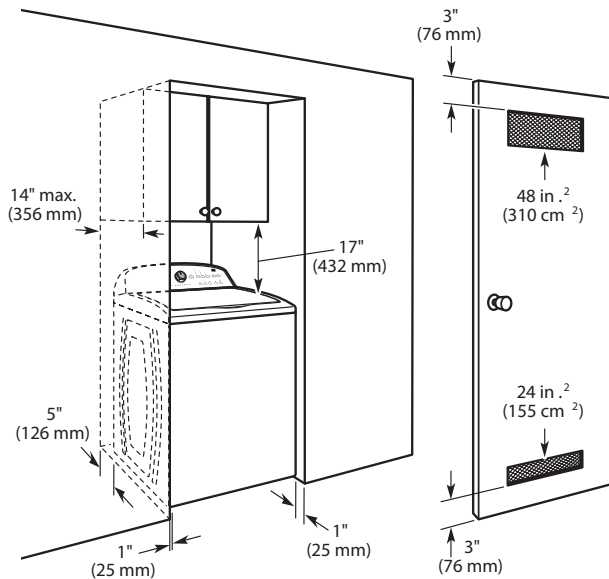

Recessed area or closet installation

Dimensions show recommended spacing allowed, except for closet door ventilation openings which are minimum required. This washer has been tested for installation with spacing of 0" (0 mm) clearance on the sides. Consider allowing more space for ease of installation and servicing; spacing for companion appliances and clearances for walls, doors and floor moldings. Add spacing of 1" (25 mm) on all sides of washer to reduce noise transfer. If a closet door or louvered door is installed, top and bottom air openings in door are required.

DRAIN SYSTEM

Drain system can be installed using a floor drain, wall standpipe, floor standpipe, or laundry tub. Select method you need.

Floor standpipe drain system

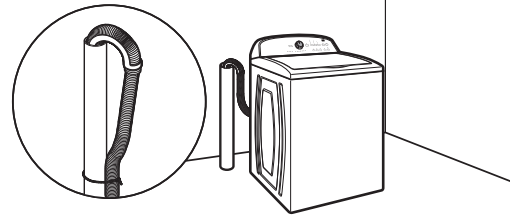

Minimum diameter for a standpipe drain: 2" (51 mm).
Minimum carry-away capacity: 17 gal. (64 L) per minute.
Top of standpipe must be at least 39" (990 mm) high; install no higher than 96" (2.44 m) from bottom of washer. If you must install higher than 96" (2.44 m), you will need a sump pump system.

Wall standpipe drain system

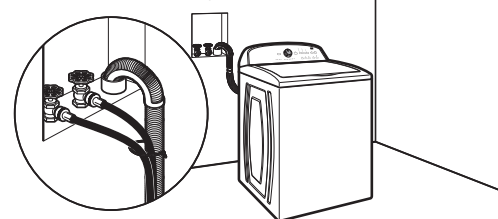

See requirements for floor standpipe drain system

Floor drain system

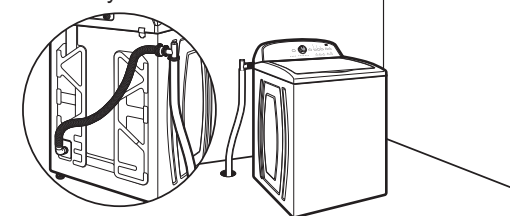

Floor drain system requires a Siphon Break Kit (Part Number 280129) and additional drain hose (Part Number 3357090) that may be purchased separately. To order, please see toll-free phone numbers in your Use and Care Guide. Minimum siphon break: 28" (710 mm) from bottom of washer. (Additional hoses may be needed.)

Laundry tub drain system

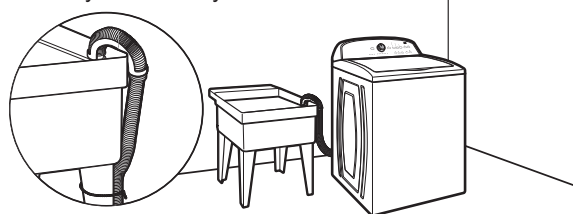

Minimum capacity: 20 gal. (76 L). Top of laundry tub must be at least 39" (990 mm) above floor; install no higher than 96" (2.44 m) from bottom of washer.

IMPORTANT: To avoid siphoning, no more than 4.5" (113 mm) of drain hose should be inside standpipe or below the top of wash tub. Secure drain hose with beaded tie strap.

INSTALLATION REQUIREMENTS (continued)

ELECTRICAL REQUIREMENTS

⚠ WARNING



Electrical Shock Hazard

Plug into a grounded 3 prong outlet.

Do not remove ground prong.

Do not use an adapter.

Do not use an extension cord.

Failure to follow these instructions can result in death, fire, or electrical shock.

- A 120 volt, 60 Hz., AC only, 15- or 20-amp, fused electrical supply is required. A time-delay fuse or circuit breaker is recommended. It is recommended that a separate circuit breaker serving only this appliance be provided.
- This washer is equipped with a power supply cord having a 3 prong grounding plug.
- To minimize possible shock hazard, the cord must be plugged into a mating, 3 prong, grounding-type outlet, grounded in accordance with local codes and ordinances. If a mating outlet is not available, it is the personal responsibility and obligation of the customer to have the properly grounded outlet installed by a qualified electrician.
- If codes permit and a separate ground wire is used, it is recommended that a qualified electrician determine that the ground path is adequate.
- Do not ground to a gas pipe.
- Check with a qualified electrician if you are not sure the washer is properly grounded.
- Do not have a fuse in the neutral or ground circuit.

GROUNDING INSTRUCTIONS

For a grounded, cord-connected washer:
This washer must be grounded. In the event of a malfunction or breakdown, grounding will reduce the risk of electrical shock by providing a path of least resistance for electric current. This washer is equipped with a cord having an equipment-grounding conductor and a grounding plug. The plug must be plugged into an appropriate outlet that is properly installed and grounded in accordance with all local codes and ordinances.

WARNING: Improper connection of the equipment-grounding conductor can result in a risk of electric shock. Check with a qualified electrician or serviceman if you are in doubt as to whether the appliance is properly grounded.

Do not modify the plug provided with the appliance – if it will not fit the outlet, have a proper outlet installed by a qualified electrician.

For a permanently connected washer:
This washer must be connected to a grounded metal, permanent wiring system, or an equipment grounding conductor must be run with the circuit conductors and connected to the equipment-grounding terminal or lead on the appliance.

INSTALLATION INSTRUCTIONS

⚠ WARNING

Excessive Weight Hazard

Use two or more people to move and install washer.

Failure to do so can result in back or other injury.

Before you start: remove shipping materials
It is necessary to remove all shipping materials for proper operation and to avoid excessive noise from washer.

1. Move washer

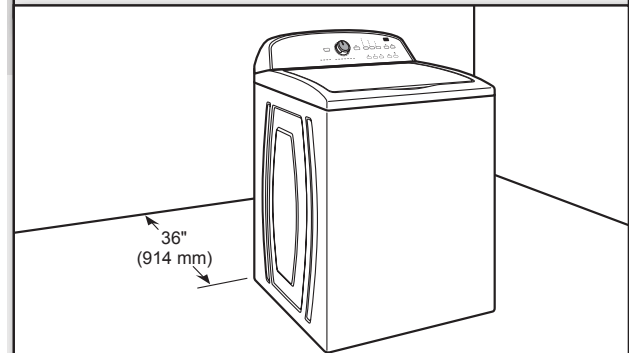

Move washer to within 3 ft (914 mm) of its final location, it must be in a fully upright position.

NOTE: To avoid floor damage, set washer onto cardboard before moving it and make sure lid is taped shut.

2. Remove shipping base

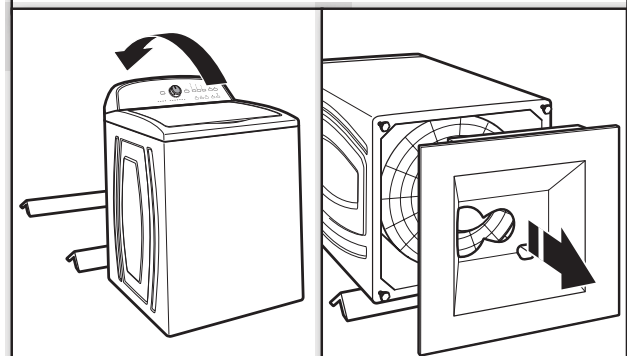

To avoid damaging floor, place cardboard supports from shipping carton on floor behind washer. Tip washer back and place on cardboard supports. Remove shipping base. Set washer upright.

IMPORTANT: Removing shipping base is necessary for proper operation. If your washer includes a sound shield, please refer to the instructions included with the sound shield to install it at this time.

INSTALLATION REQUIREMENTS (continued)

3. Remove packing tray from drum

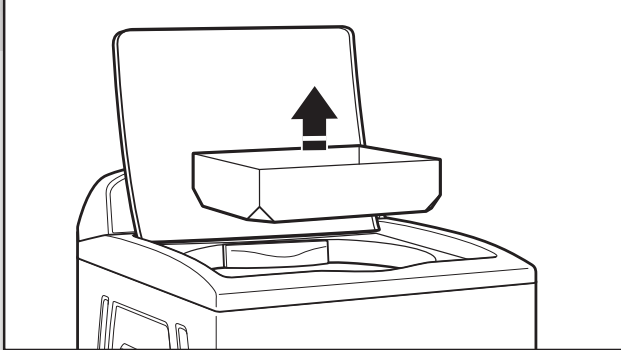

Remove tape from washer lid, open lid and remove cardboard packing tray from tub. Be sure to remove all parts from tray.

NOTE: Keep tray in case you need to move washer later.

4. Free power cord

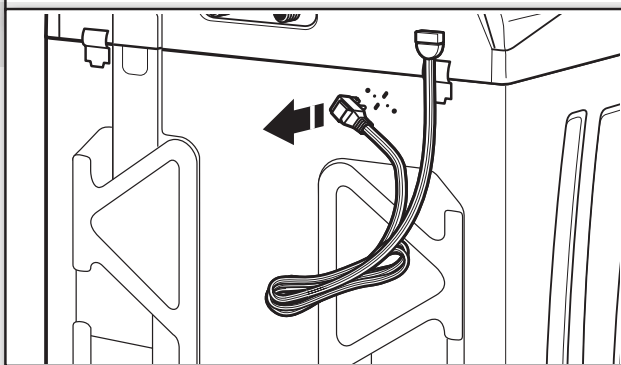

Firmly grasp power cord plug and pull to free from rear panel. Gently place power cord over console to allow free access to back of washer.

CONNECT DRAIN HOSE

5. Attach drain hose to drain port

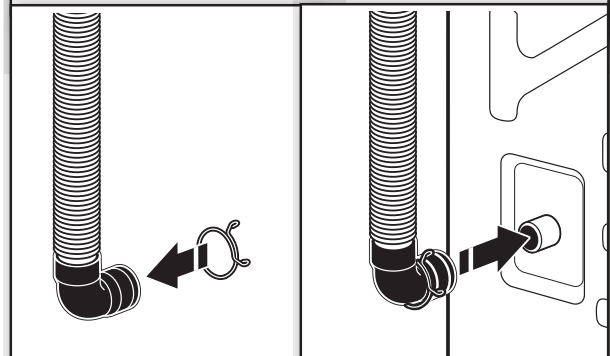

If clamp is not already in place on elbow end of drain hose, slide it over end as shown. Squeeze clamp with pliers and slide black elbow end of drain hose onto black drain port and secure with clamp.

For a laundry tub or standpipe drain, go to step 6.

For a floor drain, remove the preinstalled drain hose form as shown in Step 7. You may need additional parts with separate directions. See "Tools and Parts".

6. Place drain hose in standpipe

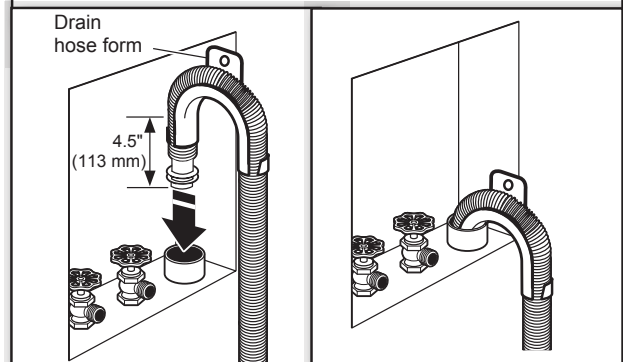

Place hose into standpipe (shown in picture) or over side of laundry tub.

IMPORTANT: 4.5" (113 mm) of drain hose should be inside standpipe; do not force excess hose into standpipe or lay on bottom of laundry tub. Drain hose form must be used.

INSTALLATION REQUIREMENTS (continued)

7. Remove drain hose form (floor drain installations only)

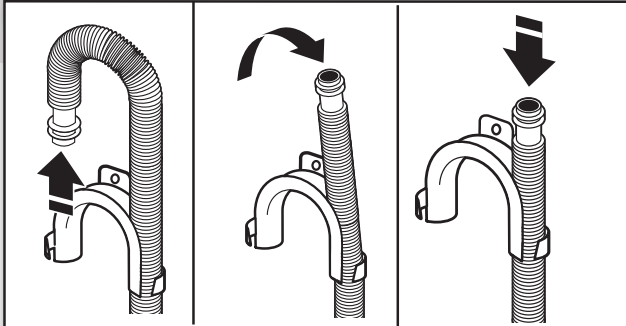

For floor drain installations, you will need to remove the drain hose form from the end of the drain hose. You may need additional parts with separate directions. See “Tools and Parts”.

CONNECT INLET HOSES

Washer must be connected to water faucets with new inlet hoses with flat washers (not provided). Do not use old hoses.

Both hoses must be attached and have water flowing to inlet valves. If you are only connecting to a cold water faucet, you must use a Y-adaptor (not provided).

8. Connect inlet hoses to water faucets

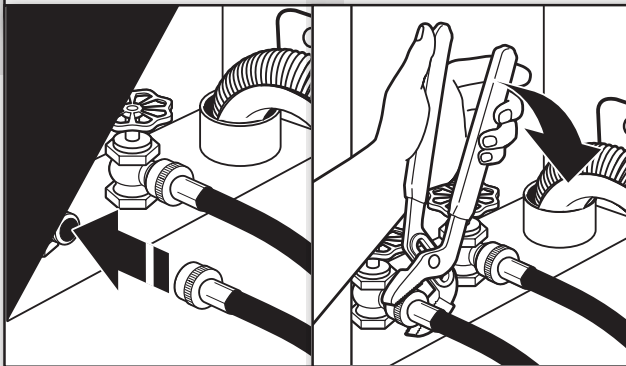

Attach hose to hot water faucet. Screw on coupling by hand until it is seated on washer. Use pliers to tighten couplings an additional two-thirds turn. Repeat this step with second hose for cold water faucet.

IMPORTANT: Do not overtighten or use tape or sealants on valve when attaching to faucets or washer. Damage can result.

HELPFUL TIP: Make note of which hose is connected to hot water to help in attaching hoses to washer correctly. In most standard configurations, hoses will cross over each other when attached correctly.

9. Clear water lines

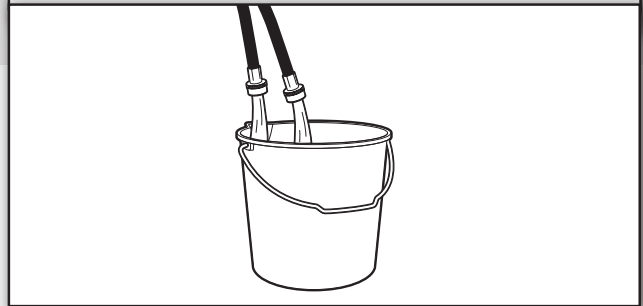

Run water for a few seconds through hoses into a laundry tub, drainpipe or bucket to prevent clogs. Water should run until clear.

10. Connect inlet hoses to washer

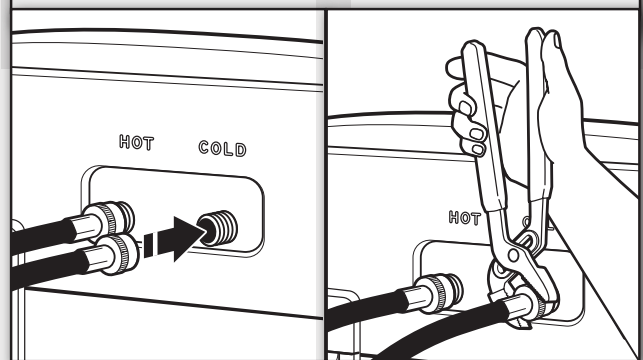

Attach hot water hose to hot water inlet valve marked with a red ring. Screw coupling by hand until it is snug. Use pliers to tighten couplings an additional two-thirds turn. Repeat with cold water inlet valve.

IMPORTANT: To reduce risk of hose failure, replace the hoses every 5 years. Record hose installation or replacement dates for future reference.

- Periodically inspect and replace hoses if bulges, kinks, cuts, wear, or leaks are found.

11. Check for leaks

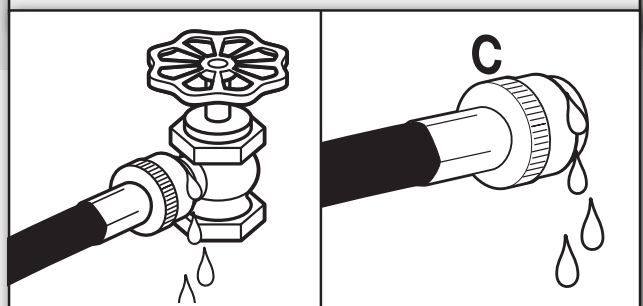

Turn on water faucets to check for leaks. A small amount of water may enter washer. It will drain later.

INSTALLATION REQUIREMENTS (continued)

12. Secure drain hose

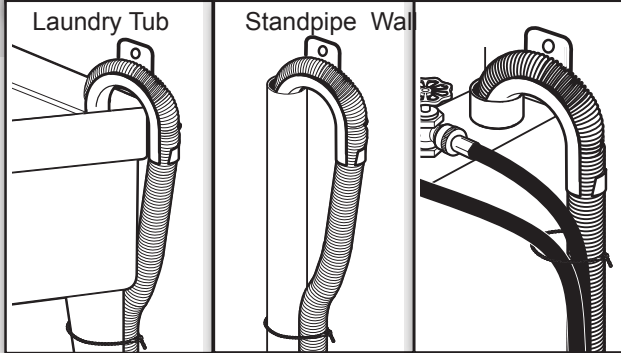

Secure drain hose to laundry tub leg, drain standpipe or inlet hoses for wall standpipe with beaded tie strap.

LEVEL WASHER

IMPORTANT: Level washer properly to reduce excess noise and vibration.

13. Check levelness of washer

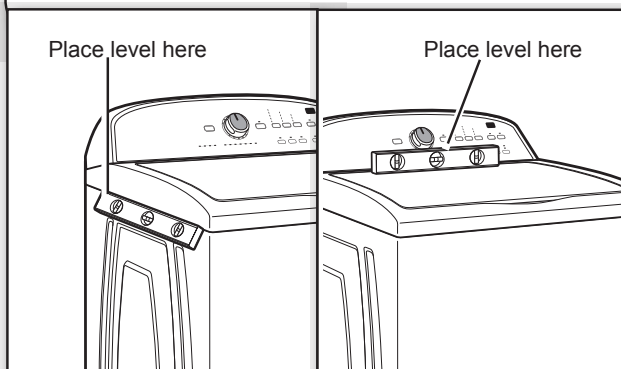

With washer in its final location, place a level on top edges of washer. Use side seam as a guide to check levelness of sides. Check levelness of front using lid, as shown. Rock washer back and forth to make sure all four feet make solid contact with floor. If washer is level, skip to step 14.

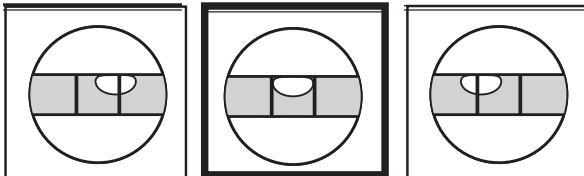

Not Level

LEVEL

Not Level

14. Adjust leveling feet

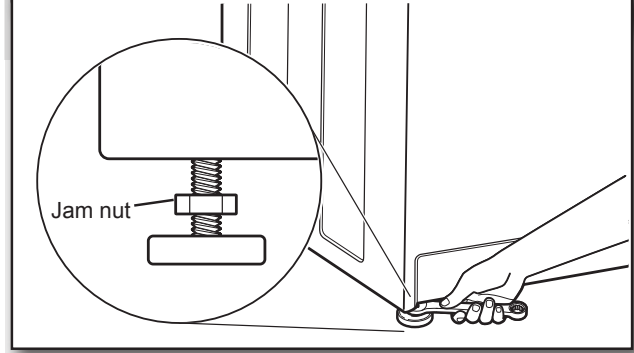

If washer is not level, use a 9/16" or 14 mm open-end or adjustable wrench to turn jam nuts clockwise on foot until they are about 1/2" (13 mm) from the washer cabinet. Then turn the leveling foot clockwise to lower the washer or counterclockwise to raise the washer. Recheck levelness of washer and repeat as needed.

HELPFUL TIP: You may want to prop up front of washer about 4" (102 mm) with a wood block or similar object that will support weight of washer.

15. Tighten leveling feet

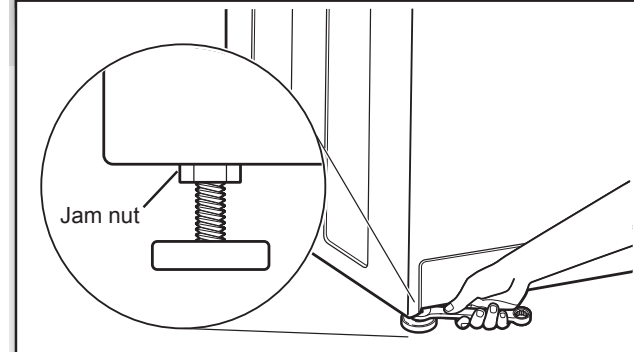

When washer is level, use a 9/16" or 14 mm open-end or adjustable wrench to turn jam nuts counterclockwise on leveling feet tightly against washer cabinet.

HELPFUL TIP: You may want to prop washer with wooden block.

PRODUCT OPERATION

THEORY OF OPERATION

INTRODUCTION

The VMW Vertical Modular Washer represents several familiar features from prior designs. It utilizes and improves on the best systems from prior Whirlpool top load automatic washer designs and integrates them into this new design.

DRIVE SYSTEM

Motor – Bi-directional PSC (Permanent Split Capacitor) 120VAC. Agitation and variable spin speeds are accomplished by applying power in pulses.

Transmission – The transmission is a non-serviceable belt driven component.

- Inner shaft top splines connect to the agitator.
- Bottom splines connect to the splutch pulley.
- Outer shafts top splines connect to the basket.
- Bottom splines connect to the inner splines of the splutch cam.

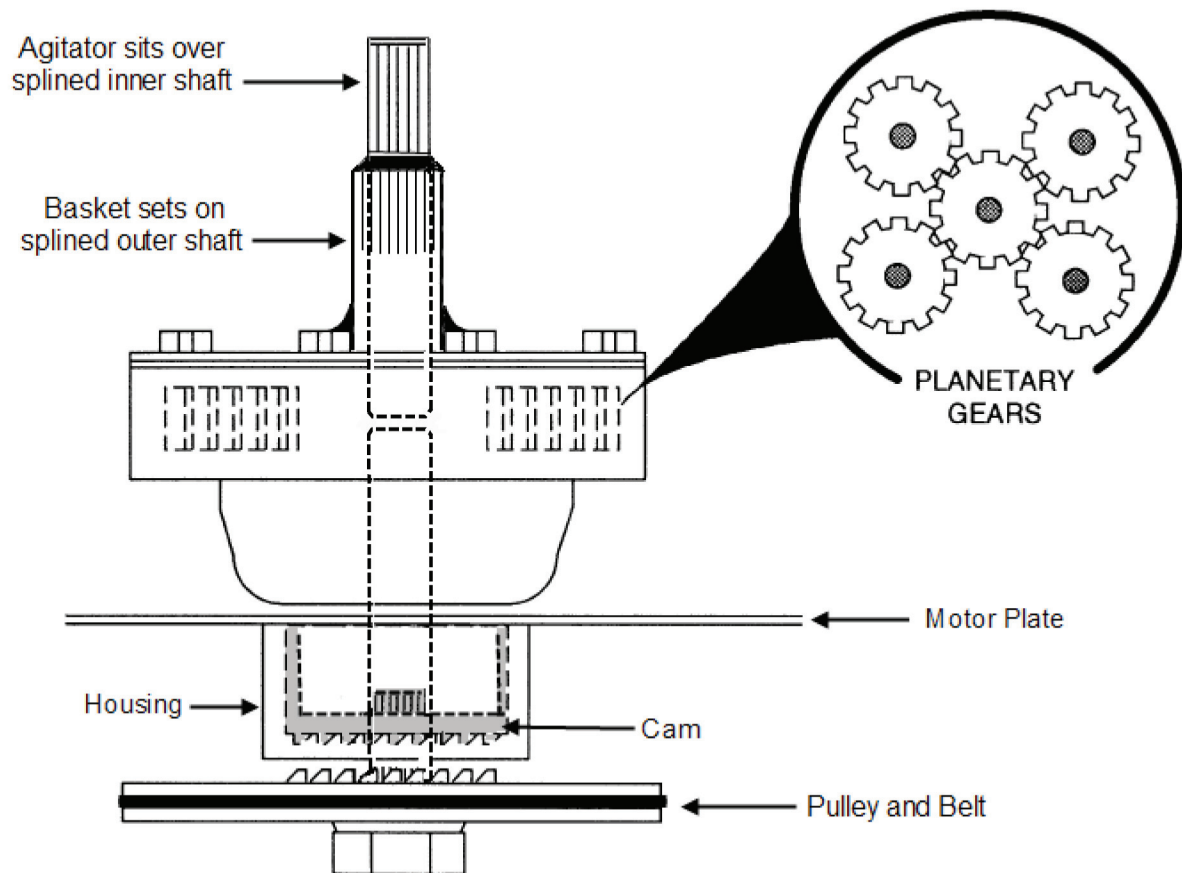

Splutch – The splutch is made up of five parts; a spring, housing, cam ring, basket drive gear and pulley. The pulley is connected to the agitator through the agitator shaft. The agitator always moves with the pulley. The basket drive gear is connected to the basket by the inner splines contacting the outer splines of the transmission. The cam ring raises and lowers the basket drive gear. When the basket drive gear teeth are engaged to the pulley teeth the basket will spin along with the agitator.



Spring

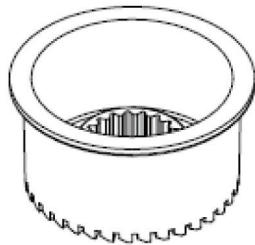

Basket Drive Gear

Inner splines - connect to transmission (and basket)
Outer teeth - connect to pulley

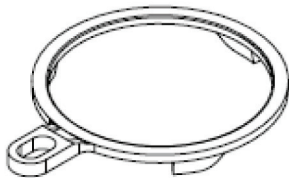

Cam Ring

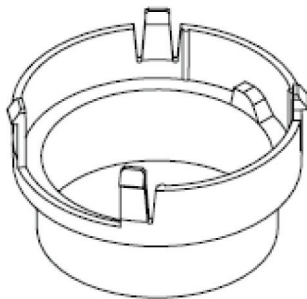

Housing

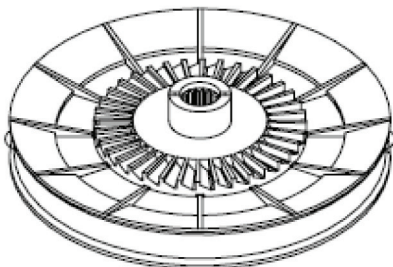

Pulley

Inner splines - connect to agitator shaft
Outer teeth - connect to Basket Drive Gear

LID LOCK MECHANISM

Since this washer does not utilize a brake, a lid lock is used to prevent access during use. During a cycle, a lid lock mechanism will lock the lid. The lid must be closed for the machine to fill, wash, drain, or spin. The mechanism houses a switch that senses that the lid is down, a latch solenoid and a switch to confirm that the lid is locked.

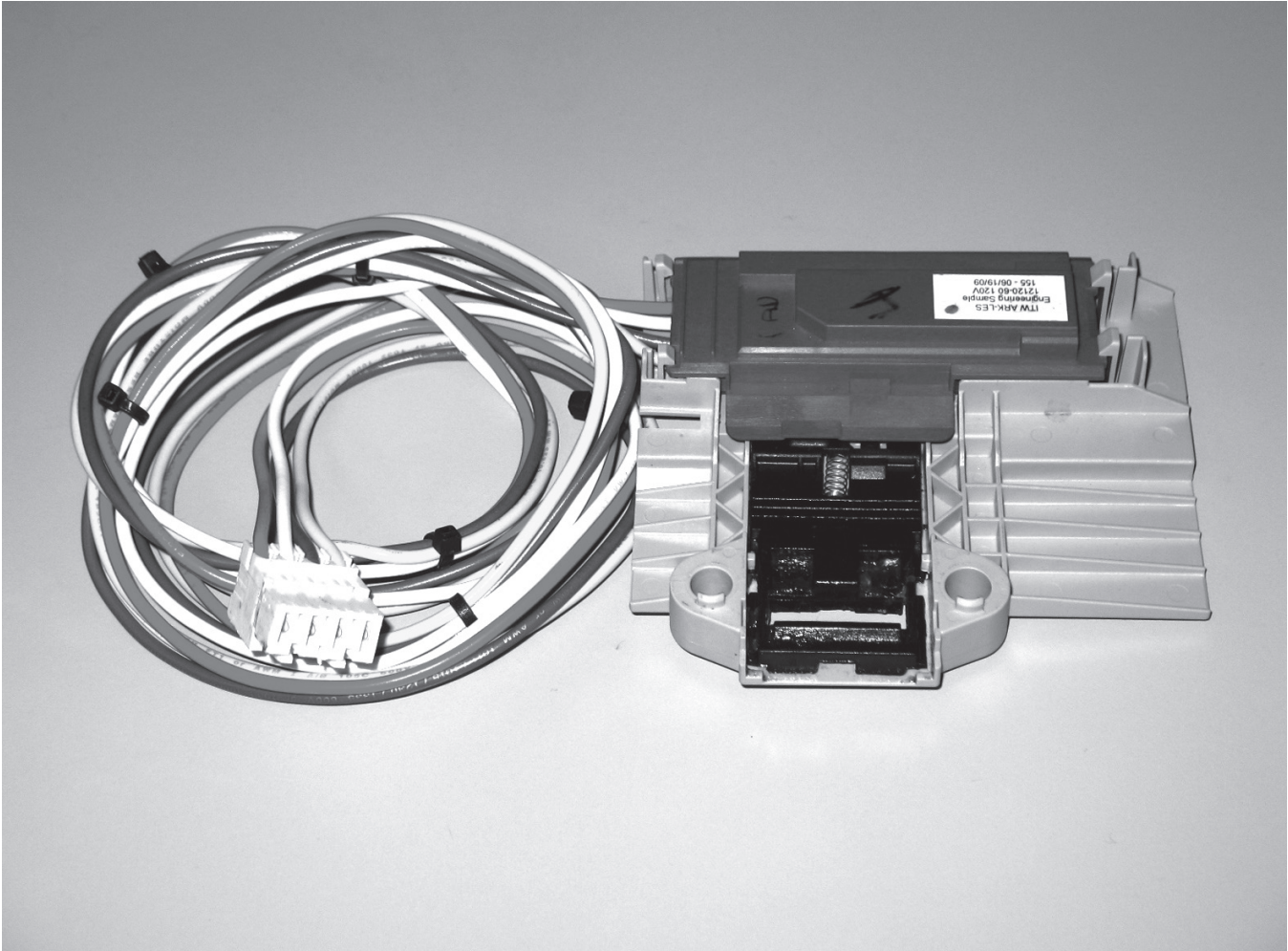

CONTROL PANEL AND FEATURES

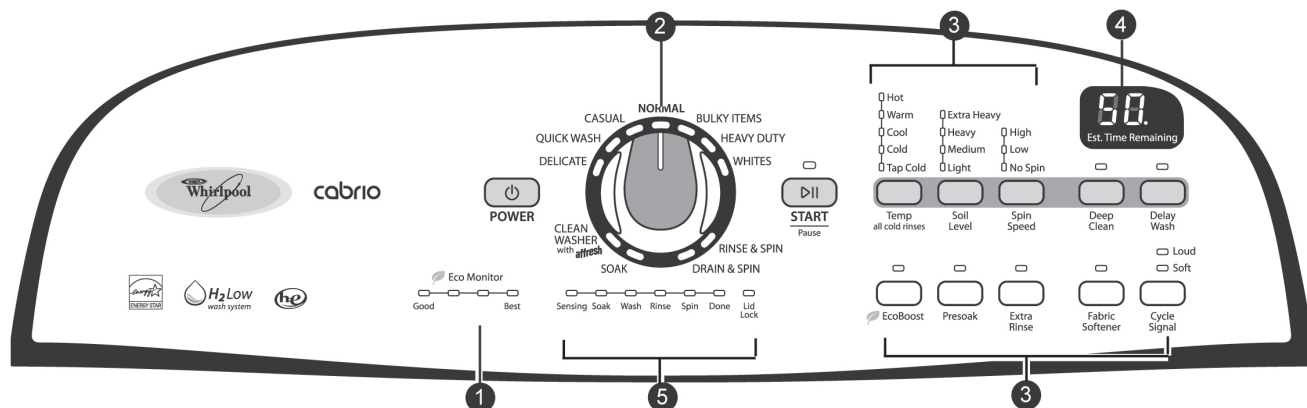

ECO MONITOR

Your washer is specially designed to conserve energy and water. Each cycle, along with any selected options, will result in different energy and water usage. As you make your cycle and temperature selections, the Eco Monitor shows how well you are saving energy and water.

WASH CYCLE KNOB

Use the Wash Cycle Knob to select available cycles on your washer. Turn the knob to select a cycle for your laundry load. See “Cycle Guide” for detailed descriptions of cycles.

CYCLE OPTIONS

When you select a cycle, its default settings will light up.

TEMP

Temperature Control senses and maintains uniform water temperatures by regulating incoming hot and cold water.

Select a wash temperature based on the type of fabric and soils being washed. For best results and following the garment label instructions, use the warmest wash water safe for your fabric.

- Warm and hot water will be cooler than what your previous washer provided.
- Even in Cool wash, some warm water may be added to the washer to maintain a minimum temperature.

SOIL LEVEL

Soil level (wash time) is preset for each wash cycle. As you press Soil Level, the cycle time (minutes) will increase or decrease in the Estimated Time Remaining display and a different wash time will appear.

For most loads, use the soil level that is preset with the cycle you have chosen. For heavily soiled and sturdy fabrics, press Soil Level to select more wash time, if needed. For lightly soiled and delicate fabrics, press Soil Level to select less wash time, if needed. Lower soil level setting will help reduce tangling and wrinkling.

SPIN SPEED

This washer automatically selects the spin speed based on the cycle selected. The preset speeds can be changed. Not all spin speeds are available with all cycles.

- Faster spin speeds mean shorter dry times, but may increase wrinkling in your load.
- Slower spin speeds mean less wrinkling, but will leave your load more damp.

You may also add or remove options for each cycle.

Note: that not all options can be used with all cycles, and some are preset to work with certain cycles.

CONTROL PANEL AND FEATURES (continued)

DEEP CLEAN

This option provides enhanced cleaning action for tough stains. It will add additional time to the cycle. Deep Clean should be started on a dry load only and must be selected before tub has started to fill.

DELAY WASH

If you would like to set your washer to start at a preferred time, select the Delay Wash Option. You can use this option to delay start of a wash cycle for up to 10 hours (depending on model). Press Delay Wash button once to delay 1 hour. If you want a longer delay period, press and hold the button until your desired delay time (in hours) shows in the Estimated Time Remaining display. Then press START/PAUSE. The countdown to the wash cycle will show in the display window.

ECOBOOST

The EcoBoost option allows you to increase your energy savings on your wash cycles. When this option is used, the wash cycle will use cooler wash water than the selected cycle and may increase the spin speed for faster drying.

PRESOAK

Use this option to add an extra soak period to any cycle when washing heavily soiled garments.

EXTRA RINSE

This option can be used to automatically add a second rinse to most cycles.

FABRIC SOFTENER

This option must be selected if using fabric softener during a cycle. It ensures that fabric softener is added at the correct time in the rinse for even distribution.

CYCLE SIGNAL

Use this option to adjust volume of the signal that sounds at end of cycle. A louder signal is helpful in removing items as soon as cycle is complete.

Press and hold Cycle Signal for 5 seconds to turn the button sounds off or on.

EST TIME REMAINING DISPLAY

The Estimated Time Remaining display shows the time required for the cycle to complete. Factors such as load size and water pressure may affect the time shown in the display. Overloading, unbalanced loads, or excessive suds may cause the washer to adjust the cycle time, as well.

CYCLE STATUS LIGHTS INDICATOR

The Cycle Status Lights shows the progress of a cycle. At each stage of the process, you may notice sounds or pauses that are different from traditional washers.

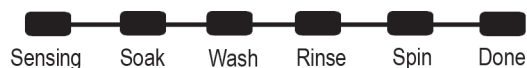

SENSING

When the START button is pressed, the washer will first perform a self-test on the lid lock mechanism. You will hear a click, the basket will make a slight turn, and the lid will unlock briefly before locking again. Once the lid has locked the second time, the washer will slowly spin the dry load to estimate the load size, and begin adding water. The washer will then move the load briefly, pause to allow water to soak in to the load, and resume adding water. This process may repeat until the correct amount of water has been added for the load. You may also hear water flowing through the dispenser, adding detergent to the load.

NOTE: The sensing light may also come on during the Soak and Wash portions of the cycle. This is normal.

CONTROL PANEL AND FEATURES (continued)

SOAK

This portion of the cycle allows water to soak into the load for optimal cleaning.

WASH

You will hear the impeller moving the load. Unlike traditional washers, the load is not covered with water. Low-water cleaning means concentrated cleaning. Rather than diluting detergent as done in an agitator-style washer, this washer delivers the detergent directly to the soils. The motor sounds may change at different stages in the cycle. The wash time is determined by the selected soil level.

RINSE

You will hear sounds similar to the wash cycle as the washer rinses and moves the load. Fabric softener will be added if the Fabric Softener option was selected.

SPIN

The washer spins the load at increasing speeds for proper water removal, based on the selected cycle and spin speed.

DONE

Once the cycle is complete, this light will come on.

Remove the load promptly for best results.

LID LOCK



This light indicates that the lid is locked and cannot be opened.

If you need to open the lid, press START/PAUSE. The lid will unlock once the washer movement has stopped. This may take several minutes if the load was spinning at high speed. Press START/PAUSE again to restart the cycle.

CYCLE GUIDE

Settings and options shown in **bold** are default settings for that cycle.
 For best fabric care, choose the cycle that best fits the load being washed.
 If using the Eco Monitor, adjust the temperature and spin speed within that cycle to improve energy usage.

Not all cycles and options are available on all models.

Items to wash:	Cycle:	Wash/Rinse Temperature:	Spin Speed:	Soil Level:	Available Options:	Cycle Details:
Machine-wash silks, hand-wash fabrics	Delicates	Hot/Cold Warm/Cold Cool/Cold Cold/Cold Tap Cold/Cold	High Low No Spin	Extra Heavy Heavy Medium Light	Deep Clean Extra Rinse Delay Wash Eco Presoak	Use this cycle to wash lightly soiled garments indicating "Machine Washable Silks" or "Gentle" cycle on the care label. Place small items in mesh garment bags before washing.
Small loads, cottons, polyester, perm press	Quick Wash	Hot/Cold Warm/Cold Cool/Cold Cold/Cold Tap Cold/Cold	High Low No Spin	Extra Heavy Heavy Medium Light	Deep Clean Extra Rinse Delay Wash Eco Presoak	Use this cycle to wash small, lightly soiled loads of 2-3 items that are needed in a hurry.
No-iron fabrics, cottons, perm press, linens, synthetics	Casual	Hot/Cold Warm/Cold Cool/Cold Cold/Cold Tap Cold/Cold	High Low No Spin	Extra Heavy Heavy Medium Light	Deep Clean Extra Rinse Delay Wash Eco Presoak	Use this cycle to wash loads of no-iron fabrics such as sport shirts, blouses, casual business clothes, permanent press, and blends.
Cottons, linens, and mixed garment loads	Normal	Hot/Cold Warm/Cold Cool/Cold Cold/Cold Tap Cold/Cold	High Low No Spin	Extra Heavy Heavy Medium Light	Deep Clean Extra Rinse Delay Wash Eco Presoak	Use this cycle for normally soiled cottons and mixed fabric loads.
Large items such as sleeping bags, small comforters, jackets	Bulky Items	Hot/Cold Warm/Cold Cool/Cold Cold/Cold Tap Cold/Cold	High Low No Spin	Extra Heavy Heavy Medium Light	Extra Rinse Delay Wash Eco Presoak	Use this cycle to wash large items such as jackets and small comforters. The washer will fill with enough water to wet down the load before the wash portion of the cycle begins. Do not overload basket.
Sturdy fabrics, colorfast items, towels, lightly-soiled colored clothing	Heavy Duty	Hot/Cold Warm/Cold Cool/Cold Cold/Cold Tap Cold/Cold	High Low No Spin	Extra Heavy Heavy Medium Light	Deep Clean Extra Rinse Delay Wash Eco Presoak	Use this cycle for heavily soiled or sturdy items. Water-level sensing process may take longer for some items than for others because they will absorb more water than other fabric types.
Heavily soiled white fabrics	Whites	Hot/Cold Warm/Cold Cool/Cold Cold/Cold Tap Cold/Cold	High Low No Spin	Extra Heavy Heavy Medium Light	Deep Clean Extra Rinse Delay Wash Eco Presoak	Extra Rinse is a default option, but may be turned off. For maximum soil removal use liquid chlorine bleach.
Swimsuits	Rinse & Spin	Hot/Cold Warm/Cold Cool/Cold Cold/Cold Tap Cold/Cold	High Low No Spin			Combines a deep rinse and high speed spin for loads requiring an additional rinse cycle or to complete a load after power interruption. Also use for loads that require rinsing only.

ADDITIONAL CYCLES

Drain & Spin

This cycle uses a high-speed spin to shorten drying times for heavy fabrics or special-care items. Use this cycle to drain washer after cancelling a cycle or completing a cycle after a power failure.

NOTE: Do not add detergents or bleach products when running this cycle.

Soak

Select Soil Level to adjust soaking cycle time. After time has expired, water will drain but washer will not spin.

NOTE: Automatic bleach dispensing is not part of soak cycle.

Clean Washer with AFFRESH®

Use this cycle monthly to keep washer drum fresh and clean. Higher water levels combined with AFFRESH™ help eliminate odors and mildew. See Washer Maintenance for more details.

IMPORTANT: Make sure washer is empty before selecting this cycle.

USING THE WASHER

⚠️ WARNING



Fire Hazard

Never place items in the washer that are dampened with gasoline or other flammable fluids.

No washer can completely remove oil.

Do not dry anything that has ever had any type of oil on it (including cooking oils).

Doing so can result in death, explosion, or fire.

⚠️ WARNING



Electrical Shock Hazard

Plug into a grounded 3 prong outlet.

Do not remove ground prong.

Do not use an adapter.

Do not use an extension cord.

Failure to follow these instructions can result in death, fire, or electrical shock.

1. Sort and prepare your laundry

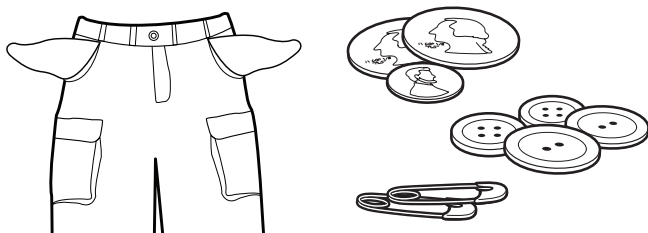

- Empty pockets. Loose change, buttons, or any small object can pass under the impeller and become trapped, causing unexpected sounds.
- Sort items by recommended cycle, water temperature, and colorfastness.
- Separate heavily soiled items from lightly soiled.
- Separate delicate items from sturdy fabrics.
- Do not dry garments if stains remain after washing, because heat can set stains into fabric.
- Treat stains promptly.
- Close zippers, fasten hooks, tie strings and sashes, and remove non-washable trim and ornaments.
- Mend rips and tears to prevent further damage to items during washing.

Helpful Tips:

- When washing water-proof or water-resistant items, load evenly. See "Cycle Guide" for tips and more information on using the Bulky Items cycle.
- Use garment bags to help prevent tangling when washing delicate or small items.
- Turn knits inside out to prevent pilling. Separate lint-takers from lint-givers. Synthetics, knits, and corduroy fabrics will pick up lint from towels, rugs, and chenille fabrics.

2. Load laundry into washer

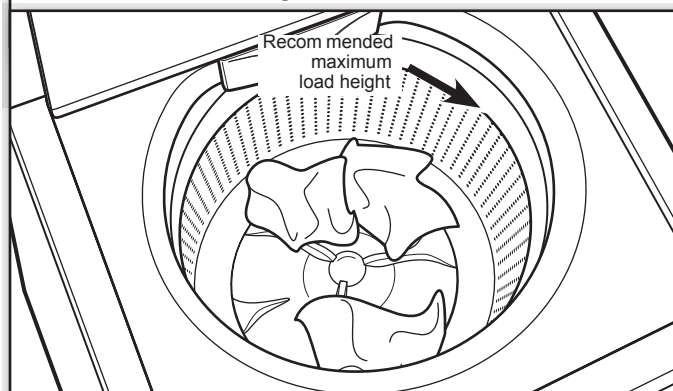

Load garments in loose heaps evenly around basket wall. For best results, do not load higher than the recommended maximum load height. Try mixing different sized items to reduce tangling.

IMPORTANT: Do not overload washer. Items need to move freely. Overloading can lead to poor cleaning performance, and may increase wrinkling and tangling.

Always read and follow fabric care labels instructions to avoid damage to your garments.

USING LAUNDRY PRODUCT DISPENSERS

3. Add HE detergent to dispenser

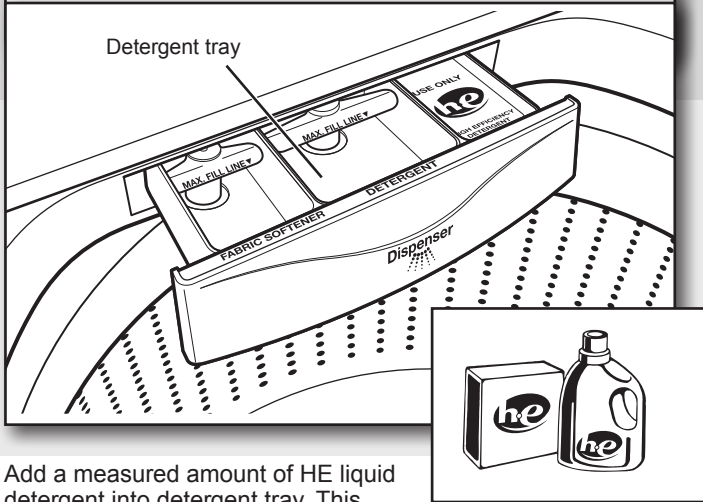

Add a measured amount of HE liquid detergent into detergent tray. This tray holds 3 oz. (89 mL). Do not overfill tray - adding too much detergent may cause detergent to be dispensed into the washer too early.

IMPORTANT: Use only High Efficiency detergents. The package will be marked "HE" or "High Efficiency." Low-water washing creates excessive sudsing with a regular non-HE detergent. Using regular detergent will likely result in longer cycle times and reduced rinsing performance. It may also result in component failures and noticeable mold or mildew. HE detergents are made to produce the right amount of suds for the best performance. Follow the manufacturer's instructions to determine the amount of detergent to use.

NOTE: If using an Oxi laundry boost product, add to the bottom of the washer basket before adding clothes.

HELPFUL TIP: See "Washer Maintenance" for information on recommended method of cleaning washer dispenser trays.

5. Add fabric softener to dispenser

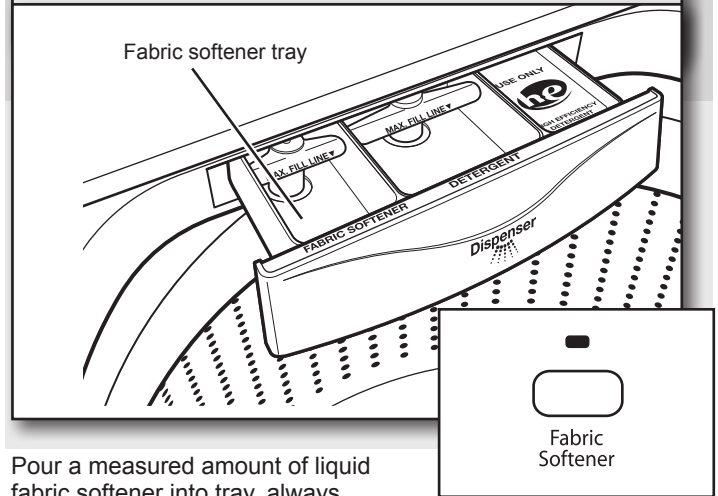

Pour a measured amount of liquid fabric softener into tray, always follow manufacturer's directions for correct amount of fabric softener based on your load size. Then select Fabric Softener option.

IMPORTANT: Fabric Softener option must be selected to ensure proper distribution at correct time in cycle. Do not overfill or dilute. Overfilling dispenser will cause fabric softener to immediately dispense into washer. If Extra Rinse option is selected, fabric softener will be dispensed into the last rinse.

NOTE: Do not use liquid fabric softener dispenser balls in this washer. They will not dispense correctly.

4. Add liquid chlorine bleach to dispenser

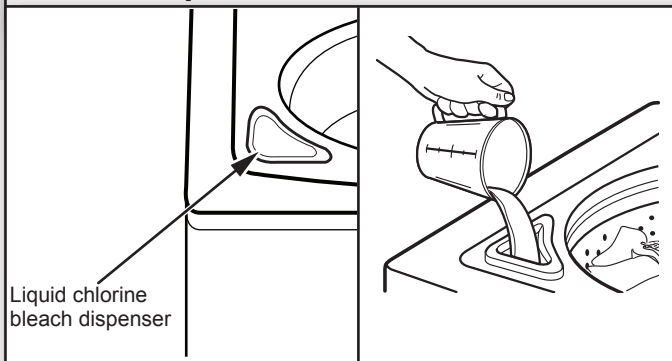

Do not overfill, dilute, or use more than 1 cup (250 mL). Do not use color-safe bleach or Oxi products in the same cycle with liquid chlorine bleach.

Starting Your Washer

6. Press POWER to turn on washer



USING LAUNDRY PRODUCT DISPENSERS (continued)

7. Select cycle

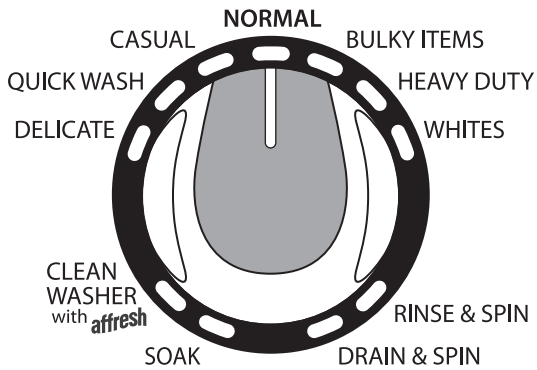

Turn cycle knob to choose your wash cycle. When knob is lined up with a cycle, you will hear a clicking sound. Indicator for Estimated Time Remaining will light up with a cycle time. For more information, see "Control Panel".



If you do not want to begin a cycle immediately, you may choose DELAY WASH option.

To change delay time:

1. Press START/PAUSE.
2. Press DELAY WASH button to select desired start time.
3. Press START/PAUSE.



To cancel delaying a cycle:

Press START/PAUSE again to begin a wash cycle immediately. **IMPORTANT:** When delaying a cycle, use liquid HE detergent only in the detergent dispenser tray. Powdered detergents may absorb moisture from a previous cycle and clump before the wash cycle begins.

8. Select cycle settings

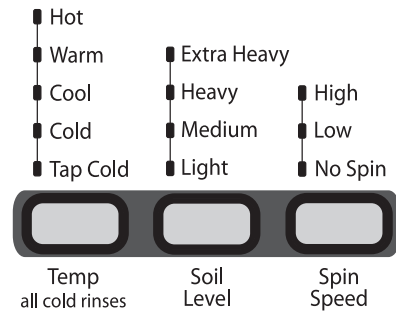

Once you select a cycle, the default settings for that cycle will be lit. Press the cycle settings buttons to change the Temperature, Soil Level, and Spin Speed, if desired.

Always read and follow fabric care labels instructions to avoid damage to your garments.

Wash Temp	Suggested Fabrics
Hot Some cold water is added to save energy. This will be cooler than your hot water heater setting.	Whites and pastels Durable garments Heavy soils
Warm Some cold water will be added, so this will be cooler than what your previous washer provided.	Bright colors Moderate to light soils
Cool - brights/darks Warm water is added to assist in soil removal and to help dissolve detergents.	Colors that bleed or fade Light soils
Cold Warm water may be added to assist in soil removal and to help dissolve detergents.	Dark colors that bleed or fade Light soils
Tap Cold This is the temperature from your faucet.	Dark colors that bleed or fade Light soils

USING LAUNDRY PRODUCT DISPENSERS (continued)

9. Select cycle options

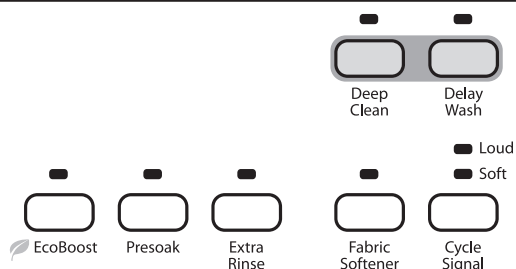

Select any other cycle options you may wish to add, if not previously set. Some cycles will automatically add certain options such as Presoak or Extra Rinse. These can be turned off, if desired.

NOTE: Not all options are available with all cycles.

10. Select START/PAUSE to begin wash cycle



Press the START/PAUSE button to start the wash cycle. When the cycle has finished, the DONE indicator will light and the end of cycle signal will sound (if set). Promptly remove garments after cycle has completed to prevent odor, reduce wrinkling, and rusting of metal hooks, zippers, and snaps.

NOTE:

If you need to open the lid to add 1 or 2 missed garments, you may do so while the Add a Garment indicator is lit.

Press START/PAUSE; the lid will unlock once the washer movement has stopped. This may take several minutes if the load was spinning at high speed. Then close lid and press START/PAUSE again to restart the cycle.

If lid is left open for more than 10 minutes the water will pump out.

WASHER MAINTENANCE

WATER INLET HOSES

Replace inlet hoses after 5 years of use to reduce the risk of hose failure. Periodically inspect and replace inlet hoses if bulges, kinks, cuts, wear, or leaks are found.

When replacing your inlet hoses, mark the date of replacement on the label with a permanent marker.

CLEANING YOUR WASHER

Keep your washer as clean and fresh as your clothes. To keep washer interior odor-free, follow this recommended monthly cleaning procedure:

1. Make sure the washer is empty.
2. Using recommended AFFRESH™ washer cleaner, add one tablet to washer drum

OR

If using liquid chlorine bleach, add 1 cup (250 mL) to liquid chlorine bleach dispenser.

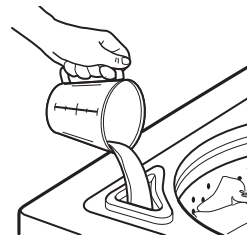

IMPORTANT: Do not add detergent to CLEAN WASHER with AFFRESH cycle. Do not use more than recommended amount of bleach to avoid damaging product over time.

3. Close washer lid.
4. Press POWER.
5. Select CLEAN WASHER with AFFRESH cycle.
6. Press START/PAUSE. Water will pour into washer for a moment and pause, lid will lock, then cycle will continue.

NOTE: For best results, do not interrupt cycle. If cycle must be interrupted, press START/PAUSE twice and run a RINSE AND SPIN cycle to ensure cleaner or bleach have been rinsed from washer.

To clean exterior:

1. Use a soft, damp cloth or sponge to wipe up any spills.
2. Use all-purpose surface cleaner, if needed.

IMPORTANT: To avoid damaging the washer's finish, do not use abrasive products.

USING LAUNDRY PRODUCT DISPENSERS (continued)

CLEANING YOUR DISPENSER TRAY

You may find laundry product residue leftover in your dispenser trays. To remove residue, follow this recommended cleaning procedure:

1. Pull tray out until you feel resistance.
2. Lift up slightly, and then continue pulling out.
3. Wash in warm, soapy water, using a mild detergent.
4. Rinse with warm water.
5. Air dry, or dry with a towel, then place back into slot.

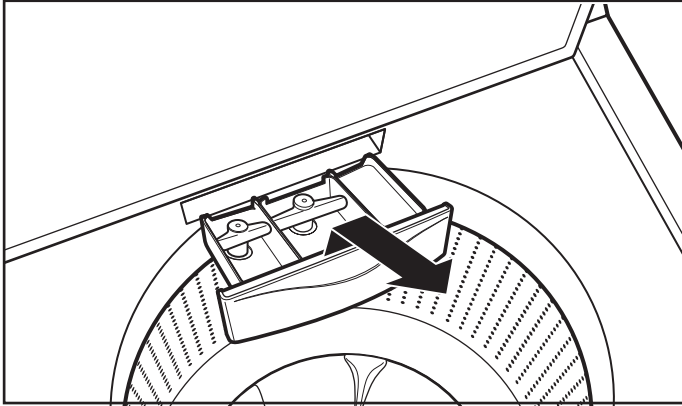

IMPORTANT: Dispenser trays are not dishwasher safe.

NON-USE AND VACATION CARE

Operate your washer only when you are home. If moving, or not using your washer for a period of time, follow these steps:

1. Unplug or disconnect power to washer.
2. Turn off water supply to washer, to avoid flooding due to water pressure surge.

WINTER STORAGE CARE

IMPORTANT: To avoid damage, install and store washer where it will not freeze. Because some water may stay in hoses, freezing can damage washer. If storing or moving during freezing weather, winterize your washer.

To winterize washer:

1. Shut off both water faucets, disconnect and drain water inlet hoses.
2. Put 1 qt. (1 L) of R.V.-type antifreeze in basket and run washer on RINSE AND SPIN cycle for about 30 seconds to mix antifreeze and remaining water.
3. Unplug washer or disconnect power.

TRANSPORTING YOUR WASHER

1. Shut off both water faucets. Disconnect and drain water inlet hoses.
2. If washer will be moved during freezing weather, follow WINTER STORAGE CARE directions before moving.
3. Disconnect drain from drain system and drain any remaining water into a pan or bucket. Disconnect drain hose from back of washer.
4. Unplug power cord.
5. Place inlet hoses and drain hose inside washer basket.
6. Drape power cord over edge and into washer basket.
7. Place packing tray from original shipping materials back inside washer. If you do not have packing tray, place heavy blankets or towels into basket opening. Close lid and place tape over lid and down front of washer. Keep lid taped until washer is placed in new location.

REINSTALLING/USING WASHER AGAIN

To reinstall washer after non-use, vacation, winter storage or moving:

1. Refer to Installation Instructions to locate, level, and connect washer.
2. Before using again, run washer through the following recommended procedure:

To use washer again:

1. Flush water pipes and hoses. Reconnect water inlet hoses. Turn on both water faucets.

⚠ WARNING



Electrical Shock Hazard

Plug into a grounded 3 prong outlet.

Do not remove ground prong.

Do not use an adapter.

Do not use an extension cord.

Failure to follow these instructions can result in death, fire, or electrical shock.

2. Plug in washer or reconnect power.
3. Run washer through BULKY ITEMS cycle to clean washer and remove antifreeze, if used. Use only HE High Efficiency detergent. Use half the manufacturer's recommended amount for a medium-size load.

TROUBLESHOOTING

First try the solutions suggested here or visit our website at www.whirlpool.com/help for assistance and to possibly avoid a service call.

If you experience	Possible Causes	Solution
Vibration or Off-Balance		
Check the following for proper installation or see "Getting Started" section.	Feet may not be in contact with the floor and locked.	Front and rear feet must be in firm contact with floor, and washer must be level to operate properly. Jam nuts must be tight against the bottom of the cabinet.
	Washer may not be level.	Check floor for flexing or sagging. If flooring is uneven, a 3/4" (19 mm) piece of plywood under your washer will reduce sound. See "Level the Washer" in Installation Instructions.
	Load could be unbalanced.	Load dry items in loose heaps evenly around basket wall. Adding wet items to washer or adding more water to basket could unbalance washer.
		Do not overload. Do not fill above the stainless steel portion of basket. Avoid washing single items.
Use Bulky Item cycle for oversized, non-absorbent items such as comforters or poly-filled jackets. See "Cycle Guide" and "Using Your Washer" in this Use and Care Guide.		
Noises		
Clicking or metallic noises	Objects caught in washer drain system.	Empty pockets before washing. Loose items such as coins could fall between basket and tub or may block pump. It may be necessary to call for service to remove items.
		It is normal to hear metal items on clothing such as metal snaps, buckles, or zippers touch against the stainless steel basket.
Gurgling or humming	Washer may be draining water.	It is normal to hear the pump making a continuous humming sound with periodic gurgling or surging as final amounts of water are removed during the spin/drain cycles.
Water Leaks		
Check the following for proper installation:	Washer not level.	Water may splash off basket if washer is not level. Check that load is not unbalanced or overloaded.
	Fill hoses not attached tightly.	Tighten fill-hose connection.
	Fill hose washers	Are all four fill hose flat washers properly seated?
	Drain hose connection	Pull drain hose from washer cabinet and properly secure it to drainpipe or laundry tub.
		Do not place tape over drain opening.
	Check household plumbing for leaks or clogged sink or drain	Water can backup out of a clogged sink or drainpipe. Check all household plumbing for leaks (laundry tubs, drain pipe, water pipes, and faucets.)
Washer not loaded properly.	Improper loading can cause basket to be out of alignment and cause water to splash off tub. See "Getting Started" for loading instructions.	
Washer not performing as expected		
Not enough water in washer	Load not completely covered in water.	This is normal operation for an HE low-water washer. The load will not be completely underwater. The washer senses load sizes and adds correct amount of water for optimal cleaning. See "What's New under the Lid." IMPORTANT: Do not add more water to washer. The added water lifts the load off the impeller, resulting in less cleaning.

TROUBLESHOOTING (continued)

⚠ **WARNING**



Electrical Shock Hazard

Plug into a grounded 3 prong outlet.
 Do not remove ground prong.
 Do not use an adapter.
 Do not use an extension cord.
 Failure to follow these instructions can result in death, fire, or electrical shock.

First try the solutions suggested here or visit our website at www.whirlpool.com/help for assistance and to possibly avoid a service call.

If you experience	Possible Causes	Solution
Washer not performing as expected (cont.)		
Washer won't run or fill, washer stops working	Check for proper water supply.	Both hoses must be attached and have water flowing to inlet valve.
		Both Hot and Cold water faucets must be turned on.
		Check that inlet valve screens have not become clogged.
		Check for any kinks in inlet hoses, which can restrict water flow.
	Check proper electrical supply.	Plug power cord into a grounded 3 prong outlet.
		Do not use an extension cord.
		Ensure there is power to outlet.
		Reset a tripped circuit breaker. Replace any blown fuses. NOTE: If problems continue, contact an electrician.
	Normal washer operation.	Lid must be closed for washer to run.
		Washer will pause during certain phases of cycle. Do not interrupt cycle.
		Washer may be stopped to reduce suds.
		Washer spins the load before filling to determine load size.
	Washer may be overloaded.	Remove several items, rearrange load evenly in basket and add detergent. Close lid and press START/PAUSE.
		Do not add more than 1 or 2 additional items after cycle has started to avoid overloading or unbalancing.
		Do not add more water to the washer.
	Not using HE detergent.	Only use HE detergent. Suds from regular detergents can slow or stop the washer. Always measure detergent and following detergent directions based on your load requirements.
To remove suds, cancel cycle. Select DRAIN & SPIN. Select your cycle. Press START. Do not add more detergent.		

TROUBLESHOOTING (continued)

<p>Washer not draining/ spinning, loads are still wet</p>	<p>Empty pockets and use garment bags for small items.</p>	<p>Small items may have been caught in pump or between basket and tub, which can slow draining.</p>
	<p>Use a cycle with a high spin speed.</p>	<p>Cycles with lower spin speeds remove less water than cycles with high spin speeds. Use the recommended cycle/speed spin for your garment.</p>
	<p>The washer may be overloaded</p>	<p>Overloading or unbalanced loads will not allow the washer to spin correctly, leaving the load wetter than normal. See "Using Your Washer" for loading recommendations.</p>
	<p>Check plumbing for correct drain hose installation. Drain hose extends into standpipe farther than 4.5" (114 mm).</p>	<p>Check drain hose for proper installation. Use drain hose form and securely attach to drainpipe or tub. Do not tape over drain opening. Lower drain hose if the end is higher than 96" (2.4 m) above the floor. Remove any clogs from drain hose.</p>
	<p>Wrong or too much detergent causing suds to slow or stop draining and spinning?</p>	<p>Use only HE detergent. Always measure and follow detergent directions for your load. To remove extra suds, Select DRAIN & SPIN and desired cycle. Do not add detergent.</p>

TROUBLESHOOTING (continued)

First try the solutions suggested here or visit our website at www.whirlpool.com/help for assistance and to possibly avoid a service call.

If you experience	Possible Causes	Solution
Washer not performing as expected (cont.)		
Not cleaning or removing stains (cont.)	Not using HE detergent.	The suds from regular detergent can prevent washer from operating correctly.
		Use only HE detergent.
		Always measure detergent and follow manufacture's directions based on load size and soil level.
	Not using correct cycle for fabric type.	Use a higher soil level cycle option and warmer wash temperature to improve cleaning.
		If using Quick Wash cycle, wash only a few items.
		Use Whites and Heavy Duty cycle for tough cleaning.
	Not using dispensers.	Use dispensers to avoid chlorine bleach and fabric softener staining.
		Load dispensers before starting a cycle.
		Avoid overfilling.
		Do not add products directly to load.
	Not washing like colors together.	Wash like colors together and remove promptly after the cycle is complete to avoid dye transfer.
	Odors	Monthly maintenance not done as recommended.
Unload washer as soon as cycle is complete.		
Using wrong or too much detergent.		Use only HE detergent.
		Always follow the manufacturer's directions.
		See "Cleaning your Washer" section.
Fabric Damage	Sharp items were in pockets during wash cycle.	Empty pockets, zip zippers, and snap or hook fasteners before washing to avoid snags and tears.
	Strings and straps could have tangled.	Tie all strings and straps before starting wash load.
	Items may have been damaged before washing.	Mend rips and broken threads in seams before washing.
	Fabric damage can occur if washer is overloaded.	Load garments in loose heaps evenly around the basket wall.
		Do not load above the stainless steel portion of the basket. Load with dry items only.
		Use cycle designed for the fabrics being washed.
		Add only 1 or 2 garments after washer is started.
	Liquid chlorine bleach may have been added incorrectly.	Do not pour liquid chlorine bleach directly onto load. Wipe up bleach spills.
		Undiluted bleach will damage fabrics. Do not use more than recommended by manufacturer.
		Do not place load items on top of bleach dispenser when loading and unloading washer.
Garment care instructions may not have been followed.	Always read and follow garment manufacturer's care label instructions.	

TROUBLESHOOTING (continued)

First try the solutions suggested here or visit our website at www.whirlpool.com/help for assistance and to possibly avoid a service call.

If you experience	Possible causes	Solution
Washer not performing as expected (cont.)		
Incorrect or wrong wash or rinse temperatures	Check for proper water supply.	Are hot and cold inlet hoses reversed?
		Both hoses must be attached to both washer and faucet, and have both hot and cold water flowing to inlet valve.
Check that inlet valve screens are not clogged.		
Remove any kinks in hoses.		
	Energy saving controlled wash temperatures.	Energy Star washers use cooler wash and rinse water temperatures than your previous washer. This includes cooler hot and warm washes.
Load not rinsed	Check for proper water supply.	Are hot and cold inlet hoses reversed?
		Both hoses must be attached and have water flowing to the inlet valve.
		Both hot and cold water faucets must be on.
		Inlet valve screens on washer maybe clogged.
		Remove any kinks in the inlet hose.
	Not using HE detergent.	The suds from regular detergent can prevent washer from operating correctly.
		Use only HE detergent.
		Always measure detergent and follow detergent directions based on load size and soil level.
	Washer not loaded as recommended.	The washer is less efficient at rinsing when overloaded.
		Load garments in loose heaps evenly around the basket wall.
		Do not load above the stainless steel portion of the basket. The washer will not rinse well if overloaded. Load with dry items only.
		Use cycle designed for the fabrics being washed.
		Add only 1 or 2 garments after washer has started.
Load is tangling	Washer not loaded as recommended.	See "Using Your Washer" section.
		Select a cycle with a slower wash action and spin speed, however items will be wetter than those using a higher speed spin.
		Load garments in loose heaps evenly around the basket wall. Do not load above the stainless steel portion of the basket.
		Reduce tangling by mixing types of load items. Use the recommended cycle for the type of garments being washed.
Not cleaning or removing stains	Wash load not completely covered in water.	Washer senses load size and adds correct amount of water. This is normal and necessary for clothes to move.
	Added more water to washer.	Added water lifts the laundry off the impeller, resulting in less effective cleaning.
	Washer not loaded properly.	Washer is less efficient at cleaning when overloaded.
		Load garments in loose heaps evenly around the basket wall.
		Do not load above the stainless steel portion of basket. Load with dry items only.
	Add only 1 or 2 garments after washer has started.	

TROUBLESHOOTING (continued)

First try the solutions suggested here or visit our website at www.whirlpool.com/help for assistance and to possibly avoid a service call.

If you experience	Possible Causes	Solution
Washer not performing as expected (cont.)		
Incorrect dispenser operation	Clogged dispensers or laundry products dispensing too soon.	Do not overfill dispenser, which causes immediate dispensing.
		Always select Fabric Softener option to assure proper dispensing.
		Load dispensers before starting a cycle.
		It is normal for small amounts of water to be remain in dispenser.
		Homes with low water pressure may result in residual powder in the dispenser. To avoid, select a warmer wash temperature if possible, depending on your load.
		Use only liquid chlorine bleach in the bleach dispenser.
No sound when buttons are pressed	Button sounds are turned off.	Button sounds can be turned on or off by pressing and holding Cycle Signal for 5 seconds.

COMPONENT ACCESS

This section instructs you on how to service each component inside the 2010 Vertical Modular Washer. The components and their locations are shown.

⚠ WARNING



Electrical Shock Hazard
Disconnect power before servicing.
Replace all parts and panels before operating.
Failure to do so can result in death or electrical shock.

Unplug washer or disconnect power.

COMPONENT LOCATIONS

Front of washer

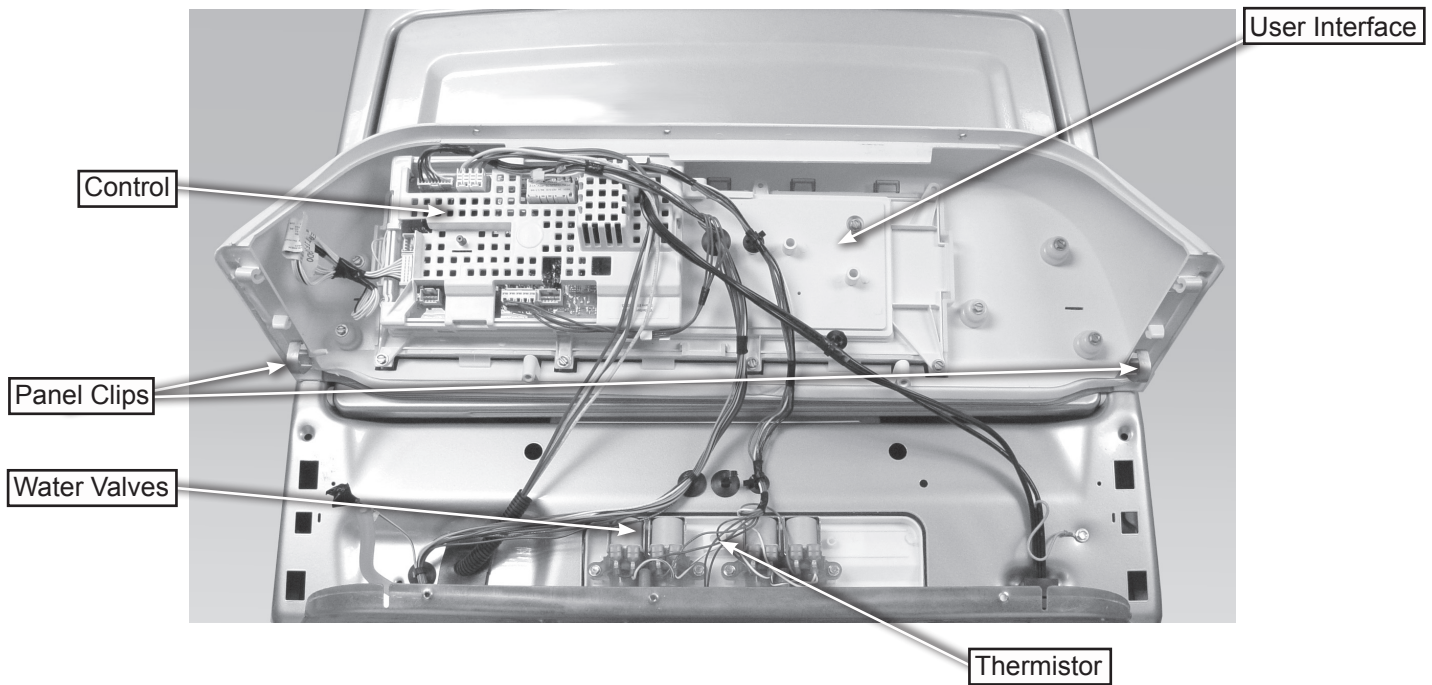

COMPONENT LOCATIONS (continued)

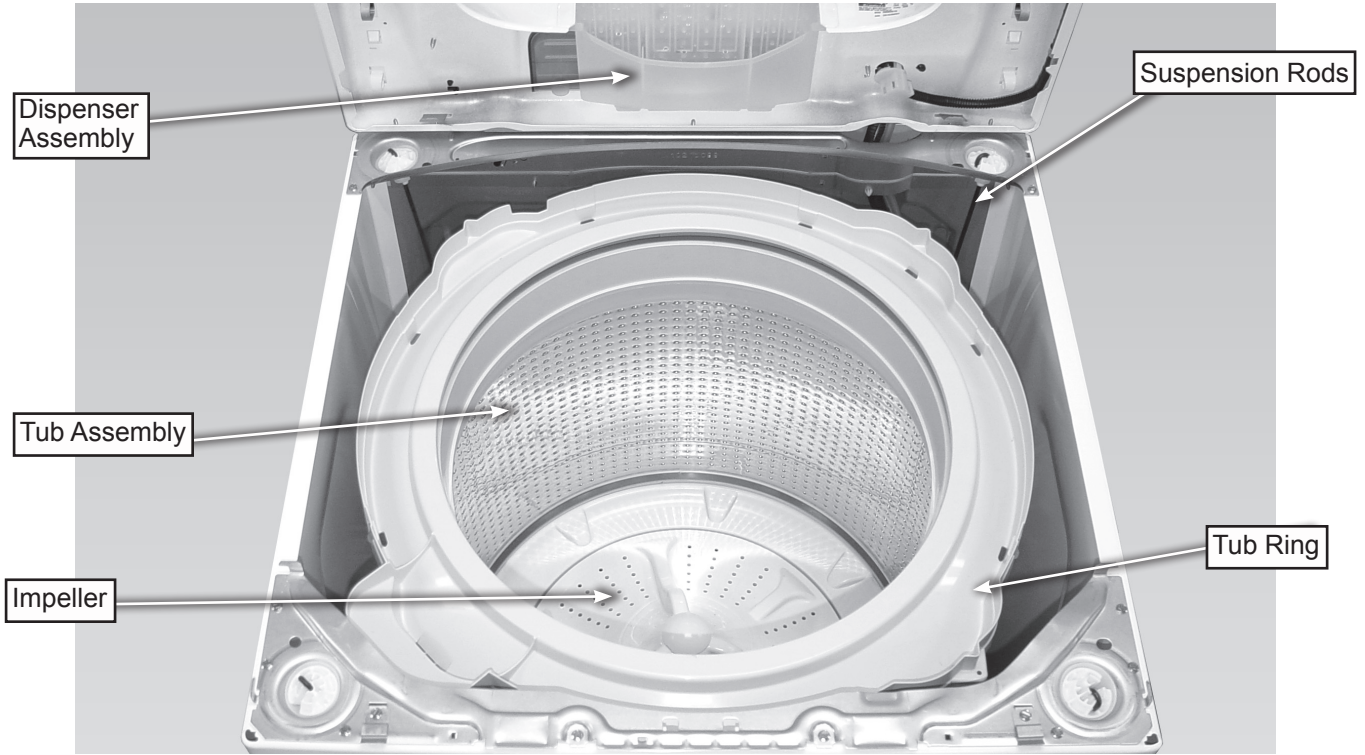

View from the front (with the top lifted)

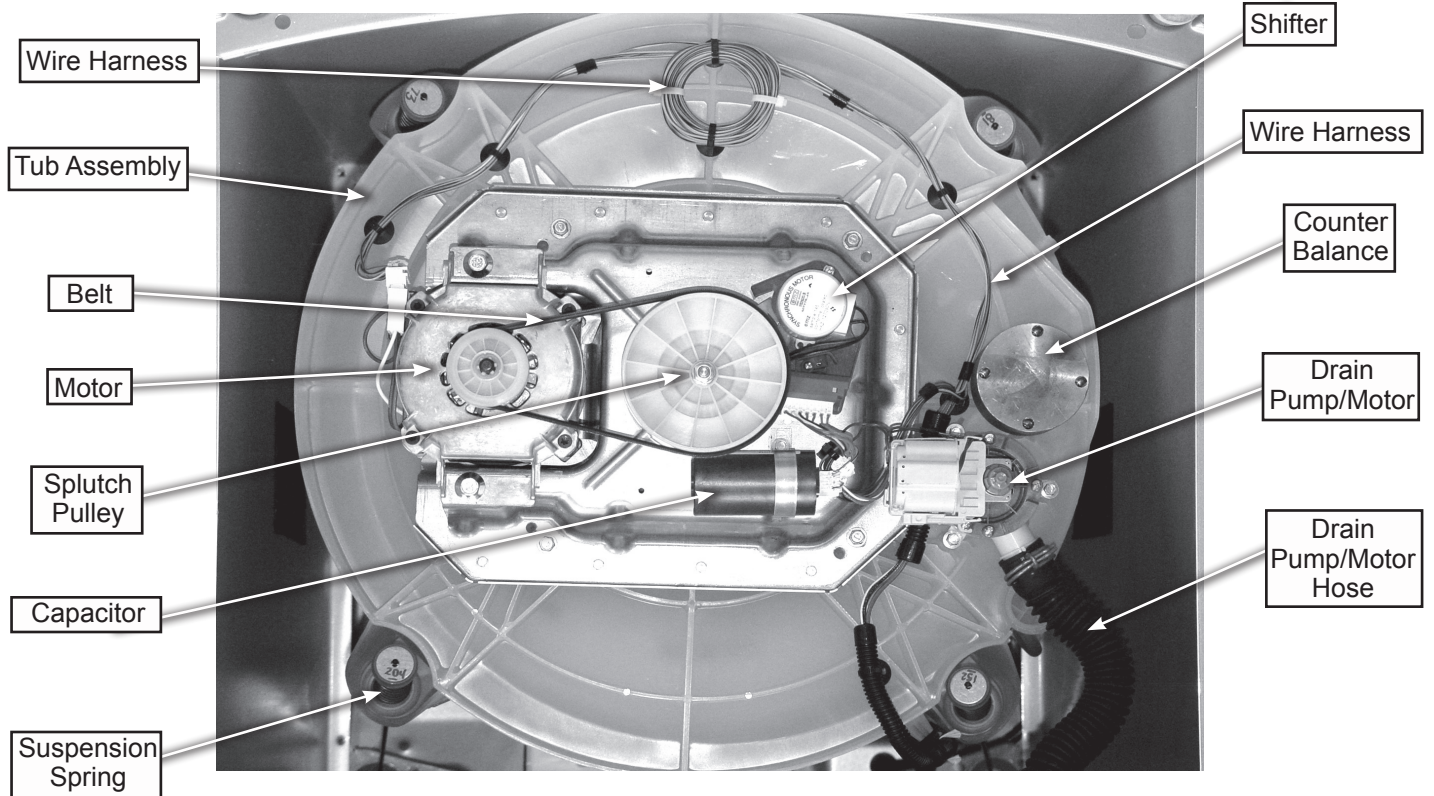

View from the bottom with the washer on it's back (with pulley cover removed)

REMOVING THE CONTROL PANEL

Access to the water inlet valves, control and user interface is from inside of the control panel.

⚠ WARNING



Electrical Shock Hazard

Disconnect power before servicing.

Replace all parts and panels before operating.

Failure to do so can result in death or electrical shock.

1. Unplug washer or disconnect power.
2. Turn off the water supply to the washer.
3. Remove only the (2) top screws from the control panel's rear panel, see figure 1.



Figure 1

4. Push back on the control panel just enough to slide a putty knife under the right or left corner of the control panel. Lift the corner of the panel and push in with the putty knife blade to release the clip. Repeat the procedure for the other clip, see figures 2 and 3.



Figure 2



Figure 3

5. Lift the panel off of the top, see figure 4.

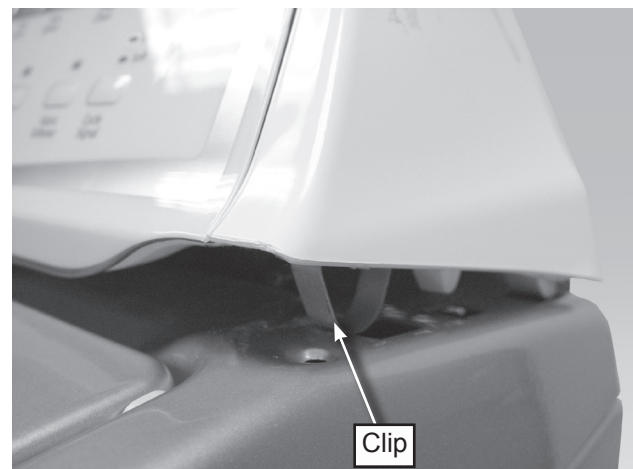

Figure 4

REMOVING THE CONTROL

⚠ WARNING



Electrical Shock Hazard

Disconnect power before servicing.

Replace all parts and panels before operating.

Failure to do so can result in death or electrical shock.

1. Unplug washer or disconnect power.
2. Turn off the water supply to the washer.
3. Remove the control panel. See the section: "REMOVING THE CONTROL PANEL".
4. Remove harness from control, see figure 1.
 - a. Pull tabs back for J-2 removal.
 - b. Pull tabs back for J-12 removal.
 - c. Remove two wire connector at J-7.
 - d. Wires for J-3 are routed and tucked under the braces and are held in place by a tree clip. Remove the connector by pinching the tabs on the sides of the connector.
 - e. J-15 and J-16 are "pinch" connectors and the wires are held by a tree clip.
5. Remove the knob by grasping it and pulling it toward you, see figure 2.
6. Remove one (1) screw and release two (2) locking tabs on the User Interface to replace control, see figure 3.

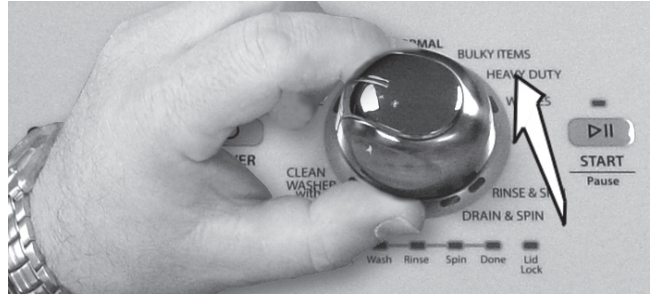

Figure 2

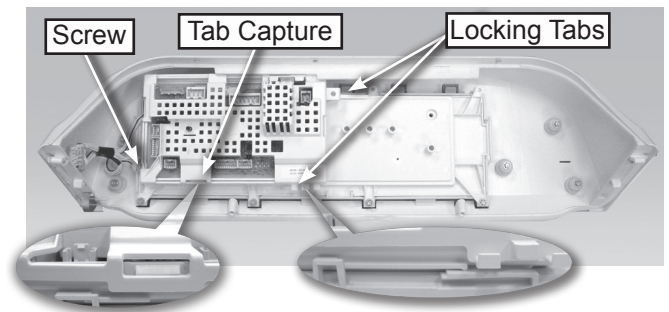

Figure 3

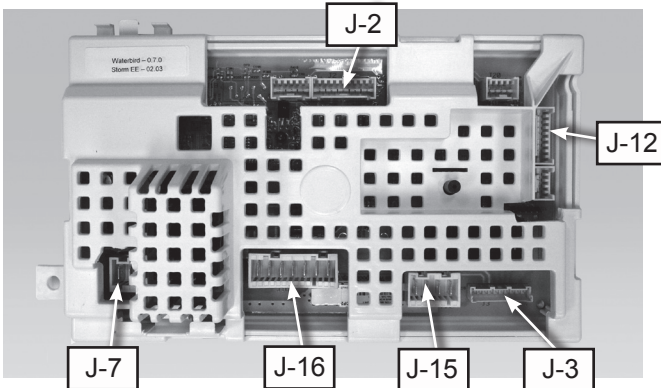

Figure 1

USER INTERFACE REMOVAL AND INSTALLATION PROCEDURE

⚠ WARNING



Electrical Shock Hazard

Disconnect power before servicing.
Replace all parts and panels before operating.

Failure to do so can result in death or electrical shock.

IMPORTANT

Electrostatic Discharge (ESD) Sensitive Electronics

ESD problems are present everywhere. ESD may damage or weaken the machine control electronics. The new control assembly may appear to work well after repair is finished, but failure may occur at a later date due to ESD stress.

- Use an anti-static wrist strap. Connect wrist strap to green ground connection point or unpainted metal in the appliance
-OR

Touch your finger repeatedly to a green ground connection point or unpainted metal in the appliance.

- Before removing the part from its package, touch the anti-static bag to a green ground connection point or unpainted metal in the appliance.
- Avoid touching electronic parts or terminal contacts; handle machine control electronics by edges only.
- When repackaging failed machine control electronics in anti-static bag, observe above instructions.

1. Unplug washer or disconnect power.

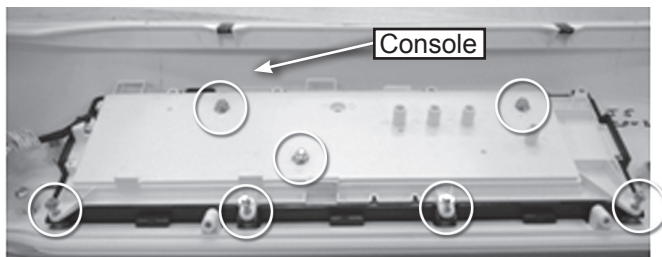

Figure 1

2. Remove the seven (7) screws circled in Figure 1 that secure the user interface to the console.

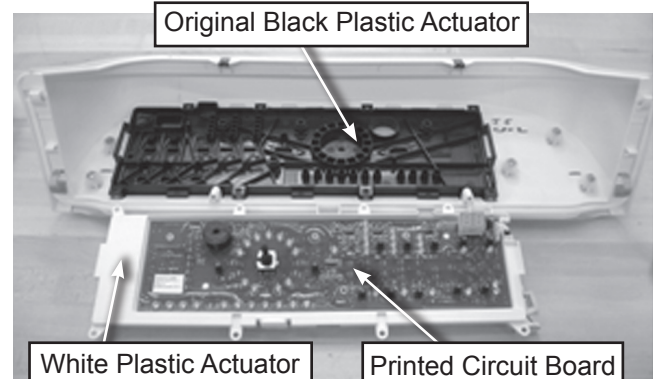

Figure 2

3. Remove white plastic cover and printed circuit board.

IMPORTANT: Leave the original black plastic actuator attached to the console. See figure 2.

4. Remove new black plastic actuator from the service assembly in the kit. Install the new user interface onto the original black plastic actuator mounted in console. Discard the new black plastic actuator. See Figure 3.

IMPORTANT: Hand assemble the seven (7) screws to avoid stripping the threads in the plastic components. Do not use electric screwdriver.

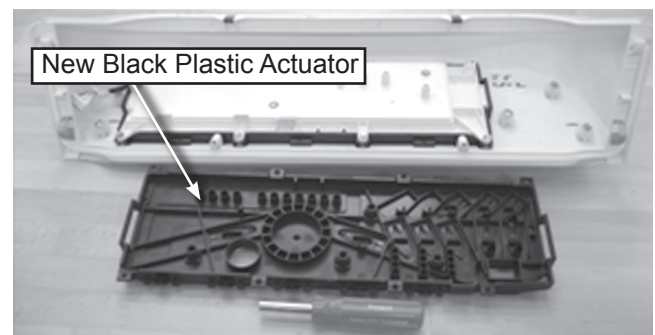

Figure 3

5. Replace all parts and panels.
6. Plug in washer or reconnect power.

REMOVING THE TOP

Access to the detergent dispenser and lid switch/latch assembly is from under the top. The top is held on with by channel connections at the front and two screws at the rear.

⚠ WARNING



Electrical Shock Hazard

Disconnect power before servicing.

Replace all parts and panels before operating.

Failure to do so can result in death or electrical shock.

1. Unplug washer or disconnect power.
2. a. Turn off the water supply to the washer.
b. Tape the lid down.
3. a. Remove top screw from each hinge (2), see figure 1.
b. Remove wire harness cover.
4. Slide top forward about $\frac{1}{2}$ ",

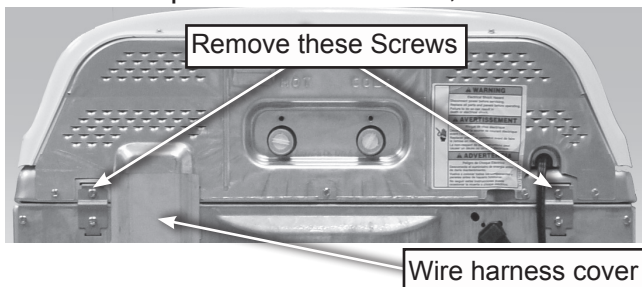

Figure 1

see figure 2.

5. Raise the top about $\frac{1}{4}$ ".

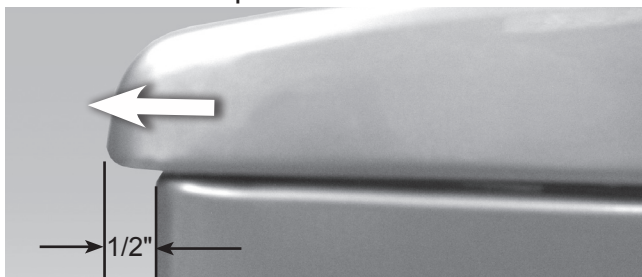

Figure 2

6. While still keeping it lifted, push the top back about $\frac{1}{4}$ ", see figure 3.
7. Tilt the top up on the rear hinges,

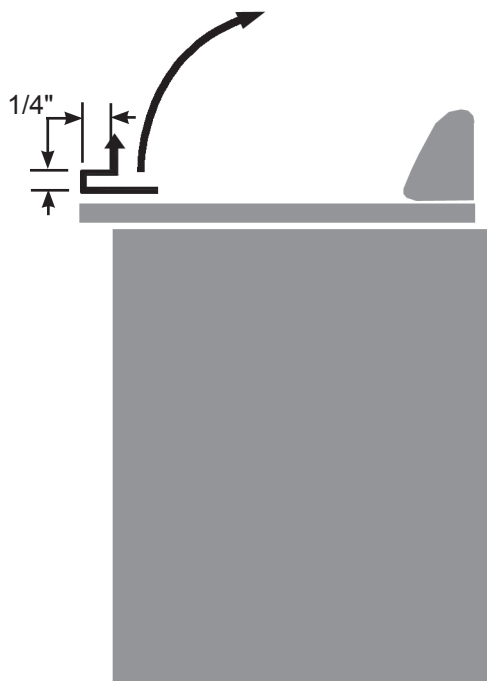

Figure 3

see figure 4.



Figure 4

REMOVING THE WATER INLET VALVE

The water valves are located under the control panel.

⚠ WARNING

Electrical Shock Hazard Disconnect power before servicing. Replace all parts and panels before operating. Failure to do so can result in death or electrical shock.

1. Unplug washer or disconnect power.
2. Purge the water pressure from the hoses by setting the washer to fill on WARM.
3. Remove the control panel. See the section: "REMOVING THE CONTROL PANEL".
4. Lift the panel off of the top.
5. Remove the hoses. Use a towel to catch any water drippings.
6. Unplug the harness from the valve coils.
7. Unscrew two (2) mounting screws on each valve coil set, see figure 1.
8. Lift valve off of dispenser.

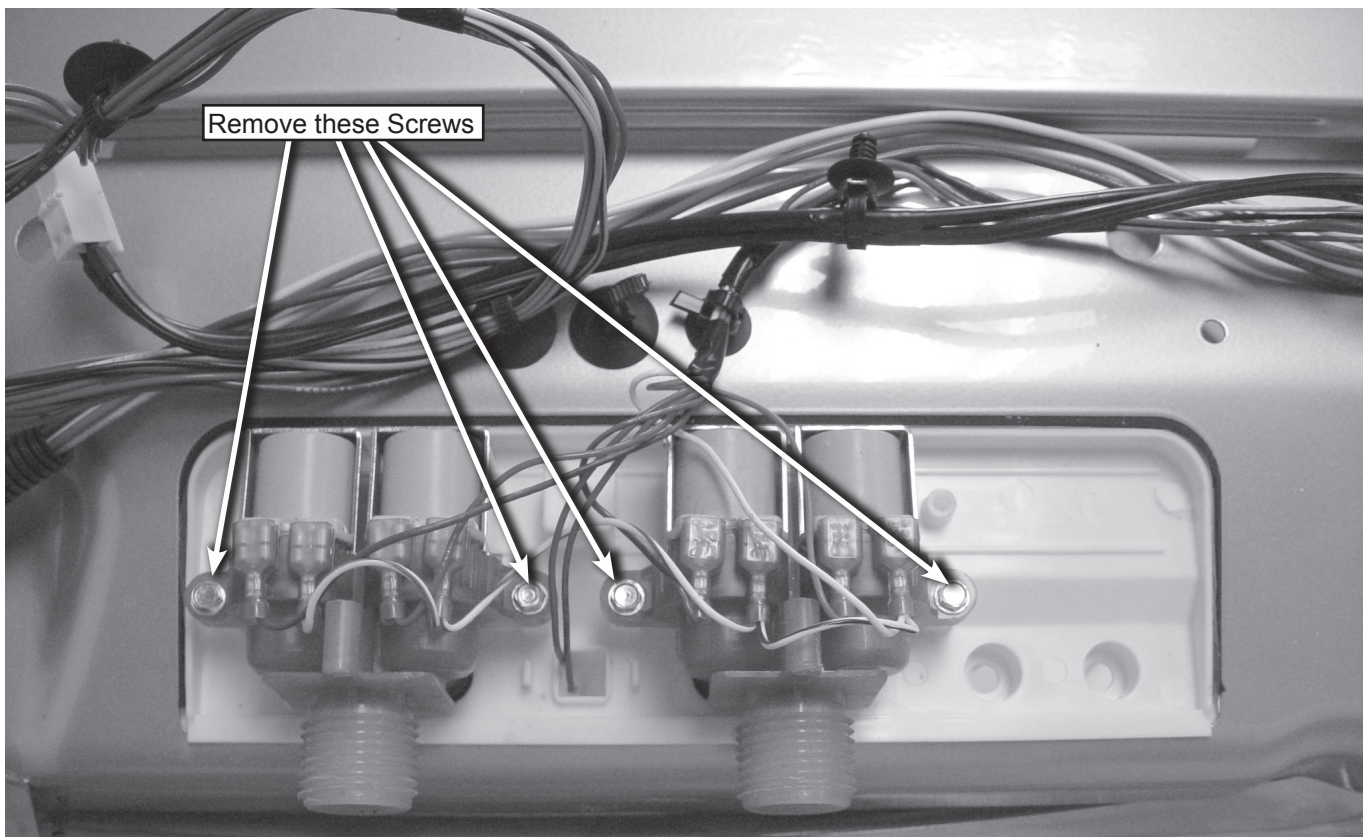

Figure 1

REMOVING THE DETERGENT DISPENSER ASSEMBLY

The detergent dispenser assembly fits into the top.

⚠ WARNING



Electrical Shock Hazard

**Disconnect power before servicing.
Replace all parts and panels before
operating.**

**Failure to do so can result in death or
electrical shock.**

1. Unplug washer or disconnect power.
2. Turn off the water supply to the washer.
3. Remove the water inlet valves, see figure 1 and the section: "REMOVING THE WATER INLET VALVE".

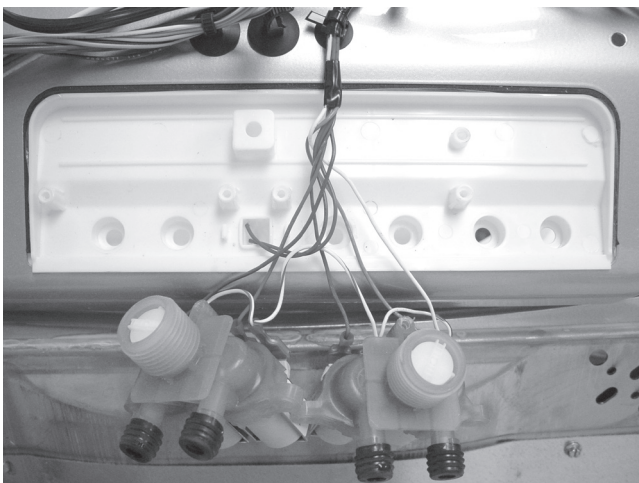

Figure 1

4. Raise the top on the hinges, see figure 2 and the section: "REMOVING THE TOP".

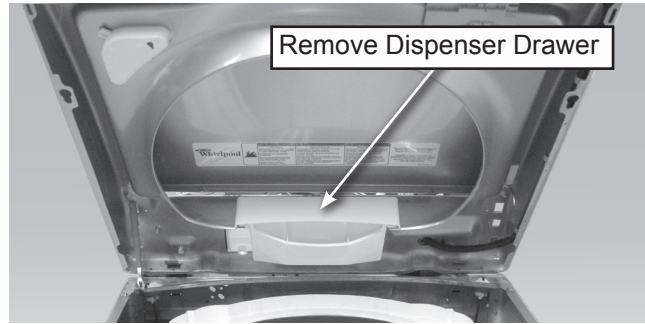

Figure 2

5. Remove the dispenser drawer, see figure 2.
6. Remove the (2) screws securing the dispenser to the front trim, see figure 3.



Figure 3



Figure 4

7. Remove the trim, see figure 4.
8. The dispenser is held in the back by tabs, see figure 5.

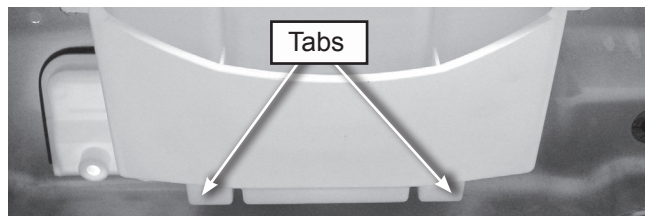

Figure 5

REMOVING THE LID SWITCH/LOCK ASSEMBLY

The lid switch/lock assembly is located under the top on the front right-hand side.

! WARNING



Electrical Shock Hazard
Disconnect power before servicing.
Replace all parts and panels before operating.
Failure to do so can result in death or electrical shock.

1. Unplug washer or disconnect power.
2. Turn off the water supply to the washer.
3. Remove the control panels' rear panel.
4. Raise the top on the hinges, see figure 1 and the section: "REMOVING THE TOP".

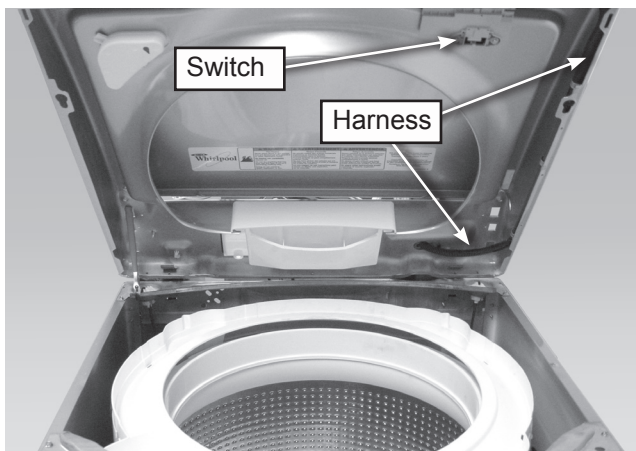

Figure 1

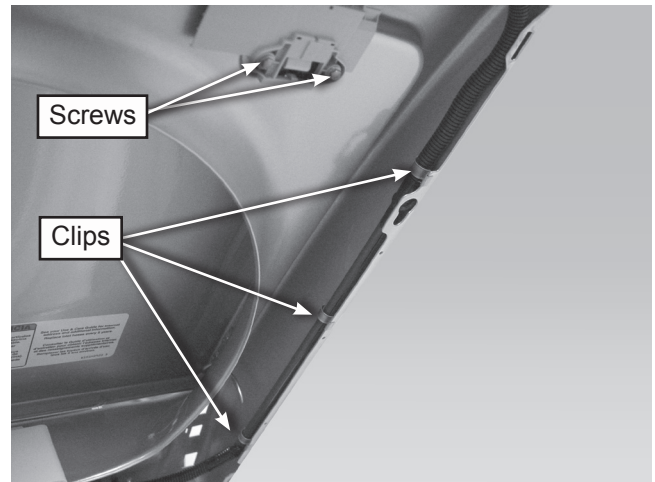
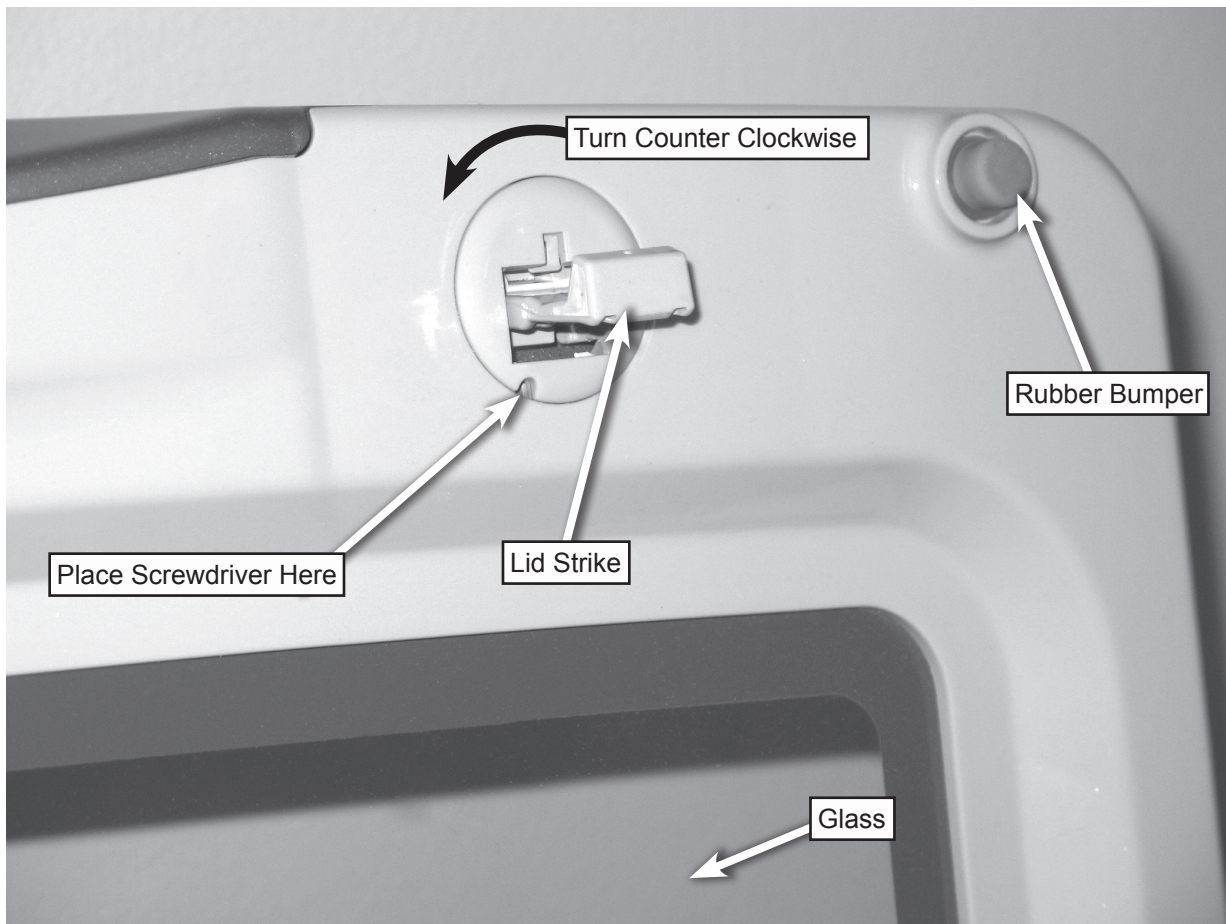

Figure 2

5. Remove the two (2) mounting screws securing the switch to the top, see figure 2.
6. Remove the switch.
7. Unclip the harness from the top, see figure 2.
8. Unplug the harness from the control.

REMOVING THE LID STRIKE ON GLASS LID MODELS

1. Push a small screwdriver into the hole of the lid strike to release a locking tab.
2. Turn the strike counter clockwise.
3. Pull the strike out of the mounting hole.



View of upper right corner of underside of the glass top.

REMOVING THE SHIFTER

⚠ WARNING



Electrical Shock Hazard

Disconnect power before servicing.

Replace all parts and panels before operating.

Failure to do so can result in death or electrical shock.

1. Unplug washer or disconnect power.

⚠ WARNING

Excessive Weight Hazard

Use two or more people to move and install washer.

Failure to do so can result in back or other injury.

2. Turn off the water supply to the washer
3. Use cardboard or padding to lay washer on the front cabinet..
4. Disconnect hoses
5. Remove the harness from the shifter, see figure 1.
6. Remove the two mounting screws, see figure 1.
7. Lift out.

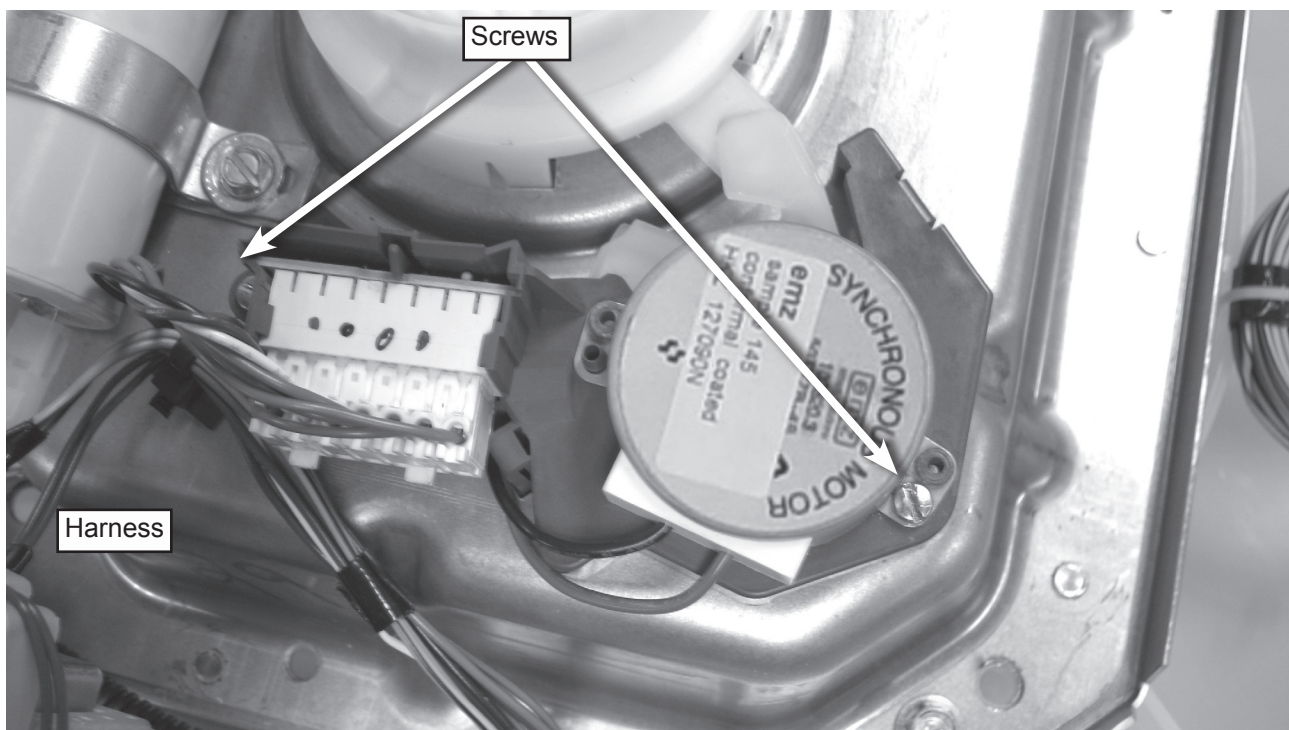

Figure 1

REMOVING THE DRAIN PUMP

Access to the drain pump is from the bottom of the unit. The drain pump seals against the tub at two points (see the image on the right).

! WARNING



Electrical Shock Hazard

Disconnect power before servicing.

Replace all parts and panels before operating.

Failure to do so can result in death or electrical shock.

1. Unplug washer or disconnect power.

! WARNING

Excessive Weight Hazard

Use two or more people to move and install washer.

Failure to do so can result in back or other injury.

2. Turn off the water supply to the washer

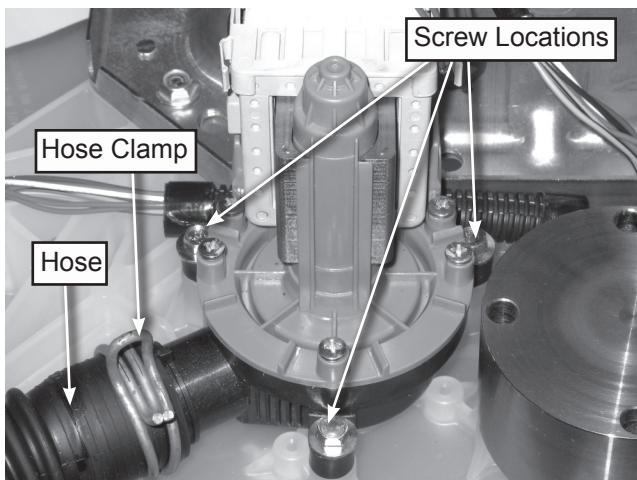

Figure 1

3. Use cardboard or padding to lay washer on the front cabinet.
4. Disconnect hoses
5. Remove the harness from the pump motor.
6. Remove hose clamp and hose, see figure 1.
7. Remove three (3) mounting screws, see figure 2.
8. Remove pump assembly, see figure 2.

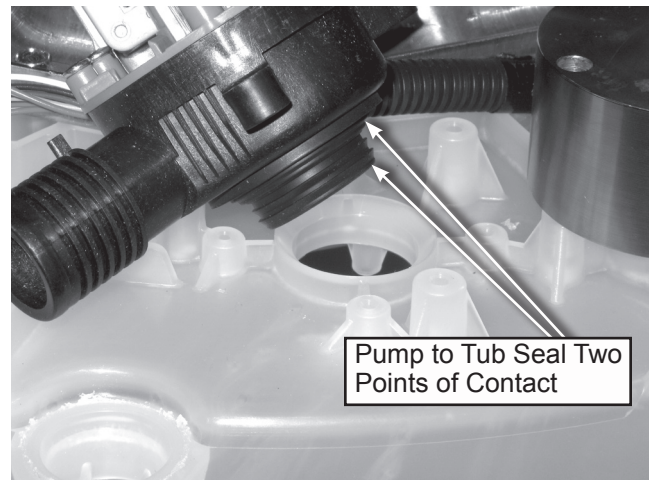

Figure 2

REMOVING THE DRIVE BELT AND MOTOR

⚠ WARNING



Electrical Shock Hazard

**Disconnect power before servicing.
Replace all parts and panels before
operating.**

**Failure to do so can result in death or
electrical shock.**

1. Unplug washer or disconnect power.

⚠ WARNING

Excessive Weight Hazard

**Use two or more people to move and
install washer.**

**Failure to do so can result in back or
other injury.**

2. Turn off the water supply to the washer.
3. Use cardboard or padding to lay washer on the front cabinet.
4. Disconnect hoses.
5. Remove pulley cover.
6. To remove the belt, pull out on the belt and turn the splutch pulley until the belt slides off.
7. To remove the motor, unplug the harness and remove the two (2) mounting bolts, see figure 1.

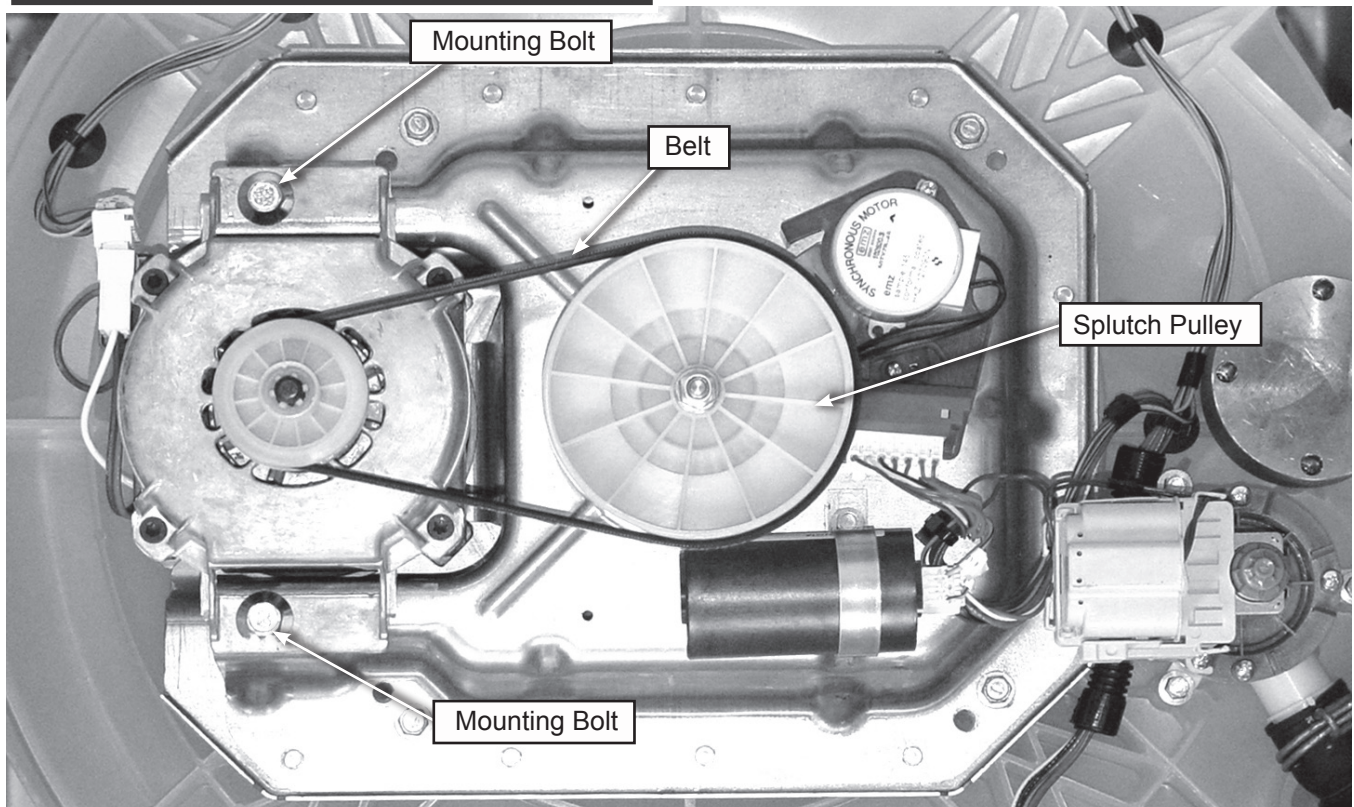

Figure 1

REMOVING THE SPLUTCH

⚠ WARNING



Electrical Shock Hazard

Disconnect power before servicing.

Replace all parts and panels before operating.

Failure to do so can result in death or electrical shock.

1. Unplug washer or disconnect power.

⚠ WARNING

Excessive Weight Hazard

Use two or more people to move and install washer.

Failure to do so can result in back or other injury.

2. Turn off the water supply to the washer.

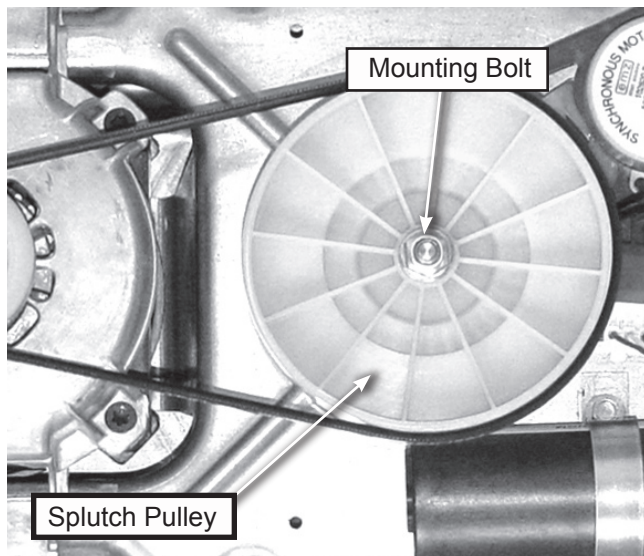

Figure 1

3. Remove the belt. See the section: "REMOVING THE DRIVE BELT AND MOTOR".
4. Hold the splutch pulley and remove the mounting bolt, see figure 1.
5. Lift off the pulley.
6. Remove the shifter. See the section: "RE-

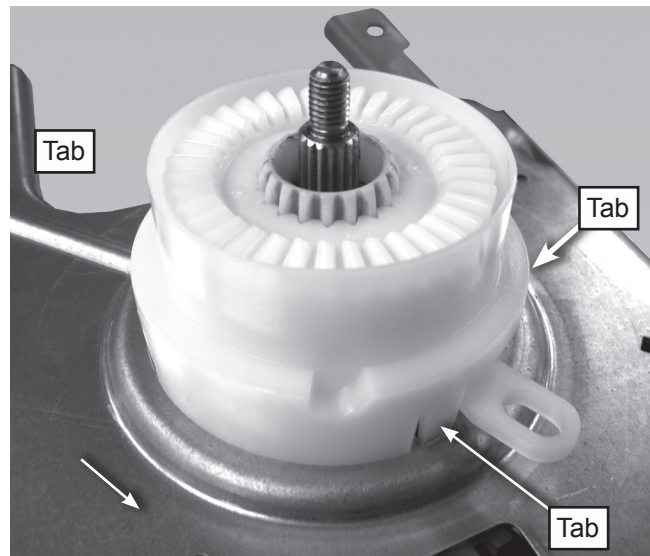

Figure 2

REMOVING THE GEARCASE

WARNING



Electrical Shock Hazard

Disconnect power before servicing.

Replace all parts and panels before operating.

Failure to do so can result in death or electrical shock.

1. Unplug washer or disconnect power.

WARNING

Excessive Weight Hazard

Use two or more people to move and install washer.

Failure to do so can result in back or other injury.

2. Turn off the water supply to the washer.

3. Remove the impeller. See the section "REMOVING THE IMPELLER AND BASKET".

4. Remove impeller bolt.

5. Remove the basket. See the section "REMOVING THE IMPELLER AND BASKET".

6. Use cardboard or padding to lay washer on the front cabinet.

7. Disconnect hoses.

8. Remove the belt. See the section: "REMOVING THE DRIVE BELT AND MOTOR".

9. Remove the motor. See the section: "REMOVING THE DRIVE BELT AND MOTOR".

10. Remove the splutch assembly. See the section: "REMOVING THE SPLUTCH".

11. Remove the shifter. See the section: "REMOVING THE SHIFTER".

12. Remove the capacitor.

13. Remove the drain pump. See the section: "REMOVING THE DRAIN PUMP".

14. Remove the four (4) mounting bolts.

15. Pull the gearcase out of the tub.

REMOVING THE GEARCASE (continued)



As an alternative to the previous steps, the belt, motor, splutch, shifter and capacitor may also be removed along with the gearcase as outlined below:.

1. Unplug washer or disconnect power.
2. Turn off the water supply to the washer.
3. Remove the basket. See the section removing the impeller and basket.
4. Use cardboard or padding to lay washer on the front cabinet.
5. Unplug the harness from the motor, shifter and capacitor.
6. Remove the four mounting bolts and pull the gearcase out of the tub.

NOTE: The tub and gearcase has 8 mounting holes. Only 4 are used. If they strip out during reassembly, the other holes can be used to re-mount the gearcase.

REMOVING THE TUB RING

⚠ WARNING

Electrical Shock Hazard Disconnect power before servicing. Replace all parts and panels before operating. Failure to do so can result in death or electrical shock.

1. Unplug washer or disconnect power
2. Raise the top on the hinges. See the section: "REMOVING THE TOP".
3. To release the tub ring from the tub; first, press press back and down on the top of the tub ring to reduce pressure on the keyed locking tab, then release the tab, see figure 1.

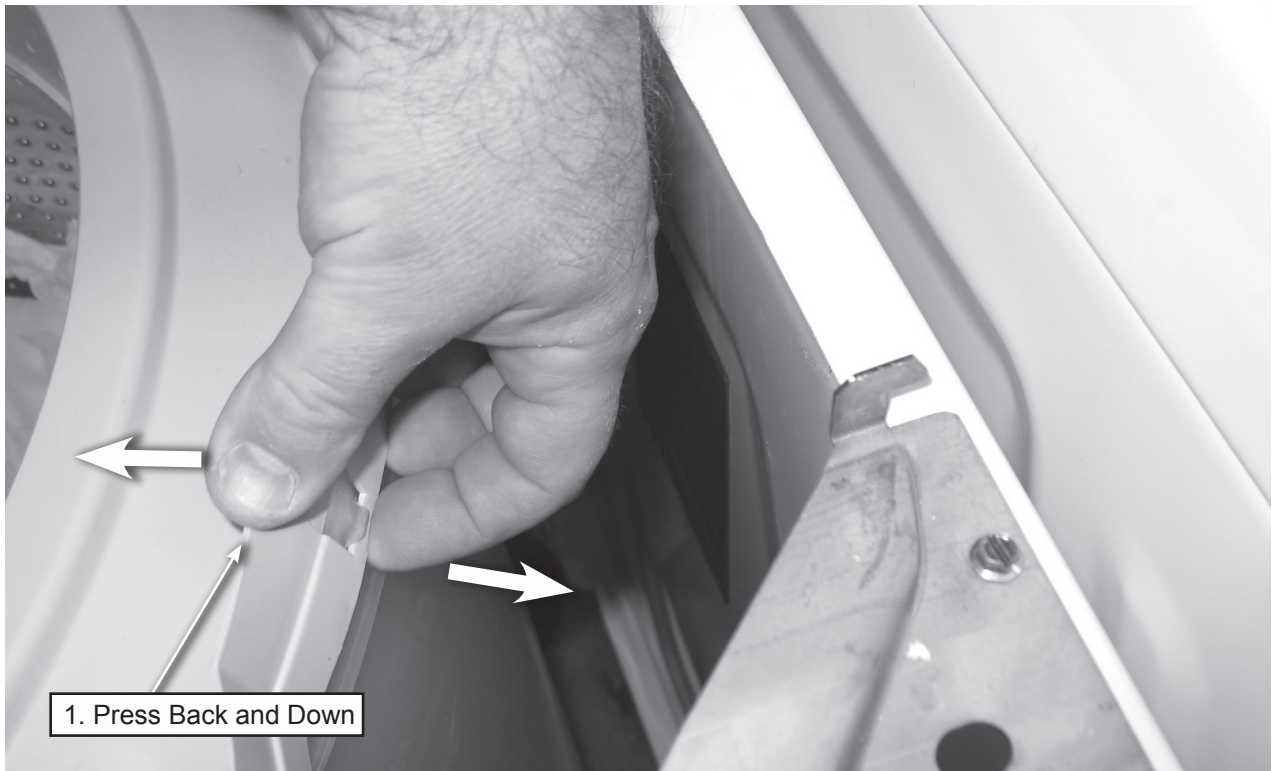

Figure 1

REMOVING THE IMPELLER AND BASKET

⚠ WARNING



Electrical Shock Hazard

Disconnect power before servicing.

Replace all parts and panels before operating.

Failure to do so can result in death or electrical shock.

1. Unplug washer or disconnect power.

⚠ WARNING

Excessive Weight Hazard

Use two or more people to move and install washer.

Failure to do so can result in back or other injury.

2. Turn off the water supply to the washer.
3. Raise the top on the hinges. See the section: "REMOVING THE TOP".
4. Remove harness from control and water valves to set the top aside.

5. Remove tub ring.
6. Remove impeller bolt cover, see figure 1.
7. Remove impeller bolt.
8. Remove impeller.
9. Remove impeller.

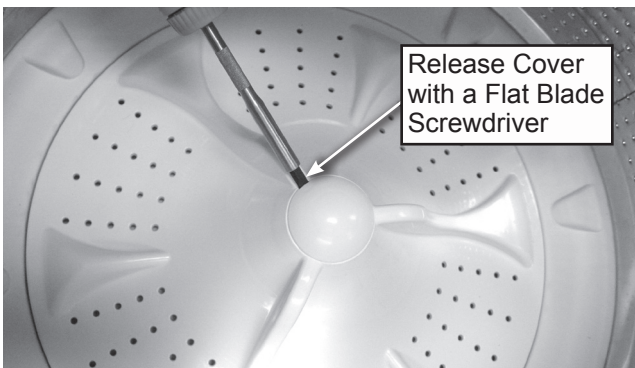

Figure 1

BASKET DRIVE BLOCK REMOVAL AND INSTALLATION PROCEDURE

⚠ WARNING



Electrical Shock Hazard

Disconnect power before servicing.
Replace all parts and panels before operating.

Failure to do so can result in death or electrical shock.

1. Unplug washer or disconnect power.

NOTE: Always install a new drive block, driven hub and spanner nut if the basket, drive assembly or drive block are removed for service. See figure 1.

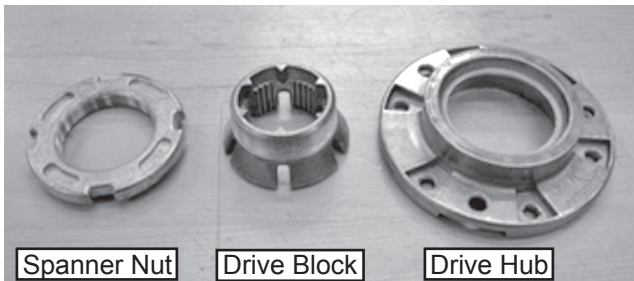

Figure 1

2. Remove impeller. Remove cap covering impeller bolt, with a flat blade screwdriver. Remove impeller bolt, pull up on impeller to remove. See Figure 2.

NOTE: Using rubber palmed gloves to grip impeller and lifting straight up aids in removal of impeller.

3. Use a spanner wrench and hammer to remove the spanner nut. See figure 3.

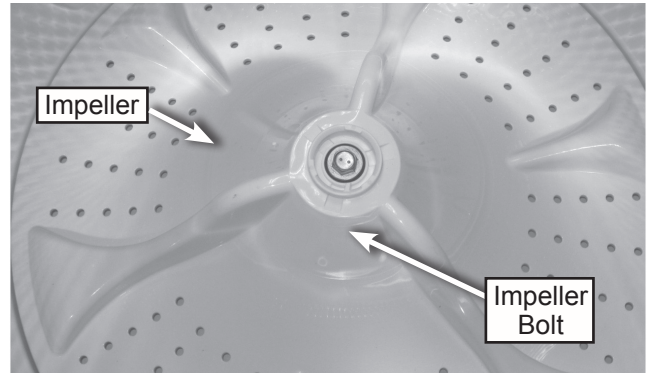

Figure 2

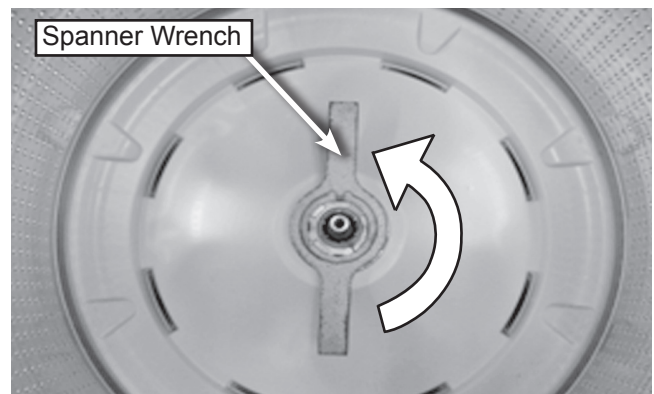

Figure 3

4. Remove six (6) screws from basket driven hub. **IMPORTANT:** Remove the screws slowly if using a powered screwdriver. Hold up on basket while removing the last two (2) screws to avoid stripping out threads. See figure 4.

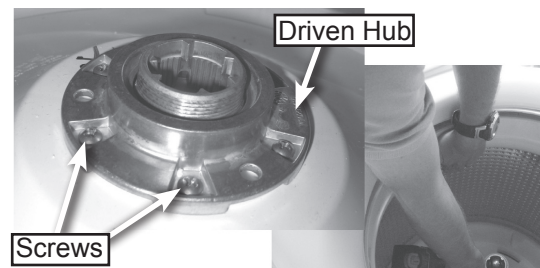

Figure 4

5. Remove driven hub and drive block. **NOTE:** When driven hub is removed, basket will drop slightly. Basket and drive assembly can be replaced at this time if needed. Follow all Instructions that may come with the new basket or drive assembly.

BASKET DRIVE BLOCK REMOVAL AND INSTALLATION PROCEDURE (continued)

6. Install new drive block onto spin tube. The drive block should be fully seated on the spin tube with the stops resting on the top of the spin tube. See Figure 5.

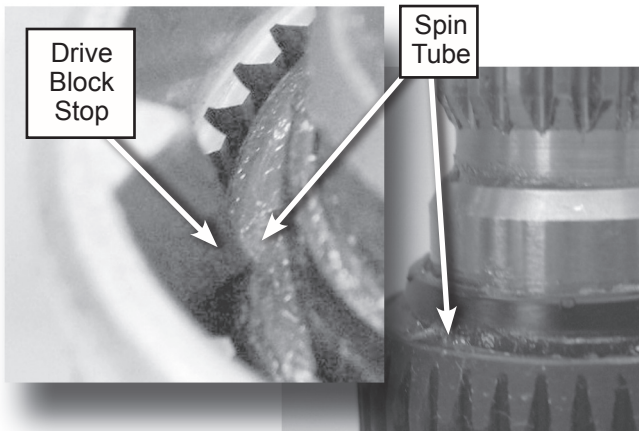

Figure 5

7. Install the new driven hub using new screws supplied in kit, screw in only half way initially.

IMPORTANT: If using power screwdriver set on low speed and low torque. Do not strip threads in the plastic base.

8. Lift the basket up with 2 hands as shown in Figure 6 to reduce the gap between the basket and driven hub, then use one hand to hold basket up while driving in two (2) screws that are on opposite sides of the new driven hub. Fully seat the remaining screws.

NOTE: Failure to lift basket prior to tightening screws will result in stripped threads.



Figure 6

9. Install spanner nut. Hand tighten spanner nut without tools, until fully seated. See Figure 7.



Figure 7

10. Place spanner wrench on spanner nut. Mark starting location of spanner wrench. See Figure 8.

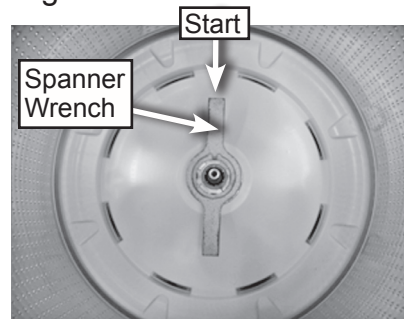

Figure 8

11. Tighten spanner nut 3/4 of a turn by lightly tapping spanner wrench with a hammer. See Figure 9.

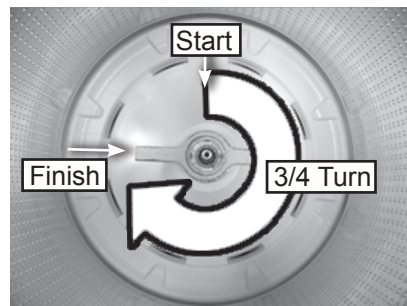

Figure 9

12. Inspect installation. Lift up on on basket with both hands to confirm drive block and basket are correctly assembled to spin tube. As an additional verification there should be approximately a 1/2" gap between the balance ring and tub ring when the basket is completely installed.
13. Install impeller, impeller bolt and cap. For best results install a new impeller bolt.
14. Replace all parts and panels.
15. Plug in washer or reconnect power.

REMOVING THE TUB

⚠ WARNING



Electrical Shock Hazard
Disconnect power before servicing.
Replace all parts and panels before operating.
Failure to do so can result in death or electrical shock.

1. Unplug washer or disconnect power.

⚠ WARNING

Excessive Weight Hazard
Use two or more people to move and install washer.
Failure to do so can result in back or other injury.

2. Turn off the water supply to the washer.
3. Raise the top on the hinges. See the section: "REMOVING THE TOP".
4. Remove harness from control and water valves to set the top aside.
5. Remove the basket. See the section REMOVING THE IMPELLER BOLT AND BASKET.
6. Remove suspension rods from balls, see figure 1.
11. Hang the rods on the top edge of the tub ring.
12. Lift tub out, see figure 3.

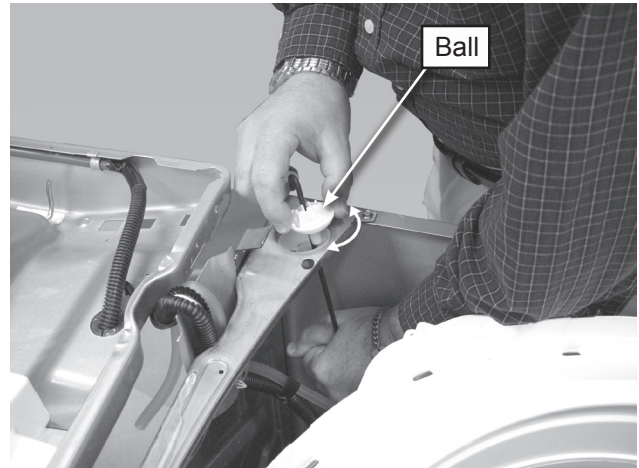

Figure 1



Figure 2



Figure 3

—NOTES—

FOR SERVICE TECHNICIANS ONLY

Testing

⚠ DANGER



Electrical Shock Hazard

Only authorized technicians should perform diagnostic voltage measurements.

After performing voltage measurements, disconnect power before servicing.

Failure to follow these instructions can result in death or electrical shock.

⚠ WARNING



Electrical Shock Hazard

Disconnect power before servicing.

Replace all parts and panels before operating.

Failure to do so can result in death or electrical shock.

Voltage Measurement Safety Information

When performing live voltage measurements, you must do the following:

- Verify the controls are in the off position so that the appliance does not start when energized.
- Allow enough space to perform the voltage measurements without obstructions.
- Keep other people a safe distance away from the appliance to prevent potential injury.
- Always use the proper testing equipment.
- After voltage measurements, always disconnect power before servicing.

IMPORTANT: Electrostatic Discharge (ESD) Sensitive Electronics

ESD problems are present everywhere. ESD may damage or weaken the electronic control assembly. The new control assembly may appear to work well after repair is finished, but failure may occur at a later date due to ESD stress.

- Use an antistatic wrist strap. Connect wrist strap to green ground connection point or unpainted metal in the appliance

-OR-

Touch your finger repeatedly to a green ground connection point or unpainted metal in the appliance.

- Before removing the part from its package, touch the antistatic bag to a green ground connection point or unpainted metal in the appliance.
- Avoid touching electronic parts or terminal contacts; handle electronic control assembly by edges only.
- When repackaging failed electronic control assembly in antistatic bag, observe above instructions.

FOR SERVICE TECHNICIANS ONLY

ACTIVATING THE SERVICE DIAGNOSTIC MODES

1. Be sure the washer is in standby mode (plugged in with all indicators off).
2. Perform the following sequence of movement using the cycle selector knob.
NOTE: AFTER RESET, sequence "a" through "e" must be completed within 6 seconds.



RESET - Rotate cycle selector knob counterclockwise to clear sequence.



a. Rotate cycle selector knob clockwise one click and wait ½ second.



b. Rotate cycle selector knob clockwise one click and wait ½ second.



c. Rotate cycle selector knob clockwise one click and wait ½ second.



d. Rotate cycle selector knob counterclockwise one click and wait ½ second.



e. Rotate cycle selector knob clockwise one click.

- Successful activation of this test mode will be indicated by all status LED's flashing ON and OFF in half-second intervals.

Legend: = ON = OFF

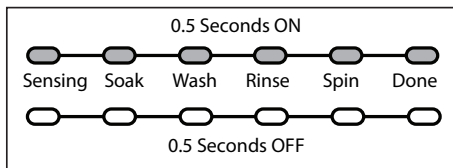

Figure 1 - Successful Activation of Test Mode

- If LED indicators do not display as described above, the sequence may not have been completed within 6 seconds. Repeat step 2 to ensure this was not the cause. If still unsuccessful, see Unsuccessful Entry at right.

3. There are several Diagnostic Test Modes you can access that are shown in the chart below. To select the desired Mode of Operation, turn the cycle selector knob until the display or status LED's match the mode you wish to enter.

DIAGNOSTIC TEST MODES							
MODE	STATUS LEDs					DISPLAY	
	SENSING	SOAK	WASH	RINSE	SPIN		DONE
Fault Code Display Mode						On	0 1
Automatic Test Mode					On		02
Manual Test Mode					On	On	03
Calibration Mode				On			04
Sales Demo				On		On	05
UI Test Mode				On	On		06
SW Version Display Mode				On	On	On	07

4. Press the START button to enter desired mode of operation.

Refer to the following pages for detailed information on each mode of operation:

- FAULT CODE DISPLAY MODE
- AUTOMATIC TEST MODE
- MANUAL TEST MODE
- CALIBRATION MODE
- SALES DEMO
- UI TEST MODE
- SW VERSION DISPLAY MODE

Unsuccessful Entry

If entry into diagnostic test mode is unsuccessful, refer to the following indication and action:

Indication : None of the LED's or display turn on.

Action: Press POWER button to enter setting mode.

- If indicators come on, repeat steps 1 through 4 of Activating the Service Diagnostic Modes. NOTE: Rotating the dial too fast or too slow will affect entry.

- If no indicators come on after pressing the POWER button, go to TEST #1.

EXITING THE SERVICE DIAGNOSTIC MODES

Press the POWER button at any time to exit diagnostic test modes.

Washer will exit diagnostic test modes after 5 minutes of inactivity or unplugging the power cord.

FOR SERVICE TECHNICIANS ONLY

DIAGNOSTIC GUIDE

Before servicing, check the following:

- Make sure there is power at the wall outlet.
- Has a household fuse blown or circuit breaker tripped? Was a regular fuse used? Inform customer that a time-delay fuse is required.
- Are both hot and cold water faucets open and water supply hoses unobstructed?
- All tests/checks should be made with a VOM (volt-ohm-milliammeter) or DVM (digital-voltmeter) having a sensitivity of 20,000 Ω per volt DC or greater.
- Resistance checks must be made with washer unplugged or power disconnected.
- **IMPORTANT:** Avoid using large diameter probes when checking harness connectors as the probes may deform the connectors upon insertion.
- Check all harnesses and connections before replacing components. Look for connectors not fully seated, broken or loose wires and terminals, or wires not pressed into connectors far enough to engage metal barbs.
- A potential cause of a control not functioning is corrosion or contamination on connections. Use an ohmmeter to check for continuity across suspected connections.

DIAGNOSTIC LED – MAIN CONTROL

A troubleshooting tool has been implemented onto the main control board—a diagnostic LED.
LED ON – The Control is detecting correct incoming line voltage and the processor is functioning.
LED OFF – Control malfunction. Perform TEST #1: Main Control, to verify main control functionality.

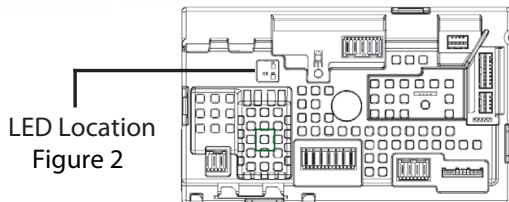

DIAGNOSTIC TEST MODES

These tests allow factory or service personnel to test and verify all inputs to the main control board. You may want to do a quick and overall checkup of the washer with these tests before going to specific troubleshooting tests.

FAULT CODE DISPLAY MODE

To access fault/error codes, perform steps 1 and 2 of Activating the Service Diagnostic Modes. Turn the cycle selector knob until the status LED's or display correspond as follows:

- "Done" LED On, "01" Displayed on 7-segment

○	○	○	○	○	○	○	01
Sensing	Soak	Wash	Rinse	Spin	Done		

Press the START button to enter Fault Code Display Mode.

1. To view last 4 fault codes:
 - Turn cycle selector knob clockwise to view fault codes in the order of most recent to oldest. (Refer to Fault/Error Code charts)

NOTE: A fault/error code will be removed from memory if it does not reoccur after 10 consecutive wash cycles.

2. To clear fault codes:
 - Turn cycle selector knob until the status LED's correspond as follows:

○	○	○	○	○	○
Sensing	Soak	Wash	Rinse	Spin	Done
 - Press and hold START button for 3 seconds to clear all fault codes.

Fault/Error Code Display Method

Fault/error codes are displayed by alternating the state of the Status LED's and display (if display exists) in one-second intervals. All fault/error codes have an F# and an E#. The F# indicates "Type of Fault" and the E# indicates "Component system where fault is located."

*If the Sensing LED is ON the Fault Number is represented; if OFF, the Error Number is represented (see example below). The remaining LED's (Wash, Rinse, Spin, and Done) represent the fault and error code. (See Fault/Error Code Charts for more information.)

FAULT NUMBER						ERROR NUMBER					
Status LEDs					DISPLAY	Status LEDs					DISPLAY
SENSING*	WASH	RINSE	SPIN	DONE		SENSING*	WASH	RINSE	SPIN	DONE	
On			On	On	F3				On	On	F4

NOTE: LED names will vary on selected models.

FOR SERVICE TECHNICIANS ONLY

AUTOMATIC TEST MODE

To access Automatic Test Mode, perform steps 1 and 2 of Activating the Service Diagnostic Modes. Turn the cycle selector knob until the status LED's or display correspond as follows:

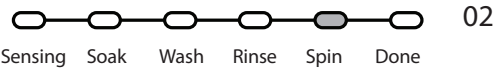
- "Spin" LED On, " 02" Displayed on 7-segment
- 

Press the START button to begin the automatic test.

- Upon entering the automatic test mode, the washer will perform an automatic test with water cycles to check major washer functions.
- Pressing the START button will manually advance to the next step.

NOTE: Lid must be closed with lid lock enabled to perform test.

MANUAL TEST MODE

To access Manual Test Mode, perform steps 1 and 2 of Activating the Service Diagnostic Modes. Turn the cycle selector knob until the status LED's or display correspond as follows:

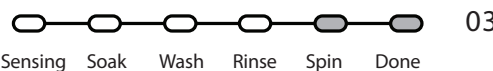
- "Spin & Done" LED On, " 03" Displayed on 7-segment
- 

Press the START button to enter Manual Test Mode.

- Upon entering the manual test mode, the washer will have all outputs OFF.
- The cycle selector knob is used to select the output to be tested.
- When the selected output is activated, the corresponding status LED's flash ON & OFF.
- The START button will activate/deactivate the selected output.

IMPORTANT: As a safety feature, the lid must be closed with lid lock enabled to activate either Agitate or Spin Test.

NOTE: Multiple outputs may be activated simultaneously.

NOTE: Outputs left on will time-out after 5 minutes.

CALIBRATION MODE

IMPORTANT: Calibration must be performed when any of the following components have been replaced: Main Control, Basket, Drive Assembly, Motor, and Capacitor. Not performing calibration will result in poor wash performance.

To access Calibration Mode, perform steps 1 and 2 of Activating the Service Diagnostic Modes. Turn the cycle selector knob until the status LED's or display correspond as follows:

- "Rinse" LED On, " 04" Displayed on 7-segment
- 

Press the START button to begin washer calibration.

- Lid must be down to perform test.
- Basket must be empty to perform test (no water or clothes).
- Calibration cycle runs for approximately 2-3 minutes. Cycle completes when door unlocks and washer enters standby mode.
- Do NOT interrupt calibration, disturb washer, remove power, or press POWER button; otherwise, calibration must be repeated.

SALES DEMO MODE

NOTE: For retail use only. To access Sales Demo Mode, perform steps 1 and 2 of Activating the Service Diagnostic Modes. Turn the cycle selector knob until the status LED's or display correspond as follows:

- "Rinse & Done" LED On, " 05" Displayed on 7-segment
- 

Press the START button to begin the Sales Demo.

- To exit Sales Demo Mode, the washer must be powered down. It may be necessary to unplug the washer or disconnect power to disable the Sales Demo.

FOR SERVICE TECHNICIANS ONLY

UI TEST MODE

To access UI (User Interface) Test Mode, perform steps 1 and 2 of Activating the Service Diagnostic Modes. Turn the cycle selector knob until the status LED's or display correspond as follows:

- "Rinse & Spin" LED On, " 06" Displayed on 7-segment

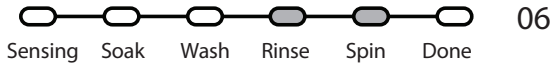

Press the START button to begin the UI test.

NOTE: Features and terminology may vary between makes and models.

- Upon entering the UI test mode, all LED's and display (if it exists) will be turned ON.
- Pressing the POWER button will deactivate the UI test mode.
- When rotating the cycle selector knob, each click "indent" toggles the "Done" LED as well as the associated cycle LED.
- Pressing the START button will toggle the display, start, and status indicators on and off.
- Pressing each button will toggle its respective indicator(s) ON or OFF.
- Each press of the EcoBoost button toggles the EcoBoost and EcoMonitor indicators ON and OFF (not available on all models).

SOFTWARE VERSION DISPLAY MODE

To access Software Version Display Mode, perform steps 1 and 2 of Activating the Service Diagnostic Modes. Turn the cycle selector knob until the status LED's or display correspond as follows:

- "Rinse, Spin, and Done" LED On, " 07 " Displayed on 7-segment

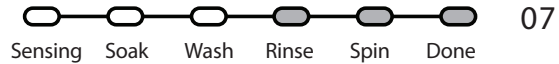

Press the START button to begin software display mode.

- Upon entering the software version display mode, the Major, Minor, and Test version numbers for the software are displayed by alternating the state of the Status LEDs and display (if display exists) in one second intervals; the process repeats following a pause.

For example, if the s/w version is 02.01.07, the following sequence would be displayed:

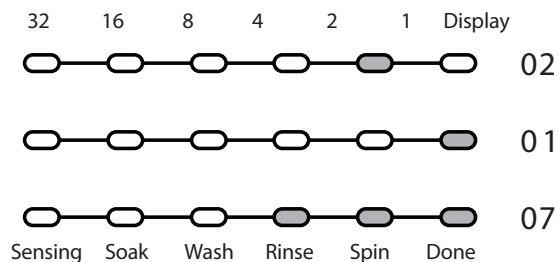

CUSTOMER VIEWABLE FAULT CODES

There are 3 fault codes that may be visible to the customer indicated by the following Status LEDs:

- WASH LED ON (Long Fill Fault) – Refer to "No Fill, Long Fill"
- SPIN LED ON (Long Drain Fault) – Refer to "Long Drain"
- LID LOCK LED FLASHING CONTINUOUSLY (Lid Lock Fault) – Refer to "Lid Lock Fault" on following page for information.

FOR SERVICE TECHNICIANS ONLY

FAULT/ERROR CODES (continued) — See page to access Fault Code Display Mode

DESCRIPTION	FAULT NUMBER						ERROR NUMBER					
	Status LEDs					DISPLAY	Status LEDs					DISPLAY
Explanation & Recommended Procedure	SENSING*	WASH	RINSE	SPIN	DONE		SENSING*	WASH	RINSE	SPIN	DONE	
OVER SUDS CONDITION DETECTED	On					F0				On		E2
Fault is displayed when Suds prevent the basket from spinning up to speed or the pressure sensor detects rising suds level. The main control will flush water in attempt to clear Suds. If the water flush is unable to correct the problem, this may indicate: <ul style="list-style-type: none"> • Not using HE detergent. • Excessive detergent usage. • Check pressure hose connection from tub to main control. Is hose pinched, kinked, plugged, or leaking air? • Mechanical friction on drive mechanism or basket. (Clothing between basket and tub.) 												
HIGH WATER TEMPERATURE – RINSE CYCLE	On					F0			On			E4
Fault is displayed when washer detects water temperature 105° or higher during rinse cycle. <ul style="list-style-type: none"> • Hot water getting in. Make sure inlet hoses are connected correctly. • If hoses are installed properly, temperature thermistor may be stuck in low resistance range. • See TEST #5: Temperature Thermistor. 												
OFF BALANCE LOAD DETECTED	On					F0			On	On		E5
Fault is displayed when an off balance condition is detected. <ul style="list-style-type: none"> • Check for weak suspension. Basket should not bounce up and down more than once when pushed. • Clothing should be distributed evenly when loading. 												
MAIN CONTROL FAULT	On				On	F1				On		E1
Indicates a main control fault. <ul style="list-style-type: none"> • See TEST #1: Main Control. 												
MOTOR CONTROL FAULT	On				On	F1				On		E2
Indicates a fault of the motor control section of the main control. <ul style="list-style-type: none"> • See TEST #3b: Drive System. 												
STUCK KEY	On			On		F2					On	E1
One or more keys on the User Interface were actuated for 15 consecutive seconds. <ul style="list-style-type: none"> • Fault occurs during Diagnostic Test Mode if a stuck key is detected. • See TEST #4: Consoles and Indicators. 												
MISMATCH OF MAIN CONTROL & UI	On			On		F2				On	On	E3
The User Interface identification does not match the expected value in the Main Control Board. <ul style="list-style-type: none"> • Fault occurs during Diagnostic Test Mode if a mismatch of main control and UI is identified. • See TEST #4: Consoles and Indicators. 												
PRESSURE SENSOR FAULT	On			On	On	F3					On	E1
Fault is displayed when the Main Control detects an out of range pressure signal. <ul style="list-style-type: none"> • Check pressure hose connection from tub to main control. Is hose pinched, kinked, plugged, or leaking air? • See TEST #6: Water Level. 												
INLET WATER TEMPERATURE FAULT	On			On	On	F3				On		E2
Fault is displayed when the Inlet Thermistor is detected to be open or shorted. <ul style="list-style-type: none"> • See TEST #5: Temperature Thermistor. 												
LID SWITCH FAULT	On		On		On	F5					On	E1
Fault is displayed if Lid Switch has not been detected after multiple wash cycles. <ul style="list-style-type: none"> • User presses START with lid open. • The main control cannot detect the lid switch opening and closing properly. • See TEST #8: Lid Lock. 												
LID LOCK FAULT	On		On		On	F5				On		E2
Fault is displayed if Lid Lock has not moved into locked position or motor cannot be powered. <ul style="list-style-type: none"> • Lid is not closed completely due to interference. • Check for lock interference with lock striker. • Wash media buildup (detergent, lint, etc.) is preventing the lock mechanism from sliding. • Main control detects open lid switch when attempting to lock. • Main control cannot determine if lid lock is in a locked state. • See TEST #8: Lid Lock. 												

* If the Sensing LED is ON, the fault code number is represented; if OFF, the error code number is represented.

FOR SERVICE TECHNICIANS ONLY

FAULT/ERROR CODES (continued) — See page to access Fault Code Display Mode

DESCRIPTION	FAULT NUMBER						ERROR NUMBER					
	Status LEDs					DISPLAY	Status LEDs					DISPLAY
Explanation & Recommended Procedure	SENSING*	WASH	RINSE	SPIN	DONE		SENSING*	WASH	RINSE	SPIN	DONE	
LID UNLOCK FAULT	On		On		On	F5				On	On	E3
Fault is displayed if Lid Lock has not moved into unlocked position or motor cannot be powered. <ul style="list-style-type: none"> • Check for lock interference with lock striker. • Main control cannot determine if lid lock is in an unlocked state. • See TEST #8: Lid Lock. 												
LID NOT OPENED BETWEEN CYCLES	On		On		On	F5			On			E4
Fault is displayed if the following conditions occur: <ul style="list-style-type: none"> • User presses START after several consecutive washer cycles without opening lid. • See TEST #8: Lid Lock. 												
BASKET SPEED SENSOR FAULT	On		On	On	On	F7				On		E1
Fault is displayed when the main control cannot determine speed of basket. <ul style="list-style-type: none"> • Locked rotor—check that basket, impeller, and motor can rotate freely. • Check harness connections from main control to motor and shifter. • See TEST #3a: Drive System–Shifter. 												
SHIFTER FAULT	On		On	On	On	F7			On		On	E5
Fault is displayed when the main control cannot determine position of shifter. <ul style="list-style-type: none"> • Check harness connections from main control to motor and shifter. • Observe shifter operation. • See TEST #3a: Drive System–Shifter. 												
MOTOR FAULT	On		On	On	On	F7			On	On		E5
Indicates an open clockwise or counterclockwise circuit of the motor. <ul style="list-style-type: none"> • See TEST #3b: Drive System–Motor. 												
MOTOR UNABLE TO REACH TARGET RPM	On		On	On	On	F7			On	On	On	E5
Fault is displayed when basket speed sensor detects that target RPM was not reached. <ul style="list-style-type: none"> • Mechanical friction on drive mechanism or basket (clothing between basket and tub). • Weak motor or run capacitor. • Load off balance. Clothing should be distributed evenly when loading. • See TEST #3b: Drive System–Motor. 												
NO FILL, LONG FILL	On	On				F8					On	E1
Fault is displayed when the water level does not change for a period of time OR water is present but main control does not detect the water level changing. <ul style="list-style-type: none"> • Is water supply connected and turned on? • Low water pressure; fill times longer than six minutes. Are hose screens plugged? • Check for proper drain hose installation. Is water siphoning out of the drain hose? • Drain hose must not be more than 4.5" (113mm) into the drain pipe. • Check pressure hose connection from tub to main control. Is hose pinched, kinked, plugged, or leaking air? • See TEST #2: Valves. 												
OVERFLOW CONDITION	On	On				F8				On	On	E3
Fault is displayed when main control senses water level that exceeds the washer's capacity. <ul style="list-style-type: none"> • May signify problem with inlet water valves. • Check pressure hose connection from tub to main control. Is hose pinched, kinked, plugged, or leaking air? • Pressure transducer fault on main control. • See TEST #2: Valves and TEST #6: Water Level. 												
HOT, COLD REVERSED	On	On				F8			On		On	E5
Fault is displayed when the hot and cold inlet hoses are reversed. <ul style="list-style-type: none"> • Make sure inlet hoses are connected correctly. • If hoses are installed properly, temperature thermistor may be stuck in low resistance range. • See TEST #2: Valves and TEST #5: Temperature Thermistor. 												
LONG DRAIN	On	On			On	F9					On	E1
Fault is displayed when the water level does not change after the drain pump is on for 10 minutes. <ul style="list-style-type: none"> • Is the drain hose or the drain pump clogged? Check tub sump under impeller for obstructions. • Is the drain hose height greater than 96"? • Check pressure hose connection from tub to main control. Is hose pinched, kinked, plugged, or leaking air? • Is the pump running? If not, see TEST #7: Drain Pump. 												

* If the Sensing LED is ON, the fault code number is represented; if OFF, the error code number is represented.

FOR SERVICE TECHNICIANS ONLY

AUTOMATIC TEST MODE —

Press the START button to begin the Automatic Test. **NOTE:** Lid must be closed with lid lock enabled to perform Automatic Test.

FUNCTION	STATUS LEDs							DISPLAY	Est. TIME
	SENSING	SOAK	WASH	RINSE	SPIN	DONE	LID LOCK	If Available	In Seconds
Recommended Procedure									
LID WILL LOCK Motor must be at "0" RPM. If lid does not lock, go to Manual Test.						On	On	01	1
COLD VALVE WILL ACTUATE If water is not present, or temperature is wrong, go to Manual Test.					On		On	02	5
HOT VALVE WILL ACTUATE If water is not present, or temperature is wrong, go to Manual Test: Hot Valve.					On	On	On	03	5
RESERVED FOR FUTURE DEVELOPMENT Washer will pause for 5 seconds.				On			On	04	5
RESERVED FOR FUTURE DEVELOPMENT Washer will pause for 5 seconds.				On		On	On	05	5
FABRIC SOFTENER DISPENSER & COLD VALVE WILL ACTUATE If no water in fabric softener dispenser, go to Manual Test: Fabric Softener Dispenser.				On	On		On	06	5
HOT & COLD VALVE WILL ACTUATE Hot & cold water valves will actuate for the specified time period.				On	On	On	On	07	45
SHIFTER MOVES TO AGITATION POSITION If motor does not agitate, go to Manual Test: Gentle or Heavy Agitation.			On				On	08	~5-15
MOTOR AGITATES If motor does not agitate, go to Manual Test: Gentle or Heavy Agitation.			On			On	On	09	10
DRAIN PUMP WILL ACTUATE If water is not draining, go to Manual Test: Drain.			On		On		On	10	~30-40
SHIFTER MOVES TO SPIN POSITION If basket is not turning, go to Manual Test: Low or High Spin.			On		On	On	On	11	~5-15
MOTOR SPINS If basket is not turning, go to Manual Test: Low or High Spin.			On	On			On	12	10
LID REMAINS LOCKED UNTIL WASHER SENSES A STOPPED BASKET Basket must stop spinning (0 RPM) before test continues to next phase. Time for basket to stop spinning may vary from 30 seconds up to 2 minutes.			On	On		On	On	13	~30-40
LID WILL UNLOCK AND CYCLE COMPLETES If lid does not unlock, go to Manual Test: Lid Lock. If no end-of-cycle tone, make sure Cycle Signal is turned on.			On	On	On			14	1
								Estimated Time	~3 min

FOR SERVICE TECHNICIANS ONLY

MANUAL TEST MODE —

Pressing the START button will activate/deactivate each output. When the output is activated, the corresponding Status LED's will flash. **NOTE:** Lid must be closed and locked to perform SPIN tests.

OUTPUT	STATUS LEDs							DISPLAY
	SENSING	SOAK	WASH	RINSE	SPIN	DONE	LID LOCK	
Output Details NOTE: Outputs will time-out after 5 minutes.								If Available
LID LOCK Lock and unlock the lid. NOTES: When lock is enabled, the "Lid Lock" LED will turn ON. Will only lock when lid is closed. Will only unlock when basket RPM is 0. If lid is not closed, washer will beep and LED's will flash. • If lid does not lock or unlock, go to TEST #8.								00
COLD VALVE Turns ON and turns OFF cold water valve. • If valve does not turn on, go to TEST #2.						On		01
HOT VALVE Turns ON and turns OFF hot water valve. • If valve does not turn on, go to TEST #2.					On			02
RESERVED FOR FUTURE DEVELOPMENT If selected, washer will beep and LED's will flash.					On	On		03
RESERVED FOR FUTURE DEVELOPMENT If selected, washer will beep and LED's will flash.				On				04
FABRIC SOFTENER DISPENSER Turns ON and turns OFF the fabric softener valve. (May not be available on all models or brands.) • If valve does not turn on, go to TEST #2.				On		On		05
OXI DISPENSER Turns ON and turns OFF the Oxi dispenser valve. (May not be available on all models or brands.) • If valve does not turn on, go to TEST #2.				On	On			06
DRAIN Turns ON and turns OFF the drain pump. • If pump does not turn on, go to TEST #7.				On	On	On		07
RESERVED FOR FUTURE DEVELOPMENT If selected, washer will beep and LED's will flash.			On					08
LOW SPIN Allow up to 15 seconds for shifter to reposition. Spins basket from 0 to 500 RPM. IMPORTANT: Water in tub must be drained before test. IMPORTANT: To activate Low Spin, RPM must read "0" and lid must be closed with lid lock enabled. If lid is not closed, washer will beep and LED's will flash. • If motor does not spin, go to TEST #3a & 3b.			On			On	On	09
HIGH SPIN Allow up to 15 seconds for shifter to reposition. Spins basket from 0 to maximum RPM. To activate High Spin, IMPORTANT: Water in tub must be drained before test. IMPORTANT: To activate High Spin, RPM must read "0" and lid must be closed with lid lock enabled. If lid is not closed, washer will beep and LED's will flash. • If motor does not spin, go to TEST #3a & 3b.			On		On		On	10
GENTLE AGITATION Allow up to 15 seconds for shifter to reposition. Shifts from idle motor to gentle CW/CCW agitation. IMPORTANT: To activate Gentle Agitation, RPM must read "0" and lid must be closed with lid lock enabled. If lid is not closed, washer will beep and LED's will flash. • If motor does not agitate, go to TEST #3a & 3b: Drive System (Shifter & Motor).			On		On	On	On	11
HEAVY AGITATION Allow up to 15 seconds for shifter to reposition. Shifts from idle motor to heavy CW/CCW agitation. IMPORTANT: To activate Heavy Agitation, RPM must read "0" and lid must be closed with lid lock enabled. If lid is not closed, washer will beep and LED's will flash. • If motor does not agitate, go to TEST #3a & 3b: Drive System (Shifter & Motor).			On	On			On	12

DIAGNOSTICS FOR SERVICE TECHNICIANS ONLY



! WARNING

Electrical Shock Hazard

Disconnect power before servicing.

Replace all parts and panels before operating.

Failure to do so can result in death or electrical shock.

DIAGNOSTIC GUIDE

Before servicing, check the following:

- Make sure there is power at the wall outlet.
- Has a household fuse blown or circuit breaker tripped? Time delay fuse?
- Are both hot and cold water faucets open and water supply hoses unobstructed?
- All tests/checks should be made with a VOM or DVM having a sensitivity of 20,000 ohms per volt DC or greater.
- Check all connections before replacing components. Look for broken or loose wires, failed terminals, or wires not pressed into connections far enough.
- A potential cause of a control not functioning is corrosion on connections. Observe connections and check for continuity with an ohmmeter.
- Connectors: Look at top of connector. Check for broken or loose wires. Check for wires not pressed into connector far enough to engage metal barbs.
- Resistance checks must be made with power cord unplugged from outlet, and with wiring harness or connectors disconnected.

TROUBLESHOOTING GUIDE FOR SERVICE TECHNICIANS ONLY

⚠ WARNING



Electrical Shock Hazard

Plug into a grounded 3 prong outlet.
Do not remove ground prong.
Do not use an adapter.
Do not use an extension cord.
Failure to follow these instructions can result in death, fire, or electrical shock.

Some tests will require accessing components.

NOTE: Always check for error codes first.

For detailed troubleshooting procedures, refer to “Troubleshooting Tests” .

PROBLEM	POSSIBLE CAUSE	CHECKS & TESTS
WON'T POWER UP • No operation • No keypad response • No LEDs or display	No power to washer.	Check power at outlet, check circuit breakers, fuses, or junction box connections.
	Connection problem between AC plug and main control.	Check the AC power cord for continuity.
	Connections between main control and UI.	Check connections and continuity between main control-J9 and UI.
	Main control problem.	See TEST #1: Main Control.
	User Interface problem.	See TEST #4: Console and Indicators, page 16.
WON'T START CYCLE No response when Start Button is pressed.	Lid lock mechanism not functioning.	1. Lid not closed due to interference. 2. Lock not closed due to interference. 3. See TEST #8: Lid Lock.
	Connections between main control and UI.	Check connections and continuity between main control-J9 and UI.
	User Interface problem.	See TEST #4: Console and Indicators.
	Main Control problem.	See TEST #1: Main Control.
UI WON'T ACCEPT SELECTIONS	Connections between main control and UI.	Check connections and continuity between main control-J9 and UI.
	User Interface problem.	See TEST #4: Console and Indicators.
	Main control problem.	See TEST #1: Main Control.
CYCLE TIME LONGER THAN EXPECTED	Oversuds.	1. Verify use of HE detergent. 2. Excessive detergent usage.
	Off balance.	1. Load is off balance. 2. Balance ring water leak.
	Weak suspension.	Basket should not bounce up and down more than once when pushed.
WON'T FILL	No water supplied to washer.	1. Check water connections to washer. 2. Verify hot and cold water supply is on.
	Plugged filter/screen.	Check for plugged filter or screen in the water valve or hoses.
	Drain hose installation.	Check for proper drain hose installation.
	Valve problem.	See TEST #2.
	Main control problem.	See TEST #1: Main Control.

TROUBLESHOOTING GUIDE (continued) FOR SERVICE TECHNICIANS ONLY

WON'T DISPENSE FABRIC SOFTENER OR OXI	No water supplied to washer.	1. Check water connections to washer. 2. Verify hot and cold water supply is on.
	Obstruction in dispenser.	Clean obstruction from dispenser.
	Valve problem.	See TEST #2: Valves.
	Main control problem.	See TEST #1: Main Control.
WON'T AGITATE	Water covering impeller?	See TEST #6: Water Level.
	Is lid lock showing open during cycle?	See TEST #8: Lid Lock.
	Drive belt.	Verify that drive belt is not damaged.
	Harness connections.	Check harness connections between main control and drive system.
	Shifter problem.	See TEST #3a: Drive System–Shifter, page 13.
	Motor problem.	See TEST #3b: Drive System–Motor, page 14.
	Tachometer issue.	No tub movement or tub speed out of normal range (obstruction/belt/motor).
	Main control problem.	See TEST #1: Main Control.

TROUBLESHOOTING GUIDE (continued)

FOR SERVICE TECHNICIANS ONLY

Some tests will require accessing components. See Figures 7 & 8 for component locations. For detailed troubleshooting procedures, refer to "Troubleshooting Tests".

PROBLEM	POSSIBLE CAUSE	CHECKS & TESTS
WON'T SPIN	Is lid lock showing open during the cycle?	See TEST #8: Lid Lock.
	Drive belt.	Verify that drive belt is not damaged.
	Harness connections.	Check harness connections between main control and drive system.
	Shifter problem.	See TEST #3a: Drive System–Shifter.
	Motor problem.	See TEST #3b: Drive System–Motor.
	Tachometer issue.	No tub movement or tub speed out of normal range (obstruction/belt/motor).
	Main control problem.	See TEST #1: Main Control.
OVERFILLS	Pressure hose.	See TEST #6: Water Level.
	Valve problem.	See TEST #2: Valves.
	Washer requires calibration.	Perform washer calibration.
	Pressure transducer on main control.	See TEST #1: Main Control.
WON'T DRAIN	Drain hose installation.	Check for proper drain hose installation. Make sure it is not inserted more than 4.5" (113mm).
	Plugged drain hose.	Check drain hose for obstructions.
	Obstructions to drain pump.	Check tub sump under impeller plate & basket for obstructions.
	Harness connections.	Check harness connections between main control and drain pump.
	Drain pump.	See TEST #7: Drain Pump.
	Main control problem.	See TEST #1: Main Control.
INCORRECT WATER TEMPERATURE	Water hose installation.	Make sure inlet hoses are connected properly.
	Temperature thermistor.	See TEST #5: Temperature Thermistor.
	Main control problem.	See TEST #1: Main Control.
POOR WASH PERFORMANCE Please reference Use & Care Guide	Oversuds.	1. Verify use of HE detergent. 2. Excessive detergent usage.
	Load is tangling.	1. Washer not loaded properly. 2. Perform washer calibration.
	Incorrect water level.	1. Perform washer calibration. 2. See TEST #2: Valves. 3. See TEST #6: Water Level.
	Clothes wet after cycle is complete.	1. Overloaded washer. 2. Oversuds (see above). 3. Items caught in in tub sump. 4. Weak suspension. See TEST #7: Drain Pump.
	Load not rinsed.	1. Check proper water supply. 2. Not using HE detergent. 3. Washer not loaded properly. 4. See TEST #2: Valves.
	Not cleaning clothes.	1. Washer not loaded properly. 2. Not using HE detergent. 3. Not using correct cycle. 4. Not using dispensers.
	Fabric damage.	1. Washer overloaded. 2. Bleach added incorrectly. 3. Sharp items in tub.
	Wrong option or cycle selection.	Refer customer to "Use & Care Guide"
ERROR CODE INDICATED	Customer codes: Wash LED on, Spin LED on, Lid Lock LED flashing.	See Customer Viewable Fault Codes on page 5.
	Service Diagnostic Mode Fault Codes.	See Fault/Error Codes.

TROUBLESHOOTING GUIDE (continued) FOR SERVICE TECHNICIANS ONLY

⚠ WARNING

Electrical Shock Hazard Disconnect power before servicing. Replace all parts and panels before operating. Failure to do so can result in death or electrical shock.

TROUBLESHOOTING TESTS

TEST #1: Main Control

This test checks for incoming and outgoing power to and from main control. This test assumes that proper voltage is present at the outlet.

1. Unplug washer or disconnect power.
2. Remove console to access main control.
3. Check the AC power cord for continuity.
4. Verify that ALL connectors are inserted all the way into the main control.
5. Plug in washer or reconnect power.
6. Is the “Diagnostic LED” ON or OFF?
 - ON: (+5VDC present) continue to step 8.
 - OFF: (+5VDC missing) proceed to step 7.
7. With a voltmeter set to DC, connect black probe to J9-3 (Circuit Gnd) and red probe to J9-1 (+5VDC).
 - If +5VDC is present, go to step 8.
 - If +5VDC is not present, go to step 9.
8. With a voltmeter set to DC, connect black probe to J9-3 (Circuit Gnd) and red probe to J9-8 (+13VDC).
 - If +13VDC (and +5VDC) are present, and UI is unresponsive, go to Test #4: Console and Indicators, page 16.
 - If +13VDC is not present, go to step 9.
9. Check if shifter assembly is affecting the main control DC supplies.
 - a. Unplug washer or disconnect power.
 - b. Remove connector J2 from main control.
 - c. Plug in washer or reconnect power.
 - d. Recheck the DC voltages per steps 7 & 8.
 - If the DC voltages return, replace shifter assy.
 - If one or more DC voltages are still missing, go to step 10.
10. Check if console UI is affecting the main control DC supplies.
 - a. Unplug washer or disconnect power.
 - b. Remove connector J9 from main control.
 - c. Plug in washer or reconnect power.
 - d. Recheck the DC voltages per steps 7 & 8. Perform voltage checks inside header J9 on the board – do not short pins together.
 - If the DC voltages return, replace console UI.
 - If one or more DC voltages are still missing, go to step 11.
11. Main Control has malfunctioned.
 - a. Unplug washer or disconnect power.
 - b. Replace the main control.
 - c. Reassemble all parts and panels.
 - d. Plug in washer or reconnect power. Calibrate washer and perform Automatic Test to verify repair.

TROUBLESHOOTING GUIDE (continued) FOR SERVICE TECHNICIANS ONLY

Main Control Board Connectors and Pinouts (Figure 3)

<p>SHIFTER</p> <p>J2</p> <ul style="list-style-type: none"> J2-5 OPEN J2-4 BLK +13VDC J2-3 GRY -5VDC (CIRCUIT GND) J2-2 PNK RPM INPUT J2-1 BLU SHIFTER POSITION INPUT 	<p>CONSOLE UI</p> <p>J9</p> <ul style="list-style-type: none"> J9-8 WHT +13VDC J9-7 WHT BUZZER J9-6 WHT CLOCK J9-5 WHT DATA OUT J9-4 WHT STROBE J9-3 WHT -5VDC (CIRCUIT GND) J9-2 WHT DATA IN J9-1 BLK +5VDC
<p>TEMP</p> <p>J3</p> <ul style="list-style-type: none"> J3-10 GRY TEMP THERMISTOR INPUT J3-9 BLK TEMP THERMISTOR GND J3-8 OPEN J3-7 ORN FAB-SOFT VALVE (L1) J3-6 BRN OXI VALVE (L1) J3-5 BLU COLD VALVE (L1) J3-4 RED HOT VALVE (L1) J3-3 OPEN J3-2 OPEN J3-1 WHT NEUTRAL 	<p>LID LOCK</p> <p>J15</p> <ul style="list-style-type: none"> J15-4 RED LOCK SWITCH J15-3 WHT NEUTRAL J15-2 BLU LID SWITCH INPUT J15-1 YEL LOCK SWITCH SOLENOID (L1)
<p>POWER CORD</p> <p>J7</p> <ul style="list-style-type: none"> J7-3 BLK NEUTRAL J7-2 GRN CHASSIS GROUND J7-1 BLK L1 	<p>DRAIN MOTOR</p> <p>J16</p> <ul style="list-style-type: none"> J16-7 ORN MOTOR CCW WINDING (L1) J16-6 RED MOTOR CW WINDING (L1) J16-5 WHT MOTOR (NEUTRAL) J16-4 OPEN J16-3 LT BLU DRAIN PUMP MOTOR (L1) J16-2 WHT BLU SHIFTER MOTOR (NEUTRAL) J16-1 BRN SHIFTER MOTOR (L1)

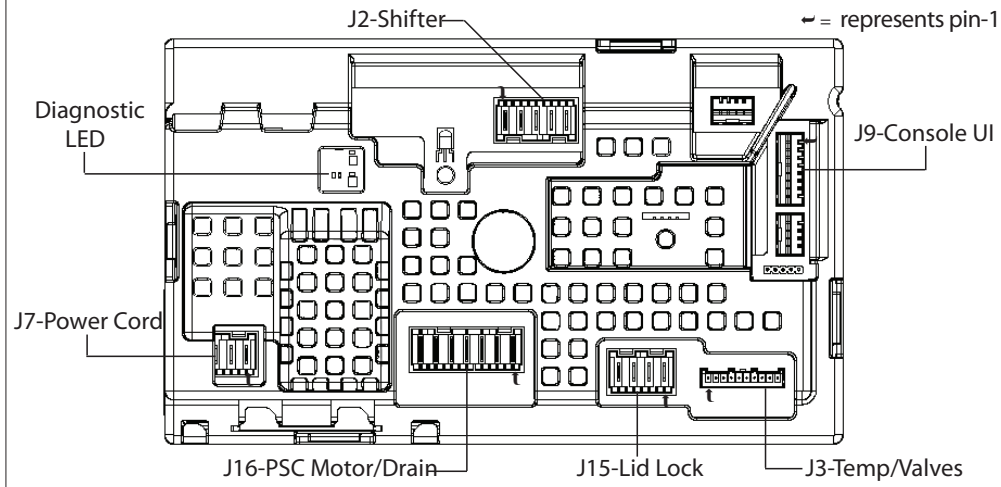

TROUBLESHOOTING GUIDE (continued) FOR SERVICE TECHNICIANS ONLY

⚠ **WARNING**



Electrical Shock Hazard

Disconnect power before servicing.
Replace all parts and panels before operating.
Failure to do so can result in death or electrical shock.

TEST #2: Valves

This test checks the electrical connections to the valves, and the valves themselves.

1. Check the relays and electrical connections to the valves by performing the Cold, Hot, Oxi, and Fabric Softener Valve tests under Manual Test Mode. Each test activates and deactivates the selected valve. The following steps assume one (or more) valve(s) did not turn on.
2. For the valve(s) in question check the individual solenoid valves:
 - a. Unplug washer or disconnect power.
 - b. Remove console to access main control.
 - c. Remove connector J3 from main control. Refer to main control diagram on page 12.
 - d. Check harness connection to solenoid valves.
3. Check resistance of the valve coils across the following J3 connector pinouts:

Valve	Pinout
Hot Valve	J3, 1 & 4
Cold Valve	J3, 1 & 5
Oxi Valve	J3, 1 & 6
Fabric Softener Valve	J3, 1 & 7

Resistance should be between 890–1.3k Ω.

- If resistance readings are tens of ohms outside of range, replace the valve assembly.
- If resistance readings are within range, replace main control and calibrate washer.

Perform automatic test to verify repair.

TEST #3a: Drive System – Shifter

This test checks connections, shifter motor, switch, and optical sensor.

NOTE: Refer to Figure 4, “Shifter Assembly Strip Circuit” for tests and measurements.

IMPORTANT: Drain water from tub before accessing bottom of washer.

Functional Check:

1. Check the shifter and electrical connections by performing both the Spin AND Agitate test under Manual Test Mode. The following steps assume that this step was unsuccessful.
2. Unplug washer or disconnect power.
3. Check to see if basket will turn freely.
 - If basket turns freely, go to step 4.
 - If basket does not turn freely, determine what is causing the mechanical friction or lockup.
4. Remove console to access main control.
5. Visually check that the J2 and J16 connectors are inserted all the way into the main control.
 - If visual checks pass, go to step 6.
 - If connectors are not inserted properly, reconnect J2 and J16 and repeat step 1.

Shifter Motor:

6. Remove connector J16 from main control. With an ohmmeter, verify resistance values shown below across the following J16 connector pinouts:

Component	J16 Connector Pinout
Shifter Motor	J16, 1 & 2

TROUBLESHOOTING GUIDE (continued) FOR SERVICE TECHNICIANS ONLY

Resistance should be between 2k to 3.5k Ω .

- If values are correct, reconnect J16 and proceed to step 7.
- If values are open or out of range, go to step 13.

7. Plug in washer or reconnect power.

8. With a voltmeter set to AC, connect the black probe to J16-2 (N) and red probe to J16-1 (L1). Activate shifter motor by switching between Spin and Agitate modes. Energize outputs using Manual Test Mode.

IMPORTANT: Lid must be closed with Lid Lock enabled to run the SPIN and AGITATE tests.

NOTE: It will take between 4-15 seconds for the shifter to change states.

- If 120VAC is present, go to step 9.
- If 120VAC is not present, to step 17.

Shifter Switch:

9. With a voltmeter set to DC, connect the black probe to J2-3 (Circuit Gnd) and red probe to J2-1 (Shifter Switch). In manual test mode, switch between Spin and Agitate modes. Voltage should toggle between 0 and +5VDC.

SPIN = +5 VDC

AGITATE = 0 VDC

- If voltage corresponds to setting, go to step 10.
- If voltage does not switch, go to step 12.

Optical Sensor:

10. With a voltmeter set to DC, connect the black probe to J2-3 (Circuit Gnd) and red probe to J2-4 (+13VDC).

- If +13VDC is present, go to step 11.
- If +13VDC is not present, go to step 17.

11. With a voltmeter set to DC, connect the black probe to J2-3 (Circuit Gnd) and red probe to J2-2 (RPM input). Slowly turn drum by hand. Voltage should toggle between 0 and +5VDC.

- If voltage is not confirmed, go to step 12.
- If voltage is confirmed, go to step 17.

12. Unplug washer or disconnect power.

13. Tilt washer back to access the bottom of the washer and the drive motor area.

14. Visually check the electrical connections to the shifter.

- If visual check passes, go to step 15.

If connections are loose, reconnect the electrical connections and repeat step 1.

15. With an ohmmeter, check the harness for continuity between the shifter and main control using the following pinouts. See chart below.

Motor Harness Check
Motor Connector Pin-1 to Chassis Ground
Motor Connector Pin-3 to Main Control J16-7
Motor Connector Pin-3 to Run Capacitor Pin-3
Motor Connector Pin-6 to Main Control J16-6
Motor Connector Pin-6 to Run Capacitor Pin-1
Motor Connector Pin-9 to Main Control J16-5

- If there is continuity, go to step 16.

- If there is no continuity, replace the lower machine harness and repeat step 1.

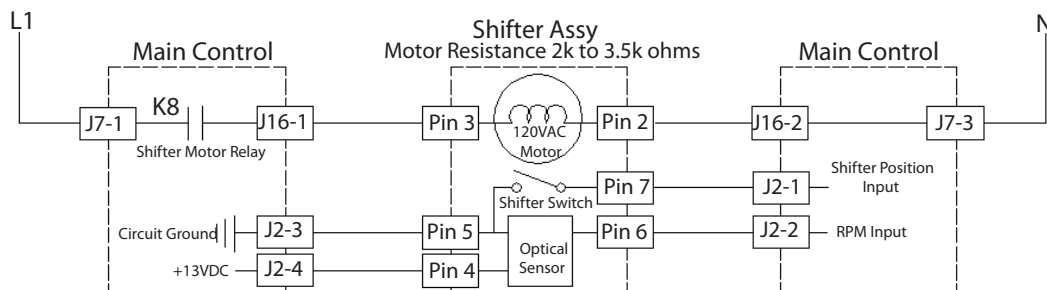

Figure 4 - Shifter Assembly Strip Circuit (Shifter Switch Open = SPIN, Closed = AGITATE)

TROUBLESHOOTING GUIDE (continued) FOR SERVICE TECHNICIANS ONLY

⚠ WARNING



Electrical Shock Hazard

Disconnect power before servicing.

Replace all parts and panels before operating.

Failure to do so can result in death or electrical shock.

16. Replace the shifter assembly.
 - a. Unplug washer or disconnect power.
 - b. Replace shifter assembly.
 - c. Reassemble all parts and panels.
 - d. Plug in washer or reconnect power. Calibrate washer and perform Automatic Test to verify repair.
17. Replace main control.
 - a. Unplug washer or disconnect power.
 - b. Replace the main control.
 - c. Reassemble all parts and panels.
 - d. Plug in washer or reconnect power. Calibrate washer and perform Automatic Test to verify repair.

TEST #3b: Drive System – Motor

This test checks the motor, motor windings, wiring, and start capacitor.

NOTE: Refer to Figure 5, “PSC Motor Strip Circuit” on page 15 for tests and measurements.

IMPORTANT: Drain water from tub before

accessing bottom of washer.

1. Check the motor and electrical connections by performing the Gentle or Heavy Agitation test under Manual Test Mode. The following steps assume that this step was unsuccessful.
2. Unplug washer or disconnect power.
3. Check to see if basket will turn freely.
 - If basket turns freely, go to step 4.
 - If basket does not turn freely, determine what is causing the mechanical friction or lockup.
4. Remove console to access main control.
5. Visually check that the J2 and J16 connectors are inserted all the way into the main control.
 - If visual checks pass, go to step 6.
 - If connectors are not inserted properly, reconnect J2 and J16 and repeat step 1.
6. Plug in washer or reconnect power. Run the Gentle Agitation test under Manual Test Mode.
7. With a voltmeter set to AC; connect black probe to J16-5 (N) and red probe to J16-6 (CW Winding).
 - If 120VAC is cycling ON during CW rotation, go to step 8.
 - If 120VAC is not present, go to Test #1: Main Control, page 12.
8. With a voltmeter set to AC, connect black probe to J16-5 (N), red probe to J16-7 (CCW Winding).
 - If 120VAC is cycling ON during CCW rotation, go to step 9.
 - If 120VAC is not present, go to Test #1: Main Control.

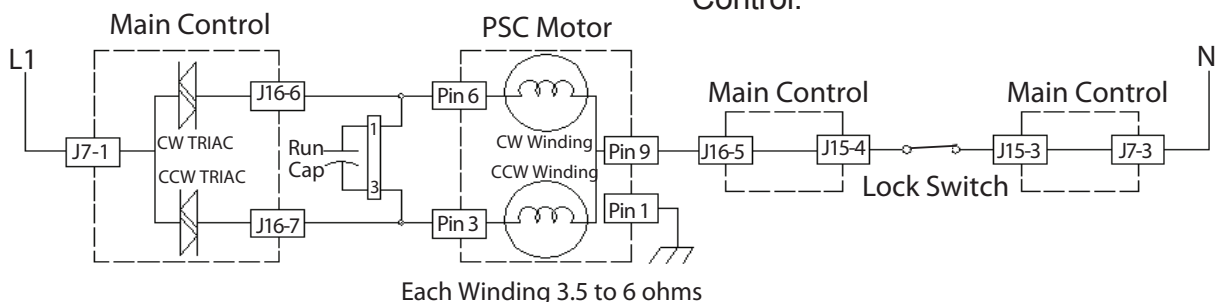

Each Winding 3.5 to 6 ohms

Figure 5 - PSC Motor Strip Circuit (shown in ON position)

TROUBLESHOOTING GUIDE (continued) FOR SERVICE TECHNICIANS ONLY

9. Unplug washer or disconnect power.
10. Remove connector J16 from main control. With an ohmmeter, verify resistance values shown below across the following J16 connector pinouts:

Motor Winding	J16 Connector Pinout
CW Winding	J16, 5 & 6
CCW Winding	J16, 5 & 7

Resistance should be between 3.5 and 6 Ω.

- If values are correct, go to step 15.
11. Tilt washer back to access the bottom of the washer and the drive motor area.
 12. Visually check the mounting bracket and electrical connections to the motor and shifter.
 - If visual check passes, go to step 13.
 - If connections are loose, reconnect the electrical connections, reassemble motor cover, and repeat step 1.
 13. With an ohmmeter, check the harness for continuity between the main control, motor, and run capacitor using the following test points. See chart.

Motor Harness Check
Motor Connector Pin-1 to Chassis Ground
Motor Connector Pin-3 to Main Control J16-7
Motor Connector Pin-3 to Run Capacitor Pin-3
Motor Connector Pin-6 to Main Control J16-6
Motor Connector Pin-6 to Run Capacitor Pin-1
Motor Connector Pin-9 to Main Control J16-5

- If there is continuity, go to step 14.
 - If there is no continuity, replace the lower machine harness and repeat step 1.
14. With an ohmmeter, check the motor windings at the following motor connections.

Motor Winding	Motor Pinout
CW Winding	Pins 4 & 6
CCW Winding	Pins 3 & 6

Resistance should be between 3.5 and 6 Ω.

- If values are open or out of range, replace motor.
- If values are correct, go to step 15.

15. Test Motor Run Capacitor. NOTE: A faulty capacitor may cause the motor to “hum”, not start, or turn slowly.
 - a. Disconnect one wire terminal from the capacitor.
 - b. Discharge capacitor by placing a resistance across the terminals.
 - c. With an ohmmeter, measure across the terminals and note reading.
 - If a steady increase in resistance is noted, continue to step 16.
 - If the capacitor is either shorted or open, replace capacitor, calibrate, and repeat step 1.
16. If the preceding steps did not correct the motor problem, replace the main control.
 - a. Unplug washer or disconnect power.
 - b. Replace the main control.
 - c. Reassemble all parts and panels.
 - d. Plug in washer or reconnect power. Calibrate washer and perform Automatic Test to verify repair.

⚠ WARNING



Electrical Shock Hazard
Disconnect power before servicing.
Replace all parts and panels before operating.
Failure to do so can result in death or electrical shock.

TEST #4: Console and Indicators

Console and Indicators Check:

This procedure checks the cycle selector knob, indicators, buttons, beeper, and if it exists—the 7-segment display.

1. Plug in washer or reconnect power.

TROUBLESHOOTING GUIDE (continued) FOR SERVICE TECHNICIANS ONLY

2. To access UI (User Interface) Test Mode, perform steps 1 and 2 of Activating the Service Diagnostic Modes. Turn the cycle selector knob until the display or status LED's correspond as follows:

- "Rinse & Spin" LED On, "06" Displayed on 7-segment

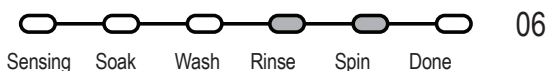

Press the START button to begin the UI test.

- Upon entering the UI test mode, all LED's and display (if it exists) will be turned ON.
- Pressing the POWER button will deactivate the UI test mode.
- Pressing the START button will toggle the display, start, and status indicators on and off.
- When rotating the cycle selector knob, each click "indent" toggles the "Done" LED as well as the associated cycle LED.
- Pressing each button will toggle its respective indicator(s) ON or OFF.

None of the indicators light up:

1. Unplug washer or disconnect power.
2. Access the console's electronic assemblies and visually check that the J9 connector is inserted all the way into the main control
3. Visually check that the user interface assembly is properly inserted in the console.
4. If both visual checks pass, follow procedure under TEST #1, "Main Control" to verify supply voltages.
 - If supply voltages are present on the main control, go to step 5.
 - If supply voltages are not present, replace the main control and calibrate washer (p. 4). Perform Automatic Test to verify repair. Go to step 6.
5. Replace the user interface assembly.
6. Reassemble all parts and panels.
7. Plug in washer or reconnect power.

8. Follow procedure under TEST #4, "Console and Indicators Check", to verify repair.

Some buttons do not light indicators:

1. Unplug washer or disconnect power.
2. Access the console's electronic assemblies and visually check that the electronics and housing assembly is properly inserted into the front console.
3. If visual check passes, replace the user interface assembly.
4. Reassemble all parts and panels.
5. Plug in washer or reconnect power.
6. Follow procedure under TEST #4, "Console and Indicators Check", to verify repair.

No beep sound is heard (HE models):

1. Verify that cycle signal is set to either "Soft" or "Loud." NOTE: Pressing and holding the cycle signal button for three seconds will Enable/Disable the cycle signal.
2. Unplug washer or disconnect power.
3. Access the console's electronic assemblies and visually check that the J9 connector is inserted all the way into the main control.
4. If visual check passes, replace the user interface assembly.
5. Plug in washer or reconnect power.
6. Set Cycle Signal to either "Soft" or "Loud." Check for beep tone.
7. If beeper still does not emit a tone, the main control has malfunctioned:
 - a. Unplug washer or disconnect power.
 - b. Replace the main control.
 - c. Reassemble all parts and panels.
 - d. Plug in washer or reconnect power. Calibrate washer and perform procedure under TEST #4, "Console and Indicators Check", to verify repair.

TROUBLESHOOTING GUIDE (continued) FOR SERVICE TECHNICIANS ONLY

WARNING



Electrical Shock Hazard

Disconnect power before servicing.

Replace all parts and panels before operating.

Failure to do so can result in death or electrical shock.

THERMISTOR RESISTANCE		
Approx. Temperature		Approx. Resistance
F°	C°	(KΩ)
32	0	163
41	5	127
50	10	100
59	15	79
68	20	62
77	25	50
86	30	40
95	35	33
104	40	27
113	45	22
122	50	18
131	55	15
140	60	12
149	65	10

TEST #5: Temperature Thermistor

This test checks valves, main control, temperature thermistor, and wiring.

1. Check the cold valve by performing Cold Valve test under Manual Test Mode.

If cold water is being dispensed, proceed to step 2.

- If hot water is being dispensed, verify proper hose connection.
2. Check the hot valve by performing Hot Valve test under Manual Test Mode.
 - If hot water is being dispensed, proceed to step 3.
 - If cold water is being dispensed, ensure that household hot water is present.
 3. Unplug washer or disconnect power.
 4. Remove console to access main control.
 5. Remove connector J3 from the main control. With an ohmmeter, measure the resistance of the temperature thermistor between pins J3-9 and J3-10. Verify that the approximate resistance, shown in the table (this page), is within ambient temperature range.

- If the resistance is within the range shown in the table, go to step 6.
- If the resistance is infinite or close to zero, replace the temperature thermistor assembly.

NOTE: Most thermistor errors are a result of the resistor being out of range. If the temperature thermistor malfunctions, the washer will default to pre-programmed wash settings.

6. If the thermistor is good, replace main control and calibrate washer. Perform Automatic Test to verify repair.

TEST #6: Water Level

This test checks the water level sensing components. **NOTE:** Usually, if the pressure transducer malfunctions, the washer will generate a long fill, or long drain error.

1. Check the functionality of the pressure transducer by running a small load cycle. The valves should turn off automatically after sensing the correct water level in the tub. The following steps assume that this step was unsuccessful.
2. Drain the tub until all water has been removed.
3. Unplug washer or disconnect power.

TROUBLESHOOTING GUIDE (continued) FOR SERVICE TECHNICIANS ONLY

4. Remove console to access main control.
5. Check hose connection between the pressure transducer on the main control and the pressure dome attached to the tub.
6. Check to ensure hose is routed correctly in the lower cabinet and not pinched or crimped by the back panel.
7. Verify there is no water, suds, or debris in the hose or dome. Disconnect hose from main control and blow into hose to clear water, suds, or debris.
8. Check hose for leaks. Replace if needed.
9. If the preceding steps did not correct the problem, replace main control and calibrate washer. Perform Automatic Test to verify repair.

The following steps assume that this step was unsuccessful.

3. Unplug washer or disconnect power.
4. Remove console to access main control.
5. Visually check that the J16 connector is inserted all the way into the main control.
 - If visual check passes, go to step 6.
 - If connector is not inserted properly, reconnect J16 and repeat step 2.

⚠ WARNING



Electrical Shock Hazard
Disconnect power before servicing.
Replace all parts and panels before operating.
Failure to do so can result in death or electrical shock.

TEST #7: Drain Pump

Perform the following checks if washer does not drain.

NOTE: Refer to Figure 6, “Drain Pump Strip Circuit” for tests and measurements.

IMPORTANT: Drain water from tub before accessing bottom of washer.

1. Check for obstructions in the usual areas. Clean and then perform step 2.
2. Check the drain pump and electrical connections by performing the Drain Test under Manual Test Mode.

TROUBLESHOOTING GUIDE (continued) FOR SERVICE TECHNICIANS ONLY

Console Electronics & Valves (Figure 7)

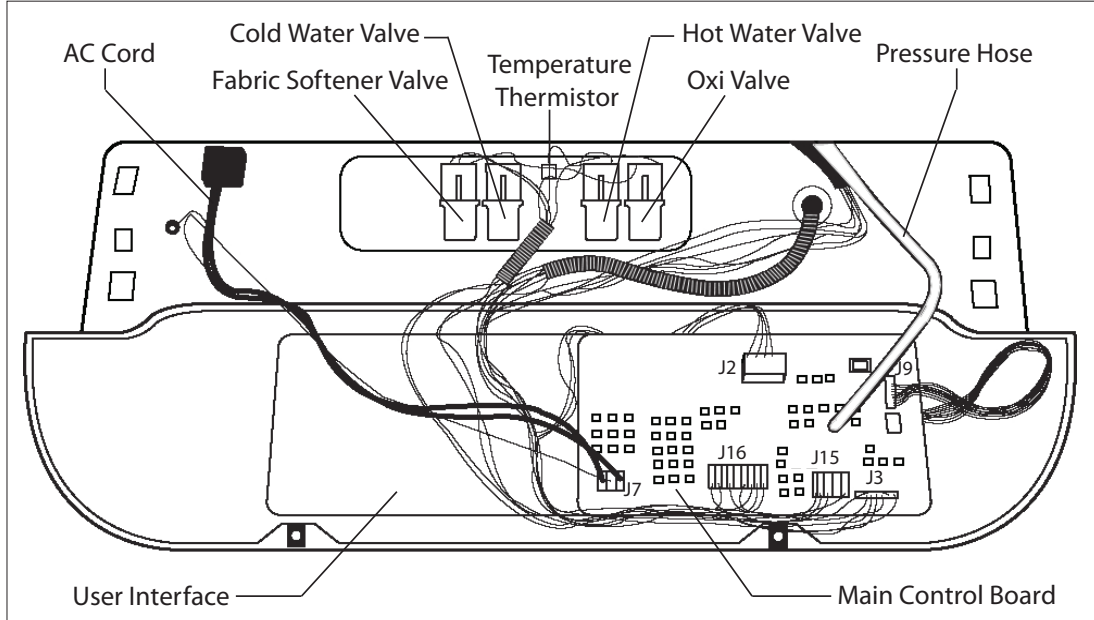

Drain Pump and Drive System (Figure 8)

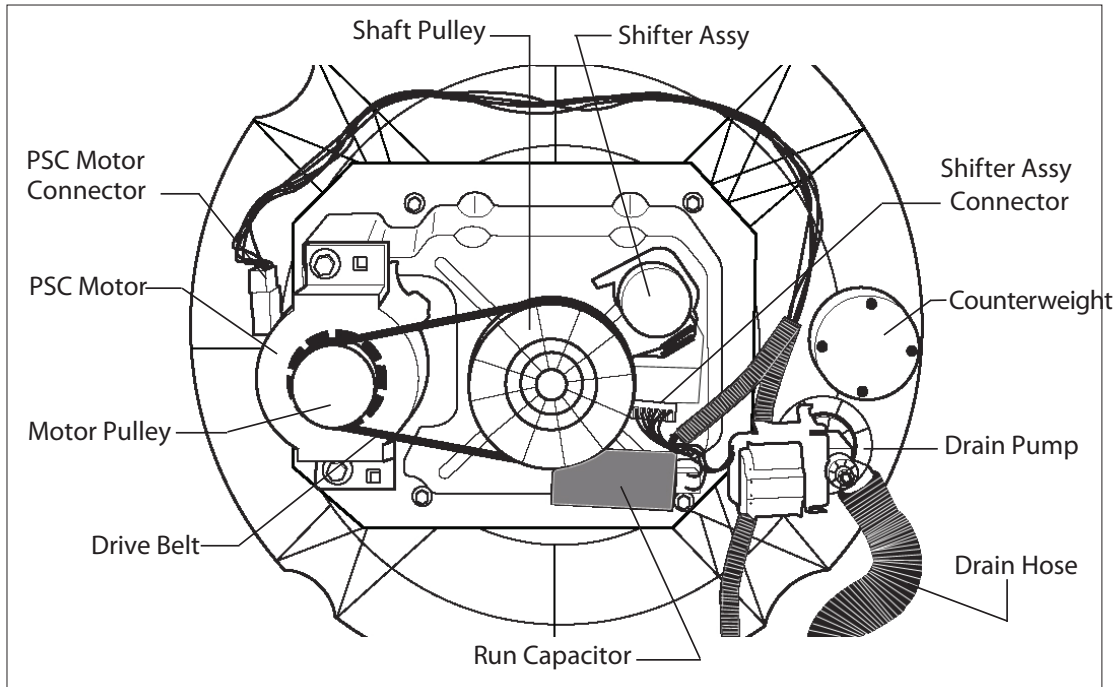

Specifications

WASHER SPECIFICATIONS	
Voltage:	90-140 VAC
Frequency:	57-63 HZ
Max. Amps:	12.0A
Circuit Protection:	15A Instantaneous Type Fuse (Main Control)
Water Pressure:	15-125 PSI
Drain Height:	34 in. to 8 ft. (86 cm to 244 cm)
Operating Temperature Range:	40 - 115° F (4.5 - 46° C)

WIRING DIAGRAM

Washer

IMPORTANT: Electrostatic discharge may cause damage to machine control electronics.

NOTE: Schematic shows shifter in SPIN position, lock switch open, and motor off.

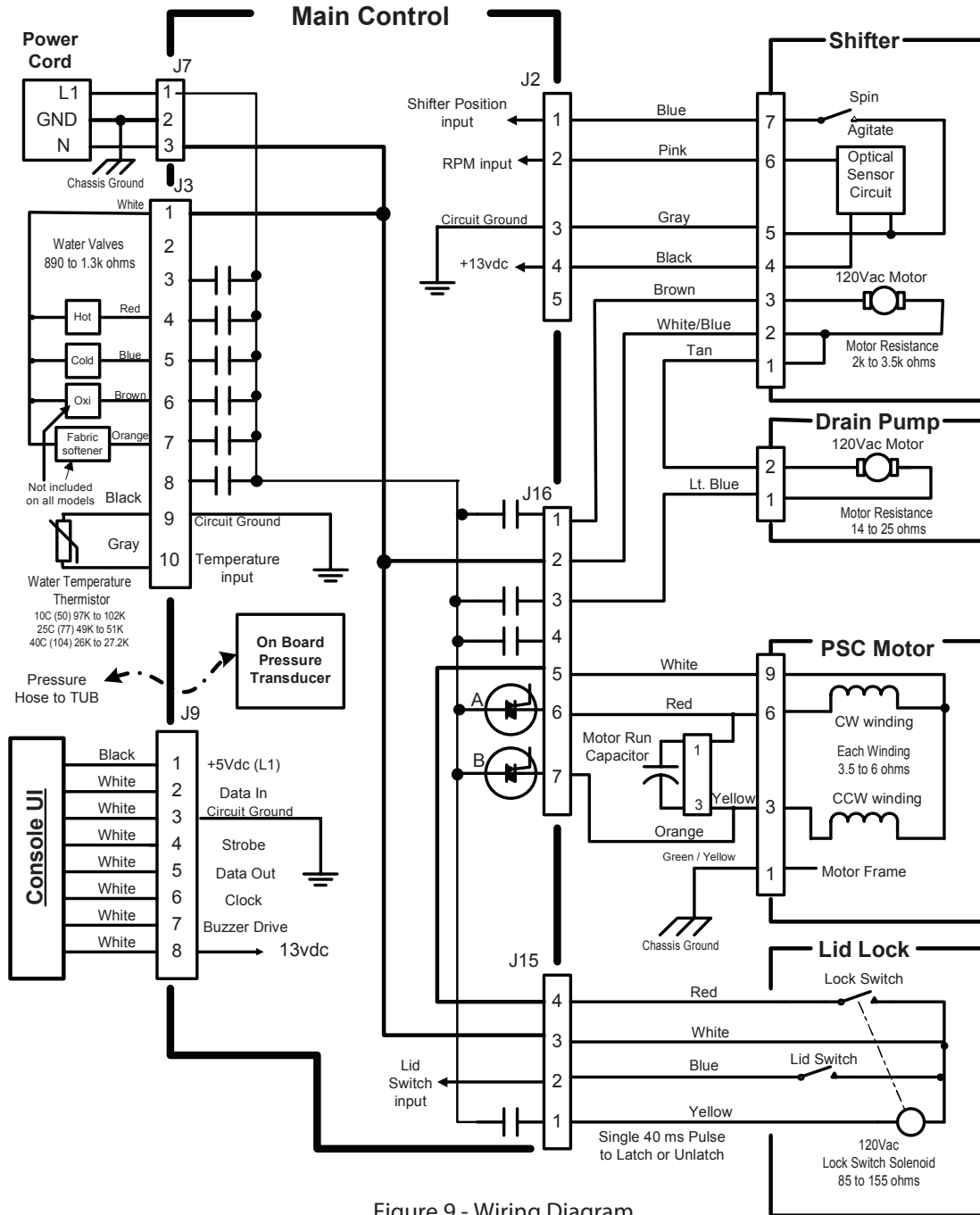

Figure 9 - Wiring Diagram

Legend

Component Terminals	Connection (Splice)	No Connection	Motor Triac	Relay	Switch	Thermistor	Circuit Ground	Chassis Ground

PRODUCT SPECIFICATIONS AND WARRANTY INFORMATION SOURCES

IN THE UNITED STATES:

FOR PRODUCT SPECIFICATIONS AND WARRANTY INFORMATION CALL:

FOR WHIRLPOOL PRODUCTS: 1-800-253-1301

FOR KITCHENAID PRODUCTS: 1-800-422-1230

FOR ROPER PRODUCTS: 1-800-447-6737

FOR TECHNICAL ASSISTANCE WHILE AT THE CUSTOMER'S HOME CALL:

THE TECHNICAL ASSISTANCE LINE: 1-800-832-7174

**HAVE YOUR STORE NUMBER READY TO IDENTIFY YOU AS AN
AUTHORIZED IN-HOME SERVICE PROFESSIONAL**

FOR LITERATURE ORDERS:

PHONE: 1-800-851-4605

FOR TECHNICAL INFORMATION AND SERVICE POINTERS:

www.servicematters.com

IN CANADA:

FOR PRODUCT SPECIFICATIONS AND WARRANTY INFORMATION CALL:

1-800-461-5681

FOR TECHNICAL ASSISTANCE WHILE AT THE CUSTOMER'S HOME CALL:

THE TECHNICAL ASSISTANCE LINE: 1-800-488-4791

**HAVE YOUR STORE NUMBER READY TO IDENTIFY YOU AS AN
AUTHORIZED IN-HOME SERVICE PROFESSIONAL**

