

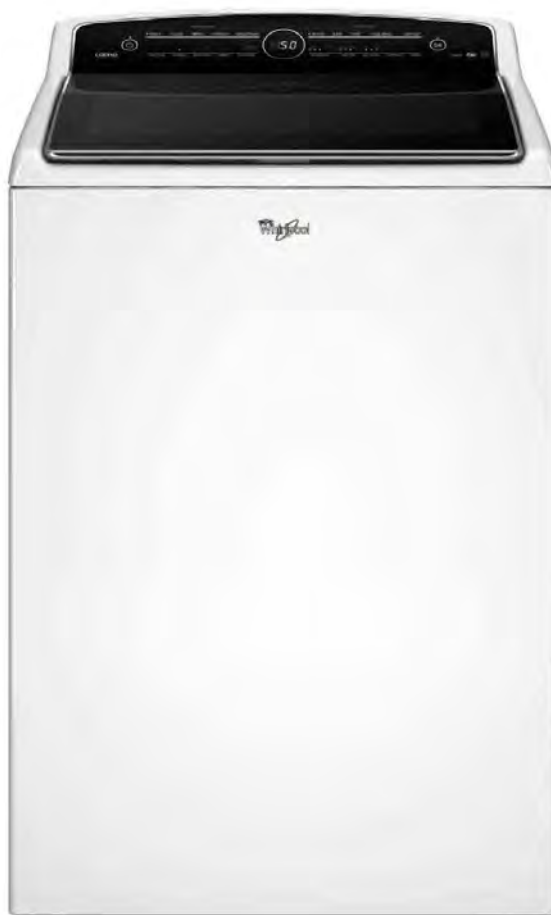

TECHNICAL EDUCATION

2014 CABRIO® TOP LOAD DIRECT DRIVE WASHER



WTW8500DW, WTW8500DC

FORWARD

This Whirlpool Job Aid, "2014 CABRIO® Top Load Direct Drive Washer" (Part No. W10758836), provides the In-Home Service Professional with information on the installation, operation, and service of the "2014 CABRIO® Top Load Direct Drive Washer." For specific operating information on the model being serviced, refer to the "Use and Care Guide" or "Tech Sheet" provided with the washer.

The Wiring Diagram used in this Job Aid is typical and should be used for training purposes only. Always use the Wiring Diagram supplied with the product when servicing the washer.

GOALS AND OBJECTIVES

The goal of this Job Aid is to provide information that will enable the In-Home Service Professional to properly diagnose malfunctions and repair the "2014 CABRIO® Top Load Direct Drive Washer."

The objectives of this Job Aid are to:

- Understand and follow proper safety precautions.
- Successfully troubleshoot and diagnose malfunctions.
- Successfully perform necessary repairs.
- Successfully return the washer to its proper operational status.

WHIRLPOOL CORPORATION assumes no responsibility for any repairs made on our products by anyone other than authorized In-Home Service Professionals.

TABLE OF CONTENTS

Whirlpool 2014 Top Load Direct Drive Washer

SECTION 1 — GENERAL INFORMATION

WASHER SAFETY	1-2
GENERAL THEORY OF OPERATION	1-3
MODEL & SERIAL NUMBER LABEL LOCATION	1-4
TECH SHEET LOCATION	1-4
MODEL AND SERIAL NUMBER NOMENCLATURE	1-5
PRODUCT SPECIFICATIONS	1-6

SECTION 2 — OPERATION

CONTROL PANEL AND FEATURES	2-2
DISPENSERS	2-3
CYCLE GUIDE	2-4
USING THE WASHER	2-5
WASHER MAINTENANCE	2-9
TROUBLESHOOTING	2-11
NOTES	2-16

SECTION 3 — INSTALLATION

INSTALLATION REQUIREMENTS	3-2
LOCATION REQUIREMENTS	3-2
DRAIN SYSTEM	3-3
ELECTRICAL REQUIREMENTS	3-4
INSTALLATION INSTRUCTIONS	3-4
CONNECT DRAIN HOSE	3-5
CONNECT INLET HOSES	3-6
LEVEL WASHER	3-7
COMPLETE INSTALLATION CHECKLIST	3-8
NOTES	3-8

SECTION 4 — COMPONENT ACCESS

COMPONENT LOCATIONS	4-2
REMOVING THE CONSOLE—METHOD A*	4-3
REMOVING THE CONSOLE—METHOD B*	4-4
REMOVING THE USER INTERFACE (UI)*	4-5
REMOVING THE WATER INLET VALVES*	4-6
REMOVING THE MAIN CONTROL*	4-7
REMOVING THE TUB RING, IMPELLER, AND BASKET*	4-8
REMOVING THE MOTOR AND DRIVE ASSEMBLY*	4-11
REMOVING THE PUMPS*	4-13
REMOVING THE HEATER*	4-14
REMOVING THE LID LOCK*	4-15
REMOVING THE LID AND A HINGE*	4-16

* Video Available  Look for this ICON throughout Section 4

SECTION 5 — DIAGNOSTICS & TROUBLESHOOTING

DIAGNOSTICS & TROUBLESHOOTING: SAFETY INFORMATION	5-2
DIAGNOSTIC GUIDE.....	5-3
DIAGNOSTIC LED - MAIN CONTROL	5-3
SELF DIAGNOSTIC MODE.....	5-3
ACTIVATING SERVICE DIAGNOSTIC MODE	5-3
KEY ACTIVATION & ENCODER TEST	5-4
SERVICE TEST MODE.....	5-4
LOAD AND TEST CYCLE FUNCTION NUMBERS CHART	5-5
SERVICE DIAGNOSTIC EXECUTION.....	5-6
SERVICE DIAGNOSTIC CHART.....	5-6
SOFTWARE VERSION DISPLAY.....	5-8
EXITING SERVICE DIAGNOSTIC MODE	5-8
FAULT/ERROR CODES.....	5-8
FAULT/ERROR CODES TABLE.....	5-9
TROUBLESHOOTING GUIDE	5-12
NOTES	5-16

SECTION 6 — TESTING

TESTING: SAFETY INFORMATION.....	6-2
COMPONENT LOCATIONS	6-3
WIRING DIAGRAM.....	6-4
COMPONENT TESTING	6-5
TEST #1: MAIN CONTROL.....	6-5
CONTROL BOARD / CONNECTORS & PINOUTS	6-6
TEST #2: VALVES.....	6-7
TEST #3: DRIVE SYSTEM	6-8
TEST #3A: DRIVE SYSTEM - SHIFTER.....	6-8
TEST #3B: DRIVE SYSTEM - MOTOR.....	6-10
TEST #4: KEYS AND ENCODERS.....	6-11
TEST #5: TEMPERATURE THERMISTOR	6-12
TEST #6: WATER LEVEL.....	6-13
TEST #7: DRAIN & RECIRCULATION PUMP	6-14
TEST #8: LID LOCK	6-15
TEST #9: HEATER ELEMENT.....	6-16

PRODUCT SPECIFICATIONS & WARRANTY INFORMATION SOURCES (inside back cover)

Section 1: General Information

This section provides general safety, parts, and information for the “Whirlpool 2014 CABRIO® Top Load Direct Drive Washer.”

- Washer Safety
- General Theory of Operation
- Model/Serial Number Location
- Tech Sheet Location
- Model & Serial Number Nomenclature
- Product Specifications

Washer Safety

Your safety and the safety of others are very important.

We have provided many important safety messages in this manual and on your appliance. Always read and obey all safety messages.



This is the safety alert symbol.

This symbol alerts you to potential hazards that can kill or hurt you and others.

All safety messages will follow the safety alert symbol and either the word "DANGER" or "WARNING."

These words mean:

⚠ DANGER

You can be killed or seriously injured if you don't immediately follow instructions.

⚠ WARNING

You can be killed or seriously injured if you don't follow instructions.

All safety messages will tell you what the potential hazard is, tell you how to reduce the chance of injury, and tell you what can happen if the instructions are not followed.

General Theory of Operation

INTRODUCTION

The new Cabrio® Top Load Washer represents industry-leading innovation with the new improved direct drive system. The previous direct drive washer operated using a floating basket to assist in the switching between spin and agitate modes.

The new washer operates with a clutch coil system that provides reliable, immediate, and smooth shifting between the various wash modes.

NEW COMPONENTS

The washer has the following new components:

Intuitive Touch Controls — the Cabrio® washer features a new capacitive touch console that first asks “what’s being washed” followed by “how you want to wash.” First select a cycle from the “What to Wash” (mixed, casuals, whites, delicates, and bulky sheets) and then select the “How to Wash” (normal, quick, cold, deep water, or color last). This new and improved input will help the customer achieve the best combination cycle available for the type of items being washed.



Figure 1 - Intuitive Touch Controls

Basket — the Cabrio® WTW8500D* washer has an extra large basket capacity of 5.3 cu.ft. Other than size, the major difference from the previous model is that this basket does not have a flotation chamber to assist with changing between spin and agitate modes.



Figure 2 - Basket

Motor — The motor is an electronically commutated direct-drive 3-phase BPM (Brushless Permanent Magnet) variable speed design that moves the impeller and spins the basket without the use of a transmission. The motor is comprised of a stator and rotor that are attached to the drive assembly. The motor direction and speed is controlled by the ACU (Appliance Control Unit) or main control, and is monitored by the rotor position sensor located on the stator.

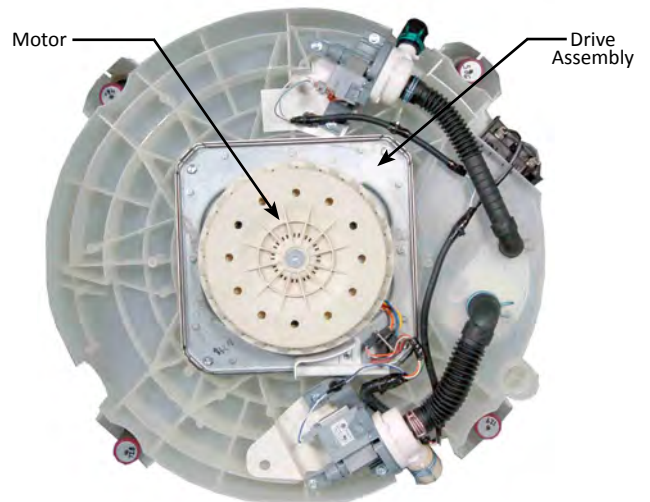

Figure 3 - Motor

...continued on next page

GENERAL INFORMATION

General Theory of Operation (continued)

NEW COMPONENTS

Clutch Coil and Clutch Assembly — the clutch coil on the washer is a simple electromagnetic coil, which when energized, pulls the clutch into contact with the rotor. The drive assembly contains an internal and external drive shaft. The internal shaft, which is connected directly to the rotor, agitates the impeller; whereas the external shaft, which is

directly connected to the clutch, is able to spin the basket. Therefore, when the clutch coil is energized, the resulting magnetic field pulls the clutch out to engage with the rotor, resulting in spinning both the basket and impeller together. When the coil is de-energized, the clutch disengages the rotor and the spring returns the clutch to its home position. The motor now controls only the impeller.

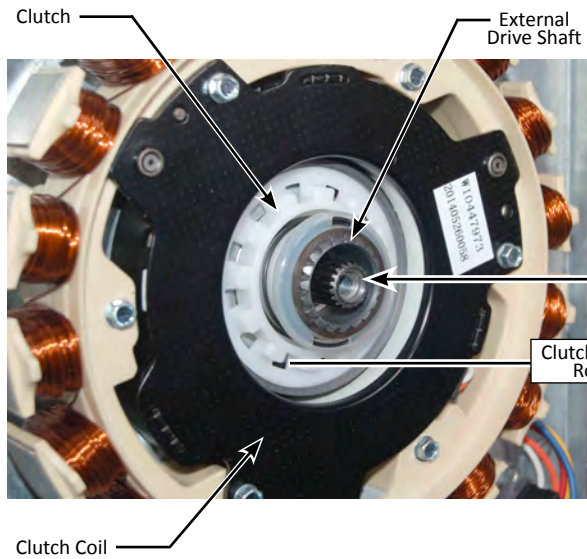

Figure 4 - Clutch Coil Assembly

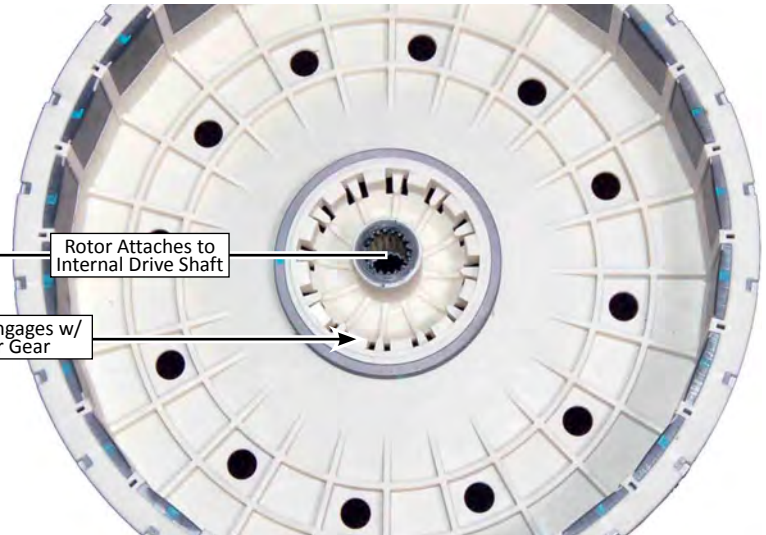

Figure 5 - Rotor

Model/Serial Number Label & Tech Sheet Location



Figure 6

Model & Serial Number Nomenclature

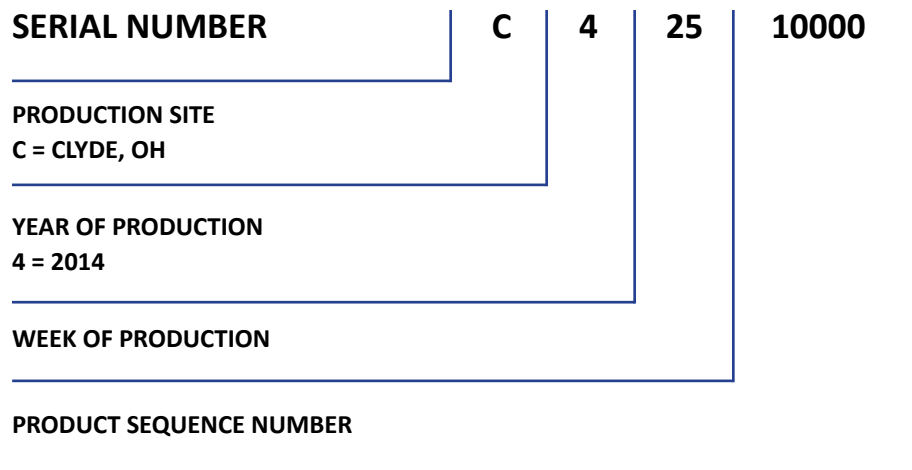
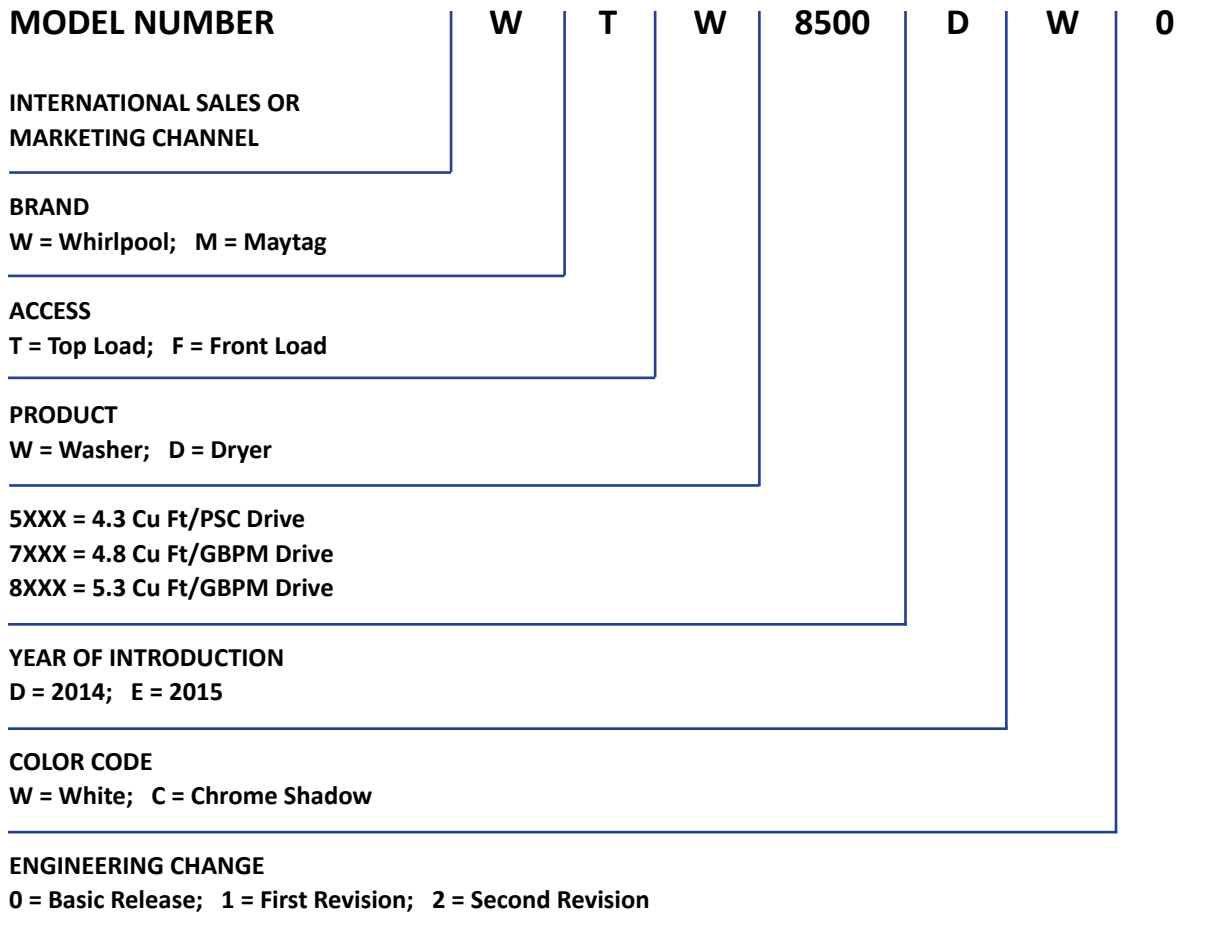

GENERAL INFORMATION

Product Specifications

ELECTRICAL	
Line Voltage :	120V AC
Frequency :	60 Hz
Amps :	10A
Low Volts Power Supply :	+12V, +5V
PRIMARY FEATURES	
Capacity :	5.3 cu. ft.
Control Panel :	Capacitive Touch/Electronic
Sound Package :	Quiet Wash™
Spin Speed (Max) :	850 RPM
Basket Material :	Stainless Steel
Wash Action :	Impeller
Window :	Yes
Energy Star® Qualified :	Yes
DISPENSERS	
HE Detergent :	Liquid or Powdered
Fabric Softener :	Liquid
Oxi :	Timed - 3/4 cup (180 mL)
Bleach :	Liquid 3/4 cup (180 mL)
WASH	
What to Wash :	Mixed, Casuals, Whites, Delicates, Bulky/Sheets
How to Wash :	Normal, Quick, Cold, Deep Water, ColorLast
Temperatures :	(5) Cold, Cool, Tap Cold, Warm, Hot
Soil Levels :	(4) Normal, Medium, Light, Heavy
OPTIONS	
Delay Start :	Up to 12 hours
Washer Options :	Steam Clean, Additives, Extra Rinse, PreSoak, Utility Tools
DIMENSIONS	
Height :	42-5/16" (107.47 cm)
Width :	27-1/2" (69.85 cm)
Depth :	27-15/16" (70.96 cm)
Gross Weight :	160 lbs. (72.57 kg)

Section 2: Operation

This section provides operational use and care information for the “Whirlpool 2014 CABRIO® Top Load Direct Drive Washer.”

- Control Panel and Features
- Dispensers
- Cycle Guide
- Using the Washer
- Washer Maintenance
- Troubleshooting
- Notes

Control Panel and Features

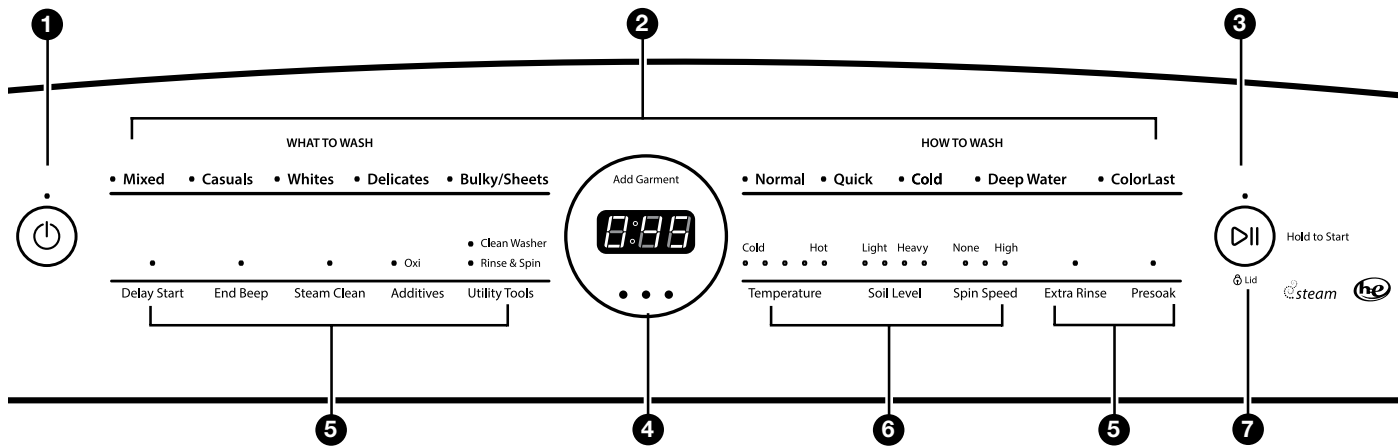

NOTE: The control panel features a sensitive surface that responds to a light touch of your finger. To ensure your selections are registered, touch the control panel with your finger tip, not your fingernail. When selecting a setting or option, simply touch its name until the desired section is illuminated.

1 POWER BUTTON

Touch to turn the washer ON. Touching once while the washer is on will cancel the current cycle and turn the washer OFF.

2 WHAT TO WASH/HOW TO WASH

First select a cycle from the “What to Wash” and then select the “How to Wash” to get the best combination cycle available for the type of items you are going to wash. See “Cycle Guide” for cycle details.

3 START/PAUSE BUTTON

Touch and hold START/PAUSE button for 3 seconds to begin the selected cycle; touch again to pause a cycle.

4 ADD GARMENT

When Add Garment is lit, you may pause the washer, open the lid, and add items. Touch and hold START to start the washer again.

TIME/STATUS DISPLAY

The Estimated Time Remaining display shows the time required for the cycle to complete. Factors such as load size and water pressure may affect the time shown in the display. Tightly packed loads, unbalanced loads, or excessive suds may cause the washer to adjust the cycle time, as well.

If you have set a delay start to the cycle, the Estimated Time Remaining display will show the delay time adjusted.

When the cycle is complete, the display will show END until the lid is opened.

5 OPTIONS

You may add or remove options for each cycle. Not all options can be used with all cycles, and some are preset to work with certain cycles.

DELAY START

Touch Delay Start to delay the start of the wash cycle up to 12 hours “12H”. Touch Delay Start until a “OH” appears in the status display to turn off, or touch POWER.

END BEEP

Use this to turn the signal indicating the end of a wash cycle to low, medium, high, or off.

NOTE: You may also turn off the tones that sound when a feature, setting, or option is touched. Touch and hold End Beep for about 3 seconds to turn key activation sounds on/off.

STEAM CLEAN

The Steam Clean option adds additional soak and wash time to many cycles to help remove tough stains, as well as a steam boost for added cleaning power. Steam Clean uses a heater within the washer to maintain the selected temperature setting throughout the wash period. Steam Clean may be selected as an option with other cycles.

ADDITIVES - OXI

Select the Oxi option so that it is added to the load at the correct time.

UTILITY TOOLS

Clean Washer

Use this every 30 washes to keep the inside of your washer fresh and clean. This cycle uses a higher water level. Use with affresh® Washer Cleaner tablet or liquid chlorine bleach to thoroughly clean the inside of your washer. This cycle should not be interrupted. Also optimizes load sensing for optimal wash performance. See “Washer Care.”

IMPORTANT: Do not place garments or other items in the washer during the Clean Washer cycle. Use this cycle with an empty wash tub.

Rinse & Spin

Combines a rinse and high speed spin for loads requiring an additional rinse cycle. Also use for loads that require rinsing only. If you want Drain & Spin select Rinse & Spin and then deslect Extra Rinse.

EXTRA RINSE

This option can be used to automatically add a second rinse to most cycles.

PRESOAK

Use this option to add an extra soak period to any cycle to help loosen tough stains. The washer will fill and then pause to soak, and then begin the selected cycle.

Control Panel and Features

6 CYCLE MODIFIERS

When you select a cycle, its default settings or the previous cycle selection used will light up.

TEMPERATURE

Temperature control senses and maintains uniform water temperatures by regulating incoming hot and cold water.

Select a wash temperature based on the type of fabric and soils being washed. For best results and following the garment label instructions, use the warmest wash water safe for your fabric.

- On some models and cycles, warm and hot water may be cooler than your previous washer.
- Even for cold wash settings, some warm water may be added to the washer to maintain a minimum temperature.

SOIL LEVEL

Soil Level (wash time) is preset for each wash cycle. As you touch the Soil Level pad, the cycle time (minutes) will increase or decrease in the Estimated Time Remaining display and a different wash time will appear.

Select the most suitable setting for your load. For heavily soiled items, select Heavy Soil Level for more wash time. For lightly soiled items, select Light Soil Level for less wash time. Lighter soil level setting will help reduce tangling and wrinkling.

SPIN SPEED

This washer automatically selects the spin speed based on the cycle selected. The preset speeds can be changed. Not all spin speeds are available with all cycles.

- Faster spin speeds mean shorter dry times, but may increase wrinkling in your load.
- Slower spin speeds mean less wrinkling, but will leave your load more damp.

7 LID

The Lid Lock (🔒 Lid) indicator lights up when the lid is locked and cannot be opened. If you need to open the lid, touch START/PAUSE. The lid will unlock once the washer movement has stopped. This may take several minutes if the load was spinning at high speed. Touch and hold START/PAUSE button again for 3 seconds to restart the cycle.

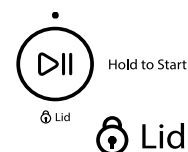

Dispensers

A Liquid fabric softener dispenser

Pour measured liquid fabric softener into the liquid fabric softener dispenser, if desired. It will dispense automatically at the optimum time.

- Use only liquid fabric softener in this dispenser.

B High Efficiency "HE" detergent dispenser

Add liquid or powdered HE detergent product to this dispenser for your main wash cycle. Remove tray if using powder detergent.

IMPORTANT: Make sure tray is in drawer when using liquid detergent and removed when using powder detergent and do not go over the Max line.



Use only High Efficiency (HE) detergent.

C TimedOxi dispenser

This dispenser holds up to 3/4 cup (180 mL) Oxi booster or other laundry booster, such as powdered or liquid color-safe bleach. Laundry boosters are automatically dispensed at the proper time during the wash cycle. Be sure to select Oxi from the options to ensure proper dispensing.

NOTE: Fill dispenser with only oxi. Do not mix with bleach.

D Liquid chlorine bleach dispenser

The bleach will be automatically diluted and dispensed at the optimum time during the wash cycle. This dispenser cannot dilute powdered bleach.

NOTE: Fill dispenser with only liquid bleach.

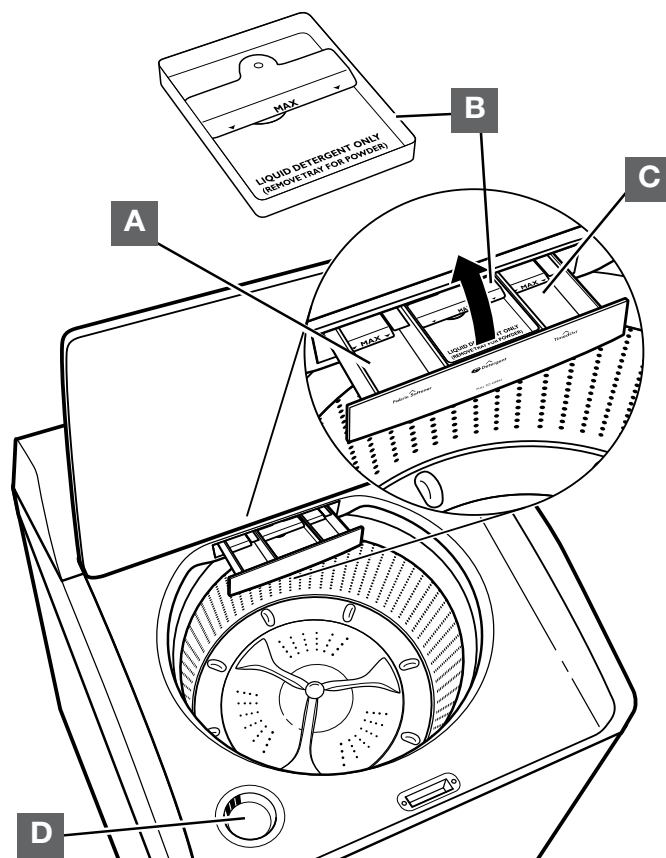

Cycle Guide

The Whirlpool® Cabrio® washer, has a unique user interface to help you select the best cycle you need for your load. The “What to Wash” “How to Wash” layout guides you to the optimal cycle in two easy steps:

First determine what items are in the load that you are trying to wash. Use that to guide your “What to Wash” selection. Then determine how you want the washer to wash them and select the appropriate “How to Wash” selection. See chart below for more details.

For best fabric care, choose the cycle that best fits the load being washed.

R - Recommended Cycle

a - Alternate Cycle

Blank – Cycle is available but not optimal.

		How do you want to wash?				
		“How to Wash” Cycle Selection				
		Normal	Quick	Cold	Deep Water	ColorLast
		• <i>Powerful Soil Removal</i> • <i>Regular</i>	• <i>Fast</i>	• <i>Saving Water & Energy</i> • <i>Cold Wash</i>	• <i>with Extra Water</i> • <i>“Conventional Style” More Water</i>	• <i>Protecting my colors</i> • <i>Protecting my fabrics</i> • <i>Gentle cleaning</i>
What do you want to wash?	“What to Wash” Cycle Selection					
Athletic/High Performance Wear	Mixed	R	a	a	a	a
Bright Colors				a		R
Cottons/Linens		R				
Dark Colors				a		R
Jeans		R	a	a	a	
Pajamas		R	a	a	a	a
Sweatshirts		R	a	a	a	a
Terry Cloth		R	a		a	
Towels		R	a		a	
T-Shirts		R	a	a	a	a
Business Casual		Casuals	R	a	a	a
Dress Shirts/Pants	R		a	a	a	a
Linens	R		a	a	a	a
No-Iron Fabrics	R		a	a	a	a
Baby Clothes	Whites	R			a	NA
Dish Cloths		R	a		a	
Handkerchiefs		R	a		a	
Napkins		R	a		a	
Socks		R	a		a	
Tablecloth		R	a	a	a	
Undergarments		R	a		a	
White Clothing		R	a	a	a	
White Shirts		R	a	a	a	
White Towels		R	a		a	
White T-Shirts		R	a	a	a	
Bras	Delicates	R	a	a	a	a
Handwash Fabrics		R	a	a	a	a
Lingerie		R	a	a	a	a
Machine Wash Silks		R	a	a	a	a
Wool		R	a	a	a	a
Blankets	Bulky/Sheets	a	a	a	R	
Coats & Jackets		R	a	a	a	a
Comforters		a	a	a	R	
Machine Wash Curtains		R	a	a	a	a
Machine Wash Slip Covers		R	a	a	a	
Non-Rubber Lined Rugs & Mats		R	a	a	a	
Sheets		R	a		a	a
Sleeping Bags		a	a	a	R	

Using the Washer

⚠ WARNING



Fire Hazard

Never place items in the washer that are dampened with gasoline or other flammable fluids.

No washer can completely remove oil.

Do not dry anything that has ever had any type of oil on it (including cooking oils).

Doing so can result in death, explosion, or fire.

⚠ WARNING



Electrical Shock Hazard

Plug into a grounded 3 prong outlet.

Do not remove ground prong.

Do not use an adapter.

Do not use an extension cord.

Failure to follow these instructions can result in death, fire, or electrical shock.

1. Sort and prepare your laundry

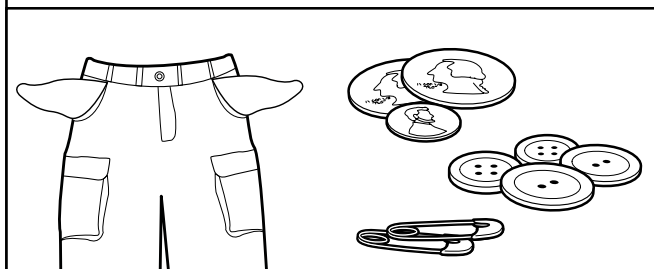

- Empty pockets. Loose change, buttons, or any small object can pass under the washplate and become trapped, causing unexpected sounds.
- Sort items by recommended cycle, water temperature, and colorfastness.
- Separate heavily soiled items from lightly soiled.
- Separate delicate items from sturdy fabrics.
- Do not dry items if stains remain after washing; heat can set stains into fabric.
- Treat stains promptly.
- Close zippers, fasten hooks, tie strings and sashes. Remove non-washable trim and ornaments.
- Mend rips and tears to avoid further damage to items during washing.

Helpful Tips:

- For best performance, use HE liquid detergent when washing bulky items.
- When washing water-proof or water-resistant items, load evenly.
- Use mesh bags to help avoid tangling when washing delicate or small items.
- Turn knits inside out to avoid pilling. Separate lint-takers from lint-givers. Synthetics, knits, and corduroy fabrics will pick up lint from towels, rugs, and chenille fabrics.

NOTE: Always read and follow fabric care labels instructions to avoid damage to your items.

2. Add laundry products

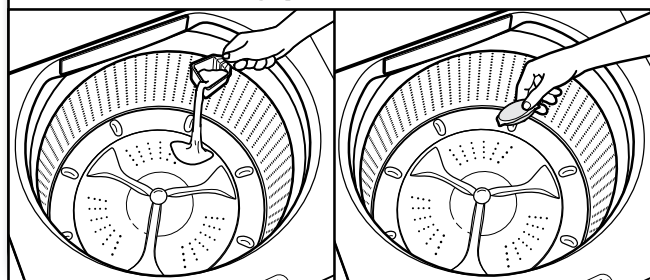

Single-dose laundry packet, color-safe bleach, or fabric softener crystals can be added to the basket prior to adding laundry.

NOTE: Always follow manufacturer's instructions.

3. Load laundry into washer

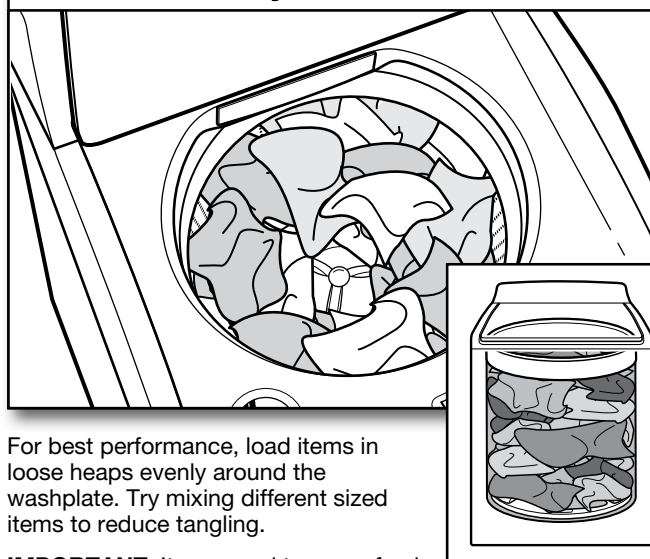

For best performance, load items in loose heaps evenly around the washplate. Try mixing different sized items to reduce tangling.

IMPORTANT: Items need to move freely for best cleaning and to reduce wrinkling and tangling.

Using the Washer (continued)

Using Laundry Product Dispensers

NOTE: Do not add single-dose laundry packets, color-safe bleach, or fabric softener crystals to dispensers. They will not dispense correctly. Add to the basket prior to adding laundry.

4. Add HE detergent

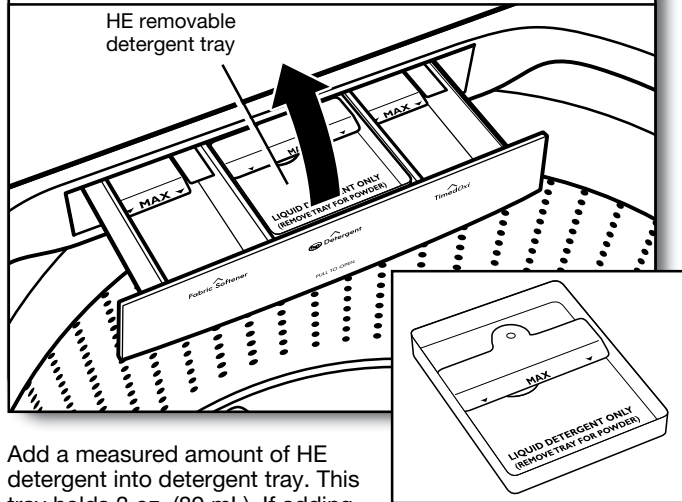

Add a measured amount of HE detergent into detergent tray. This tray holds 3 oz. (89 mL). If adding powder HE detergent remove inside tray. Do not overfill tray - adding too much detergent may cause detergent to be dispensed into the washer too early.

NOTE: Make sure tray is in drawer when using liquid detergent and removed when using powder detergent and do not go over the Max line.

IMPORTANT: Use only High Efficiency detergents. The package will be marked "HE" or "High Efficiency." Low-water washing creates excessive sudsing with a regular non-HE detergent. Using regular detergent will likely result in longer cycle times and reduced rinsing performance. It may also result in component failures and noticeable mold or mildew. HE detergents are made to produce the right amount of suds for the best performance. Follow the manufacturer's instructions to determine the amount of detergent to use.

HELPFUL TIP: See "Washer Maintenance" for information on recommended method of cleaning washer dispenser trays.

5. Add liquid chlorine bleach to dispenser

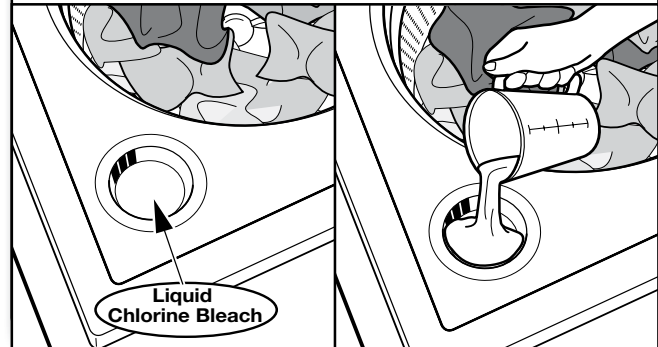

Do not overfill, dilute, or use more than 1 cup (236 mL). Do not use color-safe bleach or Oxi products in the same cycle with liquid chlorine bleach.

6. Add liquid fabric softener or Oxi to dispenser

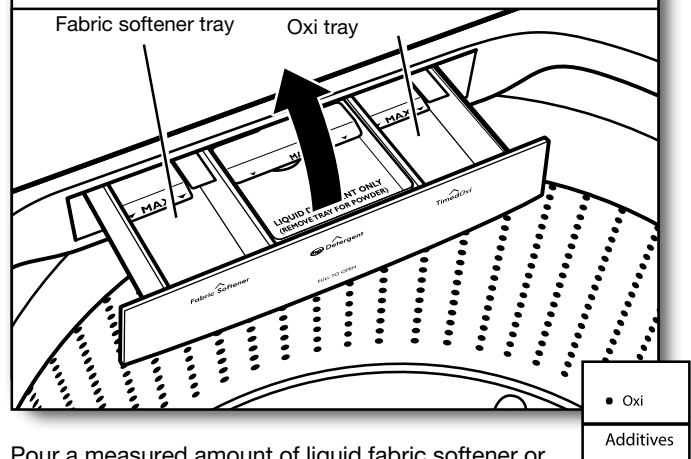

Pour a measured amount of liquid fabric softener or Oxi-type boosters, into tray; always follow manufacturer's directions for correct amount of fabric softener or Oxi based on your load size. Close dispenser drawer, then select Oxi option. Oxi is added during main wash and Fabric Softener is added during rinse.

IMPORTANT: Oxi option must be selected to ensure proper distribution at correct time in cycle. Do not overfill or dilute. Overfilling dispenser will cause fabric softener to immediately dispense into washer.

If Extra Rinse option is selected, fabric softener will be dispensed into the last rinse.

It is normal for a small amount of water to remain in the dispenser at the end of a cycle.

Using the Washer (continued)

7. Touch POWER to turn on washer

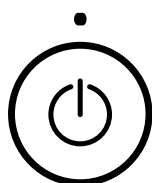

Make sure the dispenser drawer is closed completely, then touch POWER to turn on the washer.

8. Select the type of load to wash

WHAT TO WASH

- Mixed
- Casuals
- Whites
- Delicates
- Bulky/Sheets

HOW TO WASH

- Normal
- Quick
- Cold
- Deep Water
- ColorLast

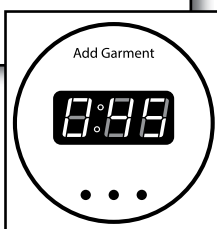

First touch a cycle from the “What to Wash” and then select the “How to Wash” to get the best combination cycle available for the type of items you are going to wash. See “Cycle Guide” for cycle details. Red, green, and blue LED lights come on below the time/status display when the “How to Wash” ColorLast cycle is selected. Not all cycles are available on all models.

Estimated Time Remaining will light up with a cycle time. You may notice time adjusting during the cycle. This is normal.

If you do not want to begin a cycle immediately, you may choose DELAY START option.

To choose a delay time:

1. Touch DELAY START button to select desired delay time. Time will increase in hour increments up to 12 hours.
2. Touch and hold START/PAUSE button for 3 seconds to start delay start time.

IMPORTANT: When delaying a cycle, use liquid HE detergent only in the dispenser. Powdered detergents may absorb moisture from a previous cycle and clump before the wash cycle begins.

To cancel delay start:

1. Touch POWER to cancel Delay Start.

To pause delay start:

1. Touch START/PAUSE button to pause delay start.
2. Touch and hold START/PAUSE button again to start Delay Start time.

9. Select cycle modifiers

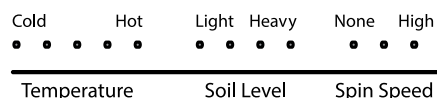

Once you select a cycle, the default modifiers or the previous set modifiers for that cycle will be lit. Touch the cycle settings buttons to change the Soil Level, Spin Speed, and Temperature, if desired. Not all settings are available with all cycles.

NOTE: Always read and follow fabric care labels instructions to avoid damage to your items. If not sure on which temperature to use, refer to the chart below or select a cooler temperature.

Temperature suggestions

Cold

Hot

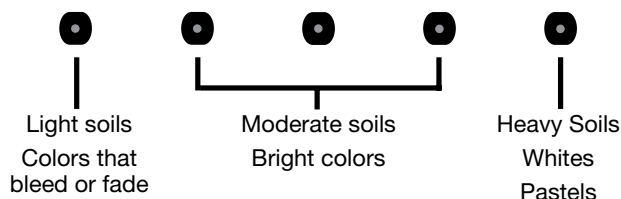

NOTE: Even for cold wash settings, some warm water may be added to the washer to maintain a minimum temperature.

Using the Washer (continued)

10. Select cycle options

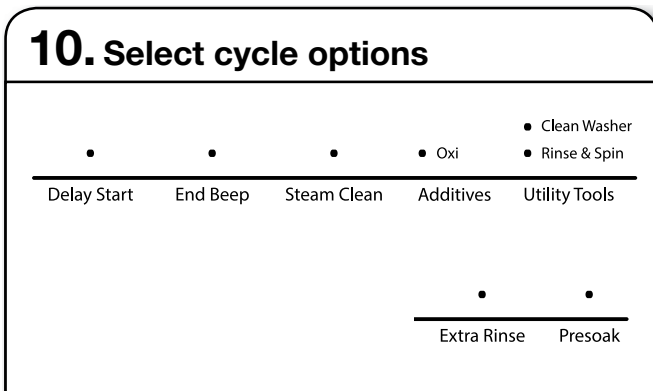

Select any other cycle options you may wish to add, if not previously set. Some cycles will automatically add certain options such as Extra Rinse. These may be turned off, if desired.

NOTE: Not all options are available with all cycles. Touch control panel to select any other options.

11. Touch and hold START/PAUSE button to begin wash cycle



Touch and hold START/PAUSE button for 3 seconds to start the wash cycle. When the cycle has finished, the end of cycle signal will sound (if set). Promptly remove items when cycle is done to avoid odor, reduce wrinkling, and rusting of metal hooks, zippers, and snaps.

Unlocking the lid to add items

If you need to open the lid to add 1 or 2 missed items:

Touch START/PAUSE button to pause washer; the lid will unlock once the washer movement has stopped. This may take several minutes if the load was spinning at a high speed. Then close lid and touch and hold START/PAUSE button again for 3 seconds to restart the cycle.

IMPORTANT: If lid is left open for more than 10 minutes the water will pump out and F8E6 error code will appear on the display.

Washer Maintenance

WATER INLET HOSES

Replace inlet hoses after 5 years of use to reduce the risk of hose failure. Periodically inspect and replace inlet hoses if bulges, kinks, cuts, wear, or leaks are found.

When replacing your inlet hoses, mark the date of replacement on the label with a permanent marker.

NOTE: This washer does not include inlet hoses. See the Installation Instructions for more information.

WASHER CARE

Recommendations to Help Keep Your Washer Clean and Performing at its Best

1. Always use High Efficiency (HE) detergents and follow the HE detergent manufacturer's instructions regarding the amount of HE detergent to use. Never use more than the recommended amount because that may increase the rate at which detergent and soil residue accumulate inside your washer, which in turn may result in undesirable odor.
2. Use warm and hot wash water settings sometimes (not exclusively cold water washes), because they do a better job of controlling the rate at which soils and detergent accumulate.
3. Always leave the washer lid open between uses to help dry out the washer and prevent the buildup of odor-causing residue.

Cleaning Your Top Loading Washer

Read these instructions completely before beginning the routine cleaning processes recommended below. This Washer Maintenance Procedure should be performed, at a minimum, once per month or every 30 wash cycles, whichever occurs sooner, to control the rate at which soils and detergent may otherwise accumulate in your washer.

Cleaning the Inside of the Washer

To keep your washer odor-free, follow the usage instructions provided above, and use this recommended monthly cleaning procedure:

Clean Washer Cycle

This washer has a special cycle that uses higher water volumes in combination with affresh® Washer Cleaner or liquid chlorine bleach to clean the inside of the washer.

Begin procedure

1. **affresh® Washer Cleaner Cycle Procedure (Recommended for Best Performance):**
 - a. Open the washer lid and remove any clothing or items.
 - b. Place an affresh® Washer Cleaner tablet in the bottom of the washer basket.
 - c. Do not place an affresh® Washer Cleaner tablet in the detergent dispenser.
 - d. Do not add any detergent or other chemical to the washer when following this procedure.
 - e. Close the washer lid.
 - f. Select the CLEAN WASHER cycle.
 - g. Touch and hold the START/PAUSE button for 3 seconds to begin the cycle. The Clean Washer Cycle Operation is described below.

NOTE: For best results, do not interrupt cycle. If cycle must be interrupted, touch POWER. After the Clean Washer cycle has stopped, run a Rinse & Spin cycle to rinse cleaner from washer.

WASHER CARE (cont.)

2. Chlorine Bleach Procedure (Alternative):

- a. Open the washer lid and remove any clothing or items.
- b. Add 1 cup (236 mL) of liquid chlorine bleach to the bleach compartment.

NOTE: Use of more liquid chlorine bleach than is recommended above could cause washer damage over time.

- c. Close the washer lid.
- d. Do not add any detergent or other chemical to the washer when following this procedure.
- e. Select the CLEAN WASHER cycle.
- f. Touch and hold the START/PAUSE button for 3 seconds to begin the cycle. The Clean Washer Cycle Operation is described below.

NOTE: For best results, do not interrupt cycle. If cycle must be interrupted, touch POWER. After the Clean Washer cycle has stopped, run a Rinse & Spin cycle to rinse cleaner from washer.

Description of Clean Washer Cycle Operation:

1. This cycle will fill to a water level higher than in normal wash cycles to provide rinsing at a level above the water line for normal wash cycle.
2. During this cycle, there will be some agitation and spinning to increase the removal of soils.

After this cycle is complete, leave the lid open to allow for better ventilation and drying of the washer interior.

Cleaning the Outside of the Washer

Use a soft, damp cloth or sponge to wipe away any spills. Use only mild soaps or cleaners when cleaning external washer surfaces.

IMPORTANT: To avoid damaging the washer's finish, do not use abrasive products.

Washer Maintenance (continued)

NON-USE AND VACATION CARE

Operate your washer only when you are home. If moving, or not using your washer for a period of time, follow these steps:

1. Unplug or disconnect power to washer.
2. Turn off water supply to washer, to avoid flooding due to water pressure surge.

CLEANING YOUR DISPENSER

You may find laundry product residue leftover in your dispenser drawer. To remove residue, follow this recommended cleaning procedure:

1. Pull drawer out until you feel resistance.
2. Push 2 tabs downward, and then continue pulling out.
3. Wash in warm, soapy water, using a mild detergent.
4. Rinse with warm water.
5. Air dry, or dry with a towel.
6. Then replace drawer back into slot. Make sure drawer is properly seated.

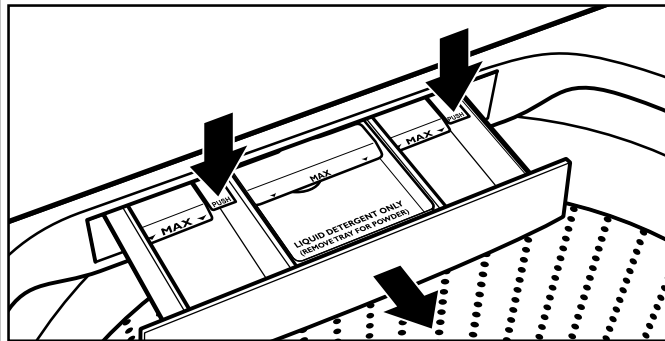

IMPORTANT: Dispenser drawer and tray are not dishwasher safe.

WINTER STORAGE CARE

IMPORTANT: To avoid damage, install and store washer where it will not freeze. Because some water may stay in hoses, freezing can damage washer. If storing or moving during freezing weather, winterize your washer.

To winterize washer:

1. Shut off both water faucets; disconnect and drain water inlet hoses.
2. Put 1 qt. (1 L) of R.V.-type antifreeze in basket and run washer on RINSE & SPIN cycle for about 30 seconds to mix antifreeze and remaining water.
3. Unplug washer or disconnect power.

TRANSPORTING YOUR WASHER

1. Shut off both water faucets. Disconnect and drain water inlet hoses.
2. If washer will be moved during freezing weather, follow WINTER STORAGE CARE directions before moving.
3. Disconnect drain from drain system.
4. Unplug power cord.
5. Place inlet hoses inside washer basket.
6. Drape power cord and drain hose over the console and secure with masking tape.
7. Place foam packing ring from original shipping materials back inside washer. If you do not have packing ring, place heavy blankets or towels into basket opening. Close lid and place tape over lid and down front of washer. Keep lid taped until washer is placed in new location. Transport washer in the upright position.

⚠ WARNING



Electrical Shock Hazard

Plug into a grounded 3 prong outlet.

Do not remove ground prong.

Do not use an adapter.

Do not use an extension cord.

Failure to follow these instructions can result in death, fire, or electrical shock.

REINSTALLING/USING WASHER AGAIN

To reinstall washer after non-use, vacation, winter storage or moving:

1. Refer to Installation Instructions to locate, level, and connect washer.
2. Before using again, run washer through the following recommended procedure:

To use washer again:

1. Flush water pipes and hoses. Reconnect water inlet hoses. Turn on both water faucets.
2. Plug in washer or reconnect power.
3. Run washer through Bulky/Sheets and Deep Water Wash cycle to clean washer and remove antifreeze, if used. Use only HE High Efficiency detergent. Use half the manufacturer's recommended amount for a medium-size load.

Troubleshooting

First try the solutions suggested here or visit our website at www.whirlpool.com/product_help -
In Canada www.whirlpool.ca for assistance and to possibly avoid a service call.

If you experience	Possible Causes	Solution
Vibration or Off-Balance		
Vibration, rocking, or "walking"	Feet may not be in contact with the floor and locked.	Front and rear feet must be in firm contact with floor, and washer must be level to operate properly.
	Washer may not be level.	Check floor for flexing or sagging. If flooring is uneven, a 3/4" (19 mm) piece of plywood under your washer will reduce sound. See "Level the Washer" in the Installation Instructions.
Vibration during spinning or washer stopped	Load could be unbalanced.	Load items in loose heaps evenly around the washplate. Adding wet items to washer or adding more water to basket could unbalance washer.
		Avoid washing single items. Balance a single item such as a rug or jeans jacket with a few extra items. Redistribute the load, close the lid, and touch and hold START/PAUSE.
		Use Bulky/Sheets Deep Water Wash cycle for oversized, non-absorbent items such as comforters or poly-filled jackets. Other items are not appropriate for Bulky/Sheets Normal cycle. See "Cycle Guide."
		Item or load not suitable for selected cycle. See "Cycle Guide" and "Using Your Washer."
Noises – For normal operating sounds, go to www.whirlpool.com/product_help.		
Clicking or metallic noises	Objects may be caught in washer drain system.	Empty pockets before washing. Loose items such as coins could fall between basket and tub or may block pump. It may be necessary to call for service to remove items.
		It is normal to hear metal items on clothing such as metal snaps, buckles, or zippers touch against the stainless steel basket.
Gurgling or humming	Washer may be draining water.	It is normal to hear the pump making a continuous humming sound with periodic gurgling or surging as final amounts of water are removed during the spin/drain cycles.
Humming	Load sensing may be occurring.	You may hear the hum of the sensing spins after you have started the washer. This is normal.
Whirring	Basket may be slowing down.	You may hear the whirring sound of the basket slowing down. This is normal.
Water Leaks		
Check the following for proper installation:	Washer not level.	Water may splash off basket if washer is not level.
	Fill hoses not attached tightly.	Tighten fill-hose connection.
	Fill hose washers	Make sure all four fill hose flat washers are properly seated.
	Drain hose connection	Pull drain hose from washer cabinet and properly secure it to drainpipe or laundry tub.
		Do not place tape over drain opening.
	Check household plumbing for leaks or clogged sink or drain.	Water can back up out of a clogged sink or drainpipe. Check all household plumbing for leaks (laundry tubs, drain pipe, water pipes, and faucets.)
Washer not loaded as recommended.	An unbalanced load can cause basket to be out of alignment and cause water to splash off tub. See "Using Your Washer" for loading instructions.	
Washer not performing as expected		
Not enough water in washer	Load not completely covered in water.	This is normal operation for an HE low-water washer. The load will not be completely underwater. The washer senses load sizes and adds correct amount of water for optimal cleaning. See "What's New under the Lid."
		IMPORTANT: Do not add more water to washer. Adding water lifts the items off the washplate, resulting in less effective cleaning. Run clean washer cycle to optimize the water level and wash performance.

Troubleshooting (continued)

First try the solutions suggested here or visit our website at www.whirlpool.com/product_help -
In Canada www.whirlpool.ca for assistance and to possibly avoid a service call.

If you experience	Possible Causes	Solution
Washer not performing as expected		
Washer won't run or fill, washer stops working	Check for proper water supply.	Both hoses must be attached and have water flowing to inlet valve.
		Both hot and cold water faucets must be turned on.
		Check that inlet valve screens have not become clogged.
		Check for any kinks in inlet hoses, which can restrict water flow.

WARNING



Electrical Shock Hazard

Plug into a grounded 3 prong outlet.

Do not remove ground prong.

Do not use an adapter.

Do not use an extension cord.

Failure to follow these instructions can result in death, fire, or electrical shock.

Washer won't run or fill, washer stops working (cont.)	Check proper electrical supply.	Plug power cord into a grounded 3-prong outlet.
		Do not use an extension cord.
		Ensure there is power to outlet.
		Reset a tripped circuit breaker. Replace any blown fuses. NOTE: If problems continue, contact an electrician.
	Normal washer operation.	Lid must be closed for washer to run.
		Washer will pause during certain phases of cycle. Do not interrupt cycle.
		Washer may be stopped to reduce suds.
	Washer may be tightly packed.	Remove several items, rearrange load evenly around the washplate. Close lid, touch and hold START/PAUSE button.
		Add only 1 or 2 additional items after washer has started.
		Do not add more water to the washer.
	Not using HE detergent or using too much HE detergent.	Only use HE detergent. Suds from regular detergents can slow or stop the washer. Always measure detergent and following detergent directions based on your load requirements.
		To remove suds, cancel cycle. Select RINSE & SPIN. Touch and hold START/PAUSE button. Do not add more detergent.
Washer not draining/spinning, loads are still wet	Small items may have been caught in pump or between basket and tub, which can slow draining.	
	Empty pockets and use garment bags for small items.	
Using cycles with a lower spin speed.	Cycles with lower spin speeds remove less water than cycles with high spin speeds. Use the recommended cycle/speed spin for your item.	

Troubleshooting (continued)

First try the solutions suggested here or visit our website at www.whirlpool.com/product_help -
In Canada www.whirlpool.ca for assistance and to possibly avoid a service call.

If you experience	Possible Causes	Solution
Washer not performing as expected (cont.)		
Washer not draining/ spinning, loads are still wet (cont.)	Washer may be tightly packed or unbalanced.	Tightly packed loads may not allow the washer to spin correctly, leaving the load wetter than normal. Evenly arrange the wet load for balanced spinning. Select RINSE & SPIN to remove excess water. See "Using Your Washer" for loading recommendations.
	Load off balanced.	See "Vibration or Off-Balance" in Troubleshooting section for more information.
	Check plumbing for correct drain hose installation. Drain hose extends into standpipe farther than 4.5" (114 mm).	Check drain hose for proper installation. Use drain hose form and securely attach to drainpipe or tub. Do not tape over drain opening. Lower drain hose if the end is higher than 96" (2.4 m) above the floor. Remove any clogs from drain hose.
	Not using HE detergent or using too much HE detergent.	Suds from regular detergent or using too much detergent can slow or stop draining or spinning. Use only HE detergent. Always measure and follow detergent directions for your load. To remove extra suds, Select RINSE & SPIN. Do not add detergent.
Incorrect or wrong wash or rinse temperatures	Check for proper water supply.	Make sure hot and cold inlet hoses are not reversed.
		Both hoses must be attached to both washer and faucet, and have both hot and cold water flowing to inlet valve.
		Check that inlet valve screens are not clogged.
	Remove any kinks in hoses.	
Energy-saving controlled wash temperatures.	ENERGY STAR® qualified washers use cooler wash and rinse water temperatures than traditional top-load washers. This includes cooler hot and warm washes.	
Load not rinsed	Check for proper water supply.	Make sure hot and cold inlet hoses are not reversed.
		Both hoses must be attached and have water flowing to the inlet valve.
		Both hot and cold water faucets must be on.
		Inlet valve screens on washer may be clogged.
		Remove any kinks in the inlet hose.
	Not using HE detergent or using too much HE detergent.	The suds from regular detergent can cause the washer to operate incorrectly.
		Use only HE detergent. Be sure to measure correctly.
		Always measure detergent and follow detergent directions based on load size and soil level.
	Washer may be tightly packed.	The washer is less efficient at rinsing when load is tightly packed.
		Load items in loose heaps evenly around the washplate.
Use cycle designed for the fabrics being washed.		
Add only 1 or 2 additional items after washer has started.		
Sand, pet hair, lint, etc. on load after washing	Heavy sand, pet hair, lint, and detergent or bleach residues may require additional rinsing.	Add an Extra Rinse to the selected cycle.
Load is tangling	Washer not loaded as recommended.	Load items in loose heaps evenly around the washplate.
		Reduce tangling by mixing types of load items. Use the recommended cycle for the type of items being washed.
	Wash action and/or spin speed too fast for load.	Select a cycle with a slower wash action and slower spin speed. Note that items will be wetter than when using a higher speed spin.
Not cleaning or removing stains	Wash load not completely covered in water.	Washer senses load size and adds correct amount of water. This is normal and necessary for clothes to move.
	Added more water to washer.	Do not add more water to washer. Adding water lifts the items off the washplate, resulting in less effective cleaning.
	Washer not loaded as recommended.	Load items in loose heaps evenly around the washplate.
		Add only 1 or 2 additional items after washer has started.

Troubleshooting (continued)

First try the solutions suggested here or visit our website at www.whirlpool.com/product_help -
In Canada www.whirlpool.ca for assistance and to possibly avoid a service call.

If you experience	Possible Causes	Solution
Washer not performing as expected (cont.)		
Not cleaning or removing stains (cont.)	Not using HE detergent or using too much HE detergent.	The suds from regular detergent can prevent washer from operating correctly.
		Use only HE detergent. Be sure to measure correctly.
		Always measure detergent and follow detergent directions based on load size and soil level.
	Not using correct cycle for fabric type.	Use a higher soil level cycle option and warmer wash temperature to improve cleaning.
		If using Quick cycle, wash only a few items.
		Use Whites Normal cycle for tough cleaning.
		See the "Cycle Guide" to match your load with the best cycle.
	Not using dispensers.	Use dispensers to avoid chlorine bleach and fabric softener staining.
		Load dispensers before starting a cycle.
		Avoid overfilling.
Not washing like colors together.	Do not add products directly onto load.	
	Wash like colors together and remove promptly after the cycle is complete to avoid dye transfer.	
Odors	Monthly maintenance not done as recommended.	Run the Clean Washer cycle after every 30 washes. See "Washer Care" in "Washer Maintenance."
		Unload washer as soon as cycle is complete.
	Not using HE detergent or using too much HE detergent.	Use only HE detergent. Be sure to measure correctly.
		Always follow the detergent directions.
		See "Washer Care" section.
Fabric Damage	Sharp items were in pockets during wash cycle.	Empty pockets, zip zippers, and snap or hook fasteners before washing to avoid snags and tears.
	Strings and straps could have tangled.	Tie all strings and straps before starting wash load.
	Items may have been damaged before washing.	Mend rips and broken threads in seams before washing.
	Fabric damage can occur if the load is tightly packed.	Load items in loose heaps evenly around washplate.
		Load items should move freely during wash to avoid damage.
		Use cycle designed for the fabrics being washed.
		Add only 1 or 2 additional items after washer has started.
	Garment care instructions may not have been followed.	Always read and follow garment manufacturer's care label instructions. See the "Cycle Guide" to match your load with the best cycle.
	Liquid chlorine bleach may have been added incorrectly.	Do not pour liquid chlorine bleach directly onto load. Wipe up bleach spills.
		Undiluted bleach will damage fabrics. Do not use more than recommended by manufacturer.
		Do not place load items on top of bleach dispenser when loading and unloading washer.

Troubleshooting (continued)

First try the solutions suggested here or visit our website at www.whirlpool.com/product_help -
In Canada www.whirlpool.ca for assistance and to possibly avoid a service call.

If you experience	Possible Causes	Solution
Washer not performing as expected (cont.)		
Incorrect dispenser operation	Clogged dispensers or laundry products dispensing too soon.	Do not overfill dispenser. Overfilling causes immediate dispensing.
		Load dispensers before starting a cycle.
		It is normal for small amounts of water to remain in dispenser at the end of the cycle.
		Homes with low water pressure may result in residual powder in the dispenser. To avoid, select a warmer wash temperature if possible, depending on your load.
	Clean dispenser nozzle and make sure drawer is properly seated.	
	Liquid chlorine bleach not used in dispenser.	Use only liquid chlorine bleach in the bleach dispenser.
Single-dose laundry packet not dissolving	Adding laundry packet incorrectly.	Be sure laundry packet is added to washer basket before adding clothes. Follow the manufacturer's instructions to avoid damage to your items.
Error Code Appears in Display		
"LF" (F8E1) (too long to fill) appears in display	Washer taking too long to fill. Drain extends more than 4.5" (114 mm) into standpipe.	Check plumbing for correct drain hose installation. Use drain hose form and attach securely to drainpipe or tub. Do not tape over drain opening. See Installation Instructions.
F#E# code (F-type error code) appears in display	System error code.	Touch POWER to clear the code and exit cycle. Then touch POWER, select cycle, and then touch and hold START/PAUSE to start washer. If code appears again, call for service.
F1E1 ACU (Appliance control fault)	Internal ACU failure.	Call for service.
F2E3 UI/ACU mismatch	ACU/UI initialization error.	Call for service.
F3E1 Water level sensing failure	Pressure sensor on ACU failure.	Call for service.
F5E2 Lid lock will not lock is lid lock failure	An item in the load may be keeping the lid from locking.	Check for items directly under the lid.
F5E3 Lid cannot unlock	Objects on washer lid prevent it from unlocking.	Remove objects, such as baskets of laundry, from top of washer.
F6E2 or F6E3 Communication Error: UI cannot communicate	ACU or UI synchronization error.	Remove power from the washer. Let washer set for 5 minutes for the washer to completely power down. Apply power to washer and check for error codes. If the error code persists call for service.
F8E6 (Lid opened) appears in display	Washer lid left open.	Close the lid and touch Power to clear the display. If the lid is left open for more than 10 minutes, the cycle will reset and water in the washer will drain.
"drn" "dr" (F9E1) (drain pump system problem - long drain) appears in display	Washer taking too long to drain water. Drain extends more than 4.5" (114 mm) into standpipe.	Check plumbing for correct drain hose installation. Use drain hose form and attach securely to drainpipe or tub. Do not tape over drain opening.
		Lower drain hose if the end is higher than 96" (2.4 m) above the floor. Remove any clogs from drain hose. See Installation Instructions.

Notes

Section 3: Installation

This section provides installation requirements and procedures for the “Whirlpool 2014 CABRIO® Top Load Direct Drive Washer.”

- Installation Requirements
- Location Requirements
- Drain System
- Electrical Requirements
- Installation Instructions
- Connect Drain Hose
- Connect Inlet Hoses
- Level Washer
- Complete Installation Checklist
- Notes

INSTALLATION

Installation Requirements

Tools and Parts

Gather required tools and parts before starting installation.

Tools needed:

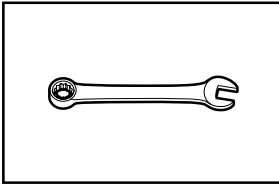

Adjustable or open end wrench $\frac{9}{16}$ " (14 mm)

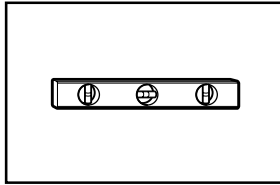

Level

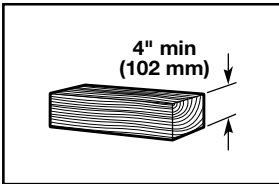

Wood block

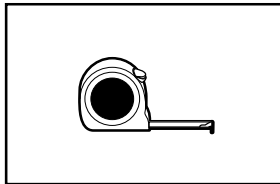

Ruler or measuring tape

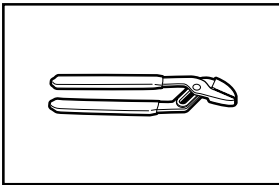

Pliers that open to $1\frac{3}{4}$ " (44.5 mm)

Optional tools:

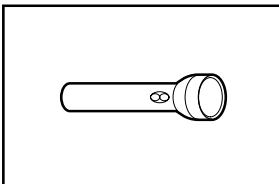

Flashlight

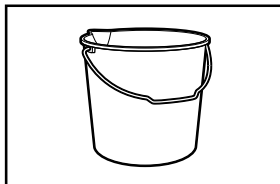

Bucket

Parts supplied:

NOTE: All parts supplied for installation are in cardboard insert in the top of the washer.

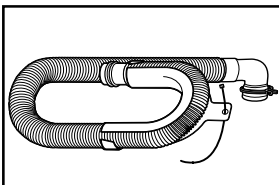

Drain hose with clamp, U-form, and cable tie

Parts needed: (Not supplied with washer)

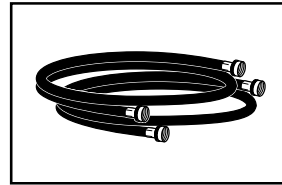

Inlet hoses with flat washers

To order, please refer to toll-free phone numbers on back page of your Use and Care Guide.

- 8212656RP 10 ft. (3.0 m) Inlet hose, Black EPDM (2 pack)
- 8212641RP 5 ft. (1.5 m) Inlet hose, Black EPDM (2 pack)
- 8212646RP 4 ft. (1.2 m) Inlet hose, Black EPDM (2 pack)
- 8212545RP 5 ft. (1.5 m) Inlet hose, Red and Blue EPDM (2 pack)
- 8212487RP 5 ft. (1.5 m) Nylon braided inlet hose (2 pack)
- 8212638RP 6 ft. (1.8 m) Nylon braided inlet hose, space saving 90° elbow, hydro-blue steel couplings (2 pack)
- 8212637RP 6 ft. (1.8 m) Inlet hose, Black EPDM, space saving 90° elbow, hydro-blue steel couplings (2 pack)

Alternate parts: (Not supplied with washer)

Your installation may require additional parts. To order, please refer to toll-free numbers on back page of your Use and Care Guide.

If you have:

Overhead sewer

1" (25 mm) standpipe

Drain hose too short

Lint clogged drain

You will need:

Standard 20 gal. (76 L) 39" (990 mm) tall drain tub or utility sink, sump pump and connectors (available from local plumbing suppliers)

2" (51 mm) diameter to 1" (25 mm) diameter Standpipe Adapter Part Number 3363920
Connector Kit Part Number 285835

Extension Drain Hose Part Number 285863
Connector Kit Part Number 285835

Drain Protector Part Number 367031
Connector Kit Part Number 285835

LOCATION REQUIREMENTS

Select proper location for your washer to improve performance and minimize noise and possible "washer walk". Install your washer in a basement, laundry room, closet, or recessed area.

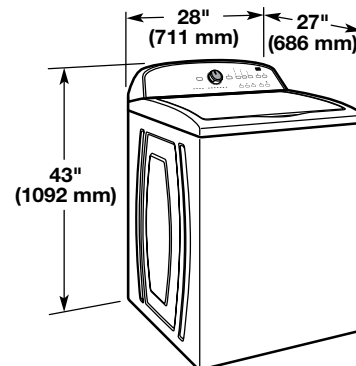

You will need:

- A water heater set to 120° F (49° C).
- A grounded electrical outlet located within 4 ft (1.2 m) of power cord on back of washer.
- Hot and cold water faucets located within 3 ft (0.9 m) of hot and cold water fill valves on washer, and water pressure of 20-100 psi (138-690 kPa).
- A level floor with maximum slope of 1" (25 mm) under entire washer. Installing on carpet is not recommended.
- Floor must support washer's total weight (with water and load) of 315 lbs (143 kgs).

IMPORTANT: Do not install, store, or operate washer where it will be exposed to weather or in temperatures below 32° F (0° C). Water remaining in washer after use may cause damage in low temperatures. See "Washer Care" in your Use and Care Guide for winterizing information.

Proper installation is your responsibility.

Recessed area or closet installation

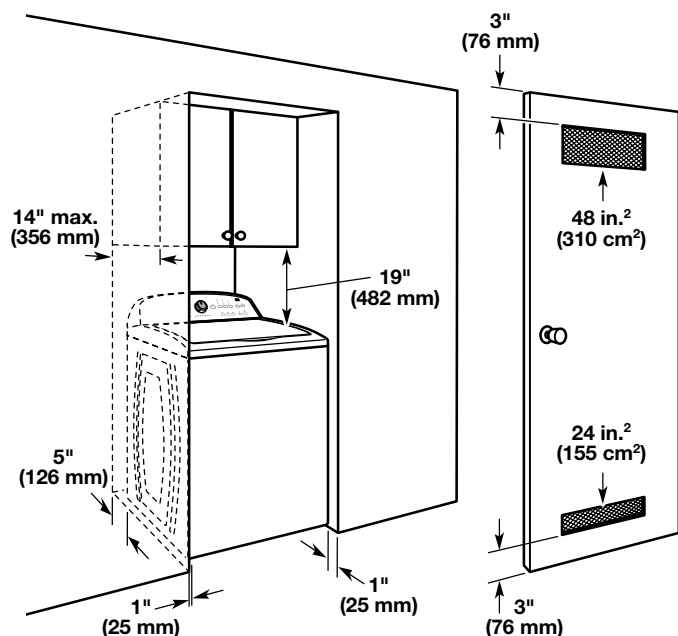

Dimensions show recommended spacing allowed, except for closet door ventilation openings which are minimum required. This washer has been tested for installation with spacing of 0" (0 mm) clearance on the sides. Consider allowing more space for ease of installation and servicing, and spacing for companion appliances and clearances for walls, doors, and floor moldings. Add spacing of 1" (25 mm) on all sides of washer to reduce noise transfer. If a closet door or louvered door is installed, top and bottom air openings in door are required.

DRAIN SYSTEM

Drain system can be installed using a floor drain, wall standpipe, floor standpipe, or laundry tub. Select method you need.

Floor standpipe drain system

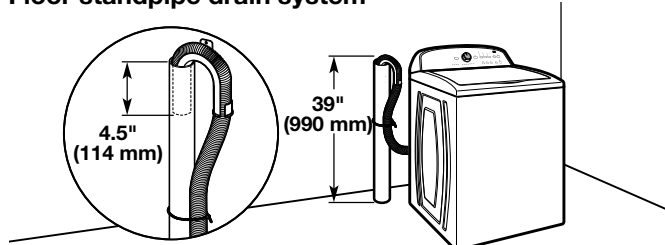

Minimum diameter for a standpipe drain: 2" (51 mm). Minimum carry-away capacity: 17 gal. (64 L) per minute. Top of standpipe must be at least 39" (990 mm) high; install no higher than 96" (2.44 m) from bottom of washer. If you must install higher than 96" (2.44 m), you will need a sump pump system.

Wall standpipe drain system

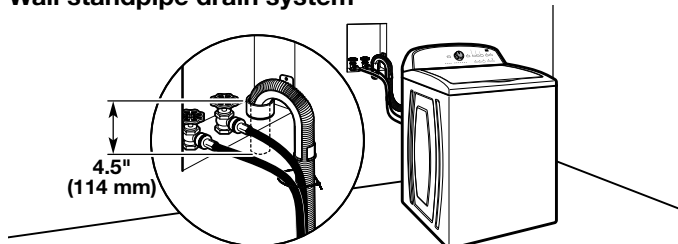

See requirements for floor standpipe drain system.

Floor drain system

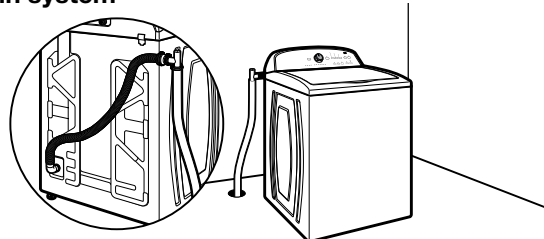

Floor drain system requires a Siphon Break Kit (Part Number 285834), 2 Connector Kits (Part Number 285835), and an Extension Drain Hose (Part Number 285863) that may be purchased separately. To order, please see toll-free phone numbers in your Use and Care Guide. Minimum siphon break: 28" (710 mm) from bottom of washer. (Additional hoses may be needed.)

Laundry tub drain system

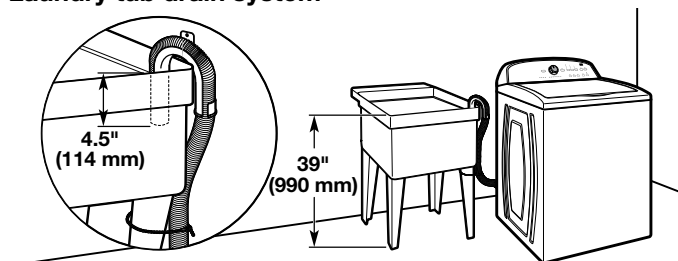

Minimum capacity: 20 gal. (76 L). Top of laundry tub must be at least 39" (990 mm) above floor; install no higher than 96" (2.44 m) from bottom of washer.

IMPORTANT: To avoid siphoning, no more than 4.5" (114 mm) of drain hose should be inside standpipe or below the top of wash tub. Secure drain hose with cable tie.

INSTALLATION

ELECTRICAL REQUIREMENTS

⚠ WARNING



Electrical Shock Hazard

Plug into a grounded 3 prong outlet.

Do not remove ground prong.

Do not use an adapter.

Do not use an extension cord.

Failure to follow these instructions can result in death, fire, or electrical shock.

- A 120 volt, 60 Hz., AC only, 15- or 20-amp, fused electrical supply is required. A time-delay fuse or circuit breaker is recommended. It is recommended that a separate circuit breaker serving only this appliance be provided.
- This washer is equipped with a power supply cord having a 3 prong grounding plug.
- To minimize possible shock hazard, the cord must be plugged into a mating, 3 prong, grounding-type outlet, grounded in accordance with local codes and ordinances. If a mating outlet is not available, it is the personal responsibility and obligation of the customer to have the properly grounded outlet installed by a qualified electrician.
- If codes permit and a separate ground wire is used, it is recommended that a qualified electrician determine that the ground path is adequate.
- Do not ground to a gas pipe.
- Check with a qualified electrician if you are not sure the washer is properly grounded.
- Do not have a fuse in the neutral or ground circuit.

GROUNDING INSTRUCTIONS

For a grounded, cord-connected washer:

This washer must be grounded. In the event of a malfunction or breakdown, grounding will reduce the risk of electrical shock by providing a path of least resistance for electric current. This washer is equipped with a cord having an equipment-grounding conductor and a grounding plug. The plug must be plugged into an appropriate outlet that is properly installed and grounded in accordance with all local codes and ordinances.

WARNING: Improper connection of the equipment-grounding conductor can result in a risk of electric shock. Check with a qualified electrician or serviceman if you are in doubt as to whether the appliance is properly grounded.

Do not modify the plug provided with the appliance – if it will not fit the outlet, have a proper outlet installed by a qualified electrician.

For a permanently connected washer:

This washer must be connected to a grounded metal, permanent wiring system, or an equipment grounding conductor must be run with the circuit conductors and connected to the equipment-grounding terminal or lead on the appliance.

INSTALLATION INSTRUCTIONS

⚠ WARNING

Excessive Weight Hazard

Use two or more people to move and install washer.

Failure to do so can result in back or other injury.

Before you start: remove shipping materials

It is necessary to remove all shipping materials for proper operation and to avoid excessive noise from washer.

1. Move washer

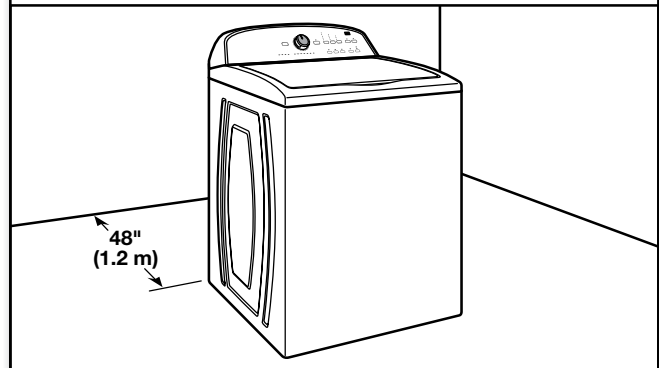

Move washer to within 4 ft (1.2 m) of its final location; it must be in a fully upright position.

NOTE: To avoid floor damage, set washer onto cardboard before moving it and make sure lid is taped shut.

2. Remove shipping base

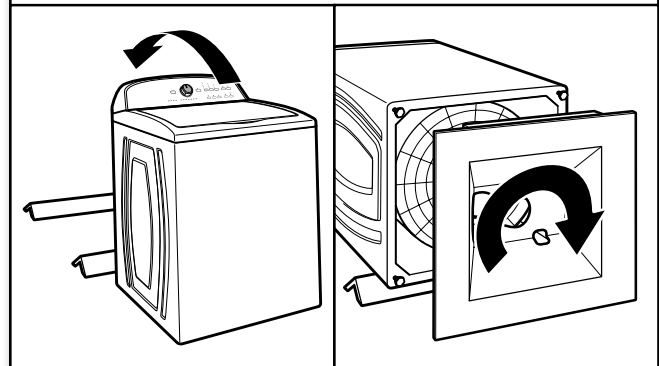

To avoid damaging floor, place cardboard supports from shipping carton on floor behind washer. Tip washer back and place on cardboard supports. Remove shipping base by rotating base 90° to the right. Set washer upright.

IMPORTANT: Removing shipping base is necessary for proper operation. If your washer includes a sound shield, please refer to the instructions included with the sound shield to install it at this time.

3. Remove packing tray from tub

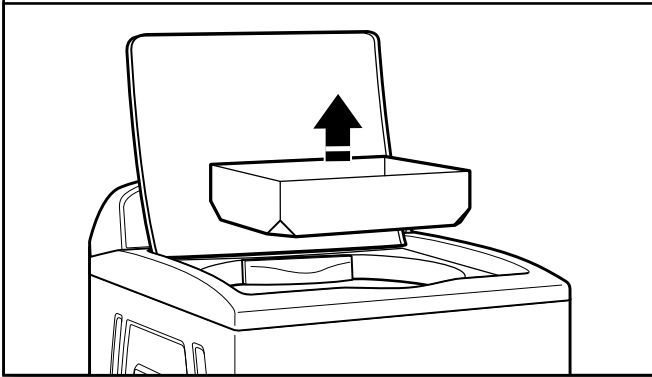

Remove tape from washer lid, open lid and remove cardboard packing tray from tub. Be sure to remove all parts from tray.

NOTE: Keep tray in case you need to move washer later.

4. Free power cord

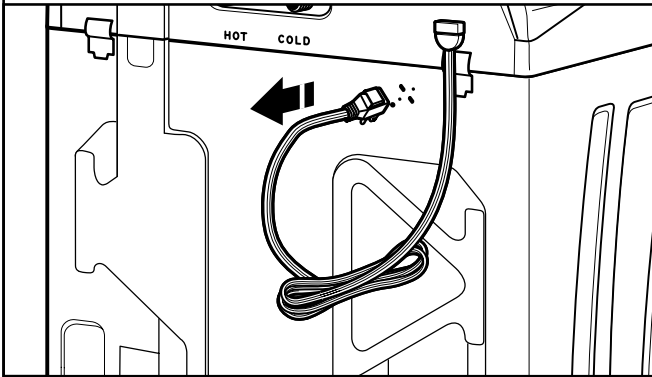

Firmly grasp power cord plug and pull to free from rear panel. Gently place power cord over console to allow free access to back of washer.

CONNECT DRAIN HOSE

5. Attach drain hose to drain port

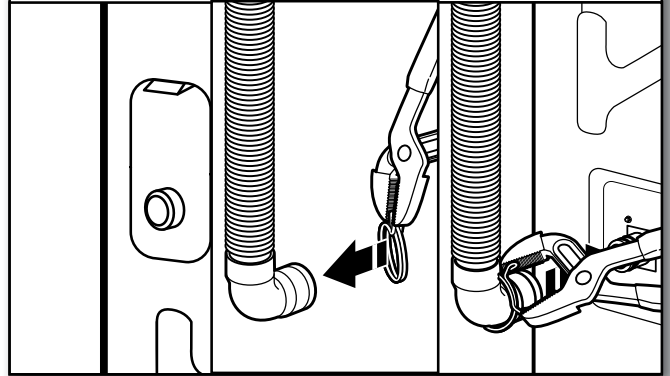

If clamp is not already in place on elbow end of drain hose, slide it over end as shown. Squeeze clamp with pliers and slide black elbow end of drain hose onto black drain port and secure with clamp.

For a laundry tub or standpipe drain, go to step 6.

For a floor drain, remove the preinstalled drain hose form as shown in Step 7. You may need additional parts with separate directions. See "Tools and Parts".

6. Place drain hose in standpipe

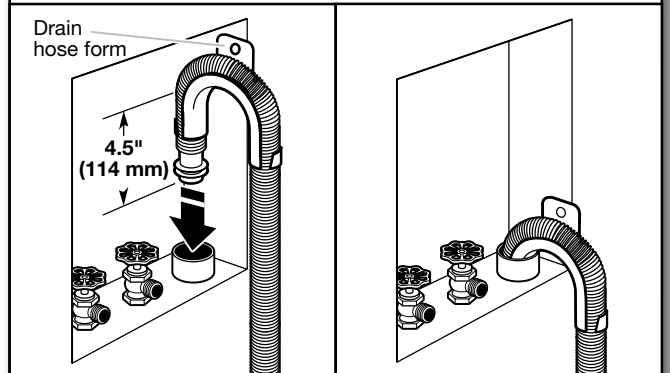

Place hose into standpipe (shown in picture) or over side of laundry tub.

IMPORTANT: 4.5" (114 mm) of drain hose should be inside standpipe; do not force excess hose into standpipe or lay on bottom of laundry tub. Drain hose form must be used.

INSTALLATION

7. Remove drain hose form (floor drain installations only)

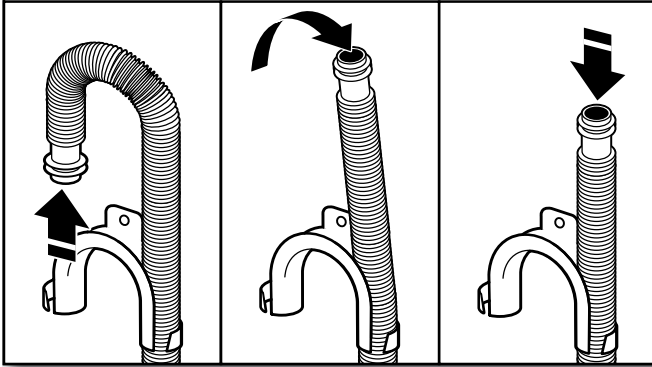

For floor drain installations, you will need to remove the drain hose form from the end of the drain hose. You may need additional parts with separate directions. See “Tools and Parts”.

CONNECT INLET HOSES

Washer must be connected to water faucets with new inlet hoses with flat washers (not provided). Do not use old hoses.

NOTE: Both hoses must be attached and have water flowing to inlet valves. If you are only connecting to a cold water faucet, you must use a Y-adaptor (not provided).

8. Connect inlet hoses to water faucets

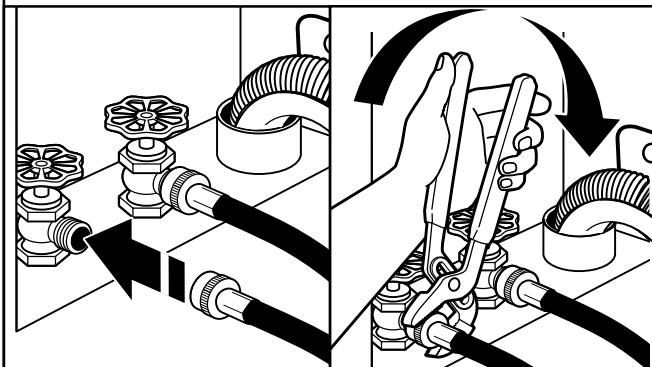

Attach hose to hot water faucet. Screw on coupling by hand until it is seated on washer. Use pliers to tighten couplings an additional two-thirds turn. Repeat this step with second hose for cold water faucet.

IMPORTANT: Do not overtighten or use tape or sealants on valve when attaching to faucets or washer. Damage can result.

9. Clear water lines

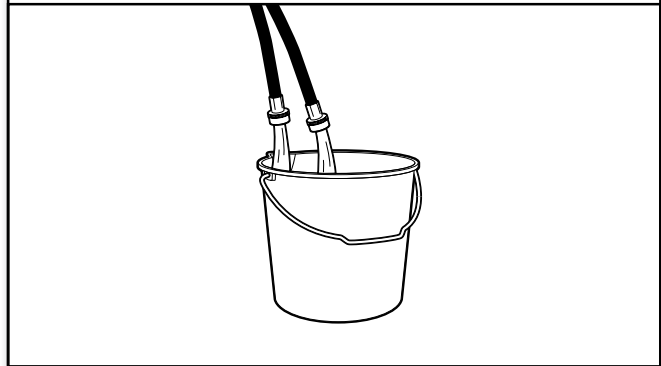

Run water for a few seconds through hoses into a laundry tub, drainpipe, or bucket to avoid clogs. Water should run until clear.

Make note of which hose is connected to hot water to help in attaching hoses to washer correctly.

10. Connect inlet hoses to washer

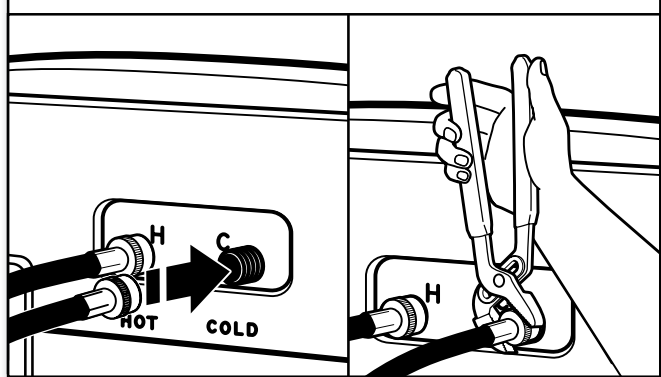

Attach hot water hose to hot water inlet valve marked with a red ring. Screw coupling by hand until it is snug. Use pliers to tighten couplings an additional two-thirds turn. Repeat with cold water inlet valve.

IMPORTANT: To reduce risk of hose failure, replace the hoses every 5 years. Record hose installation or replacement dates for future reference.

- Periodically inspect and replace hoses if bulges, kinks, cuts, wear, or leaks are found.

11. Check for leaks

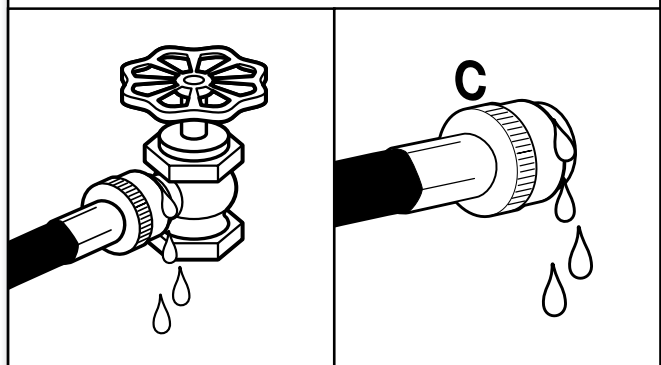

Turn on water faucets to check for leaks. A small amount of water may enter washer. It will drain later.

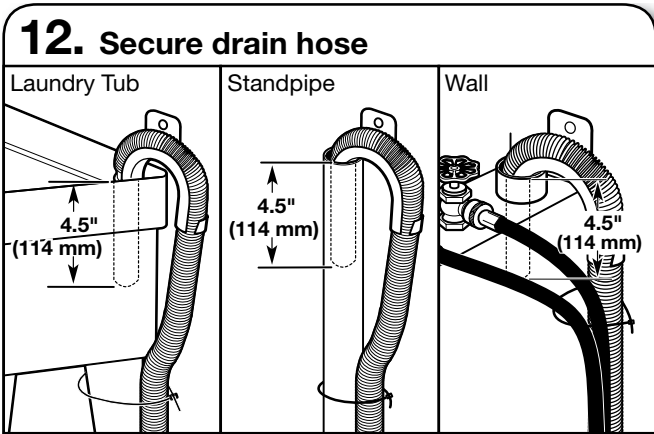

Secure drain hose to laundry tub leg, drain standpipe, or inlet hoses for wall standpipe with cable tie.

LEVEL WASHER

IMPORTANT: Level washer properly to reduce excess noise and vibration.



Move the washer to its final location. Place a level on top edges of washer. Use side seam as a guide to check levelness of sides. Check levelness of front using lid, as shown. Rock washer back and forth to make sure all four feet make solid contact with floor. If washer is level, skip to step 15, (on models with metal feet) or step 16 (on models with plastic feet).

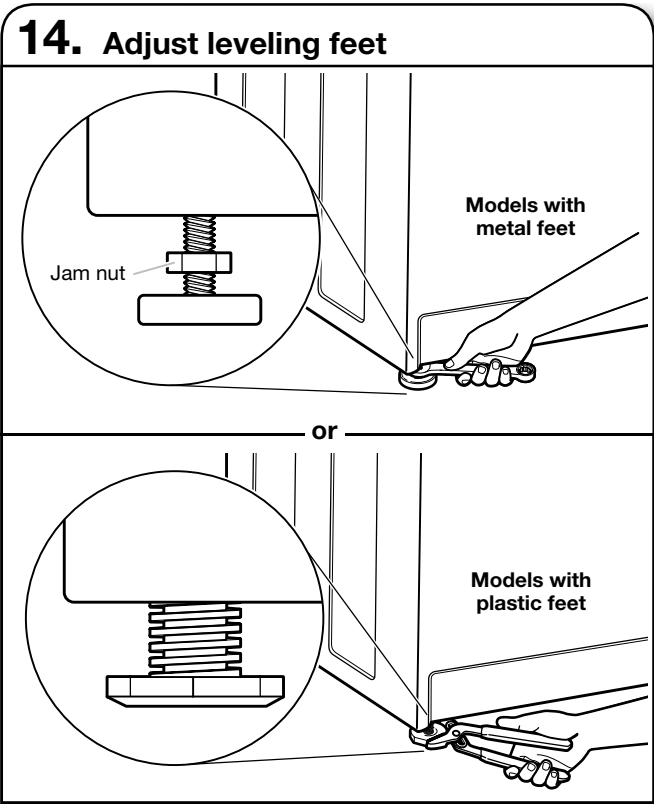
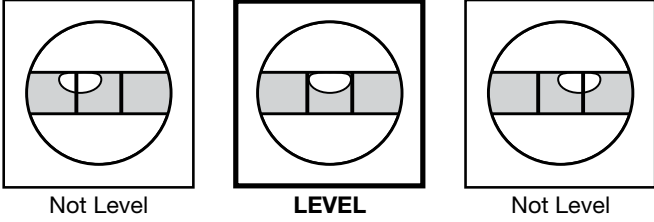

If washer is not level:
 On models with metal feet, use a 9/16" or 14 mm open-end or adjustable wrench to turn jam nuts clockwise on feet until they are about 1/2" (13 mm) from the washer cabinet. Then turn the leveling foot clockwise to lower the washer or counterclockwise to raise the washer.

On models with plastic feet, use adjustable pliers to turn the plastic leveling foot counterclockwise to lower the washer or clockwise to raise the washer. On all models, recheck levelness of washer and repeat as needed.

HELPFUL TIP: You may want to prop up front of washer about 4" (102 mm) with a wood block or similar object that will support weight of washer.

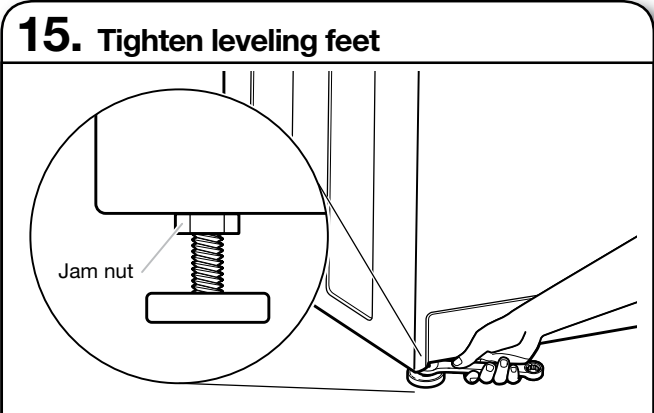

On models with metal feet, when washer is level, use a 9/16" or 14 mm open-end or adjustable wrench to turn jam nuts counterclockwise on leveling feet tightly against washer cabinet.

HELPFUL TIP: You may want to prop washer with wooden block.

⚠ WARNING



Electrical Shock Hazard

Plug into a grounded 3 prong outlet.

Do not remove ground prong.

Do not use an adapter.

Do not use an extension cord.

Failure to follow these instructions can result in death, fire, or electrical shock.

16. Plug into a grounded 3 prong outlet

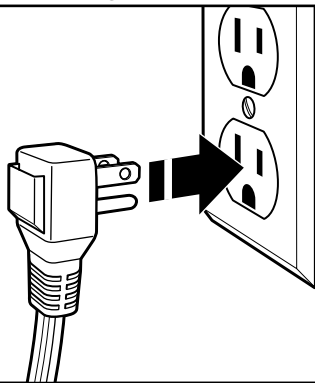

COMPLETE INSTALLATION CHECKLIST

- Check electrical requirements. Be sure you have correct electrical supply and recommended grounding method.
- Check that all parts are now installed. If there is an extra part, go back through steps to see what was skipped.
- Check that you have all of your tools.
- Check that shipping materials were completely removed from washer.
- Check that water faucets are on.
- Check for leaks around faucets and inlet hoses.
- Remove protective film from console and any tape remaining on washer.
- Check that washer is plugged into a grounded 3 prong outlet.
- Dispose of/recycle all packaging materials.
- Read "Washer Care" in your Use and Care Guide.
- To test and clean your washer, measure 1/2 of normal recommended amount of powdered or liquid detergent and pour it into washer basket or detergent dispenser (on some models). Close lid. Select any cycle. Start washer and allow to complete full cycle.

Notes

Section 4: Component Access

This section provides service parts access, removal, and installation instructions for the “Whirlpool 2014 CABRIO® Top Load Direct Drive Washer.”

- Component Locations
- Removing the Console-Method A
- Removing the Console-Method B
- Removing the User Interface (UI)
- Removing the Water Inlet Valve
- Removing the Main Control
- Removing the Tub Ring, Impeller, and Basket
- Removing the Motor and Drive Assembly
- Removing the Pumps
- Removing the Heater
- Removing the Lid Lock
- Removing the Lid and a Hinge

Component Locations

CONSOLE ELECTRONICS & VALVES

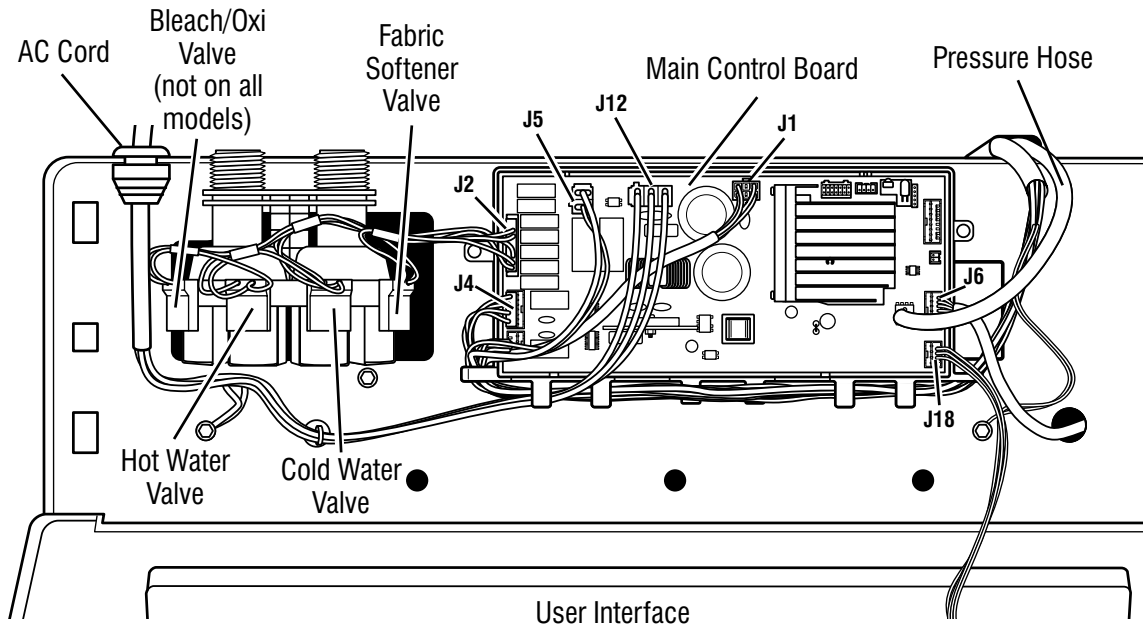

BOTTOM VIEW — DRIVE SYSTEM & PUMPS*

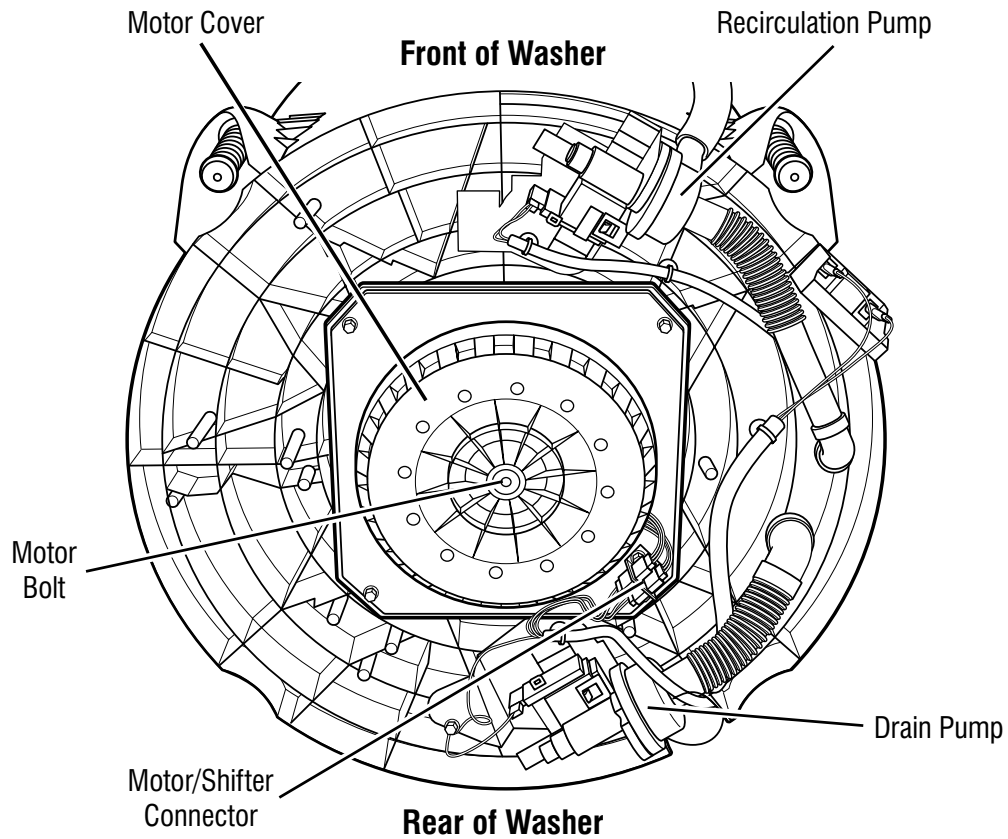



Removing the Console—Method A

WARNING



Electrical Shock Hazard
 Disconnect power before servicing.
 Replace all parts and panels before operating.
 Failure to do so can result in death or electrical shock.

Removing the Console—Method A

The new sleek contoured design of the User Interface makes access of the console a bit of a challenge. Since the console is recessed into the top panel (see Figure 1), the usual method of sliding a tool under the console to release the clips can be a bit tricky.

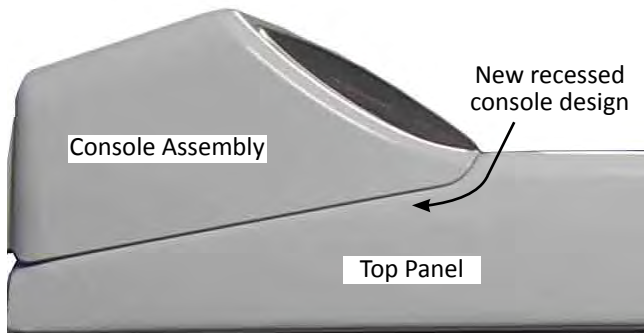

Figure 1

Modify the Putty Knife

A putty knife can work, but it should be plastic and modified as shown in Figure 2 so that it can be maneuvered around the screw, which is placed directly in front of the release clips.

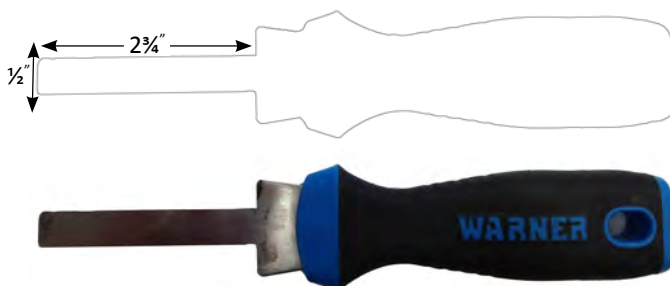

Figure 2

1. Unplug washer or disconnect power.
2. Turn off water supply to washer.
3. Remove two (2) 1/4" hex-head mounting screws from the rear of the console as indicated in Figure 3.



Figure 3

4. Slide the putty knife down between the console assembly and top panel. Use your free hand to push back on the top of the console while you flex and maneuver the putty knife up and around the screw. (See Figures 4 & 5).



Figure 4

5. Depress the console clip with the putty knife and lift up on the console to separate from top panel (see Figure 5). Tilt the console forward for service.



Figure 5



Removing the Console—Method B

⚠ WARNING



Electrical Shock Hazard
 Disconnect power before servicing.
 Replace all parts and panels before operating.
 Failure to do so can result in death or electrical shock.

Removing the Console—Method B

1. Unplug washer or disconnect power.
2. Turn off water supply to washer.
3. Tape lid down.
4. Remove five (5) 1/4" hex-head mounting screws from the rear of the console as indicated in Figure 1. Remove harness cover and set aside.



Figure 1

5. Slide top forward about 1/2" (see Figure 2).



Figure 2

6. Raise the top about 1/4". Then, while still keeping it lifted, push the top back about 1/4" (see Figure 3).

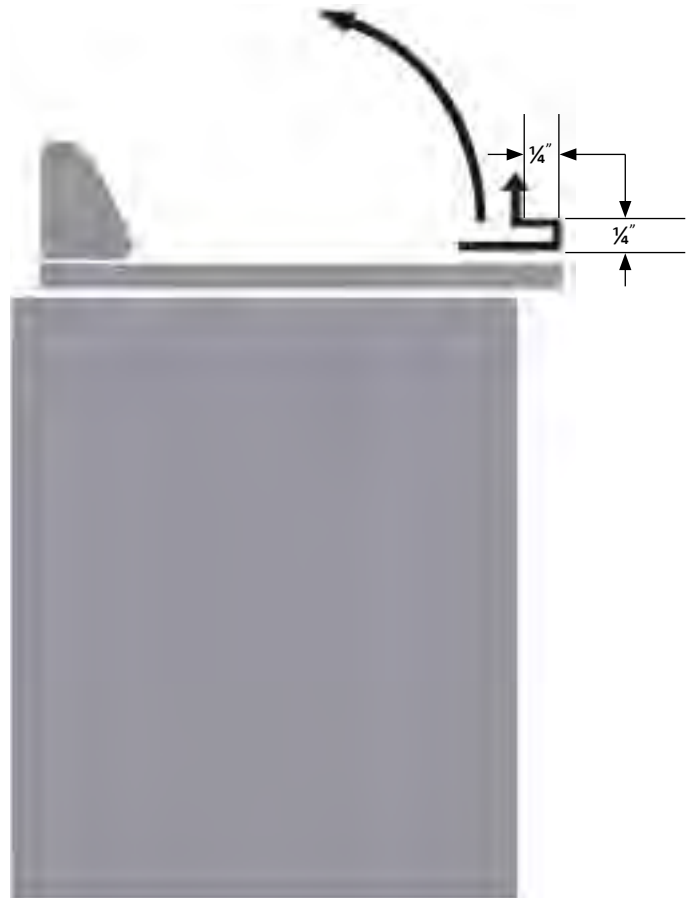

Figure 3

7. Tilt the top up on the rear hinges.
8. Using a flat blade screwdriver, depress the console clips (identified by the two arrows) to release console from top panel (see Figure 4).

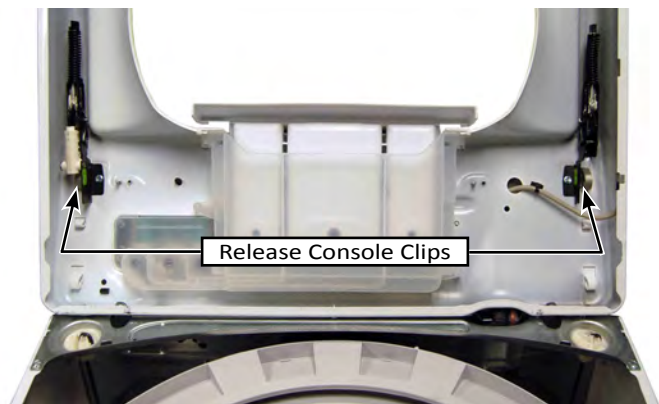

Figure 4



Removing the User Interface (UI)

⚠ WARNING



Electrical Shock Hazard
 Disconnect power before servicing.
 Replace all parts and panels before operating.
 Failure to do so can result in death or electrical shock.

4. Remove the seven (7) 1/4" hex-head screws securing the User Interface to the console (see Figure 2).
5. Using a flat blade screwdriver, gently, depress the six plastic mounting clips to release the User Interface from the console (see Figure 2).
6. User Interface should separate and lift away from console.

REASSEMBLY NOTE: When reinstalling the User Interface to the console, only hand tighten the seven (7) hex-head screws until snug. Using a power driver will strip the screw holes and stress the capacitive touch user interface.

Removing the User Interface

1. Unplug washer or disconnect power.
2. Perform the procedures on pages 4-3 or 4-4, "Removing the Console" prior to performing the following steps.
3. Disconnect the 3-wire harness from the User Interface (see Figure 1).

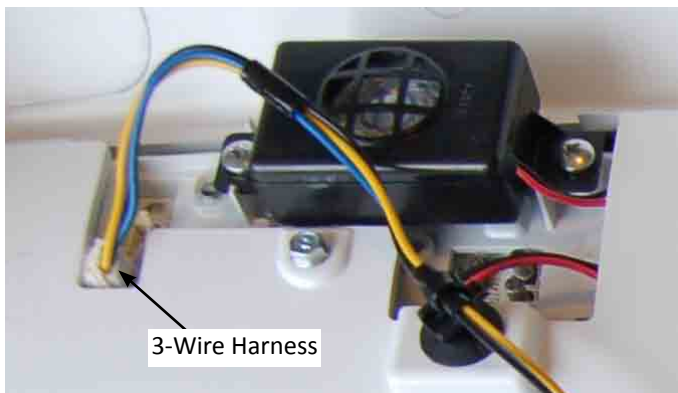

Figure 1

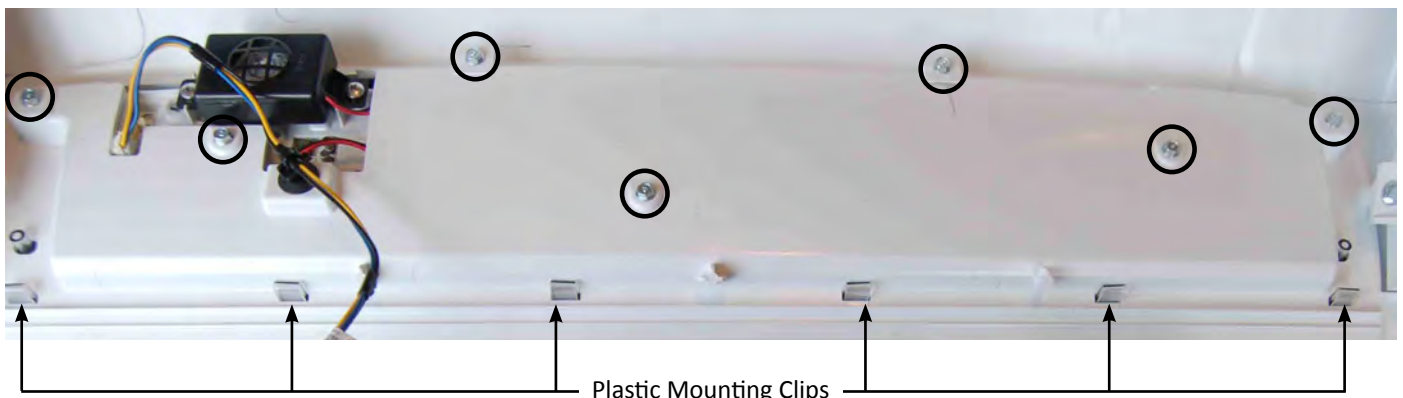

Figure 2

COMPONENT ACCESS



Removing the Water Inlet Valve

⚠ WARNING



Electrical Shock Hazard
Disconnect power before servicing.
Replace all parts and panels before operating.
Failure to do so can result in death or electrical shock.

- Using a 1/4" nut driver, remove the two (2) hex-head screws (one on each side) securing the water inlet valve to the top panel of the washer. (See Figures 2 and 3.)

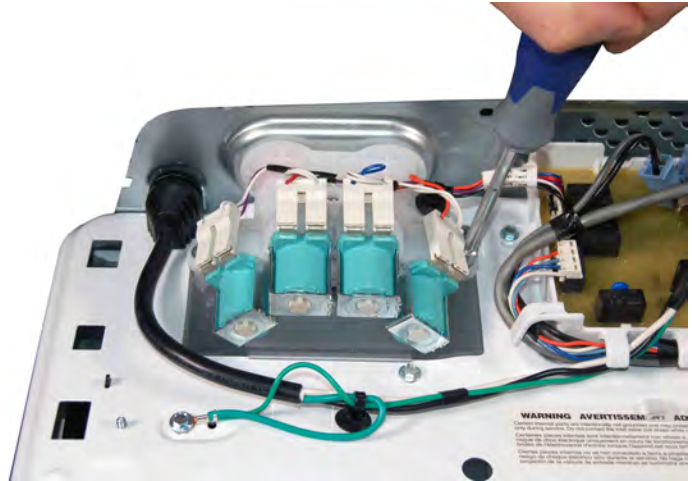

Figure 2

Removing the Water Inlet Valve

NOTE: The water inlet valve is replaced as an assembly, which includes all four valves, bracket, and valve assembly harness.

- Unplug washer or disconnect power.
- Turn off water supply to washer.
- Disconnect hot and cold inlet water hoses.
- Perform the procedures on pages 4-3 or 4-4, "Removing the Console" prior to performing the following steps.
- Disconnect the Water Inlet Valve connector "J2" from the Main Control (see Figure 1).

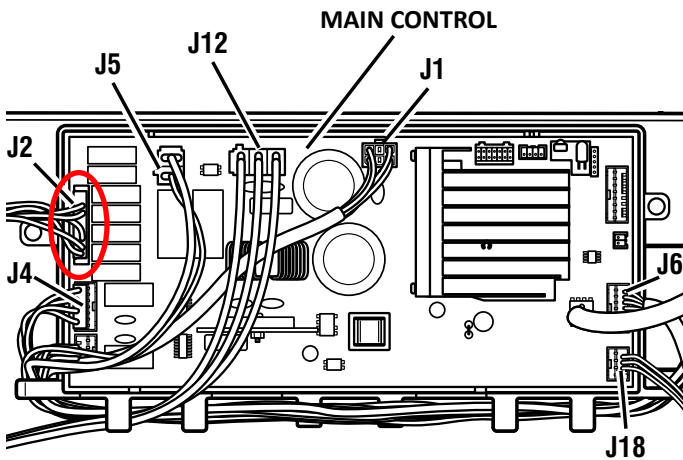

Figure 1

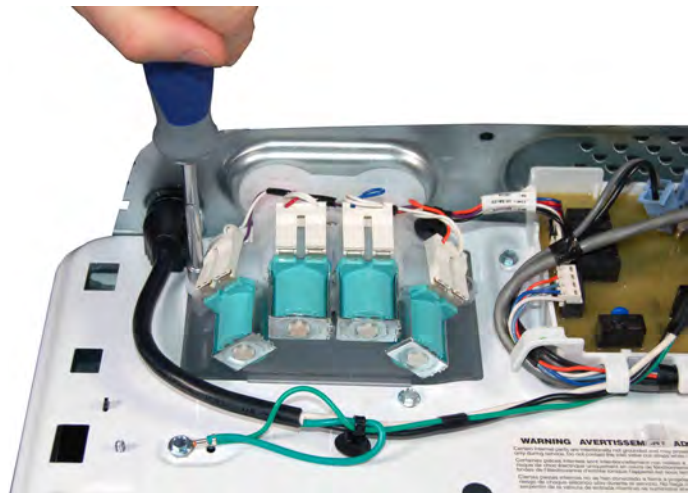

Figure 3



Removing the Main Control

⚠ WARNING



Electrical Shock Hazard
 Disconnect power before servicing.
 Replace all parts and panels before operating.
 Failure to do so can result in death or electrical shock.

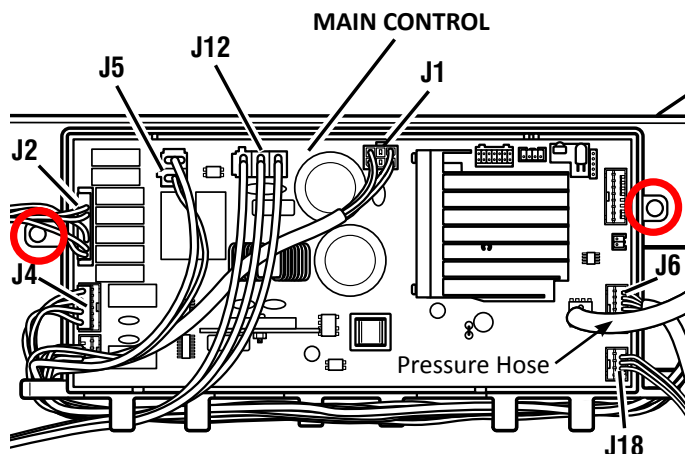

Figure 1

Removing the Main Control

IMPORTANT: Electrostatic Discharge (ESD) Sensitive Device. Failure to follow the ESD precautions outlined at the beginning of Section 6 "Testing" may destroy, damage, or weaken the main control assembly.

1. Unplug washer or disconnect power.
2. Turn off water supply to washer.
3. Perform the procedures on pages 4-3 or 4-4, "Removing the Console" prior to performing the following steps.
4. Remove pressure hose from Main Control (see Figure 1).
5. Disconnect all connectors from the Main Control (see Figure 1).
6. Using a 1/4" nut driver, remove the two (2) hex-head screws (locations circled in Figure 1) securing the main control to the top panel of the washer.

Connector	Component(s)
J1	Motor
J2	Valves & Thermistors
J4	Pumps & Clutch Coil
J5	Heater Element
J6	Lid Lock
J12	Power Cord
J18	User Interface



Removing the Tub Ring, Impeller, and Basket

⚠ WARNING



Electrical Shock Hazard
 Disconnect power before servicing.
 Replace all parts and panels before operating.
 Failure to do so can result in death or electrical shock.

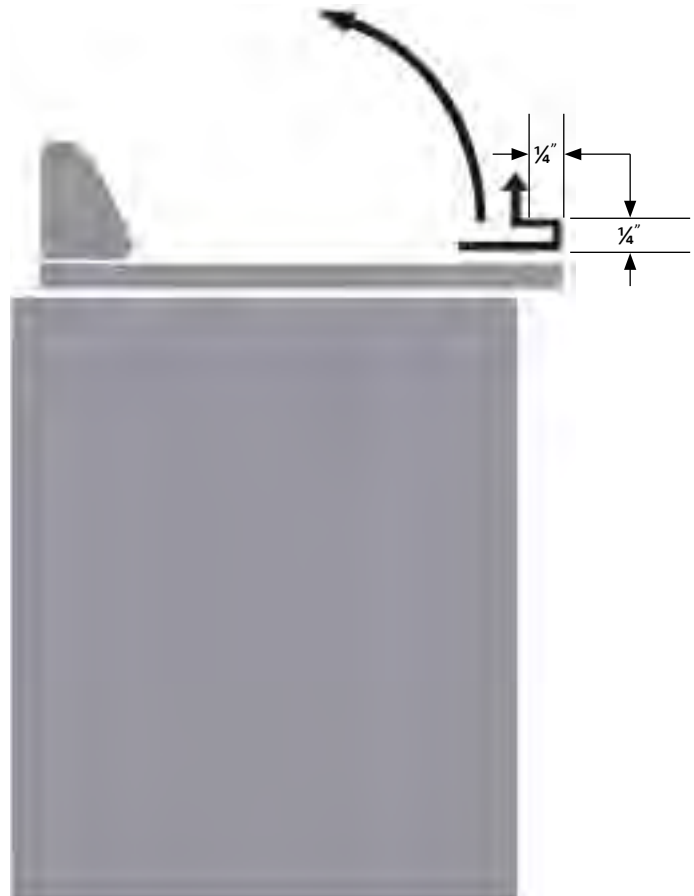

Figure 3

Lifting the Top Panel

1. Unplug washer or disconnect power.
2. Turn off water supply to washer.
3. Disconnect hot and cold inlet water hoses.
4. Tape lid down.
5. Remove three (3) 1/4" hex-head mounting screws from the rear of the console as indicated in Figure 1. Remove harness cover and set aside.



Figure 1

6. Slide top forward about 1/2" (see Figure 2).



Figure 2

7. Raise the top about 1/4". Then, while still keeping it lifted, push the top back about 1/4" (see Figure 3).

8. Tilt the top up on the rear hinges.

Removing the Tub Ring, Impeller, and Basket (continued)

Removing the Tub Ring

NOTE: Due to the increase in size and depth of the tub ring, the working space between the tub ring and side panel is very limited.

1. Disconnect recirculation hose from tub ring.
2. Locate the six (6) tub ring clips illustrated in Figure 4. Unclip each clip with a "stubby" flat blade screwdriver.

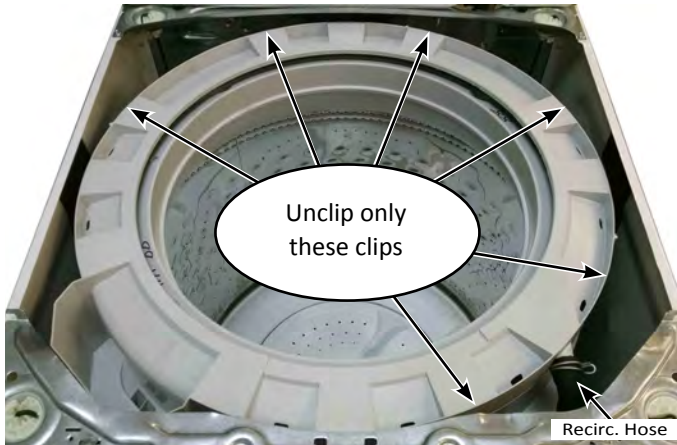

Figure 4

3. Lift-up the left-rear suspension rod and disconnect it from the rear brace (see Figure 5). This will allow more room to access the two clips located on both sides of the bleach well. Remove tub ring from washer.

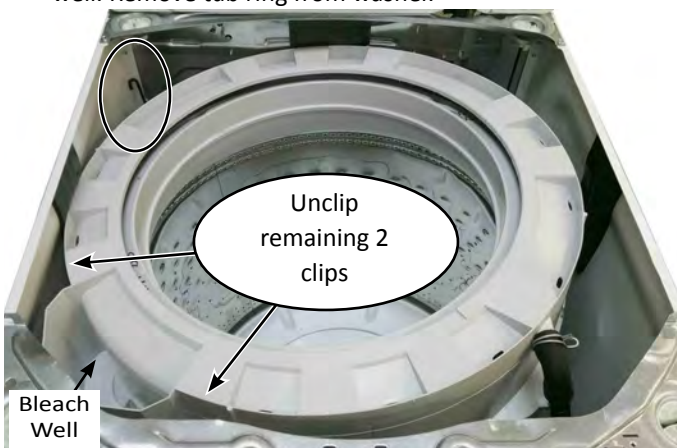

Figure 5

Removing the Impeller

1. Insert the blade from a small screwdriver into the slot in the impeller cap, then pry the cap up and remove it (see Figure 6).

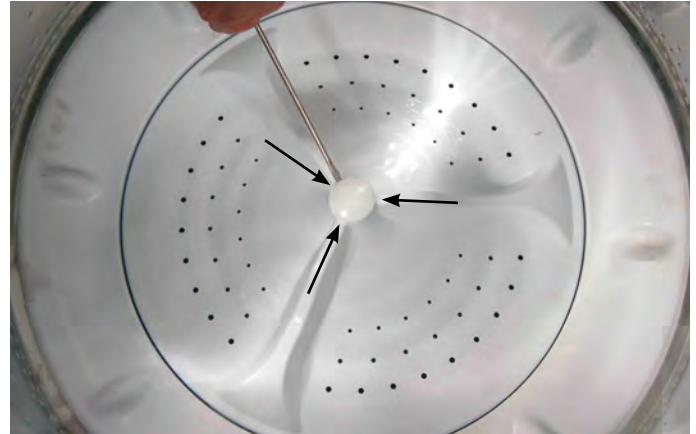

Figure 6

2. Remove the 7/16" hex-head bolt from the impeller, then lift and remove the impeller from the basket (see Figure 7).

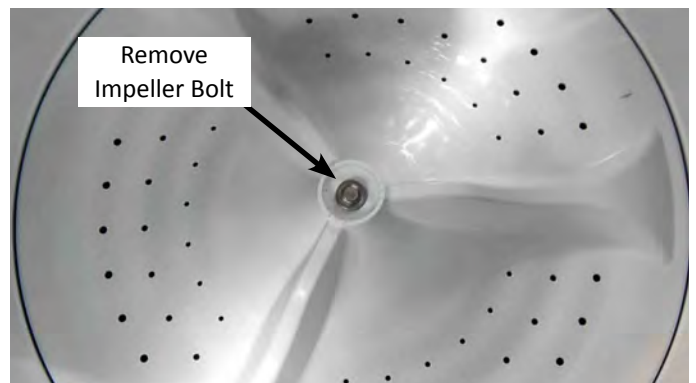

Figure 7

REASSEMBLY NOTE: Any time the impeller bolt is removed, Loctite® adhesive (Threadlocker Blue 242® or similar adhesive) must be reapplied, otherwise the bolt will eventually work itself loose resulting in a second call.



COMPONENT ACCESS

Removing the Tub Ring, Impeller, and Basket (continued)

Removing the Basket

1. Using a Spanner Wrench and hammer, tap wrench with hammer until nut becomes loose (see Figure 8). Remove Spanner Nut.



Figure 8

REASSEMBLY NOTE: When re-installing the basket, screw on spanner nut until it is finger tight. Then, using a mallet or hammer, tighten an additional $\frac{3}{4}$ turn (see Figure 10). Do NOT apply Loctite® to spanner nut. Applying Loctite® to the spanner nut will make it virtually impossible to remove again.

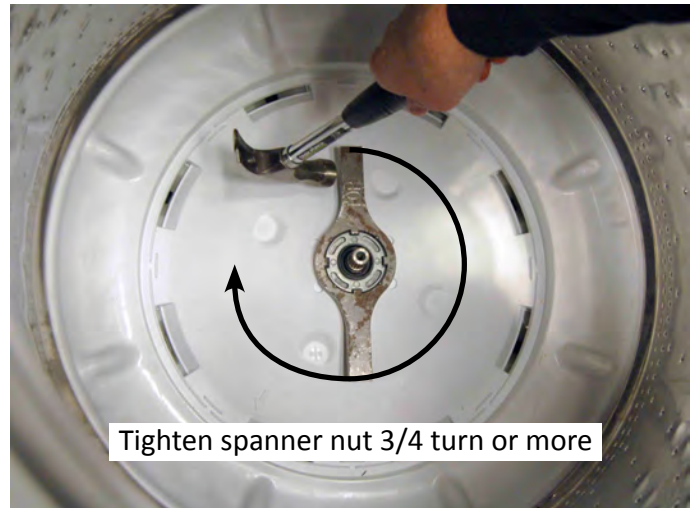

Figure 10

2. Lift the basket out of the washer.



Figure 9



Removing the Motor and Drive Assembly

WARNING



Electrical Shock Hazard
 Disconnect power before servicing.
 Replace all parts and panels before operating.
 Failure to do so can result in death or electrical shock.

Preparation

1. Unplug washer or disconnect power.
2. Turn off water supply to washer.
3. Disconnect hot and cold inlet water hoses and remove the drain hose from the standpipe or laundry tub.
4. Tape the washer lid closed.
5. Carefully lay the washer on its back panel. Place padding on the floor to protect the surfaces.
6. Remove sound padding and set aside.

Removing the Rotor, Clutch Coil, and Stator

1. Use a 4mm Allen wrench to remove the rotor mounting screw (see Figure 1). Rock the rotor back and forth until the rotor has been pulled away from the stator.

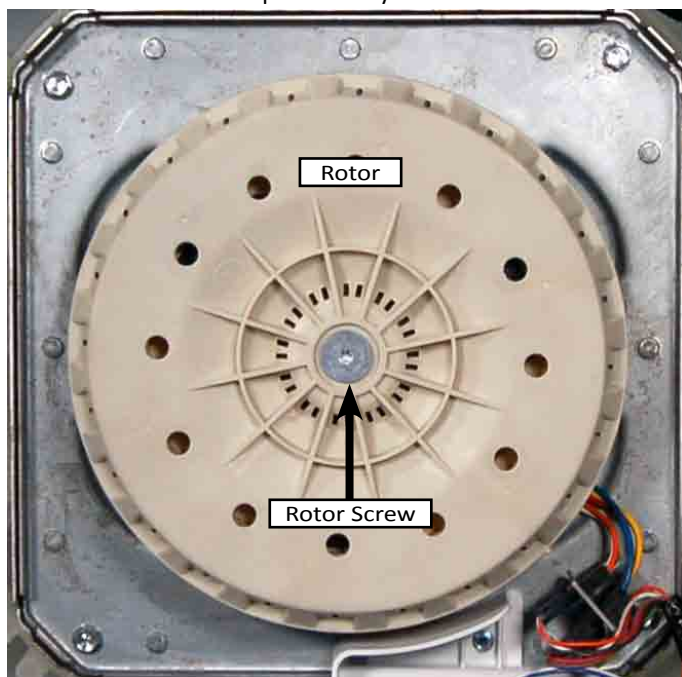

Figure 1

2. Unplug the clutch coil and stator connectors. Remove all connectors from the bracket (see Figure 2).
3. Use a 7mm socket to remove the three (3) clutch coil mounting screws. Allow the clutch coil to hang until the stator is removed (see Figure 2).

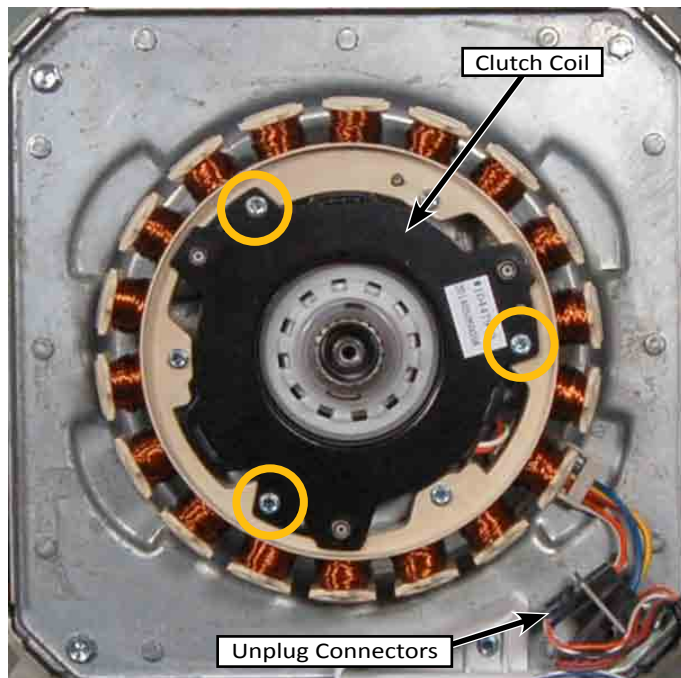

Figure 2

4. Use a 7mm socket to remove the three (3) stator mounting screws. Remove and set aside both the stator and clutch coil assembly (see Figure 3).

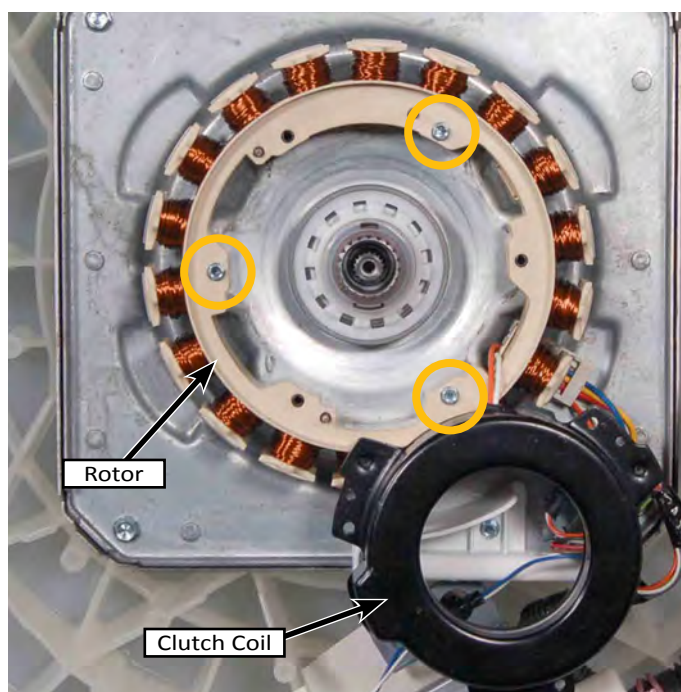

Figure 3

Removing the Motor and Drive Assembly (continued)

Removing the Clutch (Slider) Assembly

- Figure 1 shows the three parts of the Clutch Assembly; the spiral retaining ring, the clutch spring, and the clutch (slider). The first step in removing the clutch assembly is to remove the spiral retaining ring. Locate the overlap of the spiral ring and use a small flat blade screwdriver to pry ring off of shaft.

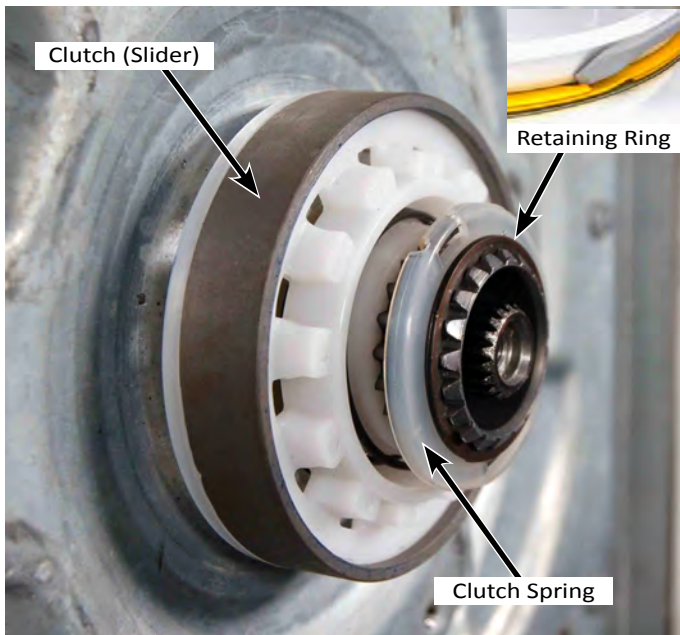

Figure 1

- Next, remove the Clutch Spring, and then the Clutch (Slider).

Removing the Drive Assembly

- Use a 1/4" socket to remove the hex-head screw securing the ground wire to the drive assembly.
- Use a 10mm socket to remove the four (4) screws securing the drive assembly to the tub. (The bottom right screw also secures the connector clip to the drive assembly.) The drive assembly can now be pulled away from the tub.

NOTE: If the drive assembly cannot easily be pulled from the tub, it may be necessary to tap on the drive assembly from inside the tub to loosen the drive from the tub.

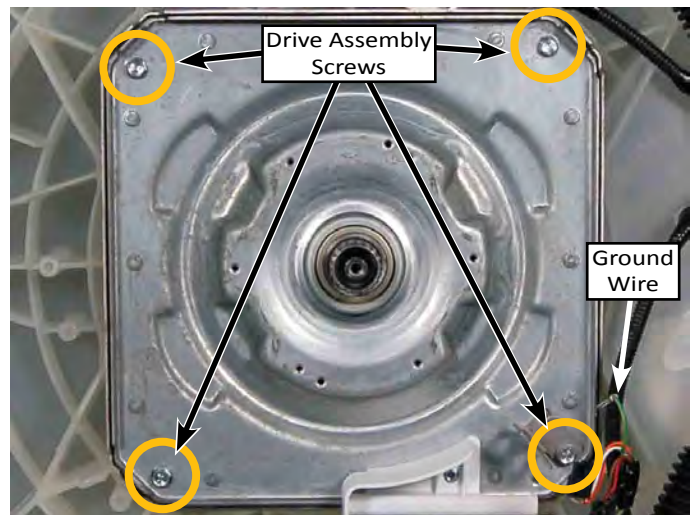

Figure 2

IMPORTANT REASSEMBLY NOTES

REASSEMBLY NOTE: When you reinstall the rotor over the stator assembly, do not grip the rotor housing around the rear edge with your fingers. The magnets around the rotor housing are very strong, and they will pull the rotor into the stator coil magnets when the rotor magnets come within their magnetic field. Keep your fingers along the outside of the rotor housing and away from the rear edge when you are installing it on the stator assembly.

REASSEMBLY NOTE: Any time the rotor bolt is removed, Loctite® adhesive (Threadlocker Blue 242® or similar adhesive) must be reapplied, otherwise the bolt will eventually work itself loose resulting in a second call.



REASSEMBLY NOTE: The four (4) drive assembly screws are threaded into the bottom of the plastic tub (see Figure 2 above). Using a power driver to tighten the screws may strip the holes. Tighten only by hand until very snug.

REASSEMBLY NOTE: The harness guide routes the harness away from moving drive components (rotor). Be sure to reinstall the guide anytime it is removed.

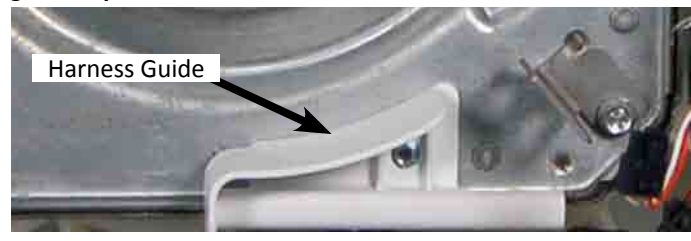



Removing the Pumps

⚠ WARNING



Electrical Shock Hazard
 Disconnect power before servicing.
 Replace all parts and panels before operating.
 Failure to do so can result in death or electrical shock.

Preparation

1. Unplug washer or disconnect power.
2. Turn off water supply to washer.
3. Disconnect hot and cold inlet water hoses and remove the drain hose from the standpipe or laundry tub.
4. Tape the washer lid closed.
5. Carefully lay the washer on its back panel. Place padding on the floor to protect the surfaces.
6. Remove sound padding and set aside.

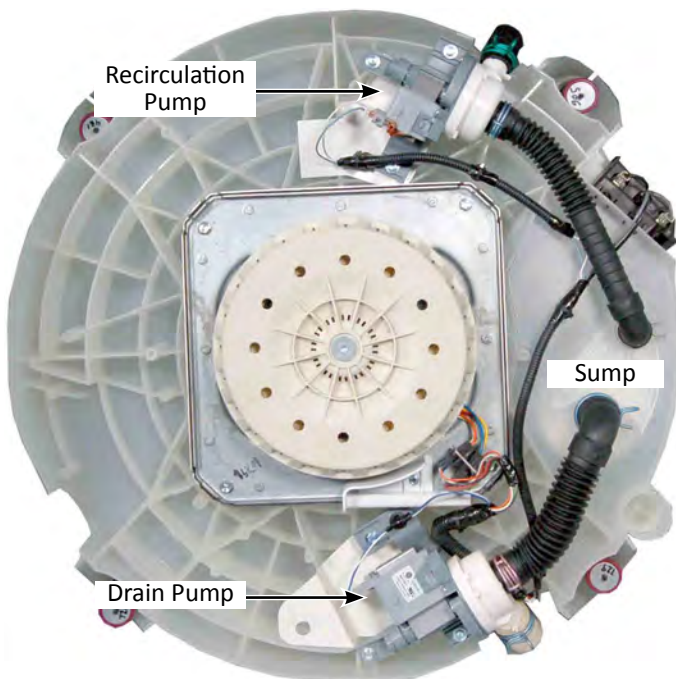

Figure 1

Removing the Drain Pump (Figure 2)

1. Disconnect harness (2 terminals) from drain pump.
2. Loosen the hose clamps and pull the inlet and outlet drain hoses off the pump. Note that there is a tab on the outlet connector that fits into a slot in the hose.
3. Remove the three (3) 8mm hex-head screws from the drain pump and remove the pump from the tub.

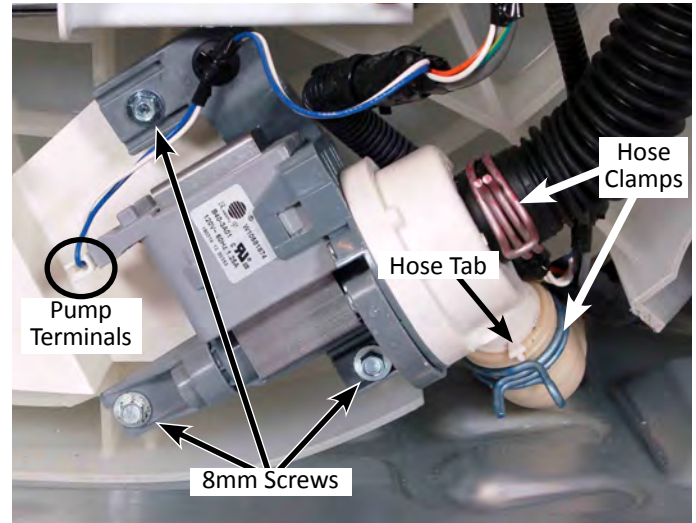

Figure 2

Removing the Recirculation Pump (Figure 3)

1. Disconnect harness (2 terminals) from recirculation pump.
2. Loosen the hose clamps and pull the inlet and outlet drain hoses off the pump. Note that there is a tab on the outlet connector that fits into a slot in the hose.
3. Remove the three (3) 8mm hex-head screws from the drain pump and remove the pump from the tub.

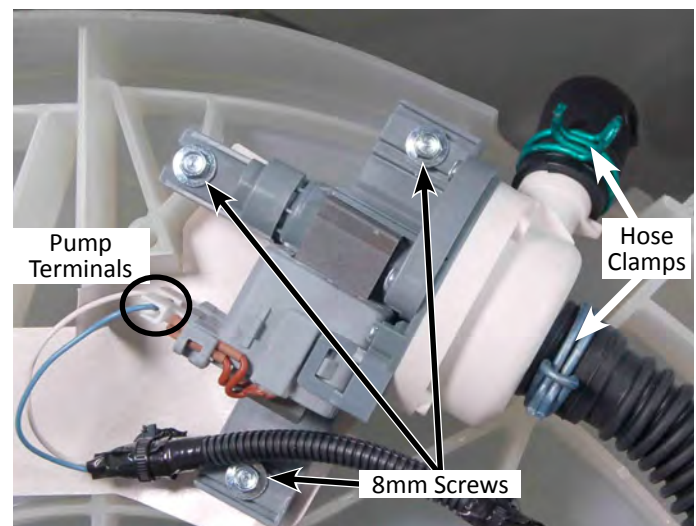

Figure 3



Removing the Heater

⚠ WARNING



Electrical Shock Hazard
 Disconnect power before servicing.
 Replace all parts and panels before operating.
 Failure to do so can result in death or electrical shock.

Preparation

1. Unplug washer or disconnect power.
2. Turn off water supply to washer.
3. Disconnect hot and cold inlet water hoses and remove the drain hose from the standpipe or laundry tub.
4. Tape the washer lid closed.
5. Carefully lay the washer on its back panel. Place padding on the floor to protect the surfaces.
6. Remove sound padding and set aside.

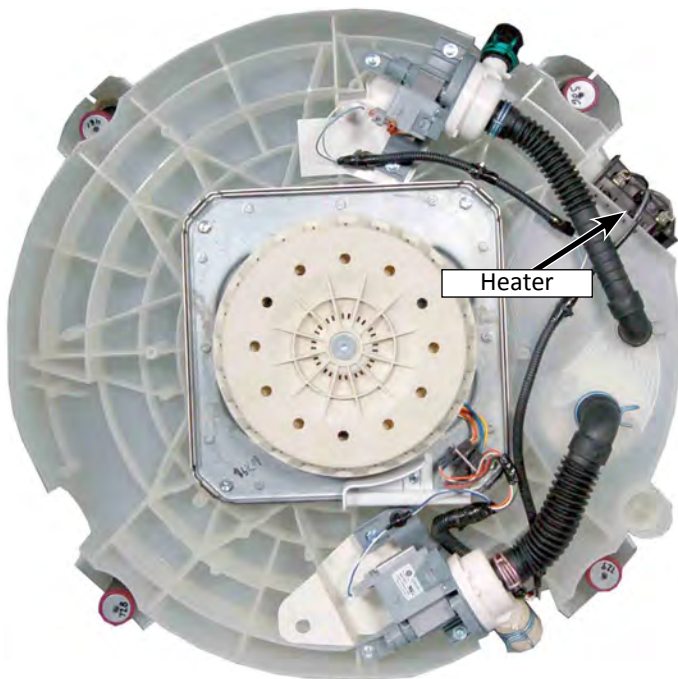

Figure 1

Removing the Heater

1. Disconnect harness (2 terminals) from the Heater Assembly (see Figure 2).
2. Remove the 8mm hex-head screw securing the heater cover to the tub. Remove heater cover from washer (see Figure 2).

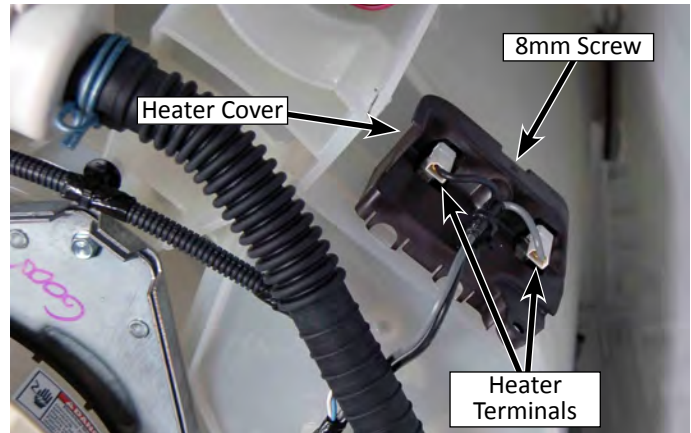

Figure 2

3. Use a 10mm socket to loosen the nut securing heater element to tub. When the heater gasket has decompressed sufficiently, remove the element from tub assembly (see Figure 3).

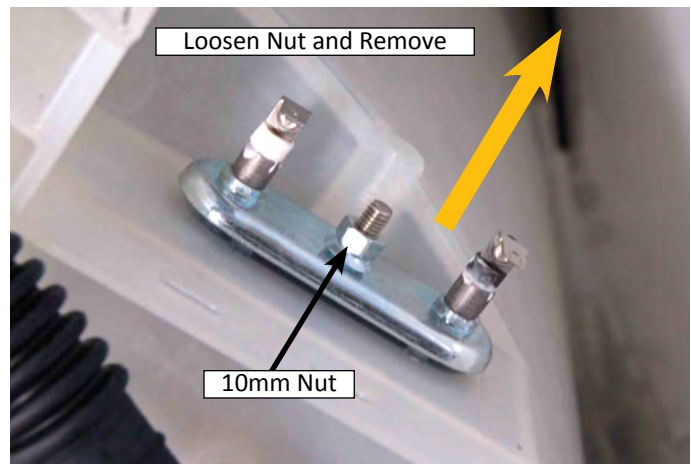

Figure 3

Heater Element

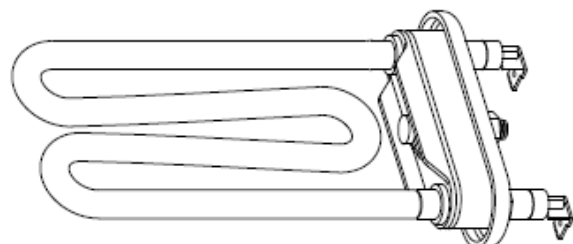

Figure 4



Removing the Lid Lock

⚠ WARNING



Electrical Shock Hazard
 Disconnect power before servicing.
 Replace all parts and panels before operating.
 Failure to do so can result in death or electrical shock.

7. Perform the procedures on page 4-8, "Lifting the Top Panel" prior to performing the following steps.
8. Remove the Lid Lock harness from the clips on right side of top panel.
9. Remove the two Phillips screws (circled) securing the lid lock assembly to the lid (see Figure 2). Lift the lid lock assembly up and away from the lock adapter (see Figure 2).

Removing the Lid Lock

1. Unplug washer or disconnect power.
2. Turn off water supply to washer.
3. Disconnect hot and cold inlet water hoses.
4. Perform the procedures on pages 4-3 or 4-4, "Removing the Console" prior to performing the following steps.
5. Disconnect the Lid Lock connector "J6" from the Main Control (see Figure 1).
6. Feed the Lid Lock harness through the opening in the washer top panel (see Figure 1).

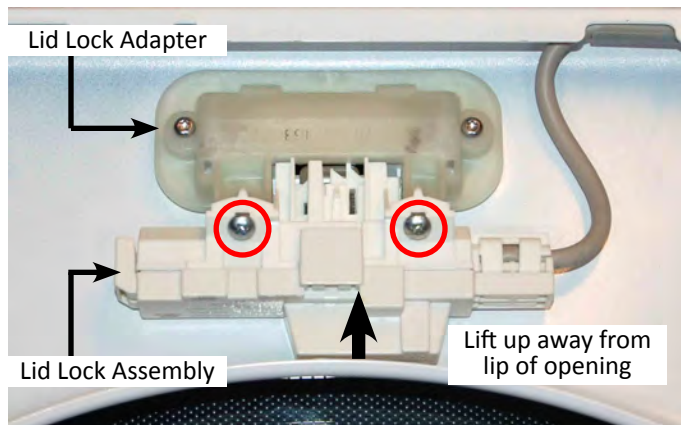

Figure 2

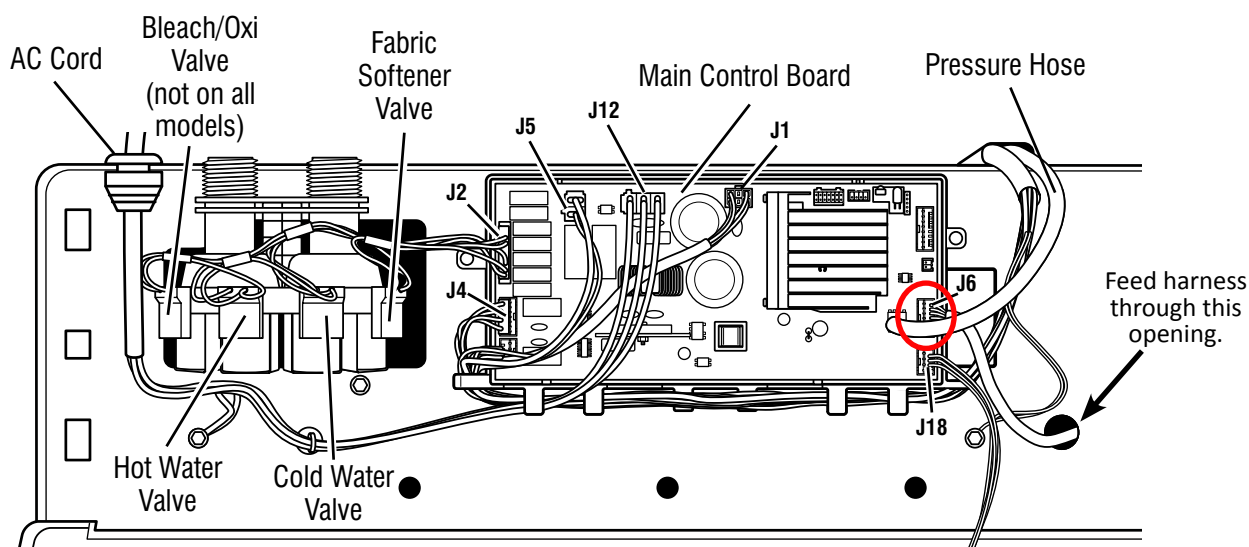

Figure 1



Removing the Lid and a Hinge

⚠ WARNING



Electrical Shock Hazard
 Disconnect power before servicing.
 Replace all parts and panels before operating.
 Failure to do so can result in death or electrical shock.

To Remove the Lid

1. Unplug washer or disconnect power.
2. Raise the lid and remove the two hinge pin screws from both sides using a T15 TORX driver (see Figure 1).

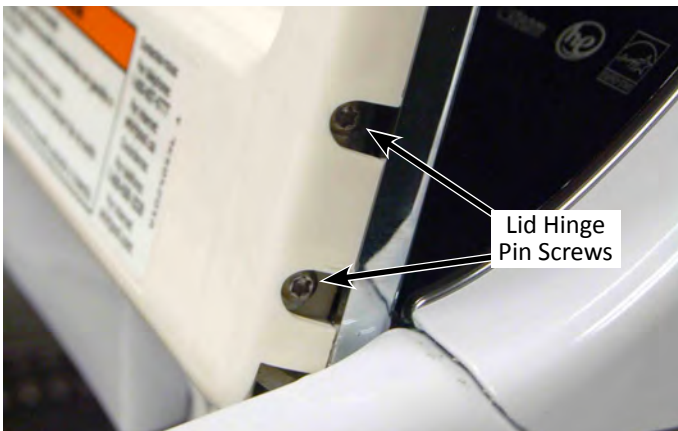

Figure 1

3. Slide the lid off the hinge pins, and remove lid from the washer (see Figure 2).



Figure 2

To Remove a Hinge

1. Perform the steps under "To Remove the Lid."
2. Pull the hinge pin out of the hinge you are removing (see Figure 3).
3. If not already, remove the console per directions earlier in this section on pages 4-3 and 4-4.
4. Remove the Phillips screw from the hinge you are removing (see Figure 3).

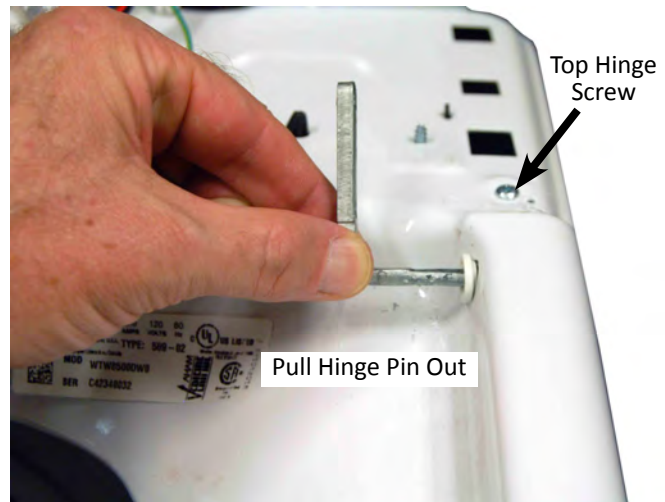

Figure 3

5. Perform the procedures on page 4-8, "Lifting the Top Panel" prior to performing the following step.
6. Remove the 1/4" hex-head screw from the hinge mounting bracket, and remove the hinge from the cabinet top (see Figure 4).

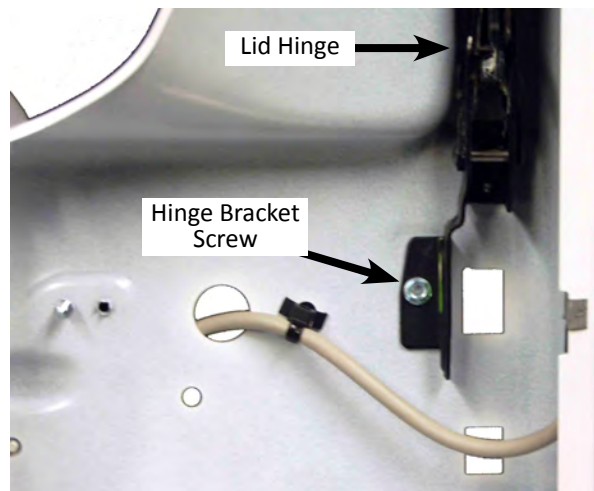

Figure 4

Section 5: Diagnostics & Troubleshooting

This section provides diagnostic, fault codes, and troubleshooting information for the “Whirlpool 2014 CABRIO® Top Load Direct Drive Washer.”

- Diagnostics & Troubleshooting: Safety Information
- Diagnostic Guide
- Diagnostic LED - Main Control
- Self Diagnostic Mode
- Activating Service Diagnostic Mode
- Key Activation & Encoder Test
- Service Test Mode
- Load & Test Cycle Functions Numbers Chart
- Service Diagnostic Execution
- Service Diagnostic Chart
- Software Version Display
- Fault/Error Codes
- Exiting Service Diagnostic Mode
- Troubleshooting Guide
- Notes

For Service Technician Use Only

⚠ DANGER



Electrical Shock Hazard

Only authorized technicians should perform diagnostic voltage measurements.

After performing voltage measurements, disconnect power before servicing.

Failure to follow these instructions can result in death or electrical shock.

⚠ WARNING



Electrical Shock Hazard

Disconnect power before servicing.

Replace all parts and panels before operating.

Failure to do so can result in death or electrical shock.

Voltage Measurement Safety Information

When performing live voltage measurements, you must do the following:

- Verify the controls are in the off position so that the appliance does not start when energized.
- Allow enough space to perform the voltage measurements without obstructions.
- Keep other people a safe distance away from the appliance to prevent potential injury.
- Always use the proper testing equipment.
- After voltage measurements, always disconnect power before servicing.

IMPORTANT: Electrostatic Discharge (ESD) Sensitive Electronics

ESD problems are present everywhere. Most people begin to feel an ESD discharge at approximately 3000V. It takes as little as 10V to destroy, damage, or weaken the main control assembly. The new main control assembly may appear to work well after repair is finished, but a malfunction may occur at a later date due to ESD stress.

- Use an anti-static wrist strap. Connect wrist strap to green ground connection point or unpainted metal in the appliance

-OR-

- Touch your finger repeatedly to a green ground connection point or unpainted metal in the appliance.
- Before removing the part from its package, touch the anti-static bag to a green ground connection point or unpainted metal in the appliance.
- Avoid touching electronic parts or terminal contacts; handle electronic control assembly by edges only.
- When repackaging main control assembly in anti-static bag, observe above instructions.

IMPORTANT SAFETY NOTICE — “For Technicians only”

This service data sheet is intended for use by persons having electrical, electronic, and mechanical experience and knowledge at a level generally considered acceptable in the appliance repair trade. Any attempt to repair a major appliance may result in personal injury and property damage. The manufacturer or seller cannot be responsible, nor assume any liability for injury or damage of any kind arising from the use of this data sheet.

For Service Technician Use Only

Diagnostic Guide

Before servicing, check the following:

- Make sure there is power at the wall outlet.
- Has a household fuse blown or circuit breaker tripped? Was a regular fuse used? Inform customer that a time-delay fuse is required.
- Are both hot and cold water faucets open and water supply hoses unobstructed?
- Make sure drain hose is not sealed into drain pipe, and that there is an air gap for ventilation. Ensure drain height is between 39" (991 mm) and 8' (2.4 m) above the floor.
- All tests/checks should be made with a VOM (volt-ohm-milliammeter) or DVM (digital-voltmeter) having a sensitivity of 20,000 Ω per volt DC or greater.
- Resistance checks must be made with washer unplugged or power disconnected.
- **IMPORTANT:** Avoid using large diameter probes when checking harness connectors as the probes may damage the connectors upon insertion.
- Check all harnesses and connections before replacing components. Look for connectors not fully seated, broken or loose wires and terminals, or wires not pressed into connectors far enough to engage metal barbs.
- A potential cause of a control not functioning is corrosion or contamination on connections. Use an ohmmeter to check for continuity across suspected connections.

Diagnostic LED – Main Control

A troubleshooting tool has been implemented onto the main control board—a diagnostic LED (see Figure 1). **LED Flashing** – The Control is detecting correct incoming line voltage and the processor is functioning. **LED OFF or ON** – Control malfunction. Perform TEST #1: Main Control, page 6-5, to verify main control functionality.

Self Diagnostic Mode

These tests allow factory or service personnel to test and verify all inputs to the main control board. You may want to do a quick and overall checkup of the washer with these tests before going to specific troubleshooting tests.

ACTIVATING SERVICE DIAGNOSTIC MODE

1. Be sure the washer is in standby mode (plugged in with all indicators off).
2. Select any three (3) buttons (except POWER) and follow the steps below, using the same buttons (remember the buttons and the order that the buttons were pressed):

Within 8 seconds,

- Press and Release the **1st** selected button,
 - Press and Release the **2nd** selected button,
 - Press and Release the **3rd** selected button;
 - Repeat this 3 button sequence 2 more times.
3. If this test mode has been entered successfully, all indicators on the console will be illuminated for 5 seconds with "888" showing in the three-digit display and a tone will sound. If there are no saved fault codes, all indicators on the console will momentarily turn off, and then only the seven segment display will come back on and display "888". Upon entry to Service Diagnostic mode, all cycles and options reset to factory default.

NOTE: The Service Diagnostic mode will time out after 5–10 minutes of user inactivity, or shut down if AC power is removed from the washer.

Unsuccessful Activation

If entry into diagnostic mode is unsuccessful, refer to the following indication and action:

Indication: None of the indicators or display turn on.

Action: Select any cycle.

- If indicators come on, try to change the function for the three buttons used to activate the diagnostic test mode. If any button is unable to change the function, something is faulty with the button, and it will not be possible to enter the diagnostic mode using that button. Replace the user interface.
- If no indicators come on after selecting the cycle, go to TEST #1: Main Control, page 6-5.

Activation with Saved Fault Codes

If there is a saved fault code, it will be flashing in the display. Review the Fault/Error Codes table on pages 5-9 to 5-11 for the recommended procedure. If there is no saved fault code, "888" will be displayed.

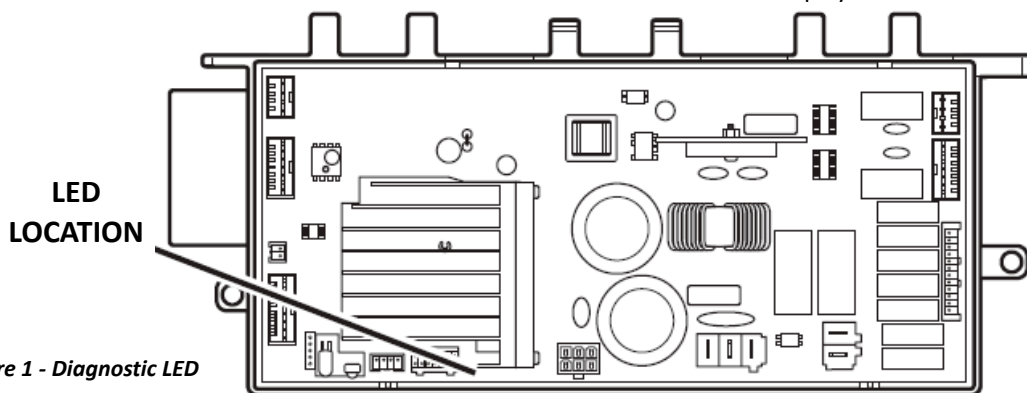

Figure 1 - Diagnostic LED

For Service Technician Use Only

SERVICE DIAGNOSTIC MENU TABLE		
	Button Press	Function Behavior
1st Button	- Momentary press	- Activates Key Activation & Encoder Test
	- Press and hold for 5 secs.	- Exits Service Diagnostics
2nd Button	- Momentary press	- Activates Service Test Mode
	- Press and hold for 5 secs.	- Software Version Display
3rd Button	- Momentary press	- Displays Next Error Code
	- Press and hold for 5 secs.	- Clears the Error Codes

See “Activating Service Diagnostic Mode” to activate these buttons. Make sure all of step 3 is complete before activation.

Key Activation & Encoder Test

NOTE: The Service Diagnostic mode must be activated before entering the Key Activation & Encoder Test; see procedure on page 5-3.

Entry Procedure

Press and release the **1st** button used to activate Service Diagnostic mode. The following test will be available:

DIAGNOSTIC: Key Activation & Encoder Test

Pressing each button will turn off its corresponding indicator(s) or display segment and sound a beep.

Rotating the cycle selector knob (on some models) turns off each corresponding cycle indicator and sounds a beep.

NOTE: A second press of the **POWER** button while in Key Activation & Encoder Test or pressing and holding the **1st** button used to enter Service Diagnostic mode exits the Service Diagnostic mode and returns the washer to standby mode.

Service Test Mode

NOTE: The Service Diagnostic mode must be activated before entering Service Test Mode; see procedure on page 5-3.

NOTE: If, at any point, the user presses the **POWER** button during Service Test Mode, the washer exits to standby mode.

Active Fault Code Display in Service Test Mode

If the display begins flashing while in Service Test Mode, it is displaying an active fault code. Active fault codes are codes that are currently detected. Only one active fault code can be displayed at a time.

Entry Procedure

To enter Service Test Mode, press and release the **2nd** button used to activate the Service Diagnostic mode.

Successful Entry

All LEDs turn off except the **POWER** button indicator and the **START** button indicator begins to flash.

Service Test Load Control and Service Cycle Modes

Test Load Selection Procedure

To select Load or Service Diagnostics, use the Soil Level and Temp buttons or cycle selection knob, if available. Soil Level will increment through the loads and Temp will decrement through the available functions.

Rotating the cycle selection knob clockwise will increment the selected function while rotating counterclockwise will decrement through the available functions.

Load Control Status Indication

The Estimated Time Remaining (ETR) display will indicate the current selected load or function. If the selected load is currently active (commanded on), the ETR display will flash the load number at a 1Hz rate. If the load is currently commanded off, the ETR display will show the load number without flashing.

Commanding Loads ‘On’ and ‘Off’ in Service Test Mode

With the desired load’s number on the ETR display, the load can be toggled on and off by pressing the **START** button. Each press will toggle the state of the load from ‘off’ to ‘on’ or from ‘on’ to ‘off’. NOTE: Activating any of the spin or agitate functions will result in functions 10–14 reporting their status as ‘on’ because reported status is based on motor motion being commanded.

Failure to Turn Load On Indication

If the number of loads (pumps, valves, and motor) allowed on at the same time or the conditions to actuate the load are not correct, the display will turn off momentarily and an invalid tone will sound.

The chart below indicates load and test cycle function numbers:

For Service Technician Use Only

Load and Test Cycle Function Numbers Chart

NOTE: Some loads will not be available on all models

Display	Function	Notes
000	Toggle Lid Lock	Note: To lock or unlock the lid, all loads (pumps, motor, valves, and heater) must be off and the lid must be closed.
001	Toggle Cold Valve	
002	Toggle Hot Valve	
003	Toggle Fresh Fill Valve	N/A
004	Toggle Detergent Valve	N/A
005	Toggle Fabric Softener Valve	For water to flow, cold water should be turned on first. Note: If the fabric softener valve is turned "ON" without the cold water valve "ON", water can overflow the front of the tray.
006	Toggle Oxi Valve	For water to flow, hot water should be turned on first. Note: If the Oxi valve is turned "ON" without the hot water valve "ON", water can overflow the front of the tray. Note: Oxi not available on all models.
007	Toggle Bleach Valve	Note: On models with dump bleach dispenser, toggling this load will turn on the Oxi valve.
008	Toggle Drain Pump	
009	Toggle Recirc. Pump	Note: Not available on all models.
010	Toggle Low Speed Spin	Lid must be closed and locked for this to be enabled. Note: The basket must be empty for this function.
011	Toggle Mid Speed Spin	Lid must be closed and locked for this to be enabled. Note: The basket must be empty for this function.
012	Toggle High Speed Spin	Lid must be closed and locked for this to be enabled. Note: The basket must be empty for this function.
013	Toggle Slow Agitate	Lid must be closed and locked for this to be enabled. Note: The basket must be empty for this function.
014	Toggle Fast Agitate	Lid must be closed and locked for this to be enabled. Note: The basket must be empty for this function.
015	Toggle Shifter	Switch in and out of Spin. Shifter On = Spin and Shifter Off = Agitate. Note: This can only be commanded while the motor is not running. The shifter will also be on when spin functions 10–12 are active.
016	Toggle Basket Light	N/A
017	Toggle Heater	Note: To actuate the heater, all loads (pumps, motor, and valves) must be off and water level must be above the impeller.
050	Run Factory Calibration	Note: For factory test only.
051	Service Diagnostics	Service Diagnostics for repair verification and installation verification.
052	Run Service Calibration	This calibrates the main control to the washer for optimal load size sensing. Upon completion, the UI will display 000. The Soil Level and Temp buttons can be used to review step results if Pass/Fail criteria exist. If a step has no Pass/Fail criteria, --- will be displayed.
053	Run Dry Factory Calibration	Note: For factory test only.
075	Set Life Test Mode	Note: For factory test only. If life test mode is accidentally activated, Life Test can be exited by removing power from the washer and waiting for the control to power down as indicated by the diagnostic LED ceasing to flash (5-3).

For Service Technician Use Only

Service Diagnostics Execution

When Service Diagnostics is activated, any load(s) that were manually commanded on will be turned off. Service Diagnostics will start and the step number within the Service Diagnostics sequence will be shown on the display. **NOTE:** The basket must be empty during this test.

Service Diagnostic Chart

Display	Washer Function	Recommended Procedure	Est. Time in Seconds
001	Warm water fills through the Detergent valve	If not water, use service test load control to manually turn on and test the valve.	10
002	Cold water fills through the Fabric Softener valve	If not water, use service test load control to manually turn on and test the valve.	10
003	Hot water fills through the Bleach/Oxi valve*	If not water, use service test load control to manually turn on and test the valve.	10
004	Warm water fills through the detergent valve to minimum water level	If not water, use service test load control to manually turn on and test the valve.	50-70
005	Validates pressure sensor	If this step fails, replace the appliance control unit.	Up to 5
006	Validates inlet thermistor	If this step fails, go to and complete the Temperature Thermistor test.	Up to 5
007	Validates IPM thermistor	If this step fails, replace the appliance control unit.	Up to 5
008	Turns on heater*	If heater does not turn on, use service test load control to manually turn on and test the heater.	8
009	Recirculates* for 10 seconds	If water is not being recirculated, use service test load control to test the recirculation pump.	10
010	Skip	N/A	---
011	Lid will lock	Lid must be closed. If lid does not lock, use service test load control to manually test the lid lock.	10
012	Skip	N/A	---
013	Drain pump on for 15 seconds	If water is not draining, use service test load control to test the drain pump.	20

* On models without bleach/oxi valve, heater, and/or recirculation pump, steps 3, 8, and 9 will be skipped.

For Service Technician Use Only

Service Diagnostic Chart (continued)

Display	Washer Function	Recommended Procedure	Est. Time in Seconds
014	Drain pump and recirculation pump† on for 25-30 seconds	If water is not being drained or recirculated, use service test load controls to test the drain pump.	<10
015	Pause	N/A	5
016	Agitate for 5 seconds	Use service test load control to manually test the motor.	5
017	Low speed spin for 5 seconds	Use service test load control to manually test the motor.	5
018	Spin for 20-30 seconds	Use service test load control to manually test the motor.	30-40
019	Agitate for 10 seconds	Use service test load control to manually test the motor.	10
020	Unlock lid	If lid does not unlock, use service test load control to manually test the lid lock.	5
Total time in minutes			Appx. 3-4 mins.

†On models without recirculation pump, only the drain pump will turn on in step 14.

Service Diagnostics Pass/Fail Indication

After the cycle completes, the Pass or Failure status of each step in Service Diagnostics is available by the following procedures:

Models without a cycle selection knob

Press the soil level or temp buttons. The sequence step increments using the soil level button and decrements using the temp button.

Models with a cycle selection knob

In addition to pressing the soil level or temp buttons, rotating the cycle selection knob clockwise increments through the cycle functions while rotating counterclockwise decrements through the available options.

On all models, the display will flash between the sequence function number and "PAS" for Pass, "FAL" for Fail, or "---" if the machine control is not capable of determining if a function passed or failed; each will be displayed for 1 second.

Exiting Service Diagnostics Mode

Press the POWER button. All loads will be turned off and the washer will enter standby.

Fault Detection During Service Diagnostics Execution

Some faults will stop the cycle execution (see Fault And Error Codes charts on pages 5-9 to 5-11 for those faults [marked with ‡] that stop the washer). If a fault is detected, the washer will stop executing the cycle and the step during which the fault was encountered will remain on the display. If no action is taken within 5–10 minutes, the display will be cleared and the washer will enter standby mode.

For Service Technician Use Only

Software Version Display

NOTE: The Software Version Display mode will time out after 5–10 minutes of user inactivity and return to standby mode.

Entry Procedure

To enter Software Version Display, press and **hold** the **2nd** button used to activate the Service Diagnostic mode for 5 seconds. Upon entry, all LEDs on the console will turn off, then the display will automatically cycle through the following information:

- UI software revision code (U major revision number, U minor revision number, U test revision number)
- UI cycle GEE software revision code (y major revision number, y minor revision number, y test revision number)
- UI HW GEE file software revision code (H major revision number, H minor revision number, H test revision number)
- UI touch EEPROM revision code (o major revision number, o minor revision number, o test revision number)
- UI touch control software revision code (t major revision number, t minor revision number, t test revision number)
- UI audio software revision code (A major revision number, A minor revision number, A test revision number)
- ACU software revision code (C major revision number, C minor revision number, C test revision number)
- ACU GEE file revision code (h major revision number, h minor revision number, h test revision number)
- MCU software file revision code (n major revision number, n minor revision number, n test revision number)
- Cycle design revision code (d major revision number, d minor revision number, d test revision number)

Exit Procedure

Pressing the **POWER** button will exit Software Version Display and return washer to standby mode.

Fault/Error Codes

Refer to Fault/Error Codes chart on pages 5-9 to 5-11.

Fault/Error Code Display Method

Fault codes are displayed by alternately showing F# and E#. All fault codes have an F# and an E#. The F# indicates the suspect System/Category. The E# indicates the suspect Component system.

Up to four Fault/Error codes may be stored. When the oldest fault code is displayed, additional presses of the 3rd button will result in a triple beep, then display of the most recent fault code. If each press of the 3rd button results in a triple beep and the display shows “888”, no saved fault codes are present.

Advancing Through Saved Fault/Error Codes

Procedure for advancing through saved fault codes:

Press and release the 3rd button used to activate Service Diagnostics	⇒ beep tone ⇒	most recent fault code is displayed
Repeat	⇒ beep tone ⇒	second most recent fault code is displayed
Repeat	⇒ beep tone ⇒	third most recent fault code is displayed
Repeat	⇒ beep tone ⇒	fourth most recent fault code is displayed
Repeat	⇒ beep tone ⇒	back to the most recent fault code

Clearing Fault Codes

To clear stored fault codes, enter Service Diagnostic mode. Then press and hold the 3rd button used to enter Service Diagnostic mode for 5 seconds. Once the stored fault codes are successfully erased, the seven segment display will show “888”.

EXITING SERVICE DIAGNOSTIC MODE

Use either of the two methods below to exit diagnostic mode.

- Pressing and holding the 1st button used to activate the Service Diagnostic mode for 5 seconds.
- Pressing the **POWER** button once or twice, depending on diagnostic procedure.

For Service Technician Use Only

Fault and Error Codes

Code	Description	Explanation and Recommended Procedure
FOE2	Oversuds	Fault is displayed when suds prevent the basket from spinning up to speed or the pressure sensor detects rising suds level. The main control will flush water in an attempt to clear suds. If the water flush is unable to correct the problem, this may indicate: <ul style="list-style-type: none"> • Not using HE detergent. • Excessive detergent usage. • Check pressure hose connection from tub to main control. Is hose pinched, kinked, plugged, or leaking air? • Mechanical friction on drive mechanism or basket (items between basket and tub).
FOE3	Overload	Fault is displayed when the main control detects a load size that exceeds the washer's capacity OR basket cannot be turned. This may signify: <ul style="list-style-type: none"> • Load size exceeds washer capacity. Remove excess laundry, then restart the cycle. • Mechanical friction on drive mechanism or basket (items between basket and tub).
FOE4	Spin Limited by Water Temperature	Fault is displayed when the water temperature is too high to have spin at final speed. Speed will be limited to 500 rpm. <ul style="list-style-type: none"> • Check water valve function. See TEST #2: Valves, page 6-7.
FOE5	Off Balance Load	Fault is displayed when an off balance condition is detected. <ul style="list-style-type: none"> • Check for weak suspension. Basket should not bounce up and down more than once when pushed. • Items should be distributed evenly when loading.
F1E1‡	Main Control Fault	Indicates a main control fault. <ul style="list-style-type: none"> • See TEST #1: Main Control, page 6-5.
F1E2‡	Main Control Fault	Indicates a fault of the motor control section of the main control. <ul style="list-style-type: none"> • See TEST #3b: Drive System – Motor, page 6-10.
F1E3‡	Mismatch of ACU and UI	This fault is displayed when the user interface identification does not match the expected value in the Main Control Board. <ul style="list-style-type: none"> • Fault occurs during Diagnostic Test Mode if a mismatch of main control and UI is identified. • See Key Activation & Encoder Test, page 5-4.
F2E1	UI Stuck Button	Indicates that the user interface is detecting that a button is continuously activated. <ul style="list-style-type: none"> • See Key Activation & Encoder Test, page 5-4.
F2E3	UI Mismatch	Indicates that the machine control or user interface ID do not match the expected values. <ul style="list-style-type: none"> • Verify that the ACU and UI part numbers are correct.
F2E4	UI Software Error: Incompatible Parameter File	Indicates that a parameter file in the UI is not correct. <ul style="list-style-type: none"> • Replace the user interface.
F2E5	UI Software Error: Parameter Memory Invalid	Indicates that a parameter file in the UI is corrupt. <ul style="list-style-type: none"> • Replace the user interface.
F3E1‡	Pressure System Fault	Fault is displayed when the main control detects an out of range pressure signal. <ul style="list-style-type: none"> • Check pressure hose connection from tub to main control. Is hose pinched, kinked, plugged, or leaking air? • See TEST #6: Water Level, page 6-13.
F3E2	Inlet Water Temperature Fault	Fault is displayed when the inlet thermistor is detected to be open or shorted. <ul style="list-style-type: none"> • See TEST #5: Temperature Thermistor, page 6-12.

‡This fault will stop the washer during Service Diagnostics.

For Service Technician Use Only

Fault and Error Codes (continued)

Code	Description	Explanation and Recommended Procedure
F4E1	Heater Stuck On	Fault is displayed when the heater is ON when it should be OFF. <ul style="list-style-type: none"> • See TEST #9: Heater Element, page 6-16.
F4E2	Heater Not Turning On	Fault is displayed when the heater has been turned ON by the control, but the control cannot detect that the heater is ON. <ul style="list-style-type: none"> • See TEST #9: Heater Element, page 6-16.
F5E1	Lid Switch Fault - Lid Is Up	Fault is displayed if lid is in locked state, but lid switch is open; control not sensing the strike in the lid lock. <ul style="list-style-type: none"> • User presses START with lid open. • The main control cannot detect the lid switch opening and closing properly. • See TEST #8: Lid Lock, page 6-15.
F5E2	Lid Lock Will Not Lock Or Lid Lock Failure	Fault is displayed if any of the following conditions occur: <ul style="list-style-type: none"> • Lid is not closed completely due to interference. • Check for lock interference with lid or lock bezel. • Wash media buildup is preventing the lock bolt from extending. • Main control detects open lid switch when attempting to lock. • Main control cannot determine if lid lock is in a locked state. • See TEST #8: Lid Lock, page 6-15.
F5E3	Lid Lock Will No Unlock	Fault is displayed when one of the following conditions occurs: <ul style="list-style-type: none"> • Excessive force on lid is preventing lock bolt from retracting. • Wash media buildup is preventing lock bolt from retracting. • Main control cannot determine if lid lock is in an unlocked state. • See TEST #8: Lid Lock, page 6-15.
F5E4	Lid Not Opened Between Cycles	Fault is displayed when one of the following conditions occurs: <ul style="list-style-type: none"> • User presses START with lid open. • User presses START after a predetermined number of consecutive washer cycles without opening lid. • The main control cannot detect the lid switch opening and closing properly. • See TEST #8: Lid Lock, page 6-15.
F6E2	Communication Error: UI Cannot Hear ACU	Fault is displayed when communication between the UI and the ACU has not been detected. <ul style="list-style-type: none"> • Check continuity in the UI harness. • Complete Test #1: Main Control, page 6-5 and Test #4: Keys and Encoders, page 6-11.
F6E3	Communication Error: ACU Cannot Hear UI	
F7E0	Loss Of Power	Fault is displayed when the main control detects control voltage is too low or lost. <ul style="list-style-type: none"> • Check power at outlet. • Check circuit breakers, fuses, or junction box connections. • Check AC power cord for continuity. • See TEST #1: Main Control, page 6-5.
F7E1	Loss of Power During Spin	Fault is displayed when power is lost during spin. This fault forces the washer to pause for 5 minutes to allow the basket to stop before continuing the cycle. <ul style="list-style-type: none"> • See F7E0 recommendations above.
F7E2	Motor Drive Module Failure	Fault is displayed when the main control detects a problem in the motor drive. See TEST #3b: Drive System – Motor, page 6-10.
F7E3	Basket Engaged During Wash	Fault is displayed when the main control determines the shifter is not engaging the basket for spin or disengaging it for wash. <ul style="list-style-type: none"> • Check shifter connectors. • Check for clothing or another item wedged between the impeller and the basket that could bind them together. • Check that the shifter slider moves freely. • See TEST #3a: Drive System – Shifter, page 6-8.
F7E4	Basket Re-engagement Failure	
F7E5	Shifter Failure	
F7E6	Motor Circuit Open	Fault is displayed when main control detects one or more of the motor lines is open. <ul style="list-style-type: none"> • Check motor circuit. • See TEST #3: Drive System, page 6-8 or TEST #3b: Drive System – Motor, page 6-10.

For Service Technician Use Only

Fault and Error Codes (continued)

Code	Description	Explanation and Recommended Procedure
F7E7	Motor Unable to Meet Target RPM	<p>Fault is displayed when the main control is unable to get to the commanded motor speed.</p> <ul style="list-style-type: none"> Mechanical friction on drive mechanism or basket (items between basket and tub). Load off balance. Items should be distributed evenly when loading. See TEST #3: Drive System, page 6-8 or TEST #3b: Drive System – Motor, page 6-10.
F7E8	Motor Over Temperature	<p>Fault is displayed when the main control determines the motor temperature is too high.</p> <ul style="list-style-type: none"> Perform service calibration to calibrate water level and load size detection. Mechanical friction on drive mechanism or basket (items between basket and tub).
F7E9	Locked Rotor	<p>Fault is displayed when the main control determines that the motor is not moving when it is being actively driven.</p> <ul style="list-style-type: none"> Mechanical friction on drive mechanism or basket (items between basket and tub). See TEST #3: Drive System, page 6-8 or TEST #3b: Drive System – Motor, page 6-10.
“LF” or F8E1‡	Long Fill	<p>Fault is displayed when the water level does not change for a period of time OR water is present but the control does not detect the water level changing.</p> <ul style="list-style-type: none"> Is water supply connected and turned on? Are hose screens plugged? Is water siphoning out of the drain hose? Check for proper drain hose installation. Low water pressure; fill times longer than 10 minutes. Is the pressure hose connection from the tub to the main control pinched, kinked, plugged, or leaking air? See TEST #2: Valves, page 6-7.
F8E3	Overflow or Flood Condition	<p>Fault is displayed when main control senses water level that exceeds washer capacity.</p> <ul style="list-style-type: none"> Check pressure hose connection from tub to main control. Is hose pinched, kinked, plugged, or leaking air? Check for proper drain hose installation. Is water siphoning out of the drain hose? Drain hose must not be more than 4.5” (114 mm) into the drain pipe. Make sure drain hose is not sealed into drain pipe, and that there is an air gap for ventilation. Ensure that drain height is between 39” (991 mm) and 8’ (2.4 m) above the floor. May signify problem with water inlet valves. Pressure transducer fault on main control. See TEST #2: Valves, page 6-7 and TEST #6: Water Level, page 6-13.
F8E6	Water Hazard	<p>Fault is displayed when main control senses water in the tub and the lid has been left open for more than 10 minutes.</p> <ul style="list-style-type: none"> Check pressure hose connection from tub to main control. Is hose pinched, kinked, plugged, or leaking air? Check for proper drain hose installation. Is water siphoning out of the drain hose? Drain hose must not be more than 4.5” (114 mm) into the drain pipe. Make sure drain hose is not sealed into drain pipe, and that there is an air gap for ventilation. Ensure that drain height is between 39” (991 mm) and 8’ (2.4 m) above the floor. May signify problem with water inlet valves. Pressure transducer fault on main control. May signify problem with lid lock. See TEST #2: Valves, page 6-7, TEST #6: Water Level, page 6-13, or TEST #8: Lid Lock, page 6-15.
“drn” or “dr” F9E1‡ or F9E2	Drain Pump System Problem - Long Drain	<p>Fault is displayed when the water level does not change after the drain pump is on.</p> <ul style="list-style-type: none"> Is the drain hose or the drain pump clogged? Is the drain hose height greater than 8’ (2.4 m)? Is the pressure hose connection from the tub to the main control pinched, kinked, plugged, or leaking air? Too much detergent. Is the pump running? If not, see TEST #7: Drain Pump, page 6-14.

‡This fault will stop the washer during Service Diagnostics.

For Service Technician Use Only

Troubleshooting Guide: Safety Warnings

⚠ DANGER



Electrical Shock Hazard

Only authorized technicians should perform diagnostic voltage measurements.

After performing voltage measurements, disconnect power before servicing.

Failure to follow these instructions can result in death or electrical shock.

⚠ WARNING



Electrical Shock Hazard

Disconnect power before servicing.

Replace all parts and panels before operating.

Failure to do so can result in death or electrical shock.

Voltage Measurement Safety Information

When performing live voltage measurements, you must do the following:

- Verify the controls are in the off position so that the appliance does not start when energized.
- Allow enough space to perform the voltage measurements without obstructions.
- Keep other people a safe distance away from the appliance to prevent potential injury.
- Always use the proper testing equipment.
- After voltage measurements, always disconnect power before servicing.

IMPORTANT: Electrostatic Discharge (ESD) Sensitive Electronics

ESD problems are present everywhere. Most people begin to feel an ESD discharge at approximately 3000V. It takes as little as 10V to destroy, damage, or weaken the main control assembly. The new main control assembly may appear to work well after repair is finished, but a malfunction may occur at a later date due to ESD stress.

- Use an anti-static wrist strap. Connect wrist strap to green ground connection point or unpainted metal in the appliance

-OR-

- Touch your finger repeatedly to a green ground connection point or unpainted metal in the appliance.
- Before removing the part from its package, touch the anti-static bag to a green ground connection point or unpainted metal in the appliance.
- Avoid touching electronic parts or terminal contacts; handle electronic control assembly by edges only.
- When repackaging main control assembly in anti-static bag, observe above instructions.

IMPORTANT SAFETY NOTICE — “For Technicians only”

This service data sheet is intended for use by persons having electrical, electronic, and mechanical experience and knowledge at a level generally considered acceptable in the appliance repair trade. Any attempt to repair a major appliance may result in personal injury and property damage. The manufacturer or seller cannot be responsible, nor assume any liability for injury or damage of any kind arising from the use of this data sheet.

For Service Technician Use Only

Troubleshooting Guide

NOTE: Always check for error codes first (pages 5-9 to 5-11)

Some tests will require accessing components. See page 6-3, for component locations. For detailed troubleshooting procedures, refer to Section 6, "Testing" beginning on page 6-1.

Problem	Possible Cause	Checks & Tests
Won't Power Up <ul style="list-style-type: none"> • No operation • No keypad response • No LEDs or display 	No power to washer.	Check power at outlet, check circuit breakers, fuses, or junction box connections.
	Connection problem between AC plug and main control.	Check the AC power cord for continuity.
	Connections between main control and UI.	Check connections and continuity between main control and UI.
	User Interface problem.	See TEST #4: Keys and Encoders, page 6-11.
	Main Control problem.	See Test #1: Main Control, page 6-5.
Won't Start Cycle No response when START is pressed	Lid lock mechanism not functioning.	1. Lid not closed due to interference. 2. Lock not closed due to interference. 3. See TEST #8: Lid Lock, page 6-15.
	Connections between main control and UI.	Check connections and continuity between main control and UI.
	User Interface problem.	See TEST #4: Keys and Encoders, page 6-11.
	Main Control problem.	See Test #1: Main Control, page 6-5.
UI Won't Accept Selections	Connections between main control and UI.	Check connections and continuity between main control and UI.
	User Interface problem.	See TEST #4: Keys and Encoders, page 6-11.
	Main Control problem.	See Test #1: Main Control, page 6-5.
Won't Fill	No water supplied to washer.	1. Check water connections to washer. 2. Verify that hot and cold waster supply is on.
	Plugged filter/screen.	Check for plugged filter or screen in the water valve or hoses.
	Drain hose installation.	Check for proper drain hose installation.
	Valve problem.	See TEST #2: Valves, page 6-7.
	Main Control problem.	See Test #1: Main Control, page 6-5.
Overfills	Pressure hose.	See TEST #6: Water Level, page 6-13.
	Valve problem.	See TEST #2: Valves, page 6-7.
	Washer requires calibration.	Perform Service Calibration, page 5-6.
	Pressure transducer on main control	See Test #1: Main Control, page 6-5.
Won't Dispense Fabric Softener or Oxi (Oxi not on all models)	No water supplied to washer	1. Check water connections to washer. 2. Verify that hot and cold waster supply is on.
	Obstruction in dispenser.	Clean obstruction from dispenser.
	Valve problem.	See TEST #2: Valves, page 6-7.
	Main Control problem.	See Test #1: Main Control, page 6-5.

For Service Technician Use Only

Troubleshooting Guide (continued)

Problem	Possible Cause	Checks & Tests
Incorrect Water Temperature	Water hose installation.	Make sure inlet hoses are connected properly.
	Temperature thermistor.	See TEST #5: Temperature Thermistor, page 6-12.
	Valve problem.	See TEST #2: Valves, page 6-7.
	Main Control problem.	See Test #1: Main Control, page 6-5.
Won't Agitate	Water covering the impeller?	See TEST #6: Water Level, page 6-13.
	Is lid lock showing open during the cycle?	See TEST #8: Lid Lock, page 6-15
	Harness connections.	Check harness connections between main control and drive system.
	Shifter problem.	See TEST #3a: Drive System - Shifter, page 6-8.
	Motor problem.	See TEST #3b: Drive System - Motor, page 6-10.
	Main Control problem.	See Test #1: Main Control, page 6-5.
Won't Spin	Is lid lock showing open during the cycle?	See TEST #8: Lid Lock, page 6-15.
	Harness connections.	Check harness connections between main control and drive system.
	Shifter problem.	See TEST #3a: Drive System - Shifter, page 6-8.
	Motor problem.	See TEST #3b: Drive System - Motor, page 6-10.
	Main Control problem.	See Test #1: Main Control, page 6-5.
Won't Drain	Drain hose installation.	Check for proper drain hose installation. Make sure it is not inserted more than 4.5" (114 mm). Make sure drain hose is not sealed into drain pipe, and that there is an air gap for ventilation.
	Standpipe position.	Ensure drain height is between 39" (991 mm) and 8' (2.4 m) above the floor.
	Plugged drain hose.	Check drain hose for obstructions.
	Obstructions to drain pump.	Check tub sump under impeller plate & basket for obstructions.
	Harness connections.	Check harness connections between main control and drain pump.
	Drain pump.	See TEST #7: Drain Pump, page 6-14.
	Main Control problem.	See TEST #1: Main Control, page 6-5.
Cycle Time Longer Than Expected	Oversuds.	1. Verify use of HE detergent. 2. Excessive detergent usage.
	Off balance.	1. Load is off balance. 2. Balance ring water leak.
	Drain hose installation.	Check for proper drain hose installation. Make sure it is not inserted more than 4.5" (114 mm). Make sure drain hose is not sealed into drain pipe, and that there is an air gap for ventilation.
	Standpipe position.	Ensure drain height is between 39" (991 mm) and 8' (2.4 m) above the floor.
	Draining slowly.	Check for pump or drain hose obstructions.
	Water pressure drop.	Results in longer fill time.
	Friction or drag on drive.	Check motor and bearings; check for items between tub and basket.
	Weak suspension.	Basket should not bounce up and down more than once when pushed.

For Service Technician Use Only

Troubleshooting Guide (continued)

Problem	Possible Cause	Checks & Tests
Poor Wash Performance Please reference Use & Care Guide	Oversuds.	1. Verify use of HE detergent. 2. Excessive detergent usage.
	Load is tangling.	1. Washer not loaded properly. 2. Perform Service Calibration, page 5-5.
	Incorrect water level.	1. Perform Service Calibration, page 5-5. 2. See TEST #2: Valves, page 6-7. 3. See TEST #6: Water Level, page 6-13.
	Clothes wet after cycle is complete (not water saturated, but very damp)	1. Overloaded washer. 2. Oversuds (see above). 3. Items caught in tub sump. 4. Weak suspension. 5. Shifter not moving into position. 6. Cold/Rinse water > 105°F (40°C). 7. See TEST #7: Drain Pump, page 6-14. 8. See TEST #3b: Drive System - Motor, page 6-10.
	Load not rinsed.	1. Check proper water supply. 2. Not using HE detergent. 3. Washer not loaded properly. 4. Shifter not moving into spin position. 5. See TEST #2: Valves, page 6-7. 6. See TEST #3b: Drive System - Motor, page 6-10.
	Not cleaning clothes	1. Washer not loaded properly. 2. Not using HE detergent. 3. Not using correct cycle. 4. Shifter not moving into position. 5. See TEST #3b: Drive System - Motor, page 6-10.
	Fabric damage.	1. Washer overloaded. 2. Bleach added incorrectly. 3. Sharp items in tub.
	Wrong option or cycle selection.	Refer customer to "Use & Care Guide".

Notes

Section 6: Testing

This section provides a wiring diagram, control board specifications, testing procedures and strip circuits for the “Whirlpool 2014 CABRIO® Top Load Direct Drive Washer.”

- Testing: Safety Information
- Component Locations
- Wiring Diagram
- Component Testing
- TEST #1: Main Control
- TEST #2: Valves
- TEST #3a: Drive System - Shifter
- TEST #3b: Drive System - Motor
- TEST #4: Keys and Encoders
- TEST #5: Temperature Thermistor
- TEST #6: Water Level
- TEST #7: Drain & Recirculation Pump
- TEST #8: Lid Lock
- TEST #9: Heater Element
- Notes

For Service Technician Use Only

⚠ DANGER

<p style="text-align: center;">Electrical Shock Hazard</p> <p>Only authorized technicians should perform diagnostic voltage measurements.</p> <p>After performing voltage measurements, disconnect power before servicing.</p> <p>Failure to follow these instructions can result in death or electrical shock.</p>

⚠ WARNING

<p style="text-align: center;">Electrical Shock Hazard</p> <p>Disconnect power before servicing.</p> <p>Replace all parts and panels before operating.</p> <p>Failure to do so can result in death or electrical shock.</p>

<h3 style="margin: 0;">Voltage Measurement Safety Information</h3> <p>When performing live voltage measurements, you must do the following:</p> <ul style="list-style-type: none"> ■ Verify the controls are in the off position so that the appliance does not start when energized. ■ Allow enough space to perform the voltage measurements without obstructions. ■ Keep other people a safe distance away from the appliance to prevent potential injury. ■ Always use the proper testing equipment. ■ After voltage measurements, always disconnect power before servicing.
--

<p>IMPORTANT: Electrostatic Discharge (ESD) Sensitive Electronics ESD problems are present everywhere. Most people begin to feel an ESD discharge at approximately 3000V. It takes as little as 10V to destroy, damage, or weaken the main control assembly. The new main control assembly may appear to work well after repair is finished, but a malfunction may occur at a later date due to ESD stress.</p> <ul style="list-style-type: none"> ■ Use an anti-static wrist strap. Connect wrist strap to green ground connection point or unpainted metal in the appliance <p style="text-align: center;">-OR-</p> <ul style="list-style-type: none"> ■ Touch your finger repeatedly to a green ground connection point or unpainted metal in the appliance. ■ Before removing the part from its package, touch the anti-static bag to a green ground connection point or unpainted metal in the appliance. ■ Avoid touching electronic parts or terminal contacts; handle electronic control assembly by edges only. ■ When repackaging main control assembly in anti-static bag, observe above instructions.
--

<p style="text-align: center;">IMPORTANT SAFETY NOTICE — “For Technicians only”</p> <p>This service data sheet is intended for use by persons having electrical, electronic, and mechanical experience and knowledge at a level generally considered acceptable in the appliance repair trade. Any attempt to repair a major appliance may result in personal injury and property damage. The manufacturer or seller cannot be responsible, nor assume any liability for injury or damage of any kind arising from the use of this data sheet.</p>

For Service Technician Use Only

COMPONENT LOCATIONS — CONSOLE ELECTRONICS & VALVES

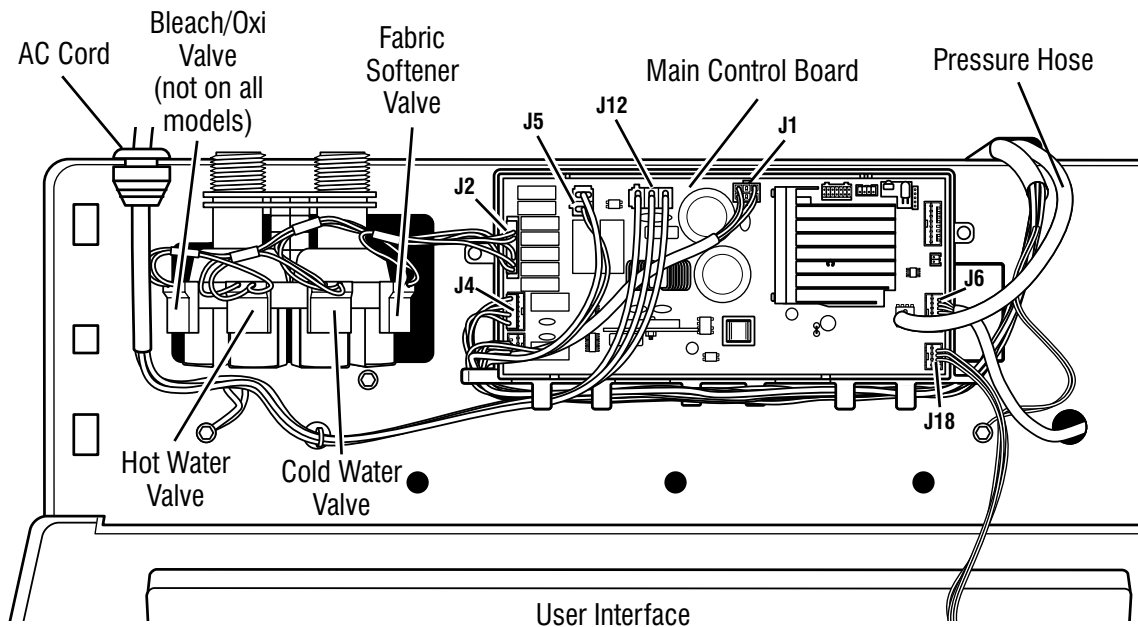

COMPONENTS LOCATIONS, BOTTOM VIEW — DRIVE SYSTEM & PUMPS*

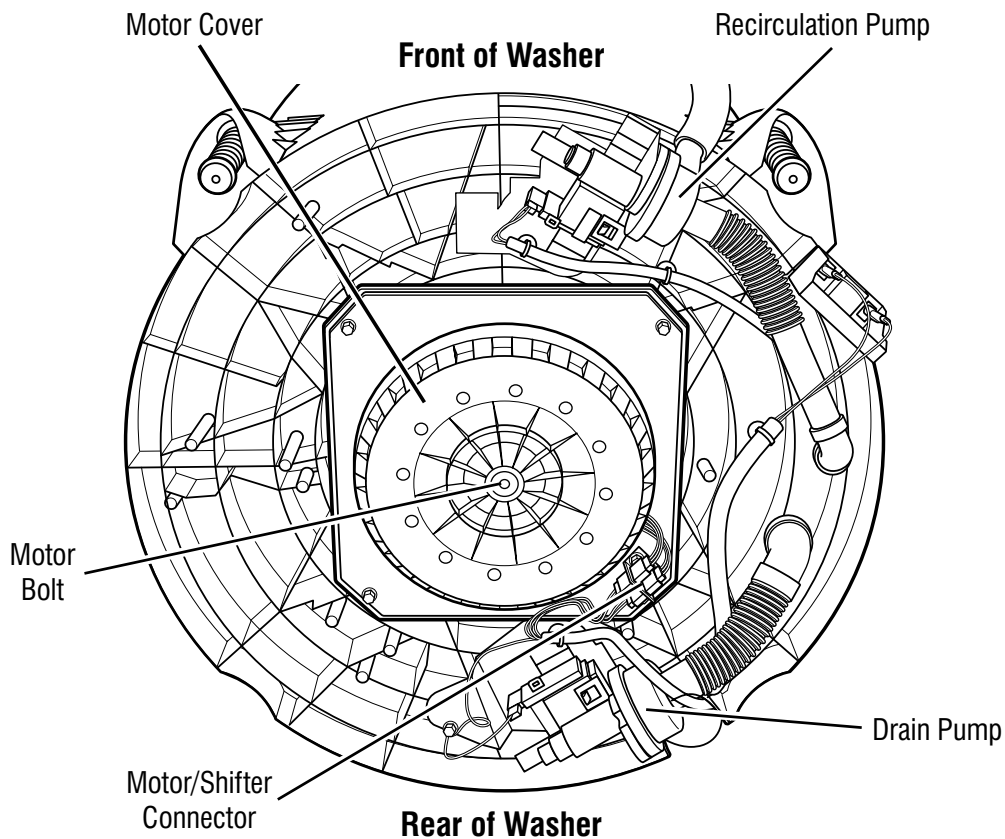

For Service Technician Use Only

WIRING DIAGRAM

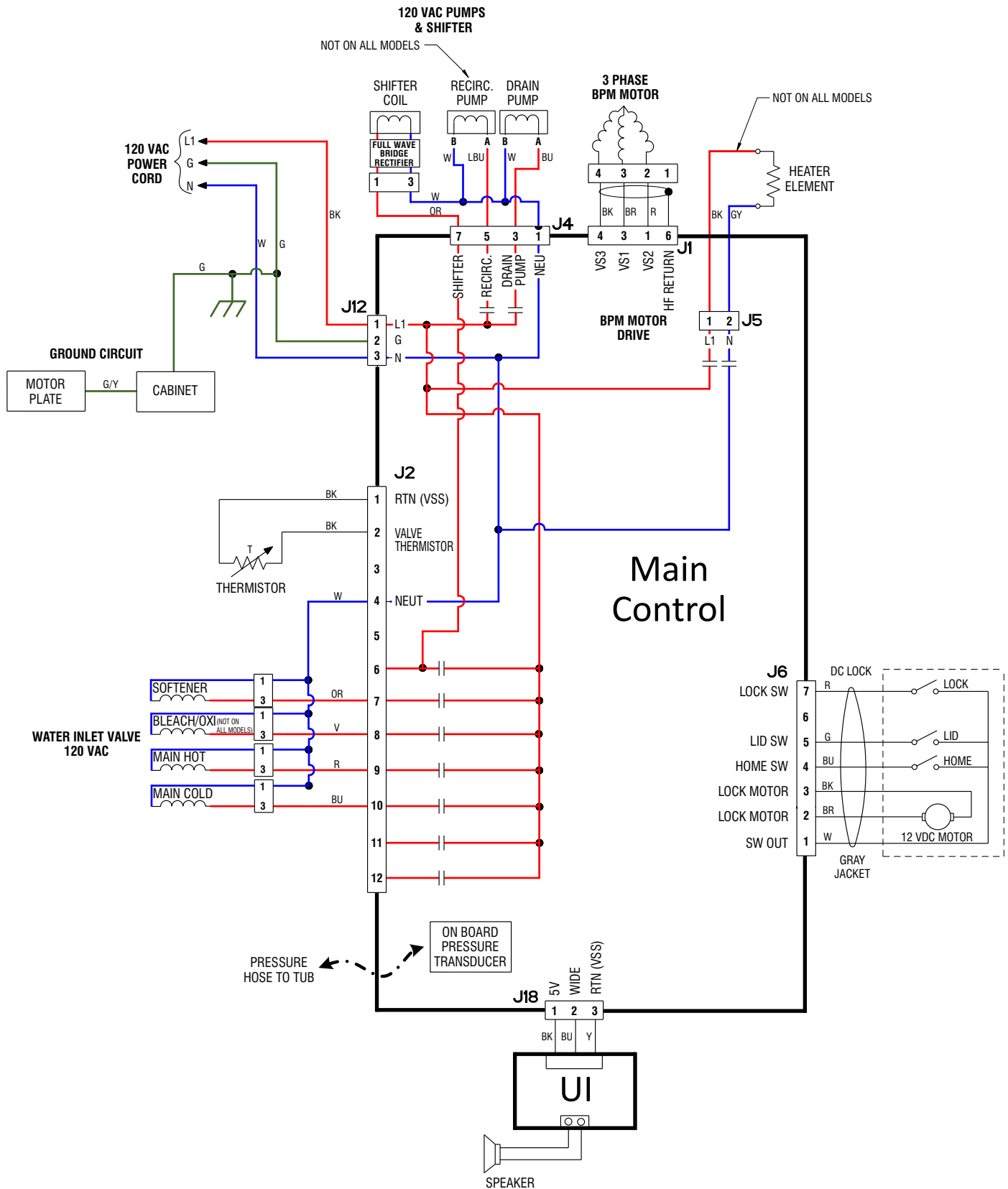

For Service Technician Use Only

⚠ DANGER



Electrical Shock Hazard

Only authorized technicians should perform diagnostic voltage measurements.

After performing voltage measurements, disconnect power before servicing.

Failure to follow these instructions can result in death or electrical shock.

Component Testing

TESTING WASHER COMPONENTS FROM THE CONTROL

Before testing any of the components, perform the following checks:

- The most common cause for mis-diagnosed control failure is poor connections. Therefore, disconnecting, inspecting and reconnecting wires will be necessary throughout test procedures.
- All tests/checks should be made with a VOM or DVM having a sensitivity of 20,000 ohms-per-volt DC, or greater.
- Check all connections before replacing components, looking for broken or loose wires, failed terminals, or wires not pressed into connectors far enough.
- Voltage checks must be made with all connectors attached to the boards.
- Resistance checks must be made with power cord unplugged or power disconnected, and with wiring harness or connectors disconnected from the control.

The testing procedures in this section may require the use of needle probes to measure voltage. Failure to use needle probes will damage the connectors.

TEST #1: Main Control

This test checks for incoming and outgoing power to and from main control. This test assumes that proper voltage is present at the outlet.

1. Unplug washer or disconnect power.
2. Remove console to access main control.
3. Verify that ALL connectors are inserted all the way into the main control.
4. With a voltmeter set to AC, connect black probe to J12-3 (Neutral) and red probe to J12-1 (L1). Plug in washer or reconnect power.
 - If 120VAC is present, go to step 6.
 - If 120VAC is not present, check the AC power cord for continuity (Wiring Diagram, page 6-4.)
5. Is the "Diagnostic LED" flashing or continuously 'ON' or 'OFF'? (See Figure 1 on page 6-6 for LED location.)
 - Flashing: (+5VDC present and micro operating) proceed to Key Activation & Encoder Test, page 5-4.
 - ON: (+5VDC present but micro failure) continue to step 9.
 - OFF: (+5VDC missing or micro failure) proceed to step 7.
6. Check if console UI is affecting the main control DC supply.
 - a. Unplug washer or disconnect power.
 - b. Remove connector J18 from main control.
 - c. Plug in washer or reconnect power.
 - d. Recheck the Diagnostic LED per step 6.
 - If the diagnostic LED is now flashing, go to Test #4: Keys and Encoders, "None of the indicators light up", step 4, page 6-11. If diagnostic LED is not flashing, continue to step 8.
7. Perform voltage checks inside header J18 on the board – do not short pins together. Unplug washer or disconnect power.
 - a. With a voltmeter set to DC, connect black probe to J18-3 (Circuit Gnd) and red probe to J18-1 (+5VDC). Plug in washer or reconnect power.
 - If DC voltage is not present, go to step 9.
 - If the DC voltage is present, but the diagnostic LED is not flashing, continue to step 9.
8. Main Control has malfunctioned.
 - a. Unplug washer or disconnect power.
 - b. Replace the main control.
 - c. Reassemble all parts and panels.
 - d. Plug in washer or reconnect power. Perform Service Diagnostics to verify repair.

Continue to next page for Main Control Board diagram and Main Control Board connectors & pinouts

For Service Technician Use Only

MAIN CONTROL BOARD (FIGURE 1)

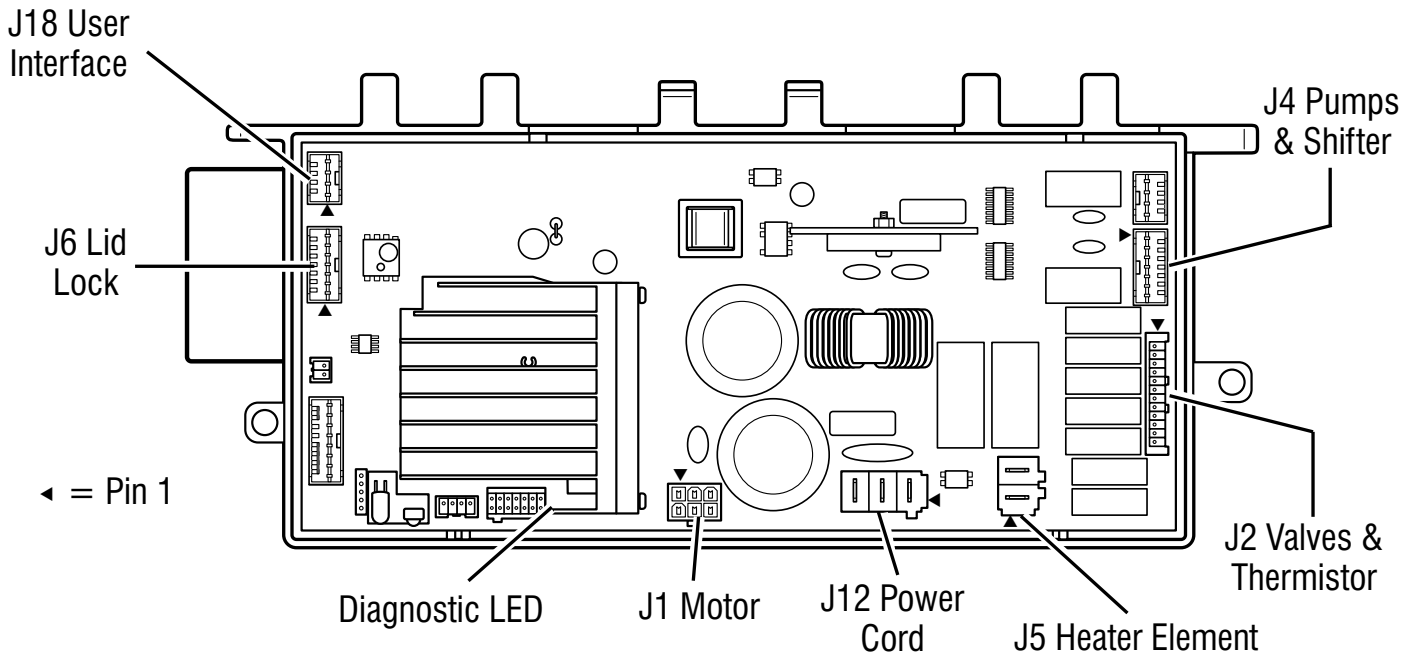

MAIN CONTROL BOARD CONNECTORS AND PINOUTS (FIGURE 2)

MOTOR		J1 Motor	J1-6 HF Return	J1-5 Open	J1-4 Blk VS3	J1-3 Brn VS1	J1-2 Open	J1-1 Red VS2									
		VALVES & THERMISTOR		J2 Valves & Thermistor	J2-12 Open	J2-11 Open	J2-10 Blu Cold Valve	J2-9 Red Hot Valve	J2-8 Vlt Oxi Valve (not on all models)	J2-7 Orn Softener Valve	J2-6 Open	J2-5 Open	J2-4 Wht Neutral	J2-3 Open	J2-2 Blk Valve Thermistor	J2-1 Blk Rtn (VSS)	
				PUMPS & SHIFTER		J4 Pumps & Shifter	J4-7 Orn Shifter	J4-5 Lt Blu Recirc. Pump (not on all models)	J4-3 Blu Drain Pump	J4-1 Wht Neutral							
						HEATER ELEMENT		J5 Heater Element	J5-2 Gry Neutral	J5-1 Blk L1							
								LID LOCK		J6 Lid Lock	J6-7 Red Lock Sw	J6-6 Open	J6-5 Grn Lid Sw	J6-4 Blu Home Sw	J6-3 Blk Lock Motor	J6-2 Brn Lock Motor	J6-1 Wht Sw Out
										UI		J18 UI	J18-3 Blk Rtn (VSS)	J18-2 Blu Wide	J18-1 Yel +5VDC		
POWER CORD						J12 Power Cord	J12-3 Wht Neutral					J12-2 Grn Ground	J12-1 Blk L1				

For Service Technician Use Only

⚠ WARNING



Electrical Shock Hazard

Disconnect power before servicing.

Replace all parts and panels before operating.

Failure to do so can result in death or electrical shock.

3. Check resistance of the valve coils across the following J2 connector pinouts:

Valve	Pinout
Fabric Softener	J2, 4 & 7
OXI (not on all models)	J2, 4 & 8
Hot	J2, 4 & 9
Cold	J2, 4 & 10

Resistance should be 790–840 Ω.

- If resistance readings are tens of ohms outside of range, replace the valve assembly.
- If resistance readings are within range, replace main control and perform Service Diagnostics to verify repair.

TEST #2 Valves

This test checks the electrical connections to the valves, and the valves themselves.

1. Check the relays and electrical connections to the valves by performing the Cold, Hot, Oxi (not on all models), and Fabric Softener Service Test Load Control on page 5-5. Each test activates and deactivates the selected valve. The following steps assume one (or more) valve(s) did not turn on.
2. For the valve(s) in question check the individual solenoid valves:
 - a. Unplug washer or disconnect power.
 - b. Remove console to access main control.
 - c. Remove connector J2 from main control. Refer to main control diagram on page 6-6.
 - d. Check harness connection to solenoid valves.

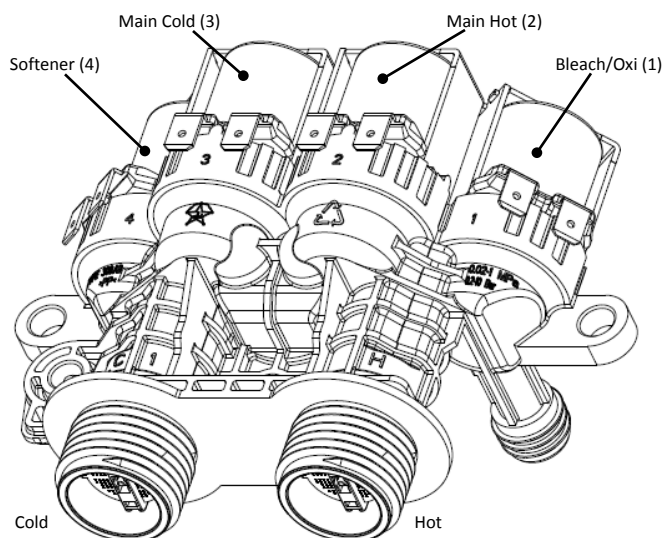

Figure 1

VALVES

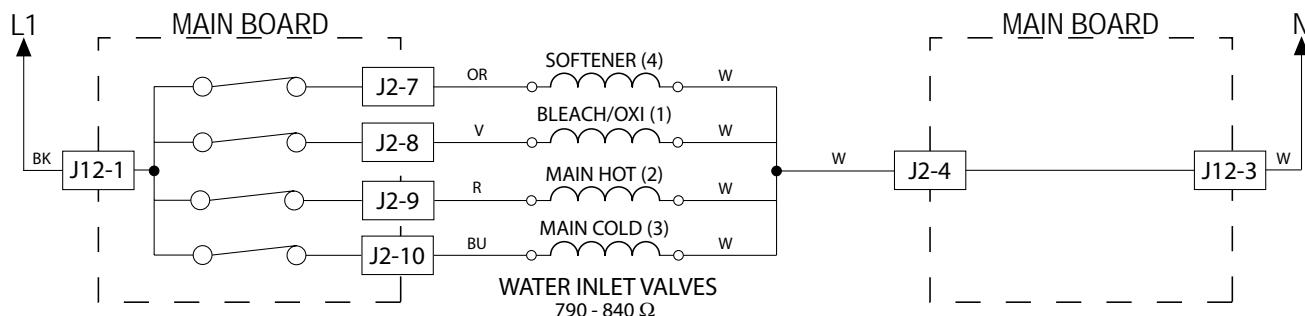



Figure 2

For Service Technician Use Only

⚠ DANGER



Electrical Shock Hazard

Only authorized technicians should perform diagnostic voltage measurements.

After performing voltage measurements, disconnect power before servicing.

Failure to follow these instructions can result in death or electrical shock.

4. Remove console to access main control.
5. Visually check that the J4 connector is inserted all the way into the main control.
 - If visual checks pass, go to step 6.
 - If connector is not inserted properly, reconnect J4 and repeat step 1.
6. With a voltmeter set to AC, connect the black probe to J4-1 (N) and red probe to J4-7 (L1). Plug in washer or reconnect power.
7. Activate shifter motor by switching the shifter output ON and OFF. Energize outputs using Service Load Control Mode on page 5-5.

NOTE: Motor must be stopped to toggle the shifter. Alternately, Spin and Agitate can be commanded to switch shifter in Service Load Control Mode.

IMPORTANT: Lid must be closed with Lid Lock enabled to run the Spin and Agitate tests.

 - If 120VAC is present, go to step 8.
 - If 120VAC is not present, go to step 12.
8. Unplug washer or disconnect power.
9. Tilt washer back and remove sound pad (if equipped) to access the drive system (see Figure 1).

TEST #3 Drive System

Pre-Test Procedure

1. Activate Service Diagnostic Test Mode, retrieve any fault/error codes, and clear them. If the displayed error codes are F7E3, F7E4, F7E5, F7E6, F7E7, there is likely a motor or shifter related issue.
2. Once the error codes are cleared, enter Service Load Control Mode and run the Heavy Agitation test; if the motor runs after 15–20 seconds, there is not a problem with the motor, control, or motor wiring harness connections.
3. While in Service Load Control Mode, try to get the washer to spin; if the motor hums briefly and then shuts down, go to Fault Code Display Mode and check for fault codes.

TEST #3a: Drive System – Shifter

This test checks connections, shifter coil, and harness.

NOTE: Lid must be closed and locked for the motor to agitate or spin.

IMPORTANT: Drain water from tub before accessing bottom of washer.

Functional Check:

1. Check the shifter and electrical connections by performing both the Spin and Agitate tests under Service Load Control Mode on page 5-5. The following steps assume that this step was unsuccessful.
2. Unplug washer or disconnect power.
3. The motor and shifter should be able to be turned independently of each other. If they are locked together, there is a shifter slider issue. Proceed to step 12.

NOTE: Rotating the impeller quickly can cause the UI to attempt to power up, and may cause audible feedback and the main control to power up and apply braking torque to the impeller.

 - If basket and impeller turn freely, go to step 4.
 - If basket and/or impeller do not turn freely, determine what is causing the mechanical friction or lockup.

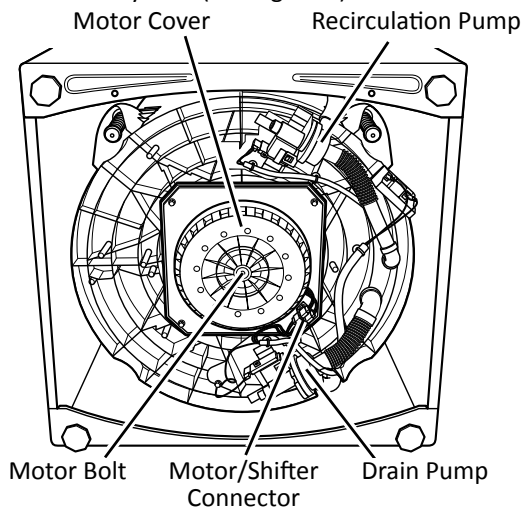

Figure 1 - Drive Area, Viewed From Bottom, Sound Pad (if equipped) Removed

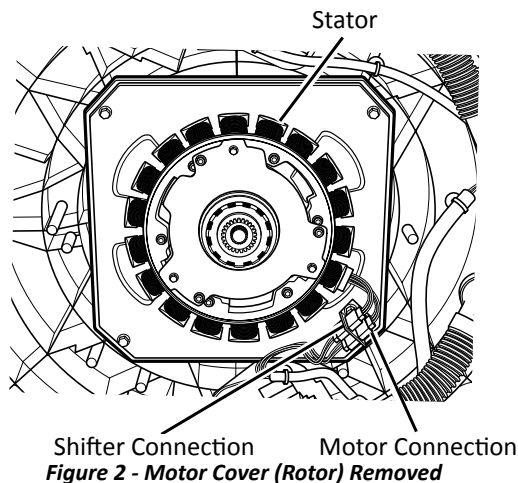

Figure 2 - Motor Cover (Rotor) Removed

For Service Technician Use Only

10. Visually check the electrical connections to the shifter.
 - If visual check passes, go to step 11.
 - If connections are loose, reconnect the electrical connections and repeat step 1.
11. With an ohmmeter, check the harness for continuity between the shifter and main control using the following pinouts. See chart below.

Shifter and Pump Connector Harness	
J4-1 (White wire)	To shifter connector Pin 3 (White wire)
J4-7 (Orange wire)	To shifter connector Pin (Orange wire)

- If there is continuity, go to step 12.
 - If there is no continuity, replace the lower washer harness and repeat step 1.
12. Remove the motor bolt, then the motor cover (see Figure 2). Remove the motor stator and the shifter coil and confirm that the slider on the motor shaft moves freely (see Figure 3).
 - If slider moves freely, and there are no indications of rubbing on the inside diameter of the shifter coil and outside diameter of the slider, go to step 13.
 - If slider binds or does not move freely, or there are indications of rubbing on the inside diameter of the shifter coil or outside diameter of the slider, replace the drive.

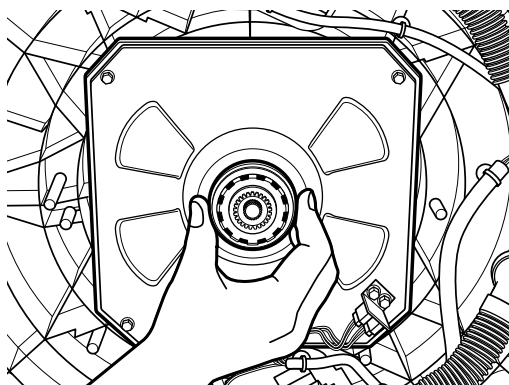

Figure 3 - Checking Slider Movement/Appearance

- a. Unplug washer or disconnect power.
 - b. Replace the drive.
 - c. Reassemble all parts and panels.
 - d. Plug in washer or reconnect power. Perform Service Diagnostics to verify repair.
13. If the preceding steps did not correct the problem, replace the main control.
 - a. Unplug washer or disconnect power.
 - b. Replace the main control.
 - c. Reassemble all parts and panels.
 - d. Plug in washer or reconnect power. Perform Service Diagnostics to verify repair.

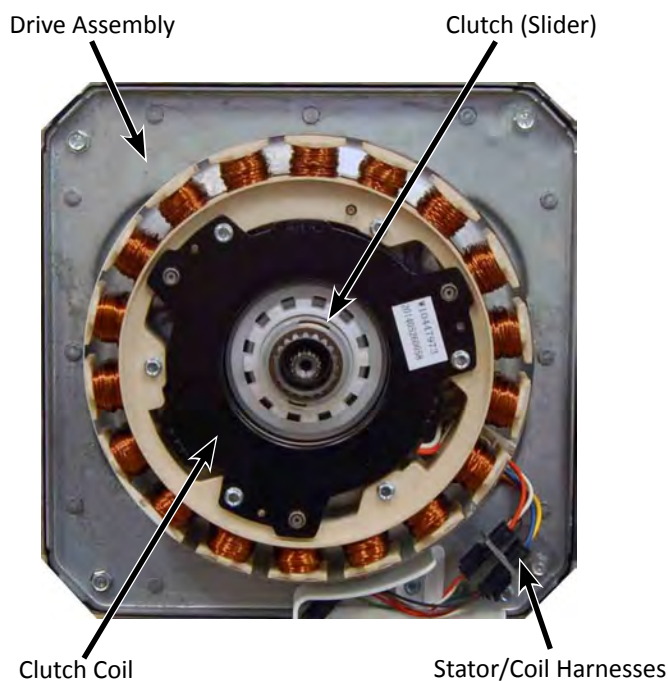

Figure 4 - Drive Assembly, Clutch Coil, and Clutch (Slider)

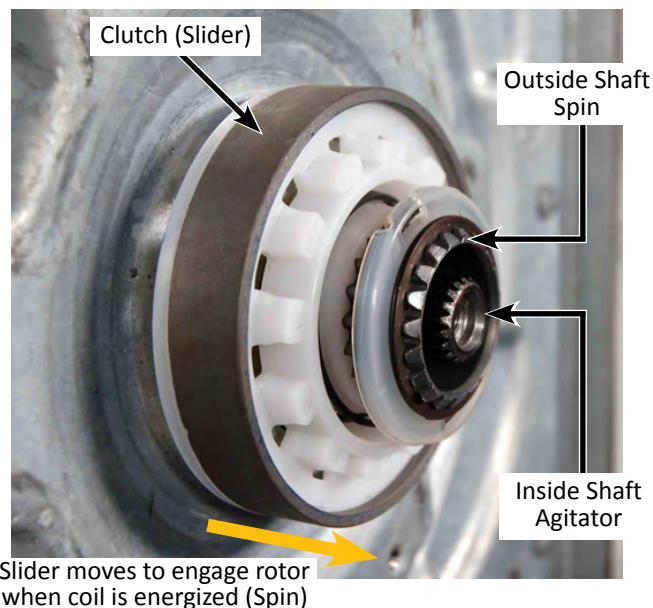



Figure 5 - Clutch (Slider) shown with Clutch Coil removed

Continue to next page for TEST #3b: Drive System - Motor

For Service Technician Use Only

⚠ **WARNING**



Electrical Shock Hazard
Disconnect power before servicing.
Replace all parts and panels before operating.
Failure to do so can result in death or electrical shock.

TEST #3b: Drive System - Motor

This test checks the wiring to the motor and the motor itself.

NOTE: Drain water from tub and remove any wash load items present in the basket.

1. See Activating Service Diagnostic Mode, page 5-3, and check the motor and electrical connections by performing the Low, Mid, and High Speed Spin Test under Service Load Control Mode, page 5-5. The following steps assume that this step failed.
2. Unplug washer or disconnect power.
3. Check to see if impeller will turn freely and is not connected to the basket.

NOTE: Rotating the impeller quickly can cause the UI to attempt to power up, and may cause audible feedback and the main control to power up and apply braking torque to the impeller.

- If impeller turns freely, go to step 4.
 - If impeller does not turn freely, determine what is causing the mechanical friction or lockup.
4. Remove console to access main control.
 5. Visually check that the J1 connector is inserted all the way into the main control.
 - If visual checks pass, go to step 6.
 - If visual checks fail, reconnect J1 and repeat step 1.
 6. With an ohmmeter, verify resistance values as shown below:

Check between connector pins	Resistance value should be:	Go to Step 7 if values are:	Go to Step 10 if values are:	Go to Step 10 if:
J1 1-3	8-10 ohms	Much higher than 10 ohms	Much less than 8 ohms	Resistances are all correct
3-4	8-10 ohms			

7. Tilt washer back to access the bottom of the washer and the drive motor area (see Figure 1, page 6-8).
8. Visually check that the motor connection on the drive is fully inserted into its mating connector.

- If visual checks pass, go to step 9.
 - If visual checks fail, reconnect motor connector on drive plate and repeat step 1.
9. With an ohmmeter, check for continuity on the motor harness between all pins on the J1 machine/motor control connector and the drive motor connector.
 - If there is continuity, go to step 10.
 - If there is no continuity, replace the lower washer harness and run Service Diagnostics to verify repair.
 10. Tilt washer back (if it is not already) to disconnect the motor connector and use an ohmmeter to verify the motor resistance values at the drive motor connector (see Figure 2, page 6-8).

Check between drive motor connector	Resistance value should be:	Go to Step 11 if values are:	Go to Step 14 if values are:	Go to Step 15 if:
2-3 (R-BR)	8-10 ohms	Much higher than 10 ohms	Much less than 8 ohms	Resistances are all correct
3-4 (BR-BK)	8-10 ohms			

11. Remove the motor bolt, then the motor cover (see Figure 2, page 6-8).
12. Remove the shifter coil and stator to access the motor connection.
13. Visually check that motor electrical connection cover is fully seated (see Figure 1).
 - If visual check passes, go to step 14.
 - If visual check fails, fully seat the motor connection cover, reassemble stator and motor cover, and repeat step 1.

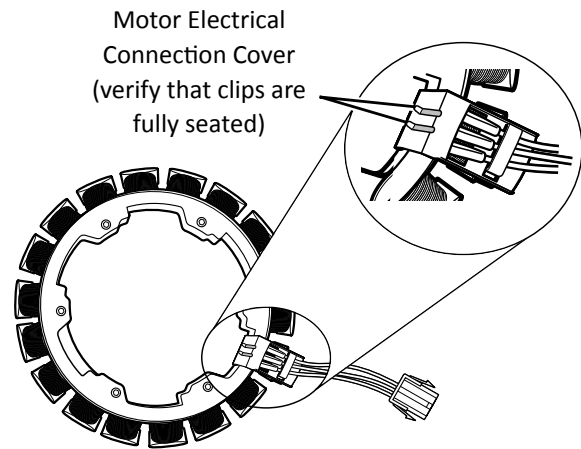



Figure 1 - Removing Shifter Coil and Checking Motor Electrical Connection

14. Replace the drive and perform Service Diagnostics to verify repair.
 - If the motor still fails to operate, go to step 15.
15. If the tests above have failed to fix motor drive issues, the main control has failed:
 - Unplug washer or disconnect power.
 - Replace the main control assembly.
 - Perform Service Diagnostics to verify repair.

For Service Technician Use Only

⚠ WARNING



Electrical Shock Hazard
Disconnect power before servicing.
Replace all parts and panels before operating.
Failure to do so can result in death or electrical shock.

TEST #4: Keys and Encoders

Keys and Encoders Test:

This test is performed when any of the following situations occurs during “Key Activation & Encoder Test” on page 5-4.

- **None of the indicators light up**
- **Some buttons do not light indicators**
- **No audio feedback is heard**

None of the indicators light up:

1. Unplug washer or disconnect power.
2. Access the console’s electronic assemblies and visually check that the J18 connector is inserted all the way into the main control and that the UI harness connector is fully seated on the UI. If the speaker connector is visible, visually verify that the speaker connector is fully seated.
3. If both visual checks pass, follow procedure under TEST #1, “Main Control” on page 6-5 to verify supply voltages.
4. Verify the continuity of the UI harness.

ACU J18 - Pin 1	Black	UI J6 - Pin 3
ACU J18 - Pin 2	Blue	UI J6 - Pin 2
ACU J18 - Pin 3	Yellow	UI J6 - Pin 1

- If continuity fails, replace the UI harness and go to step 5.
 - If continuity passes, replace the user interface and go to step 5.
5. Reassemble all parts and panels.
 6. Plug in washer or reconnect power.
 7. To verify repair, activate the Service Diagnostic Mode, and then perform Key Activation & Encoder Test on page 5-4.

Some buttons do not light indicators:

1. Unplug washer or disconnect power.
2. Replace the UI assembly.
3. Reassemble all parts and panels.
4. Plug in washer or reconnect power.
5. To verify repair, activate the Service Diagnostic Mode, and then perform Key Activation & Encoder Test on page 5-4.

No audio feedback is heard:

1. Enter the Service Diagnostic Mode, and then perform Key Activation & Encoder Test on page 5-4.
 - If audio feedback is heard with each button press while in Key Activation & Encoder Test mode, continue to step 2.
 - If no audio feedback is heard with each button press while in Key Activation & Encoder Test mode, continue to step 4.
2. Exit Key Activation & Encoder Test by pressing POWER.
3. Turn on the washer and enable audio feedback in normal mode:
 - On Whirlpool models, press and hold “End Beep” for 3 seconds to change the button sounds level (Off, Low, Med, High). Each press and hold increments the sound one level.
 - On Maytag models, press “Audio Level” to change the audio level (Off, Low, High).
 - On Kenmore models, press and hold “Cycle Signal” for 3 seconds to change the button sounds level (Off, Low, ...High). Each press and hold increments the sound one level.
4. Unplug washer or disconnect power.
5. Access the console electronics and, if needed, remove the user interface from the console shell and visually check that the speaker connector on the UI is fully seated.
6. If visual check passes, replace the user interface assembly.
7. Reassemble all parts and panels.
8. Plug in washer or reconnect power. Perform Service Diagnostics on page 5-6. To verify repair, activate the Service Diagnostic Mode, and then perform Key Activation & Encoder Test on page 5-4.

For Service Technician Use Only

⚠ WARNING



Electrical Shock Hazard
Disconnect power before servicing.
Replace all parts and panels before operating.
Failure to do so can result in death or electrical shock.

thermistor between pins J2-1 and J2-2. Verify that the approximate resistance, shown in the table below, is within ambient temperature range.

THERMISTOR RESISTANCE		
Approx. Temperature		Approx. Resistance
F°	C°	(KΩ)
32	0	163
41	5	127
50	10	100
59	15	79
68	20	62
77	25	50
86	30	40
95	35	33
104	40	27
113	45	22
122	50	18
131	55	15
140	60	12
149	65	10

TEST #5: Temperature Thermistor

This test checks valves, main control, temperature thermistor, and wiring.

1. Check the cold valve by performing Cold Valve test under Service Load Control Mode in Service Diagnostic Mode on page 5-5.
 - If cold water is being dispensed, proceed to step 2.
 - If hot water is being dispensed, verify proper hose connection.
2. Check the hot valve by performing Hot Valve test under Service Load Control Mode in Service Diagnostic Mode on page 5-5.
 - If hot water is being dispensed, proceed to step 3.
 - If cold water is being dispensed, ensure that household hot water is present.
3. Unplug washer or disconnect power.
4. Remove console to access main control.
5. Remove connector J2 from the main control. With an ohmmeter, measure the resistance of the temperature

- If the resistance is within the range shown in the table, go to step 6.
- If the resistance is infinite or close to zero, replace the valve assembly.

NOTE: Most thermistor errors are a result of the resistance being out of range. If the temperature thermistor malfunctions, the washer will default to pre-programmed wash settings.

6. If the thermistor is good, replace main control and perform Service Diagnostics (see page 5-6) to verify repair.

THERMISTOR

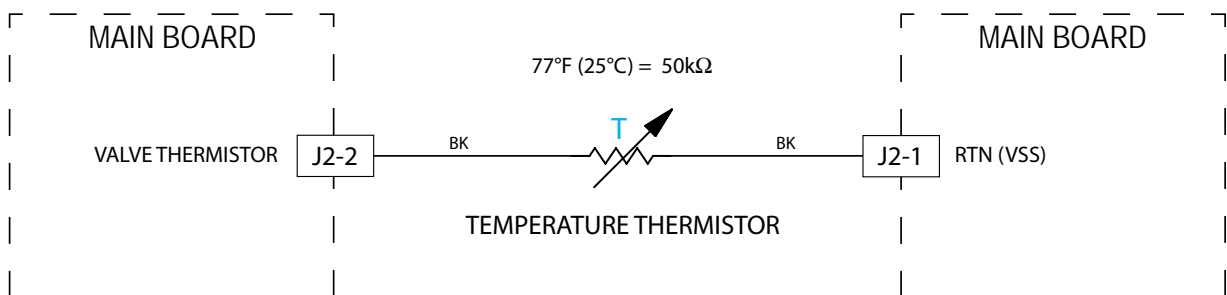

Figure 1

For Service Technician Use Only

⚠ WARNING



Electrical Shock Hazard
Disconnect power before servicing.
Replace all parts and panels before operating.
Failure to do so can result in death or electrical shock.

TEST #6: Water Level

This test checks the water level sensing components.

NOTE: Usually, if the pressure transducer malfunctions, the washer will generate a long fill, or long drain error.

1. Check the functionality of the pressure transducer by running a small load cycle. The valves should turn off automatically after sensing the correct water level in the tub. The following steps assume that this step was unsuccessful.
2. Drain the tub until all water has been removed.
3. Unplug washer or disconnect power.
4. Remove console to access main control.
5. Check hose connection between the pressure transducer on the main control (Figure 1) and the pressure dome attached to the tub (Figure 2).
6. Check to ensure hose is routed correctly in the lower cabinet and not pinched or crimped inside the console or by the back panel.
7. Verify there is no water, suds, or debris in the hose or dome. Disconnect hose from main control and blow into hose to clear water, suds, or debris.
8. Check hose for leaks. Replace if needed.
9. If the preceding steps did not correct the problem, replace main control and perform Service Diagnostics. Run fill cycle to test and verify repair.

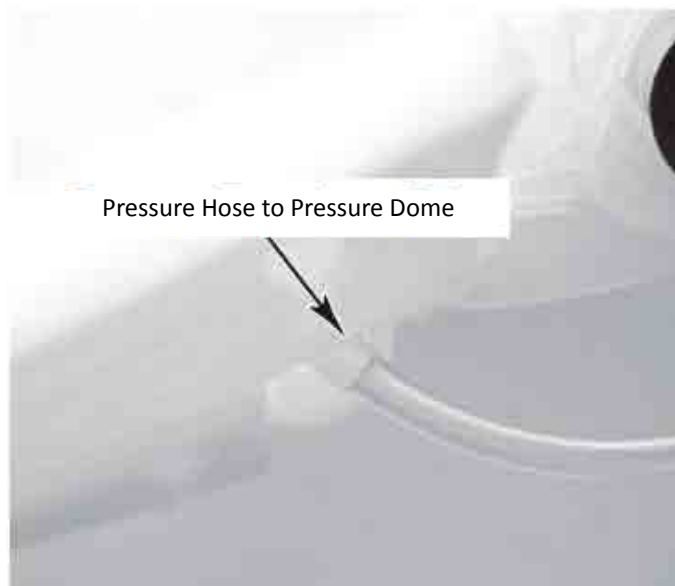

Figure 2

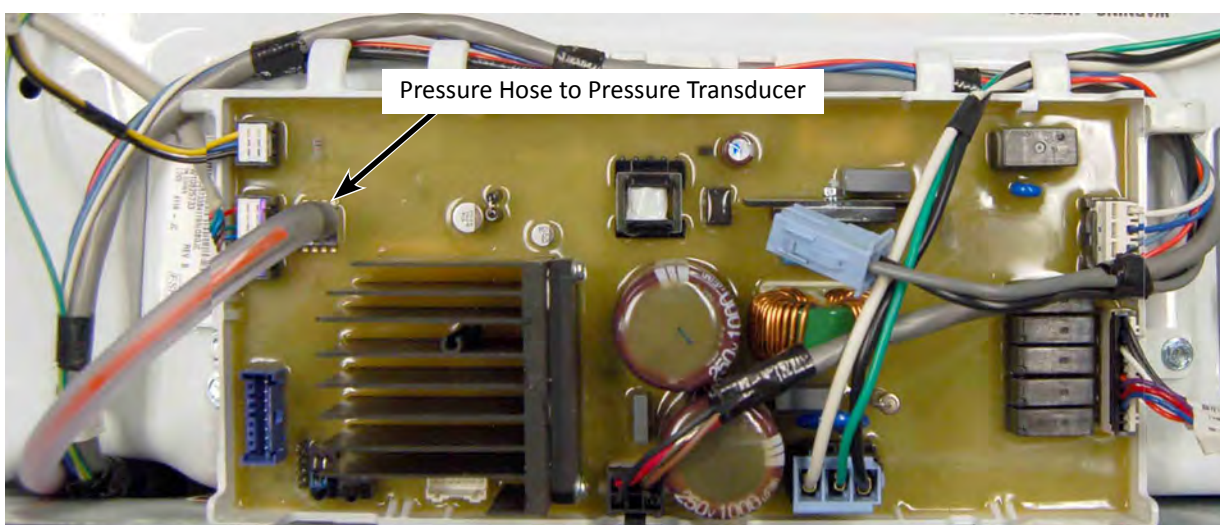



Figure 1

For Service Technician Use Only

⚠ WARNING



Electrical Shock Hazard
Disconnect power before servicing.
Replace all parts and panels before operating.
Failure to do so can result in death or electrical shock.

- If values are open or out of range, go to step 7.
 - If values are correct, go to step 11.
7. Tilt washer back to access drain pump (and recirculation pump, on some models). Verify pump is free from obstructions.
 8. Visually check the electrical connections at the drain pump (and, on some models, the recirculation pump).
 - If visual check passes, go to step 9.
 - If connections are loose, reconnect the electrical connections and repeat step 2.
 9. With an ohmmeter, check harness for continuity between the drain pump (and recirculation pump, on some models) and main control.
See chart below.

TEST #7: Drain & Recirculation Pump

Perform the following checks if washer does not drain.

IMPORTANT: Drain water from tub before accessing bottom of washer.

1. Check for obstructions in the usual areas. Clean and then perform step 2.
2. Check the drain pump (and recirculation pump, on some models) and electrical connections by turning on the drain pump (and recirculation pump, on some models) in Service Load Control Mode on page 5-5. The following steps assume that this step was unsuccessful.
3. Unplug washer or disconnect power.
4. Remove console to access main control.
5. Visually check that the J4 connector is inserted all the way into the main control.
 - If visual check passes, go to step 6.
 - If connector is not inserted properly, reconnect J4 and repeat step 2.
6. Remove connector **J4** from main control. With an ohmmeter, verify resistance values shown below across the following J4 connector pinouts:

Component	J4 Connector Pinout	Correct Resistance
Drain Pump	J4, 1 & 3	12-15 Ω
Recirc. Pump*	J4, 1 & 5	26-32 Ω

*on some models

Main Control to Drain Pump (and Recirculation Pump)
Drain Pump Pin 1 to Main Control J4-1 (White Wire)
Drain Pump Pin 2 to Main Control J4-3 (Blue Wire)
Recirc. Pump* Pin 1 to Main Control J4-1 (White Wire)
Recirc. Pump* Pin 2 to Main Control J4-5 (Lt Blue Wire)

*on some models

- If there is continuity, go to step 10.
 - If there is no continuity, replace the lower washer harness and repeat step 2.
10. With an ohmmeter, measure the resistance across the two pump terminals. Resistance should be as shown in the chart below:

Component	Correct Resistance
Drain Pump	12-15 Ω
Recirculation Pump*	26-32 Ω

*on some models

- If values are open or out of range, replace the pump motor.
 - If the resistance at the pump motor is correct, go to step 11.
11. If the preceding steps did not correct the drain problem, replace the main control.
 - a. Unplug washer or disconnect power.
 - b. Replace the main control.
 - c. Reassemble all parts and panels.
 - d. Plug in washer or reconnect power. Perform Service Diagnostics to verify repair.

DRAIN & RECIRCULATION PUMPS

Figure 1

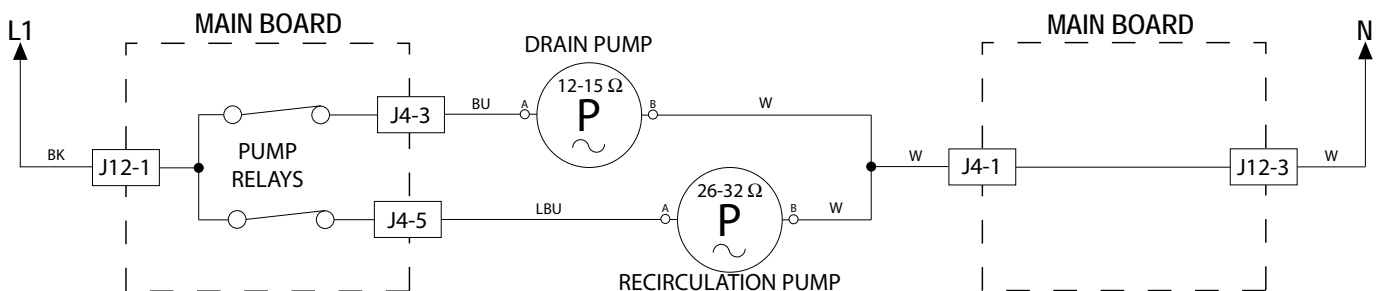

For Service Technician Use Only

⚠ WARNING



Electrical Shock Hazard
Disconnect power before servicing.
Replace all parts and panels before operating.
Failure to do so can result in death or electrical shock.

5. Check the lid lock motor winding and switches by removing J6 from the main control and checking the resistance values shown in the following table:

LID LOCK RESISTANCE			
Component	Resistance Unlocked	Resistance Locked	Contacts
Motor Winding	35 Ω (±5 Ω)	35 Ω (±5 Ω)	J6-2 J6-3
Lock Switch-Home	0 Ω	Open Circuit	J6-1 J6-4
Lock Switch-Lock	Open Circuit	0 Ω	J6-1 J6-7
Lock Switch-Lid	Lid Closed = 0 Ω Lid Open = Open Circuit		J6-1 J6-5

TEST #8: Lid Lock

Perform the following checks if the washer does not lock (or unlock).

1. Check the lid lock by performing Lid Lock test under Service Load Control Mode in Service Diagnostic Mode on page 5-5. The following steps assume that this step was unsuccessful.
2. Unplug washer or disconnect power.
3. Remove console to access main control.
4. Visually check that the J6 connector is inserted all the way into the main control.
 - If visual check passes, go to step 5.
 - If connector is not inserted properly, reconnect J6 and repeat step 1.
5. Check the lid lock motor winding and switches by removing J6 from the main control and checking the resistance values shown in the following table:
 - If resistance values are good, go to step 6.
 - If switch measurements do not match the values shown in the table for unlocked (or locked) condition, a problem exists in the lid lock. Replace the lid lock mechanism.
6. If the preceding steps did not correct the lock problem, replace the main control.
 - a. Unplug washer or disconnect power.
 - b. Replace the main control.
 - c. Reassemble all parts and panels.
 - d. Plug in washer or reconnect power. Perform Service Diagnostics to verify repair.

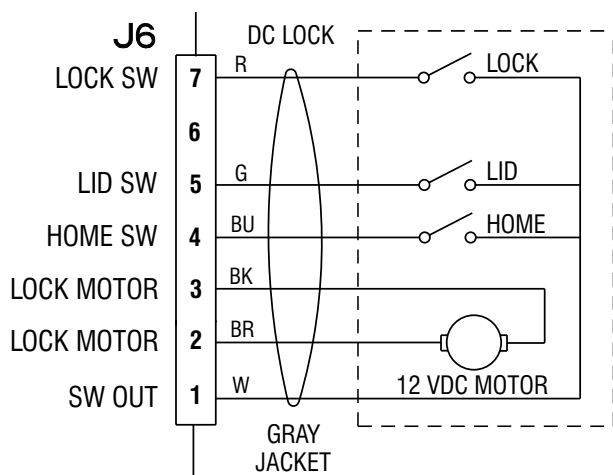



Figure 1 - Lid Lock Schematic



Figure 2 - Lid Lock

For Service Technician Use Only

⚠ WARNING



Electrical Shock Hazard
Disconnect power before servicing.
Replace all parts and panels before operating.
Failure to do so can result in death or electrical shock.

TEST #9: Heater Element (on some models)

Perform the following checks to ensure the heater is functioning properly.

1. Unplug washer or disconnect power.
2. Remove the heater terminal plastic cover.
3. Check the connection to the water heater element.
4. Check the resistance of the heater element. If the heater is open (infinite), replace the heater element and reinstall the heater terminal plastic cover.
5. Visually inspect that the connector on the main control (J5) that plugs into the lower harness is installed correctly (see wiring diagram, page 6-4).
 - If visual check passes, go to step 7.
 - If visual check fails, reconnect cable.
6. If connections are correct, replace the main control.

HEATER ELEMENT

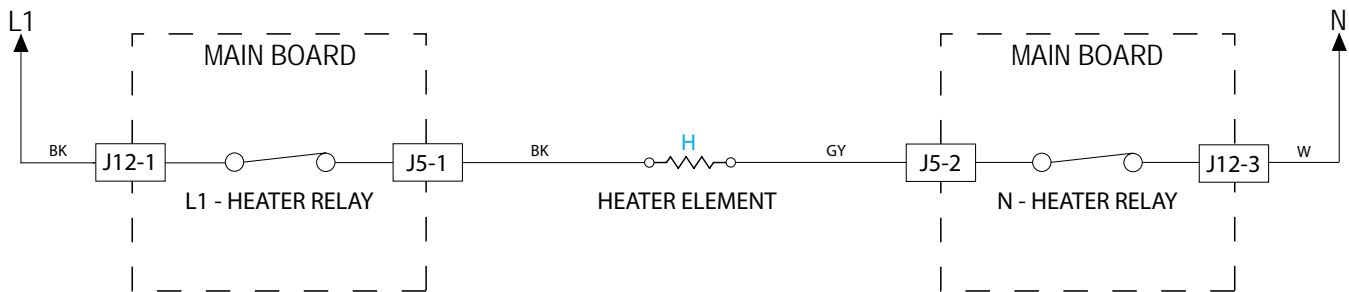

Figure 1

PRODUCT SPECIFICATIONS & WARRANTY INFORMATION SOURCES

IN THE UNITED STATES:

FOR PRODUCT SPECIFICATIONS AND WARRANTY INFORMATION CALL:

FOR WHIRLPOOL PRODUCTS: 1-800-253-1301

FOR TECHNICAL ASSISTANCE WHILE AT THE CUSTOMER'S HOME CALL:

THE TECHNICAL ASSISTANCE LINE: 1-800-832-7174

**HAVE YOUR STORE NUMBER READY TO IDENTIFY YOU AS AN
AUTHORIZED IN-HOME SERVICE PROFESSIONAL**

FOR LITERATURE ORDERS (CUSTOMER EXPERIENCE CENTER):

PHONE: 1-800-851-4605

FOR TECHNICAL INFORMATION AND SERVICE POINTERS:

www.servicematters.com

IN CANADA:

FOR PRODUCT SPECIFICATIONS AND WARRANTY INFORMATION CALL

1-800-461-5681

FOR TECHNICAL ASSISTANCE WHILE AT THE CUSTOMER'S HOME CALL:

THE TECHNICAL ASSISTANCE LINE: 1-800-488-4791

**HAVE YOUR STORE NUMBER READY TO IDENTIFY YOU AS AN
AUTHORIZED IN-HOME SERVICE PROFESSIONAL**

