

TECHNICAL EDUCATION
2013 NEW DESIGN
15" & 18" UNDER COUNTER
ICE MAKERS WITH FILTER



JENN AIR 15" – JIM158XYCX, JIM158XYRS

KITCHENAID 15" – KUIC15NHZS, KUIC15PHZS, KUIC15NPOZP,
KUIC15NNZB, KUIC15NNZW

KITCHENAID 18" – KUIS18NNZB, KUIS18NNZW, KUIS18NNZS,
KUIS18PNZB, KUIS18PNZW, KUIS18PNZS, KUIC18PNZS

KITCHENAID 18" OUTDOOR – KUIO18NNZS

MAYTAG 15" – MIM154ZRS, MIM155ZRS,

WHIRLPOOL 15" – GI15NDXZS, GI15NDXZB, GI15NDXZQ

*All Colors, Introductory Models

FORWARD

This Job Aid, *2013 KitchenAid, Maytag and Whirlpool New Design 15" & 18" Under Counter Ice Makers with Filter*, (Part No. W10444925), provides the In-Home Service Professional with information on the installation, operation, and service of these 2013 ice makers only. For specific information on the model being serviced, refer to the "Use and Care Guide," or "Tech Sheet" provided with the ice maker.

The Wiring Diagrams used in this Job Aid are typical and should be used for training purposes only. Always use the Wiring Diagram supplied with the product when servicing the ice maker.

GOALS AND OBJECTIVES

The goal of this Job Aid is to provide information that will enable the In-Home Service Professional to properly diagnose malfunctions and repair the New Design 15" & 18" Under Counter Ice Makers with Filter. The objectives of this Job Aid are to:

- Understand and follow proper safety precautions.
- Recognize installation.
- Successfully access components.
- Successfully troubleshoot and diagnose malfunctions.
- Successfully perform necessary repairs.
- Successfully return the ice maker to its proper operational status.

WHIRLPOOL CORPORATION assumes no responsibility for any repairs made on our products by anyone other than authorized In-Home Service Professionals.

TABLE OF CONTENTS

SECTION 1 - GENERAL INFORMATION

Ice Maker Safety	1-2
Model Numbers	1-4
Model & Serial Number Label	1-5
Tech Sheet Location	1-5
Dimensions	1-6

SECTION 2 - INSTALLATION

Ice Maker Safety	2-2
Unpack the Ice Maker	2-3
Location Requirements	2-3
Electrical Requirements	2-4
Water Supply Requirements	2-4
Vacation or Extended Time Without Use	2-4
Connect Water Supply	2-4
Ice Maker Drain Pump Installation (on some models)	2-5
Drain Connection	2-8
Ice Maker Door Reversal - Side Swing Only	2-9
Leveling	2-11
Cleaning	2-11

SECTION 3 - CONTROLS AND OPERATING INSTRUCTIONS

User Guide by Brand	
Jenn-Air	3-2
Operating Your Ice Maker	3-2
Caring For Your Ice Maker	3-4
Accessories	3-5
Problem Solver	3-6
Performance Data Sheet	3-8
Warranty	3-9
KitchenAid	3-10
Operating Your Ice Maker	3-10
Caring For Your Ice Maker	3-12
Accessories	3-13
Problem Solver	3-14
Performance Data Sheet	3-16
Warranty	3-17
Maytag	3-18
Operating Your Ice Maker	3-18
Caring For Your Ice Maker	3-20
Accessories	3-21
Problem Solver	3-22
Performance Data Sheet	3-24
Warranty	3-25
Whirlpool.....	3-26
Operating Your Ice Maker	3-26
Caring For Your Ice Maker	3-28
Accessories	3-29
Problem Solver	3-30
Performance Data Sheet	3-32
Warranty	3-33

SECTION 4 - THEORY OF OPERATION

Operating System	4-2
Refrigeration System	4-2
Water System	4-4
Electrical System	4-4
Operational Modes	4-5

SECTION 5 - COMPONENT ACCESS

Front Grille Components	5-2
Ice Bin Components	5-3
Ice Maker Top Components	5-7
Machine Compartment Components	5-10

SECTION 6 - DIAGNOSTICS AND TROUBLESHOOTING

Safety	6-2
Service Diagnostics	6-3
Troubleshooting	6-8

SECTION 7 - REFRIGERANT RECOVERY AND CHARGING PROCEDURES

Sealed System Repair	7-2
Representative Examples of Equipment, Tools and Supplies	7-3
Equipment, Tools and Supplies	7-3
Key Components	7-4
Phase One: Initial Hook Up	7-5
Phase Two: Refrigerant Recovery	7-7
Phase Three: Make Repairs	7-8
Phase Four: Evacuation	7-9
Phase Five: Charging	7-11

PRODUCT SPECIFICATIONS & WARRANTY INFORMATION SOURCES (inside back cover)

Section 1: General Information

This section provides general information concerning Design 15" and 18" Ice Makers.

- Ice Maker Safety
- Model Numbers
- Model & Serial Number Label
- Tech Sheet Location
- Dimensions

GENERAL INFORMATION

Ice Maker Safety

Your safety and the safety of others are very important.

We have provided many important safety messages in this manual and on your appliance. Always read and obey all safety messages.



This is the safety alert symbol.

This symbol alerts you to potential hazards that can kill or hurt you and others.

All safety messages will follow the safety alert symbol and either the word "DANGER" or "WARNING."

These words mean:

⚠ DANGER

You can be killed or seriously injured if you don't immediately follow instructions.

⚠ WARNING

You can be killed or seriously injured if you don't follow instructions.

All safety messages will tell you what the potential hazard is, tell you how to reduce the chance of injury, and tell you what can happen if the instructions are not followed.

IMPORTANT SAFETY INSTRUCTIONS

WARNING: To reduce the risk of fire, electric shock, or injury when using your ice maker, follow these basic precautions:

- Plug into a grounded 3 prong outlet.
- Do not remove ground prong.
- Do not use an adapter.
- Do not use an extension cord.
- Disconnect power before manually cleaning the inside components.
- Disconnect power before servicing.
- Replace all parts and panels before operating.
- Use two or more people to move and install ice maker.

SAVE THESE INSTRUCTIONS

State of California Proposition 65 Warnings:

WARNING: This product contains one or more chemicals known to the State of California to cause cancer.

WARNING: This product contains one or more chemicals known to the State of California to cause birth defects or other reproductive harm.

Ice Maker Safety (cont.)

⚠ WARNING

Excessive Weight Hazard
 Use two or more people to move and install ice maker.
 Failure to do so can result in back or other injury.

⚠ WARNING



Electrical Shock Hazard
 Plug into a grounded 3 prong outlet.
 Do not remove ground prong.
 Do not use an adapter.
 Do not use an extension cord.
 Failure to follow these instructions can result in death, fire, or electrical shock.

⚠ WARNING



Electrical Shock Hazard
 Disconnect power before servicing.
 Replace all parts and panels before operating.
 Failure to do so can result in death or electrical shock.

⚠ DANGER



Electrical Shock Hazard
 Only authorized technicians should perform diagnostic voltage measurements.
 After performing voltage measurements, disconnect power before servicing.
 Failure to follow these instructions can result in death or electrical shock.

Voltage Measurement Safety Information

When performing live voltage measurements, you must do the following:

- Verify the controls are in the off position so that the appliance does not start when energized.
- Allow enough space to perform the voltage measurements without obstructions.
- Keep other people a safe distance away from the appliance to prevent potential injury.
- Always use the proper testing equipment.
- After voltage measurements, always disconnect power before servicing.

Model Numbers

2013 NEW DESIGN ICE MAKERS WITH FILTER
JENN-AIR, KITCHENAID, MAYTAG, WHIRLPOOL

JENN AIR 15" – JIM158XYCX, JIM158XYRS

KITCHENAID 15" – KUIC15NHZS, KUIC15PHZS, KUIC15NPOZP,
KUIC15NNZB, KUIC15NNZW

KITCHENAID 18" – KUIS18NNZB, KUIS18NNZW, KUIC18NNZS,
KUIS18PNZB, KUIS18PNZW, KUIS18PNZS

KITCHENAID 18" OUTDOOR – KUIO18NNZS

MAYTAG 15" – MIM1554ZRS, MIM1555ZRS,

WHIRLPOOL 15" – GI15NDXZS, GI15NDXZB, GI15NDXZQ

*All Colors, Introductory Models

Model & Serial Number Label

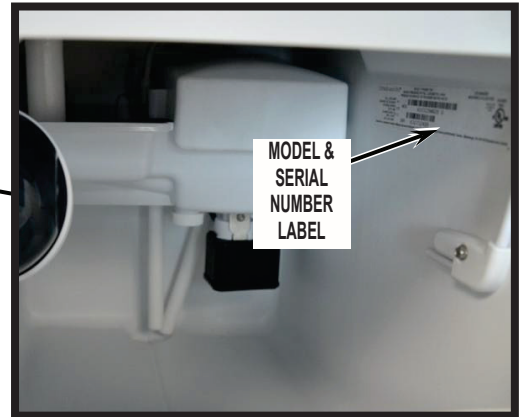
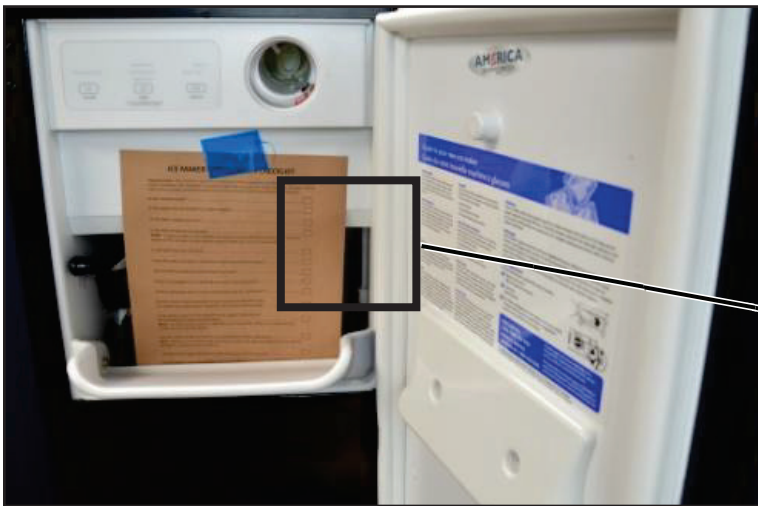

Tech Sheet Location

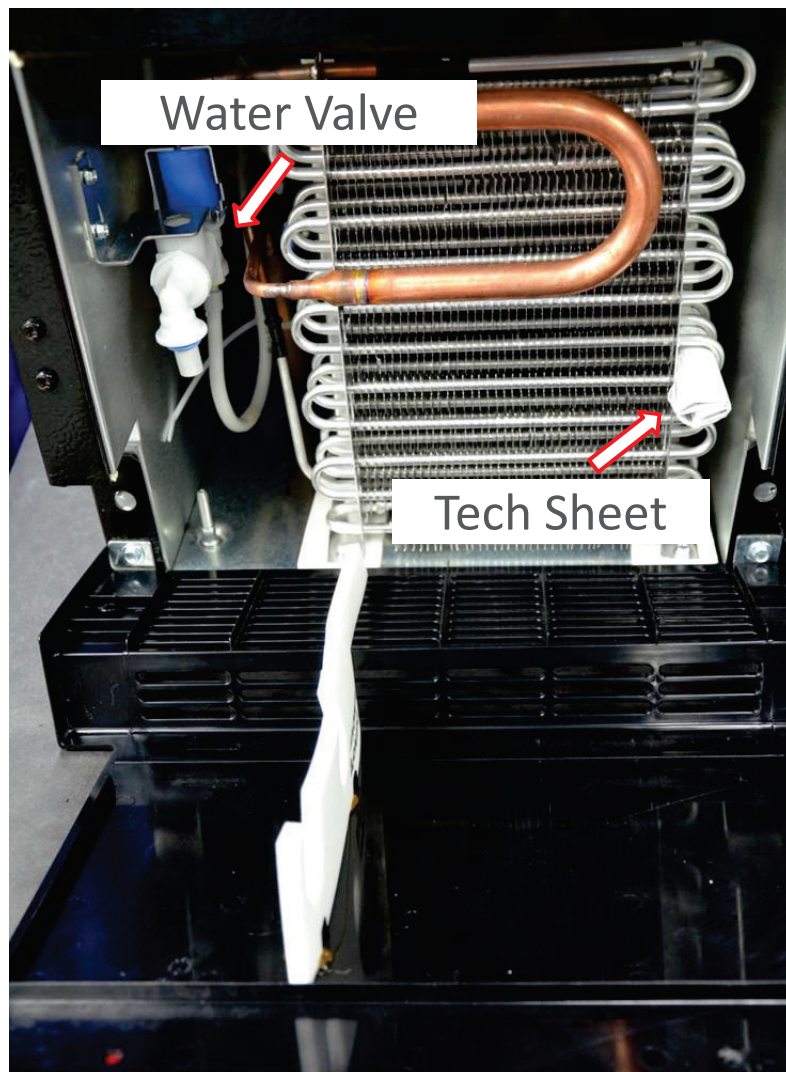

GENERAL INFORMATION

Dimensions

15" Dimensions	Inches
Carton Depth	28 1/2
Carton Height	36 3/8
Carton Width	17 3/8
Cutout Depth (in)	24
Cutout Height (in)	34
Cutout Width (in)	15
Depth	23 1/8
Height	34 3/8
Width	14 7/8
Depth Closed Excluding Handles	23 1/8
Depth Excluding Doors	21 1/2
Depth With Door Open 90 Degree	36 7/8
Gross Weight	98
Maximum Height	34 3/8
Minimum Height	33 7/8
Net Weight	90
Offset Cabinet Door Handle @90	2 5/8
Width Doors Open 90 Degrees	14 7/8
Width of Cabinet Only	14 7/8
Width with Doors Closed	14 7/8

18" Dimensions	Inches
Carton Depth	28 1/4
Carton Height	36 1/4
Carton Width	20
Cutout Depth (in)	24
Cutout Height (in)	34
Cutout Width (in)	18
Depth	24 3/8
Height	17 7/8
Width	23 1/4
Depth Closed Excluding Handles	24 3/8
Depth Excluding Doors	21 1/2
Depth With Door Open 90 Degree	44 1/8
Gross Weight	98
Maximum Height	34 3/8
Minimum Height	33 7/8
Net Weight	90
Width of Cabinet Only	17 7/8

Notes

Section 2: Installation

This section provides installation information concerning 2013 New Design 15" and 18" Ice Makers.

- Ice Maker Safety
- Unpack the Ice Maker
- Location Requirements
- Electrical Requirements
- Water Supply Requirements
- Vacation or Extended Time Without Use
- Connect Water Supply
- Ice Maker Drain Pump Installation (on some models)
- Drain Connection
- Ice Maker Door Reversal—Side Swing Only
- Leveling
- Cleaning

ICE MAKER INSTALLATION INSTRUCTIONS

Table of Contents

ICE MAKER SAFETY.....2-2
INSTALLATION INSTRUCTIONS2-3
 Unpack the Ice Maker2-3
 Location Requirements2-3
 Electrical Requirements2-4
 Water Supply Requirements2-4
 Vacation or Extended Time Without Use.....2-4
 Connect Water Supply2-4
 Ice Maker Drain Pump Installation2-5
 Drain Connection2-8
 Ice Maker Door Reversal—Side Swing Only2-9
 Leveling2-11
 Cleaning.....2-11

ICE MAKER SAFETY

Your safety and the safety of others are very important.

We have provided many important safety messages in this manual and on your appliance. Always read and obey all safety messages.



This is the safety alert symbol.

This symbol alerts you to potential hazards that can kill or hurt you and others.

All safety messages will follow the safety alert symbol and either the word “DANGER” or “WARNING.”

These words mean:

DANGER

You can be killed or seriously injured if you don't immediately follow instructions.

WARNING

You can be killed or seriously injured if you don't follow instructions.

All safety messages will tell you what the potential hazard is, tell you how to reduce the chance of injury, and tell you what can happen if the instructions are not followed.

IMPORTANT SAFETY INSTRUCTIONS

WARNING: To reduce the risk of fire, electric shock, or injury when using your ice maker, follow these basic precautions:

- Plug into a grounded 3 prong outlet.
- Do not remove ground prong.
- Do not use an adapter.
- Do not use an extension cord.
- Disconnect power before cleaning.
- Disconnect power before servicing.
- Replace all parts and panels before operating.
- Use two or more people to move and install ice maker.

SAVE THESE INSTRUCTIONS

State of California Proposition 65 Warnings:

WARNING: This product contains one or more chemicals known to the State of California to cause cancer.

WARNING: This product contains one or more chemicals known to the State of California to cause birth defects or other reproductive harm.

INSTALLATION INSTRUCTIONS

Unpack the Ice Maker

WARNING

Excessive Weight Hazard

Use two or more people to move and install ice maker.
Failure to do so can result in back or other injury.

Removing Packaging Materials

Remove tape and glue from your ice maker before using.

- To remove any remaining tape or glue from the exterior of the ice maker, rub the area briskly with your thumb. Tape or glue residue can also be easily removed by rubbing a small amount of liquid dish soap over the adhesive with your fingers. Wipe with warm water and dry.
- Do not use sharp instruments, rubbing alcohol, flammable fluids, or abrasive cleaners to remove tape or glue. Do not use chlorine bleach on the stainless steel surfaces of the ice maker. These products can damage the surface of your ice maker.

Cleaning Before Use

After you remove all of the packaging materials, clean the inside of your ice maker before using it. See the cleaning instructions in the “Ice Maker Care” section.

Location Requirements

- To ensure proper ventilation for your ice maker, the front side must be completely unobstructed. The ice maker may be closed-in on the top and three sides, but the installation should allow the ice maker to be pulled forward for servicing if necessary.
- Installation of the ice maker requires a cold water supply inlet of 1/4" (6.35 mm) OD soft copper tubing with a shutoff valve or a Whirlpool supply line Part Number 8212547RB, and a Whirlpool approved drain pump, Part Number 1901A, only to carry the water to an existing drain.

- Choose a well ventilated area with temperatures above 55°F (13°C) and below 110°F (43°C). Best results are obtained between 70°F and 90°F (21°C and 32°C).
- The ice maker must be installed in an area sheltered from the elements, such as wind, rain, water spray, or drip.
- When installing the ice maker under a counter, follow the recommended opening dimensions shown. Place electrical and plumbing fixtures in the recommended location as shown.

NOTES:

- Check that the power supply cord is not damaged, or pinched or kinked between the ice maker and the cabinet.
- Check that the water supply line is not damaged, or pinched or kinked between the ice maker and the cabinet.
- Check that the drain line (on some models) is not damaged, or pinched or kinked between the ice maker and the cabinet.
- Check that the ice maker door is not flush with the front of standard cabinets to avoid problems with opening the ice maker door.

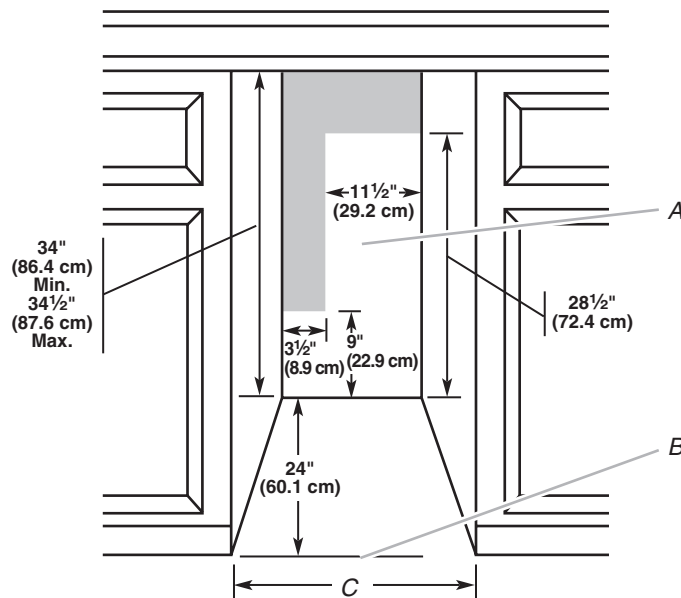

A. Recommended location for electrical and plumbing fixtures
B. Floor level
C. 15" or 18" (38.1 cm or 45.7 cm) depending on model

- Choose a location where the floor is even. It is important for the ice maker to be level in order to work properly. If needed, you can adjust the height of the ice maker by changing the height of the leveling legs. See “Leveling.”

INSTALLATION

Electrical Requirements

⚠ WARNING



Electrical Shock Hazard

Plug into a grounded 3 prong outlet.

Do not remove ground prong.

Do not use an adapter.

Do not use an extension cord.

Failure to follow these instructions can result in death, fire, or electrical shock.

Before you move your ice maker into its final location, it is important to make sure you have the proper electrical connection:

A 115 volt, 60 Hz., AC only, 15- or 20-amp electrical supply, properly grounded in accordance with the National Electrical Code and local codes and ordinances, is required.

It is recommended that a separate circuit, serving only your ice maker, be provided. Use a receptacle which cannot be turned off by a switch or pull chain.

IMPORTANT: If this product is connected to a GFCI (Ground Fault Circuit Interrupter) equipped outlet, nuisance tripping of the power supply may occur, resulting in loss of cooling. Ice quality may be affected. If nuisance tripping has occurred, and if the condition of the ice appears poor, dispose of it.

Recommended Grounding Method

The ice maker must be grounded. The ice maker is equipped with a power supply cord having a 3 prong grounding plug. The cord must be plugged into a mating, 3 prong, grounding-type wall receptacle, grounded in accordance with the National Electrical Code and local codes and ordinances. If a mating wall receptacle is not available, it is the personal responsibility of the customer to have a properly grounded, 3 prong wall receptacle installed by a qualified electrician.

Water Supply Requirements

Check that the water supply lines are insulated against freezing conditions. Ice formations in the supply lines can increase water pressure and damage your ice maker or home. Damage from frozen supply lines is not covered by the warranty.

A cold water supply with water pressure of between 30 and 120 psi (207 and 827 kPa) is required to operate the ice maker. If you have questions about your water pressure, call a licensed, qualified plumber.

Reverse Osmosis Water Supply

IMPORTANT:

- A reverse osmosis system is not recommended for ice makers that have a drain pump installed.
- For gravity drain systems only.

- The pressure of the water supply coming out of a reverse osmosis system going to the water inlet valve of the ice maker needs to be between 30 and 120 psi (207 and 827 kPa).

If a reverse osmosis water filtration system is connected to your cold water supply, the water pressure to the reverse osmosis system needs to be a minimum of 40 to 60 psi (276 to 414 kPa).

NOTE: The reverse osmosis system must provide 1 gal. (3.8 L) of water per hour to the ice maker for proper ice maker operation. If a reverse osmosis system is desired, only a whole-house capacity reverse osmosis system, capable of maintaining the steady water supply required by the ice maker, is recommended. Faucet capacity reverse osmosis systems are not able to maintain the steady water supply required by the ice maker.

If the water pressure to the reverse osmosis system is less than 40 to 60 psi (276 to 414 kPa):

- Check to see whether the sediment filter in the reverse osmosis system is blocked. Replace the filter if necessary.
- Allow the storage tank on the reverse osmosis system to refill after heavy usage.

If you have questions about your water pressure, call a licensed, qualified plumber.

Vacation or Extended Time Without Use

- When you will not be using the ice maker during the summer months, turn off the water and power supply to the ice maker.
- Make sure the water supply lines are protected against freezing conditions. Ice formations in the supply lines can increase water pressure and cause damage to your ice maker or home. Damage from freezing is not covered by the warranty.

Connect Water Supply

Read all directions before you begin.

IMPORTANT:

- Plumbing shall be installed in accordance with the International Plumbing Code and any local codes and ordinances.
- Use copper tubing or Whirlpool supply line, Part Number 8212547RP, and check for leaks.
- Install tubing only in areas where temperatures will remain above freezing.

Tools Needed

Gather the required tools and parts before starting installation:

- Flat-blade screwdriver
- $\frac{7}{16}$ " and $\frac{1}{2}$ " open-end wrenches or two adjustable wrenches
- $\frac{1}{4}$ " nut driver

NOTE: Do not use a piercing-type or $\frac{3}{16}$ " (4.76 mm) saddle valve which reduces water flow and clogs more easily.

Connecting the Water Line

1. Turn off main water supply. Turn on nearest faucet long enough to clear line of water.
2. Using a $\frac{1}{2}$ " copper supply line with a quarter-turn shutoff valve or the equivalent, connect the ice maker as shown.

NOTE: To allow sufficient water flow to the ice maker a minimum $\frac{1}{2}$ " diameter home supply line is recommended.

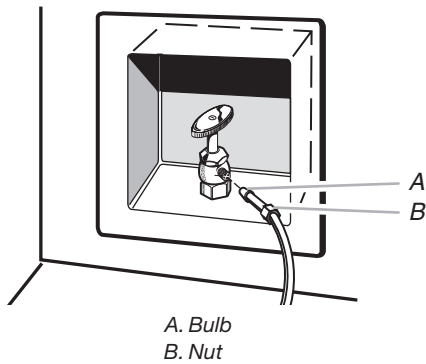

- Now you are ready to connect the copper tubing. Use $\frac{1}{4}$ " (6.35 mm) OD soft copper tubing for the cold water supply.
 - Ensure that you have the proper length needed for the job. Be sure both ends of the copper tubing are cut square.
 - Slip compression sleeve and compression nut on copper tubing as shown. Insert end of tubing into outlet end squarely as far as it will go. Screw compression nut onto outlet end with adjustable wrench. Do not overtighten.

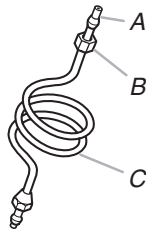

- Place the free end of the tubing into a container or sink, and turn on main water supply and flush out tubing until water is clear. Turn off shutoff valve on the water pipe.

IMPORTANT: Always drain the water line before making the final connection to the inlet of the water valve to avoid possible water valve malfunction.
- Bend the copper tubing to meet the water line inlet which is located on the back of the ice maker cabinet as shown. Leave a coil of copper tubing to allow the ice maker to be pulled out of the cabinet or away from the wall for service.

Rear View

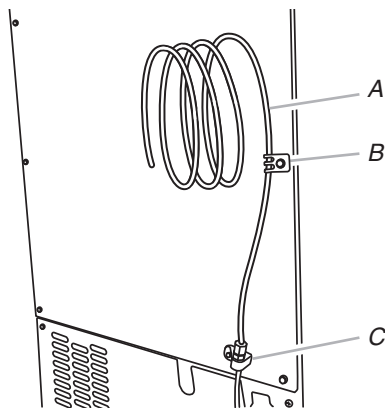

- Remove and discard the short, black plastic tube from the end of the water line inlet.
- Thread the nut onto the end of the tubing. Tighten the nut by hand. Then tighten it with a wrench two more turns. Do not overtighten.

NOTE: To avoid rattling, be sure the copper tubing does not touch the cabinet's side wall or other parts inside the cabinet.

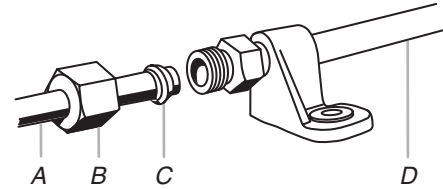

- Install the water supply tube clamp around the water supply line to reduce strain on the coupling.
- Turn shutoff valve ON.
- Check for leaks. Tighten any connections (including connections at the valve) or nuts that leak.

Ice Maker Drain Pump Installation (on some models)

NOTES:

- Connect drain pump to your drain in accordance with all state and local codes and ordinances.
- It may be desirable to insulate drain tube thoroughly up to drain inlet to minimize condensation on the drain tube. Insulated tube kit Part Number W10365792 is available for purchase.
- Drain pump is designed to pump water to a maximum height of 10 ft (3 m). Use only Whirlpool approved drain pump kit Part Number 1901A.
- Do not connect outlet end of drain tube to a closed pipe system to keep drain water from backing up into the ice maker.

Kit Contains:

- Drain pump kit Part Number 1901A
- $\frac{5}{8}$ " ID x $5\frac{1}{8}$ " drain tube (ice maker bin to drain pump reservoir inlet)
- $\frac{1}{2}$ " ID x 10 ft (3 m) drain tube hose (drain pump discharge to household drain)
- $\frac{5}{16}$ " ID x 32" (81 cm) vent tube (drain pump reservoir vent to ice maker cabinet back)
- Cable clamps (secures vent tube to back of ice maker) (3)
- #8-32 x $\frac{3}{8}$ " pump mounting screws (secures drain pump to baseplate and clamps to back of ice maker) (5)
- $\frac{5}{8}$ " small adjustable hose clamp (secures vent to drain pump)
- $\frac{7}{8}$ " large adjustable hose clamp, (secures drain tube to ice maker bin and drain pump reservoir inlet) (3)
- Rear panel (2)
- Instruction sheet

INSTALLATION

If Ice Maker Is Currently Installed

NOTE: If ice maker is not installed, please proceed to “Drain Pump Installation” section.

1. Push the selector switch to the Off position.

⚠ WARNING



Electrical Shock Hazard

Disconnect power before servicing.

Replace all parts and panels before operating.

Failure to do so can result in death or electrical shock.

2. Unplug ice maker or disconnect power.
3. Turn off water supply. Wait 5 to 10 minutes for the ice to fall into the storage bin. Remove all ice from bin.
4. Unscrew the drain cap from the bottom of the water pan located inside the storage bin. Allow water to drain completely. Replace drain cap. See “Drain Cap” illustration.

Drain Cap

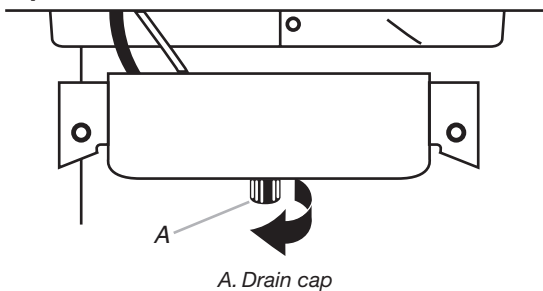

5. If ice maker is built into cabinets, pull ice maker out of the opening.
6. Disconnect water supply line. See “Water Supply Line” illustration.

Water Supply Line

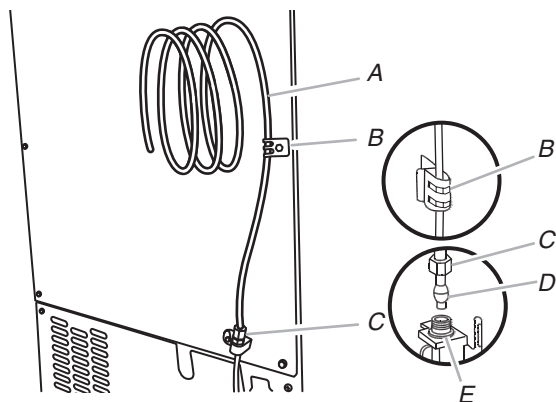

- | | |
|-------------------------|-------------------------|
| A. 1/4" copper tubing | D. Ferrule (sleeve) |
| B. Cable clamp | E. Ice maker connection |
| C. 1/4" compression nut | |

Drain Pump Installation

NOTE: Do not kink, smash or damage tubes or wires during installation.

1. Unplug ice maker or disconnect power.
2. Remove rear panel. See “Rear Panel” illustration for 5 screw locations. Pull rear panel away from the drain tube and discard.

Rear Panel

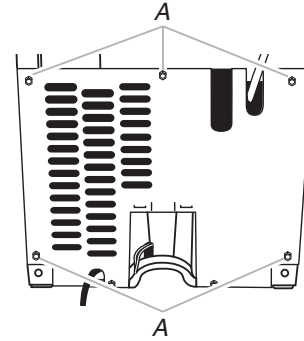

A. Screw locations

3. Remove the old drain tube and clamp attached to the ice maker bin.

NOTE: Discard old drain tube and clamp.
4. Install new drain tube (5/8" ID x 5 1/8") from ice maker bin to drain pump reservoir inlet using new adjustable clamps. See “Drain Tube” illustration.

NOTES:

- Do not kink.
- Trim tube length, if required.

Drain Tube

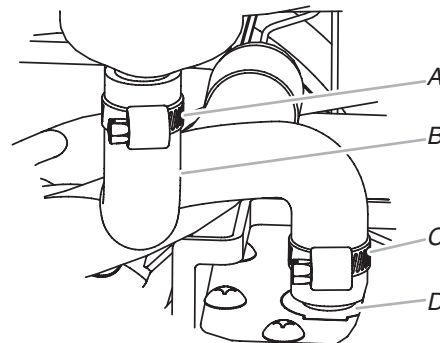

- | | |
|---------------------------------------|-------------------------------|
| A. 7/8" adjustable hose clamp | C. 7/8" adjustable hose clamp |
| B. Drain tube (ice bin to drain pump) | D. Drain pump reservoir inlet |

5. Install vent tube (5/16" ID x 32" [81 cm]) to drain pump reservoir vent. Use one 5/8" small adjustable clamp, supplied. See “Parts Locations” illustration.

NOTE: Do not install household drain tube at this time.

Parts Locations

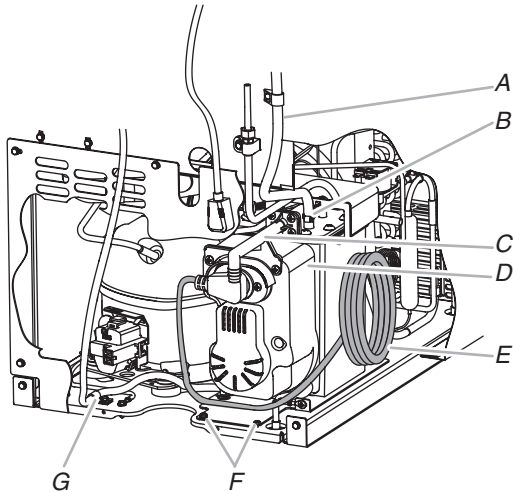

- A. Vent tube
- B. 5/8" hose clamp
- C. Drain pump discharge tube
- D. Drain pump
- E. Ice maker unit power cord
- F. #8-32 x 3/8" pump mounting screws
- G. Drain pump power cord, clamp and screw

6. Remove power cord clamp and ground screw attached to ice maker power cord, which is mounted to the unit base. See "Parts Locations" illustration.

NOTE: Clamp and screw will be reused.

7. Slide drain pump into the ice maker base on the right side. The pump mounting tab should slip into the rectangular slot in the ice maker base. It will be necessary to tip the pump slightly to slip into the slot. See "Drain Pump Mounting Tab Slot" illustration.

Drain Pump Mounting Tab Slot

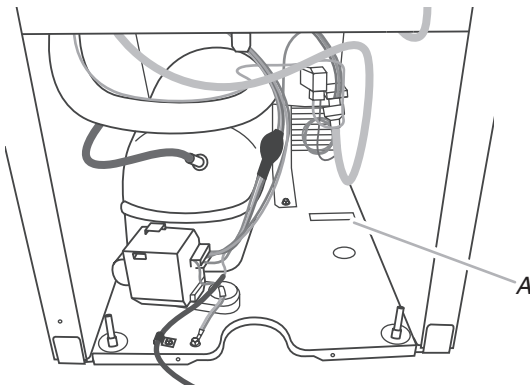

A. Mounting tab slot

Drain Pump Installed

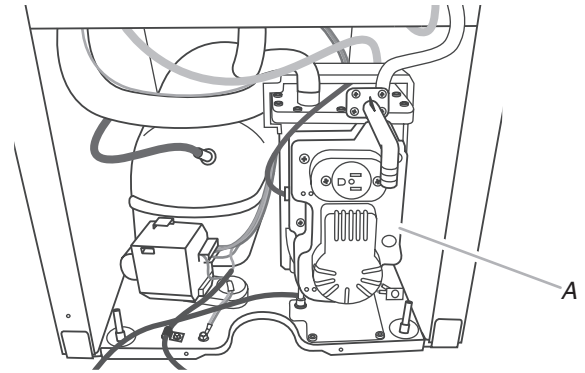

A. Drain pump installed

8. Align the 2 screw holes at the rear of the pump. Use two #8-32 x 3/8" screws, supplied. See "Parts Locations" illustration.
9. Connect drain tube to ice maker bin outlet (5/8" ID), using 7/8" adjustable clamp, supplied. See "Drain Tube" illustration.
10. Coil ice maker power cord into a 4" (10.2 cm) diameter coil. Wrap electrical tape around the power cord in several places to keep the cord in a coil. Locate coiled power cord between the drain pump and side of enclosure and plug into the receptacle of the drain pump. See "Parts Locations" illustration.
11. Attach the drain pump power cord to ice maker unit base with clamp and screw (removed in Step 6) that was used to attach ice maker power cord. See "Parts Locations" illustration.
12. Place new rear panel (small one for 15" ice makers, large one for 18") against the back of the ice maker. Route the vent tube and drain pump discharge tube through cutouts in the rear panel.
13. Secure rear panel with original screws. See "Rear Panel" illustration.
14. Secure vent tube to back of ice maker using 3 clamps and three #8-32 x 3/8" screws, supplied. See "Vent Tube" illustration.

Vent Tube

NOTE: Do not pinch, kink or damage the vent tube. Check that it is not damaged, or pinched or kinked between the cabinet and the ice maker.

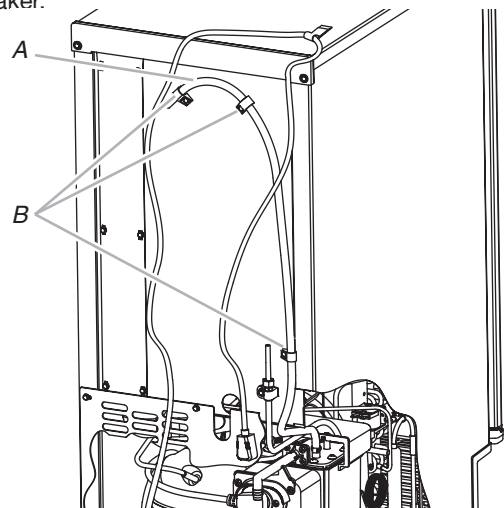

A. Vent tube
B. Clamps and screws

INSTALLATION

15. Attach ½" ID x 10 ft (3 m) drain tube to pump discharge tube. See "Parts Locations" illustration.
NOTE: Do not connect outlet end of drain tube to a closed pipe system to keep drain water from backing up into the ice maker.
16. Connect ice maker to water supply and install ice maker as specified by the product installation instructions.
17. Check all connections for leaks.

⚠ WARNING



Electrical Shock Hazard

Plug into a grounded 3 prong outlet.

Do not remove ground prong.

Do not use an adapter.

Do not use an extension cord.

Failure to follow these instructions can result in death, fire, or electrical shock.

18. Plug in ice maker or reconnect power.
19. Turn on ice maker.
20. Wait for rinsing cycle, approximately 5 minutes, to be sure the ice maker is operating properly.

Drain Connection

Gravity Drain System

Connect the ice maker drain to your drain in accordance with all state and local codes and ordinances. If the ice maker is provided with a gravity drain system, follow these guidelines when installing drain lines. This will help keep water from flowing back into the ice maker storage bin and potentially flowing onto the floor, causing water damage.

- Drain lines must have a minimum of 5/8" (15.88 mm) inside diameter.
- Drain lines must have a 1" drop per 48" (2.54 cm drop per 122 cm) of run or ¼" drop per 12" (6.35 mm per 30.48 cm) of run and must not have low points where water can settle.
- The floor drains must be large enough to accommodate drainage from all drains.

- The ideal installation has a standpipe with a 1½" (3.81 cm) to 2" (5.08 cm) PVC drain reducer installed directly below the outlet of the drain tube as shown. You must maintain a 1" (2.54 cm) air gap between the drain hose and the standpipe.

IMPORTANT: A drain pump is necessary when a floor drain is not available. A Drain Pump kit, Part Number 1901A, is available for purchase.

Side View

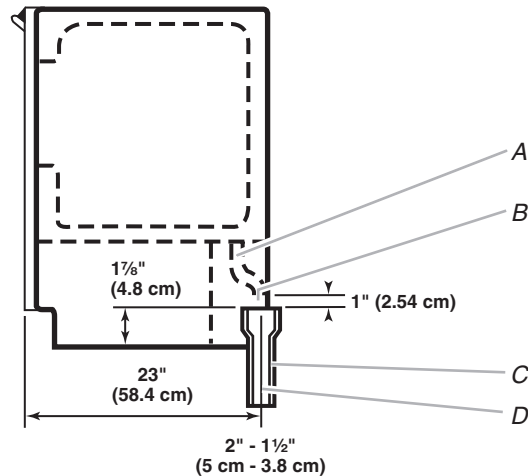

- A. Drain hose
B. 1" (2.54 cm) air gap
C. PVC drain reducer
D. Center of drain should be 23" (58.4 cm) from front of door, with or without the ¾" (1.91 cm) panel on the door. The drain should also be centered from left to right (7 5/16" [18.56 cm] from either side of the ice maker).

Drain Pump System (on some models)

IMPORTANT:

- Connect the ice maker drain to your drain in accordance with the International Plumbing Code and any local codes and ordinances.
- The drain pump discharge line must terminate at an open sited drain.
 - Maximum rise 10 ft (3.1 m)
 - Maximum run 100 ft (30.5 m)

NOTES:

- If the drain hose becomes twisted and water cannot drain, your ice maker will not work.
- It may be desirable to insulate the drain line thoroughly up to the drain inlet. An Insulation Sleeve kit, Part Number W10365792, is available for purchase.
- Do not connect outlet end of drain tube to a closed pipe system to keep drain water from backing up into the ice maker.

Connecting the Drain

After ensuring that the drain system is adequate, follow these steps to properly place the ice maker:

⚠ WARNING



Electrical Shock Hazard

Plug into a grounded 3 prong outlet.

Do not remove ground prong.

Do not use an adapter.

Do not use an extension cord.

Failure to follow these instructions can result in death, fire, or electrical shock.

1. Plug into a grounded 3 prong outlet.

⚠ WARNING

Excessive Weight Hazard

Use two or more people to move and install ice maker.

Failure to do so can result in back or other injury.

2. **Style 1**—For gravity drain system, push the ice maker into position so that the ice maker drain tube is positioned over the PVC drain reducer. See “Gravity Drain System.”
Style 2—For drain pump system connect the drain pump outlet hose to the drain. See “Drain Pump System.”
3. Recheck the ice maker to be sure that it is level. See “Leveling.”
4. If it is required by your local sanitation code, seal the cabinet to the floor with an approved caulking compound after all water and electrical connections have been made.

Ice Maker Door Reversal—Side Swing Only

Tools Needed

Gather the required tools and parts before starting installation.

- 5/16" wrench
- Flat putty knife
- 1/4" wrench
- Phillips screwdriver

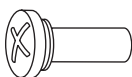

Hinge pin

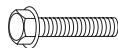

5/16" hex-head hinge screw



Handle screw

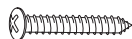

End cap screw

**Remove Stainless Steel Door Wrap Panel—
On Some Models**

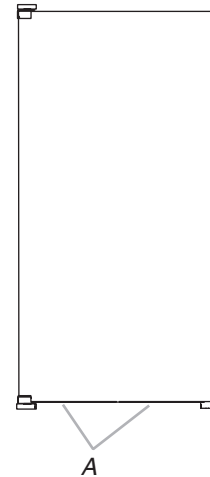

A. Hex-head screws

1. Remove the 2 hex-head screws located under the stainless steel door wrap panel flange on the bottom of the door.
2. Pull up and outward on the door wrap panel from the bottom.
3. Rotate the door wrap panel until it separates from the door and pull up.

NOTE: Be sure the edge guards do not separate from the door wrap panel.

Door Stop and End-Cap Reversal

⚠ WARNING



Electrical Shock Hazard

Disconnect power before servicing.

Replace all parts and panels before operating.

Failure to do so can result in death or electrical shock.

1. Unplug the ice maker or disconnect power.
2. Remove the handle screws and handle (on some models).
3. Remove the hinge pin from the top hinge.
4. Remove the door from the hinges and replace the top hinge pin.
5. Remove the screw and door stop at corner A. Remove the screw and end cap at corner C. Place the door stop at corner C, and tighten screw. Place the end cap at corner A, and tighten screw.

INSTALLATION

- Remove the screw and door stop at corner D. Remove the screw and end cap at corner B. Place the door stop at corner B, and tighten screw. Place the end cap at corner D, and tighten screw.

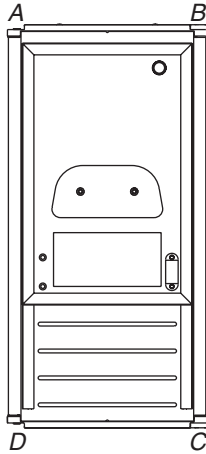

- A. Top corner open (no end cap) C. Beginning bottom corner end cap
B. Beginning top corner end cap D. Bottom corner open (no end cap)

- Depending on your model, the brand badge for the front door of your ice maker may be in the package with the Use and Care Guide. Fasten the brand badge to the door.
- Set the door aside.

Reverse Hinges

- Unscrew and remove the top hinge. Replace the screws in the empty hinge holes.
- Remove the screws from the bottom of the opposite side of the ice maker cabinet. Turn the top hinge upside down so that the hinge pin points up. Place the hinge on the bottom opposite side of the ice maker and tighten screws.
- Remove the "old" bottom hinge screws and hinge. Replace the screws in the empty hinge holes.
- Remove the screws from the top of the opposite side of the ice maker cabinet. Turn the hinge upside down so that the hinge pin points down. Place the hinge on the top opposite side of the ice maker and tighten the screws.
- Remove the top hinge pin.

Replace Door

- Place the door on the bottom hinge pin.
- Align the door with the top hinge hole and replace the top hinge pin.
- Replace the handle and handle screws.

On Some Models—Replace Door Wrap

- Place the door wrap flange onto the door top and ensure that it fits correctly.
- Rotate the door wrap downward until it covers the door surface completely.
- Install the 2 hex-head screws into the bottom of the door.

Top Hinge

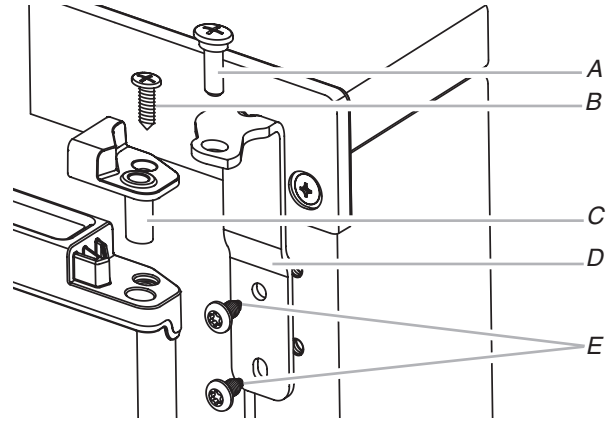

- A. Hinge pin D. Hinge
B. Phillips-head countersink screw E. Hex-head hinge screw
C. Hinge pin sleeve

Bottom Hinge

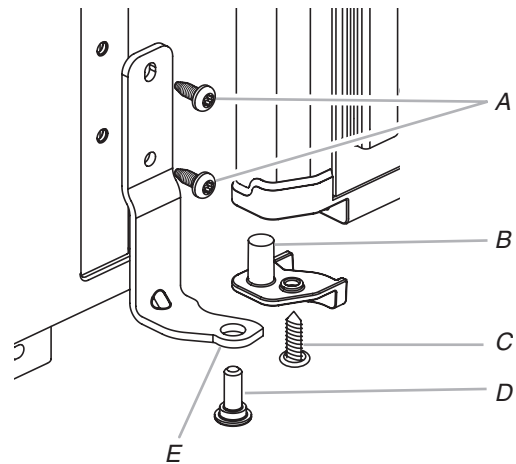

- A. Hex-head hinge screw D. Hinge pin
B. Hinge pin sleeve E. Hinge
C. Phillips-head countersink screw

Reverse Door Catch

- Remove the white decorative screws from the opposite side of the door and set aside.
- Remove the screws from the magnetic door catch and replace it on the opposite side of the door.

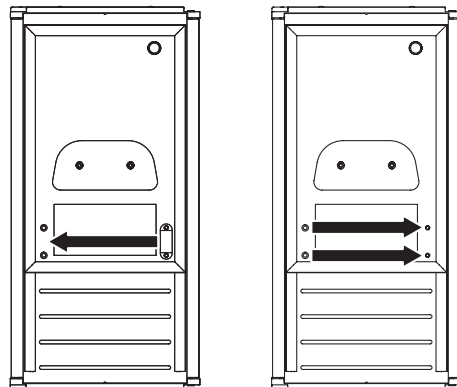

3. Install the white decorative screws on the opposite side of the door.

⚠ WARNING



Electrical Shock Hazard

Plug into a grounded 3 prong outlet.

Do not remove ground prong.

Do not use an adapter.

Do not use an extension cord.

Failure to follow these instructions can result in death, fire, or electrical shock.

4. Plug into a grounded 3 prong outlet.

Leveling

It is important for the ice maker to be level in order to work properly. Depending upon where you install the ice maker, you may need to make several adjustments to level it. You may also use the leveling legs to lower the height of the ice maker for undercounter installations.

Tools Needed

Gather the required tools and parts before starting installation.

- 9" level
- Adjustable wrench

NOTE: It is easier to adjust the leveling legs if you have another person to assist you.

1. Move the ice maker to its final location.

NOTE: If this is a built-in installation, move the ice maker as close as possible to the final location.
2. Place the level on top of the product to see whether the ice maker is level from front to back and side to side.
3. Push up on the top front of the ice maker, and then locate the leveling screws that are on the bottom front of the ice maker.
4. Using an adjustable wrench, change the height of the legs as follows:
 - Turn the leveling leg to the right to lower that side of the ice maker.
 - Turn the leveling leg to the left to raise that side of the ice maker.

NOTE: The ice maker should not wobble. Use shims to add stability when needed.

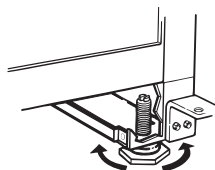

5. Push up on the top rear of the ice maker and locate the leveling legs that are on the bottom rear of the ice maker.
6. Follow the instructions in Step 4 to change the height of the legs.
7. Use the level to recheck the ice maker to see that it is even from front to back and side to side. If the ice maker is not level, repeat steps 2 to 5. If the ice maker is level, go to the "Connect Water Supply" section.

Cleaning

Interior Components

1. Unplug ice maker or disconnect power.
2. Open the storage bin door and remove any ice that is in the bin.
3. Remove the drain cap from the water pan and drain thoroughly. Replace the drain cap securely on the water pan. If the drain cap is loose, water will empty from the water pan, and you will have either thin ice or no ice.
4. Pull out on the bottom of the cutter grid cover until the snaps release to remove.

NOTE: On some models, remove the screw from the cutter grid cover.
5. Unplug the wiring harness from the left side of the cutter grid.

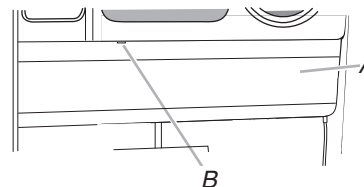

A. Cutter grid cover
B. Screw (on some models)

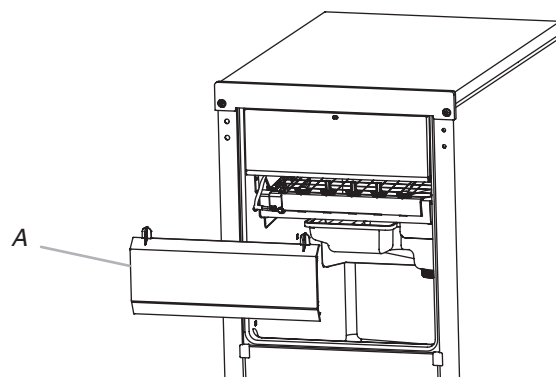

A. Cutter grid cover

INSTALLATION

6. Unplug the ice level sensor from the right side of the cutter grid. Pull the ice level sensor down and forward away from the cutter grid.
7. Remove the right-hand and left-hand screws. Lift the cutter grid up and out.

NOTE: Make sure the plastic spacer from the right-hand side of the cutter grid bracket stays with the cutter grid.

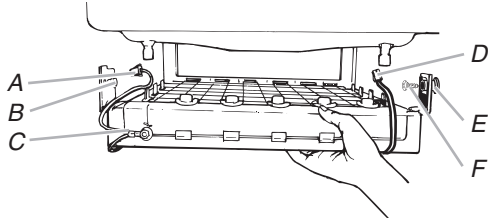

A. Cutter grid harness
B. Screw
C. Cutter grid
D. Ice level sensor harness
E. Plastic spacer
F. Screw

8. Remove the mounting screw that holds the water pan in place. Pull out on the front of the water pan.
9. Disconnect the pump bracket from the water pan and unplug the water pan drain pump.

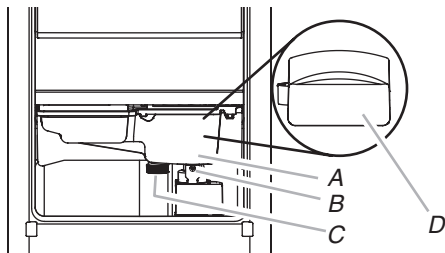

A. Water pan
B. Water pan screw
C. Drain cap
D. Drain pump cover

10. Remove, clean and replace the ice scoop holder and ice scoop.

NOTE: On some models, the ice scoop holder is located in the upper left of the unit, and on other models, the ice scoop holder is located in the lower left of the unit.

On Some Models

- Remove the holder by removing the 2 screws.
- Wash the ice scoop holder and ice scoop along with the other interior components using the following instructions.
- Replace the ice scoop holder by replacing the screws.

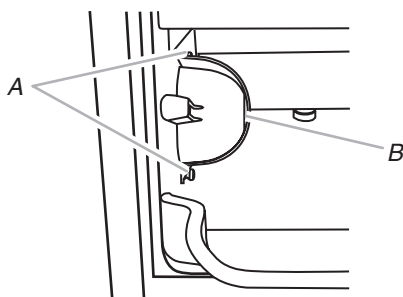

A. Screw
B. Ice scoop holder

On Some Models

- After removing the ice scoop, remove the holder by removing the 2 screws.

NOTE: On some models, remove the holder by lifting up on the ice scoop holder and then out.
- Wash the ice scoop holder along with the other interior components using the following instructions.
- Replace the ice scoop holder by replacing the screws or on some models, pushing in on the holder and then down.

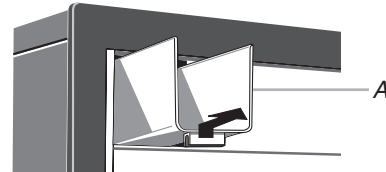

A. Ice scoop holder

11. Wash the interior components (cutter grid, exterior of hoses, and water pan) and the storage bin, door gasket, ice scoop, and ice scoop holder with mild soap or detergent and warm water. Rinse in clean water. Then clean the same parts with a solution of 1 tbs (15 mL) of household bleach in 1 gal. (3.8 L) warm water. Rinse again thoroughly in clean water.

NOTE: Do not remove hoses. Do not wash plastic parts in dishwasher. They cannot withstand temperatures above 145°F (63°C).
12. To replace the water pan, set the water pan inside the ice bin. Hook up the water pan pump. Snap the pump bracket back onto the water pan and place back into position. Secure the water pan by replacing the mounting screw.
13. Check the following:
 - Drain cap from the water pan is securely in place. If the drain cap is loose, water will empty from the water pan, and you will have either thin ice or no ice.
 - Hose from water pan is inserted into storage bin drain opening.
14. Slide the cutter grid back into place and secure it by replacing the right-hand screw and plastic spacer. Then tighten the left-hand screw. Reconnect the cutter grid harness and the ice level sensor harness.
15. Replace the cutter grid cover.

NOTE: On some models, replace the cutter grid cover using the screw removed earlier.
16. Gently wipe the control panel with a soft, clean dishcloth using warm water and a mild liquid dish detergent.
17. Plug in ice maker or reconnect power.
18. After cleaning, make sure that all controls are set properly and that no control indicators are flashing.

Section 3: Controls and Operating Instructions

This section provides operational use and care information for Design 15" and 18" Ice Makers.

- Use and Care by Brand:
 - Jenn-Air, KitchenAid, Maytag, Whirlpool
- Operating Your Ice Maker
 - How Your Ice Maker Works
 - Using the Controls
 - Water Filtration System
 - Normal Sounds
- Caring For Your Ice Maker
 - Cleaning
- Accessories
- Problem Solver
 - Ice Maker Operation
 - Ice Production
 - Ice Quality
 - Plumbing Problems
- Performance Data Sheet
- Warranty

JENN-AIR®

User Guide

Ice Maker



LEARN MORE

In an effort to conserve natural resources, this ice maker includes a condensed User Guide. A complete Use and Care Guide can be downloaded at www.jennair.com/manuals.

The model number is located on the inside of the ice maker.

Register your ice maker at www.jennair.com.

Para una version de estas instrucciones en español, visite www.jennair.com.

Your safety and the safety of others are very important.

We have provided many important safety messages in this manual and on your appliance. Always read and obey all safety messages.



This is the safety alert symbol.

This symbol alerts you to potential hazards that can kill or hurt you and others.

All safety messages will follow the safety alert symbol and either the word "DANGER" or "WARNING."

These words mean:

DANGER

You can be killed or seriously injured if you don't immediately follow instructions.

WARNING

You can be killed or seriously injured if you don't follow instructions.

All safety messages will tell you what the potential hazard is, tell you how to reduce the chance of injury, and tell you what can happen if the instructions are not followed.

IMPORTANT SAFETY INSTRUCTIONS

WARNING: To reduce the risk of fire, electric shock, or injury when using your ice maker, follow these basic precautions:

- Plug into a grounded 3 prong outlet.
- Do not remove ground prong.
- Do not use an adapter.
- Do not use an extension cord.
- Disconnect power before cleaning.
- Disconnect power before servicing.
- Replace all parts and panels before operating.
- Use two or more people to move and install ice maker.

SAVE THESE INSTRUCTIONS

State of California Proposition 65 Warnings:

WARNING: This product contains one or more chemicals known to the State of California to cause cancer.

WARNING: This product contains one or more chemicals known to the State of California to cause birth defects or other reproductive harm.

Operating Your Ice Maker

How Your Ice Maker Works

When you first start your ice maker, the water pan will fill and the system will rinse itself before starting to make ice. The rinsing process takes about 5 minutes.

Under normal operating conditions, the ice maker will cycle at preset temperatures. The ice level sensor located in the ice storage bin will monitor the ice levels.

IMPORTANT: If the water supply to the ice maker is turned off, be sure to set the ice maker control to OFF.

The Ice Making Process

1. Water is constantly circulated over a freezing plate. As the water freezes into ice, the minerals in the water are rejected. This produces a sheet of ice with a low mineral content.

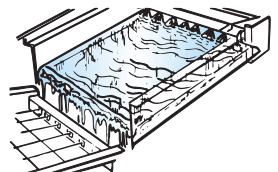

2. When the desired thickness is reached, the ice sheet is released and slides onto a cutter grid. The grid divides the sheet into individual cubes.

3. The water containing the rejected minerals is drained after each freezing cycle.

4. Fresh water enters the machine for the next ice making cycle.

5. Cubes fall into the storage bin. When the bin is full, the ice maker shuts off automatically and restarts when more ice is needed. The ice bin is not refrigerated, and some melting will occur. The amount of melting varies with room temperature.

NOTE: As the room and water temperatures vary, so will the amount of ice produced and stored. This means that higher operating temperatures result in reduced ice production.

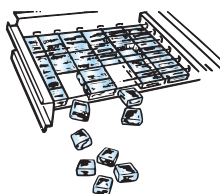
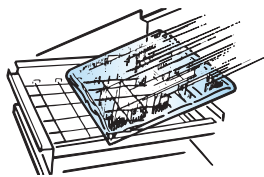

Using the Controls

1. To start ice production, press ON/OFF.
2. To stop ice maker operation, press ON/OFF.

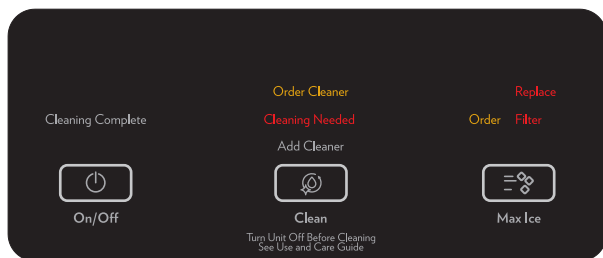

NOTES:

- Pressing the On/Off button does not shut off power to the ice maker.
- Allow 24 hours to produce the first batch of ice. Discard the first 2 batches produced.

Max Ice Mode

Select the Max Ice feature when you have an upcoming need for a large amount of ice and the ice bin is low or empty. Max Ice mode will produce a greater quantity of ice in a 24-hour period.

- Press MAX ICE while the ice maker is on. The indicator light will illuminate.
- Press MAX ICE again to turn off the Max Ice feature. The indicator light will turn off.
- The Max Ice mode will be on when you first turn on the product. It will turn off after 24 hours. To turn Max Ice back on, press MAX ICE.

Clean

It is recommended that you clean the ice maker when the "Cleaning Needed" light is illuminated or 9 months has elapsed or ice production decreases significantly. To clean your ice maker, see "Ice Maker System" in the "Cleaning" section.

Door Ajar Alarm

The Door Ajar Alarm feature sounds an alarm when the ice maker door is open for 5 minutes. The alarm will repeat every 2 minutes. Close the door to turn off. The feature then resets and will reactivate when the door is left open again for 5 minutes.

Water Filtration System

Do not use with water that is microbiologically unsafe or of unknown quality without adequate disinfection before or after the system. Systems certified for cyst reduction may be used on disinfected waters that may contain filterable cysts.

Install the Water Filter

1. Locate the accessory packet in the ice maker and remove the water filter.
2. Take the water filter out of its packaging and remove the cover from the O-rings. Be sure the O-rings are still in place after the cover is removed.

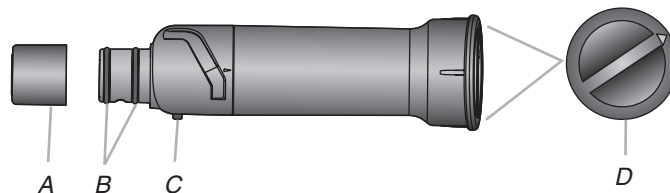

A. Cover
B. O-rings
C. Alignment pin
D. Alignment arrow

3. The water filter compartment is located in the right-hand side of the ice maker controls. Push in on the door to release the latch, and then lower the door.

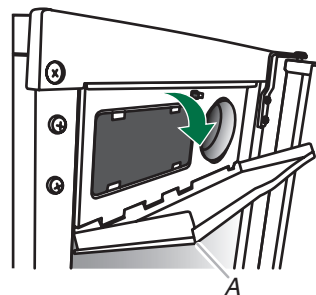

A. Door

4. Using the arrow pointing to the alignment pin on the side of the filter and the arrow inside the control housing, align the alignment pin with the cutout notch and insert the filter into the housing.

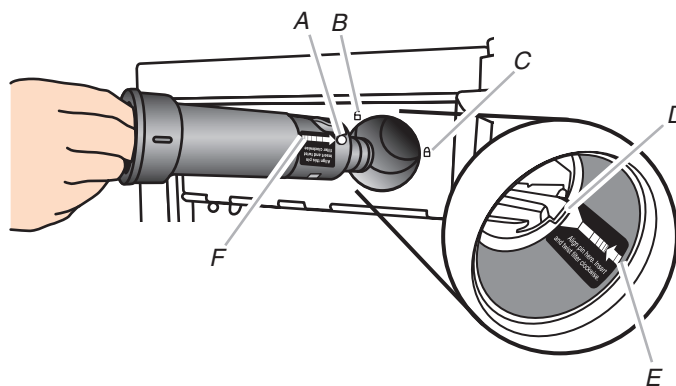

A. Alignment pin
B. Unlocked symbol
C. Locked symbol
D. Cutout notch inside control housing
E. Arrow pointing to cutout notch
F. Arrow pointing to alignment pin

CONTROLS AND OPERATING INSTRUCTIONS

- Turn the filter clockwise until it locks into the housing. Ensure that the alignment arrow on the filter head aligns with the locked symbol on the control box housing.

NOTE: If the filter is not correctly locked into the housing, the ice maker will not produce ice.

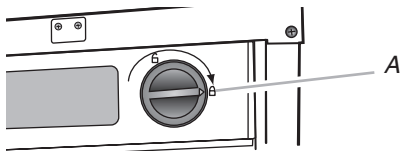

A. Alignment arrow aligned with locked symbol

- Push the control box door closed until the latch snaps closed.

The Water Filter Status Light

The water filter status lights will help you know when to change your water filter.

- The “Order Filter” status light will be illuminated when it is time to order a replacement filter.
- The “Replace Filter” status light will be illuminated when it is time to replace the filter.
- Replacing the disposable water filter with a new filter will automatically reset the filter status tracking feature. See “Using the Controls.”

NOTES:

- “Replace Filter” will remain illuminated if a filter is not installed.
- The “Filter” status light will flash if the filter is not correctly installed or there is an obstruction in the water line.

Replace the Water Filter

To purchase a replacement water filter, see “Accessories.”

Replace the disposable water filter when indicated on the water filter status display or at least every 9 months. If the ice making rate decreases before the Replace Filter light illuminates, then replace the filter.

- Locate the water filter compartment in the right-hand side of the control housing. See Step 3 in the “Install Water Filter” section.

- Turn the water filter counterclockwise (to the left), and pull it straight out of the compartment.

NOTE: There may be some water in the filter. Some spilling may occur.

- Install the replacement water filter by following steps 2 through 5 in the “Install the Water Filter” section.

Normal Sounds

Your new ice maker may make sounds that are not familiar to you. Because the sounds are new to you, you might be concerned about them. Most of the new sounds are normal. Hard surfaces such as floors, walls and cabinets can make the sounds seem louder than they actually are. The following describes the kinds of sounds that might be new to you and what may be making them.

- You will hear a buzzing sound when the water valve opens to fill the water pan for each cycle.
- Rattling noises may come from the flow of the refrigerant or the water line. Items stored on top of the ice maker can also make noises.
- The high-efficiency compressor may make a pulsating or high pitched sound.
- Water running over the evaporator plate may make a splashing sound.
- Water running from the evaporator plate to the water pan may make a splashing sound.
- As each cycle ends, you may hear a gurgling sound due to the refrigerant flowing in your ice maker.
- You may hear air being forced over the condenser by the condenser fan.
- During the harvest cycle, you may hear a “thud” when the ice sheet slides from the evaporator onto the cutter grid.
- When you first start the ice maker, you may hear water running continuously. The ice maker is programmed to run a rinse cycle before it begins to make ice.
- If the ice maker is connected to a water supply pressure in excess of 60 psi, you may hear a loud sound during water filling associated with the flow of water through the inlet valve. Call a licensed, qualified plumber to determine the best method to reduce the supply water pressure (50 psi is recommended).

Caring For Your Ice Maker

Cleaning

The ice making system and the air cooled condenser need to be cleaned regularly for the ice maker to operate at peak efficiency and to avoid premature failure of system components. See the “Ice Maker System” and the “Condenser” sections.

Exterior Surfaces

Wash the exterior enamel surfaces and gaskets with warm water and mild soap or detergent. Wipe and dry. Regular use of a good household appliance cleaner and wax will help maintain the finish. Do not use abrasive cleaners on enamel surfaces as they may scratch the finish.

For products with a stainless steel exterior, use a clean sponge or soft cloth and a mild detergent in warm water. Do not use abrasive or harsh cleaners. Do not use chlorine bleach on the stainless steel surfaces.

Ice Maker System

Minerals that are removed from water during the freezing cycle will eventually form a hard scaly deposit in the water system. Cleaning the system regularly helps remove the mineral scale buildup. How often you need to clean the system depends upon how hard your water is. With hard water of 15 to 20 grains/gal. (4 to 5 grains/liter), you may need to clean the system as often as every 9 months.

NOTE: Use one 16 oz (473 mL) bottle of approved ice maker cleaner. To order, see “Accessories.”

- Press the ON/OFF button.
- Wait 5 to 10 minutes for the ice to fall into the storage bin. Remove all ice from the storage bin.
- Unscrew the drain cap from the bottom of the water pan located inside the storage bin as shown. Allow the water to drain completely.
- Replace the drain cap securely on the water pan. If the drain cap is loose, water will empty from the water pan and you will have either thin ice or no ice.
- Read and follow all handling information on the cleaner bottle before completing the steps below. Use one 16 oz (473 mL) bottle of approved ice maker cleaner.

- Pour one bottle of solution into the water pan. Fill the bottle twice with tap water and pour it into the water pan.

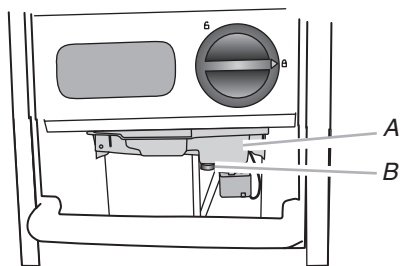

A. Water pan
B. Drain cap

- Press the CLEAN button. See “Using the Controls.” The light will blink, indicating that the cleaning cycle is in process. When the “Cleaning Complete” light is illuminated (approximately 70 minutes), the cleaning cycle is complete. During the cleaning cycle, the system will both clean and rinse itself.
- After the cleaning cycle is complete, remove the drain cap from the water pan. Look for any cleaning solution left in the water pan. If cleaning solution drains from the water pan, you should run the clean cycle again. Be sure to refill the water pan with cleaner before starting the clean cycle again. Be sure to replace the drain cap securely on the water pan. If the drain cap is loose, water will empty from the water pan and you will have either thin ice or no ice.

NOTE: Severe scale buildup may require repeated cleaning with a fresh quantity of cleaning solution.

- Press the ON/OFF button to resume ice production.

Condenser

A Dirty or Clogged Condenser

- Obstructs proper airflow.
- Reduces ice making capacity.
- Causes higher than recommended operating temperatures which may lead to component failure.

WARNING



Electrical Shock Hazard

Disconnect power before cleaning.
Replace all parts and panels before operating.
Failure to do so can result in death or electrical shock.

- Unplug ice maker or disconnect power.
- Remove the 2 screws in the lower access panel and the 2 screws from the base grille area of the front panel support.
- Pull the bottom forward and then pull down to remove the lower access panel.

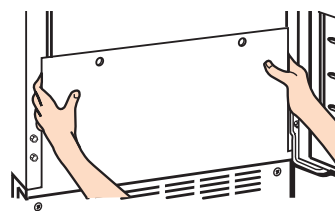

- Remove dirt and lint from the condenser fins and the unit compartment with a brush attachment on a vacuum cleaner.

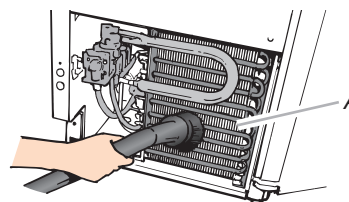

A. Condenser fins

- Replace the lower access panel using the 4 screws.
- Plug in ice maker or reconnect power.

Accessories

To order accessories, in the U.S.A., visit our website www.jennair.com/accessories or call 1-800-901-2042.

In Canada, visit our website www.whirlpoolparts.ca or call 1-800-807-6777.

Water Filter

Order Part Number F2WC9I1 or ICE2

Cleaner

Order Part Number 4396808

affresh®* Stainless Steel Cleaner

In U.S.A., order Part Number W10355016

In Canada, order Part Number W10355016B

affresh®* Stainless Steel Wipes

In U.S.A., order Part Number W10355049

In Canada, order Part Number W10355049B

affresh®* Kitchen & Appliance Cleaner

In U.S.A., order Part Number W10355010

In Canada, order Part Number W10355010B

*®affresh is a registered trademark of Whirlpool, U.S.A.

Problem Solver

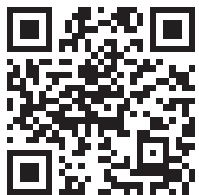

Scan the code at left with your mobile device, or visit <https://jennair.custhelp.com> for recommendations that may help you avoid a service call.

Ice Maker Operation

⚠ **WARNING**

Electrical Shock Hazard

Plug into a grounded 3 prong outlet.

Do not remove ground prong.

Do not use an adapter.

Do not use an extension cord.

Failure to follow these instructions can result in death, fire, or electrical shock.

PROBLEM	RECOMMENDED SOLUTIONS
Ice Maker Will Not Operate	<p>Check that it is plugged into a grounded 3 prong outlet.</p> <p>Check that the control is turned on.</p> <p>Replace the fuse or reset the circuit breaker.</p> <p>NOTE: If problems continue, contact an electrician.</p> <p>Room temperature must be above 55°F (13°C). Otherwise, bin thermostat may sense cold room temperature and shut off even though the bin is not full of ice. The ice maker may not restart once it does shut off.</p> <p>If there was a large amount of water added to the ice maker, wait a few minutes for the drain pump to clear. If there is still water in the bin, check to see whether the drain hose is kinked.</p> <p>For models with drain pumps, check that the drain hose is not damaged, or kinked or pinched between cabinet and ice maker. Use only Whirlpool approved drain pump kit, Part Number 1901A.</p>
Ice Maker Seems Noisy	<p>Water overflowing the reservoir is normal. This overflow helps to purge minerals that were removed from the water during the ice making process.</p> <p>If there is a “whooshing” sound, check the following things:</p> <ul style="list-style-type: none"> ■ Make sure that the water supply is hooked up and turned on. ■ Make sure that the drain cap is tight and the water drain pan pump is securely attached to the water pan. <p>If there is ice between the evaporator plate and the cutting grid, check that the ice maker is level. If the ice maker is level, and the problem persists, run a cleaning cycle.</p> <p>If the ice maker is connected to a water supply pressure in excess of 60 psi, you may hear a loud sound during water filling associated with the flow of water through the inlet valve. Call a licensed, qualified plumber to determine the best method to reduce the supply water pressure (50 psi is recommended).</p>

Ice Production

⚠ WARNING

<p>Electrical Shock Hazard</p> <p>Disconnect power before servicing.</p> <p>Replace all parts and panels before operating.</p> <p>Failure to do so can result in death or electrical shock.</p>

PROBLEM	RECOMMENDED SOLUTIONS
Ice Maker Runs But Produces No Ice	<p>Check that the control is turned on.</p> <p>Check that the water supply is properly connected and turned on.</p> <p>If the drain cap is loose, water will empty from the water pan, and you will have either thin ice or no ice. Tighten the drain cap.</p> <p>Clean the drain tube.</p> <p>Check that there are no kinks in the drain line.</p>
Ice Maker Runs But Produces Very Little Ice	<p>If the accelerated ice production feature is turned on, this feature increases the ice production rate to provide you with more ice in the same amount of time.</p> <p>Room temperatures of more than 90°F (32°C) will normally reduce ice production.</p> <p>Dirt or lint may be blocking the airflow through the condenser.</p> <p>If there is white scale buildup in the ice maker's water or freezing system, you should clean the ice maker.</p> <p>If the drain cap is loose, water will empty from the water pan, and you will have either thin ice or no ice. Tighten the drain cap.</p> <p>Ensure that the cutter grid is securely in place and that its harness plug is connected.</p> <p>Check that water filter is properly installed.</p>

Ice Quality

PROBLEM	RECOMMENDED SOLUTIONS
Off Taste, Odor or Gray Color in the Ice	<p>If there is unusually high mineral content in the water supply, the water may need to be treated.</p> <p>If there is mineral scale buildup, clean your ice maker.</p> <p>Do not store any foods in the ice bin.</p> <p>Make sure that all packaging materials were removed at the time of installation.</p>
Thin, Soft or Clumps of Ice	<p>If there is unusually high mineral content in the water supply, the water may need to be treated.</p> <p>If there is mineral scale buildup, clean your ice maker.</p> <p>If there are clumps of ice in the bin and if ice is not used regularly, it will melt and form clumps. Break the clumps with the ice scoop provided.</p>

Plumbing Problems

⚠ WARNING

Excessive Weight Hazard

Use two or more people to move and install ice maker.
Failure to do so can result in back or other injury.

PROBLEM	RECOMMENDED SOLUTIONS
Water Not Entering Drain Properly	If the drain hose is not aligned over the drain, move the ice maker to align the drain. NOTE: Service technicians cannot repair plumbing problems outside of the ice maker. Call a licensed, qualified plumber.

Performance Data Sheet

Ice Maker Water Filtration System Model P6GEG2KL, P6KG2KL, P6WG2KL Capacity 2000 Gallons (7571 Liters)



System tested and certified by NSF International against NSF/ANSI Standard 42 for the reduction of Chlorine Taste and Odor.

This system has been tested according to NSF/ANSI Standards 42 for the reduction of the substances listed below. The concentration of the indicated substances in water entering the system was reduced to a concentration less than or equal to the permissible limit for water leaving the system, as specified in NSF/ANSI Standards 42.

Substance Reduction Aesthetic Effects	NSF Reduction Requirements	Average Influent	Influent Challenge Concentration	Maximum Effluent	Average Effluent	Minimum % Reduction	Average % Reduction
Chlorine Taste/Odor	50% reduction	1.9727 mg/L	2.0 mg/L ± 10%	0.71 mg/L	0.7788 mg/L	70.2	72.81

Test Parameters: pH = 7.5 ± 0.5 unless otherwise noted. Flow = 0.50 gpm (1.89 Lpm). Pressure = 60 psig (413.7 kPa). Temp. = 68°F to 71.6°F (20°C to 22°C). Rated service capacity = 2000 gallons (7571 liters).

- It is essential that operational, maintenance, and filter replacement requirements be carried out for the product to perform as advertised.
- Use replacement filter P6RFWG2K, P6RFEG2K, P6RFKG2K, Part Number ICE2.
Style 1 – When the water filter status display changes from “GOOD” to “ORDER,” order a new filter. When the filter indicator reads “REPLACE,” it is recommended that you replace the filter.
Style 2 – Press FILTER to check the status of your water filter. If the filter indicator light is yellow and the words “ORDER FILTER” appear on the display screen, order a new filter. If the filter indicator light is red, it is recommended that you replace the filter.
- These contaminants are not necessarily in your water supply. While testing was performed under standard laboratory conditions, actual performance may vary.
- The product is for cold water use only.
- Do not use with water that is microbiologically unsafe or of unknown quality without adequate disinfection before or after the system.
- Refer to the “Warranty” section for the Manufacturer’s name, address and telephone number.

- Refer to the “Warranty” section for the Manufacturer’s limited warranty.

Application Guidelines/Water Supply Parameters

Water Supply	City or Well
Water Pressure	30 - 120 psi (207 - 827 kPa)
Water Temperature	33° - 100°F (0.6° - 37.8°C)
Service Flow Rate	0.50 gpm (1.89 Lpm) @ 60 psi

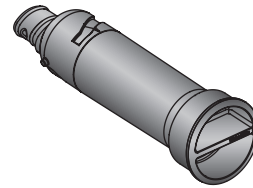

® NSF is a registered trademark of NSF International.

Warranty

JENN-AIR™ ICE MAKER WARRANTY

THREE YEAR LIMITED WARRANTY (PARTS AND LABOR)

For three years from the date of purchase, when this major appliance is installed, operated and maintained according to instructions attached to or furnished with the product, Jenn-Air brand of Whirlpool Corporation or Whirlpool Canada LP (hereafter "Jenn-Air") will pay for factory specified replacement parts and repair labor to correct defects in materials or workmanship that existed when this major appliance was purchased.

**FOURTH THROUGH FIFTH YEAR LIMITED WARRANTY
(SEALED REFRIGERATION SYSTEM PARTS ONLY - LABOR NOT INCLUDED)**

In the fourth through the fifth years from the date of original purchase, when this major appliance is installed, operated and maintained according to instructions attached to or furnished with the product, Jenn-Air will pay for factory specified replacement parts for the following components to correct non-cosmetic defects in materials or workmanship in the sealed refrigeration system that existed when this major appliance was purchased: compressor, evaporator, condenser, dryer/strainer, and connecting tubing. This limited 5-year warranty is only for the sealed refrigeration system replacement parts as identified and does not include labor.

YOUR SOLE AND EXCLUSIVE REMEDY UNDER THE LIMITED WARRANTY SHALL BE PRODUCT REPAIR AS PROVIDED HEREIN. Service must be provided by a Jenn-Air designated service company. This limited warranty is valid only in the United States or Canada and applies only when the major appliance is used in the country in which it was purchased. This limited warranty is effective from the date of the original consumer purchase. Proof of original purchase date is required to obtain service under this limited warranty.

ITEMS EXCLUDED FROM WARRANTY

This limited warranty does not cover:

1. Replacement parts or repair labor if this major appliance is used for other than normal, single-family household use or when it is used in a manner that is inconsistent to published user or operator instructions and/or installation instructions.
2. Service calls to correct the installation of your major appliance, to instruct you on how to use your major appliance, to replace or repair house fuses, or to correct house wiring or plumbing.
3. Service calls to repair or replace appliance light bulbs, air filters or water filters. Consumable parts are excluded from warranty coverage.
4. Damage resulting from accident, alteration, misuse, abuse, fire, flood, acts of God, improper installation, installation not in accordance with electrical or plumbing codes, or use of products not approved by Jenn-Air.
5. Cosmetic damage, including scratches, dents, chips or other damage to the finish of your major appliance, unless such damage results from defects in materials or workmanship and is reported to Jenn-Air within 30 days from the date of purchase.
6. Any food or medicine loss due to refrigerator or freezer product failures.
7. Pickup and delivery. This major appliance is intended to be repaired in your home.
8. Repairs to parts or systems resulting from unauthorized modifications made to the appliance.
9. Expenses for travel and transportation for product service if your major appliance is located in a remote area where service by an authorized Jenn-Air servicer is not available.
10. The removal and reinstallation of your major appliance if it is installed in an inaccessible location or is not installed in accordance with Jenn-Air's published installation instructions.
11. Replacement parts or repair labor on major appliances with original model/serial numbers that have been removed, altered or cannot be easily determined.
12. Discoloration, rust or oxidation of stainless steel surfaces.

The cost of repair or replacement under these excluded circumstances shall be borne by the customer.

DISCLAIMER OF IMPLIED WARRANTIES

IMPLIED WARRANTIES, INCLUDING ANY IMPLIED WARRANTY OF MERCHANTABILITY OR IMPLIED WARRANTY OF FITNESS FOR A PARTICULAR PURPOSE, ARE LIMITED TO ONE YEAR OR THE SHORTEST PERIOD ALLOWED BY LAW. Some states and provinces do not allow limitations on the duration of implied warranties of merchantability or fitness, so this limitation may not apply to you. This warranty gives you specific legal rights, and you also may have other rights that vary from state to state or province to province.

DISCLAIMER OF REPRESENTATIONS OUTSIDE OF WARRANTY

Jenn-Air makes no representations about the quality, durability, or need for service or repair of this major appliance other than the representations contained in this Warranty. If you want a longer or more comprehensive warranty than the limited warranty that comes with this major appliance, you should ask Jenn-Air or your retailer about buying an extended warranty.

LIMITATION OF REMEDIES; EXCLUSION OF INCIDENTAL AND CONSEQUENTIAL DAMAGES

YOUR SOLE AND EXCLUSIVE REMEDY UNDER THIS LIMITED WARRANTY SHALL BE PRODUCT REPAIR AS PROVIDED HEREIN. JENN-AIR SHALL NOT BE LIABLE FOR INCIDENTAL OR CONSEQUENTIAL DAMAGES. Some states and provinces do not allow the exclusion or limitation of incidental or consequential damages, so these limitations and exclusions may not apply to you. This warranty gives you specific legal rights, and you also may have other rights that vary from state to state or province to province.

If outside the 50 United States and Canada, contact your authorized Jenn-Air dealer to determine if another warranty applies.

1/11

For additional product information, in the U.S.A., visit www.jennair.com. In Canada, visit www.jennair.ca.

If you do not have access to the Internet and you need assistance using your product or you would like to schedule service, you may contact Jenn-Air at the number below.

Have your complete model number ready. You can find your model number and serial number on the label, located on the inside wall of the ice maker.

For assistance or service, call 1-800-JENN-AIR (536-6247). If you need further assistance, you can write to Jenn-Air with any questions or concerns at the address below:

In the U.S.A.:

Jenn-Air Brand Home Appliances
Customer eXperience Center
553 Benson Road
Benton Harbor, MI 49022-2692

In Canada:

Jenn-Air Brand Home Appliances
Customer eXperience Centre
200 – 6750 Century Ave.
Mississauga, Ontario L5N 0B7

Please include a daytime phone number in your correspondence.

Please keep all provided instructions and your model number information for future reference.



User Guide

Ice Maker



LEARN MORE

In an effort to conserve natural resources, this ice maker includes a condensed User Guide. A complete Use and Care Guide can be downloaded at www.kitchenaid.com/manuals. The model number is located on the inside of the ice maker.

In the U.S.A., register your ice maker at www.kitchenaid.com.

In Canada, register your ice maker at www.kitchenaid.ca.

Para una version de estas instrucciones en español, visite www.kitchenaid.com.

Your safety and the safety of others are very important.

We have provided many important safety messages in this manual and on your appliance. Always read and obey all safety messages.



This is the safety alert symbol.

This symbol alerts you to potential hazards that can kill or hurt you and others.

All safety messages will follow the safety alert symbol and either the word "DANGER" or "WARNING."

These words mean:

DANGER

You can be killed or seriously injured if you don't immediately follow instructions.

WARNING

You can be killed or seriously injured if you don't follow instructions.

All safety messages will tell you what the potential hazard is, tell you how to reduce the chance of injury, and tell you what can happen if the instructions are not followed.

IMPORTANT SAFETY INSTRUCTIONS

WARNING: To reduce the risk of fire, electric shock, or injury when using your ice maker, follow these basic precautions:

- Plug into a grounded 3 prong outlet.
- Do not remove ground prong.
- Do not use an adapter.
- Do not use an extension cord.
- Disconnect power before cleaning.
- Disconnect power before servicing.
- Replace all parts and panels before operating.
- Use two or more people to move and install ice maker.

SAVE THESE INSTRUCTIONS

State of California Proposition 65 Warnings:

WARNING: This product contains one or more chemicals known to the State of California to cause cancer.

WARNING: This product contains one or more chemicals known to the State of California to cause birth defects or other reproductive harm.

OPERATING YOUR ICE MAKER

How Your Ice Maker Works

When you first start your ice maker, the water pan will fill and the system will rinse itself before starting to make ice. The rinsing process takes about 5 minutes.

Under normal operating conditions, the ice maker will cycle at preset temperatures. The ice level sensor located in the ice storage bin will monitor the ice levels.

IMPORTANT: If the water supply to the ice maker is turned off, be sure to set the ice maker control to OFF.

The Ice Making Process

1. Water is constantly circulated over a freezing plate. As the water freezes into ice, the minerals in the water are rejected. This produces a sheet of ice with a low mineral content.

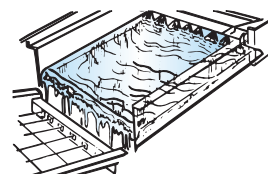

- When the desired thickness is reached, the ice sheet is released and slides onto a cutter grid. The grid divides the sheet into individual cubes.
- The water containing the rejected minerals is drained after each freezing cycle.

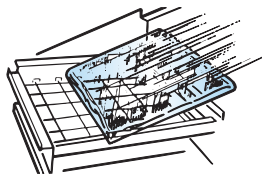

- Fresh water enters the machine for the next ice making cycle.
- Cubes fall into the storage bin. When the bin is full, the ice maker shuts off automatically and restarts when more ice is needed. The ice bin is not refrigerated, and some melting will occur. The amount of melting varies with room temperature.

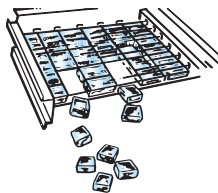

NOTE: As the room and water temperatures vary, so will the amount of ice produced and stored. This means that higher operating temperatures result in reduced ice production.

Using the Controls

- To start ice production, press ON/OFF.
- To stop ice maker operation, press ON/OFF.

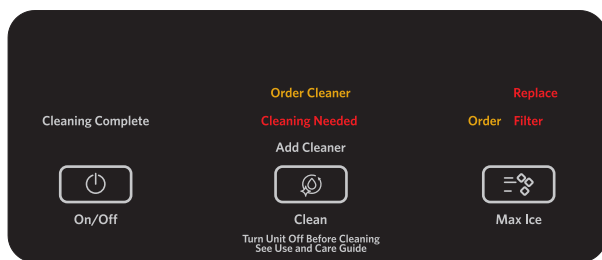

NOTES:

- Pressing the On/Off button does not shut off power to the ice maker.
- Allow 24 hours to produce the first batch of ice. Discard the first 2 batches produced.

Max Ice Mode

Select the Max Ice feature when you have an upcoming need for a large amount of ice and the ice bin is low or empty. Max Ice mode will produce a greater quantity of ice in a 24-hour period.

- Press MAX ICE while the ice maker is on. The indicator light will illuminate.
- Press MAX ICE again to turn off the Max Ice feature. The indicator light will turn off.
- The Max Ice mode will be on when you first turn on the product. It will turn off after 24 hours. To turn Max Ice back on, press MAX ICE.

Clean

It is recommended that you clean the ice maker when the "Cleaning Needed" light is illuminated or 9 months has elapsed or ice production decreases significantly. To clean your ice maker, see "Ice Maker System" in the "Cleaning" section.

Door Ajar Alarm

The Door Ajar Alarm feature sounds an alarm when the ice maker door is open for 5 minutes. The alarm will repeat every 2 minutes. Close the door to turn off. The feature then resets and will reactivate when the door is left open again for 5 minutes.

Water Filtration System

Do not use with water that is microbiologically unsafe or of unknown quality without adequate disinfection before or after the system. Systems certified for cyst reduction may be used on disinfected waters that may contain filterable cysts.

Install the Water Filter

- Locate the accessory packet in the ice maker and remove the water filter.
- Take the water filter out of its packaging and remove the cover from the O-rings. Be sure the O-rings are still in place after the cover is removed.

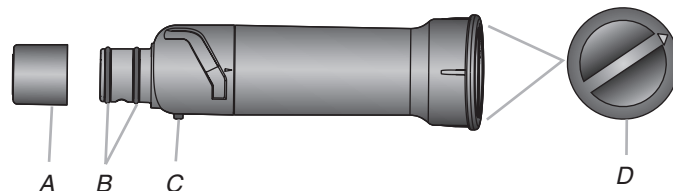

A. Cover
B. O-rings
C. Alignment pin
D. Alignment arrow

- The water filter compartment is located in the right-hand side of the ice maker controls. For 15" (38.1 cm) models, push in on the door to release the latch, and then lower the door.

15" (38.1 cm) models

18" (45.7 cm) models

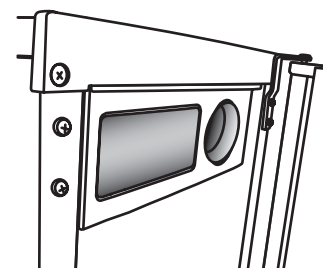
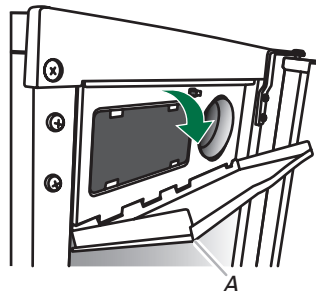

A. Door

- Using the arrow pointing to the alignment pin on the side of the filter and the arrow inside the control housing, align the alignment pin with the cutout notch and insert the filter into the housing.

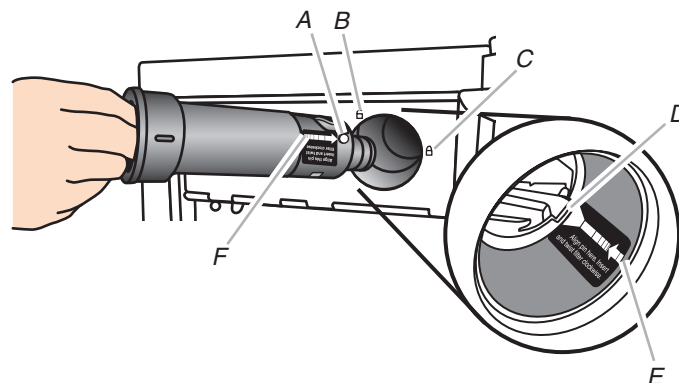

A. Alignment pin
B. Unlocked symbol
C. Locked symbol
D. Cutout notch inside control housing
E. Arrow pointing to cutout notch
F. Arrow pointing to alignment pin

CONTROLS AND OPERATING INSTRUCTIONS

- Turn the filter clockwise until it locks into the housing. Ensure that the alignment arrow on the filter head aligns with the locked symbol on the control box housing.

NOTE: If the filter is not correctly locked into the housing, the ice maker will not produce ice.

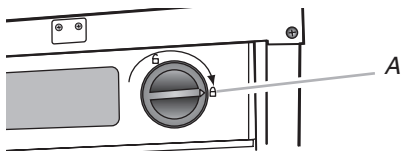

A. Alignment arrow aligned with locked symbol

- For 15" (38.1 cm) models, push the control box door closed until the latch snaps closed.

The Water Filter Status Light

The water filter status lights will help you know when to change your water filter.

- The "Order Filter" status light will be illuminated when it is time to order a replacement filter.
- The "Replace Filter" status light will be illuminated when it is time to replace the filter.
- Replacing the disposable water filter with a new filter will automatically reset the filter status tracking feature. See "Using the Controls."

NOTES:

- "Replace Filter" will remain illuminated if a filter is not installed.
- The "Filter" status light will flash if the filter is not correctly installed or there is an obstruction in the water line.

Replace the Water Filter

To purchase a replacement water filter, see "Accessories."

Replace the disposable water filter when indicated on the water filter status display or at least every 9 months. If the ice making rate decreases before the Replace Filter light illuminates, then replace the filter.

- Locate the water filter compartment in the right-hand side of the control housing. See Step 3 in the "Install Water Filter" section.
- Turn the water filter counterclockwise (to the left), and pull it straight out of the compartment.

NOTE: There may be some water in the filter. Some spillage may occur.

- Install the replacement water filter by following steps 2 through 5 in the "Install the Water Filter" section.

Normal Sounds

Your new ice maker may make sounds that are not familiar to you. Because the sounds are new to you, you might be concerned about them. Most of the new sounds are normal. Hard surfaces such as floors, walls and cabinets can make the sounds seem louder than they actually are. The following describes the kinds of sounds that might be new to you and what may be making them.

- You will hear a buzzing sound when the water valve opens to fill the water pan for each cycle.
- Rattling noises may come from the flow of the refrigerant or the water line. Items stored on top of the ice maker can also make noises.
- The high-efficiency compressor may make a pulsating or high pitched sound.
- Water running over the evaporator plate may make a splashing sound.
- Water running from the evaporator plate to the water pan may make a splashing sound.
- As each cycle ends, you may hear a gurgling sound due to the refrigerant flowing in your ice maker.
- You may hear air being forced over the condenser by the condenser fan.
- During the harvest cycle, you may hear a "thud" when the ice sheet slides from the evaporator onto the cutter grid.
- When you first start the ice maker, you may hear water running continuously. The ice maker is programmed to run a rinse cycle before it begins to make ice.
- If the ice maker is connected to a water supply pressure in excess of 60 psi, you may hear a loud sound during water filling associated with the flow of water through the inlet valve. Call a licensed, qualified plumber to determine the best method to reduce the supply water pressure (50 psi is recommended).

CARING FOR YOUR ICE MAKER

Cleaning

The ice making system and the air cooled condenser need to be cleaned regularly for the ice maker to operate at peak efficiency and to avoid premature failure of system components. See the "Ice Maker System" and the "Condenser" sections.

Exterior Surfaces

Wash the exterior enamel surfaces and gaskets with warm water and mild soap or detergent. Wipe and dry. Regular use of a good household appliance cleaner and wax will help maintain the finish. Do not use abrasive cleaners on enamel surfaces as they may scratch the finish.

For products with a stainless steel exterior, use a clean sponge or soft cloth and a mild detergent in warm water. Do not use abrasive or harsh cleaners. Do not use chlorine bleach on the stainless steel surfaces.

Ice Maker System

Minerals that are removed from water during the freezing cycle will eventually form a hard scaly deposit in the water system. Cleaning the system regularly helps remove the mineral scale buildup. How often you need to clean the system depends upon how hard your water is. With hard water of 15 to 20 grains/gal. (4 to 5 grains/liter), you may need to clean the system as often as every 9 months.

NOTE: Use one 16 oz (473 mL) bottle of approved ice maker cleaner. To order, see "Accessories."

- Press the ON/OFF button.
- Wait 5 to 10 minutes for the ice to fall into the storage bin. Remove all ice from the storage bin.
- Unscrew the drain cap from the bottom of the water pan located inside the storage bin as shown. Allow the water to drain completely.
- Replace the drain cap securely on the water pan. If the drain cap is loose, water will empty from the water pan and you will have either thin ice or no ice.
- Read and follow all handling information on the cleaner bottle before completing the steps below. Use one 16 oz (473 mL) bottle of approved ice maker cleaner.

- Pour one bottle of solution into the water pan. Fill the bottle twice with tap water and pour it into the water pan.

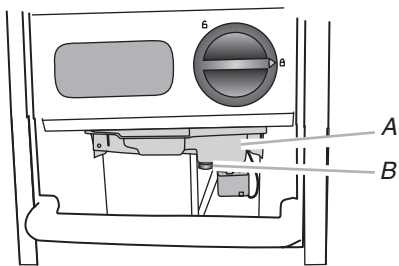

A. Water pan
B. Drain cap

- Press the CLEAN button. See “Using the Controls.” The light will blink, indicating that the cleaning cycle is in process. When the “Cleaning Complete” light is illuminated (approximately 70 minutes), the cleaning cycle is complete. During the cleaning cycle, the system will both clean and rinse itself.
- After the cleaning cycle is complete, remove the drain cap from the water pan. Look for any cleaning solution left in the water pan. If cleaning solution drains from the water pan, you should run the clean cycle again. Be sure to refill the water pan with cleaner before starting the clean cycle again. Be sure to replace the drain cap securely on the water pan. If the drain cap is loose, water will empty from the water pan and you will have either thin ice or no ice.

NOTE: Severe scale buildup may require repeated cleaning with a fresh quantity of cleaning solution.

- Press the ON/OFF button to resume ice production.

Condenser

A Dirty or Clogged Condenser

- Obstructs proper airflow.
- Reduces ice making capacity.
- Causes higher than recommended operating temperatures which may lead to component failure.

⚠ WARNING



Electrical Shock Hazard

Disconnect power before cleaning.

Replace all parts and panels before operating.

Failure to do so can result in death or electrical shock.

- Unplug ice maker or disconnect power.
- Remove the 2 screws in the lower access panel and the 2 screws from the base grille area of the front panel support.
- Pull the bottom forward and then pull down to remove the lower access panel.

15" (38.1 cm) models

18" (45.7 cm) models

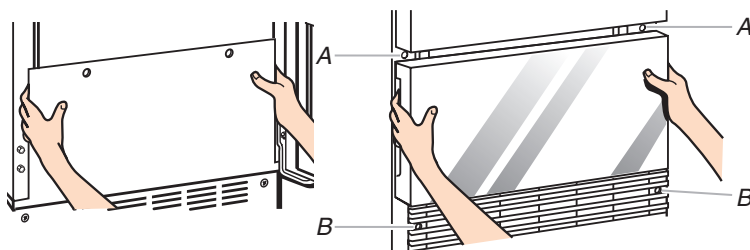

A. Lower access panel screws
B. Base grille screws

- Remove dirt and lint from the condenser fins and the unit compartment with a brush attachment on a vacuum cleaner.

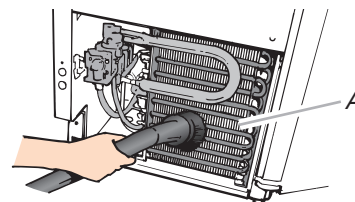

A. Condenser fins

- Replace the lower access panel using the 4 screws.
- Plug in ice maker or reconnect power.

ACCESSORIES

To order accessories, in the U.S.A., visit our website www.kitchenaid.com/accessories or call 1-800-901-2042.

In Canada, visit our website www.whirlpoolparts.ca or call 1-800-807-6777.

Water Filter

Order Part Number F2WC9I1 or ICE2

Cleaner

Order Part Number 4396808

affresh®* Stainless Steel Cleaner

In U.S.A., order Part Number W10355016

In Canada, order Part Number W10355016B

affresh®* Stainless Steel Wipes

In U.S.A., order Part Number W10355049

In Canada, order Part Number W10355049B

affresh®* Kitchen & Appliance Cleaner

In U.S.A., order Part Number W10355010

In Canada, order Part Number W10355010B

*®affresh is a registered trademark of Whirlpool, U.S.A.

PROBLEM SOLVER



Scan the code at left with your mobile device, or visit <https://kitchenaid.custhelp.com> for recommendations that may help you avoid a service call.

Ice Maker Operation

⚠ WARNING

Electrical Shock Hazard

Plug into a grounded 3 prong outlet.

Do not remove ground prong.

Do not use an adapter.

Do not use an extension cord.

Failure to follow these instructions can result in death, fire, or electrical shock.

PROBLEM	RECOMMENDED SOLUTIONS
Ice Maker Will Not Operate	<p>Check that it is plugged into a grounded 3 prong outlet.</p> <p>Check that the control is turned on.</p> <p>Replace the fuse or reset the circuit breaker.</p> <p>NOTE: If problems continue, contact an electrician.</p> <p>Room temperature must be above 55°F (13°C). Otherwise, bin thermostat may sense cold room temperature and shut off even though the bin is not full of ice. The ice maker may not restart once it does shut off.</p> <p>If there was a large amount of water added to the ice maker, wait a few minutes for the drain pump to clear. If there is still water in the bin, check to see whether the drain hose is kinked.</p> <p>For models with drain pumps, check that the drain hose is not damaged, or kinked or pinched between cabinet and ice maker. Use only Whirlpool approved drain pump kit, Part Number 1901A.</p>
Ice Maker Seems Noisy	<p>Water overflowing the reservoir is normal. This overflow helps to purge minerals that were removed from the water during the ice making process.</p> <p>If there is a “whooshing” sound, check the following things:</p> <ul style="list-style-type: none"> ■ Make sure that the water supply is hooked up and turned on. ■ Make sure that the drain cap is tight and the water drain pan pump is securely attached to the water pan. <p>If there is ice between the evaporator plate and the cutting grid, check that the ice maker is level. If the ice maker is level, and the problem persists, run a cleaning cycle.</p> <p>If the ice maker is connected to a water supply pressure in excess of 60 psi, you may hear a loud sound during water filling associated with the flow of water through the inlet valve. Call a licensed, qualified plumber to determine the best method to reduce the supply water pressure (50 psi is recommended).</p>

Ice Production

⚠ WARNING

<p>Electrical Shock Hazard</p> <p>Disconnect power before servicing.</p> <p>Replace all parts and panels before operating.</p> <p>Failure to do so can result in death or electrical shock.</p>

PROBLEM	RECOMMENDED SOLUTIONS
Ice Maker Runs But Produces No Ice	<p>Check that the control is turned on.</p> <p>Check that the water supply is properly connected and turned on.</p> <p>If the drain cap is loose, water will empty from the water pan, and you will have either thin ice or no ice. Tighten the drain cap.</p> <p>Clean the drain tube.</p> <p>Check that there are no kinks in the drain line.</p>
Ice Maker Runs But Produces Very Little Ice	<p>If the accelerated ice production feature is turned on, this feature increases the ice production rate to provide you with more ice in the same amount of time.</p> <p>Room temperatures of more than 90°F (32°C) will normally reduce ice production.</p> <p>Dirt or lint may be blocking the airflow through the condenser.</p> <p>If there is white scale buildup in the ice maker's water or freezing system, you should clean the ice maker.</p> <p>If the drain cap is loose, water will empty from the water pan, and you will have either thin ice or no ice. Tighten the drain cap.</p> <p>Ensure that the cutter grid is securely in place and that its harness plug is connected.</p> <p>Check that water filter is properly installed.</p>

Ice Quality

PROBLEM	RECOMMENDED SOLUTIONS
Off Taste, Odor or Gray Color in the Ice	<p>If there is unusually high mineral content in the water supply, the water may need to be treated.</p> <p>If there is mineral scale buildup, clean your ice maker.</p> <p>Do not store any foods in the ice bin.</p> <p>Make sure that all packaging materials were removed at the time of installation.</p>
Thin, Soft or Clumps of Ice	<p>If there is unusually high mineral content in the water supply, the water may need to be treated.</p> <p>If there is mineral scale buildup, clean your ice maker.</p> <p>If there are clumps of ice in the bin and if ice is not used regularly, it will melt and form clumps. Break the clumps with the ice scoop provided.</p>

⚠ WARNING

Excessive Weight Hazard

Use two or more people to move and install ice maker.
Failure to do so can result in back or other injury.

PROBLEM

RECOMMENDED SOLUTIONS

Water Not Entering Drain Properly

If the drain hose is not aligned over the drain, move the ice maker to align the drain.

NOTE: Service technicians cannot repair plumbing problems outside of the ice maker. Call a licensed, qualified plumber.

PERFORMANCE DATA SHEET

Ice Maker Water Filtration System Model P6GEG2KL, P6KG2KL, P6WG2KL Capacity 2000 Gallons (7571 Liters)



System tested and certified by NSF International against NSF/ANSI Standard 42 for the reduction of Chlorine Taste and Odor.

This system has been tested according to NSF/ANSI Standards 42 for the reduction of the substances listed below. The concentration of the indicated substances in water entering the system was reduced to a concentration less than or equal to the permissible limit for water leaving the system, as specified in NSF/ANSI Standards 42.

Substance Reduction Aesthetic Effects	NSF Reduction Requirements	Average Influent	Influent Challenge Concentration	Maximum Effluent	Average Effluent	Minimum % Reduction	Average % Reduction
Chlorine Taste/Odor	50% reduction	1.9727 mg/L	2.0 mg/L ± 10%	0.71 mg/L	0.7788 mg/L	70.2	72.81

Test Parameters: pH = 7.5 ± 0.5 unless otherwise noted. Flow = 0.50 gpm (1.89 Lpm). Pressure = 60 psig (413.7 kPa). Temp. = 68°F to 71.6°F (20°C to 22°C). Rated service capacity = 2000 gallons (7571 liters).

- It is essential that operational, maintenance, and filter replacement requirements be carried out for the product to perform as advertised.

- Use replacement filter P6RFWG2K, P6RFEG2K, P6RFKG2K, Part Number ICE2.

Style 1 – When the water filter status display changes from “GOOD” to “ORDER,” order a new filter. When the filter indicator reads “REPLACE,” it is recommended that you replace the filter.

Style 2 – Press FILTER to check the status of your water filter. If the filter indicator light is yellow and the words “ORDER FILTER” appear on the display screen, order a new filter. If the filter indicator light is red, it is recommended that you replace the filter.

- These contaminants are not necessarily in your water supply. While testing was performed under standard laboratory conditions, actual performance may vary.
- The product is for cold water use only.
- Do not use with water that is microbiologically unsafe or of unknown quality without adequate disinfection before or after the system.
- Refer to the “Warranty” section for the Manufacturer’s name, address and telephone number.

- Refer to the “Warranty” section for the Manufacturer’s limited warranty.

Application Guidelines/Water Supply Parameters

Water Supply	City or Well
Water Pressure	30 - 120 psi (207 - 827 kPa)
Water Temperature	33° - 100°F (0.6° - 37.8°C)
Service Flow Rate	0.50 gpm (1.89 Lpm) @ 60 psi

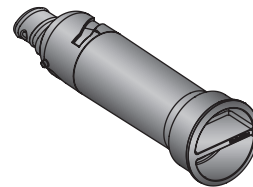

WARRANTY

KITCHENAID® ICE MAKER WARRANTY

THREE YEAR LIMITED WARRANTY (PARTS AND LABOR)

For three years from the date of purchase, when this major appliance is installed, operated and maintained according to instructions attached to or furnished with the product, KitchenAid brand of Whirlpool Corporation or Whirlpool Canada LP (hereafter "KitchenAid") will pay for factory specified replacement parts and repair labor to correct defects in materials or workmanship that existed when this major appliance was purchased.

**FOURTH THROUGH FIFTH YEAR LIMITED WARRANTY
(SEALED REFRIGERATION SYSTEM PARTS ONLY - LABOR NOT INCLUDED)**

In the fourth through the fifth year from the date of original purchase, when this major appliance is installed, operated and maintained according to instructions attached to or furnished with the product, KitchenAid will pay for factory specified replacement parts for the following components to correct non-cosmetic defects in materials or workmanship in the sealed refrigeration system that existed when this major appliance was purchased: compressor, evaporator, condenser, dryer/strainer, and connecting tubing. This limited 5-year warranty is only for the sealed refrigeration system replacement parts as identified and does not include labor.

YOUR SOLE AND EXCLUSIVE REMEDY UNDER THIS LIMITED WARRANTY SHALL BE PRODUCT REPAIR AS PROVIDED HEREIN. Service must be provided by a KitchenAid designated service company. This limited warranty is valid only in the United States or Canada and applies only when the major appliance is used in the country in which it was purchased. This limited warranty is effective from the date of original consumer purchase. Proof of original purchase date is required to obtain service under this limited warranty.

ITEMS EXCLUDED FROM WARRANTY

This limited warranty does not cover:

1. Replacement parts or repair labor if this major appliance is used for other than normal, single-family household use or when it is used in a manner that is inconsistent to published user or operator instructions and/or installation instructions.
2. Service calls to correct the installation of your major appliance, to instruct you on how to use your major appliance, to replace or repair house fuses, or to correct house wiring or plumbing.
3. Service calls to repair or replace appliance light bulbs, air filters or water filters. Consumable parts are excluded from warranty coverage.
4. Damage resulting from accident, alteration, misuse, abuse, fire, flood, acts of God, improper installation, installation not in accordance with electrical or plumbing codes, or use of products not approved by KitchenAid.
5. Cosmetic damage, including scratches, dents, chips or other damage to the finish of your major appliance, unless such damage results from defects in materials or workmanship and is reported to KitchenAid within 30 days from the date of purchase.
6. Any food or medicine loss due to refrigerator or freezer product failures.
7. Pickup and delivery. This major appliance is intended to be repaired in your home.
8. Repairs to parts or systems resulting from unauthorized modifications made to the appliance.
9. Expenses for travel and transportation for product service if your major appliance is located in a remote area where service by an authorized KitchenAid servicer is not available.
10. The removal and reinstallation of your major appliance if it is installed in an inaccessible location or is not installed in accordance with KitchenAid's published installation instructions.
11. Replacement parts or repair labor on major appliances with original model/serial numbers that have been removed, altered or cannot be easily determined.
12. Discoloration, rust or oxidation of stainless steel surfaces.

The cost of repair or replacement under these excluded circumstances shall be borne by the customer.

DISCLAIMER OF IMPLIED WARRANTIES

IMPLIED WARRANTIES, INCLUDING ANY IMPLIED WARRANTY OF MERCHANTABILITY OR IMPLIED WARRANTY OF FITNESS FOR A PARTICULAR PURPOSE, ARE LIMITED TO ONE YEAR OR THE SHORTEST PERIOD ALLOWED BY LAW. Some states and provinces do not allow limitations on the duration of implied warranties of merchantability or fitness, so this limitation may not apply to you. This warranty gives you specific legal rights, and you also may have other rights that vary from state to state or province to province.

DISCLAIMER OF REPRESENTATIONS OUTSIDE OF WARRANTY

KitchenAid makes no representations about the quality, durability, or need for service or repair of this major appliance other than the representations contained in this Warranty. If you want a longer or more comprehensive warranty than the limited warranty that comes with this major appliance, you should ask KitchenAid or your retailer about buying an extended warranty.

LIMITATION OF REMEDIES; EXCLUSION OF INCIDENTAL AND CONSEQUENTIAL DAMAGES

YOUR SOLE AND EXCLUSIVE REMEDY UNDER THIS LIMITED WARRANTY SHALL BE PRODUCT REPAIR AS PROVIDED HEREIN. KITCHENAID SHALL NOT BE LIABLE FOR INCIDENTAL OR CONSEQUENTIAL DAMAGES. Some states and provinces do not allow the exclusion or limitation of incidental or consequential damages, so these limitations and exclusions may not apply to you. This warranty gives you specific legal rights, and you also may have other rights that vary from state to state or province to province.

If outside the 50 United States and Canada, contact your authorized KitchenAid dealer to determine if another warranty applies.

2/11

For additional product information, in the U.S.A., visit www.kitchenaid.com.

In Canada, visit www.kitchenaid.ca.

If you do not have access to the Internet and you need assistance using your product or you would like to schedule service, you may contact KitchenAid at the number below.

Have your complete model number ready. You can find your model number and serial number on the label, located on the inside wall of the ice maker.

For assistance or service in the U.S.A., call 1-800-422-1230. In Canada, call 1-800-807-6777.

If you need further assistance, you can write to KitchenAid with any questions or concerns at the address below:

In the U.S.A.:

KitchenAid Brand Home Appliances
Customer eXperience Center
553 Benson Road
Benton Harbor, MI 49022-2692

In Canada:

KitchenAid Brand Home Appliances
Customer eXperience Centre
200 – 6750 Century Ave.
Mississauga, Ontario L5N 0B7

Please include a daytime phone number in your correspondence.

Please keep all provided instructions and your model number information for future reference.



User Guide

Ice Maker



LEARN MORE

In an effort to conserve natural resources, this ice maker includes a condensed User Guide. A complete User Guide can be downloaded at www.maytag.com/manuals.

The model number is located on the inside of the ice maker.

Register your ice maker at www.maytag.com

Para una version de estas instrucciones en español, visite www.maytag.com.

Your safety and the safety of others are very important.

We have provided many important safety messages in this manual and on your appliance. Always read and obey all safety messages.



This is the safety alert symbol.

This symbol alerts you to potential hazards that can kill or hurt you and others.

All safety messages will follow the safety alert symbol and either the word "DANGER" or "WARNING."

These words mean:

DANGER

You can be killed or seriously injured if you don't immediately follow instructions.

WARNING

You can be killed or seriously injured if you don't follow instructions.

All safety messages will tell you what the potential hazard is, tell you how to reduce the chance of injury, and tell you what can happen if the instructions are not followed.

IMPORTANT SAFETY INSTRUCTIONS

WARNING: To reduce the risk of fire, electric shock, or injury when using your ice maker, follow these basic precautions:

- Plug into a grounded 3 prong outlet.
- Do not remove ground prong.
- Do not use an adapter.
- Do not use an extension cord.
- Disconnect power before cleaning.
- Disconnect power before servicing.
- Replace all parts and panels before operating.
- Use two or more people to move and install ice maker.

SAVE THESE INSTRUCTIONS

State of California Proposition 65 Warnings:

WARNING: This product contains one or more chemicals known to the State of California to cause cancer.

WARNING: This product contains one or more chemicals known to the State of California to cause birth defects or other reproductive harm.

OPERATING YOUR ICE MAKER

How Your Ice Maker Works

When you first start your ice maker, the water pan will fill and the system will rinse itself before starting to make ice. The rinsing process takes about 5 minutes.

Under normal operating conditions, the ice maker will cycle at preset temperatures. The ice level sensor located in the ice storage bin will monitor the ice levels.

IMPORTANT: If the water supply to the ice maker is turned off, be sure to set the ice maker control to OFF.

The Ice Making Process

1. Water is constantly circulated over a freezing plate. As the water freezes into ice, the minerals in the water are rejected. This produces a sheet of ice with a low mineral content.

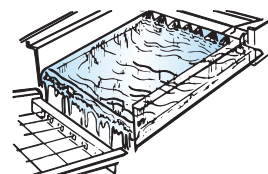

2. When the desired thickness is reached, the ice sheet is released and slides onto a cutter grid. The grid divides the sheet into individual cubes.

3. The water containing the rejected minerals is drained after each freezing cycle.

4. Fresh water enters the machine for the next ice making cycle.

5. Cubes fall into the storage bin. When the bin is full, the ice maker shuts off automatically and restarts when more ice is needed. The ice bin is not refrigerated, and some melting will occur. The amount of melting varies with room temperature.

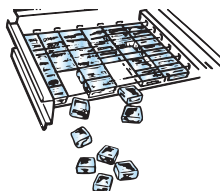
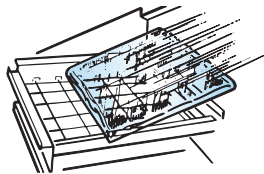

NOTE: As the room and water temperatures vary, so will the amount of ice produced and stored. This means that higher operating temperatures result in reduced ice production.

Using the Controls

- To start ice production, press ON/OFF.
- To stop ice maker operation, press ON/OFF.

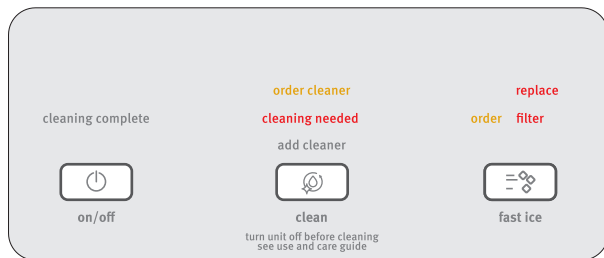

NOTES:

- Pressing the On/Off button does not shut off power to the ice maker.
- Allow 24 hours to produce the first batch of ice. Discard the first 2 batches produced.

Fast Ice Mode

Select the Fast Ice feature when you have an upcoming need for a large amount of ice and the ice bin is low or empty. Fast Ice mode will produce a greater quantity of ice in a 24-hour period.

- Press FAST ICE while the ice maker is on. The indicator light will illuminate.
- Press FAST ICE again to turn off the Max Ice feature. The indicator light will turn off.
- The Fast Ice mode will be on when you first turn on the product. It will turn off after 24 hours. To turn Fast Ice back on, press FAST ICE.

Clean

It is recommended that you clean the ice maker when the "Cleaning Needed" light is illuminated or 9 months has elapsed or ice production decreases significantly. To clean your ice maker, see "Ice Maker System" in the "Cleaning" section.

Door Ajar Alarm

The Door Ajar Alarm feature sounds an alarm when the ice maker door is open for 5 minutes. The alarm will repeat every 2 minutes. Close the door to turn off. The feature then resets and will reactivate when the door is left open again for 5 minutes.

Water Filtration System

Do not use with water that is microbiologically unsafe or of unknown quality without adequate disinfection before or after the system. Systems certified for cyst reduction may be used on disinfected waters that may contain filterable cysts.

Install the Water Filter

- Locate the accessory packet in the ice maker and remove the water filter.
- Take the water filter out of its packaging and remove the cover from the O-rings. Be sure the O-rings are still in place after the cover is removed.

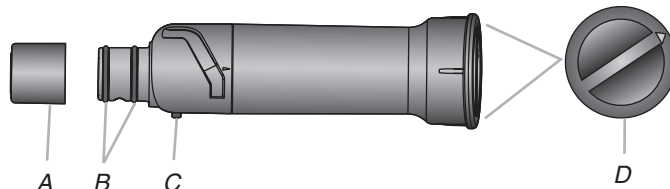

A. Cover
B. O-rings
C. Alignment pin
D. Alignment arrow

- The water filter compartment is located in the right-hand side of the ice maker controls.

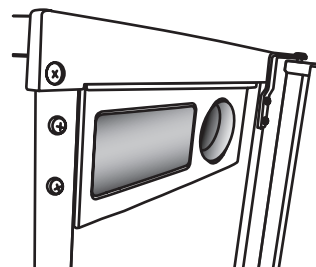

- Using the arrow pointing to the alignment pin on the side of the filter and the arrow inside the control housing, align the alignment pin with the cutout notch and insert the filter into the housing.

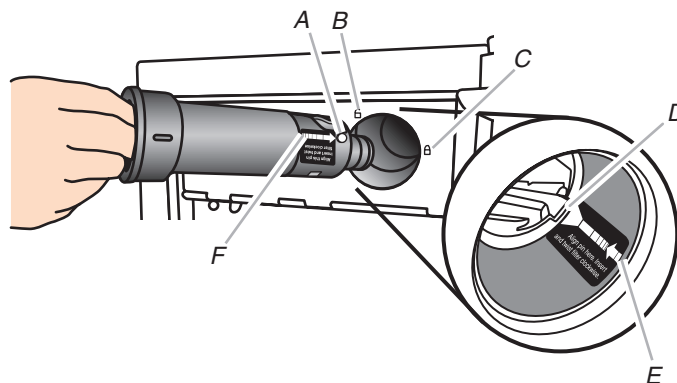

A. Alignment pin
B. Unlocked symbol
C. Locked symbol
D. Cutout notch inside control housing
E. Arrow pointing to cutout notch
F. Arrow pointing to alignment pin

- Turn the filter clockwise until it locks into the housing. Ensure that the alignment arrow on the filter head aligns with the locked symbol on the control box housing.

CONTROLS AND OPERATING INSTRUCTIONS

NOTE: If the filter is not correctly locked into the housing, the ice maker will not produce ice.

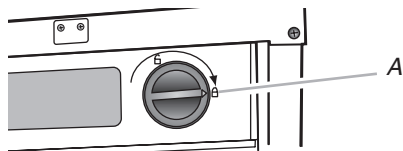

A. Alignment arrow aligned with locked symbol

The Water Filter Status Light

The water filter status lights will help you know when to change your water filter.

- The “Order Filter” status light will be illuminated when it is time to order a replacement filter.
- The “Replace Filter” status light will be illuminated when it is time to replace the filter.
- Replacing the disposable water filter with a new filter will automatically reset the filter status tracking feature. See “Using the Controls.”

NOTES:

- “Replace Filter” will remain illuminated if a filter is not installed.
- The “Filter” status light will flash if the filter is not correctly installed or there is an obstruction in the water line.

Replace the Water Filter

To purchase a replacement water filter, see “Accessories.”

Replace the disposable water filter when indicated on the water filter status display or at least every 9 months. If the ice making rate decreases before the Replace Filter light illuminates, then replace the filter.

1. Locate the water filter compartment in the right-hand side of the control housing. See Step 3 in the “Install Water Filter” section.
2. Turn the water filter counterclockwise (to the left), and pull it straight out of the compartment.

NOTE: There may be some water in the filter. Some spillage may occur.

3. Install the replacement water filter by following steps 2 through 5 in the “Install the Water Filter” section.

Normal Sounds

Your new ice maker may make sounds that are not familiar to you. Because the sounds are new to you, you might be concerned about them. Most of the new sounds are normal. Hard surfaces such as floors, walls and cabinets can make the sounds seem louder than they actually are. The following describes the kinds of sounds that might be new to you and what may be making them.

- You will hear a buzzing sound when the water valve opens to fill the water pan for each cycle.
- Rattling noises may come from the flow of the refrigerant or the water line. Items stored on top of the ice maker can also make noises.
- The high-efficiency compressor may make a pulsating or high pitched sound.
- Water running over the evaporator plate may make a splashing sound.
- Water running from the evaporator plate to the water pan may make a splashing sound.
- As each cycle ends, you may hear a gurgling sound due to the refrigerant flowing in your ice maker.
- You may hear air being forced over the condenser by the condenser fan.
- During the harvest cycle, you may hear a “thud” when the ice sheet slides from the evaporator onto the cutter grid.
- When you first start the ice maker, you may hear water running continuously. The ice maker is programmed to run a rinse cycle before it begins to make ice.
- If the ice maker is connected to a water supply pressure in excess of 60 psi, you may hear a loud sound during water filling associated with the flow of water through the inlet valve. Call a licensed, qualified plumber to determine the best method to reduce the supply water pressure (50 psi is recommended).

CARING FOR YOUR ICE MAKER

Cleaning

The ice making system and the air cooled condenser need to be cleaned regularly for the ice maker to operate at peak efficiency and to avoid premature failure of system components. See the “Ice Maker System” and the “Condenser” sections.

Exterior Surfaces

Wash the exterior enamel surfaces and gaskets with warm water and mild soap or detergent. Wipe and dry. Regular use of a good household appliance cleaner and wax will help maintain the finish. Do not use abrasive cleaners on enamel surfaces as they may scratch the finish.

For products with a stainless steel exterior, use a clean sponge or soft cloth and a mild detergent in warm water. Do not use abrasive or harsh cleaners. Do not use chlorine bleach on the stainless steel surfaces.

Ice Maker System

Minerals that are removed from water during the freezing cycle will eventually form a hard scaly deposit in the water system. Cleaning the system regularly helps remove the mineral scale buildup. How often you need to clean the system depends upon how hard your water is. With hard water of 15 to 20 grains/gal. (4 to 5 grains/liter), you may need to clean the system as often as every 9 months.

NOTE: Use one 16 oz (473 mL) bottle of approved ice maker cleaner. To order, see “Accessories.”

1. Press the ON/OFF button.
2. Wait 5 to 10 minutes for the ice to fall into the storage bin. Remove all ice from the storage bin.
3. Unscrew the drain cap from the bottom of the water pan located inside the storage bin as shown. Allow the water to drain completely.
4. Replace the drain cap securely on the water pan. If the drain cap is loose, water will empty from the water pan and you will have either thin ice or no ice.
5. Read and follow all handling information on the cleaner bottle before completing the steps below. Use one 16 oz (473 mL) bottle of approved ice maker cleaner.

- Pour one bottle of solution into the water pan. Fill the bottle twice with tap water and pour it into the water pan.

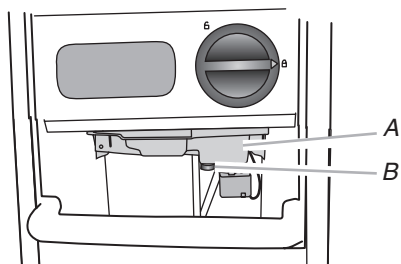

A. Water pan
B. Drain cap

- Press the CLEAN button. See “Using the Controls.” The light will blink, indicating that the cleaning cycle is in process. When the “Cleaning Complete” light is illuminated (approximately 70 minutes), the cleaning cycle is complete. During the cleaning cycle, the system will both clean and rinse itself.
- After the cleaning cycle is complete, remove the drain cap from the water pan. Look for any cleaning solution left in the water pan. If cleaning solution drains from the water pan, you should run the clean cycle again. Be sure to refill the water pan with cleaner before starting the clean cycle again. Be sure to replace the drain cap securely on the water pan. If the drain cap is loose, water will empty from the water pan and you will have either thin ice or no ice.

NOTE: Severe scale buildup may require repeated cleaning with a fresh quantity of cleaning solution.

- Press the ON/OFF button to resume ice production.

Condenser

A Dirty or Clogged Condenser

- Obstructs proper airflow.
- Reduces ice making capacity.
- Causes higher than recommended operating temperatures which may lead to component failure.

WARNING



Electrical Shock Hazard

- Disconnect power before cleaning.**
Replace all parts and panels before operating.
Failure to do so can result in death or electrical shock.

- Unplug ice maker or disconnect power.
- Remove the 2 screws in the lower access panel and the 2 screws from the base grille area of the front panel support.
- Pull the bottom forward and then pull down to remove the lower access panel.

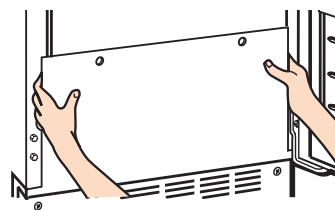

- Remove dirt and lint from the condenser fins and the unit compartment with a brush attachment on a vacuum cleaner.

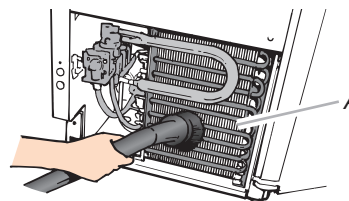

A. Condenser fins

- Replace the lower access panel using the 4 screws.
- Plug in ice maker or reconnect power.

ACCESSORIES

To order accessories, in the U.S.A., visit our web site www.maytag.com/accessories or call 1-800-901-2042.

In Canada, visit our web site www.whirlpoolparts.ca or call 1-800-807-6777.

Water Filter

Order Part Number F2WC9I1 or ICE2

Cleaner

Order Part Number 4396808

affresh®* Stainless Steel Cleaner

In U.S.A., order Part Number W10355016

In Canada, order Part Number W10355016B

affresh®* Stainless Steel Wipes

In U.S.A., order Part Number W10355049

In Canada, order Part Number W10355049B

affresh®* Kitchen & Appliance Cleaner

In U.S.A., order Part Number W10355010

In Canada, order Part Number W10355010B

*®affresh is a trademark of Whirlpool, U.S.A.

PROBLEM SOLVER



Scan the code at left with your mobile device, or visit https://www.maytag.com/product_help for more recommendations that may help you avoid a service call.

Ice Maker Operation

⚠ WARNING



Electrical Shock Hazard

Plug into a grounded 3 prong outlet.

Do not remove ground prong.

Do not use an adapter.

Do not use an extension cord.

Failure to follow these instructions can result in death, fire, or electrical shock.

PROBLEM	RECOMMENDED SOLUTIONS
Ice Maker Will Not Operate	<p>Check that it is plugged into a grounded 3 prong outlet.</p> <p>Check that the control is turned on.</p> <p>Replace the fuse or reset the circuit breaker.</p> <p>NOTE: If problems continue, contact an electrician.</p> <p>Room temperature must be above 55°F (13°C). Otherwise, bin thermostat may sense cold room temperature and shut off even though the bin is not full of ice. The ice maker may not restart once it does shut off.</p> <p>If there was a large amount of water added to the ice maker, wait a few minutes for the drain pump to clear. If there is still water in the bin, check to see whether the drain hose is kinked.</p> <p>For models with drain pumps, check that the drain hose is not damaged, or kinked or pinched between cabinet and ice maker. Use only Whirlpool approved drain pump kit, Part Number 1901A.</p>
Ice Maker Seems Noisy	<p>Water overflowing the reservoir is normal. This overflow helps to purge minerals that were removed from the water during the ice making process.</p> <p>If there is a “whooshing” sound, check the following things:</p> <ul style="list-style-type: none"> ■ Make sure that the water supply is hooked up and turned on. ■ Make sure that the drain cap is tight and the water drain pan pump is securely attached to the water pan. <p>If there is ice between the evaporator plate and the cutting grid, check that the ice maker is level. If the ice maker is level, and the problem persists, run a cleaning cycle.</p> <p>If the ice maker is connected to a water supply pressure in excess of 60 psi, you may hear a loud sound during water filling associated with the flow of water through the inlet valve. Call a licensed, qualified plumber to determine the best method to reduce the supply water pressure (50 psi is recommended).</p>

Ice Production



PROBLEM	RECOMMENDED SOLUTIONS
Ice Maker Runs But Produces No Ice	<p>Check that the control is turned on.</p> <p>Make sure the water supply is properly connected and turned on.</p> <p>If the drain cap is loose, water will empty from the water pan, and you will have either thin ice or no ice. Tighten the drain cap.</p> <p>Clean the drain tube.</p> <p>Check that there are no kinks in the drain line.</p>
Ice Maker Runs But Produces Very Little Ice	<p>If the accelerated ice production feature is turned on, this feature increases the ice production rate to provide you with more ice in the same amount of time.</p> <p>Room temperatures of more than 90°F (32°C) will normally reduce ice production.</p> <p>Dirt or lint may be blocking the airflow through the condenser.</p> <p>If there is white scale buildup in the ice maker's water or freezing system, you should clean the ice maker.</p> <p>If the drain cap is loose, water will empty from the water pan, and you will have either thin ice or no ice. Tighten the drain cap.</p> <p>Ensure that the cutter grid is securely in place and that its harness plug is connected.</p> <p>Check that water filter is properly installed.</p>

Ice Quality

PROBLEM	RECOMMENDED SOLUTIONS
Off Taste, Odor or Gray Color in the Ice	<p>If there is unusually high mineral content in the water supply, the water may need to be treated.</p> <p>If there is mineral scale buildup, clean your ice maker.</p> <p>Do not store any foods in the ice bin.</p> <p>Make sure that all packaging materials were removed at the time of installation.</p>
Thin, Soft or Clumps of Ice	<p>If there is unusually high mineral content in the water supply, the water may need to be treated.</p> <p>If there is mineral scale buildup, clean your ice maker.</p> <p>If there are clumps of ice in the bin and if ice is not used regularly, it will melt and form clumps. Break the clumps with the ice scoop provided.</p>

Plumbing Problems

⚠ WARNING

Excessive Weight Hazard

Use two or more people to move and install ice maker.

Failure to do so can result in back or other injury.

PROBLEM	RECOMMENDED SOLUTIONS
Water Not Entering Drain Properly	If the drain hose is not aligned over the drain, move the ice maker to align the drain. NOTE: Service technicians cannot repair plumbing problems outside of the ice maker. Call a licensed, qualified plumber.

PERFORMANCE DATA SHEET

Ice Maker Water Filtration System
Model P6GEG2KL, P6KG2KL, P6WG2KL Capacity 2000 Gallons (7571 Liters)



System tested and certified by NSF International against NSF/ANSI Standard 42 for the reduction of Chlorine Taste and Odor.

This system has been tested according to NSF/ANSI Standards 42 for the reduction of the substances listed below. The concentration of the indicated substances in water entering the system was reduced to a concentration less than or equal to the permissible limit for water leaving the system, as specified in NSF/ANSI Standards 42.

Substance Reduction Aesthetic Effects	NSF Reduction Requirements	Average Influent	Influent Challenge Concentration	Maximum Effluent	Average Effluent	Minimum % Reduction	Average % Reduction
Chlorine Taste/Odor	50% reduction	1.9727 mg/L	2.0 mg/L ± 10%	0.71 mg/L	0.7788 mg/L	70.2	72.81

Test Parameters: pH = 7.5 ± 0.5 unless otherwise noted. Flow = 0.50 gpm (1.89 Lpm). Pressure = 60 psig (413.7 kPa). Temp. = 68°F to 71.6°F (20°C to 22°C). Rated service capacity = 2000 gallons (7571 liters).

- It is essential that operational, maintenance, and filter replacement requirements be carried out for the product to perform as advertised.
- Use replacement filter P6RFG2K, P6RFEG2K, P6RFKG2K, Part Number ICE2.
- Style 1** – When the water filter status display changes from “GOOD” to “ORDER,” order a new filter. When the filter indicator reads “REPLACE,” it is recommended that you replace the filter.
- Style 2** – Press FILTER to check the status of your water filter. If the filter indicator light is yellow and the words “ORDER FILTER” appear on the display screen, order a new filter. If the filter indicator light is red, it is recommended that you replace the filter.
- These contaminants are not necessarily in your water supply. While testing was performed under standard laboratory conditions, actual performance may vary.
- The product is for cold water use only.
- Do not use with water that is microbiologically unsafe or of unknown quality without adequate disinfection before or after the system.
- Refer to the “Warranty” section for the Manufacturer’s name, address and telephone number.

- Refer to the “Warranty” section for the Manufacturer’s limited warranty.

Application Guidelines/Water Supply Parameters

Water Supply	City or Well
Water Pressure	30 - 120 psi (207 - 827 kPa)
Water Temperature	33° - 100°F (0.6° - 37.8°C)
Service Flow Rate	0.50 gpm (1.89 Lpm) @ 60 psi

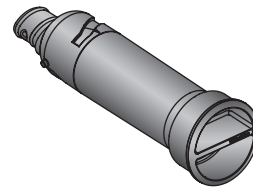

WARRANTY

MAYTAG® MAJOR APPLIANCE WARRANTY

LIMITED WARRANTY

For one year from the date of purchase, when this major appliance is operated and maintained according to instructions attached to or furnished with the product, Maytag brand of Whirlpool Corporation or Whirlpool Canada LP (hereafter "Maytag") will pay for factory specified parts and repair labor to correct defects in materials or workmanship. Service must be provided by a Maytag designated service company. This limited warranty is valid only in the United States or Canada and applies only when the major appliance is used in the country in which it was purchased. Outside the 50 United States and Canada, this limited warranty does not apply. Proof of original purchase date is required to obtain service under this limited warranty.

ITEMS EXCLUDED FROM WARRANTY

This limited warranty does not cover:

1. Service calls to correct the installation of your major appliance, to instruct you on how to use your major appliance, to replace or repair house fuses, or to correct house wiring or plumbing.
2. Service calls to repair or replace appliance light bulbs, air filters or water filters. Consumable parts are excluded from warranty coverage.
3. Repairs when your major appliance is used for other than normal, single-family household use or when it is used in a manner that is contrary to published user or operator instructions and/or installation instructions.
4. Damage resulting from accident, alteration, misuse, abuse, fire, flood, acts of God, improper installation, installation not in accordance with electrical or plumbing codes, or use of consumables or cleaning products not approved by Maytag.
5. Cosmetic damage, including scratches, dents, chips or other damage to the finish of your major appliance, unless such damage results from defects in materials or workmanship and is reported to Maytag within 30 days from the date of purchase.
6. Any food loss due to refrigerator or freezer product failures.
7. Costs associated with the removal from your home of your major appliance for repairs. This major appliance is designed to be repaired in the home and only in-home service is covered by this warranty.
8. Repairs to parts or systems resulting from unauthorized modifications made to the appliance.
9. Expenses for travel and transportation for product service if your major appliance is located in a remote area where service by an authorized Maytag servicer is not available.
10. The removal and reinstallation of your major appliance if it is installed in an inaccessible location or is not installed in accordance with published installation instructions.
11. Major appliances with original model/serial numbers that have been removed, altered or cannot be easily determined. This warranty is void if the factory applied serial number has been altered or removed from your major appliance.

The cost of repair or replacement under these excluded circumstances shall be borne by the customer.

DISCLAIMER OF IMPLIED WARRANTIES; LIMITATION OF REMEDIES

CUSTOMER'S SOLE AND EXCLUSIVE REMEDY UNDER THIS LIMITED WARRANTY SHALL BE PRODUCT REPAIR AS PROVIDED HEREIN. IMPLIED WARRANTIES, INCLUDING WARRANTIES OF MERCHANTABILITY OR FITNESS FOR A PARTICULAR PURPOSE, ARE LIMITED TO ONE YEAR OR THE SHORTEST PERIOD ALLOWED BY LAW. MAYTAG SHALL NOT BE LIABLE FOR INCIDENTAL OR CONSEQUENTIAL DAMAGES. SOME STATES AND PROVINCES DO NOT ALLOW THE EXCLUSION OR LIMITATION OF INCIDENTAL OR CONSEQUENTIAL DAMAGES, OR LIMITATIONS ON THE DURATION OF IMPLIED WARRANTIES OF MERCHANTABILITY OR FITNESS, SO THESE EXCLUSIONS OR LIMITATIONS MAY NOT APPLY TO YOU. THIS WARRANTY GIVES YOU SPECIFIC LEGAL RIGHTS, AND YOU MAY ALSO HAVE OTHER RIGHTS WHICH VARY FROM STATE TO STATE OR PROVINCE TO PROVINCE.

If outside the 50 United States and Canada, contact your authorized Maytag dealer to determine if another warranty applies.

10/12

For additional product information, in the U.S.A., visit www.maytag.com.

In Canada, visit www.maytag.ca.

If you do not have access to the Internet and you need assistance using your product or you would like to schedule service, you may contact Maytag at the number below.

Have your complete model number ready. You can find your model number and serial number on the label, located on the inside wall of the refrigerator compartment.

For assistance or service in the U.S.A., call 1-800-688-9900. In Canada, call 1-800-807-6777.

If you need further assistance, you can write to Maytag with any questions or concerns at the address below:

In the U.S.A.:

In Canada:

Maytag Brand Home Appliances
Customer eXperience Center
553 Benson Road
Benton Harbor, MI 49022-2692

Maytag Brand Home Appliances
Customer eXperience Centre
200 – 6750 Century Ave.
Mississauga, Ontario L5N 0B7

Please include a daytime phone number in your correspondence.

Please keep all provided instructions and your model number information for future reference.



User Guide

Ice Maker



LEARN MORE

In an effort to conserve natural resources, this ice maker includes a condensed User Guide. A complete User Guide can be downloaded at www.whirlpool.com/manuals. The model number is located on the inside of the ice maker.

In the U.S.A., register your ice maker at www.whirlpool.com.

In Canada, register your ice maker at www.whirlpool.ca.

Para una version de estas instrucciones en español, visite www.whirlpool.com.

Your safety and the safety of others are very important.

We have provided many important safety messages in this manual and on your appliance. Always read and obey all safety messages.



This is the safety alert symbol.

This symbol alerts you to potential hazards that can kill or hurt you and others.

All safety messages will follow the safety alert symbol and either the word "DANGER" or "WARNING."

These words mean:

DANGER

You can be killed or seriously injured if you don't immediately follow instructions.

WARNING

You can be killed or seriously injured if you don't follow instructions.

All safety messages will tell you what the potential hazard is, tell you how to reduce the chance of injury, and tell you what can happen if the instructions are not followed.

IMPORTANT SAFETY INSTRUCTIONS

WARNING: To reduce the risk of fire, electric shock, or injury when using your ice maker, follow these basic precautions:

- Plug into a grounded 3 prong outlet.
- Do not remove ground prong.
- Do not use an adapter.
- Do not use an extension cord.
- Disconnect power before cleaning.
- Disconnect power before servicing.
- Replace all parts and panels before operating.
- Use two or more people to move and install ice maker.

SAVE THESE INSTRUCTIONS

State of California Proposition 65 Warnings:

WARNING: This product contains one or more chemicals known to the State of California to cause cancer.

WARNING: This product contains one or more chemicals known to the State of California to cause birth defects or other reproductive harm.

OPERATING YOUR ICE MAKER

How Your Ice Maker Works

When you first start your ice maker, the water pan will fill and the system will rinse itself before starting to make ice. The rinsing process takes about 5 minutes.

Under normal operating conditions, the ice maker will cycle at preset temperatures. The ice level sensor located in the ice storage bin will monitor the ice levels.

IMPORTANT: If the water supply to the ice maker is turned off, be sure to set the ice maker control to OFF.

The Ice Making Process

1. Water is constantly circulated over a freezing plate. As the water freezes into ice, the minerals in the water are rejected. This produces a sheet of ice with a low mineral content.

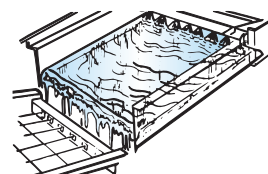

2. When the desired thickness is reached, the ice sheet is released and slides onto a cutter grid. The grid divides the sheet into individual cubes.

3. The water containing the rejected minerals is drained after each freezing cycle.

4. Fresh water enters the machine for the next ice making cycle.

5. Cubes fall into the storage bin. When the bin is full, the ice maker shuts off automatically and restarts when more ice is needed. The ice bin is not refrigerated, and some melting will occur. The amount of melting varies with room temperature.

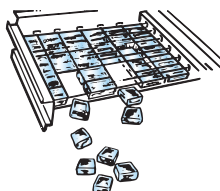
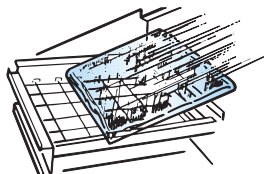

NOTE: As the room and water temperatures vary, so will the amount of ice produced and stored. This means that higher operating temperatures result in reduced ice production.

Using the Controls

1. To start ice production, press ON/OFF.
2. To stop ice maker operation, press ON/OFF.

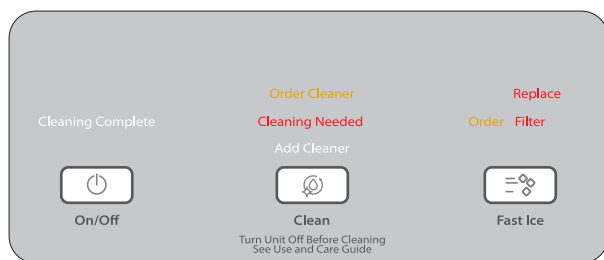

NOTES:

- Pressing the On/Off button does not shut off power to the ice maker.
- Allow 24 hours to produce the first batch of ice. Discard the first 2 batches produced.

Fast Ice Mode

Select the Fast Ice feature when you have an upcoming need for a large amount of ice and the ice bin is low or empty. Fast Ice mode will produce a greater quantity of ice in a 24-hour period.

- Press FAST ICE while the ice maker is on. The indicator light will illuminate.
- Press FAST ICE again to turn off the Fast Ice feature. The indicator light will turn off.
- The Fast Ice mode will be on when you first turn on the product. It will turn off after 24 hours. To turn Fast Ice back on, press FAST ICE.

Clean

It is recommended that you clean the ice maker when the "Cleaning Needed" light is illuminated or 9 months has elapsed or ice production decreases significantly. To clean your ice maker, see "Ice Maker System" in the "Cleaning" section.

Door Ajar Alarm

The Door Ajar Alarm feature sounds an alarm when the ice maker door is open for 5 minutes. The alarm will repeat every 2 minutes. Close the door to turn off. The feature then resets and will reactivate when the door is left open again for 5 minutes.

Water Filtration System

Do not use with water that is microbiologically unsafe or of unknown quality without adequate disinfection before or after the system. Systems certified for cyst reduction may be used on disinfected waters that may contain filterable cysts.

Install the Water Filter

1. Locate the accessory packet in the ice maker and remove the water filter.
2. Take the water filter out of its packaging and remove the cover from the O-rings. Be sure the O-rings are still in place after the cover is removed.

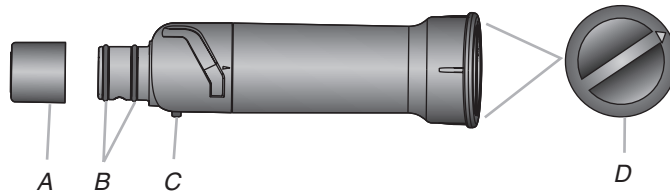

A. Cover C. Alignment pin
 B. O-rings D. Alignment arrow

3. The water filter compartment is located in the right-hand side of the ice maker controls.

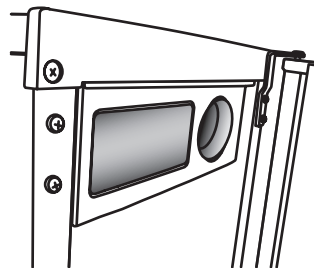

4. Using the arrow pointing to the alignment pin on the side of the filter and the arrow inside the control housing, align the alignment pin with the cutout notch and insert the filter into the housing.

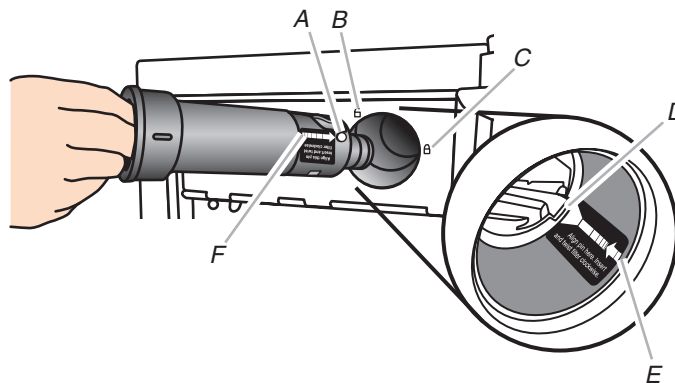

A. Alignment pin D. Cutout notch inside control housing
 B. Unlocked symbol E. Arrow pointing to cutout notch
 C. Locked symbol F. Arrow pointing to alignment pin

- Turn the filter clockwise until it locks into the housing. Ensure that the alignment arrow on the filter head aligns with the locked symbol on the control box housing.

NOTE: If the filter is not correctly locked into the housing, the ice maker will not produce ice.

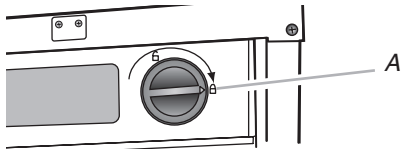

A. Alignment arrow aligned with locked symbol

The Water Filter Status Light

The water filter status lights will help you know when to change your water filter.

- The “Order Filter” status light will be illuminated when it is time to order a replacement filter.
- The “Replace Filter” status light will be illuminated when it is time to replace the filter.
- Replacing the disposable water filter with a new filter will automatically reset the filter status tracking feature. See “Using the Controls.”

NOTES:

- “Replace Filter” will remain illuminated if a filter is not installed.
- The “Filter” status light will flash if the filter is not correctly installed or there is an obstruction in the water line.

Replace the Water Filter

To purchase a replacement water filter, see “Accessories.”

Replace the disposable water filter when indicated on the water filter status display or at least every 9 months. If the ice making rate decreases before the Replace Filter light illuminates, then replace the filter.

- Locate the water filter compartment in the right-hand side of the control housing. See Step 3 in the “Install Water Filter” section.
- Turn the water filter counterclockwise (to the left), and pull it straight out of the compartment.

NOTE: There may be some water in the filter. Some spilling may occur.

- Install the replacement water filter by following steps 2 through 5 in the “Install the Water Filter” section.

Normal Sounds

Your new ice maker may make sounds that are not familiar to you. Because the sounds are new to you, you might be concerned about them. Most of the new sounds are normal. Hard surfaces such as floors, walls and cabinets can make the sounds seem louder than they actually are. The following describes the kinds of sounds that might be new to you and what may be making them.

- You will hear a buzzing sound when the water valve opens to fill the water pan for each cycle.
- Rattling noises may come from the flow of the refrigerant or the water line. Items stored on top of the ice maker can also make noises.
- The high-efficiency compressor may make a pulsating or high pitched sound.
- Water running over the evaporator plate may make a splashing sound.
- Water running from the evaporator plate to the water pan may make a splashing sound.
- As each cycle ends, you may hear a gurgling sound due to the refrigerant flowing in your ice maker.
- You may hear air being forced over the condenser by the condenser fan.
- During the harvest cycle, you may hear a “thud” when the ice sheet slides from the evaporator onto the cutter grid.
- When you first start the ice maker, you may hear water running continuously. The ice maker is programmed to run a rinse cycle before it begins to make ice.
- If the ice maker is connected to a water supply pressure in excess of 60 psi, you may hear a loud sound during water filling associated with the flow of water through the inlet valve. Call a licensed, qualified plumber to determine the best method to reduce the supply water pressure (50 psi is recommended).

CARING FOR YOUR ICE MAKER

Cleaning

The ice making system and the air cooled condenser need to be cleaned regularly for the ice maker to operate at peak efficiency and to avoid premature failure of system components. See the “Ice Maker System” and the “Condenser” sections.

Exterior Surfaces

Wash the exterior enamel surfaces and gaskets with warm water and mild soap or detergent. Wipe and dry. Regular use of a good household appliance cleaner and wax will help maintain the finish. Do not use abrasive cleaners on enamel surfaces as they may scratch the finish.

For products with a stainless steel exterior, use a clean sponge or soft cloth and a mild detergent in warm water. Do not use abrasive or harsh cleaners. Do not use chlorine bleach on the stainless steel surfaces.

Ice Maker System

Minerals that are removed from water during the freezing cycle will eventually form a hard scaly deposit in the water system. Cleaning the system regularly helps remove the mineral scale buildup. How often you need to clean the system depends upon how hard your water is. With hard water of 15 to 20 grains/gal. (4 to 5 grains/liter), you may need to clean the system as often as every 9 months.

NOTE: Use one 16 oz (473 mL) bottle of approved ice maker cleaner. To order, see “Accessories.”

- Press the ON/OFF button.
- Wait 5 to 10 minutes for the ice to fall into the storage bin. Remove all ice from the storage bin.
- Unscrew the drain cap from the bottom of the water pan located inside the storage bin as shown. Allow the water to drain completely.

4. Replace the drain cap securely on the water pan. If the drain cap is loose, water will empty from the water pan and you will have either thin ice or no ice.
5. Read and follow all handling information on the cleaner bottle before completing the steps below. Use one 16 oz (473 mL) bottle of approved ice maker cleaner.
6. Pour one bottle of solution into the water pan. Fill the bottle twice with tap water and pour it into the water pan.

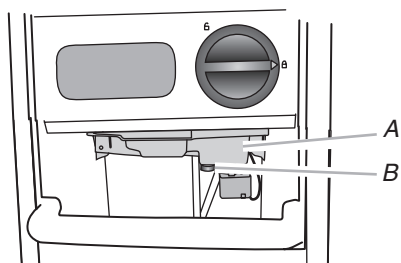

A. Water pan
B. Drain cap

7. Press the CLEAN button. See "Using the Controls." The light will blink, indicating that the cleaning cycle is in process. When the "Cleaning Complete" light is illuminated (approximately 70 minutes), the cleaning cycle is complete. During the cleaning cycle, the system will both clean and rinse itself.
8. After the cleaning cycle is complete, remove the drain cap from the water pan. Look for any cleaning solution left in the water pan. If cleaning solution drains from the water pan, you should run the clean cycle again. Be sure to refill the water pan with cleaner before starting the clean cycle again. Be sure to replace the drain cap securely on the water pan. If the drain cap is loose, water will empty from the water pan and you will have either thin ice or no ice.

NOTE: Severe scale buildup may require repeated cleaning with a fresh quantity of cleaning solution.

9. Press the ON/OFF button to resume ice production.

Condenser

A Dirty or Clogged Condenser

- Obstructs proper airflow.
- Reduces ice making capacity.
- Causes higher than recommended operating temperatures which may lead to component failure.

WARNING



Electrical Shock Hazard

Disconnect power before cleaning.
Replace all parts and panels before operating.
Failure to do so can result in death or electrical shock.

1. Unplug ice maker or disconnect power.
2. Remove the 2 screws in the lower access panel and the 2 screws from the base grille area of the front panel support.
3. Pull the bottom forward and then pull down to remove the lower access panel.

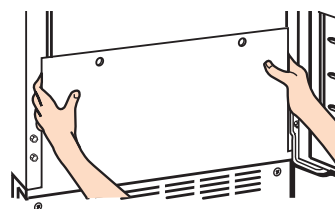

4. Remove dirt and lint from the condenser fins and the unit compartment with a brush attachment on a vacuum cleaner.

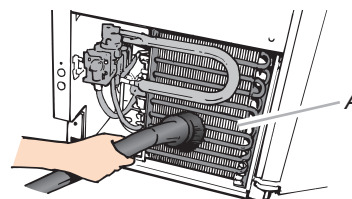

A. Condenser fins

5. Replace the lower access panel using the 4 screws.
6. Plug in ice maker or reconnect power.

ACCESSORIES

To order accessories, in the U.S.A., visit our web site www.whirlpool.com/accessories or call 1-800-901-2042.

In Canada, visit our web site www.whirlpoolparts.ca or call 1-800-807-6777.

Water Filter

Order Part Number F2WC911 or ICE2

Cleaner

Order Part Number 4396808

affresh® Stainless Steel Cleaner

In U.S.A., order Part Number W10355016

In Canada, order Part Number W10355016B

affresh® Stainless Steel Wipes

In U.S.A., order Part Number W10355049

In Canada, order Part Number W10355049B

affresh® Kitchen & Appliance Cleaner

In U.S.A., order Part Number W10355010

In Canada, order Part Number W10355010B

PROBLEM SOLVER



Scan the code at left with your mobile device, or visit www.whirlpool.com/product_help for recommendations that may help you avoid a service call.

Ice Maker Operation

⚠ WARNING

Electrical Shock Hazard

Plug into a grounded 3 prong outlet.

Do not remove ground prong.

Do not use an adapter.

Do not use an extension cord.

Failure to follow these instructions can result in death, fire, or electrical shock.

PROBLEM	RECOMMENDED SOLUTIONS
<p>Ice Maker Will Not Operate</p>	<p>Check that it is plugged into a grounded 3 prong outlet.</p> <p>Check that the control is turned on.</p> <p>Replace the fuse or reset the circuit breaker.</p> <p>NOTE: If problems continue, contact an electrician.</p> <p>Room temperature must be above 55°F (13°C). Otherwise, bin thermostat may sense cold room temperature and shut off even though the bin is not full of ice. The ice maker may not restart once it does shut off.</p> <p>If there was a large amount of water added to the ice maker, wait a few minutes for the drain pump to clear. If there is still water in the bin, check to see whether the drain hose is kinked.</p> <p>For models with drain pumps, check that the drain hose is not damaged, or kinked or pinched between cabinet and ice maker. Use only Whirlpool approved drain pump kit, Part #1901A.</p>
<p>Ice Maker Seems Noisy</p>	<p>Water overflowing the reservoir is normal. This overflow helps to purge minerals that were removed from the water during the ice making process.</p> <p>If there is a “whooshing” sound, check the following things:</p> <ul style="list-style-type: none"> ■ Make sure that the water supply is hooked up and turned on. ■ Make sure that the drain cap is tight and the water drain pan pump is securely attached to the water pan. <p>If there is ice between the evaporator plate and the cutting grid, check that the ice maker is level. If the ice maker is level, and the problem persists, run a cleaning cycle.</p> <p>If the ice maker is connected to a water supply pressure in excess of 60 psi, you may hear a loud sound during water filling associated with the flow of water through the inlet valve. Call a licensed, qualified plumber to determine the best method to reduce the supply water pressure (50 psi is recommended).</p>

Ice Production

⚠ WARNING

<p>Electrical Shock Hazard</p> <p>Disconnect power before servicing.</p> <p>Replace all parts and panels before operating.</p> <p>Failure to do so can result in death or electrical shock.</p>

PROBLEM	RECOMMENDED SOLUTIONS
Ice Maker Runs But Produces No Ice	<p>Check that the control is turned on.</p> <p>Check that the water supply is properly connected and turned on.</p> <p>If the drain cap is loose, water will empty from the water pan, and you will have either thin ice or no ice. Tighten the drain cap.</p> <p>Clean the drain tube.</p> <p>Check that there are no kinks in the drain line.</p>
Ice Maker Runs But Produces Very Little Ice	<p>If the accelerated ice production feature is turned on, this feature increases the ice production rate to provide you with more ice in the same amount of time.</p> <p>Room temperatures of more than 90°F (32°C) will normally reduce ice production.</p> <p>Dirt or lint may be blocking the airflow through the condenser.</p> <p>If there is white scale buildup in the ice maker's water or freezing system, you should clean the ice maker.</p> <p>If the drain cap is loose, water will empty from the water pan, and you will have either thin ice or no ice. Tighten the drain cap.</p> <p>Ensure that the cutter grid is securely in place and that its harness plug is connected.</p> <p>Check that water filter is properly installed.</p>

Ice Quality

PROBLEM	RECOMMENDED SOLUTIONS
Off Taste, Odor or Gray Color in the Ice	<p>If there is unusually high mineral content in the water supply, the water may need to be treated.</p> <p>If there is mineral scale buildup, clean your ice maker.</p> <p>Do not store any foods in the ice bin.</p> <p>Make sure that all packaging materials were removed at the time of installation.</p>
Thin, Soft or Clumps of Ice	<p>If there is unusually high mineral content in the water supply, the water may need to be treated.</p> <p>If there is mineral scale buildup, clean your ice maker.</p> <p>If there are clumps of ice in the bin and if ice is not used regularly, it will melt and form clumps. Break the clumps with the ice scoop provided.</p>

⚠ WARNING

Excessive Weight Hazard

Use two or more people to move and install ice maker.
Failure to do so can result in back or other injury.

PROBLEM	RECOMMENDED SOLUTIONS
Water Not Entering Drain Properly	If the drain hose is not aligned over the drain, move the ice maker to align the drain. NOTE: Service technicians cannot repair plumbing problems outside of the ice maker. Call a licensed, qualified plumber.

PERFORMANCE DATA SHEET

Ice Maker Water Filtration System Model P6GEG2KL, P6KG2KL, P6WG2KL Capacity 2000 Gallons (7571 Liters)



System tested and certified by NSF International against NSF/ANSI Standard 42 for the reduction of Chlorine Taste and Odor.

This system has been tested according to NSF/ANSI Standards 42 for the reduction of the substances listed below. The concentration of the indicated substances in water entering the system was reduced to a concentration less than or equal to the permissible limit for water leaving the system, as specified in NSF/ANSI Standards 42.

Substance Reduction	NSF Reduction Requirements	Average Influent	Influent Challenge Concentration	Maximum Effluent	Average Effluent	Minimum % Reduction	Average % Reduction
Chlorine Taste/Odor	50% reduction	1.9727 mg/L	2.0 mg/L ± 10%	0.71 mg/L	0.7788 mg/L	70.2	72.81

Test Parameters: pH = 7.5 ± 0.5 unless otherwise noted. Flow = 0.50 gpm (1.89 Lpm). Pressure = 60 psig (413.7 kPa). Temp. = 68°F to 71.6°F (20°C to 22°C). Rated service capacity = 2000 gallons (7571 liters).

- It is essential that operational, maintenance, and filter replacement requirements be carried out for the product to perform as advertised.
- Use replacement filter P6RFG2K, P6RFEG2K, P6RFKG2K, Part Number ICE2.
Style 1 – When the water filter status display changes from “GOOD” to “ORDER,” order a new filter. When the filter indicator reads “REPLACE,” it is recommended that you replace the filter.
Style 2 – Press FILTER to check the status of your water filter. If the filter indicator light is yellow and the words “ORDER FILTER” appear on the display screen, order a new filter. If the filter indicator light is red, it is recommended that you replace the filter.
- These contaminants are not necessarily in your water supply. While testing was performed under standard laboratory conditions, actual performance may vary.
- The product is for cold water use only.
- Do not use with water that is microbiologically unsafe or of unknown quality without adequate disinfection before or after the system.
- Refer to the “Warranty” section for the Manufacturer’s name, address and telephone number.

- Refer to the “Warranty” section for the Manufacturer’s limited warranty.

Application Guidelines/Water Supply Parameters

Water Supply	City or Well
Water Pressure	30 - 120 psi (207 - 827 kPa)
Water Temperature	33° - 100°F (0.6° - 37.8°C)
Service Flow Rate	0.50 gpm (1.89 Lpm) @ 60 psi

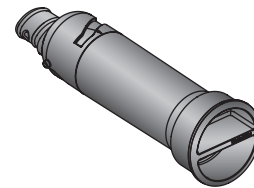

WARRANTY

WHIRLPOOL CORPORATION MAJOR APPLIANCE WARRANTY

LIMITED WARRANTY

For one year from the date of purchase, when this major appliance is operated and maintained according to instructions attached to or furnished with the product, Whirlpool Corporation or Whirlpool Canada LP (hereafter "Whirlpool") will pay for Factory Specified Parts and repair labor to correct defects in materials or workmanship. Service must be provided by a Whirlpool designated service company. This limited warranty is valid only in the United States or Canada and applies only when the major appliance is used in the country in which it was purchased. Outside the 50 United States and Canada, this limited warranty does not apply. Proof of original purchase date is required to obtain service under this limited warranty.

ITEMS EXCLUDED FROM WARRANTY

This limited warranty does not cover:

1. Service calls to correct the installation of your major appliance, to instruct you on how to use your major appliance, to replace or repair house fuses, or to correct house wiring or plumbing.
2. Service calls to repair or replace appliance light bulbs, air filters or water filters. Consumable parts are excluded from warranty coverage.
3. Repairs when your major appliance is used for other than normal, single-family household use or when it is used in a manner that is contrary to published user or operator instructions and/or installation instructions.
4. Damage resulting from accident, alteration, misuse, abuse, fire, flood, acts of God, improper installation, installation not in accordance with electrical or plumbing codes, or use of consumables or cleaning products not approved by Whirlpool.
5. Cosmetic damage, including scratches, dents, chips or other damage to the finish of your major appliance, unless such damage results from defects in materials or workmanship and is reported to Whirlpool within 30 days from the date of purchase.
6. Any food loss due to refrigerator or freezer product failures.
7. Costs associated with the removal from your home of your major appliance for repairs. This major appliance is designed to be repaired in the home and only in-home service is covered by this warranty.
8. Repairs to parts or systems resulting from unauthorized modifications made to the appliance.
9. Expenses for travel and transportation for product service if your major appliance is located in a remote area where service by an authorized Whirlpool servicer is not available.
10. The removal and reinstallation of your major appliance if it is installed in an inaccessible location or is not installed in accordance with published installation instructions.
11. Major appliances with original model/serial numbers that have been removed, altered or cannot be easily determined. This warranty is void if the factory applied serial number has been altered or removed from your major appliance.

The cost of repair or replacement under these excluded circumstances shall be borne by the customer.

DISCLAIMER OF IMPLIED WARRANTIES; LIMITATION OF REMEDIES

CUSTOMER'S SOLE AND EXCLUSIVE REMEDY UNDER THIS LIMITED WARRANTY SHALL BE PRODUCT REPAIR AS PROVIDED HEREIN. IMPLIED WARRANTIES, INCLUDING WARRANTIES OF MERCHANTABILITY OR FITNESS FOR A PARTICULAR PURPOSE, ARE LIMITED TO ONE YEAR OR THE SHORTEST PERIOD ALLOWED BY LAW. WHIRLPOOL SHALL NOT BE LIABLE FOR INCIDENTAL OR CONSEQUENTIAL DAMAGES. SOME STATES AND PROVINCES DO NOT ALLOW THE EXCLUSION OR LIMITATION OF INCIDENTAL OR CONSEQUENTIAL DAMAGES, OR LIMITATIONS ON THE DURATION OF IMPLIED WARRANTIES OF MERCHANTABILITY OR FITNESS, SO THESE EXCLUSIONS OR LIMITATIONS MAY NOT APPLY TO YOU. THIS WARRANTY GIVES YOU SPECIFIC LEGAL RIGHTS, AND YOU MAY ALSO HAVE OTHER RIGHTS WHICH VARY FROM STATE TO STATE OR PROVINCE TO PROVINCE.

If outside the 50 United States and Canada, contact your authorized Whirlpool dealer to determine if another warranty applies.

6/12

For additional product information, in the U.S.A., visit www.whirlpool.com.
In Canada, visit www.whirlpool.ca.

If you do not have access to the Internet and you need assistance using your product or you would like to schedule service, you may contact Whirlpool at the number below.

Have your complete model number ready. You can find your model number and serial number on the label, located on the inside wall of the refrigerator compartment.

For assistance or service in the U.S.A., call 1-800-253-1301. In Canada, call 1-800-807-6777.

If you need further assistance, you can write to Whirlpool with any questions or concerns at the address below:

In the U.S.A.:

Whirlpool Brand Home Appliances
Customer eXperience Center
553 Benson Road
Benton Harbor, MI 49022-2692

In Canada:

Whirlpool Brand Home Appliances
Customer eXperience Centre
200 – 6750 Century Ave.
Mississauga, Ontario L5N 0B7

Please include a daytime phone number in your correspondence.

Please keep all provided instructions and your model number information for future reference.

Section 4: Theory of Operation

This section provides general information concerning the theory of operation for Design 15" and 18" Ice Makers.

- Operating Systems
 - Refrigeration System
 - Water System
 - Electrical System
 - Operational Modes

THEORY OF OPERATION

Operating Systems

⚠ WARNING



Electrical Shock Hazard

Disconnect power before servicing.

Replace all parts and panels before operating.

Failure to do so can result in death or electrical shock.

There are three operating systems in the ice maker:

- Refrigeration System
- Water System
- Electrical System

REFRIGERATION SYSTEM

The refrigeration system in the ice maker is very similar to the system used in other refrigeration appliances. The refrigerant used in this unit is R134a.

There are two very important additions to the refrigeration system in the ice maker: the Hot Gas Valve, and the Condenser Accumulator Tube. The components operate as follows:

- Hot Gas Valve - Allows high pressure refrigerant gas to bypass the condenser and flow through the condenser accumulator tube.
- Condenser Accumulator Tube - Hot gas pushes liquid refrigerant through the accumulator tube into the evaporator, helping to evenly heat the evaporator plate so that the ice slab releases quickly and evenly.

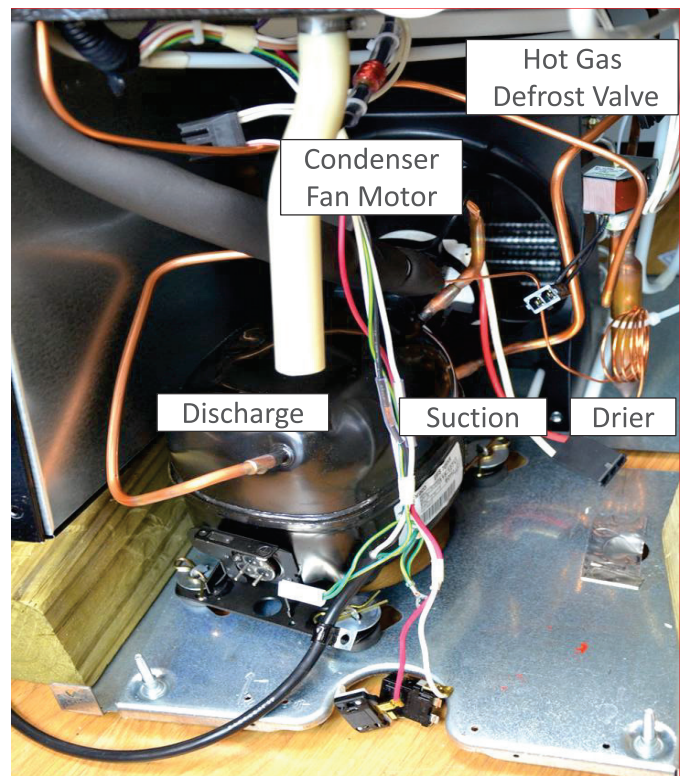

Operating Systems (Cont.)

EXAMPLE of Ice Maker Sealed System

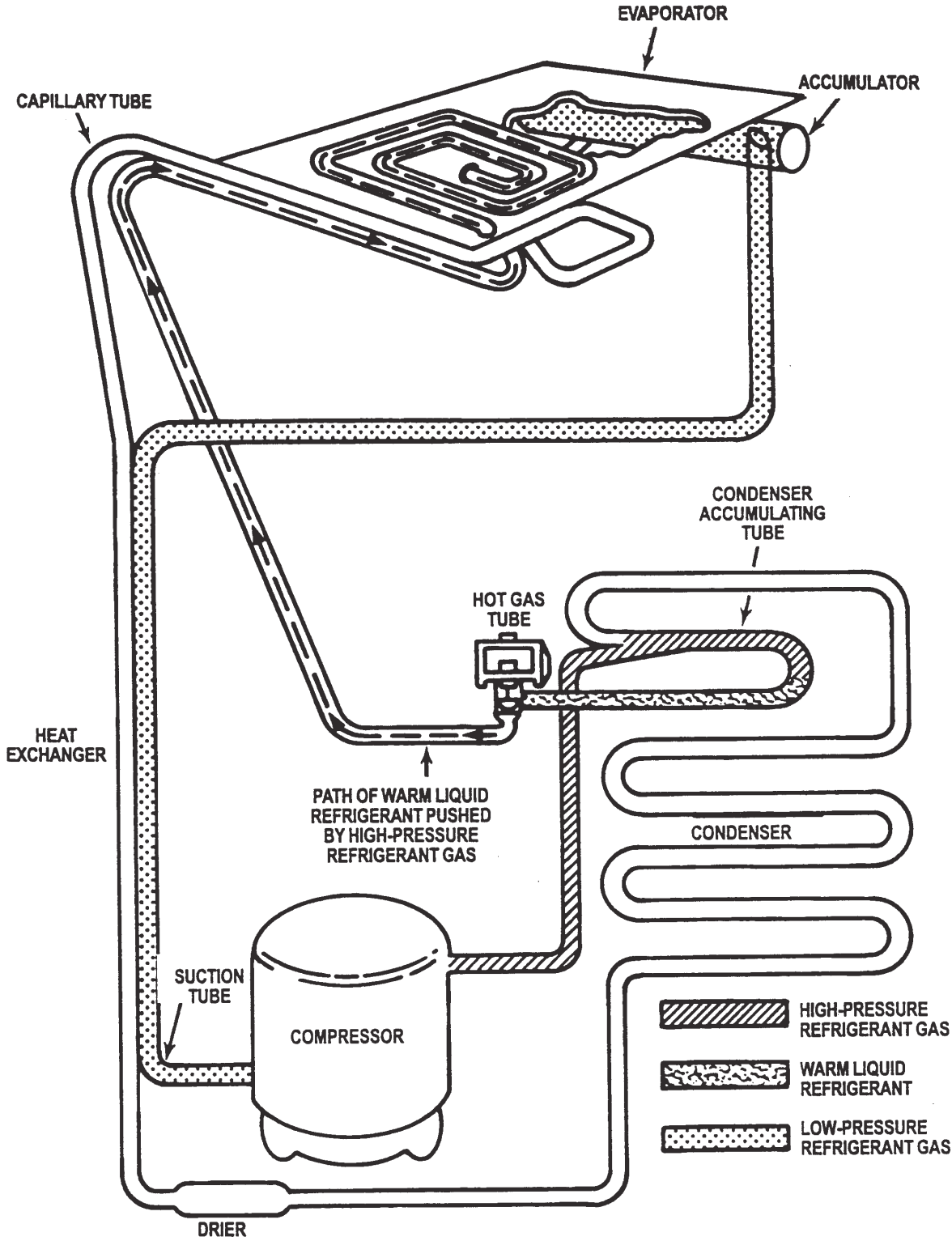

THEORY OF OPERATION

Operating Systems (Cont.)

WATER SYSTEM

The water system provides:

- Fresh water for ice production
- Water recirculation as ice is produced
- Water removal after ice is produced

The water system circulates water to freeze into ice on the evaporator during the freeze cycle. During the harvest cycle, it drains away minerals and contaminants. During the clean cycle, cleaning solution is circulated to clean the system of minerals and contaminants.

The hardness of the water supplied to the ice maker will affect the quality of the ice that is produced. It may also affect the operation of the water system.

A water softener, or poly phosphate feeder, will not cure all of the problems associated with hard water, but they can be used to reduce scale buildup in the ice maker. **NOTE:** Some poly phosphate feeders will cause a slime buildup in the water system when the water supply has a low mineral content.

ELECTRICAL SYSTEM

There are 2 new components on this Ice Maker. An inductor (coil) is wired in series (red wire) with the condenser fan motor. Its purpose in life is to smooth out voltage spikes. The unit Thermistor (2 white wires) signals the control board if the temperature of the machine compartment exceeds 115 degrees F. If it does, then during the next harvest cycle the condenser fan remains on to cool the area. 5 VDC is supplied to the Thermistor.

EXAMPLE of Ice Maker Water System

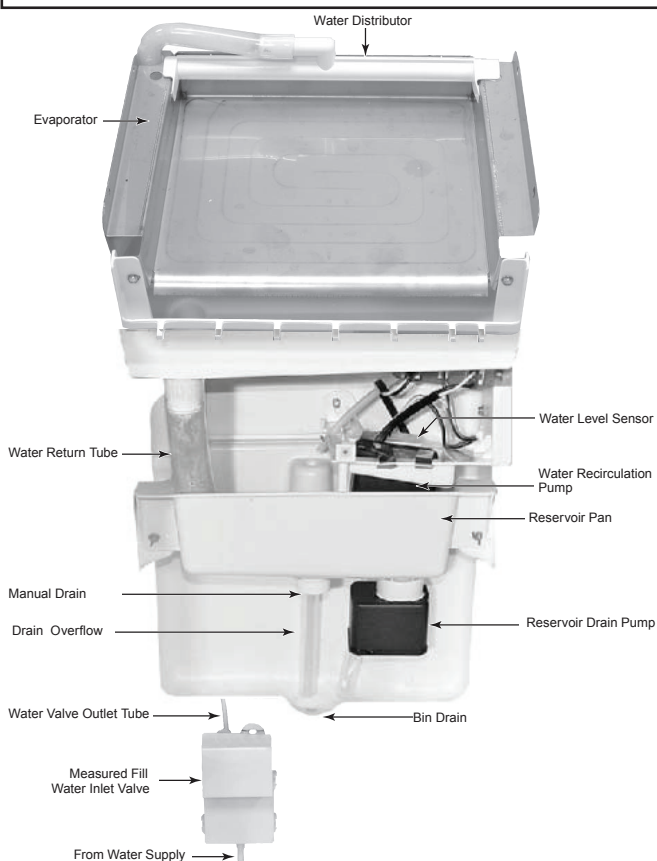

Operating Systems (Cont.)

OPERATIONAL MODES

There are four main operational modes for the ice maker (more detailed operation is found in the flow chart on page 6-5):

- Freeze
- Harvest
- Clean
- Service (Diagnostics)

ICE MAKING CYCLE

In addition, there are two possible "Off" cycles for the ice maker. They occur when:

1. The bin is full of ice and the LED is illuminated "ON/OFF" (Idle mode).
2. The "ON/OFF" button has been pressed. The ON/OFF LED will go out.

Electrical System

Line Voltage is supplied to the electrical control switches and the primary side of the step-down dual transformer. The dual transformer reduces 120 VAC to 9.4 VAC for the cutter grid, 14 VDC for the bin light and 12 VAC for the drain and recirculating pumps. The electronic control board directs 12 VAC to the water recirculating and reservoir drain pumps, and 120 VAC to the hot gas solenoid, condenser fan motor, water valve, and compressor. An evaporator thermistor supplies temperature information to the electronic control to determine when to terminate the harvest cycle.

Refrigeration System

The hot gas refrigerant, under high pressure, is forced through the condenser, where it changes into a liquid, and flows through the drier and capillary tube into the evaporator. Under low pressure in the evaporator, the liquid refrigerant absorbs heat from the water flowing over the evaporator as the refrigerant evaporates into a gas. As a low pressure gas, the refrigerant flows back through the suction line of the heat exchanger, to the compressor.

During the Freeze mode, some of the hot gas that is in the condenser accumulating tube, condenses to a liquid, and remains in the accumulating tube.

During the later stages of the Freeze mode, as the ice slab forms on the evaporator freezing plate, some of the refrigerant passing through the evaporator will not evaporate into a gas, but will remain a liquid. This liquid refrigerant will settle in the accumulator, while the refrigerant vapor is sucked off through the suction tube at the top of the accumulator. This accumulated liquid refrigerant will eventually be directed to the evaporator to quickly warm the evaporator plate during the Harvest mode.

NOTE: It is very important that the accumulator is not tilted out of a horizontal position. If moved, it could cause compressor failure.

Water System

The water recirculating pump moves the water from the reservoir pan up to the distributor, where it flows out over the evaporator freezing plate.

Water that does not freeze on the evaporator plate runs off the front edge, and falls back into the reservoir, where it is recirculated back to the water distributor.

As the ice slab forms, the minerals in the water are on the surface of the ice. The water flowing over the top of the ice slab washes these minerals back into the water reservoir pan. The water continues to recirculate until the water level in the reservoir drops to the bottom of the water level sensor. When the water level in the reservoir drops below the sensor, the control terminates the freeze mode and initiates the harvest mode.

The control signals the water valve to fill to the selected water level setting. The touch sensor is used to accurately fill to the correct volume. Depending on the ice thickness setting the fill level is calculated by the amount of time it takes the water to reach the touch sensor with a max time of 3 min. Thin Ice uses 35 ounces (1035cc), Normal Ice 38.9 ounces (1153cc), and Thick Ice 40.9 ounces (1212cc).

Operating Systems (Cont.)

HARVEST MODE

Electrical System

When the water level in the reservoir drops below the water level sensor it signals the electronic control to terminate power to the condenser fan (if unit thermistor is below 115°F) and then the water recirculating pump. The reservoir drain pump is activated to fully drain the reservoir. Power is then supplied to the water valve once. The fill valve fills to the requested volume, and the hot gas valve is energized. The hot gas valve is energized until the evaporator thermistor reaches 52°F. If the evaporator thermistor is unplugged, the evaporator defaults to a timed 4 minute harvest.

If the water level sensor is disconnected or open, the control defaults to 25 minutes of freeze time. The cleaning indicator LED feature will not function if the water level sensor is disconnected.

Refrigeration System

The hot gas valve opens, allowing high pressure refrigerant gas to bypass the condenser, and flow through the condenser accumulating tube. The hot gas pushes the liquid refrigerant that has accumulated in the accumulator tube up into the evaporator. The hot liquid refrigerant evenly heats the evaporator plate so that the ice slab releases quickly and evenly.

The ice slab, when released, slides off of the evaporator plate onto the cutter grid.

Water System

The electronic control board sends a signal to the water valve. The signal tells the water valve how much water to be filled, allowing water to flow into the water reservoir pan. The water fill volume is determined by the ice thickness setting.

As a result of the hot gas flow and the ice sliding off the evaporator plate, the evaporator temperature begins to rise. When the evaporator thermistor reaches the set temperature (52°F), or 33.8°F when the unit thermistor is above 115°F, the unit switches to the Freeze mode. This cycling between Freeze and Harvest, continues until the ice bin is full.

The electronic control board operates the various components and systems in the ice maker for each of the Freeze and Harvest modes.

CLEAN MODE

Electrical System

The electronic control board operates the various components and systems during the Clean mode.

For the order of the components cycled, see the flow chart on page 6-13.

Water System

When the service control switch is in the “Clean” position, the water recirculating pump circulates the cleaning solution that has been added to the reservoir, up to the water distributor, across the evaporator, and back into the reservoir, where it is recirculated. The compressor and hot gas valve operate to heat the evaporator.

DIAGNOSTIC MODE

1. Do not continue with the diagnosis of the ice maker if a fuse is blown, a circuit breaker is tripped, or if there is less than a 120 volt power supply at the wall outlet.
2. All units that have failed during the first few days of use should be checked for loose connections or miswiring.

Entering and Navigating — Manual Diagnostics

- Turn the product on. Within 10 seconds of Power On, press and hold the On and the Clean button. Release both buttons when all user interface LEDs begin to flash.
- Within 5 seconds of all LEDs flashing, push Max Ice (Fast Ice) button on the user interface. This begins manual diagnostics.
- If no button is pressed within 5 seconds, the product goes into the automatic diagnostic mode used at the assembly plant. Each component is cycled for 5 seconds.
- The Max Ice (or Acceler Ice button on some models) is used to advance through each step.
- To exit manual diagnostics, press the ON/OFF button.

Section 5: Component Access

This section provides service parts access, removal and installation information concerning Design 15" and 18" Ice Maker. Refer to the Repair Parts List for your specific model to see what parts are available for ordering. Access may be shown to some assemblies that can be disassembled further.

- Front Grille Components
 - Leveling Legs
 - Access the Water Valve and Tech Sheet
 - Removing the Water Valve
- Ice Bin Components
 - Door Removal/Reversal - Side Swing Only
 - Ice Bin Door Removal
 - Door Gasket Service
 - Removing Reservoir Cover
 - Heater Grid Removal
 - Removing the Bin Thermistor
 - Accessing Ice Bin Electrical Connections
 - Removing Reservoir and Pumps
 - Removing Recirculation Pump
 - Removing Water Level Sensor
 - Removing Drain Pump
- Ice Maker Top Components
 - Removing Top
 - Accessing the Control Compartment
 - Removing Transformer
 - Removing User Interface Board
 - Removing Main Control Board
- Machine Compartment Components
 - Accessing Machine Compartment
 - Fan Inductor and Thermistor
 - Condensate Pump Removal
 - Raising Cabinet to Access Components

COMPONENT ACCESS

Front Grille Components

⚠ WARNING



Electrical Shock Hazard
Disconnect power before servicing.
Replace all parts and panels before operating.
Failure to do so can result in death or electrical shock.

Tools needed

1/4" NUT DRIVER
T15[®] TORX^{®†}
T20[®] TORX^{®†}
T25[®] TORX^{®†}
STRAIGHT BLADE DRIVER
PHILLIPS HEAD DRIVER
NEEDLE NOSE PLIERS
CHANNEL LOCK PLIERS
VOM
NEEDLE POINT PROBES

NOTE: Needle point meter probes must be used for checking voltages on electronic boards

† - TORX[®] and T15[®], T20[®], T25[®] are registered trademarks of Acument Intellectual Properties, LLC.

LEVELING LEGS

Ice Maker is equipped with 4 leveling legs. Level unit side to side and front to back for uniform cube size.



FIGURE 1

ACCESS THE WATER VALVE AND TECH SHEET

1. Unplug ice maker or disconnect power.
2. To access the water valve and tech sheet start by removing the 4 screws holding grille. Pull out on the bottom of the grill and then down. See *Figure 2*.

NOTE: It may be necessary to push back on the top of the ice maker to drop and remove the front cover from the hinge plate. Make sure the white divider is in place to prevent condenser air bypass.

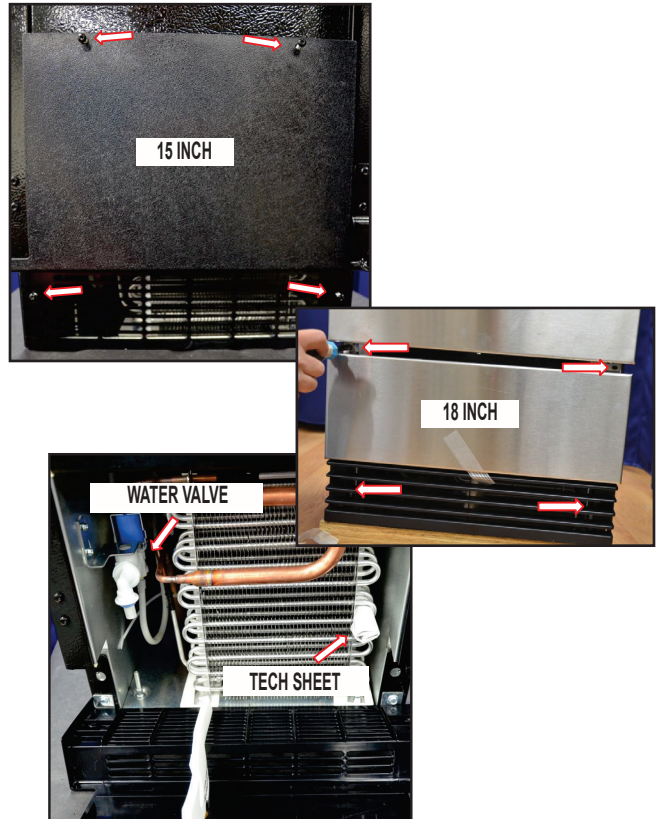

FIGURE 2

REMOVING THE WATER VALVE

3. Remove the screw. See *Figure 3*.



FIGURE 3

Ice Bin Components

4. Release the quick connect and disconnect the water tube. See *Figure 4*.



FIGURE 4

5. Pull out the water valve and disconnect the rear water tube and electrical connection. See *Figure 5*.

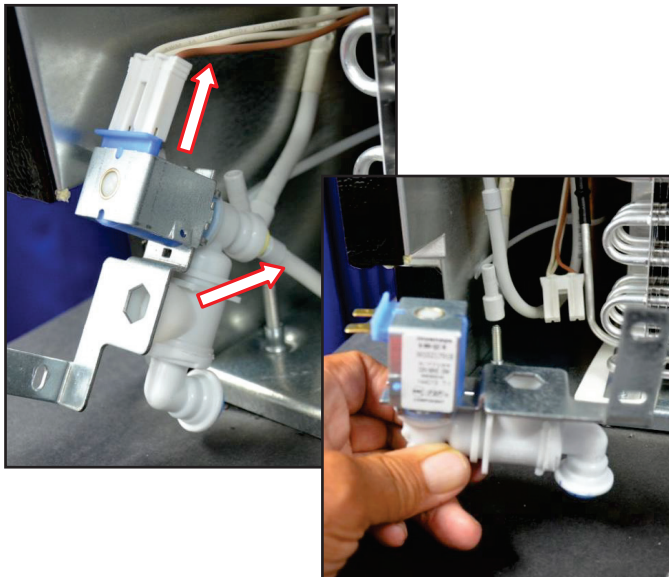

FIGURE 5

DOOR REMOVAL/REVERSAL - SIDE SWING ONLY

1. See Installation Instructions on Page 2-9.

ICE BIN DOOR REMOVAL

1. Unplug ice maker or disconnect power.
2. Support the door so it doesn't get damaged during the removal process. Use pliers to remove the left and right side door springs. Remove 2 screws on the left and right side hinge plates and remove door. See *Figure 6*.

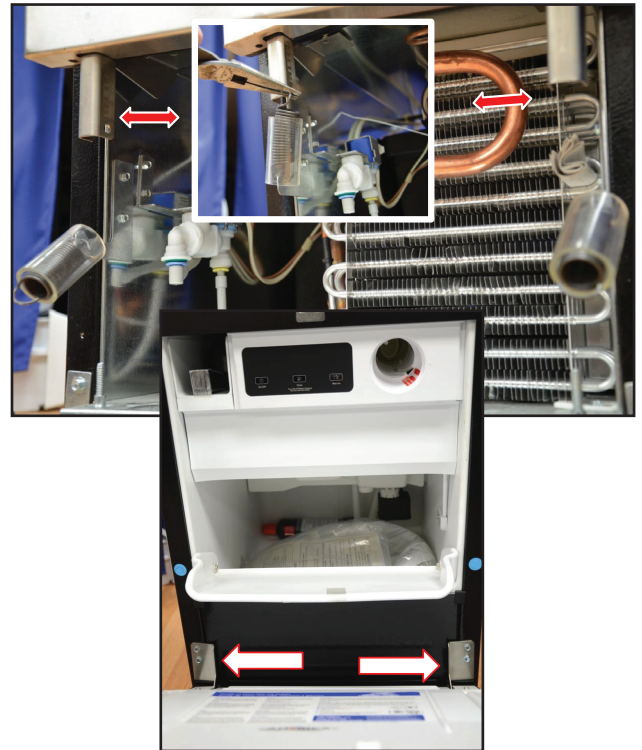

FIGURE 6

DOOR GASKET SERVICE

3. The door gasket can be replaced on any style and size ice maker by simply pulling off the old gasket and inserting the new one in its place.

NOTE: The door does not need to be removed from the product to accomplish this. See *Figure 7*.



FIGURE 7

COMPONENT ACCESS

Ice Bin Components (cont.)

REMOVING RESERVOIR COVER

NOTE: The reservoir cover on a 15" swing door ice maker simply unsnaps to remove. The cover on a 18" ice maker has 2 screws securing it to the control housing.

4. Remove the 2 screws located on the bottom of the cover. See *Figure 8*.



FIGURE 8

5. Lift up the ice scoop storage compartment as you pull out on the bottom of the cover. See *Figure 9*.

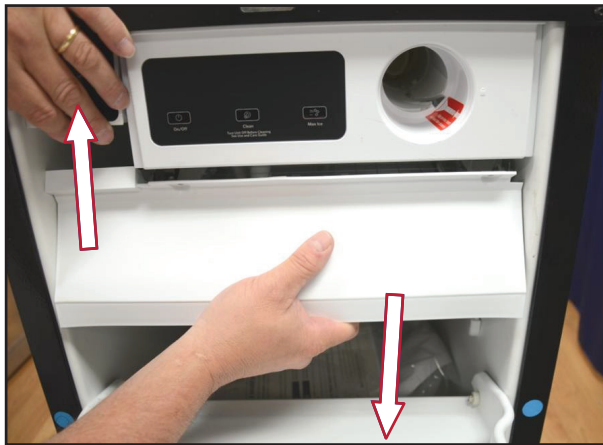

FIGURE 9

HEATER GRID REMOVAL

6. Remove the left and right side hex head screws and disconnect the left and right side wire harnesses. Slide out the heater assembly.

NOTE: A visual check and a resistance can be made of the heater wire. The heater grid operates on 9.4 VAC. Resistance is 5 OHMS. See *Figure 10*.



FIGURE 10

REMOVING THE BIN THERMISTOR

7. Remove 1 screw and the thermistor. See *Figure 11*.

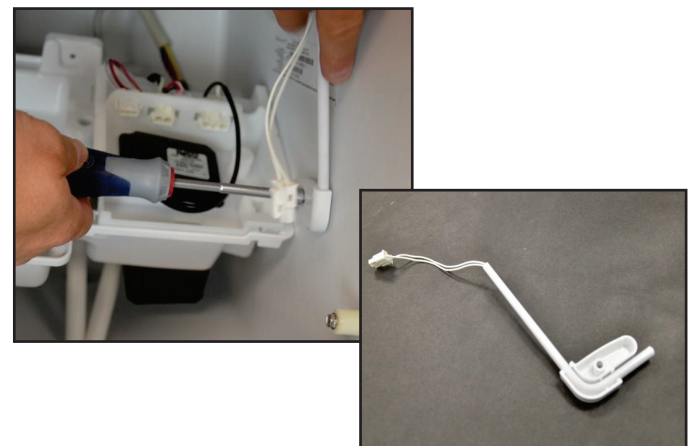

FIGURE 11

Ice Bin Components (cont.)

ACCESSING ICE BIN ELECTRICAL CONNECTIONS

- Remove the water tube from the left side of the cover and roll cover up and out. See *Figure 12*.



FIGURE 12

- Remove wire harnesses. See *Figure 13*.

NOTE: If one of the pumps is not functioning during the diagnostic check a resistance reading can be made.

Approximately 3.6 OHMS of resistance should be measured across the recirculation pump and the drain pump.

If a pump checks good but did not operate during the diagnostic test – make sure all the connections are tight and retry the operation before replacing the pump.

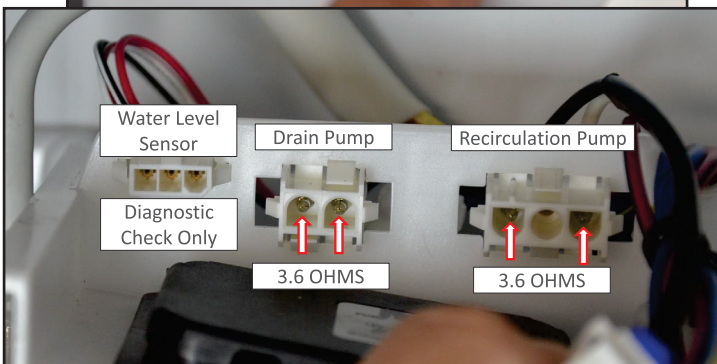
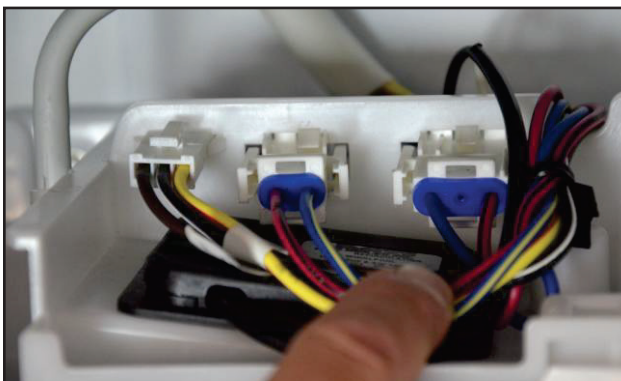

FIGURE 13

REMOVING RESERVOIR AND PUMPS

- Remove 1 hex head screw and remove the reservoir assembly. Remove wire harness. See *Figure 14*.

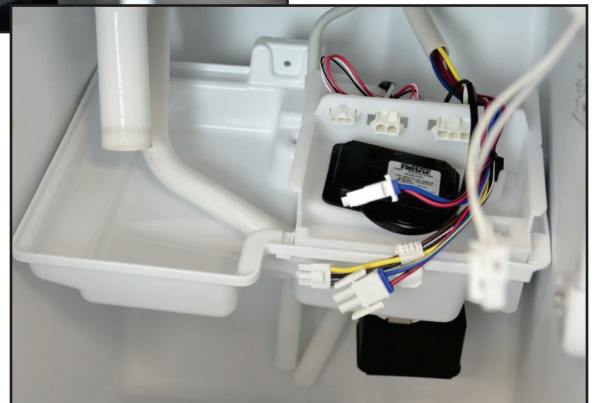

FIGURE 14

- Use a pair of pliers to remove christmas tree retainers. See *Figure 15*.

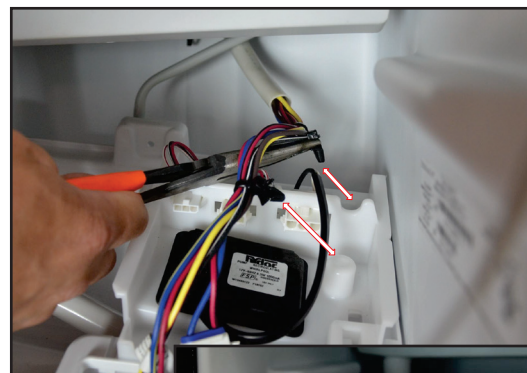

FIGURE 15

COMPONENT ACCESS

Ice Bin Components (cont.)

REMOVING RECIRCULATION PUMP

12. Remove the harness connection. Release the pump retainer. Press out the pump.

NOTE: The pump operates on 12 VAC. Resistance is 3.6 OHMS. See *Figure 16*.



FIGURE 16

REMOVING WATER LEVEL SENSOR

13. Disengage the water level switch from the housing. Remove the wire harness connector.

NOTE: The water level sensor cannot be checked with a meter - use the diagnostic program step #10. See *Figure 17*.

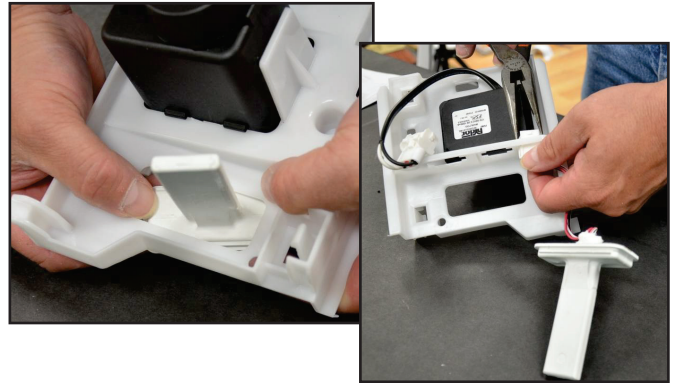

FIGURE 17

REMOVING DRAIN PUMP

14. Remove screw and pump.

NOTE: It's normal for the impeller and stator to separate when removed. If the pump is going to be reassembled for use - check the seals. See *Figure 18*.

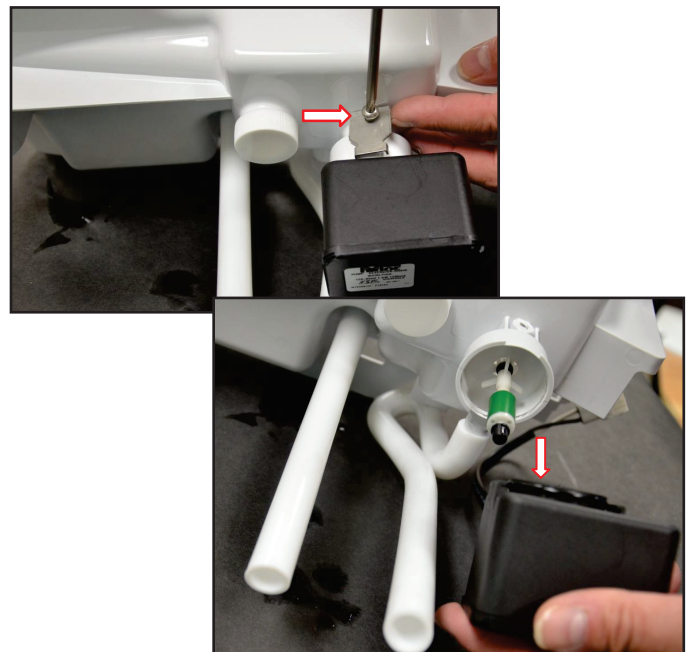



FIGURE 18

Notes

Ice Maker Top Components

⚠ WARNING



Electrical Shock Hazard
 Disconnect power before servicing.
 Replace all parts and panels before operating.
 Failure to do so can result in death or electrical shock.

REMOVING TOP

1. Unplug ice maker or disconnect power.
NOTE: To access control board, UI board, transformer or water level switch, the top must be removed. To remove the top, the swing door must be removed first. See Installation Instructions on Page 2-9.
2. Begin by removing the 2 Phillips head screws in the top front of the machine. See *Figure 19*.



FIGURE 19

3. Remove the 2 hex head screws located in the back of the unit. Raise the top.

NOTE: Lay a board across the cabinet under the top and then cover with a protective blanket. The board and blanket are needed to provide a working area when the control compartment is separated from the top. See *Figure 20*.

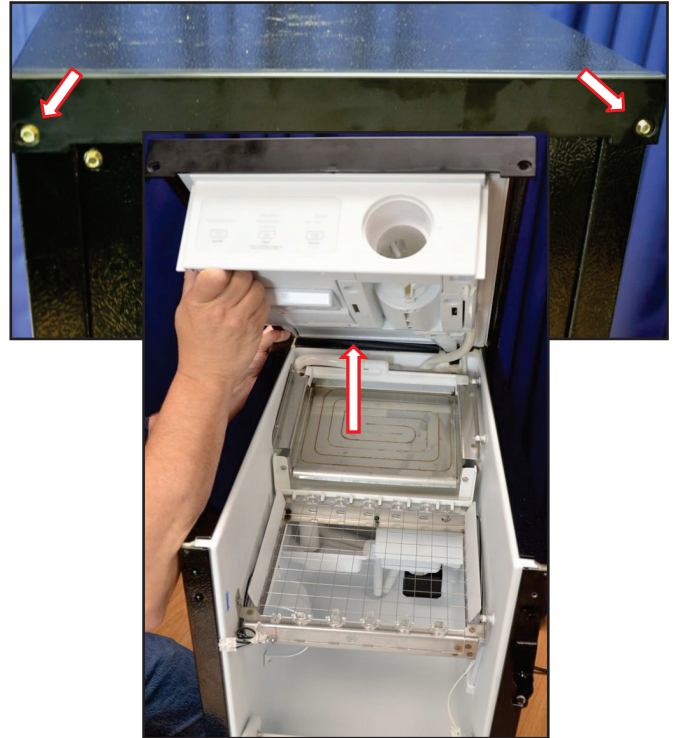

FIGURE 20

4. Unsnap water tube on the reservoir cover. Disconnect the wire harness plugged into the right side of the control housing. See *Figure 21*.

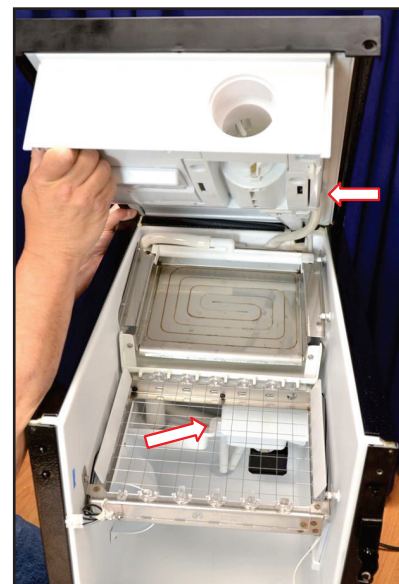

FIGURE 21

COMPONENT ACCESS

Ice Maker Top Components (cont.)

ACCESSING THE CONTROL COMPARTMENT

NOTE: This procedure will prove challenging the first time attempted.

5. 5 hex head screws will need to be removed while supporting the top. Grasp the center of the top with left hand to support top. Screw # 5 needs to be the last to be removed. When the last screw is removed the control housing will separate from the top. See *Figure 22*.

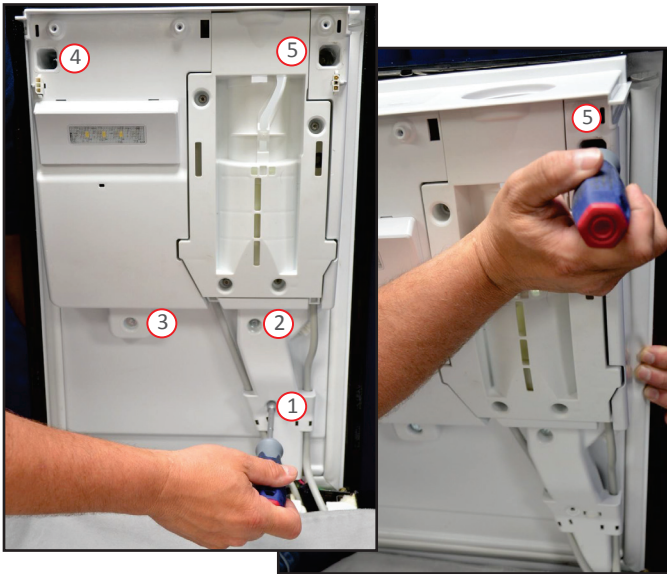

FIGURE 22

6. Lay the control housing on the board and blanket previously positioned. While supporting top remove the ground wire. See *Figure 23*.

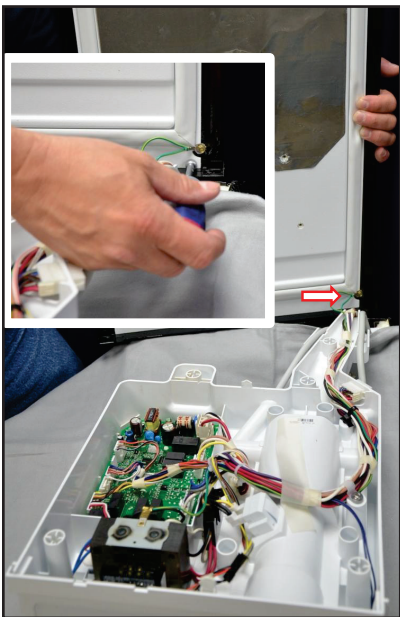

FIGURE 23

REMOVING TRANSFORMER

7. Remove 2 screws and connectors.

NOTE: The transformer doesn't have to be removed to make voltage and resistance checks. See *Figure 24*.

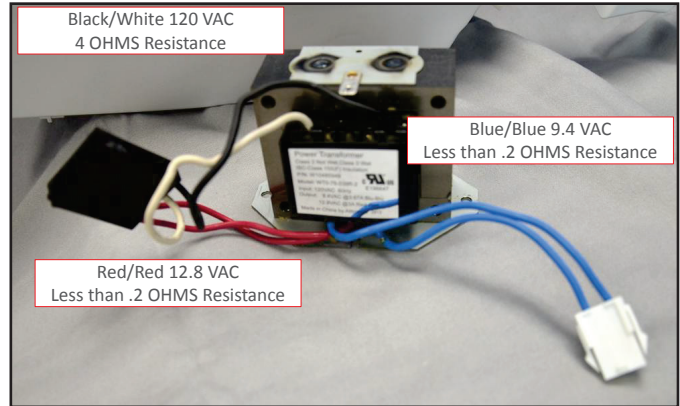

FIGURE 24

REMOVING USER INTERFACE BOARD

8. Release retainers to remove UI board. See *Figure 25*.

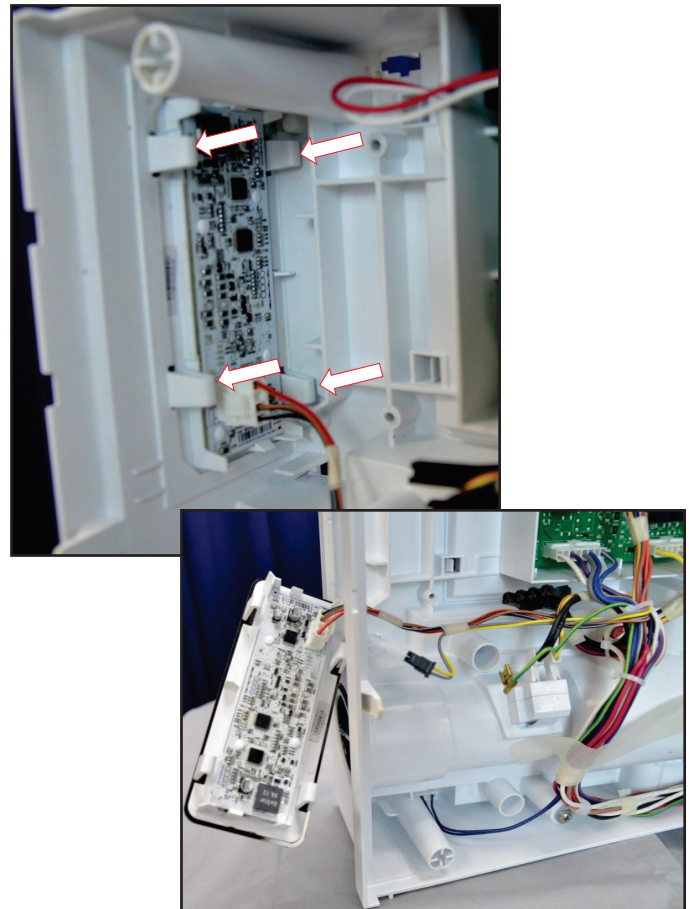

FIGURE 25

Ice Maker Top Components (cont.)

REMOVING MAIN CONTROL BOARD

9. Release retainers to remove main control board.
See *Figure 26*.

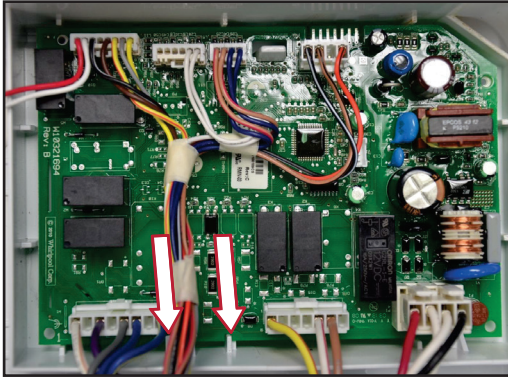



FIGURE 26

Notes

COMPONENT ACCESS

Machine Compartment Components

⚠ WARNING



Electrical Shock Hazard

Disconnect power before servicing.

Replace all parts and panels before operating.

Failure to do so can result in death or electrical shock.

- Compressor terminal cover pops off – instructions on cover. See *Figure 28*.

NOTE: Amperage relay and standard overload (bimetal) are used.

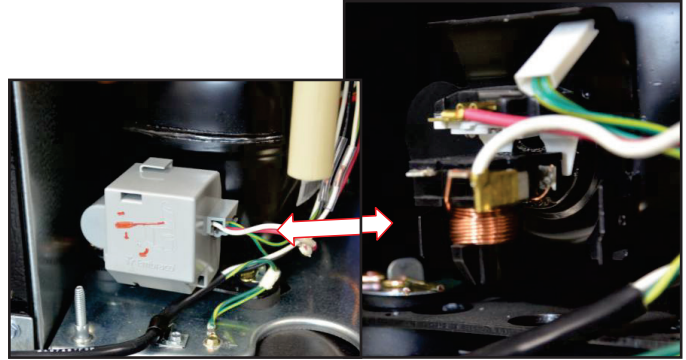

FIGURE 28

FAN INDUCTOR AND THERMISTOR

- Unplug ice maker or disconnect power.
- Remove screws and cover to access machine compartment components. See *Figure 27*.

NOTE: 2 new components on this Ice Maker. An inductor (coil) is wired in series (red wire) with the condenser fan motor. It's purpose in life is to smooth out voltage spikes. The unit Thermistor (2 white wires) signals the control board if the temperature of the machine compartment exceeds 115 F. If it does, then during the next harvest cycle the condenser fan remains on to cool the area. 5 VDC is supplied to the Thermistor. See *Figure 29*.

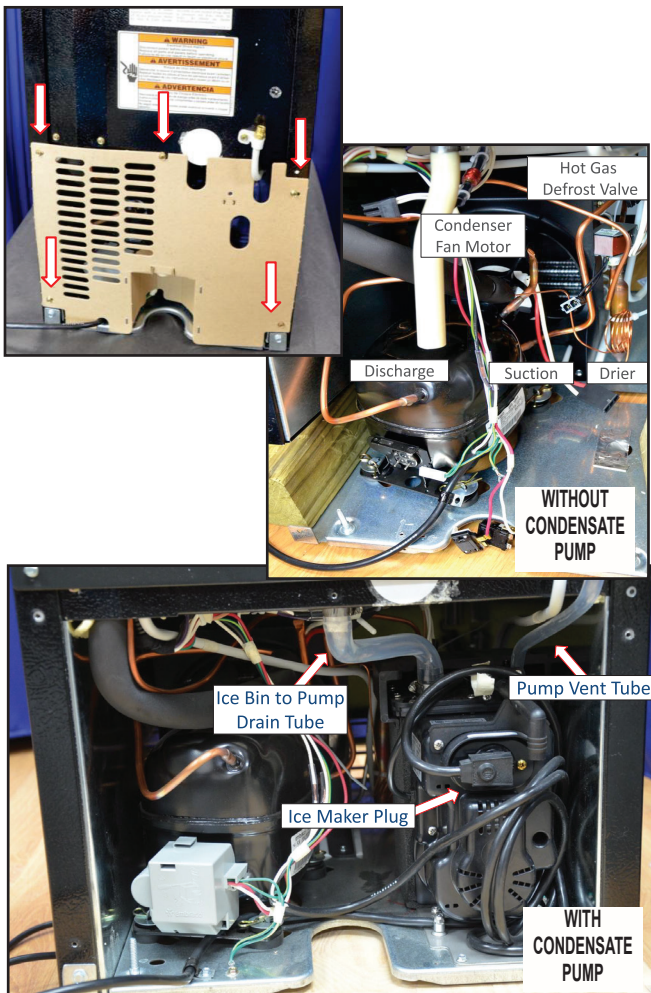

FIGURE 27

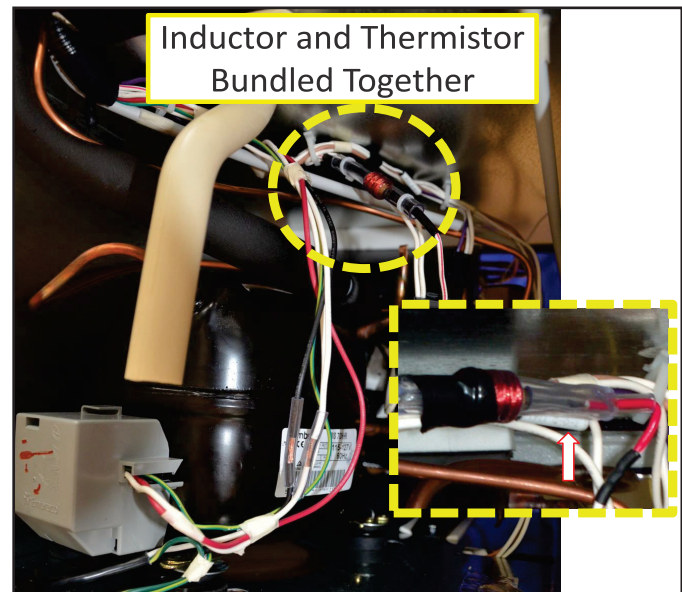

FIGURE 29

Machine Compartment Components (cont.)

CONDENSATE PUMP REMOVAL

1. Unplug ice maker or disconnect power.
2. Remove hose clamp. See *Figure 30*.

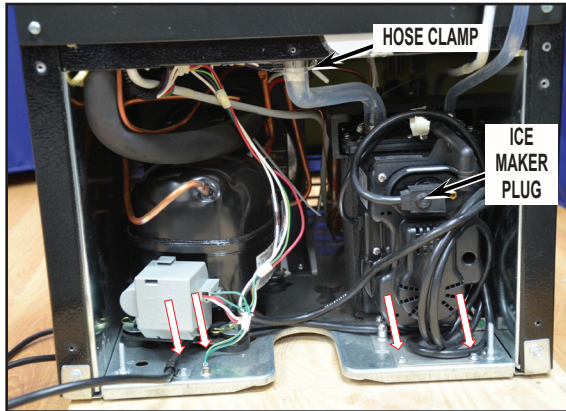

FIGURE 30

3. Unplug the ice maker plug from the condensate pump. See *Figure 30*.
4. Remove 4 screws indicated by arrows. See *Figure 30*.
5. Pull the condensate pump out of the machine compartment. Remove the vent tube hose clamp. See *Figure 31*.

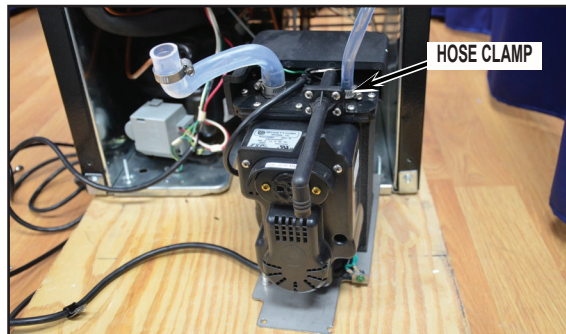

FIGURE 31

RAISING CABINET TO ACCESS COMPONENTS

1. Unplug ice maker or disconnect power.
- NOTE:** To replace compressor, condenser fan motor/blade or hot gas defrost valve raise the cabinet off the base.
2. Remove the 2 base screws. See *Figure 32*.

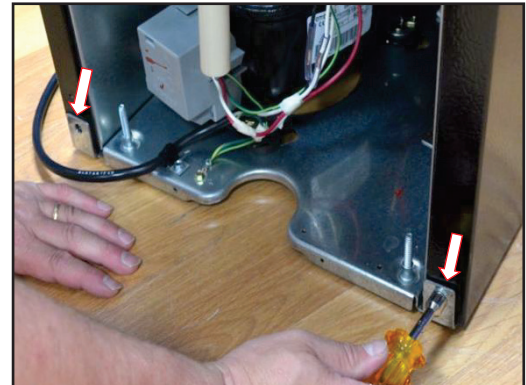

FIGURE 32

3. Remove line cord retainer and chassis ground wire. See *Figure 33*.

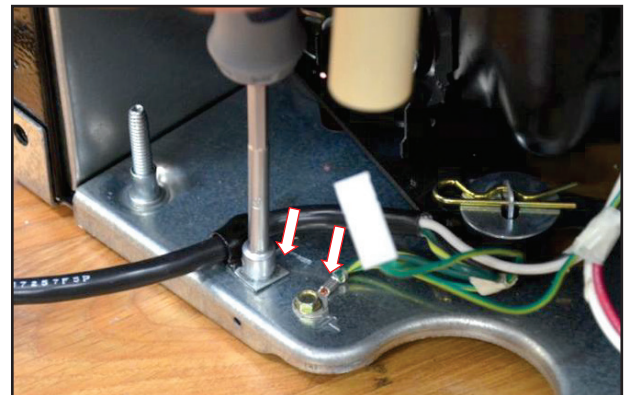

FIGURE 33

COMPONENT ACCESS

Machine Compartment Components (cont.)

4. Tip the cabinet forward and install 4x4" blocks or equivalent to support cabinet. See *Figure 34*.

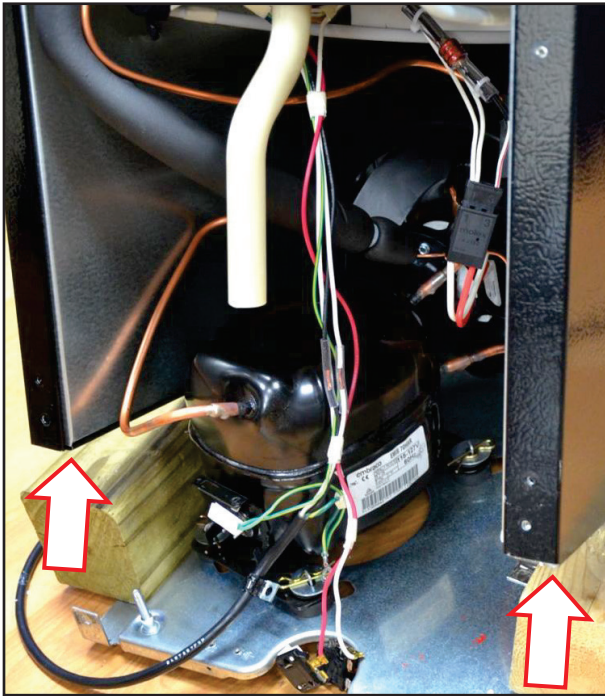

FIGURE 34

Notes

Section 6:



Diagnostics and Troubleshooting



This section contains an example of the Technical Data Sheet that is shipped with the refrigerator.

NOTE: Always refer to the Technical Data Sheet shipped with the refrigerator.

- Safety
- Service Diagnostics
 - Entering Diagnostic Mode
 - Tech Sheet Diagnostic Chart
 - Flush Mode
 - Freeze Cycle
 - Harvest Mode
 - Clean Cycle
- Troubleshooting
 - Compressor Resistances
 - Wiring Schematic
 - Voltage Test Point Chart
 - Locating Test Points in Control Compartment
 - Main Board Connector Identification
 - Evaporator Thermistor
 - Concealed Reed Switch
 - 1901A Pump Kit

Safety

 WARNING

<p>Electrical Shock Hazard Disconnect power before servicing. Replace all parts and panels before operating. Failure to do so can result in death or electrical shock.</p>

 DANGER

<p>Electrical Shock Hazard Only authorized technicians should perform diagnostic voltage measurements. After performing voltage measurements, disconnect power before servicing. Failure to follow these instructions can result in death or electrical shock.</p>

Voltage Measurement Safety Information
<p>When performing live voltage measurements, you must do the following:</p> <ul style="list-style-type: none"><input type="checkbox"/> Verify the controls are in the off position so that the appliance does not start when energized.<input type="checkbox"/> Allow enough space to perform the voltage measurements without obstructions.<input type="checkbox"/> Keep other people a safe distance away from the appliance to prevent potential injury.<input type="checkbox"/> Always use the proper testing equipment.<input type="checkbox"/> After voltage measurements, always disconnect power before servicing.

Service Diagnostics

FOR SERVICE TECHNICIAN'S USE ONLY

⚠️ WARNING



Electrical Shock Hazard
 Disconnect power before servicing.
 Replace all parts and panels before operating.
 Failure to do so can result in death or electrical shock.

⚠️ DANGER



Electrical Shock Hazard
 Only authorized technicians should perform diagnostic voltage measurements.
 After performing voltage measurements, disconnect power before servicing.
 Failure to follow these instructions can result in death or electrical shock.

Voltage Measurement Safety Information

When performing live voltage measurements, you must do the following:

- Verify the controls are in the off position so that the appliance does not start when energized.
- Allow enough space to perform the voltage measurements without obstructions.
- Keep other people a safe distance away from the appliance to prevent potential injury.
- Always use the proper testing equipment.
- After voltage measurements, always disconnect power before servicing.

IMPORTANT: Always used the Technical Data Sheet shipped with the product. The tech sheet information depicted in this Job Aid is an example only.

ENTERING DIAGNOSTIC MODE

Entering and using the diagnostic routine takes a little practice to become familiar with the process.

Utilize watt meter during diagnostics

Make sure to press CLEAN then ON – but not both at same time. Both the Clean and On buttons must be activated together. Press and hold the clean button first and then press and hold the On button.



Turn the product on. Within 20 seconds of Power On, press and hold the Clean button then the ON button together.

DIAGNOSTICS & TROUBLESHOOTING

Service Diagnostics (cont.)

Release both buttons when all user interface LEDs begin to flash

Note: If no button is pressed within 5 seconds then the product goes into the automatic diagnostic mode used at the assembly plant. Each component is cycled for 5 seconds.

The Fast Ice button moves down through each step

Allow a few seconds for unit to register diagnostic mode



To exit manual diagnostics mode, without stepping through all the components, press the On button.

NOTE: After 20 minutes with no key presses, the product exits diagnostic mode and turns off, then starts back to running.



Service Diagnostics (cont.)

TECH SHEET DIAGNOSTIC CHART

Entering and using the diagnostic routine takes a little practice to become familiar with the process.

Step	Max Time	Component	On/Off LED	Clean LED	MAX ICE LED	CLEANING COMPLETE
1	5 sec	Entry into Test Mode(All LED'S turn ON)		ALL LED'S ON		
2		Bin Thermistor	ON Solid=OK 2 Blinks=Open 4 Blinks=Short	OFF	OFF	OFF
3		Evaporator Thermistor	OFF	ON Solid=OK 2 Blinks=Open 4 Blinks=Short	OFF	OFF
4		Unit Thermistor	OFF	OFF	ON Solid=OK 2 Blinks=Open 4 Blinks=Short	OFF
5	1 min	Water valve turns On until water is detected by touch sensor or max time is reached.	OFF	ON	On solid = reservoir full Blinking = reservoir empty	OFF
6		Recirculation Pump	ON	ON	ON	OFF
7		Reservoir Drain Pump	ON	OFF	OFF	OFF
8		Compressor and Condenser Fan Motor	ON Solid while cooling	ON Solid while cooling	Off while cooling, evap therm > 4.5°F Blinking when evap thermistor <= 4.5°F .full frost pattern should be visible	OFF
9		Compressor and Hot Gas Valve	ON Solid while heating	ON Solid while heating	On solid while heating, evap therm < 12°F Blinking when evap thermistor >= 12°F	OFF
10		Ice Thickness	OFF	OFF	2 Blinks = Thin 4 Blinks = Normal 6 Blinks = Thick Press Clean button to cycle between settings.	OFF
11*		UI software version	Blinks = numeric value for Major	Blinks = numeric value for Minor	Blinks = numeric value for test	OFF
12*		ACU Software version	Blinks = numeric value for Major	Blinks = numeric value for Minor	Blinks = numeric value for test	ON

* Steps 11 & 12 are for manufacturing use only.

DIAGNOSTICS & TROUBLESHOOTING

Service Diagnostics (cont.)

FLUSH MODE

Tech sheet will incorporate strip circuits showing the sequence of events, time of each event and the energized circuits.

Flush Mode – Cycles once every time the unit is turned on.

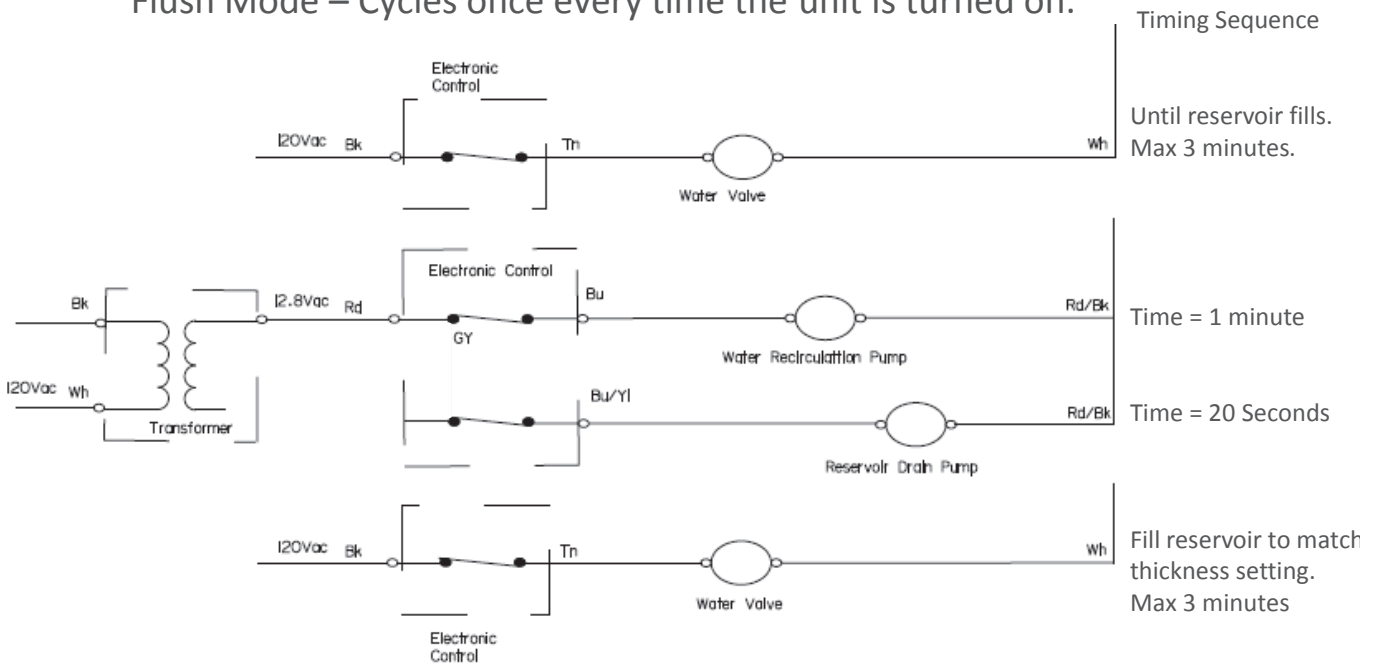

FREEZE CYCLE

The freeze cycle normally takes 25-35 minutes depending on ambient conditions and thickness setting

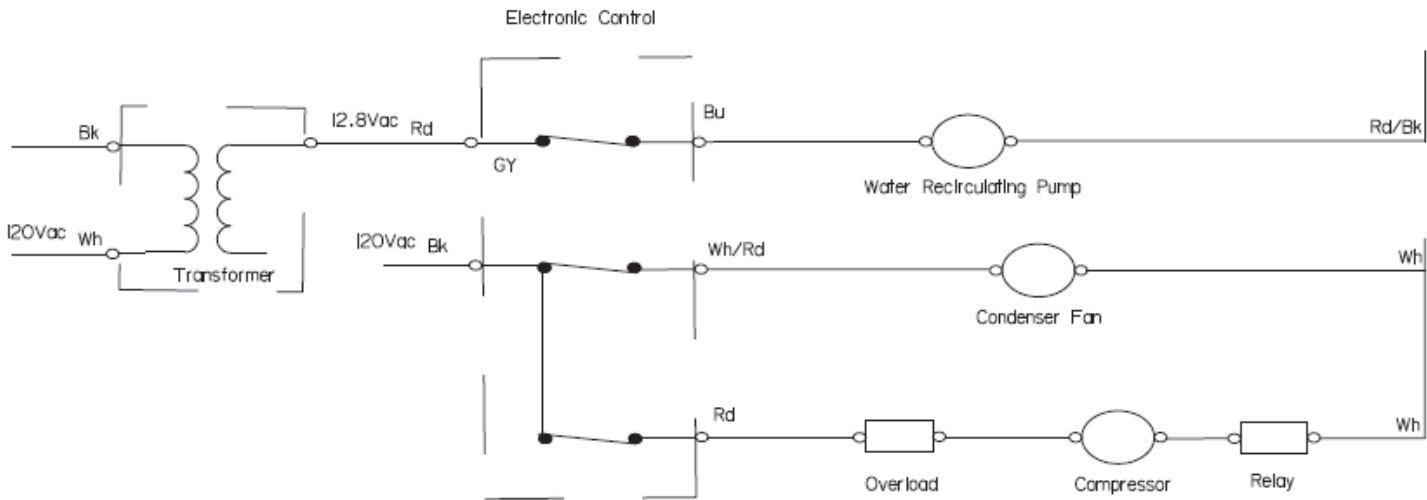

Freeze Cycle Under Normal Conditions Is 25 To 35 Minutes

Service Diagnostics (cont.)

HARVEST MODE

The length of the harvest cycle takes varies - Maximum time is 16 minutes

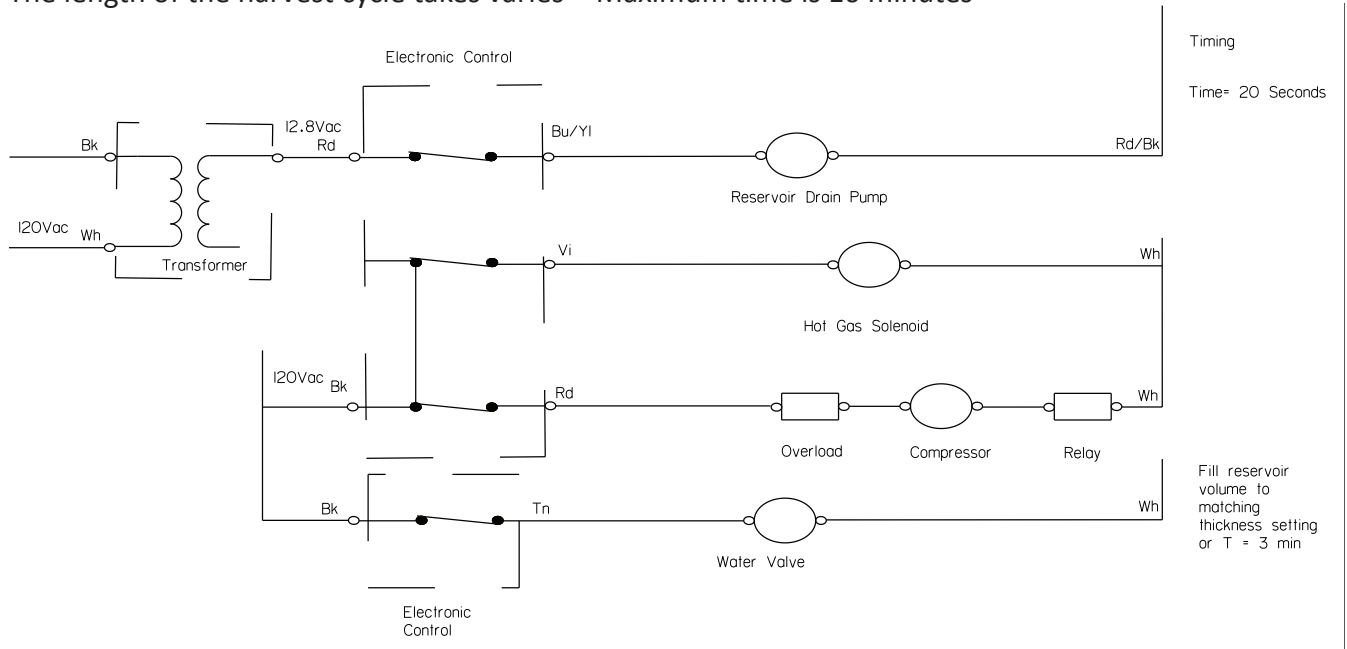

CLEAN CYCLE

The clean cycle sequence chart – emphasize that hard water necessitates frequent cleaning. Technicians should emphasize the need for scheduled cleaning of the unit to prevent mineral build up causing hanging slabs of ice.

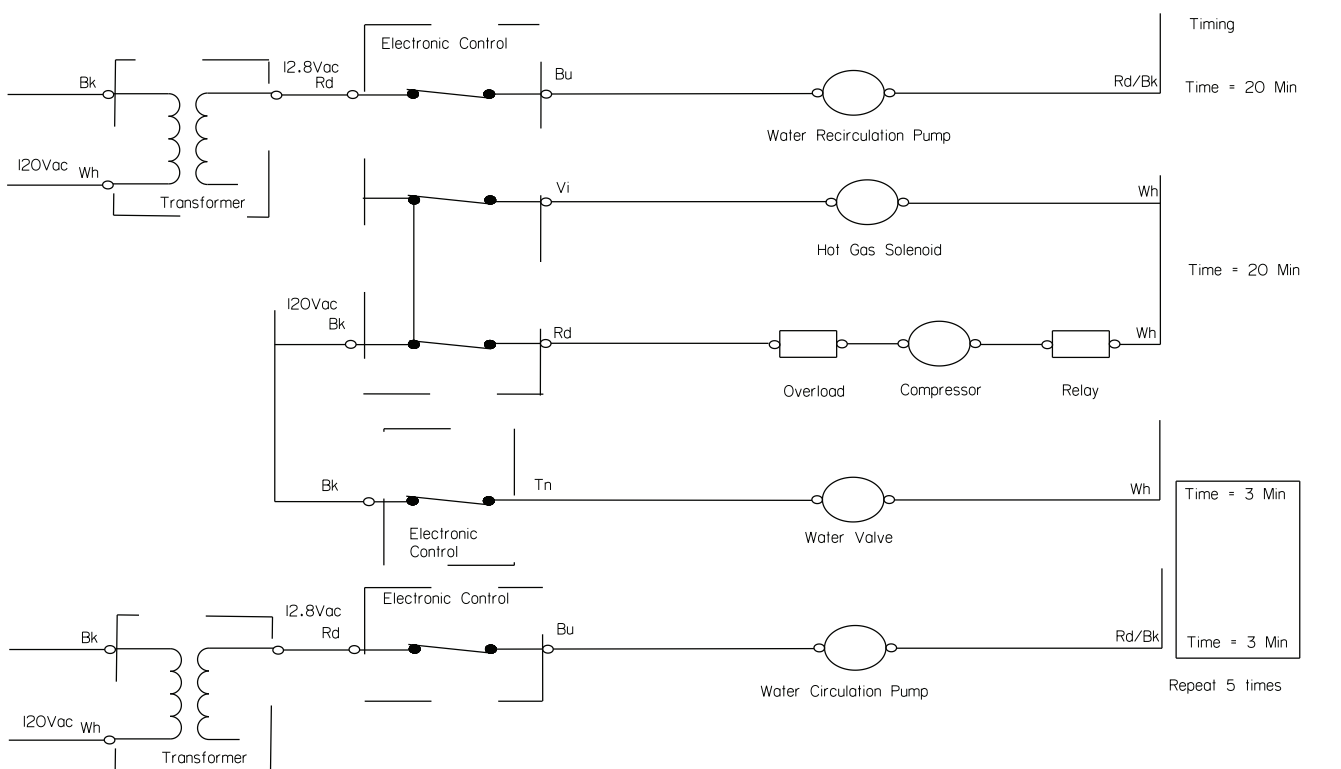

Troubleshooting

COMPRESSOR RESISTANCES

1. Unplug ice maker or disconnect power.

NOTE: This is one of the few remaining applications of a split phase motor.

Run winding – approximately 3 OHMS



Start Winding - approximately 7 OHMS

Overload (bimetal) – near zero

Amperage relay coil - near zero

Amperage relay L to S – Infinite with relay in upright position – near zero with the relay turned upside down.

 WARNING

<p>Electrical Shock Hazard Disconnect power before servicing. Replace all parts and panels before operating. Failure to do so can result in death or electrical shock.</p>

 DANGER

<p>Electrical Shock Hazard Only authorized technicians should perform diagnostic voltage measurements. After performing voltage measurements, disconnect power before servicing. Failure to follow these instructions can result in death or electrical shock.</p>

<p>Voltage Measurement Safety Information</p> <p>When performing live voltage measurements, you must do the following:</p> <ul style="list-style-type: none"><input type="checkbox"/> Verify the controls are in the off position so that the appliance does not start when energized.<input type="checkbox"/> Allow enough space to perform the voltage measurements without obstructions.<input type="checkbox"/> Keep other people a safe distance away from the appliance to prevent potential injury.<input type="checkbox"/> Always use the proper testing equipment.<input type="checkbox"/> After voltage measurements, always disconnect power before servicing.
--

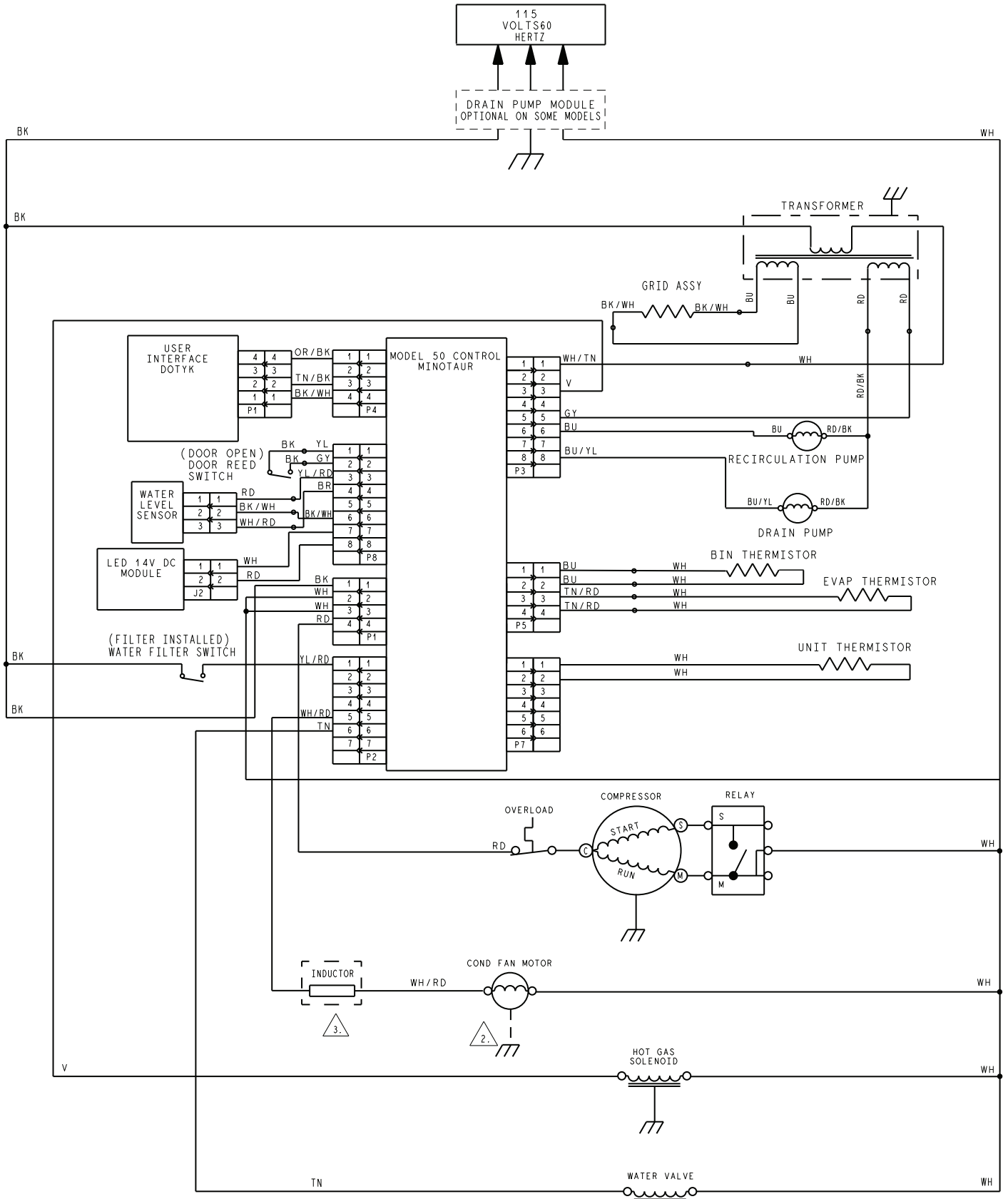
Troubleshooting (cont.)

WIRING SCHEMATIC



DIAGNOSTICS & TROUBLESHOOTING

Troubleshooting (cont.)

VOLTAGE TEST POINT CHART

VOLTAGE TEST POINTS - MINOTAUR CONTROL BOARD						
	FROM	COLOR	TO	COLOR	CONDITIONS	
MAIN CONTROL	P1	P1-1	BK	P1-2	WH	120VAC INPUT- CONSTANT WHEN PLUGGED IN
		P1-4	RD	P1-2	WH	120VAC OUTPUT TO COMPRESSOR
	P2	P2-1	YL/RD	P1-2	WH	120VAC INPUT- WATER FILTER SWITCH FEEDBACK
		P2-5	WH/RD	P1-2	WH	120VAC OUTPUT TO CONDENSER FAN
		P2-6	TN	P1-2	WH	120VAC OUTPUT TO WATER VALVE
	P3	P3-1	WH/TN	P1-1	BK	120VAC NEUTRAL FOR TRANSFORMER
		P3-3	V	P1-2	WH	120VAC OUTPUT TO HOT GAS VALVE
		P3-5	GY	4CKT PIN2	RD/BK	12.8 VAC INPUT FROM TRANSFORMER
		P3-6	BU	4CKT PIN2	RD/BK	12.8 VAC OUPUT TO RECIRCULATING PUMP
		P3-8	BU/YL	4CKT PIN2	RD/BK	12.8 VAC OUPUT TO DRAIN PUMP
	P4	P4-1	OR/BK	P4-4	BK/WH	14 VDC OUTPUT TO USER INTERFACE
		P4-3	TN/BK	P4-4	BK/WH	COMMUNICATION
	P5	P5-1	BU	P5-2	BU	BIN Thermistor 1 to 4 VDC*
		P5-3	TN/RD	P5-4	TN/RD	EVAP Thermistor 1 to 4 VDC*
	P7	P7-1	WH	P7-2	WH	Unit Thermistor 1 to 4 VDC*
	P8	P8-1	YL	P8-2	GY	5VDC Reed Switch
		P8-3	YL/RD	P8-4	BR	5VDC INPUT Water Level Switch - When Water Present
		P8-6	BK/WH	P8-4	BR	14 VDC OUTPUT TO WATER LEVEL SENSOR
P8-7		WH	P8-8	RD	14 VDC OUTPUT TO DIAMOND LED LIGHT	
VOLTAGE TEST POINTS - DOTYK USER INTERFACE BOARD						
J1	J1-4	OR/BK	J1-1	BK/WH	14 VDC INPUT TO UI	
	J1-2	TN/BK	J1-1	BK/WH	COMMUNICATION	
VOLTAGE TEST POINTS - DIAMOND LED						
J2	J2-1	WH	J2-2	RD	14 VDC TO DIAMOND LED LIGHT	
VOLTAGE TEST POINTS - TRANSFORMERS						
TRAN	4CKT PIN3	WH	4CKT PIN4	BK	120 VAC INPUT TO TRANSFORMER	
	4CKT PIN1	RD	4CKT PIN2	RD	12.8 VAC OUTPUT FROM TRANSFORMER	
	3CKT PIN1	BU	3CKT PIN3	BU	9.4 VAC OUTPUT FROM TRANSFORMER	

* Voltage varies with Thermistor resistance (5 VDC Output with Thermistor unplugged)

Troubleshooting (cont.)

LOCATING TEST POINTS IN CONTROL COMPARTMENT

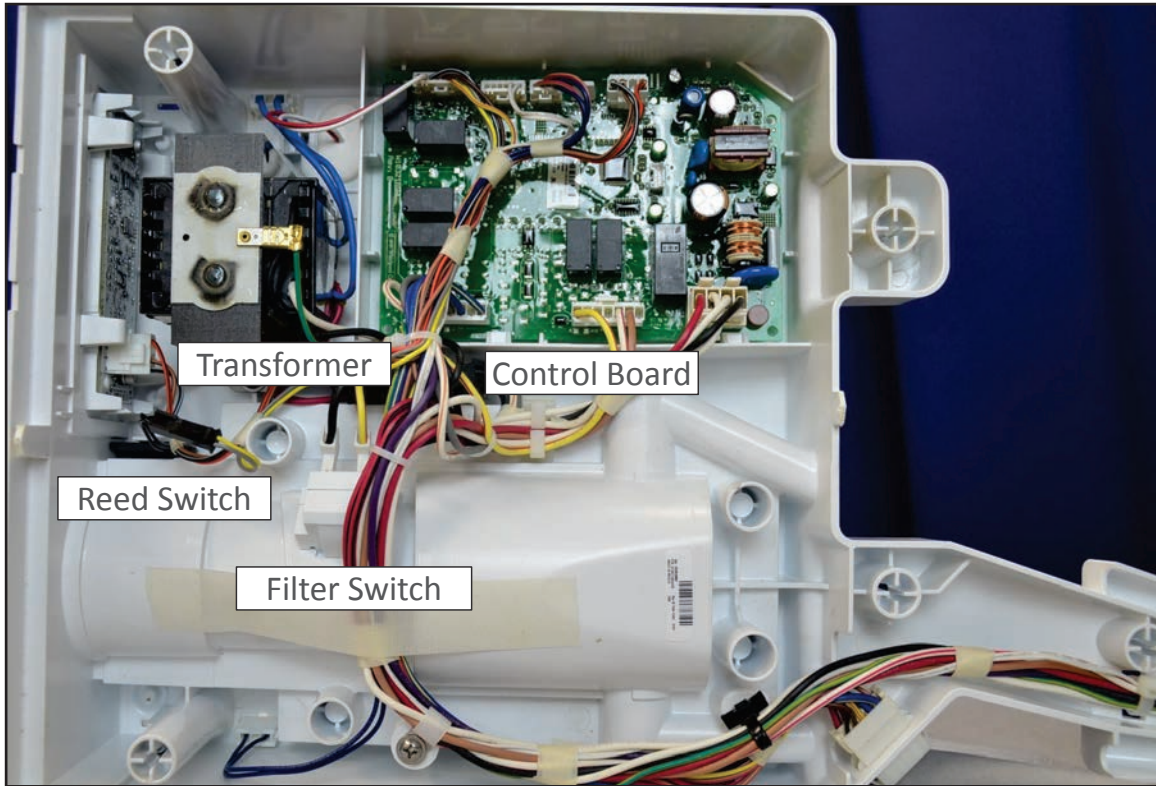

MAIN BOARD CONNECTOR IDENTIFICATION

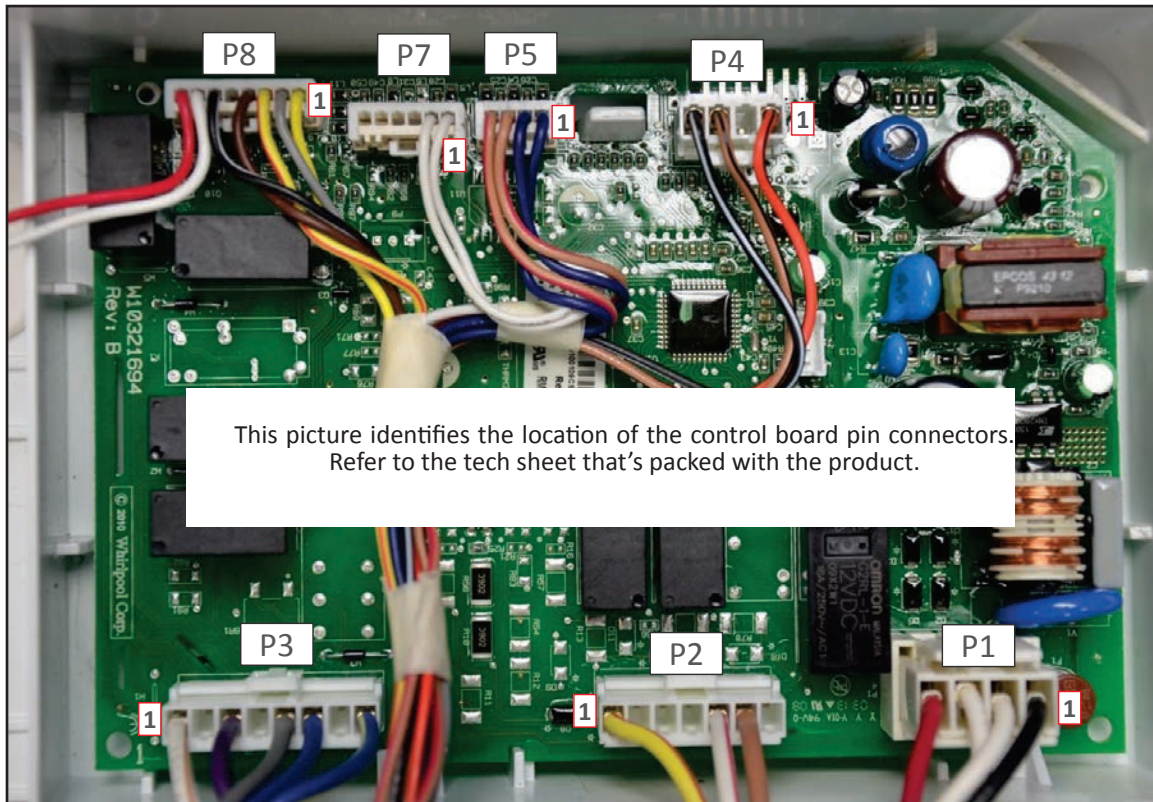

DIAGNOSTICS & TROUBLESHOOTING

Troubleshooting (cont.)

EVAPORATOR THERMISTOR

The start of a harvest begins when the water is below the touch sensor sensing level or a max time of 25 min. The evap. thermistor is only used to end a harvest cycle.

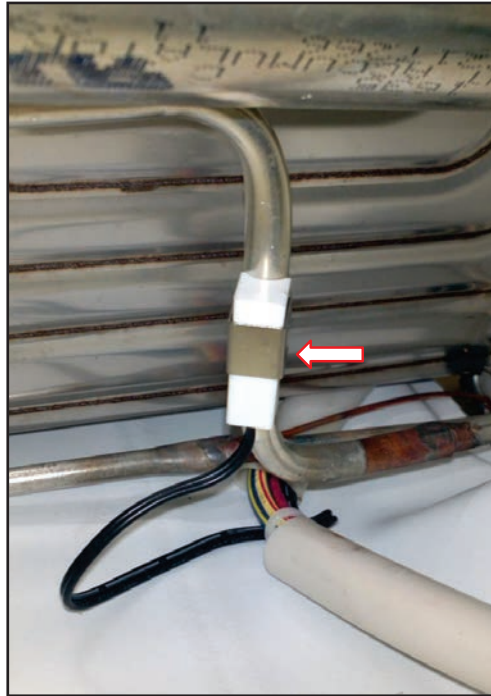

CONCEALED REED SWITCH

A strong magnet can be used to actuate the reed switch.
Another option is - if the control compartment has been accessed, a resistance check can be made.
Door closed near zero OHMS resistance.



Troubleshooting (cont.)

1901A PUMP KIT

A large percentage of service calls can be attributed to pump installation mistakes.

Installing the pump is relatively easy as long as the installer uses the components included in the kit and make no substitutions or try to reuse old components.

Follow the instruction sheet and DO NOT substitute drain hose. Use the corrugated hose only.

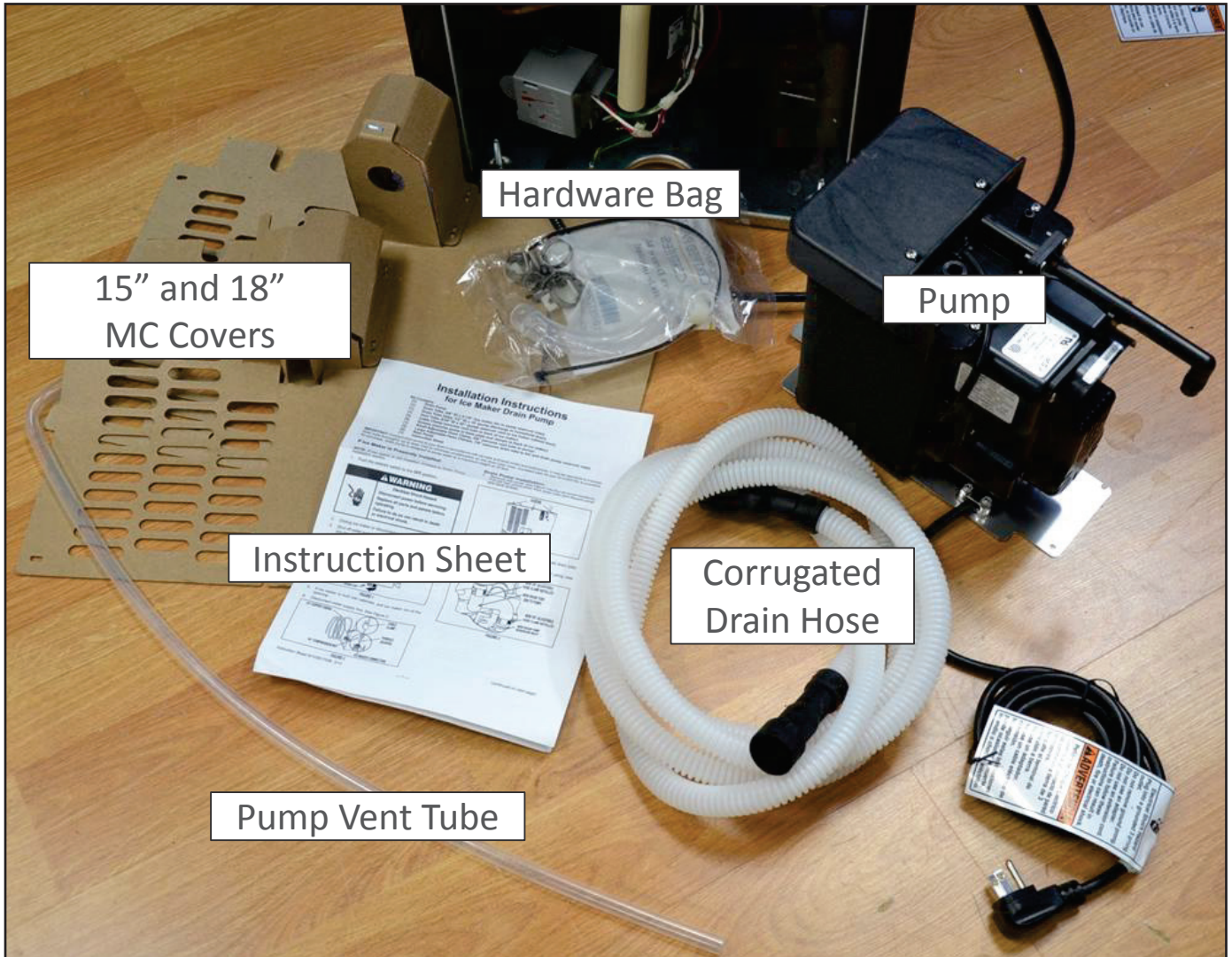

Section 7: Refrigerant Recovery and Charging Procedures

This section provides service parts access, removal and Installation information concerning KitchenAid, Maytag and Whirlpool dual evaporator French Door Refrigerators.

- Representative Examples of Equipment, Tools and Supplies
- Equipment, Tools and Supplies
- Key Components
- Phase One: Initial Hook Up
- Phase Two: Refrigerant Recovery
- Phase Three: Make Repairs
- Phase Four: Evacuation
- Phase Five: Charging

Sealed System Repair

 WARNING

<p>Electrical Shock Hazard Disconnect power before servicing. Replace all parts and panels before operating. Failure to do so can result in death or electrical shock.</p>

Sealed System Repair (cont.)

Representative Examples of Equipment, Tools and Supplies:



Equipment, Tools and Supplies:

- Recovery pump
- 134A Recovery Cylinder
- Non Dry Drier
- Schrader Valve Extractor and Extra Valves
- Tubing cutters
- Process tube with schrader valve
- 4 port manifold gauge set
- Sandpaper
- Charging hoses
- Micron Vacuum Gauge and Copper "T fitting for Micron gauge
- 1/4" and 5/16" Swedges
- 4 Hand valves
- Brazing alloy and Flux
- Acetylene torch
- Welding/Brazing blanket
- Fire Extinguisher
- Heated charging cylinder
- 1/2" wrench, 7/16" wrench, Pliers, Triangle File and Assorted hand Tools
- Temporary access Valves
- High Capacity dual stage Vacuum pump (4 cf. or greater)
- PPE - Personal Protection Equipment - Approved Eye Protection
- 134A Heated Charging Cylinder and Charging Hose or Electronic Refrigerant Scale
- VOM Multimeter and Clamp On Ammeter
- Tubing Cutters
- Heat Gun
- Non Dye Drier with Schrader Valve
- Extension Tube with Schrader Valve (For insertion into process tube)
- Shut Off hand Valves

REFRIGERANT RECOVERY AND CHARGING PROCEDURES

Sealed System Repair (cont.)

Key Components

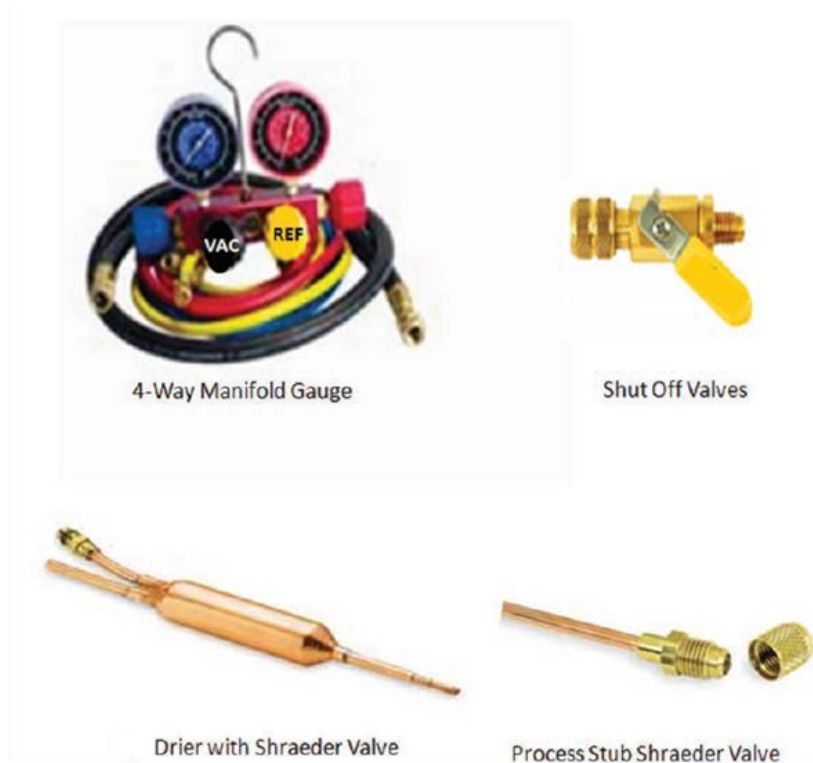

Note: When handling refrigerant, ANSI certified Personal Eye Protection is recommended.

Note: Always follow the Manufactures' instructions shipped with tools and Equipment .

Equipment, Tools and Supplies:

Everything depicted in this process is currently used in the refrigeration industry. If you already perform sealed system repairs you may have some or all of these items . If not, this equipment is readily available from most refrigeration supply houses.

Note: There are a number of different manufactures of this equipment. Whirlpool is not endorsing specific brands.

Key Components

The key components used in this process are:

The 4 way manifold gauge set

Shut off valves

Non Dye Drier with schrader valve

Process stub extension with schrader valve

These items are critical for accurate charging and efficiency.

Sealed System Repair (cont.)

Phase One: Initial Hook Up

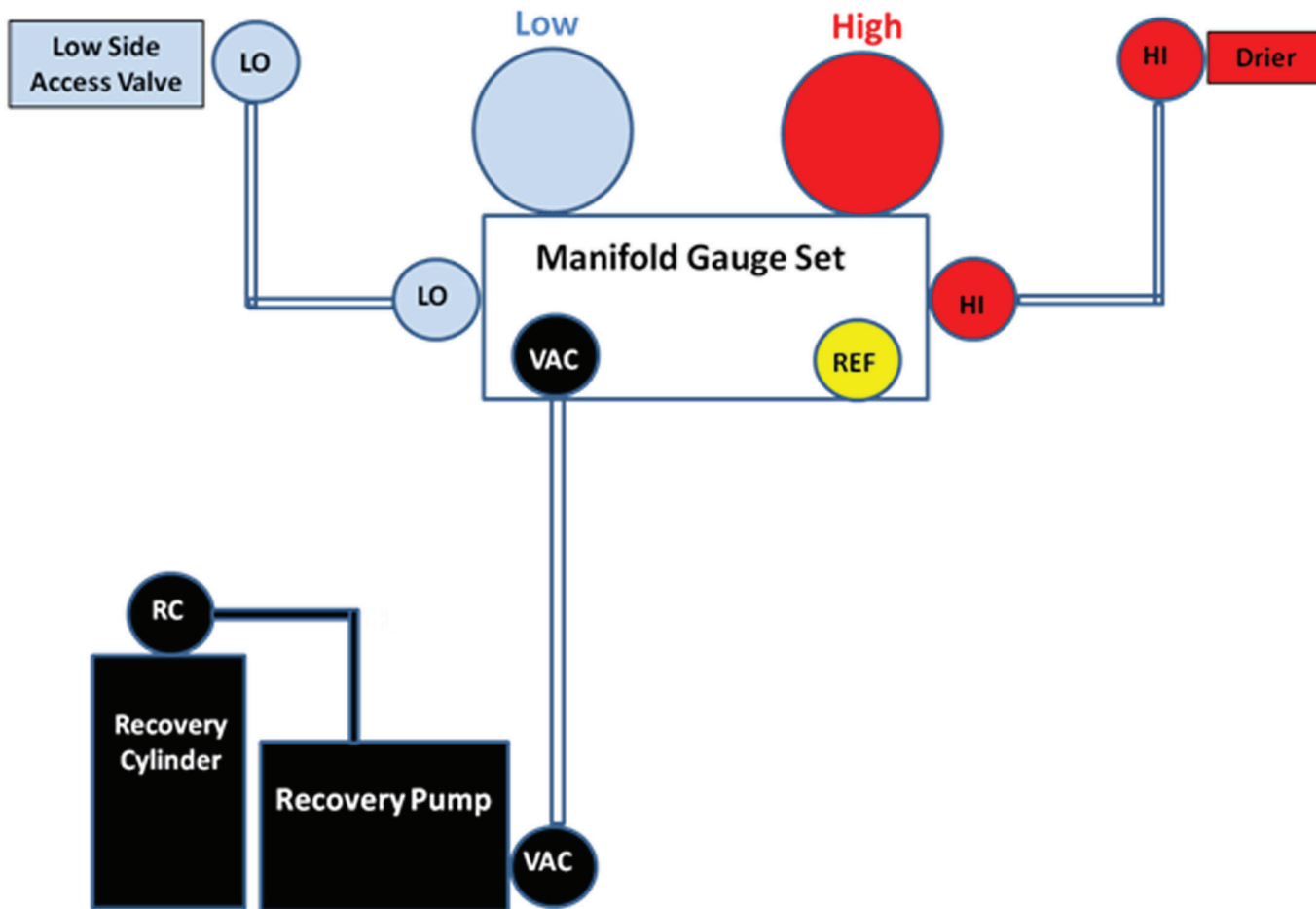

Sealed System Repair (cont.)

Phase One: Initial Hook Up

1. Verify Failure
2. (For dual evaporator products) Enter the refrigerator diagnostic service mode and advance to step 4 to insure the 3-way is open to both RC and FC capillary tubes
3. Unplug or disconnect power to refrigerator
4. Remove the machine compartment cover
5. Install High and Low side temporary access valves
6. Install shut off valves on access valves
7. Connect high side manifold gauge hose to high side shut off valve
8. Connect low side manifold gauge hose to low side shut off valve
9. Connect evacuation hose to recovery pump inlet hand valve
10. Connect hose from recovery pump outlet valve to recovery cylinder hand valve

Sealed System Repair (cont.)

Phase Two: Refrigerant Recovery

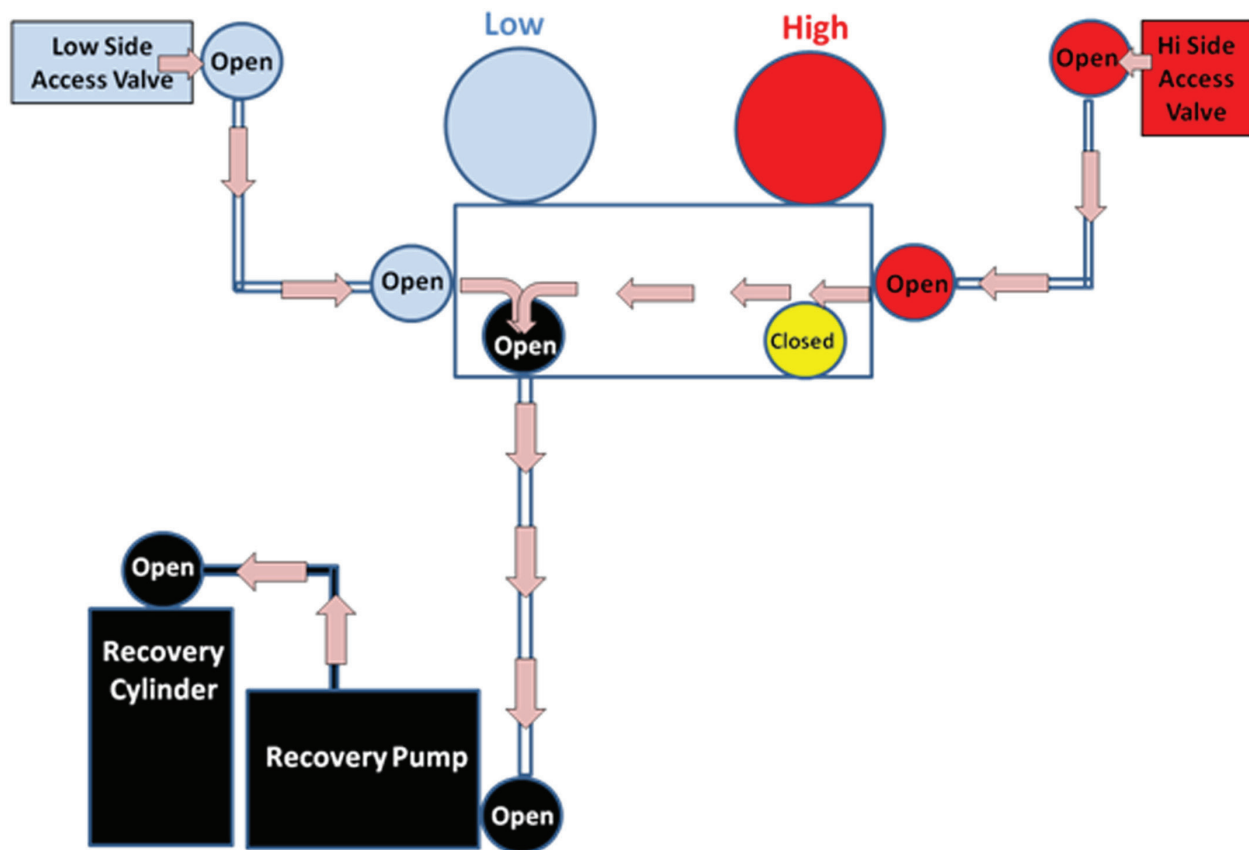

1. Start recovery pump
2. Open recovery pump inlet valve
3. Open recovery pump outlet valve
4. Open inlet valve on recovery cylinder
5. Open evacuation manifold valve
6. Open low side manifold valve
7. Open high side manifold valve
8. Open high side shut off valve
9. Open Low side shut off valve
10. Recover refrigerant from both the high and low side of the system
11. When the gauges indicate a 4" HG system vacuum has been achieved, close the recovery cylinder hand valve and shut off the recovery pump
12. Remove the high and low side hoses and shut off valves from the access valves and attach to the manifold ports

Sealed System Repair (cont.)

Phase Three: Make Repairs

1. Remove temporary access valves
2. Remove any wiring harnesses, starting components, water tubes or related components that could be damaged during repair
3. Install heat shields to protect the ice maker cabinet and adjacent components before brazing
4. Make necessary repairs
5. Remove schrader valve from drier and install drier
6. Remove schrader valve from the process stub extension tube and install (or braze on saddle valve on suction line and install)
7. After brazing is completed install the schrader valves

Sealed System Repair (cont.)

Phase Four: Evacuation

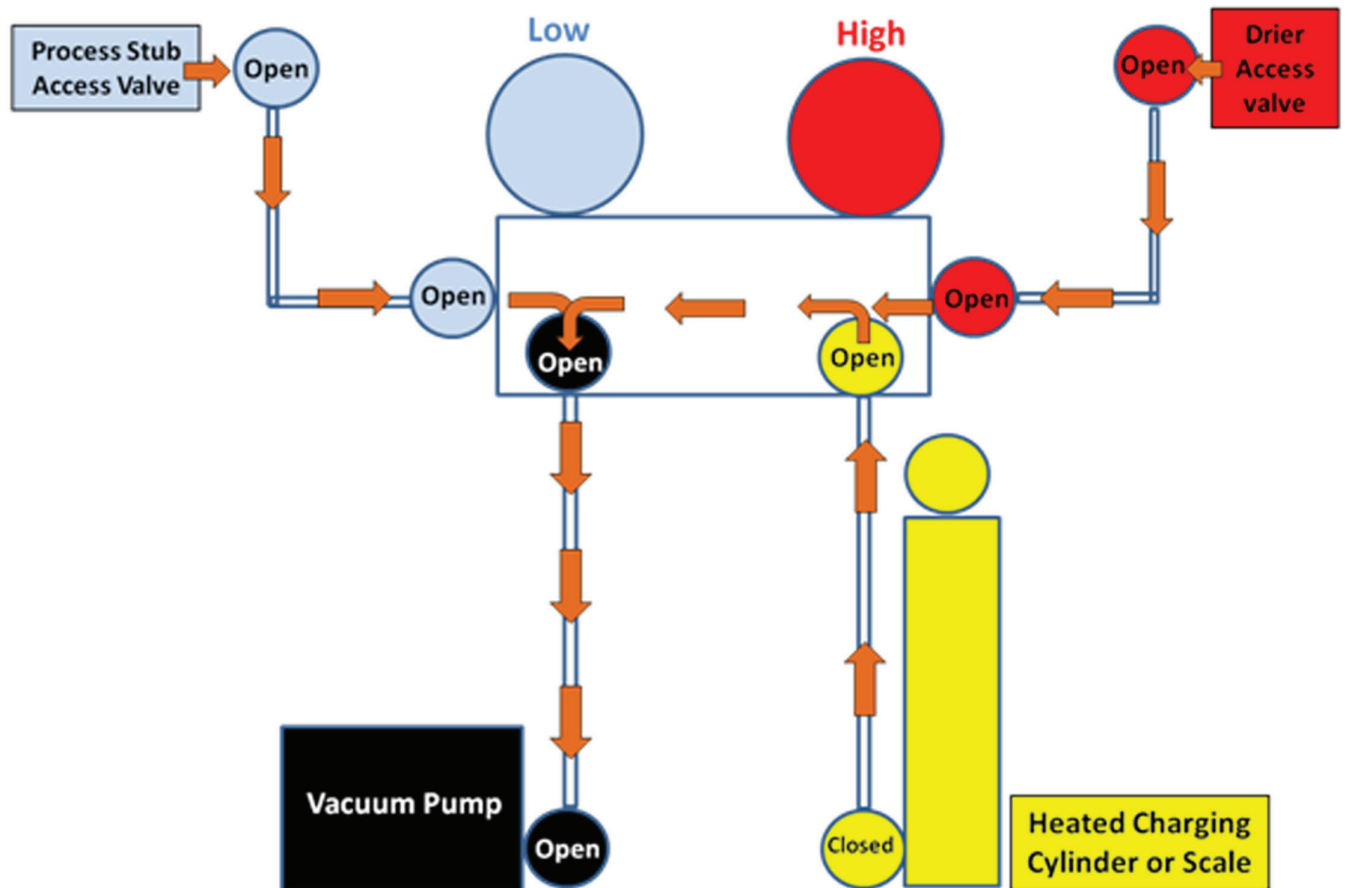

1. Connect high and low side manifold hoses to the drier and process tube shut off valves
2. Connect a hose from evacuation manifold gauge valve to the inlet of the vacuum pump
3. Fill the charging cylinder with an additional ounce of R134A than is listed on the model number plate and plug in the cylinder. Heat the refrigerant until the pressure is 30# higher than the equivalent ambient pressure would be.
4. Connect a hose from the charging cylinder to the Refrigerant port on the manifold
5. Close all valves
6. Start the vacuum pump
7. Open the inlet valve on the vacuum pump
8. Open the VAC valve on the manifold
9. Open the REF valve on the manifold

REFRIGERANT RECOVERY AND CHARGING PROCEDURES

Sealed System Repair (cont.)

Phase Four: Evacuation (continued)

10. Open the high side manifold valve
11. Open the high side shut off valve
12. Open the low side manifold valve
13. Open the low side shut off valve
14. Evacuate from both the high and low side of the system

Note: If the evaporator is cold open the door and allow to warm or use a heat gun to heat the evaporator

Maintain 28" HG vacuum for 5 minutes

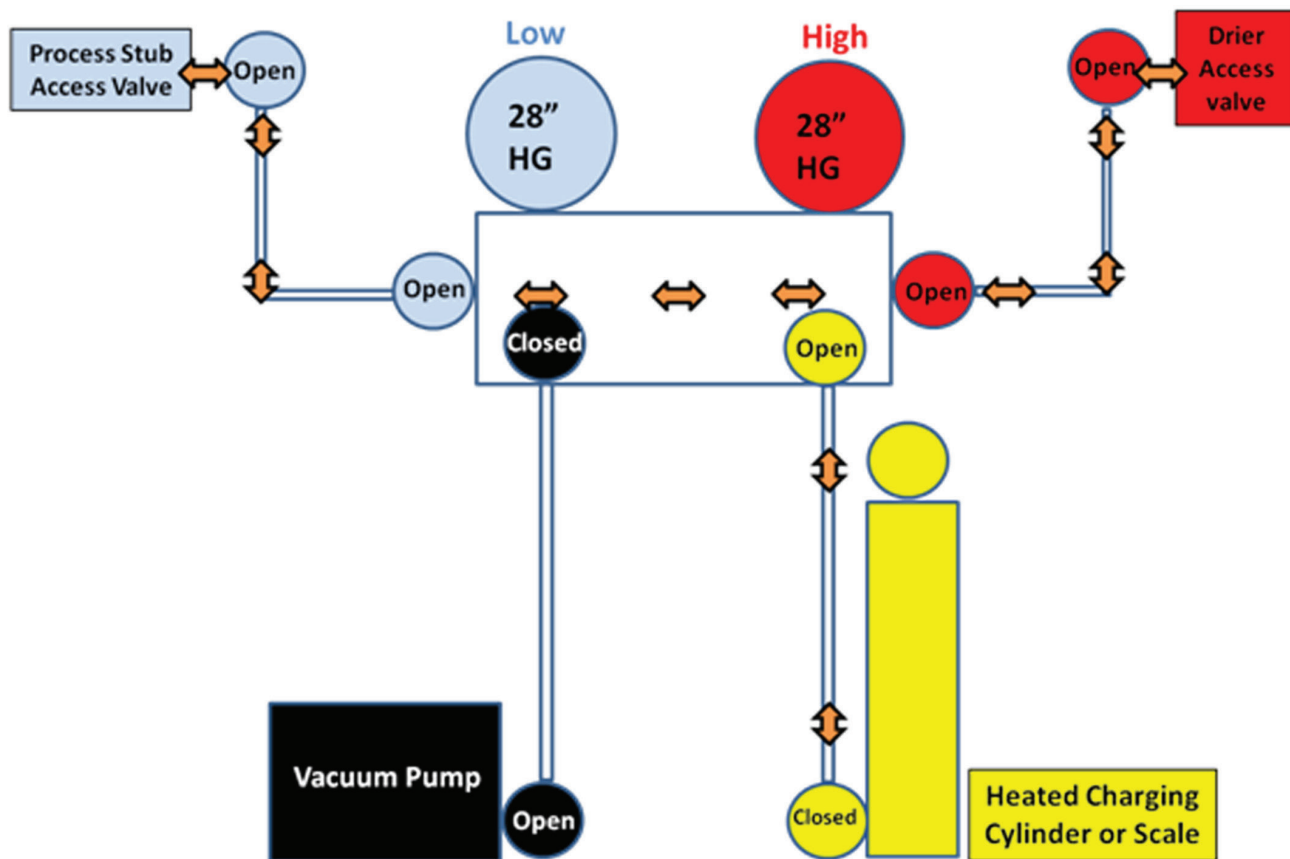

15. Evacuate the system until the pressure drops to a minimum of 28" HG.
16. Close the VAC valve
17. The 28" HG vacuum should remain constant – any increase in pressure indicates moisture in the system or a system or equipment leak
18. If the vacuum remains at a minimum of 28" HG for 5 minutes proceed to the charging phase

Sealed System Repair (cont.)

Phase Five: Charging

1. Set the barrel on the charging cylinder to align with the refrigerant pressure
2. Subtract the refrigerant system charge from the amount of refrigerant in the cylinder and mark the level using a rubber band on the barrel
3. Open the charging cylinder hand valve and dump in the refrigerant into both the high and low side of the system. Stop when the exact charge has been added.

Removing refrigerant from hoses

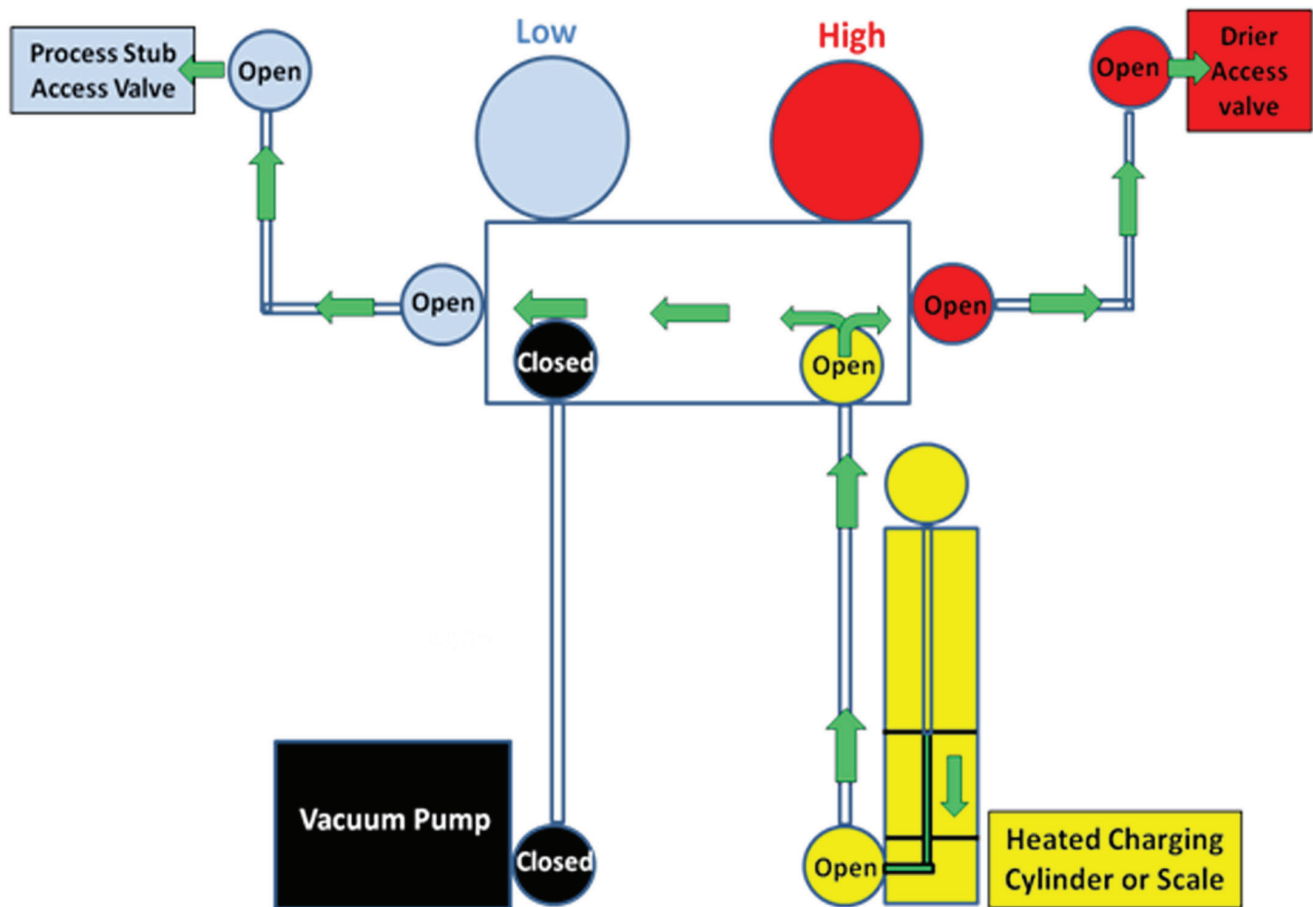

Sealed System Repair (cont.)

Phase Five: Charging (continued)

Phase Five: Evacuation , Leak Checking and Return to Service

4. Close the high side shut off hand valve connected to the drier and the low side shut off hand valve
5. Plug in the refrigerator and start the compressor and let the compressor run for 1 minute
6. Crack open the low side shut off valve and remove all the refrigerant remaining in the hoses
7. When the low side pressure drops to "0" shut off:
REF valve on manifold
High side valve on manifold
Low side valve on manifold
Low side shut off hand valve
8. Unplug the refrigerator and remove the high and low side shut off valves
9. Install silicone tape to shraeder valve threads and install caps.
10. Wait a minimum of 2 minutes and use soap bubble solution to check all high side connections first and then check the low side connections.
11. Plug in the refrigerator and start the compressor
12. The system is fully charged and will begin cooling. Check for heat at the compressor discharge line and then the heat loop. Check for cool air from the evaporator
13. Once it has been determined the unit is cooling unplug the refrigerator.
14. Install all machine compartment components and the cover
15. Plug in the refrigerator and set temperature
16. Instruct customer

NOTES

PRODUCT SPECIFICATIONS & WARRANTY INFORMATION SOURCES

IN THE UNITED STATES:

FOR PRODUCT SPECIFICATIONS AND WARRANTY INFORMATION CALL:

FOR WHIRLPOOL PRODUCTS:	1-800-253-1301
FOR KITCHENAID PRODUCTS:	1-800-422-1230
FOR ROPER PRODUCTS:	1-800-447-6737

FOR TECHNICAL ASSISTANCE WHILE AT THE CUSTOMER'S HOME CALL:

THE TECHNICAL ASSISTANCE LINE: 1-800-832-7174

**HAVE YOUR STORE NUMBER READY TO IDENTIFY YOU AS AN
AUTHORIZED IN-HOME SERVICE PROFESSIONAL**

FOR LITERATURE ORDERS:

PHONE: 1-800-851-4605

FOR TECHNICAL INFORMATION AND SERVICE POINTERS:

www.servicematters.com

IN CANADA:

FOR PRODUCT SPECIFICATIONS AND WARRANTY INFORMATION CALL

1-800-461-5681

FOR TECHNICAL ASSISTANCE WHILE AT THE CUSTOMER'S HOME CALL:

THE TECHNICAL ASSISTANCE LINE: 1-800-488-4791

**HAVE YOUR STORE NUMBER READY TO IDENTIFY YOU AS AN
AUTHORIZED IN-HOME SERVICE PROFESSIONAL**

