

Whirlpool®

SERVICE MANUAL

**WHIRLPOOL & MAYTAG
27" FRONT-LOAD WASHERS**



FORWARD

This Whirlpool Service Manual, (Part No. W11169652B), provides the In-Home Service Professional with service information for the “WHIRLPOOL & MAYTAG 27” FRONT-LOAD WASHERS.”

The Wiring Diagram used in this Service Manual is typical and should be used for training purposes only. Always use the Wiring Diagram supplied with the product when servicing the washer.

For specific operating and installation information on the model being serviced, refer to the “Use and Care Guide” or “Installation Instructions” provided with the washer.

GOALS AND OBJECTIVES

The goal of this Service Manual is to provide information that will enable the In-Home Service Professional to properly diagnose malfunctions and repair the “WHIRLPOOL & MAYTAG FRONT-LOAD WASHERS.”

The objectives of this Service Manual are to:

- Understand and follow proper safety precautions.
- Successfully troubleshoot and diagnose malfunctions.
- Successfully perform necessary repairs.
- Successfully return the washer to its proper operational status.

WHIRLPOOL CORPORATION assumes no responsibility for any repairs made on our products by anyone other than authorized In-Home Service Professionals.

TABLE OF CONTENTS

WHIRLPOOL & MAYTAG FRONT-LOAD WASHERS

SECTION 1 — GENERAL INFORMATION

| | |
|---|------|
| WASHER SAFETY | 1-2 |
| WHIRLPOOL CONTROL PANEL & FEATURES (HMI IN DOOR MODELS) | 1-3 |
| WHIRLPOOL CONTROL PANEL & FEATURES (CONSOLE MODELS) | 1-4 |
| MAYTAG CONTROL PANEL & FEATURES (CONSOLE MODELS) | 1-6 |
| DISPENSERS - WHIRLPOOL WASHERS ONLY | 1-9 |
| DISPENSERS - MAYTAG WASHERS ONLY | 1-9 |
| MODEL & SERIAL NUMBER LOCATION | 1-10 |
| WIRING DIAGRAM LOCATION | 1-10 |
| MODEL AND SERIAL NUMBER NOMENCLATURE | 1-11 |
| CLEANING THE DRAIN PUMP FILTER/DRAINING RESIDUAL WATER | 1-12 |
| PRODUCT SPECIFICATIONS | 1-13 |

SECTION 2 — DIAGNOSTICS & TROUBLESHOOTING

| | |
|---|------|
| WHIRLPOOL & MAYTAG DIAGNOSTICS (CONSOLE MODELS) | 2-2 |
| WHIRLPOOL CONTROL PANEL | 2-2 |
| MAYTAG CONTROL PANEL | 2-3 |
| ABBREVIATIONS | 2-4 |
| DIAGNOSTIC GUIDE | 2-4 |
| SERVICE DIAGNOSTIC MODE | 2-4 |
| ACTIVATING SERVICE DIAGNOSTIC MODE | 2-4 |
| SERVICE DIAGNOSTIC MENU | 2-4 |
| HUMAN-MACHINE INTERFACE (HMI) TEST | 2-5 |
| SOFTWARE VERSION DISPLAY | 2-5 |
| LOAD TEST AND QUICK SERVICE CYCLE | 2-6 |
| LOAD TEST CHART | 2-6 |
| QUICK SERVICE CYCLE CHART | 2-7 |
| FAULT/ERROR CODES | 2-8 |
| WHIRLPOOL DIAGNOSTICS (LCD IN DOOR MODELS) | 2-9 |
| ABBREVIATIONS | 2-9 |
| DIAGNOSTIC GUIDE | 2-9 |
| SERVICE DIAGNOSTIC MODE | 2-9 |
| ACTIVATING SERVICE DIAGNOSTIC MODE | 2-9 |
| SERVICE DIAGNOSTIC MODE TESTS | 2-10 |
| COMPONENT ACTIVATION | 2-11 |
| QUICK SERVICE CYCLE | 2-12 |
| FAULT/ERROR CODES | 2-13 |
| TROUBLESHOOTING GUIDE | 2-16 |
| MANUALLY UNLOCKING THE DOOR | 2-20 |

SECTION 3 — COMPONENT TESTING

| | |
|--|------|
| COMPONENT TESTING: SAFETY INFORMATION | 3-2 |
| WIRING DIAGRAM - WHIRLPOOL WASHER, LCD IN DOOR MODELS | 3-3 |
| WIRING DIAGRAM - WHIRLPOOL WASHER, CONSOLE MODELS | 3-4 |
| WIRING DIAGRAM - MAYTAG WASHER, CONSOLE MODELS | 3-5 |
| COMPONENT TESTING | 3-6 |
| TEST #1: ACU POWER CHECK | 3-6 |
| ACU BOARD/CONNECTORS & PINOUTS | 3-7 |
| TEST #2A: HUMAN-MACHINE INTERFACE (HMI) LCD IN DOOR MODELS | 3-8 |
| TEST #2B: HUMAN-MACHINE INTERFACE (HMI) CONSOLE MODELS | 3-9 |
| TEST #3: MOTOR CIRCUIT | 3-10 |
| TEST #4: DOOR LOCK SYSTEM | 3-11 |

Continued on next page . . .

TABLE OF CONTENTS

WHIRLPOOL & MAYTAG FRONT-LOAD WASHERS

SECTION 3 — COMPONENT TESTING (CONTINUED)

| | |
|--|------|
| TEST #5: DRUM LIGHT | 3-12 |
| TEST #6: WATER INLET VALVES | 3-13 |
| TEST #7: WATER LEVEL SENSOR | 3-14 |
| TEST #8: DRAIN/RECIRCULATION PUMP | 3-15 |
| TEST #9: WASH HEATING ELEMENT | 3-16 |
| TEST #10: WASH TEMPERATURE SENSOR | 3-17 |
| TEST #11A: SINGLE DOSE DISPENSER..... | 3-18 |
| TEST #11B: OPTIMAL DISPENSER-DOSING PUMP | 3-19 |
| TEST #12A: DRAWER BULK DISPENSER | 3-20 |
| TEST #12B: DRAWER BULK DISPENSER LEVEL SENSING | 3-21 |
| TEST #13: VENT FAN MOTOR | 3-22 |
| TEST #14: VENT BAFFLE SOLENOID | 3-23 |
| TEST #15: DRY HEATING ELEMENT | 3-24 |
| TEST #16: DRY TEMPERATURE SENSOR..... | 3-25 |
| TEST #17: DRY BLOWER MOTOR | 3-26 |

SECTION 4 — COMPONENT ACCESS

| | |
|---|------|
| REMOVING THE TOP PANEL | 4-2 |
| REMOVING THE REAR PANEL | 4-3 |
| REMOVING THE WATER LEVEL SWITCH | 4-4 |
| REMOVING THE RFI FILTER | 4-5 |
| REMOVING THE DRUM LIGHT..... | 4-6 |
| REMOVING THE DVT FAN/VENT ASSEMBLY | 4-7 |
| REMOVING THE WATER INLET VALVES | 4-8 |
| REMOVING THE APPLIANCE CONTROL UNIT (ACU) | 4-9 |
| REMOVING THE TOP REAR BRACKET..... | 4-10 |
| REMOVING THE WASH HEATER/THERMISTOR ASSEMBLY..... | 4-11 |
| REMOVING THE DRYER HEATING CHANNEL ASSEMBLY | 4-12 |
| REMOVING THE CONDENSER DUCT ASSEMBLY | 4-13 |
| REMOVING THE DOOR ASSEMBLY | 4-14 |
| REMOVING THE DOOR LOCK ASSEMBLY | 4-15 |
| REMOVING THE FRONT CONSOLE | 4-16 |
| REMOVING THE FRONT PANEL | 4-17 |
| REMOVING THE SINGLE DOSE DISPENSER ASSEMBLY | 4-18 |
| REMOVING THE DIRECT DRIVE MOTOR | 4-19 |
| REMOVING THE BULK DISPENSE ASSEMBLY | 4-20 |
| REMOVING THE DRAIN/RECIRCULATION PUMPS | 4-22 |
| REMOVING THE TUB ASSEMBLY | 4-23 |

SECTION 5 — CONNECTIVITY

| | |
|--|-----|
| INTERNET CONNECTIVITY GUIDE..... | 5-2 |
| INITIAL SETUP..... | 5-2 |
| DOWNLOAD AND INSTALL WITH TOUCH SCREEN | 5-2 |
| DOWNLOAD AND INSTALL WITH NON-TOUCH SCREEN | 5-2 |
| TROUBLESHOOTING GUIDE | 5-3 |

PRODUCT SPECIFICATIONS & WARRANTY INFORMATION SOURCES (inside back cover)

Section 1: General Information

This section provides general safety, parts, and information for the “Whirlpool & Maytag Front-Load Washers.”

- Washer Safety
- Whirlpool Control Panel & Features (HMI in Door)
- Whirlpool Control Panel & Features (Console)
- Maytag Control Panel & Features (Console)
- Dispensers – Whirlpool Washers
- Dispensers – Maytag Washers
- Wiring Diagram Location
- Model & Serial Number Location
- Model & Serial Number Nomenclature
- Cleaning the Drain Pump/Draining Residual Water
- Product Specifications

Washer Safety

Your safety and the safety of others are very important.

We have provided many important safety messages in this manual and on your appliance. Always read and obey all safety messages.



This is the safety alert symbol.

This symbol alerts you to potential hazards that can kill or hurt you and others.

All safety messages will follow the safety alert symbol and either the word "DANGER" or "WARNING."

These words mean:

⚠ DANGER

You can be killed or seriously injured if you don't immediately follow instructions.

⚠ WARNING

You can be killed or seriously injured if you don't follow instructions.

All safety messages will tell you what the potential hazard is, tell you how to reduce the chance of injury, and tell you what can happen if the instructions are not followed.

Whirlpool Control Panel & Features (HMI in Door Model)

Not all features and cycles are available on all models.

NOTE: The control panel features a sensitive surface that responds to a light touch of your finger. To ensure your selections are registered, touch the control panel with your fingertip, not your fingernail. When selecting a setting or option, simply touch the appropriate button.

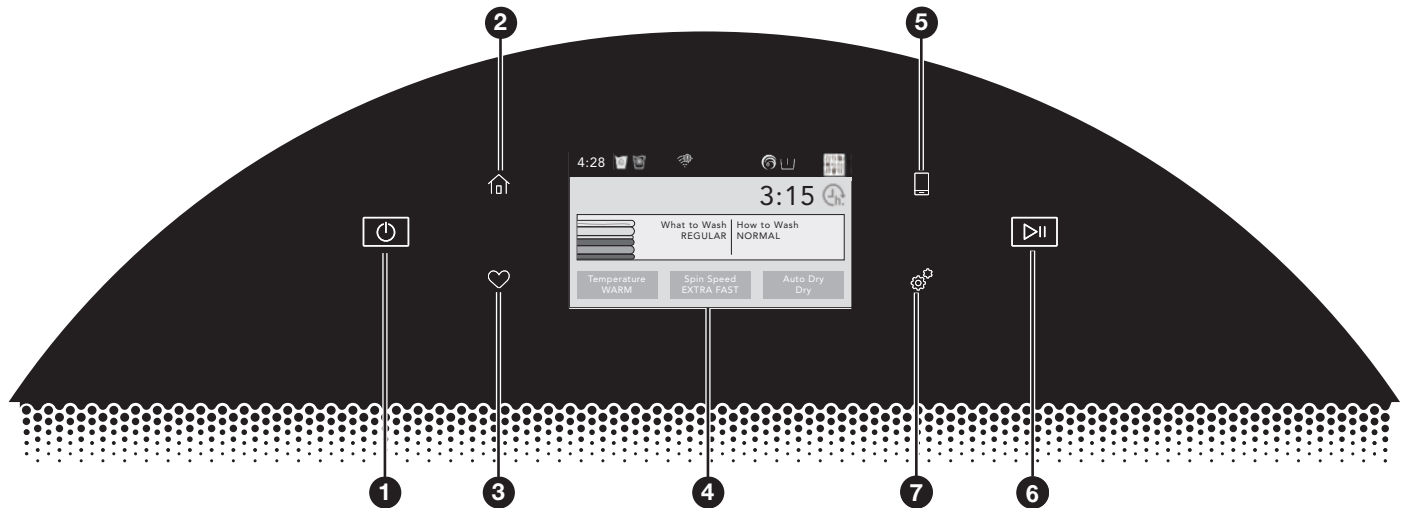

1 POWER BUTTON

Touch to power up the washer.

2 HOME BUTTON

Touch this button and the LCD screen will show the home screen, where you can select your cycle, settings, and options..

3 FAVORITES BUTTON

Stores and accesses your favorite cycles and a history of your recently run cycles.

4 LCD SCREEN

Use this screen to select cycle, settings, options, etc.

5 REMOTE ENABLE BUTTON

Download the Whirlpool™ app and follow the instructions to connect your washer to your home Wi-Fi network. You may also visit www.whirlpool.com/connect. In Canada, visit www.whirlpool.ca/connect. After connecting to WiFi, touch the REMOTE ENABLE button any time you want to use the app. Touching this button locks out the LCD screen and you will be prompted with a message about the washer waiting for input from the app. If you want to exit this mode, touch the REMOTE ENABLE button again.

6 START/PAUSE BUTTON

Touch and hold to start, or touch to pause a cycle. When you start a cycle, the door will lock, the washer will sense the load size, and the wash cycle will begin.

7 TOOLS BUTTON

The Tools button gives access to many other settings, utility cycles, preferences, and information (see next column). Touch the TOOLS button to access the Tools screen, which contains the following (you will need to scroll down with your finger to access all of the selections):

Load & Go™ Dispenser 1

Touch this icon to access Load & Go™ Status Dispenser 1 and choose between; Active, Disabled (1 Cycle), or Off (Permanently), and select detergent concentration of 2X, 3X, 4X, 5X, 6X, and 8X.

Load & Go™ Dispenser 2

Touch this icon to access Load & Go™ Status Dispenser 1 and choose between; Active, Disabled (1 Cycle), or Off (Permanently), choose between Softener or Detergent content, and select detergent concentration of 2X, 4X, 6X, and 8X.

Control Lock

Touch this icon to lock the controls. Swipe up to unlock.

Mute

Touch this icon to mute or unmute sounds.

Utility Cycles

Touch this icon to access the following utility cycles: Drain & Spin and the Clean Washer with affresh® cycle. Touch the utility cycle you wish to use and follow the screen prompts.

NOTE: To get a Rinse & Spin cycle, select Drain & Spin and the Extra Rinse option.

Preferences

Touch to access Times and Dates, Sound Volume, Display Settings, and Regional. Follow the screen prompts.

WiFi

Touch to access Connect to Network, SAID (Smart Appliance ID) Codes, Mac Address, and WiFi. Follow the screen prompts.

Info

Touch to access Service & Support, Store Demo Mode, Restore Factory, WiFi Terms and Conditions, and Software Terms and Conditions. Follow the screen prompts.

NOTE: All changes to settings will remain in effect until settings are changed again.

Whirlpool Control Panel & Features (Console Models)

NOTES:

- Not all features and cycles are on all models.
- If your model has a touch interface, the control panel features a sensitive surface that responds to a light touch of your finger. To ensure your selections are registered, touch the control panel with your fingertip, not your fingernail. When selecting a setting or option, simply touch its name.
- If your model has physical buttons, make sure to press the button firmly.
- At cycle completion, your setting and option choices will be remembered for the next cycle. However, if power to the washer is lost, the settings and options will go back to the factory defaults.

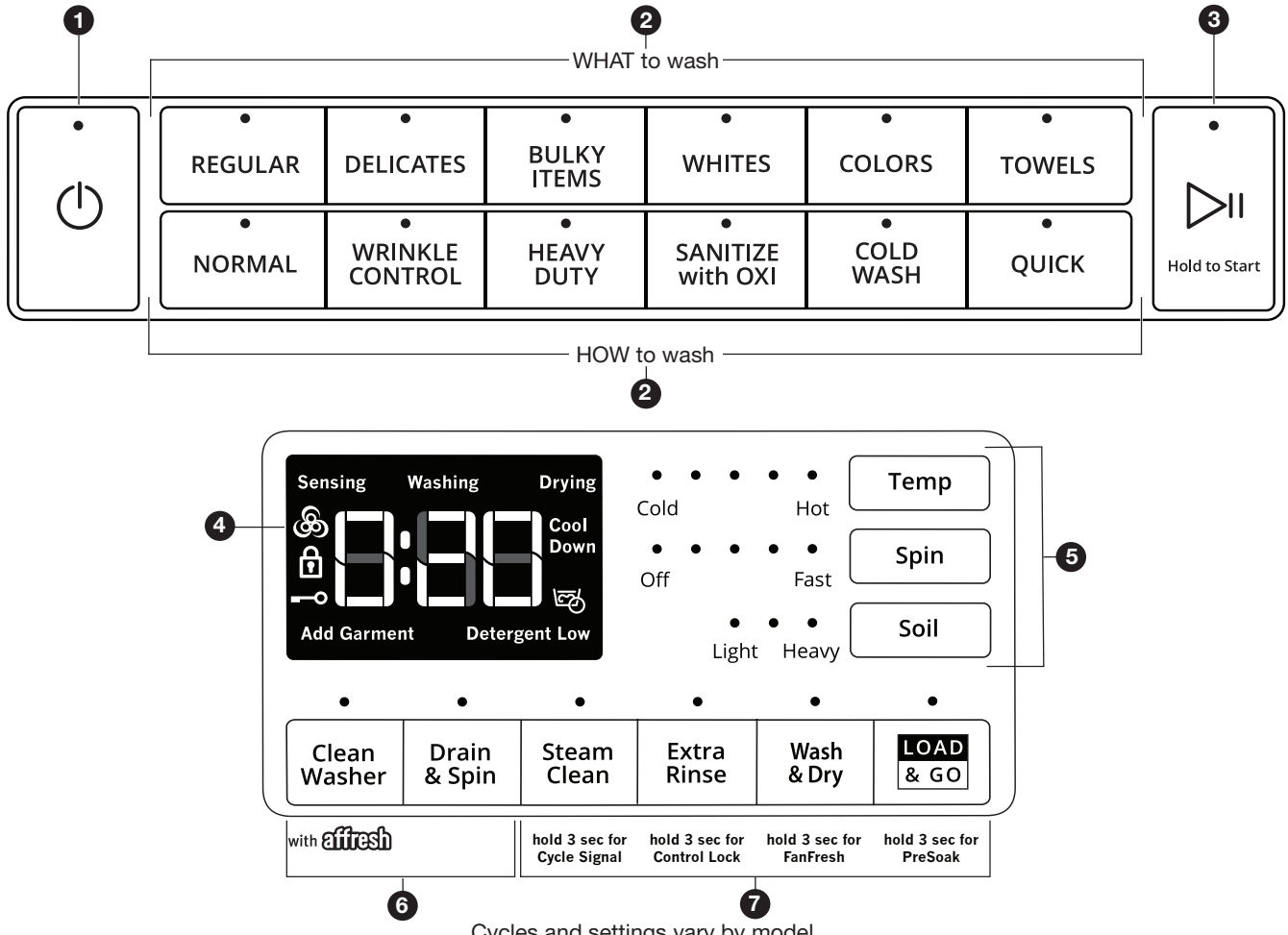

Cycles and settings vary by model.

1 POWER

Select to turn the washer on and off. Select to stop/cancel a cycle at any time.

2 WHAT TO WASH/HOW TO WASH

First determine what items are in the load that you are trying to wash. Use that to guide your “What to Wash” selection. Then determine how you want the washer to wash them and make the appropriate “How to Wash” selection.

3 START/PAUSE

Touch and hold for 3 seconds until the light above Start/ Pause comes on to start a cycle, or touch once while a cycle is in process to pause it.

4 CYCLE STATUS DISPLAY

The Cycle Status Display shows the progress of a cycle. At each stage of the process, you may notice sounds or pauses that are different from traditional washers.

Estimated Time Remaining

The Estimated Time Remaining shows the time required for the cycle to complete. Factors such as load size, modifiers, options selected, and water pressure may affect the time shown in the display. Tightly packed loads, unbalanced loads, or excessive suds may cause the washer to lengthen the cycle time as well.

Sensing

When Start/Pause is touched the washer will chime, indicating it is starting. The drum will make a partial turn. The door will click when it locks.

Once the door has locked, the washer will begin spinning to sense the load size. This sensing process will continue throughout the cycle.

After the load size is sensed, the estimated time based on load size will be displayed and water will be added. You may hear water flowing through the dispenser, adding detergent to the load. The actual cycle time may be lengthened; however, the display will continue to show the estimated time.

Washing

During the wash cycle, this will display to let you know the cycle is in progress.

Drying (on some models)

During a drying cycle, this will display to let you know the drying cycle is in progress.

Cool Down (on some models)

At the end of a drying cycle, your load will go through a cool-down period.

PreSoak

This symbol will be displayed to let you know a presoak is in progress.



Detergent Low (on some models)

When detergent in the bulk dispenser is running low, the display will show the detergent level (Low).

Add Garment

When "Add Garment" is displayed, you may pause the washer, open the door, and add items. Touch and hold START/PAUSE to start the washer again.

Door Locked

The Door Locked symbol will display to indicate that the door is locked and cannot be opened without first pausing or canceling the cycle.



Control Lock

When the Control Lock or "Loc" symbol is displayed, the buttons are disabled. Touch and hold EXTRA RINSE for 3 seconds to enable the buttons.



FanFresh® (on some models)

This symbol will be displayed when the FanFresh® option is activated. The fan will turn on and the load will tumble periodically for up to 12 hours.



End

Once the cycle is complete, "End" will display. Remove the load promptly for best results.

5 CYCLE MODIFIERS

When you select a cycle, its default settings will light up. Touch to adjust cycle modifiers on the washer before touching START/PAUSE. Additional wash modifiers or options selected after touching Start/Pause may not activate. Once a wash setting is selected, it is saved for the cycle selected. To return to factory default cycle settings, unplug washer for 30 seconds; then plug back in.

NOTE: Some modifiers may increase or decrease the estimated time remaining.

Temp

The recommended wash temperature is preset for each cycle. Some preset temperatures can be changed. You may select a different wash temperature based on the level of soil and type of fabric being washed. For best results, use the warmest wash water safe for your fabric, following the garment label instructions. All wash temperatures feature a cold rinse.

Spin

The recommended spin speed is preset for each cycle. Some preset speeds can be changed.

- Faster spin speeds mean shorter dry times, but may increase wrinkling in your load.
- Slower spin speeds reduce wrinkling, but will leave your load more damp.

Soil

The recommended soil level is preset for each cycle. Some preset soil levels can be changed. For heavily soiled and sturdy fabrics, select the Heavy Soil Level setting. For lightly soiled and delicate fabrics, select the Light Soil Level setting. Lower soil level settings will help reduce tangling and wrinkling.

6 UTILITY CYCLES

Clean Washer

Use this every 30 washes to keep the inside of your washer fresh and clean. This cycle uses a higher water level. Use with affresh® Washer Cleaner tablets or liquid chlorine bleach to thoroughly clean the inside of your washer. When using this cycle, the drum should be empty. This cycle should not be interrupted.

Drain & Spin

This cycle removes excess water from the load or special-care items washed by hand. Use this cycle after a power failure. For some fabrics, you may choose to set a slower spin speed.

7 CYCLE OPTIONS

You may add or remove options for each cycle. Not all options can be used with all cycles, and some are preset to work with certain cycles. Options vary by model.

Steam Clean (on some models)

The Steam Clean option adds additional soak and wash time to many cycles to help remove tough stains, as well as a steam boost for added cleaning power. An integrated heater helps to maintain optimal wash temperatures.

You can also touch and hold STEAM CLEAN for 3 seconds to turn cycle signals on or off.

Extra Rinse

Activate this option to add an extra rinse to most cycles.

You can also touch and hold EXTRA RINSE for 3 seconds to disable/enable the Control Lock.

Wash & Dry (on some models)

Touch to add a drying cycle to your load after the wash cycle has finished. The Wash & Dry option is designed to wash and dry 2-4 lightly soiled synthetic garments, athletic uniforms, or workout wear. This option has an extra-high-speed spin followed by intermittent tumbling and fan activation to circulate air through the clothes.

You can also touch and hold WASH & DRY for 3 seconds to activate/deactivate the FanFresh® option. Use the FanFresh® option if you will be unable to remove the load promptly. The washer will automatically activate the fan after the cycle ends and tumble the load periodically for up to 12 hours.



IMPORTANT:

- Do not use dryer sheets.
- Do not dry comforters or large blankets.

Load & Go™ (on some models)

Touch to select this option If you want to automatically add HE detergent to the wash load at the proper time.

IMPORTANT: When using the dispenser cartridge with concentrated liquid detergent, be sure to change the detergent concentration settings in the control if the detergent used is different than factory preset of 2x concentration. Change the detergent concentration setting by touching and holding TEMP and SOIL for 3 seconds.

You can also touch and hold LOAD & GO™ for 3 seconds to set a presoak.

PreSoak (on some models)

Touch to add a presoak time of your choice to a wash cycle.



GENERAL INFORMATION

Maytag Control Panel & Features (Console Models)

Not all features and cycles are available on all models.

NOTES:

- The control panel features a sensitive surface that responds to a light touch of your finger. To ensure your selections are registered, touch the control panel with your fingertip, not your fingernail. When selecting a setting or option, simply touch its name.
- At cycle completion, your setting and option choices will be remembered for your next use of that cycle. However, if power is lost to the washer, the settings and options will go back to the factory defaults.

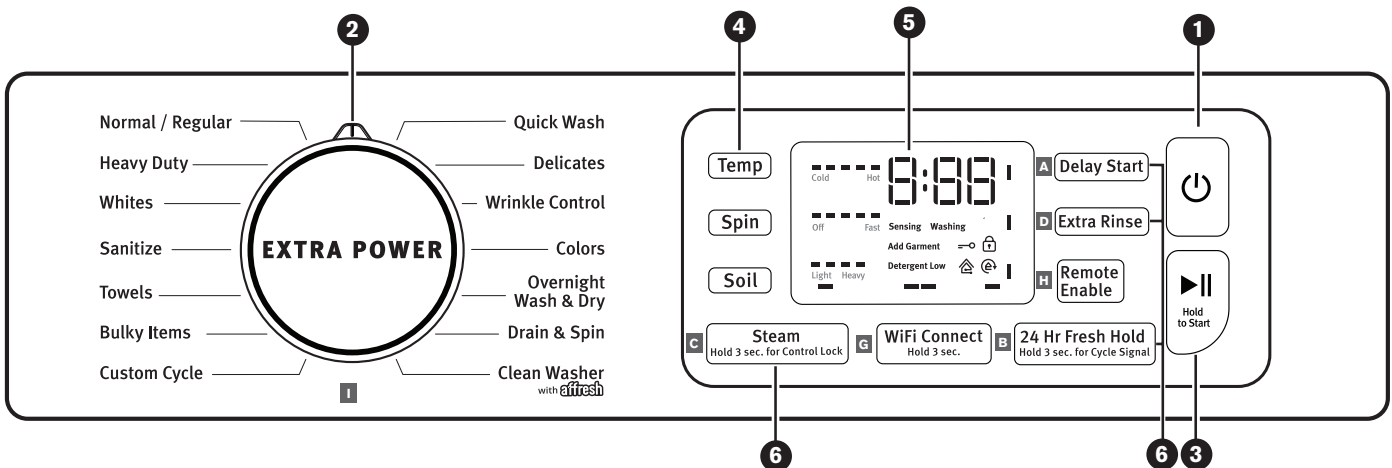
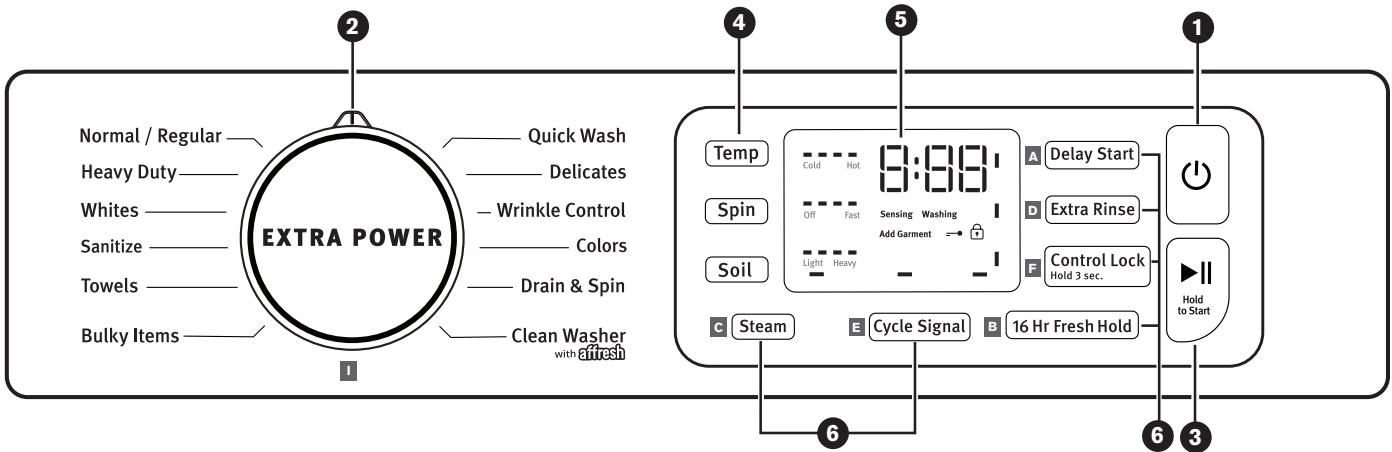
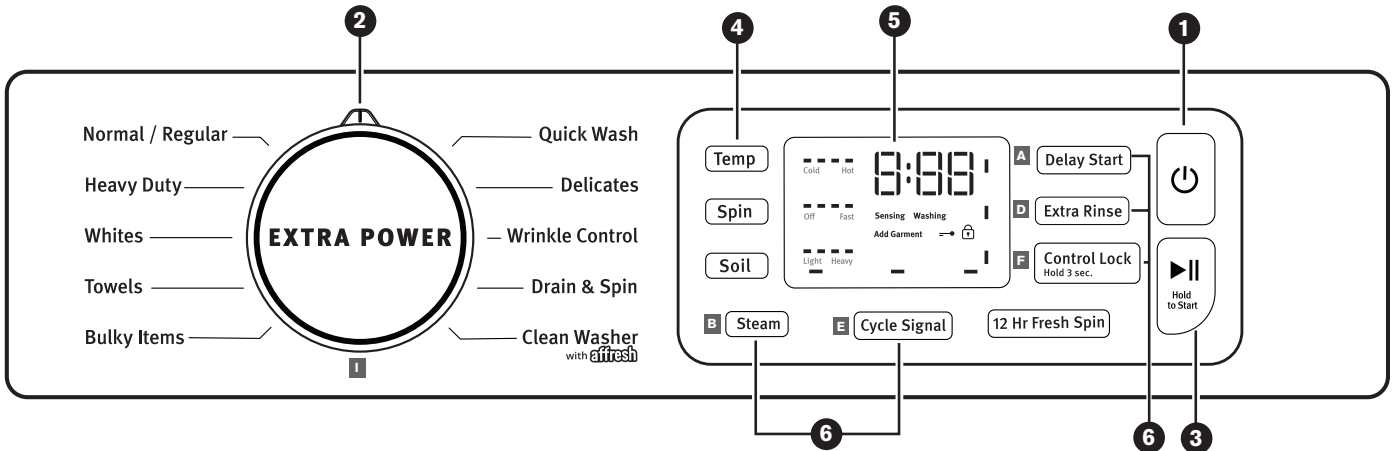

Maytag Control Panel & Features (continued)

1 POWER

Touch to turn the washer on and off. Touch to stop/cancel a cycle at any time.

NOTE: Turning the Wash Cycle knob will also turn the washer on.

2 WASH CYCLE KNOB

Turn the knob to select a cycle for your laundry load. Press the Wash Cycle knob to enable the Extra Power option.

NOTE: The Clean Washer with affresh® LED will flash when the washer has run 30 wash cycles as a reminder to run the Clean Washer with affresh® cycle.

NOTE: For best results when using the Overnight Wash & Dry cycle, use for loads weighing 2 lbs or less, such as a soccer uniform or a running tank and shorts. Allow the cycle to run the full duration of 12 hours.

EXTRA POWER

Extra Power option can be used for increased cleaning power. Press the Wash Cycle Knob to activate the Extra Power option, which runs a cold pre-wash cycle before the main cycle. When Extra Power is activated, the Cycle Control Knob will illuminate and the estimated time remaining on the display will increase. On single load dispenser models, add an extra dose of detergent to the Bleach/Detergent for Extra Power compartment when using Extra Power, for best results.

3 START

Touch and hold for 3 seconds until the light above START comes on to start a cycle or touch once while a cycle is in process to pause it. If you want to add a garment, you can touch START when the “Add Garment” LED is on.

4 LED DISPLAY AND SETTINGS

When you select a cycle, its default settings will light up and the Estimated Time Remaining will be displayed. Factors such as load size, wash temperature, and water pressure may affect the time shown in the display. Tightly packing, unbalanced loads, or excessive suds may cause the washer to lengthen the cycle time as well.

Touch the desired setting on the display to adjust.

Temp

The recommended wash temperature is preset for each cycle. You may also select a wash temperature based on the type of fabric and soils being washed. For best results, use the warmest wash water safe for your fabric, following the garment label instructions. All wash temperatures feature a cold rinse.

Spin

This washer automatically selects the spin speed based on the cycle selected. Some preset speeds can be changed.

- Faster spin speeds mean shorter dry times but may increase wrinkling in your load.
- Slower spin speeds reduce wrinkling but will leave your load more damp.

Soil

Soil Level (wash time) is preset for each wash cycle. When you change the soil setting, the cycle time will increase or decrease in the Estimated Cycle Time display.

For most loads, use the soil level that is preset with the cycle you have chosen. For heavily soiled and sturdy fabrics, use the Soil Level setting to select a higher soil level. For lightly soiled and delicate fabrics, use the Soil Level setting to select a lower soil level. Lower soil level settings will help reduce tangling and wrinkling.

5 CYCLE STATUS LIGHTS

NOTE: Not all Cycle Status Lights are available on all models.

The Cycle Status Lights show the progress of a cycle. At each stage of the process, you may notice sounds or pauses that are different from traditional washers.

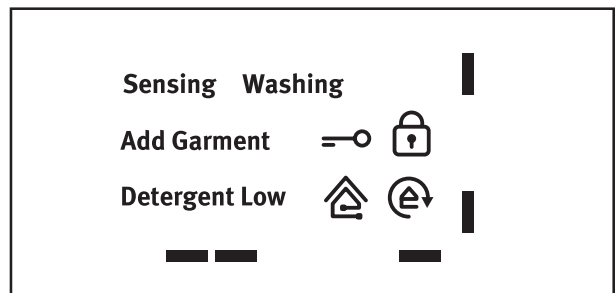

Sensing

When START is touched and held, the washer will first perform a self-test and the sensing light will come on. The drum will make a partial turn and then stop for a few seconds. Then, a click will be heard as the door locks.

Once the door has locked the second time, the washer will begin spinning to sense the load size. This sensing process will continue throughout the cycle. You may also hear water flowing through the dispenser, adding detergent to the load.

After the load size is sensed, the estimated time based on load size will be displayed. The actual cycle time may be lengthened; however, the display will continue to show the estimated time.

The sensing light will blink once a second at various times during the cycle, such as when the washer is reducing extra suds.

Washing

During the wash cycle, this will display to let you know the cycle is in progress.

Add Garment

When “Add Garment” is lit, you may pause the washer, open the door, and add items. Touch and hold START to start the washer again.

Detergent Low

When detergent in the dispenser is running low, the display will show the detergent level (Low).

6 OPTIONS

Touch to activate additional wash options or additional features on the washer. Not all options are available on all models.

A Delay Start

Touch this option to delay the start of the wash cycle by up to 12 hours.

Options - continued on next page . . .

Maytag Control Panel & Features (continued)

B Fresh Hold®/Fresh Spin™

The Fresh Hold®/Fresh Spin™ option will periodically tumble the load after the end of the cycle for up to 24 hours while the integrated fan circulates air through the washer to reduce humidity. Fresh Spin™ also periodically tumbles the load after the end of the cycle but does not use an integrated fan. To turn on the Fresh Hold®/Fresh Spin™ option, touch FRESH HOLD. If, however, the Fresh Hold®/Fresh Spin™ option is turned on, it will stay on for all future cycles until turned back off – the washer remembers the last on/off status set. To turn off the Fresh Hold®/Fresh Spin™ option, touch FRESH HOLD.

To turn off the Fresh Hold®/Fresh Spin™ option when it is running, touch POWER.

NOTE: The door will lock while the Fresh Hold®/Fresh Spin™ option is active. To cancel the option and unlock the door, touch POWER.

C Steam

The Steam option adds additional soak and wash time to many cycles to help remove tough stains as well as a steam boost for added cleaning power. An integrated heater helps to maintain optimal wash temperatures.

D Extra Rinse

Activate this option to add an extra rinse to most cycles.

E Cycle Signal

Touch and hold CYCLE SIGNAL for about 3 seconds the display will count down you will see “3,” then “2,” then “1.” The display will start displaying the sound levels you will see “1,” then “2,” then “3,” then “OFF.” When the CYCLE SIGNAL is released the last value shown will be the current selection.

F Control Lock

Touch and hold for 3 seconds to lock the controls to avoid unwanted changes or operation. Touch and hold 3 seconds again to unlock. For each second CONTROL LOCK is held down, the display will count down 1 second; you will see “3,” then “2,” then “1.” You may still touch START to pause the cycle or touch POWER to turn off the washer.

G WiFi Connect

Download the Maytag® app and follow the instructions to connect your washer to your home WiFi network. You may also visit www.maytag.com/connect. In Canada, visit www.maytag.ca.

H Remote Enable

Touch this button to be able to use the Maytag® app to remotely control the washer, if Remote Enable is desired. Press this button each time after Power On and when the door is opened and closed.

I Extra Power

The Extra Power option boosts stain fighting performance on any wash cycle with a dual temperature wash, combining cold and hot temperature during different phases of the wash time. To use this function press the knob to activate the Extra Power option. For single dose dispensers add an additional 1/2 the manufacturer’s recommended amount into the dispenser marked for Extra Power. For Optimal Dispenser it will automatically dispense the detergent at the optimal time.

Remote Enable

Touch this button to be able to use the Maytag® app to remotely control the washer, if Remote Enable is desired. Press this button each time after Power On and when the door is opened and closed.

Extra Power

The Extra Power option boosts stain fighting performance on any wash cycle with a dual temperature wash, combining cold and hot temperature during different phases of the wash time. To use this function press the knob to activate the Extra Power option. For single dose dispensers add an additional 1/2 the manufacturer’s recommended amount into the dispenser marked for Extra Power. For Optimal Dispenser it will automatically dispense the detergent at the optimal time.

Dispensers – Whirlpool Washers Only

Load & Go™ Bulk Dispenser (Varies by model)

The Load & Go™ dispenser gives you the convenience of not having to add HE detergent and fabric softener to the wash load every time. It also determines the best time and amount to add the detergent to the load.

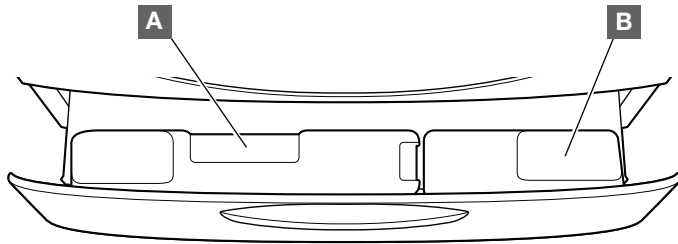

A 2-Liter Bulk Liquid High Efficiency (HE) detergent dispenser

This bulk dispenser holds up to 67.6 oz (2 L) of liquid HE detergent.

B 1-Liter Bulk Liquid High Efficiency (HE) detergent/fabric softener dispenser

This bulk dispenser holds up to 33.8 oz (1 L) of liquid HE detergent or liquid fabric softener. Each dispenser holds enough detergent or fabric softener for many loads of laundry. Each adds the appropriate quantity to the wash load at the proper time.

IMPORTANT: Do not use chlorine bleach or powdered detergent in the bulk dispenser. Powdered detergent and bleach must be added to the single load dispenser.

Single-load dispenser drawer

The single-load dispenser drawer gives you the convenience of adding HE detergent, liquid chlorine bleach, and liquid fabric softener to the wash load at the proper time.

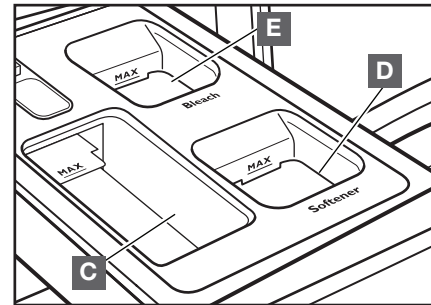

C High Efficiency (HE) detergent compartment

This compartment holds liquid or powdered HE detergent for your main wash cycle, and automatically dispenses detergent in the cycle.

D Liquid fabric softener compartment

This compartment holds liquid fabric softener. It automatically dispenses liquid fabric softener at the optimum time in the cycle.

E Liquid chlorine bleach compartment

This compartment automatically dilutes and dispenses liquid chlorine bleach at the optimum time during the first rinse after the wash cycle. It cannot dilute powdered bleach.

Dispensers – Maytag Washers Only

Optimal Dispense Drawer (on some models)

The Optimal Dispense drawer gives you the convenience of automatically adding HE detergent, liquid chlorine bleach, and liquid fabric softener to the wash load at the proper time.

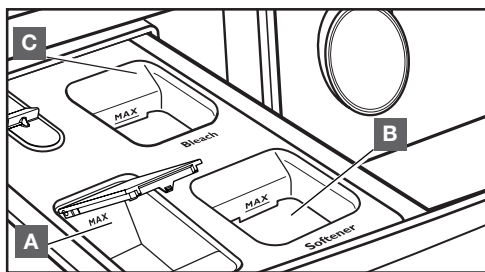

A Optimal Dispense Liquid High Efficiency “HE” detergent compartment

This compartment holds up to 14.3 oz (424 ml) of liquid HE detergent allowing you to avoid having to refill detergent for each load. Also, this will use just the right amount of detergent required for a particular load/cycle.

B Liquid fabric softener compartment

Automatically dilutes and dispenses liquid fabric softener at the optimum time in the cycle.

- Use only liquid fabric softener in this dispenser.

Single Load Dispenser Drawer (on some models)

The dispenser drawer gives you the convenience of adding HE detergent, liquid chlorine bleach, and liquid fabric softener to the wash load at the proper time.

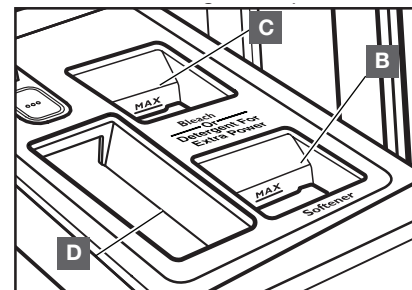

C Liquid chlorine bleach compartment

Automatically dilutes and dispenses liquid chlorine bleach at the optimum time during the first rinse after the wash cycle. This compartment cannot dilute powdered bleach. On single load dispenser models, use this compartment to add an extra dose of detergent when using the Extra Power option.

D Liquid High Efficiency “HE” detergent compartment

This compartment holds liquid or powdered HE detergent for your main wash cycle.

Model & Serial Number Location



Figure 1 - Model / Serial Number

Wiring Diagram Location

Wiring Diagram located under Top Panel
taped to rear top bracket

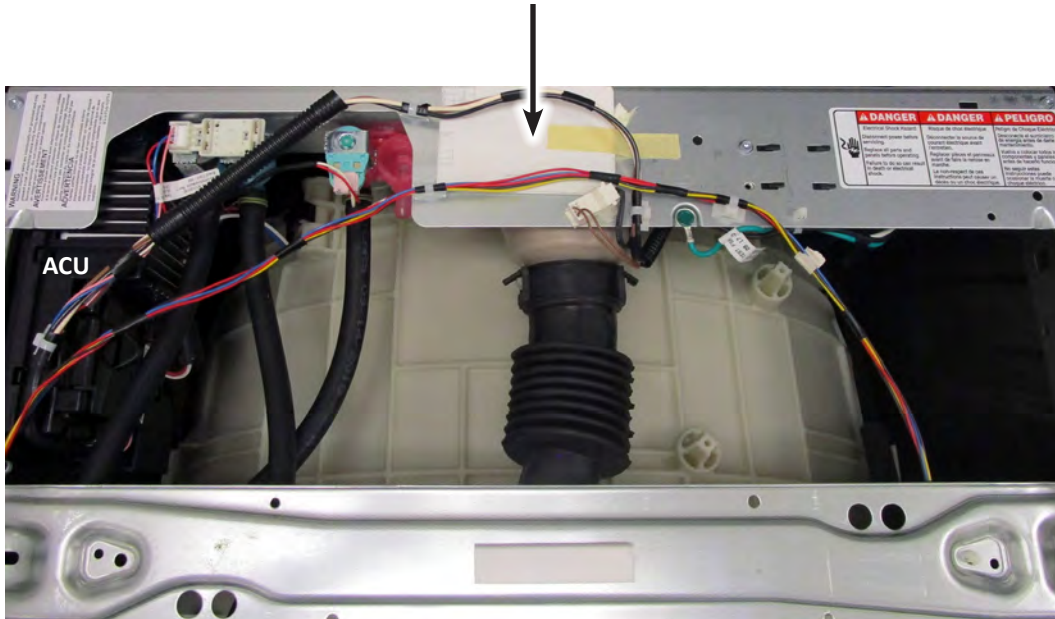
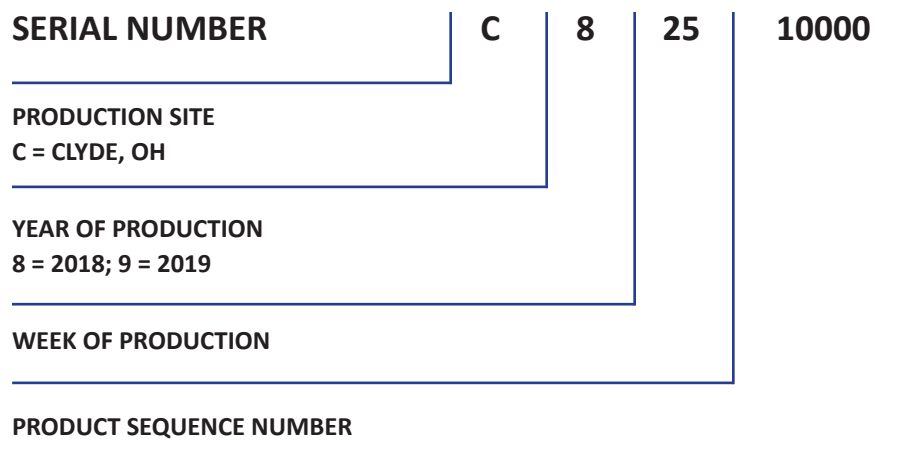
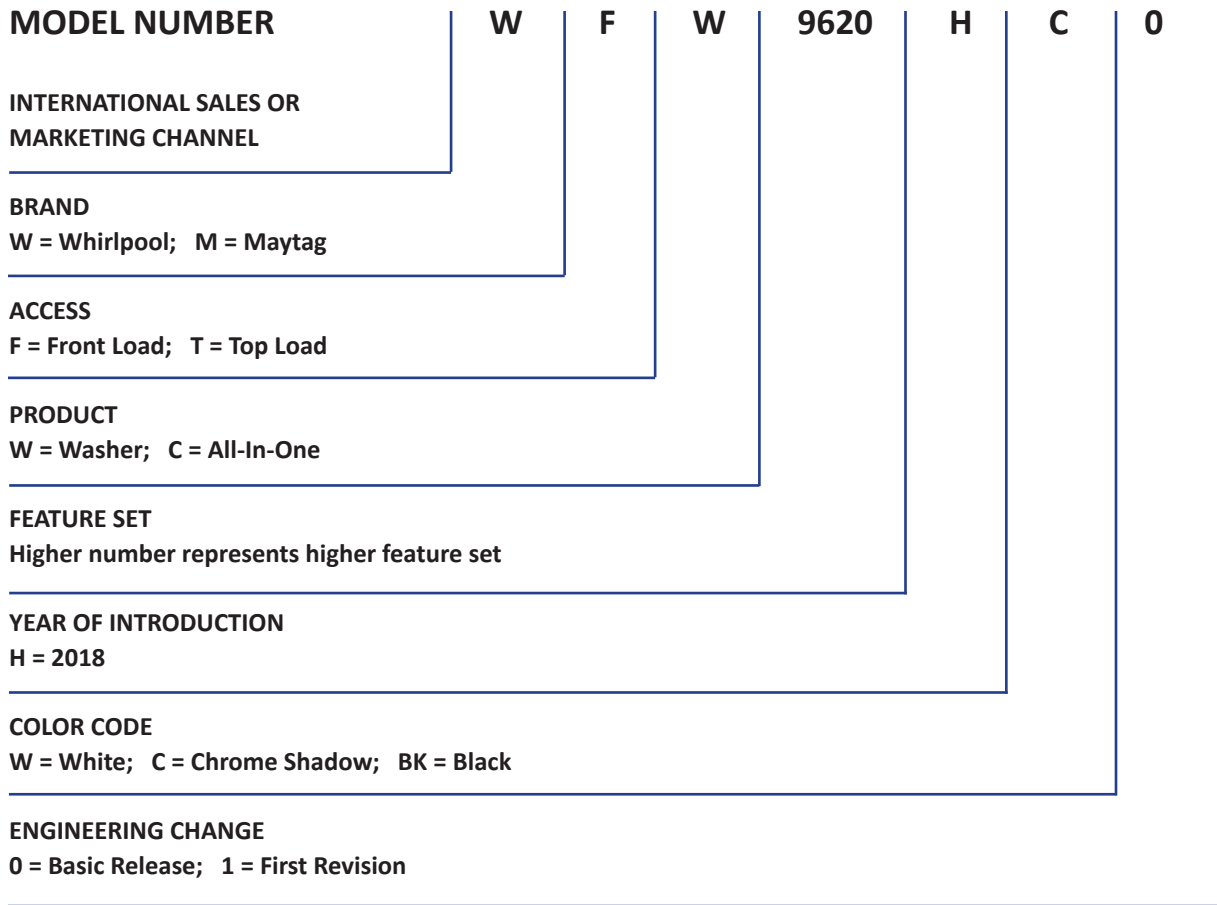

Figure 2 - Wiring Diagram Location

Model & Serial Number Nomenclature



GENERAL INFORMATION

Cleaning the Drain Pump Filter/Draining Residual Water

NOTE: The following instructions only apply to the Whirlpool front-load washers.

1. Open the dispenser drawer by pulling on the handle at the base of the washer. This will reveal the drain pump filter. Remove the drawer by releasing the tab on each side. See Figure 1.

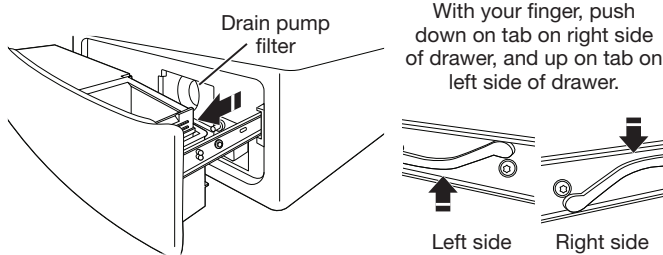

Figure 1

2. Place a broad, flat container beneath the drain pump filter to collect the drain water. Release the black hose from the hose clip, remove the plug, and drain the hose into the container (see Figure 2). Empty the container. Repeat this procedure if necessary until all the water has drained. Make sure that the black hose is completely dry, replace the plug, and secure the hose in the clip.

NOTE: If water does not drain well, push in hose slightly to remove any possible kinks.

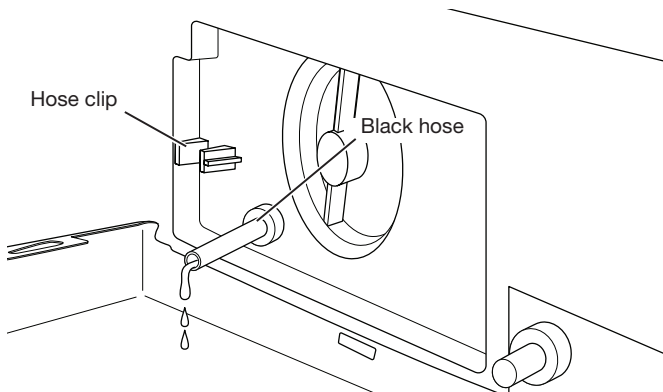
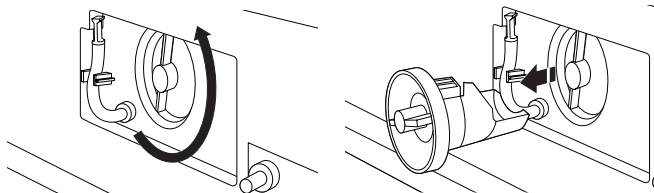

Figure 2

3. Lay a cotton cloth beneath the drain pump filter to absorb any water still in it. Then remove the drain pump filter by turning it counterclockwise. See Figure 3.



4. Remove large clumps of lint by hand from the filter and place lint in a suitable waste container. Remove remaining residue from the filter by rinsing with water (see Figure 4).

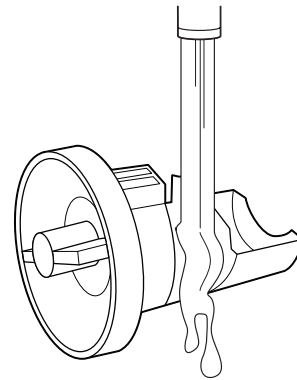

Figure 4

5. Reinsert the drain pump filter by turning it clockwise. Make sure to turn it in as far as it will go, with the filter handle remaining as close as possible to the vertical position. See Figure 5.

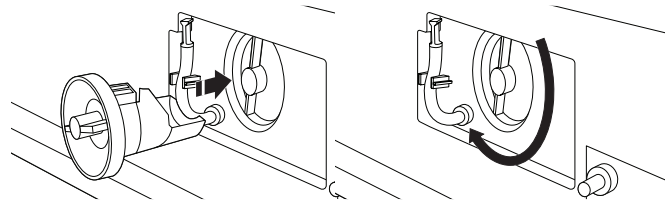

Figure 5

6. Replace and close the dispenser drawer. Make sure to insert both rails simultaneously when replacing the drawer. You will hear a clicking sound that indicates the rails have engaged (see Figure 6). To ensure proper placement of the drawer, pull out fully. The drawer should be fully engaged and the rails locked in place. Make sure the drain hose is secured in the hose clip and tucked underneath the cutout.

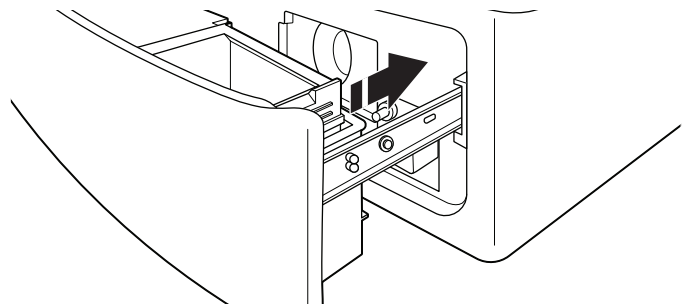

Figure 6

Product Specifications

| ELECTRICAL | |
|----------------------------------|--|
| Voltage : | 120 VAC |
| Hertz : | 60 Hz |
| Amps : | 15-20 Amps Service |
| PRIMARY FEATURES* | |
| Capacity : | 4.5, 4.8, 5.0 cu. ft. (Maytag) 4.3, 4.5, 5.0 cu. ft. (Whirlpool) |
| Control Panel : | (Whirlpool) Front Console / Capacitive Touch / Electronic (Whirlpool) Display In Door / LCD Screen / Touch Screen (Maytag) Front Console/ Indicator Lights / Cycle Select Knob |
| Drum Material : | Stainless Steel |
| Door Style : | Left Door Swing, Window |
| Motor Drive Type : | Direct Drive |
| Maximum Spin Speed : | 1160 RPM |
| Automated Dispenser : | Load & Go™ (Varies by model) |
| Dispense System : | Detergent, Fabric Softener, Bleach |
| Fan Type : | Fan Fresh® |
| Automatic Load Size Sensing : | Yes |
| Out of Balance Sensing : | Yes |
| Recirculation Pump : | Yes |
| Advanced Vibration Control : | Yes |
| Sanitize : | Yes |
| Internal Heater : | Select Models |
| Steam Option : | Select Models |
| Interior Light : | Select Models |
| Closet Depth : | Select Models |
| Smart Appliance/Remote Control : | Select Models |
| INSTALLATION CONSIDERATIONS | |
| Pedestal Options : | Yes |
| Stackable : | Yes |
| OPTIONS* | |
| Control Lock : | Locks the controls of the dryer |
| Cycle Signal : | Sound when cycle is complete |
| Wash and Dry Option : | Select Models |
| DIMENSIONS | |
| Height : | 38 5/8" (98.4 cm) |
| Width : | 27" (68.58 cm) |
| Standard Depth : | 33 1/4" (84.46 cm) |
| Closet Depth (Slim) : | 31 1/2" (80 cm) |
| Gross Weight : | Varies by model |

* Features and Options vary by brand and model.

Notes

Section 2: Diagnostics & Troubleshooting

This section provides diagnostic, fault codes, and troubleshooting information for the “Whirlpool & Maytag Front-Load Washers.”

- Control Panel
- Abbreviations
- Diagnostic Guide
- Service Diagnostic Mode
- Fault/Error Codes
- Troubleshooting Guide
- Manually Unlocking the Door

Whirlpool & Maytag Console Diagnostics

WHIRLPOOL CONTROL PANEL (features and appearances may vary between models) (buttons to use when entering Service Diagnostic Mode & Tests)

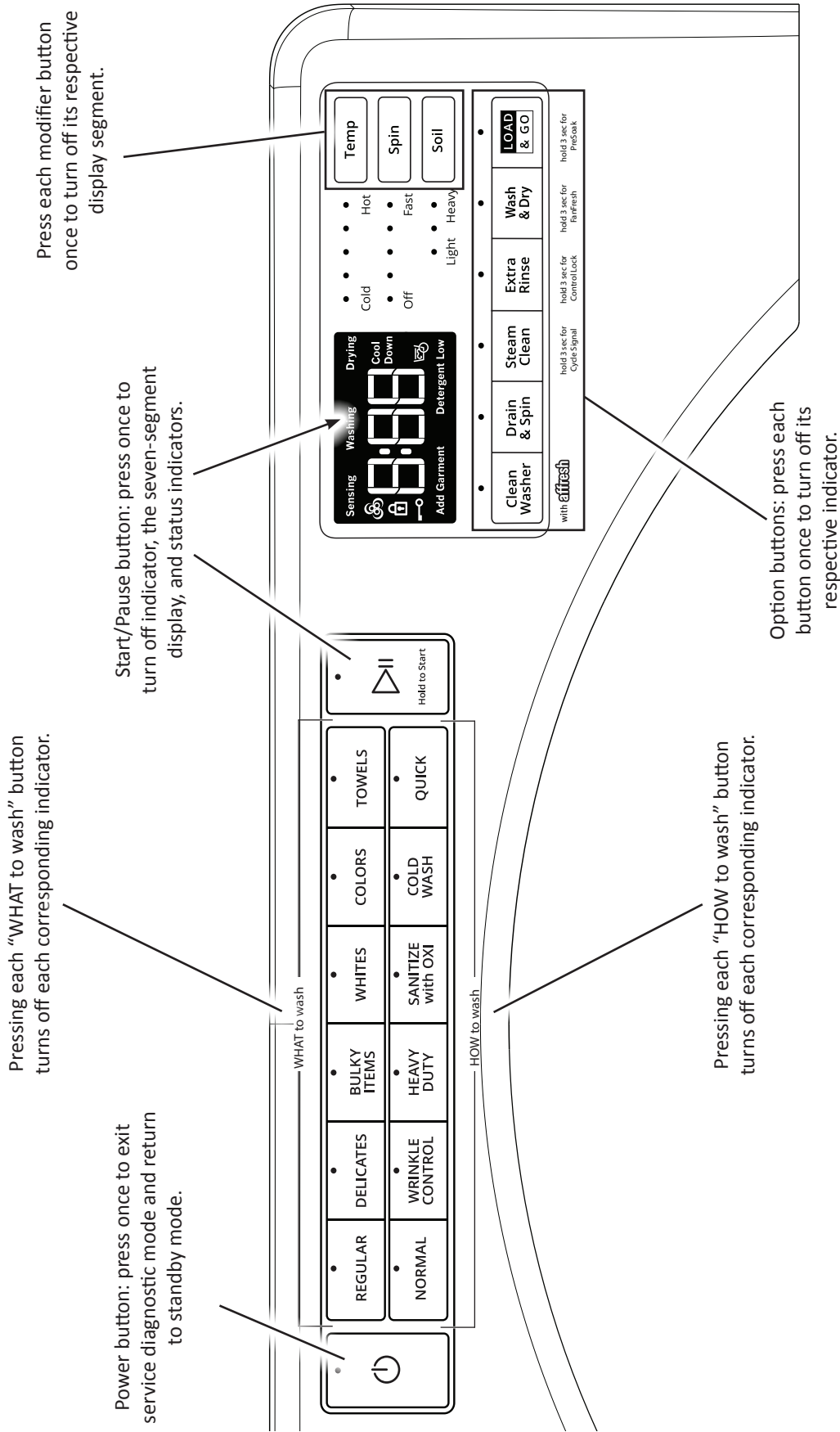

Figure 1 - Whirlpool Control Panel - Console Models

Whirlpool & Maytag Console Diagnostics

MATYAG CONTROL PANEL (features and appearances may vary between models) (buttons to use when entering Service Diagnostic Mode & Tests)

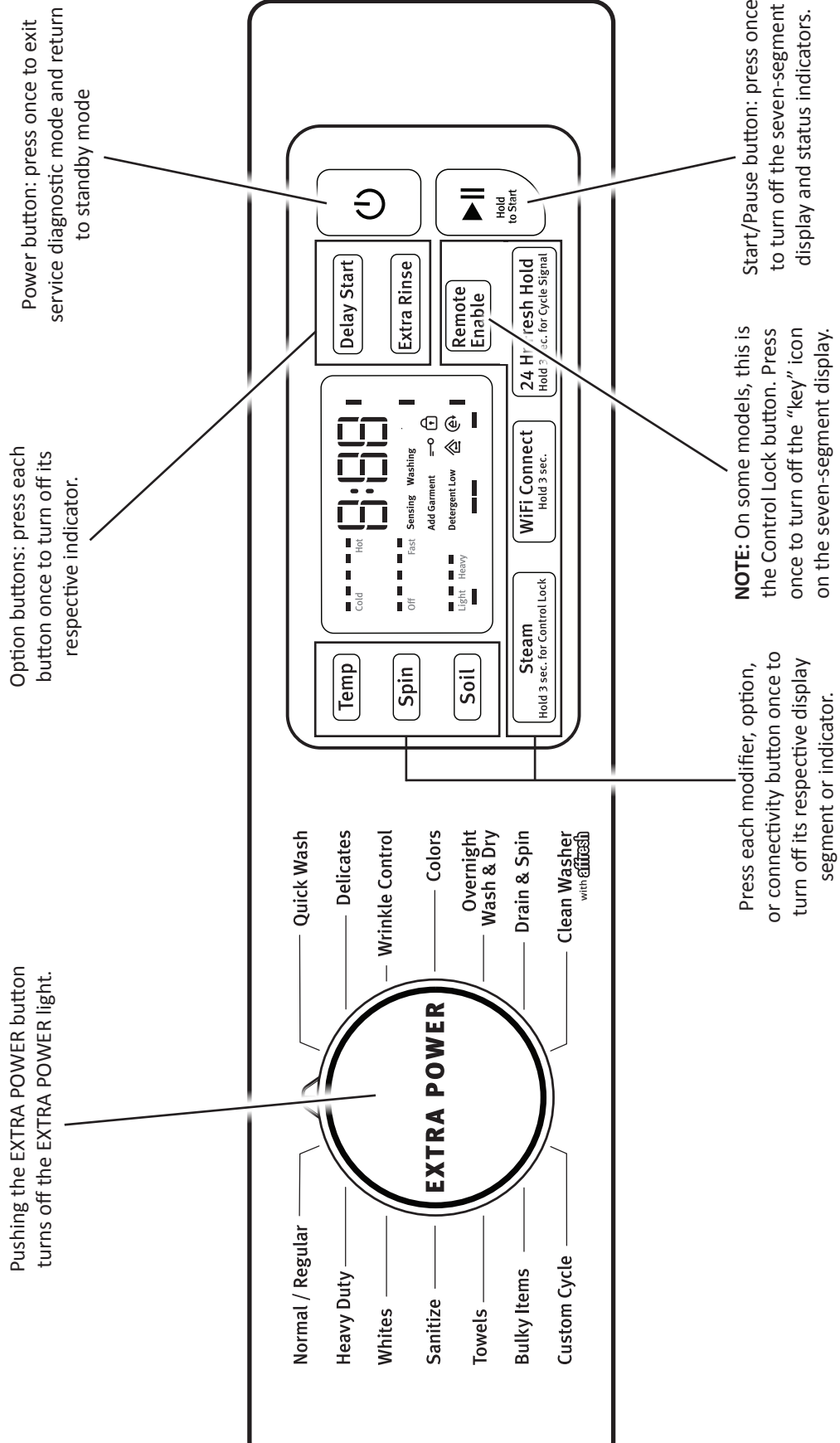

Figure 2 - Maytag Control Panel - Console Models

Whirlpool & Maytag Console Diagnostics

Abbreviations

- ACU:** Appliance Control Unit
- IF:** Interference Filter
- HMI:** Human-Machine Interface

Diagnostic Guide

Before servicing, check the following:

- Make sure there is power at the wall outlet.
- Has a household fuse blown, or circuit breaker or GFCI tripped? Was a regular fuse used? Inform customer that a time-delay fuse is required.
- Are both hot and cold water faucets open and water supply hoses unobstructed?
- Make sure drain hose is not sealed into drain pipe, and that there is an air gap for ventilation.
- Make sure lint build-up is removed from drain pump clean out.
- All tests/checks should be made with a VOM (volt-ohm-milliammeter) or DVM (digital-voltmeter) having a sensitivity of 20,000 Ω per volt DC or greater.
- Resistance checks must be made with washer unplugged or power disconnected.
- **IMPORTANT:** Voltage checks must be made with all connectors attached to the boards.
- **IMPORTANT:** Avoid using large diameter probes when checking harness connectors as the probes may damage the connectors upon insertion.
- Check all harnesses and connections before replacing components. Look for connectors not fully seated, broken or loose wires and terminals, pin insertion, or wires not pressed into connectors far enough to engage metal barbs.
- A potential cause of a control not functioning is corrosion or contamination on connections. Use an ohmmeter to check for continuity across suspected connections.

Service Diagnostic Mode

These tests allow service personnel to test and verify all inputs to the machine control electronics. You may want to do a quick and overall checkup of the washer with these tests before going to specific troubleshooting tests.

Activating Service Diagnostic Mode

1. Be sure the washer is in standby mode (plugged in with all indicators off).
2. After initial power is applied, wait 30 seconds before activating Service Diagnostic mode.
3. Select any three (3) buttons (except POWER) and follow the steps below, using the same buttons. Remember the buttons and the order that the buttons were pressed.

Within 8 seconds,

- Press and Release the **1st** selected button,
 - Press and Release the **2nd** selected button,
 - Press and Release the **3rd** selected button;
 - Repeat this 3 button sequence 2 more times.
4. If the Service Diagnostic mode has been entered successfully, all indicators on the console are illuminated for 5 seconds with “888” showing in the Estimated Time Remaining (Whirlpool) or Estimated Cycle Time (Maytag) seven-segment display. If there are no saved fault codes, all indicators on the console will momentarily turn off, and then only the seven-segment display will come back on and display “888.”

NOTE: The Service Diagnostic mode will time out after 10 minutes of user inactivity, or shut down if AC power is removed.

Activation with Saved Fault Codes

If there is a saved fault code, it will be flashing in the display. Review the Fault/Error Codes beginning on page 2-13 for the recommended procedure and how to display saved error codes. If there is no saved fault code, “888” will be displayed.

| SERVICE DIAGNOSTIC MENU | | |
|-------------------------|--------------------------------|---|
| | BUTTON PRESS | FUNCTION BEHAVIOR |
| 1st Button | • Momentary press | • Activates Human-Machine Interface Test |
| | • Press and hold for 5 seconds | • Exits Service Diagnostic Mode |
| 2nd Button | • Momentary press | • Activates Load Test and Quick Service Cycle |
| | • Press and hold for 5 seconds | • Software Version Display |
| 3rd Button | • Momentary press | • Displays Next Error Code |
| | • Press and hold for 5 seconds | • Clears the Error Codes |

Whirlpool & Maytag Console Diagnostics

Unsuccessful Activation

If entry into Service Diagnostic mode is unsuccessful, refer to the following indication and action:

Indication: None of the indicators or display turn on.

Action: Select any cycle.

- If indicators come on, check the functionality for the three buttons used to activate the Service Diagnostic mode. Verify that the button responds and a beep sound is heard when pressed (make sure button sounds are active). If the button is faulty, it will not be possible to enter the diagnostic mode using that button. Replace the human-machine interface and housing assembly.
- If no indicators come on after selecting the cycle, go to TEST #1, ACU Power Check, page 3-6.

Human-Machine Interface (HMI) Test

(Figures 1 & 2, pages 2-2 & 2-3)

NOTE: The Service Diagnostic mode must be activated before entering the Human-Machine Interface (HMI) Test; see procedure on page 2-4.

Active Fault Code Display in HMI Test

If the display begins flashing while in HMI Test, it is displaying an active fault code. Active fault codes are codes that are currently detected. Only one active fault code can be displayed at a time.

Entry Procedure

Press and release the **1st** button used to activate Service Diagnostic mode. All console indicators turn on and “888” is displayed.

Human-Machine Interface (HMI) Test

Pressing each button will turn off its corresponding indicator(s) or display segment as shown in figures 1 & 2 (pages 2-2 & 2-3).

Maytag Only: Pushing the EXTRA POWER button turns off the EXTRA POWER light.

- If indicators do not turn off after pressing buttons, go to TEST #2B: Human-Machine Interface on page 3-9.

Exit Procedure

To exit HMI Test, press and hold the **1st** button used to activate Service Diagnostic mode for 5 seconds, or press the **POWER** button once or twice.

SOFTWARE VERSION DISPLAY

Entry Procedure

To enter Software Version Display, press and hold the 2nd button used to activate the Service Diagnostic mode for 5 seconds. Upon entry, the display will automatically cycle through the following information:

- ACU firmware revision code (C: major revision number, minor revision number, test revision number)
- Settings file revision code (S: flashes 4 times, each time showing 2 digits of the 8-digit number)
- MCU firmware revision code (n: major revision number, minor revision number, test revision number)
- HMI firmware revision code (U: major revision number, minor revision number, test revision number)
- Touch firmware revision code (t: major revision number, minor revision number, test revision number)

Exit Procedure

To exit Software Version Display, press and hold the **1st** button used to activate Service Diagnostic mode for 5 seconds, or press the **POWER** button.

Whirlpool & Maytag Console Diagnostics

Load Test and Quick Service Cycle

NOTE: The Service Diagnostic mode must be activated before entering the Load Test and Quick Service Cycle; see procedure on page 2-4. If, at any point, the user presses the **POWER** button, the washer exits to standby mode.

Active Fault Code Display in Quick Service Cycle

If the display begins flashing while in the Quick Service Cycle, it is displaying an active fault code. Active fault codes are codes that are currently detected. Only one active fault code can be displayed at a time.

Entry Procedure

To enter the Load Test and Quick Service Cycle, press and release the **2nd** button used to activate the Service Diagnostic mode.

Successful Entry

The seven segment display will show “001” to indicate that the washer is ready to begin.

Load and Quick Test Cycle Selection Procedure

Loads and the Quick Service Cycle are assigned function numbers. These are defined in the chart below.

The seven segment display will indicate the current selected function number.

Use the **Soil** and **Temp** buttons to select a function number. The **Soil** will increment through the function numbers and the **Temp** button will decrement through the function numbers.

Commanding Functions ‘On’ and ‘Off’ in Load Test

With the desired function number on the seven segment display, the function can be turned **ON** by pressing the **START** button. If the selected function is currently active (commanded ‘ON’), the seven segment display will flash the function number at a 1 Hz rate (1 flash per second).

To turn the load **OFF**, press the **POWER** button. The load will turn off and the washer will enter Standby mode. Alternatively, to turn off the current load and turn on another, use the **Soil** or **Temp** button to select another function. The previous function will turn off and the new function will turn on automatically.

The chart below indicates load function and Quick Service Cycle function numbers.

Quick Service Cycle Execution

When the Quick Service Cycle is activated, any functions(s) that were manually commanded ON will be turned OFF. The Quick Service Cycle will start and the seven segment display will flash “012” while the cycle runs (see chart on page 2-7).

NOTE: The drum must be empty during this test.

Exit Procedure

To exit the Load Test and Quick Service Cycle, press the **POWER** button, or press and hold the **1st** button used to activate Service Diagnostic mode for 5 seconds.

Load Test and Quick Service Cycle Function Numbers Chart

NOTE: Some functions will not be available on all models

| Display | Function | Notes | Timeout |
|---------|---|--|----------------------------|
| 001 | Cold 1 Valve | Fills the drum with cold water | 5 min. |
| 002 | Cold 2 Valve | Fills the drum with cold water | 5 min. |
| 003 | Hot Valve | Fills the drum with hot water | 5 min. |
| 004 | Drain Pump | Turns on the drain pump | 5 min. |
| 005 | Recirculation Pump | Turns on the recirculation pump | 5 min. |
| 006 | NA | Pauses the washer | 1 min. |
| 007 | Spin | Drains water (if necessary) Spins the drum at 820 RPM | 5 min. (after draining) |
| 008 | Heater | Adds cold water to the drum Turns on heater | 5 min. (after filling) |
| 009 | NA | Pauses the washer | 1 min. |
| 010 | Detergent Pump | Turns on the detergent pump | 5 min. |
| 011 | NA | Pauses the washer | 1 min. |
| 012 | Quick Service Cycle (see Chart on page 2-7) | See next page | 7-8 min. |

Whirlpool & Maytag Console Diagnostics

Quick Service Cycle Chart

NOTE: Each step may have a brief pause before the load turns on.

NOTE: When the Quick Service Cycle is activated, the seven-segment display will flash "012."

| Step | Washer Function | Recommended Procedure | Est. Duration |
|------------|---|---|---------------|
| 1 | Lock Door | If door does not lock, see TEST #4: Door Lock System, page 3-11. | 10 sec. |
| 2 | Drain (if necessary) | If drain pump does not turn on, see TEST #8: Drain/Recirculation Pump, page 3-15. | 20 sec. |
| 3 | Cold 1 Valve | If no water, see TEST #6: Water Inlet Valves, page 3-13. | 10 sec. |
| 4 | Cold 2 Valve | If no water, see TEST #6: Water Inlet Valves, page 3-13. | 10 sec. |
| 5 | Hot Valve | If no water, see TEST #6: Water Inlet Valves, page 3-13. | 10 sec. |
| 6 | Drain Pump | If drain pump does not turn on, see TEST #8: Drain/Recirculation Pump, page 3-15. | 10 sec. |
| 7 | Recirculation Pump | If recirculation pump does not turn on, see TEST #8: Drain/Recirculation Pump, page 3-15. | 10 sec. |
| 8 | Drain Pump | If drain pump does not turn on, see TEST #8: Drain/Recirculation Pump, page 3-15. | 10 sec. |
| 9 | Spin at 820 RPM | If drum does not spin, see TEST #3: Motor Circuit, page 3-10. | 5 min. |
| 10 | Cold 1 Valve (fill to minimum fill level) | If no water, see TEST #6: Water Inlet Valves, page 3-13. | 30 sec. |
| 11 | Wash Heater | If heater does not turn on, see TEST #9: Wash Heating Element, page 3-16. | 10 sec. |
| 12 | Detergent Pump | If pump does not turn on, see TEST #11B: Optimal Dispense-Dosing Pump, page 3-19. | 10 sec. |
| 13 | Tumble | If drum does not spin, see TEST #3: Motor Circuit, page 3-10. | 22 sec. |
| 14 | End of Cycle | Washer enters Standby Mode - Door Unlocks. | |
| Total Time | | | ~7-8 minutes |

NOTE: After executing the Quick Service Cycle, recheck for new error codes.

Whirlpool & Maytag Console Diagnostics

FAULT/ERROR CODES

(Refer to fault/error code charts beginning on page 2-13.)

Fault/Error Code Display Method

Fault codes are displayed by alternately showing F# and E#. All fault codes have an F# and an E#. The F# indicates the suspect System/Category. The E# indicates the suspect Component system.

Up to ten (10) Fault/Error codes may be stored. When the oldest fault code is displayed, the following press of the **3rd** button will result in a triple beep, then display the most recent fault code. If each press of the **3rd** button results in a triple beep and the display shows "888," no saved fault codes are present.

Entry Procedure

To display the Fault/Error Codes, press and release the **3rd** button used to activate the Service Diagnostic mode.

Clearing Fault Codes

To clear fault codes, enter Service Diagnostic mode. Then press and hold the **3rd** button used to enter Service Diagnostic mode for 5 seconds. Once the fault codes are successfully erased, the seven segment display will show "888."

Exit Procedure

To exit Fault/Error Codes, press and hold the **1st** button used to activate Service Diagnostic mode for 5 seconds.

Advancing Through Saved Fault/Error Codes

Procedure for advancing through saved fault codes:

| | | |
|---|-----------------|--|
| Press and release the 3rd button used to activate Service Diagnostics | ⇒ beep tone ⇒ | most recent fault code is displayed |
| Repeat | ⇒ beep tone ⇒ | second most recent fault code is displayed |
| Repeat | ⇒ beep tone ⇒ | third most recent fault code is displayed |
| Repeat | ⇒ beep tone ⇒ | fourth most recent fault code is displayed |
| Repeat | ⇒ beep tone ⇒ | fifth most recent fault code is displayed |
| . | . | . |
| . | . | . |
| . | . | . |
| . | . | . |
| . | . | . |
| Repeat | ⇒ triple beep ⇒ | no additional fault codes are stored--back to the most recent fault code |

Whirlpool LCD in Door Diagnostics

Figure 1 - LCD Screen in Door

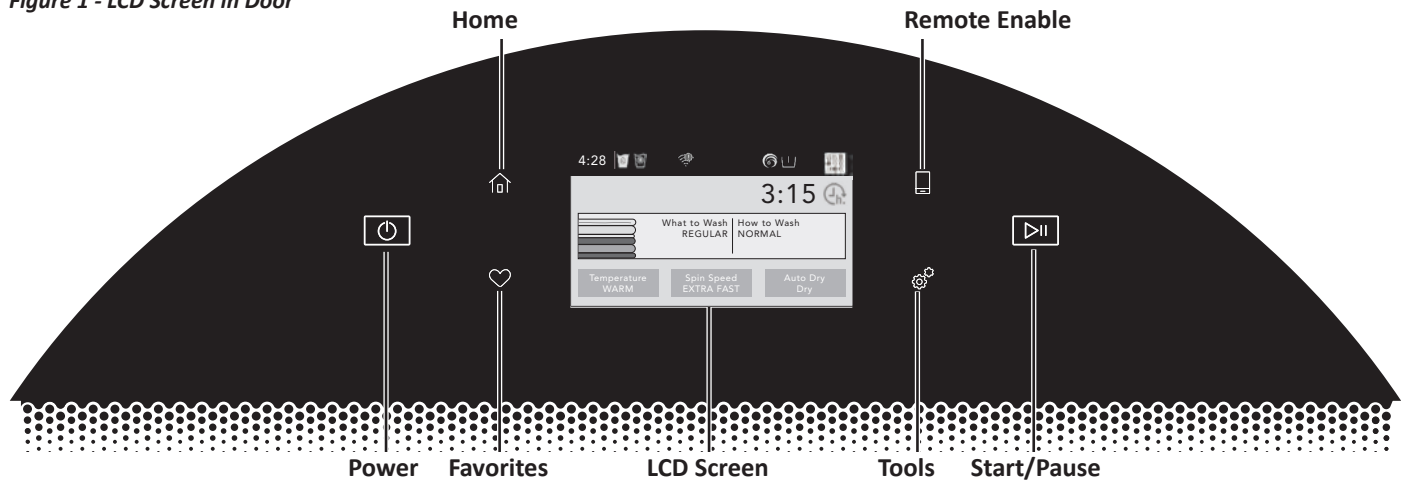

ABBREVIATIONS

ACU: Appliance Control Unit

IF: Interference Filter

HMI: Human-Machine Interface

DIAGNOSTIC GUIDE

Before servicing, check the following:

- Make sure there is power at the wall outlet.
- Has a household fuse blown, or circuit breaker or GFCI tripped? Was a regular fuse used? Inform customer that a time-delay fuse is required.
- Is cold water faucet open and water supply hose unobstructed?
- Make sure drain hose is not sealed into drain pipe, and that there is an air gap for ventilation.
- Make sure lint build-up is removed from drain pump clean out.
- All tests/checks should be made with a VOM (volt-ohm-milliammeter) or DVM (digital-voltmeter) having a sensitivity of 20,000 Ω per volt DC or greater.
- Resistance checks must be made with washer unplugged or power disconnected.
- **IMPORTANT:** Avoid using large diameter probes when checking harness connectors as the probes may damage the connectors upon insertion.
- Check all harnesses and connections before replacing components. Look for connectors not fully seated, broken or loose wires and terminals, pin insertion, or wires not pressed into connectors far enough to engage metal barbs.
- A potential cause of a control not functioning is corrosion or contamination on connections. Use an ohmmeter to check for continuity across suspected connections.
- **IMPORTANT:** Voltage checks must be made with all connectors attached to the boards.

SERVICE DIAGNOSTIC MODE

Allows service personnel to run the Service Test Cycle to verify inputs to the washer and functionality of the washer control. You may want to do a quick and overall checkup of the washer with this test before going to specific troubleshooting tests.

ACTIVATING SERVICE DIAGNOSTIC MODE

IMPORTANT: Use Service Diagnostic Mode without laundry in the washer.

1. Be sure the washer is in standby mode (plugged in with all indicators off).
2. Open and close the washer door.
3. Press the POWER until the washer display turns on. After a few seconds, the home screen will display.
4. Press the **TOOLS** button - 
5. From the TOOLS menu, scroll down to "INFO."
6. From the INFO menu, select "SERVICE & SUPPORT."
7. From the SERVICE INFO screen, Press and hold the **DIAGNOSTICS** button until the "ENTER PASSWORD" screen is displayed.
8. From the ENTER PASSWORD screen, input "123, 123," and press "ENTER."
9. The WARNING DIAGNOSTIC MODE screen will display. Touch **ENTER** to enter diagnostic mode. The **DIAGNOSTIC HOME** screen will be displayed. To continue with the tests in Service Diagnostic Mode, see page 2-10.

Activation with Saved Fault Codes

If there is a saved fault code, the F number will be shown in the display. Review the Fault/Error Codes beginning on page 2-13 for the recommended procedure and how to display saved error codes.

To exit Service Diagnostic Mode, scroll to the top of the DIAGNOSTICS HOME screen, press the "<" button in the top left corner of the screen twice, and then press the **HOME** button.

NOTE: Service Diagnostic Mode times out after 5 minutes of user inactivity.

Exit Procedure

To exit the Service Diagnostic Mode Tests, scroll to the top of the DIAGNOSTICS HOME screen, press the "<" button in the top left corner of the screen twice, and then press the **HOME** button.

Whirlpool LCD in Door Diagnostics

⚠ DANGER



Electrical Shock Hazard
Only authorized technicians should perform diagnostic voltage measurements.
After performing voltage measurements, disconnect power before servicing.
Failure to follow these instructions can result in death or electrical shock.

⚠ WARNING



Electrical Shock Hazard
Disconnect power before servicing.
Replace all parts and panels before operating.
Failure to do so can result in death or electrical shock.

Voltage Measurement Safety Information

When performing live voltage measurements, you must do the following:

- Verify the controls are in the off position so that the appliance does not start when energized.
- Allow enough space to perform the voltage measurements without obstructions.
- Keep other people a safe distance away from the appliance to prevent potential injury.
- Always use the proper testing equipment.
- After voltage measurements, always disconnect power before servicing.

SERVICE DIAGNOSTIC MODE TESTS

NOTE: The Service Diagnostic Mode must be activated before performing the tests; see procedure on page 2-9.

The following section describes components that may be manually turned on and off to help with troubleshooting certain issues.

IMPORTANT: Turn off power or disconnect washer before attaching test leads. Be sure test leads are attached prior to component activation.

To check voltage measurements, the following steps must be followed:

1. Unplug washer or disconnect power.
2. Connect voltage measurement equipment to appropriate connectors.
3. Plug in washer or reconnect power and confirm voltage reading.
4. After performing voltage measurements, unplug washer or disconnect power.

Active Fault Code Display in Quick Service Cycle

If the display begins flashing while running a Quick Service Cycle, it is displaying an active fault code. Active fault codes are codes that are currently being detected. Only one active fault code can be displayed at a time.

From the DIAGNOSTICS HOME screen:

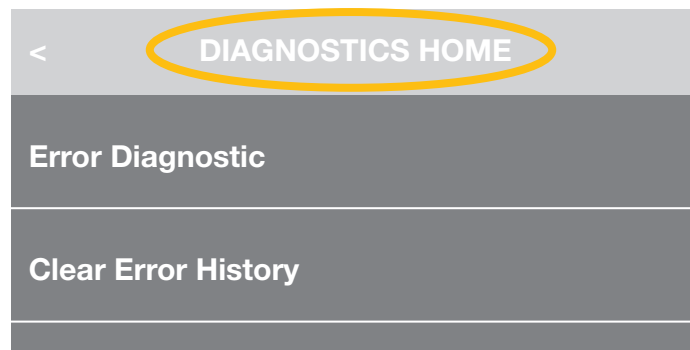

Figure 1

Scroll down and select “Component Activation”

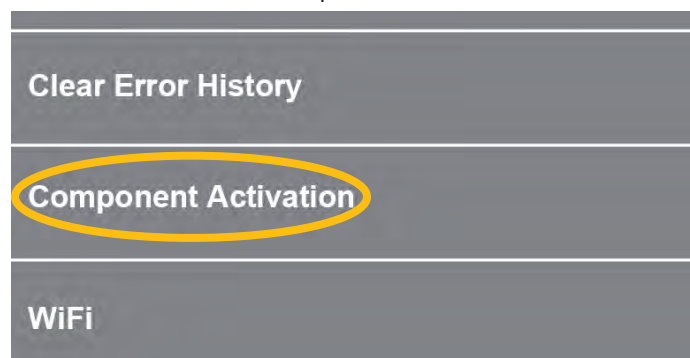

Figure 2

Continued on following page . . .

Whirlpool LCD in Door Diagnostics

SERVICE DIAGNOSTIC MODE TESTS (Continued)

Component Activation

The Component Activation screen includes a list of loads that can be tested. Select the appropriate row and touch once to toggle the load ON, touch again to toggle OFF.

NOTE: The door will lock whenever a load is turned ON. The door will unlock when the load is turned OFF.

Scroll down and select the component as follows:

IMPORTANT: Activate only one component at a time.

- Turn “Cold 1 Valve ON” On – confirm voltage measurement
- Turn “Cold 1 Valve ON” Off
- Turn “Cold 2 Valve ON” On – confirm voltage measurement
- Turn “Cold 2 Valve ON” Off

| Component Activation | |
|------------------------------|-----|
| Activate only one at a time! | |
| Cold 1 Valve ON | Off |
| Cold 2 Valve ON | Off |

Figure 3

- Turn “Hot Valve ON” On – confirm voltage measurement
- Turn “Hot Valve ON” Off
- Turn “Drain Pump” On – confirm voltage measurement
- Turn “Drain Pump” Off
- Turn “Recirculation Pump” On – confirm voltage measurement
- Turn “Recirculation Pump” Off

| | |
|--------------------|-----|
| Hot Valve ON | Off |
| Drain Pump | Off |
| Recirculation Pump | Off |

Figure 4

- Turn “Spin LowSpeed” On – confirm voltage measurement
- Turn “Spin LowSpeed” Off
- Turn “Spin HighSpeed” On – confirm voltage measurement
- Turn “Spin HighSpeed” Off

IMPORTANT: Drum will spin to 830 RPM. Ensure nothing is in the drum.

- Turn “Add min. water level, Turn on Heater” On - confirm voltage measurement (*On Some Models*)
- Turn “Add min. water level, Turn on Heater” Off

IMPORTANT: Washer will add a minimal water level, then turn on the heater.

| | |
|-------------------------------------|-----|
| Spin LowSpeed | Off |
| Spin HighSpeed | Off |
| Add min water level, Turn on Heater | Off |

Figure 5

- Turn “Dry Heater* and Combo Fan” On – confirm voltage measurement
 - Turn “Dry Heater* and Combo Fan” Off
- *IMPORTANT:** The “Dry Heater Element” has been deactivated on the LCD in Door diagnostics. Only the “Fan” will be activated.
- Turn “Detergent Pump” On – confirm voltage measurement
 - Turn “Detergent Pump” Off
 - Turn “Softener Pump” On – confirm voltage measurement
 - Turn “Softener Pump” Off

| | |
|--------------------------|-----|
| Dry Heater and Combo Fan | Off |
| Detergent Pump | Off |
| Softener Pump | Off |

Figure 6

Continued on following page . . .

Whirlpool LCD in Door Diagnostics

SERVICE DIAGNOSTIC MODE TESTS (Continued)

- Turn “Quick Service Cycle 1” On (see table below)
- Turn “Quick Service Cycle 1” Off

Exit Service Diagnostic Mode by scrolling to the top and pressing the < button in the top left corner of the screen twice, and then pressing the HOME button.

| | |
|-----------------------|-----|
| Softener Pump | Off |
| Quick Service Cycle 1 | Off |

Figure 7

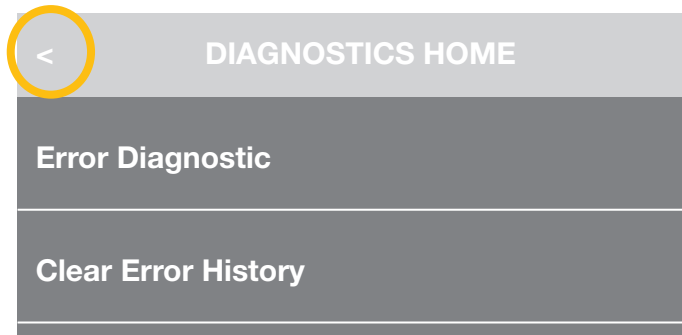

Figure 8

Quick Service Cycle

When the Quick Service Cycle is activated, any functions that were manually commanded ON will be turned OFF. The Quick Service Cycle will run as described in the table below. **NOTE:** The drum must be empty during this test.

| Step | Washer Function | Recommended Procedure | Est. Duration |
|------------|---------------------------------|---|---------------|
| 1 | Lock Door | If door does not lock, see TEST #4: Door Lock System, page 3-11. | 10 sec. |
| 2 | Drain (if necessary) | If drain pump does not turn on, see TEST #8: Drain/Recirculation Pump, page 3-15. | 20 sec. |
| 3 | Cold 1 Valve | If no water, see TEST #6: Water Inlet Valves, page 3-13. | 10 sec. |
| 4 | Cold 2 Valve | If no water, see TEST #6: Water Inlet Valves, page 3-13. | 10 sec. |
| 5 | Hot Valve | If no water, see TEST #6: Water Inlet Valves, page 3-13. | 10 sec. |
| 6 | Drain Pump | If drain pump does not turn on, see TEST #8: Drain/Recirculation Pump, page 3-15. | 10 sec. |
| 7 | Recirculation Pump | If recirculation pump does not turn on, see TEST #8: Drain/Recirculation Pump, page 3-15. | 10 sec. |
| 8 | Drain Pump | If drain pump does not turn on, see TEST #8: Drain/Recirculation Pump, page 3-15. | 10 sec. |
| 9 | Spin at 820 RPM w/Drain Pump ON | If drum does not spin, see TEST #3: Motor Circuit, page 3-10. | 5 min. |
| 10 | Dry Blower | If no airflow, see TEST #17: Dry Blower Motor, page 3-26. | 10 sec. |
| 11 | Detergent Pump | If Detergent Pump does not turn on, see TEST #12A: Drawer Bulk Dispenser, page 3-20. | 10 sec. |
| 12 | Softener Pump | If Softener Pump does not turn on, see TEST #12A: Drawer Bulk Dispenser, page 3-20. | 10 sec. |
| 13 | CW Slow Spin CCW Slow Spin | If drum does not spin, see TEST #3: Motor Circuit, page 3-10. | 22 sec. |
| 14 | End of Cycle | Washer enters Standby Mode - Door Unlocks | |
| Total Time | | | ~7-8 minutes |

Console and LCD Fault Error Codes

⚠ WARNING



Electrical Shock Hazard

Disconnect power before servicing.

Replace all parts and panels before operating.

Failure to do so can result in death or electrical shock.

Fault/Error Code Display Method

Fault codes are displayed by showing F#E#. The F# indicates the suspect System/Category. The E# indicates the suspect Component system.

The fault codes below may be indicated under various conditions and can be accessed through Service Diagnostics.

Fault/Error Code Chart

| Code | Description | Explanation and Recommended Procedure |
|---------------------|---|---|
| FOE1 "rL" | Load detected during Clean Washer cycle | During the cleaning cycle, a load was detected inside the drum. Remove Load and restart the Clean Washer cycle. <ul style="list-style-type: none"> • Load inside the washer during clean cycle. • Mechanical friction on drive mechanism or drum. |
| FOE2 "Sd" | Oversuds | Fault is displayed when the pressure sensor detects rising suds level. The ACU will flush water in an attempt to clear suds. If the water flush is unable to correct the problem, this may indicate: <ul style="list-style-type: none"> • Not using HE detergent. • Excessive detergent usage. • Check pressure hose connection from tub to ACU. Is hose pinched, kinked, plugged, or leaking air? |
| FOE5 "ob" | Off Balance Load | Fault is displayed when an off balance condition is detected. <ul style="list-style-type: none"> • Load unbalanced or too large. • Load is tightly packed in washer. • Washing single items. • Balance single item, such as a rug or jeans, with a few extra items. |
| F1E1 | Appliance Control Unit Fault | Indicates an ACU fault. Try recycling power to washer. <ul style="list-style-type: none"> • See TEST #1: ACU Power Check, pg. 3-6. |
| F1E2 | Appliance Control Unit Fault | Indicates a fault of the motor control section of the ACU. Try recycling power to washer. <ul style="list-style-type: none"> • See TEST #1: ACU Power Check, pg. 3-6. • See TEST #3: Motor Circuit, pg. 3-10. |
| F3E1 | Water Level Sensor Fault | Fault is displayed when the ACU detects an out of range pressure signal. <ul style="list-style-type: none"> • Is the pressure hose connection from the tub to the pressure switch pinched, kinked, plugged, or leaking air? • See TEST #7: Water Level Sensor, pg. 3-14. |
| F3E2 | Wash NTC Fault | Fault is displayed if wash temperature sensor is out of range, or open circuit or short circuit is detected. <ul style="list-style-type: none"> • See TEST #10: Wash Temperature Sensor, pg. 3-17. |
| F3E5 | Dry NTC Fault | Fault is displayed if dry temperature sensor is out of range, or open circuit or short circuit is detected. The wash function is still operable, but the dry function will not operate. <ul style="list-style-type: none"> • See TEST #16: Dry Thermistor Sensor, pg. 3-25. |

Continued on following page . . .

Console and LCD Fault Error Codes

Fault/Error Code Chart (continued)

| Code | Description | Explanation and Recommended Procedure |
|---------------------|--|--|
| F3E6 | Accelerometer Fault | Fault is displayed if the Accelerometer failed self test or experienced orientation error. Replace the Appliance Control Unit (ACU). |
| F4E1 | Wash heater relay error or no feedback signal. | Error is generated when the ACU cannot detect the temperature rise of the wash heater. <ul style="list-style-type: none"> • See TEST #9: Wash Heating Element, pg. 3-16. |
| F4E2 | Heater Not Turning On | Fault is displayed when the heater has not been turned on. <ul style="list-style-type: none"> • Wash heater relay is not closed. • See TEST #9: Wash Heating Element, pg. 3-16. |
| F4E4 | Vent Fan Motor Fault or Dry Blower Motor Fault | Fault is displayed if open circuit or short circuit of Vent Fan or Dry Blower Motor is detected (component fault is based on model tested). <ul style="list-style-type: none"> • See TEST #13: Vent Fan Motor, pg. 3-22. • See TEST #17: Dry Blower Motor, pg. 3-26. |
| F5E1 | Door Switch Fault | Fault is displayed when the following condition occurs: <ul style="list-style-type: none"> • Door switch is open while the door is locked for more than 5 seconds. • See TEST #4: Door Lock System, pg. 3-11. |
| F5E2 | Door Lock Will Not Lock or Door Lock Failure | Fault is displayed when one of the following conditions occur: <ul style="list-style-type: none"> • Door will not close completely due to interference. • ACU detects open door switch when attempting to lock. • ACU cannot determine if door lock is in a locked state. • See TEST #4: Door Lock System, pg. 3-11. |
| F5E3 | Door Unlock Failure | Fault is displayed when one of the following conditions occur: <ul style="list-style-type: none"> • The washer is unable to unlock the door. • ACU cannot determine if door lock is in an unlocked state. • See TEST #4: Door Lock System, pg. 3-11. |
| F5E4 "dr" | Door Not Open Between Cycles | Fault is displayed when one of the following conditions occur: <ul style="list-style-type: none"> • User presses START with door open. • User presses START after a predetermined number of consecutive washer cycles without opening the door. • The ACU cannot detect the door switch opening and closing properly. • See TEST #4: Door Lock System, pg. 3-11. |
| F6E1 | Communication Error: ACU Cannot Hear HMI | Fault is displayed when communications between the HMI and ACU has not been detected. Try recycling power to washer. <ul style="list-style-type: none"> • Verify continuity in cable between ACU (J19) and HMI. See wiring diagram on pages 3-3 to 3-5. • Check AC and DC supplies. See TEST #1 (ACU Power Check) on page 3-6. • See TEST #2A & 2B: Human Machine Interface on pages 3-8 & 3-9. |
| F6E2 | Communication Error: HMI Cannot Hear ACU | Fault is displayed when communications between the HMI and ACU has not been detected. Try recycling power to washer. <ul style="list-style-type: none"> • Verify continuity in cable between ACU (J19) and HMI. See wiring diagram on pages 3-3 to 3-5. • Check AC and DC supplies. See TEST #1 (ACU Power Check) on page 3-6. • See TEST #2A & 2B: Human Machine Interface on pages 3-8 & 3-9. |
| F6E3 | No Communication between ACU and MCU. | Fault is displayed when communications between the ACU and Motor Controller has not been detected. Try recycling power to washer. <ul style="list-style-type: none"> • Check AC and DC supplies. See TEST #1 (ACU Power Check) on page 3-6. • See TEST #3: Motor Circuit, pg. 3-10. |

Continued on following page . . .

Console and LCD Fault Error Codes

Fault/Error Code Chart (continued)

| Code | Description | Explanation and Recommended Procedure |
|-----------------------------------|------------------------------------|---|
| F7E2 | Motor Control/Internal Fault | <p>Fault is displayed when the ACU has detected a problem with the motor. Try recycling power to washer.</p> <ul style="list-style-type: none"> • Check harness continuity and connections between ACU and motor. • Check AC and DC supplies. See TEST #1 (ACU Power Check) on page 3-6. • See TEST #3: Motor Circuit, pg. 3-10. |
| F7E8 | Motor Control/Over Temp Detected | <p>Fault is displayed when the ACU has detected a problem with the motor. Try recycling power to washer.</p> <ul style="list-style-type: none"> • Check harness continuity and connections between ACU and motor. • Check AC and DC supplies. See TEST #1 (ACU Power Check) on page 3-6. • See TEST #3: Motor Circuit, pg. 3-10. |
| F7E9 | Motor Locked Rotor | See TEST #3: Motor Circuit, pg. 3-10. |
| F7EA or F7E10 | Motor Control/Lost Phase Fault | <p>Fault is displayed when the ACU has detected a problem with the motor. Try recycling power to washer.</p> <ul style="list-style-type: none"> • Check harness continuity and connections between ACU and motor. • Check AC and DC supplies. See TEST #1 (ACU Power Check) on page 3-6. • See TEST #3: Motor Circuit, pg. 3-10. |
| F7EC or F7E12 | Motor Control/Motor Overload Fault | <p>Fault is displayed when the ACU has detected a problem with the motor. Try recycling power to washer.</p> <ul style="list-style-type: none"> • Check harness continuity and connections between ACU and motor. • Check AC and DC supplies. See TEST #1 (ACU Power Check) on page 3-6. • See TEST #3: Motor Circuit, pg. 3-10. |
| F8E1 “Lo” “FL” | Long Fill | <p>Fault is displayed when the water level does not change for a period of time OR water is present, but the ACU does not detect the water level changing.</p> <ul style="list-style-type: none"> • Is water supply connected and turned on? • Are water supply hoses kinked? • Are hose screens plugged? • Low water pressure; fill times longer than 10 minutes. • Is the pressure hose connection from the tub to the pressure switch pinched, kinked, plugged, or leaking air? • See TEST #6: Water Inlet Valves, pg. 3-13. |
| F8E3 | Overflow | <p>Make sure drain hose and drain pump filter are not plugged. Verify functionality of water inlet valve, water level sensor, and drain/recirculation pump.</p> <ul style="list-style-type: none"> • See TEST #6: Water Inlet Valves, pg. 3-13. • See TEST #7: Water Level Sensor, pg. 3-14. • See TEST #8: Drain/Recirculation Pump, pg. 3-15. |
| F9E1 | Long Drain | <p>Fault is displayed when the water level sensor does not change after the drain pump is on.</p> <ul style="list-style-type: none"> • Check drain hose installation for proper height. • Check drain hose and filter for obstructions, and make sure drain hose is not sealed into drain pipe. • Is the pressure hose connection from the tub to the pressure switch pinched, kinked, plugged, or leaking air? • Check functionality of drain/recirculation pump. • See TEST #8: Drain/Recirculation Pump, pg. 3-15. |
| FCE0 | WiFi Error | HMI cannot communicate with the WiFi module. See Section 5 - Connectivity |

Console and LCD Troubleshooting Guide

⚠ WARNING



Electrical Shock Hazard

Disconnect power before servicing.

Replace all parts and panels before operating.

Failure to do so can result in death or electrical shock.

TROUBLESHOOTING GUIDE

NOTE: Always check for error/fault codes first (pages 2-13 through 2-15)

Some tests will require accessing components. See Section 4, “Component Access” for component locations. For detailed testing procedures, refer to Section 3, “Component Testing.”

| Problem | Possible Cause | Checks & Tests |
|--|---|--|
| Won't Power Up <ul style="list-style-type: none"> • No operation • No keypad response • No LED's or display | No power to washer. | Check power at outlet, check circuit breakers, fuses, or junction box connections. |
| | Connection problem between AC plug and ACU. | Check connections between the AC power cord and ACU for continuity. |
| | Connections between ACU and HMI. | Check connections and harness continuity between the ACU and HMI. |
| | ACU problem. | See TEST #1: ACU Power Check, page 3-6. |
| | HMI problem. | See TEST #2A & 2B: Human-Machine Interface, pgs. 3-8 & 3-9. |
| Won't Start Cycle No response when START is pressed Important: Starting a cycle requires “Press and hold” of START button | Control lock is activated. | Check if the control lock LED/icon is on. If so, press and hold to deactivate it. |
| | Three consecutive cycles were run without opening the door. | Open and close the door before starting the cycle. |
| | Door lock mechanism not functioning. | 1. Door not closed due to interference. 2. Lock not closed due to interference. 3. See TEST #4: Door Lock System, page 3-11. |
| | Connections between ACU and HMI. | Check connections and harness continuity between ACU and HMI. |
| | HMI problem. | See TEST #2A & 2B: Human-Machine Interface, pgs. 3-8 & 3-9. |
| ACU problem. | See TEST #1: ACU Power Check, page 3-6. | |
| HMI Won't Accept Selections | Control lock is activated. | Check if the control lock LED/icon is on. If so, press and hold to deactivate it. |
| | Connections between ACU and HMI. | Check connections and harness continuity between ACU and HMI. |
| | HMI problem. | See TEST #2A & 2B: Human-Machine Interface, pgs. 3-8 & 3-9. |
| | ACU problem. | See TEST #1: ACU Power Check, page 3-6. |
| Door Won't Lock | Door not closed. | Ensure that door is completely closed. |
| | Door lock obstructed. | Check mechanism for obstruction. |
| | Door lock mechanism not functioning. | See TEST #4: Door Lock System, page 3-11. |

Continued on following page . . .

Console and LCD Troubleshooting Guide

TROUBLESHOOTING GUIDE (continued)

| Problem | Possible Cause | Checks & Tests |
|--|---|---|
| Door Won't Unlock (See page 2-2 for manually unlocking the door lock system.) | Reset washer. | Unplug and reconnect the power cord. Wait 2 minutes to see if the washer door unlocks. |
| | Misaligned, broken, or over-tightened door latch. | Check door lock mechanism and repair as necessary. |
| | Door lock mechanism not functioning. | See TEST #4: Door Lock System, page 3-11. |
| Won't Dispense | No water supplied to washer. | 1. Check water connections to washer. 2. Verify that hot and cold water supply is turned on. |
| | Dispenser clogged with detergent. | Clean obstruction from dispenser. |
| | Valve problem. | See TEST #6: Water Inlet Valves, page 3-13. |
| | Dispenser system problem. | See TEST #11A: Single Dose Dispenser, page 3-18. |
| Won't Fill (Normal water level is only 2.5" to 5" [63.5mm to 127mm] inside tub.) | No water supplied to washer or low water pressure. | 1. Check water connections to washer. 2. Verify that hot and cold water supply is turned on. |
| | Plugged filter/screen, or plugged air trap. | Check for plugged filter or screen in the inlet valves or hoses. Check for air trap obstructions. |
| | Drain hose installation. | Check for proper drain hose installation. Is water siphoning out of the drain hose? |
| | Valve problem. | See TEST #6: Water Inlet Valves, page 3-13. |
| | Water level sensor problem. | See TEST #7: Water Level Sensor, page 3-14. |
| Overfills | Drain hose/filter or air trap is plugged. | Check for hose, drain filter, and air trap obstructions. |
| | Valve(s) not shutting off. | See TEST #6: Water Inlet Valves, page 3-13. |
| | Water level sensor problem. | See TEST #7: Water Level Sensor, page 3-14. |
| | Drain/recirculation pump problem. | See TEST #8: Drain/Recirculation Pump, page 3-15. |
| Drum Won't Rotate | Door is not locked. Is door locking after starting a cycle? | Verify harness connections and see TEST #4: Door Lock System, page 3-11. |
| | Garment or mechanical obstruction between drum and tub. | Try to move the drum while the washer is unpowered to see if it can move freely. If not, check for a garment or other object obstructing movement. |
| | Harness connections. | Check harness continuity and connections between ACU and motor. |
| | Motor problem. | See TEST #3: Motor Circuit, page 3-10. |
| Motor Overheats | Mechanical friction. | Check for obstruction between drum and outer tub. |
| | Harness connections. | Check harness continuity and connections between ACU and motor. |
| | Motor problem. | See TEST #3: Motor Circuit, page 3-10. |
| Won't Drain | Drain hose installation. | Check for proper drain hose installation. Make sure drain hose is not inserted more than 4.5" (114 mm). Make sure drain hose is not sealed into drain pipe, and that there is an air gap for ventilation. |
| | Plugged drain hose or air trap. | Check drain hose and air trap for obstructions. |
| | Obstructions to drain pump. | Check and clean drain filter of obstructions. |
| | Harness connections. | Check harness continuity and connections between ACU and drain pump. |
| | Drain/recirculation pump problem. | See TEST #8: Drain/Recirculation Pump, page 3-15. |
| No Button Sound | Button sound has been deactivated. | See TEST #2A & 2B: Human-Machine Interface, pgs. 3-8 & 3-9. |

Continued on following page . . .

Console and LCD Troubleshooting Guide

TROUBLESHOOTING GUIDE (continued)

| Problem | Possible Cause | Checks & Tests |
|---|---|---|
| Incorrect Water Temperature | Water hose installation. | Make sure inlet hoses are connected properly and that valves are turned on fully. The hot and cold valves on the washer are labeled. |
| | No hot water dispensed. | Ensure that household hot water is present at the tap. Minimum 120°F (49°C). |
| | Heating element problem. | See TEST #9: Wash Heating Element, page 3-16. |
| | Temperature sensor problem. | See TEST #10: Wash Temperature Sensor, page 3-17. |
| Clean Washer LED Flashing at End of Wash Cycle | The washer has run 30 wash cycles and is indicating a reminder to execute the Clean Washer cycle. | Run the Clean Washer cycle. If not, the "Clean Washer" LED will stop flashing at the end of a wash cycle after running 3 more regular wash cycles. After 30 more wash cycles are completed, the "Clean Washer" LED will again flash at the end of a wash cycle, reminding the customer to run a Clean Washer cycle. |
| Drum Light Does Not Turn On (on some models) | Door switch problem. | See TEST #4: Door Lock System, page 3-11. |
| | Harness connections. | Check harness continuity and connections between HMI and drum light. |
| | Drum light problem. | See TEST #5: Drum Light, page 3-12. |
| Leaking | Supply hose connection. | Check hose connections and for damage to rubber gasket due to over-tightening. |
| | Drain hose installation. | Check for proper drain hose installation. |
| | Plugged drain hose or house drain pipe. | Check drain hose for obstructions and make sure house drain pipe is not blocked. |
| | Overloading the washer. | Overloading can partially push the door open. |
| | Internal hose connections. | Check internal hose connections for leakage. |
| | Check bellows. | Check for holes in the bellows. If there are none, remove, reposition, and reinstall the bellows. Make sure the bellows is not wrinkled. |
| | Dispenser leaking. | Check the dispenser for leakage from the front and from the plastic box itself. |
| | Ventilation tube leaking. | Make sure that the ventilation tube connected to the rear of the tub is installed properly. |
| | Heater leaking. | Make sure heater is seated and torqued down to 4.5Nm ± 0.5Nm. |
| Vibration or Noise | Heater is loose. | Make sure heater is torqued down to 4.5Nm ± 0.5Nm. |
| | Shipping kit not removed. | Verify that shipping bolts and spacers are removed. |
| | Washer not level. | Level washer per installation instructions. |
| | Floor stability. | Weak floors can cause vibration and walking of the washer. |
| | Leveling lock nuts not tightened. | Tighten leveling lock nuts. |
| | Clogged inlet screens making high-pitched noise. | Disconnect hoses and clean screens. |
| | Spring/damper installation. | Check for proper spring and damper placement and installation. |
| | Washer panel noise. | Inspect washer panels for bending, warpage, or damage. Check for loose fasteners. |
| | Ventilation hose becoming disconnected. | Verify connection of ventilation hose to the tub and to the back bracket. |
| | Water level sensor hose slapping on the tub. | Make sure the hose is fastened properly. |

Continued on following page . . .

Console and LCD Troubleshooting Guide

TROUBLESHOOTING GUIDE (continued)

| Problem | Possible Cause | Checks & Tests |
|---|--------------------------------------|---|
| Poor Wash Performance Please reference Use & Care Guide | Oversuds. | 1. Verify use of HE detergent. 2. Excessive detergent usage. 3. Check drain hose and filter for obstructions. |
| | Incorrect water level. | See "WON'T FILL", page 2-17. |
| | Clothes wet after cycle is complete. | 1. Single or tangled items in the washer. 2. Oversuds (see above). 3. See "WON'T DRAIN", page 2-17. |
| | Load not rinsed. | 1. Check proper water supply. 2. Not using HE detergent. 3. Verify that load is not bunched or bundled when placed in washer. 4. See TEST #6: Water Inlet Valves, page 3-13. |
| | Not cleaning clothes. | 1. Verify that load is not bunched or bundled when placed in washer. 2. Not using HE detergent. 3. Not using correct cycle. 4. Not using dispensers. |
| | Fabric damage. | 1. Washer overloaded. 2. Bleach was added incorrectly (directly into the tub rather than through the dispenser). 3. Sharp items in tub. |
| | Wrong option or cycle selection. | Refer customer to "Use & Care Guide". |

Manually Unlocking the Door

| |
|---|
| ⚠ WARNING |
|  |
| <p style="text-align: center;">Electrical Shock Hazard</p> <p>Disconnect power before servicing.</p> <p>Replace all parts and panels before operating.</p> <p>Failure to do so can result in death or electrical shock.</p> |

How to Manually Open the Door

Before removing the top of the washer as described below, refer to the failure “Door will not unlock” in the “Troubleshooting” section. The door may unlock by itself after the failure condition no longer exists.

If the door still cannot be opened, perform the following:

Before Opening Door:

- Turn off and unplug the washer.
- Close the water faucets.
- Wait until the drum has stopped rotating – never open the door while the drum is in motion.
- Wait until water and laundry have cooled down when washing with high temperatures.

Always drain the water before opening the door by:

- Following the instructions in the “Cleaning the Drain Pump Filter/Draining Residual Water” section.

To Unlock and Open Washer Door:

1. Remove the top of the washer by removing the three 1/4” hex-head screws in the back. Slide top back and up (see Figure 1).

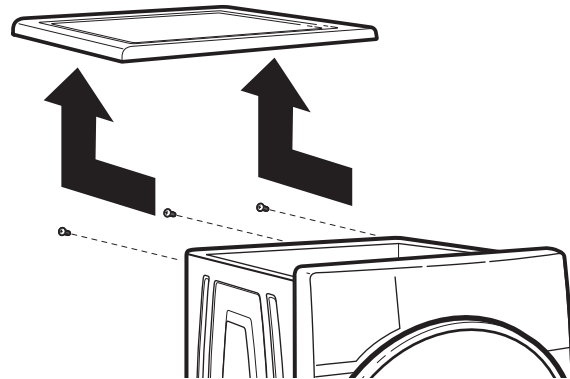

Figure 1

2. Locate the locking mechanism (Figure 2) on the right-hand side of the washer interior about half-way down. Press down on locking mechanism until the latch is released. The door can now be opened and the laundry removed, if needed.

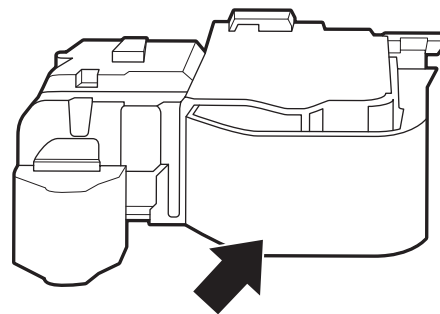

Figure 2

Section 3:

Component Testing

This section provides wiring diagrams, control board specifications, testing procedures and strip circuits for the “Whirlpool & Maytag Front-Load Washers.”

- Testing: Safety Information
- Wiring Diagram - Whirlpool Washer, LCD in Door Models
- Wiring Diagram - Whirlpool Washer, Console Models
- Wiring Diagram - Maytag Washer, Console Models
- Component Testing
- TEST #1: ACU Power Check
- TEST #2A: Human-Machine Interface (LCD Model)
- TEST #2B: Human-Machine Interface (Console Model)
- TEST #3: Motor Circuit
- TEST #4: Door Lock System
- TEST #5: Drum Light
- TEST #6: Water Inlet Valves
- TEST #7: Water Level Sensor
- TEST #8: Drain/Recirculation Pump
- TEST #9: Wash Heater Element
- TEST #10: Wash Temperature Sensor
- TEST #11A: Single Dose Dispenser
- TEST #11B: Optimal Dispense - Dosing Pump
- TEST #12A: Drawer Bulk Dispenser
- TEST #12B: Drawer Bulk Dispenser Level Sensing
- TEST #13: Vent Fan Motor
- TEST #14: Vent Baffle Solenoid
- TEST #15: Dry Heating Element
- TEST #16: Dry Temperature Sensor
- TEST #17: Dry Blower Motor

For Service Technician Use Only

⚠ DANGER



Electrical Shock Hazard

Only authorized technicians should perform diagnostic voltage measurements.

After performing voltage measurements, disconnect power before servicing.

Failure to follow these instructions can result in death or electrical shock.

⚠ WARNING



Electrical Shock Hazard

Disconnect power before servicing.

Replace all parts and panels before operating.

Failure to do so can result in death or electrical shock.

Voltage Measurement Safety Information

When performing live voltage measurements, you must do the following:

- Verify the controls are in the off position so that the appliance does not start when energized.
- Allow enough space to perform the voltage measurements without obstructions.
- Keep other people a safe distance away from the appliance to prevent potential injury.
- Always use the proper testing equipment.
- After voltage measurements, always disconnect power before servicing.

IMPORTANT: Electrostatic Discharge (ESD) Sensitive Electronics

ESD problems are present everywhere. Most people begin to feel an ESD discharge at approximately 3000V. It takes as little as 10V to destroy, damage, or weaken the main control assembly. The new main control assembly may appear to work well after repair is finished, but a malfunction may occur at a later date due to ESD stress.

- Use an anti-static wrist strap. Connect wrist strap to green ground connection point or unpainted metal in the appliance

-OR-

- Touch your finger repeatedly to a green ground connection point or unpainted metal in the appliance.
- Before removing the part from its package, touch the anti-static bag to a green ground connection point or unpainted metal in the appliance.
- Avoid touching electronic parts or terminal contacts; handle electronic control assembly by edges only.
- When repackaging main control assembly in anti-static bag, observe above instructions.

IMPORTANT SAFETY NOTICE — “For Technicians only”

This service data sheet is intended for use by persons having electrical, electronic, and mechanical experience and knowledge at a level generally considered acceptable in the appliance repair trade. Any attempt to repair a major appliance may result in personal injury and property damage. The manufacturer or seller cannot be responsible, nor assume any liability for injury or damage of any kind arising from the use of this data sheet.

For Service Technician Use Only

Wiring Diagram — Whirlpool Washer, LCD in Door Models

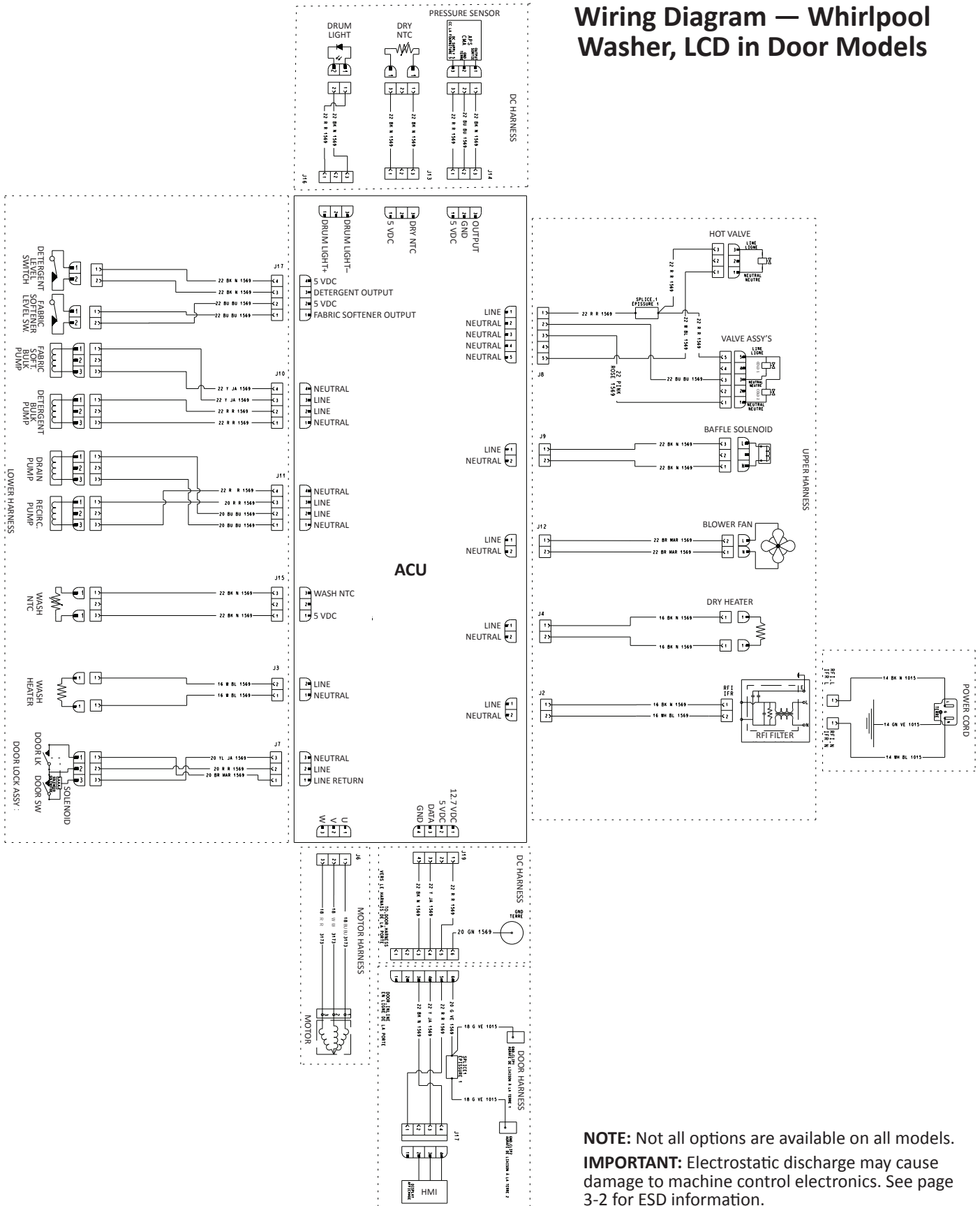

NOTE: Not all options are available on all models.
IMPORTANT: Electrostatic discharge may cause damage to machine control electronics. See page 3-2 for ESD information.

For Service Technician Use Only

Wiring Diagram — Whirlpool Washer, Console Models

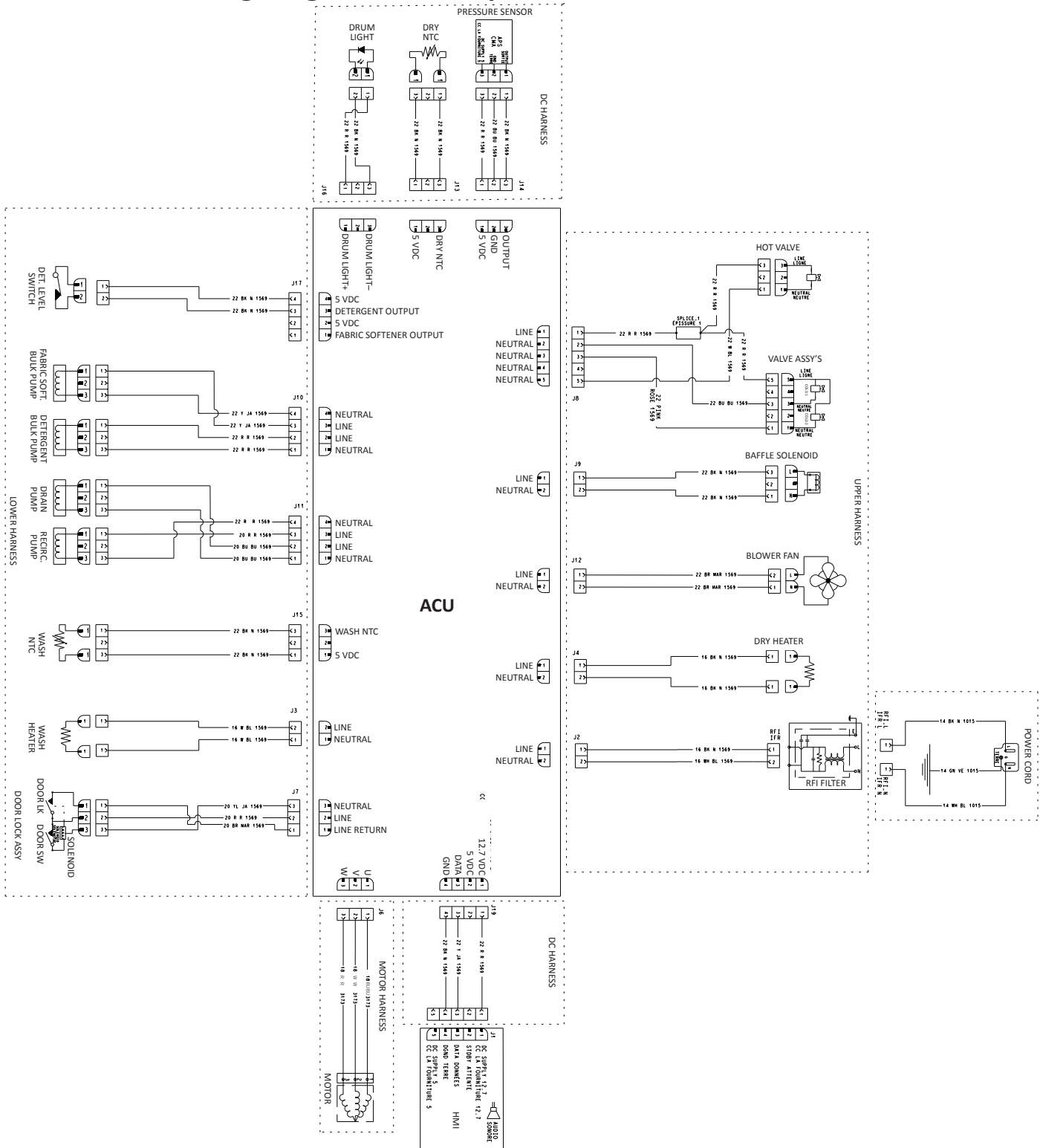

NOTE: Not all options are available on all models.
IMPORTANT: Electrostatic discharge may cause damage to machine control electronics. See page 3-2 for ESD information.

For Service Technician Use Only

Wiring Diagram — Maytag Washer, Console Models

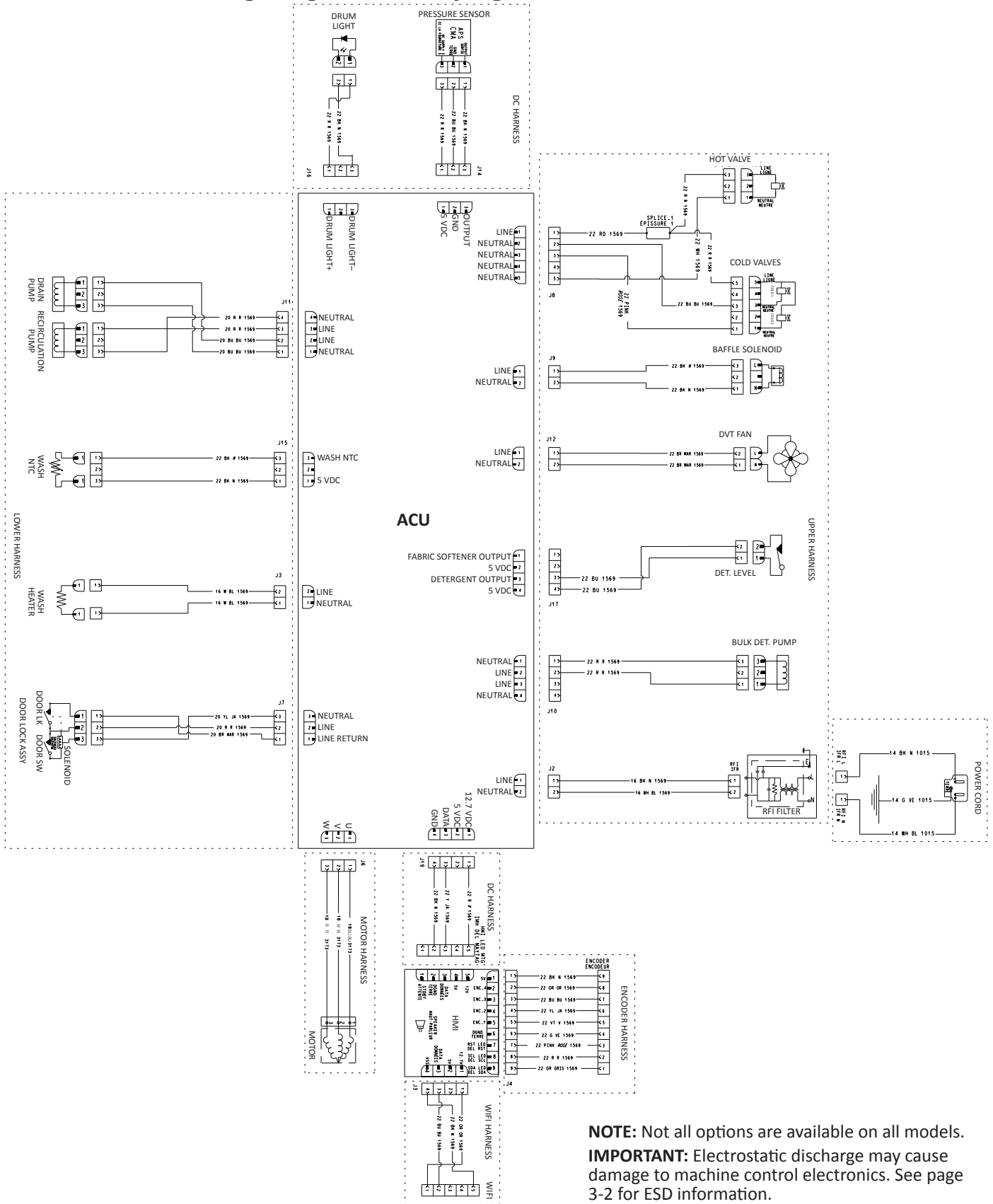

NOTE: Not all options are available on all models.
IMPORTANT: Electrostatic discharge may cause damage to machine control electronics. See page 3-2 for ESD information.

For Service Technician Use Only

⚠ DANGER



Electrical Shock Hazard

Only authorized technicians should perform diagnostic voltage measurements.

After performing voltage measurements, disconnect power before servicing.

Failure to follow these instructions can result in death or electrical shock.

TEST #1: ACU Power Check

This test checks for incoming and outgoing power to and from Appliance Control Unit (ACU). This test assumes that proper voltage is present at the outlet.

1. Unplug washer or disconnect power.
2. Remove top panel to access the machine electronics.
3. Visually check that all connections to the interference filter (IF) are securely connected. See Figure 1, below.
4. Visually check that all connections to the ACU are fully inserted. See Figure 2, page 3-7.
5. If both visual checks pass, go to step 6.
6. Plug in washer or reconnect power.
7. With a voltmeter set to AC, check for line voltage at the input of the interference filter. See Figure 1 below.
 - If line voltage is present, go to step 8.
 - If line voltage is not present, verify the continuity of the power cord. If it fails the continuity check, replace the power cord.
8. With a voltmeter set to AC, check for line voltage at the output filter. See Figure 1 below.
 - If line voltage is present, go to step 9.
 - If line voltage is not present, replace the interference filter.
9. With a voltmeter set to AC, check for input line voltage to the ACU across pins 1 and 2 of connector **J2 AC In** (IF filter). See Figure 2, page 3-7.
 - If line voltage is present, go to step 10.
 - If line voltage is not present, check harnesses and connections between the filter and the ACU. Visually inspect inside connector housing for bent or damaged terminals. Repair as necessary.

10. Service LED/DC Supply

The ACU is equipped with a status LED. This LED indicates the health of the ACU. After the ACU is plugged in, the LED will blink rapidly for a few seconds, then will blink slowly (0.5s on, 0.5s off). This LED indicates the functionality of the microcontroller and power supply:

- If the LED is not lit, there is not 5 volts DC supply to the microcontroller. Replace the ACU.
- If the LED is not blinking slowly within 30 seconds of being power up, the microcontroller is not responding. Replace the ACU.
- If the LED is blinking slowly (0.5s on, 0.5s off) during washer operation, the ACU is probably OK and the problem is elsewhere.

Check HMI input voltage:

Verify that there is 5 VDC between pins 2 and 4 at **J19**.

Verify that there is 12 VDC between pins 1 and 4 at **J19**.

11. Unplug washer or disconnect power.
12. Reassemble all parts and panels.
13. Perform the "Quick Service Cycle" on page 2-7 (console models), or page 2-12 (LCD models) to verify repairs.

Component Testing

TESTING WASHER COMPONENTS FROM THE CONTROL

Before testing any of the components, perform the following checks:

- The most common cause for misdiagnosed control failure is poor connections. Therefore, disconnecting, inspecting and reconnecting wires will be necessary throughout test procedures.
- All tests/checks should be made with a VOM or DVM having a sensitivity of 20,000 ohms-per-volt DC, or greater.
- Check all connections before replacing components, looking for broken or loose wires, failed terminals, or wires not pressed into connectors far enough.
- **IMPORTANT:** Voltage checks must be made with all connectors attached to the boards.
- **IMPORTANT:** Resistance checks must be made with power cord unplugged or power disconnected, and with wiring harness or connectors disconnected from the control.
- **IMPORTANT:** The following procedures may require the use of needle probes to measure voltage. Failure to use needle probes will damage the connectors.

RFI FILTER - Figure 1

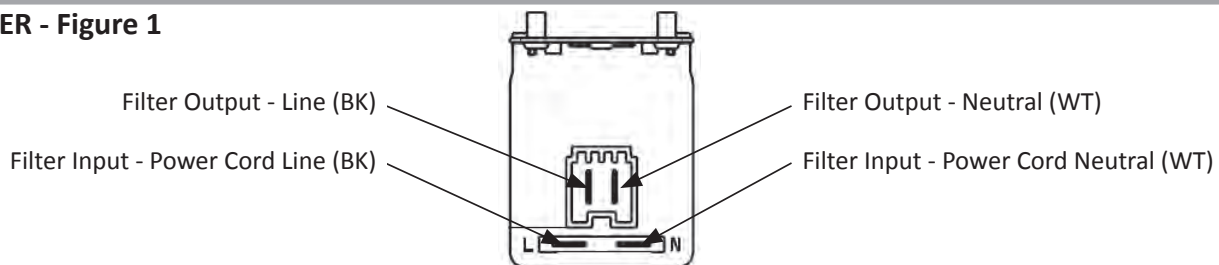

For Service Technician Use Only

ACU CONNECTORS & PINOUTS - FIGURE 2

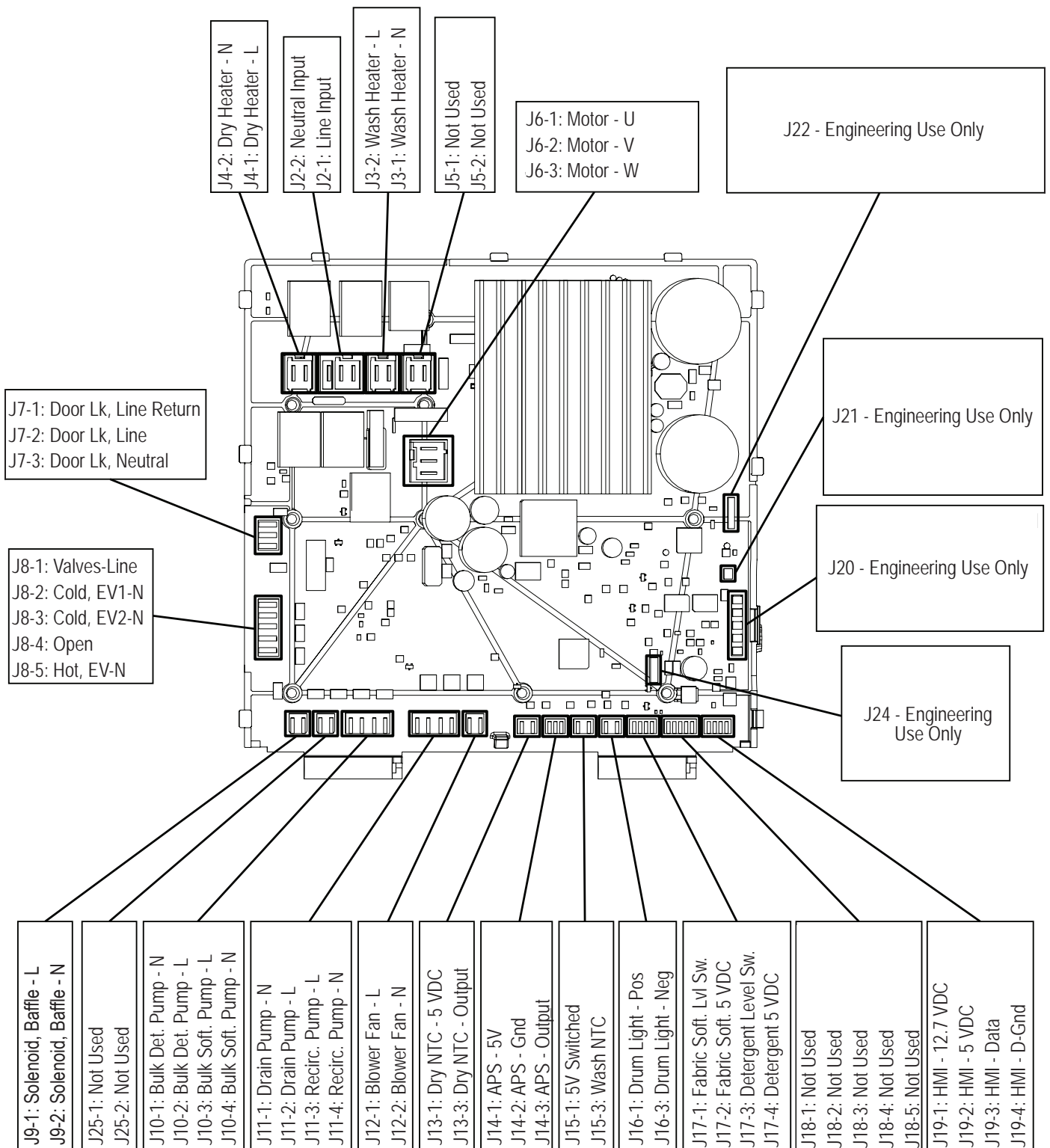

NOTE: Not all options are available on all models.

IMPORTANT: Electrostatic discharge may cause damage to Appliance Control Unit (ACU). See page 3-2 for ESD information.

For Service Technician Use Only

⚠ **WARNING**



Electrical Shock Hazard

Disconnect power before servicing.

Replace all parts and panels before operating.

Failure to do so can result in death or electrical shock.

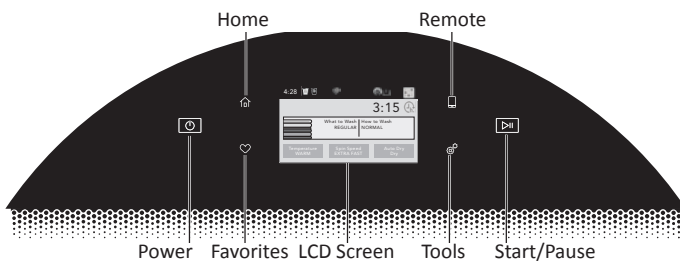

Figure 1 - LCD Screen in Door

TEST #2A: Human-Machine Interface (HMI) “LCD in Door Models”

This test is performed when any of the following situations occurs during the Service Diagnostic Mode Tests (see page 2-9): display does not turn on and/or no sound is heard.

1. Unplug washer or disconnect power.
2. Remove the top to access the ACU.
3. Visually check that all ACU connectors are inserted all the way into the ACU. See Figure 2, page 3-7.
4. Visually check that all HMI connectors are inserted all the way into the HMI (see Figure 2 below).
5. Remove door hinge cover and visually check that the door harness is fully connected.
6. If all visual checks pass, perform TEST #1: ACU Power Check, page 3-6, to verify supply voltage and health of micro-controller.
 - If supply voltages are present and micro-controller is functioning properly, replace the HMI and housing assembly.
 - If supply voltages are not present, replace the ACU.
7. Reassemble all parts and panels.
8. Plug in washer or reconnect power.
9. Perform the “Human-Machine Interface (HMI) Test” (see page 2-5) to verify repair.

HUMAN-MACHINE INTERFACE (HMI)

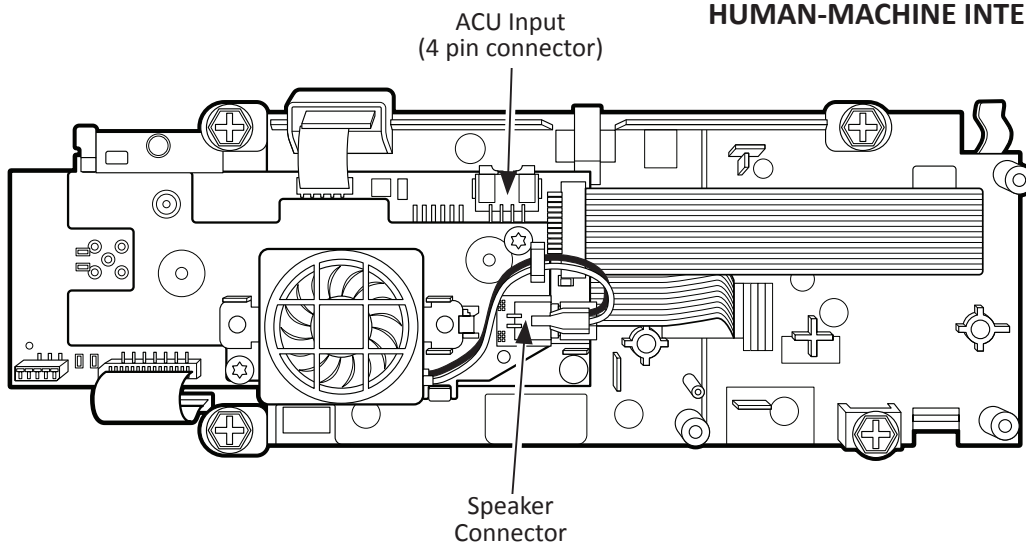

Figure 2 - Connector Locations on HMI

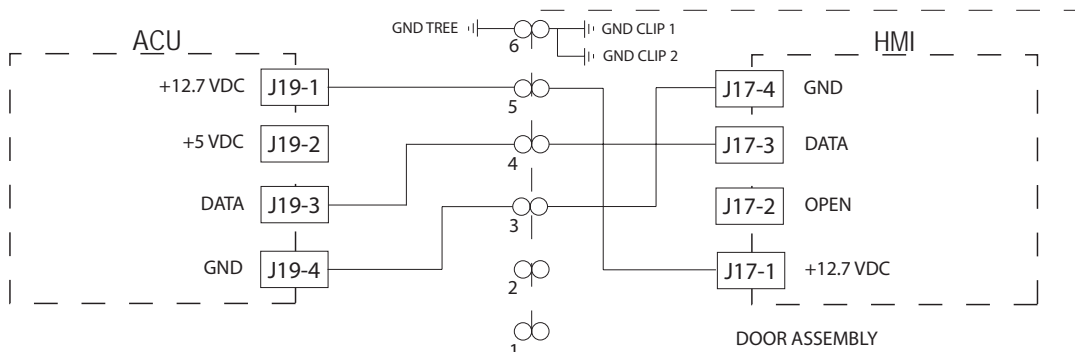



Figure 3 - Human-Machine Interface (HMI) Strip Circuit

For Service Technician Use Only

⚠ WARNING



Electrical Shock Hazard
Disconnect power before servicing.
Replace all parts and panels before operating.
Failure to do so can result in death or electrical shock.

TEST #2B: Human-Machine Interface (HMI) “Console Models”

This test is performed when any of the following situations occurs during the Human-Machine Interface (HMI) Test (see page 2-5):

- **None of the indicators or display turn on**
- **Some buttons do not light indicators**
- **No beep sound is heard**

None of the indicators or display turn on:

1. Unplug washer or disconnect power.
2. Remove the top panel to access the ACU.
3. Visually check that all ACU connectors are inserted all the way into the ACU. See Figure 2, page 3-7.
4. Remove console assembly. Do not pull on the wires between the console and ACU.
5. Visually check that all HMI connectors are inserted all the way into the HMI. See Figures 1 & 2.
6. Visually check that the HMI and housing assembly is properly inserted into the front console.
7. If all visual checks pass, perform TEST #1: ACU Power Check, page 3-6, to verify supply voltage and health of microcontroller.
 - If supply voltages are present and microcontroller is functioning properly, replace the HMI and housing assembly.
 - If supply voltages are not present and Service LED is off or blinking constantly, replace the ACU.
8. Reassemble all parts and panels.
9. Plug in washer or reconnect power.
10. Perform the “Human-Machine Interface (HMI) Test” (see page 2-5) to verify repair.

Some buttons do not light indicators:

1. Unplug washer or disconnect power.
2. Remove the top panel to access the ACU and Human-Machine Interface (HMI).
3. Visually check that the HMI and housing assembly is properly inserted into the front console.
4. If visual check passes, replace the HMI and housing assembly.
5. Reassemble all parts and panels.
6. Plug in washer or reconnect power.
7. Perform the “Human-Machine Interface (HMI) Test” (see page 2-5) to verify repair.

No beep sound is heard:

NOTE: Some washers may have a feature to turn off the button sounds that the user may have activated. Refer to the “Use and Care Guide” for that model to restore beep sounds (if applicable). If no beep sound persists, follow these steps:

1. Unplug washer or disconnect power.
2. Remove the top panel to access the ACU.
3. Visually check that all ACU connectors are inserted all the way into the ACU. See Figure 2, page 3-7.
4. Remove console assembly. Do not pull on the wires between the console and ACU.
5. Visually check that all HMI connectors are inserted all the way into the HMI. See Figures 1 & 2.
6. If all visual checks pass, replace the HMI and housing assembly.
7. Perform the “Human-Machine Interface (HMI) Test” (see page 2-5) to verify repair.

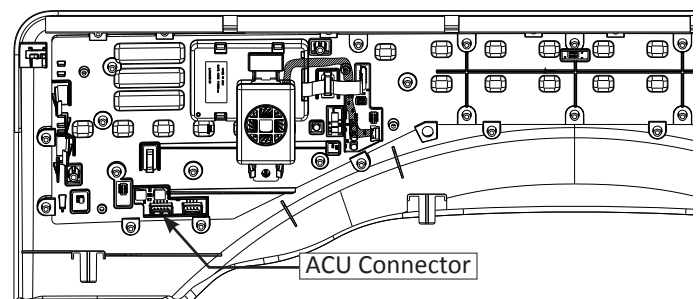

Figure 1 - Whirlpool Console HMI

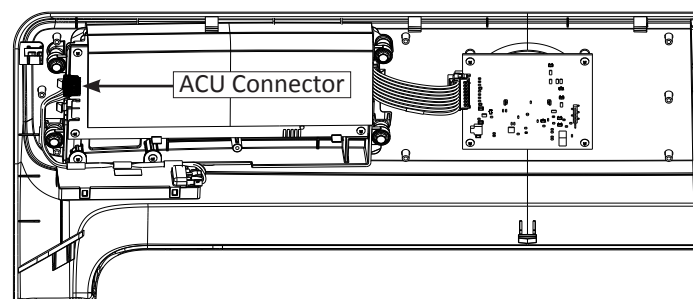



Figure 2 - Maytag Console HMI

For Service Technician Use Only

⚠ WARNING



Electrical Shock Hazard

Disconnect power before servicing.

Replace all parts and panels before operating.

Failure to do so can result in death or electrical shock.

TEST #3: Motor Circuit

NOTE: There are two motor sizes available in the washers. One size for 4.3/4.5 cu.ft. drums, the other for 4.8/5.0 cu.ft. drums. Refer to parts list, by model number when ordering the motor. This test checks the motor, appliance control unit (ACU), and wiring.

1. Check the motor and electrical connections by performing the "Quick Service Cycle" on page 2-7 (console models), or page 2-12 (LCD models). The following steps assume that this step was unsuccessful.
2. Unplug washer or disconnect power.
3. Check to see if basket will turn freely.
 - If basket turns freely, go to step 4.
 - If basket does not turn freely, determine what is causing the mechanical friction or lockup.
4. Remove the top to access the ACU.
5. Perform TEST #1: ACU Power Check, page 3-6, then visually check that connector J6 is inserted all the way into the ACU. Refer to Figure 2 on page 3-7.
 - If visual checks pass, go to step 6.
 - If visual checks fail, reconnect J6 and repeat step 1.

6. Check the motor windings. Disconnect the motor harness from the ACU. With an ohmmeter, verify the resistance values as shown below:

| Motor Harness | Windings |
|----------------|----------|
| J6, Pins 1 & 2 | 6-20 Ω |
| J6, Pins 2 & 3 | 6-20 Ω |
| J6, Pins 1 & 3 | 6-20 Ω |

- If the values are outside the range or open, replace stator assembly; otherwise, reconnect the motor harness and go to step 7.
7. Plug in washer or reconnect power.
 8. **Console Model:** Run the "Quick Service Cycle" on page 2-7. When the test shows "009 & 013" on the display, the motor is powered and the motor should be moving. If it is not, replace the ACU.

LCD in Door Model: Run the "Quick Service Cycle" on page 2-12. When the test shows "009 & 013" on the display, the motor is powered and the motor should be moving. If it is not, replace the ACU.

IMPORTANT: Door must be closed and locked to run motor.
 9. Unplug washer or disconnect power.
 10. Reassemble all parts and panels.
 11. Perform the "Quick Service Cycle" to verify repair.

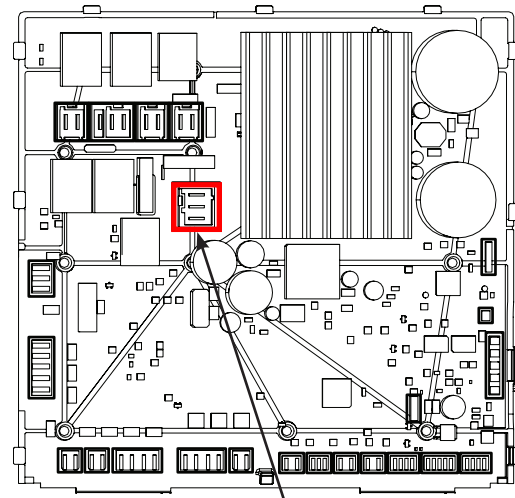

Figure 1 - Location of Motor Harness Connector on ACU

MOTOR

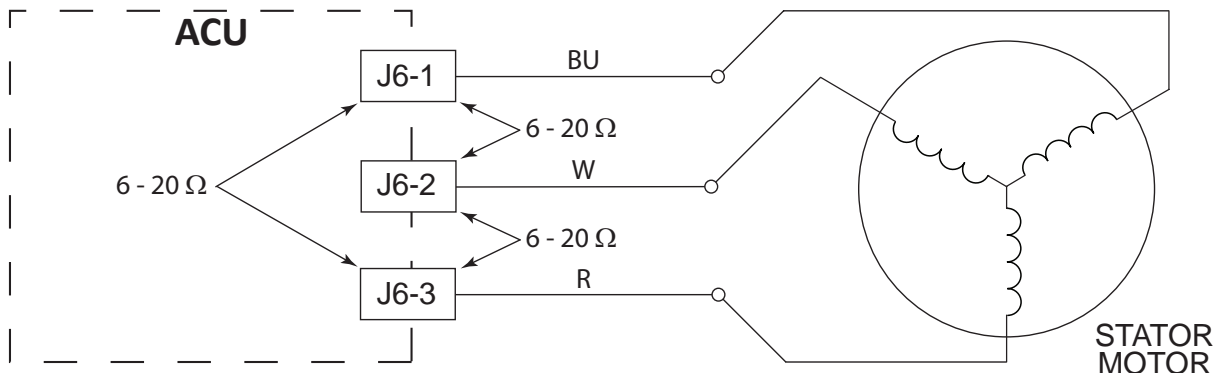



Figure 2 - Direct Drive Motor Strip Circuit

For Service Technician Use Only

⚠ WARNING



Electrical Shock Hazard

Disconnect power before servicing.

Replace all parts and panels before operating.

Failure to do so can result in death or electrical shock.

5. Disconnect the **J7** connector from the ACU. **NOTE:** To measure the door lock switch in the “locked” position, plug in washer or reconnect power. Press the **POWER** button, select any cycle, and then press **START**. Actuation of the door lock solenoid should be heard after a few seconds. At that point, unplug the washer and disconnect **J7** from the ACU and measure resistance across pins (ACU side) according to the following chart.

| Component | Resistance | Contacts Measured | |
|---------------|--|-------------------|------|
| Door Switch | Door Open = Open Circuit Door Closed = 60-90 ohms | J7-2 | J7-3 |
| Lock Switch | Locked = 0 ohms Unlocked = Open Circuit | J7-1 | J7-2 |
| Lock Solenoid | 60-90 ohms with door closed | J7-2 | J7-3 |

TEST #4: Door Lock System

Check the relays and electrical connections to the door lock by performing the “Quick Service Cycle” on page 2-7 (console models), or page 2-12 (LCD models). The following steps assume that this step was unsuccessful.

1. Check door lock mechanism for obstruction or binding. Repair as necessary.
2. Unplug washer or disconnect power.
3. Remove top panel to access machine electronics.
4. Visually check that the **J7** (door lock assembly) connector is inserted all the way into the ACU. Refer to ACU diagram on page 3-7.
 - If visual check passes, go to step 5.
 - If the connector is not inserted properly, reconnect and retest door lock.
5. Disconnect the **J7** connector from the ACU. **NOTE:** To measure the door lock switch in the “locked” position, plug in washer or reconnect power. Press the **POWER** button, select any cycle, and then press **START**. Actuation of the door lock solenoid should be heard after a few seconds. At that point, unplug the washer and disconnect **J7** from the ACU and measure resistance across pins (ACU side) according to the following chart.
 - If resistance values are good, go to step 6.
 - If any of the measurements are out of range, check the harness of the suspected component between the ACU and door lock mechanism for continuity.
 - If the harness and connections are good, replace the door lock mechanism. **IMPORTANT:** To minimize risk of damage to door lock/switch wires, remove the door lock mechanism screws before removing the front panel.
6. If the preceding steps did not correct the lock problem, replace the ACU and retest door lock mechanism.
 - a. Unplug washer or disconnect power.
 - b. Replace the ACU.
 - c. Reassemble all parts and panels.
 - d. Perform the “Quick Service Cycle” on page 2-7 (console models), or page 2-12 (LCD models) to verify repairs.

DOOR LOCK SYSTEM

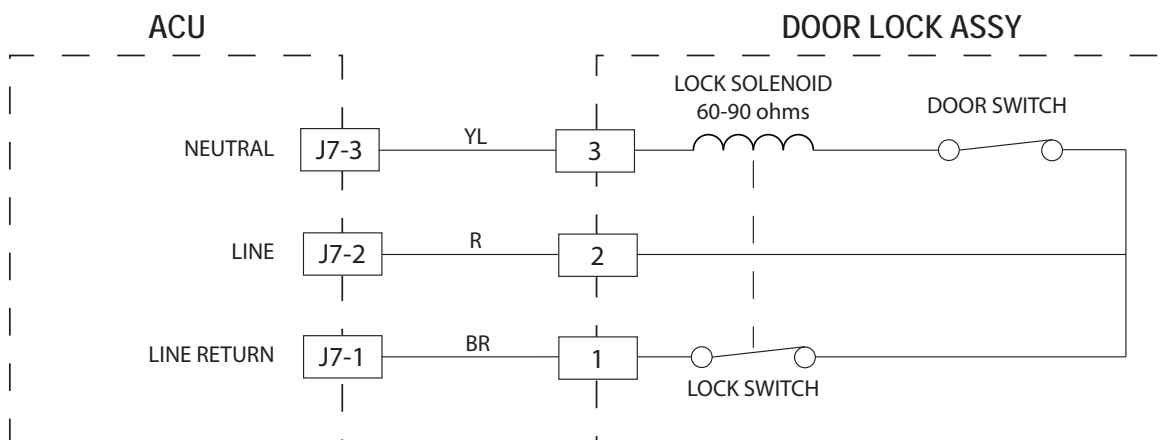



Figure 1 - Door Lock Strip Circuit

For Service Technician Use Only

⚠ DANGER



Electrical Shock Hazard

Only authorized technicians should perform diagnostic voltage measurements.

After performing voltage measurements, disconnect power before servicing.

Failure to follow these instructions can result in death or electrical shock.

This test is performed if the drum LED does not light.

1. Unplug washer or disconnect power.
2. Remove the top panel to access ACU.
3. Verify the drum light connector **J16** is securely connected to the ACU. Refer to Figure 1 below or on page 3-7.
4. Check harness and connections between the drum light and the ACU.
 - If the connections are OK, go to step 5.
 - If not, repair or replace as needed.
5. Unplug the drum light from the harness that goes into the ACU.
6. Plug in washer or reconnect power.
7. With a voltmeter set to VDC, measure the voltage across J16, pins 1 and 3. If the drum LED driver is working properly, you should measure 2.9-3.5 VDC.
 - If the voltage is present, replace the drum LED.
 - If the voltage is not present, replace the ACU.
8. Unplug washer or disconnect power.
9. Reassemble all parts and panels.

TEST #5: Drum Light (on some models)

Theory of Operation

The drum light is activated by the ACU. When the ACU detects the door-switch transition from closed to open, the ACU will automatically turn on the light within 1 second. When the door-switch transitions from open to closed, the ACU will automatically turn off the light within 1 second.

The software will turn off the drum light if the washer status changes from "Programming Mode" to "Standby Mode."

The software will turn off the drum light after being on for 5 minutes when the door is opened during "Pause Mode" whether the door is closed or not.

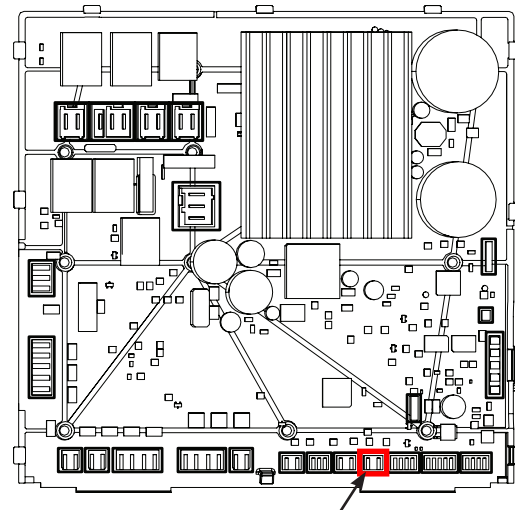

Figure 1 - Location of Drum Light Connector on ACU

DRUM LIGHT

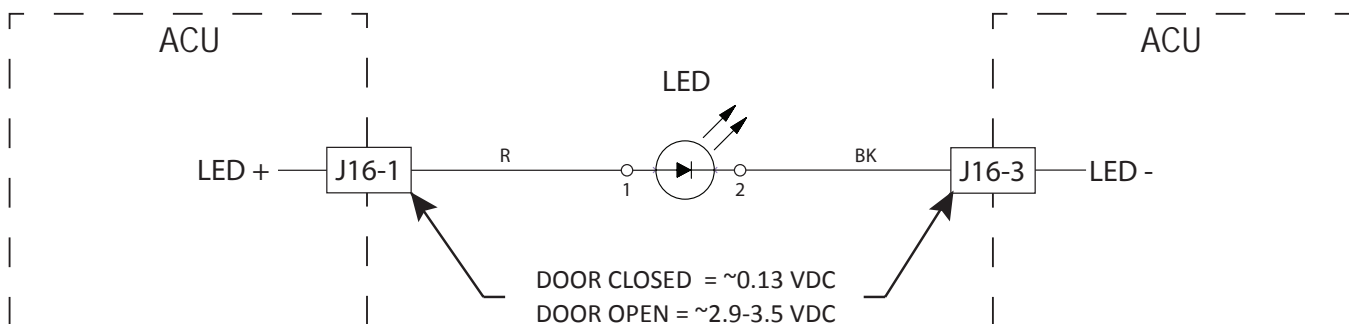



Figure 2 - Drum Light Strip Circuit

For Service Technician Use Only

⚠ DANGER



Electrical Shock Hazard

Only authorized technicians should perform diagnostic voltage measurements.

After performing voltage measurements, disconnect power before servicing.

Failure to follow these instructions can result in death or electrical shock.

1. Check the relays and electrical connections to the valves by performing the “Quick Service Cycle” on page 2-7 (console models), or page 2-12 (LCD models). The following steps assume that this step was unsuccessful.
2. For the valve(s) in question, check the individual solenoid coils:
 - a. Unplug washer or disconnect power.
 - b. Remove top panel to access machine electronics.
 - c. Remove connector **J8** from the ACU. Refer to ACU diagram on page 3-7.
 - d. Check harness connections to the solenoid valves. Verify continuity in harness between ACU and solenoid valves.
3. Check valve coil resistance at the valves, or across the following connector pinouts:

| Valve | Pinout |
|-------------------|----------------|
| Cold 1 Fill Valve | J8, pins 1 & 2 |
| Cold 2 Fill Valve | J8, pins 1 & 3 |
| Hot 1 Fill Valve | J8, pins 1 & 5 |

Resistance should be 1.1 - 1.35k Ω .

- If resistance readings are outside the range or open, replace the valve assembly.
 - If resistance readings are within range, reconnect **J8** to ACU. Go to step 4.
4. Plug in washer or reconnect power.
 5. With a voltmeter set to **AC**, attach the leads across the pins of the suspect valve (see chart in step 3). Run the “Load Test” (console model) on page 2-6. *Step 3=cold 1 valve, Step 4=cold 2 valve, Step 5=hot valve.* Or, the “Component Activation Test” (LCD model) on page 2-10.
 - If line voltage is present and valve still does not activate, replace valve assembly.
 - If line voltage is not present, replace the ACU.
 6. Unplug washer or disconnect power.
 7. Reassemble all parts and panels.
 8. Perform the “Quick Service Cycle” on page 2-7 (console models), or page 2-12 (LCD models) to verify repairs.

TEST #6: Water Inlet Valves

This test checks the electrical connections to the valves and the valves themselves. Water valve names and locations are as follows:

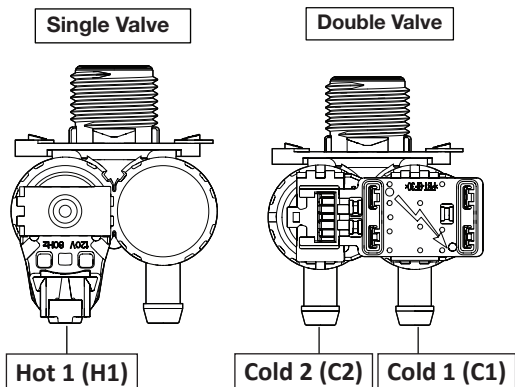

Figure 1 - Single & Double Water Inlet Valves

INLET WATER VALVES

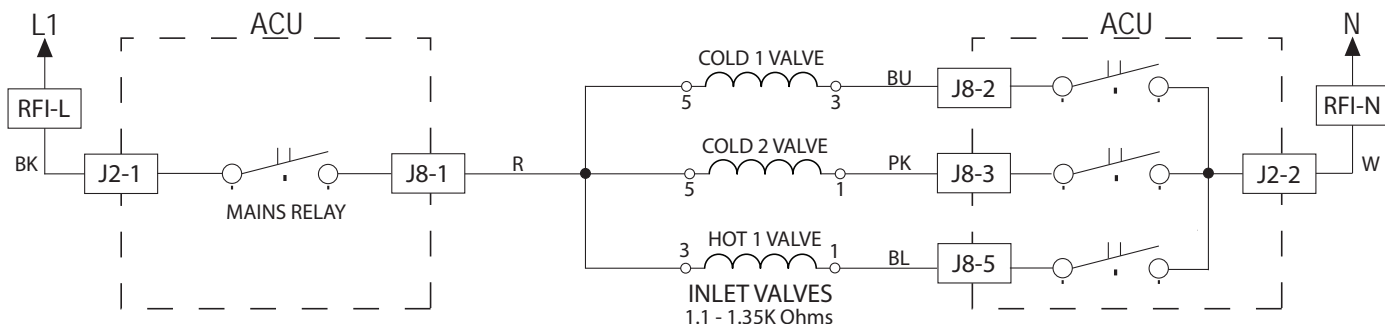



Figure 2 - Inlet Water Valves Strip Circuit

For Service Technician Use Only

⚠ DANGER



Electrical Shock Hazard

Only authorized technicians should perform diagnostic voltage measurements.

After performing voltage measurements, disconnect power before servicing.

Failure to follow these instructions can result in death or electrical shock.

TEST #7: Water Level Sensor

This test checks the water level sensor, ACU, and wiring.
NOTE: Usually, if the water level sensor malfunctions, the washer will generate a long fill or long drain error.

1. Check the functionality of the water level sensor by running a small load cycle. The valves should turn off automatically after sensing the correct water level in the tub. The following steps assume that this step was unsuccessful.
2. Press **START/PAUSE** to pause the cycle and then press **POWER**. The cycle will cancel and drain the water from the tub.
3. Unplug washer or disconnect power.
4. Remove top and rear panels to access tub, air trap, and pressure hose connections. Water level sensor is located at top center of right cabinet panel.
5. Check connections from tub to air trap, air trap to pressure hose, and pressure hose to water level sensor.
6. Check to ensure hose is routed correctly in the lower cabinet and not pinched or crimped.
7. Verify there is no water, suds, or debris in the hose or air trap. Disconnect hose from water level sensor and blow into hose to clear water, suds, or debris.

8. Check hose for leaks. Replace if needed.
9. Visually check that connector **J14** is inserted all the way into the ACU (refer to ACU diagram on page 3-7). Also check that the water level sensor harness is securely connected to the sensor.
10. Check the harness between the ACU and water level sensor for continuity.
 - If there is continuity, go to step 11.
 - If there is no continuity, repair or replace as necessary.
11. Plug in washer or reconnect power.
12. With a voltmeter set to DC, connect black probe to ACU connector **J14**, pin 2 (GND) and red probe to **J14**, pin 3 (+5 V [Vcc]).
 - If +5 VDC is present, replace the water level sensor. (Before replacing the sensor, make sure that there is NO water remaining in the tub or there will not be an accurate water level measurement and an error code may appear. Drain the tub by running a drain & spin cycle with the sensor plugged into J14 but with the hose removed).
 - If +5 VDC is not present, perform TEST #1: ACU Power Check on page 3-6.
13. If the preceding steps did not correct the problem, replace the ACU.
 - a. Unplug washer or disconnect power.
 - b. Replace the ACU.
 - c. Reassemble all parts and panels.
 - d. Perform the “Quick Service Cycle” on page 2-7 (console models), or page 2-12 (LCD models) to verify repairs.

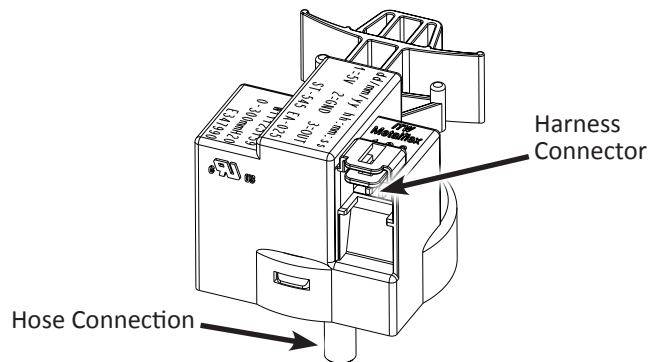

Figure 1 - Water Level Switch

WATER LEVEL SWITCH

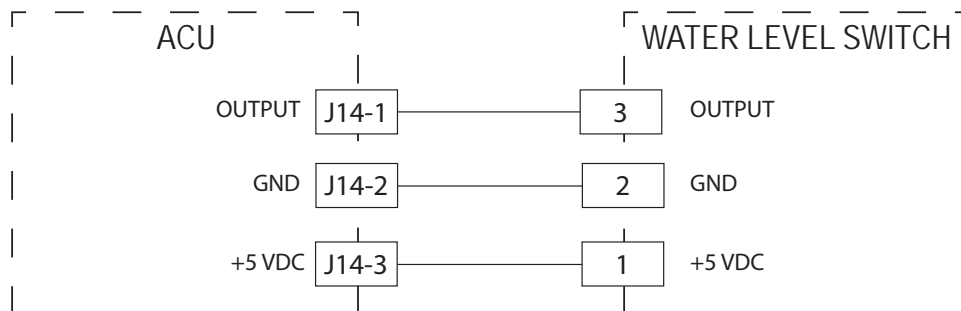



Figure 2 - Water Level Switch

For Service Technician Use Only

⚠ WARNING



Electrical Shock Hazard

Disconnect power before servicing.

Replace all parts and panels before operating.

Failure to do so can result in death or electrical shock.

TEST #8: Drain/Recirculation Pump

Perform the following checks if washer does not drain.

1. Check for obstructions in the usual areas. Clean and then perform step 2.
2. Check the Drain Pump/Recirculation Pump and electrical connections by performing the "Quick Service Cycle" on page 2-7 (console models), or page 2-12 (LCD models). The following steps assume that this step was unsuccessful.
3. Unplug washer or disconnect power.
4. Remove top panel to access machine electronics.
5. Visually check that the **J11** connector is inserted all the way into the ACU. Refer to ACU diagram on page 3-7.
 - If visual check passes, go to step 6.
 - If connector is not inserted properly, reconnect **J11** and repeat step 2.
6. Remove connector **J11** from the ACU. With an ohmmeter, measure the resistance across connector pins.

| Motor | ACU Pins | Resistance |
|--------------------|----------------|---------------|
| Drain Pump | J11-1 to J11-2 | 18.5 - 21.5 Ω |
| Recirculation Pump | J11-3 to J11-4 | 36 - 46 Ω |

7. Resistance should be within range at room temperature.
 - If the reading is infinite (open), go to step 8.
 - If the reading is correct, go to step 12.
8. Open bulk drawer and remove pump filter cap. Remove bulk drawer, front panel and backer to access Drain Recirculation Pump. Verify that pump, pump filter, drain hose, recirculation hose/nozzle, and pressure switch hose are free from obstructions.
9. Visually check the electrical connections at the Drain Pump and Recirculation Pumps.
 - If visual check passes, go to step 10.
 - If connections are loose, reconnect the electrical connections and repeat step 2.
10. With an ohmmeter, check harness for continuity between the Drain Pump/Recirculation Pump and ACU.
 - If there is continuity, go to step 11.
 - If there is no continuity, replace the lower machine harness and repeat step 2.
11. With an ohmmeter, measure the resistance across the two pump terminals using the chart in step 6.
 - If the reading is infinite (open), replace the drain pump assembly.
 - If the reading is correct, go to step 12.
12. If the preceding steps did not correct the drain problem, replace the ACU.
 - a. Unplug washer or disconnect power.
 - b. Replace the ACU.
 - c. Reassemble all parts and panels.
 - d. Perform the "Quick Service Cycle" on page 2-7 (console models), or page 2-12 (LCD models) to verify repairs.

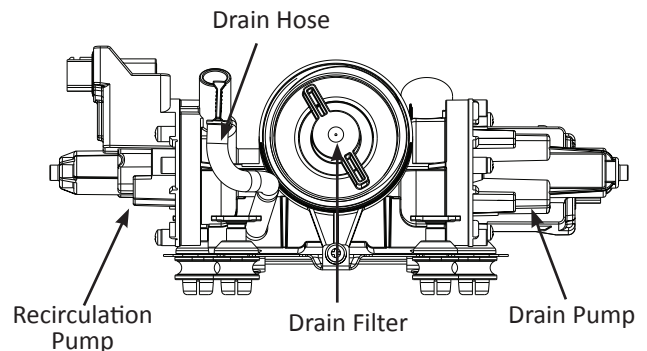

Figure 1 - Drain/Recirculation Pump

DRAIN/RECIRCULATION PUMP

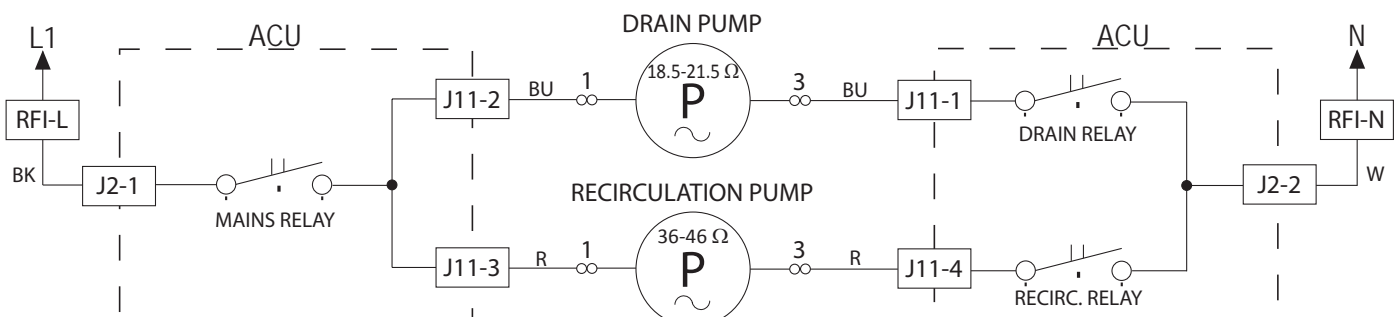



Figure 2 - Drain/Recirculation Pump Strip Circuit

For Service Technician Use Only

⚠ WARNING



Electrical Shock Hazard
Disconnect power before servicing.
Replace all parts and panels before operating.
Failure to do so can result in death or electrical shock.

8. If the preceding steps did not correct the heating element problem, replace the ACU.
 - a. Unplug washer or disconnect power.
 - b. Replace the ACU.
 - c. Reassemble all parts and panels.
 - d. Perform the "Quick Service Cycle" on page 2-7 (console models), or page 2-12 (LCD models) to verify repairs.

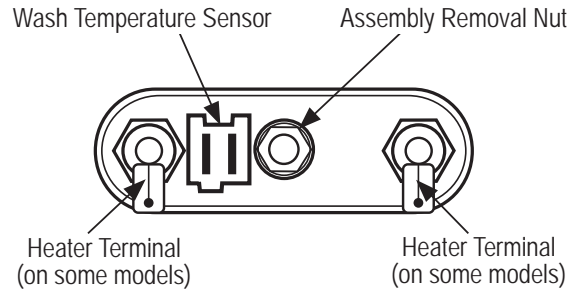

Figure 1 - Heating/Temperature Sensor Assembly

TEST #9: Wash Heating Element (on some models)

This test checks the heating element, wiring, and ACU.

1. Unplug washer or disconnect power.
2. Remove top panel to access machine electronics.
3. Disconnect connector **J3** from the ACU. Refer to ACU diagram on page 3-7.
4. Using an ohmmeter, measure the resistance across pins 1 and 2 of connector **J3**.
 - If the resistance is 7-30 Ω , the heating element and wiring are good; go to step 8.
 - If the resistance is open, go to step 5.
5. Remove back panel to access the heating element.
6. Disconnect the wire connectors from the heating element. See Figure 1.
7. Using an ohmmeter, measure the resistance across the two heating element terminals.
 - If the resistance is 7-30 Ω , the heating element is good; replace the lower main harness.
 - If the resistance is open, replace the heating element.

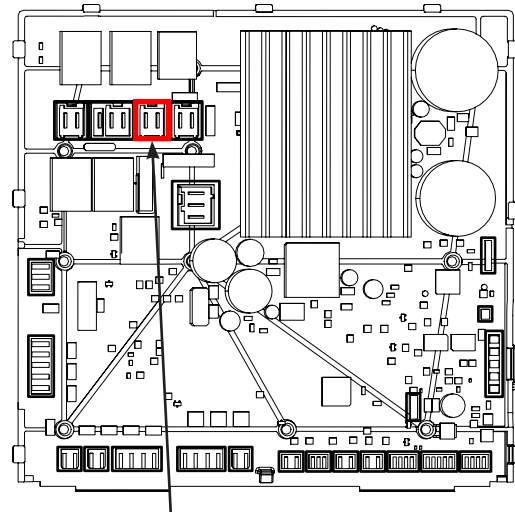

Figure 2 - Location of Wash Heater Connector on ACU

WASH HEATING ELEMENT

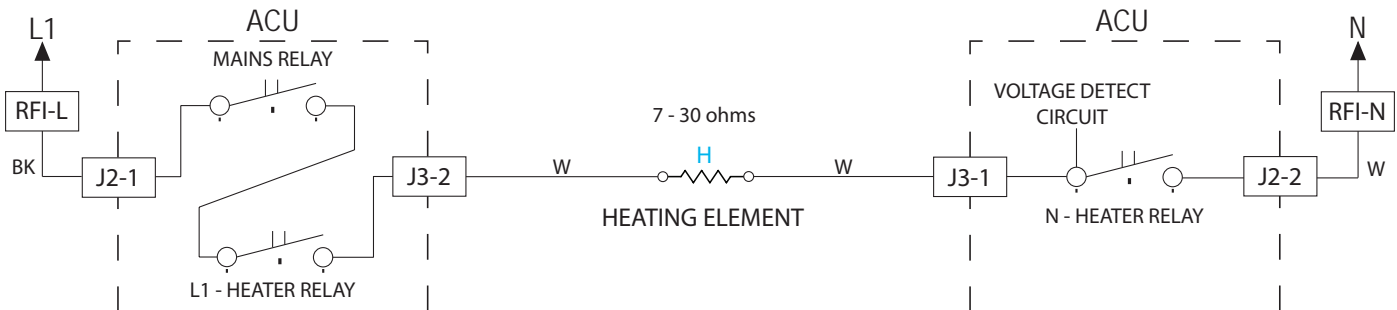



Figure 3 - Wash Heating Element Strip Circuit

For Service Technician Use Only

⚠ WARNING



Electrical Shock Hazard
Disconnect power before servicing.
Replace all parts and panels before operating.
Failure to do so can result in death or electrical shock.

TEST #10: Wash Temperature Sensor

This test checks the temperature sensor, wiring, and ACU.

1. Unplug washer or disconnect power.
2. Remove top panel to access machine electronics.
3. Disconnect connector **J15** from the ACU. Refer to ACU diagram on page 3-7.
4. Using an ohmmeter, measure the resistance across pins 1 and 3 of wash temperature sensor connector **J15**. Refer to the following chart.

| THERMISTOR SENSOR RESISTANCE | | |
|------------------------------|-----|--------------------|
| Approx. Temperature | | Approx. Resistance |
| F° | C° | (KΩ) |
| -4 | -20 | 197.3 |
| 14 | -10 | 111.6 |
| 32 | 0 | 65.5 |
| 59 | 15 | 31.5 |
| 77 | 25 | 20.0 |
| 86 | 30 | 16.1 |
| 104 | 40 | 10.6 |
| 122 | 50 | 7.1 |

| THERMISTOR SENSOR RESISTANCE | | |
|------------------------------|-----|--------------------|
| Approx. Temperature | | Approx. Resistance |
| 140 | 60 | 4.9 |
| 158 | 70 | 3.4 |
| 176 | 80 | 2.4 |
| 194 | 90 | 1.8 |
| 212 | 100 | 1.3 |
| 248 | 120 | 0.7 |
| 302 | 150 | 0.3 |

- If the resistance is within the specified range, go to step 8.
 - If the resistance is infinite or close to zero, go to step 5.
5. Remove the back panel to access the temperature sensor.
 6. Disconnect the wash temperature sensor connector from the heating element bracket. See Figure 1.
 7. Using an ohmmeter, measure the resistance across pins of the temperature sensor (on the heating element bracket).
 - If the resistance is within the specified range, the sensor is good; replace the lower main harness.
 - If the resistance is open, replace the wash temperature sensor.
 8. If the preceding steps did not correct the wash temperature sensor problem, replace the ACU.
 - a. Unplug washer or disconnect power.
 - b. Replace the ACU.
 - c. Reassemble all parts and panels.
 - d. Perform the "Quick Service Cycle" on page 2-7 (console models), or page 2-12 (LCD models) to verify repairs.

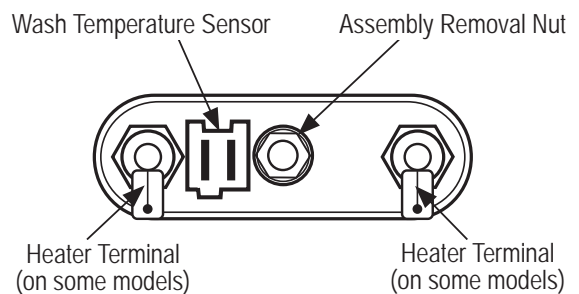

Figure 1 - Wash Temperature Sensor

WASH TEMPERATURE SENSOR

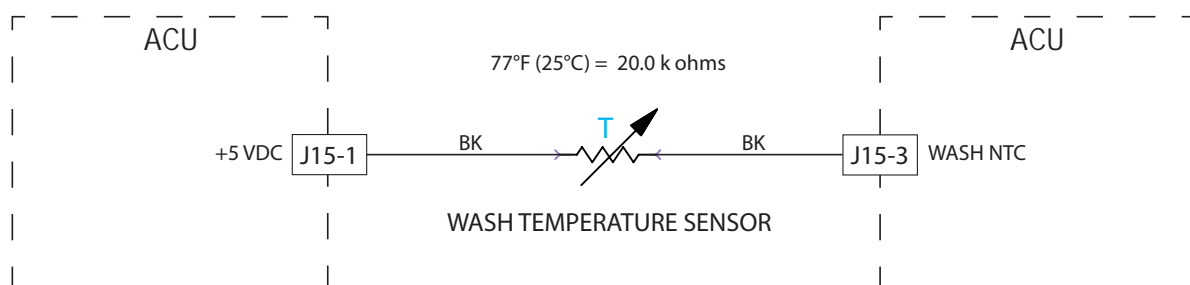



Figure 2 - Wash Temperature Sensor Strip Circuit

For Service Technician Use Only

| |
|---|
| ⚠ WARNING |
|  |
| Electrical Shock Hazard Disconnect power before servicing. Replace all parts and panels before operating. Failure to do so can result in death or electrical shock. |

TEST #11A: Single Dose Dispenser

Perform the following checks if the washer will not dispense detergent, bleach, or fabric softener.

1. Check water supply to washer. Check water hose connections to and inside the washer.
2. Verify that dispenser drawer is not clogged with detergent.
3. Unplug washer or disconnect power.
4. Remove the top panel to access the machine electronics.
5. Verify that all valves are working through TEST #6 on page 3-13. See TEST #6 for valve descriptions. The water is dispensed as follows:
 - **Detergent Dispenser:** Through valves **Cold 1** and **Hot 1** (hot and cold water)
 - **Bleach:** Through valve **Cold 2** (only cold water)
 - **Fabric Softener:** Through valves **Cold 1** and **Cold 2**. Both valves need to be functioning for water to be dispensed through this chamber.
6. If the quick diagnostic test shows that the valves are functioning and a problem persists, replace the dispensing system.

NOTE: There may be some water left in the bleach dispenser during any cold water dispensing in the system due to splash.

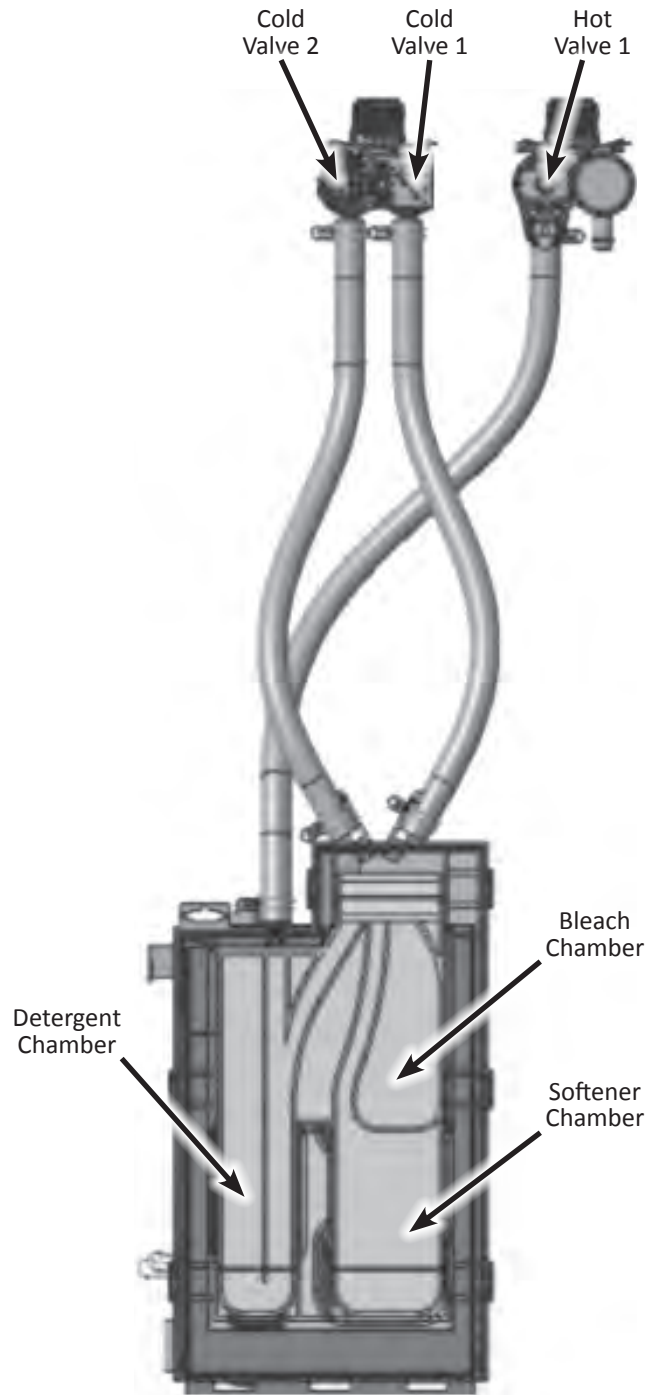



Figure 1 - Dispenser System, Valves & Chambers

For Service Technician Use Only

⚠ **WARNING**



Electrical Shock Hazard

Disconnect power before servicing.

Replace all parts and panels before operating.

Failure to do so can result in death or electrical shock.

- If there is continuity, go to step 7.
 - If there is no continuity, replace the upper machine harness and repeat step 2.
7. With an ohmmeter, measure the resistance across pins 1 & 3 of the pump connector. Resistance should be between **1.6 to 1.96 kΩ**.
 - If the resistance is infinite (open), replace the dosing pump.
 - If the resistance is in the correct range, go to step 8.
 8. If the preceding steps did not correct the problem, replace the ACU.
 - a. Unplug washer or disconnect power.
 - b. Replace the ACU.
 - c. Reassemble all parts and panels.
 - d. Perform the “Quick Service Cycle” on page 2-7 (console models), or page 2-12 (LCD models) to verify repairs.

TEST #11B: Optimal Dispense – Dosing Pump (on some models)

Perform the following checks if the dosing pump does not dispense detergent to the tub.

1. Verify that the reservoirs are not clogged with detergent.
 - If the reservoirs are clogged, remove from unit and fill/rinse them thoroughly with the aid of hot water to clean build up from reservoirs.
2. Check the detergent dosing pump and electrical connections by performing the “Quick Service Cycle” on page 2-7 (console models). The following steps assume that this step was unsuccessful. The following steps assume that this step was unsuccessful.
3. Unplug washer or disconnect power.
4. Remove top panel to access machine electronics.
5. Visually check that connector **J10** is inserted all the way into the ACU (refer to ACU diagram on page 3-7). Also check that the harness is securely connected to the detergent dosing pump.
 - If visual check passes, go to step 6.
 - If connector is not inserted properly, reconnect **J10** and repeat step 2.
6. With an ohmmeter, check harness for continuity between the dosing pump and the ACU.

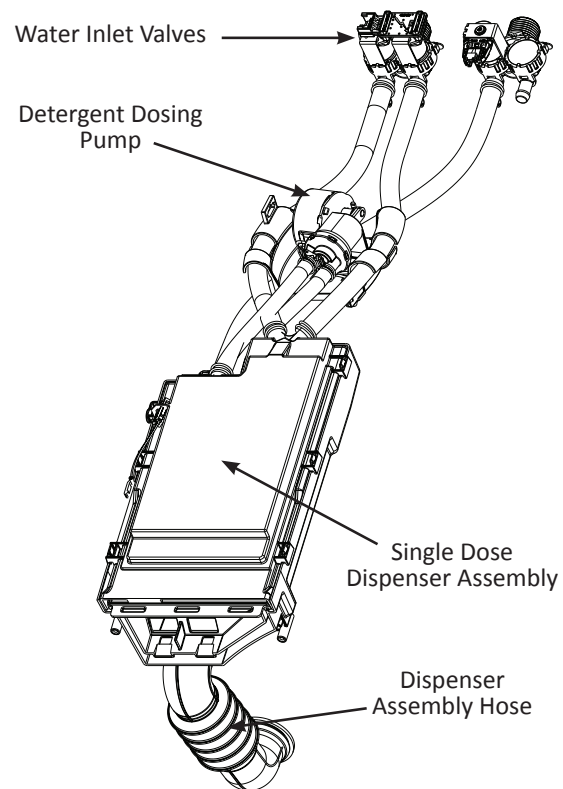

Figure 1 - Optimal Dispenser - Dosing Pump Location

DETERGENT DOSING PUMP

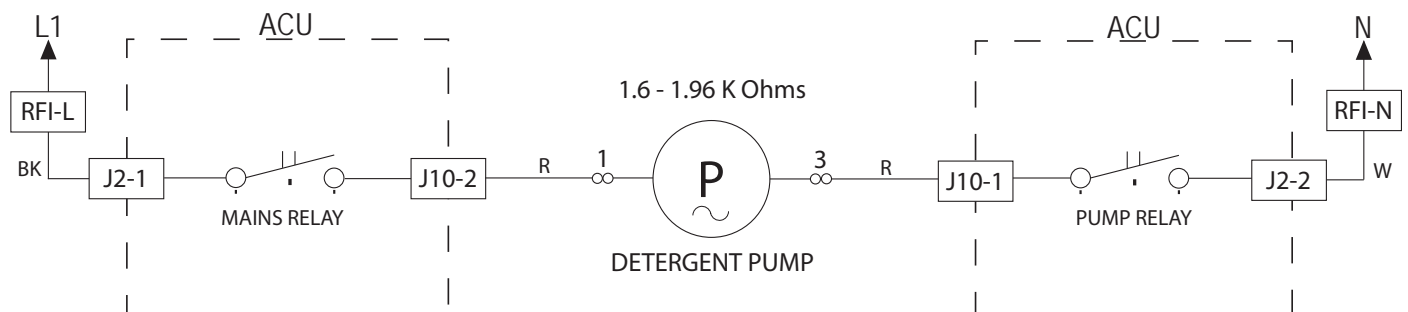



Figure 2 - Detergent Dosing Pump Strip Circuit

For Service Technician Use Only

⚠ WARNING



Electrical Shock Hazard

Disconnect power before servicing.

Replace all parts and panels before operating.

Failure to do so can result in death or electrical shock.

TEST #12A: Drawer Bulk Dispenser (on some models)

Check the detergent dosing pump and electrical connections by performing the “Quick Service Cycle” on page 2-7 (console models), or page 2-12 (LCD models).

Perform the following checks if the washer will not dispense detergent or fabric softener.

DISPENSER TANKS, FITTINGS, AND HOSES

1. Verify that the dispenser tank(s) are not clogged with detergent or fabric softener.
 - If the tank(s) are clogged, remove from washer and fill/rinse them thoroughly with the aid of hot water to clean build-up from tank(s).
 - Inspect docking interface(s) on the tank(s) after rinsing to ensure residue is removed from the area. If residue remains, remove and rinse with hot water.
2. Check the Drain/Recirculation Pump filter for foreign objects or lint.
 - Open the bulk dispenser drawer. Remove the drawer by releasing the retention tab on each side (see Figure 1 on page 1-12).
 - Remove the drain hose from the clip, unplug hose and allow it to drain. Remove drain filter and clean.

3. Check that the dispensing hose connections to the Drain/Recirculation Pump and to the dispenser tank(s) are not kinked, unattached, or clogged.
 - Remove the top panel, console, and bulk dispense drawer. Remove the bellow’s wire retainer and front panel to allow access to the metering support bracket.
4. Check/clean recirculation nozzle for lint accumulation.
 - Verify that the nozzle located on the bellows allow recirculation water/additives to flow freely.

DOSING PUMP TEST

NOTE: Tank(s) must be placed into dispenser drawer for pump to operate.

1. Unplug washer or disconnect power.
 - Remove the top panel, console, and bulk dispense drawer. Remove the bellow’s wire retainer and front panel to allow access to the metering support bracket.
2. Visually check that connector **J10** is inserted all the way into the ACU (refer to ACU diagram on page 3-7). Also check that the harness is securely connected to the detergent dosing pump connector(s) located on top of the metering support bracket.
 - If visual check passes, go to step 3.
 - If connector(s) are not inserted properly, reconnect **J10** or connector(s) on top of backer and retest.
3. With an ohmmeter, check harness for continuity between the dosing pump(s) and the ACU.
 - If there is continuity, go to step 4.
 - If there is no continuity, replace the lower harness and retest.
4. Disconnect the suspected pump connector. With an ohmmeter, measure the resistance across pins 1 & 3 of the pump. Resistance should be between **1.6 to 1.96 kΩ**.
 - If the resistance is infinite (open), replace the dosing pump.
 - If the resistance is in the correct range, go to step 5.
5. If the preceding steps did not correct the problem, replace the ACU.
 - a. Unplug washer or disconnect power.
 - b. Replace the ACU.
 - c. Reassemble all parts and panels.
 - d. Perform the “Quick Service Cycle” on page 2-7 (console models), or page 2-12 (LCD models) to verify repairs.

DETERGENT DOSING PUMP

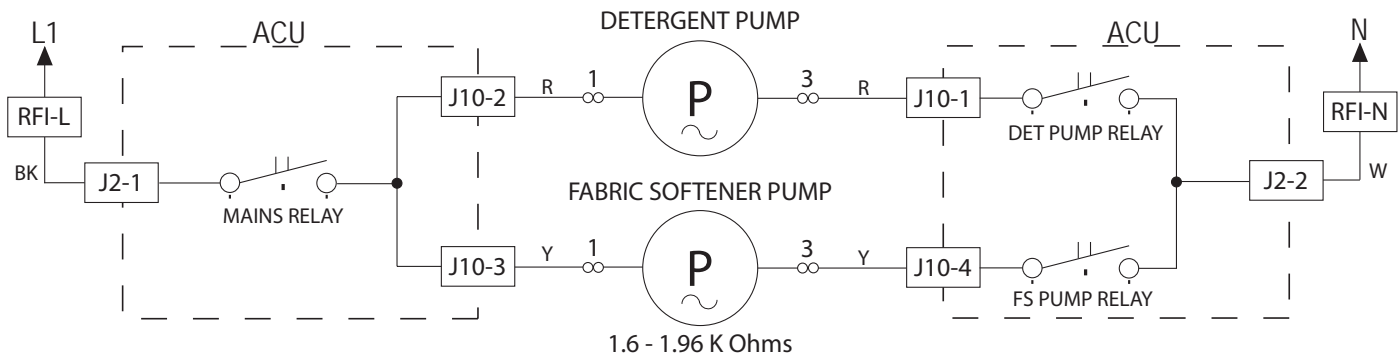



Figure 1 - Detergent Dosing Pump Strip Circuit

For Service Technician Use Only

⚠ WARNING



Electrical Shock Hazard

Disconnect power before servicing.

Replace all parts and panels before operating.

Failure to do so can result in death or electrical shock.

TEST #12B: Drawer Bulk Dispenser Level Sensing (on some models)

NOTE: This procedure applies to both single and dual reservoir systems.

Perform the following checks if the washer cannot detect the level of the detergent or softener in the reservoir.

1. Save customer's detergent or softener in spare container. When reservoir is empty, you should 'hear' the float moving up and down when the reservoir is rotated. If stuck, thoroughly rinse the reservoir with warm water. Fill reservoirs with water to test floats. Reinstall bulk dispenser reservoir in dispenser assembly and check for proper operation.
 - If float is damaged, replace the entire bulk dispenser reservoir. Dispenser reservoirs are not serviceable.
 - If float is working, but detergent/softener level is not detected, go to step 2.
2. Unplug washer or disconnect power.
3. Remove top panel to access machine electronics.
4. Visually check that the **J17** connector is inserted all the way into the ACU.
 - If visual check passes, go to step 5.
 - If connector is not inserted properly, reconnect **J17** and retest.

5. With an ohmmeter, check harness for continuity between the **J17** of the ACU and the level sensor connectors.
 - If there is continuity, go to step 6.
 - If there is no continuity, replace the lower harness and retest.
6. To test either the detergent or fabric softener level sensor, disconnect the appropriate level sensor connector on top of the metering support bracket. Using an ohmmeter, connect leads across pins **1** and **2** of the connector. With the reservoir removed, the sensor should read open.
7. While watching the ohmmeter, place a magnet above the appropriate sensor cavity (see Figure 1). The magnet should close the sensor (less than 3 ohms).
 - If the resistance still reads open, replace the level sensor, otherwise continue to step 8.
8. If the preceding steps did not correct the problem, replace the ACU.
 - a. Unplug washer or disconnect power.
 - b. Replace the ACU.
 - c. Reassemble all parts and panels.

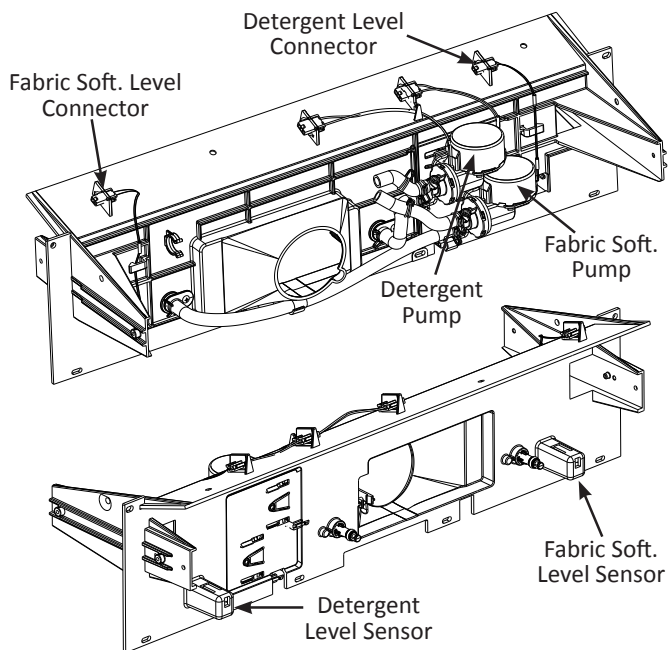

Figure 1 - Drawer Bulk Dispenser Components

BULK DISPENSE LEVEL SENSING

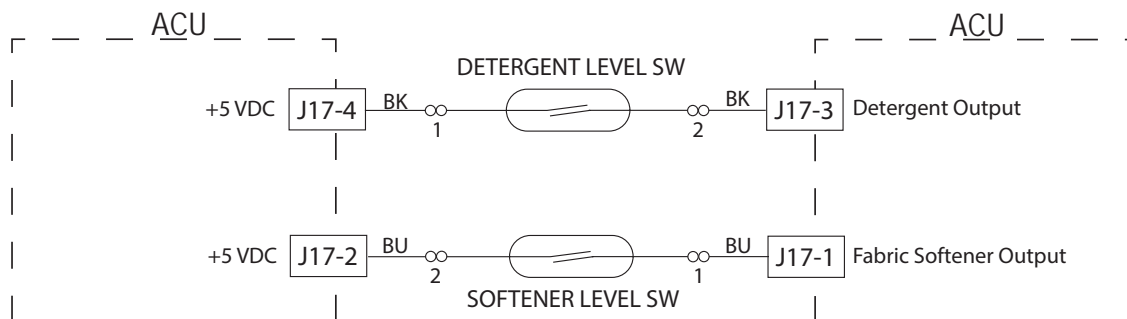



Figure 2 - Bulk Dispense Level Sensing Strip Circuit

For Service Technician Use Only

⚠ WARNING



Electrical Shock Hazard
Disconnect power before servicing.
Replace all parts and panels before operating.
Failure to do so can result in death or electrical shock.

- If there is continuity, go to step 7.
 - If there is no continuity, replace the upper machine harness and repeat step 2.
7. With an ohmmeter, measure the resistance across the two fan terminals. Resistance should be 1.78 to 2.3 K Ω .
- If the resistance is far out of range or open, replace the vent fan assembly.
 - If the resistance is in the correct range, go to step 8.
8. If the preceding steps did not correct the problem, replace the ACU.
- a. Unplug washer or disconnect power.
 - b. Replace the ACU.
 - c. Reassemble all parts and panels.
 - d. Perform the "Quick Service Cycle" on page 2-7 (console models), or page 2-12 (LCD models) to verify repairs.

TEST #13: Vent Fan Motor (on some models)

This test is performed if the vent fan does not activate.

1. Check rear vent for obstruction that could prevent the fan from spinning.
2. Check the vent fan and electrical connections by performing the "Component Activation Test" on page 2-10 (LCD models only). The following steps assume that this step was unsuccessful.
3. Unplug washer or disconnect power.
4. Remove the top panel to access the machine electronics.
5. Visually check that connector **J12** is inserted all the way into the ACU (refer to ACU diagram on page 3-7). Also check that the vent fan harness is securely connected to the fan.
 - If visual check passes, go to step 6.
 - If connector is not inserted properly, reconnect **J12** and repeat step 2.
6. With an ohmmeter, check harness for continuity between the vent fan and the ACU.

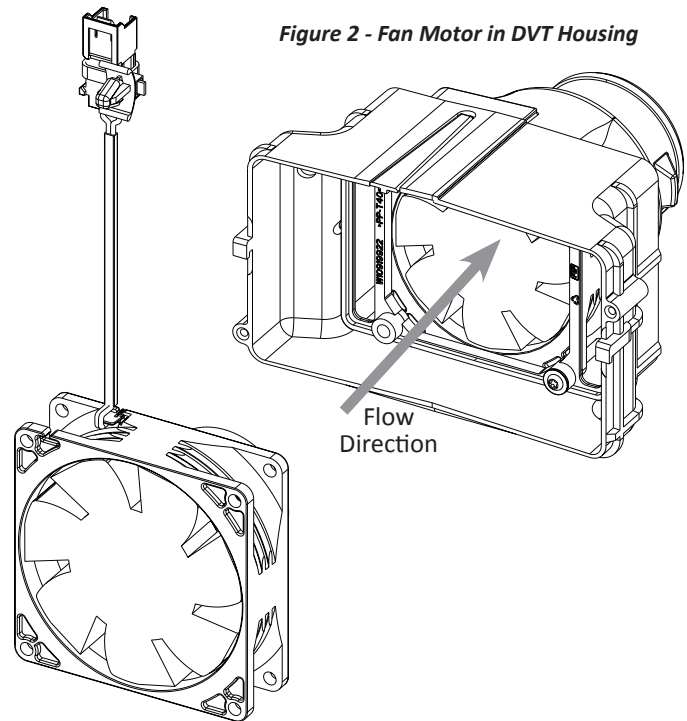

Figure 1 - Fan Motor

VENT FAN MOTOR

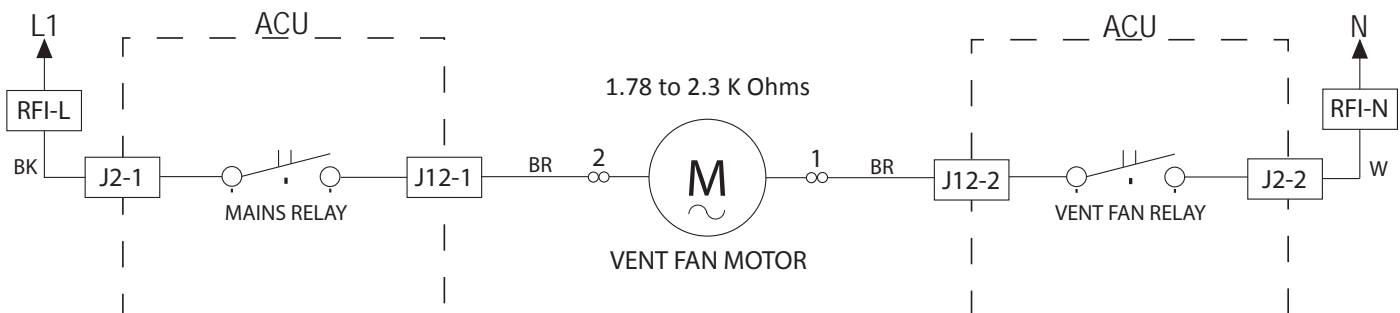



Figure 3 - Vent Fan Motor Strip Circuit

For Service Technician Use Only

⚠ **WARNING**



Electrical Shock Hazard
Disconnect power before servicing.
Replace all parts and panels before operating.
Failure to do so can result in death or electrical shock.

6. With an ohmmeter, measure the resistance across the two solenoid terminals. Resistance should be less than 10 MΩ.
 - If the resistance is infinite (open), replace the solenoid.
 - If the resistance is in the correct range, go to step 8.
7. If the preceding steps did not correct the problem, replace the ACU.
 - a. Unplug washer or disconnect power.
 - b. Replace the ACU.
 - c. Reassemble all parts and panels.

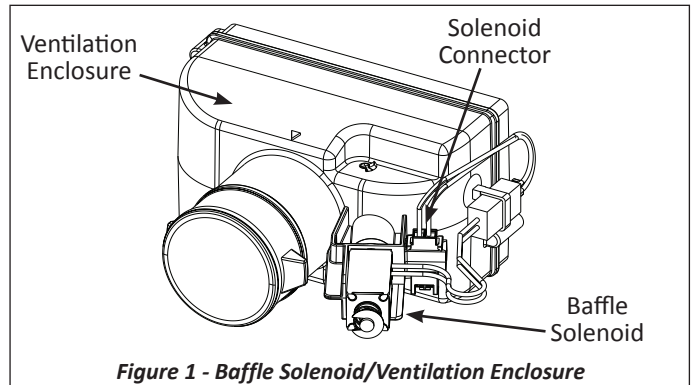

Figure 1 - Baffle Solenoid/Ventilation Enclosure

TEST #14: Vent Baffle Solenoid (on some models)

This test is performed if the vent baffle solenoid does not activate.

1. Check rear vent for obstruction that could prevent the fan baffle from opening.
2. Unplug washer or disconnect power.
3. Remove the top panel to access the machine electronics.
4. Visually check that connector **J9** is inserted all the way into the ACU (refer to ACU diagram on page 3-7). Also check that the solenoid harness is securely connected to the solenoid.
 - If visual check passes, go to step 6.
 - If connector is not inserted properly, reconnect **J9** and repeat step 2.
5. With an ohmmeter, check harness for continuity between the solenoid and the ACU (see Figures 1 & 2).
 - If there is continuity, go to step 7.
 - If there is no continuity, replace the upper machine harness and repeat step 2.

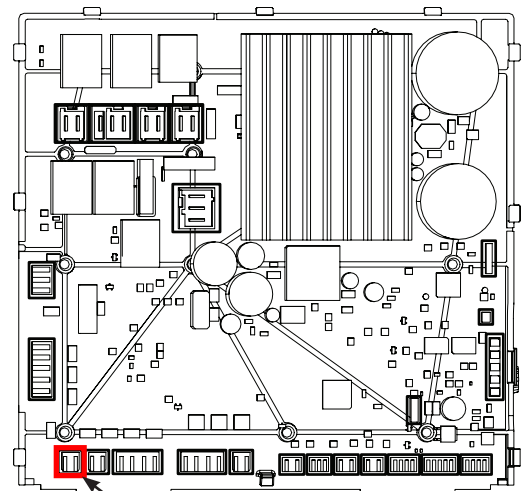

Figure 2 - Location of Baffle Solenoid Connector on ACU

VENT BAFFLE SOLENOID

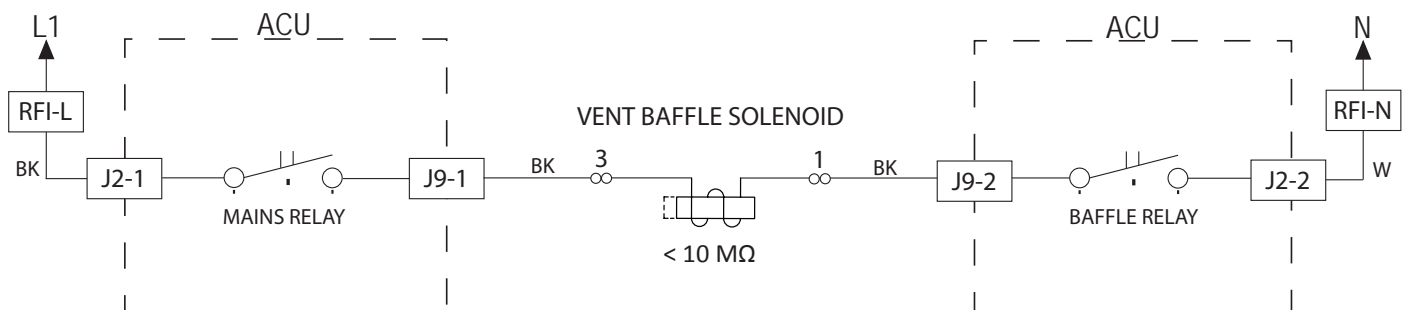

Figure 3 - Vent Baffle Solenoid Strip Circuit

For Service Technician Use Only

⚠ WARNING



Electrical Shock Hazard

Disconnect power before servicing.

Replace all parts and panels before operating.

Failure to do so can result in death or electrical shock.

- If the resistance is far out of range or open, replace the Heater Channel Assembly. **NOTE:** The dry heater element cannot be replaced separately from the Heater Channel Assembly.

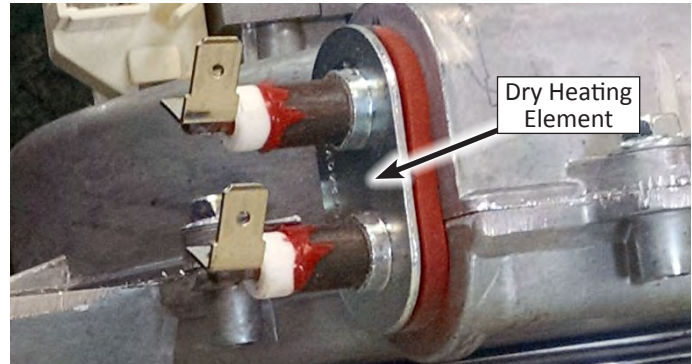

Figure 1 - Dry Heating Element

TEST #15: Dry Heating Element (on some models)

NOTE: The Dry Heating Element is deactivated on some models. May be available for future use.

This test checks the dry heating element, wiring, and ACU.

1. Unplug washer or disconnect power.
2. Remove top panel to access machine electronics.
3. Disconnect connector **J4** from the ACU. Refer to ACU diagram on page 3-7.
4. Using an ohmmeter, measure the resistance across pins 1 and 2 of connector **J4**.
 - If the resistance is 12.32–13.6Ω (1100W) or 30.1-34.9Ω (450W), the heating element and wiring are good; go to step 9.
 - If the resistance is open, go to step 5.
5. Remove top panel to access the dry heating element.
6. Disconnect the wire connectors from the dry heating element. See Figure 1.
7. Using an ohmmeter, measure the resistance across the two heating element terminals.
 - If the resistance is 12.32–13.6Ω (1100W) or 30.1-34.9Ω (450W), the dry heating element is good; go to step 8.

8. Check harness continuity between the **J4** on the ACU and the two dry heater terminals.
 - If the harness shows open, replace upper harness.
 - If harness continuity is good, go to step 9.
9. If the preceding steps did not correct the heating element problem, replace the ACU.

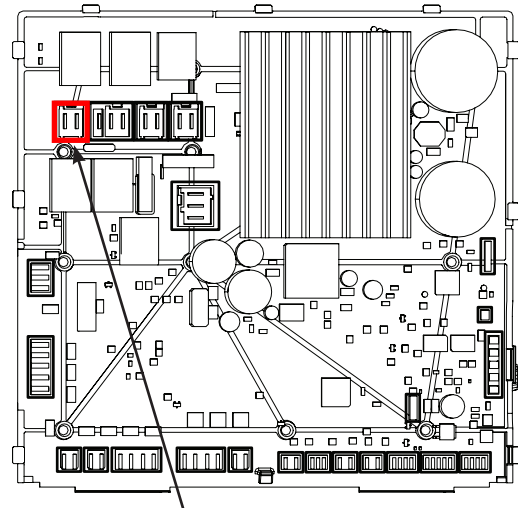

Figure 2 - Location of Dry Heater Connector on ACU

DRY HEATING ELEMENT

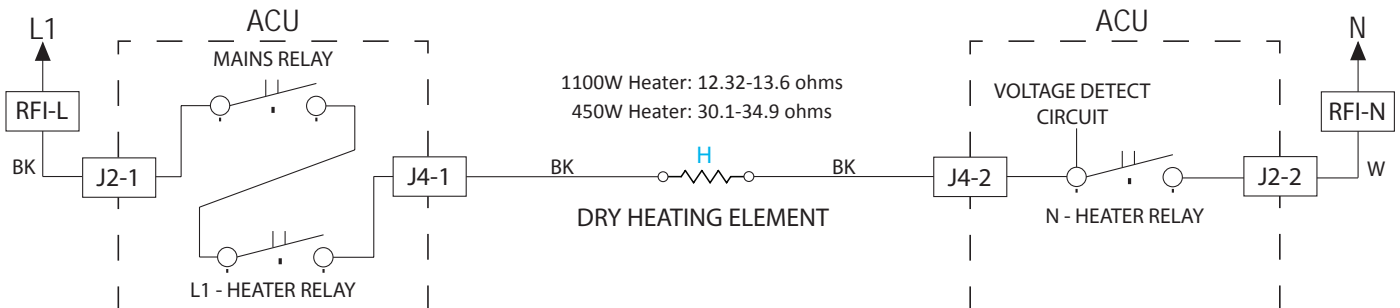



Figure 3 - Dry Heating Element Strip Circuit

For Service Technician Use Only

⚠ WARNING



Electrical Shock Hazard
 Disconnect power before servicing.
 Replace all parts and panels before operating.
 Failure to do so can result in death or electrical shock.

TEST #16: DRY TEMPERATURE SENSOR (on some models)

This test checks the temperature sensor, wiring, and ACU.

NOTE: Begin with an empty washer at ambient temperature.

1. Unplug washer or disconnect power.
2. Remove the top panel to access the machine electronics.
3. Remove connector **J13** from the ACU and measure the resistance between J13-1 and J13-3 at the connector. The following table gives temperatures and their associated resistance values.

| THERMISTOR SENSOR RESISTANCE | | |
|------------------------------|-----|--------------------|
| Approx. Temperature | | Approx. Resistance |
| F° | C° | (KΩ) |
| -4 | -20 | 183.4 |
| 14 | -10 | 107.2 |
| 32 | 0 | 63.8 |
| 59 | 15 | 31.1 |
| 77 | 25 | 20.0 |
| 86 | 30 | 16.2 |
| 104 | 40 | 10.7 |

| THERMISTOR SENSOR RESISTANCE | | |
|------------------------------|-----|--------------------|
| Approx. Temperature | | Approx. Resistance |
| 122 | 50 | 7.2 |
| 140 | 60 | 5.0 |
| 158 | 70 | 3.5 |
| 176 | 80 | 2.5 |
| 194 | 90 | 1.8 |
| 212 | 100 | 1.3 |
| 248 | 120 | 0.7 |
| 302 | 150 | 0.4 |

- If the resistance is infinite or close to zero, go to step 4.
 - If it is within range, go to step 7.
4. Disconnect the dry temperature sensor connector from the NTC.
 5. Using an ohmmeter, measure the resistance across pins 1 and 2 of the dry temperature sensor.
 - If the resistance is within the specified range, the sensor is good; replace the main harness.
 - If the resistance is far out of range or open, replace the temperature sensor.
 6. If the preceding steps did not correct the dry temperature sensor problem, replace the ACU.

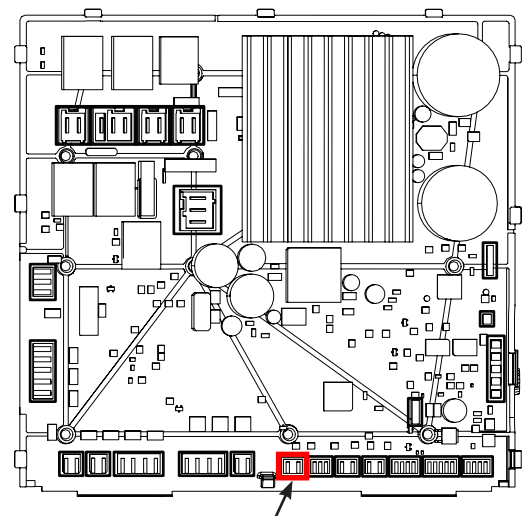

Figure 1 - Location of Dry NTC Connector on ACU

DRY TEMPERATURE SENSOR (NTC)

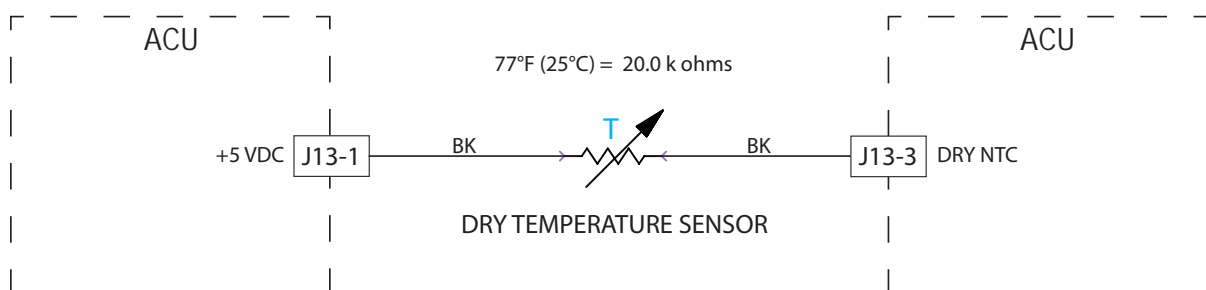



Figure 2 - Dry Temperature Sensor (NTC) Strip Circuit

For Service Technician Use Only

⚠ WARNING



Electrical Shock Hazard
Disconnect power before servicing.
Replace all parts and panels before operating.
Failure to do so can result in death or electrical shock.

TEST #17: Dry Blower Motor (on some models)

This test checks the dry blower motor and wiring.

1. Check the dry blower motor and electrical connections by performing the “Component Activation Test” on page 2-11 (LCD models only). The following steps assume that this step was unsuccessful.
2. Unplug washer or disconnect power.
3. Remove the top panel to access the machine electronics.
4. Visually check that connector **J12** is inserted all the way into the ACU (refer to ACU diagram on page 3-7). Also check that the blower motor harness is securely connected to the motor.
 - If visual check passes, go to step 5.
 - If connector is not inserted properly, reconnect **J12** and repeat step 1.
5. With an ohmmeter, check harness for continuity between the blower motor and the ACU.
 - If there is continuity, go to step 6.
 - If there is no continuity, replace the upper machine harness and repeat step 1.
6. With an ohmmeter, measure the resistance across the two blower motor terminals (see Figure 1). Resistance should be **9.0–10.6 Ω**.

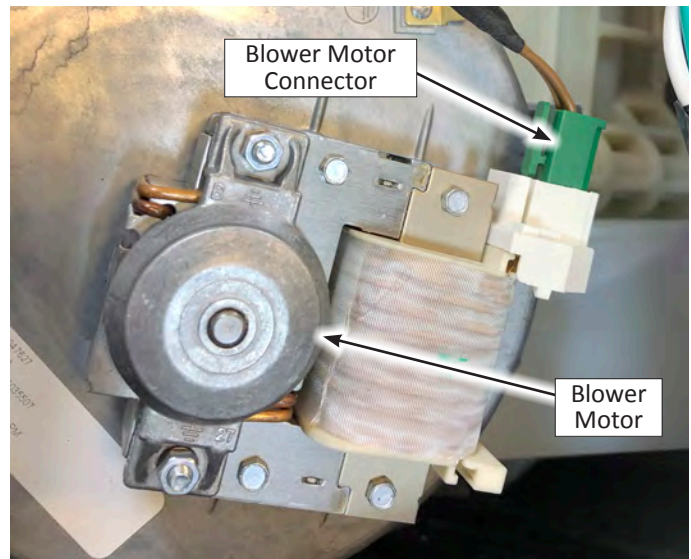

Figure 1 - Dry Blower Motor

- If resistance is **9.0–10.6 Ω**, go to step 7.
 - If the resistance is much less or much greater than **9.0–10.6 Ω**, replace the Heater Channel Assembly. **NOTE:** The blower motor cannot be replaced separately from the Heater Channel Assembly.
7. Remove the Heater Channel Assembly.
 8. Confirm that the blower wheel is not obstructed and turns freely.
 - If the blower wheel is obstructed, remove debris and re-assemble Heater Channel Assembly to washer.
 - If the blower wheel is not obstructed but does not turn freely, replace the Heater Channel Assembly. **NOTE:** The blower motor cannot be replaced separately from the Heater Channel Assembly.
 - If the blower wheel turns freely, replace the ACU.
 9. Perform the “Quick Service Cycle” on page 2-12 (LCD models only) to verify repairs.

DRY BLOWER MOTOR

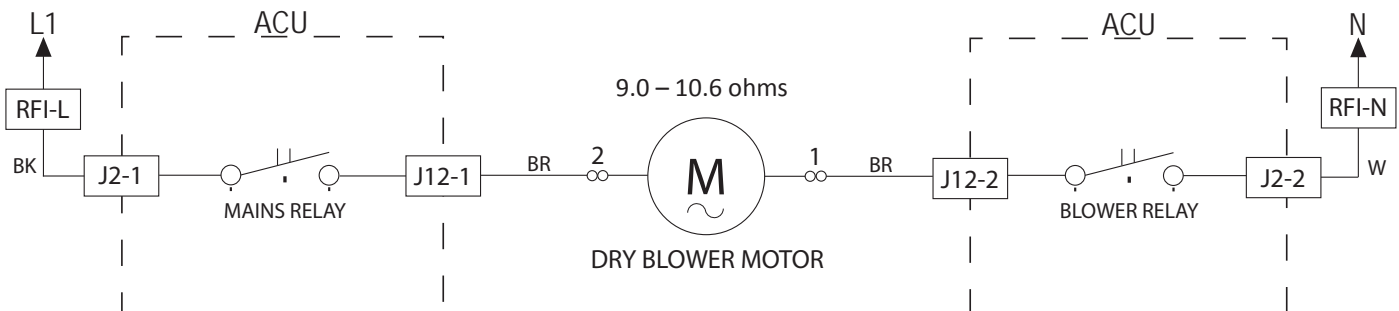

Figure 2 - Dry Blower Motor Strip Circuit

Section 4: Component Access

This section provides service parts, assemblies, and component locations for the “Whirlpool & Maytag Front-Load Washers.”

- Removing the Top Panel
- Replacing the Rear Panel
- Removing the Water Level Switch
- Removing the RFI Filter
- Removing the Drum Light (on some models)
- Removing the DVT Fan/Vent Assembly (on some models)
- Removing the Water Inlet Valves
- Removing the Appliance Control Unit (ACU)
- Removing the Top Rear Bracket
- Removing the Wash Heater/Thermistor Assembly
- Removing the Dryer Heater Channel Assembly (on some models)
- Removing the Condenser Duct (on some models)
- Removing the Door Assembly
- Removing the Door Lock Assembly
- Removing the Front Console
- Removing the Front Panel
- Removing the Single Dose Dispenser Assembly
- Removing the Direct Drive Motor
- Removing the Bulk Dispense Assembly (on some models)
- Removing the Drain/Recirculation Pumps
- Removing the Tub Assembly

Removing the Top Panel

⚠ WARNING



Electrical Shock Hazard

Disconnect power before servicing.

Replace all parts and panels before operating.

Failure to do so can result in death or electrical shock.

To Remove the Top Panel

1. Unplug washer or disconnect power.
2. Turn off water supply to washer.
3. Disconnect hot and cold water inlet hoses and remove the drain hose from the standpipe or laundry tub.
4. Using either a ¼" hex-head, or T20 Torx driver, remove the three (3) screws securing the top panel to the washer. See Figure 1.



Figure 1

5. Lift-up the rear part of the top panel and slide panel back to remove.
6. Reverse procedure to reinstall Top Panel.

Removing the Rear Panel

⚠ WARNING



Electrical Shock Hazard
Disconnect power before servicing.
Replace all parts and panels before operating.
Failure to do so can result in death or electrical shock.

To Remove the Rear Panel

1. Unplug washer or disconnect power.
2. Turn off water supply to washer.
3. Disconnect hot and cold water inlet hoses and remove the drain hose from the standpipe or laundry tub.
4. Using either a ¼" hex-head, or T20 Torx driver, remove the fourteen (14) screws securing the rear-top panel to the washer (illustrated in Figure 1).



Figure 1

5. Lift-up on rear panel and remove from washer.
6. Reverse procedure to reinstall Rear Panel.

Removing the Water Level Switch

⚠ WARNING



Electrical Shock Hazard

Disconnect power before servicing.

Replace all parts and panels before operating.

Failure to do so can result in death or electrical shock.

7. Twist Water Level Switch 90 degrees to remove from side panel.
8. Remove the hose from the pressure switch (see Figure 1).
9. Reverse procedure to reinstall water level switch.

To Remove the Water Level Switch

1. Unplug washer or disconnect power.
2. Turn off water supply to washer.
3. Disconnect hot and cold water inlet hoses and remove the drain hose from the standpipe or laundry tub.
4. Perform the procedures on page 4-2, "Removing the Top Panel" prior to performing the following steps.
5. The pressure switch is located on the right panel toward the front.
6. Disconnect the pressure switch harness (see Figure 1). Press the clip away from the harness and slide out connector.

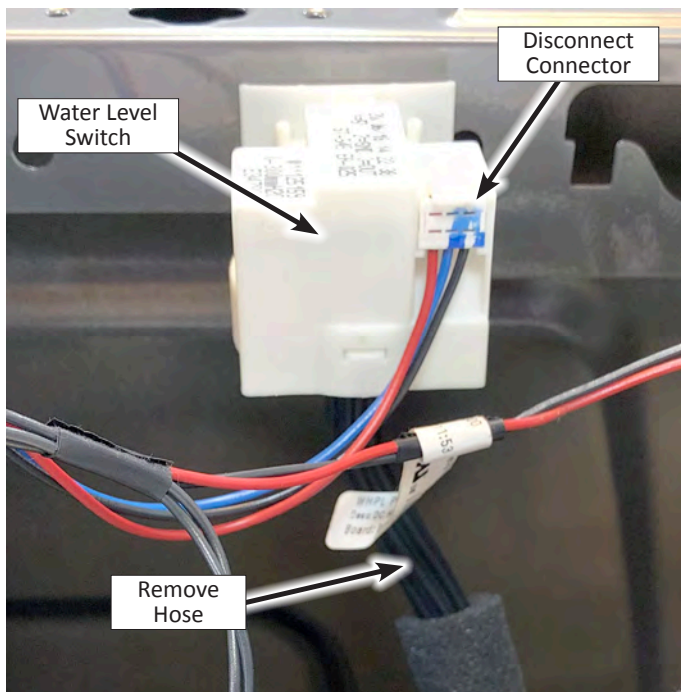



Figure 1 - Water Level Switch

Removing the RFI Filter

⚠ **WARNING**



Electrical Shock Hazard

Disconnect power before servicing.

Replace all parts and panels before operating.

Failure to do so can result in death or electrical shock.

6. Unclip the harness clip and slide RFI Filter to disengage tabs from top of rear bracket. Remove RFI filter (see Figure 1).
7. With filter removed, disconnect the two (2) AC input terminals and the one AC output connector. Remove RFI filter from washer.

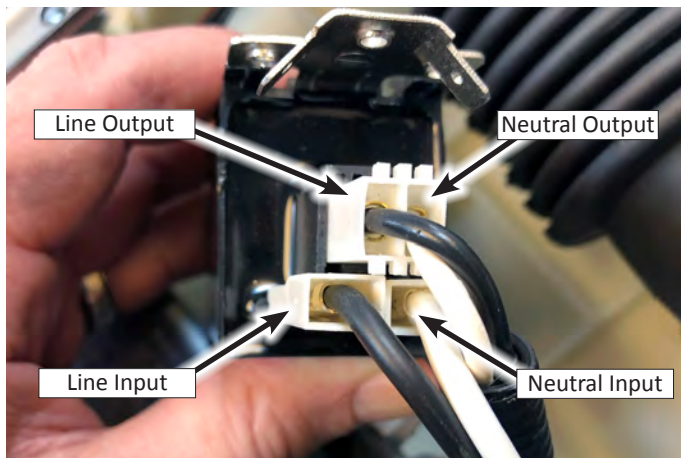

Figure 2

To Remove the RFI Filter

1. Unplug washer or disconnect power.
2. Turn off water supply to washer.
3. Disconnect hot and cold water inlet hoses and remove the drain hose from the standpipe or laundry tub.
4. Perform the procedures on page 4-2, "Removing the Top Panel" prior to performing the following steps.
5. Using either a 1/4" hex-head, or T20 Torx driver, remove the "green" ground screw and the one screw securing the RFI filter to the rear bracket. See Figure 1.

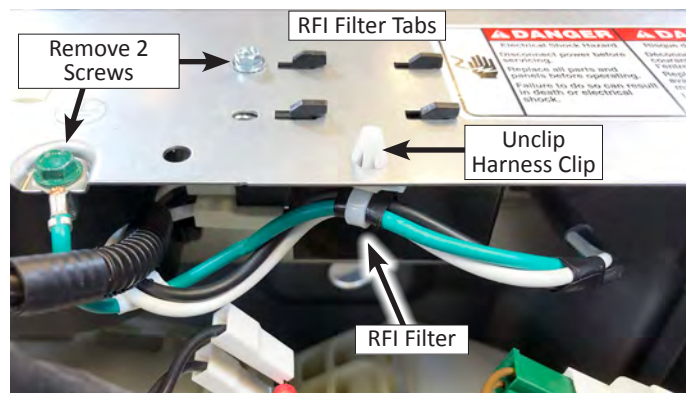

Figure 1

8. Reverse procedure to reinstall the RFI Filter.

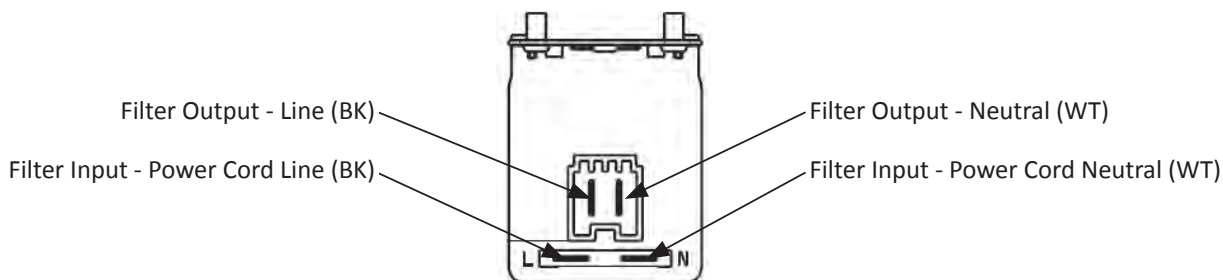



Figure 3 - Electrical Connections

Removing the Drum Light (on some models)

⚠ WARNING



Electrical Shock Hazard
Disconnect power before servicing.
Replace all parts and panels before operating.
Failure to do so can result in death or electrical shock.

To Remove the Drum Light (on some models)

1. Unplug washer or disconnect power.
2. Turn off water supply to washer.
3. Disconnect hot and cold water inlet hoses and remove the drain hose from the standpipe or laundry tub.
4. Perform the procedures on page 4-2, "Removing the Top Panel" prior to performing the following steps.
5. Disconnect the Drum Light connector (see Figure 1).

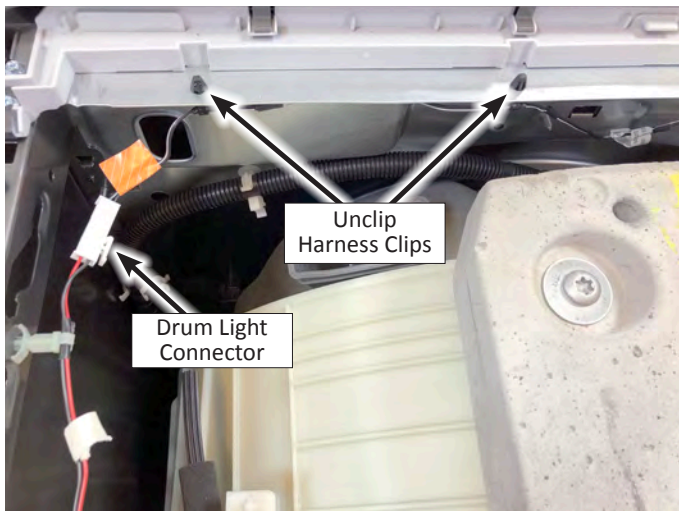

Figure 1

6. Unclip the three (3) harness clips (see Figures 1 & 2).

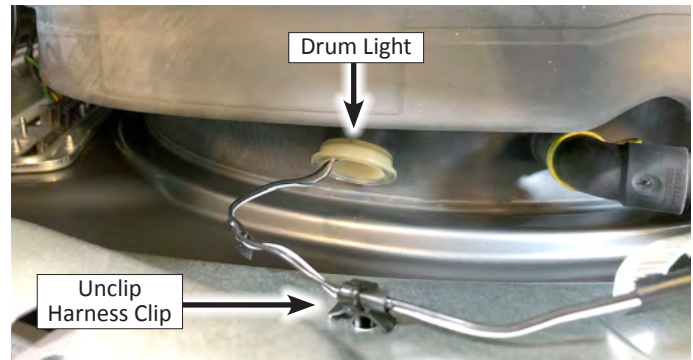



Figure 2

7. Open the washer door and push the drum light out of the top of the bellows. See Figure 2.
8. Remove Drum Light from washer.
9. Reverse procedure to reinstall drum light.

Removing the DVT Fan/Vent Assembly (on some models)

⚠ WARNING



Electrical Shock Hazard
 Disconnect power before servicing.
 Replace all parts and panels before operating.
 Failure to do so can result in death or electrical shock.

To Remove the DVT Fan/Vent Assembly (on some models)

1. Unplug washer or disconnect power.
2. Turn off water supply to washer.
3. Disconnect hot and cold water inlet hoses and remove the drain hose from the standpipe or laundry tub.
4. Perform the procedures on page 4-2, "Removing the Top Panel" prior to performing the following steps.
5. Disconnect tub hose from DVT enclosure (see Figure 1).

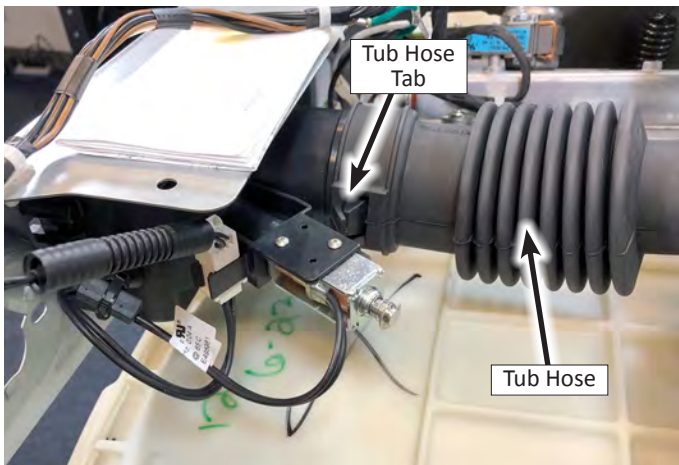

Figure 1

6. Disconnect baffle solenoid or fan connector (see Figure 2).
NOTE: Baffle Solenoid is shown in figure below. Some models may have a fan in the DVT enclosure instead of a baffle solenoid.

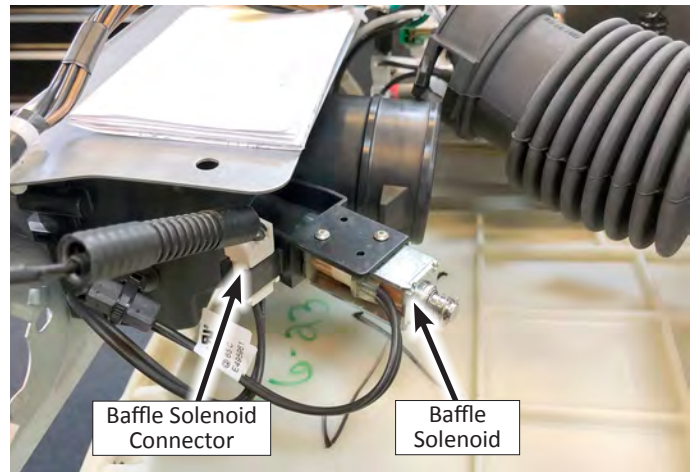

Figure 2

7. Using a T20 Torx driver, remove the two (2) screws securing the DVT enclosure to the rear bracket. See Figure 3.

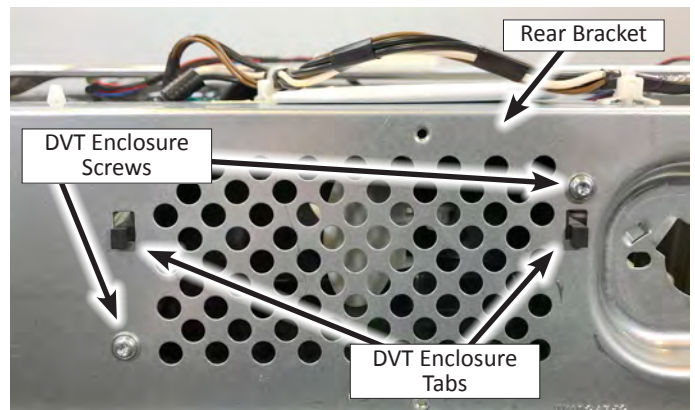



Figure 3

8. Lift up on DVT enclosure to disengage the two tabs from rear bracket. Remove DVT enclosure from washer.
9. Reverse procedure to reinstall DVT Fan/Vent Assembly.

Removing the Water Inlet Valves

⚠ WARNING



Electrical Shock Hazard
Disconnect power before servicing.
Replace all parts and panels before operating.
Failure to do so can result in death or electrical shock.

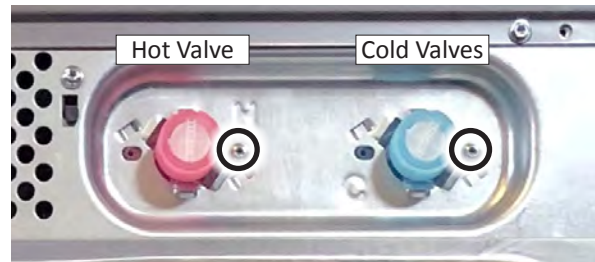

Figure 2

To Remove the Water Inlet Valves (Hot & Cold)

1. Unplug washer or disconnect power.
2. Turn off water supply to washer.
3. Disconnect hot and cold water inlet hoses and remove the drain hose from the standpipe or laundry tub.
4. Perform the procedures on page 4-2, "Removing the Top Panel" prior to performing the following steps.
5. Disconnect the water inlet valve connector(s) (see Figure 1).

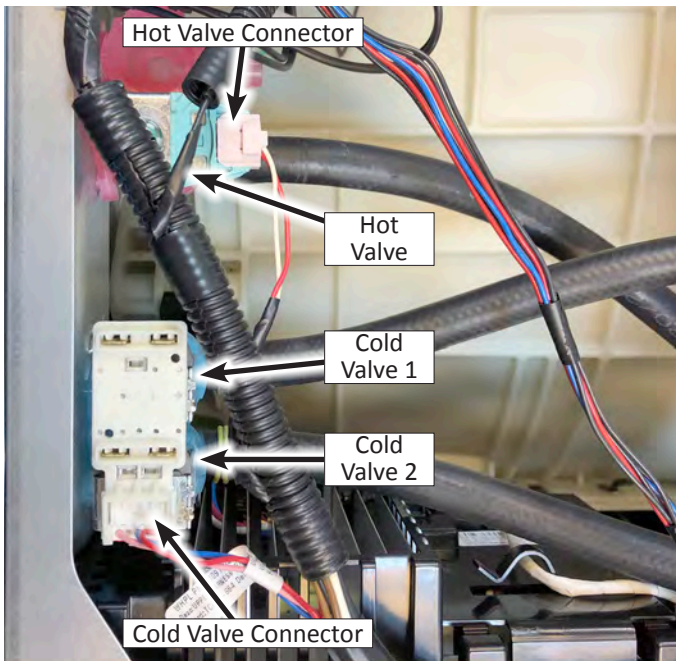

Figure 1

6. Using a T20 Torx driver, remove the screw(s) securing the valve(s) to the rear bracket (see Figure 2).

Water Inlet Hose Connections

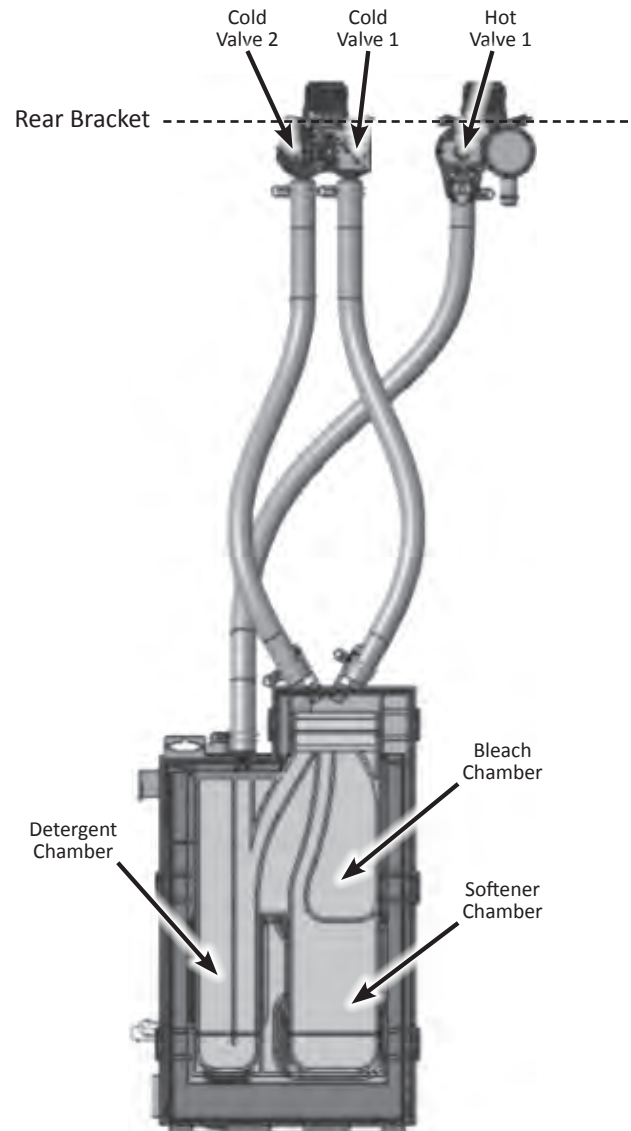

Figure 3

Removing the Appliance Control Unit (ACU)

⚠ WARNING



Electrical Shock Hazard
 Disconnect power before servicing.
 Replace all parts and panels before operating.
 Failure to do so can result in death or electrical shock.

To Remove the Appliance Control Unit (ACU)

IMPORTANT: Electrostatic Discharge (ESD) Sensitive Device. Failure to follow the ESD precautions outlined at the beginning of Section 6 "Testing" may destroy, damage, or weaken the ACU.

1. Unplug washer or disconnect power.
2. Turn off water supply to washer.
3. Disconnect hot and cold water inlet hoses and remove the drain hose from the standpipe or laundry tub.
4. Perform the procedures on page 4-2, "Removing the Top Panel" prior to performing the following steps.
5. Perform the procedures on page 4-3, "Removing the Rear Panel" prior to performing the following steps.

See page 4-8, "Removing the Water Inlet Valves," for the following three steps:

6. Disconnect the hot and cold water inlet valve harnesses.
7. Remove the screws securing the water inlet valves to the rear bracket.
8. Rotate the valves to disengage from the rear bracket and push them into the cabinet. Move both hot and cold valves and hoses away from the ACU. **IMPORTANT: Do not stress the hose fittings on the dispenser.**
9. Remove the three (3) harness clips as shown.

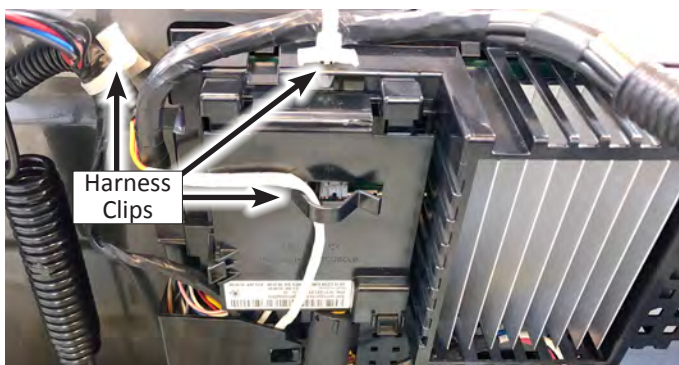

Figure 1

10. Open the three (3) connector covers (as shown in Figure 2) and disconnect all connectors from the ACU.

NOTE: Although, the connectors are keyed, it may be advisable to take pictures of the connectors for reference.

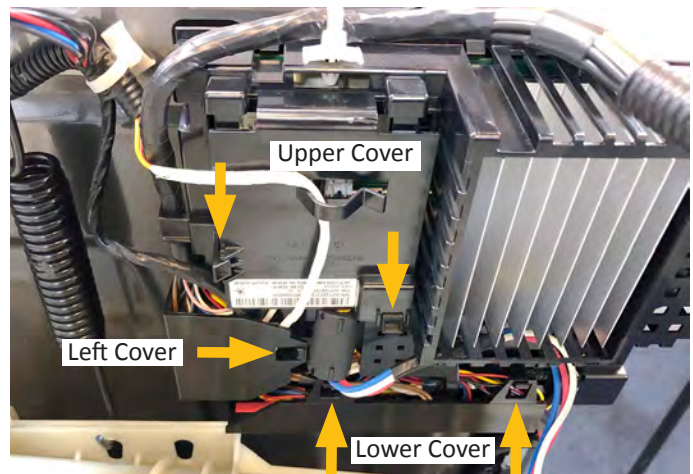

Figure 2

11. Using a 5/16" nut driver, remove the ACU retainer screw from the rear left panel (see Figure 3).

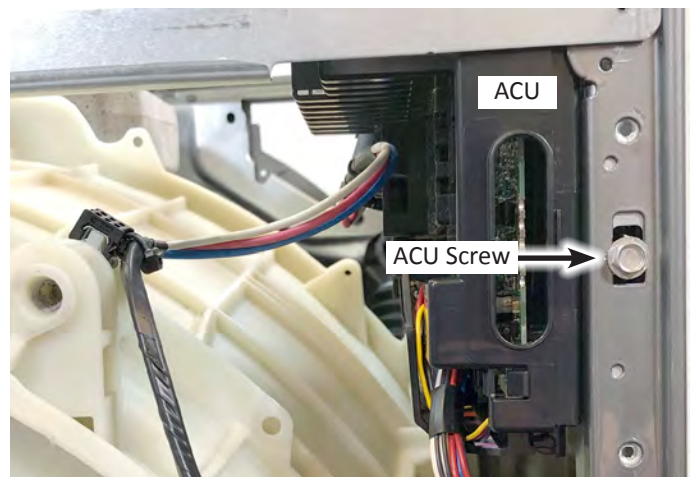



Figure 3

12. Slide the ACU forward to disengage tabs from left panel. Remove from washer.
13. Reverse procedure to reinstall the Appliance Control Unit.

NOTE: Reference the ACU Board diagram on page 3-7 "ACU Connectors & Pinouts - Figure 2" for connector identification and locations

Removing the Top Rear Bracket

⚠ WARNING



Electrical Shock Hazard

Disconnect power before servicing.

Replace all parts and panels before operating.

Failure to do so can result in death or electrical shock.

See page 4-8, “Removing the Water Inlet Valves,” for the following three steps:

8. Disconnect the hot and cold water inlet valve harnesses.
9. Remove the screws securing the water inlet valves to the rear bracket.
10. Rotate the valves to disengage from the rear bracket and push them into the cabinet. **IMPORTANT: Do not stress the hose fittings on the dispenser.**
11. Using either a ¼” hex-head, or T20 Torx driver, remove the six (6) screw securing the Rear Bracket to the washer. See Figure 1 below.
12. Using needle nose pliers, remove harness clips from rear bracket (see Figure 2).

To Remove the Rear Bracket

1. Unplug washer or disconnect power.
2. Turn off water supply to washer.
3. Disconnect hot and cold water inlet hoses and remove the drain hose from the standpipe or laundry tub.
4. Perform the procedures on page 4-2, “Removing the Top Panel” prior to performing the following steps.
5. Perform the procedures on page 4-3, “Removing the Rear Panel” prior to performing the following steps.
6. Perform the procedures on page 4-5, “Removing the RFI Filter” prior to performing the following steps.
7. Performing the procedures on page 4-7 “Removing the DVT Fan/Vent Assembly (if exists)” prior to performing the following steps.

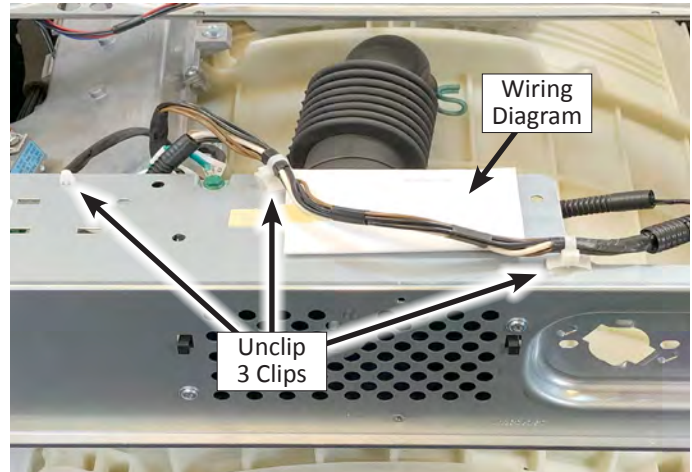

Figure 2

13. Remove rear bracket from washer.
14. Reverse procedure to reinstall Rear Bracket.

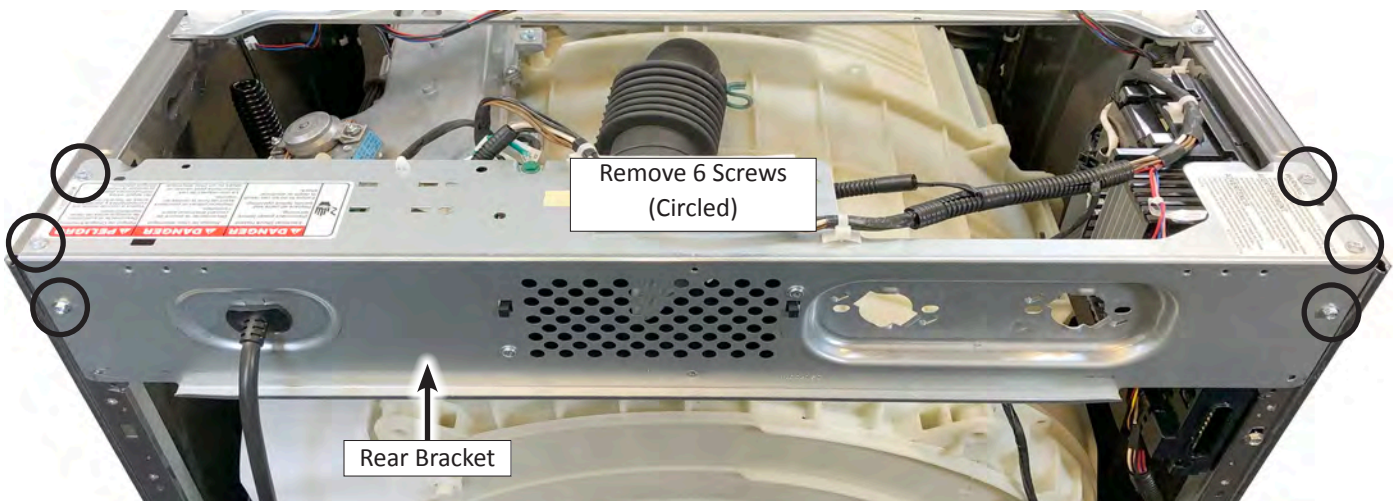

Figure 1

Removing the Wash Heater/Thermistor Assembly

⚠ WARNING



Electrical Shock Hazard
Disconnect power before servicing.
Replace all parts and panels before operating.
Failure to do so can result in death or electrical shock.

Reinstallation Notes

1. For reinstallation, make sure the new heater is going to be put underneath the clamp that is fixed on the bottom of the tub.
2. Make sure the heater is torqued down to $4.5\text{Nm} \pm 0.5\text{Nm}$.
3. Turn the drum slowly after the new heater has been installed, to make sure the heater is not touching the drum.
4. Run cycle for leak testing.

To Remove the Wash Heater/Thermistor Assembly

1. Unplug washer or disconnect power.
2. Turn off water supply to washer.
3. Disconnect hot and cold water inlet hoses and remove the drain hose from the standpipe or laundry tub.
4. Perform the procedures on page 4-3, "Removing the Rear Panel" prior to performing the following steps.
5. Remove the connector from the Wash NTC and the two wire terminals from the Wash Heater (see Figure 1).

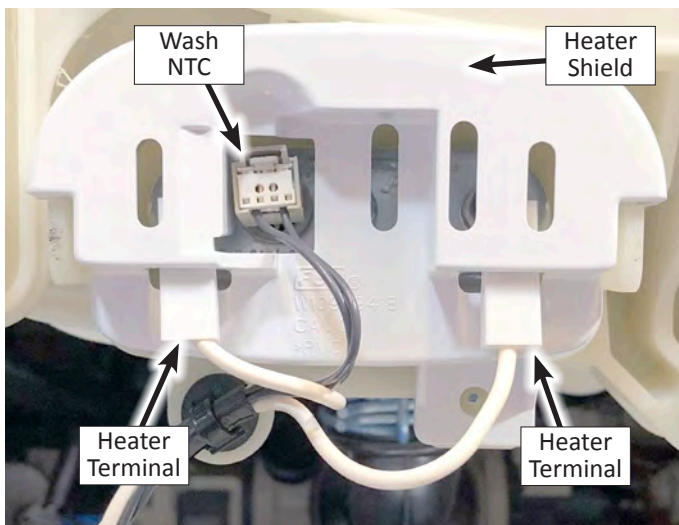



Figure 1

6. Remove the heater shield.
7. Using a 10mm socket, loosen the compression nut (to the right of the NTC), but do not remove it completely.
8. Gently pull the Heater/Thermistor Assembly from the tub.

Removing the Dryer Heating Channel Assembly (some models)

⚠ WARNING



Electrical Shock Hazard
Disconnect power before servicing.
Replace all parts and panels before operating.
Failure to do so can result in death or electrical shock.

10. From the rear of the washer, using a Phillips screwdriver, loosen the clamp screw securing the heater channel to the condenser duct. See Figure 2.

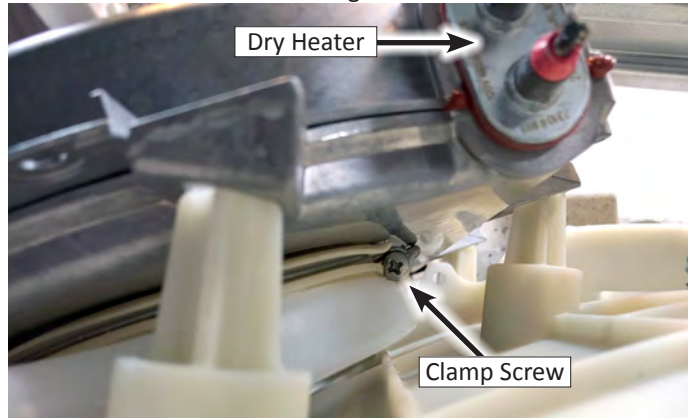

Figure 2

To Remove the Dryer Heating Channel Assembly (on some models)

1. Unplug washer or disconnect power.
2. Turn off water supply to washer.
3. Disconnect hot and cold water inlet hoses and remove the drain hose from the standpipe or laundry tub.
4. Perform the procedures on page 4-2, "Removing the Top Panel" prior to performing the following steps.
5. Perform the procedures on page 4-3, "Removing the Rear Panel" prior to performing the following steps.
6. Remove the screws securing the rear bracket to the washer (see page 4-10). It is not necessary to remove the rear bracket completely.
7. Remove connectors from Blower Motor, Dry Heater, and Dry NTC (Thermistor). See Figure 1.
8. Unclip the two wire clips as shown by arrows in Figure 1 .
9. Use a 5/16" nut driver or socket to remove five (5) screws as circled in Figure 1 .

11. Cut the wide wire tie that secures the heater channel assembly to the bellows (see Figure 3).

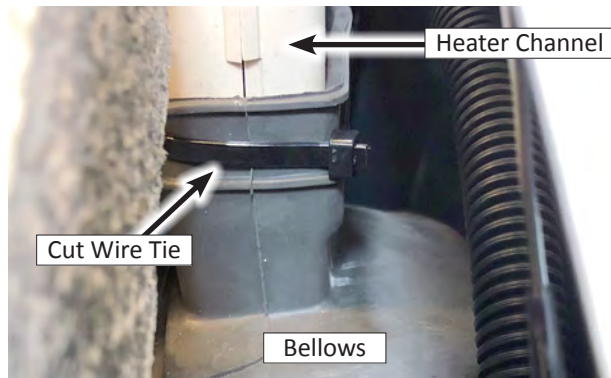

Figure 3

12. Lift up the heater channel assembly to disengage from the bellows and condenser duct. Carefully route the heater channel out the back of the washer.

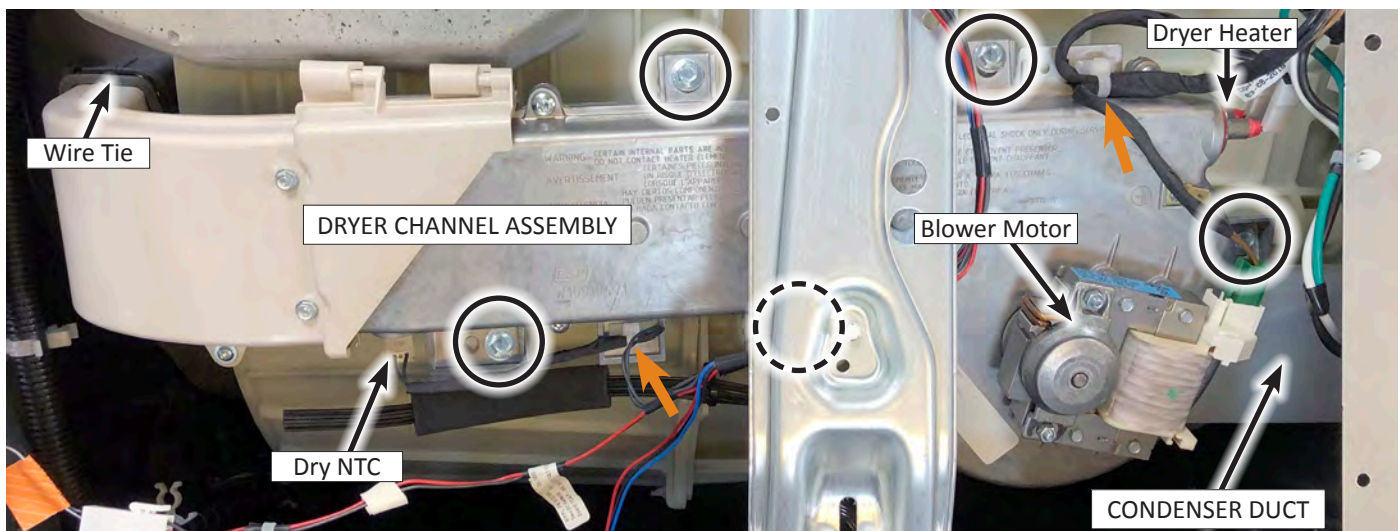

Figure 1 - Dryer Channel Assembly

Removing the Condenser Duct Assembly (on some models)

⚠ WARNING



Electrical Shock Hazard
 Disconnect power before servicing.
 Replace all parts and panels before operating.
 Failure to do so can result in death or electrical shock.

To Remove the Condenser Duct Assembly (on some models)

1. Unplug washer or disconnect power.
2. Turn off water supply to washer.
3. Disconnect hot and cold water inlet hoses and remove the drain hose from the standpipe or laundry tub.
4. Perform the procedures on page 4-2, "Removing the Top Panel" prior to performing the following steps.
5. Perform the procedures on page 4-3, "Removing the Rear Panel" prior to performing the following steps.
6. Perform the procedures on page 4-12, "Removing the Dryer Heater Channel Assembly" prior to performing the following steps.
7. At this point, the Condenser Duct Assembly should look like the example in Figure 1 below.

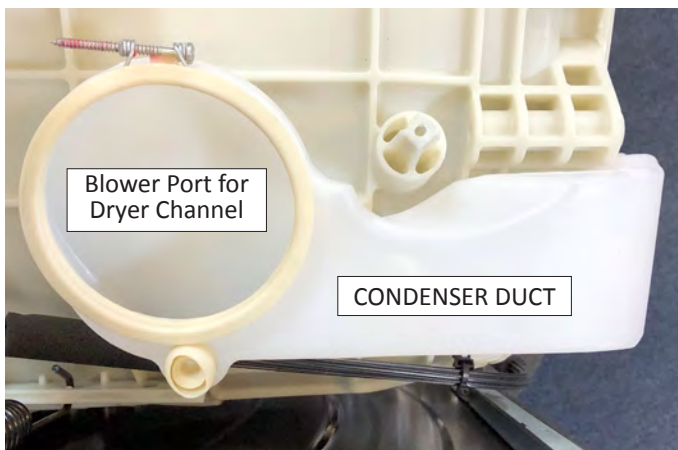

Figure 1

8. Using a Phillips screwdriver, loosen the clamp screw securing the condenser duct to the rear of the tub assembly. See Figure 2.
9. Using a T20 Torx driver, remove the screw and washer as shown in Figure 2.

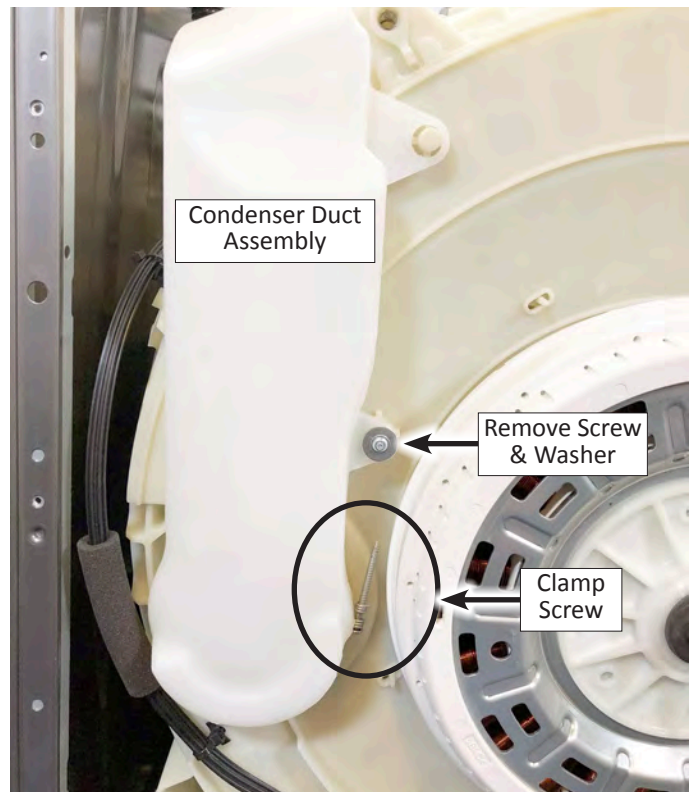

Figure 2

10. Pull the condenser duct away from the tub assembly and remove from washer.
11. Remove the lint screen (see Figure 3). **NOTE:** Be sure the three tabs point downward when reinstalling lint screen.

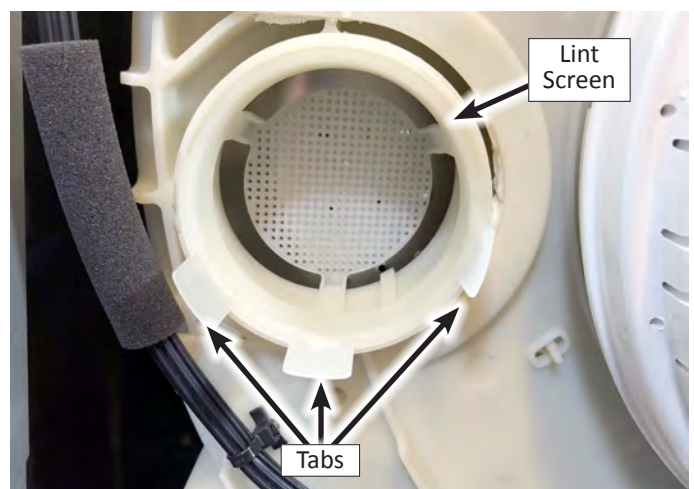

Figure 3

Removing the Door Assembly

⚠ WARNING



Electrical Shock Hazard
Disconnect power before servicing.
Replace all parts and panels before operating.
Failure to do so can result in death or electrical shock.

To Remove the Door Assembly w/o HMI

1. Unplug washer or disconnect power.
2. Open door. Using a T25 Torx driver, remove the four (4) screws securing the door hinge to the front panel.
3. Lift up on the door assembly and remove from washer.

To Remove the Door Assembly w/HMI

1. Unplug washer or disconnect power.
2. Open door. Using T25 Torx driver, remove the center hinge screw as illustrated in Figure 1.



Figure 1

3. Open center hinge and disconnect door harness (see Figure 2).
4. Using a T25 Torx driver, remove the ground wire screw (see Figure 2).
5. Using a T25 Torx driver, remove the four (4) screws (circled in Figure 2) securing the door hinge to the front panel.

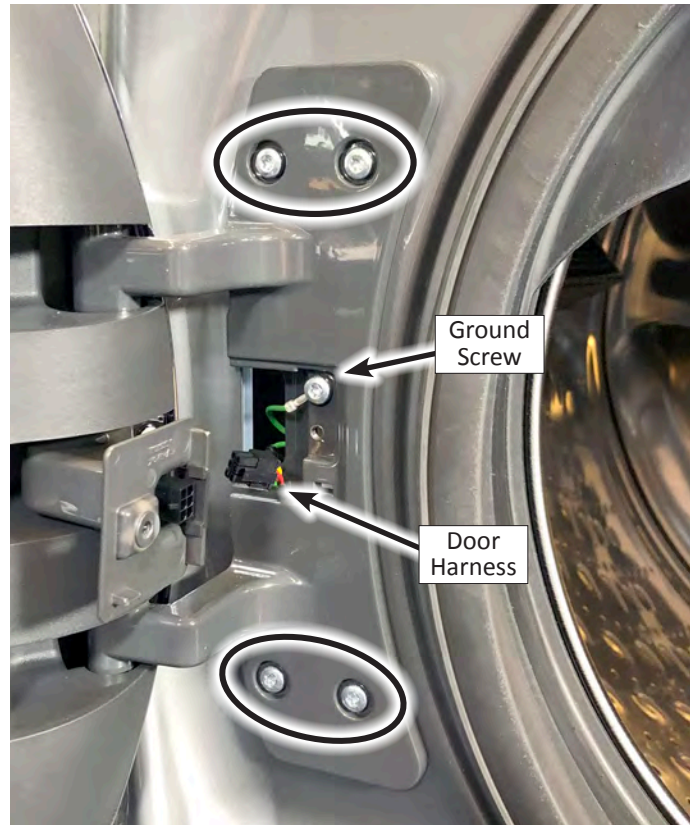

Figure 2

6. Lift up on the door assembly and remove from washer.
7. Reverse procedure to reinstall door to washer.

Removing the Door Lock Assembly

⚠ WARNING



Electrical Shock Hazard
 Disconnect power before servicing.
 Replace all parts and panels before operating.
 Failure to do so can result in death or electrical shock.

To Remove the Door Lock Assembly

1. Unplug washer or disconnect power.
2. Open washer door.
3. Using a small screwdriver or a pair of long-nosed pliers, pull the tension spring on the retaining wire out from around the front of the bellows and remove the wire. Remove the bellows tension spring.
4. Fold back the bellows on the right side of the door, next to the door lock assembly.
5. Using a T20 Torx driver, remove the two (2) screws securing the door lock assembly to the front panel.

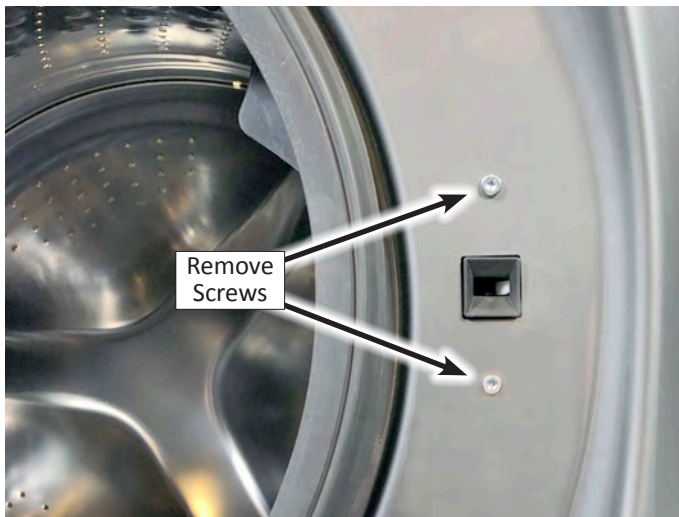

Figure 1

6. Reach in through the opening between the front panel and bellows and pull out the door lock assembly. See Figure 2.

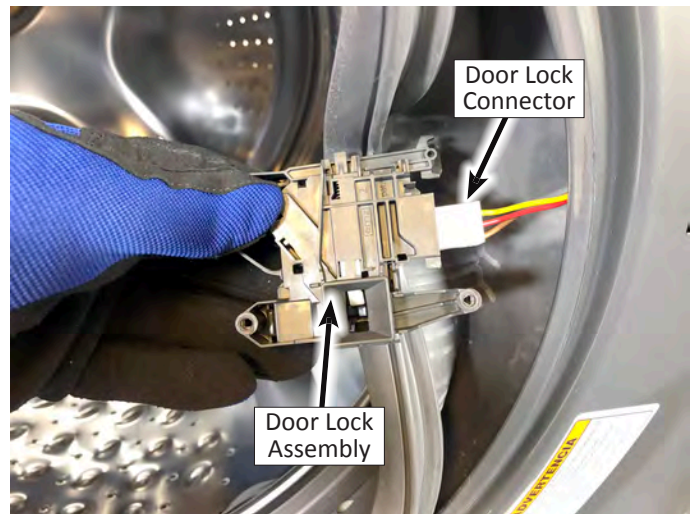

Figure 2

7. Disconnect the door lock connector and remove door lock assembly from washer.
8. Reverse procedure to reinstall the door lock assembly.

Removing the Front Console

WARNING



Electrical Shock Hazard
Disconnect power before servicing.
Replace all parts and panels before operating.
Failure to do so can result in death or electrical shock.

To Remove the Front Console

1. Unplug washer or disconnect power.
2. Turn off water supply to washer.
3. Disconnect hot and cold water inlet hoses and remove the drain hose from the standpipe or laundry tub.
4. Perform the procedures on page 4-2, "Removing the Top Panel" prior to performing the following steps.
5. Remove the single dose dispenser drawer.

6. Using a T20 Torx driver, remove the two (2) screws on both sides of the dispenser drawer opening (see Figure 1).

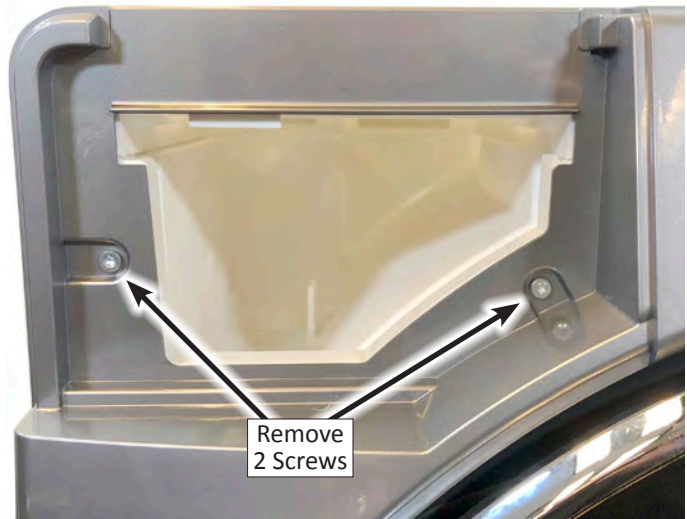

Figure 1

7. Using either a 1/4" hex-head, or T20 Torx driver, the two (2) screws securing the Front Console to the console bracket. See Figure 2 below..
8. Lift up on top edge of console to disengage the four (4) console tabs. Lift up and away from washer. See Figure 2 below.
9. Reverse procedure to reinstall the Front Console to washer.

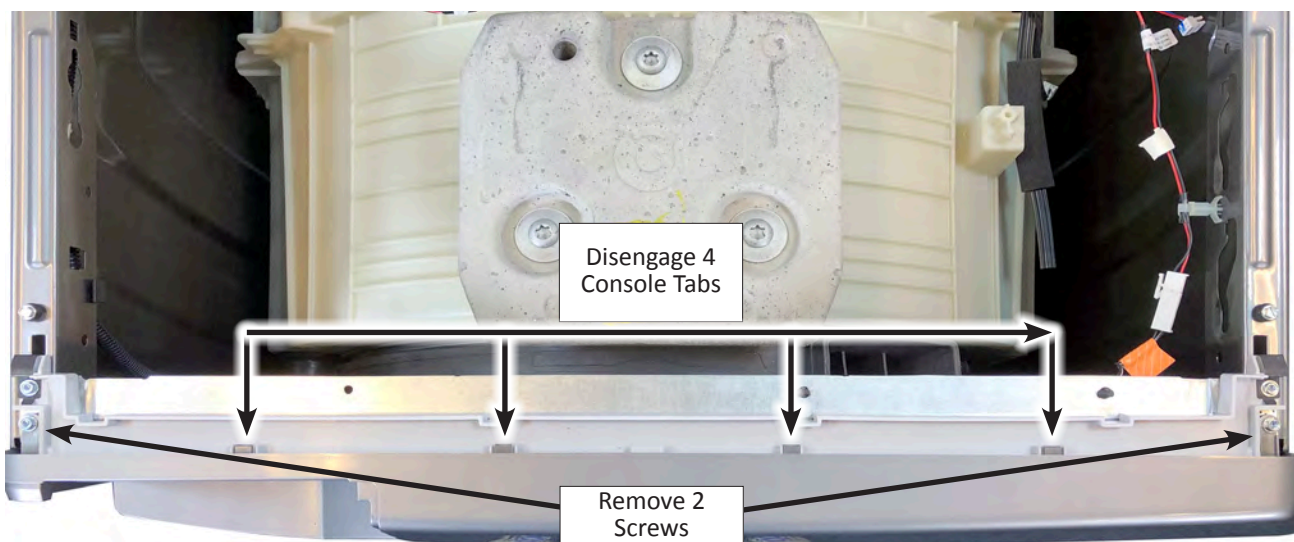

Figure 2 - Remove Front Console Screws

Removing the Front Panel

⚠ WARNING



Electrical Shock Hazard
Disconnect power before servicing.
Replace all parts and panels before operating.
Failure to do so can result in death or electrical shock.

To Remove the Front Panel

All Washers:

1. Unplug washer or disconnect power.
2. Turn off water supply to washer.
3. Disconnect hot and cold water inlet hoses and remove the drain hose from the standpipe or laundry tub.
4. Perform the procedures on page 4-2, "Removing the Top Panel" prior to performing the following steps.
5. Perform the procedures on page 4-14, "Removing the Door Assembly" prior to performing the following steps.
6. Perform the procedures on page 4-16, "Removing the Front Console" prior to performing the following steps.

Washers with a Bulk Dispenser Drawer (on some models):

7. Open the "Bulk Dispense" drawer by pulling on the handle at the base of the washer.
8. Remove the drawer by releasing the tab on each side. With your finger, push down the tab on the right side of drawer, and up on tab on left side of drawer. See Figure 1.

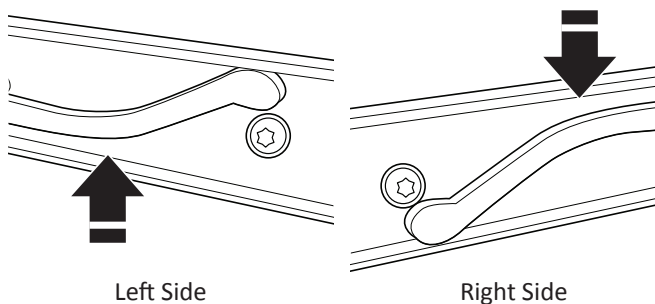

Figure 1

All Washers:

9. Using a small screwdriver or a pair of long-nosed pliers, pull the tension spring on the retaining wire out from around the front of the bellows and remove the wire. Detach the bellows from front panel.
10. Using a 1/4" nut driver, remove the four (4) screws at the bottom of the front panel. See Figure 2.
11. Using a 5/16" nut driver, remove the three (3) screws at the top of the front panel. See Figure 2.

Remove Three 5/16" Screws



Figure 2

12. Lift up on front panel and pull away from washer just enough to gain access to the door lock assembly.
13. Disconnect the door lock assembly harness and remove Front Panel from washer.
14. Reverse procedure to reinstall Front Panel to washer.

Removing the Single Dose Dispenser Assembly

⚠ WARNING



Electrical Shock Hazard
Disconnect power before servicing.
Replace all parts and panels before operating.
Failure to do so can result in death or electrical shock.

7. Perform the procedures on page 4-17, "Removing the Front Panel" prior to performing the following steps.
8. Reaching in from the front of the washer. Slide the "Dispenser Assembly Hose" clamp away from the dispenser. See Figure 1.
9. Slide the "Dispenser Assembly Hose" off of the single dose dispenser (see Figure 1).
10. Slide the single dose dispenser assembly back to disengage tabs from left-side panel. Remove dispenser from washer.
11. Reverse procedure to reinstall the Single Dose Dispenser Assembly. See Figure 2 to reference hose connections.

To Remove the Single Dose Dispenser Assembly

1. Unplug washer or disconnect power.
2. Turn off water supply to washer.
3. Disconnect hot and cold water inlet hoses and remove the drain hose from the standpipe or laundry tub.
4. Perform the procedures on page 4-2, "Removing the Top Panel" prior to performing the following steps.
5. Using pliers, slide the water inlet hose clamps away from the dispenser assembly (see Figure 1).
6. Remove the 3 hoses from the single dose dispenser (see Figure 1). **IMPORTANT: The water inlet hose fittings on the dispenser may break if the fittings are overstressed.**

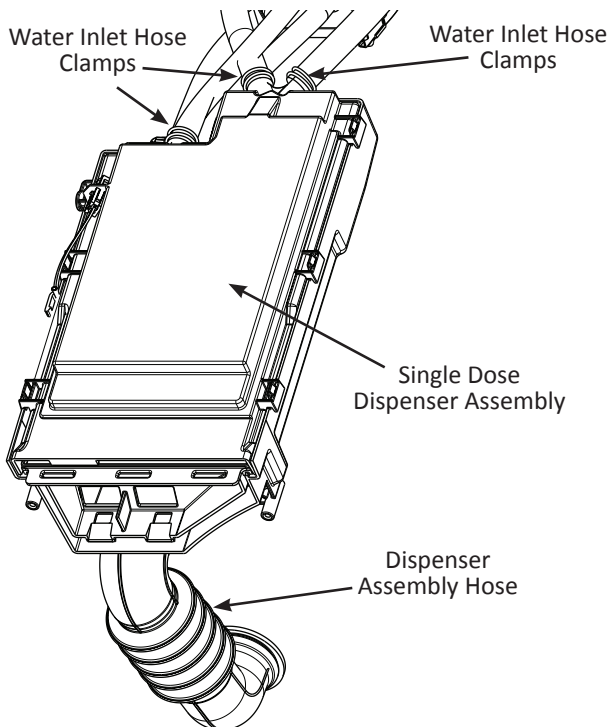
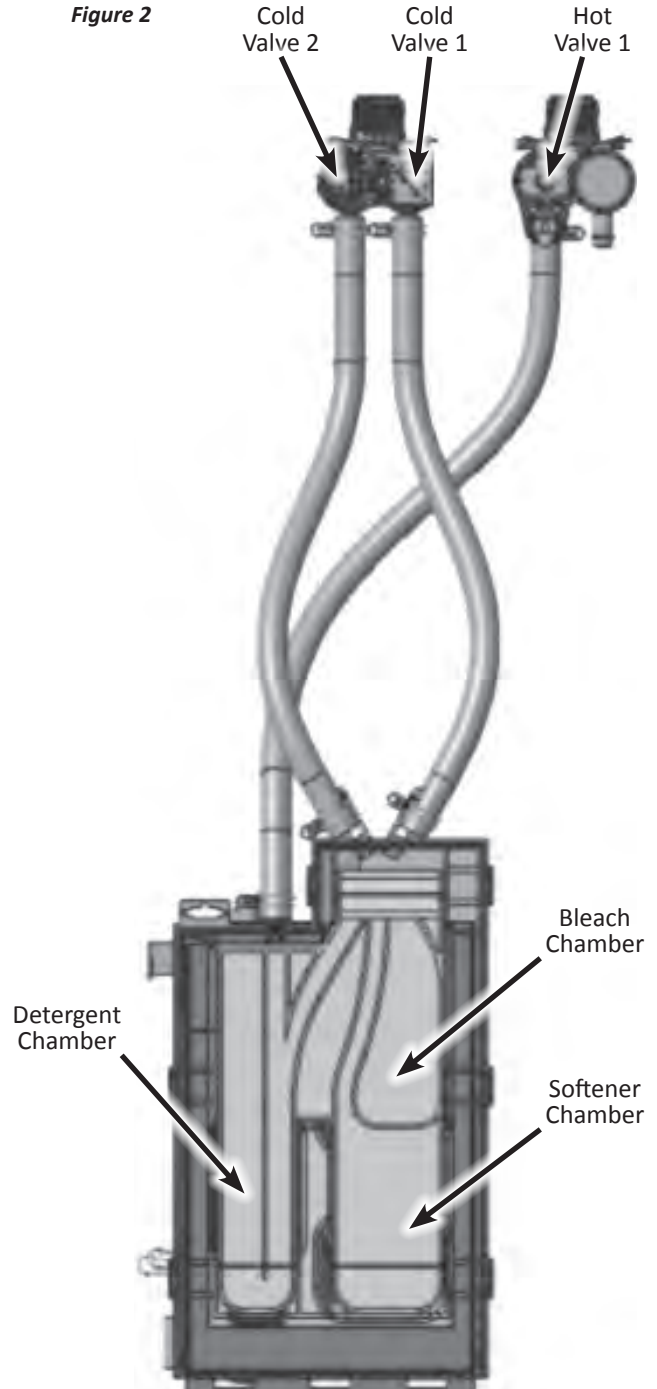



Figure 1

Figure 2



Removing the Direct Drive Motor

⚠ WARNING



Electrical Shock Hazard
 Disconnect power before servicing.
 Replace all parts and panels before operating.
 Failure to do so can result in death or electrical shock.

To Remove the Direct Drive Motor

1. Unplug washer or disconnect power.
2. Turn off water supply to washer.
3. Disconnect hot and cold water inlet hoses and remove the drain hose from the standpipe or laundry tub.
4. Perform the procedures on page 4-2, "Removing the Top Panel" prior to performing the following steps.
5. Perform the procedures on page 4-3, "Removing the Rear Panel" prior to performing the following steps.
6. Disconnect motor connector harness from J6 on the Appliance Control Unit (ACU) (see Figure 1).

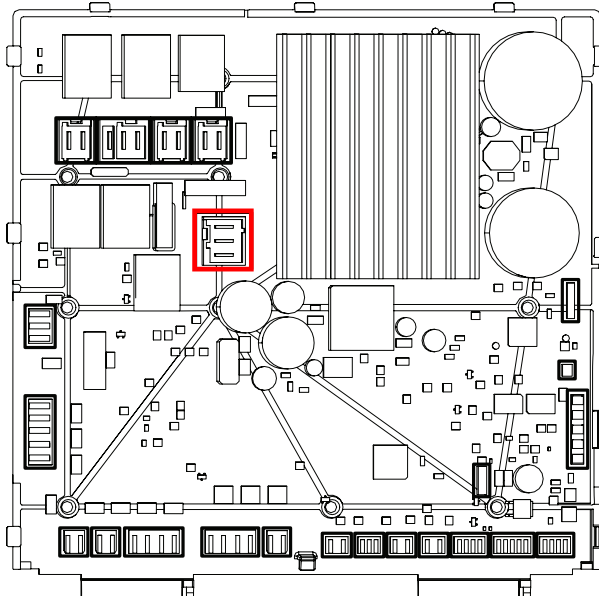

Figure 1 - Location of J6 on Appliance Control Unit (ACU)

7. Block the rotor by inserting a narrow shaft flat-blade screwdriver into the slot at the back of the rotor as illustrated in Figure 2. Align the tip of the screwdriver with the channel left-edge when loosening the rotor bolt and the right-edge when tightening. See Figure 2.

8. While the rotor is blocked, use a ratchet and a 5/8" hex head bit to loosen the rotor bolt as shown in Figure 2.

NOTE: The same procedure must be performed when reattaching the rotor during reinstallation.

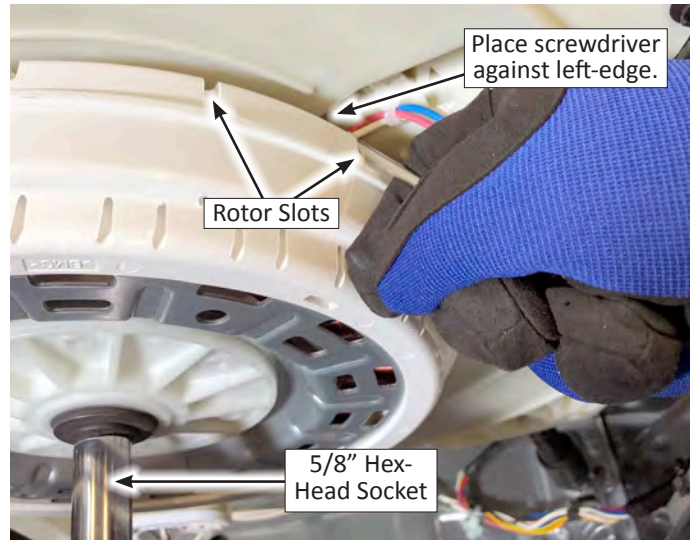

Figure 2

9. Remove the rotor from the stator by pulling it backwards.
10. Remove all motor harness clips (push mount wire ties) that may be securing the motor harness to the drum or ACU.
11. Use a T-30 Torx socket to remove the six (6) stator bolts as illustrated in Figure 3. Remove the stator assembly.



Figure 3

IMPORTANT: Be sure to protect the rotor and stator from dust or debris during disassembly and reassembly. Debris on the rotor or stator can damage the motor during operation.

Removing the Bulk Dispense Assembly (on some models)

⚠ WARNING



Electrical Shock Hazard
 Disconnect power before servicing.
 Replace all parts and panels before operating.
 Failure to do so can result in death or electrical shock.

To Remove the Bulk Dispense Assembly (on some models)

1. Unplug washer or disconnect power.
2. Turn off water supply to washer.
3. Disconnect hot and cold water inlet hoses and remove the drain hose from the standpipe or laundry tub.
4. Perform the procedures on page 4-2, "Removing the Top Panel" prior to performing the following steps.
5. Perform the procedures on page 4-17, "Removing the Front Panel" prior to performing the following steps.
6. Release the black hose from hose clip to the left of the drain pump filter.
7. Disconnect the following connectors from the top of the Metering Support Bracket (see Figure 1 below):
 - a. Blue Harness - Softener Level Sensor
 - b. Red Harness - Detergent Dosing Pump
 - c. Yellow Harness - Softener Dosing Pump
 - d. Black Harness - Detergent Level Sensor

8. Using a ¼" nut driver, remove the six (6) screws illustrated in Figure 2, securing the Metering Support Bracket to the cabinet.



Figure 2

9. Unclip the three (3) harness clips attached to the Metering Support Bracket (circled in Figure 1).
10. Using pliers, remove the hose clamps from the dosing-to-drain pump hoses as shown in Figure 3. Remove hoses and remove the Bulk Dispense Assembly.

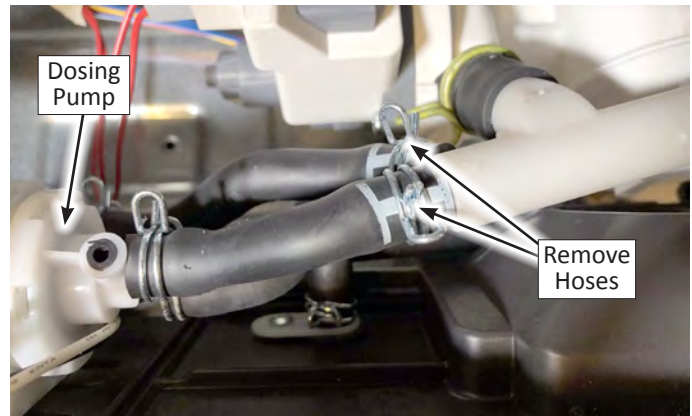

Figure 3

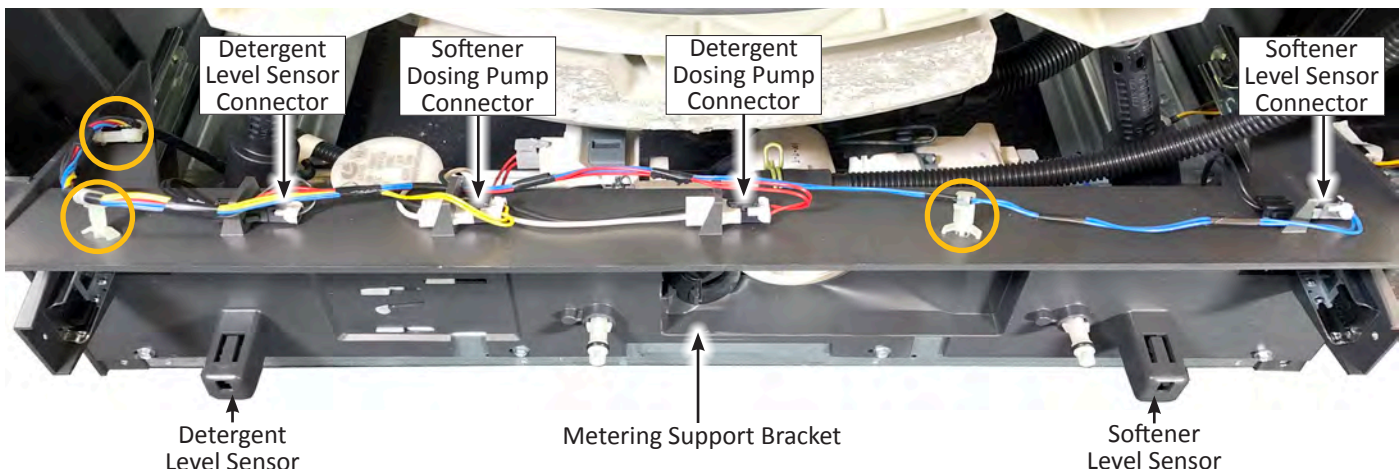

Figure 1 - Bulk Dispense Assembly

Removing the Bulk Dispense Assembly (on some models)

To Remove the Dosing Pumps

The Detergent and Fabric Softener Dosing Pumps are located on the back of the Metering Support Bracket as illustrated in Figure 4. They are both held in place by a slide and lock mechanism.

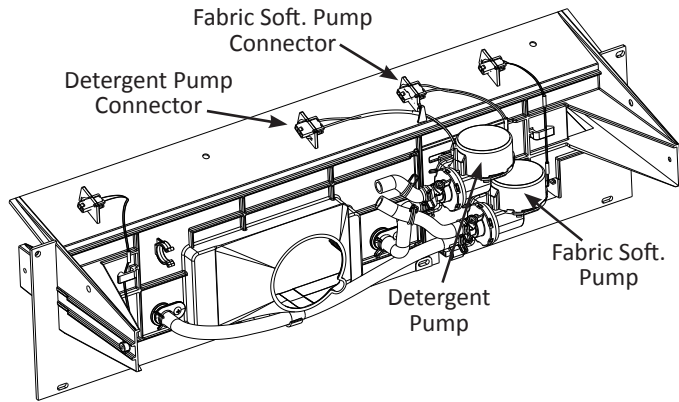

Figure 4 - Back of Metering Support Bracket

Perform the following procedures to remove the Dosing Pump(s):

1. To remove the Dosing Pump(s), use a small flat-blade screwdriver to pry up the locking tab and slide the pump to one direction to remove from bracket. See Figure 5.

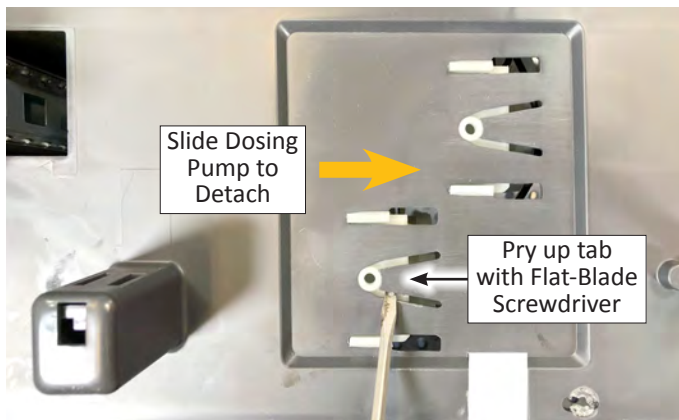

Figure 5

2. Reverse procedure to reinstall the dosing pump(s).

To Remove the Level Sensors

The Detergent and Fabric Softener Level Sensors are located at the bottom of the Metering Support Bracket as illustrated in Figure 6. They are both held in place by a slide and lock mechanism.

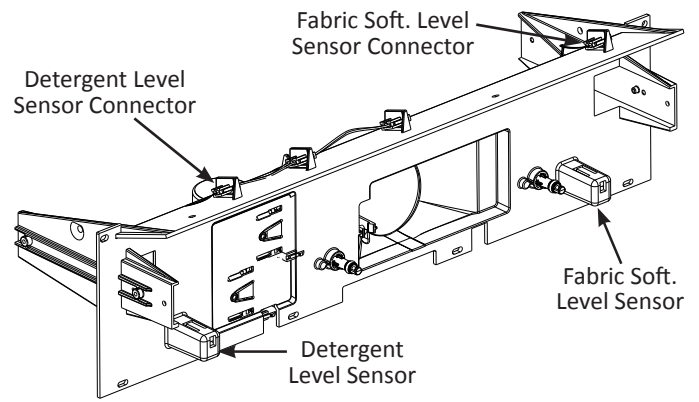

Figure 6 - Front of Metering Support Bracket

Perform the following procedures to remove the Level Sensor(s):

1. To remove the Level Sensor(s), use a small flat-blade screwdriver to pry up on the locking tab and slide sensor out of compartment. See Figure 7.

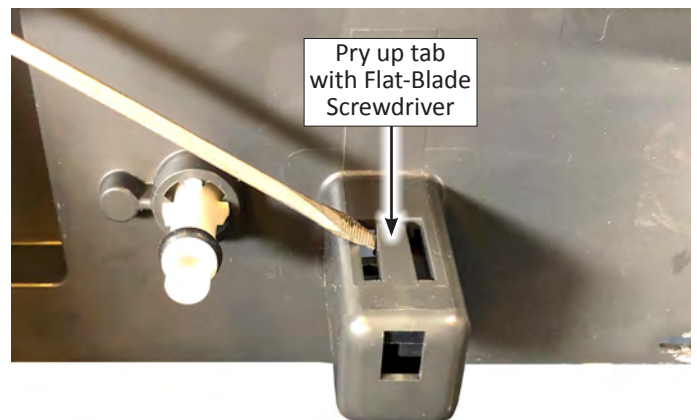

Figure 7

2. Reverse procedure to reinstall the level sensor(s).

Removing the Drain/Recirculation Pumps

⚠ WARNING



Electrical Shock Hazard
Disconnect power before servicing.
Replace all parts and panels before operating.
Failure to do so can result in death or electrical shock.

To Remove the Drain/Recirculation Pumps

1. Unplug washer or disconnect power.
2. Turn off water supply to washer.
3. Disconnect hot and cold water inlet hoses and remove the drain hose from the standpipe or laundry tub.
4. Perform the procedures on page 4-2, "Removing the Top Panel" prior to performing the following steps.
5. Perform the procedures on page 4-17, "Removing the Front Panel" prior to performing the following steps.
6. If the washer has a Bulk Dispenser Assembly, perform the procedures on page 4-20, "Removing the Bulk Dispense Assembly" prior to performing the following steps.
7. Place a broad, flat container beneath the drain pump filter to collect the drain water. Remove the plug from the black drain hose and empty the water from the drain pump into the container. Repeat this procedure if necessary until all the water has drained. Make sure that the black hose is completely dry and replace the plug.
8. Disconnect the blue Drain Pump connector and the red Recirculation Pump connector. See Figure 1.

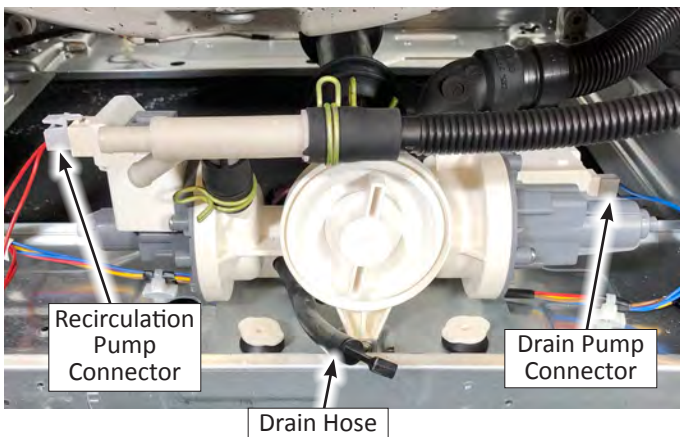

Figure 1

9. Slide off hose clamps and remove the recirculation pump hose, the drain hose, and the tub to pump hose (see Figure 2).

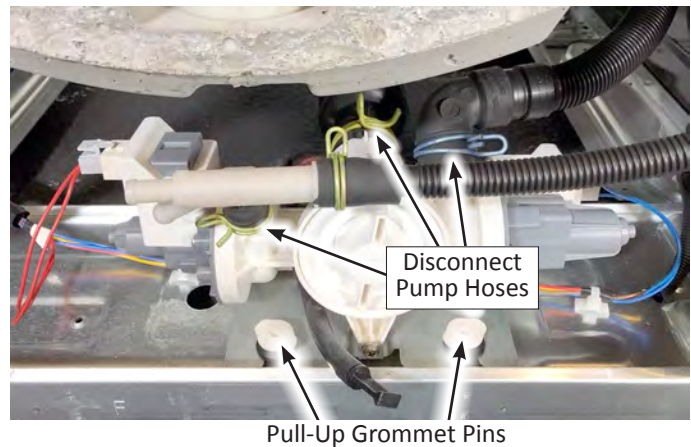

Figure 2

10. Pull up on the four (4) grommet pins to disengage pump from washer (see Figure 2). Remove the Drain/Recirculation Pump assembly.
11. Reverse procedure to reinstall Drain/Recirculation Pump.

Removing the Tub Assembly

WARNING



Electrical Shock Hazard

Disconnect power before servicing.

Replace all parts and panels before operating.

Failure to do so can result in death or electrical shock.

To Remove the Tub Assembly

1. Unplug washer or disconnect power.
2. Turn off water supply to washer.
3. Disconnect hot and cold water inlet hoses and remove the drain hose from the standpipe or laundry tub.
4. Perform the procedures on page 4-2, "Removing the Top Panel" prior to performing the following steps.
5. Perform the procedures on page 4-3, "Removing the Rear Panel" prior to performing the following steps.
6. Perform the procedure on page 4-4, "Removing the Water Level Switch" prior to performing the following steps.
7. If exists, perform the procedures on page 4-6, "Removing the Drum Light" prior to performing the following steps.
8. Perform the procedures on page 4-8, "Removing the Water Inlet Valves" prior to performing the following steps.
9. Perform the procedures on page 4-9, "Removing the Appliance Control Unit" prior to performing the following steps.
10. Perform the procedures on page 4-10, "Removing the Top Rear Bracket" prior to performing the following steps.
11. Perform the procedures on page 4-11, "Removing the Wash Heater/Thermistor Assembly" prior to performing the following steps.
12. If exists, perform the procedures on page 4-12, "Removing the Dryer Heating Channel Assembly" prior to performing the following steps.
13. If exists, perform the procedure on page 4-13, "Removing the Condenser Duct Assembly" prior to performing the following steps.
14. Perform the procedure on page 4-17, "Removing the Front Panel" prior to performing the following steps.
15. Perform the procedure on page 4-18, "Removing the Single Dose Dispenser Assembly" prior to performing the following steps.
16. Perform the procedure on page 4-19, "Removing the Direct Drive Motor" prior to performing the following steps.
17. If exists, perform the procedure on page 4-20, "Removing the Bulk Dispense Assembly" prior to performing the following steps.
18. Using either a ¼" hex-head, or T20 Torx driver, remove the top-front water channel and console bracket.
19. Use a ratchet and a Torx 50 bit to remove the three (3) screws securing the top counter weight to the top of the tub assembly. Remove counter weight and set aside for reassembly.
20. Use a ratchet and a Torx 50 bit to remove the three (3) screws securing the bottom counter weight to the bottom of the tub assembly. Remove counter weight and set aside for reassembly.
21. Press the tab on one side of the dampers (closest to the tub) and then twist the damper 1/4 turn to disengage from the tub, then pull damper away from tub assembly. Repeat for all dampers.
22. Disconnect all hoses connected to the tub assembly.
23. Remove any harnesses that are secured or wire-tied to the tub assembly.
24. Using either a ¼" hex-head, or T20 Torx driver, remove the four (4) screws securing the Top Brace to the right and left side panels. Use this top brace to lift up tub assembly and remove tub from the washer.
23. Reverse procedure to reinstall the tub assembly.

Notes

Section 5: Connectivity

This section provides connectivity setup, download, installation, and troubleshooting for the “Whirlpool & Maytag Front-Load Washers.”

- Internet Connectivity Guide
- Connectivity Troubleshooting

Internet Connectivity Guide

Get the App and Get Connected

With your mobile device, get the app, connectivity setup instructions, terms of use, and privacy policy at:
www.whirlpool.com/connect

In Canada, visit

www.whirlpool.ca/connect

and click on the Whirlpool® Connected Appliances link.

INITIAL SET UP

IMPORTANT: Proper installation of the appliance prior to use is the customer responsibility. Be sure to read and follow the Installation Instructions that came with the appliance.

Connectivity requires WiFi and account creation. App features and functionality subject to change. Data rates may apply. If you have any problems or questions, call Whirlpool Corporation Connected Appliances at **1-866-333-4591**.

You Will Need:

- A home wireless router supporting:
 - Frequency Band: **2.4GHz** Band IEEE 802.11 b/g/n
 - Security: WiFi Protected Access **WPA2**
 - Network Support: **IPv4** Minimum

If you are unsure of the router's capabilities, refer to the router manufacturer's instructions.

- The router to be ON and have a live internet connection.
- The 10-character Smart Appliance ID (SAID) code for your appliance. The SAID code is either printed on a label on the appliance or can be found on the LCD screen. Refer to the appliance Use & Care Guide for the location.

Download and Install with Touch Screen

Perform the following steps to download and install the App. Once installed, launch the app. You will be guided through the steps to set up a user account and to connect the appliance. If you have any problems or questions, call Whirlpool Corporation Connected Appliances at **1-866-333-4591**.

1. Download the Mobile App.

From your mobile device, smartphone, or tablet, go to www.whirlpool.com/connect or www.whirlpool.ca/connect and follow the instructions to download and install the Whirlpool® app.



2. Create Your Own Account.
3. Select Add Appliance on the Mobile Application.
4. Scan the QR code from the Appliance WiFi settings touchscreen display.
5. Follow Mobile Application instructions to use the Appliance touchscreen to select your home router and enter your home router passphrase on the appliance touch screen.
6. Select next on the Mobile Application instruction Screen.
7. On the Mobile application observe and wait for the Appliance to indicate that it is connected to the home router, Internet, and Cloud Service.
8. Upon Success name your appliance and start using its remote features.

Download and Install with non-Touch Screen

Perform the following steps to download and install the App. Once installed, launch the app. You will be guided through the steps to set up a user account and to connect the appliance. If you have any problems or questions, call Whirlpool Corporation Connected Appliances at **1-866-333-4591**.

1. Download the Mobile App.

From your mobile device, smartphone, or tablet, go to www.whirlpool.com/connect or www.whirlpool.ca/connect and follow the instructions to download and install the Whirlpool® app.
2. Create Your Own Account.
3. Select Add Appliance on the Mobile Application.
4. Scan the QR code from the Appliance Label or manually enter the SAID and MAC.
5. On the Mobile Application enter your home router passphrase (if your home router has a choice of frequency bands - be sure to use the 2.4GHz band router name).
6. Select next on the Mobile Application instruction Screen.
7. On the Mobile application observe and wait for the Appliance to indicate that it is connected to the home router, Internet, and Cloud Service.
8. Upon Success name your appliance and start using its remote features.

NOTES:

- Once the washer is connected to the consumer's home WiFi network, it will remain linked even if the power goes out, the appliance is moved, or if it is put in storage for a while.
- If the consumer replaces their wireless router (or get a different Smart Washer), you will need to repeat this connectivity setup process.

Connectivity Troubleshooting

Troubleshooting Guide

| Connection Status | Console Indicator Lights |
|---|--|
| Washer is not connected | <ul style="list-style-type: none"> Smart Grid (Connected) status indicator is OFF |
| Washer is attempting to connect to home WiFi router | <ul style="list-style-type: none"> Smart Grid (Connected) status indicator is blinking slowly |
| Washer is connected to home WiFi router, but Whirlpool™ app or Smart Grid functions do not work | <ul style="list-style-type: none"> Smart Grid (Connected) status indicator is blinking |
| Washer is connected to home WiFi router, and the Whirlpool™ app works | <ul style="list-style-type: none"> Smart Grid (Connected) status indicator is ON |

| If you experience | Possible Causes | Solution |
|---|---|---|
| Washer is not connected to home WiFi router: | The washer may be in standby mode. | Touch the POWER/CANCEL button on the washer. |
| | The washer has never been connected to the home WiFi router. | See “Connectivity Guide” in this section, pages 5-2. |
| | Lost connection to home WiFi router. | Check whether the router is on and working with other computers or devices in the home (able to access the Internet). |
| | Weak signal strength or signal interference between the washer and router. | Try to place the wireless router closer to the washer. It may be necessary to install a WiFi range extender. |
| Washer is connected to home WiFi router, but Whirlpool® app or Smart Grid functions do not work | User account has not been properly set up, or the washer has not been registered in an account. | See “Connectivity Guide” in this section or the Whirlpool™ app directly for account setup and washer registration instructions. |
| | | Verify that the washer is paired with the customer account in the app. |
| | | Verify correct e-mail address, mobile number, and notification preferences. |

Notes

PRODUCT SPECIFICATIONS & WARRANTY INFORMATION SOURCES

IN THE UNITED STATES:

**FOR PRODUCT SPECIFICATIONS AND WARRANTY INFORMATION CALL:
FOR WHIRLPOOL PRODUCTS: 1-800-253-1301**

**FOR TECHNICAL ASSISTANCE WHILE AT THE CUSTOMER'S HOME CALL:
THE TECHNICAL ASSISTANCE LINE: 1-800-832-7174**

**HAVE YOUR STORE NUMBER READY TO IDENTIFY YOU AS AN
AUTHORIZED IN-HOME SERVICE PROFESSIONAL**

**FOR LITERATURE ORDERS (CUSTOMER EXPERIENCE CENTER):
PHONE: 1-800-851-4605**

**FOR TECHNICAL INFORMATION AND SERVICE POINTERS:
www.servicematters.com**

IN CANADA:

**FOR PRODUCT SPECIFICATIONS AND WARRANTY INFORMATION CALL
PHONE: 1-800-461-5681**

**FOR TECHNICAL ASSISTANCE WHILE AT THE CUSTOMER'S HOME CALL:
THE TECHNICAL ASSISTANCE LINE: 1-800-488-4791**

**HAVE YOUR STORE NUMBER READY TO IDENTIFY YOU AS AN
AUTHORIZED IN-HOME SERVICE PROFESSIONAL**

**Whirlpool & Maytag
Front-Load Washers**

W11169652A