

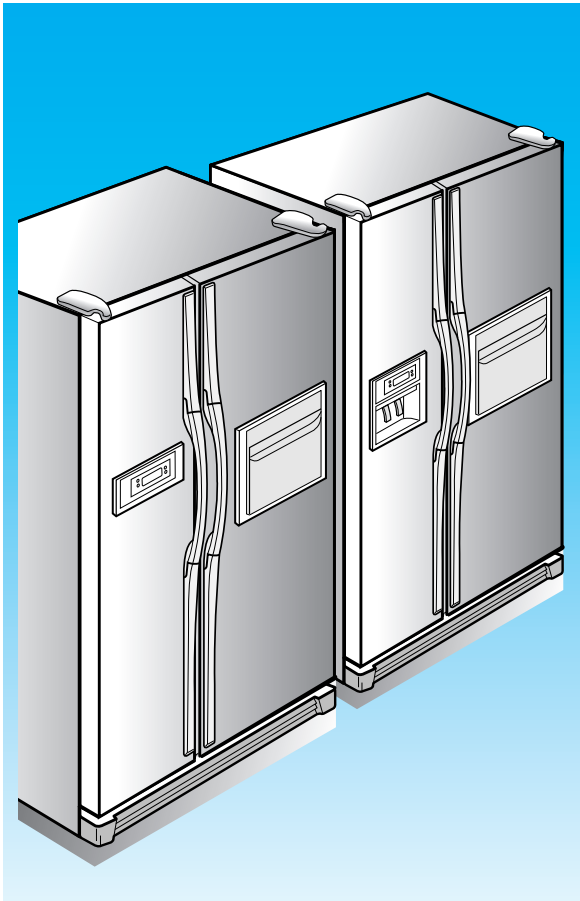

**Model : SR-S2026C(D) SR-S2226C(D)
SR-S2027C(D) SR-S2227C(D)
SR-S2028C(D) SR-S2228C(D)
SR-S2029C(D) SR-S2229C(D)
SR-S2025C(D)
SR-S20NTC(D) SR-S22NTC(D)
SR-S20BTC(D) SR-S22BTC(D)
SR-S20DTC(D) SR-S22DTC(D)
SR-S20FTC(D) SR-S22FTC(D)
SR-S20YTC(D)**

***SERVICE* Manual**

REFRIGERATOR



Contents

1. Product Specification	2
2. Safety Warning & Caution	3
3. Specification of Electric Components	5
4. Circuit Diagram	7
5. Dimension & Part Name of Refrigerator	9
6. Freezing Cycle & Cold Air Circulation Course in Refrigerator	15
7. Function & Operating Instruction of Refrigerator	17
8. Operating Principle of Circuit	26
9. Trouble Checkup & Repair Method	34
10. Operation Principle & Repair Method of ICE-MAKER.....	50
11. Reference	55
12. Disassembly Method of Freezer & Refrigerator	60
13. Method of Hinge up Assembly & Disassembly	63
14. Refrigerator Exploded view & List	64
15. Machine Room Assembly Specification	89
16. Disassembly & Assembly Method of Internal Part of Electric Field Box	90
17. Installation Method of Water Supply Tube	91
18. Installation of the Water Dispenser Line	92
19. PCB Circuit Diagram and Service Components List	93
20. Specification of Principal Part of Circuit	94

1. Product Specifications

Item		Specification				
Model		SR-S2026C(D) SR-S20NTC(D) Basic	SR-S2025C(D) SR-S20YTC(D) Water Dispenser	SR-S2027C(D) SR-S20BTC(D) Basic & H/B	SR-S2028C(D) SR-S20DTC(D) Dispenser	SR-S2029C(D) SR-S20FTC(D) Dispenser & H/B
Net Capacity	Total	562ℓ	547ℓ	540ℓ		
	Refrigerator	349ℓ	336ℓ	349ℓ		
	Freezer	213ℓ	211ℓ	191ℓ		
Net dimension(W×H×D)		908mm x 719(724)mm x 1760mm				
Rated Frequency and Frequency		230~240V/50Hz				
Motor Rated Consumption Power		155W			160W	
Electric Heater Rated Consumption Power		400W	410W	412W	412W	422W
Kind of Refrigerator		Indirect Cooling Method Refrigerator				
Refrigerant		HFC-134a				
Refrigerant Input Amount		190gr				
Freezer Performance		* * * * (4-STAR)				
Product Weight		111Kg		111Kg	117Kg	117Kg

Item		Specification			
Model Name		SR-S2226C(D) SR-S22NTC(D) Basic	SR-S2227C(D) SR-S22BTC(D) Basic & H/B	SR-S2228C(D) SR-S22DTC(D) Dispenser	SR-S2229C(D) SR-S22FTC(D) Dispenser & H/B
Net Inside Capacity	Total Inside Capacity	599ℓ		569ℓ	
	Freezer	227ℓ		197ℓ	
	Refrigerator	372ℓ		372ℓ	
Outer Size (width X depth X height)		908mm x 754(759)mm x 1760mm			
Rated Frequency and Frequency		230~240V/50Hz			
Motor Rated Consumption Power		155W		160W	
Electric Heater Rated Consumption Power		400W	410W	412W	422W
Kind of Refrigerator		Indirect Cooling Method Refrigerator			
Refrigerant		HFC-134a			
Refrigerant Input Amount		190gr			
Freezer Performance		* * * * (4-STAR)			
Product Weight		121Kg	121Kg	127Kg	127Kg

2. SAFETY WARNINGS

Read all instructions before using this product and keep to the instructions in order to prevent danger or property damage.

CAUTION/WARNING SYMBOLS DISPLAYED SYMBOLS

 <p>Warning</p> <p>Indicates that a danger of death or serious injury exists.</p>	 <p>means "Prohibition".</p>
 <p>Caution</p> <p>Indicates that a risk of personal injury or material damage exists.</p>	 <p>means "Do not disassemble".</p>
	 <p>means "No contact".</p>
	 <p>means "The things to be followed".</p>
	 <p>means "Power cord should be unplugged from the consent".</p>
	 <p>means "Earth to prevent Electric shock".</p>



Warning & Caution

Pull the power plug out to exchange the interior lamp of the refrigerator.

- It may cause electric shock.



Unplug

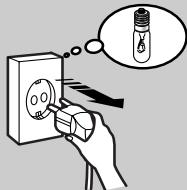

Use the rated components on the replacement.

- Check the correct model, rated voltage, rated current, operating temperature and so on.



Rated components

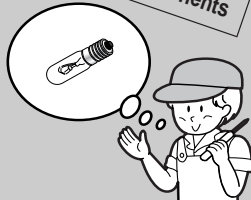

On repair, make sure that the wires such as harness are bundled tightly.

- Bundle tightly wires in order not to be detached by the external force and then not to be wetted.

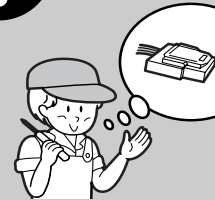

On repair, remove completely dust or other things of housing parts, harness parts, and check parts.

- Cleaning may prevent the possible fire by tracking or short.

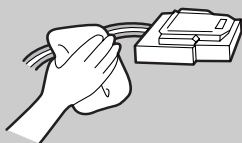

After repair, check the assembled state of components.

- It must be in the same assembled state when compared with the state before disassembly.

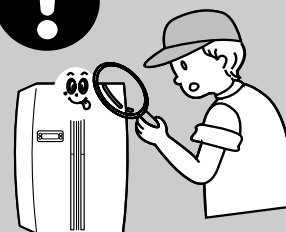

Check if there is any trace indicating the permeation of water.

- If there is that kind of trace, change the related components or do the necessary treatment such as taping using the insulating tape.

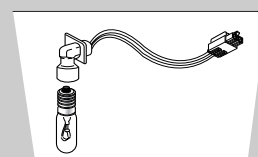

* Place let users know in detail.



Warning & Caution

Do not allow users to put bottles or kinds of glass in the freezer.

- Freezing of the contents may inflict a wound.



Prohibition

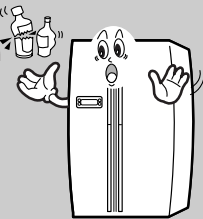

Do not allow users to store narrow and lengthy bottles or foods in a small multi-purpose room.

- It may hurt users when refrigerator door is opened and closed resulting in falling stuff down.



Prohibition



Do not allow users to store pharmaceutical products, scientific materials, etc., in the refrigerator.

- The products which temperature control should not be stored in the refrigerator.



Prohibition



Do not allow users to insert the power plugs for many products at the same time.

- May cause abnormal generation of heat or fire.



Prohibition

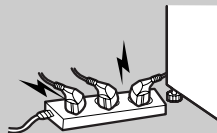

Do not allow users to disassemble, repair or alter.

- It may cause fire or abnormal operation which leads to injury.



Do not disassemble

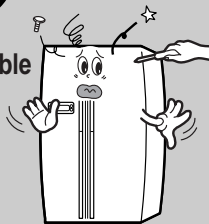

Do not allow users to bend the power cord with excessive force or do not have the power cord pressed by heavy article.

- May cause fire.

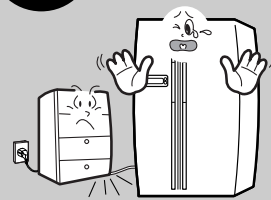

Do not allow users to store articles on the product.

- Opening or closing the door may cause things to fall down, with may inflict a wound.



Prohibition

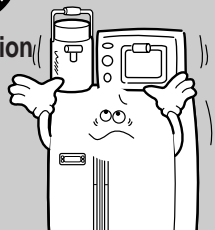

Do not allow users to install the refrigerator in the wet place or the place which water splashes.

- Deterioration of insulation of electric parts may cause electric shock or fire.

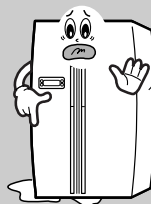

Make sure of the earth.

- If earthing is not done, it will cause breakdown and electric shock.



Earth

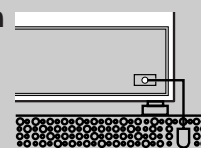

3. Specifications of Electric Components

Items			Specification			
Models			SR-S20..~SR-S22..			
Freezing Capacity			* * * * (4 STAR)			
Components for Freezer	Compressor	Model	DK182Q-L2U			
		Starting type	R.S.C.R			
		Oil Charge	FREOL α - 15 (ESTER)			
	Evaporator	Freezer	SPLIT FIN TYPE			
		Refrigerator	SPLIT FIN TYPE			
	Condenser		Forced and natural convection type			
	Dryer		Molecular sieve XH-9			
	Capillary tube		0.82 × 3000, 5.5 Kg/cm ²			
Refrigerant		HFC-134a				
Room Temperature Sensor Components	Freezer	Model	Temperature Selection	ON(°C)	OFF(°C)	
		THERMISTOR (F-SENSOR) 502AT	-26°C	-25.0	-27.0	
			-20°C	-19.0	-21.0	
	-14°C		-13.0	-15.0		
	Refrigerator	Model	Temperature Selection	ON(°C)	OFF(°C)	
		THERMISTOR (R-SENSOR) 502AT	-1°C	0.0	-2.0	
3°C			4.0	2.0		
7°C	8.0		6.0			
Defrost Related Components	Defrost Cycle	First Defrost Cycle (Concurrent defrost of F and R)		4 hr ± 10 min		
		Defrost Cycle(FRE)		12 ~ 24 hr (vary according to the conditions used)		
		Defrost Cycle(REF)		6 ~ 12 hr (vary according to the conditions used)		
		Pause time		10 ± 2 min		
	Defrost Sensor	F Defrost-Sensor	Model	THERMISTOR (502AT)		
			SPEC	5.0 k Ω at 25°C		
		R Defrost-Sensor	Model	THERMISTOR (502AT)		
			SPEC	5.0 k Ω at 25°C		
	Thermal-Fuse		Rated	AC 250V 10A		
Operating temperature			77 ± 4°C			

Items			Specifications				
Model			SR-S2026, S2226 SR-S20NTC, S22NTC	SR-S20VTC, SR-S2025	SR-S2027, S2227 SR-S20BTC, S22BTC	SR-S2028, S2228 SR-S20DTC, S22DTC	SR-S2029, S2229 SR-S20FTC, S22FTC
Electric Components	Defrost-Heater(FRE)	Conducting at F Defrosting	230 W		230 W		
	Defrost-Heater(REF)	Conducting at R Defrosting	110 W		110 W		
	DRAIN Heater(FRE)	Conducting at F Defrosting	41 W		41 W		
	DRAIN Heater(REF)	Conducting at R Defrosting	25 W		25 W		
	DISPENSER Heater	Interlock with F-FAN	-		-	5W	5W
	HOME-BAR Heater	Interlock with COMP	-		10W	-	10W
	Thermal-Fuse for preventing overheating of Freezer Defrost-Heater		AC 250V 10A 72±4°C				
	Thermal-Fuse for preventing overheating of Refrigerator Defrost-Heater						
	Compressor		DK182Q-L2U				
	Condenser for COMP (Package type)	Running	350VAC-5μF				
		Starting	-				
	Starting-Relay	Model	J531Q35E330M385-2				
		Operation	33 Ω ±20%				
	Over-load Relay	Model	4TM265RFBYY-53				
		Temp. ON	130 ±5°C				
		Temp. OFF	69 ±9°C				
	Rated Voltage		230V/50,60Hz				
	MOTOR-BLDC(FRE)		240V/50Hz UDQMOO2H4ASS				
	MOTOR-BLDC(REF)		240V/50Hz UDQMOO2H4ASS				
	MOTOR-BLDC (Circuit)		240V/50Hz UDQMOO2H4ASS				
	Lamp(FRE)		AC240V/25W				
	Lamp(REF)		AC240V/25W × 2				
	Door Switch		AC250V 0.5A × 2				
Door Switch (HOME-BAR)		AC250V 0.5A					
Dispenser Switch		DECO 250VAC 6A					
Power cord		AC250V 12A					
Earth Screw		BSBN (BRASS SCREW)					

4. Circuit Diagram

For Basic & With Home Bar Models (SR-S2025, S20YTC, S2026, S2027, S2226, S2227/S20NTC, S20BTC, S22NTC, S22BTC)

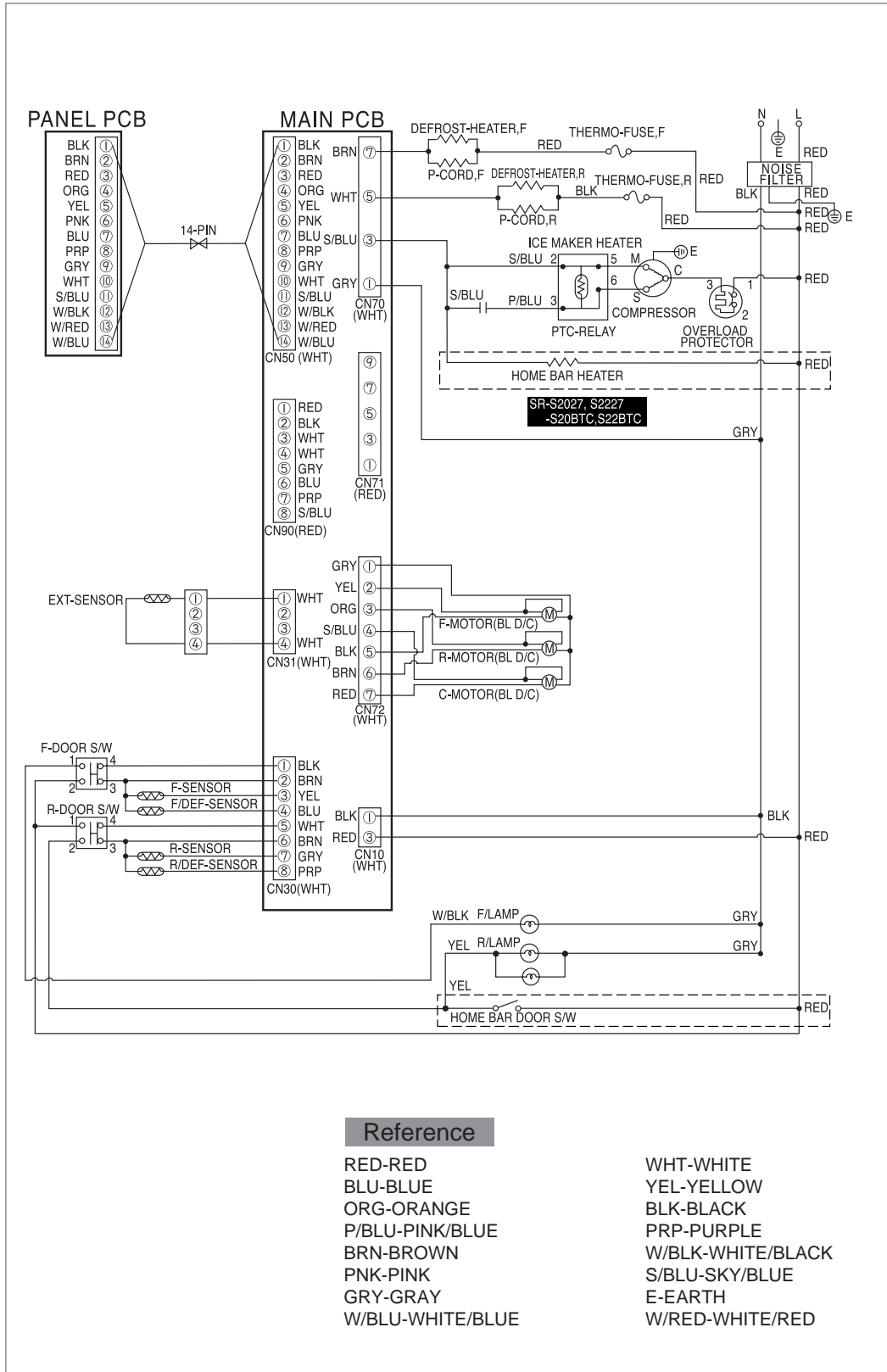

For Dispenser & With Home Bar Models (SR-S2028, S2029 S2228, S2229/S20DTC, S20FTC,S22DTC,S22FTC)

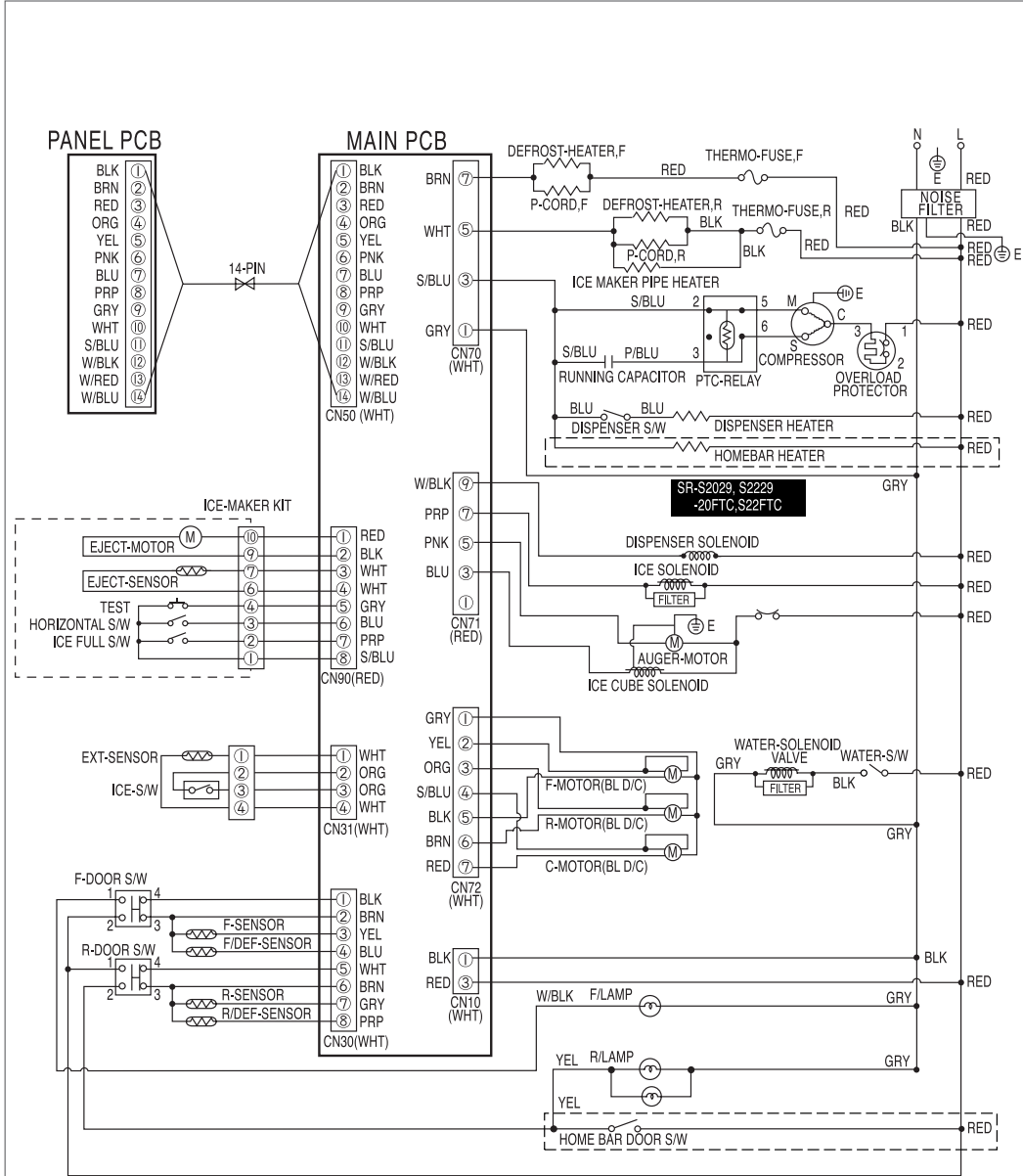

Reference

RED-RED	WHT-WHITE
BLU-BLUE	YEL-YELLOW
ORG-ORANGE	BLK-BLACK
P/BLU-PINK/BLUE	PRP-PURPLE
BRN-BROWN	W/BLK-WHITE/BLACK
PNK-PINK	S/BLU-SKY/BLUE
GRY-GRAY	E-EARTH
W/BLU-WHITE/BLUE	W/RED-WHITE/RED

5. Dimension & part name of refrigerator

5-1) Product Dimension (SR-S2025, S2-YTC)

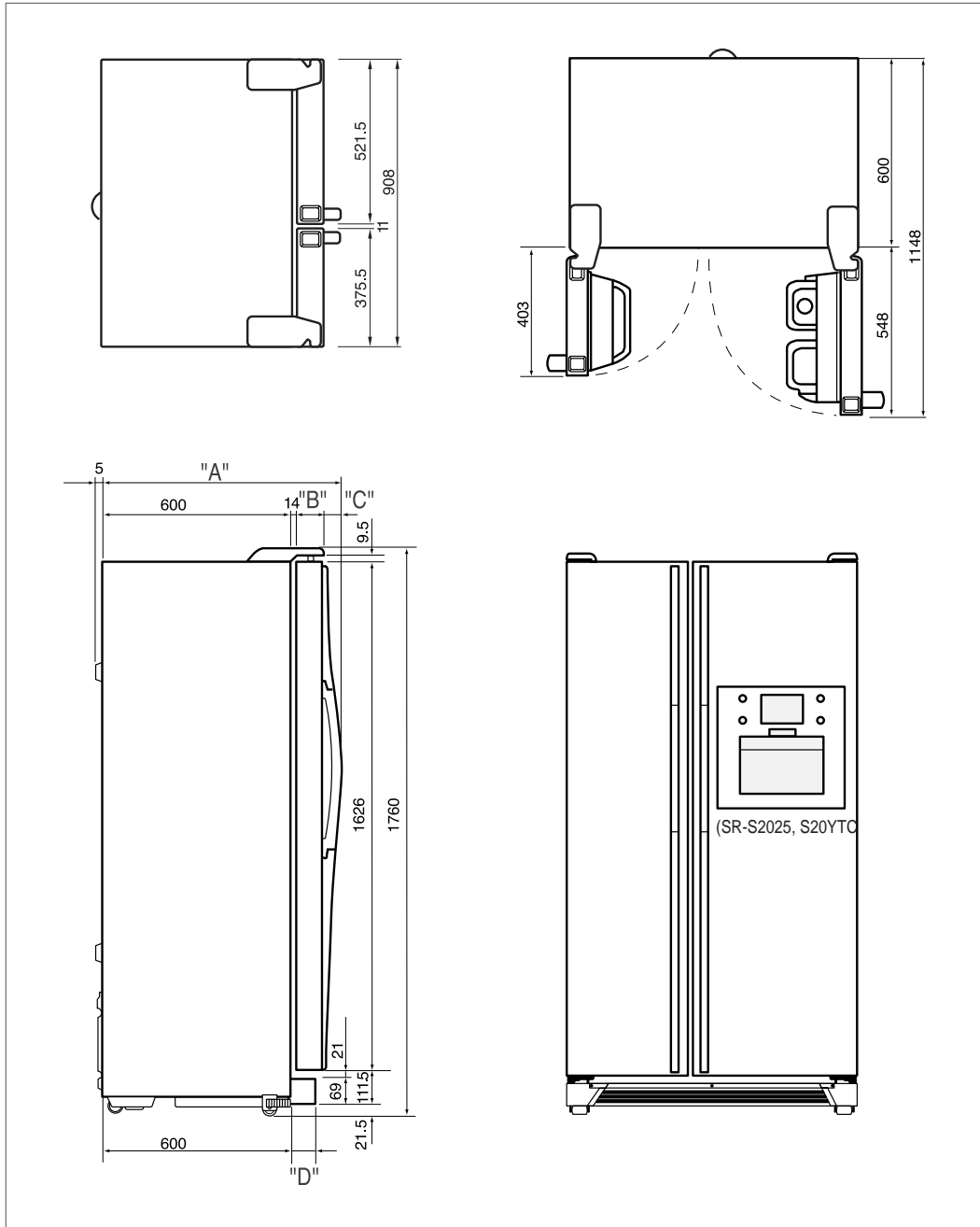

MODEL	"A"	"B"	"C"	"D"
SR-S2025C, S20YTC	719	50	55	54
SR-S2025D, S20YTC	714	50	50	54

5-2) Product Dimension (SR-S2026, S2027, S2226, S2227/S20NTC, S20BTC, S22NTC, S22BTC)

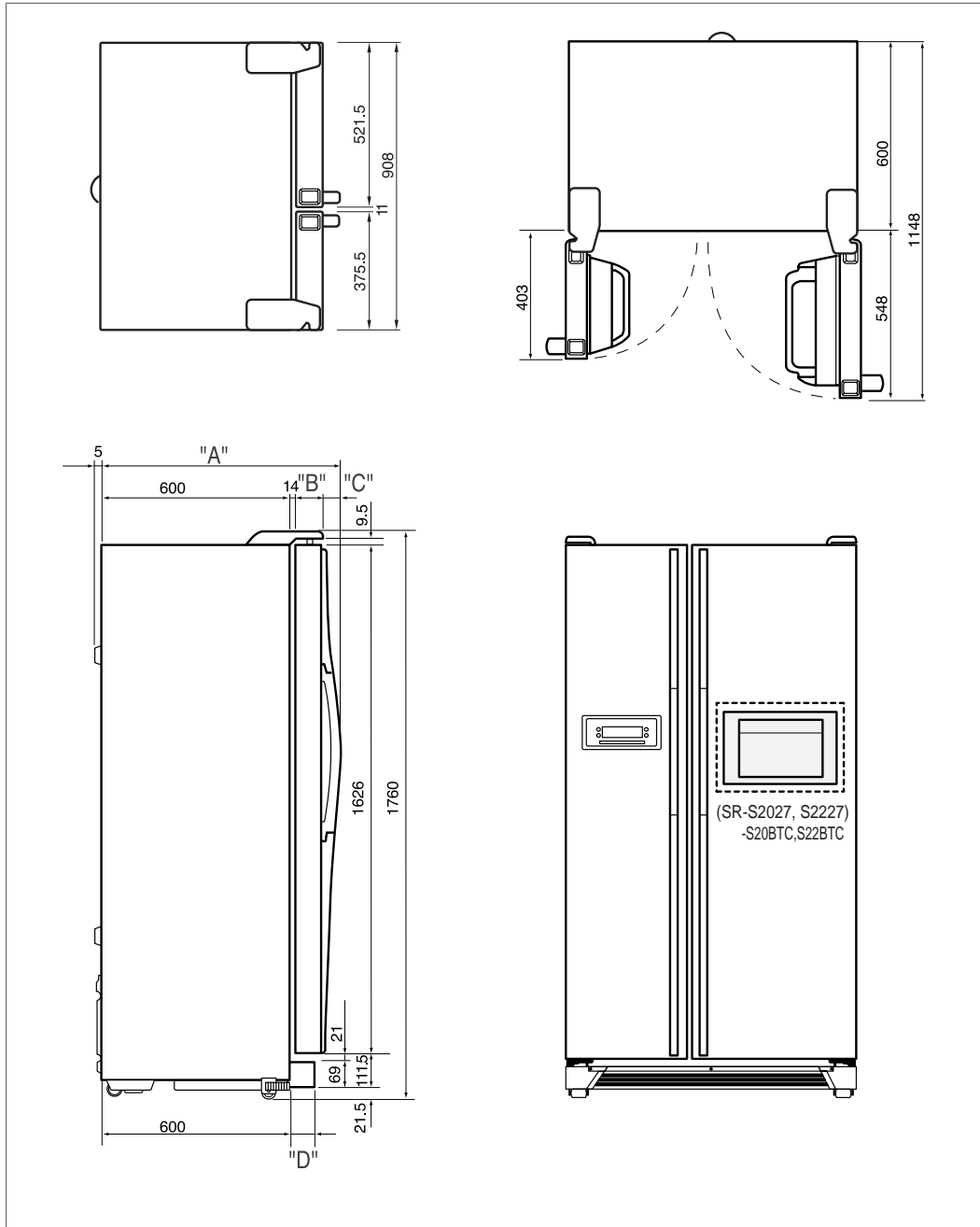

MODEL	"A"	"B"	"C"	"D"
SR-S2026C, S2027C/S20NTC, S20BTC(D)	719	50	55	54
SR-S2026D, S2027D/S20NTC(D), S20BTC(D)	714	50	50	54
SR-S2226C, S2227C/S22NTC, S22BTC(D)	754	85	55	89
SR-S2226D, S2227D/S22NTC(D), S22BTC(D)	749	85	50	89

5-3) Product Dimension (SR-S2028, S2029, S2228, S2229/S20DTC,S20FTC,S22DTC,S22FTC)

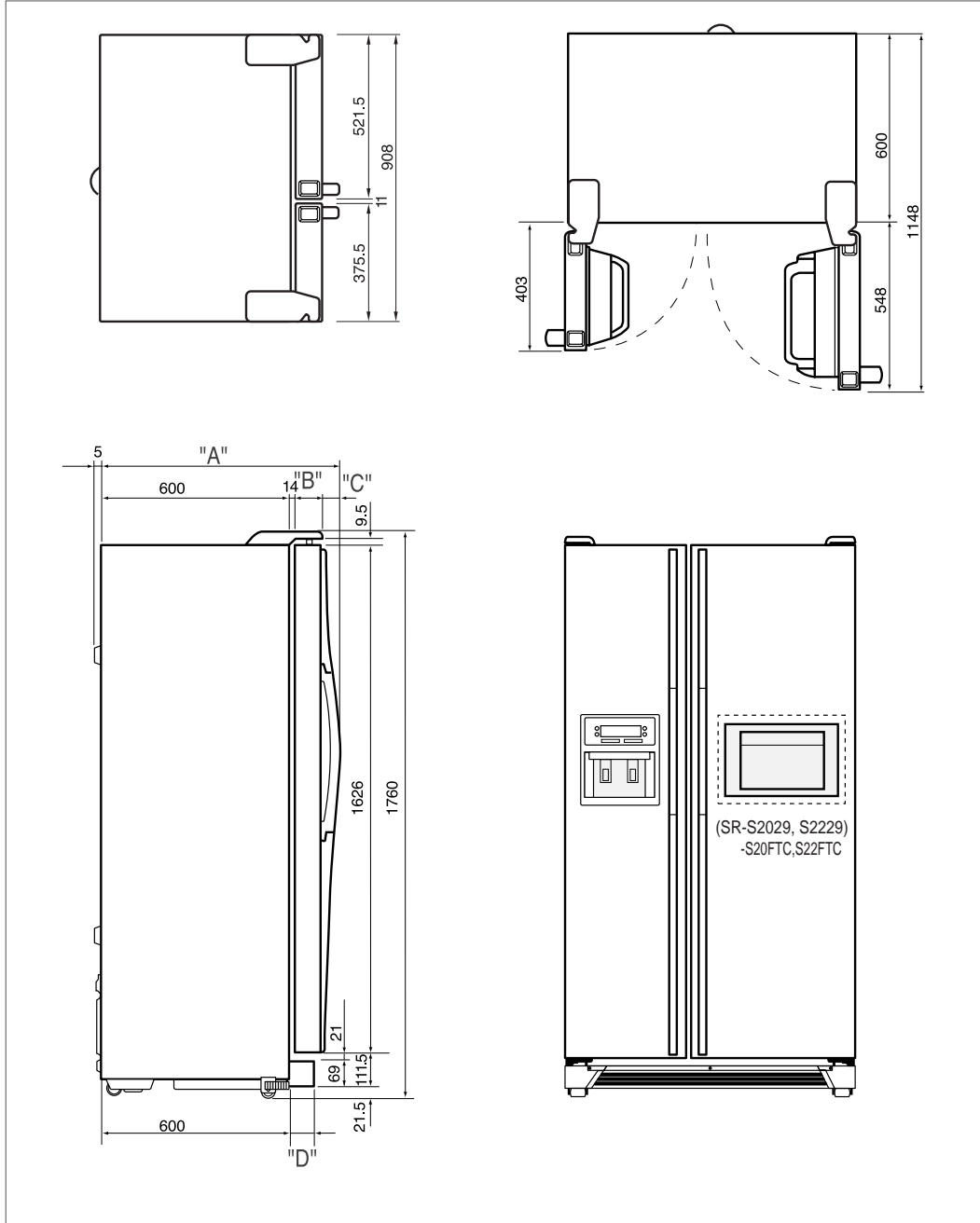

MODEL	"A"	"B"	"C"	"D"
SR-S2028C, S2029C/S20DTC,S20FTC(D)	719	50	55	54
SR-S2028D, S2029D/S20DTC(D),S20FTC(D)	714	50	50	54
SR-S2228C, S2229C/S22DTC,S22FTC(D)	754	85	55	89
SR-S2228D, S2229D/S22DTC(D),S22FTC(D)	749	85	50	89

5-4) Part Name (SR-S2025 / SR-S20YTC)

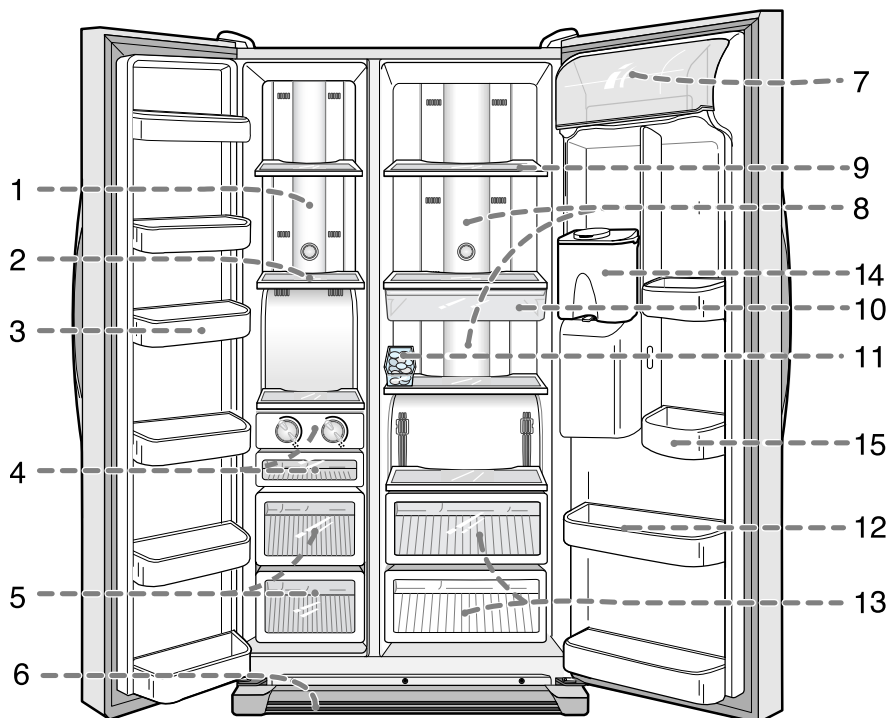

FREEZER

REFRIGERATOR

- | | |
|---------------------|---------------------|
| ① LAMP-INCANDESCENT | ⑦ COVER-GUARD |
| ② SHELF | ⑧ LAMP-INCANDESCENT |
| ③ GUARD | ⑨ SHELF |
| ④ TRAY-ICE & ICE | ⑩ TRAY-CHILLED ROOM |
| ⑤ CASE-BASKET | ⑪ TRAY-EGG |
| ⑥ COVER-LEG, FRONT | ⑫ GUARD |
| | ⑬ CASE-VEGETABLE |
| | ⑭ TANK-WATER ASS'Y |
| | ⑮ GUARD-VARIETY |

5-5) Part Name (SR-S2026, S2226/S20NTC,S22NTC)

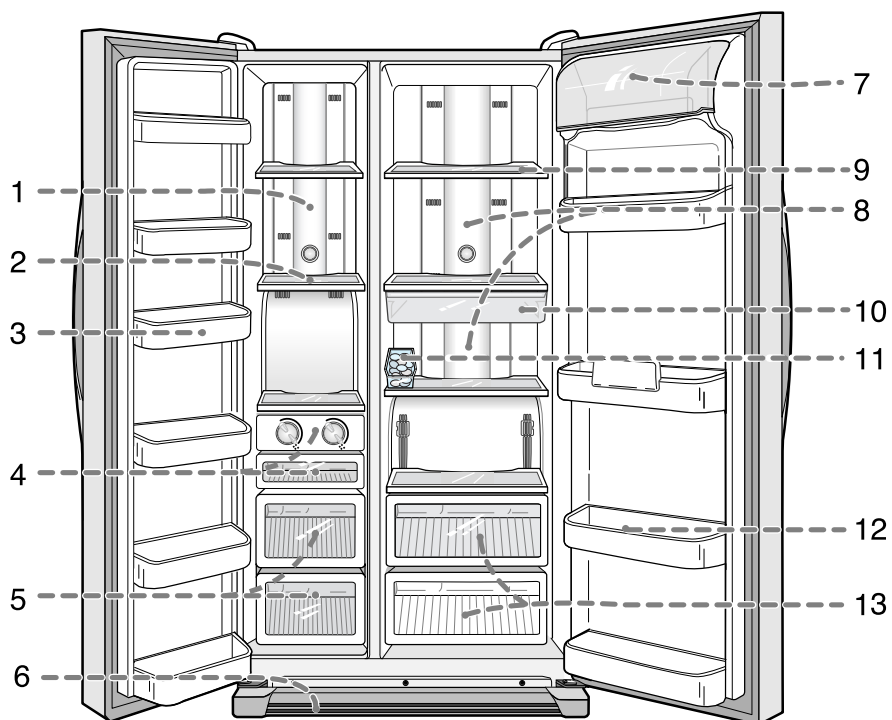

FREEZER

REFRIGERATOR

- | | |
|---------------------|---------------------|
| ① LAMP-INCANDESCENT | ⑦ COVER-GUARD |
| ② SHELF | ⑧ LAMP-INCANDESCENT |
| ③ GUARD | ⑨ SHELF |
| ④ TRAY-ICE & ICE | ⑩ TRAY-CHILLED ROOM |
| ⑤ CASE-BASKET | ⑪ TRAY-EGG |
| ⑥ COVER-LEG, FRONT | ⑫ GUARD |
| | ⑬ CASE-VEGETABLE |

5-6) Part Name (SR-S2027, S2227/S20BTC,S22BTC)

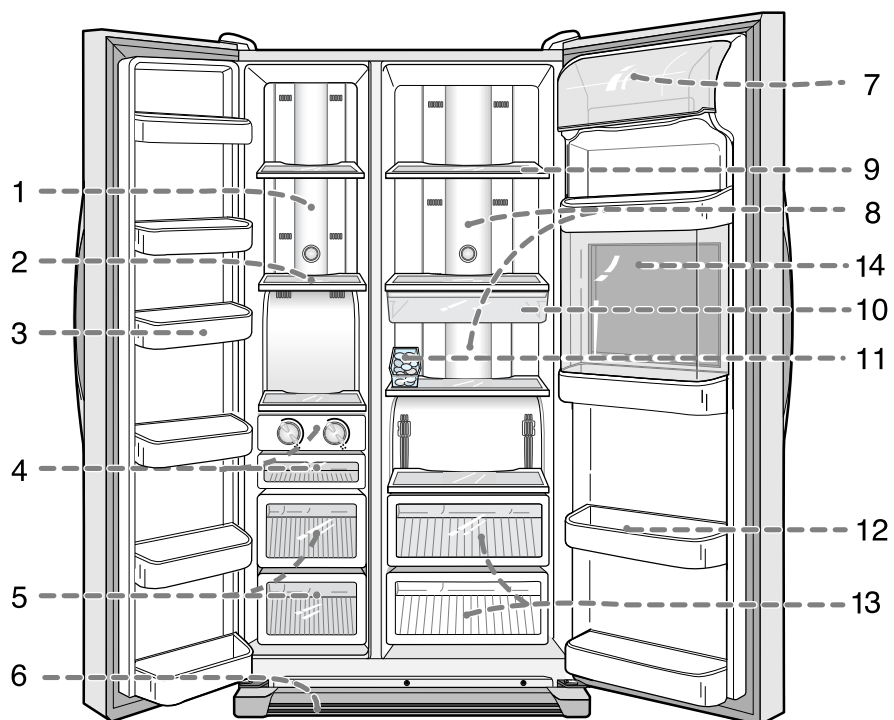

FREEZER

REFRIGERATOR

- | | |
|---------------------|---------------------|
| ① LAMP-INCANDESCENT | ⑦ COVER-GUARD |
| ② SHELF | ⑧ LAMP-INCANDESCENT |
| ③ GUARD | ⑨ SHELF |
| ④ TRAY-ICE & ICE | ⑩ TRAY-CHILLED ROOM |
| ⑤ CASE-BASKET | ⑪ TRAY-EGG |
| ⑥ COVER-LEG, FRONT | ⑫ GUARD |
| | ⑬ CASE-VEGETABLE |
| | ⑭ HOME-BAR |

5-7) Part Name (SR-S2028, S2228/S20DTC,S22DTC)

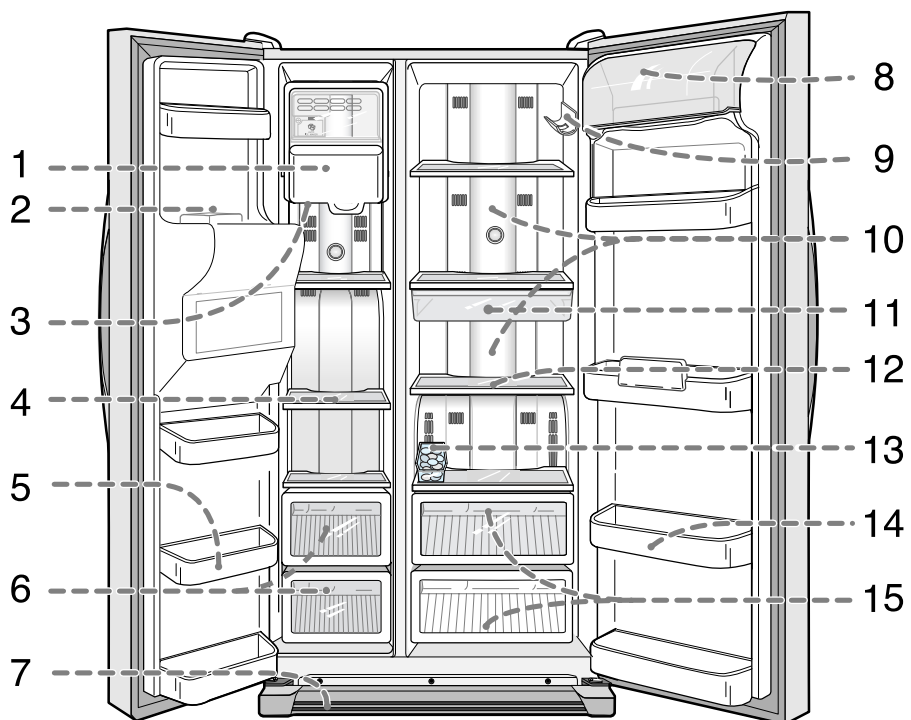

FREEZER

REFRIGERATOR

- | | |
|---------------------|---------------------|
| ① ICE-MAKER | ⑧ COVER-GUARD |
| ② ICE-CHUTE | ⑨ SHELF-WINE |
| ③ LAMP-INCANDESCENT | ⑩ LAMP-INCANDESCENT |
| ④ SHELF | ⑪ TRAY-CHILLED ROOM |
| ⑤ GUARD | ⑫ SHELF |
| ⑥ CASE-BASKET | ⑬ TRAY-EGG |
| ⑦ COVER-LEG, FRONT | ⑭ GUARD |
| | ⑮ CASE-VEGETABLE |

5-8) Part Name (SR-S2029, S2229/S20FTC,S22FTC)

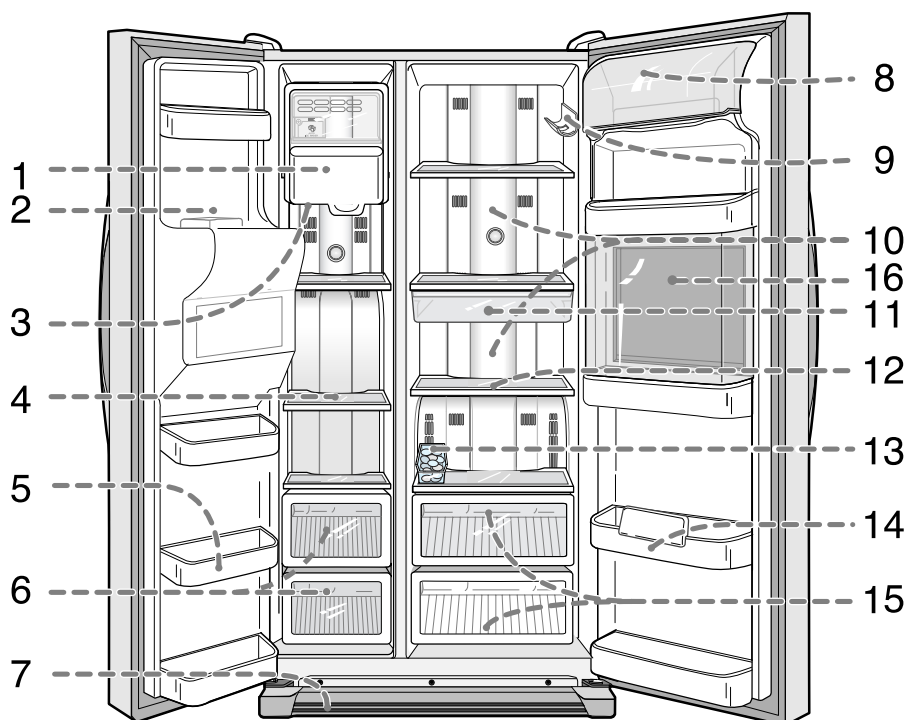

FREEZER

REFRIGERATOR

- | | |
|---------------------|---------------------|
| ① ICE-MAKER | ⑧ COVER-GUARD |
| ② ICE-CHUTE | ⑨ SHELF-WINE |
| ③ LAMP-INCANDESCENT | ⑩ LAMP-INCANDESCENT |
| ④ SHELF | ⑪ TRAY-CHILLED ROOM |
| ⑤ GUARD | ⑫ SHELF |
| ⑥ CASE-BASKET | ⑬ TRAY-EGG |
| ⑦ COVER-LEG, FRONT | ⑭ GUARD |
| | ⑮ CASE-VEGETABLE |
| | ⑯ HOME-BAR |

6. Freezing Cycle & Cold Air Circulation Course in Refrigerator

6-1) Freezing Cycle

COMPRESSOR → WIRE-COND → SIDE CLUSTER PIPE → HOT PIPE → DRYER
→ CAPILLARY TUBE → REFRIGERATOR EVAPORATOR → FREEZER EVAPORATOR
→ ACCUMULATOR → SUCTION PIPE → COMPRESSOR

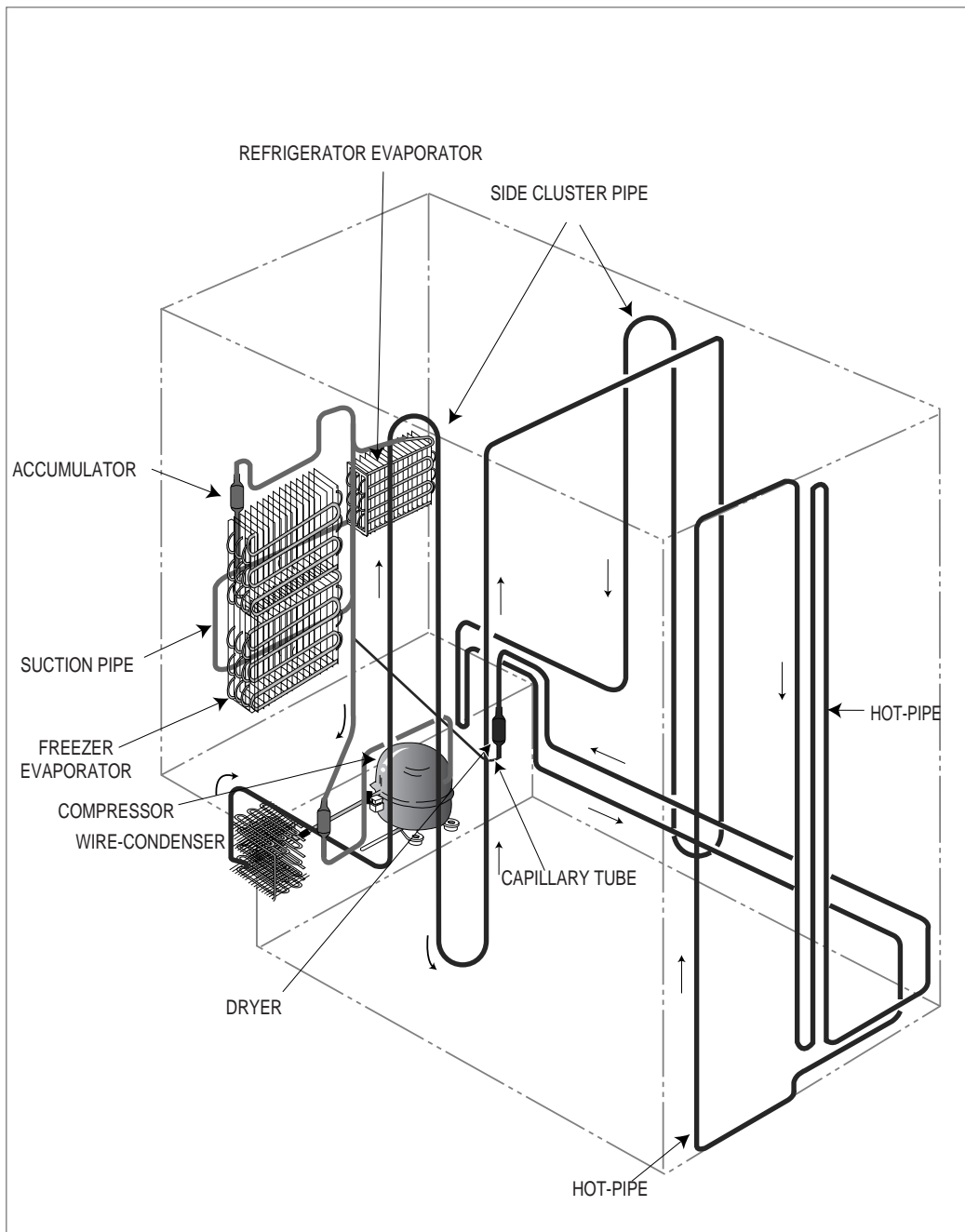

6-2) Cold Air Circulation Course in Refrigerator (Cold Air Passage Circulation Course)

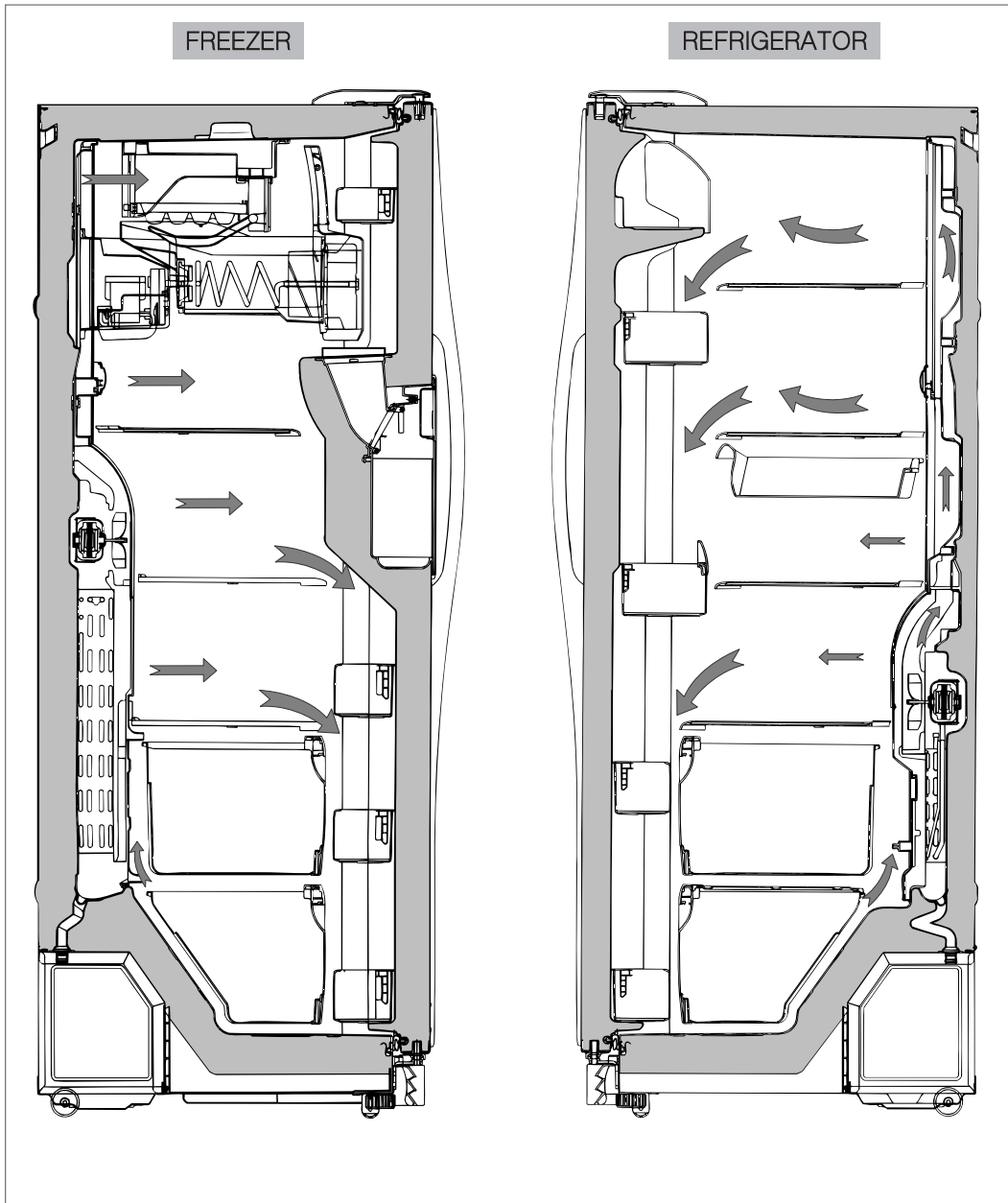

7. Function & Operating Instruction of Refrigerator

7-1) Temperature Control Function

1) Basic and with Home Bar Models

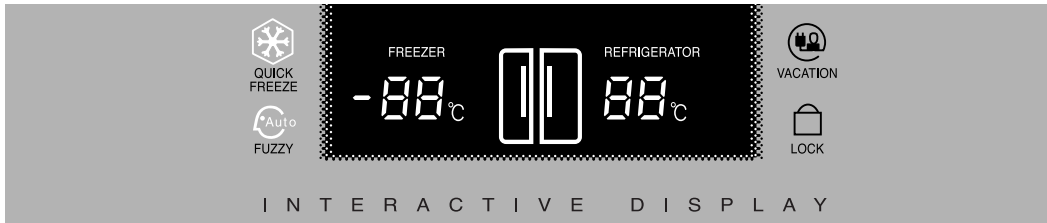

2) Dispenser and with Home Bar Models

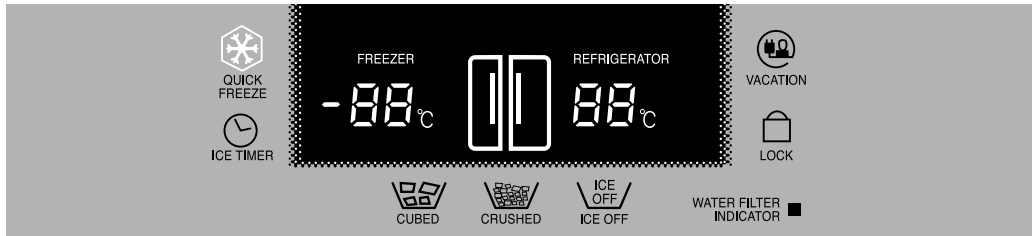

7-2) Temperature Control Function

① Temperature selecting function of freezer

- 1) At initial Power On, -20°C is selected automatically.
- 2) Select one button for 13 levels of -14°C ~ -26°C.
- 3) 1°C drops per each pressing of temperature selection button of freezer.

Division	At Initial Power On	One Time Press	...	6 Times Press	7 Times Press	...	12 Times Press
Display Change	-20°C	-21°C	→	-26°C	-14°C	→	-19°C

② Temperature selecting function of Refrigerator

- 1) At initial Power On, 3°C is selected automatically.
- 2) Select one button for 9 levels of 7°C ~ -1°C.
- 3) 1°C drops per each pressing of temperature selection button of Refrigerator.

Division	At Initial Power On	One Time Press	...	4 Times Press	5 Times Press	...	8 Times Press
Display Change	3°C	2°C	→	-1°C	7°C	→	4°C

* Reference (terms explanation)

- 1) F Room: freezer 2) R Room: Refrigerator 3) F-FAN: fan motor in freezer 4) R-FAN: fan motor in Refrigerator 5) COMP: compressor

*** Reference**

Temperature of table on previous page is temperature of center part of 1/3 height of Refrigerator/Freezer compartments. It is temperature data at unload state. When actually used, temperature may differ according to surrounding condition and use frequency. The table displays general characteristic of temperature.

7-3) Function of Quick Freeze & Vacation

- Select extra Quick Freeze & Vacation button.
 - Whenever Quick Freeze & Vacation button is pressed, selection/ cancellation (corresponding lamp On/Off) is repeated.
 - When Quick Freeze & Vacation is selected, temperature setup of freezer and Refrigerator does not change.
 - At state of selecting Quick Freeze & Vacation, change of temperature setup of freezer and Refrigerator is possible.
- ① Quick Freeze Function
- 1) When Quick Freeze function is selected, COMP and F-FAN operates continuously for 2 and half hours.
 - 2) While Quick Freeze function is working, Refrigerator operates under present setup condition.
 - 3) When Quick Freeze function is completed (after continuous operation of COMP, F-FAN for 2 and half hours), Quick Freeze lamp lights out automatically and operates according to setup temperature of freezer.
- ② Vacation Function
- 1) When Vacation is selected, Refrigerator fan is turned off.
 - 2) Though Vacation function is selected, Refrigerator fan does not turned off but turned on for initial 5 minutes.
 - 3) When Vacation function is selected and Ice Timer is set, Vacation function completes automatically when Ice Maker works by Ice Timer function. Then Refrigerator fan operates according to temperature setup of Refrigerator. (explained in detail at Ice Timer function)
 - 4) Vacation function is selected/ canceled by Vacation button. It can be canceled by temperature control button of Refrigerator while Vacation function is selected.
 - 5) While Vacation function is working, Vacation lamp is ON, and temperature display of Refrigerator is OFF.

*** Reference**

If Quick Freeze function is selected when freezer temperature is over -10°C and Refrigerator temperature is over $+10^{\circ}\text{C}$ like the condition of initial Power ON, Refrigerator Fan becomes OFF until freezer temperature drops under certain temperature. When freezer temperature becomes under certain temperature, Refrigerator Fan operates.

7-4) Alarm Function

- ① Button Touch Sound (“Ding-Dong” Sound)
 - 1) Input confirmation sound of “Ding-Dong” sounds when each button of Control Panel is pressed.
 - 2) “Ding-Dong” doesn’t sound if more than two keys are pressed at the same time or buttons are wrongly operated.

- ② Door-Open Alarm Sound (“Ding-Dong” Sound)
 - 1) If door of freezer or Refrigerator remains open over 2 minutes, alarm sounds ten times.
 - 2) If door remains open continually afterward, alarm repeats ten times per one minute cycle.
 - 3) Alarm stops immediately when door of freezer or Refrigerator is closed.

- ③ Forced Operation & Forced Defrost Alarm Sound (“Beep” Sound)
 - 1) If forced operation or forced defrost is selected, “Beep” sound occurs.
 - 2) If forced operation is selected, alarm sound occurs until automatic cancellation (after 24 hour’s forced operation) or cancellation function is selected.
 - 3) Also in case of forced defrost, alarm sound occurs until defrost is completed (including pause) or cancellation function is selected.

7-5) Defrost Function

- ① At time of initial Power On, defrost function works for both freezer and Refrigerator at the same time, when integrating time of Comp On is over 4 hours.
- ② Afterward defrost cycle is changeable according to use condition or surrounding environment from 6 hrs. to 38 hrs..
- ③ After completing the initial defrost, PRE-COOL function works for 20 min. to minimize temperature increase by defrost work. However, PRE-COOL function is determined according to temperature in Refrigerator at the point of defrost time.
- ④ If F-room temperature is over -21°C , PRE-COOL function works for F-room. If F room temperature is below -21°C , PRE-COOL function does not work.

7-6) Test Function

- Test function is for test, process inspection and SVC of PCB and product.
- After selecting test S/W and confirming function of product, turn on power switch again to operate self-inspection function.
- If you press Quick Freezer Key on Display Panel and temperature control Key in R-room for more than 8 seconds, all Displays will be turned off and continue operating in Test Mode. At this moment, if any key is pressed among freezer temperature control key, Refrigerator temperature control key, quick freeze key or vacation key, it operates as the test button.

※ F-room : Freezer, R room : Refrigerator

① Forced Operating Function

- 1) In the state where display panel was converted into test mode, if test button is selected once, COMP will operate immediately without 5 minute delay function. Therefore, forced operation is conducted at the very moment of COMP OFF, over load may be caused. Please be careful.
- 2) If forced operation is selected, freezer and Refrigerator is set to automatic, and the temperature of freezer is set to “-26°C” and Refrigerator is set to “1°C”, Comp and F-fan operates continuously, and R-fan in Refrigerator is controlled by “1°C” setup.
- 3) Forced operation is valid for 24hrs. That is, if 24hours. pass after selecting forced operation, simultaneous defrost in both Refrigerator and freezer is automatically carried out. And normal operation is carried out by present setup of Refrigerator and freezer.
- 4) Cancellation of forced operation in the middle of working is possible by turning on Power after turning it off (resetting), or by selecting test cancel mode shown in the item 3 below.
- 5) When forced operation works, alarm sound will continue until forced operation is completed. There is no alarm cancel function.

② Forced Defrost Function

- 1) In the state of forced operation, if display panel is converted into test mode and press the test button once more, forced operation is cancelled immediately, and evaporator defrost function of Refrigerator operates.
- 2) At this time, beep alarm sounds for 3sec. at the point of defrost, and 0.75sec. ON/0.25sec. off sound occurs during forced defrost function of Refrigerator works.
- 3) If above defrost function of Refrigerator is maintained, it operates normally after defrost is completed.
- 4) While forced defrost function of Refrigerator operates, pressing the test button once more enables simultaneous defrost for both freezer and Refrigerator.
- 5) At this time, beep alarm also sounds for 3sec. at the point of defrost, and 0.75sec. ON/ 0.25sec. off sound occurs continually until simultaneous defrost of F and R is completed.

③ Test Cancel Mode











- 1) In the state of simultaneous defrost of freezer and Refrigerator, if display panel is converted into test mode, and test button is pressed once more, defrost of both freezer and Refrigeration is cancelled immediately and resumes normal operation .

※ Reference

It works step by step in test function. It does not change from 1 step (forced operation) to 4 step (test cancel mode) directly. It operates corresponding function only after it goes through the previous step. While test function works, it is most desirable to turn off main power and then turn it on.

7-7) Self-diagnosis Function

- ① Self-diagnosis Function at the time of initial power is on.
- 1) When the initial power is applied to Refrigerator, all lamps light and conduct self-diagnosis function internally.
 - 2) If result shows no fault, display will go into the initial normal lighting state.
 - 3) If result shows any fault, corresponding led is turned on and off and alarm sounds.
 - 4) Error sign of self-diagnosis continues until all defects of parts are repaired or self-checkup function is cancelled.
 - 5) If all corresponding parts are repaired completely, display will go into the normal mode state.
 - 6) After repairing Refrigerator, turn on switch again after turning it off to make it sure if Refrigerator is properly repaired.
 - 7) Therefore, in case open & short related problem of sensor needs to be confirmed during A/S, turn off the power of Refrigerator and turned it on again to operate self-Diagnosis function. Then sensor function can be checked.
 - 8) When any defect occurs, corresponding display signs are shown as in the following chart.

NO	Items	Corresponding LED	Defect Content	Remark
01	ICE-MAKER SENSOR	REFRIGERATOR 	Defect of wire connecting system due to badness of Open/Short related aspect of Sensor which is equipped at the beneath of ice-making bowl	When temperature sensing of R-sensor is more than +50°C and less than -50°C.
02	Refrigerator R-sensor	REFRIGERATOR 	Missing sensor housing of R-room, contact defects, disconnection of wires, defect of short-circuit sensor itself, etc.	Defect is indicated when temperature sensing of R-sensor is more than +50°C and less than -50°C.
03	Refrigerator defrost sensor	REFRIGERATOR 	Missing sensor housing of R-room, contact defects, disconnection of wires, defect of short-circuit sensor itself, etc.	Defect is indicated when temperature sensing of R-sensor is more than +50°C and less than -50°C.
04	R-fan motor Error	REFRIGERATOR 	Interference of Fan due to frost, etc., un-insertion of connector, disconnection, etc.	Occurrence of the case where Fan Motor of inner refrigerator room becomes to operate under about 600rpm at the normal operation condition or stops driving.
05	ICE-MAKER KIT	REFRIGERATOR 	Defect of micro S/W in Gear box, motor, gear and other defect in wire system	When normal operation is not done until ice-isolating motion is attempted 3 times (only ice-making function model corresponds).
06	Outside Air Sensor	FREEZER 	Missing of outside air sensor housing inside of PCB base of top part of Refrigerator, contact defect, disconnection of wires, defect of short-circuit sensor itself, etc.	Badness is indicated when temperature sensing of Outside Air Sensor is more than +50°C and less than -50°C.
07	Freezer F-sensor	FREEZER 	Missing sensor housing in F-room, contact defects, disconnection of wires, defect of short-circuit sensor itself, etc.	Defect is indicated when temperature sensing of F-sensor is more than +50°C and less than -50°C.
08	Freezer defrost-sensor	FREEZER 	Missing defrost-sensor housing in evaporator of F- room, contact defects, disconnection of wires, defect of short-circuit sensor itself, etc.	Defect is indicated when temperature sensing of F-sensor is more than +50°C and less than -50°C.
09	F-fan motor Error	FREEZER 	Interference of Fan due to frost, etc., un-insertion of connector, disconnection, etc.	Occurrence of the case where Fan Motor of inner freezer room becomes to operate under about 600rpm at the normal operation condition or stops driving.
10	C-fan motor Error	FREEZER 	Un-insertion of connector, disconnection, etc.	Occurrence of the case where Comp Cooling Fan Motor becomes to operate under about 600rpm at the normal operation condition or stops driving.

Note) This self-Diagnosis works only when the open/short related aspect of sensor is bad. Minute feature change of sensor is not judged as defect if it does not get rid of the extent of temperature sensor described in Remark so that it is indicated as normal.

② Self-Diagnosis Function in Normal Operation

- 1) Under normal operation of Refrigerator, if you press “Quick freeze” and “Vacation” button at the same time for 6sec., temperature setup display will proceed On/Off blink of all for 2sec. at 0.5sec. interval.
If you press “Quick freeze” and “Vacation” button continuously at the same time for about 8sec. including 2sec. of repetition of LED’ s On/Off, self-Diagnosis function is selected.
- 2) At this moment, it goes into self-Diagnosis function with “Ding-dong” buzzer sound.
- 3) When Error occurs, it is restored to normal state regardless of defect repairing after signal lasts for 30sec. (“Ding-dong” buzzer sound).
- 4) While it is operating self-Diagnosis function, it does not accept input of button.

7-8) Load Condition Indicating Function

- ① In normal operation, if you press “Quick freeze” and “Vacation” button at the same time for 6 sec., all setup display of freezer and Refrigerator are turned on. If you hand off from the button at this moment, temperature setup display of freezer and Refrigerator will proceed On/Off blink of all for 2sec. at 0.5sec. interval. While On/Off blink is processing, if you press the temperature setup button, it goes into load condition indicating function (with ding-dong buzzer sound).
- ② Load condition indicating mode shows from which load Micom signal outputs at present. However, it only shows that micom signal is outputted and does not confirm whether load is actually operating or not. That is, even if load is displayed as it is operating, load may not operate because of actual defect of load or defect of relay on PCB. During A/S, you can use this function by applying the main function.
- ③ Time required to indicate is 30 sec.. After 30sec., it is automatically restored to the setup state before its function.
- ④ Corresponding display indication about load condition is shown as in the following table.

*** Load Mode Check List**

NO	Display Content	Operation Content
①	R-fan high	R-fan high speed operation indication
②	R-fan low	R-fan low speed operation indication
③	R-Def-Heater	R room defrost-heater operation indication
④	Start Mode	indication operation stage (Not important)
⑤	Overload Mode	when ambient temperature is more than 34°C
⑥	Low-temperature Mode	when ambient temperature is less than 17°C
⑦	Comp	Comp operation indication
⑧	F-fan high	F-fan high-speed operation indication
⑨	F-fan low	F-fan low-speed operation indication
⑩	F-Def-Heater	F room defrost-heater operation indication
⑪	C-fan high	C-fan high-speed rotation operation indication
⑫	C-fan low	C-fan low-speed rotation operation indication

Press both buttons 6 sec, simultaneously, all LED lights are turned on and off twice.
At this time press button ③.

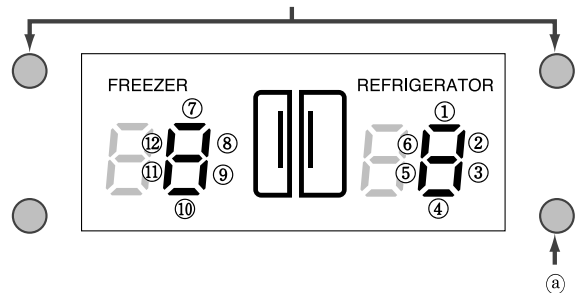

* For load under operation, corresponding LED lights on.

7-9) Function of Ice/Water Dispenser when they are equipped.

- This function only applies to a model equipped with ice-maker.
 - This function is limited to a model from which ice and water can be taken out from outside without opening door.
- ① Cube Ice / Crushed Ice/ Stop (Off) Function
- 1) At the time of initial power on, when inside temperature of freezer is more than 5°C, Cube Ice LED light on display is lit on, and Crushed Ice LED light keeps light-off state. But when power is turned on, if inside temperature of freezer is less than 5°C, Micom recalls form of ice which was set up before power off so that it displays the memorized ice form.
 - 2) “Cube” → “Crushed” → “Ice Off” is selected in turn by ice selecting Key.
 - 3) In case of selecting “Crushed” mode, it operates Gear Motor to eject crushed ice to outside when ice lever operates as ice is made in the bowl of ice machine.
 - 4) In case of selecting “Cube” mode, Gear Motor and ice solenoid operate to eject cube ice to the outside when ice lever operates as ice is made in the vessel of ice machine.
 - 5) If “Ice Off” is selected, it stops only ice-making function of ice-maker so that ice is not made.
- ◆ At the moment of selecting “Ice Off”, ice-making function stops. But, if it is in the process of ice-isolating, returning to horizontal state and supplying water, it maintains stoppage state after water supply is completed.
 - ◆ Even when “Ice-Off” function is operating, ice eject lever operates normally. This is not a defect. Therefore, remained ice in the ice container can be used normally.
- ② Ice Timer Function
- 1) If you press ice timer button, it is automatically set to Ice-Off mode regardless of present setup condition of ice mode (Cube / Crushed / Ice Off), and ice lamp is turned on. And time is set to 3 days on temperature control display of freezer at first. And each time you press the ice button, the number increases one by one. And if it reaches 30 days, it resumes from 3 days.
 - 2) Among ice timer functions, if you press ice selecting key, ice timer function is cancelled.
 - 3) If reservation is made by ice timer button, setup temperature of freezer returns to temperature display of freezer after 5sec.. At this moment, if ice timer button is pressed again, it displays the previous reserved date again. 1-2 days before the reserved date is completed, ice maker starts operating. And when the reserved date is completed, more than half of ice bucket is filled.
 - 4) If ice timer is reserved and vacation function operates, vacation function ends at the same time when ice timer function ends.

5) The following are examples for use.

◆ In case of selecting vacation function only

If you press "vacation" button, Refrigerator will not operate and freezer will operate only. In case you select this function, take out all foods in the Refrigerator. And "Ice Off" is automatically selected among ice modes, so ice bucket should be empty and water supply valve should be turned off.

◆ In case of selecting ice timer function only

In case you press "Ice Timer" button to select date as explained above, and not selecting "Vacation" function so that Refrigerator continues to operate, ice mode is selected as "Ice Off" and ice is stored in the bucket when you return. Therefore, do not lock the water supply valve.

◆ In case of selecting both vacation and ice timer function

In case you press "Ice Timer" button and "Ice Timer" button to select date to select date as explained above, or if you press "Ice Timer" button to select date and press "Vacation" button afterward, Refrigerator does not operate but freezer operates only, and ice mode is automatically selected as "Ice Off". So you must take out all foods in Refrigerator, empty ice in the ice bucket, check water leakage on valves, other hoses and connection parts without locking water supply valve. When "Vacation" function is cancelled, Refrigerator resumes its operation.

③ Ice Dispenser Function (Cover Ice Route Solenoid Valve)

- 1) After 8sec. from initial power on, solenoid of ice exit operates once. This is the function to prevent interruption of electric service when ice exit is open. So this is not a defect.
- 2) With turning the dispenser S/W from on to off and ice ejecting is completed, 5sec. after turning off S/W, ice exit is closed because cover ice route solenoid of ice dispenser operates.

④ Water Dispenser Function

- 1) This function is a system of direct connection with water supply. When water lever is pressed, water solenoid valve which is equipped at the right side of machine room opens so as to operate to eject water. However, it has no function to control on Micom PCB. Therefore, if there happens any defect at water eject function, check and repair solenoid itself, wire connecting connector, connecting tube and state of water supply.

⑤ Water Filter Indicator Function

- 1) After the initial power on, indication lamp is displayed in green light. After 5 months passed, it is displayed in orange light, and 1 month after this, it is displayed in red light. This is memorized by EEPROM in Micom PCB, so it counts the passed time continually though the power is turned on again after it was turned off.
- 2) If you press ice selecting button and ice-making stop button at the same time for 25sec. continuously, indication lamp lights in green color. And it becomes orange after 5 months from this moment. And it displays red after 1 month from the moment.
- 3) If you press ice selecting button and ice-making stop button at the same time for 5 sec., indication lamp is turned off and water filter indicator function stops. At this moment, passed time is not counted.
- 4) At the state where the function is stopped, if you press ice selecting button and ice-making stop button at the same time for 25sec. continuously, "Green" light is turned on and water filter indicator function will resume. And it becomes orange light after 5 months from this moment. And it displays red light after 1 month from the moment.

7-10) Restoring Function of Operation State in case of Power Stoppage

- 1) In case power is applied to prevent customer from nonsense call about initialization of freezer and Refrigerator at -20°C and 3°C respectively when a momentary power stoppage (not a long-term power stoppage) occurs while Refrigerator is operating, it operates in two ways. The first one is initialization by judging the temperature of inside of freezer, and the second one is restoration of operation state.
- 2) At the initial power on, in case temperature of the inside of freezer is judged as about less than $+5^{\circ}\text{C}$, it is regarded as momentary power stoppage during operation. Therefore, functions related with panel display such as Quick Freeze, Vacation, Freezer setup, Refrigerator setup, Ice timer, Form of ice, etc. are restored.
- 3) At the initial power on, in case temperature of the inside of freezer is about more than $+5^{\circ}\text{C}$, it is regarded as long-term power stoppage. In this case, panel display is initialized (Quick off, Vacation off, Freezer is set to -20°C , Refrigerator is set to 3°C , Ice timer off, Cube selecting).
- 4) Ice timer function and water filter indication function are not initialized in case of power stoppage. But during power stoppage, time count does not progress because Micom in PCB does not operate because power source is not supplied.

8-4) Door S/W Sensing Circuit

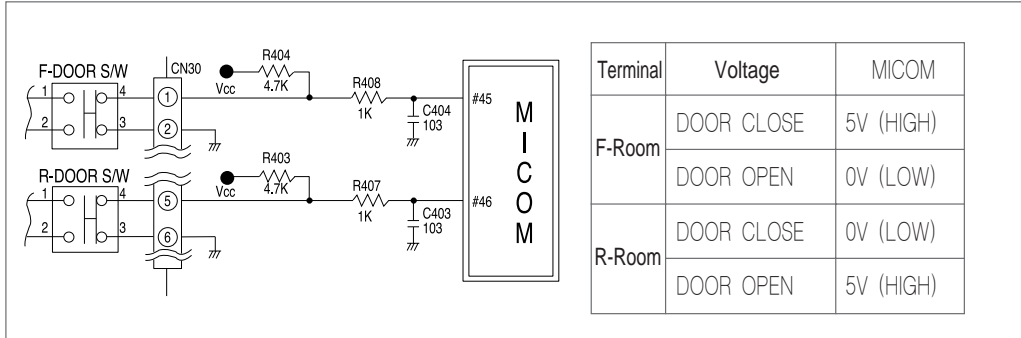

For door open sensing of F room, ② of CN30 is connected to the ground. For ①, Vcc(DC 5V) is supplied through resistance R404(4.7kΩ), and “LOW” (0V)/” HIGH(5V)” is applied to MICOM by open/close of the F room door so that it can sense open/close of the F room door. For door open sensing of R room, ⑥ of CN30 is connected to the ground. For ⑤, Vcc(DC 5V) is supplied through resistance R403(4.7kΩ), and “LOW” (0V)/” HIGH(5V)” is applied to MICOM by open/close of the R room door so that it can sense open/close of the R room door. At this time, if there is any defect at the door S/W, the corresponding fan inside the Refrigerator does not work or alarming function works. Therefore, the door S/W must be checked in case of A/S. That is, if door opens, the corresponding fan inside the Refrigerator stops without fail. When connection point of S/W has defect, MICOM judges that door is open so that it stops the fan though the door is closed.

8-5) Temperature Sensing Circuit Part

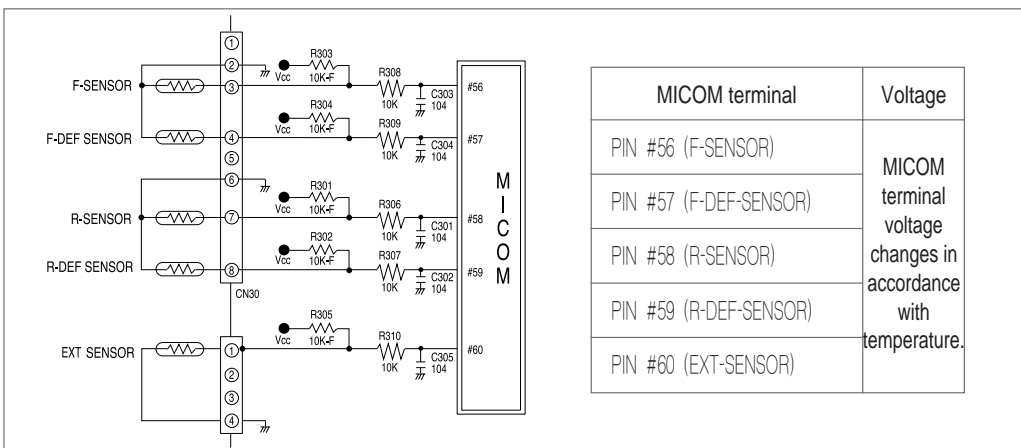

Sensor uses thermistor which has temperature coefficient of negative resistance. When temperature rises, resistance value gets smaller, and when temperature falls, resistance value gets larger. R306~R310, C301~C305 are parts for noise prevention, which are not related to temperature sensing characteristic. In case of F-SENSOR, if setup voltage inputted to MICOM Referred to as Vf, $V_f = (R_{th} \cdot V_{cc}) / (R_{303} + R_{th})$. Here, Rth is resistance value of thermistor corresponding to temperature. See conversion table of "Refer 6" of this manual on resistance and voltage of sensor about temperature for Reference. As terminal voltage of MICOM corresponding to temperature is also designated, Refer to it at A/S time.

8-6) Key Scan & Display Circuit Part

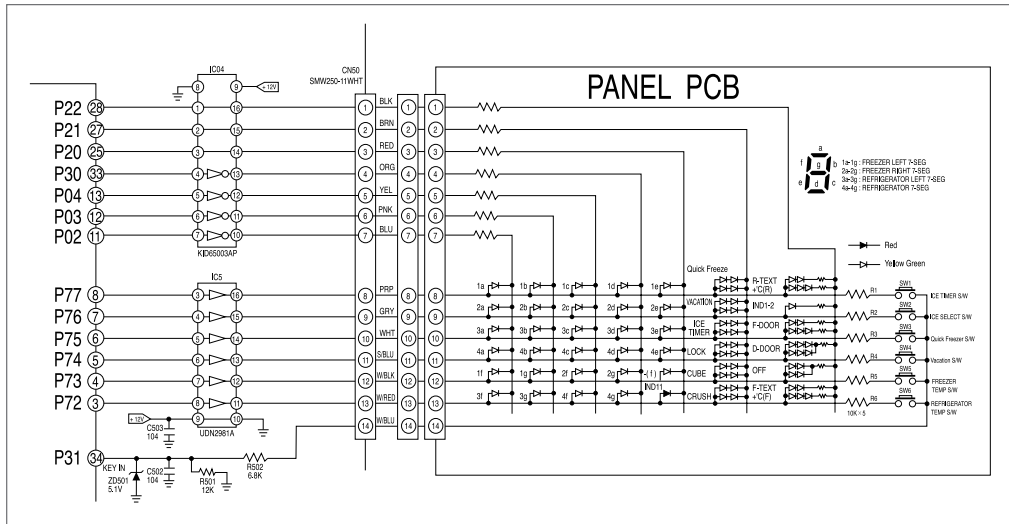

① Key Scan and Display Operation

As is seen on each wave form of the following, send "HIGH" output in an order of MICOM PIN NO #3→#4→#5→#6→#7→#8 for 2msec in a cycle of 12msec using six terminals of MICOM NO #3, 4, 5, 6, 7, 8. This signal appears onto output terminal through input terminal of IC05(UDN2981 or KID65783AP). At this time, peak-to-peak voltage of the spherical wave is about 11V(DC RMS1.5), and form of output wave form is like the drawing 1.

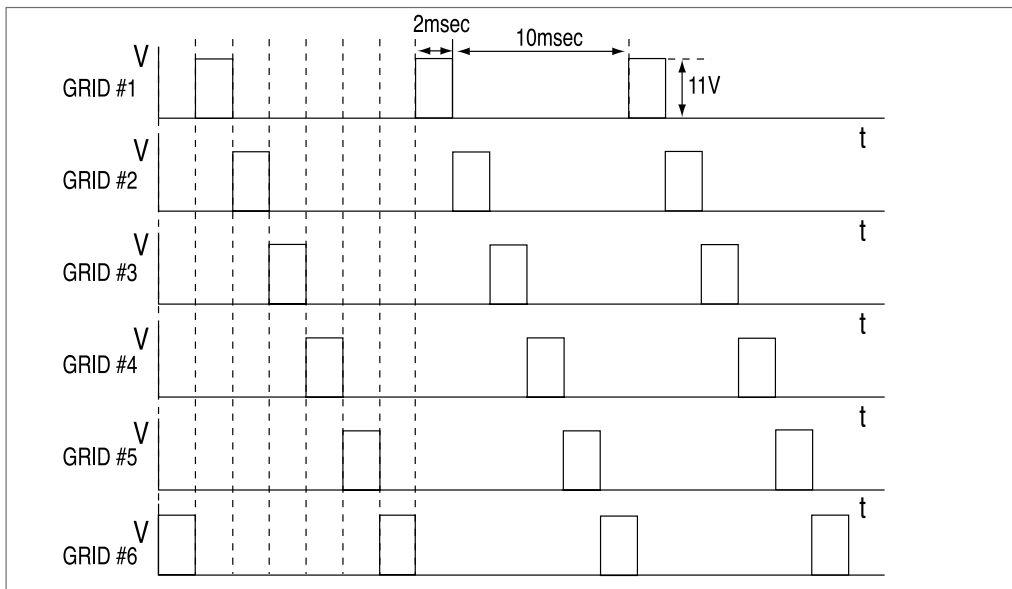

② Key Scan

When the wave form of GRID#2 is outputted, this signal is provided to SW6 button through the resistance of 10kΩ. When SW6 is pressed at this time, signal gets smaller by R501(12kΩ), and about 4.5V of peak-to-peak voltage is applied to MICOM. MICOM judges that the wave form of GRID#1 is inputted, and changes function corresponding to SW6 KEY. In this way, each wave form of GRID is recognized.

8-7) Load Operation Circuit Part

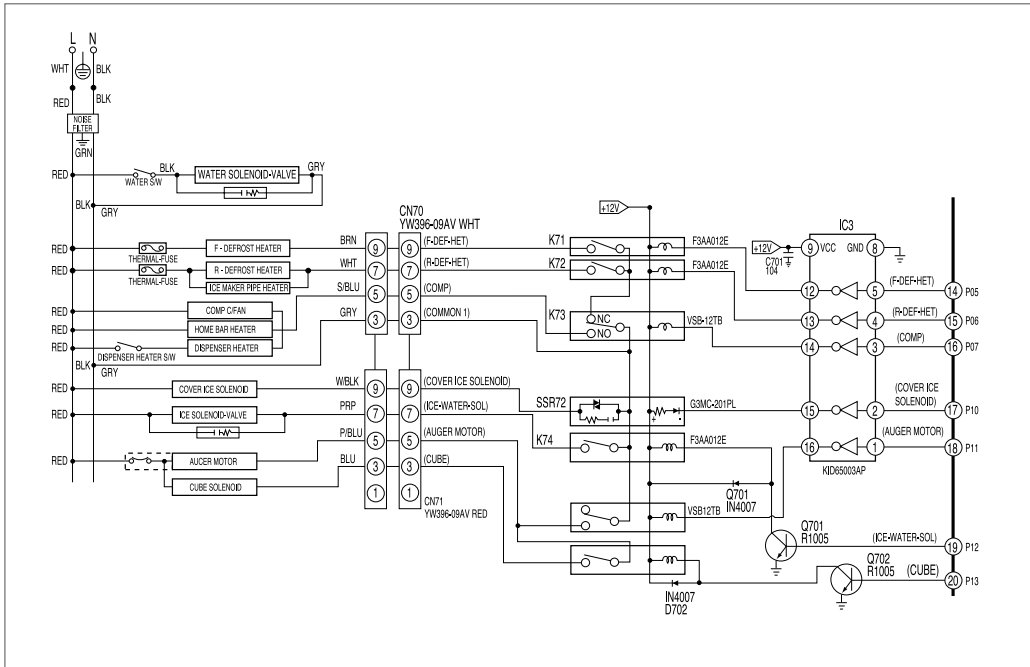

When “HIGH” signal is applied to INPUT terminal of IC03(KID65003AP) from MICOM PIN NO #16(P07), IC is turned on. At this time, V12(DC12V) which is applied to the one terminal of coil of COMP relay flows to ground through output of IC03. Then core generates magnetic field to turn on the connection point, and it applies voltage of 230V to COMP load to turn on COMP. When MICOM PIN NO #16 changes to “LOW” state, electricity cannot flow to COMP relay coil because IC is turned off. So relay connection point becomes to OFF state and stops COMP.

① COMP & F,R Defrost Heater Inter-operation Explanation

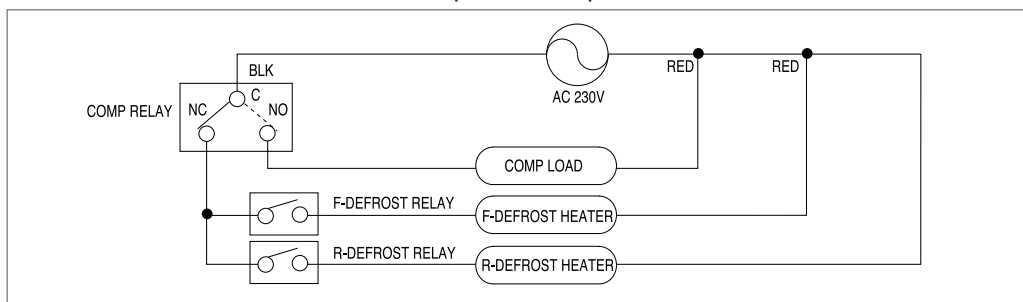

Like the above block diagram, operation of F, R defrost heater is determined according to the operation of relay for COMP. When COMP relay is connected to NO terminal, COMP operates. However, in case of F, R defrost heater, electricity does not pass through the heater though relay works. But, if COMP relay is connected to MC terminal, COMP does not operate and heater gets electricity according to operation of F, R defrost relay.

※ Purpose of application of above circuit: It aims to interrupt electricity passage through F, R defrost heater even though F, R defrost relay is bad while COMP is operating.

8-8) BLDC Motor Operation Circuit Part

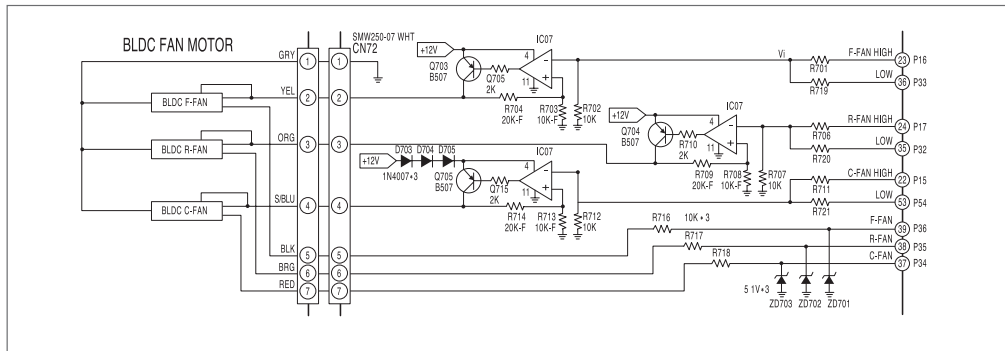

- In case Fan Motor is locked, therefore, when Fan Motor is constrained to less than about 600rpm in order to prevent over-current to the power source group, PIN #39, #38 and #37 sense it so that they can stop Fan Motor operation.

If Fan Motor operation is stopped by this function, it becomes to re-operate every 10 second. If Motor Connector is separated under the state where the power source is applied during service, Micom recognizes it as Fan Motor is constrained so that Micom can stop Motor. Then Motor resumes to operate after 10 seconds.

However, there are a part of products which re-operate every about 5 minute among the products which were manufactured in February and March.

Therefore, when the product is completely repaired, confirm the repaired state with power-ON again after power-OFF if possible.

8-9) Various Option Function

- When pressing the temperature control s/w of freezer and vacation s/w for 12 sec. continuously at the same time, display is converted into option setup mode.
- When display is converted into option setup mode, every display except for temperature display of freezer and Refrigerator turns off like the following.

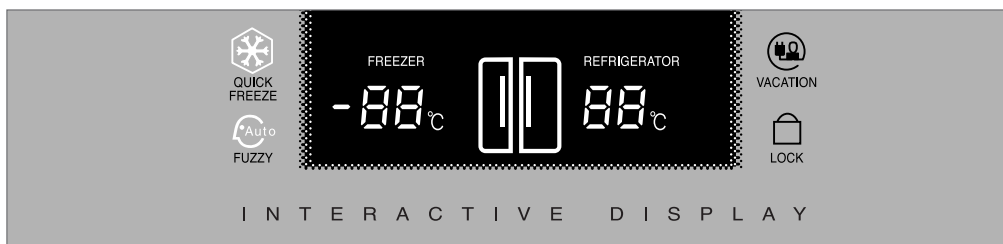

- On display like the above, temperature display of Refrigerator indicates items of option, and temperature display of freezer indicates setup value for each item. For the temperature display of Refrigerator, when temperature control s/w is pressed, option items increase, and when vacation s/w is pressed, option items decrease. For the temperature display of freezer, when temperature control s/w is pressed, option setup value increases, and when vacation s/w is pressed, option setup value decreases. If waiting for 20sec. after changing option by controlling s/w, option setup value is saved to EEPROM, and option setup mode is canceled automatically and restored normal display. For example, if you want to shift temperature of Refrigerator by -3°C by controlling option, follow the processes of below.

- 1) Press temperature control s/w and vacation s/w of freezer for more than 12 sec. simultaneously : all displays become off except temperature display of freezer and Refrigerator.
- 2) Pressing temperature control s/w of Refrigerator for one time, "1" is indicated on Refrigerator display : If indication "1" is displayed on Refrigerator display, it shows temperature setup of Refrigerator, and current temperature setup value of Refrigerator is indicated on temperature display of freezer.
- 3) If temperature display of freezer indicates "9" this time, check value which is set at present from the table in the next page. In this case, you can see that temperature is changed to $+1.0^{\circ}\text{C}$ compared to the standard temperature according to the table : Here, in order to change by -3.0°C , $(+1.0^{\circ}\text{C}) + (-3^{\circ}\text{C}) = -2.0^{\circ}\text{C}$ is calculated.
- 4) Now Refer to the table on the next page to change temperature to -2°C . Press temperature s/w and quick freeze s/w of freezer for temperature control display to indicate "4" : Waiting for 20sec. after setup, MICOM saves setup value to EEPROM and returns to the normal display and cancel option setup mode.

* Caution

When product is delivered, option function is set to EEPROM from the plant, therefore, Refrain from intentional change except for special case. Option function setup is completed only after it is returned to the normal display after 20sec.. So do not turn power off before display returns to the normal state.

8-10) Option Related to Temperature

■ Freezer Temperature Change Table

Set item	Refrigerator display
Freezer temperature change mode	"0"

● Example

- When set to -2.5°C , compared with the standard temperature of freezer

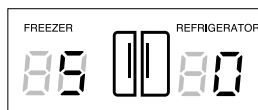

Temperature change	Freezer display	Temperature change	Freezer display
0	"0"	+ 0.5°C	"8"
- 0.5°C	"1"	+ 1.0°C	"9"
- 1.0°C	"2"	+ 1.5°C	"10"
- 1.5°C	"3"	+ 2.0°C	"11"
- 2.0°C	"4"	+ 2.5°C	"12"
- 2.5°C	"5"	+ 3.0°C	"13"
- 3.0°C	"6"	+ 3.5°C	"14"
- 3.5°C	"7"	+ 4.0°C	"15"

■ Refrigerator Temperature Change Table (● : corresponding lamp is on, ● : corresponding lamp is off)

Set item	Refrigerator display
Refrigerator temperature change mode	"1"

● Example

- When set to $+2.5^{\circ}\text{C}$, compared with the standard temperature of Refrigerator

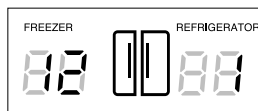

Temperature change	Freezer display	Temperature change	Freezer display
0	"0"	+ 0.5°C	"8"
- 0.5°C	"1"	+ 1.0°C	"9"
- 1.0°C	"2"	+ 1.5°C	"10"
- 1.5°C	"3"	+ 2.0°C	"11"
- 2.0°C	"4"	+ 2.5°C	"12"
- 2.5°C	"5"	+ 3.0°C	"13"
- 3.0°C	"6"	+ 3.5°C	"14"
- 3.5°C	"7"	+ 4.0°C	"15"

8-11) Option Related with Ice Maker

- Following options are applied only for models which are equipped with ice maker.
- It is water supply time option that operates when the flow sensor for time control function of water-supply for ice maker is out of order (identical with DIP s/w of existent ZIPEL).
- It is the temperature of ice making sensor which checks whether the ice of ice-maker of temperature change of ice making sensor freezes completely.

Set item	Refrigerator display
Ice maker water supply time	" 3 "

Water supply time	Freezer display
5sec	" 0 "
4sec	" 1 "
3sec	" 2 "
6sec	" 3 "
7sec	" 4 "
8sec	" 5 "
9sec	" 6 "
10sec	" 7 "
12sec	" 8 "
13sec	" 9 "
15sec	" 10 "
17sec	" 11 "
19sec	" 12 "
21sec	" 13 "
23sec	" 14 "
25sec	" 15 "

Set item	Refrigerator display
Ice making temperature	" 4 "

Temperature change	Freezer display
- 7°C	" 0 "
- 6°C	" 1 "
- 8°C	" 2 "
- 9°C	" 3 "
- 10°C	" 4 "
- 11°C	" 5 "
- 12°C	" 6 "
- 13°C	" 7 "

- Example
 - When ice making sensor is set to -10°C

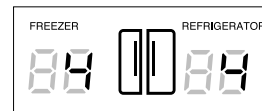

- When Refrigerator temperature display indicates "2", the data indicated on the freezer temperature display is the function which is not used in this model so that additional adjustment is not necessary.
- If Refrigerator temperature display is not selected more than "2" during option function is setting among models which are equipped with dispenser and ice-maker, replace the main PCB assembly.

- Example
 - When water supply time is set to 9sec.

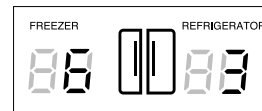

Note: If Refrigerator temperature control s/w and vacation s/w are used, several other options except the above functions are set. However, those points are omitted because they are not necessary part at the A/S time as they are items related with Refrigerator control function (Do not set options other than the above A/S manual contents).

9. Trouble Diagnosis & Repair Method

Pre-checkup

1. Check whether power cord is normally connected before repairs.
2. Practice checkup on the basis of Reference in the next page.

9-1) When power is not supplied

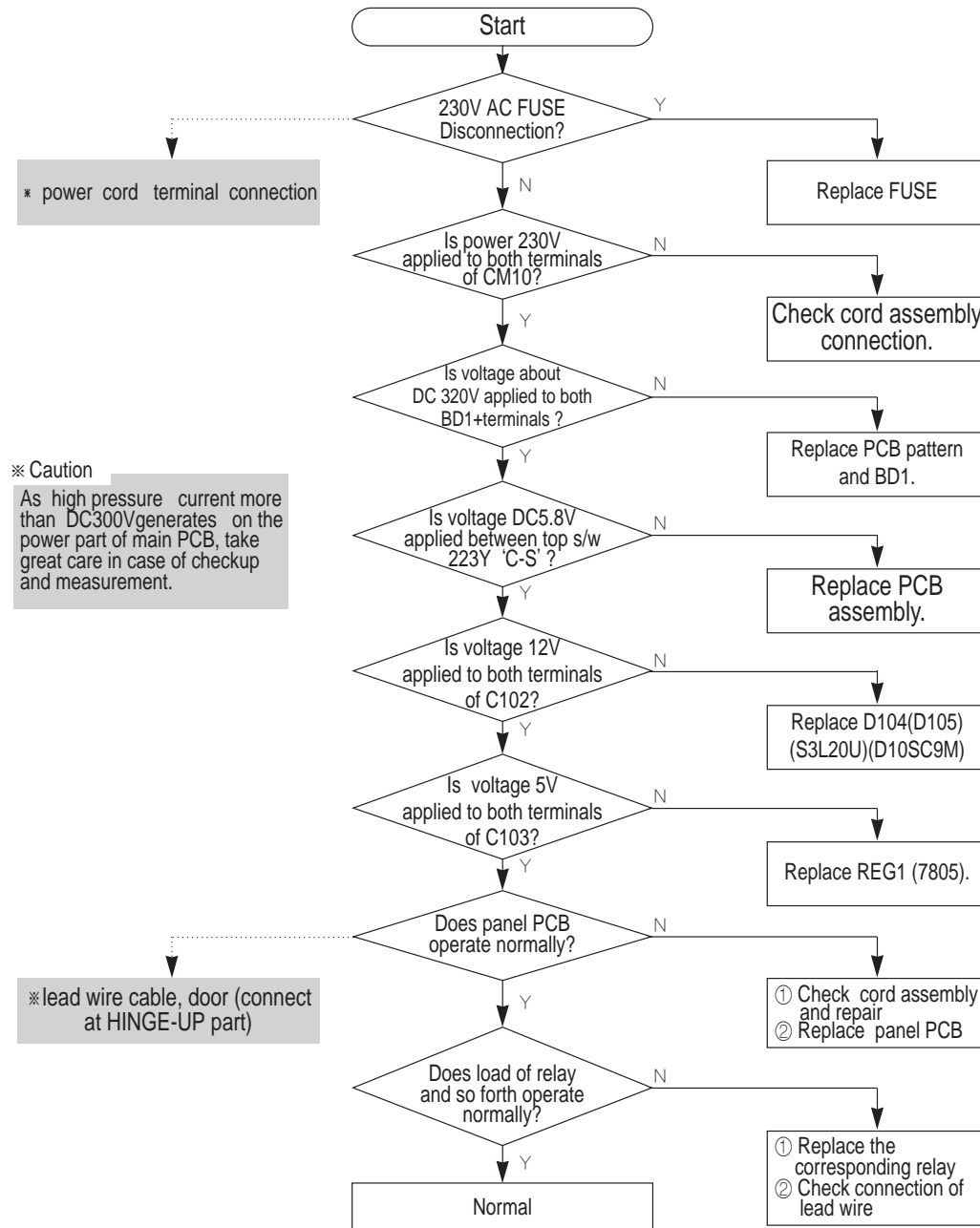

Pre-checkup

1. When power is applied initially, COMP works after 3~6 sec.. However, when COMP turns off during its operation, COMP doesn't work for 5min..
2. COMP doesn't work during defrost
3. If freezer sensor is not connected, it is sensed as low temperature and COMP doesn't work.

9-2) When COMP doesn't work

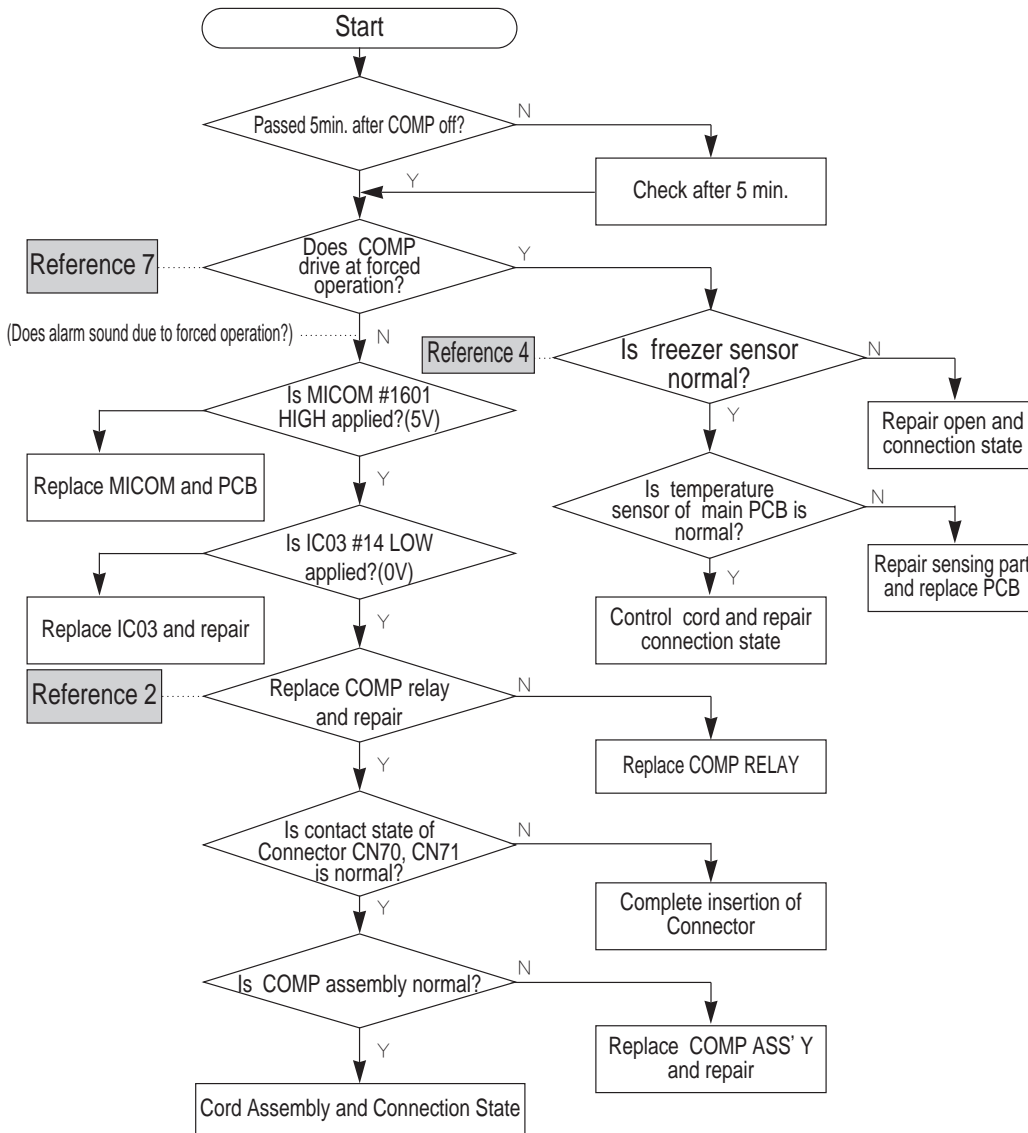

Judgment Condition

1. At the initial power on, cooling operation is normally carried out. However, after a certain time passes (when defrost time comes), badness occurs on Refrigerating and freezing work. It is a case where there is defect on defrost part. Checkout whether there is defect on defrost system by Referring this trouble diagnosis.

9-3) Defrost function does not work

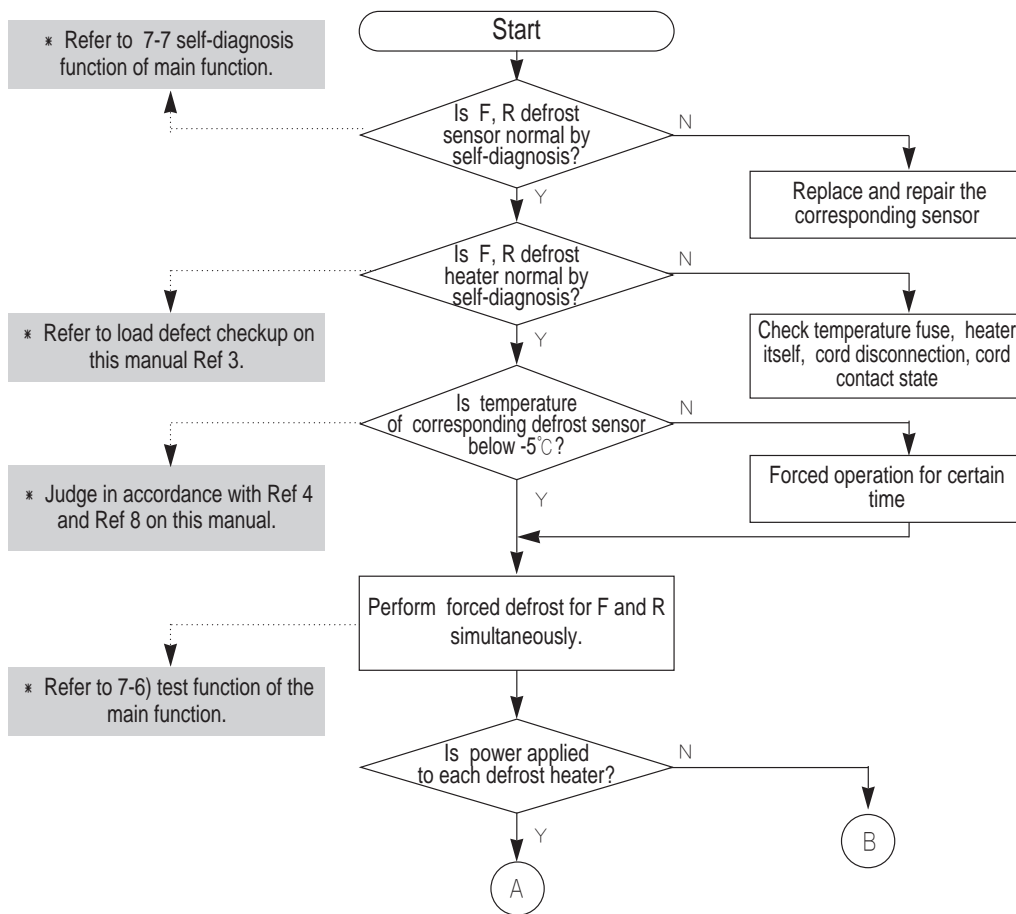

Reference

1. If each EVA-SENSOR of F room and R room has open or short-related defect, electricity does not flow to defrost heater and it returns to normal operation after pause time passes. Therefore, if the period when defrost heater does not work accumulates, Refrigerating and freezing badness results.
2. If temperature fuse which is a safety device is turned off, or defrost heater has wire disconnection, or relay on PCB is bad, defrost is done by natural temperature rise. In this case, period of COMP off according to defrost becomes very long so that badness on Refrigerating and freezing function results.

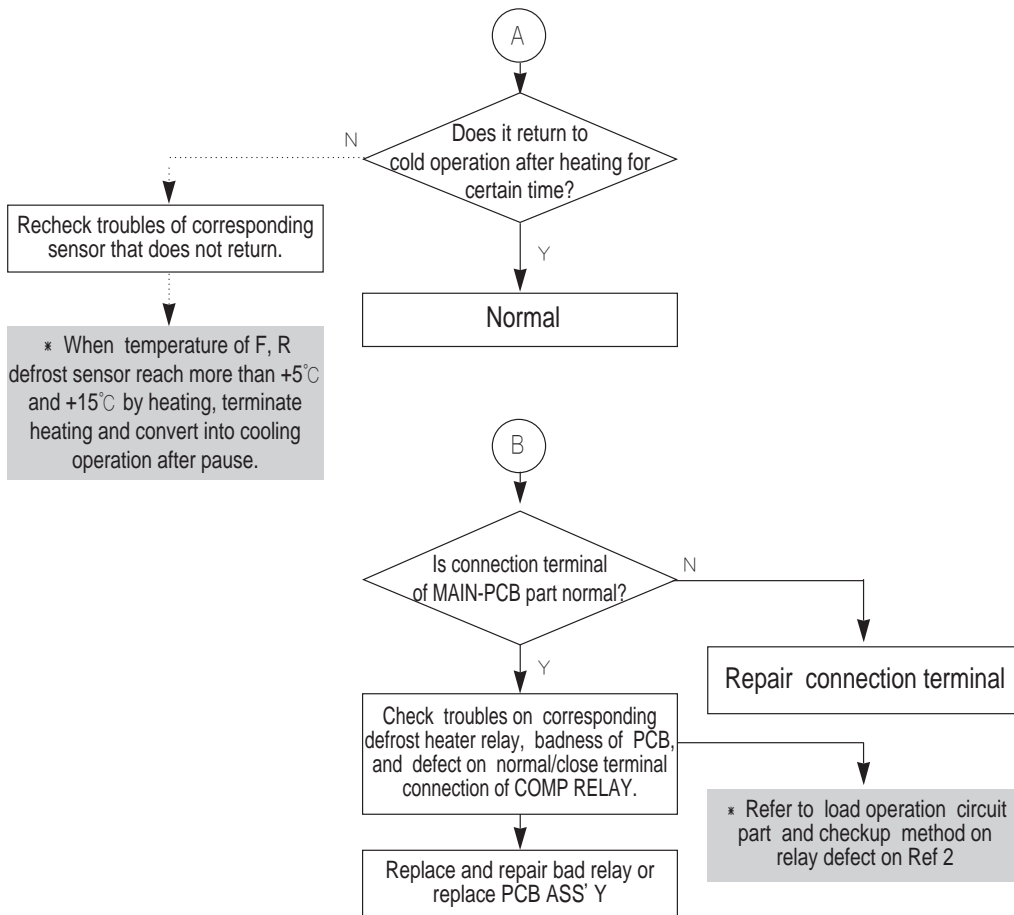

9-4) Self-diagnosis Abnormality Occurs

① When abnormality on outer temperature sensor occurs

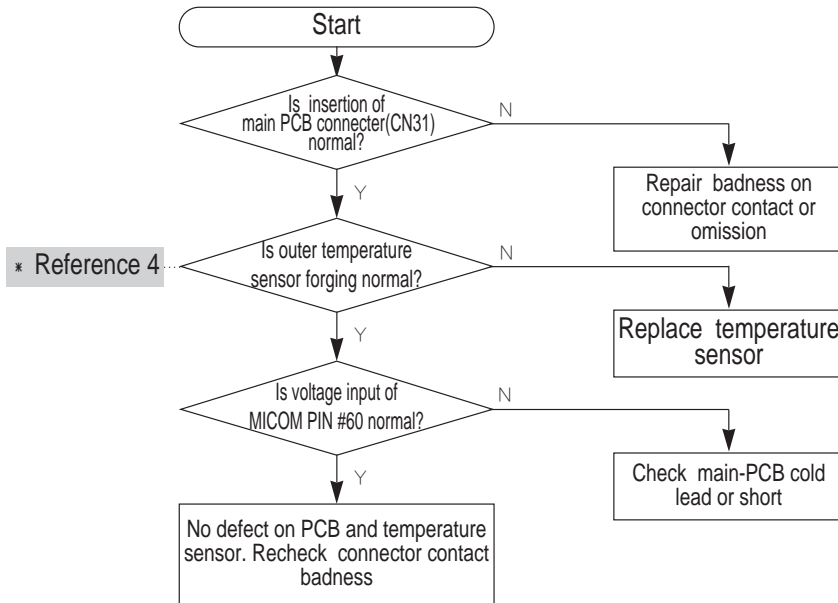

② When abnormality of temperature sensor of Refrigerator occurs

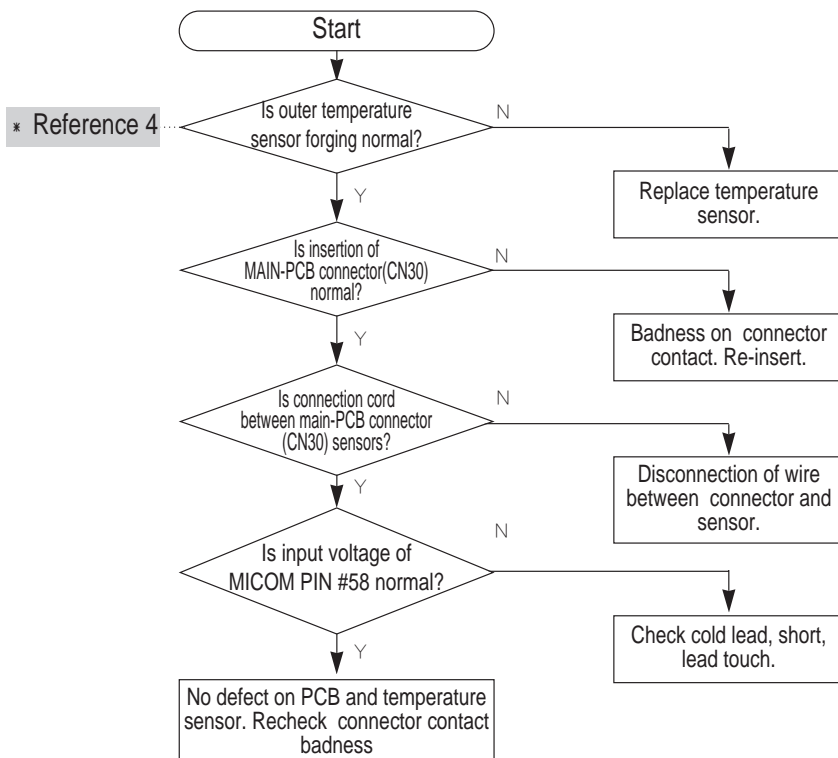

③ When abnormality on defrost sensor of Refrigerator occurs.

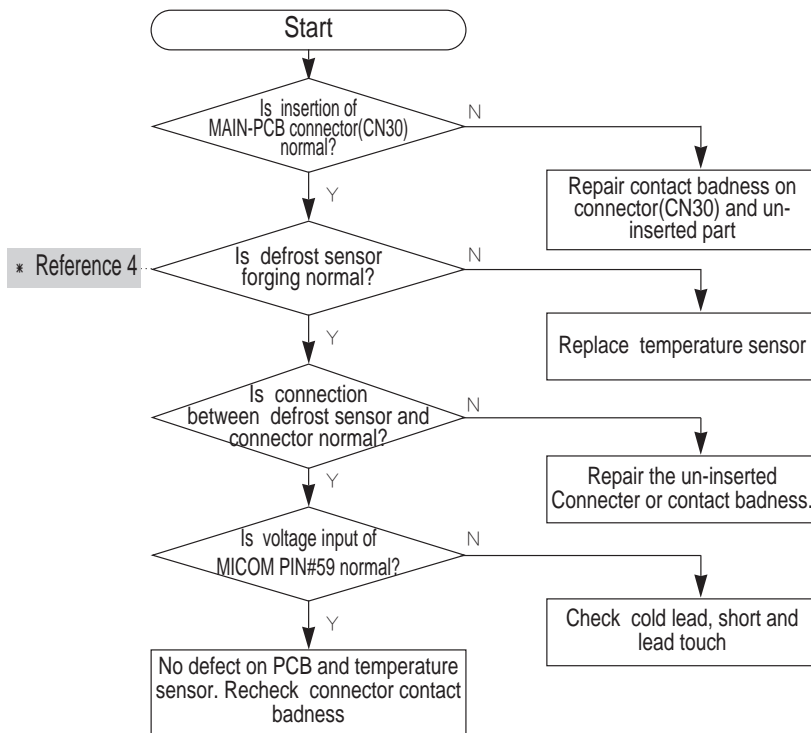

④ When abnormality on temperature sensor of freezer occurs

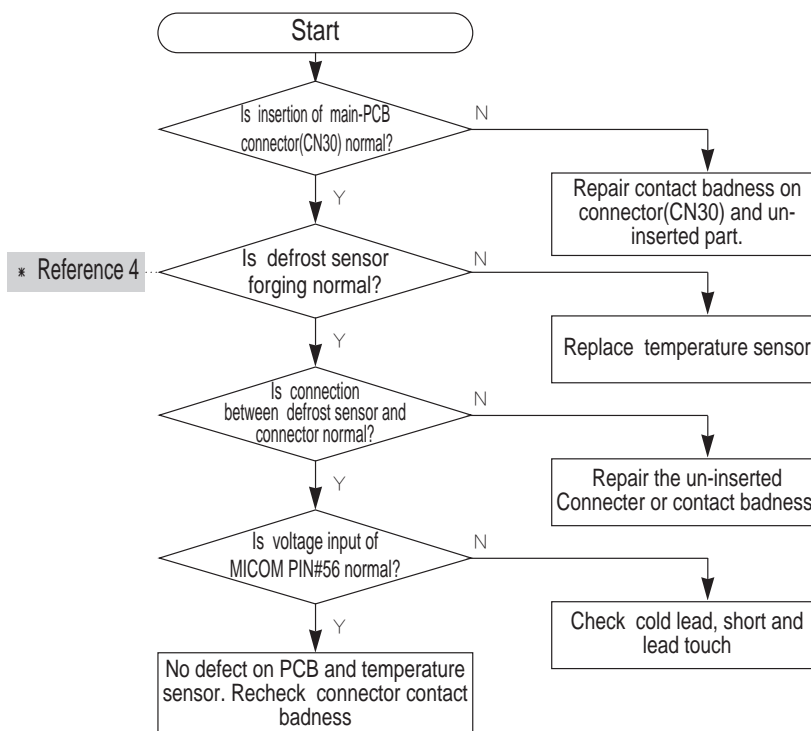

⑤ When abnormality on defrost sensor of freezer occurs

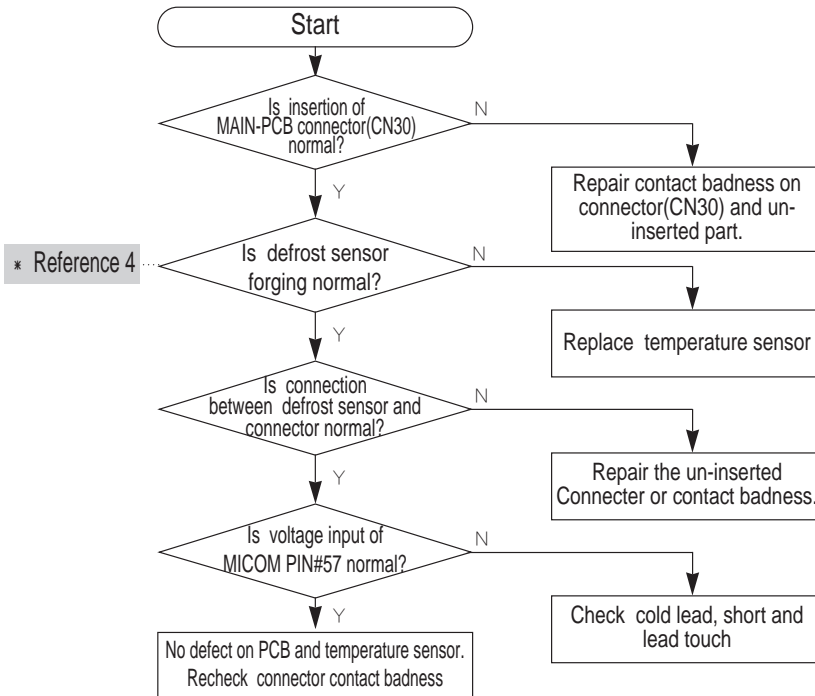

9-5) When alarm is continuously ringing

① When Ding-Dong sound continuously occurs

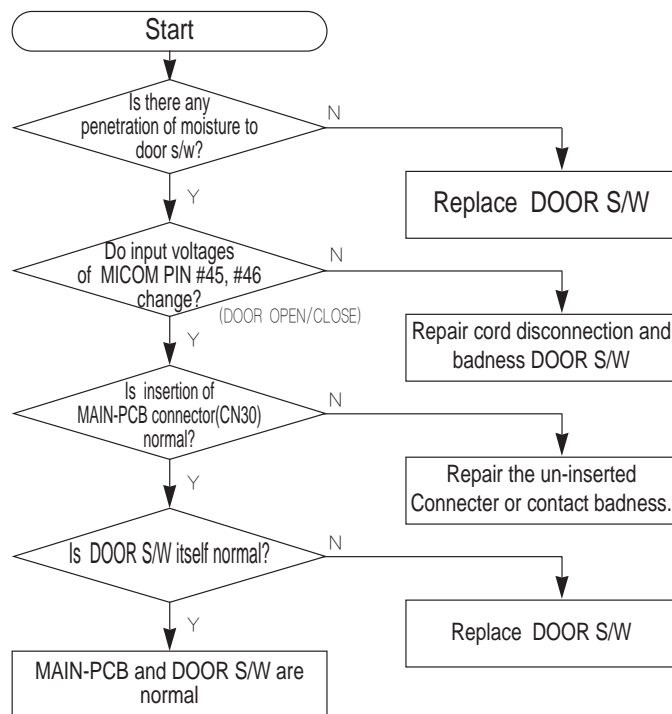

Reference

- Alarm for freezer/Refrigerator door open continues for 10sec. at the initial door open. After 2 min. of initial opening, it alarms for 10sec. by the 1min. cycle when door remains open (10 times of Ding-Dong sound).

② When “Beep-Beep” sound continuously occurs

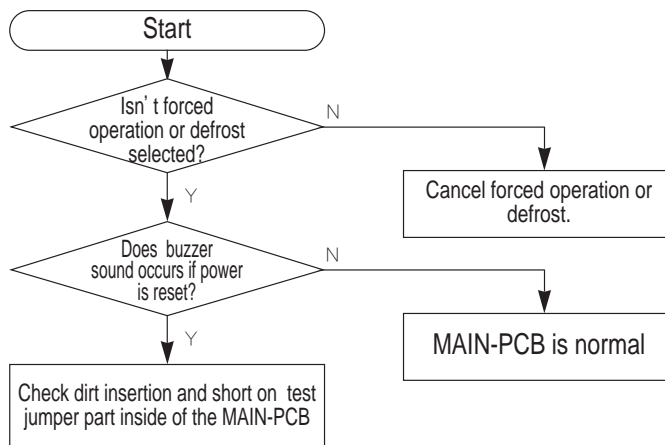

Reference

- Sound of “Beep-Beep” does not occur except abnormalities due to forced operation, defrost or self-diagnosis abnormality.
- In case of self-diagnosis abnormality, it is easy to check because it is indicated on panel-display. If “Beep-Beep” sound continues to ring though panel display is normal, it is considered that forced operation or defrost is selected.

③ In case PANEL-DISPLAY is not lit

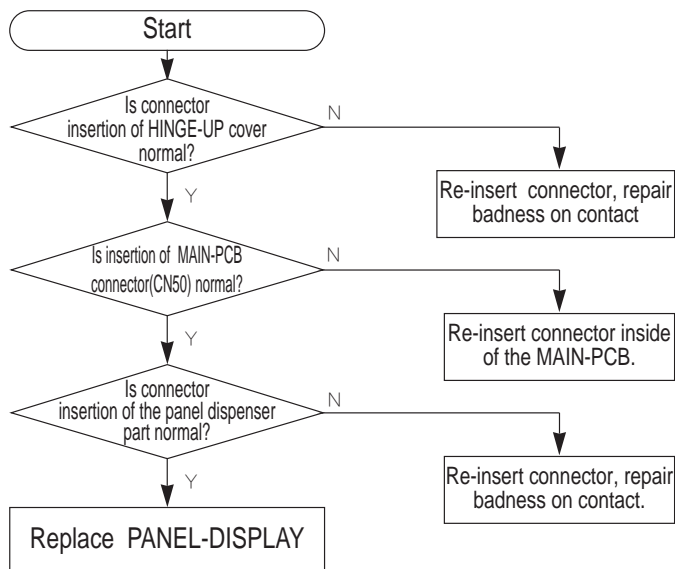

④ When key selection of PANEL-DISPLAY is not available

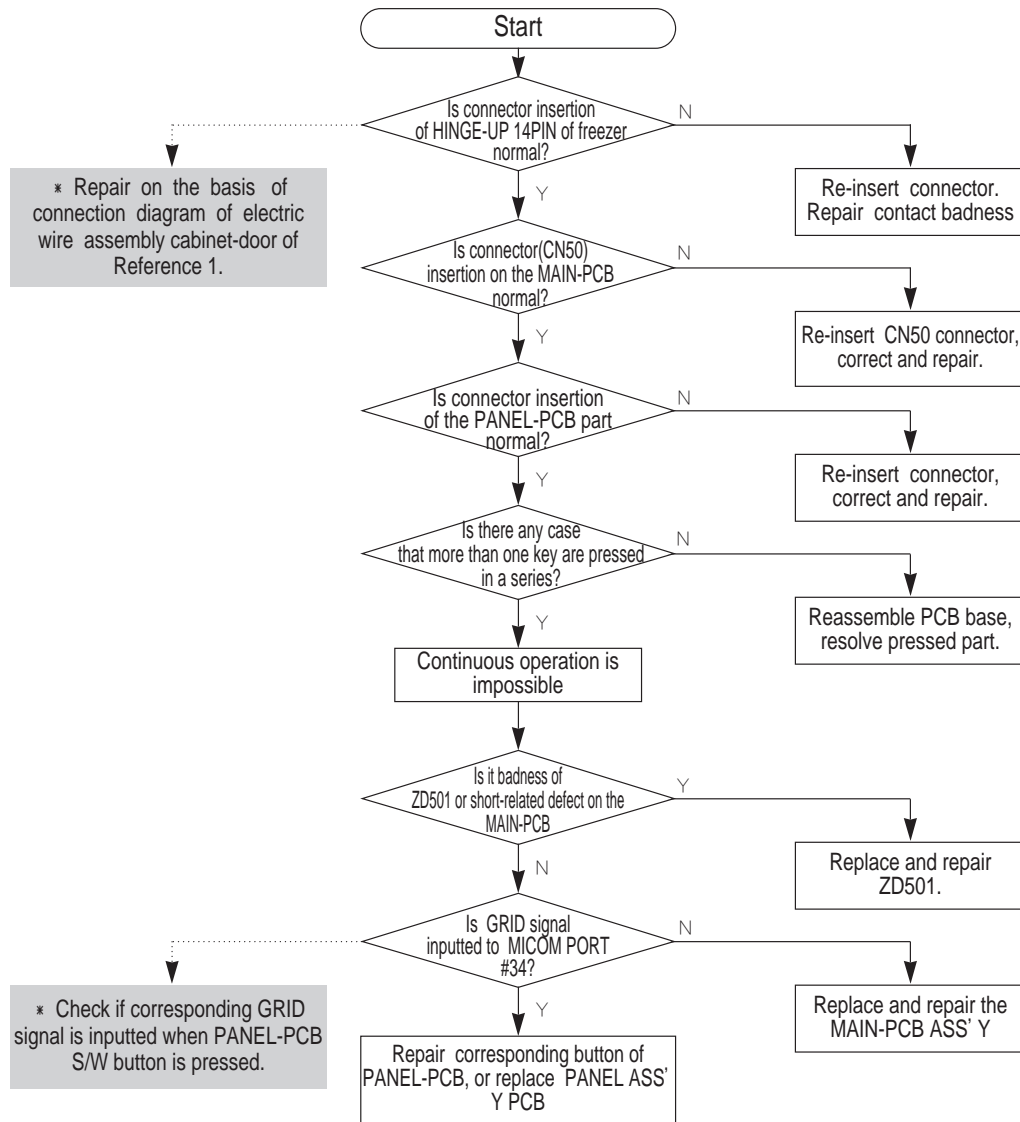

9-6) When FAN does not work

① When FAN of freezer(F-FAN) does not work (when COMP operates normally by temperature).

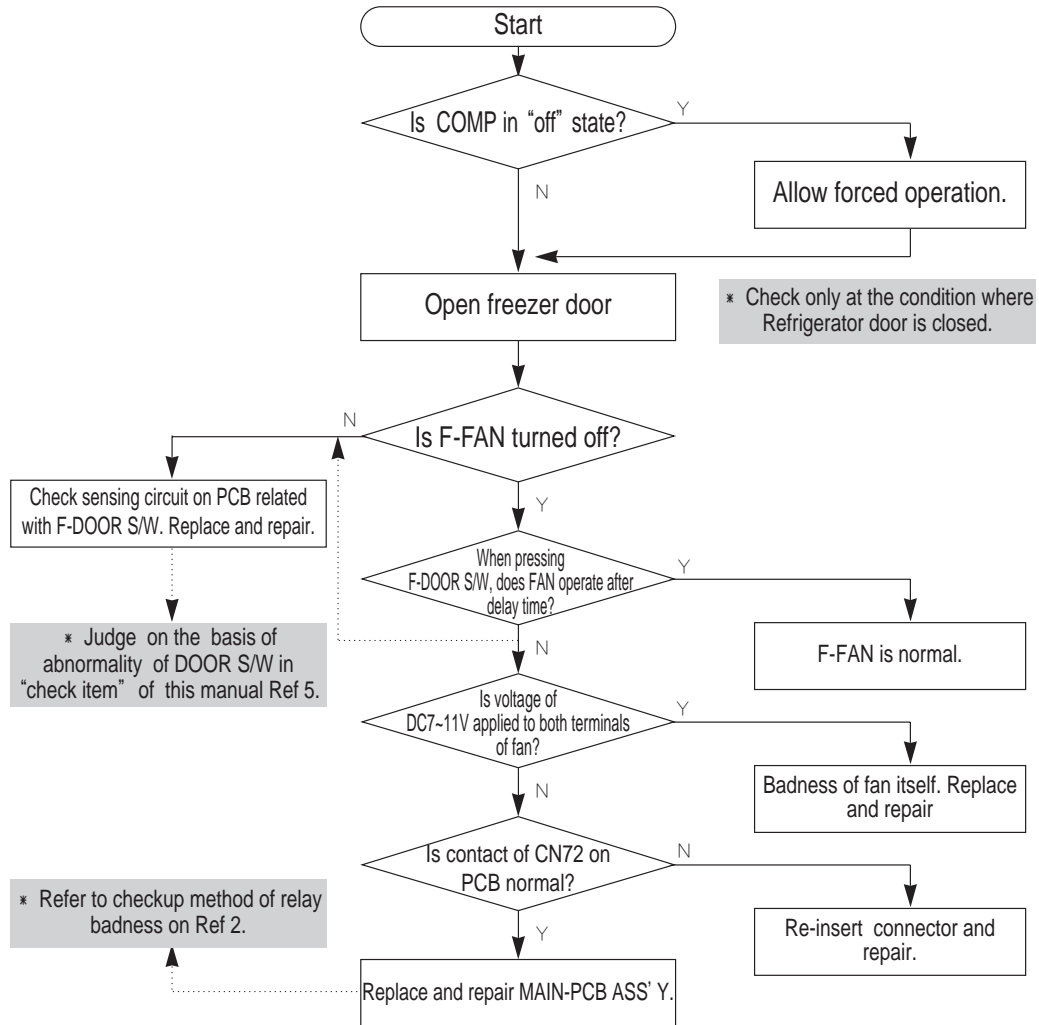

Reference

"Check cooling fan only at the condition of selecting forced operation necessarily."

1. When COMP is turned off, cooling fan of freezer(F-FAN), cooling fan of Refrigerator(R-FAN), COMP, and cooling fan of COMP mostly retains "off" state. However, in case of R-FAN, it can operate for some period of time by natural defrost function if COMP is turned off.(It operates depending on temperature condition of Refrigerator)
2. Evenat forced operation condition, R-FAN is not always turned on (including normal operation), and retains "off" state if temperature of Refrigerator room is reached the set temperature.
3. When the door of freezer and Refrigerator is closed after opening, each fan has its delay time. That is, fan stops immediately when door is opened during its operation, and operates again after delay of about 10sec. or 1min. (when outer temperature is over 35°C) when the door is closed.

② When Refrigerator fan (R-FAN) does not work (when temperature sensing function in Refrigerator room is normal).

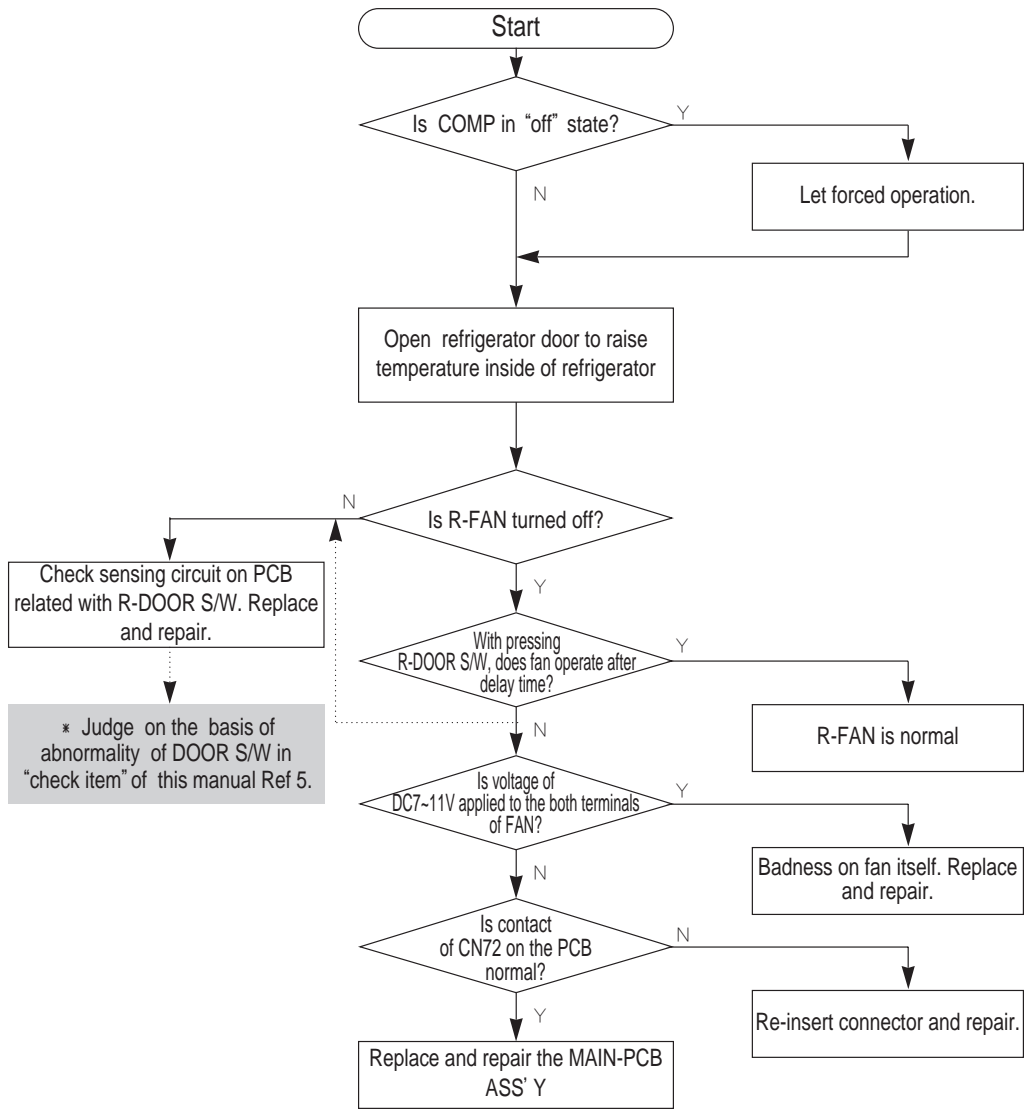

⚠ Caution

There exists the risk of electric shock when replacing the lamp inside of Refrigerator. Replace and repair at only "power off" state.

9-7) When lamp inside of Refrigerator is not lit.

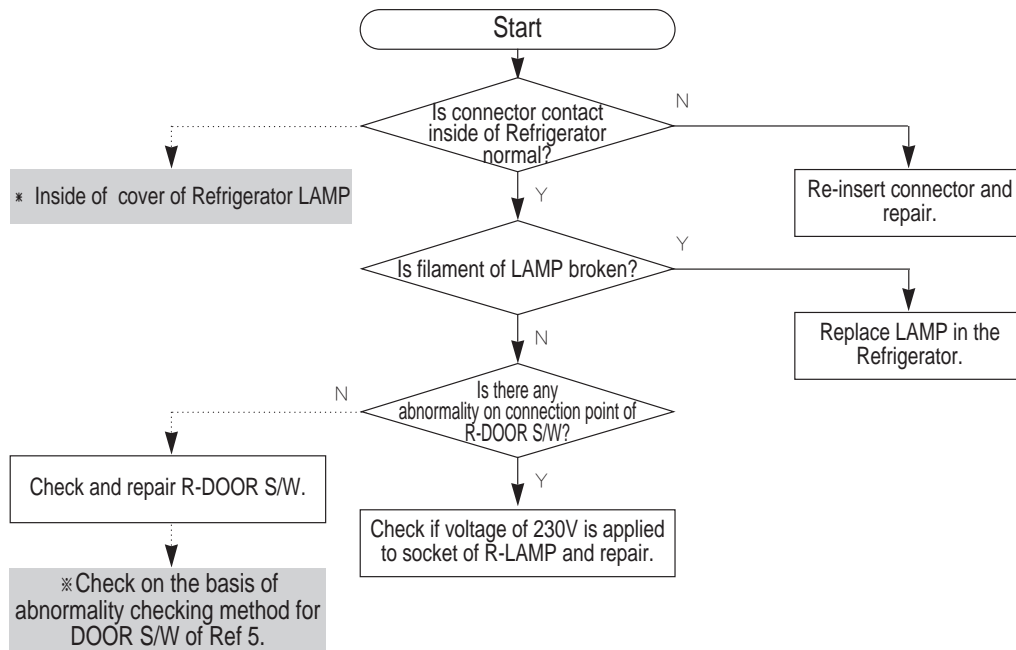

⚠ Caution

There exists the risk of electric shock when replacing the lamp inside of freezer room. Replace and repair at only "power off" state.

9-8) When lamp inside of freezer is not lit.

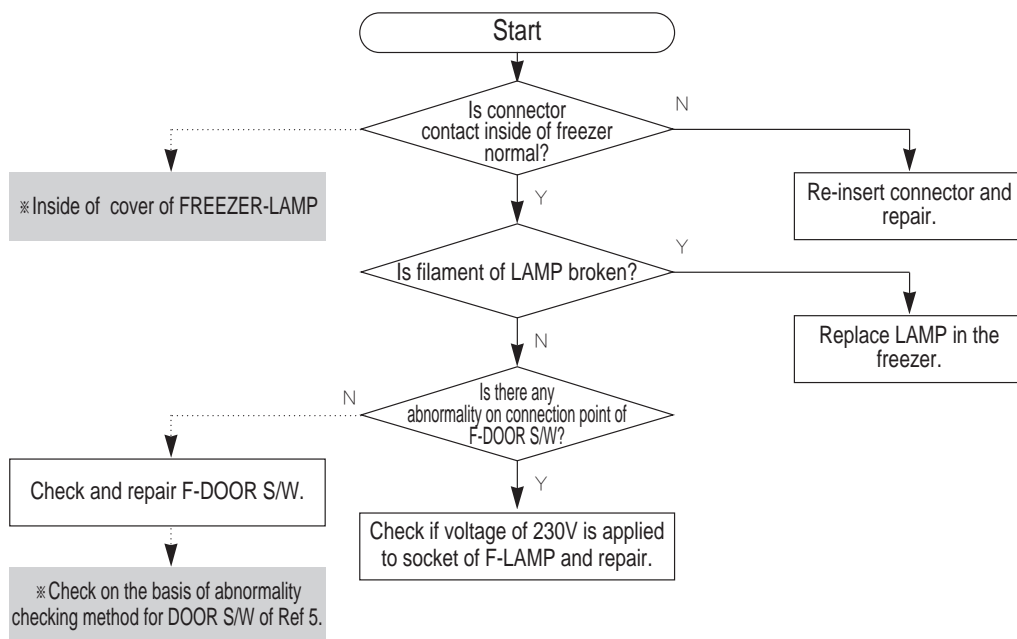

9-9) Abnormality diagnosis method for ICE-MAKER

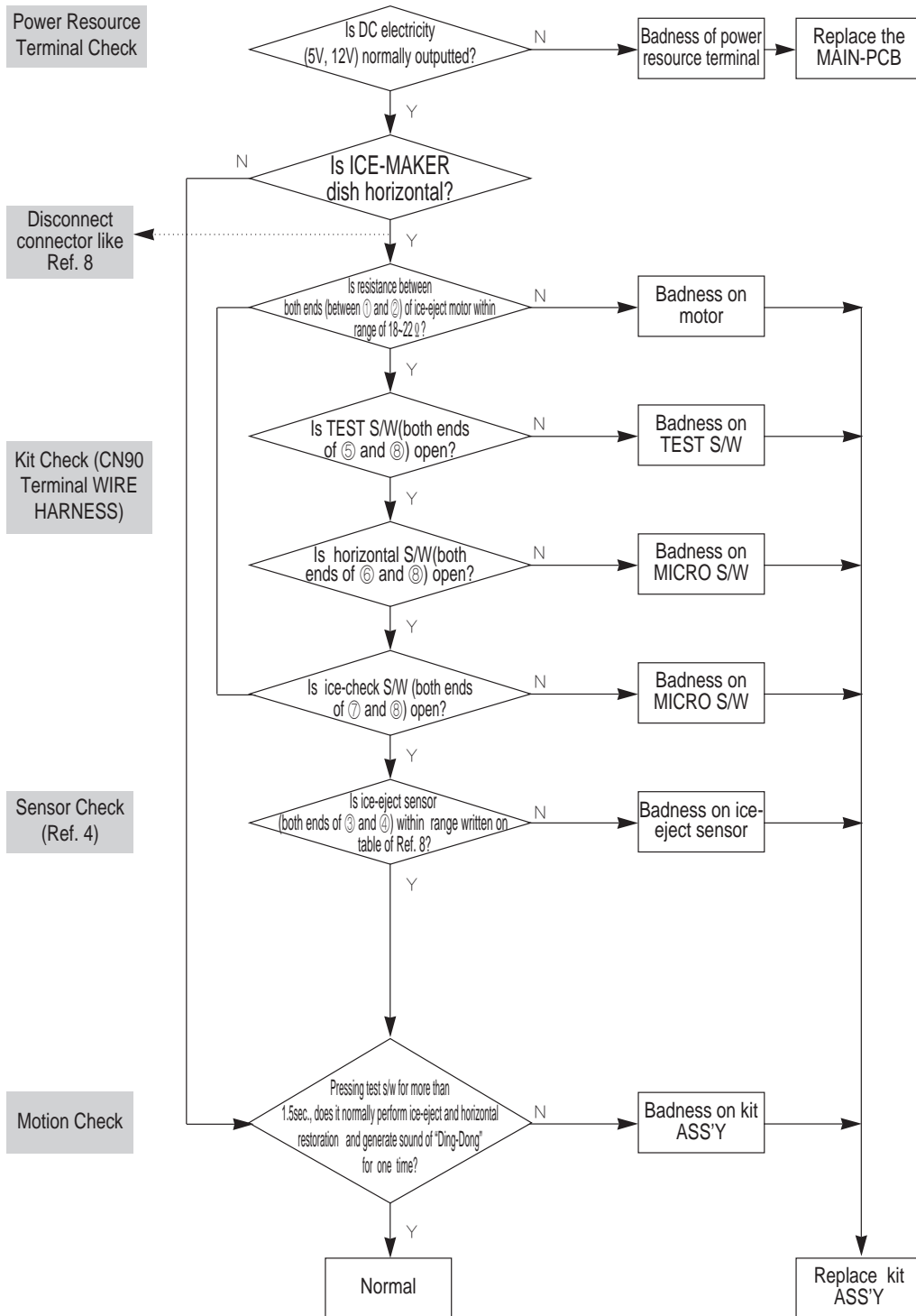

9-10) When cube and crushed ice are not normally operated.

① When cube ice does not come out when cold cube ice is selected.

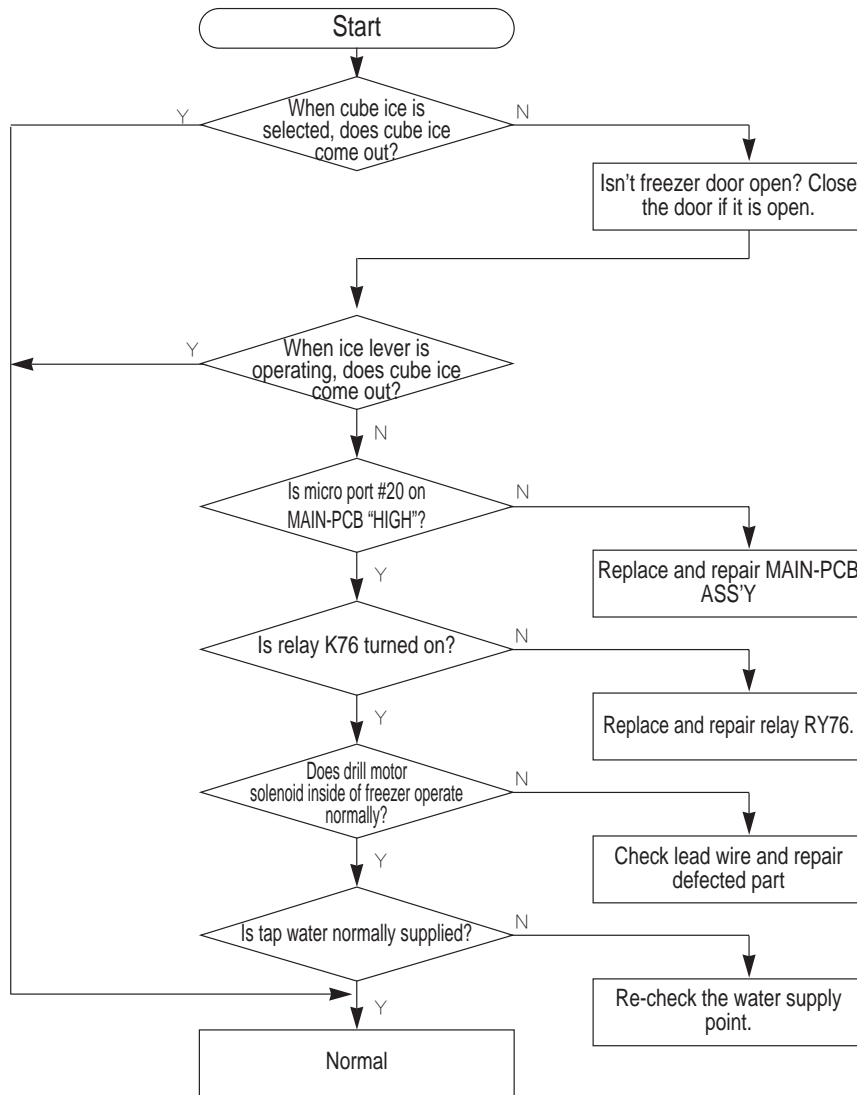

Reference

*When motion system is normal, however, if there is no ice in the ice container, ice does not come out. Please ensure whether there is ice in the ice container.

9-11) When solenoid which is cover ice-route delay device does not work

Pre-checkup

1. Check whether solenoid automatically operates for 0.3sec. regardless of open/close of cover ice-route 8 sec. after initial power on.
2. Check whether Hinge-up connector contact is normal.

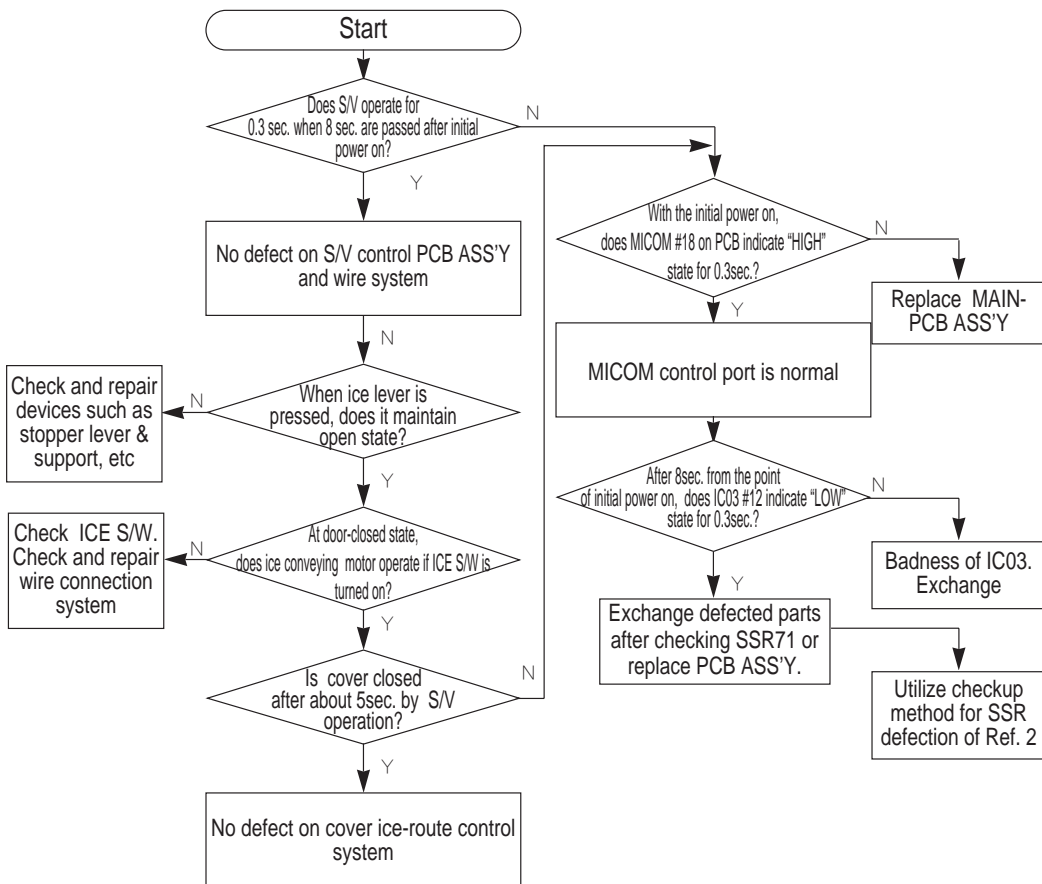

Reference

* S/V is abbreviation of Solenoid Valve

10. Operation Principle & Repair Method of ICE-MAKER

10-1) Operation Principle of ICE-MAKER

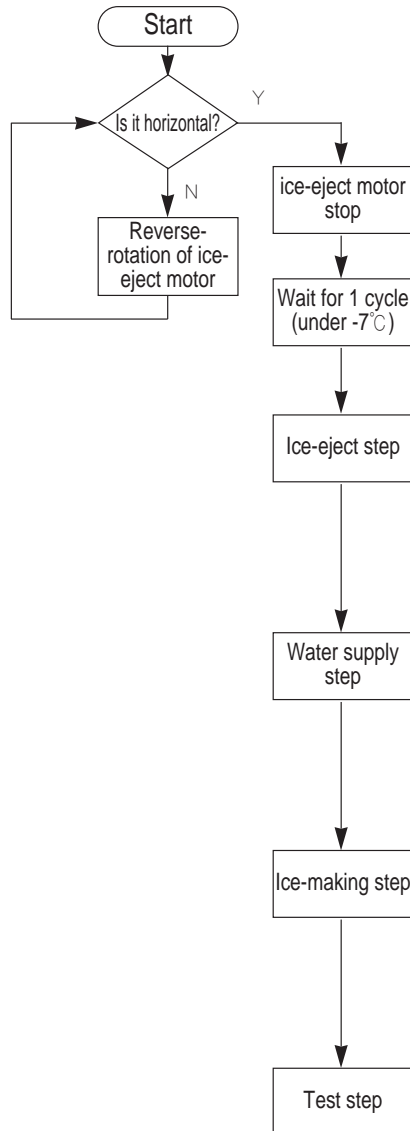

Performance of motion to retain horizontal level of ice-making dish for initial power apply or for restoration from stoppage of electric current.

Performance of ice-separation regardless of water supply to ice-making dish by waiting for 1 cycle.

After ice-making is finished, motion of ice-separation from ice on dish into storage container. Ice-separation is performed by checking the horizontal s/w, and the signal change of ice-inspection s/w and the changed time. They should be checked together in parallel.

After ice-making is finished, motion to supply ice-making water to ice-tray using water valve.

This step means the period from when water supply is finished to when it is judged that water turned into ice completely. This is judged by parallel checkup of temperature and time.

Function for cases which are needed for forced operation for the purpose of operation test, A/S, and cleaning. Ice-separation motion and water supply motion are conducted continually and this step should have priority than any other operations.

10-2) Ice-maker Test Function

5. Test Function

- It is function for the case which needs forced motion for the purpose of cleaning and so on at the time of operation test and A/S. This function is performed when the test s/w which is equipped with the body of automatic ice-maker itself, is pressed for more than 1.5 sec..
- 1) Test button does not go into test function during ice-eject, levelling for horizontal position and water supply. It operates in the horizontal state. It does not operate at the state where ice is fully filled. Only after ice full mode is cancelled and ice-check s/w is off, test function operates.
- 2) When test button is pressed in the horizontal state for more than 1.5sec., ice-eject motion starts immediately regardless of conditions of ice-making container. Therefore, if test function operates in the state where water does not freeze yet, water may be poured. So, care should be taken. After ice-eject motion, 1 cycle of water supply is carried out in horizontal levelling movement. Therefore, the problems of ice-eject movement, horizontal levelling movement, and water supply can be checked by the test button. At this time, when the test function operates normally, buzzer sound "Ding-Dong" occurs and starts water supply function. Hence, if buzzer sound "Ding-Dong" doesn't occur, it may be considered that there is some abnormality so that check and repair are indispensable.
- 3) When water supply is finished, it operates in normal cycle of ice-making → ice-eject → horizontal restoration → water supply in order.

<Case Where Test Function does not Work>

NO	Item	Measures to Operate	Remark
01	under operation	After finishing ice-eject, horizontal levelling and completion of water supply	
02	Ice is full	After removal of ice in ice container	Turn ice-check lever On → Off.

6. Function according to F-Room Door Open

- This is function to minimize noise occurrence by stopping operation basically when door F-room opens.
- 1) If F-room door opens while ice-eject or horizontal levelling is working, the function stops immediately at this point of time. When the door is closed, function operates normally.
- 2) In case water is being supplied, normal function is performed regardless of door open of F-room.
- 3) Accordingly, when F-room door is opened to check, if tray leans or its angle deviates from horizontal position, it is considered that it stops during ice-eject or horizontal levelling movement. It doesn't matter to judge it as a defect if it is not in horizontal position after more than 30sec. passes when F-room door is closed to keep horizontal state after water supply. In case it stops by F-room door open while it is operating, Test function doesn't work because it is actually working. So, after finishing water supply, test function operates.

10-3) ICE-MAKER Circuit Part (Limited to equipped model)

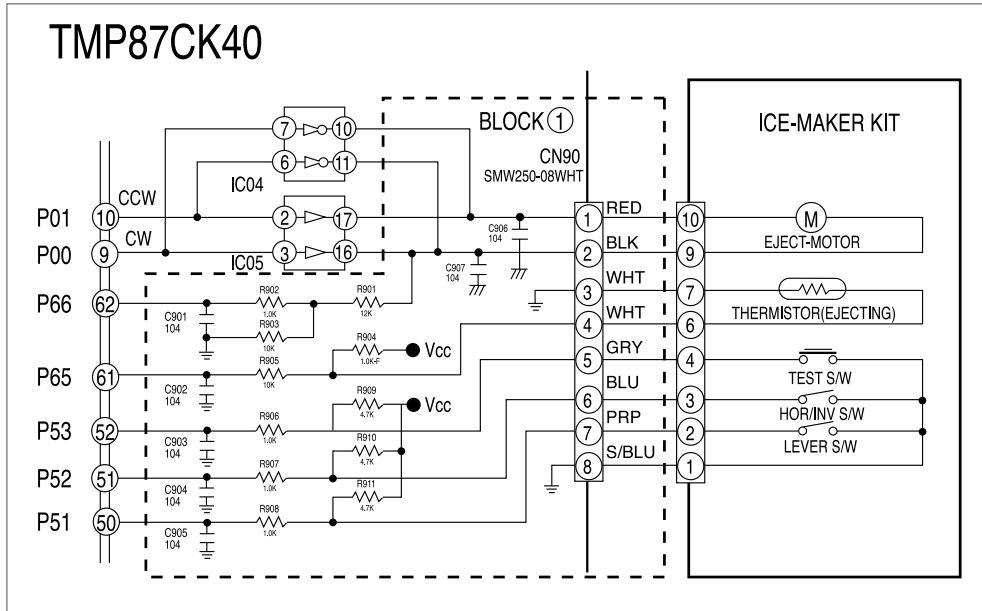

Above ice-maker circuit is one about a kit which is equipped at the freezer. Water supply to ice-making container is performed by operating AC solenoid which is located in the machine room through relay so that water is supplied by open/close time of valve. This circuit is H/W for embodiment of functions such as eject of ice-making container, horizontal levelling, ice-making temperature sensing and full-ice sensing. Temperature sensing part is identical to that of the main H/W, and horizontal(Hor/Inv) S/W, Ice-check(Lever) S/W and sensing circuit are identical to those of the main H/W. So, explanation about this is omitted here, and only ice-eject motor driving circuit part is explained.

When rotating motor in the counter-clockwise direction(CCW), if signal of Micom Port No #10 is outputted to High. When pressure of IC05 is applied, the voltage is applied of +12V by output of IC05 17, and the current is supplied to IC04 of ⑩ through motor. At this time, ⑥ terminal of IC04 is connected with CCW Port together so that output port of the corresponding IC04 ⑩ is turned on. Therefore, current flows to the ground and motor rotates inversely. When it moves to clockwise direction(CW), CW Port #9 is outputted by "HIGH". The functions of ice-eject and horizontal levelling are performed by the operation of IC Port through right direction rotation movement. For the points related with operation of above circuit, refer to the explanation of ice-maker function of our SVC Manual.

10-4) Designation of major components of Ice-Maker

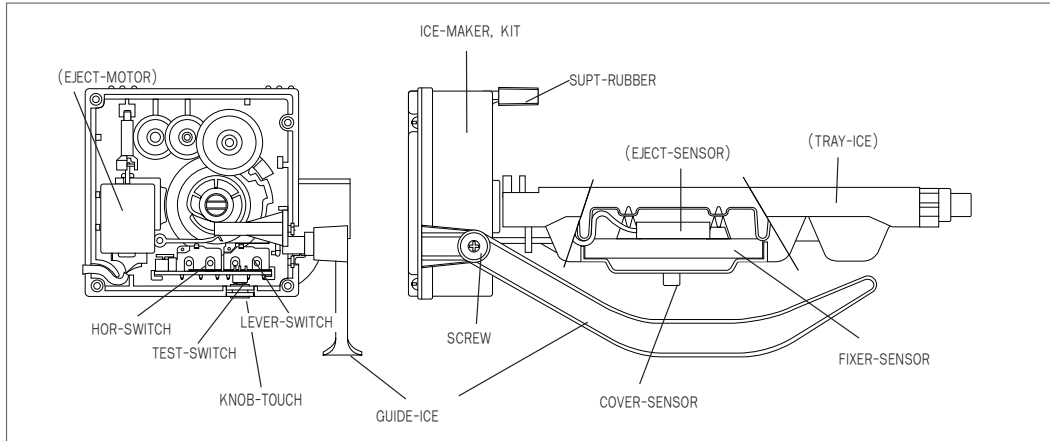

10-5) Operation of Ice-Maker

1. Connect the water-supply line to the supplying valve of the refrigerator to supply water.(See the water tube connection procedure)
2. Push bucket to the end so that guide-ice of ice-maker is not in contact with the end of bucket.(If the end of bucket is in contact with the guide-ice of the ice-maker, the ice-maker will determine that there is enough ice and does not make ice thereafter.)
3. With a newly installed refrigerator, allow about 6 hours for the refrigerator to make ice normally and discard the made ice several times to remove impurities.
4. To get enough ice stored in the storage bin, use the ice dispenser normally after operating the ice-maker for about 24 hours.

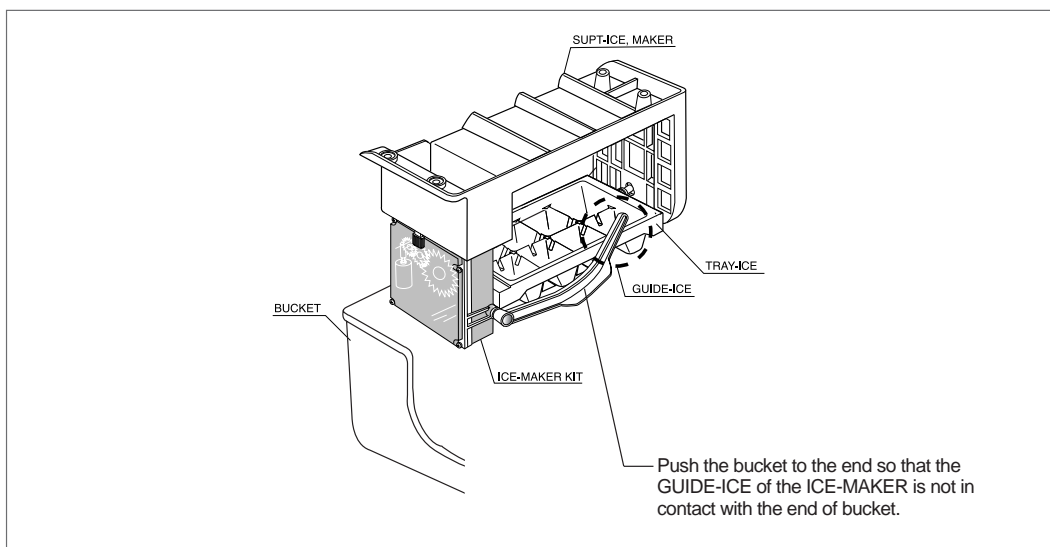

10-6) Disassembly of Ice Maker

1. Pull out the bucket from the freezer.
2. Disassemble the SUPT-ICE MAKER, which fixes the ice-maker, and the wire housing in the rear of the maker.
3. Disassemble by lifting the SUPT-ICE and FIXER-CASE in the front of the maker up (① direction) and pulling the ICE-MAKER KIT out to the front (② direction). (Do not disassemble each component of the ICE-MAKER KIT. Otherwise, the setting value may be changed.)

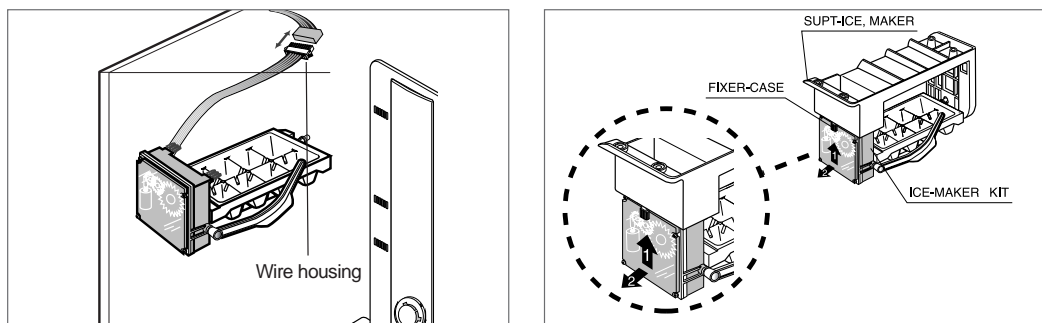

10-7) Assembly of Ice-Maker

1. Fit the rear rising of the ICE-MAKER KIT to the front slot of the TRAY ICE.
2. Lift FIXER-CASE at the front of the SUPT-ICE MAKER up. (① direction)
3. Place the top rising of the ICE-MAKER KIT to the slot of SUPT-ICE MAKER for insertion.
4. Push the front of the ICE-MAKER KIT while maintaining the position. (Be careful. If you overpush the ICE-MAKER KIT, the fixed rising of the SUPT-ICE MAKER may be damaged.)
5. When the front of the ICE-MAKER KIT is sagging, it means the assembly is not right. At that case, perform the assembly again.

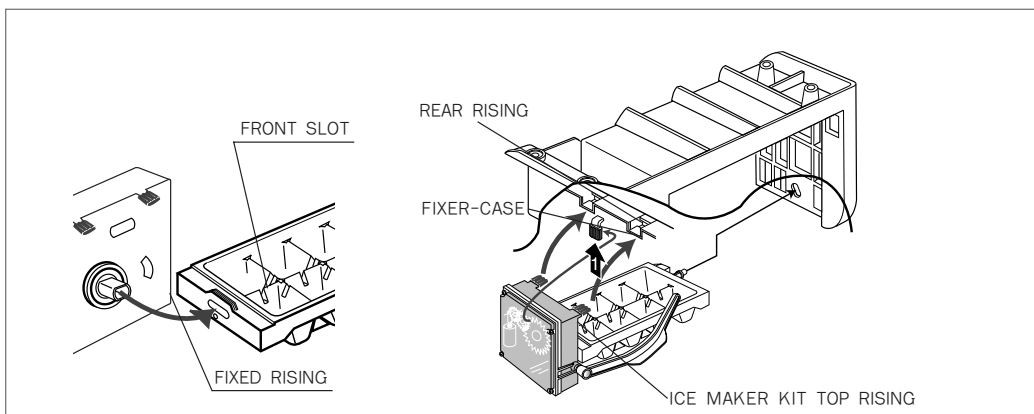

11. Reference

Reference No. 1) Electric Wire Assembly Cabinet-door Connection Drawing

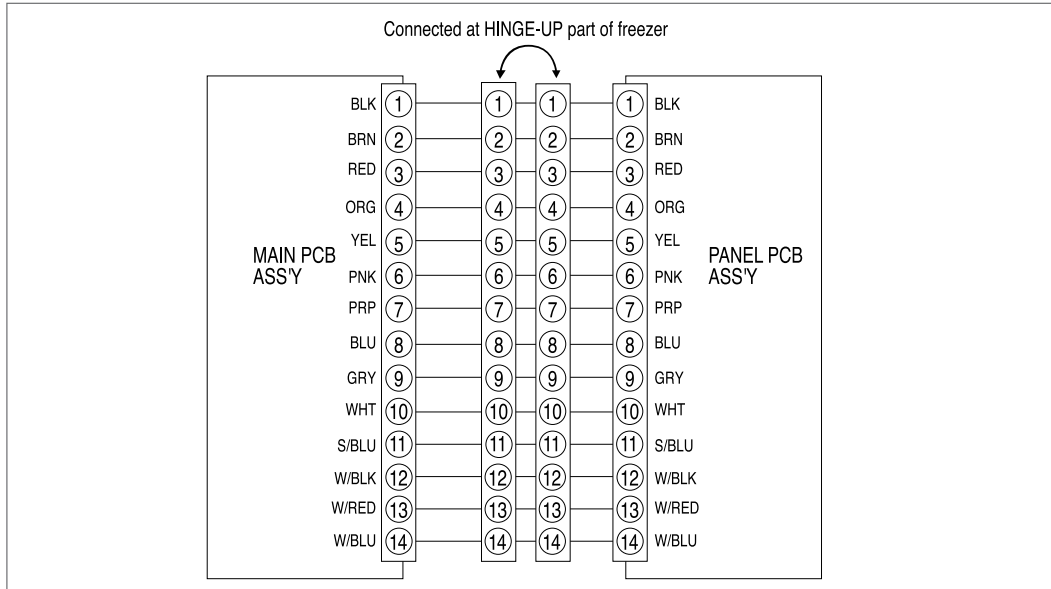

Reference No. 2) Test Method of Relay Defect

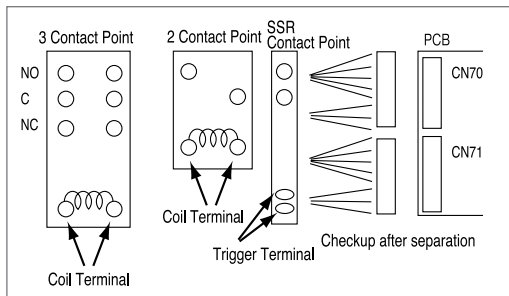

Note) NC→Normal Close(C Terminal and Common ON Terminal)
 NO→Normal Open(C Terminal and Common OPEN Terminal)
 C →Common Terminal

First, separate housing which is connected to load connection part(Main PCB CN70~CN71). Check the following items (Judge by voltage and resistance value).

1. Judge whether relay moves or not by measuring voltage of both coil terminals.
2. Judge whether SSR moves or not by measuring voltage of two trigger terminals.
3. Load contact point of two terminals are measured by resistance value. Whether there is fault or not is judged by comparing with voltage conditions of coil and trigger.

Contact Point Division	Coil and Trigger Two Terminal Voltage	Two Terminal	Contact Point
3 Contact Point Relay	DC about 12V (Movement Condition)	Between C and NO	0 Ω (SHORT)→Normal
		Between C and NC	∞ Ω (OPEN)→Normal
	DC About 0V (Stop Condition)	Between C and NO	∞ Ω (OPEN)→Normal
		Between C and NC	0 Ω (SHORT)→Normal
2 Contact Point Relay	DC About 12V(Load Movement condition)	Contact Points Between Two terminals	0 Ω (SHORT)→Normal
	DC About 12V(Load Stop Condition)	Contact Points Between Two terminals	∞ Ω (OPEN)→Normal
SSR	DC About 12V(Load Movement condition)	Contact Points Between Two terminals	About 4kΩ ~5kΩ (SHORT)→Normal
	DC About 12V(Load Stop Condition)	Contact Points Between Two terminals	∞ Ω (OPEN)→Normal

Note) SSR: Solid State Relay (No Contact Point Electric Type Relay)

Reference No. 3) Load Defect Checkup

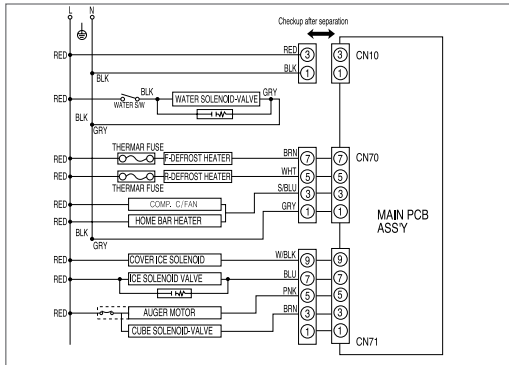

After separating power cord from power source plug socket, separate connectors CN10, 70, and 71 of the main PCB, and check the following items.

1. Measure load terminal and resistance value between terminals like the following to check whether there may exist defects of load and electric wire connection.

Load	Measure	Terminal	Fault Item	Remark
F-Defrost Heater	Between CN70 ⑦ and CN10 ③	0 Ω	Badness of temperature, fuse, heater, electric wire short-circuit	
		∞ Ω	Badness of temperature, fuse, heater, and electric wire disconnection	
R-Defrost Heater	Between CN71 ⑤ and CN10 ③	0 Ω	Badness of motor coil and wire short-circuit	
		∞ Ω	Badness of motor coil and wire short-circuit	
Ice Solenoid (Machine Room)	Between CN71 ⑦ and CN10 ③	0 Ω	Badness of coil and wire short-circuit	I/M Application Model
		∞ Ω	Badness of coil and wire short-circuit	
Cube Solenoid (F-Room Inside)	Between CN71 ⑦ and CN10 ③	0 Ω	Badness of coil and wire short-circuit	I/M Application Model
		∞ Ω	Badness of coil and wire short-circuit	
Cover Solenoid (F-Door)	Between CN71 ⑨ and CN10 ③	0 Ω	Badness of coil and wire short-circuit	I/M Application Model
		∞ Ω	Badness of coil and wire short-circuit	
AUGER MOTOR	Between CN71 ⑤ and CN10 ③	0 Ω	Badness of coil and wire short-circuit	I/M Application Model
		∞ Ω	Badness of coil and wire short-circuit	
HOME-BAR HEATER	Check resistance of the red and sky blue line of R-door side	0 Ω	Badness of heater wire short-circuit	H/B Application Model(check connection/terminal only after separation)
		∞ Ω	Badness of heater wire short-circuit	

Note) COMP parts can be changed by Capacitor, PTC, and Over Load Protector. Therefore, they are checked by existence of movement.

Reference No. 4) Fault Check Method of Various Sensors

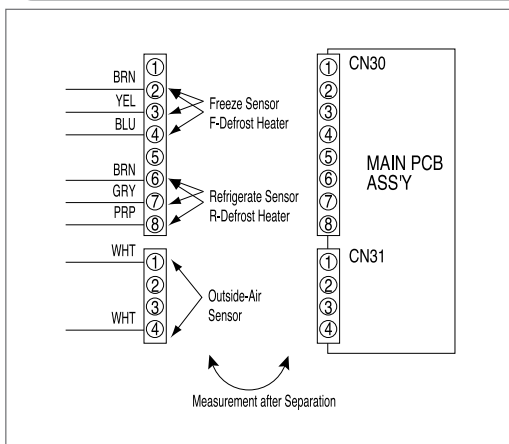

After separating connector from the MAIN-PCB, measure resistance of sensor forging, and judge fault existence.

1. Freezer Sensor CN 30, measure resistance value between and
 2. Refrigerator Sensor CN30, measure resistance value between and
 3. F-Defrost Sensor CN30, measure resistance value between and
 4. R-Defrost Sensor CN30, measure resistance value between and
 5. Outside Air Sensor CN31, measure resistance value between and
 6. Compare above measurement value with temperature of location of each sensor. Also compare with sensor resistance and voltage conversion table about temperature of Ref. 8 of this manual. And judge whether there is any defect.
- ※ At this time, when measuring ∞ Ω or 0 Ω, check wire assembly condition.

Reference No. 5) Check Door S/W Fault & Ice Lever S/W Check Method

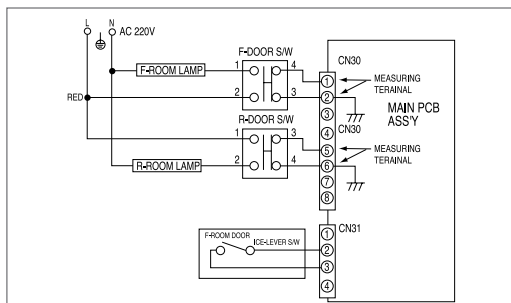

Check in state that power is applied. Door S/W is 2 contact-point circuit; one contact-point senses door open/close with DC 5V on PCB, and the other contact-point lets refrigerator inside lamp fluorescent On/Off.

(R-Room Lamp Part)

1. When refrigerator door is opened, check whether lamp is lit up or not. If it is normal, check whether lamp lights out or not when pressing DOOR S/W in the state that R-DOOR is open. If any faults are found, check DOOR S/W of R-ROOM door.

(MAIN-PCB Sensing Part for R-ROOM Door Open)

1. Check voltage by applying "+" terminal to CN30 and "-" terminal to .
2. When R-ROOM door is opened, if about DC 5V is measured, it is normal.
3. When R-ROOM door is closed, if about DC 0V is measured, it is normal. If any faults are found, check DOOR S/W and wire connection system.

(F-Room Lamp Part)

1. When freezer door is opened, check whether lamp is lit up or not. If it is normal, check whether lamp lights out or not when pressing door S/W in the state that F-DOOR is open. If any faults are found, check door S/W of F-ROOM door.

(MAIN-PCB Sensing Part for F-ROOM Door Open)

1. Check voltage by applying "+" terminal to CN30 and "-" terminal to .
2. When F-ROOM door is opened, if about DC 5V is measured, it is normal.
3. When F-ROOM door is closed, if about DC 0V is measured, it is normal. If any faults are found, check DOOR S/W and wire connection system.

(Ice Eject Lever)

1. In case ice is not ejected though ice eject lever which is installed at the front part of freezer, check like the following.
2. First, check fault existence of F-ROOM DOOR S/W. If no defect is found, separate CN31 connector on the MAIN-PCB. Apply "+" terminal to and "-" terminal to, and check resistance. Check it becomes 0 Ω when ICE LEVER S/W was pressed. When it is always regardless of ON/Off of S/W, check wire system and connection system.

Reference No. 6) Resistance of Sensor about Temp. & Voltage Conversion Table

Voltage inputted to Micom Port differs according to H/W structure. This specification is standardized one by voltage which is applied at the time when 10k Ω -F grade of partial pressure resistance is used.
 Corresponding Micom Port Voltage Specifications when Sensor is Open : DC about 5V(Vcc Level)
 Corresponding MicomPort Voltage Specifications when Sensor Short : DC about 0V(Ground Level)

Temperature(°C)	Resistance (K Ω)	Voltage (V)	Temperature(°C)	Resistance (K Ω)	Voltage (V)	Temperature(°C)	Resistance (K Ω)	Voltage (V)
-35	68.648	4.364	-12	21.814	3.428	11	8.345	2.274
-34	65.011	4.333	-11	20.848	3.397	12	8.032	2.227
-33	61.595	4.301	-10	19.932	3.329	13	7.732	2.180
-32	58.384	4.268	-09	19.062	3.279	14	7.446	2.134
-31	55.366	4.235	-08	18.237	3.229	15	7.172	2.088
-30	52.526	4.2	-07	17.453	3.178	16	6.910	2.043
-29	49.854	4.164	-06	16.709	3.127	17	6.659	1.998
-28	47.337	4.127	-05	16.001	3.076	18	6.420	1.954
-27	44.967	4.09	-04	15.328	3.025	19	6.190	1.911
-26	42.733	4.051	-03	14.688	2.974	20	5.970	1.869
-25	40.626	4.012	-02	14.080	2.923	21	5.759	1.827
-24	38.640	3.972	-01	14.501	2.872	22	5.557	1.786
-23	36.765	3.93	00	12.949	2.821	23	5.363	1.745
-22	34.995	3.888	01	12.424	2.77	24	5.178	1.705
-21	33.323	3.845	02	11.924	2.719	25	5.000	1.666
-20	31.743	3.802	03	11.447	2.668	26	4.829	1.628
-19	30.250	3.757	04	10.993	2.618	27	4.665	1.590
-18	28.838	3.712	05	10.559	2.567	28	4.508	1.553
-17	27.502	3.666	06	10.146	2.518	29	4.357	1.517
-16	26.237	3.62	07	9.752	2.468	30	4.212	1.481
-15	25.040	3.573	08	9.375	2.419	31	4.072	1.446
-14	23.906	3.525	09	9.016	2.37	32	3.938	1.412
-13	22.832	3.477	10	8.673	2.322	33	3.810	1.379

Reference No. 7) Forced Operation and Defrost Input Method

(Forced Operation)

It is a function to operate COMP and F-fan immediately regardless of freezer temperature.

1. When pressing Quick Freeze S/W and Cold room Temperature Control S/W on the Panel together more than 8sec., all displays become Off. And, four temperature corresponding S/W(Quick Freeze, Vacation, Freezer Temperature Control, Refrigerator Temperature Control) operate by test button.
2. In the above state, when pressing any one among four control S/W once, forced operation starts.

(Forced Defrost)

It is a function to make R defrost or R and F defrost at a time regardless of defrost time.

1. In state of forced driving, when pressing the S/W once, R room alone is defrosted. And, if pressing it once more, simultaneous defrost of R and F is performed.: Buzzer sound occurs at forced defrost, too.
2. After making Power Off and let it be On again, cancellation is made.

Reference No. 8) Circuit Par Service Material List

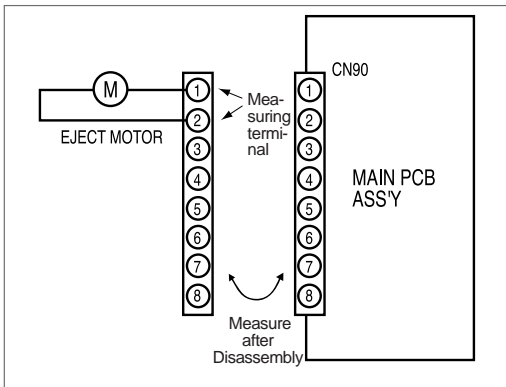

<Eject Motor Check>

Check Method for Motor when EJECT MOTOR does not operate.

1. Disconnect CN90 from MAIN PCB.
2. Check the resistance value between ① and ② of CN90, connector, of Load Terminals.
3. If the resistance value is between 18 and 22 Ω , it is normal.
4. If the value is 0 Ω , it is SHORT fault. Check the wire connection state and Motor.
5. If the value is $\infty \Omega$, it is OPEN type and check the wire connection line.

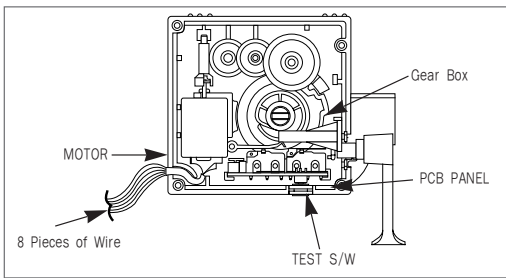

<TEST Operation method>

This is for check whether the Motor operates normally and whether water is normally supplied.

1. When S/W in the KIT inside the Freezer is pushed, TEST operation will starts. More detailed instruction of Test operation, refer to the section of the ICE-MAKER TEST functions.

Reference No. 9) Circuit Part Service Material List

NO	CODE-NO	Product Name	Specification	Quantity	Remark
1	DA41-00024A	MAIN PCB ASS' Y	-	1	Basic Type
2	DA41-00027A		-	1	Ice & Water Disp Type
3	DA41-00020A	PANEL PCB ASS' Y	-	1	Basic Type
4	DA41-00020B		-	1	Ice & Water Disp Type
5	DA32-10105H	F, R ROOM SENSOR	502AT(100mm)	2	Common Use
6	DA32-10109Q	Outside Air Sensor	502AT(2,615mm)	1	Common Use
7	DA32-10109R	F-EVA. SENSOR	502AT(540mm)	1	Common Use
8	DA32-10109N	R-EVA. SENSOR	502AT(370mm)	1	Common Use
9	DA27-00002A	NOISE FILTER	CAN TYPE	1	Common Use
10	3301-000016	FERRITE CORE	BNF-18	1	Common Use

12. Disassembly Method of Freezer & Refrigerator

12-1) Disassembly Method of Freezer & Refrigerator Accessories

Sensor Cover

- After rotating cover "B" in the left direction and pulling it out, release screw with a (+)screwdriver.

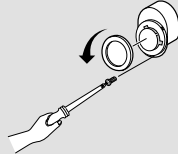

Dispenser (SR-S2028, S2029, S2228, S2229)

- Dispenser(SR-S2028, S2029, S2228, S2229)lift the front cover and take out.

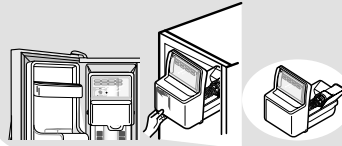

Deodorizer Cover

- Press the jaw which is placed at the outside of deodorizer cover and pull out.

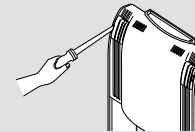

Dry Room Cover

- After deviating from the jaw of cover by pressing it to the left, lift it upward and pull out.

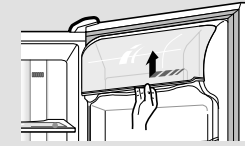

Interior Lamp of Freezer (Basic)

- Deviate the jaw of interior lamp cover by pressing it in the arrow direction of with (-) screwdriver or similar tools.
- Turn the interior lamp in the left direction and pull it out.

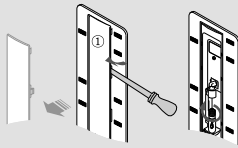

Interior Lamp of Freezer (Dispenser)

- Unscrew the lamp with (+) driver and deviate the projection jaw.
- Replace the lamp in inner refrigerator room by disassembling Lamp-Cover.

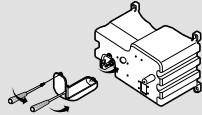

Ice Storage Container & Ice Container

(SR-S ,S ,S ,S)

- After pulling the ice storage container forward, take it out. Then, pull ice container forward and take it out.

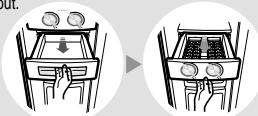

COVER Leg front

- After opening doors of freezer and refrigerator, disassemble three screws on leg cover, and pull it out.
- When inserting leg cover, set it to three grooves and assemble screws.

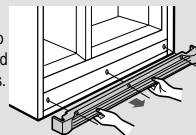

Shelf

- Draw the shelf. Lift the shelf at the point where it is caught, and pull it out.

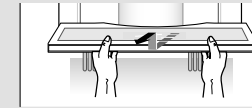

Multi-purpose Compartment

- Grab multi-purpose compartment with two hands and lift up. Take it out.

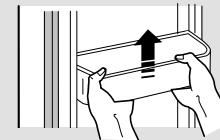

Vegetable and Fruit Box

- Pull vegetable and fruit box forward with grabbing handle of it. Lift it up a little at the point of jaw, and take it out.()
- Pull forward and take out the cover of vegetable and fruit box.()

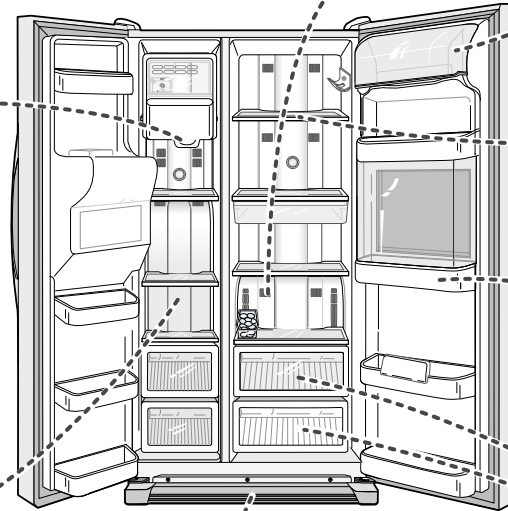

12-2) Disassembly of Cooler Part of Freezer Room

1. Using (-)screwdriver or similar tools, disassemble the cover of inside lamp.
2. Separate cover-sensor B by turning to the left, and disassemble screw of cover-sensor A using (+) screwdriver.
3. After disassembling the housing of temperature sensor and inside lamp, remove the fixed screws (5 spots). And, pull forward the lower part of cover-multi with hands.
4. Grip the upper part of the front cover of cooler. Pull it carefully in the arrow direction. Deviate the jaw part of cover and pull out.
5. Disassemble motor and heater housing from the wire terminal which is assembled at the inside of upper side.

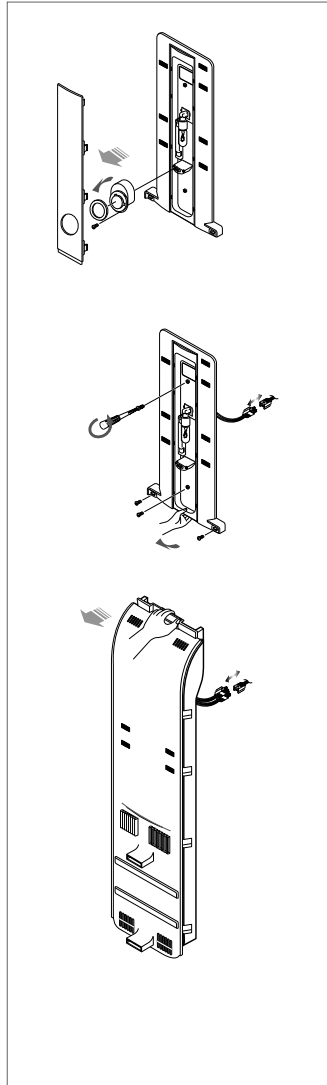

12-3) Disassembly of Cooler Part of Refrigerator Room

1. Using (-)screwdriver or similar tools, disassemble the cover of inside lamp.
2. Separate cover-sensor B by turning to the left, and disassemble screw of cover-sensor A using (+) screwdriver.
3. After disassembling the housing of temperature sensor and inside lamp, remove the fixed screws (5 spots). And, pull forward the lower part of cover-multi with hands.
4. Deviate the jaw part of deodorizer cover (left - right) and disassemble it.
5. Remove the fixed screws (4 spots) of the front cover of cooler using (+) screwdriver. Deviate the jaw part of cover by pulling it carefully in the arrow direction.
6. Disassemble motor and heater housing from the wire terminal which is assembled at the inside of upper side.

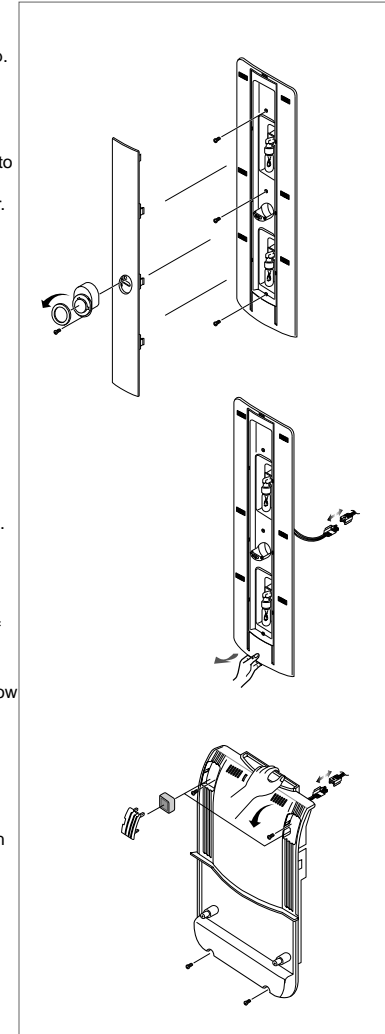

12-4) Temperature Control Part

SR-S2026, S2027, S2226, S2227
Basic & with Home-Bar type

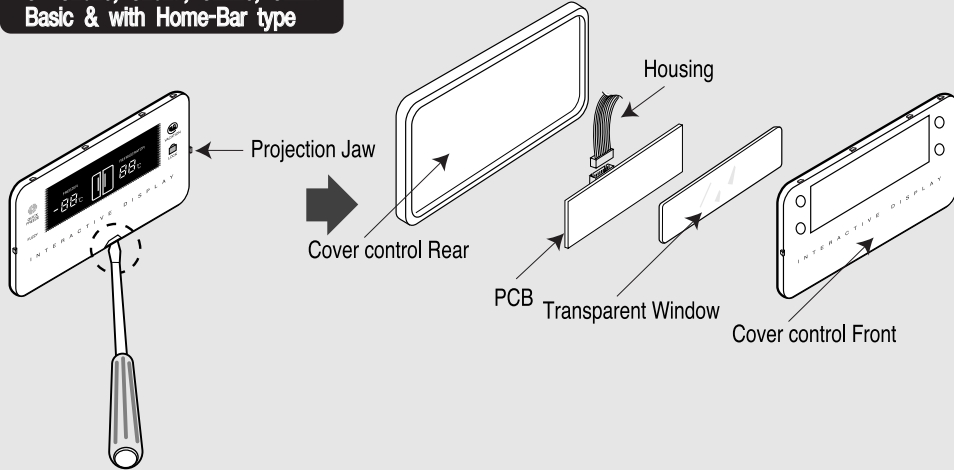

SR-S2028, S2029, S2228, S2229
Dispenser & with Home-Bar type

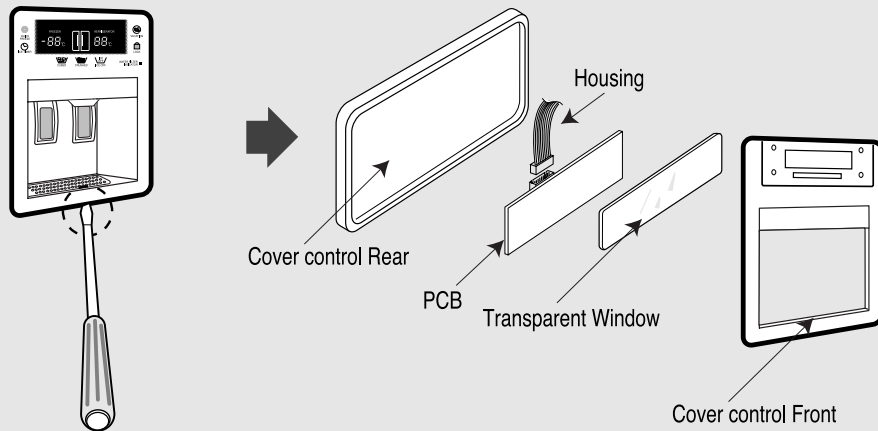

- Disassemble the projection jaw using a \ominus screwdriver to the groove of lower part of Control Front Cover.

- Disassemble wire housing connected to PCB. Disassemble PCB plate at the projection jaw.
- Assembly is done by reverse order of disassembly.

**SR-S2028, S2029, S2228, S2229
Dispenser & with Home-Bar type**

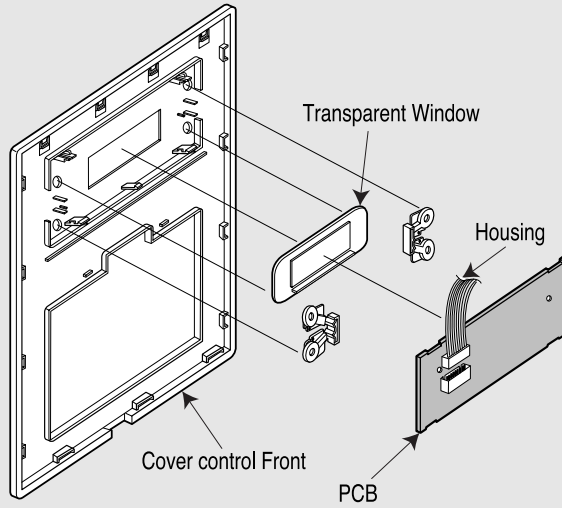
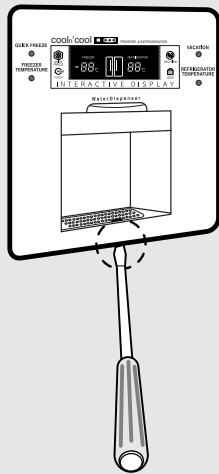

- Disassemble the projection jaw using a \ominus screwdriver to the groove of lower part of Control Front Cover.

- Disassemble wire housing connected to PCB. Disassemble PCB plate at the projection jaw.
- Assembly is done by reverse order of disassembly.

13. Method of HINGE-UP Assembly & Disassembly

1. HINGE-UP ASS'Y Structure

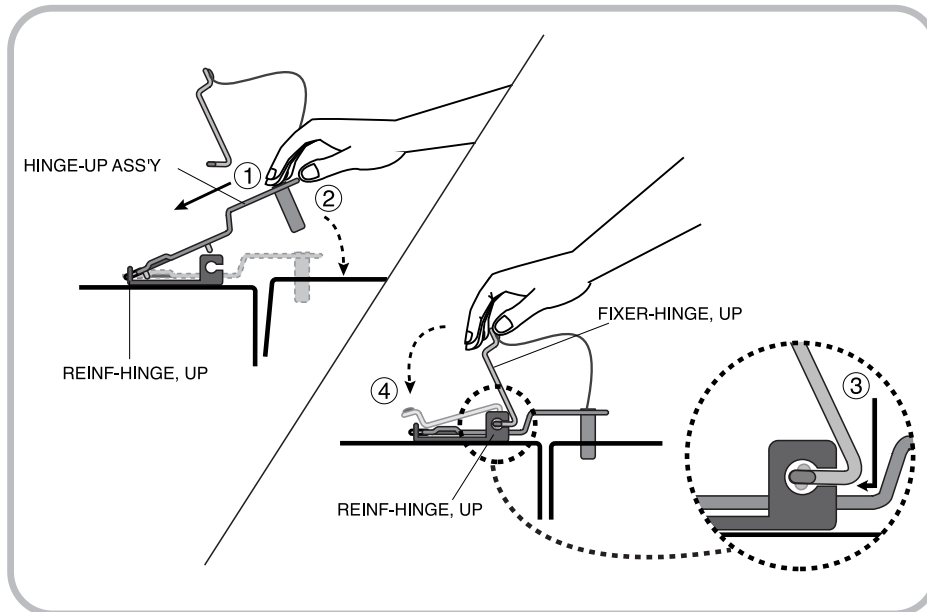
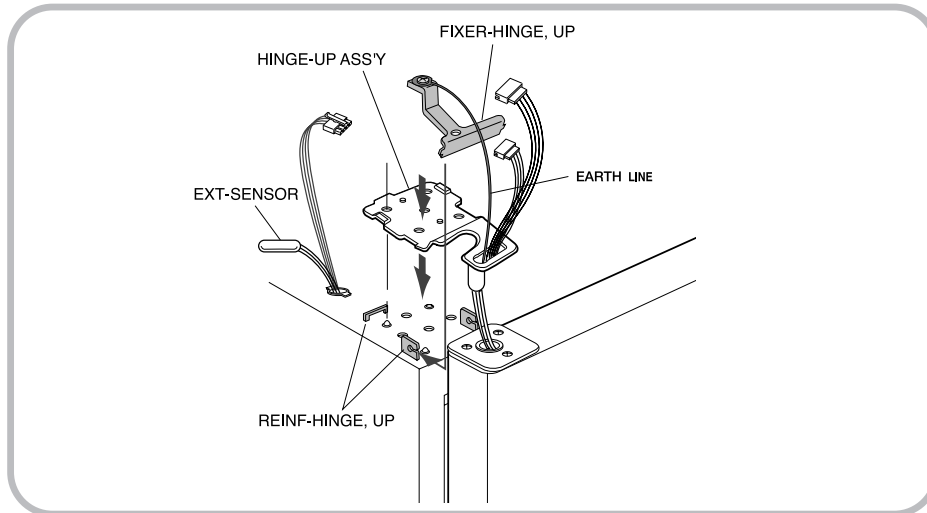

2. HINGE-UP ASS'Y Method

- 1) After inserting HINGE-UP ASS'Y to REINF-HINGE UP in the direction, combine it by rotating it in the direction.
- 2) After inserting FIXER-HINGE UP to REINF-HINGE UP in the direction, assemble it by rotating it in the direction.

3. HINGE-UP ASS'Y Disassembly Method

- Disassemble it in reverse order of assembly method.

14. Refrigerator Exploded View & List

14-1) Freezer Room Exploded View (SR-S2026, S2027, S2226, S2227/S20NTC, S20BTC, S22NTC, S22BTC)

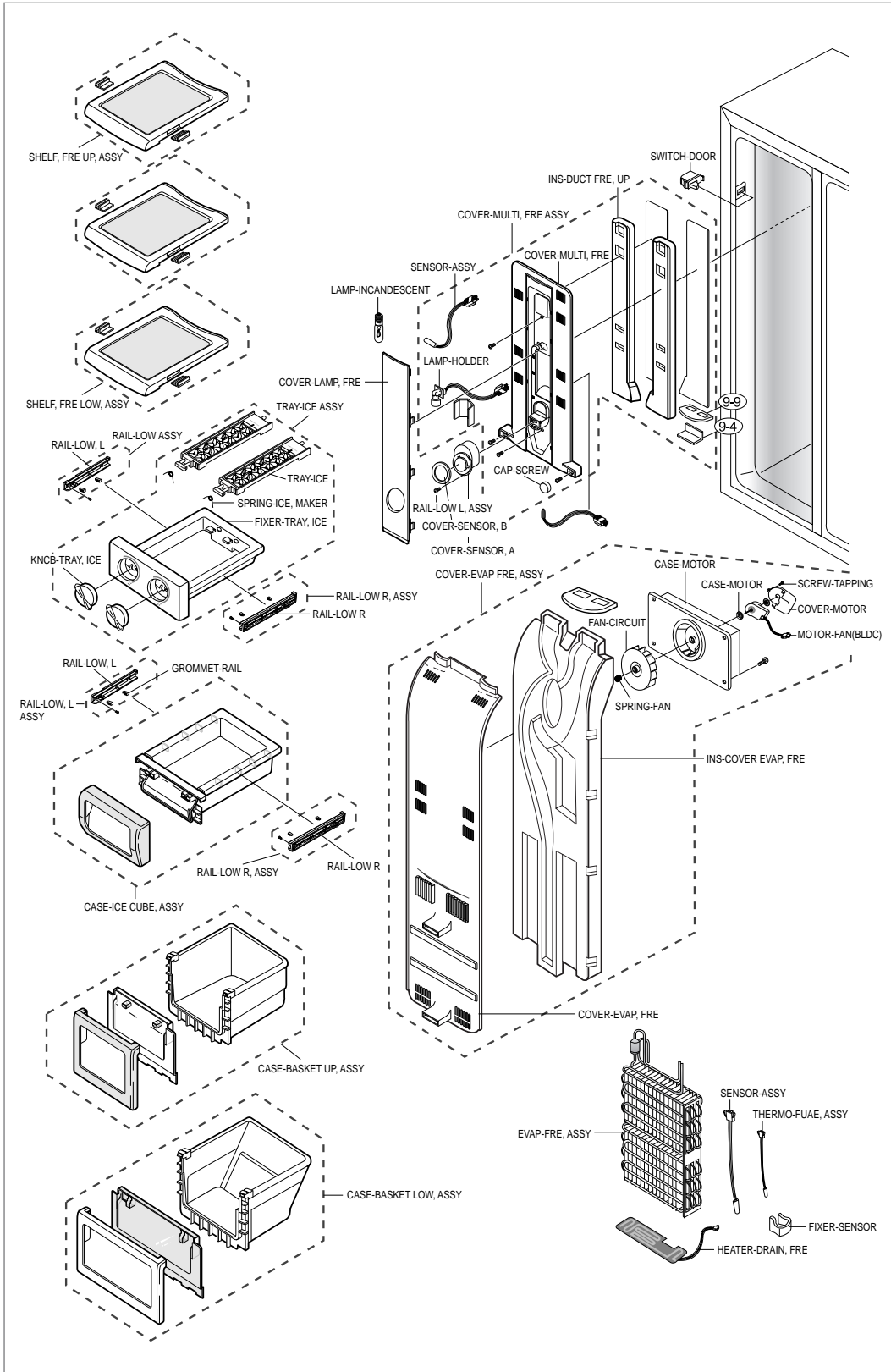

■ Accessory Parts of Freezer Room (SR-S2026, S2027, S2226, S2227/S20NTC, S20BTC, S22NTC, S22BTC)

NO	CODE-NO	Product Name	Specification	Quantity	Remark
1	4713-001123	LAMP-INCANDESCENT	240V, 30W, 25×84mm	1	Fusible Type
2	6002-000215	SCREW-TAPPING	TH-1, M4×16, ZPC(YEL), MSWR10	12	
3	DA34-10120A	SWITCH-DOOR	125V/250V, 0.5A, PA6, WHT	1	
4	DA97-00339B	HEATER-DRAIN, FRE	230V, 41W	1	
5	DA96-00014B	EVAP-FRE, ASSY	230V/230W	1	
5-1	DA32-10109R	SENSOR-ASSY	502AT, L540, YELLOW	1	(DEFROST SENSOR)
5-2	DA47-10148J	THERMO-FUSE, ASSY	250, 10A, 77°C	1	
5-3	DA71-00092A	FIXER-SENSOR	STS304, T0.5	1	
6	DA63-00155A	COVER-LAMP, FRE	PP	1	
7	DA63-00162A	COVER-SENSOR, B	ABS	1	
8	DA63-00178A	COVER-SENSOR, A	GPPS	1	
9	DA63-00231C	COVER-MULTI FRE, ASSY	PP	1	
9-1	DA32-10105H	SENSOR-ASSY	502AT, TEMP CAP TYPE	1	
9-2	DA47-40112W	LAMP-HOLDER	E-14 BASE, 240V	1	(FREEZER INSIDE SENSOR)
9-3	DA63-00154A	COVER-MULTI, FRE	PP	1	
9-4	DA70-00218A	PLATE-INS, DUCT	RD-PVC, T1.2	2	
9-5	DA71-00158A	REINF-COVER, MULTI	AL, T0.5, FRE	1	
9-6	DA72-00141A	INS-DUCT FRE, UP	FOAM-PS, FRE	1	
9-7	DA72-00158D	SEAL-COVER MULTI, FRE	"L", HOMO-PE, T0.35	1	
9-8	DA72-00159C	SEAL-COVER MULTI, FRE	"R", HOMO-PE, T0.35	1	
9-9	DA72-00226C	SEAL-AIR FRE, UP	OJC-3000, T.7	1	
10	DA67-30367B	CAP-SCREW	SILICON	2	
11	DA97-00360B	COVER-EVAP FRE, ASSY	PP, 230V	1	
11-1	DA31-00027A	MOTOR-FAN(BLDC)	220V/50Hz, UDQM002H4ASS, 2650rpm	1	
11-2	DA31-00016A	FAN-CIRCUIT	ABS, φ95	1	
11-3	DA61-20128A	SPRING-FAN	STS27, ID.1.0, P17.8	1	
11-4	DA63-00153B	COVER-EVAP, FRE	PP	1	
11-5	DA63-00184A	COVER-MOTOR	PP, BLDC	1	
11-6	DA63-00423A	GROMMET-MOTOR	NBR, BLK	2	
11-7	DA67-00158A	CASE-MOTOR	PP, BLDC	1	
11-8	6002-000215	SCREW-TAPPING	TH-1, M4×16, ZPC(YEL), MSWR10	4	

Indicated part is for electrical safety components

NO	CODE-NO	Product Name	Specification	Quantity	Remark
11-9	DA72-00227A	SEAL-AIR EVAP, FRE	OJC-3000, BLK, T.5	1	
11-10	DA72-00141A	INS-COVER EVAP, FRE	FOAM-PS	1	
11-11	6002-000471	SCREW-TAPPING	TH-1,M4×12, STS304	1	
12	DA61-60183B	RAIL-LOW L, ASSY	HIPS, SC-93437R	2	
12-1	DA61-60179A	RAIL-LOW, L	HIPS, SC-93437R	2	
12-2	DA63-40256B	GROMMET-RAIL	NY-66, SC-93437R	4	
13	DA61-60184B	RAIL-LOW R, ASSY	HIPS, SC-93437R	2	
13-1	DA61-60180A	RAIL-LOW, R	HIPS, SC-93437R	2	
13-2	DA63-40256B	GROMMET-RAIL	NY-66, SC-93437R	4	
14	DA67-00182C	CASE-BASKET UP, ASSY		1	
14-1	DA63-00170C	COVER-BASKET FRONT, A	HIPS	1	
14-2	DA63-00174C	COVER-BASKET FRONT, B	GPPS	1	
14-3	DA67-00150A	CASE-BASKET, UP	PP	1	
15	DA67-00183C	CASE-BASKET LOW, ASSY		1	
15-1	DA63-00170C	COVER-BASKET FRONT, A	HIPS	1	
15-2	DA63-00174C	COVER-BASKET FRONT, B	GPPS	1	
15-3	DA67-00151A	CASE-BASKET, LOW	PP	1	
16	DA67-00180A	SHELF-FRE UP, ASSY		1	
16-1	DA64-00090A	TRIM-SHELF	PE, T1.0	4	
16-2	DA67-00175A	SHELF-FRE, UP	HIPS+GLASS	2	
17	DA67-00181A	SHELF-FRE LOW, ASSY		1	
17-1	DA64-00090A	TRIM-SHELF	PE, T1.0	2	
17-2	DA67-00146A	SHELF-FRE, LOW	HIPS	1	
18	DA66-00047A	TRAY-ICE, ASSY		1	
18-1	DA61-20136A	SPRING-ICE, MAKER	STS304, ID1.0	2	
18-2	DA64-00084A	KNOB-TRAY, ICE	HIPS	2	
18-3	DA66-00032A	TRAY-ICE	W9540	2	
18-4	DA71-00059A	FIXER-TRAY, ICE	HIPS	1	
19	DA67-00186A	CASE-ICE CUBE, ASSY		1	
19-1	DA63-00179A	COVER-TRAY	HIPS	1	
19-2	DA67-00155A	CASE-TRAY, ICE	GPPS	1	

14-2) Refrigerator Room Exploded View(SR-S20.. ~ S22..)

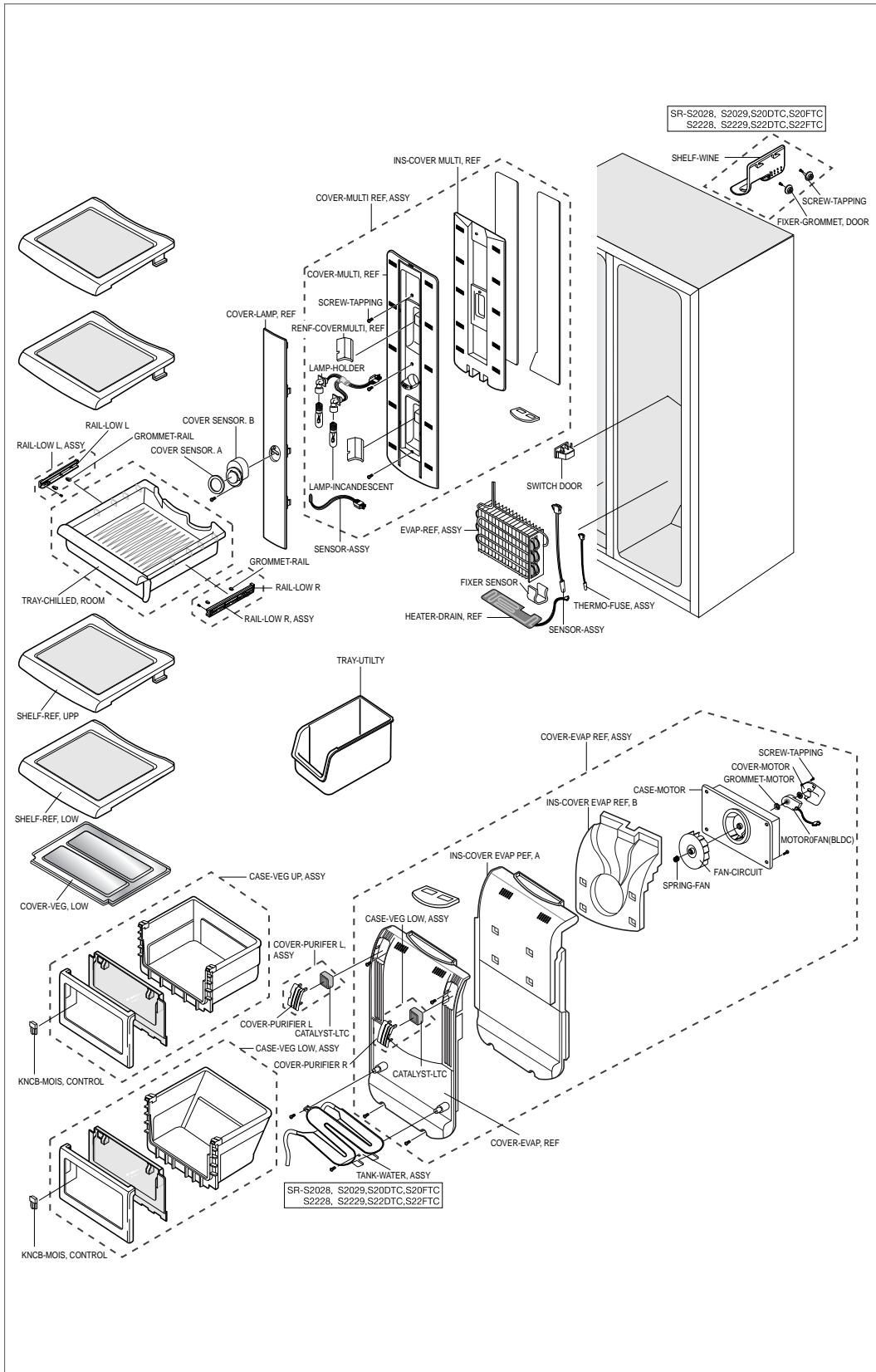

■ Accessory Parts of Refrigerator Room(SR-S20..~S22..)

NO	CODE-NO	Product Name	Specification	Quantity	Remark
1	6002-000215	SCREW-TAPPING	TH-1, M4×16, ZPC(YEL), MSWR1	10	
2	DA34-10110B	SWITCH-DOOR	125/1.5A.25	1	
3	DA47-00022B	HEATER-DRAIN, REF	240V, 25W, 1210 Ω	1	
4	DA96-00013B	EVAP-REF, ASSY	230V/50, 110W	1	
4-1	DA32-10109N	SENSOR-ASSY	502AT, L370, YELLOW	1	(DEFROST SENSOR)
4-2	DA47-10148J	THERMO-FUSE, ASSY	250V, 77°C	1	
4-3	DA61-00453A	FIXER-SENSOR	ABS, MOULDING	1	
5	4713-001123	LAMP-INCANDESCENT	240V, 30W, TRP, 25×84mm	2	Fusible Type
6	DA63-00218A	COVER-MULTI REF, ASSY		1	
6-1	DA32-10105H	SENSOR-ASSY	502AT, TEMP CAP TYPE	1	(FREEZER INSIDE SENSOR)
6-2	DA47-40112Y	LAMP-HOLDER	E-14 BASE, 240V	1	
6-3	DA63-00158A	COVER-MULTI, REF	PP	1	
6-4	DA71-00149A	REINF-COVER MULTI, REF	AL, T0.5	2	
6-5	DA72-00144A	INS-COVER MULTI, REF	FOAM-PS	1	
6-6	DA72-00154B	SEAL-DUCT, REF	OJC-3007, T5	1	
6-7	DA72-00156A	SEAL-CUTT, FOAM PE	FOAM-PE, T2	1	
6-8	DA72-00156B	SEAL-CUTT, FOAM PE	HOMO-PP, T0.35	1	
7	DA63-00160A	COVER-LAMP, REF	PP	1	
8	DA63-00162A	COVER-SENSOR, B	ABS	1	
9	DA63-00178A	COVER-SENSOR, A	GPPS	1	
10	DA63-00218A	COVER-EVAP REF, ASSY	PP, 220V	1	
10-1	DA31-00027A	MOTOR-FAN(BLDC)	UDQM002H4ASS, 2650rpm	1	
10-2	DA31-00016A	FAN-CIRCUIT	ABS, ∅ 95	1	
10-3	DA61-20128A	SPRING-FAN	STS27, ID1, P17.8	1	
10-4	DA63-00159A	COVER-EVAP REF	PP	1	
10-5	DA63-00184A	COVER-MOTOR	PP, BLDC	1	
10-6	DA63-40119A	GROMMET-MOTOR	NBR, BLK	2	
10-7	DA67-00158A	CASE-MOTOR	PP, BLDC	1	
10-8	6002-000215	SCREW-TAPPING	TH-1, M4×16, ZPC(YEL), MSWR1	4	
10-9	6002-000471	SCREW-TAPPING	TH-1, M4×12, STS304	1	

Indicated part is for electrical safety components

NO	CODE-NO	Product Name	Specification	Quantity	Remark
10-10	DA72-00142A	INS-COVER EVAP REF, A	FOAM-PS	1	
10-11	DA72-00143A	INS-COVER EVAP REF, B	FOAM-PS	1	
10-12	DA72-00229A	SEAL-AIR REF, UP	OJC-3000, BLK, T5	1	
11	DA63-00365B	COVER-PURIFIER L, ASSY	ABS, WHT	1	
11-1	DA02-90106J	CATALYST-LTC	LTC, SS-400-15-2, T.15	1	
11-2	DA63-00163A	COVER-PURIFIER, L	ABS	1	
12	DA63-00366B	COVER-PURIFIER R, ASSY	ABS, WHT	1	
12-1	DA02-90106J	CATALYST-LTC	LTC, SS-400-15-2, T.15	1	
12-2	DA63-00164A	COVER-PURIFIER, R	ABS	1	
13	DA67-40250F	TRAY-UTILITY	GPPS, NTR	1	
14	DA67-00148A	SHELF-REF, LOW	PP+GLASS	1	
15	DA67-00149A	SHELF-REF, UP	PP+GLASS	3	
16	DA66-00038A	TRAY-CHILLLED, ROOM	GPPS	1	
17	DA61-60183B	RAIL-LOW L, ASSY	HIPS, SC-93437R	1	
17-1	DA61-60179A	RAIL-LOW, L	HIPS, SC-93437R	1	
17-2	DA63-40256B	GROMMET-RAIL	NY-66, SC-93437R	2	
18	DA61-60184B	RAIL-LOW R, ASSY	HIPS, SC-93437R	1	
18-1	DA61-60180A	RAIL-LOW, R	HIPS, SC-93437R	1	
18-2	DA63-40256B	GROMMET-RAIL	NY-66, SC-93437R	2	
19	DA63-10942A	COVER-VEG, LOW	PP, T2.5	1	
20	DA67-00184A	CASE-VEG UP, ASSY		1	
20-1	DA63-00175A	COVER-VEG FRONT, A	HIPS	1	
20-2	DA63-00177A	COVER-VEG FRONT, B	GPPS	1	
20-3	DA64-00085A	KNOB-MOIS, CONTROL	HIPS	1	
20-4	DA67-00152A	CASE-VEG, UP	PP	1	
21	DA67-00185A	CASE-VEG LOW, ASSY		1	
21-1	DA63-00175A	COVER-VEG FRONT, A	HIPS	1	
21-2	DA63-00177A	COVER-VEG FRONT, B	GPPS	1	
21-3	DA64-00085A	KNOB-MOIS, CONTROL	HIPS	1	
21-4	DA67-00153A	CASE-VEG, LOW	PP	1	
22	DA67-4-250C	TRAY-UTILITY	GPPS NTR	1	
23	DA67-00145A	SHELF-WINE	HIPS	1	
24	DA71-20252A	FIXER-GROMMET, DOOR	ABS, W9175	2	
25	DA74-00056C	TANK-WATER, ASS' Y	HP-PE	1	

14-3) Unit Exploded View(SR-S20..~S22..)

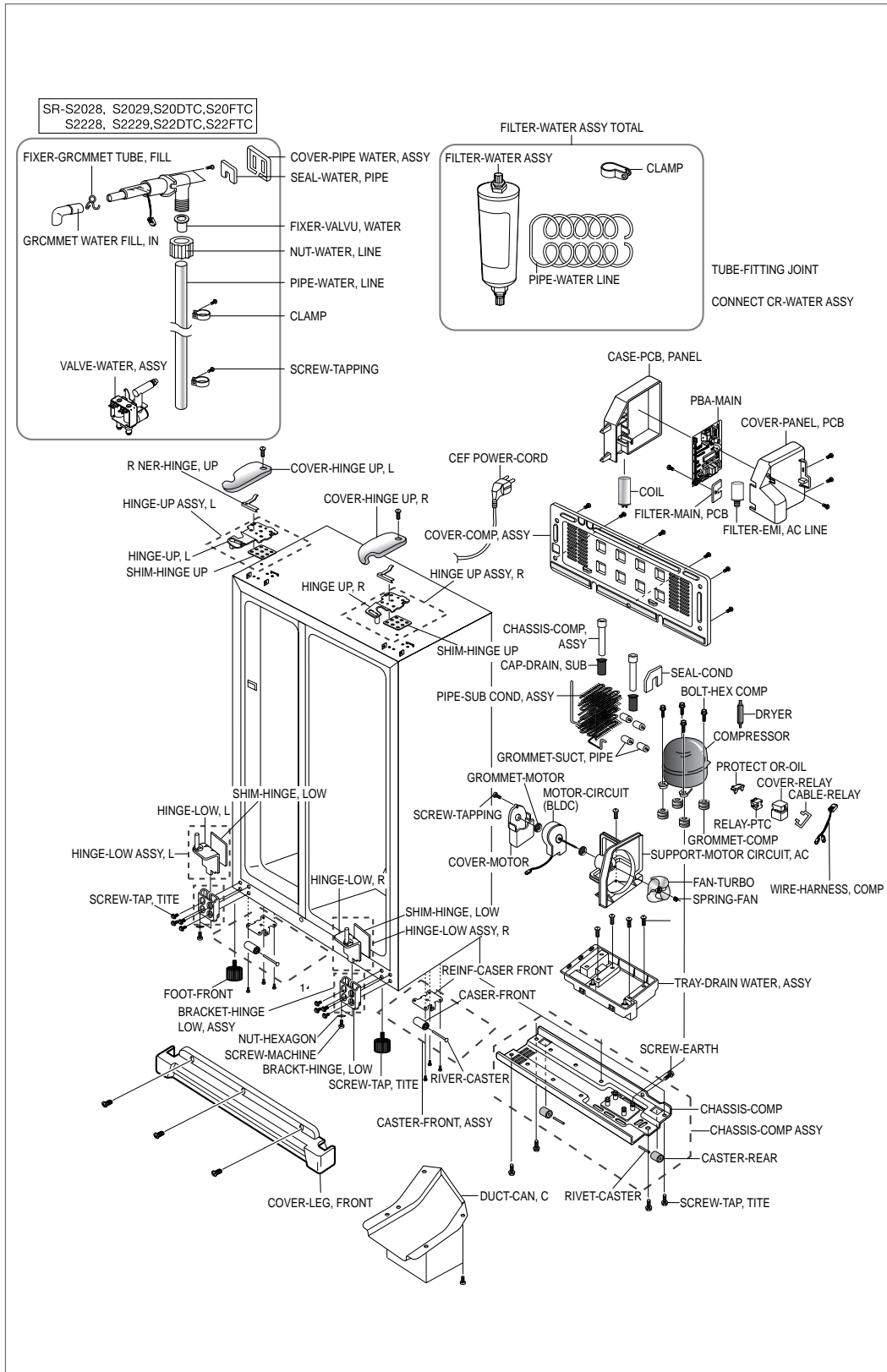

■ Part List of Unit Exploded View (SR-S20..~S22..)

NO	CODE-NO	Product Name	Specification	Quantity	Remark
1	DA90-00243K	CABI-FOAM, ASSY	S/WHITE, SC-97527T	1	
2	DA63-00201B	COVER-HINGE UP, L	ABS, SC-97527R, S/WHITE	1	
3	DA61-00059B	HINGE-UP ASSY, L	SHP1, T30	1	
3-1	DA61-00051B	HINGE-UP, L	SHP1, T30	1	
3-2	DA63-50192A	SHIM-HINGE, UP	RD-PVC, T1.0	1	
4	DA63-00200B	COVER-HINGE UP, R	ABS, SC-97527R, S/WHITE	1	
5	DA61-00058B	HINGE-UP ASSY, R	SHP1, T30	1	
5-1	DA61-00052B	HINGE-UP, R	SHP1, T30	1	
5-2	DA63-50192A	SHIM-HINGE, UP	RD-PVC, T1.0	1	
6	DA71-20267A	FIXER-HINGE, UP	SCP1, T3, ZPC3	2	
7	DA60-10123E	SCREW-TAP, TITE	HH, M6×19, ZPC2-W	8	
8	DA60-10122C	SCREW-TAP, TITE	HH, M5×16, ZPC2-W, WSWR10	6	
9	DA61-00056A	CASTER-FRONT, ASSY	SCP1	2	
9-1	DA60-90124A	RIVET-CASTER	MSWR10, OD6.0, L56, ZPC3	1	
9-2	DA61-40115A	CASTER-FRONT	NY-66, BLK, ID6, OD30	1	
9-3	DA71-00064A	REINF-CASTER, FRONT	SHP1, T25	1	
10	DA61-30102C	FOOT-FRONT	PP, L53	2	
11	DA74-00038A	DUCT-CABI, C	ABS	1	
12	DA71-00157A	BRACKET-HINGE LOW, ASSY	SHP1, T26, BLK	2	
12-1	6021-000162	NUT-HEXAGON	ZC, M6, ZPC(YEL), SM20C	2	
12-2	DA60-10146A	SCREW-MACHINE	HWH, M5×16, ZPC2, SWRCH10A	2	
12-3	DA71-00131A	BRACKET-HINGE, LOW	SHP1, T26, BLK	1	
13	DA61-00112A	HINGE-LOW ASSY, L	SHP1, T45	1	
13-1	DA61-00096A	HINGE-LOW L	SHP1, T45, BLK	1	
13-2	DA63-50207B	SHIM-HINGE, LOW	RD-PVC, T1.0	1	
14	DA61-00111A	HINGE-LOW ASSY, R	SHP1, T45	1	
14-1	DA61-00095A	HINGE-LOW, R	SHP1, T45, BLK	1	
14-2	DA63-50207B	SHIM-HINGE, LOW	RD-PVC, T1.0	1	
15	DA31-00027B	MOTOR-CIRCUIT(BLDC)	240V/50Hz, UDQM002H4ASS, 2650rpm	1	
16	DA31-00015A	FAN-TURBO	ABS	1	

Indicated part is for electrical safety components

NO	CODE-NO	Product Name	Specification	Quantity	Remark
17	DA61-20128A	SPRING-FAN	STS27, ID1.0, P17.8	1	
18	DA63-00184A	COVER-MOTOR	PP, BLDC	1	
19	DA61-00047A	SUPPORT-MOTOR CIRCUIT, AC	PP, T20, BLDC	1	
20	DA63-00423A	GROMMET-MOTOR	NBR, BLK	2	
21	6002-000213	SCREW-TAPPING	TH-1, M4×12, ZPC(YEL), SWRCH18	19	
22	DA66-00075A	TRAY-DRAIN WATER, ASSY	PP	1	
23	DA63-10352A	COVER-RELAY	BLK, HOOK TYPE	1	
24	6502-000156	CABLE-CLAMP	DAMC-103, SPC1, PE FOAM	2	
25	DA34-10003F	PROTECTOR-O/L	4TM266RFBYY-53	1	
26	DA35-10013B	RELAY-PTC	J531Q35E330M385-2, 385V 6A	1	
27	DA39-00084B	WIRE-HARNESS, COMP	220V	1	
28		CBF(POWER-CORD)		1	
29	DA59-00145A	COMPRESSOR	*DK182QL2U	1	
30	DA63-40004A	GROMMET-COMP	NBR, BLK	5	
31	DA60-20008A	BOLT-HEX, COMP	SM30C, M6, L42.6	4	
32	DA60-10105B	SCREW-TAPPING	PH-1, P14.0, L23, ZPCS-Y, SWRCH1	4	
33	DA60-10107A	SCREW-EARTH	M4-10, BSBN	2	
34	DA60-10124A	SCREW-TAP, TITE	HH, M6×16, ZPC2-Y	10	
35	DA61-00055A	CASE-PCB, PANEL	PP	1	
36	DA71-00155A	FIXER-MAIN, PCB	RD-PVC, T20, NTR	1	
37	DA41-00024A	PBA-MAIN	T1.6*197*123, MAIN PCB ASSY	1	BASIC TYPE
	DA41-00027A	PBA-MAIN	T1.6*197*123, MAIN PCB ASSY	1	ICE & WATER DISP
38	2501-001186	C-OIL	5uF, 350V, BK, 43×55mm	1	
39	DA27-00002A	FILTER-EMI, AC LINE	250V, 10A, 33000uF, 38×50mm	1	
40	DA63-00212A	COVER-PANEL, PCB	PP, T27	1	
41	DA67-00176A	CAP-DRAIN, SUB	NBR, BLK	2	
42	DA74-00044A	HOSE-DRAIN, SUB	LD-PE	2	
43	DA71-00089A	CHASSIS-COMP, ASSY	SBHG1, T1.2	1	
43-1	DA60-90101A	RIVET-CASTER	ZPC2, MSWR10	2	
43-2	DA61-40101C	CASTER-REAR	PP, NTR, BJ-730	2	
43-3	DA71-00058A	CHASSIS-COMP	SBHG1, T1.2	1	

NO	CODE-NO	Product Name	Specification	Quantity	Remark
44	DA72-00176A	SEAL-COND	FOAM-PE, T.7	1	
45	DA63-40171B	GROMMET-SUCT, PIPE	NR, BLK	2	
46	DA63-40171D	GROMMET-SUCT, PIPE	NR, BLK	2	
47	DA73-00078C	PIPE-SUB COND, ASSY	SWST ϕ 4.76	1	
48	DA73-30102A	DRYER	Cu OD18.85L102	1	
49	DA63-00278C	COVER-COMP, ASSY	SBHG1, T0.4	1	
50	DA63-00189B	COVER-LEG, FRONT	HIPP, SC-97527R, S/WHITE	1	
51	DA63-00422A	GROMMET-WATER FILL, IN	SILICON, NTR	1	
52	DA63-00400A	FIXER-GROMMET TUBE, FILL	STS304	1	
53	DA73-00136A	PIPE-WATER FRE. ASSY	AL, 240V 7W	1	
54	DA71-20207A	FIXER-VALVE. WATER	NY-6, NTR	2	
55	DA60-30104A	NUT-WATER. LINE	NY-6	1	
56	DA73-00070C	PIPE-WATER. LINE	LDPE, L2300	1	
57	DA65-20110B	CLAMP	DN-5N, NY-66	6	
58	DA74-40149C	VALVE-WATER. ASSY	RIV-12A-4, 220-240V	1	
59	DA72-00228B	SEAL-WATER. PIPE	FOAM-PE, T10	1	
60	DA63-00432A	COVER-PIPE WATER. ASSY	GALVA+SPONGE	1	

14-4) Freezer Room Exploded View (SR-S2028, S2029, S2228, S2229/S20DTC, S20FTC, S22DTC, S22FTC)

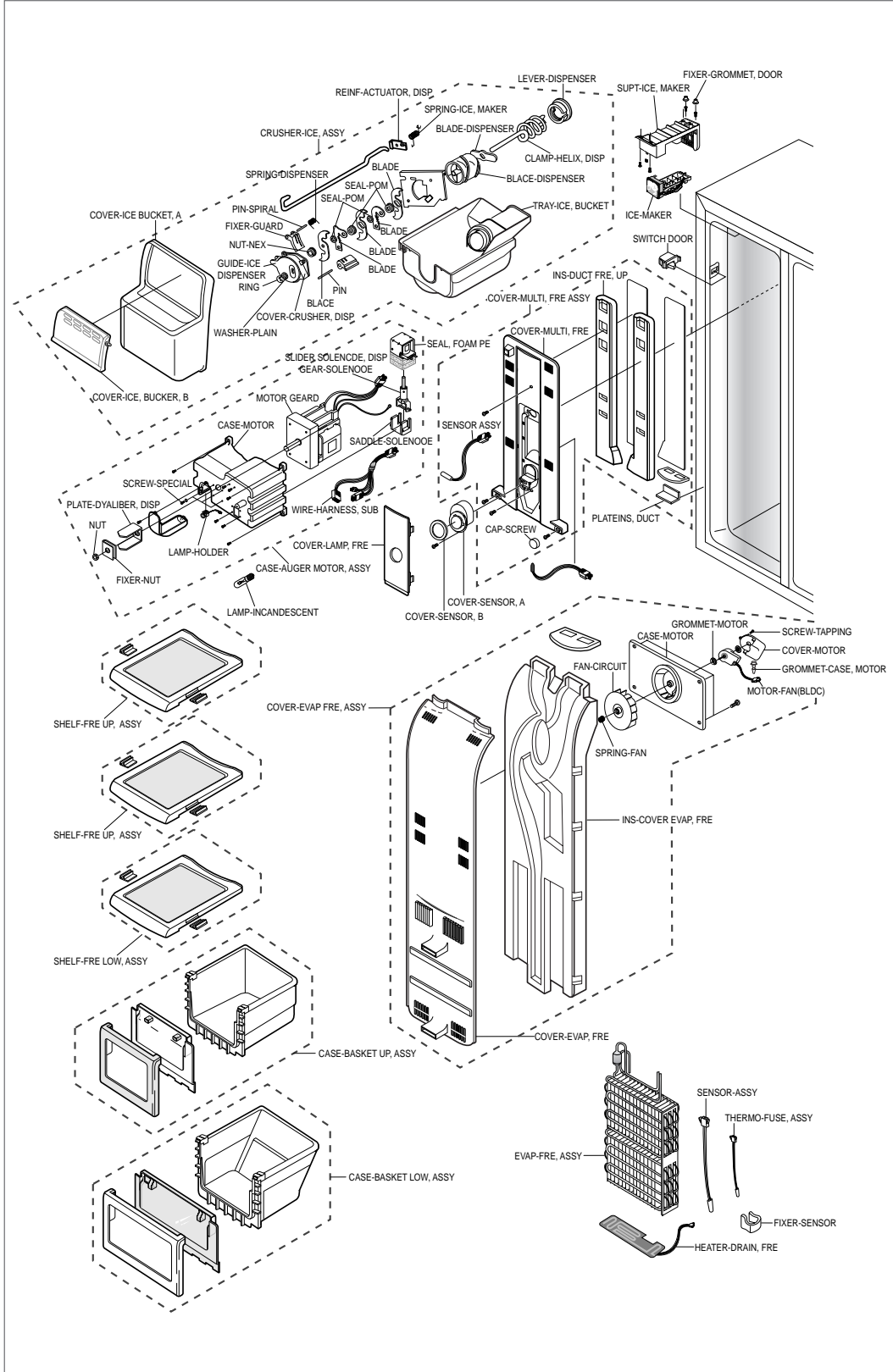

■ Part List of Freezer Room (SR-S2028, S2029, S2228, S2229/S20DTC,S20FTC,S22DTC,S22FTC)

NO	CODE-NO	Product Name	Specification	Quantity	Remark
1	4713-001123	LAMP-INCANDESCENT	240V, 30W, 25×84mm	1	Fusible Type
2	6002-000215	SCREW-TAPPING	TH-1, M4×16, ZPC(YEL), MSWR10	12	
3	DA34-10120A	SWITCH-DOOR	125V/250V, 0.5A, PA6, WHT	1	
4	DA47-00023B	HEATER-DRAIN, FRE	240V, 25W	1	
5	DA59-00068D	EVAP-FRE, ASSY	220V/200W	1	
5-1	DA32-10109R	SENSOR-ASSY	502AT, L540, YELLOW	1	(Defrost Sensor)
5-2	DA47-10115A	THERMO-FUSE, ASSY	250, 10A, 72°C	1	
5-3	DA71-00092A	FIXER-SENSOR	STS304, T0.5	1	
6	DA63-00155A	COVER-LAMP, FRE	PP	1	
7	DA63-00162A	COVER-SENSOR, B	ABS	1	
8	DA63-00178A	COVER-SENSOR, A	GPPS	1	
9	DA63-00231B	COVER-MULTI FRE, ASSY	PP, ET-PJT	1	
9-1	DA32-10105H	SENSOR-ASSY	502AT, TEMP CAP TYPE	1	(Freezer Inside Sensor)
9-2	DA63-00363A	COVER-MULTI, FRE	PP	1	
9-3	DA70-00218A	PLATE-INS, DUCT	RD-PVC, T1.2	2	
9-4	DA72-00245A	INS-DUCT FRE. UP	FOAM-PS, FRE	1	
9-5	DA72-00158D	SEAL-COVER MULTI, FRE	"L", HOMO-PE, T0.35	1	
9-6	DA72-00159C	SEAL-COVER MULTI, FRE	"R", HOMO-PE, T0.35	1	
9-7	DA72-00226C	SEAL-AIR FRE, UP	OJC-3000, T.7	1	
10	DA67-30367B	CAP-SCREW	SILICON	2	
11	DA63-00232B	COVER-EVAP FRE, ASSY	ET-PJT 240V	1	
11-1	DA31-00027A	MOTOR-FAN(BLDC)	UDQM002H4ASS, 2650rpm	1	
11-2	DA31-00016A	FAN-CIRCUIT	ABS, ø 95	1	
11-3	DA61-20128A	SPRING-FAN	STS27, ID.1.0, P17.8	1	
11-4	DA63-00153B	COVER-EVAP, FRE	PP	1	
11-5	DA63-00184A	COVER-MOTOR	PP, BLDC	1	
11-6	DA63-00423A	GROMMET-MOTOR	NBR, BLK	2	
11-7	DA67-00158A	CASE-MOTOR	PP, BLDC	1	
11-8	6002-000215	SCREW-TAPPING	TH-1, M4×16, ZPC(YEL), MSWR10	4	
11-9	DA72-00227A	SEAL-AIR EVAP, FRE	OJC-3000, BLK, T.5	1	
11-10	DA72-00141A	INS-COVER EVAP, FRE	FOAM-PS	1	

Indicated part is for electrical safety components

NO	CODE-NO	Product Name	Specification	Quantity	Remark
11-11	6002-000471	SCREW-TAPPING	TH-1,M4×12, STS304	1	
11-12	DA63-00417A	GROMMET-CASE, MOTOR	NBR, GRY	1	
12	DA67-00182A	CASE-BASKET UP, ASSY	ET-P/J	1	
12-1	DA63-00170A	COVER-BASKET FRONT, A	HIPS	1	
12-2	DA63-00174C	COVER-BASKET FRONT, B	GPSS	1	
12-3	DA67-00150C	CASE-BASKET, UP	PP	1	
13	DA67-00183C	CASE-BASKET LOW, ASSY	ET-P/J	1	
13-1	DA63-00170A	COVER-BASKET FRONT, A	HIPS	1	
13-2	DA63-00174C	COVER-BASKET FRONT, B	GPSS	1	
13-3	DA67-00151C	CASE-BASKET, LOW	PP	1	
14	DA67-00179C	SHELF-FRE UP, ASSY	ET-P/J	2	
14-1	DA64-00090A	TRIM-SHELF	PE, T1.0	4	
14-2	DA67-00170A	SHELF-FRE, UP	HIPS+GLASS	1	
15	DA67-00181A	SHELF-FRE LOW, ASSY	ET-P/J	1	
15-1	DA64-00090A	TRIM-SHELF	PE, T1.0	2	
15-2	DA67-00146A	SHELF-FRE, LOW	HIPS	1	
16	DA66-00181B	SHELF-FRE LOW, ASSY	ET-P/J	1	
16-1	DA61-20136A	TRIM-SHELF	PE, T1.0	2	
16-2	DA64-00146A	SHELF-FRE, LOW	HIPS	1	
17	DA61-70253B	SUPT-ICE,MAKER	HIPS	1	
18	DA71-20252A	FIXER-GROMMET,DOOR	ABS,W9175	2	
19	DA71-20270A	FIXER-CASE	NBR,SD-8922,T2.5	3	
20	DA59-30103E	ICE-MAKER	ZIPEL,DC 12V,DC 5V	1	
21	DA59-00136A	CRUSHER-ICE,ASSY	ET-PJT	1	
21-1	DA65-20121A	CLAMP-HELIX,DISP	STS304,08	1	
21-2	DA31-20123A	BLADE-DISPENSER	STS420-J2,T2.0	1	
21-3	DA31-20009A	BLADE-DISPENSER	PC,SR-S7240,0D113,T2	1	
21-4	DA31-20120C	BLADE	STS420-J2, T2.0	1	
21-5	DA72-60314A	SEAL-POM	CRUSHER MID, POM	2	
21-6	DA71-20231A	FIXER-GUARD	POM, W9236E	1	
21-7	DA31-20122A	BLADE	STS420-J2, SR-S7180, T2.0	1	

NO	CODE-NO	Product Name	Specification	Quantity	Remark
21-8	DA31-20121A	BLADE	STS420-J2, SR-S7180, T2.0	1	
21-9	DA60-90135A	PIN-SPIRAL	STS420-J2,SR-S7180,T2.0	1	
21-10	DA72-60313A	SEAL-POM	STS420-J2,SR-S7180,T2.0	2	
21-11	DA31-20120B	BLADE	STS420-J2, SR-S7180, T2.0	1	
21-12	DA31-20120A	BLADE	STS420-J2, SR-S7180, T2.0	1	
21-13	DA60-30108A	NUT-HEX	HEX, POM	1	
21-14	DA70-20160B	PLATE-FRONT,DISP	STS304,T1.0	1	
21-15	DA63-10016A	COVER-CRUSHER,DISP	PC/ABS,SC-90417R	1	
21-16	DA71-7003A	GUIDE-ICE,DISPENSER	PC/ABS	1	
21-17	DA61-20124A	SPRING-DISPENSER	STS304,P11.0	1	
21-18	DA60-90135A	PIN	STS304,OD2.4,L51.7,SR-S7180	1	
21-19	DA60-40116A	WASHER-PLAIN	IC20,OD28,T0.5,STS	1	
21-20	DA60-90125A	RING	SK-5H,SR-S7180	1	
21-21	6001-000033	SCREW-MACHINE	TH,M4,L10,STS304	3	
21-22	DA66-00033A	TRAY-ICE,BUCKET	W9540	1	
21-23	DA66-30138A	LEVER-DISPENSER	POM,W9236E,DELRI5	1	
21-24	DA72-60315A	SEAL-EPDM	BUCKET DISP,EPDM	1	
21-25	6002-000471	SCREW-TAPPING	TH,M4,L12,STS304	2	
21-26	DA66-30145A	LEVER-CUBE	MSWR10,-G-PJT,EPC3,DISPENSER	1	
21-27	DA61-20139A	SPRING-ICE,MAKER	STS304,ID0.7,P15.9	1	
21-28	DA71-10010A	REINF-ACTUATOR,DISP	SCP1,ZPC3	1	
21-29	6002-000475	SCREW-TAPPING	TH,M4,L20,STS304	5	
21-30	DA63-00180A	COVER-ICE,BUCKET,A	HIPP	1	
21-31	DA63-00181A	COVER-ICE,BUCKET,B	GPPS W9540B	1	
22	DA61-00143A	CASE-AUGER MOTOR, ASSY	HIPS, ET-PJT	1	
22-1	DA67-00144A	CASE-MOTOR	HIPP, AUGER	1	
22-2	DA31-10141D	MOTOR-GEARD	ISG-320SSD, 230V/50Hz,1.8AUSD-	1	
22-3	DA74-40154C	VALVE-SOLENOID	DPS4, SCP1	1	
22-4	DA72-60348A	SEAL-FOAM PE	SOLENOID, FOAM-PE	1	
22-5	DA66-90003A	GEAR-SOLENOID	POM, SC-93438R	1	
22-6	DA65-20107A	SADDLE-SOLENOID	NY-6, S7180	1	

NO	CODE-NO	Product Name	Specification	Quantity	Remark
22-7	DA63-90008A	BUSH-SOLENOID	POM, SC-93438R	1	
22-8	DA61-20140A	SPRING-SOLENOID	STS304, ID0.7, L30.1, P17.5	1	
22-9	DA60-90137A	PIN-SPRING	STS304, L22, OD2.8, T0.35	1	
22-10	DA60-90137B	PIN-SPRING	STS304, L16, OD2.8, T0.35	1	
22-11	DA61-60001A	SLIDER-SOLENOID, DISP	POM, WHT	1	
22-12	DA71-00163A	FIXER-NUT	STS420-J2	1	
22-13	DA70-20017A	PLATE-D/AUGER, DISP	STS304	1	
22-14	DA60-00001A	SCREW-SPECIAL	HEX, L8.3, STS-304	4	
22-15	DA60-00001B	SCREW-SPECIAL	HEX, L8.3, STS-304	4	
22-16	DA47-40112V	LAMP-HOLDER	UL-SPEC, PBT 5VA, E14	1	
22-17	DA39-00083A	WIRE-HARNESS, SUB	EXP, ET-PJT	1	
22-18	DA60-30109A	NUT	STS420-J2	1	

14-5) Freezer Room Door Exploded View (SR-S2026, S2027, S2226, S2227/S20NTC,S20BTC,S22NTC,S22BTC)

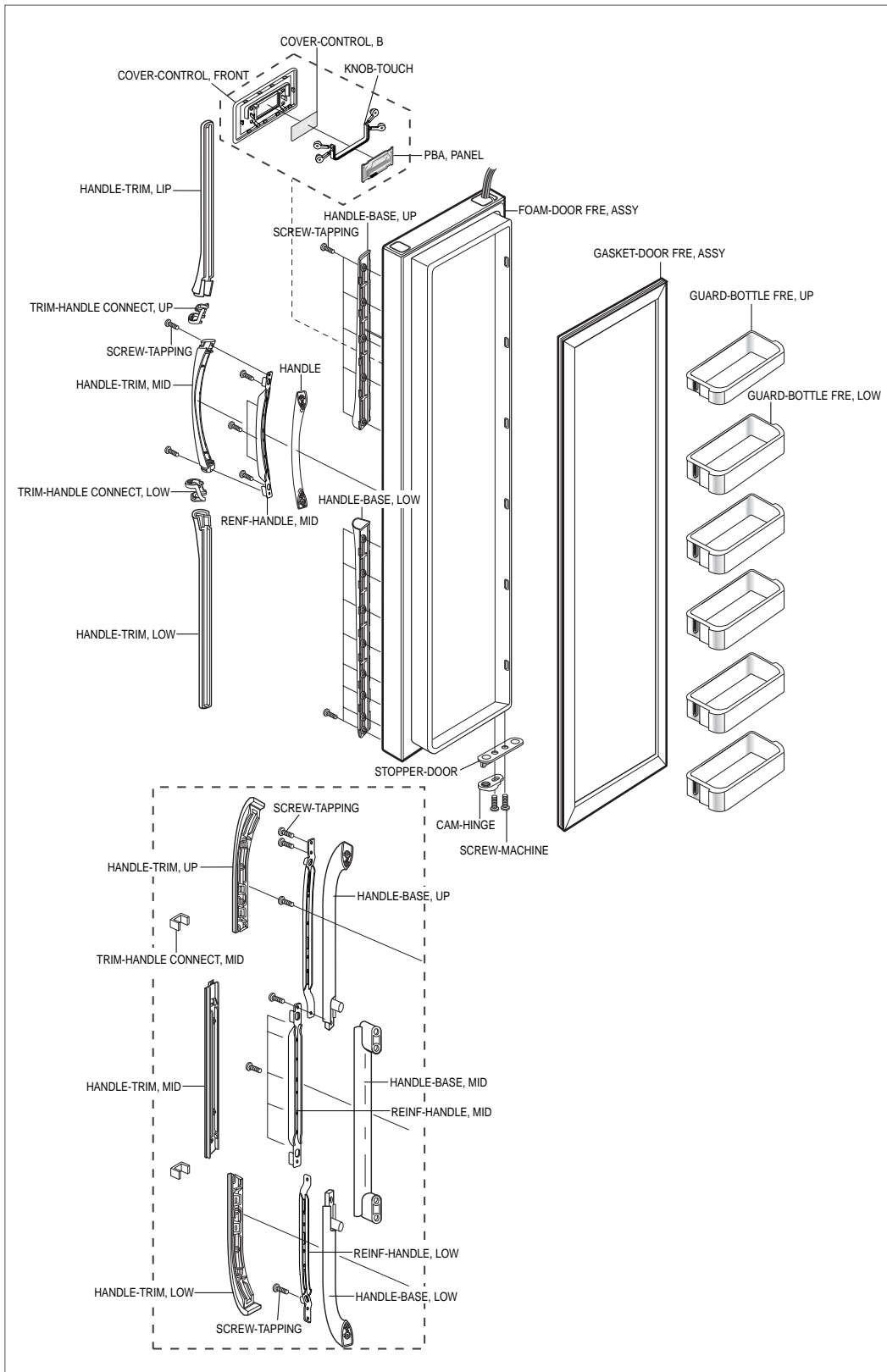

■ Part List of Freezer Room Door Exploded View (SR-S2026, S2027, S2226, S2227/S20NTC,S20BTC,S22NTC,S22BTC)

NO	CODE-NO	Product Name	Specification	Quantity	Remark
1	DA91-00655B	FOAM-DOOR FRE, ASSY	EMBO, SC-97527T S/WHITE, 50MM	1	SR-S2026,S2027,S20NTC,S20BTC
	DA64-00654B	FOAM-DOOR FRE, ASSY	EMBO, SC-97527T S/WHITE, 85MM	1	SR-S2226,S2227,S22NTC,S22BTC
2	DA64-00082B	HANDLE-TRIM, UP	ABS, SC-97527R	1	"D"-TYPE
3	DA64-00176B	TRIM-HANDLE CONNECT, UP	ABS	1	"
4	DA64-00081B	HANDLE-TRIM, MID	ABS, SC-97527R	1	"
5	DA64-00177B	TRIM-HANDLE CONNECT, LOW	ABS	1	"
6	DA64-00083B	HANDLE-TRIM, LOW	ABS, SC-97527R	1	"
7	6002-000458	SCREW-TAPPING	FH-2, M4×14, STS304	13	
8	DA64-00093A	HANDLE-BASE, UP	HIPS	1	"D"-TYPE
9	DA64-00094A	HANDLE-BASE, LOW	HIPS	1	"
10	DA64-00080B	HANDLE	HIPS, SC-97527R	1	"
11	DA71-00056A	REINF-HANDLE, MID	SBHG1, T1.4	1	"
12	6002-000470	SCREW-TAPPING	TH-1, M4×10, ZPC, SWRCH18A	3	
13	6002-000468	SCREW-TAPPING	PH-2S, M5×18, ZPC(YEL)	4	
14	DA71-00068A	STOPPER-DOOR	SHP1, T3, BLK	1	
15	DA66-90112A	CAM-HINGE	POM, G4078B	1	
16	6001-000715	SCREW-MACHINE	TH, M5×16, ZPC(YEL), SWRCH18A	2	
17	DA63-30231G	GASKET-DOOR FRE, ASSY	SF-PVC, MAGNET-85g	1	
18	DA63-00191B	COVER-CONTROL, FRONT	ABS, SC-97527R	1	
19	DA63-00190A	COVER-CONTROL, B	GPPS, T2.5	1	
20	DA41-00020A	PBA-PANEL	T1.6, PANEL PCB ASSY	1	
21	DA64-00089B	KNOB-TOUCH	ABS	1	
22	DA63-00213A	GUARD-BOTTLE FRE, UP	HIPP, 50MM	1	SR-S2026,S2027,S20NTC,S20BTC
	DA63-00214A	GUARD-BOTTLE FRE, UP	HIPP, 85MM	1	SR-S2226,S2227,S22NTC,S22BTC
23	DA63-00169A	GUARD-BOTTLE, FRE, LOW	HIPP, 50MM	5	SR-S2026,S2027,S20NTC,S20BTC
	DA63-00169A	GUARD-BOTTLE, FRE, LOW	HIPP, 85MM	1	SR-S2226,S2227,S22NTC,S22BTC
24	DA64-00097B	HANDLE-BASE, UP	ABS, SC-97527R	1	"C"-TYPE
25	DA64-00099B	HANDLE-TRIM, LOW	ABS, SC-97527R	1	"
26	DA64-00100A	HANDLE-TRIM, UP	ABS, SC-97527R	1	"
27	DA64-00096B	HANDLE-BASE, MID	ABS, SC-97527R	1	"
28	DA71-00077A	REINF-HANDLE, MID	SBHG1, T1.4	1	"
29	DA64-00095B	HANDLE-BASE, LOW	ABS, SC-97527R	1	"
30	DA71-00078A	REINF-HANDLE, LOW	SBHG1, T1.4	1	"
31	DA64-00098	HANDLE-TRIM, MID	ABS, SC-97527R	1	"
32	DA64-00196A	TRIM-HANDLE CONNECT, MID	ABS, Cr	2	"

14-6) Refrigerator Room Door Exploded View (SR-S2026, S2028, S2226, S2228/S20NTC, S20DTC, S22NTC, S22DTC)

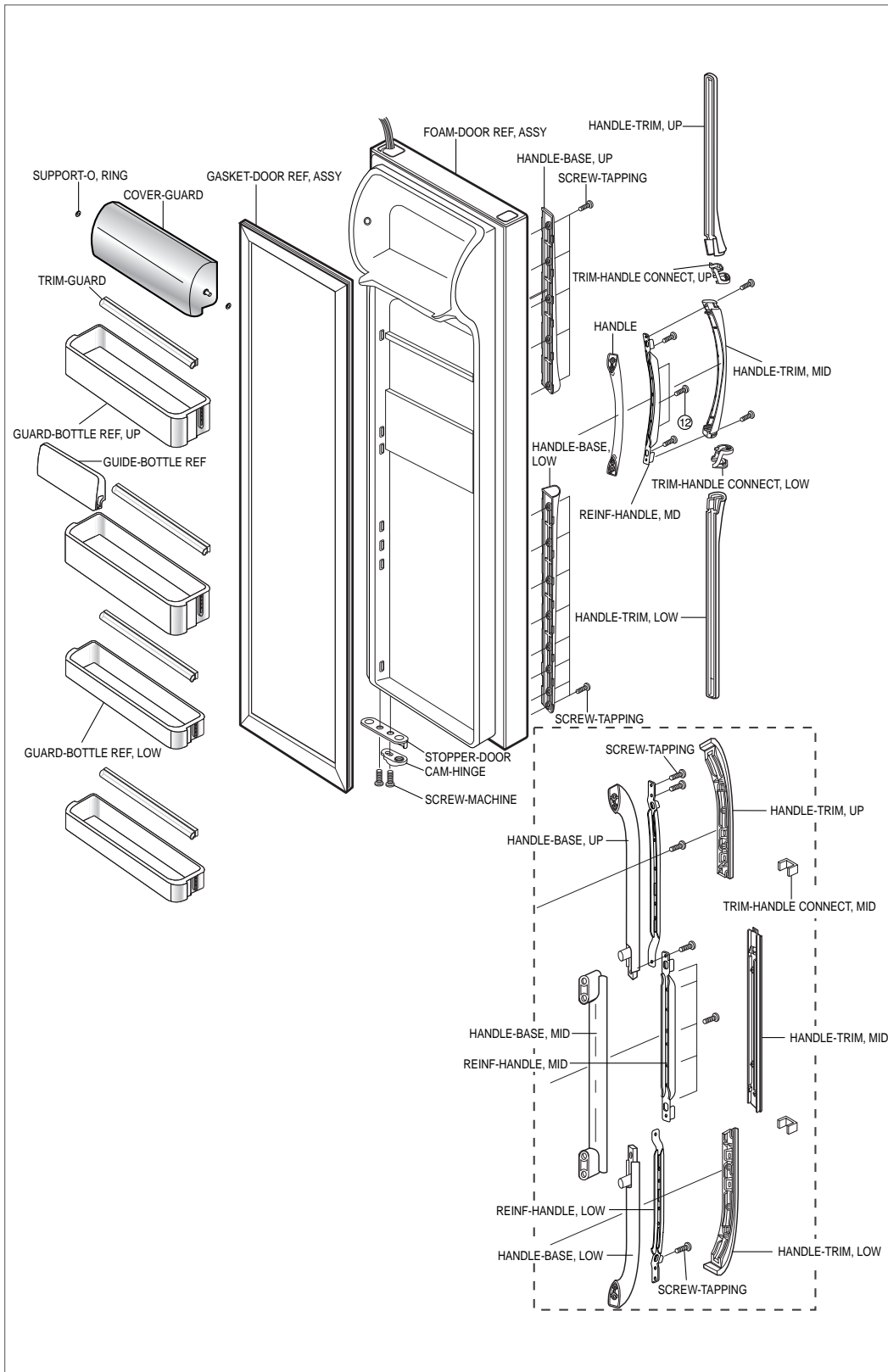

■ Part List of Refrigerator Room Door Exploded View (SR-S2026, S2028, S2226, S2228/S20NTC, S20DTC, S22NTC, S22DTC)

NO	CODE-NO	Product Name	Specification	Quantity	Remark
1	DA91-00659B	FOAM-DOOR REF, ASSY	EMBO, SC-97527T, S/WHITE 50MM	1	SR-S2026, S2028/S20NTC, S20DTC
	DA91-00658B	FOAM-DOOR REF, ASSY	EMBO, SC-97527T, S/WHITE 85MM	1	SR-S2226, S2228/S22NTC, S22DTC
2	DA64-00082B	HANDLE-TRIM, UP	ABS, SC-97527T, S/WHITE	1	"D"-TYPE
3	DA64-00176B	TRIM-HANDLE, CONNECT, UP	ABS	1	"
4	DA64-00081A	HANDLE-TRIM, MID	ABS, SC-97527T, S/WHITE	1	"
5	DA64-00177A	TRIM-HANDLE, CONNECT, LOW	ABS	1	"
6	DA64-00083B	HANDLE-TRIM, LOW	ABS, SC-97527T, S/WHITE	1	"
7	6002-000458	SCREW-TAPPING	FH, M4×14, STS304	13	
8	DA64-00093A	HANDLE-BASE, UP	HIPS	1	"D"-TYPE
9	DA64-00094A	HANDLE-BASE, LOW	HIPS	1	"
10	DA64-00080B	HANDLE	SC-97527T, S/WHITE	1	"
11	DA71-00056A	REINF-HANDLE, MID	SBHG1, T1.4	1	
12	6002-000470	SCREW-TAPPING	TH-1, M4×10, ZPC, SCRCH18A	3	
13	6002-000468	SCREW-TAPPING	PH-2S, M5×L18, ZPC(YEL), MAWR	4	
14	DA71-00068A	STOPPER-DOOR	SHP1, T3 BLK	1	
15	DA64-00122A	CAM-HINGE	POM, G4078B	1	
16	6001-000715	SCREW-MACHINE	TH, M5×16, ZPC(YEL), SWRCH18A	2	
17	DA63-30232G	GASKET-DOOR REF, ASSY	SF-PVC, MAGNET-85g	1	
18	DA63-00199A	COVER-GUARD	GPPS, 50MM	1	SR-S2026, S2028/S20NTC, S20DTC
	DA63-00176A	COVER-GUARD	GPPS, 85MM	1	SR-S2226, S2228/S22NTC, S22DTC
19	DA63-00168A	GUARD-BOTTLE REF, UP	HIPP, 50MM	2	SR-S2026, S2028/S20NTC, S20DTC
	DA63-00167A	GUARD-BOTTLE REF, UP	HIPP, 85MM	2	SR-S2226, S2228/S22NTC, S22DTC
20	DA66-90112A	TRIM-GUARD	PVC, L350, WHT	4	
21	DA71-00090A	GUIDE-BOTTLE, REF	PP, T2.5	1	
22	DA63-00173A	GUARD-BOTTLE REF, LOW	HIPP, 50MM	2	SR-S2026, S2028/S20NTC, S20DTC
	DA63-00172A	GUARD-BOTTLE REF, LOW	HIPP, 85MM	2	SR-S2226, S2228/S22NTC, S22DTC
23	DA61-00108A	SUPPORT-O, RING	SILICON, NTR	2	
24	DA64-00097B	HANDLE-BASE, UP	ABS, SC-97527R	1	"C"-TYPE
25	DA64-00099B	HANDLE-TRIM, LOW	ABS, SC-97527R	1	"
26	DA64-00100A	HANDLE-TRIM, UP	ABS, SC-97527R	1	"
27	DA64-00096B	HANDLE-BASE, MID	ABS, SC-97527R	1	"
28	DA71-00077A	REINF-HANDLE, MID	SBHG1, T1.4	1	"
29	DA64-00095B	HANDLE-BASE, LOW	ABS, SC-97527R	1	"
30	DA71-00078A	REINF-HANDLE, LOW	SBHG1, T1.4	1	"
31	DA64-00098	HANDLE-TRIM, MID	ABS, SC-97527R	1	"
32	DA64-00196A	TRIM-HANDLE CONNECT, MID	ABS, Cr	2	"

14-7) Freezer Room Door Exploded View (SR-S2028, S2029, S2228, S2229/S20DTC, S20FTC, S22DTC, S22FTC)

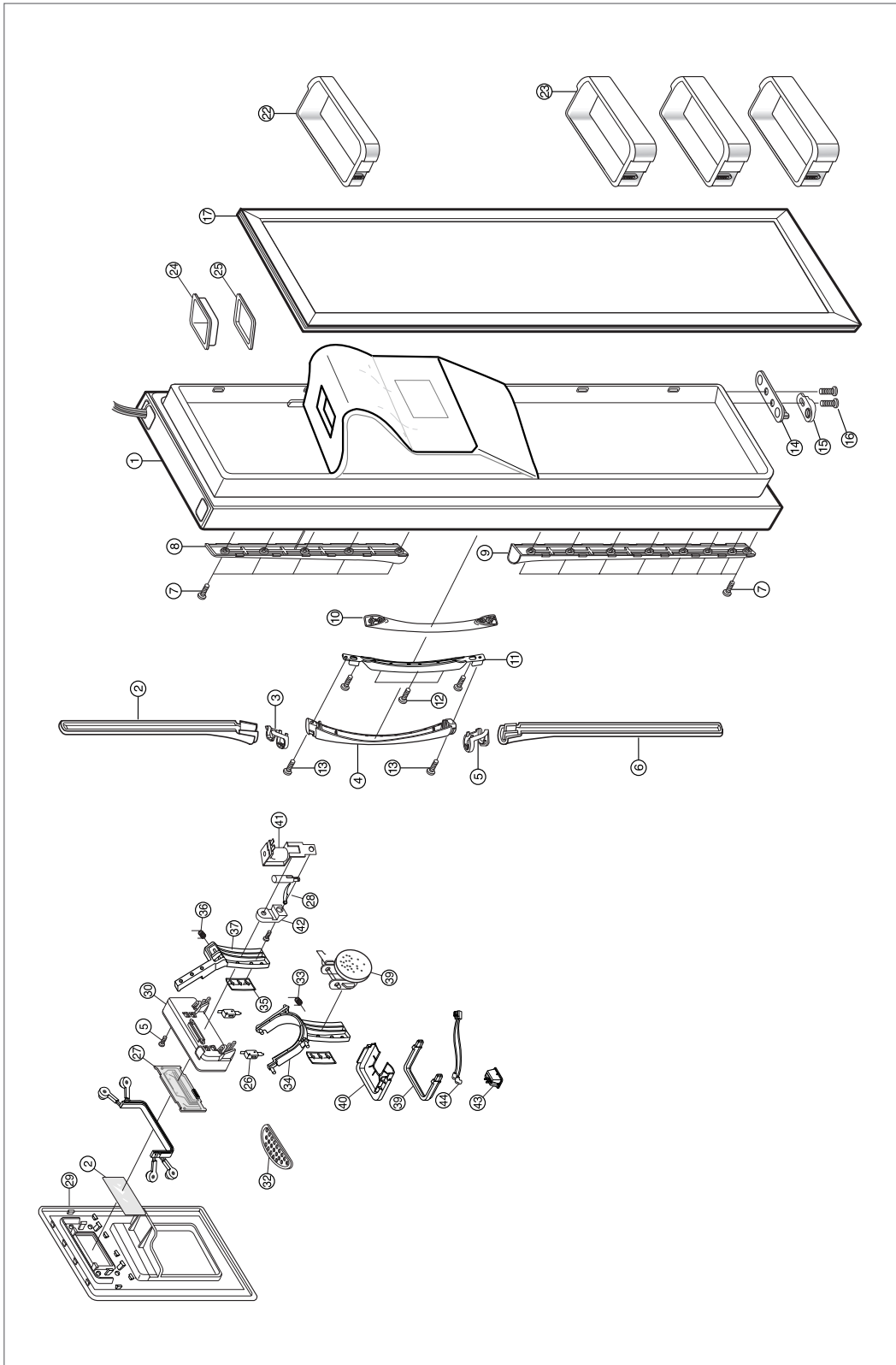

■ Part List of Freezer Room Door Exploded View (SR-S2028, S2029, S2228, S2229/S20DTC,S20FTC,S22DTC,S22FTC)

NO	CODE-NO	Product Name	Specification	Quantity	Remark
1	DA91-00655B	FOAM-DOOR FRE, ASSY	EMBO, SC-97527T S/WHITE, 50MM	1	SR-S2028,S2029,S20DTC,S20FTC
	DA64-00654B	FOAM-DOOR FRE, ASSY	EMBO, SC-97527T S/WHITE, 85MM	1	SR-S2228,S2229,S20DTC,S20FTC
2	DA64-00082B	HANDLE-TRIM, UP	ABS, SC-97527R	1	"D"-TYPE
3	DA64-00176B	TRIM-HANDLE CONNECT, UP	ABS	1	"
4	DA64-00081B	HANDLE-TRIM, MID	ABS, SC-97527R	1	"
5	DA64-00177B	TRIM-HANDLE CONNECT, LOW	ABS	1	"
6	DA64-00083B	HANDLE-TRIM, LOW	ABS, SC-97527R	1	"
7	6002-000458	SCREW-TAPPING	FH-2, M4×14, STS304	13	
8	DA64-00093A	HANDLE-BASE, UP	HIPS	1	"D"-TYPE
9	DA64-00094A	HANDLE-BASE, LOW	HIPS	1	"
10	DA64-00080B	HANDLE	HIPS, SC-97527R	1	"
11	DA71-00056A	REINF-HANDLE, MID	SBHG1, T1.4	1	"
12	6002-000470	SCREW-TAPPING	TH-1, M4×10, ZPC, SWRCH18A	3	
13	6002-000468	SCREW-TAPPING	PH-2S, M5×18, ZPC(YEL)	4	
14	DA71-00068A	STOPPER-DOOR	SHP1, T3, BLK	1	
15	DA66-90112A	CAM-HINGE	POM, G4078B	1	
16	6001-000715	SCREW-MACHINE	TH, M5×16, ZPC(YEL), SWRCH18A	2	
17	DA63-30231G	GASKET-DOOR FRE, ASSY	SF-PVC, MAGNET-85g	1	
18	DA63-00191B	COVER-CONTROL, FRONT	ABS, SC-97527R	1	
19	DA63-00190A	COVER-CONTROL, B	GPPS, T2.5	1	
20	DA41-00020A	PBA-PANEL	T1.6, PANEL PCB ASSY	1	
21	DA64-00089B	KNOB-TOUCH	ABS	1	
22	DA63-00213A	GUARD-BOTTLE FRE, UP	HIPP, 50MM	1	SR-S2028,S2029,S20DTC,S20FTC
	DA63-00214A	GUARD-BOTTLE FRE, UP	HIPP, 85MM	1	SR-S2228,S2229,S20DTC,S20FTC
23	DA63-00169A	GUARD-BOTTLE FRE, LOW	HIPP, 50MM	3	SR-S2028,S2029,S20DTC,S20FTC
	DA63-00169A	GUARD-BOTTLE FRE, LOW	HIPP, 85MM	3	SR-S2228,S2229,S20DTC,S20FTC
24	DA67-00163A	CAP-CHUTE, ICE	ABS, WHT, 50MM	1	
	DA67-00162A	CAP-CHUTE, ICE	ABS, WHT, 85MM	1	
25	DA72-00262A	CUSHION-GUIDE ICE, SHUT	SILICON	1	
26	DA63-00188A	SWITCH-MICRO	VP533-OF-5, MICRO, 250V, 15A	2	
27	DA63-00192A	PBA-PANEL	T1.6 * 190 * 70	1	
28	DA63-00410A	SUPT-TIME,DELAY	HIPS, K2007	1	
29	DA66-00037A	COVER-TRIM,RECESS	ABS, SC-97527,S/WHT	1	
30	DA66-00064A	COVER-PANEL PCB,REAR	PP, T2	1	
31	DA61-00088A	COVER-ICE ROUTE, ASSY	SC-97527,S/WHT	1	
32	DA66-00035A	TRAY-DISPENSER	SC-97527,S/WHT	1	

Indicated part is for electrical safety components

■ Part List of Refrigerator Room (SR-S2028, S2029, S2228, S2229/S20DTC,S20FTC,S22DTC,S22FTC)

NO	CODE-NO	Product Name	Specification	Quantity	Remark
33	DA66-00065A	SPRING-DISP ICE, LEVER	STS304, ϕ 7.2	1	
34	DA61-00086A	LEVER-DISPENSER, ICE	ABS, SC-97527R	1	
35	DA66-00036A	LEVER-DISP, SUB	SILICON,SC-98456R	2	
36	DA71-00073A	SPRING-LEVER DISP, WATER	STS304, ϕ 7.2	1	
37	DA71-00181A	LEVER-DISPENSER,WATER	ABS, SC-97527R	1	
38	DA71-00072A	STOPPER-LEVER	NY-66,T2.0	1	
39	DA97-00283A	GASKET-COVER ICE ROUTE	ABS	1	
40	DA72-00262A	GUIDE-LEVER, SUB	SILICON,SC-97527	1	
41	DA74-10268J	VALVE-SOLENOID	CUBE-SN2,SR-S6586B,220-24	1	
42	DA61-70234A	SUPT-TIME DELAY	HIPS S/WHT	1	
43	3402-000165	SWITCH-DISPENSER	DECO 250VAC 6A	1	
44	DA34-00016A	WIRE-DISPENSER S/W		1	

14-8) Refrigerator Room Door Exploded View (SR-S2027,S2029, S2227,S2229/S20FTC,S22BTC,S22FTC)

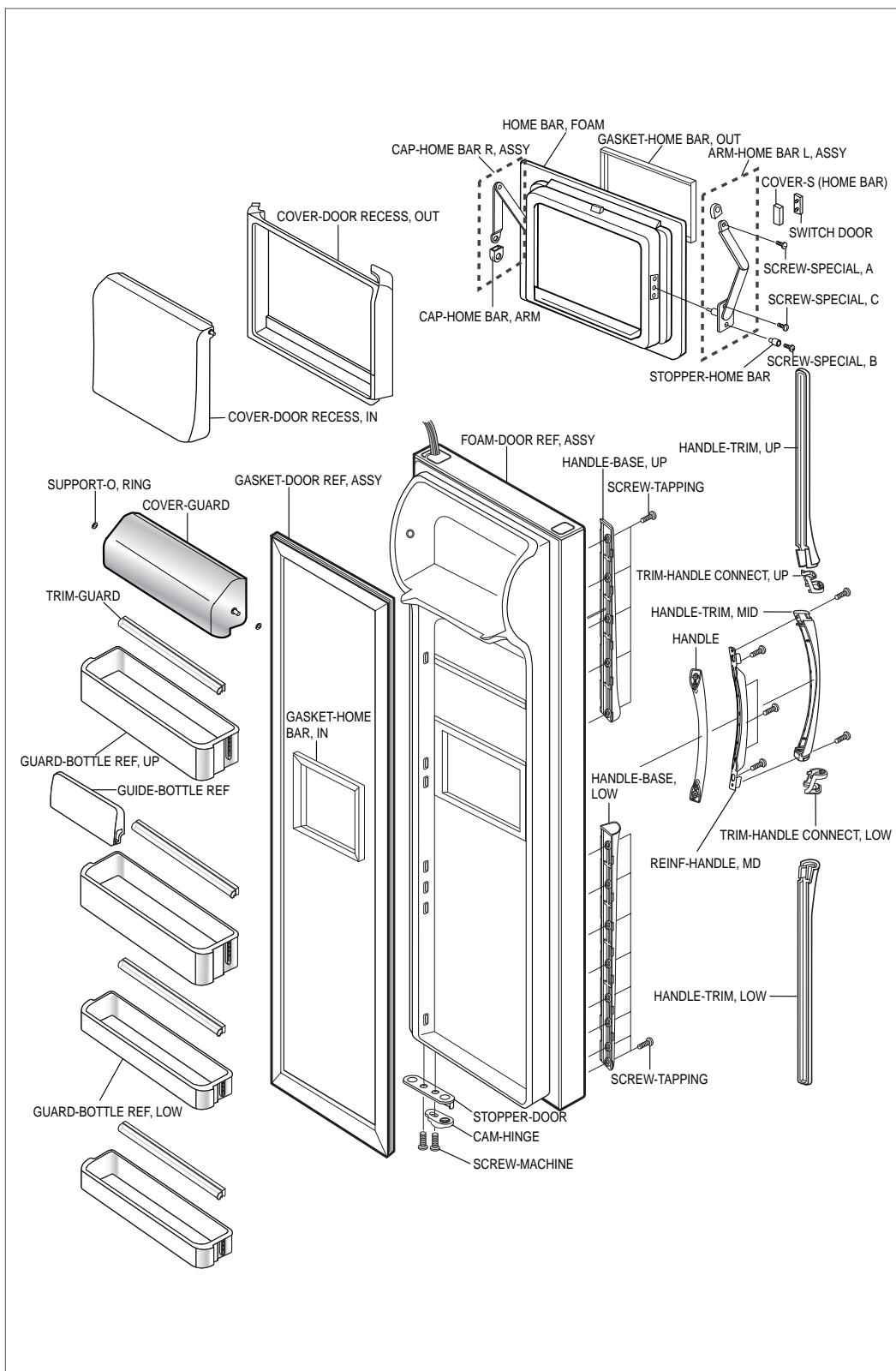

■ Part List of Refrigerator Room Door Exploded View (SR-S2027,S2029, S2227,S2229/S20FTC,S22BTC,S22FTC)

NO	CODE-NO	Product Name	Specification	Quantity	Remark
1	DA91-00659B	FOAM-DOOR REF, ASSY	EMBO, SC-97527T, 50MM	1	SR-S2027,S2029,S20BTC,S20FTC
	DA91-00656B	FOAM-DOOR REF, ASSY	EMBO, SC-97527T, 85MM	1	SR-S2227,S2229,S22BTC,S22FTC
2	DA64-00082B	HANDLE-TRIM, UP	ABS, SC-97527R, S/WHITE	1	"D"-TYPE
3	DA64-00176A	TRIM-HANDLE. CONNECT, UP	ABS, Ni-Cr	1	"
4	DA64-00081B	HANDLE-TRIM, MID	ABS, SC-97527R, S/WHITE	1	"
5	DA64-00177A	TRIM-HANDLE. CONNECT, LOW	ABS, Ni-Cr	1	"
6	DA64-00083B	HANDLE-TRIM, LOW	ABS, SC-97527R, S/WHITE	1	"
7	6002-000458	SCREW-TAPPING	FH, M4×14, STS304	13	
8	DA64-00093A	HANDLE-BASE, UP	HIPS	1	"
9	DA64-00094A	HANDLE-BASE, LOW	HIPS	1	"
10	DA64-00080B	HANDLE	ABS, SC-97527R, S/WHITE	1	"
11	DA71-00056A	REINF-HANDLE, MID	SBHG1, T1.4	1	"
12	6002-000470	SCREW-TAPPING	TH-1, M4×10, ZPC, SCRCH18A	3	
13	6002-000468	SCREW-TAPPING	PH-2S, M5×L18, ZPC(YEL), MAWR	4	
14	DA71-00068A	STOPPER-DOOR	SH-1, T3 BLK	1	
15	DA64-00122A	CAM-HINGE	POM, G4078B	1	
16	6001-000715	SCREW-MACHINE	TH, M5×16, ZPC(YEL), SWRCH18A	2	
17	DA63-30232G	GASKET-DOOR REF, ASSY	SF-PVC, MAGNET-85g	1	
18	DA63-00199A	COVER-GUARD	GPPS, 50MM	1	SR-S2027,S2029,S20BTC,S20FTC
	DA63-00176A	COVER-GUARD	GPPS, 85MM	1	SR-S2227,S2229,S22BTC,S22FTC
19	DA63-00168A	GUARD-BOTTLE REF, UP	HIPP, 50MM	2	SR-S2027,S2029,S20BTC,S20FTC
	DA63-00167A	GUARD-BOTTLE REF, UP	HIPP, 85MM	2	SR-S2227,S2229,S22BTC,S22FTC
20	DA66-90112A	TRIM-GUARD	PVC, L350, WHT	4	
21	DA71-00090A	GUIDE-BOTTLE, REF	PP, T25	1	
	DA63-00173A	GUARD-BOTTLE REF, LOW	HIPP, 50MM	2	SR-S2027,S2029,S20BTC,S20FTC
22	DA63-00172A	GUARD-BOTTLE REF, LOW	HIPP, 85MM	2	SR-S2227,S2229,S22BTC,S22FTC
23	DA61-00108A	SUPPORT-O, RING	SILICON, NTR	2	

Indicated part is for electrical safety components

NO	CODE-NO	Product Name	Specification	Quantity	Remark
24	DA67-00304A	HOME-BAR,FOAM	SC-97527T S/WHITE	1	
25	DA66-00099A	ARM-HOME BAR R,ASSY		1	
25-1	DA67-30271A	CAP-HOME BAR, ARM	NY-60, S/WHITE	2	
26	DA66-00098A	ARM-HOME BAR L,ASSY		1	
27	DA60-10109A	SCREW-SPECIAL,B	STS M7	2	
28	DA60-10110A	SCREW-SPECIAL,C	STS M7	2	
29	DA71-40138A	STOPPER-HOME BAR	NY-66	2	
30	DA60-10108A	SCREW-SPECLAL, A	STS M7	2	
31	DA34-10121A	SWITCH-DOOR	250V 0.5A	1	
32	DA63-10121A	COVER-S/W(HOME BAR)	ABS	1	
33	DA63-00219A	GASKET-HOME BAR, IN	SF-PVC WHITE	1	
34	DA -00225A	GASKET-HOME BAR, OUT	"	1	
35	DA63-00222A	COVER-DOOR RECESS, OUT	GPPS CRISTAL	1	
36	DA63-00223A	COVER-DOOR RECESS,IN	"	1	

14-9) Freezer Room Door Exploded View (SR-S2025/S20YTC)

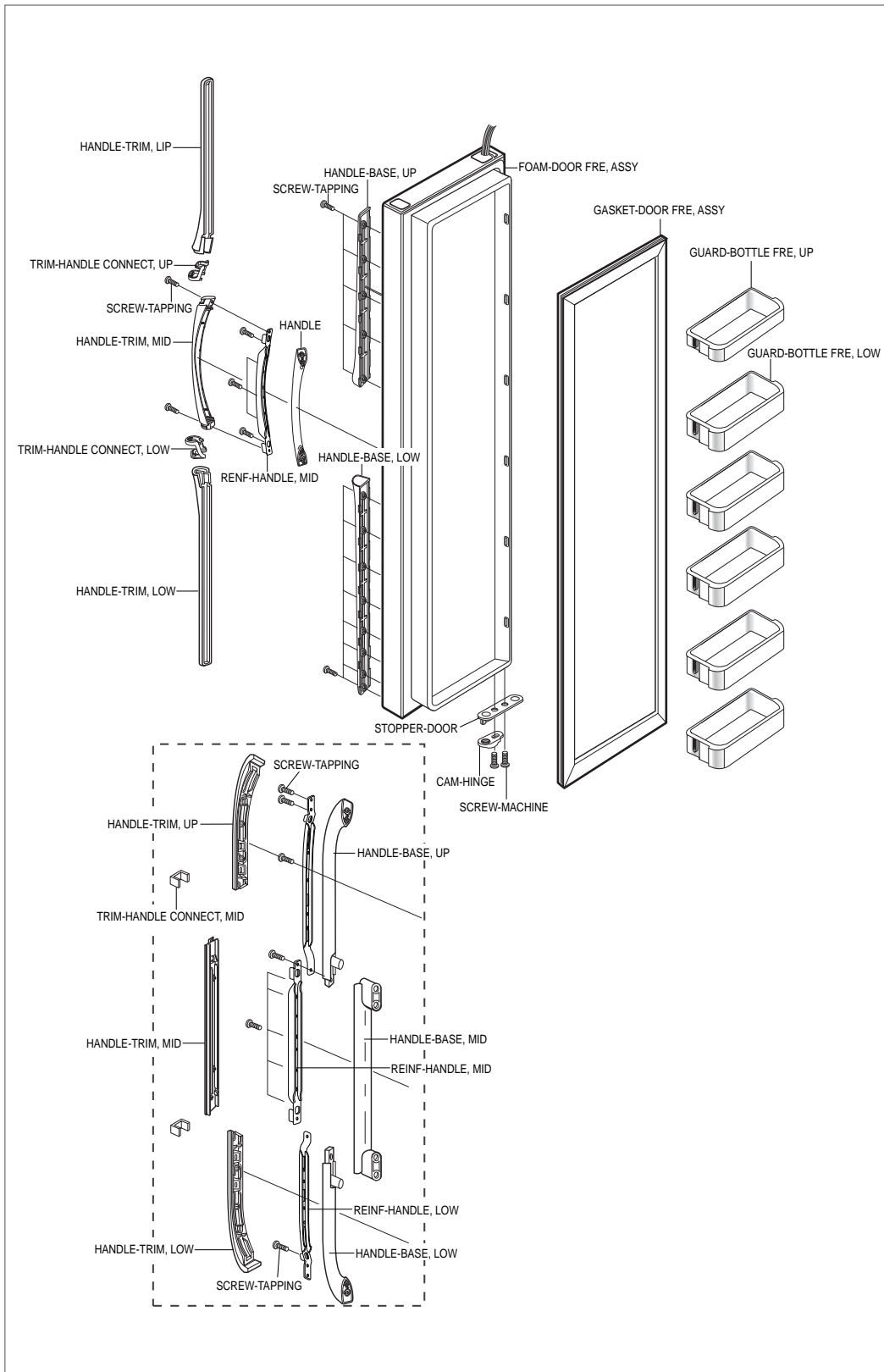

■ Part List of Freezer Room Door Exploded View (SR-S2025/S20YTC)

NO	CODE-NO	Product Name	Specification	Quantity	Remark
1	DA91-01515A	FOAM-DOOR FRE, ASSY	EMBO, SC-97527T S/WHITE, 50MM	1	SR-S2025/SR-S20YTC
2	DA64-00082B	HANDLE-TRIM, UP	ABS, SC-97527R	1	“D”-TYPE
3	DA64-00176B	TRIM-HANDLE CONNECT, UP	ABS	1	“
4	DA64-00081B	HANDLE-TRIM, MID	ABS, SC-97527R	1	“
5	DA64-00177B	TRIM-HANDLE CONNECT, LOW	ABS	1	“
6	DA64-00083B	HANDLE-TRIM, LOW	ABS, SC-97527R	1	“
7	6002-000458	SCREW-TAPPING	FH-2, M4×14, STS304	13	
8	DA64-00093A	HANDLE-BASE, UP	HIPS	1	“D”-TYPE
9	DA64-00094A	HANDLE-BASE, LOW	HIPS	1	“
10	DA64-00080B	HANDLE	HIPS, SC-97527R	1	“
11	DA71-00056A	REINF-HANDLE, MID	SBHG1, T1.4	1	“
12	6002-000470	SCREW-TAPPING	TH-1, M4×10, ZPC, SWRCH18A	3	
13	6002-000468	SCREW-TAPPING	PH-2S, M5×18, ZPC(YEL)	4	
14	DA71-00068A	STOPPER-DOOR	SH-1, T3, BLK	1	
15	DA66-90112A	CAMHINGE	POM, G4078B	1	
16	6001-000715	SCREW-MACHINE	TH, M5×16, ZPC(YEL), SWRCH18A	2	
17	DA63-30231G	GASKET-DOOR FRE, ASSY	SF-PVC, MAGNET-85g	1	
18	DA63-00213A	GUARD-BOTTLE FRE, UP	HIPP, 50MM	1	SR-S2025/SR-S20YTC
19	DA63-00169A	GUARD-BOTTLE, FRE, LOW	HIPP, 50MM	5	
20	DA64-00097B	HANDLE-BASE, UP	GPPS	2	“C”-TYPE
	DA63-01020A	GUARD-VARIETY	ABS, SC-97527R	1	SR-S2025/SR-S20YTC
21	DA64-00099B	HANDLE-TRIM, LOW	ABS, SC-97527R	1	“
22	DA64-00100A	HANDLE-TRIM, UP	ABS, SC-97527R	1	“
23	DA64-00096B	HANDLE-BASE, MID	ABS, SC-97527R	1	“
24	DA71-00077A	REINF-HANDLE, MID	SBHG1, T1.4	1	“
25	DA64-00095B	HANDLE-BASE, LOW	ABS, SC-97527R	1	“
26	DA71-00078A	REINF-HANDLE, LOW	SBHG1, T1.4	1	“
27	DA64-00098	HANDLE-TRIM, MID	ABS, SC-97527R	1	“
28	DA64-00196A	TRIM-HANDLE CONNECT, MID	ABS, Cr	2	“

14-10 Refrigerator Room Door Exploded View (SR-S2025/S20YTC)

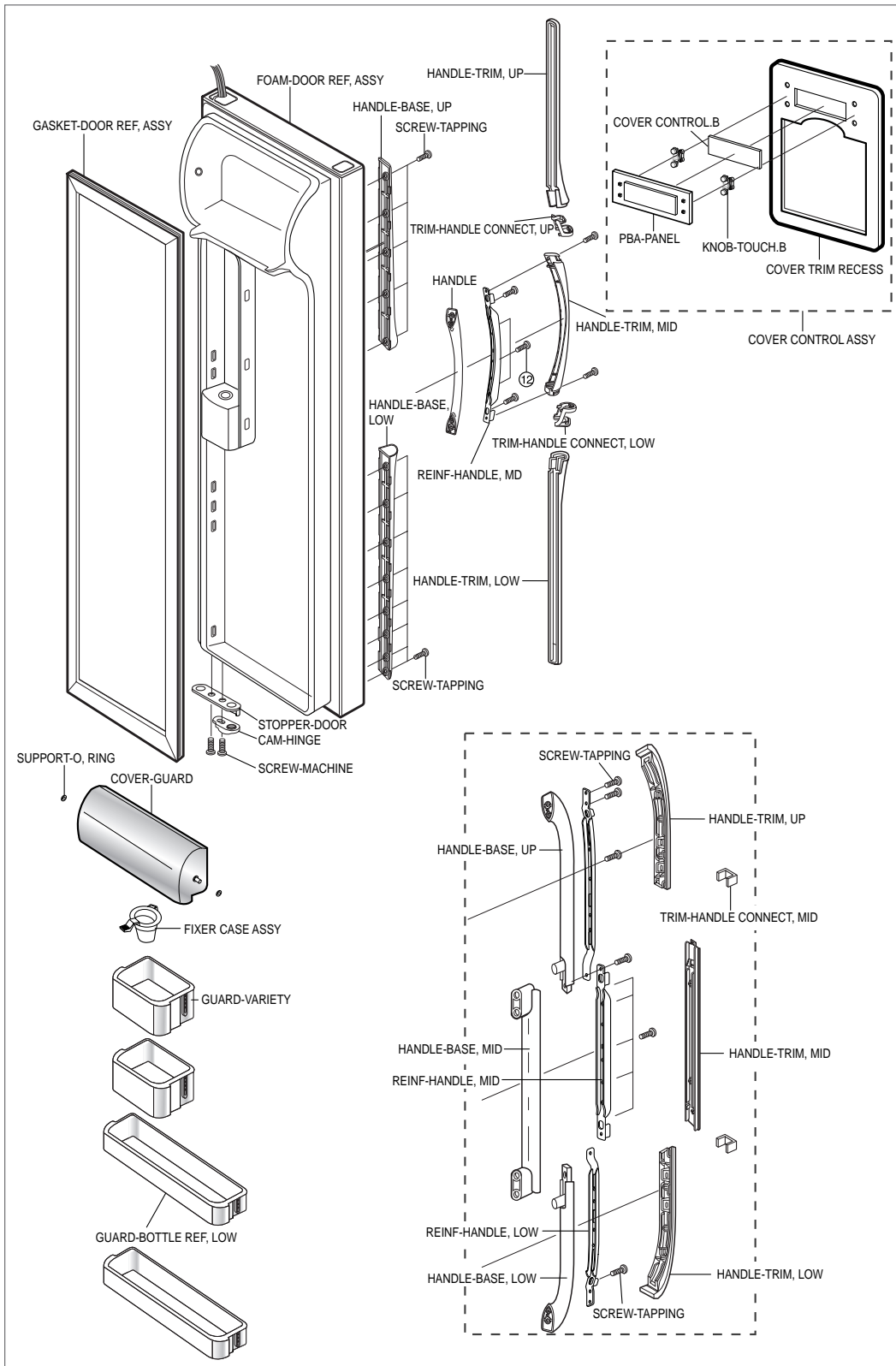

■ Part List of Refrigerator Room Door Exploded View (SR-S2025/S20YTC)

NO	CODE-NO	Product Name	Specification	Quantity	Remark
1	DA91-01514A	FOAM-DOOR REF, ASSY	EMBO, SC-97527T, S/WHITE 50MM	1	SR-S2025/SR-S20YTC
2	DA64-00082B	HANDLE-TRIM, UP	ABS, SC-97527T, S/WHITE	1	"D"-TYPE
3	DA64-00176B	TRIM-HANDLE, CONNECT, UP	ABS	1	"
4	DA64-00081A	HANDLE-TRIM, MID	ABS, SC-97527T, S/WHITE	1	"
5	DA64-00177A	TRIM-HANDLE, CONNECT, LOW	ABS	1	"
6	DA64-00083B	HANDLE-TRIM, LOW	ABS, SC-97527T, S/WHITE	1	"
7	6002-000458	SCREW-TAPPING	FH, M4×14, STS304	13	
8	DA64-00093A	HANDLE-BASE, UP	HIPS	1	"D"-TYPE
9	DA64-00094A	HANDLE-BASE, LOW	HIPS	1	"
10	DA64-00080B	HANDLE	SC-97527T, S/WHITE	1	"
11	DA71-00056A	REINF-HANDLE, MID	SBHG1, T1.4	1	
12	6002-000470	SCREW-TAPPING	TH-1, M4×10, ZPC, SCRCH18A	3	
13	6002-000468	SCREW-TAPPING	PH-2S, M5×L18, ZPC(YEL), MAWR	4	
14	DA71-00068A	STOPPER-DOOR	SH-1, T3 BLK	1	
15	DA64-00122A	CAM-HINGE	POM, G4078B	1	
16	6001-000715	SCREW-MACHINE	TH, M5×16, ZPC(YEL), SWRCH18A	2	
17	DA63-30232G	GASKET-DOOR REF, ASSY	SF-PVC, MAGNET-85g	1	
18	DA63-00199A	COVER-GUARD	GPPS, 50MM	1	SR-S2025/SR-S20YTC
19	DA63-01020A	GUARD-VARIETY	GPPS	2	SR-S2025/SR-S20YTC
20	DA66-90112A	TRIM-GUARD	PVC, L350, WHT	2	
21	DA71-00090A	GUIDE-BOTTLE, REF	PP, T25	1	
22	DA63-00173A	GUARD-BOTTLE REF, LOW	HIPP, 50MM	2	SR-S2025, S2028, S20N7C, S20D7C
23	DA61-00108A	SUPPORT-O, RING	SILICON, NTR	2	
24	DA64-00097B	HANDLE-BASE, UP	ABS, SC-97527R	1	"C"-TYPE
25	DA64-00099B	HANDLE-TRIM, LOW	ABS, SC-97527R	1	"
26	DA64-00100A	HANDLE-TRIM, UP	ABS, SC-97527R	1	"
27	DA64-00096B	HANDLE-BASE, MID	ABS, SC-97527R	1	"
28	DA71-00077A	REINF-HANDLE, MID	SBHG1, T1.4	1	"
29	DA64-00095B	HANDLE-BASE, LOW	ABS, SC-97527R	1	"
30	DA71-00078A	REINF-HANDLE, LOW	SBHG1, T1.4	1	"
31	DA64-00098	HANDLE-TRIM, MID	ABS, SC-97527R	1	"
32	DA64-00196A	TRIM-HANDLE, CONNECT, MID	ABS, Cr	2	"
33	DA71-20155A	FIXER CASE ASSY	ASSY	1	
34	DA97-00099A	COVER-DISPENSER ASSY	ASSY	1	
35	DA63-00999A	COVER-DISPENSER	ABS	1	
36	DA66-00152A	LEVER-DISPENSER	POM	1	
37	DA64-00498A	KNOB-LEVER	ABS	1	
38	DA61-20146A	SPRING-LEVER	STS304	1	
39	DA64-00121A	KEY-LEVER(LOCK)	POM	1	
40	DA63-00998A	TRAY-DISPENSER	ABS	1	

15. Machine Room Assembly Specification

15-1) Please remove fixed screw of cover of machine room of Refrigerator rear low part.

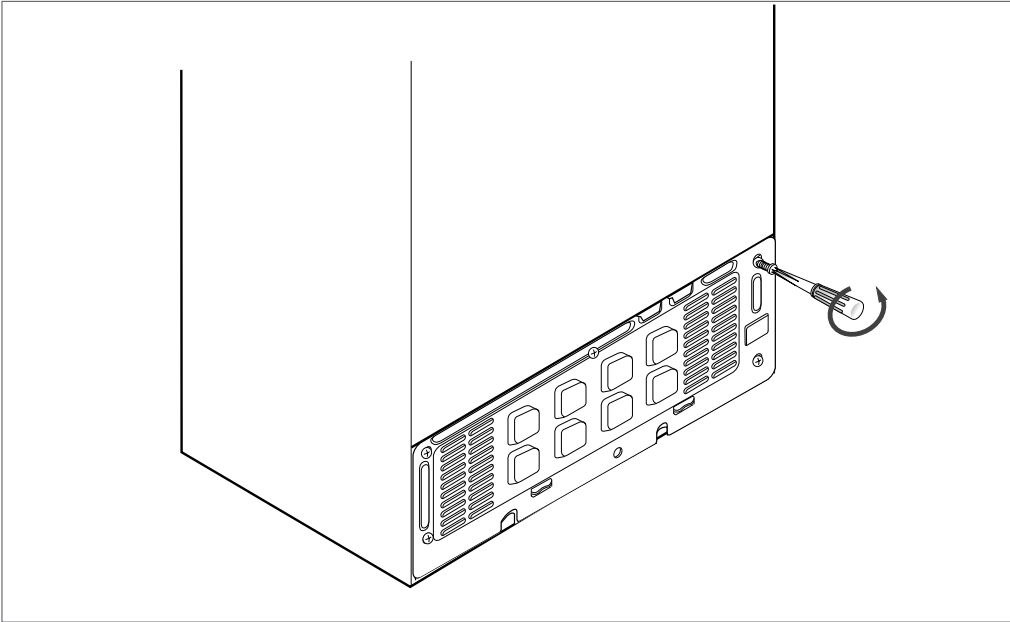

15-2) Machine Room Assembly Specification

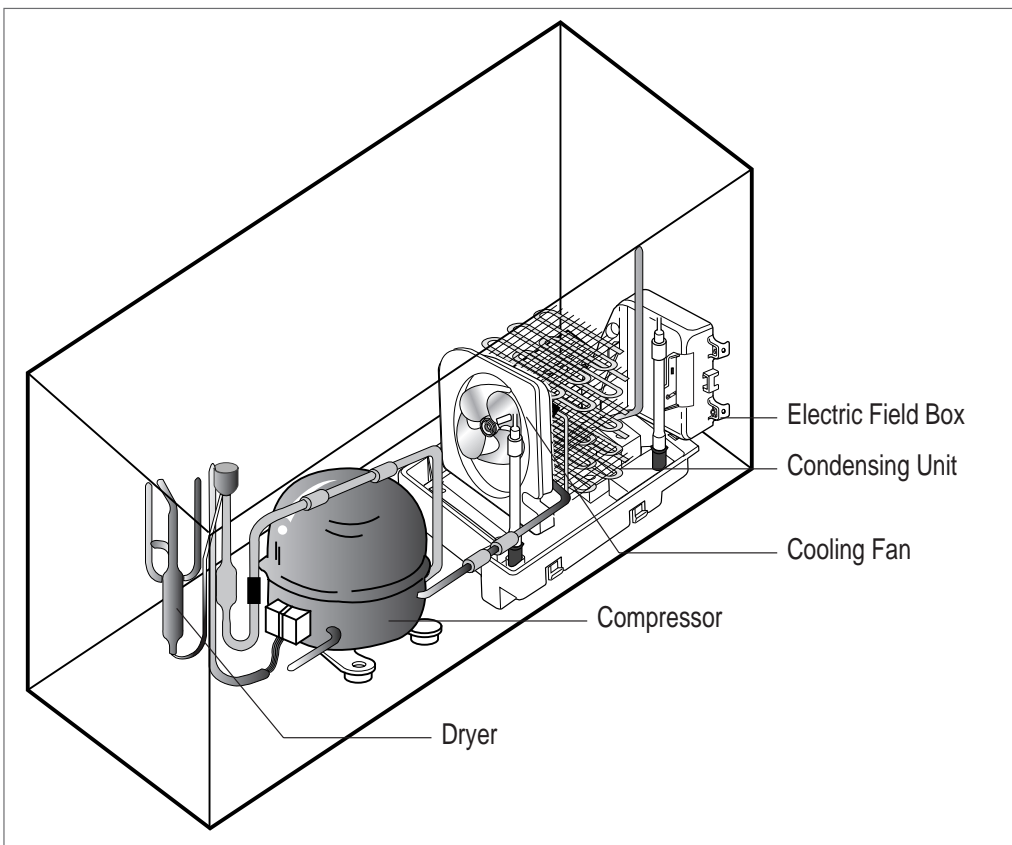

16. Disassembly & Assembly Method of Internal Part of Electric Field Box

16-1) Please cut-off the power supply of refrigerator.

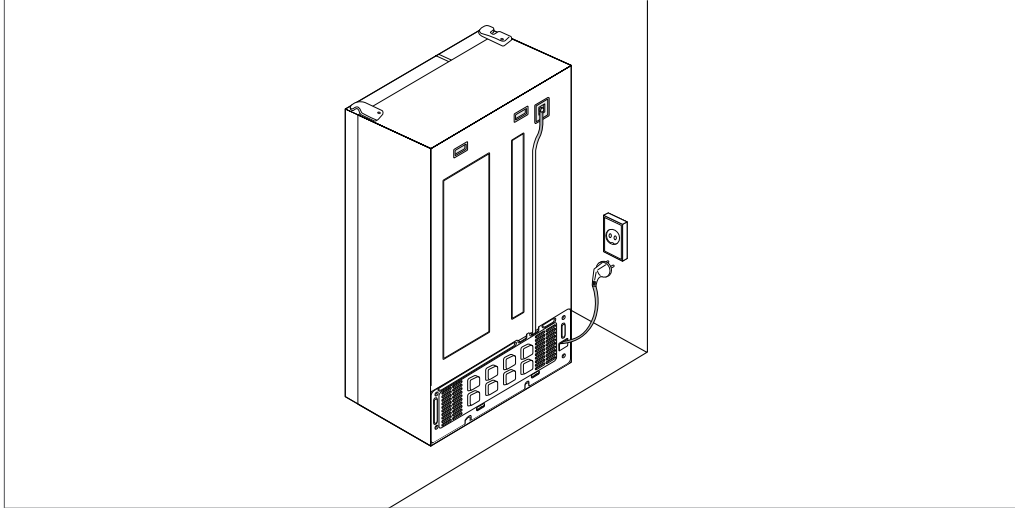

16-2) Please deviate cover of electric field box using driver.

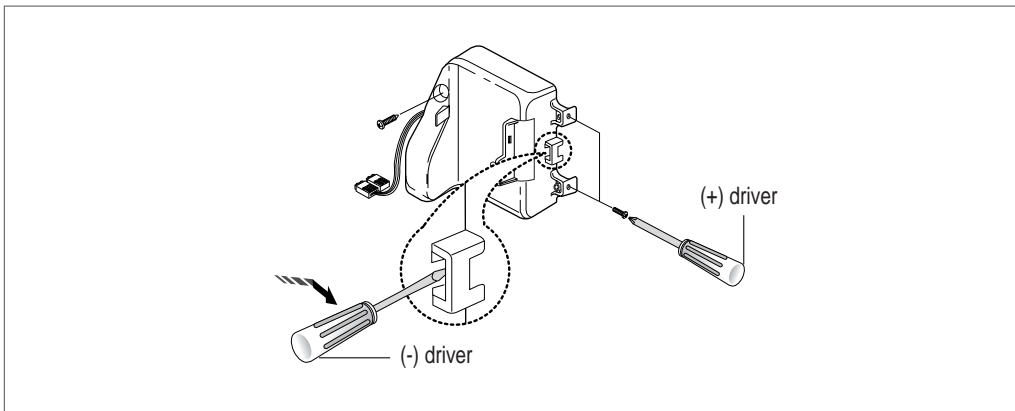

16-3) Assembly Specification of Electric Field Box

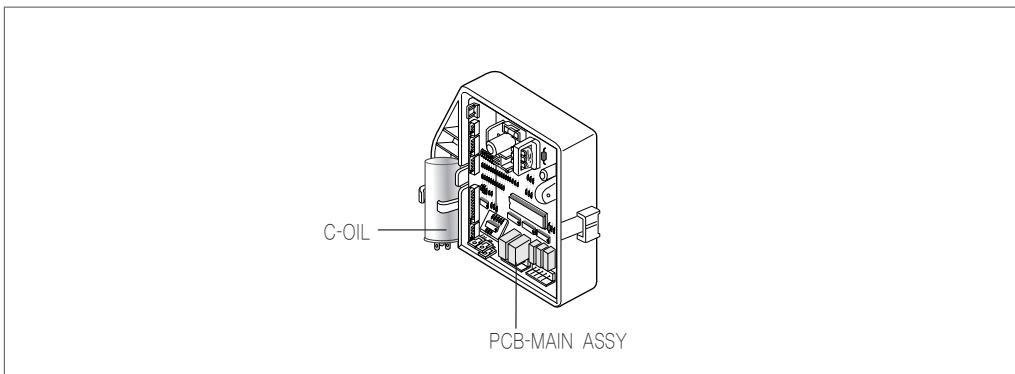

17. Installation Method of Water Supply Tube

10. Check the amount of supplied water to the ice maker.

- 1) Remove the upper ice maker from the refrigerator.

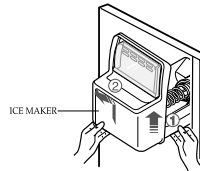

- 2) When the test button is pressed, the ice cube container is turned and then water is out from the tap of the ice maker where water is supplied. At this time, check the amount of water.(see the picture)
If there is over-supply of water, the ice cube will be made in attached form of 2 to 4 ice cubes. If there is less-supply of water, the ice cube will be made in small size. When this happens, you may encounter inconvenience while using. This is not a problem in the refrigerator. It is the problem of water pressure in the water pipe and occurs frequently. When this problem occurs, control the amount of water supply by the following method.

CHECK OF THE SUPPLIED WATER

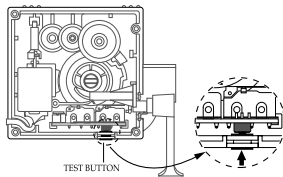
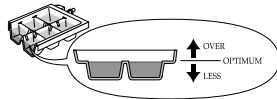
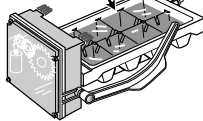

The Method to control the amount of water supply to the ice maker

1. First, change control panel to option change mode.
Press "Freezer Temperature" button and "Vacation" button simultaneously for about 12 seconds, temperature display will change to option change mode with beep
2. The number of right display, refrigerator temperature display, is the kind of option. Press "Refrigerator Temperature" button, the number increases. Also, press "Vacation" button, the number decreases. Set the number to 3.

3. The number of left display, freezer temperature display, is the data of each option. Press "Freezer Temperature" button, the number increases. Also, press "Quick Freeze" button, the number decreases.
Set the number to desired number, two digit, as right table.

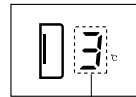

the amount of water

4. Setting the option and data, please wait until control panel is changed to the control mode automatically.

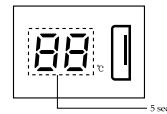

5 sec

Notice

When setting the amount of water supply, do not select the large amount of water supply. Set step-by-step. (Water can be over flowed.)

5. If the option control is completed, check the amount of supplied water in the Ice Maker.

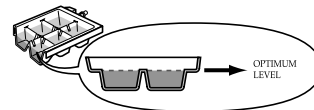

CHECK OF THE SUPPLIED WATER

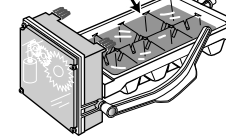

If the controlled amount of water supply is slightly below the optimum level, it is O.K. to use.

	DATA
00	5 Sec
01	4 Sec
02	3 Sec
03	6 Sec
04	7 Sec
05	8 Sec
06	9 Sec
07	10 Sec
08	12 Sec
09	13 Sec
10	15 Sec
11	17 Sec
12	19 Sec
13	21 Sec
14	23 Sec
15	25 Sec

18. Installation of the water dispenser line

- 1) For automatic operation of the ice maker, water pressure of 1.4~4.5 f is required. (It is acceptable if the disposable paper cup(180cc) can be filled up with water within 10 second.)
- 2) The water tube can be used by cutting to the desired length. Make sure that the tube is not bent.
- 3) Make the maximum length of the water tube to be 12m, if possible. If the length is over 12m, it will cause a problem to supply water because of decrease of water pressure.
- 4) Locate the water tube at the area without heat.
- 5) The purifier is just for filtration. It will not work as sterilizer of microorganisms.
- 6) If the refrigerator is installed in the area with low water pressure(below 1.4 f), additionally purchased booster pump may be installed in order to compensate the shortage of pressure.
- 7) The life cycle of purifier depends upon the condition of the usage, but we recommend that you change it every 6 months. So we recommend that you install it at the place to access easily for changing.
- 8) To supply water to the storage tank inside the refrigerator, press the cold water button for about 2 or 3 minutes and make cold water drop from the cold water outlet.
- 9) In order to avoid possible leakage, seal every joined area using sealing tape.
- 10) The water tube should be connected to the cold tap water.

Check the components

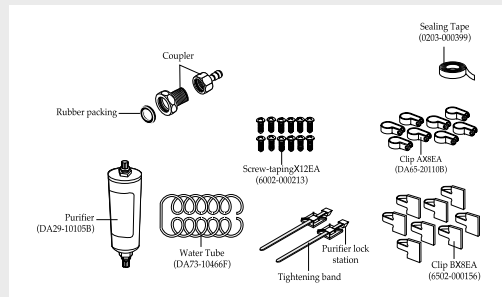

1. Connect coupler to the water tap.

- 1) Close the main water tap.
- 2) Connect the coupler to the tap water.
- 3) Every joint should be taped with sealing tape.(see the picture)

Ⓢ If the coupler doesn't fit to the existing water tap, consult the closest authorized service dealer and purchase the right couplers for the proper installation.

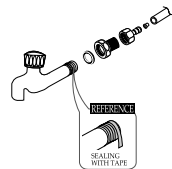

PRECAUTION!

The water tube should be connected to the cold water pipe. If it is connected to the hot water pipe, it may cause some problems in the Functioning of the purifier.

2. Connect the water tube to the coupler

Insert the water tube into the coupler.

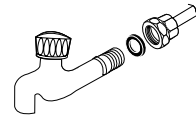

3. Select the purifier location for installation

- 1) Select the location of the purifier.
- 2) Cut water tube considering the distances between Purifier and waterworks tap, and Purifier and water valve of Refrigerator (At this time, it must be cut at a right angle.)
- 3) Insert water tubes of inlet side and outlet side of Purifier.

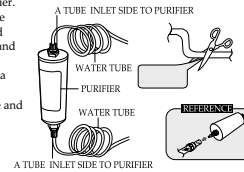

4. Remove the residuals inside the purifiers.

- 1) Open the main water valve to check whether water is running through the water tube from the water inlet side of the purifier.
- 2) Leave the faucet open until clean water is running out.

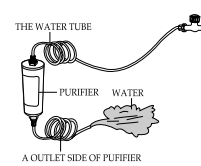

5. Fix the purifier lock station.

- 1) Hold the purifier lock station against the lock hole of right-lower side in the back of the refrigerator and fix it tightly using screw.

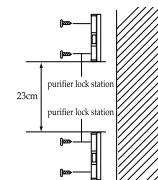

6. Fix the purifier.

- 1) Fix the purifier as shown in the picture on the right.

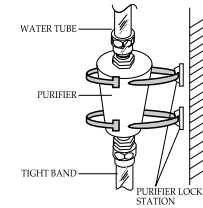

7. Connect the water tube to the refrigerator.

- 1) Remove the back cover of the refrigerator.
- 2) Connect the water tube to the valve as shown in the picture. (The connector is located at right side of the machine room in the back of the refrigerator.)
- 3) When connected, check whether there is any leakage. On leakage, reassemble them.

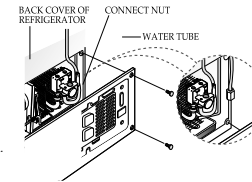

8. Put the water tube in order

- 1) Using the clip "A" and "B" fix the water tube to the wall.
- 2) When the water tube is put in order, make sure there are any forced bending and pushing against the water tube.

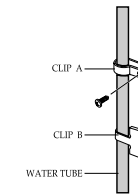

9. Complete the installation of the water dispenser line

- 1) Turn on the refrigerator and press the left side lever until water is coming out through the water tube. (approximately 2~3minute) (Press it until the initial air outing phenomenon disappear.)
- 2) At this time, check any possible leakage on the joints of the water tube. After putting the water tube in order, move the refrigerator to the desired location. Once the refrigerator is located, do not move the refrigerator as possible.

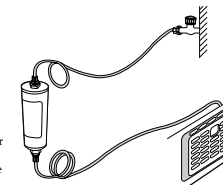

19. PCB circuit diagram and Service Components LIST

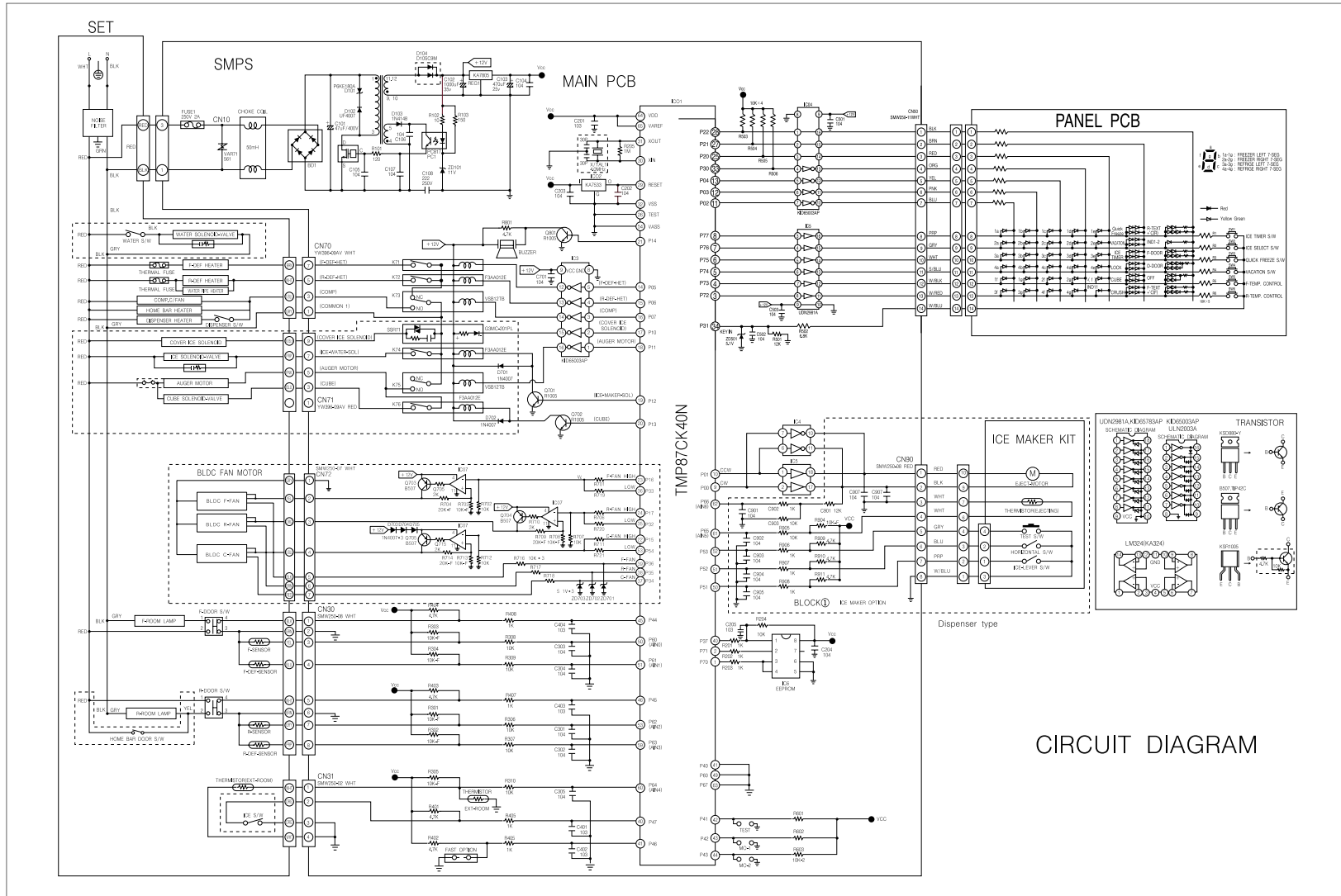

CIRCUIT DIAGRAM

20. Specification of Principal Part of Circuit

20-1) REGULATOR

3-TERMINAL 1A POSITIVE VOLTAGE REGULATORS

The KA78XX series of three-terminal positive regulators are available in the TO-220 package and with several fixed output voltages, making them useful in a wide range of applications. Each type employs internal current limiting, thermal shut-down and safe area protection, making it essentially indestructible. If adequate heat sinking is provided, they can deliver over 1A output current. Although designed primarily as fixed voltage regulators, these devices can be used with external components to obtain adjustable voltages and currents.

TO-220

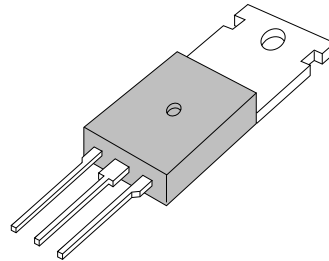

1:Input 2:GND 3:Output

■ FEATURES

- Output Current up to 1A
- Output Voltages of 5; 6; 8; 9; 10; 11; 12; 15; 18; 24V
- Thermal Overload Protection
- Short Circuit Protection
- Output Transistor SOA Protection

■ ORDERING INFORMATION

Device	Package	Operating Temperature
KA78XX	TO-220	0 ~ +125°C
KA78XXA	TO-220	
KA78XXI	TO-220	-40 ~ +125°C

■ BLOCK DIAGRAM

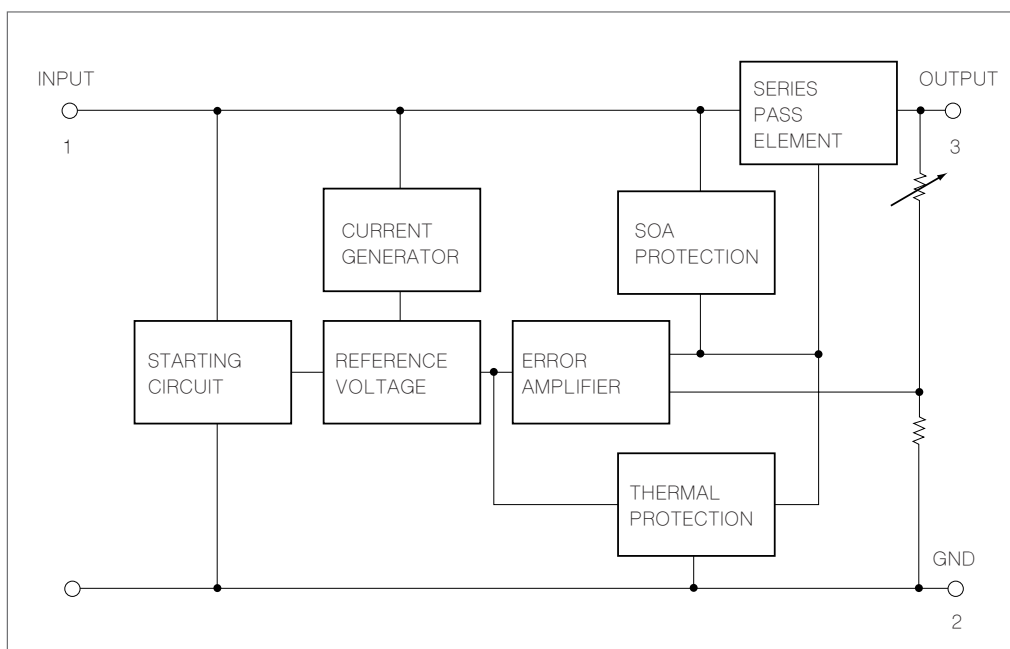

ABSOLUTE MAXIMUM RATINGS (T_A = 25°C unless otherwise specified)

Characteristic	Symbol	Value	Unit
Input Voltage (for V _o = 5V to 18V) (for V _o = 24V)	V _i	35	V
	V _i	40	V
Thermal Resistance Junction-Cases	R _{eJC}	5	°C/W
Thermal Resistance Junction-Air	R _{eJA}	65	°C/W
Operating Junction Temperature Range KA78XX/A KA78XXI	T _{OPR}	0 ~ +125	°C
		-40 ~ +125	°C
Storage Temperature Range	T _{STG}	-65 ~ +150	°C

ELECTRICAL CHARACTERISTICS KA7805/I

(Refer to test circuit, T_{MIN} < T_J < T_{MAX}, I_o = 500mA, V_i = 10V, C_i = 0.33μF, C_o = 0.1μF, unless otherwise specified)

Characteristic	Symbol	Test Conditions	KA78051			KA7805			Unit
			Min	Typ	Max	Min	Typ	Max	
Output Voltage	V _o	T _J = 25°C	4.8	5.0	5.2	4.8	5.0	5.2	V
		5.0mA ≤ I _o ≤ 1.0A, P _o ≤ 15W							
		V _i = 7V to 20V V _i = 8V to 20V	4.75	5.0	5.25	4.75	5.0	5.25	
Line Regulation	ΔV _o	T _J = 25°C	V _i = 7V to 25V	4.0	100	4.0	100	mV	
			V _i = 8V to 12V	1.6	50	1.6	50		
Load Regulation	ΔV _o	T _J = 25°C	I _o = 0.5mA to 1.5A	9	100	9	100	mV	
			I _o = 250mA to 750mA	4	50	4	50		
Quiescent Current	I _o	T _J = 25°C	5.0	8	5.0	8	mA		
Quiescent Current Change	ΔI _o	I _o = 5mA to 1.0A	0.03	0.5	0.03	0.5	mA		
		V _i = 7V to 25V			0.3	1.3			
		V _i = 8V to 25V	0.3	1.3					
Output Voltage Drift	ΔV _o /ΔT	I _o = 5mA	-0.8		-0.8		mV/°C		
Output Noise Voltage	V _N	f = 10Hz to 100KHz T _A = 25°C	42		42		μV		
Ripple Rejection	RR	f = 120Hz V _i = 8 to 18V	62	73	62	73	dB		
Dropout Voltage	V _o	I _o = 1A, T _J = 25°C	2		2		V		
Output Resistance	R _o	f = 1KHz	15		15		mΩ		
Short Circuit Current	I _{sc}	V _i = 35V, T _A = 25°C	230		230		mA		
Peak Current	I _{PK}	T _J = 25°C	2.2		2.2		A		

* T_{MIN} < T_J < T_{MAX}

KA78XXI : T_{MIN} = -40°C, T_{MAX} = 125°C

KA78XX, T_{MIN} = 0°C, T_{MAX} = 125°C

* Load and line regulation are specified at constant junction temperature.

Changes in V_o due to heating effects must be taken into account separately.

Pulse testing with low duty is used.

ABSOLUTE MAXIMUM RATINGS (T_A = 25°C unless otherwise specified)

Characteristic	Symbol	Value	Unit
Input Voltage (for V _o = 5V to 18V)	V _i	35	V
(for V _o = 24V)	V _i	40	V
Thermal Resistance Junction-Cases	R _{eJC}	5	°C/W
Thermal Resistance Junction-Air	R _{eJA}	65	°C/W
Operating Junction Temperature Range KA78XX/A	T _{OPR}	0 ~ +125	°C
KA78XXI		-40 ~ +125	°C
Storage Temperature Range	T _{STG}	-65 ~ +150	°C

ELECTRICAL CHARACTERISTICS KA7805/I

(Refer to test circuit, T_{MIN} < T_J < T_{MAX}, I_o = 500mA, V_i = 10V, C_i = 0.33μF, C_o = 0.1μF, unless otherwise specified)

Characteristic	Symbol	Test Conditions	KA78051			KA7805			Unit
			Min	Typ	Max	Min	Typ	Max	
Output Voltage	V _o	T _J = 25°C	4.8	5.0	5.2	4.8	5.0	5.2	V _o
		5.0mA ≤ I _o ≤ 1.0A, P _o ≤ 15W				4.75	5.0	5.25	
		V _i = 7V to 20V V _i = 8V to 20V	4.75	5.0	5.25				
Line Regulation	ΔV _o	T _J = 25°C	V _i = 7V to 25V	4.0	100	4.0	100	ΔV _o	
			V _i = 8V to 12V	1.6	50	1.6	50		
Load Regulation	ΔV _o	T _J = 25°C	I _o = 0.5mA to 1.5A	9	100	9	100	ΔV _o	
			I _o = 250mA to 750mA	4	50	4	50		
Quiescent Current	I _o	T _J = 25°C	5.0	8	5.0	8	I _o		
Quiescent Current Change	ΔI _o	I _o = 5mA to 1.0A	V _i = 7V to 25V			0.3	1.3	ΔI _o	
			V _i = 8V to 25V	0.3	1.3				
Output Voltage Drift	ΔV _o /ΔT	I _o = 5mA	-0.8		-0.8		ΔV _o /ΔT		
Output Noise Voltage	V _N	f = 10Hz to 100KHz T _A = 25°C	42		42		V _N		
Ripple Rejection	RR	f = 120Hz V _i = 8 to 18V	62	73	62	73	RR		
Dropout Voltage	V _o	I _o = 1A, T _J = 25°C	2		2		V _o		
Output Resistance	R _o	f = 1KHz	15		15		R _o		
Short Circuit Current	I _{SC}	V _i = 35V, T _A = 25°C	230		230		I _{SC}		
Peak Current	V _{PK}	T _J = 25°C	2.2		2.2		V _{PK}		

* T_{MIN} < T_J < T_{MAX}

KA78XXI : T_{MIN} = -40°C, T_{MAX} = 125°C

KA78XX, T_{MIN} = 0°C, T_{MAX} = 125°C

* Load and line regulation are specified at constant junction temperature.

Changes in V_o due to heating effects must be taken into account separately.

Pulse testing with low duty is used.

ELECTRICAL CHARACTERISTICS KA7812/I

(Refer to test circuit, $T_{MIN} < T_J < T_{MAX}$, $I_o = 500mA$, $V_i = 19V$, $C_i = 0.33\mu F$, $C_o = 0.1\mu F$, unless otherwise specified)

Characteristic	Symbol	Test Conditions	KA7812I			KA7812I			Unit
			Min	Typ	Max	Min	Typ	Max	
Output Voltage	V_o	$T_J = 25^\circ C$	11.5	12	12.5	11.5	12	12.5	V
		$5.0mA \leq I_o \leq 1.0A$, $P_o \leq 15W$							
		$V_i = 14.5V$ to $27V$ $V_i = 15.5V$ to $27V$	11.4	12	12.6	11.4	12	12.6	
Line Regulation	ΔV_o	$T_J = 25^\circ C$	$V_i = 14.5$ to $30V$	10	240	10	240	mV	
			$V_i = 16$ to $22V$	3.0	120	3.0	120		
Load Regulation	ΔV_o	$T_J = 25^\circ C$	$I_o = 5mA$ to $1.5A$	11	240	11	240	mV	
			$I_o = 250mA$ to $750mA$	5.0	120	5.0	120		
Quiescent Current	I_o	$T_J = 25^\circ C$	5.1	8	5.1	8	mA		
Quiescent Current Change	ΔI_o		$I_o = 5mA$ to $1.0A$	0.1	0.5	0.1	0.5	mA	
			$V_i = 14.5V$ to $30V$			0.5	1.0		
			$V_i = 15V$ to $30V$	0.5	1.0				
Output Voltage Drift	$\Delta V_o / \Delta T$	$I_o = 5mA$	-1		-1		mV/°C		
Output Noise Voltage	V_N	$f = 10Hz$ to $100KHz$, $T_A = 25^\circ C$	76		76		μV		
Ripple Rejection	RR	$f = 120Hz$ $V_i = 15V$ to $25V$	55	71	55	71	dB		
Dropout Voltage	V_o	$I_o = 1A$, $T_J = 25^\circ C$	2		2		V		
Output Resistance	R_o	$f = 1KHz$	18		18		m Ω		
Short Circuit Current	I_{SC}	$V_i = 35V$, $T_A = 25^\circ C$	230		230		mA		
Peak Current	V_{PK}	$T_J = 25^\circ C$	2.2		2.2		A		

* $T_{MIN} < T_J < T_{MAX}$

KA78XXI : $T_{MIN} = -40^\circ C$, $T_{MAX} = 125^\circ C$

KA78XX, $T_{MIN} = 0^\circ C$, $T_{MAX} = 125^\circ C$

* Load and line regulation are specified at constant junction temperature.

Changes in V_o due to heating effects must be taken into account separately.

Pulse testing with low duty is used.

20-2) RESET IC (KA7533)

3.3V VOLTAGE DETECTOR

The KA7533 prevents error of system from supply voltage below normal voltage level at the time the power on and instantaneous power off in systems.

■ FEATURES

- Detecting against error operations at the power ON/OFF.
- Resetting function for the low voltage microprocessor.
- Checking low battery.

TO-92

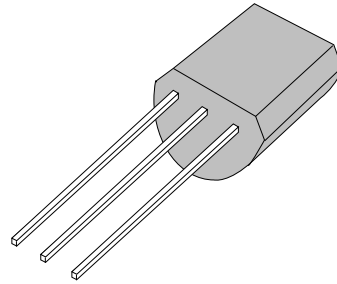

1:Input 2:GND 3:Output

■ ORDERING INFORMATION

Device	Package	Operating Temperature
KA7533Z	TO-92	-30 ~ +75°C

■ BLOCK DIAGRAM

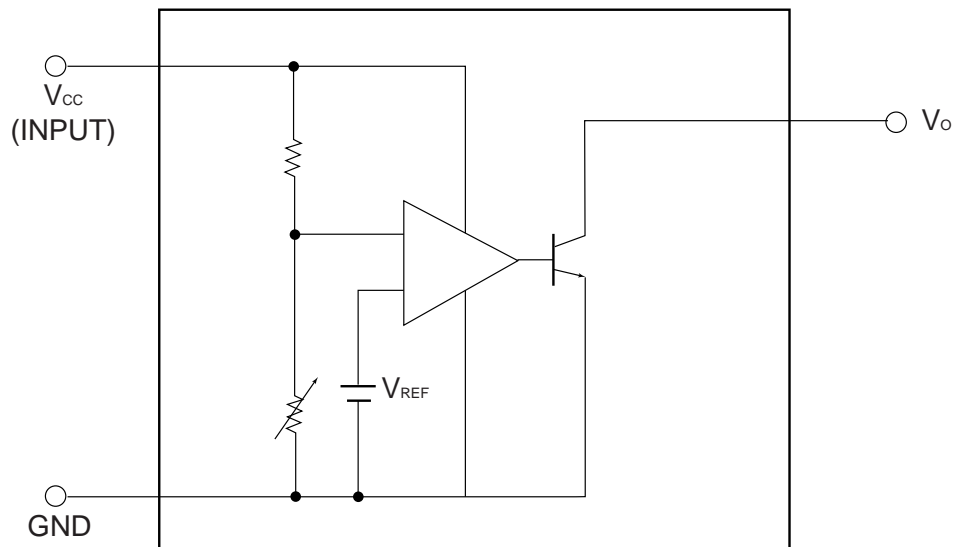

■ ABSOLUTE MAXIMUM RATING (T_A = 25°C)

Characteristic	Symbol	Value	Unit
Supply Voltage	V _{CC}	-0.3 ~ +15.0	V
Detecting Voltage	V _{DET}	3.3	V
Hysteresis Voltage	R _{HYS}	50	mV
Operating Temperature	T _{OPR}	-30 ~ +75	°C
Storage Temperature	T _{STG}	-50 ~ +150	°C
Power Dissipation	P _D	200	mW
Detecting Voltage Temperature Coefficient	ΔV _{DET} /ΔT	±0.01	%/°C

■ ELECTRICAL CHARACTERISTICS (T_A = 25°C)

Characteristic	Symbol	Test Conditions	Min	Typ	Max	Unit
Detecting Voltage	V _{DET}	R _L = 200 Ω, V _{OL} ≤ 0.4V	3.15	3.3	3.45	V
Low Output Voltage	V _{OL}	R _L = 200 Ω	-	-	0.25	V
Output Leakage Current	I _{LKG}	V _{CC} = 15V	-	-	0.1	μV
Hysteresis Voltage	V _{HYS}	R _L = 200 Ω	30	50	100	mV
Detecting Voltage Temperature Coefficient	ΔV _{DET} /ΔT	R _L = 200 Ω		±0.1		%/°C
Circuit Current (at on time)	I _{CCL}	V _{CC} = V _{DET(MIN)} - 0.05V	-	300	500	μA
Circuit Current (at off time)	I _{CCH}	V _{CC} = 5.25V	-	30	50	μA
Threshold Operating Voltage	V _{TH(OPR)}	R _L = 200 Ω, V _{OL} ≤ 0.4V	0.6	0.8	1.0	V
“L” Transmission Delay Time	T _{DL}	R _L = 1.0 kΩ, C _L = 100pF	-	10	15	μS
“H” Transmission Delay Time	T _{DM}	R _L = 1.0 kΩ, C _L = 100pF	-	15	20	μS
Output Current (at on time I)	T _{OL I}	V _{CC} = V _{DET(MIN)} - 0.05V, T _C = 25°C	10	18	28	mA
Output Current (at on time II)	T _{OL II}	V _{CC} = V _{DET(MIN)} - 0.05V, T _C = -30 ~ +75°C	8	16	30	mA

20-3) DRIVER IC (KID65783AP)

KEC
KOREA ELECTRONICS CO.,LTD.

SEMICONDUCTOR
TECHNICAL DATA

KID65783AP/AF
BIPOLAR LINEAR INTEGRATED CIRCUIT

8CH HIGH-VOLTAGE SOURCE DRIVER

The KID65783AP/AF is comprised of eight source current transistor array.
This driver is specifically designed for fluorescent display applications.
Applications include relay, hammer and lamp drivers.

FEATURES

- High Output Voltage : $V_{CC}=50V(\text{Min.})$.
- Output Current (Single Output) $I_{OUT} : -500\text{mA}(\text{MIN})$
- Output Clamp Diodes.
- Single Supply Voltage.
- Input Compatible With Various Types of Logic.
- Package Type-AP : DIP-18pin.
- Package Type AF : FLP-18pin.

TYPE	DESIGNATION
KID65783AP/AF	TTL, 5V CMOS

■ PIN CONNEASTION (TOP VIEW)

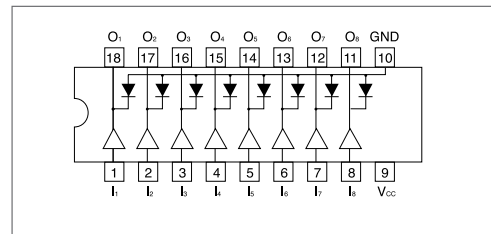

■ SCHEMATICS (EACH DRIVER)

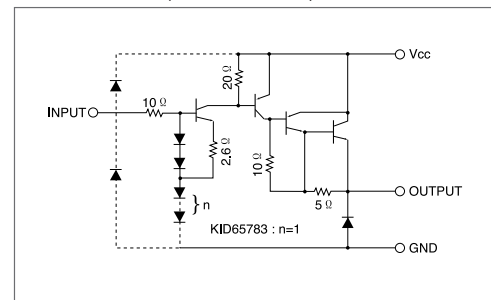

(Note) The input and output parasitic diodes cannot be used as clamp diodes.

MAXIMUM RATINGS ($T_a=25^\circ\text{C}$)

CHARACTIC	SYMBOL	RATING	UNIT
Supply Voltage	V_{CC}	50	V
Output Current	I_{OUT}	-500	mA/ch
Input Voltage	V_{IN}	15	V
Clamp Diode Reverse Voltage	V_R	50	V
Clamp Diode Forward Current	I_F	500	mA
Power Dissipation	AP	1.47	W
	AF	0.96	
Operating Temperature	T_{OPT}	-40~85	$^\circ\text{C}$
Storage Temperature	T_{STG}	-55~150	$^\circ\text{C}$

■ ELECTRICAL CHARACTERISTICS ($T_a=25^\circ\text{C}, V_{CC}=5V$)

CHARACTERISTIC	SYMBOL	TEST CIRCUIT	TEST CONDITION	MIN.	TYP.	MAX.	UNIT
Output Leakage Curret	I_{CEX}	1	$V_{CC} = V_{CC \text{ MAX.}}, V_{IN} = 0.4V, T_a = 25^\circ\text{C}$	-	-	100	μA
Output Saturation Voltage	$V_{CE(\text{sat})}$	2	$V_{IN} = V_{IN(\text{ON})}, I_{OUT} = -350\text{mA}$	-	-	2.0	V
			$V_{IN} = V_{IN(\text{ON})}, I_{OUT} = -225\text{mA}$	-	-	1.9	
			$V_{IN} = V_{IN(\text{ON})}, I_{OUT} = -100\text{mA}$	-	-	1.8	
Input Current	$I_{IN(\text{ON})}$	3	$V_{IN} = 2.4V$	-	36	52	μA
			$V_{IN} = 3.85V$	-	180	260	
Input Voltage	$I_{IN(\text{ON})}$	4	$V_{CE} = 2.0V, I_{OUT} = 1350\text{mA}$	-	-	2.0	V
	$I_{IN(\text{OFF})}$		$I_{OUT} = -500\mu\text{A}$	0.8	-	-	
Supply Current	$I_{IN(\text{ON})}$	3	$V_{IN} = V_{IN(\text{ON})}, V_{CC} = 50V$	-	-	2.5	mA/ch
Clamp Diode Reverse Current	I_R	5	$V_R = 50V$	-	-	50	μA
Clamp Diode Forward Voltage	V_F	6	$I_F = 350\text{mA}$	-	-	2.0	V
Turn-On Delay	t_{ON}	7	$V_{CC} = V_{CC \text{ MAX.}}, R_L = 125 \Omega, C_L = 15\text{pF}$	-	0.15	-	μs
Turn-Off Delay	t_{OFF}			-	1.8	-	

2001 THRU 2024

HIGH-VOLTAGE, HIGH-CURRENT DARLINGTON ARRAYS

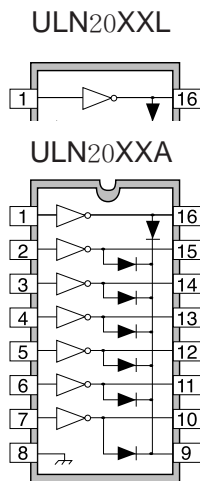

Dwg. No. A-9594

ABSOLUTE MAXIMUM RATINGS

Output Voltage, V_{CE} (ULN200X*, ULN2013A)	50V
(ULN202X*)	95V
Input Voltage V_{IN}	30V
Continuous Output Current, I_C (ULN200X*, ULN202X*) ...	500mA
(ULN2013A)	600mA
Continuous Input Current, I_{IN} ...	25mA
Power Dissipation, P_D (one Darlington pair)	1.0W
(total package)	See Graph
Operating Temperature Range, T_A	-20°C to +85°C
Storage Temperature Range, T_S	-55°C to +150°C

Note that the ULN2000A Series (dual in-line package) and ULN2000L series (small-outline IC package) are electrically identical and share a common pin number assignment.

Ideally suited for interfacing between low-level logic circuitry and multiple peripheral power loads, the Series ULN2000A/L high-voltage, high-current Darlington arrays feature continuous load current ratings to 600 mA for each of the seven drivers. At an appropriate duty cycle depending on ambient temperature and number of drivers turned ON simultaneously, typical power loads totaling over 260W(400mA × 7, 95V) can be controlled. Typical loads include relays, solenoids, stepping motors, magnetic print hammers, multiplexed LED and incandescent displays, and heaters. All devices feature open collector outputs with integral clamp diodes.

The ULN2001A device is a general-purpose array that may be used with external input current limiting, or with most PMOS or CMOS logic directly.

The Series ULN20 × 3A/L has series input resistors selected for operation directly with 5V TTL or CMOS. These devices will handle numerous interface needs-particularly those beyond the capabilities of standard logic buffers.

The Series ULN20 × 4A/L features series input resistors for operation directly from 6 to 15V CMOS or PMOS logic outputs.

The Series ULN20 × A/L is the standard Darlington array. The outputs are capable of sinking 500mA and will withstand at least 50V in the OFF state. Outputs may be paralleled for higher load current capability. The ULN2013A device is similar except that it will sink 600mA. The Series ULN202 × A/L will withstand 95V in the OFF state.

These Darlington arrays are furnished in 16-pin dual in-line plastic packages (suffix A) and 16-lead surface-mountable SOICs (suffix L). All devices are pinned with outputs opposite inputs to facilitate ease of circuit board layout.

■ FEATURES

- TTL, DTL, PMOS, or CMOS Compatible inputs
- Output Current to 600mA
- Output Voltage to 95V
- Transient-Protected Outputs
- Dual In-Line Plastic Package or Small-Outline IC Package

x = digit to identify specific device. Characteristic shown applies to family of devices with remaining digits as shown. See matrix on next page.

2001 THRU 2024 HIGH-VOLTAGE, HIGH-CURRENT DARLINGTON ARRAYS

PARTIAL SCHEMATICS

ULN2001A (Each Driver)

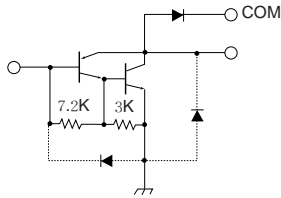

Dwg. No. A-9595

ULN20X3A/L (Each Driver)

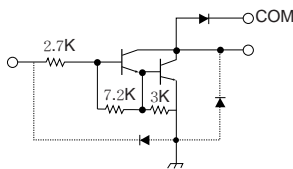

Dwg. No. A-9651

ULN20X4A/L (Each Driver)

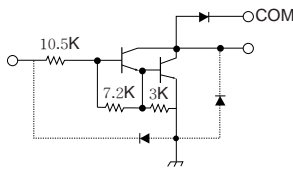

Dwg. No. A-9898A

■ DEVICE NUMBER DESIGNATION

$V_{CE(MAX)}$	50V	50V	95V
$I_C(MAX)$	500mA	600mA	500mA

Logic

Part Number

General Purpose			
PMOS, CMOS	ULN2001A*	-	-
5V	ULN2003A*		ULN2023A*
TTL, CMOS	ULN2003L*	ULN2013A*	ULN2023L
6-15V	ULN2004A*		
CMOS, PMOS	ULN2004L*	-	ULN2024A

*Also available for operation between -40°C and $+85^{\circ}\text{C}$.

To order, change prefix from 'ULN' to 'ULQ'.

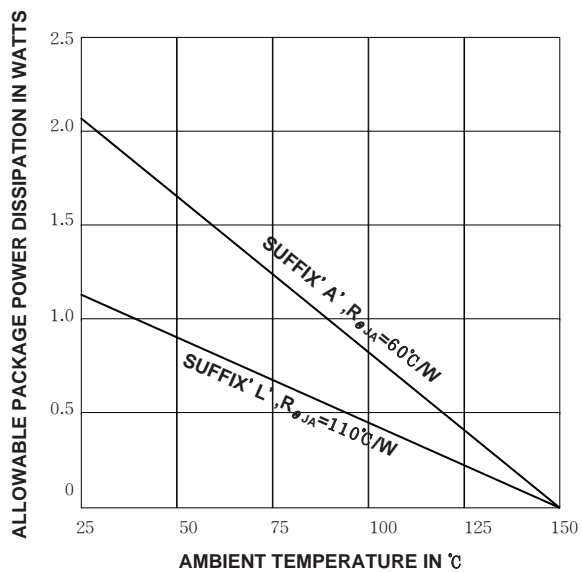

Dwg. No. GP-006

x = Digit to identify specific device. Specification shown applies to family of devices with remaining digits as shown. See matrix above.

20-5) RELAY (VSB-12TB)

VSB Relay

16 Amps. Miniature Slim Type Power Relay

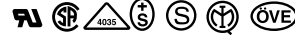

■ FEATURES

- All or Nothing Relay
- UL, CSA, VDE, SEV, SEMKO, IMQ, ÖVE, BSI Recognized
- Working Class : C
- Type of Service : Continuous Duty
- Heavy Duty 16A Miniature Power Relay
- UL Class B(130°C) Insulation
 - Insulation Distance : 8mm
 - Dielectric Strength : 5,000VAC
(between coil and contacts)
 - Surge Strength : 10,000V
- Low Power Consumption and high Sensitive Type Available (VSB-S)
- Washable (With Tape) Type Available

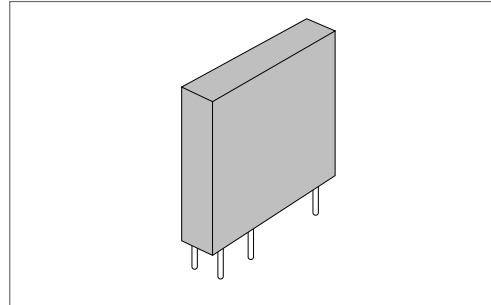

■ STRUCTURE

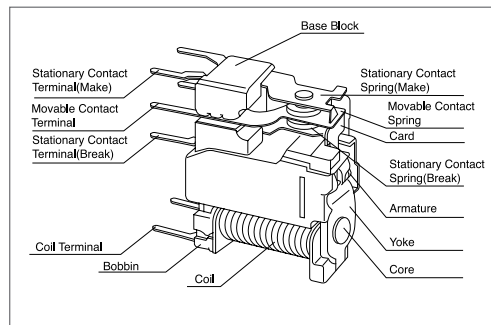

■ SPECIFICATIONS

CONTACT

- Arrangement 1 Form A (SPST-NO) or
1 Form C (SPDT)
- Material Silver alloy
- Type Single Type
- Resistance (initial) Max. 200mΩ (at 6VDC 1A)
- Ratings (resistive)
 - Nominal Load 16A 250VAC or 30VDC
 - Max. Switching Power 4,000VA, 480W
 - Max. Switching Voltage 380VAC, 150VDC
 - Max. Switching Current 16A
 - Max. Carrying Current 16A
 - Max. Switching Load(*1) 5VDC 100mA
- Life Expectancy
 - Mechanical 5×10^6 operations
 - Electrical 1×10^6 operations (at nominal load)

COIL

- Nominal Voltage 3 to 100VDC
- Nominal Power (at 20°C) Standard Type : 0.70 to 0.75W
High sensitive Type : 0.53W
- Operate Power (at 20°C) Standard Type : 0.35 to 0.37W
High sensitive Type : 0.26W
- Operate & Release Voltage Please see Coil Data Chart
- Max. Continuous Voltage Please see Characteristic Data

GENERAL

- Insulation Resistance Min. 1,000MΩ at 500VDC
- Dielectric Strength 1,000VAC 1 minute
IMQ \leq (between open contacts)
5,000VAC 1 minute
(between coil and contacts)
- Surge Strength 10,000V
IMQ ∇ (at $1.2 \times 50\mu$ s standard surge wave)
- Temperature Range Standard Type : -30°C to +65°C
(at nominal Voltage) High sensitive Type : -30°C to +75°C
- Time Value Operate Max. 20ms
(at nominal voltage) Release Max. 10ms
- Vibration Resistance
 - Misoperation 10 to 55 Hz,
double amplitude of 1.5mm
 - Endurance 10 to 55 Hz,
double amplitude of 1.5mm
- Shock Resistance
 - Misoperation 100 m/s² (11 ± 1ms)
 - Endurance 1,000 m/s² (6 ± 1ms)
- Unit Weight Approx. 18g
- Enclosure Polybutylene Terephthalate(PBT)

(*1) Min. Switching Load mentioned above are reference values. Please perform the confirmation test with the actual load before production since reference values may vary according to switching frequencies, environmental conditions and expected reliability levels.

■ VSB Relay

■ SAFETY STANDARD & FILE NUMBERS

UL 508 (File No. E56140. E108658)
C22.2 No.0, No.14 (File No. LR35579)
VDE 0435, 0631, 0700

Please be noted that UL/CSA rating may differ from the Standard ratings.

Please request when the approval markings are required on the cover.

Relay type	Nominal coil Voltage	contact ratings
VSB	3 to 100VDC	1/3HP 125VAC/250VAC
		16A 30VDC/250VAC, Resistive Pilot duty C 150

■ ORDERING INFORMATION

V S B - 1 2 S T B

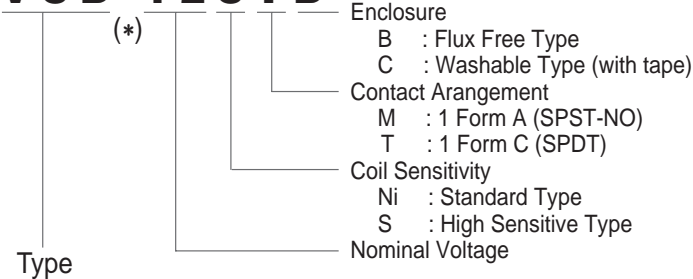

Note) 1. Actual making omits the hyphen (-) of (*)

■ COIL DATA CHART

	ORDERING CODE	Coil Nominal Voltage V DC	Coil Resistance $\Omega \pm 10\%$ (at 20°C)	Must Operate Voltage V DC (at 20°C)	Must Release Voltage V DC (at 20°C)	Coil Nominal Power W (at 20°C)
Standard Type	VSB - 3() ()	3	12.5	2.1	0.3	0.72
	VSB - 5() ()	5	36	3.5	0.5	0.70
	VSB - 6() ()	6	50	3.5	0.5	0.72
	VSB - 9() ()	9	115	6.3	0.9	0.70
	VSB - 12() ()	12	200	8.4	1.2	0.72
	VSB - 14() ()	14	280	9.8	1.4	0.70
	VSB - 18() ()	18	460	12.6	1.8	0.70
	VSB - 24() ()	24	820	16.8	2.4	0.70
	VSB - 36() ()	36	1,850	25.2	3.6	0.70
	VSB - 48() ()	48	3,300	33.6	4.8	0.70
	VSB - 60() ()	60	5,100	42.0	6.0	0.70
VSB - 100() ()	100	13,400	70.0	10.0	0.75	
High Sensitive Type	VSB - 3S() ()	3	17	2.1	0.3	0.53
	VSB - 5S() ()	5	47	3.5	0.5	0.53
	VSB - 6S() ()	6	68	4.2	0.6	0.53
	VSB - 9S() ()	9	155	6.3	0.9	0.53
	VSB - 12S() ()	12	270	8.4	1.2	0.53
	VSB - 14S() ()	14	370	9.8	1.4	0.53
	VSB - 18S() ()	18	610	12.6	1.8	0.53
	VSB - 24S() ()	24	1,100	16.8	2.4	0.53
	VSB - 36S() ()	36	2,450	25.2	3.6	0.53
	VSB - 48S() ()	48	4,400	33.6	4.8	0.53
	VSB - 60S() ()	60	6,800	42.0	6.0	0.53
VSB - 100S() ()	100	18,860	70.0	10.0	0.53	

Safety Instruction on Service

- Unplug the refrigerator before making any repair or any replacement.
 - ⇒ Avoid the electric shock.
- Use the rated components on the replacement.
 - ⇒ Check the correct model, rated voltage, rated current, operating temperature and so on.
- On repair, be sure that the wires such as harness are bundled tightly and are not permeated by water...
 - ⇒ Bundle wires tightly in order not to be detached by the external force.
- On repair, remove completely dust, particles or other things on housing parts, harness parts, and check parts.
 - ⇒ Cleaning may prevent fire by tracking or short.
- Check if there is any trace indicating the permeation of water.
 - ⇒ If there is that kind of trace, change the related components or do the necessary measure such as taping using the insulating tape.
- After repair, check the assembled state of parts.
 - ⇒ It must be in the same assembled state when compared with the state before disassembly.
- Check the surrounding conditions of the installed refrigerator.
 - ⇒ When the refrigerator is located at humid or wet place, or the installed state is unstable, change the location.
- If needed, do the grounding
 - ⇒ Especially, if there is a possibility of the electric leakage, this appliance must be properly grounded.
- Do not allow consumers to use one consent for several plugs.
- Check whether the power cord is placed under other appliance and so, damaged, frayed squeezed.
 - ⇒ Repair immediately the defective power plug or consent.
 - ⇒ Make sure that the power cord does not come to be placed under other appliance or squeezed.
- Do not allow consumers to keep bottles or the likes in the Freezer Room or to keep foods in unstable state.
- Do not allow consumers to repair the appliance for themselves.
- Do not allow consumers to keep other things except food.
 - ⇒ Medicines and other materials for research : this appliance will not maintain the strictly controlled condition.
 - ⇒ Volatile material(alcohol, benzene, ether, LP gas etc.) : possibility of explosion

MEMO

A large, empty rectangular box with rounded corners, intended for writing a memo. The box is white with a thin black border and occupies most of the page below the header.

MEMO

A large, empty rectangular box with rounded corners, intended for writing a memo. The box is defined by a thin black border and occupies the majority of the page below the header.



272, Oseon-Dong, Kwangsan-Gu,
Kwangju-City, Korea, 506-253
TEL : 82-62-950-6810, 6811
FAX : 82-62-950-6829