

IMPORTANT SERVICE GUIDE

◆ MODE SWITCH (PROGRAM SWITCH) ASSEMBLY POINT

1) When installing the ass'y deck on the Main PCB, be sure to align the assembly point of mode switch.

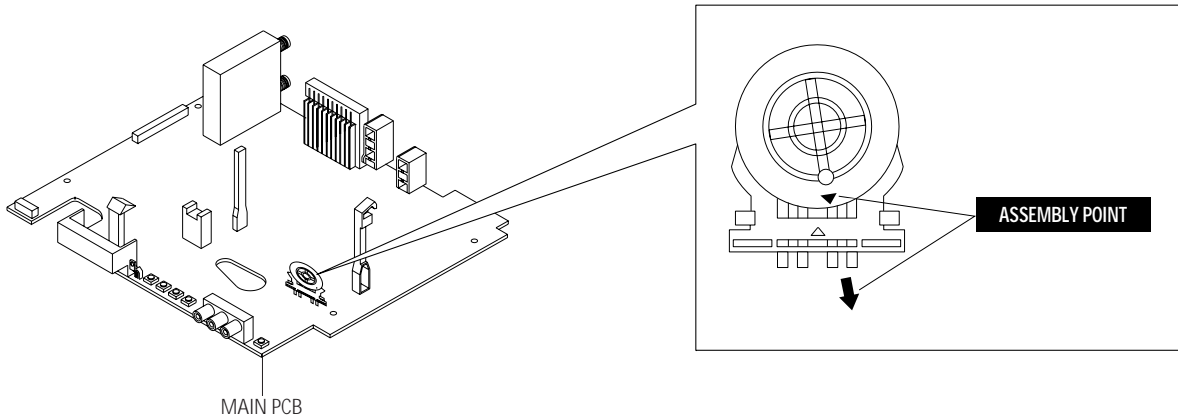

Fig. 1

◆ HOW TO EJECT THE CASSETTE TAPE (If the tape is stuck in the unit)

- 1) Turn the Gear Worm ❶ clockwise in the direction of arrow with screwdriver. (See Fig. 2)
(Other method ; Remove the screw of Motor Load Ass'y, Separate the Motor Load Ass'y)
- 2) When Slider S, T are approach the unloading position, rotate holder Clutch counterclockwise after inserting screwdriver in the frame's bottom hole in order to wind the unwound tape. (Refer to Fig. 3)
(If you rotate Gear Worm ❶ continuously when tape is in state of unwinding, you may cause tape contamination by grease and tape damage. Be sure to wind the unwound tape in the state of set horizontally.)
- 3) Rotate Gear Worm ❶ clockwise using screw driver again up to the state of eject mode and then pick out the tape. (Refer to Fig. 2)

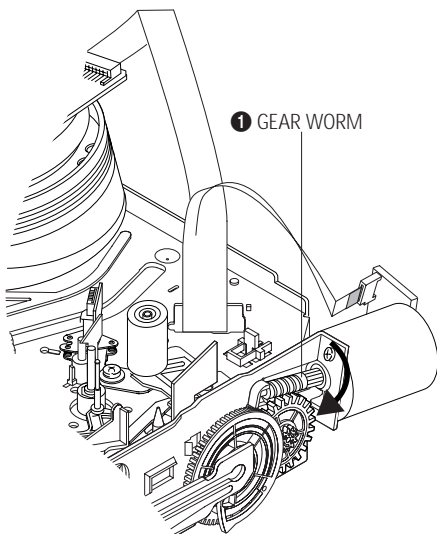

Fig. 2

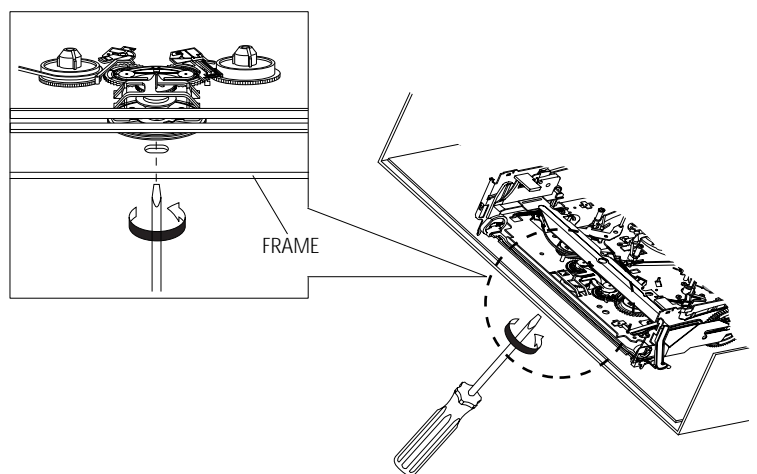

Fig. 3

1. Precautions

1-1 Safety Precautions

1) Before returning an instrument to the customer, always make a safety check of the entire instrument, including, but not limited to, the following items:

(1) Be sure that no built-in protective devices are defective or have been defeated during servicing. (1) Protective shields are provided to protect both the technician and the customer. Correctly replace all missing protective shields, including any removed for servicing convenience.

(2) When reinstalling the chassis and/or other assembly in the cabinet, be sure to put back in place all protective devices, including, but not limited to, nonmetallic control knobs, insulating fish papers, adjustment and compartment covers/shields, and isolation resistor/capacitor networks. Do not operate this instrument or permit it to be operated without all protective devices correctly installed and functioning.

(2) Be sure that there are no cabinet openings through which adults or children might be able to insert their fingers and contact a hazardous voltage. Such openings include, but are not limited to, excessively wide cabinet ventilation slots, and an improperly fitted and/or incorrectly secured cabinet back cover.

(3) Leakage Current Hot Check-With the instrument completely reassembled, plug the AC line cord directly into a 120V AC outlet. (Do not use an isolation transformer during this test.) Use a leakage current tester or a metering system that complies with American National Standards Institute (ANSI) C101.1 Leakage Current for Appliances and Underwriters Laboratories (UL) 1270 (40.7). With the instrument's AC switch first in the ON position and then in the OFF position, measure from a known earth ground (metal water pipe, conduit, etc.) to all exposed metal parts of the instrument (antennas, handle brackets, metal cabinets, screwheads, metallic overlays, control shafts, etc.), especially any exposed metal parts that offer an electrical return path to the chassis.

Any current measured must not exceed 0.5mA. Reverse the instrument power cord plug in the outlet and repeat the test. See Fig. 1-1.

Any measurements not within the limits specified herein indicate a potential shock hazard that must be eliminated before returning the instrument to the customer.

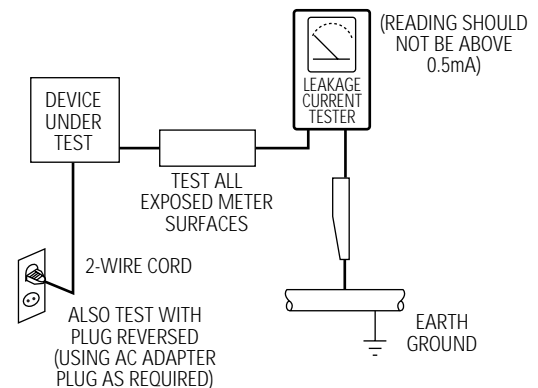

Fig. 1-1 AC Leakage Test

(4) Insulation Resistance Test Cold Check-(1) Unplug the power supply cord and connect a jumper wire between the two prongs of the plug. (2) Turn on the power switch of the instrument. (3) Measure the resistance with an ohmmeter between the jumpered AC plug and all exposed metallic cabinet parts on the instrument, such as screwheads, antenna, control shafts, handle brackets, etc. When an exposed metallic part has a return path to the chassis, the reading should be between 1 and 5.2 megohm. When there is no return path to the chassis, the reading must be infinite. If the reading is not within the limits specified, there is the possibility of a shock hazard, and the instrument must be repaired and rechecked before it is returned to the customer. See Fig. 1-2.

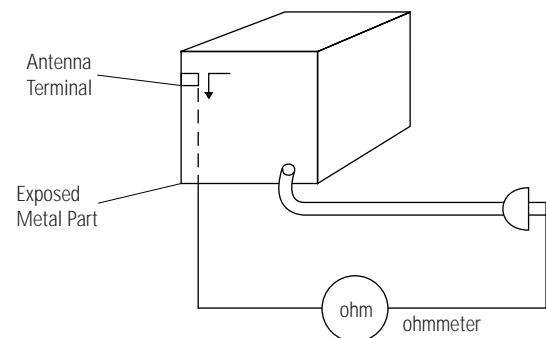



Fig. 1-2 Insulation Resistance Test

- 2) Read and comply with all caution and safety related notes on or inside the cabinet, or on the chassis.
- 3) Design Alteration Warning-Do not alter or add to the mechanical or electrical design of this instrument. Design alterations and additions, including but not limited to, circuit modifications and the addition of items such as auxiliary audio output connections, might alter the safety characteristics of this instrument and create a hazard to the user. Any design alterations or additions will make you, the servicer, responsible for personal injury or property damage resulting therefrom.
- 4) Observe original lead dress. Take extra care to assure correct lead dress in the following areas:
 - (1) near sharp edges, (2) near thermally hot parts (be sure that leads and components do not touch thermally hot parts), (3) the AC supply, (4) high voltage, and (5) antenna wiring. Always inspect in all areas for pinched, out-of-place, or frayed wiring. Do not change spacing between a component and the printed-circuit board. Check the AC power cord for damage.
- 5) Components, parts, and/or wiring that appear to have overheated or that are otherwise damaged should be replaced with components, parts and/or wiring that meet original specifications. Additionally, determine the cause of overheating and/or damage and, if necessary, take corrective action to remove any potential safety hazard.
- 6) Product Safety Notice-Some electrical and mechanical parts have special safety-related characteristics which are often not evident from visual inspection, nor can the protection they give necessarily be obtained by replacing them with components rated for higher voltage, wattage, etc. Parts that have special safety characteristics are identified by shading, an () or a () on schematics and parts lists. Use of a substitute replacement that does not have the same safety characteristics as the recommended replacement part might create shock, fire and/or other hazards. Product safety is under review continuously and new instructions are issued whenever appropriate.

1-2 Servicing Precautions

CAUTION : Before servicing units covered by this service manual and its supplements, read and follow the Safety Precautions section of this manual.

Note : If unforeseen circumstance create conflict between the following servicing precautions and any of the safety precautions, always follow the safety precautions. Remember: Safety First.

1-2-1 General Servicing Precautions

- (1) a. Always unplug the instrument's AC power cord from the AC power source before (1) removing or reinstalling any component, circuit board, module or any other instrument assembly, (2) disconnecting any instrument electrical plug or other electrical connection, (3) connecting a test substitute in parallel with an electrolytic capacitor in the instrument.
- b. Do not defeat any plug/socket B+ voltage interlocks with which instruments covered by this service manual might be equipped.
- c. Do not apply AC power to this instrument and /or any of its electrical assemblies unless all solid-state device heat sinks are correctly installed.
- d. Always connect a test instrument's ground lead to the instrument chassis ground before connecting the test instrument positive lead. Always remove the test instrument ground lead last.

Note : Refer to the Safety Precautions section ground lead last.

- (2) The service precautions are indicated or printed on the cabinet, chassis or components. When servicing, follow the printed or indicated service precautions and service materials.
- (3) The components used in the unit have a specified flame resistance and dielectric strength. When replacing components, use components which have the same ratings. Components identified by shading, by (⚡) or by (⚡) in the circuit diagram are important for safety or for the characteristics of the unit. Always replace them with the exact replacement components.

- (4) An insulation tube or tape is sometimes used and some components are raised above the printed wiring board for safety. The internal wiring is sometimes clamped to prevent contact with heating components. Install such elements as they were.

- (5) After servicing, always check that the removed screws, components, and wiring have been installed correctly and that the portion around the serviced part has not been damaged and so on. Further, check the insulation between the blades of the attachment plug and accessible conductive parts.

1-2-2 Insulation Checking Procedure

Disconnect the attachment plug from the AC outlet and turn the power ON. Connect the insulation resistance meter (500V) to the blades of the attachment plug. The insulation resistance between each blade of the attachment plug and accessible conductive parts(see note) should be more than 1 Megohm.

Note : Accessible conductive parts include metal panels, input terminals, earphone jacks, etc.

1-3 ESD Precautions

Electrostatically Sensitive Devices (ESD)

Some semiconductor (solid state) devices can be damaged easily by static electricity.

Such components commonly are called Electrostatically Sensitive Devices(ESD). Examples of typical ESD devices are integrated circuits and some field-effect transistors and semiconductor chip components. The following techniques should be used to help reduce the incidence of component damage caused by static electricity.

- (1) Immediately before handling any semiconductor component or semiconductor-equipped assembly, drain off any electrostatic charge on your body by touching a known earth ground. Alternatively, obtain and wear a commercially available discharging wrist strap device, which should be removed for potential shock reasons prior to applying power to the unit under test.
- (2) After removing an electrical assembly equipped with ESD devices, place the assembly on a conductive surface such as aluminum foil, to prevent electrostatic charge buildup or exposure of the assembly.
- (3) Use only a grounded-tip soldering iron to solder or unsolder ESD devices.
- (4) Use only an anti-static solder removal devices. Some solder removal devices not classified as "anti-static" can generate electrical charges sufficient to damage ESD devices.
- (5) Do not use freon-propelled chemicals. These can generate electrical charges sufficient to damage ESD devices.
- (6) Do not remove a replacement ESD device from its protective package until immediately before your are ready to install it.(Most replacement ESD devices are packaged with leads electrically shorted together by conductive foam, aluminum foil or comparable conductive materials).

- (7) Immediately before removing the protective materials from the leads of a replacement ESD device, touch the protective material to the chassis or circuit assembly into which the device will be installed.

CAUTION : Be sure no power is applied to the chassis or circuit, and observe all other safety precautions.

- (8) Minimize bodily motions when handling unpackaged replacement ESD devices. (Otherwise harmless motion such as the brushing together of your clothes fabric or the lifting of your foot from a carpeted floor can generate static electricity sufficient to damage an ESD device).

1-4 Handling the optical pick-up

The laser diode in the optical pick up may suffer electrostatic breakdown because of potential static electricity from clothing and your body.

The following method is recommended.

- (1) Place a conductive sheet on the work bench (The black sheet used for wrapping repair parts.)
- (2) Place the set on the conductive sheet so that the chassis is grounded to the sheet.
- (3) Place your hands on the conductive sheet (This gives them the same ground as the sheet.)
- (4) Remove the optical pick up block
- (5) Perform work on top of the conductive sheet. Be careful not to let your clothes or any other static sources to touch the unit.
 - ◆ Be sure to put on a wrist strap grounded to the sheet.
 - ◆ Be sure to lay a conductive sheet made of copper etc. Which is grounded to the table.

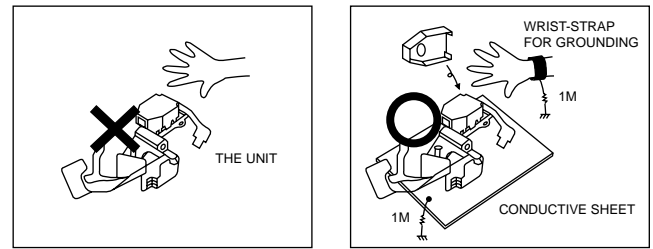

Fig.1-3

- (6) Short the short terminal on the PCB, which is inside the Pick-Up ASS'Y, before replacing the Pick-Up. (The short terminal is shorted when the Pick-Up Ass'y is being lifted or moved.)
- (7) After replacing the Pick-up, open the short terminal on the PCB.

1-5 Pick-up disassembly and reassembly

1-5-1 Disassembly

- 1) Remove the power cord.
- 2) Disassemble the Deck-Assy.
- 3) Make solder land 2 points short on Pick-up.
(See Fig. 1-4)
- 4) Disassembly the Pick-up.

1-5-2 Assembly

- 1) Replace the Pick-up.
- 2) Remove the soldering 2 points on Pick-up.
- 3) Reassemble the Deck-Assy.

Note : If the assembly and disassembly are not done in correct sequence, the Pick-up may be damaged.

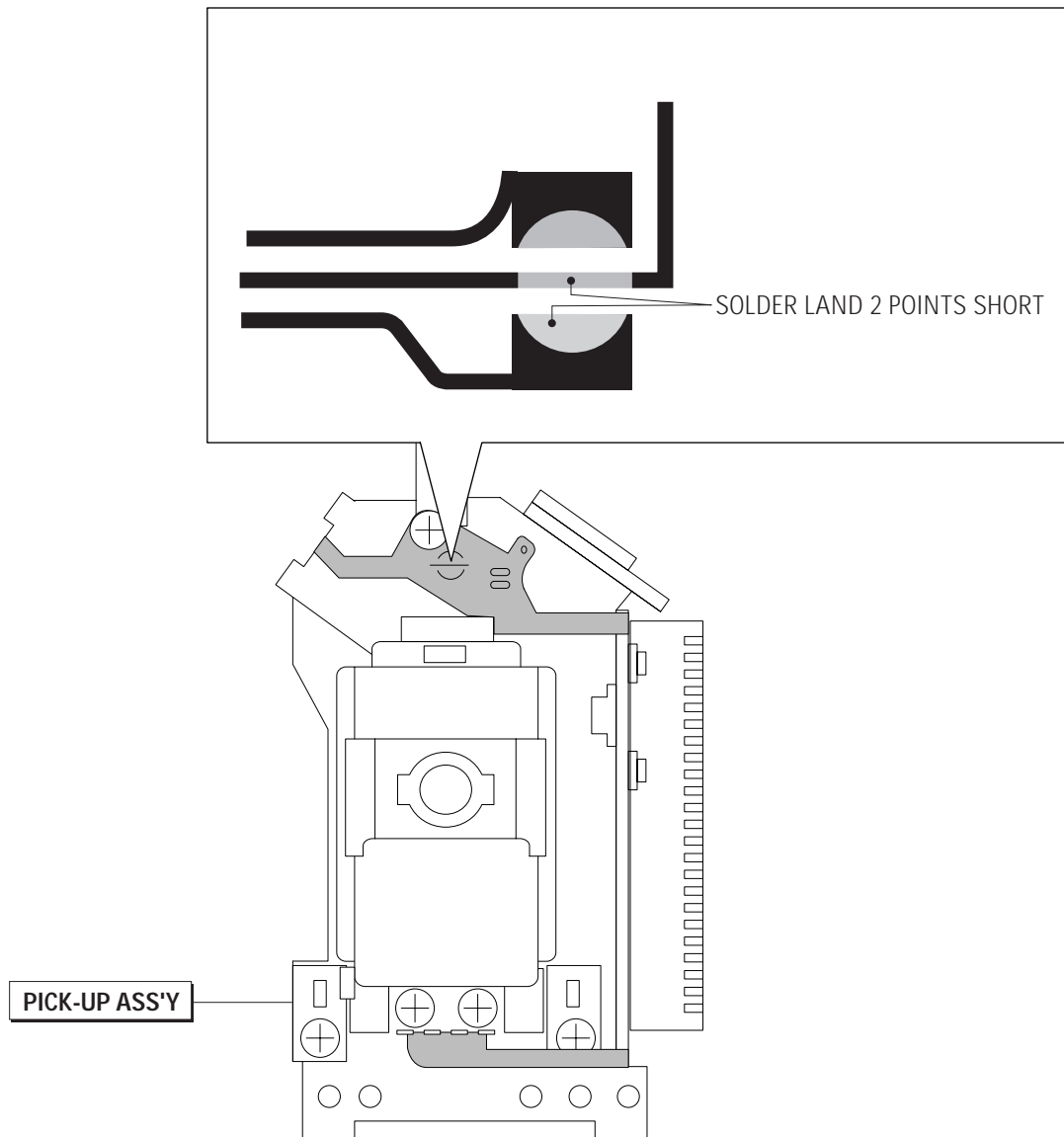

Fig. 1-4