



VIDEO CASSETTE RECORDER

SVR-433
SVR-233
SVR-230B
SVR-230W
SVR-2301
SVR-131

SERVICE Manual

For mechanical disassembly and adjustment, refer to the "Mechanical Manual" (DX-9R → AC68-00001A).

VIDEO CASSETTE RECORDER

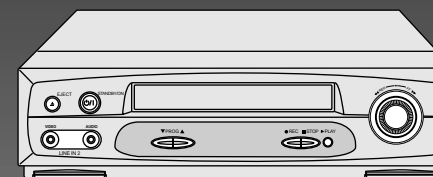

SVR-433/233

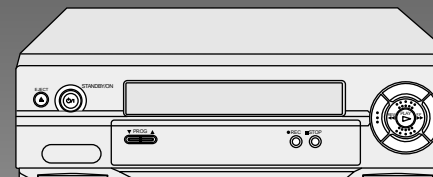

SVR-230B/230W

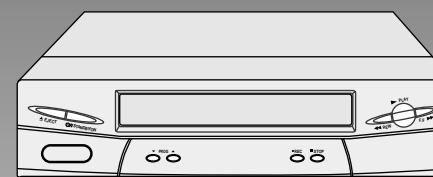

SVR-2301

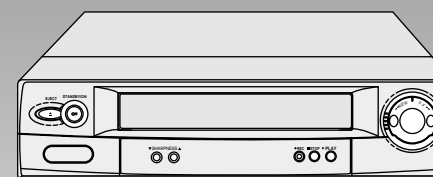

SVR-131

CONTENTS

1. Precautions
2. Alignment and Adjustment
3. Exploded View and Parts List
4. Electrical Parts List
5. Schematic Diagrams



SERVICE MANUAL

SVR-433/233/230B/230W/2301/131

1. Precautions

1. Be sure that all of the built-in protective devices are replaced. Restore any missing protective shields.
2. When reinstalling the chassis and its assemblies, be sure to restore all protective devices, including : control knobs and compartment covers.
3. Make sure that there are no cabinet openings through which people--particularly children --might insert fingers and contact dangerous voltages. Such openings include the spacing between the picture tube and the cabinet mask, excessively wide cabinet ventilation slots, and improperly fitted back covers.

If the measured resistance is less than 1.0 megohm or greater than 5.2 megohms, an abnormality exists that must be corrected before the unit is returned to the customer.

4. Leakage Current Hot Check (See Fig. 1-1) :
Warning : Do not use an isolation transformer during this test. Use a leakage current tester or a metering system that complies with American National Standards Institute (ANSI C101.1, Leakage Current for Appliances), and Underwriters Laboratories (UL Publication UL1410, 59.7).
5. With the unit completely reassembled, plug the AC line cord directly the power outlet. With the unit's AC switch first in the ON position and then OFF, measure the current between a known earth ground (metal water pipe, conduit, etc.) and all exposed metal parts, including : antennas, handle brackets, metal cabinets, screwheads and control shafts. The current measured should not exceed 0.5 milliamp. Reverse the power-plug prongs in the AC outlet and repeat the test.
6. X-ray Limits :
The picture tube is designed to prohibit X-ray emissions. To ensure continued X-ray protection, replace the picture tube only with one that is the same type as the original.

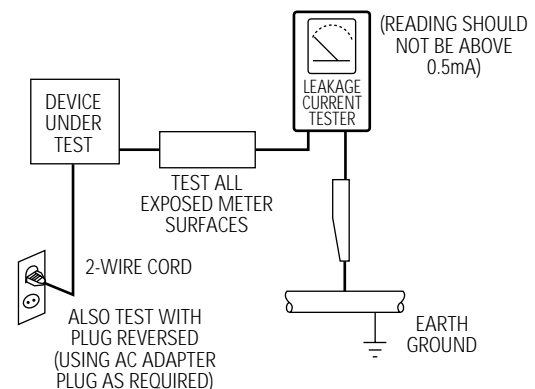

Fig. 1-1 AC Leakage Test

7. Antenna Cold Check :
With the unit's AC plug disconnected from the AC source, connect an electrical jumper across the two AC prongs. Connect one lead of the ohmmeter to an AC prong. Connect the other lead to the coaxial connector.
8. High Voltage Limit :
High voltage must be measured each time servicing is done on the B+, horizontal deflection or high voltage circuits.

Heed the high voltage limits. These include the X-ray protection Specifications Label, and the Product Safety and X-ray Warning Note on the service data schematic.
9. Some semiconductor ("solid state") devices are easily damaged by static electricity. Such components are called Electrostatically Sensitive Devices (ESDs); examples include integrated circuits and some field-effect transistors. The following techniques will reduce the occurrence of component damage caused by static electricity.
10. Immediately before handling any semiconductor components or assemblies, drain the electrostatic charge from your body by touching a known earth ground. Alternatively, wear a discharging Wrist-strap device. (Be sure to remove it prior to applying power--this is an electric shock precaution.)

11. High voltage is maintained within specified limits by close-tolerance, safety-related components and adjustments. If the high voltage exceeds the specified limits, check each of the special components.
12. Design Alteration Warning :
Never alter or add to the mechanical or electrical design of this unit. Example : Do not add auxiliary audio or video connectors. Such alterations might create a safety hazard. Also, any design changes or additions will void the manufacturer's warranty.
13. Hot Chassis Warning :
Some TV receiver chassis are electrically connected directly to one conductor of the AC power cord. If an isolation transformer is not used, these units may be safely serviced only if the AC power plug is inserted so that the chassis is connected to the ground side of the AC source.

To confirm that the AC power plug is inserted correctly, do the following : Using an AC voltmeter, measure the voltage between the chassis and a known earth ground. If the reading is greater than 1.0V, remove the AC power plug, reverse its polarity and reinsert. Re-measure the voltage between the chassis and ground.
14. Some TV chassis are designed to operate with 85 volts AC between chassis and ground, regardless of the AC plug polarity. These units can be safely serviced only if an isolation transformer inserted between the receiver and the power source.
15. Never defeat any of the B+ voltage interlocks. Do not apply AC power to the unit (or any of its assemblies) unless all solid-state heat sinks are correctly installed.
16. Always connect a test instrument's ground lead to the instrument chassis ground before connecting the positive lead; always remove the instrument's ground lead last.
17. Observe the original lead dress, especially near the following areas : Antenna wiring, sharp edges, and especially the AC and high voltage power supplies. Always inspect for pinched, out-of-place, or frayed wiring. Do not change the spacing between components and the printed circuit board. Check the AC power cord for damage. Make sure that leads and components do not touch thermally hot parts.
18. Picture Tube Implosion Warning :
The picture tube in this receiver employs "integral implosion" protection. To ensure continued implosion protection, make sure that the replacement picture tube is the same as the original.
19. Do not remove, install or handle the picture tube without first putting on shatterproof goggles equipped with side shields. Never handle the picture tube by its neck. Some "in-line" picture tubes are equipped with a permanently attached deflection yoke; do not try to remove such "permanently attached" yokes from the picture tube.
20. Product Safety Notice :
Some electrical and mechanical parts have special safety-related characteristics which might not be obvious from visual inspection. These safety features and the protection they give might be lost if the replacement component differs from the original—even if the replacement is rated for higher voltage, wattage, etc.

Components that are critical for safety are indicated in the circuit diagram by shading, (⚠ or ⚡).
Use replacement components that have the same ratings, especially for flame resistance and dielectric strength specifications. A replacement part that does not have the same safety characteristics as the original might create shock, fire or other hazards.

IMPORTANT SERVICE GUIDE

MODE SWITCH (PROGRAM SWITCH) ASSEMBLY POINT

1) When installing the ass'y full deck on the Main PCB, be sure to align the assembly point of mode switch.

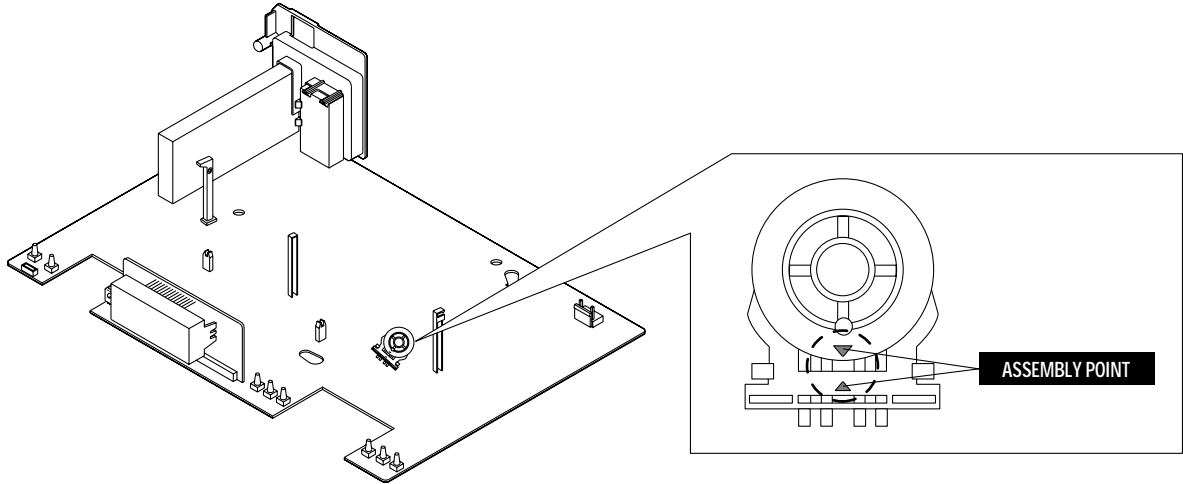

Fig. 1

HOW TO EJECT THE CASSETTE TAPE

(If the unit does not operate on condition that tape is inserted into housing ass'y)

- 1) Remove the Holder Worm ❶ and the gear worm ❷. (See Fig. 2)
- 2) Turn the Gear Worm Wheel ❸ counterclockwise in the direction of arrow with screw driver. (See Fig. 2)
- 3) When Slider S, T are approached in the position of unloading, rotate holder Clutch counterclockwise after inserting screw driver in the hole of frame's bottom in order to wind the unwounded tape. (Refer to Fig. 3)
(If you rotate Gear Worm Wheel continuously when tape is in state of unwinding, you may cause a tape contamination by grease and tape damage. Be sure to wind the unwounded tape in the state of set horizontally.)
- 4) Rotate Gear Worm Wheel ❸ counterclockwise using screw driver again up to the state of eject mode and then pick out the tape. (Refer to Fig. 2)

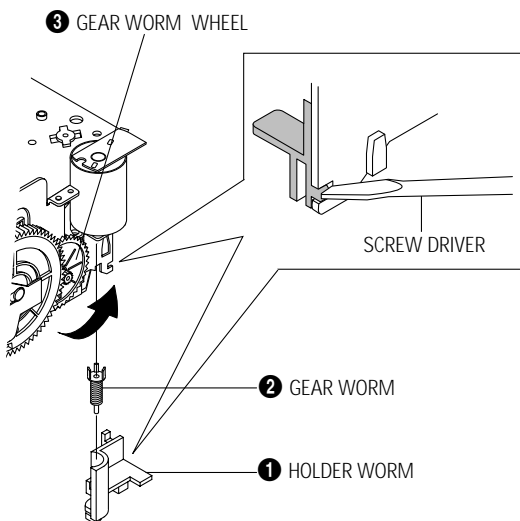

Fig. 2

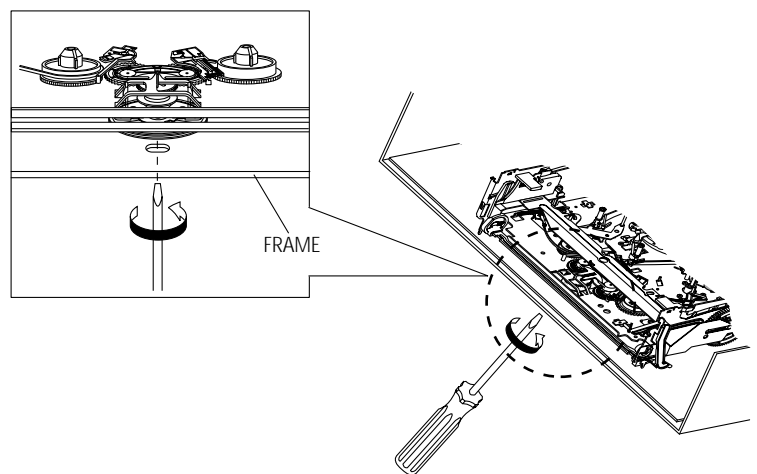

Fig. 3

2. Alignment and Adjustment

2-1 Reference

- 1) X-Point (Tracking center) adjustment, "Head switching adjustment" and "NVRAM option setting" can be adjusted with remote control.
- 2) When replacing the Micom (IC601) and NVRAM (IC605 ; EEPROM) be sure to adjust the "Head switching adjustment" and "NVRAM option setting".
- 3) When replacing the cylinder ass'y, be sure to adjust the "X-Point" and "Head switching adjustment".
- 4) Among Samsung VCR remote control used for adjustment as a accessory, only the remote control that has figures buttons (0 ~ 9) is available for all adjustment regardless of chassis.
- 5) How to adjustment.
 - Press the "SW718 (TEST)" button on Main PCB to set the adjustment mode.
 - If the corresponding adjustment button is pressed, the adjustment is performed automatically.
 - If the adjustment is completed, be sure to turn the power off.

2-1-1 Location of adjustment button of remote control

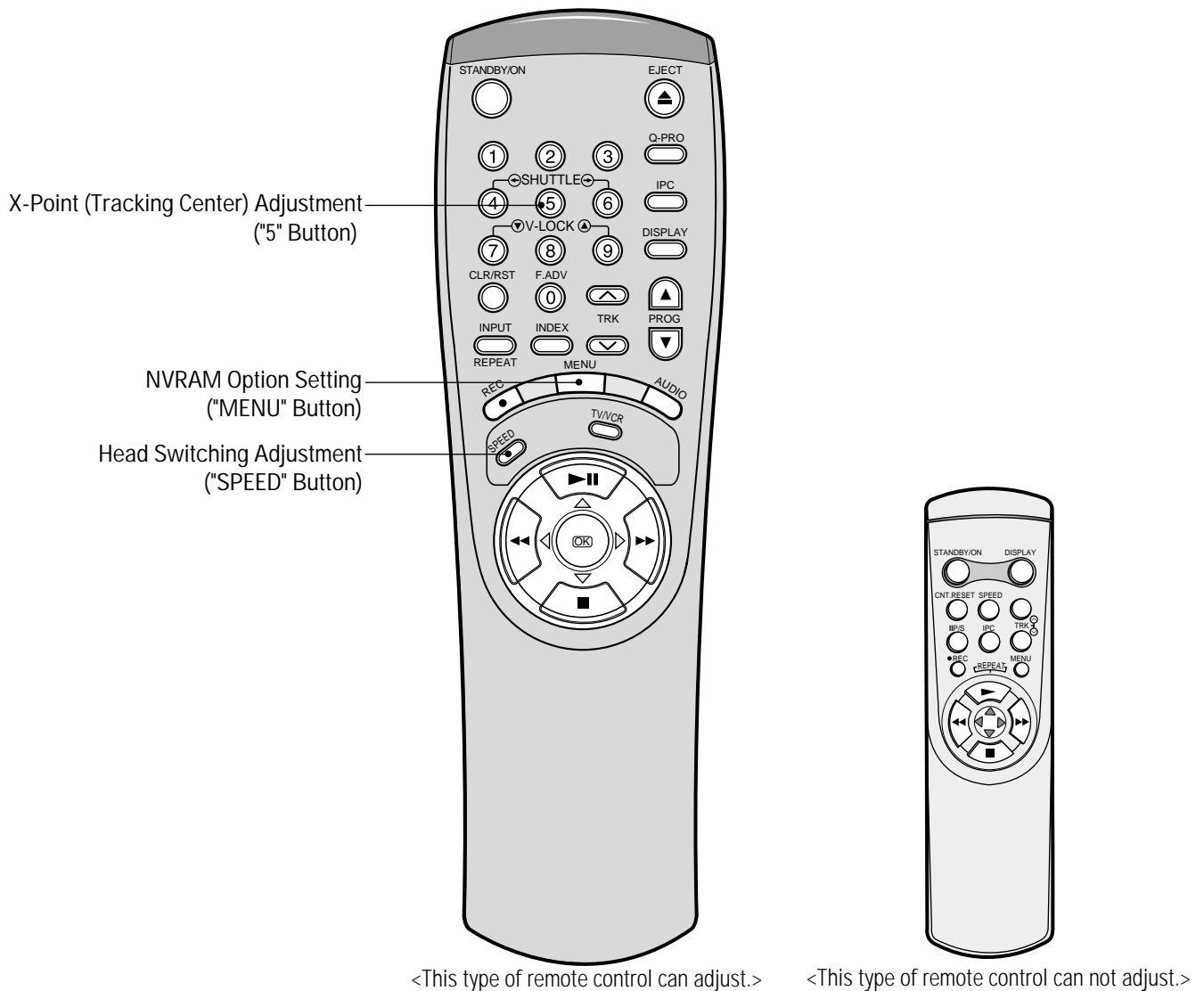

Remote Control for adjustment is not supplied as a Service Jig.

Fig. 2-1

2-1-2 SW718 (TEST) location for adjustment mode setting

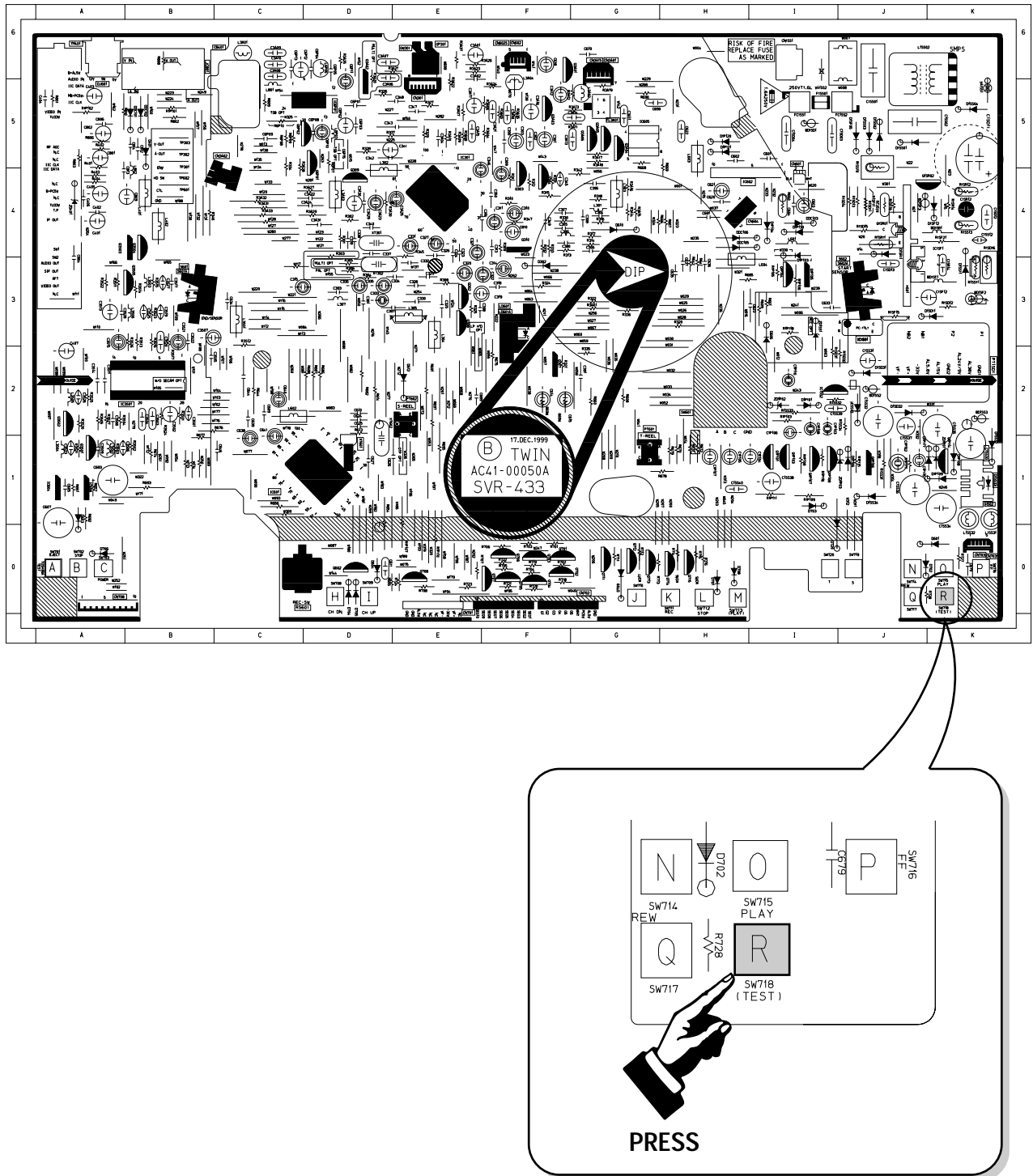

Fig. 2-2 Main PCB (Top View)

2-2 Mechanical Adjustment

Note : Refer to the Mechanical Manual “DX-9R (AC68-00001A)” for the adjustment and confirmation of ass’y full deck.

2-2-1 The number and position of test point

Test point :

- TP601 (Control Pulse)
- TP602 (H'D S/W -Trigger)
- TP301 (Envelope)
- TP302 (Audio output)
- TP303 (Video output)

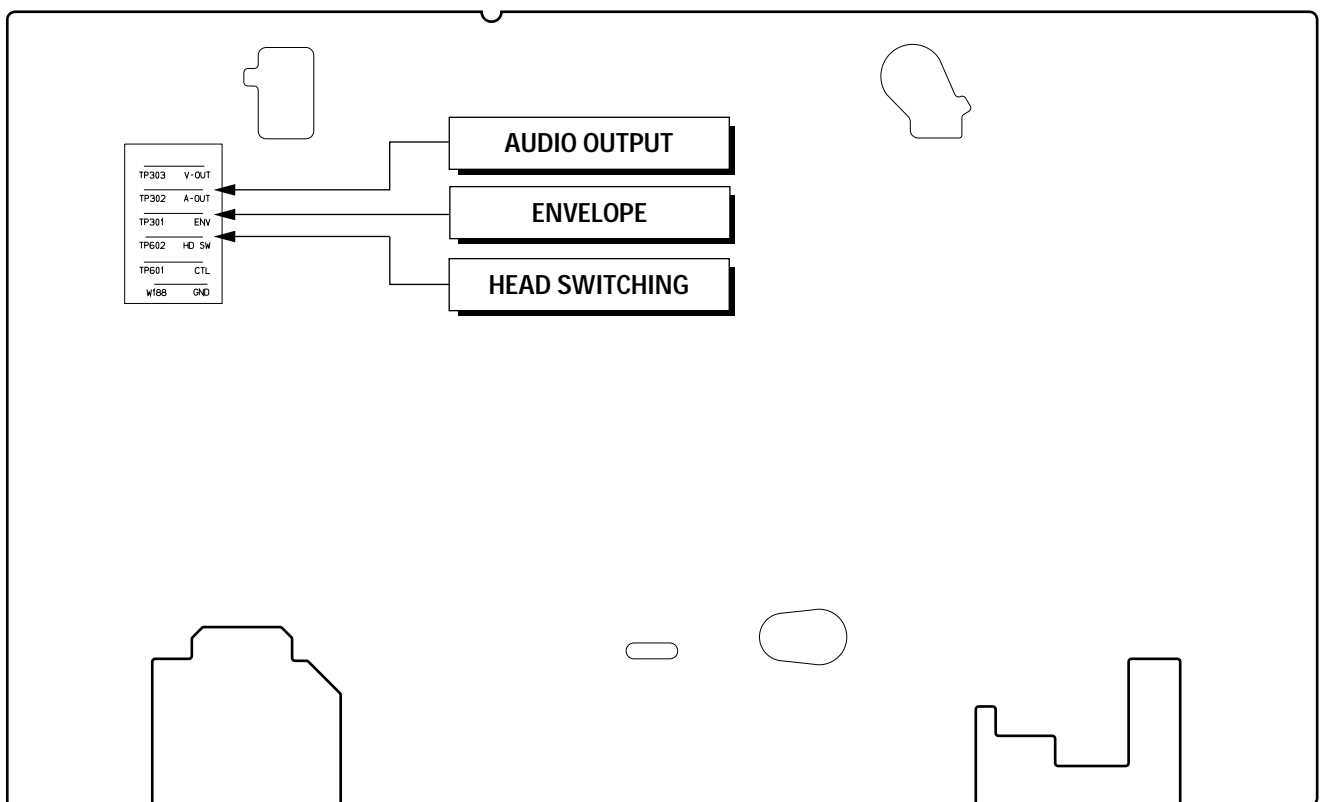

Fig. 2-3 Location of Test point (Main PCB-Top View)

2-2-2 ACE Head Position (X-Point) Adjustment (See the 2-2-1(d) ACE Head Position (X-Point) Adjustment on page 2-2 of the Mechanical Manual)

- 1) Playback the alignment tape (Color bar).
- 2) Press the “SW718 (TEST)” button on Main PCB to set the adjustment mode. (See Fig. 2-2)
- 3) Press the “5” button of remote control then adjustment is operated automatically. (See Fig. 2-1)
- 4) Connect the CH-1 probe to TP301 (Envelope) the CH-2 probe to TP602 (H'D switching pulse) and then trigger to CH-1.
- 5) Insert the (-) driver into the X-Point adjustment hole and adjust it so that envelope waveform is maximum.
- 6) Turn the Power off.

2-3 Head Switching Point Adjustment

- 1) Playback the alignment tape.
- 2) Press the "SW718 (TEST)" button on Main PCB to set the adjustment mode. (See Fig. 2-2)
- 3) Press the "SPEED" button of remote control then adjustment is operated automatically. (See Fig. 2-1)
- 4) Turn the Power off.

2-4 NVRAM Option Setting

- 1) NVRAM Option is adjusted at production line basically.
- 2) In case Micom (IC601) and NVRAM (IC605 ; EEPROM) is replaced, be sure to set the corresponding option number of the repaired model. (If the option is not set, the unit is not operated.)

- 1) Press the "SW718 (TEST)" button on Main PCB to set the adjustment mode. (See Fig. 2-2)
- 2) Press the "MENU" button on the remote control about 5 seconds then option setting display is appeared. (See Fig. 2-4 and 2-5)
- 3) Select the option number (See Table 2-1 ; Page 2-5) of corresponding model with "FF" and "REW" button on the remote control.
- 4) If selecting the option number is completed, press the "PLAY" button of remote control. (If "PLAY" button is pressed, the selected number is changes reversed color ; See Fig. 2-4 and 2-5)
- 5) Press the "OK (VCR)", "MENU (VCP)" button of remote control again to store the option number. ("PLEASE WAIT" is displayed for a second as shown Fig. 2-6, 2-7 and this setting is completed.)
- 6) Turn the Power off.

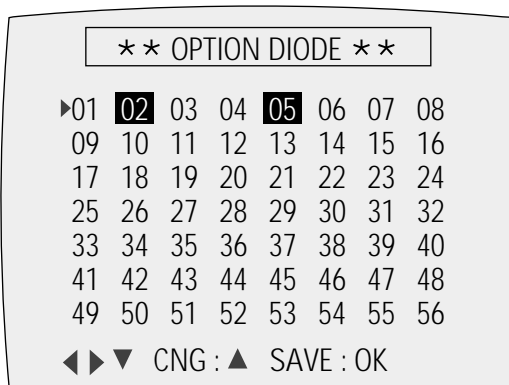

Fig. 2-4 (VCR)

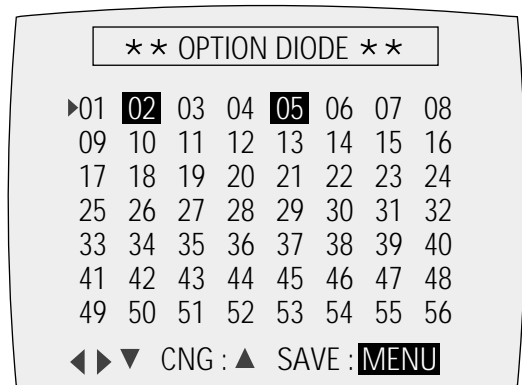

Fig. 2-5 (VCP)

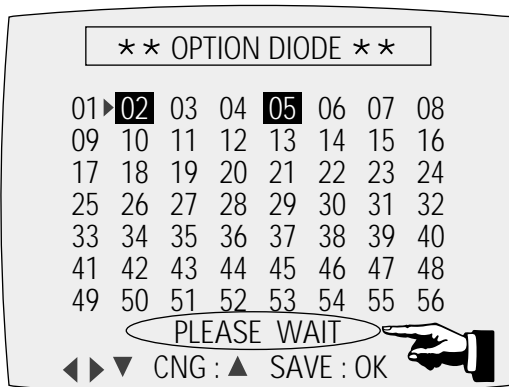

Fig. 2-6 (VCR)

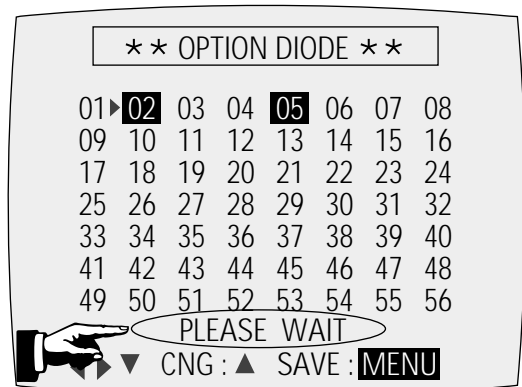

Fig. 2-7 (VCP)

<Table 2-1>

COUNTRY	MODELS	OPTION NUMBER
RUSSIA	SVR-433	6, 8, 11, 12, 17, 18, 22, 25, 30, 31, 32, 35, 41, 42, 45, 50, 54
	SVR-233	6, 8, 11, 17, 18, 22, 25, 30, 31, 32, 34, 41, 42, 45, 50, 54
	SVR-230B	8, 11, 17, 18, 22, 25, 30, 31, 32, 34, 37, 38, 41, 42, 50, 54
	SVR-230W	8, 11, 17, 18, 22, 25, 30, 31, 32, 34, 37, 38, 41, 42, 50, 54
	SVR-2301	8, 11, 17, 18, 22, 25, 30, 31, 32, 34, 37, 38, 42, 50, 54
	SVR-131	8, 9, 10, 11, 17, 18, 22, 30, 31, 32, 34, 39, 42, 45

MEMO

3. Exploded View and Parts List

	Page
3-1 Cabinet Assembly - - - - -	3-2
3-2 Mechanical Parts (Top Side) - - - - -	3-4
3-3 Mechanical Parts (Bottom Side) - - - - -	3-6

3-1 Cabinet Assembly

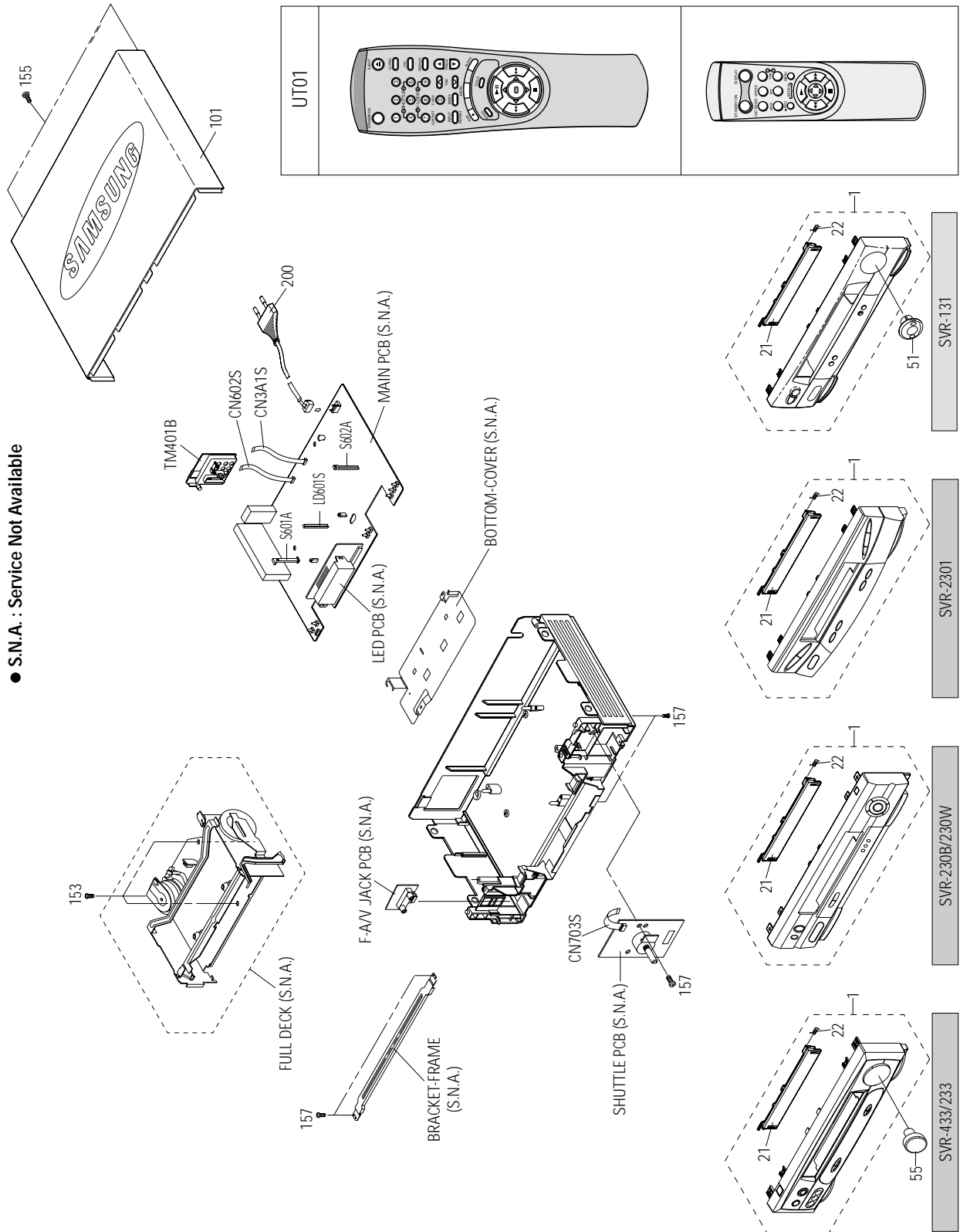

Loc. No	Parts No.	Description ; Specification	Remark
1	Refer to table below	ASSY-PANEL FRONT;ABS94HB,-	
21	Refer to table below	DOOR-CASSETTE;-ABS,-,T2.5,189*28,GRAY,-	
22	AC61-62032A	SPRING-MASK;X-9,-,SUS,-,4.4,-,SV-C130	
51	Refer to table below	KNOB-SHUTTLE;-ABS,-,GRAY,HB,SV-130G,-	
101	Refer to table below	CABINET-TOP;X-9,SECC,PCM,0.5,360*208*41,	
153	AC60-12126A	SCREW-BH;-BH,-,4*12,FE,FZY,-,-,-	
155	AC60-12134A	SCREW-TAP BH;-BH,-,2-4X16,-,FE	
157	AC60-10063A	SCREW-TAPTITE;BH,+,-,M3,L12,ZPC3,SWRCH18	
200	AC39-10019A	POWER CORD;KKP-419C,H03VVH2-F,VDE/KEMA-K	
CN3A1S	3809-001110	CABLE-FLAT;30V,80C,150mm,7P,1.25mm,UL289	
CN602S	3809-001112	CABLE-FLAT;30V,80C,130mm,5P,1.25mm,UL289	
CN703S	3809-001112	CABLE-FLAT;30V,80C,130mm,5P,1.25mm,UL289	SHUTTLE MODELS ONLY
LD601A	AC61-21009A	HOLDER-LED;-POM(M90-44)-,BLK,-,X-9	
S601A	AC61-21008A	HOLDER-SENSOR;-POM(M90-44)-,BLK,-,X-9	
S602A	AC61-21008A	HOLDER-SENSOR;-POM(M90-44)-,BLK,-,X-9	
TM401B	Refer to table below	CON-BOARD ASSY;-HIPS,-,T2,61,-,BLK,-,-,	
UT01	Refer to table below	REMOCON-ASSY;-NR4834,-,34KEY,TWIN_M_PAL	

MODELS	1	21	51	101	TM401B	UT01
SVR-433	AC97-00872A	AC64-00203N	AC64-00319A	AC64-30892A	AC61-11063C	AC59-00016F
SVR-233	AC97-00873A	AC64-00203P	AC64-00319A	AC64-30892A	AC61-11063C	AC59-00016F
SVR-230B	AC97-00621H	AC64-00177X	-	AC64-30892A	AC61-11063C	AC59-00016F
SVR-230W	AC97-00621Y	AC64-00177D	-	AC64-00293D	AC61-11063C	AC59-00016H
SVR-2301	AC97-00850A	AC64-00097P	-	AC64-30892A	AC61-11063C	AC59-00017B
SVR-131	AC97-00621J	AC64-00069D	AC64-00216G	AC64-30892A	AC61-11063C	AC59-00013C

3-2 Mechanical Parts (Top Side)

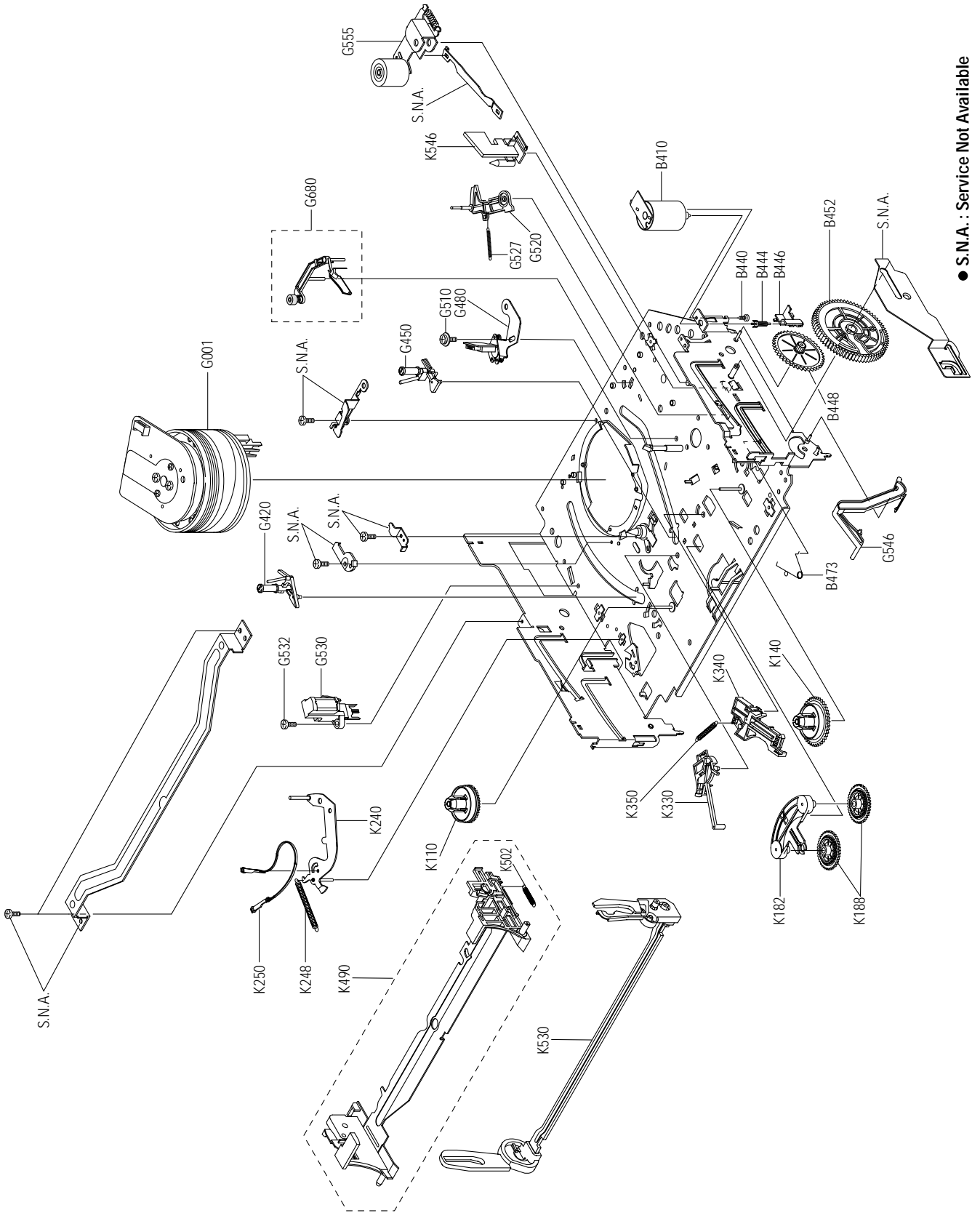

Loc. No	Parts No.	Description ; Specification	Remark
B410	AC31-12016D	MOTOR-LOADING ASSY;-;SNHNE,-,-	
B440	AC60-10515A	SCREW-MACHINE;-;PH,+,-,M3,L3,ZPC,-,YEL	
B444	AC66-20571A	GEAR-WORM;-;POM SW-01,0.5,2,-,4.5,X-9	
B446	AC61-21005A	HOLDER-WORM;-;POM M90-44,-,-,-,X-9	
B448	AC66-20573A	GEAR-WORM WHEEL;-;POM SW-01,0.6,11,-,6.6	
B452	AC66-20575A	GEAR-FL CAM;-;POM SW-01,M0.6,Z88,-,PCD58	
B473	AC61-60559A	SPRING-PINCH DRIVE;-;TS,SUS304,PI0.5,OD4	
G001	AC97-00558A	ASSY-CYLINDER;CX-9T,PAL 4HD/DLC	(SVR-433)
	AC97-00554A	ASSY-CYLINDER;CX-9T, PAL 2HD(LP)/DLC	(SVR-233/230B/230W/230I)
	AC97-00555A	ASSY-CYLINDER;CX-9T, PAL 2HD(LP)	(SVR-131)
G420	AC66-80142A	SLIDER-SUPPLY ASSY;-;X-9(TS),-,-,-,X-9	
G450	AC66-80141A	SLIDER-TAKE UP ASSY;-;X-9(TS),-,-,-,X-9	
G480	AC33-00003A	HEAD-ACE ASSY;SHINHEUNG;-,-,-,-,X-9	
G510	6006-001075	SCREW-ASSY TAPT;WSP,PH,+,-,M2.6,L5.0,ZPC	
G520	AC66-30539A	LEVER-#9 GUIDE ASSY;-;X-9(TS),-,-,-,X-9	
G527	AC61-60553A	SPRING-#9 GUIDE;-;ES,SUS304-WPB,OD3.1,0.	
G530	AC33-00002A	HEAD-FE;-;HVFHP0038A,-,-,-,X-9	
G532	AC60-10519A	SCREW-TAP TITE;-;PH,+,-,M2.6,L8,ZPC	
G546	AC66-30535A	LEVER-FL DOOR;-;POM M90-44,-,-,BLK,X-9	
G555	AC59-90403A	UNIT-PINCH ASSY;X-9,-	
G680	AC66-30557A	LEVER-H/CLEANER ASSY;-;POM+URETHANE,-,-	(OPTIONAL)
K110	AC66-10267A	REEL-DISK S;-;POM M90-44,-,-,X-9	
K140	AC66-10268A	REEL-DISK T;-;POM M90-44,-,-,X-9	
K182	AC66-30524A	LEVER-IDLER;-;POM9044,-,-,-,-	
K188	AC66-20577A	GEAR-IDLER;-;PEBAX 7033,-,-,-,-,X-9	
K240	AC66-30538A	LEVER-TENSION ASSY;-;X-9(TS),-,-,-,X-9	
K248	AC61-60554A	SPRING-TENSION LEVER;-;ES,SUS304-WPB,OD3	
K250	AC63-12029A	BAND-BRAKE ASSY;-;X-9(TS),-,-,-,X-9	
K330	AC66-30550A	LEVER-S.BRAKE ASSY;-;POM+SUS,-,-,-,X-9	
K340	AC66-30549A	LEVER-T.BRAKE ASSY;-;POM+SUS,-,-,-,X-9	
K350	AC61-60564A	SPRING-BRAKE;-;TENSION,SWP-A,0.25,3,-,X-	
K490	AC61-21010B	HOLDER-CASS ASSY;-;SECC+POM+SUS,-,-,-,X-	
K502	AC61-60561A	SPRING-FL.LEVER-LR;-;ES,SUS304 WPB,PI2.7	
K530	AC66-30546A	LEVER-FL.ARM ASS'Y;-;SECC+POM+SUS,-,-,-,-	
K546	AC61-50658A	GUIDE-CASS. DOOR;-;POM M90-44,-,-,NTR,-,	

3-3 Mechanical Parts (Bottom Side)

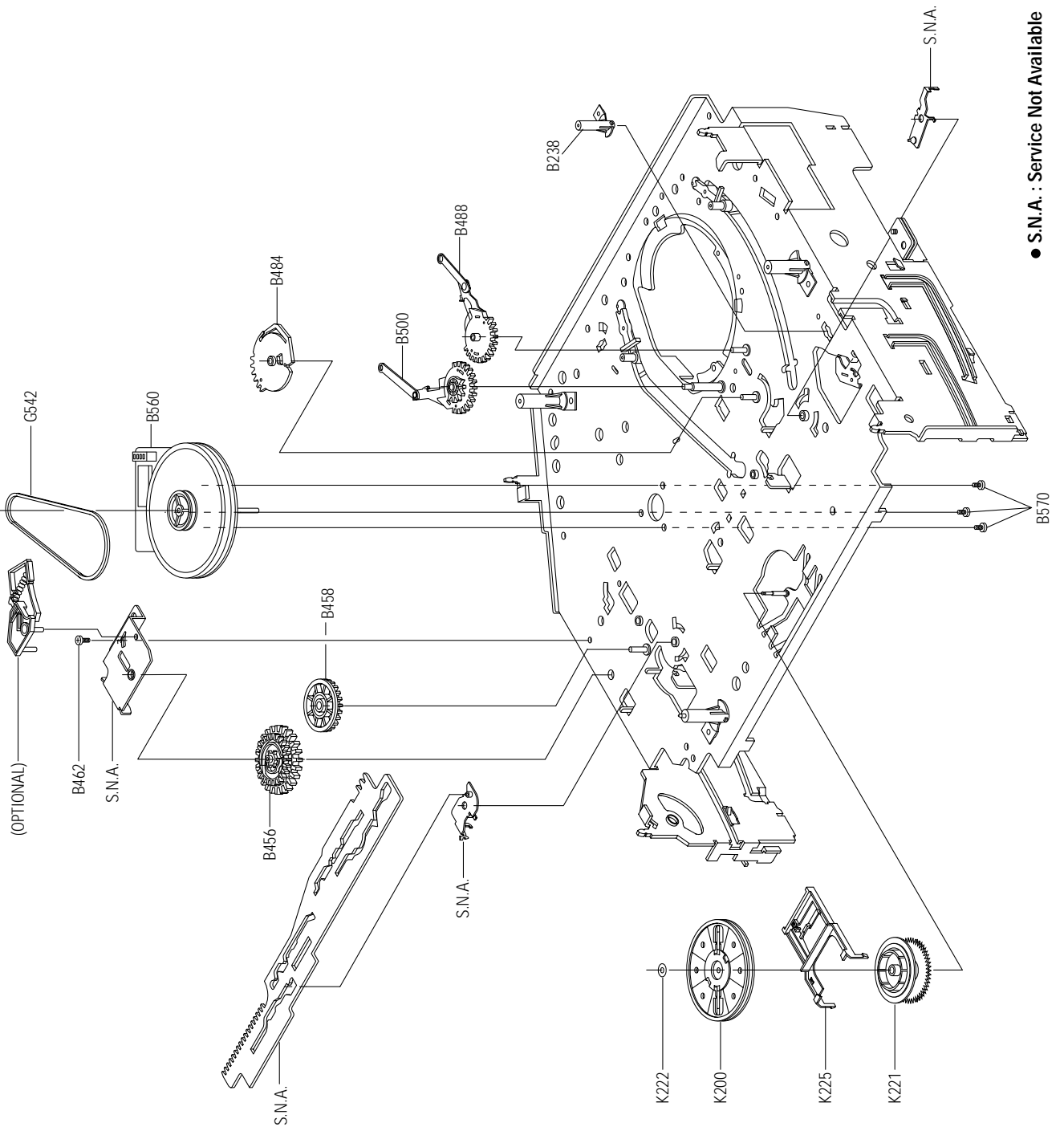

● S.N.A. : Service Not Available

Loc. No	Parts No.	Description ; Specification	Remark
B238	AC61-50660A	SLEEVE-TENSION;-;POM M90-44,-,-,ID3,-,-,	
B456	AC66-20576A	GEAR-JOINT 1;-;POM SW-01,M1.0,Z22,-,PCD2	
B458	AC66-20574A	GEAR-JOINT 2;-;POM SW-01,M1.0,Z14,-,PCD1	
B462	AC60-10517A	SCREW-TAP TITE;-;PH,+,-,M2.6,L5,ZPC,-,YE	
B484	AC66-20580A	GEAR-LOADING DRIVE;-;POM SW-01,M1.0,Z32,	
B488	AC66-30543A	LEVER-S LOAD ASSY;-,-,-,-,-,X-9	
B500	AC66-30542A	LEVER-T LOAD ASSY;-,-,-,-,-,X-9	
B560	AC31-00005A	MOTOR-CAPSTAN;-;F2QSB02,-,-	
B570	AC60-10514A	SCREW-CAPSTAN;-;PH,+,-,M2.6,L6,-	
G542	AC66-60051A	BELT-PULLEY;-;5CM-70,2 * 2,-,-,71.3,-,X-9	
K200	AC61-21012A	HOLDER-CLUTCH ASSY;-,-,-,-,-,X-9	
K221	AC66-20581A	GEAR-CENTER ASSY;-;POM,M=0.5,-,HIGHT T.,	
K222	AC60-30306A	WASHER-SLIT;-,-,ID2.1,OD5.0,T0.5,-,POLYS	
K225	AC66-30547A	LEVER-UP DOWN ASSY;-;POM+SUS,-,-,-,-,X-9	

MEMO

4. Electrical Parts List

Loc.No	Part No	Description ; Specification	Remark	Loc.No	Part No	Description ; Specification	Remark
-	-	ASSY PCB-MAIN	S.N.A.	R1SD16	2006-000273	R-CEMENT:27Kohm,5%,2W,CA,BK,6.4x27x6.4mm	SVR-2301 ONLY
S.M.P.S. PARTS				R1SD31	2001-000780	R-CARBON:470OHM,5%,1/8W,AA,TP,1.8X3.2MM	
BD1SD1	AC27-92001M	INDUCTOR:70UH-M RT BFS3565R2F,-,-,-,-		R1SD31	2001-000515	R-CARBON:220OHM,5%,1/8W,AA,TP,1.8X3.2MM	SVR-2301 ONLY
BD1SF1	3301-000297	CORE-FERRITE BEAD:AA,3.6x1.2x5.7mm,1400,	SVR-2301 NOT USER	R1SD32	2001-000429	R-CARBON:1KOHM,5%,1/8W,AA,TP,1.8X3.2MM	
BD1SF3	AC27-92001M	INDUCTOR:70UH-M RT BFS3565R2F,-,-,-,-	SVR-2301 NOT USER	R1SD31	2001-000221	R-CARBON:1.2KOHM,5%,1/8W,AA,TP,1.8X3.2MM	SVR-2301 ONLY
BD1SR1	3301-000297	CORE-FERRITE BEAD:AA,3.6x1.2x5.7mm,1400,	SVR-2301 ONLY	R1SF11	2001-000076	R-CARBON:47KOHM,5%,1/4W,AA,TP,2.4X6.4MM	SVR-2301 NOT USER
BD1SS3	AC27-92001M	INDUCTOR:70UH-M RT BFS3565R2F,-,-,-,-		R1SF15	2001-000591	R-CARBON:3.3KOHM,5%,1/8W,AA,TP,1.8X3.2MM	SVR-2301 NOT USER
C1SD03	2201-000828	C-CERAMIC,DISC:3.3nF,20%,400V,Y5U,TP,15x		R1SF19	2001-000429	R-CARBON:1KOHM,5%,1/8W,AA,TP,1.8X3.2MM	SVR-2301 NOT USER
C1SD04	2201-000828	C-CERAMIC,DISC:3.3nF,20%,400V,Y5U,TP,15x		R1SF20	2003-000105	R-METAL OXIDE:0.33ohm,5%,2W,AD,TP,6x16mm	SVR-2301 NOT USER
C1SD11	2401-003303	C-AL:82uF,20%,400V,GP,BK,22X30,10		R1SF21	2001-000096	R-CARBON(S):1MOHM,5%,1/2W,AA,TP,2.4X6.4MM	SVR-2301 NOT USER
C1SD11	2401-003302	C-AL:47uF,20%,400V,GP,TP,18X31.5,7.	SVR-2301 ONLY	R1SR11	2003-000119	R-METAL OXIDE:0.68ohm,5%,2W,AE,TP,6x16mm	SVR-2301 ONLY
C1SD12	2305-001029	C-FILM,MPEF:10nF,10%,630V,TP,12x9x12.5,5		R1SR12	2003-000264	R-METAL OXIDE:300ohm,5%,1W,AD,TP,4.3x12mm	SVR-2301 ONLY
C1SD12	2201-000828	C-CERAMIC,DISC:3.3nF,20%,400V,Y5U,TP,15x	SVR-2301 ONLY	R1SR14	2001-000003	R-CARBON:330ohm,5%,1/8W,AA,TP,1.8X3.2mm	SVR-2301 ONLY
C1SD13	2301-000361	C-FILM,PEF:1.2nF,10%,50V,TP,-,5mm	SVR-2301 ONLY	R1SS10	2006-000262	R-CEMENT:2.7ohm,10%,2W,CB,TP,7.5x11x20.	
C1SD13	2201-000376	C-CERAMIC,DISC:0.22nF,5%,50V,SL,TP,6.3x3		R1SS11	2003-000994	R-METAL OXIDE(S):33Kohm,5%,2W,AF,TP,3.9x	SVR-2301 NOT USER
C1SF12	2401-001200	C-AL:33uF,20%,50V,WT,TP,6.3x11,5	SVR-2301 NOT USER	R1SS13	2003-000148	R-METAL OXIDE:100OHM,5%,2W,AE,TP,6X16MM	
C1SR12	2401-000905	C-AL:22uF,20%,16V,BP,-,6x11,2.5mm	SVR-2301 ONLY	R1SS32	2001-000429	R-CARBON:1KOHM,5%,1/8W,AA,TP,1.8X3.2MM	
C1SR14	2301-000445	C-FILM,PEF:4.7nF,5%,50V,TP,5.5x7x3mm,5mm	SVR-2301 ONLY	R1SS33	2004-000869	R-METAL:3Kohm,1%,1/8W,AA,TP,1.8x3.2mm	
C1SS01	2305-001021	C-FILM,MPEF:100nF,20%,275V,TP,17.5x7x13.	△	R1SS34	2004-000459	R-METAL:2.2Kohm,1%,1/8W,AA,TP,1.8x3.2m	
C1SS02	2305-001021	C-FILM,MPEF:100nF,20%,275V,TP,17.5x7x13.	△	VA1SS1	1405-001026	VARISTOR:470V,600A,9x7mm,TP	△
C1SS12	2201-000129	C-CERAMIC,DISC:0.1nF,10%,1KV,Y5P,TP,7x4,		ZD1SS1	0403-000571	DIODE-ZENER:UZP43B.43V,40-46V,1W,DO-41,T	SVR-2301 ONLY
C1SS31	2401-000385	C-AL:10uF,20%,100V,GP,TP,6.3x11,5		POWER DRIVE PARTS			
C1SS33	2401-001126	C-AL:330uF,20%,25V,WT,TP,10x12.5,5		C1P102	2401-001507	C-AL:47uF,20%,16V,GP,TP,6.3x5,5	
C1SS34	2401-003477	C-AL:330uF,20%,25V,LZ,TP,10X12.5MM,		C1P103	2401-001915	C-AL:1uF,20%,50V,GP,TP,3x5,5	
C1SS35	2401-003480	C-AL:1000UF,20%,10V,LZ,TP,10X16MM,5		C1P104	2401-002299	C-AL:4.7uF,20%,50V,GP,TP,5x7,5	
C1SS36	2401-003480	C-AL:1000UF,20%,10V,LZ,TP,10X16MM,5		C1P105	2401-001507	C-AL:47uF,20%,16V,GP,TP,6.3x5,5	
C1SS39	2301-000129	C-FILM,PEF:100nF,5%,50V,TP,10X9X4.3X5,5m		C1P106	2401-001915	C-AL:1uF,20%,50V,GP,TP,3x5,5	
CN1SS1	3711-000178	CONNECTOR-HEADER:1WALL,2P,1R,3.96mm,STRA		C1P107	2401-001507	C-AL:47uF,20%,16V,GP,TP,6.3x5,5	
D1SD11	0402-001195	DIODE-RECTIFIER:FT14,400V,1.0A,TS-1,TP		C1P108	2401-001507	C-AL:47uF,20%,16V,GP,TP,6.3x5,5	
D1SD31	0402-001195	DIODE-RECTIFIER:FT14,400V,1.0A,TS-1,TP		C1P115	2401-001915	C-AL:1uF,20%,50V,GP,TP,3x5,5	SVR-2301 ONLY
D1SF05	0402-001196	DIODE-RECTIFIER:1T5,600V,1A,TS-1,TP	SVR-2301 NOT USER	D1P101	0401-000101	DIODE-SWITCHING:1N4148,100V,200mA,DO-35,	
D1SF12	0402-001195	DIODE-RECTIFIER:FT14,400V,1.0A,TS-1,TP	SVR-2301 NOT USER	D1P103	0402-000127	DIODE-RECTIFIER:1N4002,100V,1A,DO-41,TP	
D1SR11	0401-000101	DIODE-SWITCHING:1N4148,100V,200mA,DO-35,	SVR-2301 ONLY	D1P104	0402-000127	DIODE-RECTIFIER:1N4002,100V,1A,DO-41,TP	
D1SS01	0402-001196	DIODE-RECTIFIER:1T5,600V,1A,TS-1,TP		D1P106	0401-000101	DIODE-SWITCHING:1N4148,100V,200mA,DO-35,	
D1SS02	0402-001196	DIODE-RECTIFIER:1T5,600V,1A,TS-1,TP		D1P108	0402-000127	DIODE-RECTIFIER:1N4002,100V,1A,DO-41,TP	
D1SS03	0402-001196	DIODE-RECTIFIER:1T5,600V,1A,TS-1,TP		D1P109	0402-000127	DIODE-RECTIFIER:1N4002,100V,1A,DO-41,TP	SVR-131 NOT USER
D1SS04	0402-001196	DIODE-RECTIFIER:1T5,600V,1A,TS-1,TP		D1P117	0401-000101	DIODE-SWITCHING:1N4148,100V,200mA,DO-35,	
D1SS11	0402-000276	DIODE-RECTIFIER:UF4007,1KV,1A,DO-41,TP		D1P120	0402-000127	DIODE-RECTIFIER:1N4002,100V,1A,DO-41,TP	
D1SS32	0402-001194	DIODE-RECTIFIER:UG20,200V,2A,DO-204AC,TP		D1P121	0402-000127	DIODE-RECTIFIER:1N4002,100V,1A,DO-41,TP	
D1SS33	0402-000431	DIODE-RECTIFIER:FML-M02S,200V,2.5A,TO-22		Q1P101	0501-000616	TR-SMALL SIGNAL:KSC2328A-Y,NPN,1W,TO-92L	
F1SS01	3601-001208	FUSE-CARTRIDGE:250V,1.6A,TIME-LAG,GLASS	△	Q1P103	0501-000616	TR-SMALL SIGNAL:KSC2328A-Y,NPN,1W,TO-92L	
IC1SF1	1203-001802	IC-PWM CONTROLLER:STR-G6551,TO-220F,5P,-	SVR-2301 NOT USER	Q1P106	0504-000142	TR-DIGITAL:KSR2001,PNP,300MW,4.7Kx4.7K,T	
IC1SS1	0604-001028	PHOTO-COUPLER:TR,50-600%,250mW,DIP-4,ST	△	Q1P107	0501-000398	TR-SMALL SIGNAL:KSC945,NPN,250mW,TO-92,T	
IC1SS2	AC14-12006D	IC:KA431Z,TO-92,TAPING		Q1P108	0501-000398	TR-SMALL SIGNAL:KSC945,NPN,250mW,TO-92,T	
L1SS02	AC29-30050C	FILTER-LINE NOISE:-,25MH,0.35A,AC250V,BS	△	Q1P114	0501-000616	TR-SMALL SIGNAL:KSC2328A-Y,NPN,1W,TO-92L	
L1SS31	AC27-12001N	COIL-CHOKE:10UH-15%,RA,K-30,Q80,150KHZ,-		R1P101	2001-000855	R-CARBON:560OHM,5%,1/4W,AA,TP,2.4X6.4MM	
L1SS32	AC27-12001N	COIL-CHOKE:10UH-15%,RA,K-30,Q80,150KHZ,-		R1P102	2001-000855	R-CARBON:560OHM,5%,1/4W,AA,TP,2.4X6.4MM	
PT1SD1	AC26-00001D	TRANS-SWITCHING:-,100V-240V,DEMCO,EE2821	△	R1P103	2001-000034	R-CARBON:220OHM,5%,1/4W,AA,TP,2.4X6.4MM	
PT1SD1	AC26-00001E	TRANS-SWITCHING:-,230V,DEMCO,EE2821,1.3M	△ SVR-2301 ONLY	R1P108	2001-000449	R-CARBON:2.2KOHM,5%,1/8W,AA,TP,1.8X3.2M	
Q1SR01	0502-001050	TR-POWER:2SC4517A,NPN,30W,TO-220,ST,10-	SVR-2301 ONLY	R1P115	2001-000362	R-CARBON:150OHM,5%,1/8W,AA,TP,1.8X3.2MM	
Q1SR02	0501-000442	TR-SMALL SIGNAL:KTC3203-Y,NPN,400MW,TO-9	SVR-2301 ONLY	R1P116	2001-000734	R-CARBON:4.7KOHM,5%,1/8W,AA,TP,1.8X3.2M	
R1SD11	2001-000305	R-CARBON:110KOHM,5%,1/8W,AA,TP,1.8X3.2MM	SVR-2301 ONLY	R1P117	2001-000554	R-CARBON:270OHM,5%,1/8W,AA,TP,1.8X3.2MM	
R1SD12	2001-000869	R-CARBON:56OHM,5%,1/8W,AA,TP,1.8X3.2MM		R1P118	2001-000290	R-CARBON:10KOHM,5%,1/8W,AA,TP,1.8X3.2MM	
R1SD12	2001-000003	R-CARBON:330ohm,5%,1/8W,AA,TP,1.8x3.2mm	SVR-2301 ONLY	ZD1P01	0403-001211	DIODE-ZENER:MTZJ12B,11.44-12.03V,500MW,D	
R1SD13	2001-000076	R-CARBON:47KOHM,5%,1/4W,AA,TP,2.4X6.4MM		ZD1P02	0403-000717	DIODE-ZENER:MTZJ5.1B,5.1V,4.9-5.2V,500m	
R1SD13	2001-000305	R-CARBON:110KOHM,5%,1/8W,AA,TP,1.8X3.2MM	SVR-2301 ONLY	ZD1P03	0403-000720	DIODE-ZENER:MTZJ9.1B,9.1V,8.57-9.01V,500	
R1SD14	2001-000076	R-CARBON:47KOHM,5%,1/4W,AA,TP,2.4X6.4MM					
R1SD14	2001-000305	R-CARBON:110KOHM,5%,1/8W,AA,TP,1.8X3.2MM	SVR-2301 ONLY				
R1SD15	2001-000076	R-CARBON:47KOHM,5%,1/4W,AA,TP,2.4X6.4MM					
R1SD15	2001-000305	R-CARBON:110KOHM,5%,1/8W,AA,TP,1.8X3.2MM	SVR-2301 ONLY				
R1SD16	2003-000994	R-METAL OXIDE(S):33Kohm,5%,2W,AF,TP,3.9x					

Electrical Parts List

Loc.No	Part No	Description ; Specification	Remark	Loc.No	Part No	Description ; Specification	Remark
SYSTEM CONTROL/SERVO PARTS				R641	2001-000780	R-CARBON:470OHM,5%,1/8W,AA,TP,1.8X3.2MM	
C601	2202-002037	C-CERAMIC,MLC-AXIAL:100nF,80-20%,50V,Y5V		R642	2001-000780	R-CARBON:470OHM,5%,1/8W,AA,TP,1.8X3.2MM	
C602	2202-002037	C-CERAMIC,MLC-AXIAL:100nF,80-20%,50V,Y5V		R644	2001-000429	R-CARBON:1KOHM,5%,1/8W,AA,TP,1.8X3.2MM	
C603	2401-001545	C-AL:47uf,20%,25V,GP,TP,6.3x7mm,2.5		R650	2003-000259	R-METAL OXIDE:3.90HM,5%,2W,AE,TP,6X16MM	
C604	2202-000797	C-CERAMIC,MLC-AXIAL:10NF,30%,16V,Y5S,TP,		R651	2001-000010	R-CARBON:68KOHM,5%,1/8W,AA,TP,1.8X3.2MM	
C605	2202-000797	C-CERAMIC,MLC-AXIAL:10NF,30%,16V,Y5S,TP,		R654	2001-000812	R-CARBON:5.6KOHM,5%,1/8W,AA,TP,1.8X3.2M	
C607	2401-000118	C-AL:1000uf,20%,10V,GP,TP,10x12.5,5	SVR-131 NOT USER	R655	2001-000786	R-CARBON:47KOHM,5%,1/8W,AA,TP,1.8X3.2MM	
C609	2202-002037	C-CERAMIC,MLC-AXIAL:100nF,80-20%,50V,Y5V		R656	2001-000241	R-CARBON:1.5KOHM,5%,1/8W,AA,TP,1.8X3.2M	
C610	2202-000797	C-CERAMIC,MLC-AXIAL:10NF,30%,16V,Y5S,TP,		R657	2001-000010	R-CARBON:68KOHM,5%,1/8W,AA,TP,1.8X3.2MM	SVR-131 NOT USER
C611	2301-000392	C-FILM,PEF:15nF,5%,50V,TP,6.5x8.5x3.2mm,		R660	2001-000786	R-CARBON:47KOHM,5%,1/8W,AA,TP,1.8X3.2MM	
C614	2401-001507	C-AL:47uf,20%,16V,GP,TP,6.3x5,5		R661	2001-000660	R-CARBON:33KOHM,5%,1/8W,AA,TP,1.8X3.2MM	
C615	2401-001507	C-AL:47uf,20%,16V,GP,TP,6.3x5,5		R666	2001-000290	R-CARBON:10KOHM,5%,1/8W,AA,TP,1.8X3.2MM	
C618	2401-001545	C-AL:47uf,20%,25V,GP,TP,6.3x7mm,2.5		R667	2001-000290	R-CARBON:10KOHM,5%,1/8W,AA,TP,1.8X3.2MM	
C619	2202-000797	C-CERAMIC,MLC-AXIAL:10NF,30%,16V,Y5S,TP,		R668	2001-000780	R-CARBON:470OHM,5%,1/8W,AA,TP,1.8X3.2MM	
C620	2202-000797	C-CERAMIC,MLC-AXIAL:10NF,30%,16V,Y5S,TP,		R669	2001-000780	R-CARBON:470OHM,5%,1/8W,AA,TP,1.8X3.2MM	
C621	2401-001545	C-AL:47uf,20%,25V,GP,TP,6.3x7mm,2.5		R670	2001-000734	R-CARBON:4.7KOHM,5%,1/8W,AA,TP,1.8X3.2M	
C622	2301-001006	C-FILM,PEF:68nF,5%,50V,TP,8x4x8.5mm,5mm		R671	2001-000734	R-CARBON:4.7KOHM,5%,1/8W,AA,TP,1.8X3.2M	
C623	2202-000807	C-CERAMIC,MLC-AXIAL:22nF,+80-20%,25V,Y5V		R672	2001-000734	R-CARBON:4.7KOHM,5%,1/8W,AA,TP,1.8X3.2M	
C624	2202-000205	C-CERAMIC,MLC-AXIAL:22pF,5%,50V,SL,TP,1.	SVR-131 NOT USER	R674	2001-000290	R-CARBON:10KOHM,5%,1/8W,AA,TP,1.8X3.2MM	
C625	2202-000205	C-CERAMIC,MLC-AXIAL:22pF,5%,50V,SL,TP,1.	SVR-131 NOT USER	R675	2001-000032	R-CARBON:180OHM,5%,1/4W,AA,TP,2.4X6.4MM	
C626	2202-000205	C-CERAMIC,MLC-AXIAL:22pF,5%,50V,SL,TP,1.		R676	2001-000633	R-CARBON:30KOHM,5%,1/8W,AA,TP,1.8X3.2MM	
C627	2202-000205	C-CERAMIC,MLC-AXIAL:22pF,5%,50V,SL,TP,1.		R677	2001-000522	R-CARBON:22KOHM,5%,1/8W,AA,TP,1.8X3.2MM	
C633	2202-000797	C-CERAMIC,MLC-AXIAL:10NF,30%,16V,Y5S,TP,		R678	2001-000522	R-CARBON:22KOHM,5%,1/8W,AA,TP,1.8X3.2MM	
C634	2202-000797	C-CERAMIC,MLC-AXIAL:10NF,30%,16V,Y5S,TP,		R679	2001-000515	R-CARBON:220OHM,5%,1/8W,AA,TP,1.8X3.2MM	
C635	2202-000183	C-CERAMIC,MLC-AXIAL:2.2NF,20%,16V,Y5R,TP		R682	2001-000522	R-CARBON:22KOHM,5%,1/8W,AA,TP,1.8X3.2MM	
C636	2202-000183	C-CERAMIC,MLC-AXIAL:2.2NF,20%,16V,Y5R,TP		R685	2001-000660	R-CARBON:33KOHM,5%,1/8W,AA,TP,1.8X3.2MM	
C637	2202-000263	C-CERAMIC,MLC-AXIAL:470pF,10%,50V,Y5P,TP		R686	2001-000429	R-CARBON:1KOHM,5%,1/8W,AA,TP,1.8X3.2MM	
C638	2401-000922	C-AL:22uf,20%,16V,GP,TP,5x5,5		R687	2001-000429	R-CARBON:1KOHM,5%,1/8W,AA,TP,1.8X3.2MM	
C639	2202-000121	C-CERAMIC,MLC-AXIAL:100pF,10%,50V,Y5P,TP		R688	2001-000429	R-CARBON:1KOHM,5%,1/8W,AA,TP,1.8X3.2MM	
C640	2401-001507	C-AL:47uf,20%,16V,GP,TP,6.3x5,5		R690	2001-000864	R-CARBON:56KOHM,5%,1/8W,AA,TP,1.8X3.2MM	
C641	2401-002165	C-AL:100uf,20%,16V,GP,TP,6.3x7,5		R691	2001-000515	R-CARBON:220OHM,5%,1/8W,AA,TP,1.8X3.2MM	
C644	2202-000806	C-CERAMIC,MLC-AXIAL:220pF,10%,50V,Y5P,TP		R692	2001-000568	R-CARBON:270HM,5%,1/8W,AA,TP,1.8X3.2MM	SVR-131 NOT USER
C646	2202-002037	C-CERAMIC,MLC-AXIAL:100nF,80-20%,50V,Y5V		R693	2001-000734	R-CARBON:4.7KOHM,5%,1/8W,AA,TP,1.8X3.2M	
C679	2202-000807	C-CERAMIC,MLC-AXIAL:22nF,+80-20%,25V,Y5V		R696	2001-000780	R-CARBON:470OHM,5%,1/8W,AA,TP,1.8X3.2MM	
C689	2202-000791	C-CERAMIC,MLC-AXIAL:150pF,10%,50V,Y5P,TP		RS601	AC34-20100B	SWITCH-REC:-,X-9,-	
C690	2301-001006	C-FILM,PEF:68nF,5%,50V,TP,8x4x8.5mm,5mm		S601	0603-001011	PHOTO-TR:NPN,35V,6V,50mA,75mW,BK	
C691	2202-000797	C-CERAMIC,MLC-AXIAL:10NF,30%,16V,Y5S,TP,		S602	0603-001011	PHOTO-TR:NPN,35V,6V,50mA,75mW,BK	
C693	2401-000118	C-AL:1000uf,20%,10V,GP,TP,10x12.5,5		SW601	AC34-20100A	SWITCH-MODE:-,X-9,-	
CN601	AC39-20817S	LEAD CONNECTOR-ASSY:DP,SMH200-02,YBH200-		W117	2001-000281	R-CARBON:100OHM,5%,1/8W,AA,TP,1.8X3.2MM	
CN602	3708-001163	CONNECTOR-FPC/FPC/PIC:5P,1.25mm,STRAIGHT,		W128	2001-000281	R-CARBON:100OHM,5%,1/8W,AA,TP,1.8X3.2MM	
CN604	3711-003749	CONNECTOR-HEADER-BOX,8P,2R,2mm,STRAIGHT,		W173	2001-000429	R-CARBON:1KOHM,5%,1/8W,AA,TP,1.8X3.2MM	
D601	0402-000127	DIODE-RECTIFIER:1N4002,100V,1A,DO-41,TP		W174	2001-000429	R-CARBON:1KOHM,5%,1/8W,AA,TP,1.8X3.2MM	
D603	0401-000101	DIODE-SWITCHING:1N4148,100V,200mA,DO-35,		W250	2001-000429	R-CARBON:1KOHM,5%,1/8W,AA,TP,1.8X3.2MM	
D604	0401-000101	DIODE-SWITCHING:1N4148,100V,200mA,DO-35,		W300	2001-000429	R-CARBON:1KOHM,5%,1/8W,AA,TP,1.8X3.2MM	
D606	0401-000101	DIODE-SWITCHING:1N4148,100V,200mA,DO-35,		XT601	2801-003318	CRYSTAL-UNIT:32.768KHz,20ppm,28-AAP,12.5	SVR-131 NOT USER
D610	0401-000101	DIODE-SWITCHING:1N4148,100V,200mA,DO-35,		XT602	2801-003139	CRYSTAL-UNIT:8MHz,50ppm,28-AAA,22pF,80oh	
D612	0402-000127	DIODE-RECTIFIER:1N4002,100V,1A,DO-41,TP		AUDIO/VIDEO PARTS			
IC601	AC09-00089A	IC-MICOM:uPD784927GF-159-3BA,784927GF-1		C301	2401-001919	C-AL:2.2uf,20%,50V,-,TP,4x7mm,5	
IC601	AC09-00102A	IC-MICOM:uPD784927GF-153-3BA,784927GF-1	SVR-131 ONLY	C302	2301-000283	C-FILM,PEF:47nF,5%,100V,TP,7.3X7X3.2X5,5	
IC602	1003-001162	IC-MOTOR DRIVER:KA3082,SIP,10PIN,25MIL,D		C303	2401-001915	C-AL:1uf,20%,50V,GP,TP,3x5,5	
IC604	AC14-12006C	IC:KA7533,DIP,-		C304	2202-000216	C-CERAMIC,MLC-AXIAL:027NF,5%,50V,SL,TP,	
IC605	1103-001148	IC-EEPROM:24C021,2KBIT,DIP,8P,300MIL,10M		C305	2202-000164	C-CERAMIC,MLC-AXIAL:18NF,10%,50V,Y5P,TP	
IC608	1203-000515	IC-VOL. DETECTOR:7042,TO-92,3P,177MIL,PL	SVR-131 NOT USER	C306	2202-000231	C-CERAMIC,MLC-AXIAL:330pF,10%,50V,Y5P,TP	
L601	2701-000002	INDUCTOR-AXIAL:100uH,10%,4.2x9.8mm		C307	2202-000162	C-CERAMIC,MLC-AXIAL:015NF,5%,50V,SL,TP,	
L602	2701-000002	INDUCTOR-AXIAL:100uH,10%,4.2x9.8mm		C308	2202-000797	C-CERAMIC,MLC-AXIAL:10NF,30%,16V,Y5S,TP,	
L603	2701-000002	INDUCTOR-AXIAL:100uH,10%,4.2x9.8mm		C309	2401-001915	C-AL:1uf,20%,50V,GP,TP,3x5,5	
L604	2701-000002	INDUCTOR-AXIAL:100uH,10%,4.2x9.8mm		C310	2401-000407	C-AL:10uf,20%,16V,GP,TP,3.5x5,2.5	
LD601	0601-000517	LED-IR-RECTANGULA,4x6.0mm,75mW,6V,950		C311	2401-000922	C-AL:22uf,20%,16V,GP,TP,5x5,5	
PT601	0604-001122	PHOTO-INTERRUPTER:TR,0.065%,150mW,DIP-4,		C313	2202-000173	C-CERAMIC,MLC-AXIAL:1nF,10%,50V,Y5P,TP,1	
PT602	0604-001122	PHOTO-INTERRUPTER:TR,0.065%,150mW,DIP-4,		C314	2401-001775	C-AL:470nF,20%,50V,GP,TP,4x7,5	
O602	0501-000398	TR-SMALL SIGNAL:XSC945,NPN,250mW,TO-92,T		C315	2401-000407	C-AL:10uf,20%,16V,GP,TP,3.5x5,2.5	
R608	2001-000864	R-CARBON:56KOHM,5%,1/8W,AA,TP,1.8X3.2MM		C316	2202-002037	C-CERAMIC,MLC-AXIAL:100nF,80-20%,50V,Y5V	
R609	2001-000864	R-CARBON:56KOHM,5%,1/8W,AA,TP,1.8X3.2MM		C318	2202-002037	C-CERAMIC,MLC-AXIAL:100nF,80-20%,50V,Y5V	
R613	2001-000429	R-CARBON:1KOHM,5%,1/8W,AA,TP,1.8X3.2MM	SVR-131 NOT USER	C320	2401-001915	C-AL:1uf,20%,50V,GP,TP,3x5,5	
R614	2001-000429	R-CARBON:1KOHM,5%,1/8W,AA,TP,1.8X3.2MM		C321	2401-000407	C-AL:10uf,20%,16V,GP,TP,3.5x5,2.5	

ULP : ULTRA LONG PLAY

Loc.No	Part No	Description ; Specification	Remark	Loc.No	Part No	Description ; Specification	Remark
C322	2401-001915	C-AL:1uF,20%,50V,GP,TP,3x5,5		L303	2701-000002	INDUCTOR-AXIAL:100uH,10%,4.2x9.8mm	
C323	2202-000797	C-CERAMIC,MLC-AXIAL:10NF,30%,16V,Y5S,TP,		L304	2701-000002	INDUCTOR-AXIAL:100uH,10%,4.2x9.8mm	
C324	2202-000797	C-CERAMIC,MLC-AXIAL:10NF,30%,16V,Y5S,TP,		L306	2701-000119	INDUCTOR-AXIAL:120uH,5%,2.4x3.4mm	
C325	2202-000797	C-CERAMIC,MLC-AXIAL:10NF,30%,16V,Y5S,TP,		L307	2701-000122	INDUCTOR-AXIAL:12uH,5%,2.4x3.4mm	
C326	2202-002037	C-CERAMIC,MLC-AXIAL:100nF,80-20%,50V,Y5V		L3A01	2702-000120	INDUCTOR-RADIAL:15mH,5%,6.2x7.4mm	
C327	2401-001507	C-AL:47uF,20%,16V,GP,TP,6.3x5,5		L3A02	2702-000106	INDUCTOR-RADIAL:100uH,10%,6.2x7.4mm	
C328	2202-000797	C-CERAMIC,MLC-AXIAL:10NF,30%,16V,Y5S,TP,		L3A03	2701-000002	INDUCTOR-AXIAL:100uH,10%,4.2x9.8mm	
C329	2202-000797	C-CERAMIC,MLC-AXIAL:10NF,30%,16V,Y5S,TP,		L3A04	2702-000106	INDUCTOR-RADIAL:100uH,10%,6.2x7.4mm	
C330	2202-000797	C-CERAMIC,MLC-AXIAL:10NF,30%,16V,Y5S,TP,		Q302	0501-000303	TR-SMALL SIGNAL:KSA733,PNP,250mW,TO-92,T	
C331	2401-001507	C-AL:47uF,20%,16V,GP,TP,6.3x5,5		Q303	0501-000398	TR-SMALL SIGNAL:KSC945,NPN,250mW,TO-92,T	
C332	2202-002037	C-CERAMIC,MLC-AXIAL:100nF,80-20%,50V,Y5V		Q304	0501-000398	TR-SMALL SIGNAL:KSC945,NPN,250mW,TO-92,T	
C333	2401-001915	C-AL:1uF,20%,50V,GP,TP,3x5,5		Q308	0501-000398	TR-SMALL SIGNAL:KSC945,NPN,250mW,TO-92,T	
C334	2202-002055	C-CERAMIC,MLC-AXIAL:47nF,+80-20%,50V,Y5V		Q309	0501-000398	TR-SMALL SIGNAL:KSC945,NPN,250mW,TO-92,T	
C335	2401-001915	C-AL:1uF,20%,50V,GP,TP,3x5,5		Q3A01	0501-000303	TR-SMALL SIGNAL:KSA733,PNP,250mW,TO-92,T	
C336	2401-001915	C-AL:1uF,20%,50V,GP,TP,3x5,5		Q3A03	0501-000442	TR-SMALL SIGNAL:KTC3203-Y,NPN,400mW,TO-9	
C337	2202-000807	C-CERAMIC,MLC-AXIAL:22nF,+80-20%,25V,Y5V		Q3A04	0501-000442	TR-SMALL SIGNAL:KTC3203-Y,NPN,400mW,TO-9	
C338	2202-000797	C-CERAMIC,MLC-AXIAL:10NF,30%,16V,Y5S,TP,		Q3A05	0501-000442	TR-SMALL SIGNAL:KTC3203-Y,NPN,400mW,TO-9	
C339	2202-002055	C-CERAMIC,MLC-AXIAL:47nF,+80-20%,50V,Y5V		Q3A06	0501-000303	TR-SMALL SIGNAL:KSA733,PNP,250mW,TO-92,T	
C340	2202-000807	C-CERAMIC,MLC-AXIAL:22nF,+80-20%,25V,Y5V		R301	2001-000449	R-CARBON:2.2KOHM,5%,1/8W,AA,TP,1.8X3.2MM	
C341	2401-002144	C-AL:47uF,20%,16V,GP,TP,5x11,5		R302	2001-000429	R-CARBON:1KOHM,5%,1/8W,AA,TP,1.8X3.2MM	
C342	2202-002037	C-CERAMIC,MLC-AXIAL:100nF,80-20%,50V,Y5V		R303	2001-000258	R-CARBON:1.8KOHM,5%,1/8W,AA,TP,1.8X3.2MM	
C343	2202-000797	C-CERAMIC,MLC-AXIAL:10NF,30%,16V,Y5S,TP,		R304	2001-000977	R-CARBON:8.2KOHM,5%,1/8W,AA,TP,1.8X3.2MM	
C345	2201-002031	C-CERAMIC,DISC:0.005nF,0.5pF,50V,NPO,TP,		R306	2001-000232	R-CARBON:1.3KOHM,5%,1/8W,AA,TP,1.8X3.2MM	
C346	2401-001507	C-AL:47uF,20%,16V,GP,TP,6.3x5,5		R308	2001-000429	R-CARBON:1KOHM,5%,1/8W,AA,TP,1.8X3.2MM	
C347	2202-000286	C-CERAMIC,MLC-AXIAL:56pF,5%,50V,SL,TP,1.		R309	2001-000723	R-CARBON:4.3KOHM,5%,1/8W,AA,TP,1.8X3.2MM	
C348	2202-000286	C-CERAMIC,MLC-AXIAL:56pF,5%,50V,SL,TP,1.		R311	2001-000429	R-CARBON:1KOHM,5%,1/8W,AA,TP,1.8X3.2MM	
C349	2202-000849	C-CERAMIC,MLC-AXIAL:18pF,5%,50V,CH,TP,3.		R312	2001-000221	R-CARBON:1.2KOHM,5%,1/8W,AA,TP,1.8X3.2MM	
C350	2202-000797	C-CERAMIC,MLC-AXIAL:10NF,30%,16V,Y5S,TP,		R313	2001-000515	R-CARBON:220OHM,5%,1/8W,AA,TP,1.8X3.2MM	
C380	2202-000243	C-CERAMIC,MLC-AXIAL:33pF,5%,50V,SL,TP,1.		R314	2001-000924	R-CARBON:680OHM,5%,1/8W,AA,TP,1.8X3.2MM	
C381	2202-000797	C-CERAMIC,MLC-AXIAL:10NF,30%,16V,Y5S,TP,		R315	2001-000472	R-CARBON:2.7KOHM,5%,1/8W,AA,TP,1.8X3.2MM	
C390	2202-002037	C-CERAMIC,MLC-AXIAL:100nF,80-20%,50V,Y5V		R316	2001-000221	R-CARBON:1.2KOHM,5%,1/8W,AA,TP,1.8X3.2MM	
C391	2202-000121	C-CERAMIC,MLC-AXIAL:100pF,10%,50V,Y5P,TP		R317	2001-000003	R-CARBON:330ohm,5%,1/8W,AA,TP,1.8x3.2mm	
C393	2202-000787	C-CERAMIC,MLC-AXIAL:10PF,5%,50V,Y5P,TP,3		R318	2001-000003	R-CARBON:330ohm,5%,1/8W,AA,TP,1.8x3.2mm	
C395	2202-002037	C-CERAMIC,MLC-AXIAL:100nF,80-20%,50V,Y5V		R320	2001-000290	R-CARBON:10KOHM,5%,1/8W,AA,TP,1.8X3.2MM	
C398	2202-000205	C-CERAMIC,MLC-AXIAL:22pF,5%,50V,SL,TP,1.		R321	2001-000009	R-CARBON:20KOHM,5%,1/8W,AA,TP,1.8X3.2MM	
C3A01	2401-002299	C-AL:4.7uF,20%,50V,GP,TP,5x7,5		R322	2001-000539	R-CARBON:24KOHM,5%,1/8W,AA,TP,1.8X3.2MM	
C3A02	2202-002037	C-CERAMIC,MLC-AXIAL:100nF,80-20%,50V,Y5V		R325	2001-000472	R-CARBON:2.7KOHM,5%,1/8W,AA,TP,1.8X3.2MM	
C3A04	2202-002037	C-CERAMIC,MLC-AXIAL:100nF,80-20%,50V,Y5V		R326	2001-000832	R-CARBON:510OHM,5%,1/8W,AA,TP,1.8X3.2MM	
C3A07	2301-000392	C-FILM,PEF:15nF,5%,50V,TP,6.5x8.5x3.2mm,		R327	2001-000832	R-CARBON:510OHM,5%,1/8W,AA,TP,1.8X3.2MM	
C3A08	2301-001014	C-FILM,PEF:6.8nF,5%,50V,TP,7x3x6,5mm		R328	2001-000734	R-CARBON:4.7KOHM,5%,1/8W,AA,TP,1.8X3.2M	
C3A09	2301-001014	C-FILM,PEF:6.8nF,5%,50V,TP,7x3x6,5mm		R329	2001-000472	R-CARBON:2.7KOHM,5%,1/8W,AA,TP,1.8X3.2M	4H'D ONLY
C3A10	2301-000314	C-FILM,PEF:8.2nF,5%,50V,TP,6.5x3.0x5.5mm		R330	2001-000734	R-CARBON:4.7KOHM,5%,1/8W,AA,TP,1.8X3.2M	
C3A11	2301-000253	C-FILM,PEF:39nF,5%,100V,TP,7.5X4.5X12.5MM		R331	2001-000515	R-CARBON:220OHM,5%,1/8W,AA,TP,1.8X3.2MM	
C3A12	2401-002144	C-AL:47uF,20%,16V,GP,TP,5x11,5		R332	2001-000281	R-CARBON:100OHM,5%,1/8W,AA,TP,1.8X3.2MM	
C3A13	2301-000161	C-FILM,PEF:12nF,5%,50V,TP,6.5X5.5X3.0X5,		R333	2001-000281	R-CARBON:100OHM,5%,1/8W,AA,TP,1.8X3.2MM	
C3A14	2301-001014	C-FILM,PEF:6.8nF,5%,50V,TP,7x3x6,5mm		R334	2001-000281	R-CARBON:100OHM,5%,1/8W,AA,TP,1.8X3.2MM	
C3A15	2301-000381	C-FILM,PEF:10nF,5%,50V,TP,6.5x5.5x3mm,5m		R335	2001-000800	R-CARBON:5.1KOHM,5%,1/8W,AA,TP,1.8X3.2M	
C3A16	2401-002299	C-AL:4.7uF,20%,50V,GP,TP,5x7,5		R336	2001-000008	R-CARBON:15KOHM,5%,1/8W,AA,TP,1.8X3.2MM	
C3A17	2401-000922	C-AL:22uF,20%,16V,GP,TP,5x5,5		R337	2001-001000	R-CARBON:82KOHM,5%,1/8W,AA,TP,1.8X3.2MM	
C3A18	2301-000402	C-FILM,PEF:1nF,5%,50V,TP,5x7x2.8mm,5mm		R342	2001-000812	R-CARBON:5.6KOHM,5%,1/8W,AA,TP,1.8X3.2M	
C3A21	2301-000008	C-FILM,PEF:2.2nF,5%,50V,TP,5.5X7X3.5mm		R346	2001-000258	R-CARBON:1.8KOHM,5%,1/8W,AA,TP,1.8X3.2M	
C3A22	2202-002037	C-CERAMIC,MLC-AXIAL:100nF,80-20%,50V,Y5V		R3A01	2001-000331	R-CARBON:12KOHM,5%,1/8W,AA,TP,1.8X3.2MM	
C3A23	2401-001169	C-AL:33uF,20%,16V,GP,-,6.3x7.2,5mm		R3A04	2001-000241	R-CARBON:1.5KOHM,5%,1/8W,AA,TP,1.8X3.2M	
C3A24	2202-002037	C-CERAMIC,MLC-AXIAL:100nF,80-20%,50V,Y5V		R3A05	2001-000660	R-CARBON:33KOHM,5%,1/8W,AA,TP,1.8X3.2MM	
C3A25	2401-000922	C-AL:22uF,20%,16V,GP,TP,5x5,5		R3A06	2001-000325	R-CARBON:120OHM,5%,1/8W,AA,TP,1.8X3.2MM	
C3A29	2202-002037	C-CERAMIC,MLC-AXIAL:100nF,80-20%,50V,Y5V		R3A07	2001-000645	R-CARBON:330KOHM,5%,1/8W,AA,TP,1.8X3.2M	
C3A30	2401-002144	C-AL:47uF,20%,16V,GP,TP,5x11,5		R3A08	2001-000331	R-CARBON:12KOHM,5%,1/8W,AA,TP,1.8X3.2MM	
C3A31	2202-002037	C-CERAMIC,MLC-AXIAL:100nF,80-20%,50V,Y5V		R3A09	2001-000812	R-CARBON:5.6KOHM,5%,1/8W,AA,TP,1.8X3.2M	
CN301	3708-000395	CONNECTOR-FPC/FC/PIC:8P,1.25MM,STRAIGHT,		R3A10	2001-000429	R-CARBON:1KOHM,5%,1/8W,AA,TP,1.8X3.2MM	
CN3A01	3708-001302	CONNECTOR-FPC/FC/PIC:7P,1.25mm,STRAIGHT,		R3A11	2001-000258	R-CARBON:1.8KOHM,5%,1/8W,AA,TP,1.8X3.2M	
CN3A02	3711-002445	CONNECTOR-HEADER:BOX,2P,2R,1.5MM,STRAIGH		R3A12	2001-000458	R-CARBON:2.2OHM,5%,1/8W,AA,TP,1.8X3.2MM	
D302	0401-000101	DIODE-SWITCHING:1N4148,100V,200mA,DO-35,		R3A13	2001-000780	R-CARBON:470OHM,5%,1/8W,AA,TP,1.8X3.2MM	
FL3A01	AC27-80100A	COIL-OSC:126QN-K5272YHC-K,-,AM		R3A14	2001-000522	R-CARBON:22KOHM,5%,1/8W,AA,TP,1.8X3.2MM	
IC301	1204-001649	IC-VIDEO PROCESS:LA71598M,QFP,100P,-,PLA		R3A15	2001-000411	R-CARBON:18KOHM,5%,1/8W,AA,TP,1.8X3.2MM	
L301	2701-000206	INDUCTOR-AXIAL:56uH,5%,2.4x3.4mm		R3A16	2001-000290	R-CARBON:10KOHM,5%,1/8W,AA,TP,1.8X3.2MM	
L302	2701-000002	INDUCTOR-AXIAL:100uH,10%,4.2x9.8mm		R3A17	2001-000613	R-CARBON:3.9KOHM,5%,1/8W,AA,TP,1.8X3.2M	

Electrical Parts List

Loc.No	Part No	Description ; Specification	Remark	Loc.No	Part No	Description ; Specification	Remark
R3A18	2001-000613	R-CARBON:3.9KOHM,5%,1/8W,AA,TP,1.8X3.2MM		INPUT-OUTPUT PARTS			
R3A19	2001-000405	R-CARBON:180OHM,5%,1/8W,AA,TP,1.8X3.2MM		C801	2401-002144	C-AL:47uf,20%,16V,GP,TP,5x11.5	
R3A21	2001-000904	R-CARBON:620OHM,5%,1/8W,AA,TP,1.8X3.2MM		C802	2401-001479	C-AL:470uf,20%,10V,GP,TP,-	
R3A22	2001-000006	R-CARBON:2.4KOHM,5%,1/8W,AA,TP,1.8X3.2MM		C806	2202-000830	C-CERAMIC,MLC-AXIAL:82pf,10%,50V,Y5P,TP,	
R3A23	2001-000812	R-CARBON:5.6KOHM,5%,1/8W,AA,TP,1.8X3.2MM		C809	2401-002299	C-AL:4.7uf,20%,50V,GP,TP,5x7.5	
R3A24	2001-000522	R-CARBON:22KOHM,5%,1/8W,AA,TP,1.8X3.2MM		C810	2401-001074	C-AL:330nf,20%,50V,GP,TP,4x5.2.5mm	
R3A25	2001-000221	R-CARBON:1.2KOHM,5%,1/8W,AA,TP,1.8X3.2MM		C812	2202-000121	C-CERAMIC,MLC-AXIAL:100pf,10%,50V,Y5P,TP	
R3A26	2001-000331	R-CARBON:12KOHM,5%,1/8W,AA,TP,1.8X3.2MM		C813	2202-000173	C-CERAMIC,MLC-AXIAL:1nf,10%,50V,Y5P,TP,1	
R3A27	2001-000947	R-CARBON:7.5KOHM,5%,1/8W,AA,TP,1.8X3.2MM		C814	2202-000121	C-CERAMIC,MLC-AXIAL:100pf,10%,50V,Y5P,TP	
R3A28	2001-000890	R-CARBON:6.8KOHM,5%,1/8W,AA,TP,1.8X3.2MM		JC801	AC37-20001H	JACK-RCA:DPAM-4P,MONO,PI3.3	
R3A29	2001-000890	R-CARBON:6.8KOHM,5%,1/8W,AA,TP,1.8X3.2MM		L801	2701-000181	INDUCTOR-AXIAL:33uH,5%,2.4x3.4mm	
R3A30	2001-000454	R-CARBON:2.2MOHM,5%,1/8W,AA,TP,1.8X3.2MM		L802	2701-000181	INDUCTOR-AXIAL:33uH,5%,2.4x3.4mm	
R3A31	2001-000766	R-CARBON:43KOHM,5%,1/8W,AA,TP,1.8X3.2MM		R801	2001-000449	R-CARBON:2.2KOHM,5%,1/8W,AA,TP,1.8X3.2MM	
R3A32	2001-000766	R-CARBON:43KOHM,5%,1/8W,AA,TP,1.8X3.2MM		R802	2001-000995	R-CARBON:820OHM,5%,1/8W,AA,TP,1.8X3.2MM	
R3A33	2001-000766	R-CARBON:43KOHM,5%,1/8W,AA,TP,1.8X3.2MM		R803	2001-000221	R-CARBON:1.2KOHM,5%,1/8W,AA,TP,1.8X3.2MM	
R3A37	2001-000947	R-CARBON:7.5KOHM,5%,1/8W,AA,TP,1.8X3.2MM		R806	2001-000969	R-CARBON:750HM,5%,1/8W,AA,TP,1.8X3.2MM	
XT301	2801-001397	CRYSTAL-UNIT:4.433619MHZ,HC-49/U-S 15PPM		R808	2001-000969	R-CARBON:750HM,5%,1/8W,AA,TP,1.8X3.2MM	
R324	2001-000554	R-CARBON:270OHM,5%,1/8W,AA,TP,1.8X3.2MM	SVR-433 NOT USER	R809	2001-000969	R-CARBON:750HM,5%,1/8W,AA,TP,1.8X3.2MM	
Q307	0504-000119	TR-DIGITAL:KSR1004,NPN,300MW,47K/47K,TO-	SVR-433 NOT USER	R810	2001-000554	R-CARBON:270OHM,5%,1/8W,AA,TP,1.8X3.2MM	
R329	2001-000734	R-CARBON:4.7KOHM,5%,1/8W,AA,TP,1.8X3.2MM	2H D ONLY	FUNCTION MATRIX PARTS			
TM-BLOCK				CN703	3708-001163	CONNECTOR-FPC/FC/PIC:5P,1.25mm,STRAIGHT,	
C401	2401-002144	C-AL:47uf,20%,16V,GP,TP,5x11.5		CN708	3711-004013	CONNECTOR-HEADER:3WALL,10P,1R,2mm,STRAIG	
C402	2202-000807	C-CERAMIC,MLC-AXIAL:22nf,+80-20%,25V,Y5V		D701	0401-000101	DIODE-SWITCHING:1N4148,100V,200mA,DO-35,	
C403	2401-002144	C-AL:47uf,20%,16V,GP,TP,5x11.5		D702	0401-000101	DIODE-SWITCHING:1N4148,100V,200mA,DO-35,	
C404	2202-000807	C-CERAMIC,MLC-AXIAL:22nf,+80-20%,25V,Y5V		D703	0401-000101	DIODE-SWITCHING:1N4148,100V,200mA,DO-35,	
C405	2401-001573	C-AL:47uf,20%,50V,GP,TP,6.3x11.2.5		D704	0401-000101	DIODE-SWITCHING:1N4148,100V,200mA,DO-35,	
C406	2202-000807	C-CERAMIC,MLC-AXIAL:22nf,+80-20%,25V,Y5V		D705	0401-000101	DIODE-SWITCHING:1N4148,100V,200mA,DO-35,	
C407	2401-001085	C-AL:330nf,20%,50V,GP,5x9,2mm		D706	0401-000101	DIODE-SWITCHING:1N4148,100V,200mA,DO-35,	
D401	0402-000127	DIODE-RECTIFIER:1N4002,100V,1A,DO-41,TP		D708	0401-000101	DIODE-SWITCHING:1N4148,100V,200mA,DO-35,	
L401	2701-000002	INDUCTOR-AXIAL:100uH,10%,4.2x9.8mm		D709	0401-000101	DIODE-SWITCHING:1N4148,100V,200mA,DO-35,	
L402	2701-000002	INDUCTOR-AXIAL:100uH,10%,4.2x9.8mm		D720	0401-000101	DIODE-SWITCHING:1N4148,100V,200mA,DO-35,	
R401	2001-000786	R-CARBON:47KOHM,5%,1/8W,AA,TP,1.8X3.2MM		Q701	0501-000398	TR-SMALL SIGNAL:KSC945,NPN,250mW,TO-92,T	
R402	2001-000281	R-CARBON:100OHM,5%,1/8W,AA,TP,1.8X3.2MM		Q702	0501-000398	TR-SMALL SIGNAL:KSC945,NPN,250mW,TO-92,T	
R403	2001-000281	R-CARBON:100OHM,5%,1/8W,AA,TP,1.8X3.2MM		Q703	0501-000398	TR-SMALL SIGNAL:KSC945,NPN,250mW,TO-92,T	
R404	2001-000281	R-CARBON:100OHM,5%,1/8W,AA,TP,1.8X3.2MM		Q704	0501-000398	TR-SMALL SIGNAL:KSC945,NPN,250mW,TO-92,T	
TM401	AC40-00001G	TM-BLOCK:TCMK0600PD11A,G/I/K(MONO),TCMK		Q705	0501-000398	TR-SMALL SIGNAL:KSC945,NPN,250mW,TO-92,T	
TM401	AC40-20100L	RF-MODULATOR:RMUP74055VC,VCP PAL	SVR-131 ONLY	Q708	0501-000398	TR-SMALL SIGNAL:KSC945,NPN,250mW,TO-92,T	SVR-433 ONLY
ZD401	0403-000390	DIODE-ZENER:UZP33B,33V,31.4-34.6V,1W,DO-		Q711	0501-000290	TR-SMALL SIGNAL:KSA643-Y,PNP,500mW,TO-92	SVR-433 ONLY
O.S.D. PARTS				Q712	0501-000290	TR-SMALL SIGNAL:KSA643-Y,PNP,500mW,TO-92	SVR-433 ONLY
C6P01	2202-000797	C-CERAMIC,MLC-AXIAL:10NF,30%,16V,Y5S,TP,		Q713	0501-000290	TR-SMALL SIGNAL:KSA643-Y,PNP,500mW,TO-92	SVR-433 ONLY
C6P02	2401-002144	C-AL:47uf,20%,16V,GP,TP,5x11.5		Q714	0501-000290	TR-SMALL SIGNAL:KSA643-Y,PNP,500mW,TO-92	SVR-433 ONLY
C6P03	2202-002037	C-CERAMIC,MLC-AXIAL:100nf,80-20%,50V,Y5V		Q715	0501-000290	TR-SMALL SIGNAL:KSA643-Y,PNP,500mW,TO-92	SVR-433 ONLY
C6P04	2202-000243	C-CERAMIC,MLC-AXIAL:33pf,5%,50V,SL,TP,3.		R701	2001-000290	R-CARBON:10KOHM,5%,1/8W,AA,TP,1.8X3.2MM	
C6P05	2202-000216	C-CERAMIC,MLC-AXIAL:027NF,5%,50V,SL,TP,		R702	2001-000290	R-CARBON:10KOHM,5%,1/8W,AA,TP,1.8X3.2MM	
C6P08	2202-000286	C-CERAMIC,MLC-AXIAL:56pf,5%,50V,SL,TP,1.		R703	2001-000290	R-CARBON:10KOHM,5%,1/8W,AA,TP,1.8X3.2MM	
C6P09	2202-000145	C-CERAMIC,MLC-AXIAL:12NF,10%,50V,Y5P,TP		R704	2001-000290	R-CARBON:10KOHM,5%,1/8W,AA,TP,1.8X3.2MM	
C6P10	2401-001915	C-AL:1uf,20%,50V,GP,TP,3x5.5		R705	2001-000290	R-CARBON:10KOHM,5%,1/8W,AA,TP,1.8X3.2MM	
C6P11	2401-001915	C-AL:1uf,20%,50V,GP,TP,3x5.5		R706	2001-000290	R-CARBON:10KOHM,5%,1/8W,AA,TP,1.8X3.2MM	
C6P12	2401-002144	C-AL:47uf,20%,16V,GP,TP,5x11.5		R707	2001-000290	R-CARBON:10KOHM,5%,1/8W,AA,TP,1.8X3.2MM	
C6P13	2202-002037	C-CERAMIC,MLC-AXIAL:100nf,80-20%,50V,Y5V		R708	2001-000290	R-CARBON:10KOHM,5%,1/8W,AA,TP,1.8X3.2MM	SVR-433 ONLY
IC6P01	AC09-00078A	IC-OSD:LC74759JM-9785,LC74759JM-9785,		R711	2001-000449	R-CARBON:2.2KOHM,5%,1/8W,AA,TP,1.8X3.2MM	SVR-433 ONLY
IC6P01	AC09-10458R	IC-MCU:LC74783JM-9745,24P,MFP,OSD IC,-	SVR-131 ONLY	R712	2001-000449	R-CARBON:2.2KOHM,5%,1/8W,AA,TP,1.8X3.2MM	SVR-433 ONLY
L6P03	2701-000160	INDUCTOR-AXIAL:22uH,5%,2.4x3.4mm		R713	2001-000449	R-CARBON:2.2KOHM,5%,1/8W,AA,TP,1.8X3.2MM	SVR-433 ONLY
L6P05	2702-001077	INDUCTOR-RADIAL:27uH,5%,5.5x5.5mm		R714	2001-000449	R-CARBON:2.2KOHM,5%,1/8W,AA,TP,1.8X3.2MM	SVR-433 ONLY
Q6P01	0501-000303	TR-SMALL SIGNAL:KSA733,PNP,250mW,TO-92,T		R715	2001-000449	R-CARBON:2.2KOHM,5%,1/8W,AA,TP,1.8X3.2MM	SVR-433 ONLY
Q6P02	0501-000303	TR-SMALL SIGNAL:KSA733,PNP,250mW,TO-92,T		R716	2001-000449	R-CARBON:2.2KOHM,5%,1/8W,AA,TP,1.8X3.2MM	SVR-433 ONLY
R6P07	2001-000281	R-CARBON:100OHM,5%,1/8W,AA,TP,1.8X3.2MM		R718	2001-000969	R-CARBON:750HM,5%,1/8W,AA,TP,1.8X3.2MM	SVR-433 ONLY
R6P08	2001-000005	R-CARBON:390ohm,5%,1/8W,AA,TP,1.8x3.2mm		R718	2001-000362	R-CARBON:150OHM,5%,1/8W,AA,TP,1.8X3.2MM	SVR-433 NOT USER
R6P09	2001-000449	R-CARBON:2.2KOHM,5%,1/8W,AA,TP,1.8X3.2MM		R719	2001-000969	R-CARBON:750HM,5%,1/8W,AA,TP,1.8X3.2MM	SVR-433 ONLY
R6P10	2001-000290	R-CARBON:10KOHM,5%,1/8W,AA,TP,1.8X3.2MM	SVR-131 NOT USER	R719	2001-000362	R-CARBON:150OHM,5%,1/8W,AA,TP,1.8X3.2MM	SVR-433 NOT USER
				R720	2001-000969	R-CARBON:750HM,5%,1/8W,AA,TP,1.8X3.2MM	SVR-433 ONLY
				R720	2001-000362	R-CARBON:150OHM,5%,1/8W,AA,TP,1.8X3.2MM	SVR-433 NOT USER
				R721	2001-000969	R-CARBON:750HM,5%,1/8W,AA,TP,1.8X3.2MM	SVR-433 ONLY
				R721	2001-000362	R-CARBON:150OHM,5%,1/8W,AA,TP,1.8X3.2MM	SVR-433 NOT USER
				R722	2001-000969	R-CARBON:750HM,5%,1/8W,AA,TP,1.8X3.2MM	SVR-433 ONLY

Loc.No	Part No	Description ; Specification	Remark	Loc.No	Part No	Description ; Specification	Remark
R722	2001-000362	R-CARBON:150OHM,5%,1/8W,AA,TP,1.8X3.2MM	SVR-433 NOT USER	R730	2001-000780	R-CARBON:470OHM,5%,1/8W,AA,TP,1.8X3.2MM	
R723	2001-000969	R-CARBON:75OHM,5%,1/8W,AA,TP,1.8X3.2MM	SVR-433 ONLY	R731	2001-000290	R-CARBON:10KOHM,5%,1/8W,AA,TP,1.8X3.2MM	
R723	2001-000362	R-CARBON:150OHM,5%,1/8W,AA,TP,1.8X3.2MM	SVR-433 NOT USER	RM701	AC59-60060A	MODULE-REMOCON:GP1U281R,SHARP,38KHZ,-,-,	
R724	2001-000969	R-CARBON:75OHM,5%,1/8W,AA,TP,1.8X3.2MM	SVR-433 ONLY	-	-	ASSY-PCB-SUB:SHUTTLE	S.N.A.
R727	2001-000008	R-CARBON:15KOHM,5%,1/8W,AA,TP,1.8X3.2MM		CN707	3708-001164	CONNECTOR-FPC/FC/PIC:5P,1.25MM,ANGLE,SN	
R728	2001-000008	R-CARBON:15KOHM,5%,1/8W,AA,TP,1.8X3.2MM		SH701	2101-000101	VR-ROTARY:100Kohm,20%,1/10W,SIDE	
SW701	3404-001076	SWITCH-TACT:12V,50mA,16gf+-50gf,6x6mm,SP					
SW703	3404-001076	SWITCH-TACT:12V,50mA,16gf+-50gf,6x6mm,SP					
SW706	3404-000165	SWITCH-TACT:12V,50mA,160gf,6x6mm,SPST					
SW707	3404-000165	SWITCH-TACT:12V,50mA,160gf,6x6mm,SPST					
SW708	3404-001076	SWITCH-TACT:12V,50mA,16gf+-50gf,6x6mm,SP					
SW709	3404-001076	SWITCH-TACT:12V,50mA,16gf+-50gf,6x6mm,SP					
SW711	3404-001076	SWITCH-TACT:12V,50mA,16gf+-50gf,6x6mm,SP					
SW712	3404-001076	SWITCH-TACT:12V,50mA,16gf+-50gf,6x6mm,SP					
SW713	3404-001076	SWITCH-TACT:12V,50mA,16gf+-50gf,6x6mm,SP					
SW714	3404-001076	SWITCH-TACT:12V,50mA,16gf+-50gf,6x6mm,SP					
SW715	3404-001076	SWITCH-TACT:12V,50mA,16gf+-50gf,6x6mm,SP					
SW716	3404-001076	SWITCH-TACT:12V,50mA,16gf+-50gf,6x6mm,SP					
SW718	3404-000165	SWITCH-TACT:12V,50mA,160gf,6x6mm,SPST					
FRONT AV JACK (SVR-433/233 ONLY)							
C704	2401-000407	C-AL:10uF,20%,16V,GP,TP,3.5x5,2.5					
C706	2202-000173	C-CERAMIC,MLC-AXIAL:1nF,10%,50V,Y5P,TP,1					
CN709	3710-001385	CONNECTOR-SOCKET:10P,1R,2mm,ANGLE,SN					
D707	0401-000101	DIODE-SWITCHING:1N4148,100V,200mA,DO-35,					
JK701	AC37-22002J	JACK-PIN:3.2mm,DPSE-9814,2P,13mm,S/W					
L703	2701-000181	INDUCTOR-AXIAL:33uH,5%,2.4x3.4mm					
Q706	0501-000398	TR-SMALL SIGNAL:KSC945,NPN,250mW,TO-92,T					
Q707	0501-000398	TR-SMALL SIGNAL:KSC945,NPN,250mW,TO-92,T					
R735	2001-000969	R-CARBON:75OHM,5%,1/8W,AA,TP,1.8X3.2MM					
-	-	ASSY-PCB-F/TIMER:LED MODILE	S.N.A.				
C701	2401-002165	C-AL:100uF,20%,16V,GP,TP,6.3x7,5					
C702	2202-000797	C-CERAMIC,MLC-AXIAL:10NF,30%,16V,Y5S,TP,					
C703	2202-000173	C-CERAMIC,MLC-AXIAL:1nF,10%,50V,Y5P,TP,1					
CN705	3711-001198	CONNECTOR-HEADER:NOWALL,10P,1R,2mm,ANGLE					
CN706	3711-001198	CONNECTOR-HEADER:NOWALL,10P,1R,2mm,ANGLE					
DT701	0703-001096	LED DISPLAY:AMB,6,10,50x22.5mm					
Q709	0501-000398	TR-SMALL SIGNAL:KSC945,NPN,250mW,TO-92,T					
Q710	0501-000398	TR-SMALL SIGNAL:KSC945,NPN,250mW,TO-92,T					
Q716	0501-000290	TR-SMALL SIGNAL:KSA643-Y,PNP,500mW,TO-92					
R709	2001-000290	R-CARBON:10KOHM,5%,1/8W,AA,TP,1.8X3.2MM					
R710	2001-000290	R-CARBON:10KOHM,5%,1/8W,AA,TP,1.8X3.2MM					
R717	2001-000969	R-CARBON:75OHM,5%,1/8W,AA,TP,1.8X3.2MM					
R725	2001-000969	R-CARBON:75OHM,5%,1/8W,AA,TP,1.8X3.2MM					
R726	2001-000969	R-CARBON:75OHM,5%,1/8W,AA,TP,1.8X3.2MM					
R731	2001-000290	R-CARBON:10KOHM,5%,1/8W,AA,TP,1.8X3.2MM					
RM701	AC59-60060A	MODULE-REMOCON:GP1U281R,SHARP,38KHZ,-,-,					
-	-	ASSY-PCB-F/TIMER:LED SINGLE	S.N.A.				
C701	2401-002165	C-AL:100uF,20%,16V,GP,TP,6.3x7,5					
C702	2202-000797	C-CERAMIC,MLC-AXIAL:10NF,30%,16V,Y5S,TP,					
C703	2202-000173	C-CERAMIC,MLC-AXIAL:1nF,10%,50V,Y5P,TP,1					
CN705	3711-001198	CONNECTOR-HEADER:NOWALL,10P,1R,2mm,ANGLE					
CN706	3711-001198	CONNECTOR-HEADER:NOWALL,10P,1R,2mm,ANGLE					
D711	0401-000101	DIODE-SWITCHING:1N4148,100V,200mA,DO-35,					
LD702	0601-001201	LED ROUND,RED,3mm,635nm					
LD703	0601-001408	LED:TAPG,-,-,-					
LD704	0601-001408	LED:TAPG,-,-,-					
LD705	0601-001408	LED:TAPG,-,-,-					
LD706	0601-001408	LED:TAPG,-,-,-					
LD707	0601-001408	LED:TAPG,-,-,-					
LD709	0601-001408	LED:TAPG,-,-,-					
Q710	0501-000398	TR-SMALL SIGNAL:KSC945,NPN,250mW,TO-92,T					
R710	2001-000290	R-CARBON:10KOHM,5%,1/8W,AA,TP,1.8X3.2MM					
R729	2001-000490	R-CARBON:200OHM,5%,1/8W,AA,TP,1.8X3.2MM					

MEMO

5. Schematic Diagrams

Block Identification of Main PCB	5-2
5-1 S.M.P.S. (Free Voltage ; SVR-433/233/230B/230W/131)	5-3
5-2 S.M.P.S. (230 Voltage ; SVR-2301)	5-4
5-3 Power Drive	5-5
5-4 System Control/Servo/Display/F-AV/Shuttle	5-6
5-5 Audio/Video/OSD	5-7
5-6 TM-Block/Input-Output	5-8
5-7 Remote-Control (Multi-TV)	5-9
5-8 Remote-Control (VCR Only)	5-10

Note

For schematic Diagram
 - Resistors are in ohms, 1/8W unless otherwise noted.

Special note :

Most semiconductor devices are electrostatically sensitive and therefore require the special handling techniques described under the "electrostatically sensitive (ES) devices" section of this service manual.

Note :

Do not use the part number shown on this drawing for ordering. The correct part number is shown in the parts list (may be slightly different or amended since this drawing was prepared).

Important safety notices :

Components identified with the mark ⚠ have the special characteristics for safety. When replacing any of these components. Use only the same type.

Block Identification of Main PCB

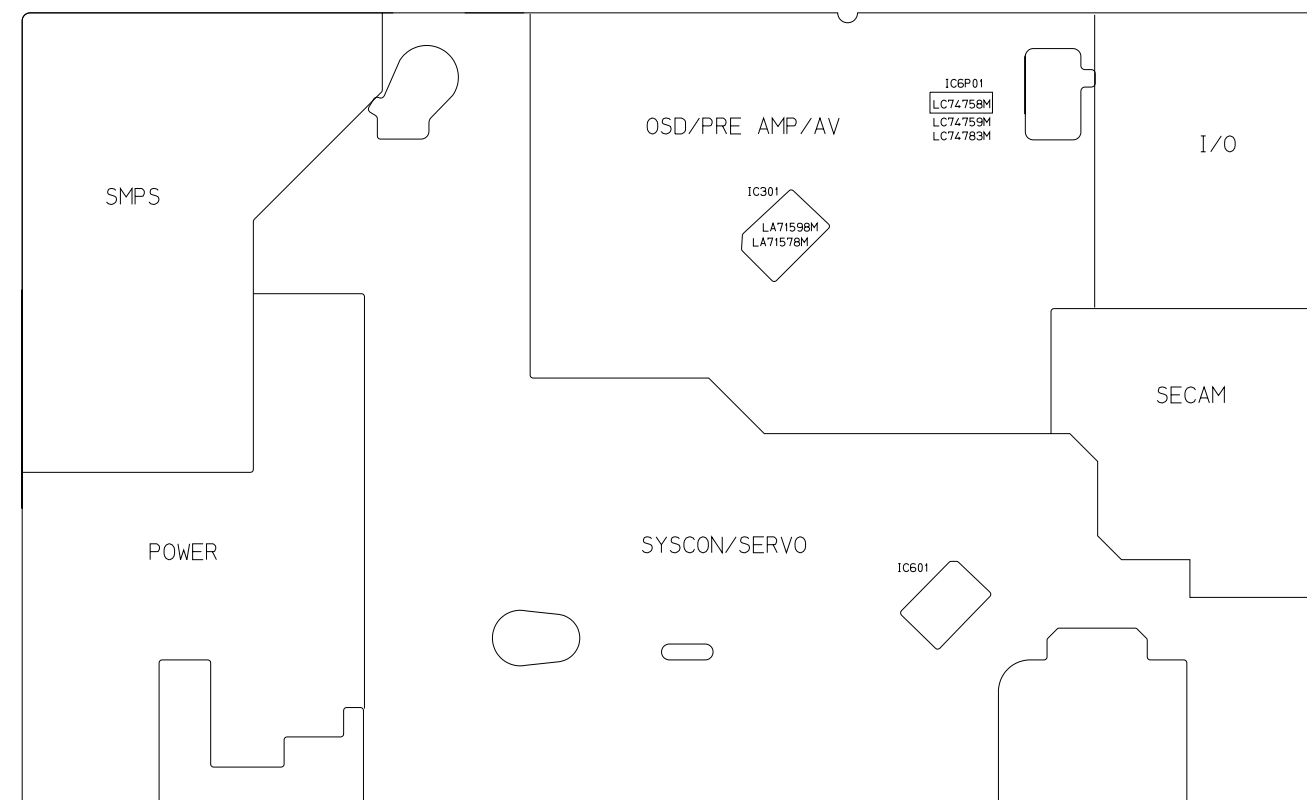
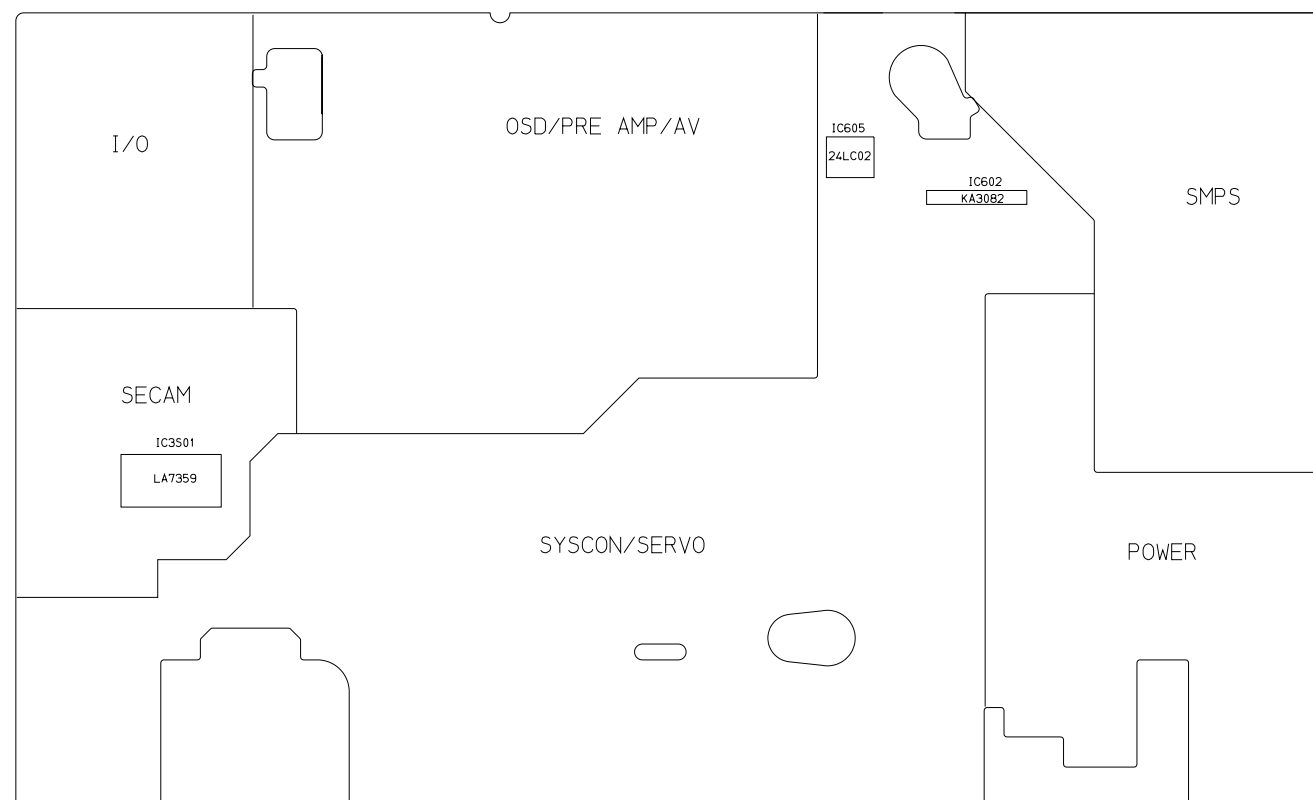

5-1 S.M.P.S. (Free Voltage ; SVR-433/233/230B/230W/131)

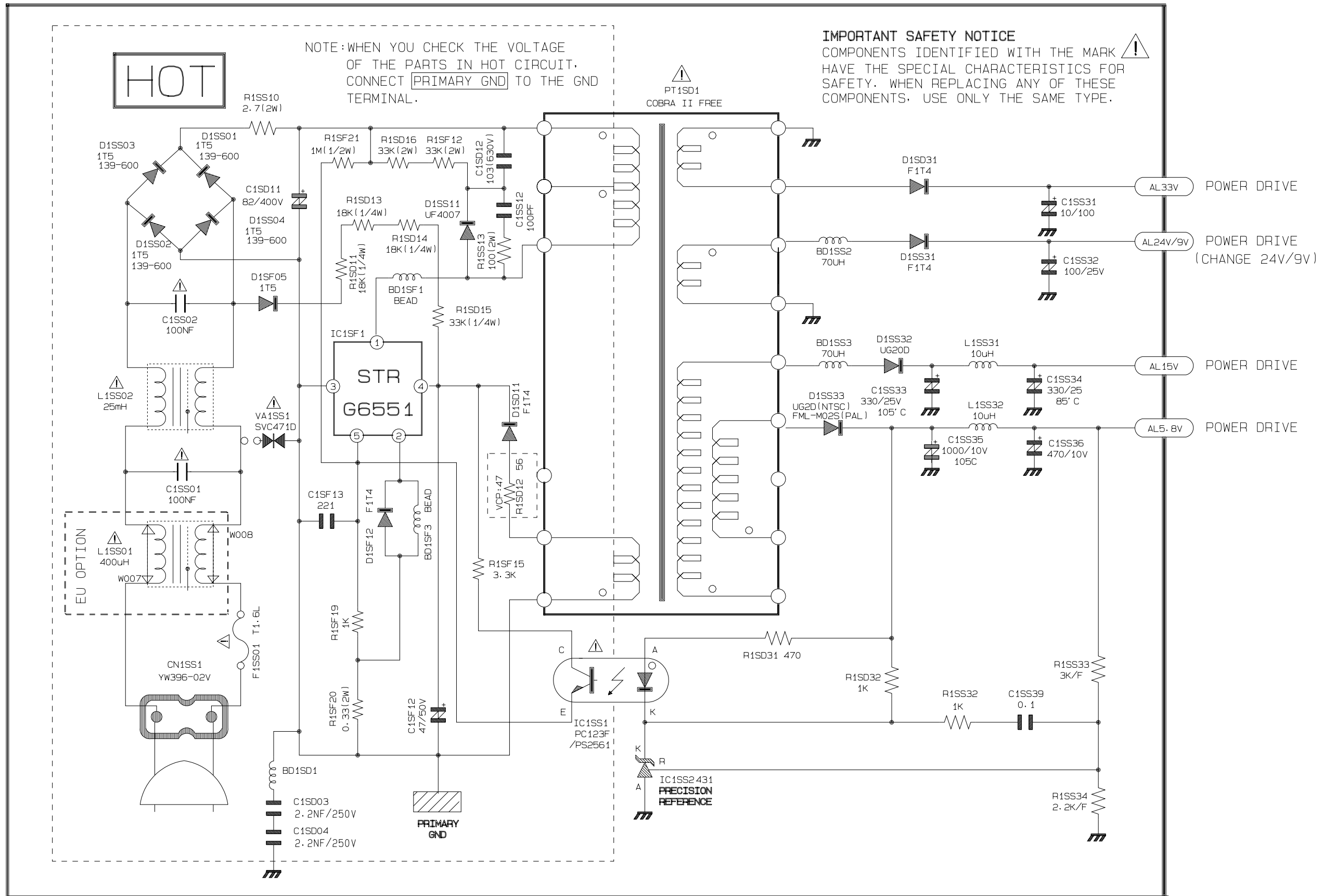

5-2 S.M.P.S. (230 Voltage ; SVR-2301)

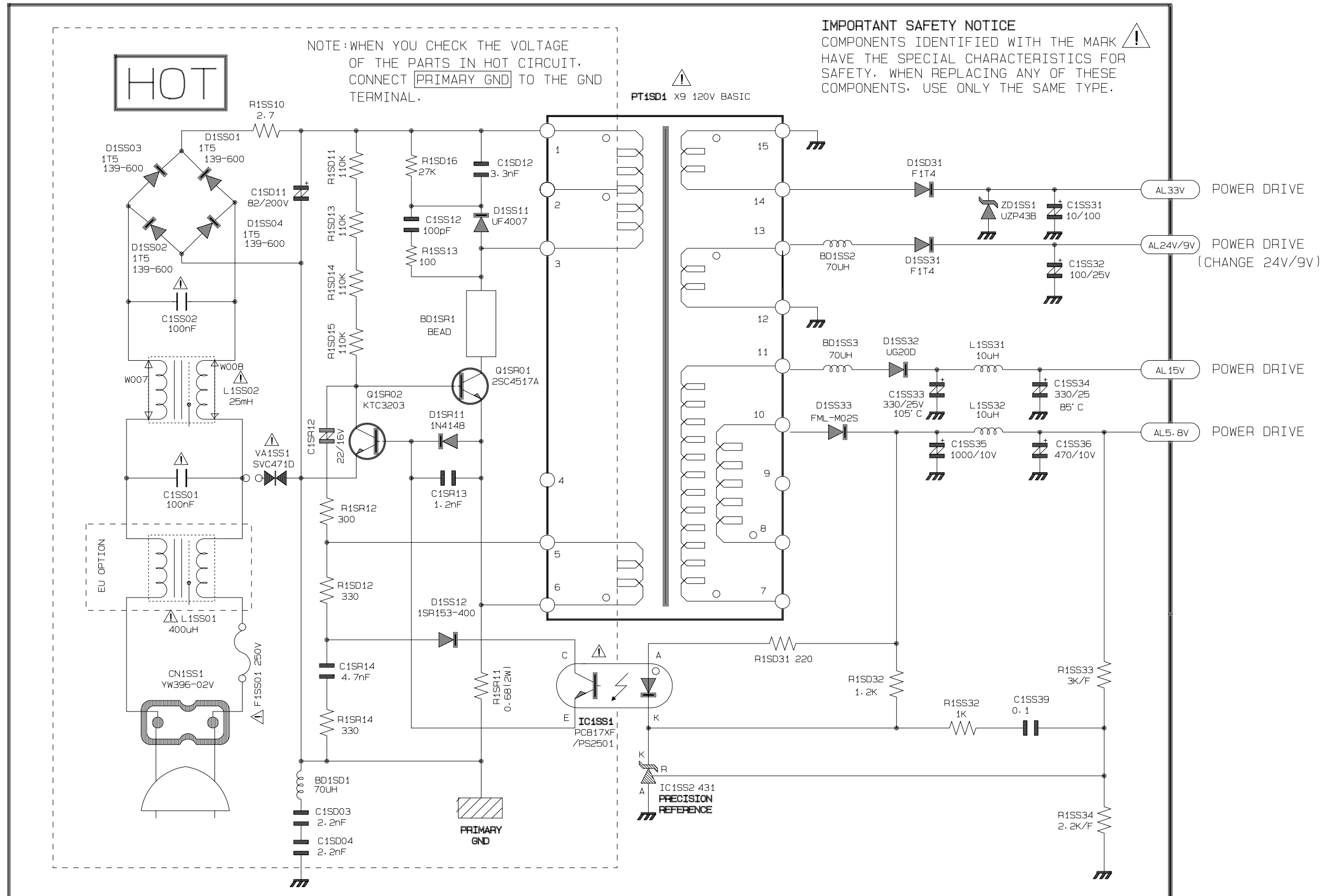

5-3 Power Drive

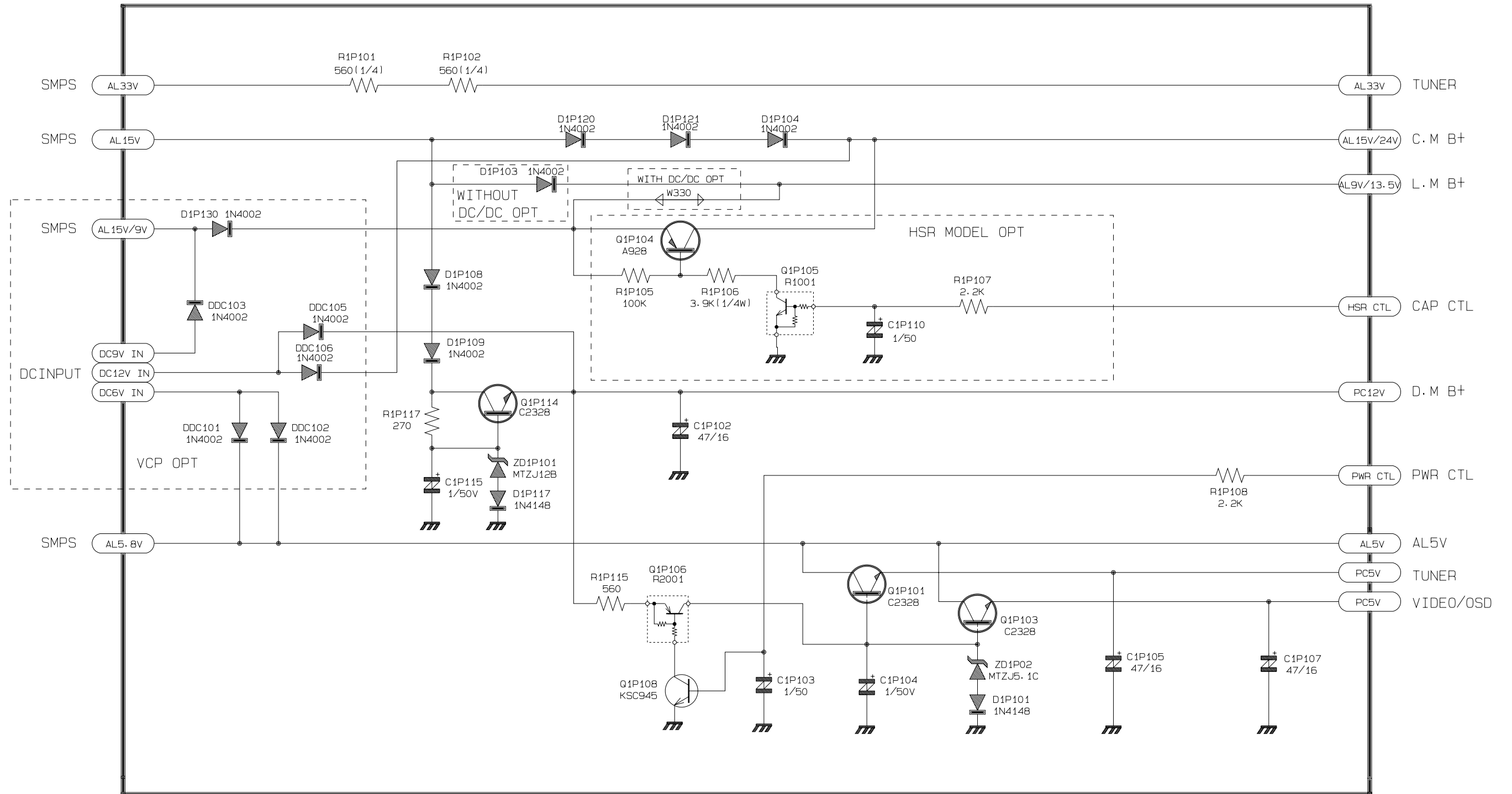

5-4 System Control/Servo/Display/F-AV/Shuttle

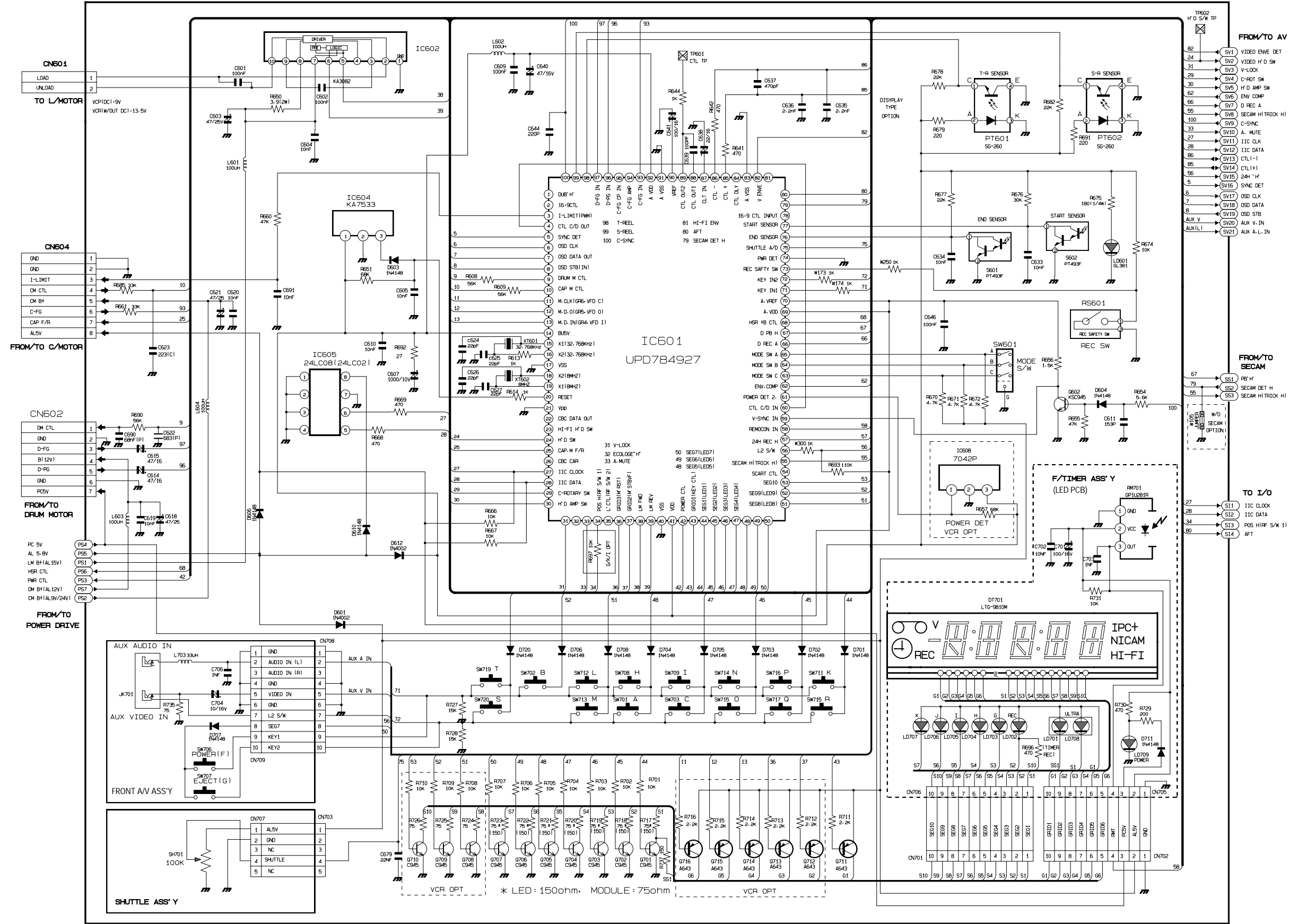

5-5 Audio/Video/OSD

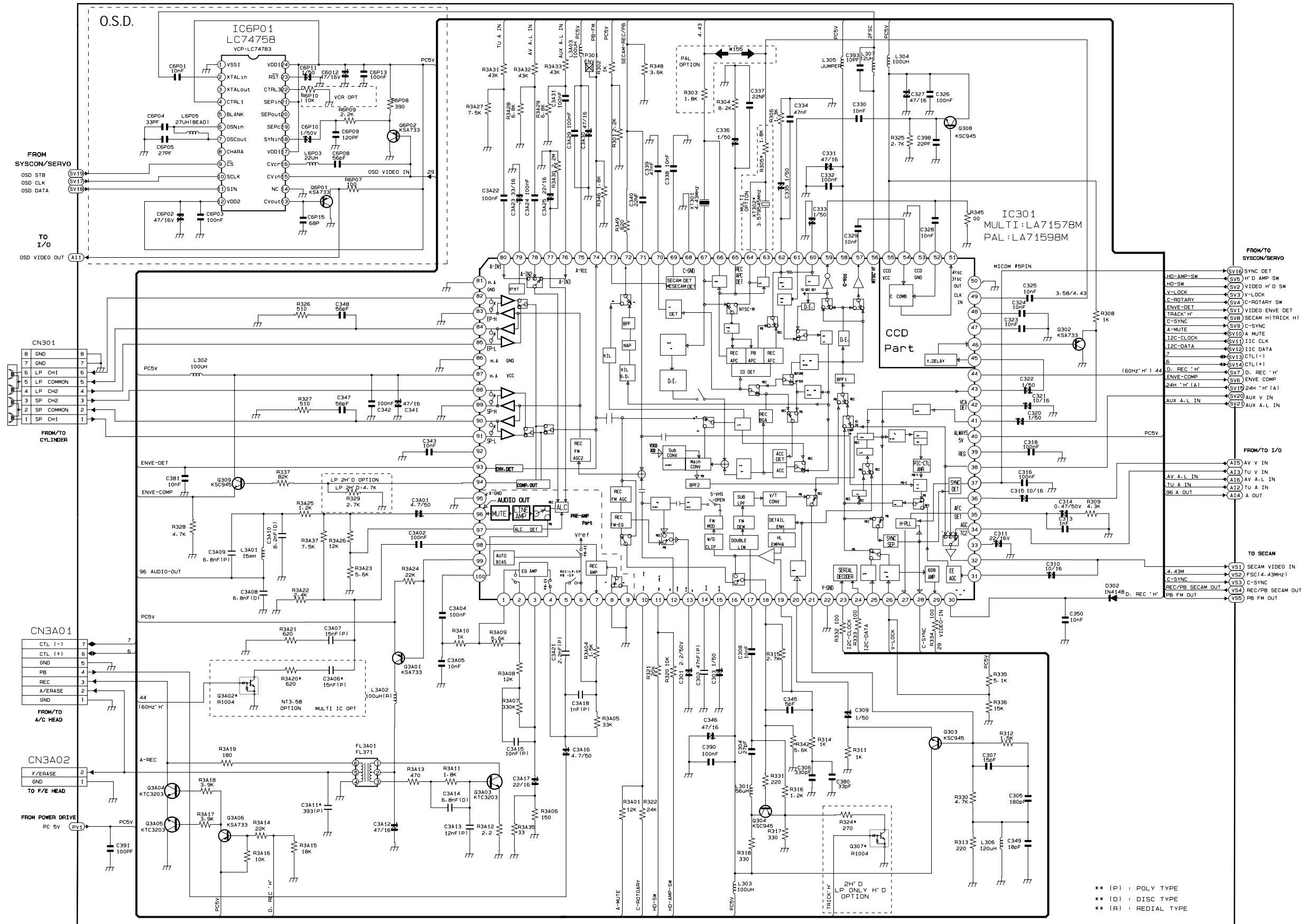

5-6 TM-Block/Input-Output

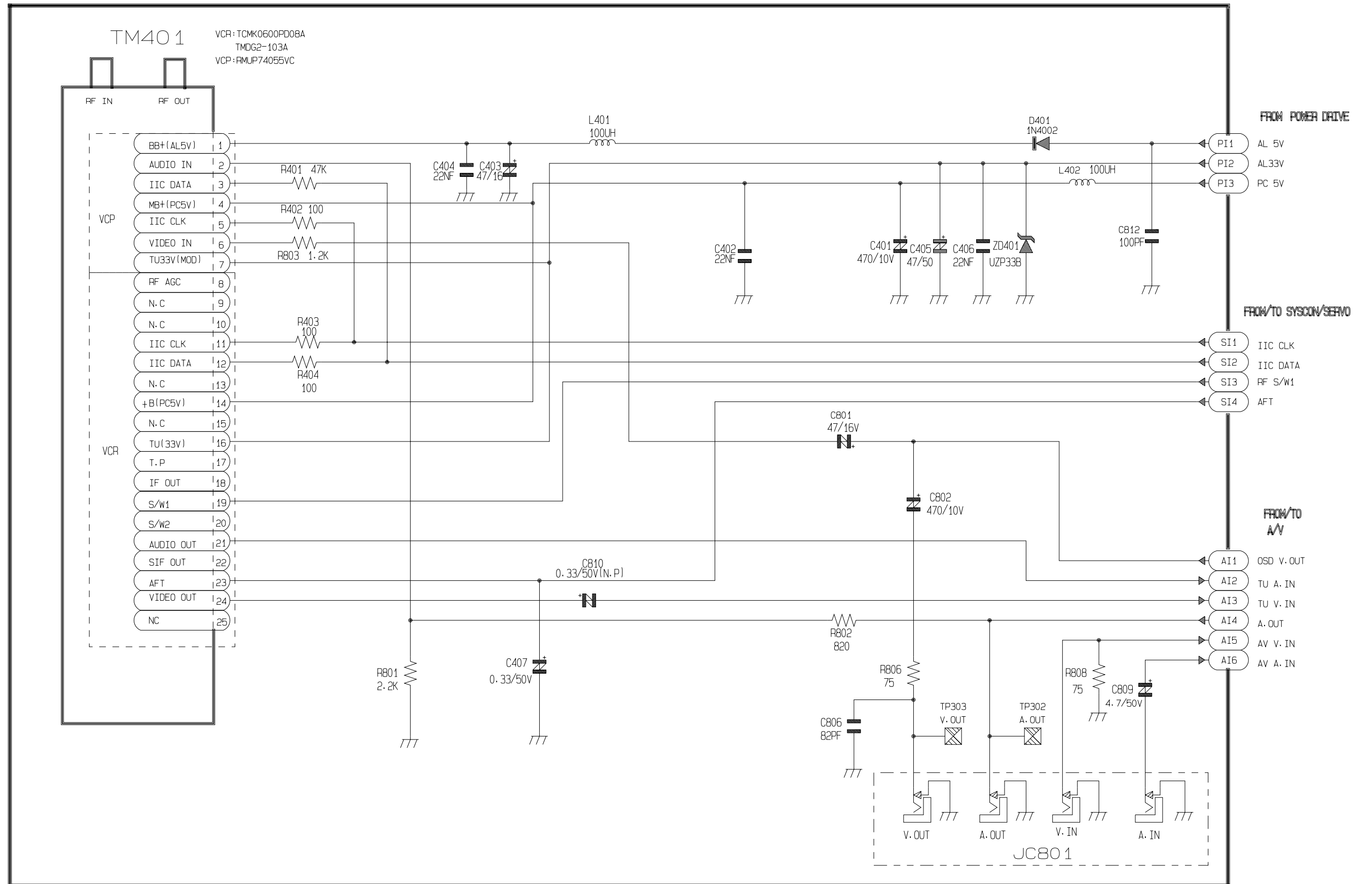

5-7 Remote-Control (Multi-TV)

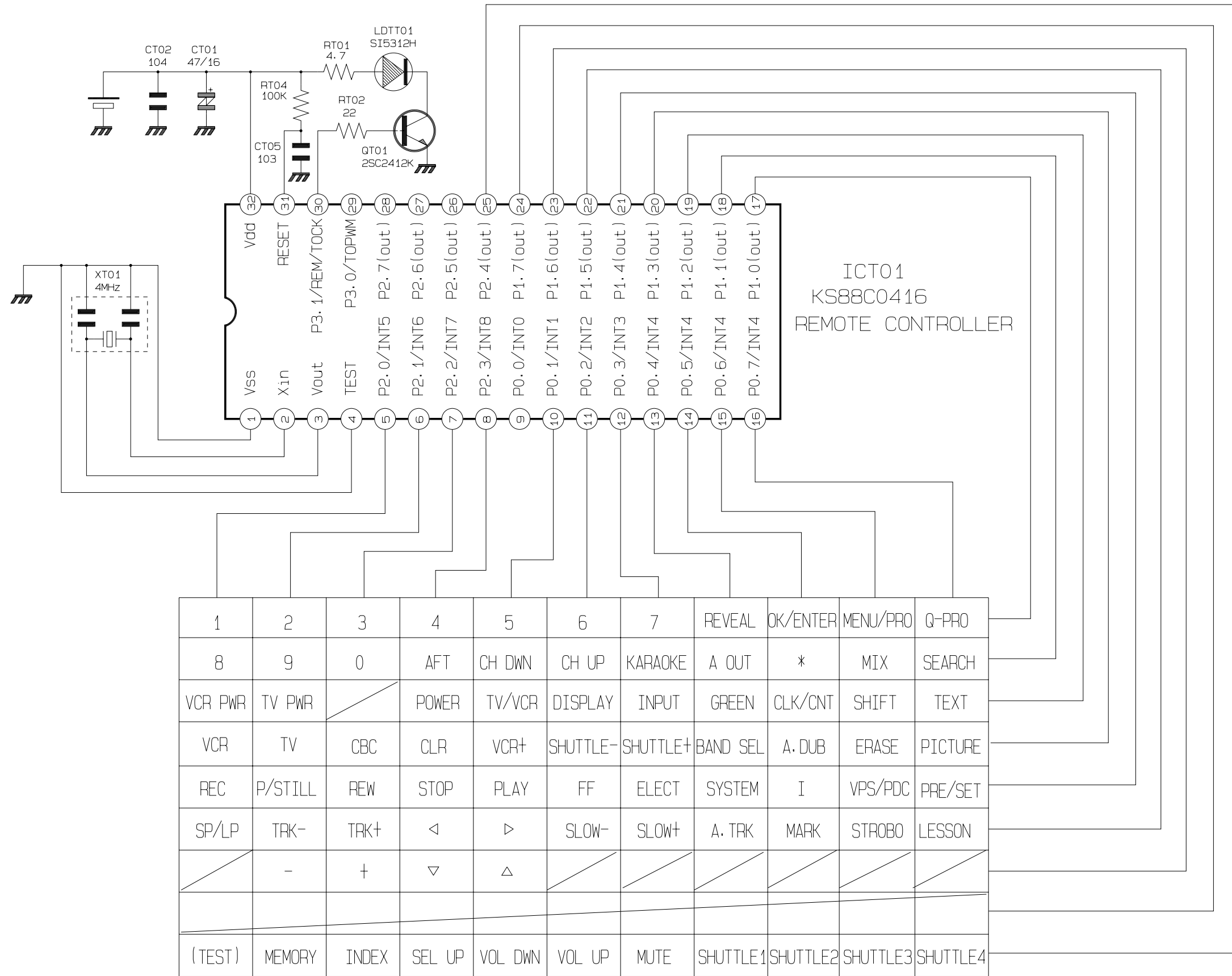

5-8 Remote-Control (VCR Only)

