



# VIDEO CASSETTE RECORDER

## SVR-527

SERVICE MANUAL

SVR-527

# **SERVICE** *Manual*

For mechanical disassembly and adjustment, refer to the "Mechanical Manual" (DX-9R → AC68-00001A).



### VIDEO CASSETTE RECORDER

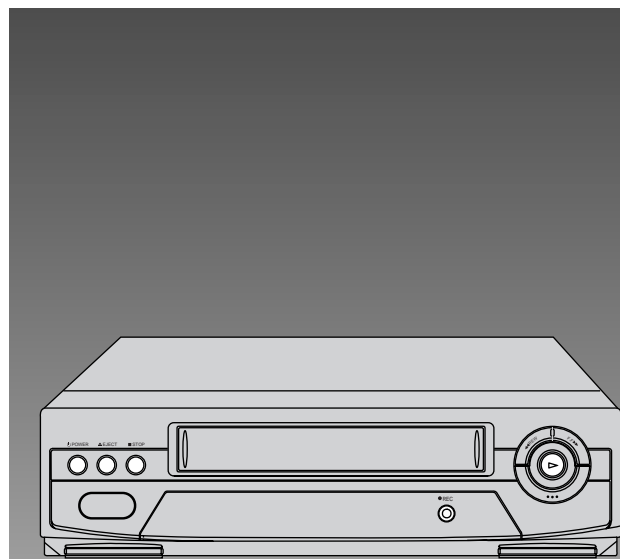

### CONTENTS

1. Precautions
2. Alignment and Adjustment
3. Exploded View and Parts List
4. Electrical Parts List
5. Schematic Diagrams

# IMPORTANT SERVICE GUIDE

## ◆ MODE SWITCH (PROGRAM SWITCH) ASSEMBLY POINT

1) When installing the ass'y full deck on the Main PCB, be sure to align the assembly point of mode switch.

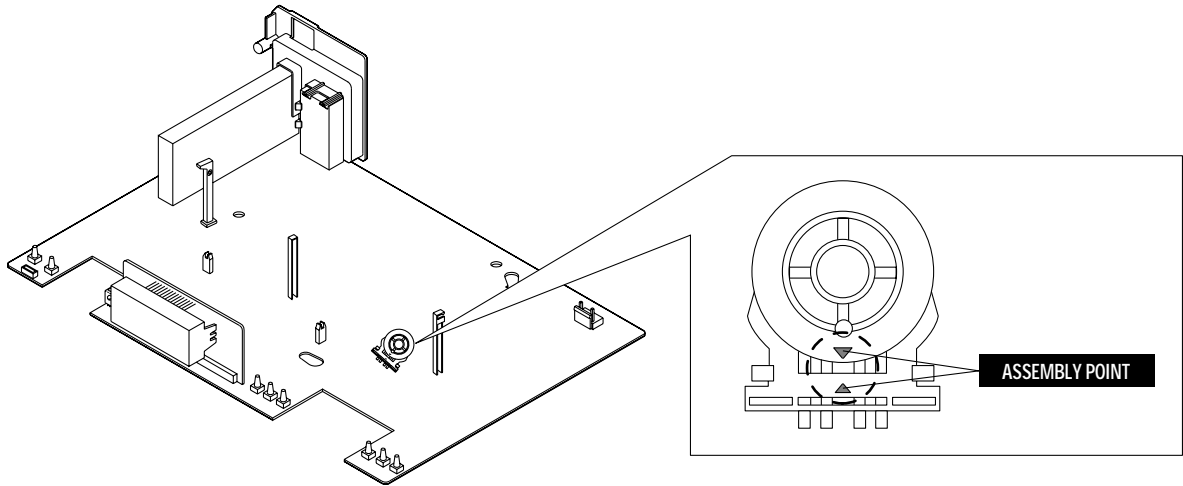

Fig. 1

## ◆ HOW TO EJECT THE CASSETTE TAPE

(If the unit does not operate on condition that tape is inserted into housing ass'y)

- 1) Remove the Holder Worm ❶ and the gear worm ❷. (See Fig. 2)
- 2) Turn the Gear Worm Wheel ❸ counterclockwise in the direction of arrow with screw driver. (See Fig. 2)
- 3) When Slider S, T are approached in the position of unloading, rotate holder Clutch counterclockwise after inserting screw driver in the hole of frame's bottom in order to wind the unwounded tape. (Refer to Fig. 3)  
(If you rotate Gear Worm Wheel continuously when tape is in state of unwinding, you may cause a tape contamination by grease and tape damage. Be sure to wind the unwounded tape in the state of set horizontally.)
- 4) Rotate Gear Worm Wheel ❸ counterclockwise using screw driver again up to the state of eject mode and then pick out the tape. (Refer to Fig. 2)

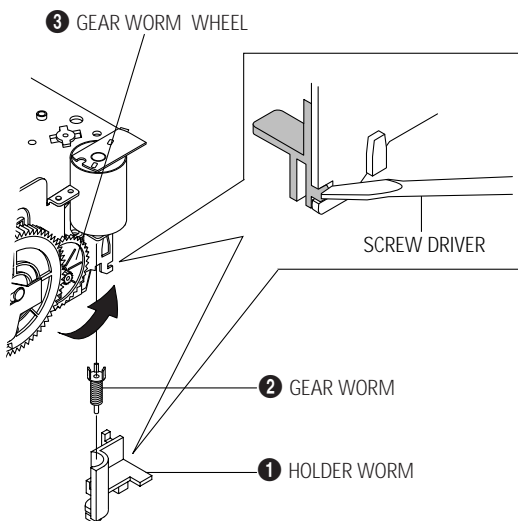

Fig. 2

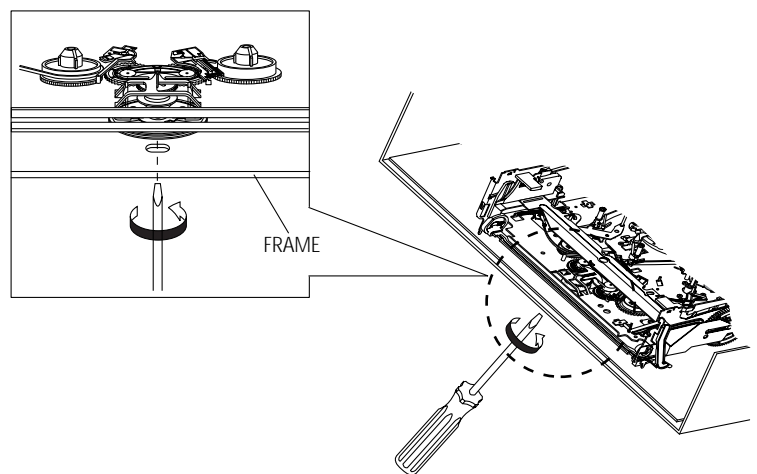

Fig. 3

# 1. Precautions

1. Be sure that all of the built-in protective devices are replaced. Restore any missing protective shields.
2. When reinstalling the chassis and its assemblies, be sure to restore all protective devices, including : control knobs and compartment covers.
3. Make sure that there are no cabinet openings through which people--particularly children --might insert fingers and contact dangerous voltages. Such openings include the spacing between the picture tube and the cabinet mask, excessively wide cabinet ventilation slots, and improperly fitted back covers.

If the measured resistance is less than 1.0 megohm or greater than 5.2 megohms, an abnormality exists that must be corrected before the unit is returned to the customer.

4. Leakage Current Hot Check (See Fig. 1-1) :  
Warning : Do not use an isolation transformer during this test. Use a leakage current tester or a metering system that complies with American National Standards Institute (ANSI C101.1, *Leakage Current for Appliances*), and Underwriters Laboratories (*UL Publication UL1410, 59.7*).

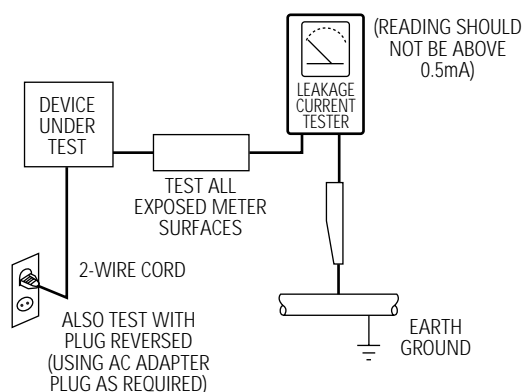



Fig. 1-1 AC Leakage Test

5. With the unit completely reassembled, plug the AC line cord directly the power outlet. With the unit's AC switch first in the ON position and then OFF, measure the current between a known earth ground (metal water pipe, conduit, etc.) and all exposed metal parts, including : antennas, handle brackets, metal cabinets, screwheads and control shafts. The current measured should not exceed 0.5 milliamp. Reverse the power-plug prongs in the AC outlet and repeat the test.
6. Antenna Cold Check :  
With the unit's AC plug disconnected from the AC source, connect an electrical jumper across the two AC prongs. Connect one lead of the ohmmeter to an AC prong.  
Connect the other lead to the coaxial connector.
7. Some semiconductor ("solid state") devices are easily damaged by static electricity. Such components are called Electrostatically Sensitive Devices (ESDs); examples include integrated circuits and some field-effect transistors. The following techniques will reduce the occurrence of component damage caused by static electricity.
8. Immediately before handling sny semiconductor components or assemblies, drain the electrostatic charge from your body by touching a known earth ground. Alternatively, wear a discharging Wrist-strap device. (Be sure to remove it prior to applying power--this is an electric shock precaution.)
9. Design Alteration Warning :  
Never alter or add to the mechanical or electrical design of this unit. Example : Do not add auxiliary audio or video connectors. Such alterations might create a safety hazard. Also, any design changes or additions will void the manufacturer's warranty.
10. Never defeat any of the B+ voltage interlocks. Do not apply AC power to the unit (or any of its assemblies) unless all solid-state heat sinks are correctly installed.

11. Always connect a test instrument's ground lead to the instrument chassis ground before connecting the positive lead; always remove the instrument's ground lead last.
12. Observe the original lead dress, especially near the following areas : Antenna wiring, sharp edges, and especially the AC and high voltage power supplies. Always inspect for pinched, out-of-place, or frayed wiring. Do not change the spacing between components and the printed circuit board. Check the AC power cord for damage. Make sure that leads and components do not touch thermally hot parts.
13. Product Safety Notice :  
Some electrical and mechanical parts have special safety-related characteristics which might not be obvious from visual inspection. These safety features and the protection they give might be lost if the replacement component differs from the original—even if the replacement is rated for higher voltage, wattage, etc.

Components that are critical for safety are indicated in the circuit diagram by shading, (  or  ).

Use replacement components that have the same ratings, especially for flame resistance and dielectric strength specifications. A replacement part that does not have the same safety characteristics as the original might create shock, fire or other hazards.

## 2. Alignment and Adjustment

### 2-1 Reference

- 1) X-Point (Tracking center) adjustment, "Head switching adjustment" can be adjusted with remote control.
- 2) When replacing the Micom (IC601) and NVRAM (IC603 ; EEPROM) be sure to adjust the "Head switching adjustment".
- 3) When replacing the cylinder ass'y, be sure to adjust the "X-Point" and "Head switching adjustment".
- 4) Among Samsung VCR remote control used for adjustment as a accessory, only the remote control that has figures buttons (0 ~ 9) is available for all adjustment regardless of chassis.
- 5) How to adjustment.
  - Press the "SW720 (TEST)" button on Main PCB to set the adjustment mode.
  - If the corresponding adjustment button is pressed, the adjustment is performed automatically.
  - If the adjustment is completed, be sure to turn the power off.

#### 2-1-1 Location of adjustment button of remote control

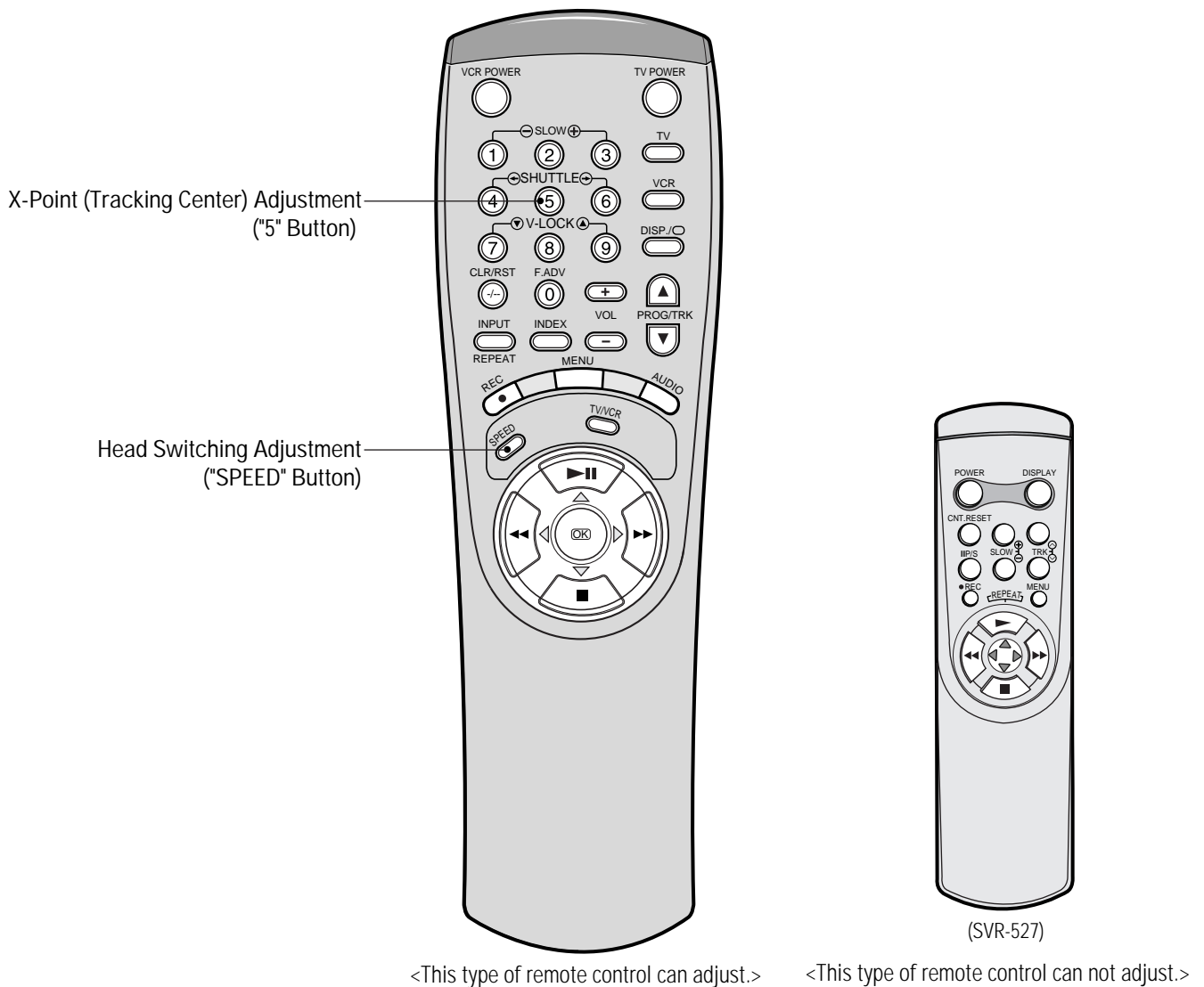

Fig. 2-1

### 2-1-2 SW720 (TEST) location for adjustment mode setting

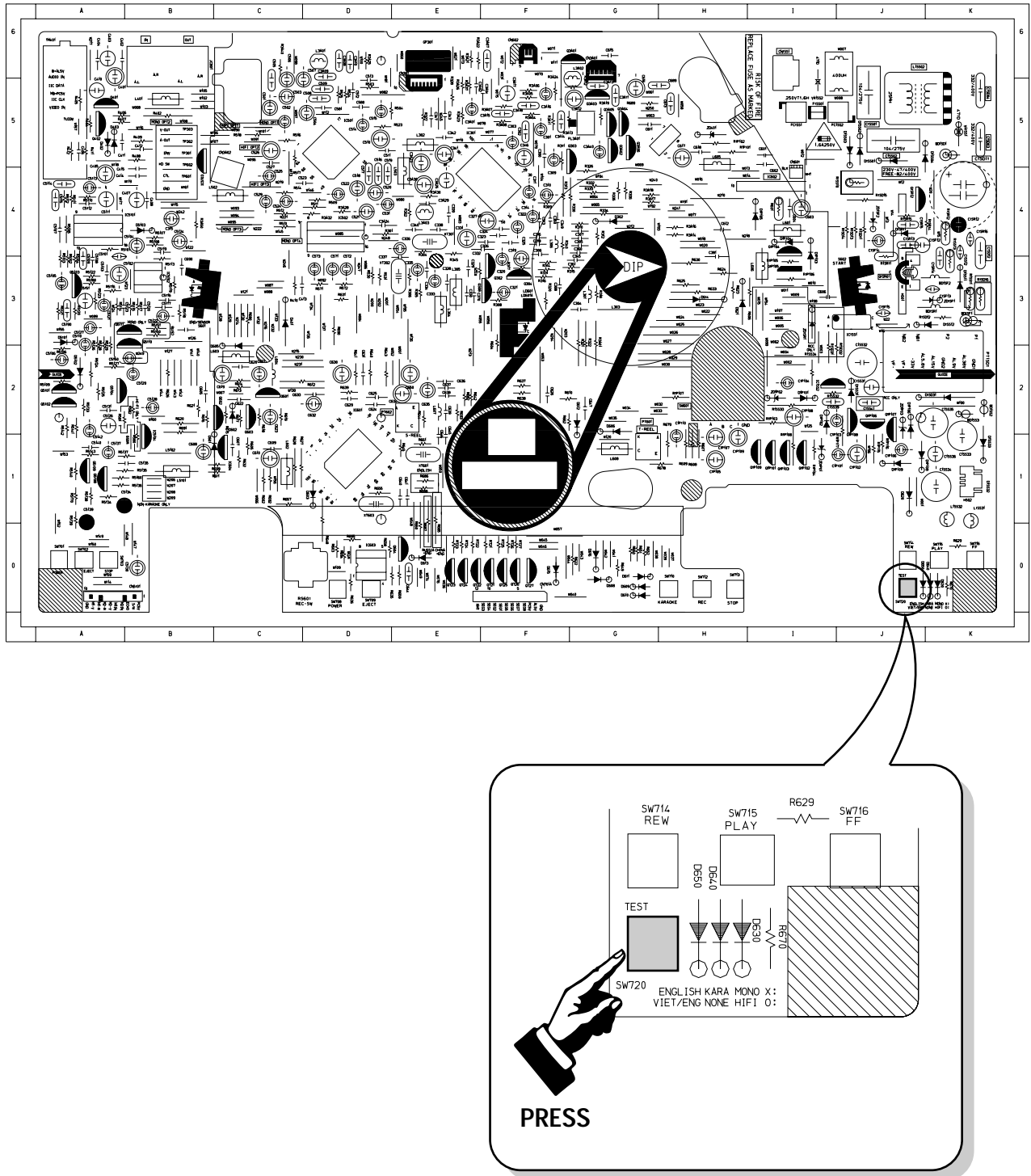

Fig. 2-2 Main PCB (Top View)

## 2-2 Mechanical Adjustment

**Note :** Refer to the Mechanical Manual “DX-9R (AC68-00001A)” for the adjustment and confirmation of ass’y full deck.

### 2-2-1 The number and position of test point

<b>Test point :</b>	TP601 (Control Pulse)	TP301 (Envelope)
	TP602 (H'D S/W -Trigger)	TP302 (Audio output)
		TP303 (Video output)

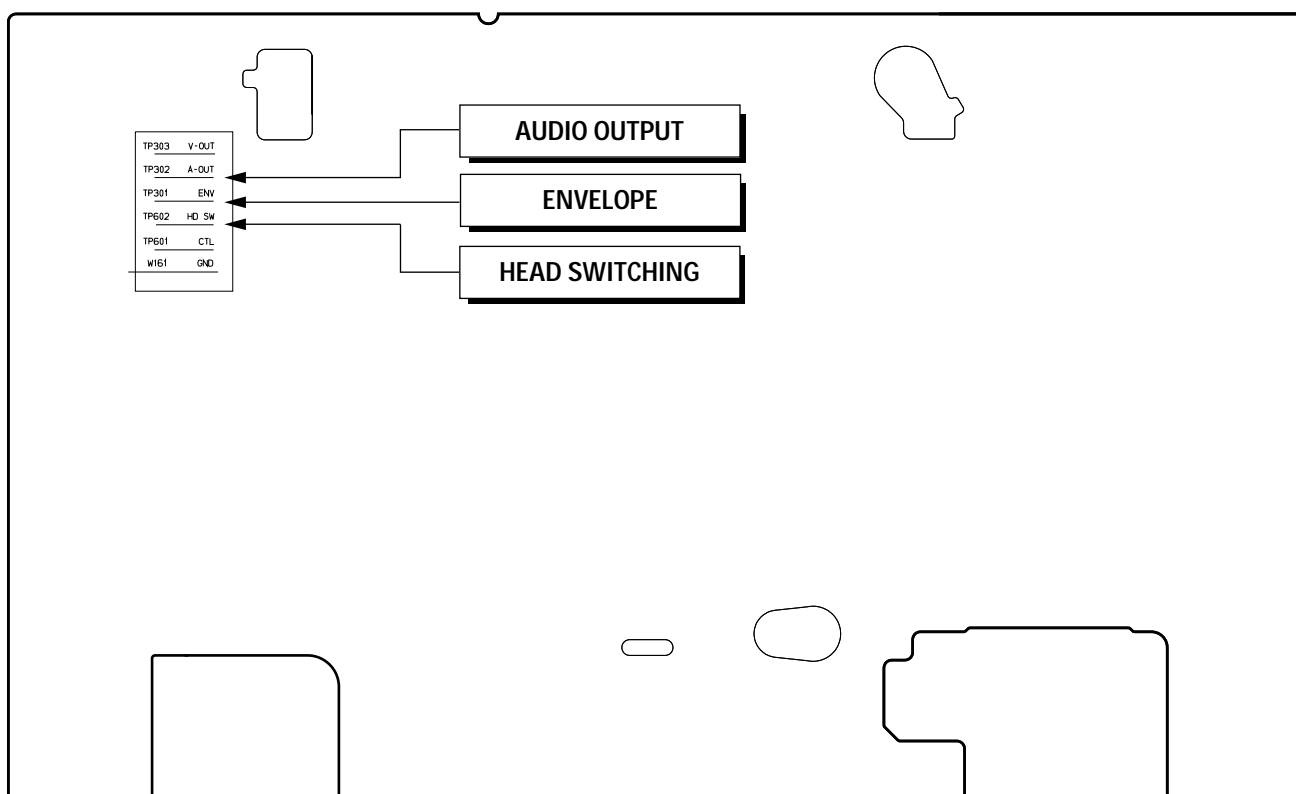

Fig. 2-3 Location of Test point (Main PCB-Top View)

#### 2-2-1 ACE Head Position (X-Point) Adjustment (See the 2-2-1(d) ACE Head Position (X-Point) Adjustment on page 2-2 of the Mechanical Manual)

- 1) Playback the alignment tape (Color bar).
- 2) Press the “SW720 (TEST)” button on Main PCB to set the adjustment mode. (See Fig. 2-2)
- 3) Press the “5” button of remote control then adjustment is operated automatically. (See Fig. 2-1)
- 4) Connect the CH-1 probe to TP301 (Envelope) the CH-2 probe to TP602 (H'D switching pulse) and then trigger to CH-1.
- 5) Insert the (-) driver into the X-Point adjustment hole and adjust it so that envelope waveform is maximum.
- 6) Turn the Power off.

### 2-3 Head Switching Point Adjustment

- 1) Playback the alignment tape.
- 2) Press the “SW720 (TEST)” button on Main PCB to set the adjustment mode. (See Fig. 2-2)
- 3) Press the “SPEED” button of remote control then adjustment is operated automatically. (See Fig. 2-1)
- 4) Turn the Power off.

# MEMO

---

## 3. Exploded View and Parts List

---

	Page
3-1 Cabinet Assembly - - - - -	3-2
3-2 Mechanical Parts (Top Side) - - - - -	3-4
3-3 Mechanical Parts (Bottom Side) - - - - -	3-6

### 3-1 Cabinet Assembly

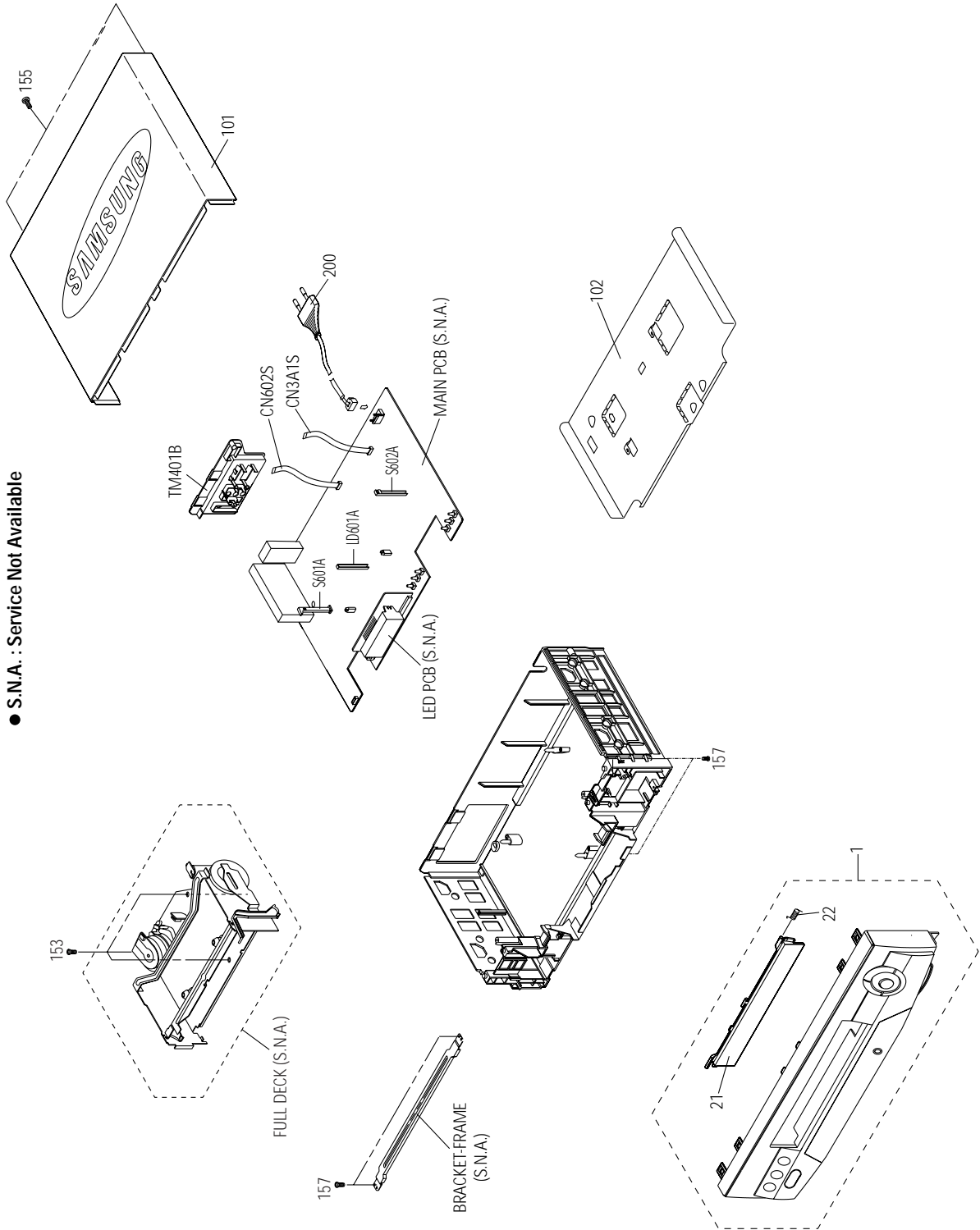

Loc. No	Parts No.	Description ; Specification	Remark
1	AC97-00033A	ASSY-PANEL FRONT;SVR-527,HIPS 94HB,BLK	
21	AC64-50995G	DOOR-CASSETTE;-ABS,-,T2.5,189*28,GRAY,-	
22	AC61-62032A	SPRING-MASK;X-9,-,SUS,-,4.4,-,SV-C130	
101	AC64-30892A	CABINET-TOP;X-9,SECC,PCM,0.5,360*208*41,	
102	AC63-30519A	COVER-BOTTOM;SV-C833,SPT,-,T0.3,-,-,X	
153	AC60-12126A	SCREW-BH;-BH,-,4*12,FE,FZY,-,-,-	
155	AC60-12134A	SCREW-TAP BH;-BH,-,2-4X16,-,FE	
157	AC60-10063A	SCREW-TAPTITE;BH,+,-,M3,L12,ZPC3,SWRCH18	
200	AC39-10019A	POWER CORD;KKP-419C,H03VVH2-F,VDE/KEMA-K	
CN3A1S	3809-001110	CABLE-FLAT;30V,80C,150mm,7P,1.25mm,UL289	
CN602S	3809-001112	CABLE-FLAT;30V,80C,130mm,5P,1.25mm,UL289	
LD601A	AC61-21009A	HOLDER-LED;-POM(M90-44),-BLK,-,X-9	
S601A	AC61-21008A	HOLDER-SENSOR;-POM(M90-44),-BLK,-,X-9	
S602A	AC61-21008A	HOLDER-SENSOR;-POM(M90-44),-BLK,-,X-9	
TM401B	AC61-11063B	CONNECTOR BOARD-ASSY;SV-C17DV,HIPS94,HB,	

### 3-2 Mechanical Parts (Top Side)

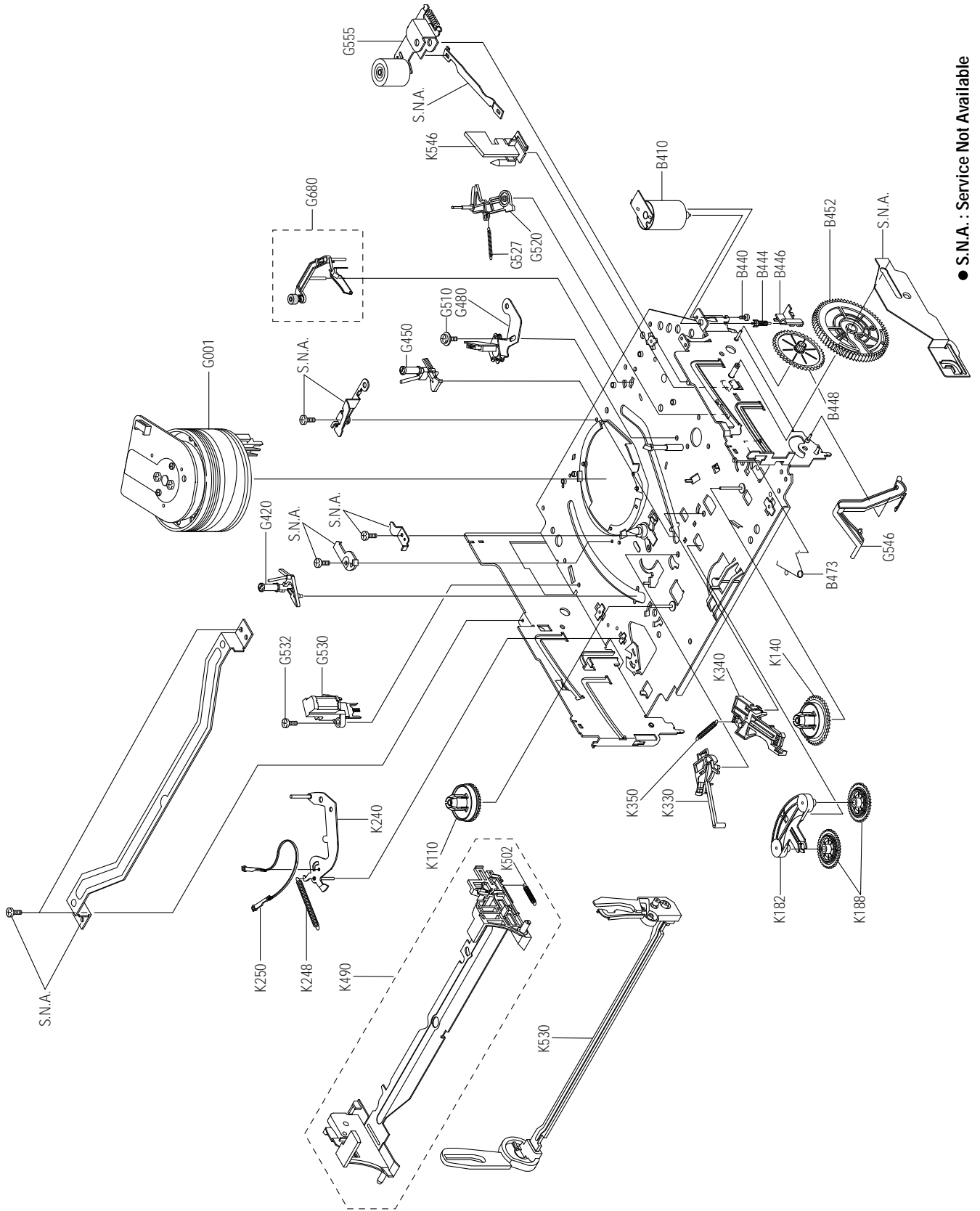

Loc. No	Parts No.	Description ; Specification	Remark
B410	AC31-12016A	MOTOR-LOADING ASSY;-,-,X-9	
B440	AC60-10515A	SCREW-MACHINE;-,-,PH,+,-,M3,L3,ZPC,-,YEL	
B444	AC66-20571A	GEAR-WORM;-,-,POM SW-01,0.5,2,-,4.5,X-9	
B446	AC61-21005A	HOLDER-WORM;-,-,POM M90-44,-,-,-,X-9	
B448	AC66-20573A	GEAR-WORM WHEEL;-,-,POM SW-01,0.6,11,-,6.6	
B452	AC66-20575A	GEAR-FL CAM;-,-,POM SW-01,M0.6,Z88,-,PCD58	
B473	AC61-60559A	SPRING-PINCH DRIVE;-,-,TS,SUS304,PI0.5,OD4	
G001	AC96-10482L	ASSY-CYLINDER;CX-9, PAL 2HD(SP)HI-FI	
G420	AC66-80142A	SLIDER-SUPPLY ASSY;-,-,X-9(TS),-,-,-,X-9	
G450	AC66-80141A	SLIDER-TAKE UP ASSY;-,-,X-9(TS),-,-,-,X-9	
G480	AC33-10217H	HEAD-ACE ASSY;-,-,-,-,X-9	
G510	AC60-10518A	SCREW-TAP TITE;-,-,PH,+,-,SW+ZW,M2.6,L5.6,ZP	
G520	AC66-30539A	LEVER-#9 GUIDE ASSY;-,-,X-9(TS),-,-,-,X-9	
G527	AC61-60553A	SPRING-#9 GUIDE;-,-,ES,SUS304-WPB,OD3.1,0.	
G530	AC33-10217G	HEAD-FE;VAA00000275,-,-,-,-,X-9	
G532	AC60-10519A	SCREW-TAP TITE;-,-,PH,+,-,M2.6,L8,ZPC	
G546	AC66-30535A	LEVER-FL DOOR;-,-,POM M90-44,-,-,BLK,X-9	
G555	AC59-90403A	UNIT-PINCH ASSY;X-9,-	
G680	AC66-30557A	LEVER-H/CLEANER ASSY;-,-,POM+URETHANE,-,-,-	(OPTIONAL)
K110	AC66-10267A	REEL-DISK S;-,-,POM M90-44,-,-,-,X-9	
K140	AC66-10268A	REEL-DISK T;-,-,POM M90-44,-,-,-,X-9	
K182	AC66-30524A	LEVER-IDLER;-,-,POM9044,-,-,-,-	
K188	AC66-20577A	GEAR-IDLER;-,-,PEBAX 7033,-,-,-,-,X-9	
K240	AC66-30538A	LEVER-TENSION ASSY;-,-,X-9(TS),-,-,-,X-9	
K248	AC61-60554A	SPRING-TENSION LEVER;-,-,ES,SUS304-WPB,OD3	
K250	AC63-12029A	BAND-BRAKE ASSY;-,-,X-9(TS),-,-,-,X-9	
K330	AC66-30550A	LEVER-S.BRAKE ASSY;-,-,POM+SUS,-,-,-,-,X-9	
K340	AC66-30549A	LEVER-T.BRAKE ASSY;-,-,POM+SUS,-,-,-,-,X-9	
K350	AC61-60564A	SPRING-BRAKE;-,-,TENSION,SWP-A,0.25,3,-,X-	
K490	AC61-21010B	HOLDER-CASS ASSY;-,-,SECC+POM+SUS,-,-,-,-,X-	
K502	AC61-60561A	SPRING-FL.LEVER-LR;-,-,ES,SUS304 WPB,PI2.7	
K530	AC66-30546A	LEVER-FL.ARM ASS'Y;-,-,SECC+POM+SUS,-,-,-,-	
K546	AC61-50658A	GUIDE-CASS. DOOR;-,-,POM M90-44,-,-,-,NTR,-,	

### 3-3 Mechanical Parts (Bottom Side)

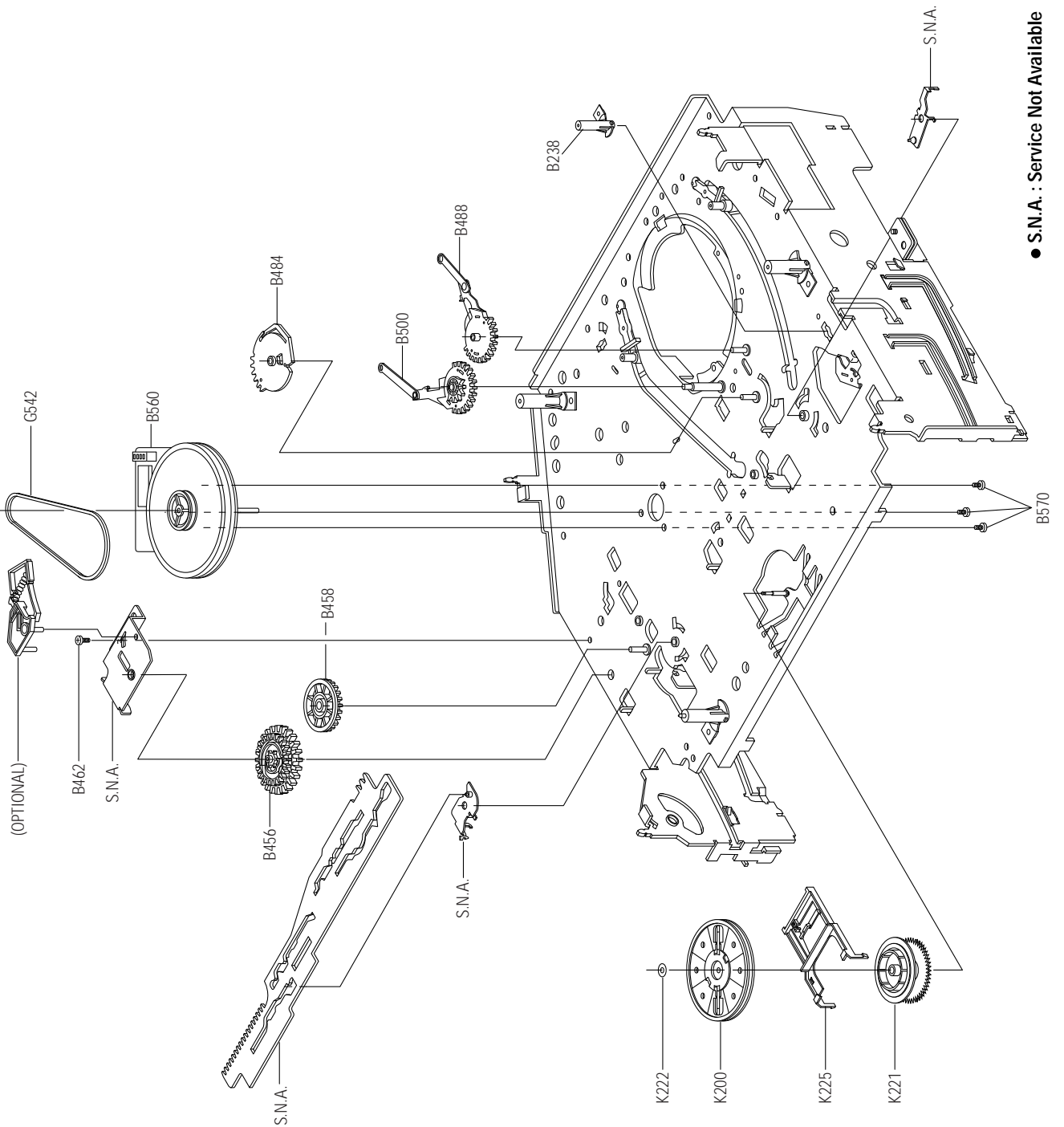

● S.N.A. : Service Not Available

Loc. No	Parts No.	Description ; Specification	Remark
B238	AC61-50660A	SLEEVE-TENSION;-;POM M90-44,-,-,ID3,-,-,	
B456	AC66-20576A	GEAR-JOINT 1;-;POM SW-01,M1.0,Z22,-,PCD2	
B458	AC66-20574A	GEAR-JOINT 2;-;POM SW-01,M1.0,Z14,-,PCD1	
B462	AC60-10517A	SCREW-TAP TITE;-;PH,+,-,M2.6,L5,ZPC,-,YE	
B484	AC66-20580A	GEAR-LOADING DRIVE;-;POM SW-01,M1.0,Z32,	
B488	AC66-30543A	LEVER-S LOAD ASSY;-,-,-,-,-,X-9	
B500	AC66-30542A	LEVER-T LOAD ASSY;-,-,-,-,-,X-9	
B560	AC31-12017A	MOTOR-CAPSTAN;DMVCMC07C,-,X-9	
B570	AC60-10514A	SCREW-CAPSTAN;-;PH,+,-,M2.6,L6,-	
G542	AC66-60051A	BELT-PULLEY;-;5CM-70,2 * 2,-,71.3,-,X-9	
K200	AC61-21012A	HOLDER-CLUTCH ASSY;-,-,-,-,-,X-9	
K221	AC66-20581A	GEAR-CENTER ASSY;-;POM,M=0.5,-,HIGHT T.,	
K222	AC60-30306A	WASHER-SLIT;-,-,ID2.1,OD5.0,T0.5,-,POLYS	
K225	AC66-30547A	LEVER-UP DOWN ASSY;-;POM+SUS,-,-,-,-,X-9	

# MEMO



Electrical Parts List

Loc.No	Part No	Description ; Specification	Remark	Loc.No	Part No	Description ; Specification	Remark
C618	2202-000797	C-CERAMIC,MLC-AXIAL:10NF,30%,16V,Y5S,TP,		Q602	0501-000398	TR-SMALL SIGNAL:K5C945,NPN,250mW,TO-92,T	
C619	2401-003107	C-AL:47uF,20%,16V,GP,TP,5x7,5		Q603	0501-000398	TR-SMALL SIGNAL:K5C945,NPN,250mW,TO-92,T	
C620	2202-002037	C-CERAMIC,MLC-AXIAL:100nF,80-20%,50V,Y5V		Q604	0501-000398	TR-SMALL SIGNAL:K5C945,NPN,250mW,TO-92,T	
C621	2401-000414	C-AL:10uF,20%,16V,GP,TP,4x7,5		R601	2003-000259	R-METAL OXIDE:3.90HM,5%,2W,AE,TP,6X16MM	
C622	2202-000145	C-CERAMIC,MLC-AXIAL:12NF,10%,50V,Y5P,TP		R602	2001-000281	R-CARBON:100OHM,5%,1/8W,AA,TP,1.8X3.2MM	
C623	2401-002299	C-AL:4.7uF,20%,50V,GP,TP,5x7,5		R603	2001-000281	R-CARBON:100OHM,5%,1/8W,AA,TP,1.8X3.2MM	
C624	2202-002037	C-CERAMIC,MLC-AXIAL:100nF,80-20%,50V,Y5V		R604	2001-000362	R-CARBON:150OHM,5%,1/8W,AA,TP,1.8X3.2MM	
C625	2202-002037	C-CERAMIC,MLC-AXIAL:100nF,80-20%,50V,Y5V		R605	2001-000522	R-CARBON:22KOHM,5%,1/8W,AA,TP,1.8X3.2MM	
C626	2202-000263	C-CERAMIC,MLC-AXIAL:470pF,10%,50V,Y5P,TP		R606	2001-000633	R-CARBON:30KOHM,5%,1/8W,AA,TP,1.8X3.2MM	
C629	2202-000830	C-CERAMIC,MLC-AXIAL:82pF,10%,50V,Y5P,TP,		R607	2001-000734	R-CARBON:4.7KOHM,5%,1/8W,AA,TP,1.8X3.2MM	
C630	2401-002069	C-AL:33uF,20%,16V,GP,TP,6.3x5,5		R608	2001-000734	R-CARBON:4.7KOHM,5%,1/8W,AA,TP,1.8X3.2MM	
C631	2202-000830	C-CERAMIC,MLC-AXIAL:82pF,10%,50V,Y5P,TP,		R609	2001-000734	R-CARBON:4.7KOHM,5%,1/8W,AA,TP,1.8X3.2MM	
C632	2401-000918	C-AL:22uF,20%,16V,GP,-,6.3x7,5		R610	2001-000429	R-CARBON:1KOHM,5%,1/8W,AA,TP,1.8X3.2MM	
C633	2202-000807	C-CERAMIC,MLC-AXIAL:22nF,+80-20%,25V,Y5V		R611	2001-000010	R-CARBON:68KOHM,5%,1/8W,AA,TP,1.8X3.2MM	
C634	2401-001507	C-AL:47uF,20%,16V,GP,TP,6.3x5,5		R612	2001-000281	R-CARBON:100OHM,5%,1/8W,AA,TP,1.8X3.2MM	
C635	2401-001775	C-AL:470nF,20%,50V,GP,TP,4x7,5		R613	2001-000780	R-CARBON:470OHM,5%,1/8W,AA,TP,1.8X3.2MM	
C636	2202-000797	C-CERAMIC,MLC-AXIAL:10NF,30%,16V,Y5S,TP,		R614	2001-000864	R-CARBON:56KOHM,5%,1/8W,AA,TP,1.8X3.2MM	
C637	2202-000121	C-CERAMIC,MLC-AXIAL:100pF,10%,50V,Y5P,TP		R615	2001-000435	R-CARBON:1MOHM,5%,1/8W,AA,TP,1.8X3.2MM	
C638	2202-000216	C-CERAMIC,MLC-AXIAL:027NF,5%,50V,SL,TP,		R616	2001-000429	R-CARBON:1KOHM,5%,1/8W,AA,TP,1.8X3.2MM	
C639	2202-000216	C-CERAMIC,MLC-AXIAL:027NF,5%,50V,SL,TP,		R617	2001-000429	R-CARBON:1KOHM,5%,1/8W,AA,TP,1.8X3.2MM	
C640	2202-000162	C-CERAMIC,MLC-AXIAL:015NF,5%,50V,SL,TP,		R618	2001-000281	R-CARBON:100OHM,5%,1/8W,AA,TP,1.8X3.2MM	
C641	2202-000162	C-CERAMIC,MLC-AXIAL:015NF,5%,50V,SL,TP,		R619	2001-000773	R-CARBON:470KOHM,5%,1/8W,AA,TP,1.8X3.2MM	
C644	2301-000392	C-FILM,PEF:15nF,5%,50V,TP,6.5x8.5x3.2mm,		R620	2001-000290	R-CARBON:10KOHM,5%,1/8W,AA,TP,1.8X3.2MM	
C645	2202-000205	C-CERAMIC,MLC-AXIAL:22pF,5%,50V,SL,TP,1.		R621	2001-000786	R-CARBON:47KOHM,5%,1/8W,AA,TP,1.8X3.2MM	
C646	2202-000205	C-CERAMIC,MLC-AXIAL:22pF,5%,50V,SL,TP,1.		R622	2001-000786	R-CARBON:47KOHM,5%,1/8W,AA,TP,1.8X3.2MM	
C647	2202-000162	C-CERAMIC,MLC-AXIAL:015NF,5%,50V,SL,TP,		R623	2001-000802	R-CARBON:5.6Kohm,5%,1/8W,AA,TP,1.8x3.2m	
C650	2401-001507	C-AL:47uF,20%,16V,GP,TP,6.3x5,5		R624	2001-000429	R-CARBON:1KOHM,5%,1/8W,AA,TP,1.8X3.2MM	
C689	2301-000471	C-FILM,PEF:68nF,5%,50V,TP,9x12x4.5mm,5mm		R625	2001-000864	R-CARBON:56KOHM,5%,1/8W,AA,TP,1.8X3.2MM	
C690	2202-000797	C-CERAMIC,MLC-AXIAL:10NF,30%,16V,Y5S,TP,		R626	2001-000429	R-CARBON:1KOHM,5%,1/8W,AA,TP,1.8X3.2MM	
CN601	AC39-20817S	LEAD CONNECTOR-ASSY:DP,SMH200-02,YBH200-		R627	2001-000429	R-CARBON:1KOHM,5%,1/8W,AA,TP,1.8X3.2MM	
CN602	3708-001163	CONNECTOR-FPC/FC/PIC-5P,1.25mm,STRAIGHT,		R628	2001-000429	R-CARBON:1KOHM,5%,1/8W,AA,TP,1.8X3.2MM	
CN604	3711-003749	CONNECTOR-HEADER-BOX,8P,2R,2mm,STRAIGHT,		R629	2001-000429	R-CARBON:1KOHM,5%,1/8W,AA,TP,1.8X3.2MM	
D601	0401-000101	DIODE-SWITCHING:1N4148,100V,200mA,DO-35,		R630	2001-000429	R-CARBON:1KOHM,5%,1/8W,AA,TP,1.8X3.2MM	
D602	0401-000101	DIODE-SWITCHING:1N4148,100V,200mA,DO-35,		R631	2001-000429	R-CARBON:1KOHM,5%,1/8W,AA,TP,1.8X3.2MM	
D603	0401-000101	DIODE-SWITCHING:1N4148,100V,200mA,DO-35,		R632	2001-000429	R-CARBON:1KOHM,5%,1/8W,AA,TP,1.8X3.2MM	
D605	0402-000127	DIODE-RECTIFIER:1N4002,100V,1A,DO-41,TP		R633	2001-000864	R-CARBON:56KOHM,5%,1/8W,AA,TP,1.8X3.2MM	
D606	0402-000127	DIODE-RECTIFIER:1N4002,100V,1A,DO-41,TP		R635	2001-000290	R-CARBON:10KOHM,5%,1/8W,AA,TP,1.8X3.2MM	
D608	0401-000101	DIODE-SWITCHING:1N4148,100V,200mA,DO-35,		R636	2001-000290	R-CARBON:10KOHM,5%,1/8W,AA,TP,1.8X3.2MM	
D609	0401-000101	DIODE-SWITCHING:1N4148,100V,200mA,DO-35,		R637	2001-000761	R-CARBON:430OHM,5%,1/8W,AA,TP,1.8X3.2MM	
D610	0401-000101	DIODE-SWITCHING:1N4148,100V,200mA,DO-35,		R638	2001-000761	R-CARBON:430OHM,5%,1/8W,AA,TP,1.8X3.2MM	
D611	0401-000101	DIODE-SWITCHING:1N4148,100V,200mA,DO-35,		R639	2001-000290	R-CARBON:1KOHM,5%,1/8W,AA,TP,1.8X3.2MM	
D612	0401-000101	DIODE-SWITCHING:1N4148,100V,200mA,DO-35,		R640	2001-000429	R-CARBON:1KOHM,5%,1/8W,AA,TP,1.8X3.2MM	
D613	0401-000101	DIODE-SWITCHING:1N4148,100V,200mA,DO-35,		R641	2001-000435	R-CARBON:1MOHM,5%,1/8W,AA,TP,1.8X3.2MM	
D614	0401-000101	DIODE-SWITCHING:1N4148,100V,200mA,DO-35,		R642	2001-000802	R-CARBON:5.6Kohm,5%,1/8W,AA,TP,1.8x3.2m	
D615	0402-000127	DIODE-RECTIFIER:1N4002,100V,1A,DO-41,TP		R643	2001-000290	R-CARBON:10KOHM,5%,1/8W,AA,TP,1.8X3.2MM	
D616	0401-000101	DIODE-SWITCHING:1N4148,100V,200mA,DO-35,		R644	2001-000258	R-CARBON:1.8KOHM,5%,1/8W,AA,TP,1.8X3.2MM	
D620	0402-000127	DIODE-RECTIFIER:1N4002,100V,1A,DO-41,TP		R645	2001-000429	R-CARBON:1KOHM,5%,1/8W,AA,TP,1.8X3.2MM	
D621	0401-000101	DIODE-SWITCHING:1N4148,100V,200mA,DO-35,		R648	2001-000429	R-CARBON:1KOHM,5%,1/8W,AA,TP,1.8X3.2MM	
D630	0401-000101	DIODE-SWITCHING:1N4148,100V,200mA,DO-35,		R649	2001-000429	R-CARBON:1KOHM,5%,1/8W,AA,TP,1.8X3.2MM	
D640	0401-000101	DIODE-SWITCHING:1N4148,100V,200mA,DO-35,		R650	2001-000429	R-CARBON:1KOHM,5%,1/8W,AA,TP,1.8X3.2MM	
IC601	AC09-00011A	IC-MCU:HD643977R,100P,-,SVK-C17DV,16BIT		R651	2001-000429	R-CARBON:1KOHM,5%,1/8W,AA,TP,1.8X3.2MM	
IC602	1003-001162	IC-MOTOR DRIVER:KA3082,SIP,10PIN,25MIL,D		R652	2001-000429	R-CARBON:1KOHM,5%,1/8W,AA,TP,1.8X3.2MM	
IC603	1103-000190	IC-EEPROM:24C02,256x8BIT,DIP,8P,300MIL,1		R655	2001-000435	R-CARBON:1MOHM,5%,1/8W,AA,TP,1.8X3.2MM	
IC604	AC14-12006C	IC:KA7533,DIP,-		R657	2001-000290	R-CARBON:10KOHM,5%,1/8W,AA,TP,1.8X3.2MM	
L601	AC27-92001B	COIL-PEAKING AXIAL:BAL04ST101K,-,-,-,-		R658	2001-000241	R-CARBON:1.5KOHM,5%,1/8W,AA,TP,1.8X3.2MM	
L602	AC27-92001B	COIL-PEAKING AXIAL:BAL04ST101K,-,-,-,-		R659	2001-000786	R-CARBON:47KOHM,5%,1/8W,AA,TP,1.8X3.2MM	
L603	AC27-92001B	COIL-PEAKING AXIAL:BAL04ST101K,-,-,-,-		R660	2001-000802	R-CARBON:5.6Kohm,5%,1/8W,AA,TP,1.8x3.2m	
L604	2701-000117	INDUCTOR-AXIAL:10uH,5%,2.4x3.4mm		R661	2001-000435	R-CARBON:1MOHM,5%,1/8W,AA,TP,1.8X3.2MM	
L605	AC27-92001B	COIL-PEAKING AXIAL:BAL04ST101K,-,-,-,-		R662	2001-000802	R-CARBON:5.6Kohm,5%,1/8W,AA,TP,1.8x3.2m	
L606	AC27-92001B	COIL-PEAKING AXIAL:BAL04ST101K,-,-,-,-		R670	2001-000290	R-CARBON:10KOHM,5%,1/8W,AA,TP,1.8X3.2MM	
L607	2701-000131	INDUCTOR-AXIAL:15uH,5%,2.4x3.4mm		R678	2001-000522	R-CARBON:22KOHM,5%,1/8W,AA,TP,1.8X3.2MM	
L608	AC27-92001B	COIL-PEAKING AXIAL:BAL04ST101K,-,-,-,-		R679	2001-000515	R-CARBON:220OHM,5%,1/8W,AA,TP,1.8X3.2MM	
LD601	0601-000517	LED-IR:RECTANGULA,4x6.0mm,75mW,6V,950		R680	2001-000429	R-CARBON:1KOHM,5%,1/8W,AA,TP,1.8X3.2MM	
PT601	0604-001122	PHOTO-INTERRUPTER:TR,0.065%,150mW,DIP-4,		R682	2001-000522	R-CARBON:22KOHM,5%,1/8W,AA,TP,1.8X3.2MM	
PT602	0604-001122	PHOTO-INTERRUPTER:TR,0.065%,150mW,DIP-4,		R686	2001-000290	R-CARBON:10KOHM,5%,1/8W,AA,TP,1.8X3.2MM	
Q601	0501-000303	TR-SMALL SIGNAL:KSA733,PNP,250mW,TO-92,T		R687	2001-000290	R-CARBON:10KOHM,5%,1/8W,AA,TP,1.8X3.2MM	

Loc.No	Part No	Description ; Specification	Remark	Loc.No	Part No	Description ; Specification	Remark
R689	2001-000864	R-CARBON:56KOHM,5%,1/8W,AA,TP,1.8X3.2MM		C346	2401-003107	C-AL:47uF,20%,16V,GP,TP,5x7,5	
R690	2001-000734	R-CARBON:4.7KOHM,5%,1/8W,AA,TP,1.8X3.2MM		C347	2202-000286	C-CERAMIC,MLC-AXIAL:56pF,5%,50V,SL,TP,1.	
R691	2001-000429	R-CARBON:1KOHM,5%,1/8W,AA,TP,1.8X3.2MM		C349	2202-000849	C-CERAMIC,MLC-AXIAL:18pF,5%,50V,CH,TP,3.	
R692	2001-000832	R-CARBON:510OHM,5%,1/8W,AA,TP,1.8X3.2MM		C350	2202-000797	C-CERAMIC,MLC-AXIAL:10NF,30%,16V,Y5S,TP,	
R693	2001-000515	R-CARBON:220OHM,5%,1/8W,AA,TP,1.8X3.2MM		C360	2202-000849	C-CERAMIC,MLC-AXIAL:18pF,5%,50V,CH,TP,3.	
R694	2001-000290	R-CARBON:10KOHM,5%,1/8W,AA,TP,1.8X3.2MM		C361	2202-000787	C-CERAMIC,MLC-AXIAL:10PF,5%,50V,Y5P,TP,3	
R695	2001-000290	R-CARBON:10KOHM,5%,1/8W,AA,TP,1.8X3.2MM		C370	2202-000205	C-CERAMIC,MLC-AXIAL:22pF,5%,50V,SL,TP,1.	
R699	2001-000429	R-CARBON:1KOHM,5%,1/8W,AA,TP,1.8X3.2MM		C381	2202-000797	C-CERAMIC,MLC-AXIAL:10NF,30%,16V,Y5S,TP,	
RS601	AC34-20100B	SWITCH-REC:-,X-9,-		C390	2202-002037	C-CERAMIC,MLC-AXIAL:100nF,80-20%,50V,Y5V	
S601	0603-001011	PHOTO-TR:NPN,35V,6V,50mA,75mW,BK		C3A01	2401-003122	C-AL:4.7uF,20%,50V,LL,TP,4X7,1.5	
S602	0603-001011	PHOTO-TR:NPN,35V,6V,50mA,75mW,BK		C3A02	2202-002037	C-CERAMIC,MLC-AXIAL:100nF,80-20%,50V,Y5V	
SW601	AC34-20100A	SWITCH-MODE:-,X-9,-		C3A04	2202-002037	C-CERAMIC,MLC-AXIAL:100nF,80-20%,50V,Y5V	
W128	2001-000281	R-CARBON:100OHM,5%,1/8W,AA,TP,1.8X3.2MM		C3A07	2301-000392	C-FILM,PEF:15nF,5%,50V,TP,6.5x8.5x3.2mm,	
XT601	2801-003311	CRYSTAL-UNIT:17.734475MHz,20ppm,28-AAA,1		C3A08	2301-001014	C-FILM,PEF:6.8nF,5%,50V,TP,7x3x6,5mm	
XT603	2801-003293	CRYSTAL-UNIT:10MHz,50ppm,28-AAA,16pF,50o		C3A09	2301-001014	C-FILM,PEF:6.8nF,5%,50V,TP,7x3x6,5mm	
SW701	3404-001076	SWITCH-TACT:12V,50mA,16gf+-50gf,6x6mm,SP		C3A10	2301-000473	C-FILM,PEF:8.2nF,10%,50V,5.7x7x3mm,5mm,T	
SW702	3404-001076	SWITCH-TACT:12V,50mA,16gf+-50gf,6x6mm,SP		C3A11	2301-000253	C-FILM,PEF:39nF,5%,100V,TP,7.5X4.5X12.5M	
SW703	3404-001076	SWITCH-TACT:12V,50mA,16gf+-50gf,6x6mm,SP		C3A12	2401-003107	C-AL:47uF,20%,16V,GP,TP,5x7,5	
SW712	3404-001076	SWITCH-TACT:12V,50mA,16gf+-50gf,6x6mm,SP		C3A13	2301-000161	C-FILM,PEF:12nF,5%,50V,6.5X5.5X3.0X5,5mm	
SW714	3404-001076	SWITCH-TACT:12V,50mA,16gf+-50gf,6x6mm,SP		C3A14	2301-001014	C-FILM,PEF:6.8nF,5%,50V,TP,7x3x6,5mm	
SW715	3404-001076	SWITCH-TACT:12V,50mA,16gf+-50gf,6x6mm,SP		C3A15	2301-000383	C-FILM,PEF:10nF,5%,50V,TP,6x7x3.2mm,5mm	
SW716	3404-001076	SWITCH-TACT:12V,50mA,16gf+-50gf,6x6mm,SP		C3A16	2401-002299	C-AL:4.7uF,20%,50V,GP,TP,5x7,5	
SW720	3404-000165	SWITCH-TACT:12V,50mA,16gf+-50gf,6x6mm,S		C3A17	2401-000918	C-AL:22uF,20%,16V,GP,-,6.3x7,5	
<b>AUDIO/VIDEO PARTS</b>				C3A18	2301-000402	C-FILM,PEF:1nF,5%,50V,TP,5x7x2.8mm,5mm	
C301	2401-001919	C-AL:2.2UF,20%,50V,-,TP,4X7MM,5		C3A23	2401-001168	C-AL:33uF,20%,16V,GP,TP,6.3x5,2.5mm	
C302	2301-000283	C-FILM,PEF:47nF,5%,100V,TP,7.3X7X3.2X5,5		C3A24	2202-002037	C-CERAMIC,MLC-AXIAL:100nF,80-20%,50V,Y5V	
C303	2401-000598	C-AL:1uF,20%,50V,GP,TP,4x7,5		C3A25	2401-000918	C-AL:22uF,20%,16V,GP,-,6.3x7,5	
C304	2202-000216	C-CERAMIC,MLC-AXIAL:027NF,5%,50V,SL,TP,		C3A29	2202-002037	C-CERAMIC,MLC-AXIAL:100nF,80-20%,50V,Y5V	
C305	2202-000164	C-CERAMIC,MLC-AXIAL:18NF,10%,50V,Y5P,TP		C3A30	2401-003107	C-AL:47uF,20%,16V,GP,TP,5x7,5	
C306	2202-000814	C-CERAMIC,MLC-AXIAL:390pF,10%,50V,Y5P,TP		C3A40	2401-000414	C-AL:10uF,20%,16V,GP,TP,4x7,5	
C307	2202-000162	C-CERAMIC,MLC-AXIAL:015NF,5%,50V,SL,TP,		CN301	3708-000391	CONNECTOR-FPC/FC/PIC:10P;1.25MM,STRAIGHT	
C308	2202-000797	C-CERAMIC,MLC-AXIAL:10NF,30%,16V,Y5S,TP,		CN3A01	3708-001302	CONNECTOR-FPC/FC/PIC:7P;1.25mm,STRAIGHT,	
C309	2401-000598	C-AL:1uF,20%,50V,GP,TP,4x7,5		CN3A02	3711-002445	CONNECTOR-HEADER-BOX,2P2R,1.5MM,STRAIGHT	
C310	2401-000918	C-AL:22uF,20%,16V,GP,-,6.3x7,5		D302	0401-000101	DIODE-SWITCHING:1N4148,100V,200mA,DO-35,	
C311	2401-000414	C-AL:10uF,20%,16V,GP,TP,4x7,5		FL3A01	AC27-80100A	COIL-OSC:1260N-K5272YHC-K,-AM	
C313	2202-000173	C-CERAMIC,MLC-AXIAL:1nF,10%,50V,Y5P,TP,1		IC301	1204-001403	IC-VIDEO PROCESS:LA71570M,QFP:100P,-,PLA	
C314	2401-001775	C-AL:470nF,20%,50V,GP,TP,4x7,5		L301	2701-000206	INDUCTOR-AXIAL:56UH,5%,2.4X3.4MM	
C315	2401-000414	C-AL:10uF,20%,16V,GP,TP,4x7,5		L302	AC27-92001B	COIL-PEAKING AXIAL:BAL04ST101K,-,-,-,-	
C316	2202-002037	C-CERAMIC,MLC-AXIAL:100nF,80-20%,50V,Y5V		L304	AC27-92001B	COIL-PEAKING AXIAL:BAL04ST101K,-,-,-,-	
C318	2202-002037	C-CERAMIC,MLC-AXIAL:100nF,80-20%,50V,Y5V		L305	AC27-92001B	COIL-PEAKING AXIAL:BAL04ST101K,-,-,-,-	
C320	2401-000598	C-AL:1uF,20%,50V,GP,TP,4x7,5		L306	2701-000119	INDUCTOR-AXIAL:120UH,5%,2.4X3.4MM	
C321	2401-000414	C-AL:10uF,20%,16V,GP,TP,4x7,5		L3A01	2702-000120	INDUCTOR-RADIAL:15mH,5%,6.2x7.4mm	
C322	2401-000598	C-AL:1uF,20%,50V,GP,TP,4x7,5		L3A02	2702-000106	INDUCTOR-RADIAL:100uH,5%,6.2x7.4mm	
C323	2202-000797	C-CERAMIC,MLC-AXIAL:10NF,30%,16V,Y5S,TP,		L3A03	2702-000106	INDUCTOR-RADIAL:100uH,5%,6.2x7.4mm	
C324	2202-000797	C-CERAMIC,MLC-AXIAL:10NF,30%,16V,Y5S,TP,		Q302	0501-000303	TR-SMALL SIGNAL:KSA733,PNP,250mW,TO-92,T	
C325	2202-000797	C-CERAMIC,MLC-AXIAL:10NF,30%,16V,Y5S,TP,		Q303	0501-000398	TR-SMALL SIGNAL:KSC945,NPN,250mW,TO-92,T	
C326	2202-002037	C-CERAMIC,MLC-AXIAL:100nF,80-20%,50V,Y5V		Q304	0501-000398	TR-SMALL SIGNAL:KSC945,NPN,250mW,TO-92,T	
C327	2401-003107	C-AL:47uF,20%,16V,GP,TP,5x7,5		Q308	0501-000398	TR-SMALL SIGNAL:KSC945,NPN,250mW,TO-92,T	
C328	2202-000797	C-CERAMIC,MLC-AXIAL:10NF,30%,16V,Y5S,TP,		Q3A01	0501-000303	TR-SMALL SIGNAL:KSA733,PNP,250mW,TO-92,T	
C329	2202-000797	C-CERAMIC,MLC-AXIAL:10NF,30%,16V,Y5S,TP,		Q3A02	0504-000203	TR-DIGITAL:KSR1008,NPN,300MW,47K/47K,TO-	
C330	2202-000797	C-CERAMIC,MLC-AXIAL:10NF,30%,16V,Y5S,TP,		Q3A03	0501-000442	TR-SMALL SIGNAL:KTC3203-Y,NPN,400MW,TO-9	
C331	2401-003107	C-AL:47uF,20%,16V,GP,TP,5x7,5		Q3A04	0501-000442	TR-SMALL SIGNAL:KTC3203-Y,NPN,400MW,TO-9	
C332	2202-002037	C-CERAMIC,MLC-AXIAL:100nF,80-20%,50V,Y5V		Q3A05	0501-000442	TR-SMALL SIGNAL:KTC3203-Y,NPN,400MW,TO-9	
C333	2401-001915	C-AL:1uF,20%,50V,GP,TP,3x5,5		Q3A06	0501-000303	TR-SMALL SIGNAL:KSA733,PNP,250mW,TO-92,T	
C334	2202-002055	C-CERAMIC,MLC-AXIAL:47nF,+80-20%,50V,Y5V		R301	2001-000449	R-CARBON:2.2KOHM,5%,1/8W,AA,TP,1.8X3.2MM	
C335	2401-001915	C-AL:1uF,20%,50V,GP,TP,3x5,5		R302	2001-000429	R-CARBON:1KOHM,5%,1/8W,AA,TP,1.8X3.2MM	
C336	2401-001915	C-AL:1uF,20%,50V,GP,TP,3x5,5		R304	2001-000977	R-CARBON:8.2KOHM,5%,1/8W,AA,TP,1.8X3.2MM	
C337	2202-000807	C-CERAMIC,MLC-AXIAL:22nF,+80-20%,25V,Y5V		R305	2001-000258	R-CARBON:1.8KOHM,5%,1/8W,AA,TP,1.8X3.2MM	
C338	2202-000797	C-CERAMIC,MLC-AXIAL:10NF,30%,16V,Y5S,TP,		R306	2001-000232	R-CARBON:1.3KOHM,5%,1/8W,AA,TP,1.8X3.2MM	
C339	2202-002055	C-CERAMIC,MLC-AXIAL:47nF,+80-20%,50V,Y5V		R308	2001-000429	R-CARBON:1KOHM,5%,1/8W,AA,TP,1.8X3.2MM	
C340	2202-000807	C-CERAMIC,MLC-AXIAL:22nF,+80-20%,25V,Y5V		R309	2001-000723	R-CARBON:4.3KOHM,5%,1/8W,AA,TP,1.8X3.2MM	
C341	2401-003107	C-AL:47uF,20%,16V,GP,TP,5x7,5		R311	2001-000429	R-CARBON:1KOHM,5%,1/8W,AA,TP,1.8X3.2MM	
C342	2202-002037	C-CERAMIC,MLC-AXIAL:100nF,80-20%,50V,Y5V		R312	2001-000221	R-CARBON:1.2KOHM,5%,1/8W,AA,TP,1.8X3.2MM	
C343	2202-000797	C-CERAMIC,MLC-AXIAL:10NF,30%,16V,Y5S,TP,		R313	2001-000515	R-CARBON:220OHM,5%,1/8W,AA,TP,1.8X3.2MM	
C345	2202-000787	C-CERAMIC,MLC-AXIAL:10PF,5%,50V,Y5P,TP,3		R314	2001-000924	R-CARBON:680OHM,5%,1/8W,AA,TP,1.8X3.2MM	
				R315	2001-000472	R-CARBON:2.7KOHM,5%,1/8W,AA,TP,1.8X3.2MM	

Electrical Parts List

Loc.No	Part No	Description ; Specification	Remark
R316	2001-000221	R-CARBON:1.2KOHM,5%,1/8W,AA,TP,1.8X3.2MM	
R317	2001-000003	R-CARBON:330OHM,5%,1/8W,AA,TP,1.8X3.2MM	
R318	2001-000003	R-CARBON:330OHM,5%,1/8W,AA,TP,1.8X3.2MM	
R320	2001-000009	R-CARBON:20KOHM,5%,1/8W,AA,TP,1.8X3.2MM	
R321	2001-000290	R-CARBON:10KOHM,5%,1/8W,AA,TP,1.8X3.2MM	
R322	2001-000539	R-CARBON:24KOHM,5%,1/8W,AA,TP,1.8X3.2MM	
R325	2001-000472	R-CARBON:2.7KOHM,5%,1/8W,AA,TP,1.8X3.2MM	
R326	2001-000429	R-CARBON:1KOHM,5%,1/8W,AA,TP,1.8X3.2MM	
R327	2001-000832	R-CARBON:510OHM,5%,1/8W,AA,TP,1.8X3.2MM	
R328	2001-000472	R-CARBON:2.7KOHM,5%,1/8W,AA,TP,1.8X3.2MM	
R330	2001-000734	R-CARBON:4.7KOHM,5%,1/8W,AA,TP,1.8X3.2MM	
R331	2001-000515	R-CARBON:220OHM,5%,1/8W,AA,TP,1.8X3.2MM	
R332	2001-000281	R-CARBON:100OHM,5%,1/8W,AA,TP,1.8X3.2MM	
R333	2001-000281	R-CARBON:100OHM,5%,1/8W,AA,TP,1.8X3.2MM	
R334	2001-000281	R-CARBON:100OHM,5%,1/8W,AA,TP,1.8X3.2MM	
R335	2001-000008	R-CARBON:15KOHM,5%,1/8W,AA,TP,1.8X3.2MM	
R336	2001-000800	R-CARBON:5.1KOHM,5%,1/8W,AA,TP,1.8X3.2MM	
R340	2001-000802	R-CARBON:5.6Kohm,5%,1/8W,AA,TP,1.8x3.2m	
R3A01	2001-000331	R-CARBON:12KOHM,5%,1/8W,AA,TP,1.8X3.2MM	
R3A04	2001-000241	R-CARBON:1.5KOHM,5%,1/8W,AA,TP,1.8X3.2MM	
R3A05	2001-000660	R-CARBON:33KOHM,5%,1/8W,AA,TP,1.8X3.2MM	
R3A06	2001-000325	R-CARBON:120OHM,5%,1/8W,AA,TP,1.8X3.2MM	
R3A07	2001-000645	R-CARBON:330KOHM,5%,1/8W,AA,TP,1.8X3.2MM	
R3A08	2001-000331	R-CARBON:12KOHM,5%,1/8W,AA,TP,1.8X3.2MM	
R3A11	2001-000258	R-CARBON:1.8KOHM,5%,1/8W,AA,TP,1.8X3.2MM	
R3A12	2001-000458	R-CARBON:2.2OHM,5%,1/8W,AA,TP,1.8X3.2MM	
R3A13	2001-000780	R-CARBON:470OHM,5%,1/8W,AA,TP,1.8X3.2MM	
R3A14	2001-000522	R-CARBON:22KOHM,5%,1/8W,AA,TP,1.8X3.2MM	
R3A16	2001-000290	R-CARBON:10KOHM,5%,1/8W,AA,TP,1.8X3.2MM	
R3A17	2001-000429	R-CARBON:1KOHM,5%,1/8W,AA,TP,1.8X3.2MM	
R3A18	2001-000429	R-CARBON:1KOHM,5%,1/8W,AA,TP,1.8X3.2MM	
R3A19	2001-000405	R-CARBON:180OHM,5%,1/8W,AA,TP,1.8X3.2MM	
R3A21	2001-000904	R-CARBON:620OHM,5%,1/8W,AA,TP,1.8X3.2MM	
R3A22	2001-000006	R-CARBON:2.4KOHM,5%,1/8W,AA,TP,1.8X3.2MM	
R3A23	2001-000802	R-CARBON:5.6Kohm,5%,1/8W,AA,TP,1.8x3.2m	
R3A24	2001-000522	R-CARBON:22KOHM,5%,1/8W,AA,TP,1.8X3.2MM	
R3A25	2001-000221	R-CARBON:1.2KOHM,5%,1/8W,AA,TP,1.8X3.2MM	
R3A26	2001-000331	R-CARBON:12KOHM,5%,1/8W,AA,TP,1.8X3.2MM	
R3A28	2001-000472	R-CARBON:2.7KOHM,5%,1/8W,AA,TP,1.8X3.2MM	
R3A30	2001-000454	R-CARBON:2.2MOHM,5%,1/8W,AA,TP,1.8X3.2MM	
R3A32	2001-000591	R-CARBON:3.3KOHM,5%,1/8W,AA,TP,1.8X3.2MM	
R3A37	2001-000947	R-CARBON:7.5KOHM,5%,1/8W,AA,TP,1.8X3.2MM	
R3A40	2001-000007	R-CARBON:3KOHM,5%,1/8W,AA,TP,1.8X3.2MM	
XT301	2801-001397	CRYSTAL-UNIT:4.433619MHZ,HC-49/U-S 15PPM	
XT302	2801-003399	CRYSTAL-UNIT:3.579545MHZ,15ppm,28-AAA,S,	

INPUT-OUTPUT PARTS

C401	2401-002165	C-AL:100uF,20%,16V,GP,TP,6.3x7,5	
C402	2202-000797	C-CERAMIC,MLC-AXIAL:10NF,30%,16V,Y5S,TP,	
C403	2401-002144	C-AL:47uF,20%,16V,GP,TP,5x11,5	
C404	2202-000797	C-CERAMIC,MLC-AXIAL:10NF,30%,16V,Y5S,TP,	
C405	2401-001573	C-AL:47uF,20%,50V,GP,TP,6.3x11,2.5	
C406	2202-000797	C-CERAMIC,MLC-AXIAL:10NF,30%,16V,Y5S,TP,	
C407	2401-002144	C-AL:47uF,20%,16V,GP,TP,5x11,5	
C408	2202-000797	C-CERAMIC,MLC-AXIAL:10NF,30%,16V,Y5S,TP,	
C410	2401-002144	C-AL:47uF,20%,16V,GP,TP,5x11,5	
C411	2202-000830	C-CERAMIC,MLC-AXIAL:82pF,10%,50V,Y5P,TP,	
C412	2202-000121	C-CERAMIC,MLC-AXIAL:100pF,10%,50V,Y5P,TP	
C413	2202-000121	C-CERAMIC,MLC-AXIAL:100pF,10%,50V,Y5P,TP	
C414	2202-000121	C-CERAMIC,MLC-AXIAL:100pF,10%,50V,Y5P,TP	
C415	2202-000121	C-CERAMIC,MLC-AXIAL:100pF,10%,50V,Y5P,TP	
D401	0402-000127	DIODE-RECTIFIER:1N4002,100V,1A,DO-41,TP	
D402	0401-000101	DIODE-SWITCHING:1N4148,100V,200mA,DO-35,	
D403	0401-000101	DIODE-SWITCHING:1N4148,100V,200mA,DO-35,	
IC5103	AC14-12002V	IC:KA78L09,-,-	
JC801	AC37-20001G	JACK-RCA/DPAE-.6P,HIFI,PI3.3	

Loc.No	Part No	Description ; Specification	Remark
L401	AC27-92001B	COIL-PEAKING AXIAL:BAL04ST101K,-,-,-,-	
Q401	0501-000303	TR-SMALL SIGNAL:KSA733,PNP,250mW,TO-92,T	
Q402	0501-000398	TR-SMALL SIGNAL:KSC945,NPN,250mW,TO-92,T	
R404	2001-001026	R-CARBON:910OHM,5%,1/8W,AA,TP,1.8X3.2MM	
R405	2001-001026	R-CARBON:910OHM,5%,1/8W,AA,TP,1.8X3.2MM	
R406	2001-000780	R-CARBON:470OHM,5%,1/8W,AA,TP,1.8X3.2MM	
R407	2001-000969	R-CARBON:75OHM,5%,1/8W,AA,TP,1.8X3.2MM	
R408	2001-000969	R-CARBON:75OHM,5%,1/8W,AA,TP,1.8X3.2MM	
R411	2001-000281	R-CARBON:100OHM,5%,1/8W,AA,TP,1.8X3.2MM	
R412	2001-000281	R-CARBON:100OHM,5%,1/8W,AA,TP,1.8X3.2MM	
TM401	AD40-20100A	RF-MODULATOR:MDLM3E301A,G/I/K/L/M	
ZD401	0403-000390	DIODE-ZENER:UZP33B,33V,31.4-34.6V,1W,DO-	

HI-FI PARTS

C501	2401-000414	C-AL:10uF,20%,16V,GP,TP,4x7,5	
C502	2401-000598	C-AL:1uF,20%,50V,GP,TP,4x7,5	
C503	2401-000918	C-AL:22uF,20%,16V,GP,-,6.3x7,5	
C504	2401-002299	C-AL:4.7uF,20%,50V,GP,TP,5x7,5	
C505	2301-000383	C-FILM,PEF:10nF,5%,50V,TP,6x7x3.2mm,5mm	
C506	2401-000918	C-AL:22uF,20%,16V,GP,-,6.3x7,5	
C507	2401-000918	C-AL:22uF,20%,16V,GP,-,6.3x7,5	
C508	2301-000445	C-FILM,PEF:4.7nF,5%,50V,TP,5.5x7x3mm,5mm	
C509	2301-000423	C-FILM,PEF:3.3NF,5%,100V,TP,7X10X4.5MM,5	
C510	2401-003107	C-AL:47uF,20%,16V,GP,TP,5x7,5	
C511	2202-002037	C-CERAMIC,MLC-AXIAL:100nF,80-20%,50V,Y5V	
C512	2202-000863	C-CERAMIC,MLC-AXIAL:560pF,10%,50V,Y5P,TP	
C513	2202-000797	C-CERAMIC,MLC-AXIAL:10NF,30%,16V,Y5S,TP,	
C514	2401-000598	C-AL:1uF,20%,50V,GP,TP,4x7,5	
C515	2401-000598	C-AL:1uF,20%,50V,GP,TP,4x7,5	
C516	2301-000423	C-FILM,PEF:3.3NF,5%,100V,TP,7X10X4.5MM,5	
C517	2301-000445	C-FILM,PEF:4.7nF,5%,50V,TP,5.5x7x3mm,5mm	
C518	2401-000918	C-AL:22uF,20%,16V,GP,-,6.3x7,5	
C519	2301-000383	C-FILM,PEF:10nF,5%,50V,TP,6x7x3.2mm,5mm	
C520	2401-002299	C-AL:4.7uF,20%,50V,GP,TP,5x7,5	
C521	2401-000918	C-AL:22uF,20%,16V,GP,-,6.3x7,5	
C522	2401-000598	C-AL:1uF,20%,50V,GP,TP,4x7,5	
C523	2202-002037	C-CERAMIC,MLC-AXIAL:100nF,80-20%,50V,Y5V	
C524	2401-002299	C-AL:4.7uF,20%,50V,GP,TP,5x7,5	
C525	2401-002299	C-AL:4.7uF,20%,50V,GP,TP,5x7,5	
C526	2401-002165	C-AL:100uF,20%,16V,GP,TP,6.3x7,5	
C527	2202-002037	C-CERAMIC,MLC-AXIAL:100nF,80-20%,50V,Y5V	
C529	2401-002299	C-AL:4.7uF,20%,50V,GP,TP,5x7,5	
C531	2401-000598	C-AL:1uF,20%,50V,GP,TP,4x7,5	
C580	2202-002037	C-CERAMIC,MLC-AXIAL:100nF,80-20%,50V,Y5V	
C581	2202-002037	C-CERAMIC,MLC-AXIAL:100nF,80-20%,50V,Y5V	
IC501	1204-001479	IC-AUDIO PROCESSOR:LA72634AM,QFP,64P,400	
L502	AC27-92001B	COIL-PEAKING AXIAL:BAL04ST101K,-,-,-,-	
L503	AC27-92001B	COIL-PEAKING AXIAL:BAL04ST101K,-,-,-,-	
R503	2001-000780	R-CARBON:470OHM,5%,1/8W,AA,TP,1.8X3.2MM	
R504	2001-000472	R-CARBON:2.7KOHM,5%,1/8W,AA,TP,1.8X3.2MM	
R509	2001-000947	R-CARBON:7.5KOHM,5%,1/8W,AA,TP,1.8X3.2MM	
R510	2001-000864	R-CARBON:56KOHM,5%,1/8W,AA,TP,1.8X3.2MM	
R511	2001-000331	R-CARBON:12KOHM,5%,1/8W,AA,TP,1.8X3.2MM	
R512	2001-000660	R-CARBON:33KOHM,5%,1/8W,AA,TP,1.8X3.2MM	
R514	2001-000786	R-CARBON:47KOHM,5%,1/8W,AA,TP,1.8X3.2MM	
R516	2001-000786	R-CARBON:47KOHM,5%,1/8W,AA,TP,1.8X3.2MM	
R517	2001-000947	R-CARBON:7.5KOHM,5%,1/8W,AA,TP,1.8X3.2MM	
R518	2001-000864	R-CARBON:56KOHM,5%,1/8W,AA,TP,1.8X3.2MM	
R523	2001-000508	R-CARBON:220KOHM,5%,1/8W,AA,TP,1.8X3.2MM	
R524	2001-000472	R-CARBON:2.7KOHM,5%,1/8W,AA,TP,1.8X3.2MM	
R525	2001-000577	R-CARBON:2KOHM,5%,1/8W,AA,TP,1.8X3.2MM	
R530	2001-000281	R-CARBON:100OHM,5%,1/8W,AA,TP,1.8X3.2MM	
R531	2001-000281	R-CARBON:100OHM,5%,1/8W,AA,TP,1.8X3.2MM	

Loc.No	Part No	Description ; Specification	Remark	Loc.No	Part No	Description ; Specification	Remark
<b>LED PARTS</b>							
C701	2401-002165	C-AL;100uF,20%,16V,GP,TP,6.3x7.5					
C702	2202-000797	C-CERAMIC,MLC-AXIAL;10NF,30%,16V,Y5S,TP,					
C703	2401-002165	C-AL;100uF,20%,16V,GP,TP,6.3x7.5					
C704	2202-000173	C-CERAMIC,MLC-AXIAL;1nF,10%,50V,Y5P,TP,1					
CN701	3711-001247	CONNECTOR-HEADER;NOWALL,12P,1R,2mm,ANGLE					
D701	0401-000101	DIODE-SWITCHING;1N4148,100V,200mA,DO-35,					
LD702	0601-001201	LED;ROUND,RED,3mm,635nm					
LD703	0601-000497	LED;ROUND,GRN,3.1mm,565nm					
LD704	0601-000497	LED;ROUND,GRN,3.1mm,565nm					
LD705	0601-000497	LED;ROUND,GRN,3.1mm,565nm					
LD706	0601-000497	LED;ROUND,GRN,3.1mm,565nm					
LD707	0601-000497	LED;ROUND,GRN,3.1mm,565nm					
LD708	0601-000497	LED;ROUND,GRN,3.1mm,565nm					
LD709	0601-000497	LED;ROUND,GRN,3.1mm,565nm					
LD710	0601-000497	LED;ROUND,GRN,3.1mm,565nm					
Q701	0501-000398	TR-SMALL SIGNAL;KSC945,NPN,250mW,TO-92,T					
Q721	0501-000290	TR-SMALL SIGNAL;KSA643-Y,PNP,500mW,TO-92					
Q722	0501-000290	TR-SMALL SIGNAL;KSA643-Y,PNP,500mW,TO-92					
Q723	0501-000290	TR-SMALL SIGNAL;KSA643-Y,PNP,500mW,TO-92					
Q724	0501-000290	TR-SMALL SIGNAL;KSA643-Y,PNP,500mW,TO-92					
Q725	0501-000290	TR-SMALL SIGNAL;KSA643-Y,PNP,500mW,TO-92					
Q726	0501-000290	TR-SMALL SIGNAL;KSA643-Y,PNP,500mW,TO-92					
Q727	0501-000290	TR-SMALL SIGNAL;KSA643-Y,PNP,500mW,TO-92					
R702	2001-000362	R-CARBON;1500HM,5%,1/8W,AA,TP,1.8X3.2MM					
R703	2001-000362	R-CARBON;1500HM,5%,1/8W,AA,TP,1.8X3.2MM					
R704	2001-000362	R-CARBON;1500HM,5%,1/8W,AA,TP,1.8X3.2MM					
R705	2001-000362	R-CARBON;1500HM,5%,1/8W,AA,TP,1.8X3.2MM					
R706	2001-000362	R-CARBON;1500HM,5%,1/8W,AA,TP,1.8X3.2MM					
R707	2001-000362	R-CARBON;1500HM,5%,1/8W,AA,TP,1.8X3.2MM					
R708	2001-000969	R-CARBON;750HM,5%,1/8W,AA,TP,1.8X3.2MM					
R709	2001-000362	R-CARBON;1500HM,5%,1/8W,AA,TP,1.8X3.2MM					
R710	2001-000924	R-CARBON;6800HM,5%,1/8W,AA,TP,1.8X3.2MM					
R711	2001-000290	R-CARBON;10KOHM,5%,1/8W,AA,TP,1.8X3.2MM					
R712	2001-000449	R-CARBON;2.2KOHM,5%,1/8W,AA,TP,1.8X3.2MM					
R721	2001-000449	R-CARBON;2.2KOHM,5%,1/8W,AA,TP,1.8X3.2MM					
R722	2001-000449	R-CARBON;2.2KOHM,5%,1/8W,AA,TP,1.8X3.2MM					
R723	2001-000449	R-CARBON;2.2KOHM,5%,1/8W,AA,TP,1.8X3.2MM					
R724	2001-000449	R-CARBON;2.2KOHM,5%,1/8W,AA,TP,1.8X3.2MM					
R725	2001-000449	R-CARBON;2.2KOHM,5%,1/8W,AA,TP,1.8X3.2MM					
R726	2001-000449	R-CARBON;2.2KOHM,5%,1/8W,AA,TP,1.8X3.2MM					
R727	2001-000449	R-CARBON;2.2KOHM,5%,1/8W,AA,TP,1.8X3.2MM					
RM701	AC59-60060A	MODULE-REMOCON;GP1U281R,SHARP,38KHZ,-,-,					
-	<b>AC59-10420A</b>	<b>REMOCON-ASSY;-PR-4914,-14,SV-C11G,S/S</b>					

# MEMO

---

## 5. Schematic Diagrams

---

◆ Block Identification of Main PCB .....	5-2
5-1 S.M.P.S. ....	5-3
5-2 Power Drive .....	5-4
5-3 System Control/Servo/LED .....	5-5
5-4 Audio/Video .....	5-6
5-5 Hi-Fi .....	5-7
5-6 Input-Output .....	5-8
5-7 Remote-Control .....	5-9

**Note**

For schematic Diagram  
 - Resistors are in ohms, 1/8W unless otherwise noted.

**Special note :**

Most semiconductor devices are electrostatically sensitive and therefore require the special handling techniques described under the "electrostatically sensitive (ES) devices" section of this service manual.

**Note :**

Do not use the part number shown on this drawing for ordering. The correct part number is shown in the parts list (may be slightly different or amended since this drawing was prepared).

**Important safety notices :**

Components identified with the mark ⚠ have the special characteristics for safety. When replacing any of these components. Use only the same type.

◆ **Block Identification of Main PCB**

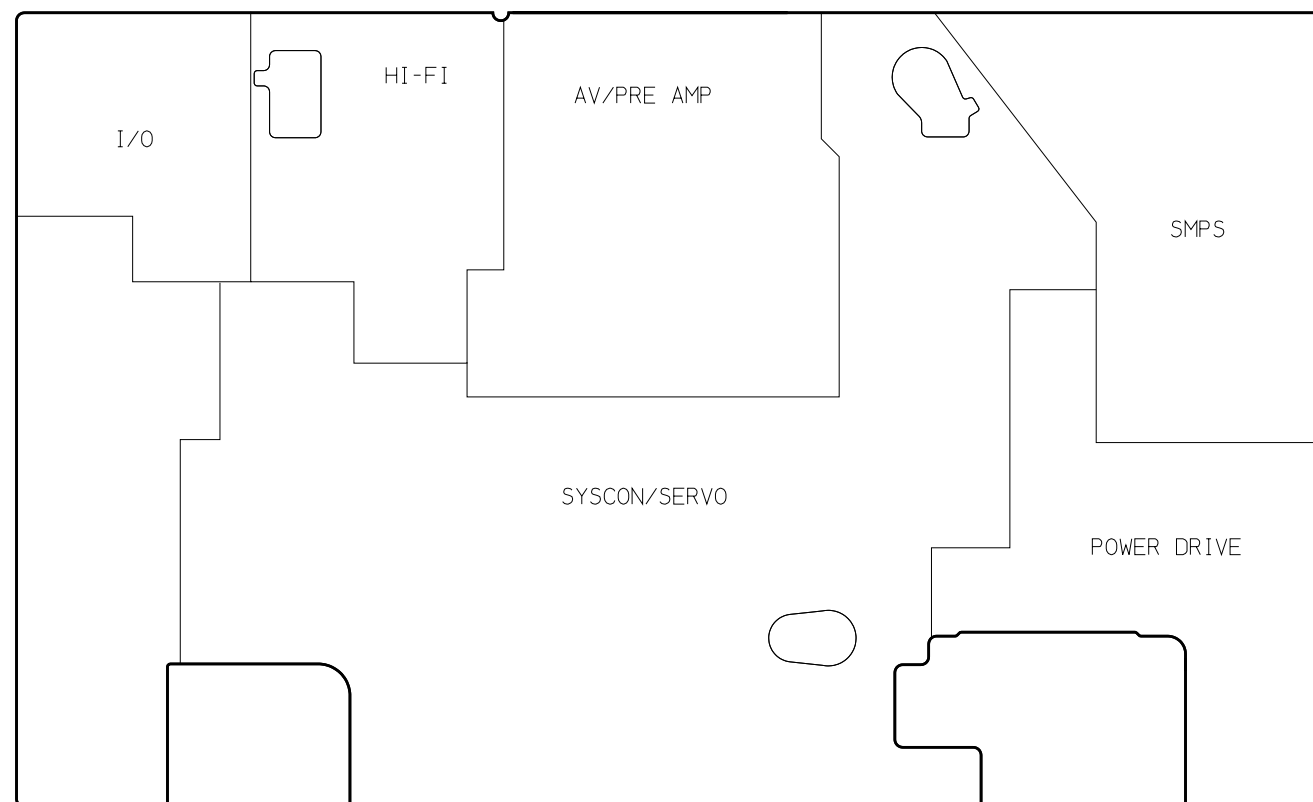

Component Side

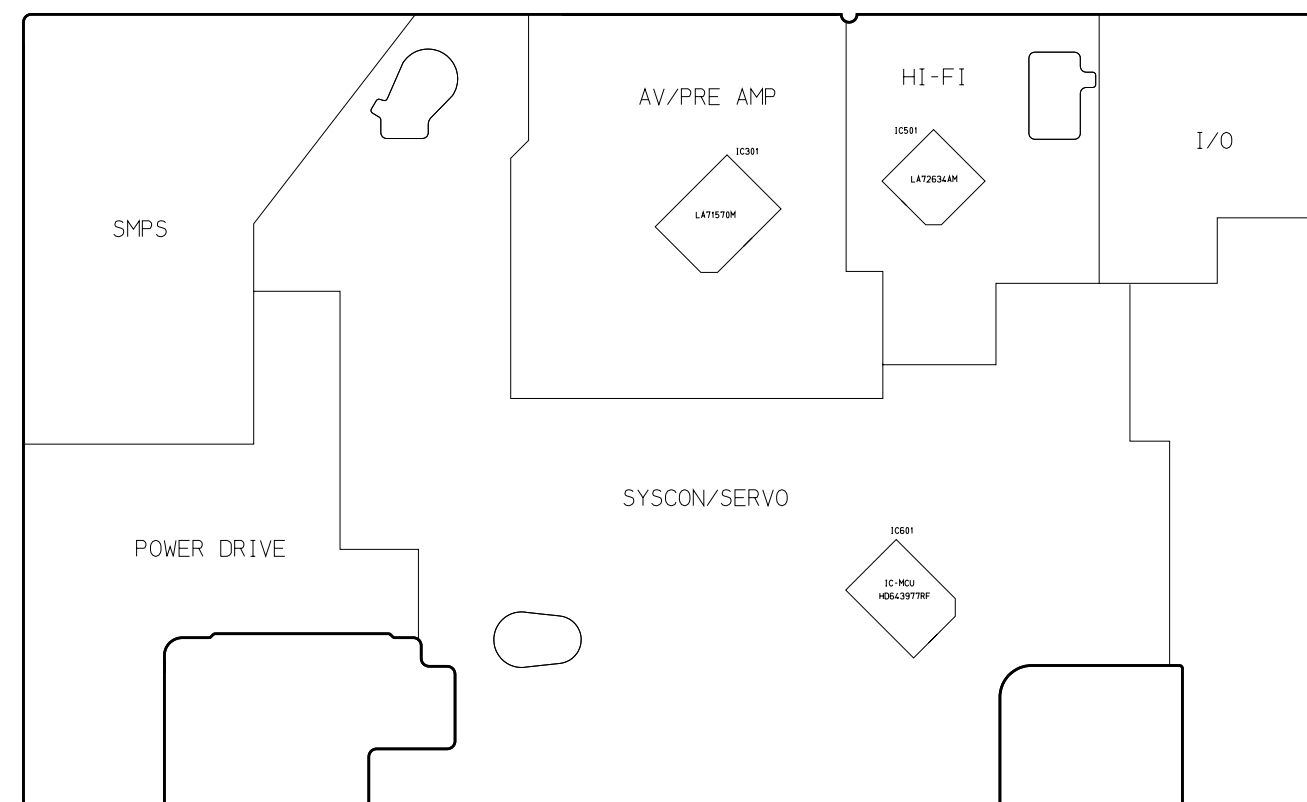

Conductor Side

5-1 S.M.P.S.

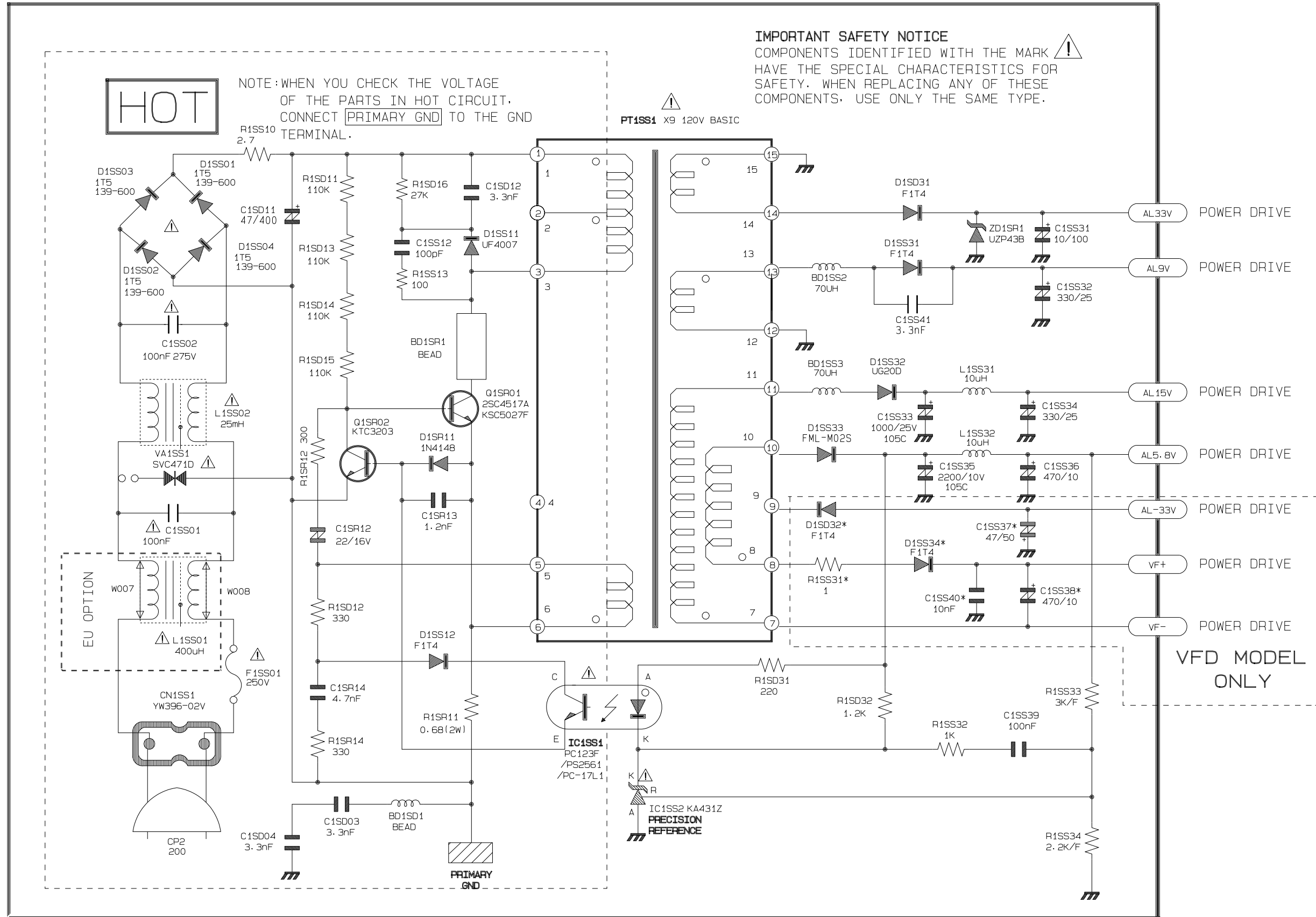

### 5-2 Power Drive

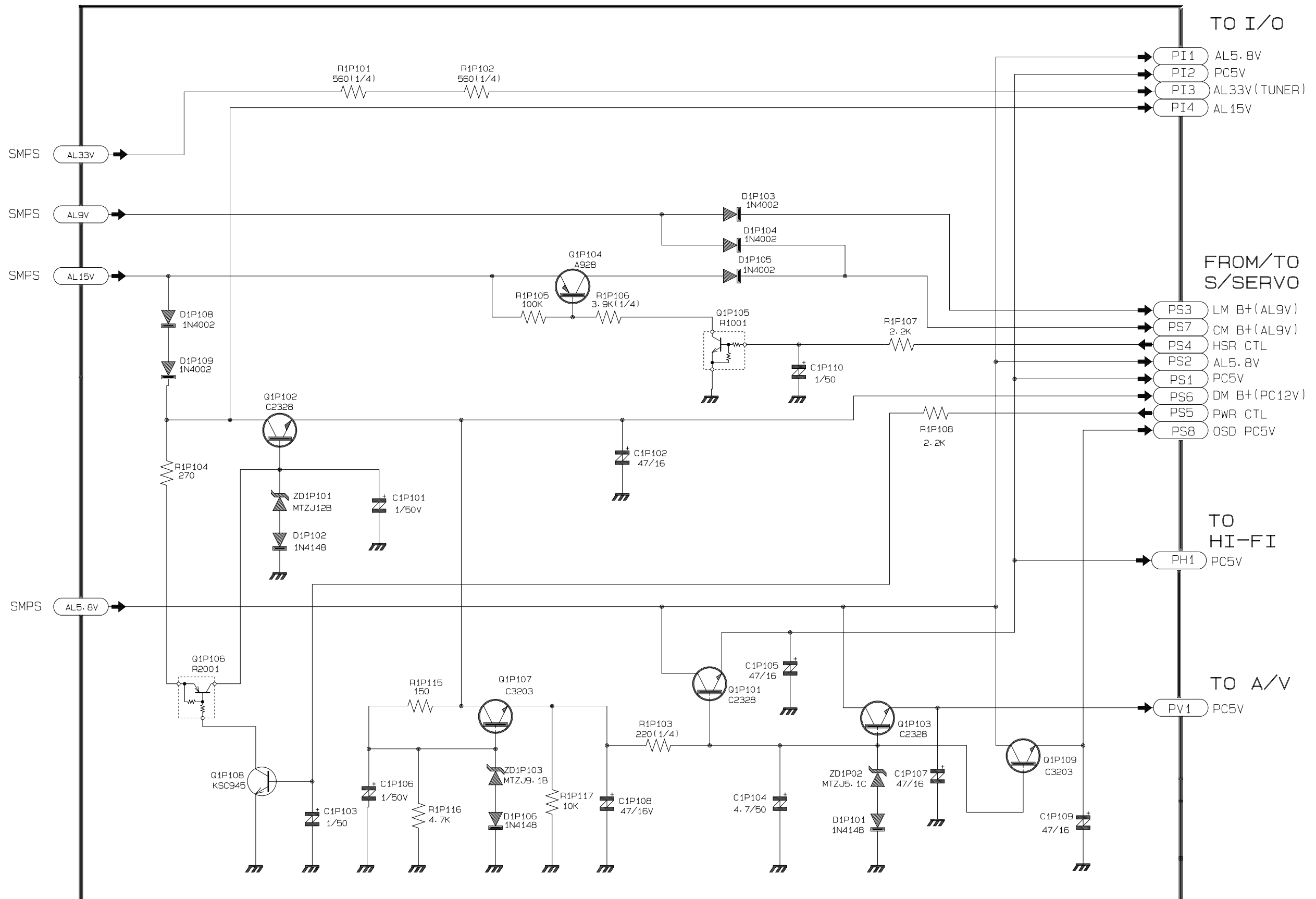

### 5-3 System Control/Servo/LED

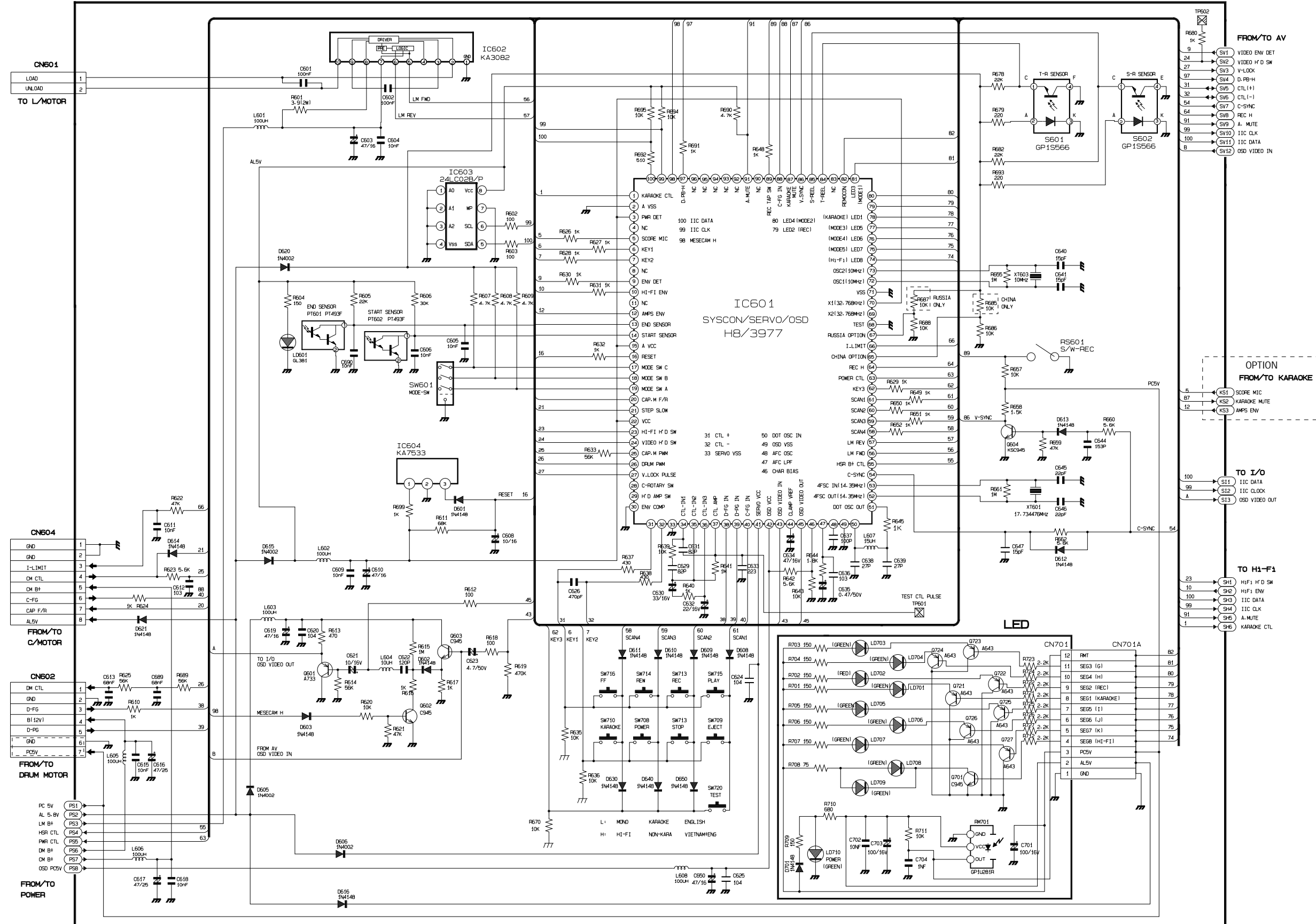

### 5-4 Audio/Video

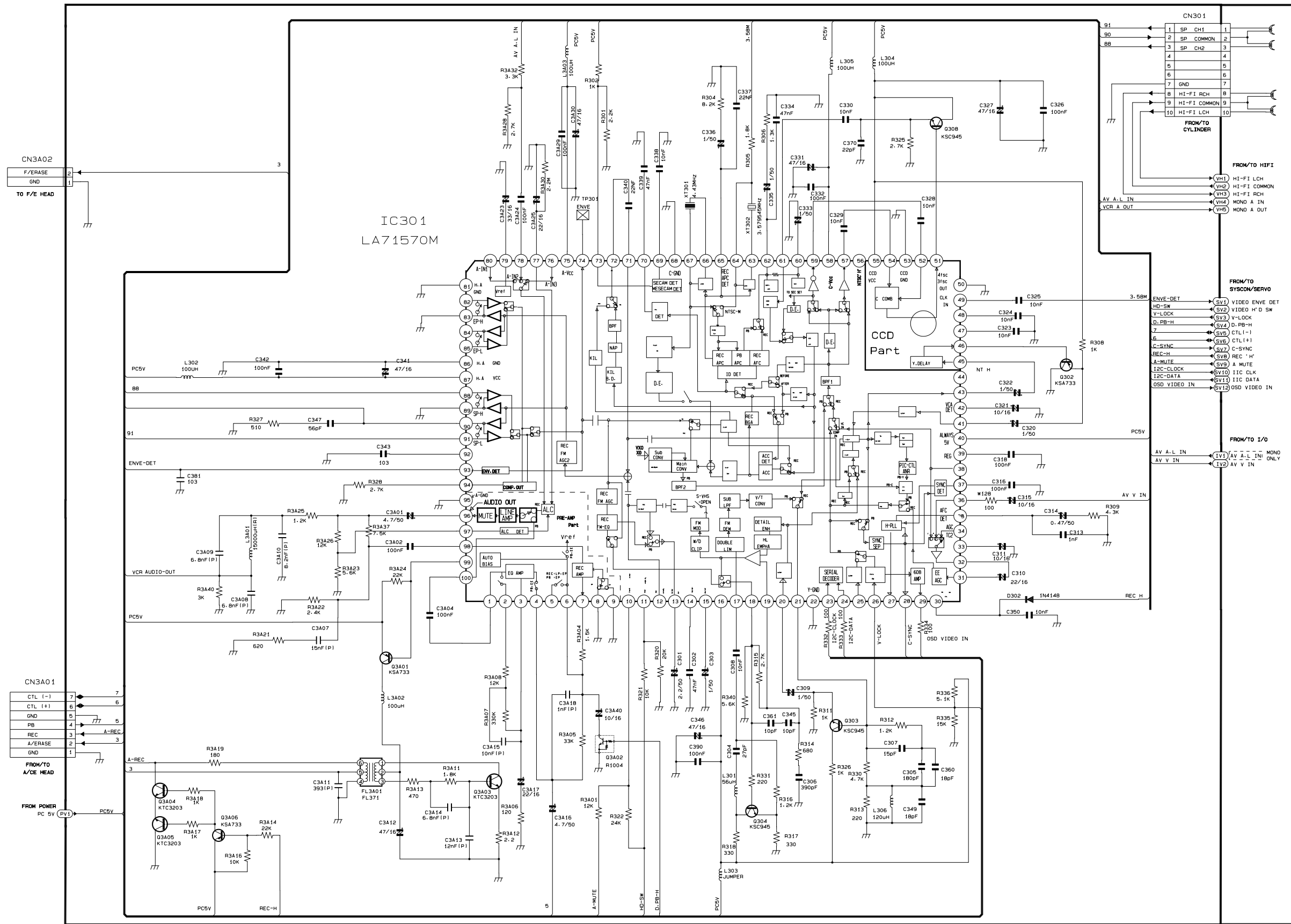

5-5 Hi-Fi

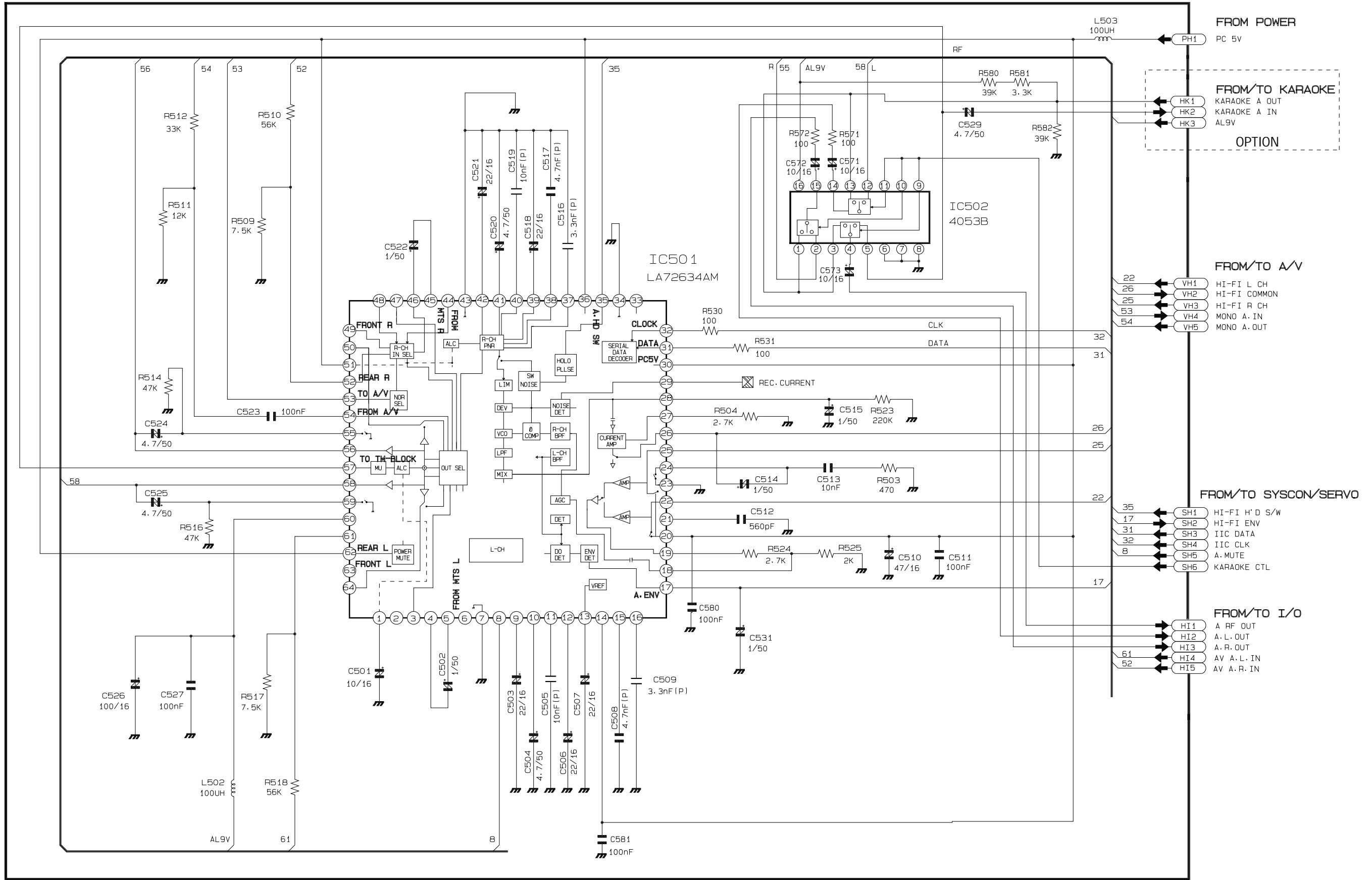

### 5-6 Input-Output

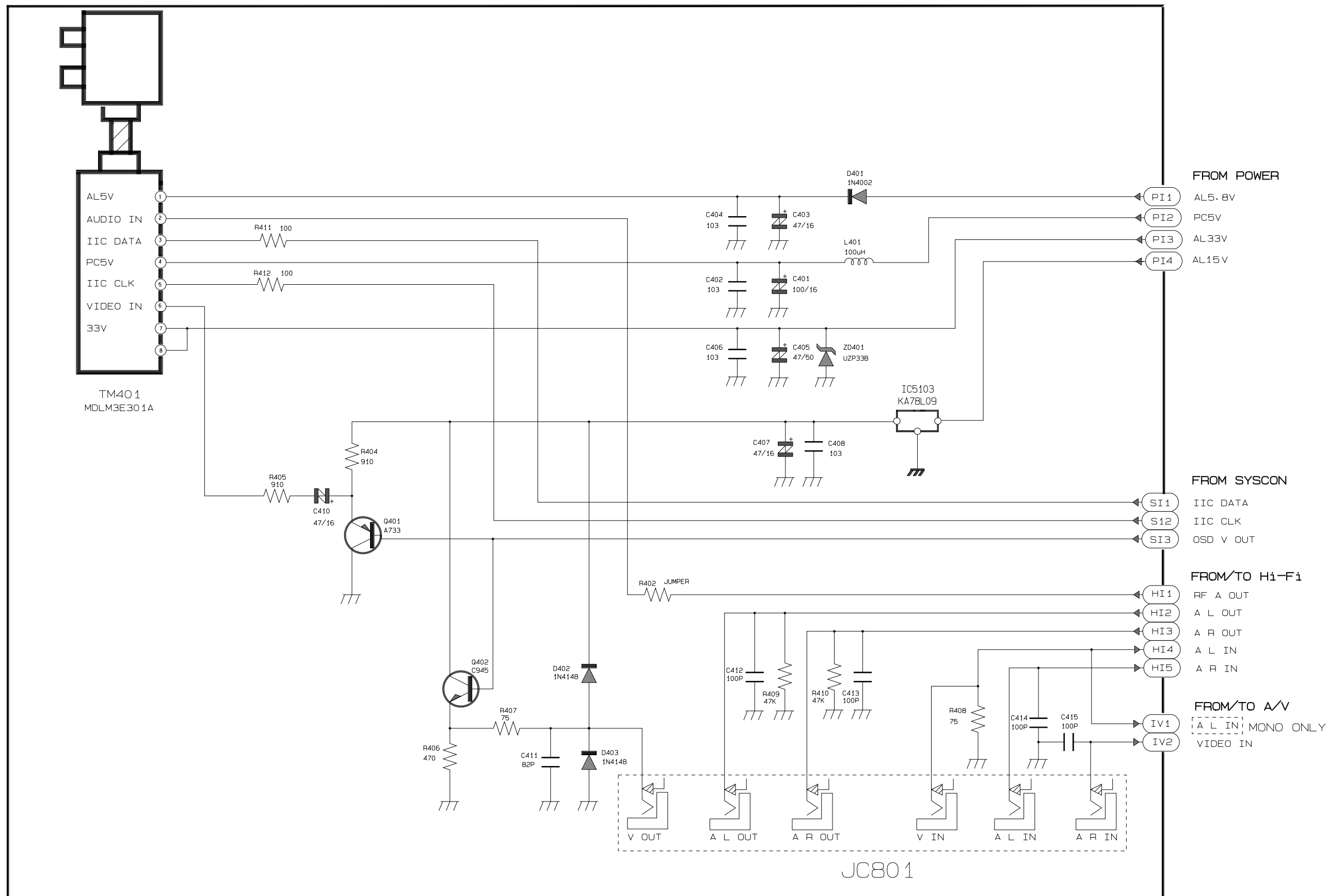

5-7 Remote-Control

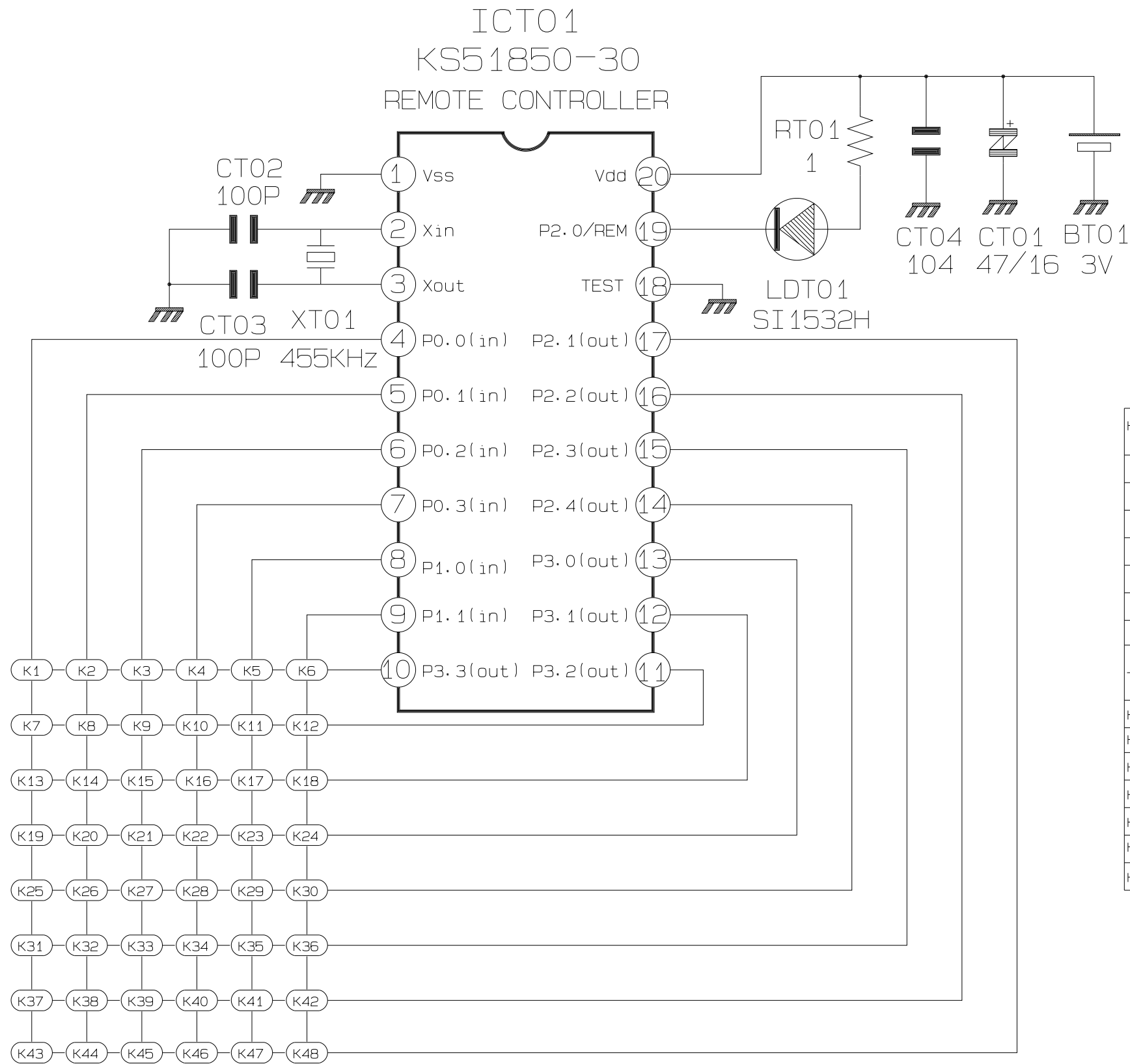

KEY NO.	KEY NAME	KEY NO.	KEY NAME	KEY NO.	KEY NAME
K1	VTR/TV	K17	STOP	K33	INDEX
K2	POWER	K18	P/S	K34	TRK+
K3	1	K19	SLOW DOWN	K35	TRK-
K4	2	K20	REW	K36	DUB
K5	3	K21	PLAY	K37	MARK
K6	4	K22	FF	K38	VCR+
K7	5	K23	CLEAR/RESET	K39	CLK/COUNT
K8	6	K24	DISPLAY	K40	SP/LP
K9	7	K25	MENU	K41	Q-PROGRAM
K10	8	K26	EJECT	K42	OK·ENTER
K11	9	K27	ATR	K43	SYSTEM
K12	CH DOWN	K28	OUTPUT SEL	K44	MODE/KARAOKE
K13	0	K29	INPUT SEL	K45	AFT
K14	CH UP	K30	MONITOR	K46	PICTURE
K15	SLOW UP	K31	ERASE	K47	SHUTTLE-
K16	REC/OTR	K32	TEST	K48	SHUTTLE+

## MEMO



**DX-9R**

MECHANICAL MANUAL

DX-9R

# MECHANICAL *Manual*

◆ File with the SERVICE MANUAL.



## VHS DECK

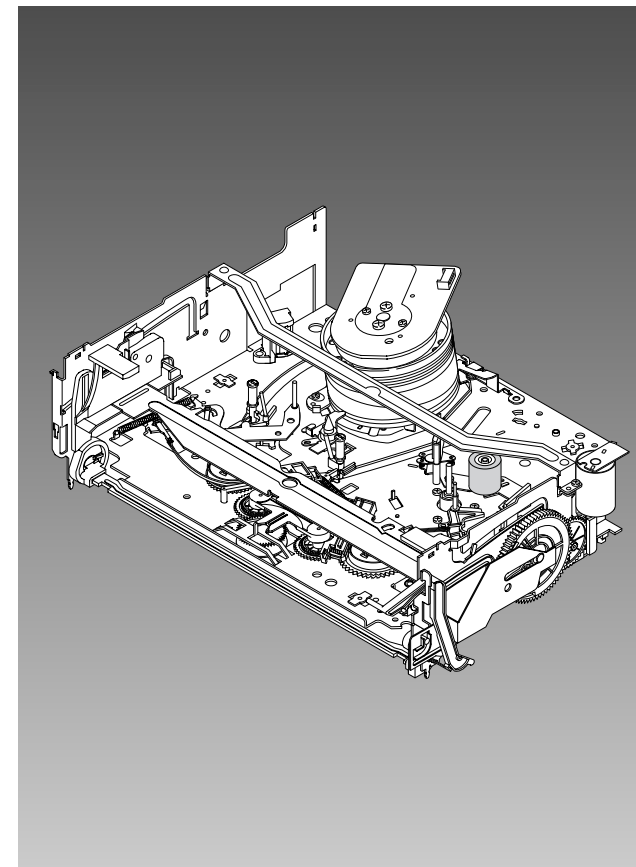

## CONTENTS

1. Disassembly and Reassembly
2. Alignment and Adjustment

---

# 1. Disassembly and Reassembly

---

## 1-1 Deck Parts Locations

---

### 1-1-1 Top View

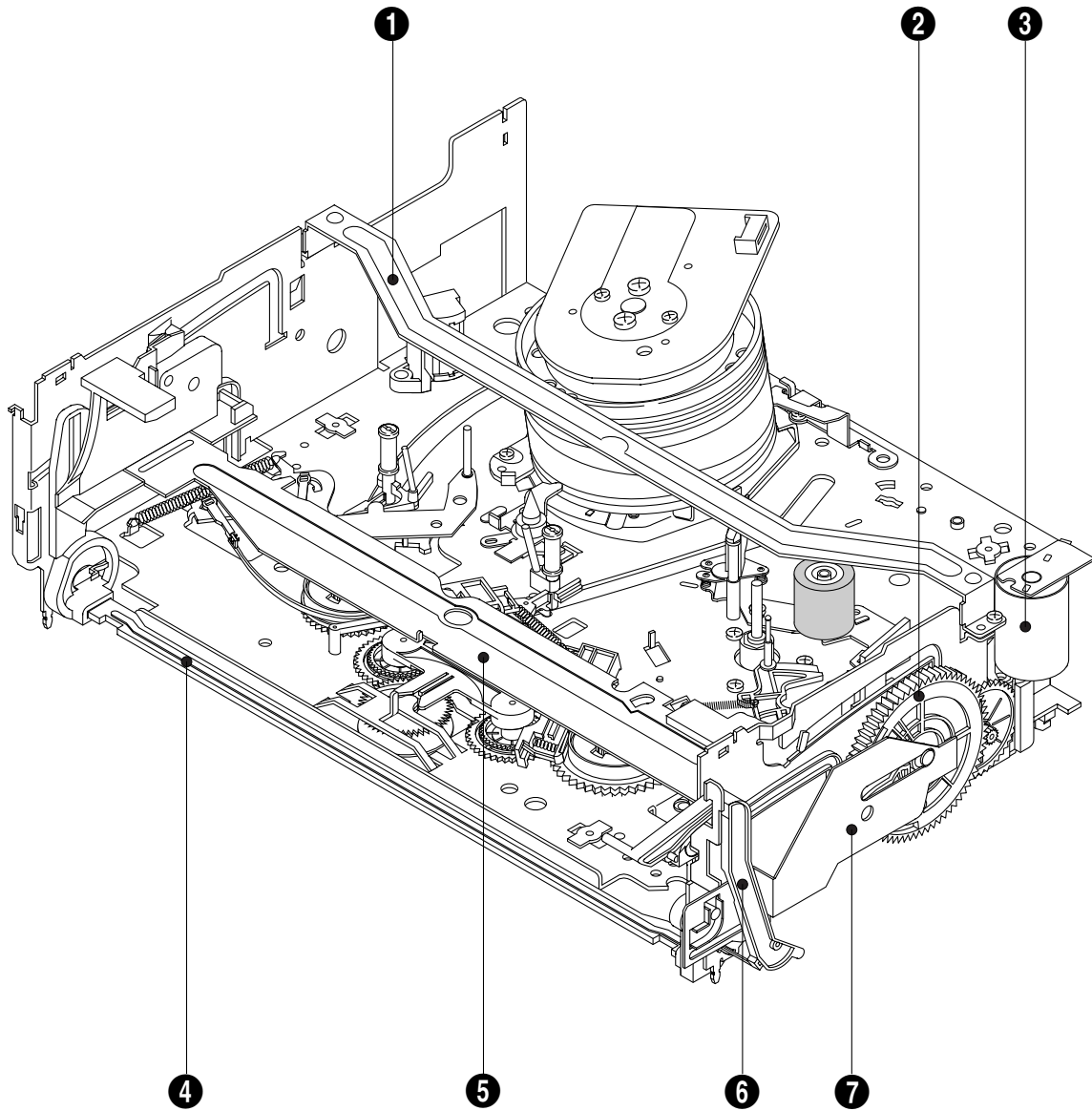

Fig. 1-1 Top parts Location-1

- ❶ BRACKET FL TOP
- ❷ GEAR FL CAM
- ❸ MOTOR LOADING ASS'Y
- ❹ LEVER FL ARM ASS'Y
- ❺ HOLDER FL CASSETTE ASS'Y
- ❻ LEVER FL DOOR
- ❼ SLIDER FL DRIVE

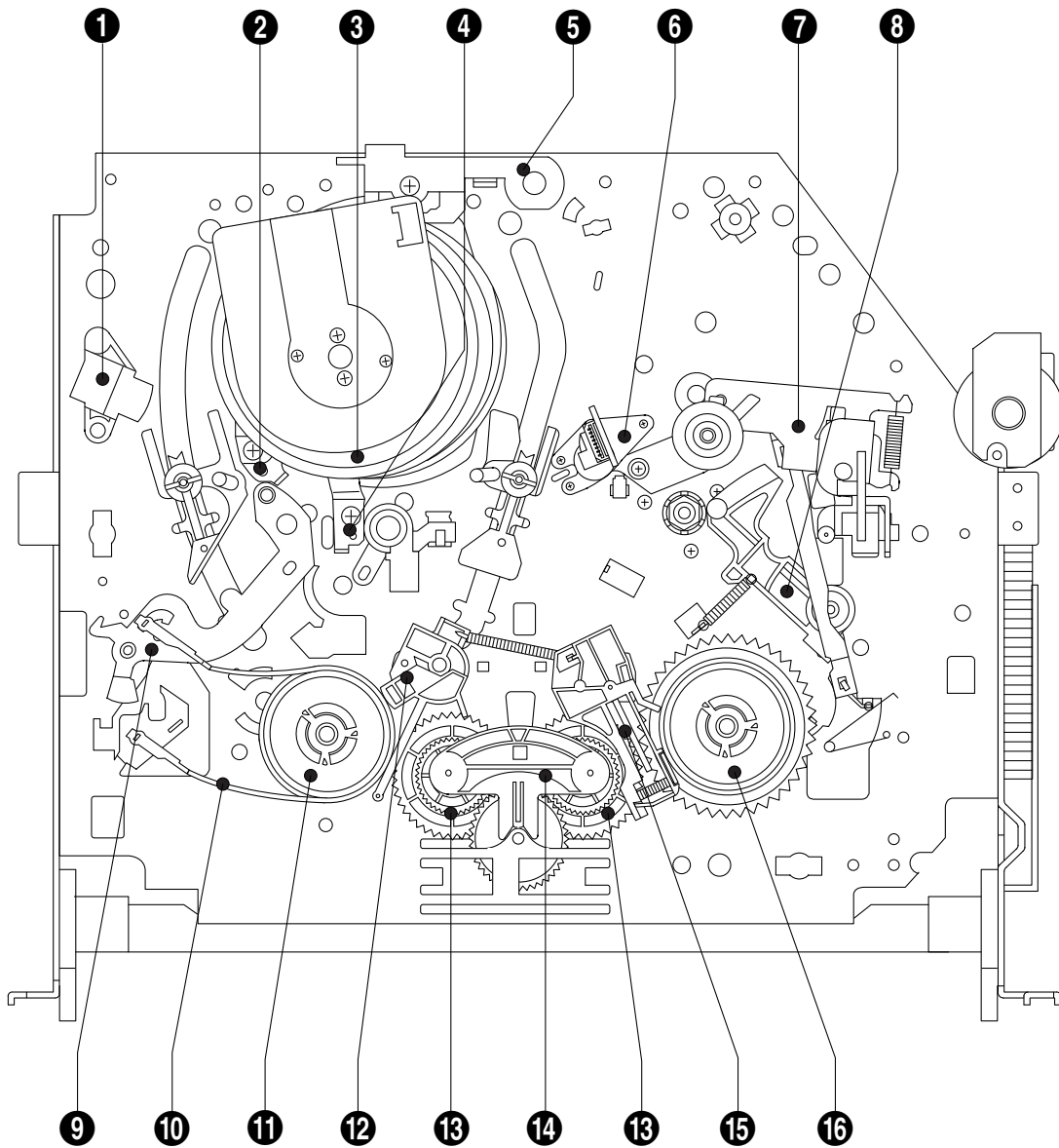

Fig. 1-2 Top Parts Location-2

- |                        |                       |
|------------------------|-----------------------|
| ① FE HEAD              | ⑩ BAND BRAKE ASS'Y    |
| ② PLATE CYLINDER C     | ⑪ DISK S REEL         |
| ③ CYLINDER ASS'Y       | ⑫ LEVER S BRAKE ASS'Y |
| ④ PLATE CYLINDER B     | ⑬ GEAR IDLE           |
| ⑤ PLATE CYLINDER A     | ⑭ LEVER IDLE          |
| ⑥ ACE HEAD ASS'Y       | ⑮ LEVER T BRAKE ASS'Y |
| ⑦ UNIT PINCH ASS'Y     | ⑯ DISK T REEL         |
| ⑧ LEVER #9 GUIDE ASS'Y |                       |
| ⑨ LEVER TENSION ASS'Y  |                       |

### 1-1-2 Bottom View

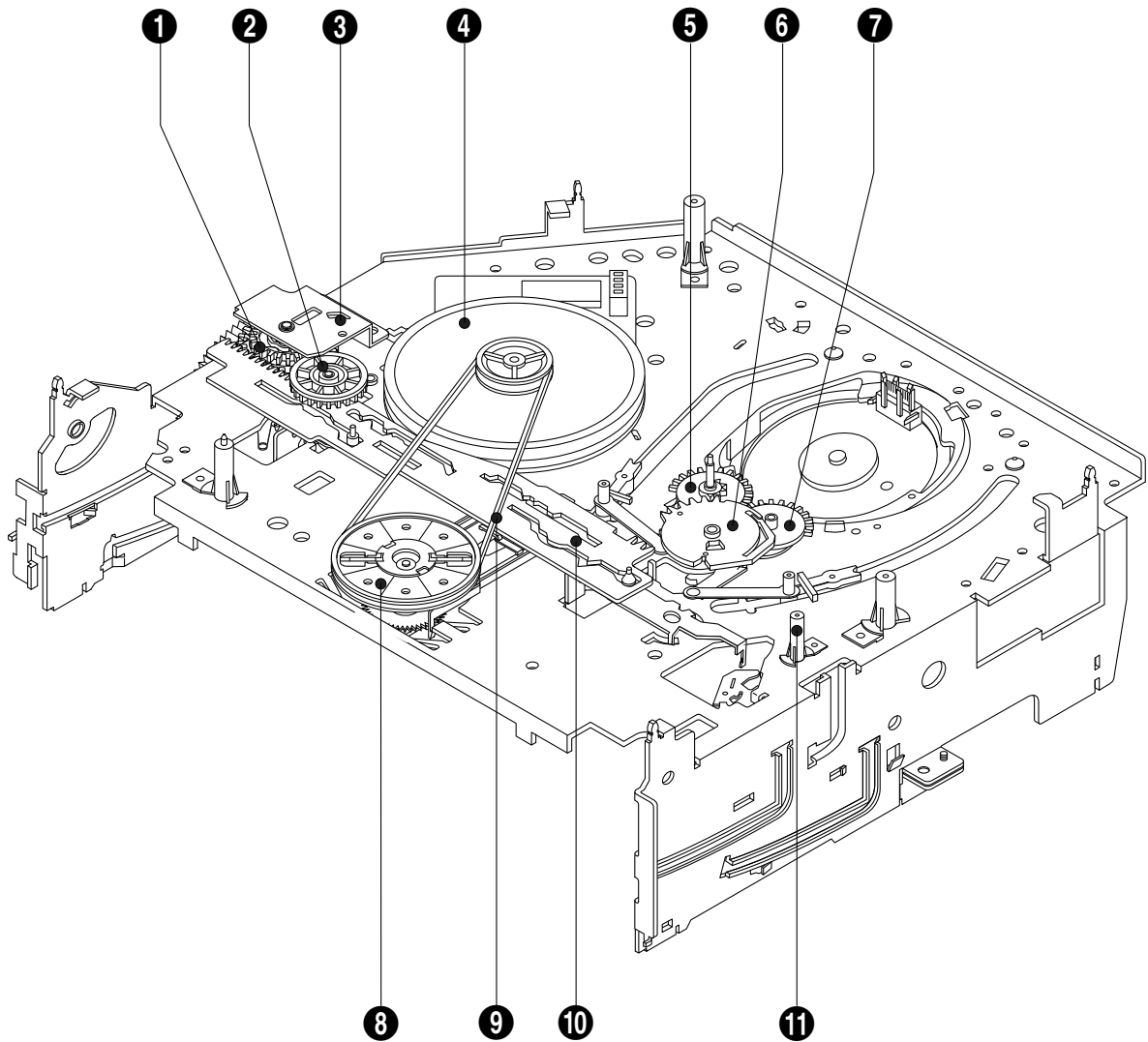

Fig. 1-3 Bottom Parts Location

- ❶ GEAR JOINT 1
- ❷ GEAR JOINT 2
- ❸ BRACKET GEAR
- ❹ MOTOR CAPSTAN ASS'Y
- ❺ LEVER T LOAD ASS'Y
- ❻ GEAR LOADING DRIVE
- ❼ LEVER S LOAD ASS'Y
- ❽ HOLDER CLUTCH ASS'Y
- ❾ BELT PULLEY
- ❿ SLIDER CAM
- ⓫ SLEEVE TENSION

## 1-2 Main Deck

### 1-2-1 Bracket FL Top Removal

- 1) Remove 2 screws ❶.
- 2) Remove the Bracket FL Top ❷.

**Note :** Take care not to change assembly direction.

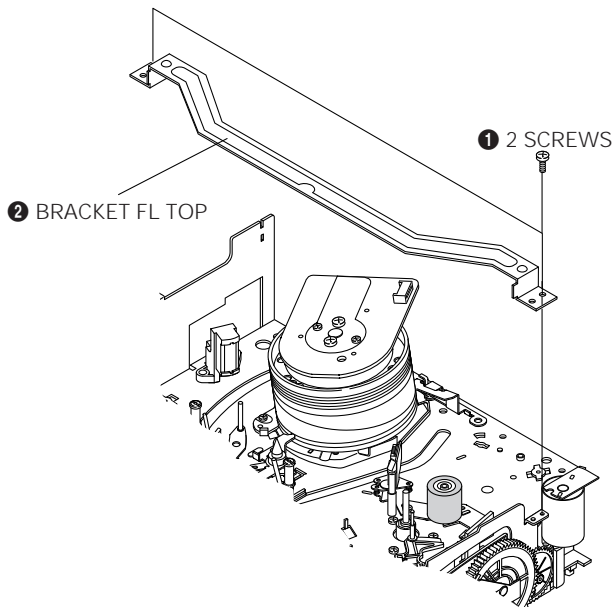

Fig. 1-4 Bracket FL Top Removal

### 1-2-2 Lever FL Door Removal

- 1) Rotate the Lever FL Door ❶ in the direction of arrow "A".
- 2) Release the Hook ❷, remove the Lever FL Door ❶ in the direction of arrow "B".

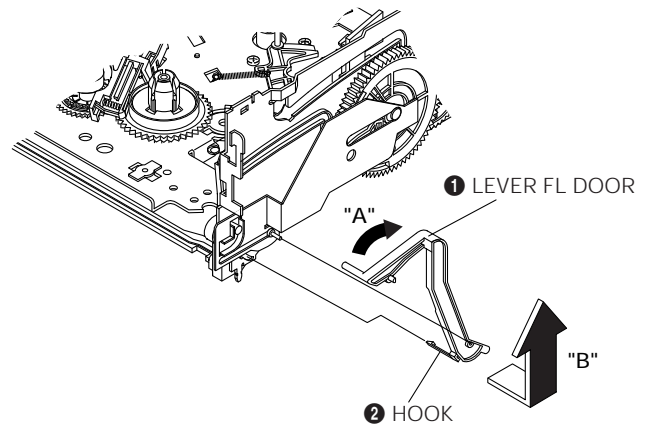

Fig. 1-5 Lever FL Door Removal

### 1-2-3 Holder FL Cassette Ass'y Removal

- 1) Remove the Lever FL Door. (Refer to Fig. 1-5)
- 2) Pull the Holder FL Cassette Ass'y ❶ to the eject position.
- 3) Pull the Holder FL Cassette Ass'y ❶ as grasping the Holder FL Cassette Ass'y ❶ and Lever FL Cassette-R ❷ in the same time to release hooking from Main Base until the Boss [A], [B] of Holder FL Cassette Ass'y ❶ is taken out from the Rail [C], [D].
- 4) Lift the Holder FL Cassette Ass'y ❶ in the direction of arrow "B" in this time, you have to grasp the Lever FL Cassette-R ❷ continuously until the Holder FL Cassette Ass'y ❶ is taken out completely.

**Note** : Be sure to insert Lever FL Cassette-R ❷ in the direction of "A" to prevent separation and breakage of the Lever FL Cassette-R ❷ at disassembling and reassembling.

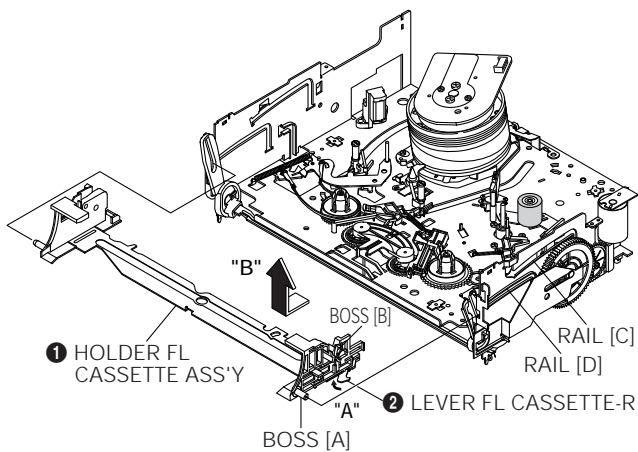

Fig. 1-6 Holder FL Cassette Ass'y Removal

### 1-2-4 Lever FL Arm Ass'y Removal

- 1) Remove the Lever FL Door. (Refer to Fig. 1-5)
- 2) Remove the Holder FL Cassette Ass'y. (Refer to Fig. 1-6)
- 3) Release the Hook ❶ in the direction of arrow "A", pull out the Lever FL Arm Ass'y ❷ from the Boss of Main Base.
- 4) Remove the Lever FL Arm Ass'y ❷ in the direction of arrow "B".

**Assembly** : When reinstalling, be sure to reassemble Lever FL Arm Ass'y ❷ after you insert the Boss ❷ in Groove [A] of Slider FL Drive ❸.

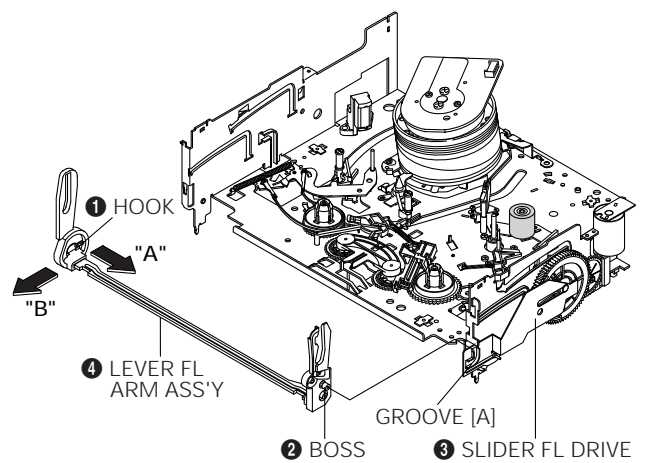

Fig. 1-7 Lever FL Arm Ass'y Removal

### 1-2-5 Slider FL Drive Removal

- 1) Pull the Slider FL Drive ❶ to the front direction.
- 2) Remove the Slider FL Drive ❶ in the direction of arrow. (Refer to Fig. 1-8)

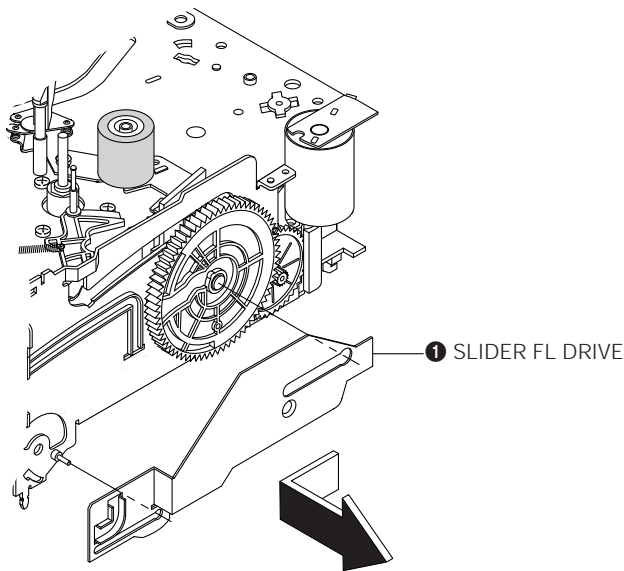

Fig. 1-8 Slider FL Drive Removal

### 1-2-6 Bracket Gear, Gear FL Cam, Gear Joint 1, 2 Removal

- 1) Remove screw ❶.
- 2) Lift the Bracket Gear ❷.
- 3) Remove the Gear FL Cam ❸.
- 4) Lift the Gear Joint 2 ❹, Gear Joint 1 ❺.

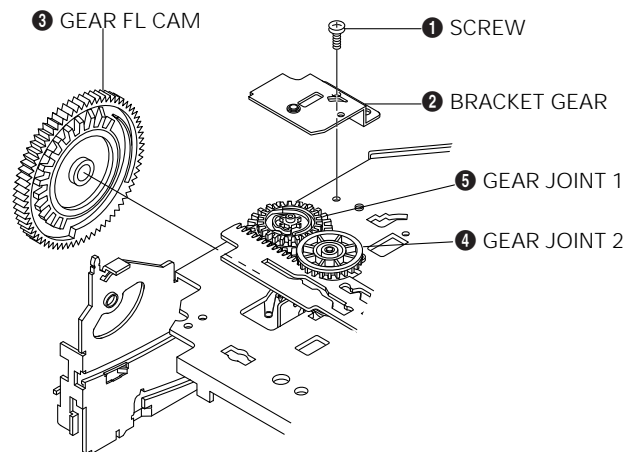

Fig. 1-9 Bracket Gear, Gear FL Cam, Gear Joint 1, 2 Removal

### 1-2-7 Assembly of Gear FL Cam, Gear Joint 1, 2

- 1) Be sure to align dot mark of Gear Joint 1 ❶ with dot mark of Gear Joint 2 ❷ as shown Fig. 1-10 (Refer to Timing Point 1), confirm the Timing Point 2 of the Gear Joint 2 ❷ and Slider Cam ❸.
- 2) Align the Gear FL Cam ❹ with the Gear Worm Wheel Post as shown detail drawing. (Refer to Timing Point 3)

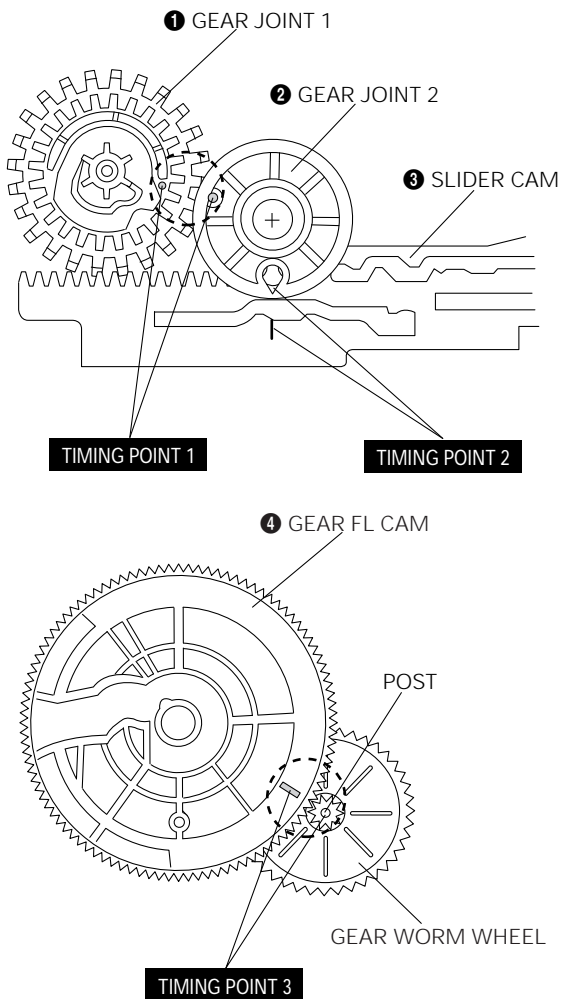

Fig. 1-10 Assembly of Gear FL Cam, Gear Joint 1,2

### 1-2-8 Holder Worm, Gear Worm, Gear Worm Wheel Removal

- 1) Release the Hook [A] in the direction of arrow and, remove the Holder Worm ❶.
- 2) Remove the Gear Worm ❷.
- 3) Remove the Gear Worm Wheel ❸. (After removing the Gear FL Cam as shown Fig. 1-9)

**Note :** Secure the Hook [A] after installing the Holder Worm ❶.

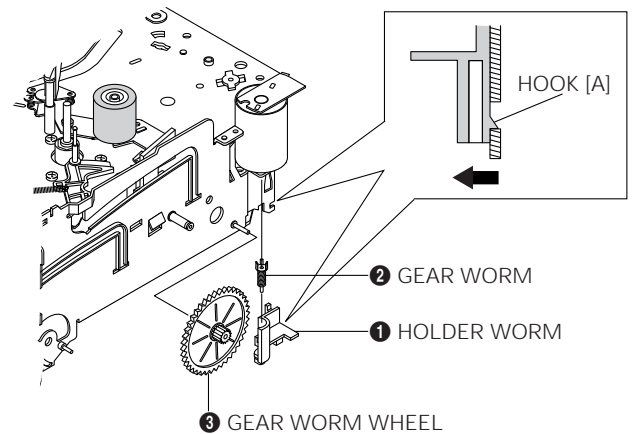

Fig. 1-11 Holder Worm, Gear Worm, Gear Worm Wheel Removal

### 1-2-9 Motor Loading Ass'y Removal

- 1) Remove the screw ❶.
- 2) Remove the Motor Loading Ass'y ❷.

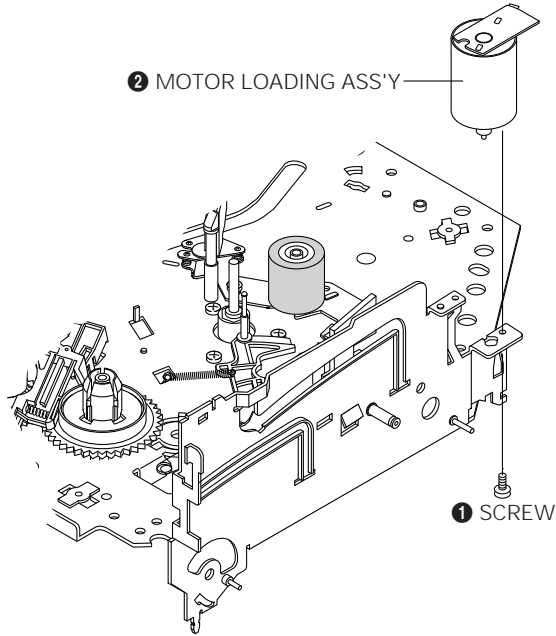

Fig. 1-12 Motor Loading Ass'y Removal

### 1-2-10 Gear Loading Drive, Slider Cam, Lever T, S Load Ass'y Removal

- 1) Remove the Belt Pulley. (Refer to Fig. 1-29)
- 2) Remove the Gear Loading Drive ❶ after releasing Hook [A] in the direction arrow as shown in detail drawing.
- 3) Remove the Slider Cam ❷.
- 4) Remove the Lever T, S Load Ass'y ❸, ❹.

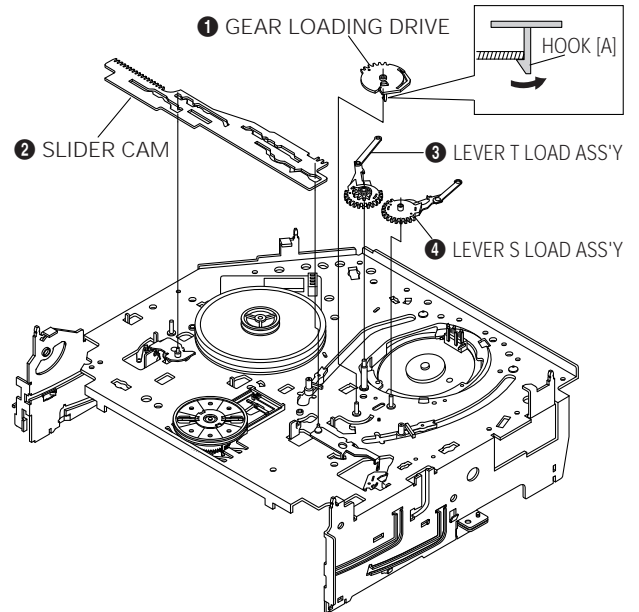

Fig. 1-13 Gear Loading Drive, Slider Cam, Lever T, S Load Ass'y Removal

### 1-2-11 Assembly of Gear Loading Drive, Slider Cam, Lever T, S Load Ass'y

- 1) When reinstalling, be sure to align dot of Lever T Load Ass'y ❶ with dot of Lever S Load Ass'y ❷ as shown in drawing. (Refer to Timing Point 1)
- 2) Insert the Pin A, B, C, D into the Slider Cam ❸ hole.
- 3) Be sure to align dot of Lever T Load Ass'y and dot of Gear Loading Drive ❹. (Refer to Timing Point 2)
- 4) Align dot of Gear Loading Drive with mark of Slider Cam as shown in drawing. (Refer to Timing Point 3)

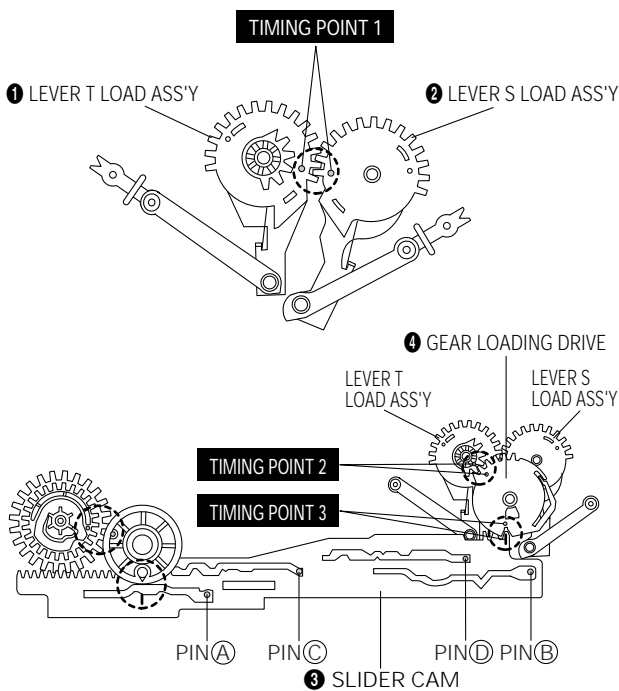

Fig. 1-14 Assembly of Gear Loading Drive, Slider Cam, Lever T, S Load Ass'y

### 1-2-12 Lever Tension Ass'y, Band Brake Ass'y, Sleeve Tension Removal

- 1) Remove the Spring Tension ❶.
- 2) In bottom side of Deck, remove the Sleeve Tension ❷ after rotating it right or left as lifting locking edge of Sleeve Tension.
- 3) Remove the side "a" of the Band Brake Ass'y ❹ in the direction of arrow "A" from the Lever Tension Ass'y ❸.
- 4) Remove the side "b" of the Band Brake Ass'y ❹ in the direction of arrow "B" from the Main Base.

**Note :**

- 1) When replacing the Lever Tension Ass'y, be sure to apply oil in the Sleeve Tension.
- 2) Take care not to touch stain on the felt side, and not to be folded and broken Band Brake Ass'y.

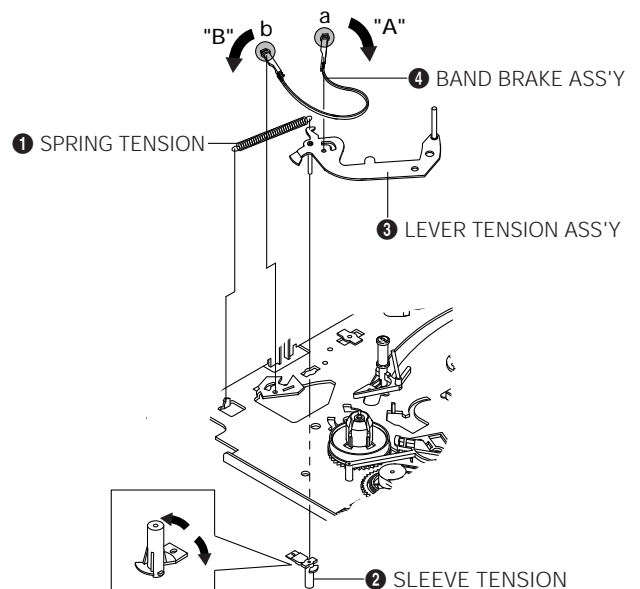

Fig. 1-15 Lever Tension Ass'y, Band Brake Ass'y, Sleeve Tension Removal

### 1-2-13 Lever S, T Brake Ass'y Removal

- 1) Release the Hook [A] and the Hook [B], [C] in the direction of arrow as shown in Fig. 1-16.
- 2) Lift the Lever S, T Brake Ass'y ❶, ❷ with Spring Brake ❸.

**Assembly :**

- 1) Assembly the Lever S Brake Ass'y ❶ on the Main Base.
- 2) Assembly the Lever T Brake Ass'y ❷ with Spring Brake ❸.

**Note :** Take extreme care not to be folded and transformed spring Brake at removing or reinstalling.

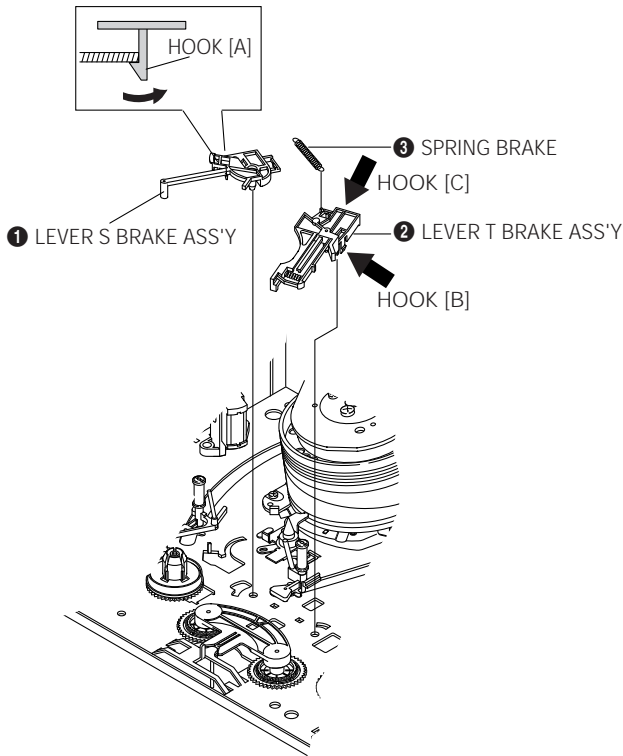

Fig. 1-16 Lever S, T Brake Ass'y Removal

### 1-2-14 Lever Idle Ass'y Removal

- 1) Push the Lever Idle ❶ in the direction of arrow "A", "B".
- 2) Lift the Lever Idle ❶.

**Assembly :**

- 1) Apply oil in two Bosses of Lever Idle ❶.
- 2) Assemble the Gear Idle ❷ with the Lever Idle ❶.

**Note :** When replacing the Gear Idle ❷, be sure to add oil in the boss of Lever Idle ❶.

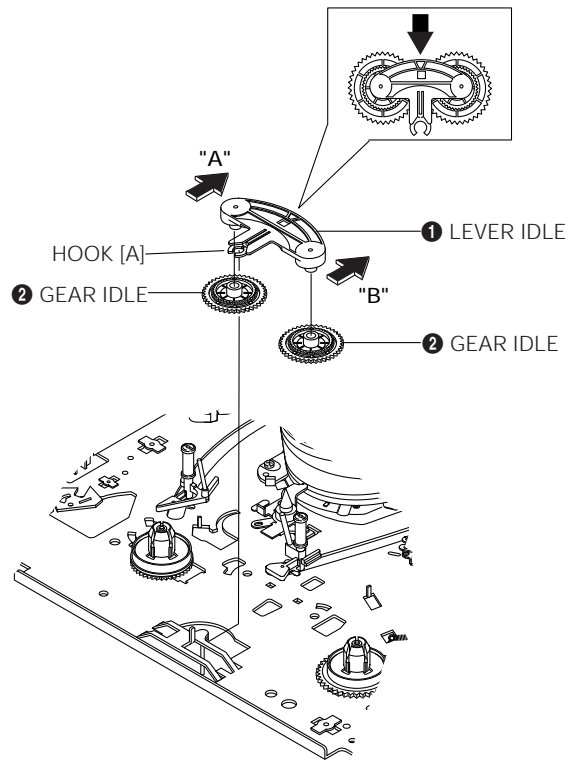

Fig. 1-17 Lever Idle Ass'y Removal

### 1-2-15 Disk S, T Reel Removal

- 1) Lift the Disk S, T Reel ❶, ❷.

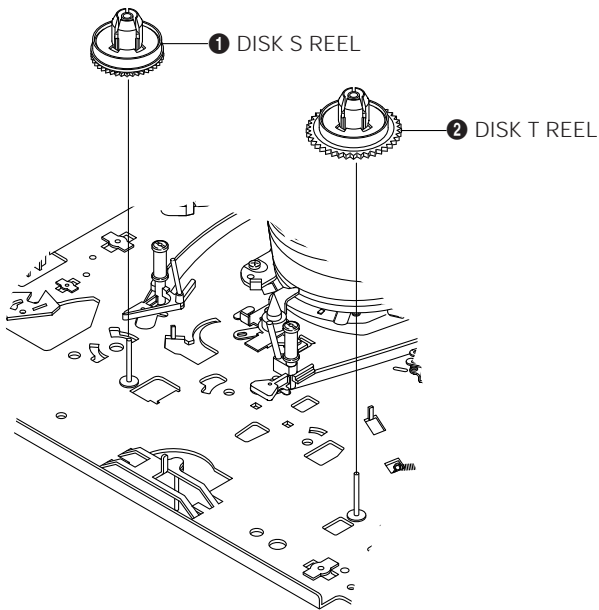

Fig. 1-18 Disk S, T Reel Removal

### 1-2-16 Holder Clutch Ass'y Removal

- 1) Remove the Washer Slit ❶.
- 2) Lift the Holder Clutch Ass'y ❷.

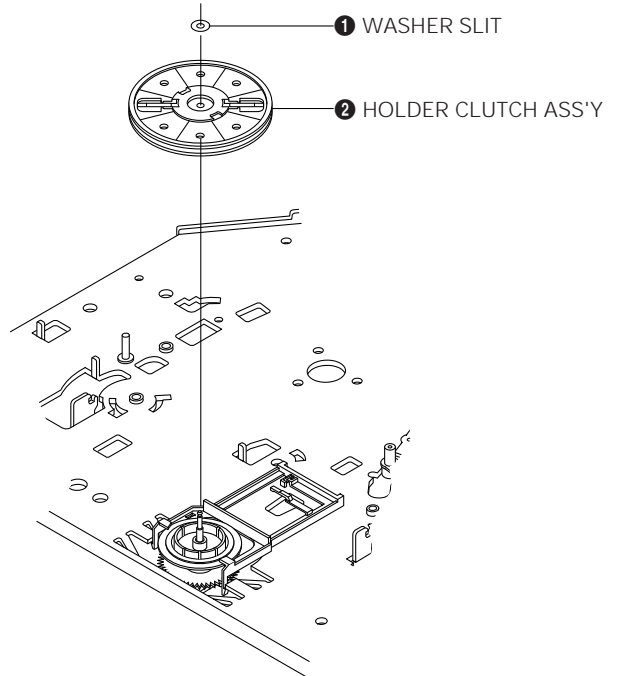

Fig. 1-19 Holder Clutch Ass'y Removal

### 1-2-17 Lever Up Down Ass'y, Gear Center Ass'y Removal

- 1) Remove the 2 hooks in the direction of arrow as shown Fig. 1-20 and lift the Lever Up Down Ass'y ①.
- 2) Lift the Gear Center Ass'y ②.

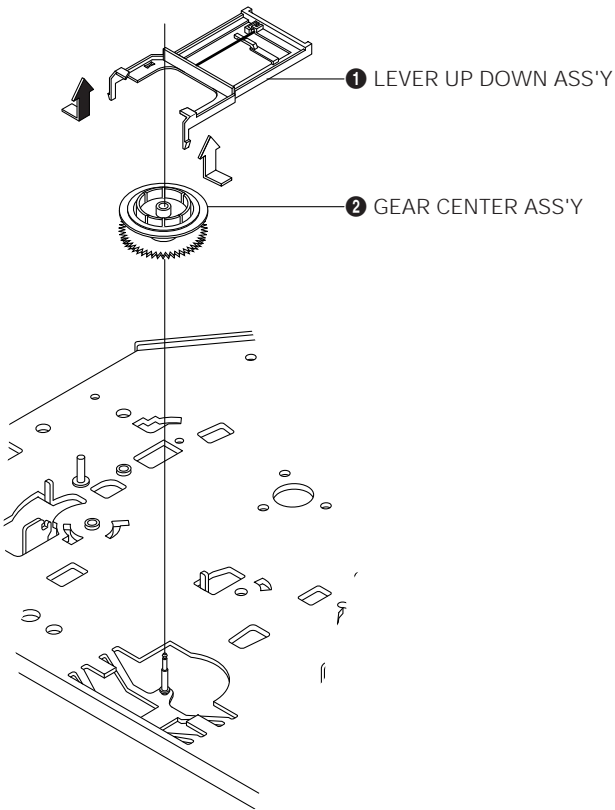

Fig. 1-20 Lever Up Down Ass'y, Gear Center Ass'y Removal

### 1-2-18 Assembly of Lever Up Down Ass'y, Gear Center Ass'y

- 1) Insert the Lever Up Down Ass'y ① in the 2 rectangular holes on Main Base.
- 2) Lift the Lever Up Down Ass'y ① about 35 degree. (Refer to Fig. 1-21)
- 3) Insert Ring ④ of the Gear Center Ass'y ② in the Guide ⑤ of the Lever Up Down Ass'y ①.
- 4) Insert the Gear Center Ass'y ② in the post ⑥ on Main Base.
- 5) Push down the Lever Up Down Ass'y ① for locking of the Hook ⑦.

**Note :**

- 1) Take care not to separate and loose the Spring Up Down.
- 2) When assembling the Gear Center Ass'y, don't push down too much.

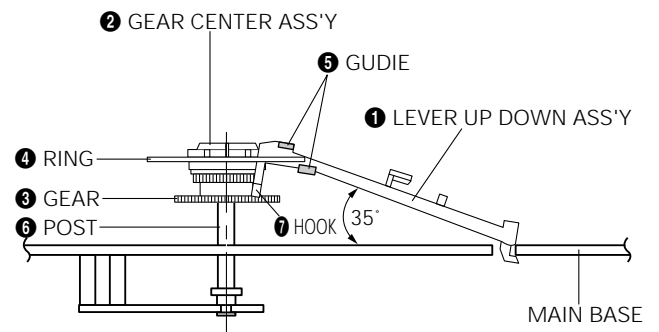

Fig. 1-21 Assembly of Lever Up Down Ass'y, Gear Center Ass'y

### 1-2-19 Guide Cassette Door Removal

- 1) Lift the Hook [A].
- 2) Rotate the Guide Cassette Door ❶ in the direction of arrow.

**Note :** After reinstalling the Guide Cassette Door ❶ secure the Hook [A].

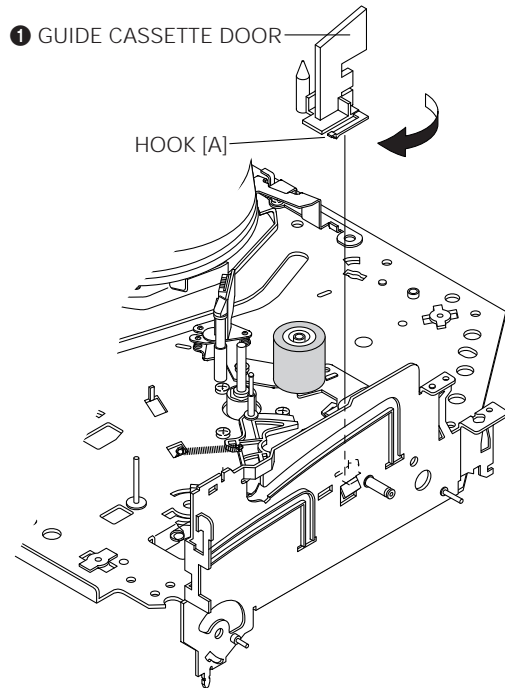

Fig. 1-22 Guide Cassette Door Removal

### 1-2-20 Unit Pinch Ass'y, Plate Joint, Spring Pinch Drive Removal

- 1) Lift the Unit Pinch Ass'y ❶.
- 2) Remove the Plate Joint ❷ from Lever Pinch Drive.
- 3) Remove the Spring Pinch Drive ❸.

**Note :**

- 1) Take extreme care not to touch the grease on the Roller Pinch.
- 2) When reinstalling, be sure to apply grease on the post pinch roller.

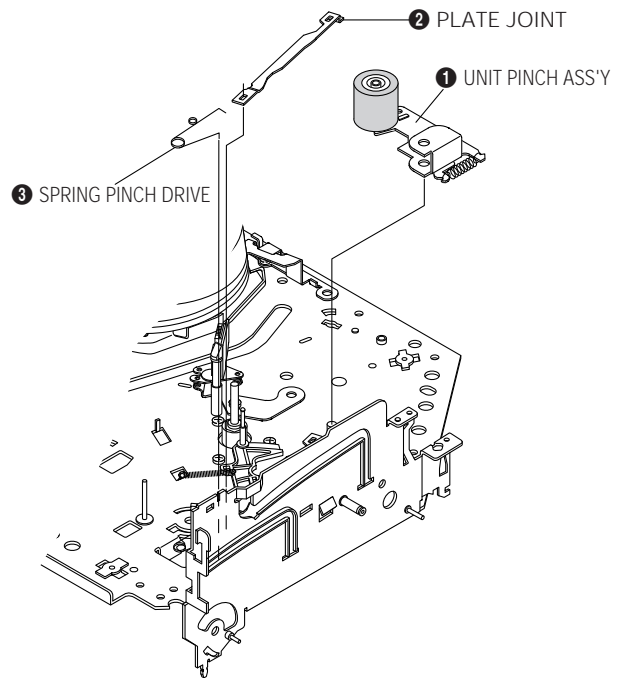

Fig. 1-23 Unit Pinch Ass'y, Plate Joint, Spring Pinch Drive Removal

### 1-2-21 Lever #9 Guide Ass'y Removal

- 1) Remove the Spring #9 Guide ❶.
- 2) Lift the Lever #9 Guide Ass'y ❷ in the direction of arrow.

**Note :**

- 1) Take extreme care not to touch the grease on the tape Guide Post.
- 2) After reinstalling, check the bottom side of the Post #9 Guide to stick to the top side of Main Base.

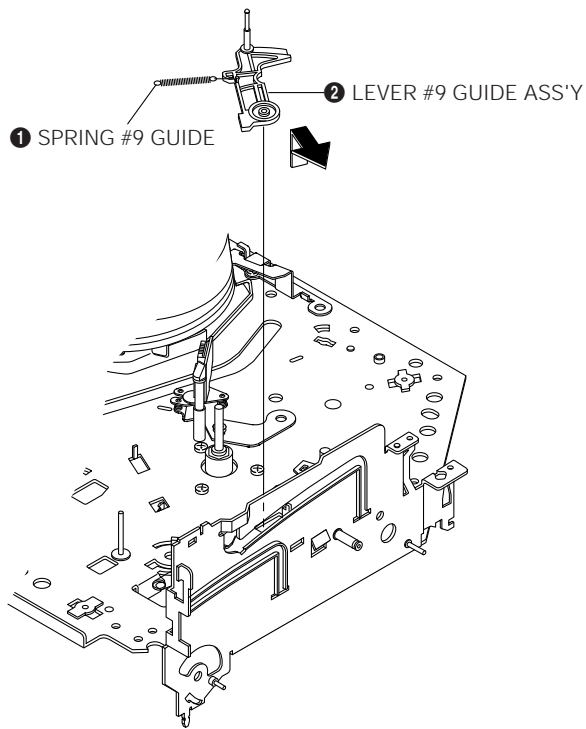

Fig. 1-24 Lever #9 Guide Ass'y Removal

### 1-2-22 FE Head Removal

- 1) Remove the screw ❶.
- 2) Lift the FE Head ❷.

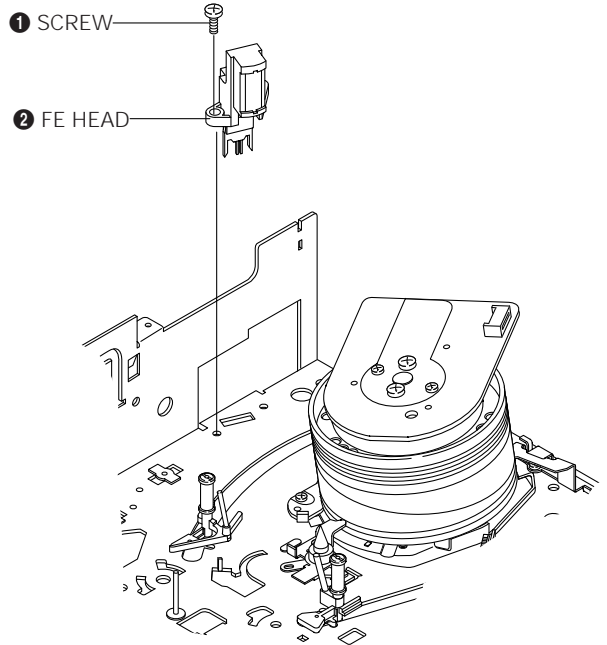

Fig. 1-25 FE Head Removal

### 1-2-23 ACE Head Removal

- 1) Pull out the FPC from connector of ACE Head Ass'y ②.
- 2) Remove the screw ①.
- 3) Lift the ACE Head Ass'y ②.

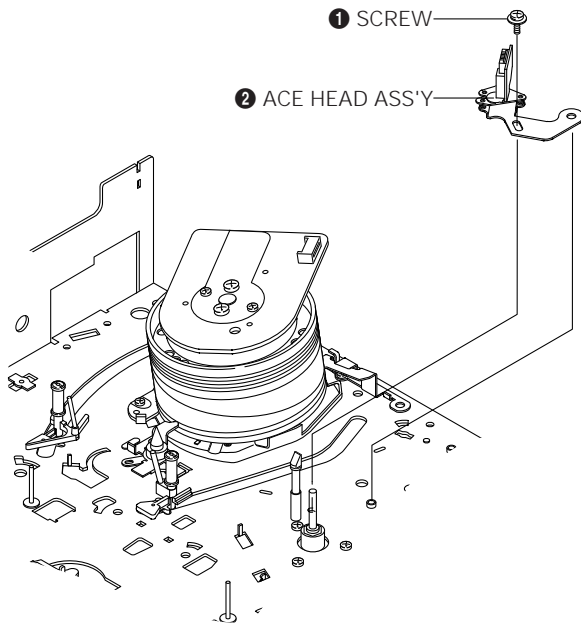

Fig. 1-26 ACE Head Removal

### 1-2-24 Slider S, T Ass'y Removal

- 1) Move the Slider S, T Ass'y ①, ② to slot, and then lift it to remove. (Refer to arrow)

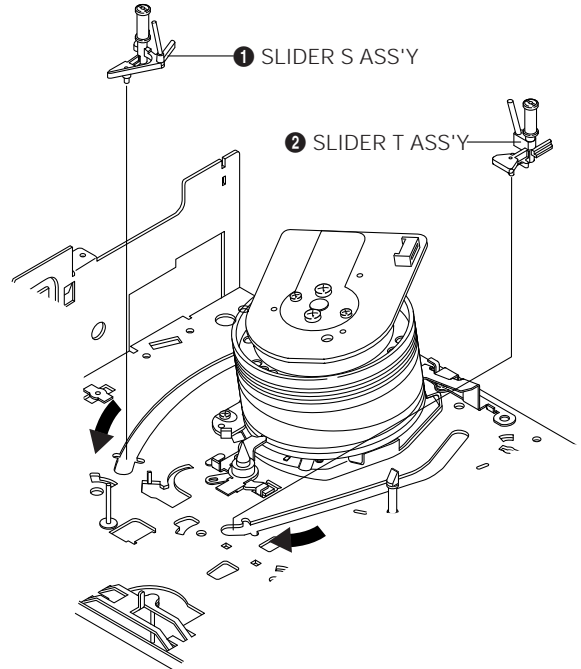

Fig. 1-27 Slider S, T Ass'y Removal

### 1-2-25 Cylinder Ass'y Removal

- 1) Remove the 3 Screws ❶, ❸, ❺.
- 2) Remove the Plate Cylinder A, B, C ❷, ❹, ❻ in the direction of arrow.
- 3) Lift the Cylinder Ass'y ❽.

**Note :**

- 1) When reinstalling, push the Plate Cylinder A, B ❹, ❻ in the reverse of arrow and then, tighten the 2 Screws ❸, ❺.
- 2) Take care not to touch the Cylinder Ass'y and the tape guide post at reinstalling Plate Cylinder C ❷.
- 3) Take care not to touch the Cylinder Ass'y with screw driver at reinstalling the Plate Cylinder C ❷.

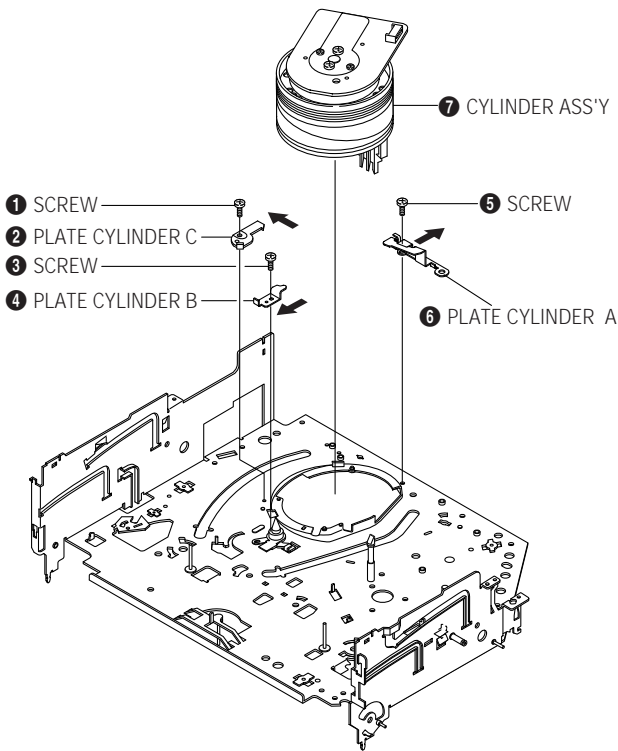

Fig. 1-28 Cylinder Ass'y Removal

### 1-2-26 Belt Pulley Removal

- 1) Remove the Belt Pulley ❶.

**Note :** Take extreme care not to touch the grease on Belt Pulley ❶ at assembling or reassembling.

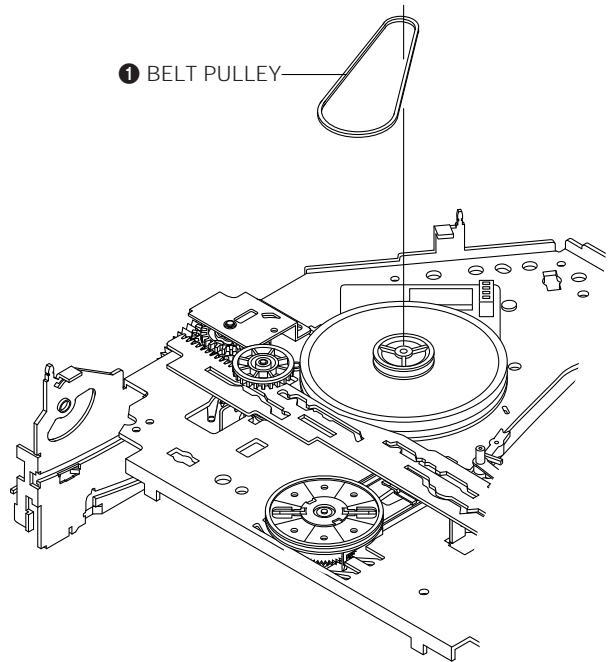

Fig. 1-29 Belt Pulley Removal

### 1-2-27 Lever Head Cleaner Ass'y Removal (Optional)

- 1) Release the Hook ❶.
- 2) Lift the Lever Head Cleaner Ass'y ❷.

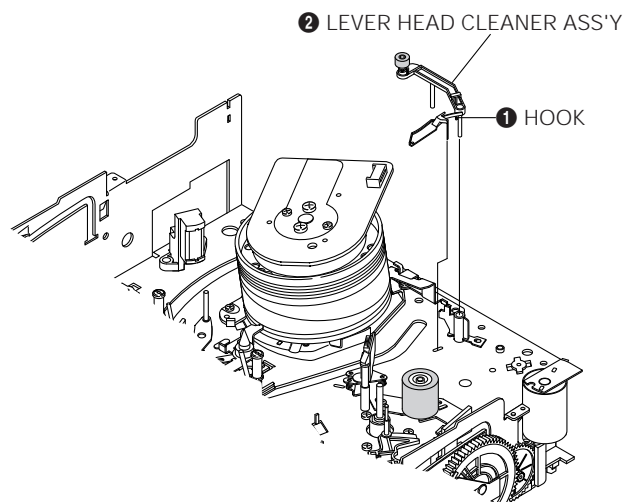

Fig. 1-30 Lever Head Cleaner Ass'y Removal

### 1-2-28 Motor Capstan Ass'y Removal

- 1) Remove the 3 Screws ❶.
- 2) Remove the Motor Capstan Ass'y ❷.

**Assembly :**

- 1) Match the 3 holes of Motor Capstan Ass'y ❷ to the 3 holes of Main Base as attending not to drop or knock the Motor Capstan Ass'y.
- 2) Tighten the 3 Screws in the direction of arrow as shown detail drawing.

**Note :**

- 1) Don't reuse the removed screws from Motor Capstan Ass'y.
- 2) After tightening screws, check if there is gap between the head of screws and the top side of Main Base. There should have no gap between the head of screws and the top side of Main Base.
- 3) After reinstalling, adjusting the tape transport system again.

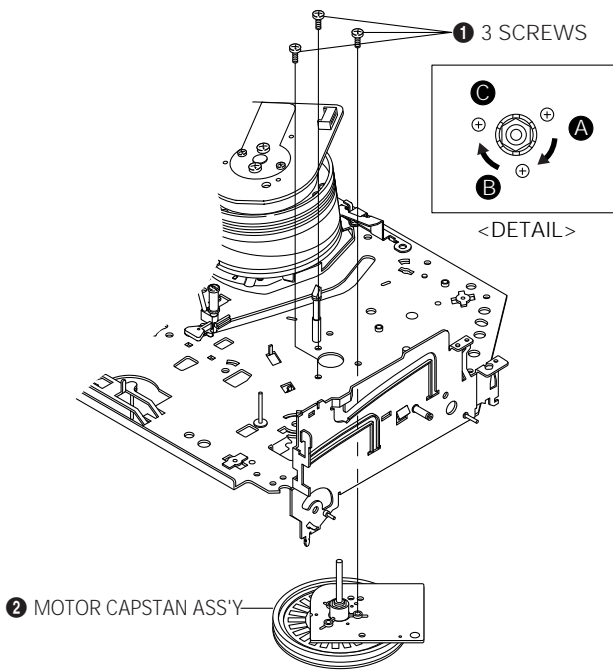

Fig. 1-31 Motor Capstan Ass'y Removal

### 1-2-29 How to Eject the Cassette Tape (If the unit does not operate on condition that is inserted into housing ass'y)

- 1) Remove the Holder worm ❶ and the Gear Worm ❷.
- 2) Turn the Gear Worm Wheel ❸ counterclockwise with screw driver. (Refer to arrow)

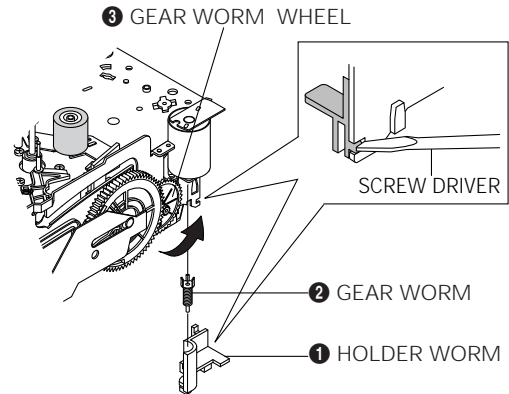

Fig. 1-32

- 3) When Slider S, T are approached in the position of unloading, rotate holder Clutch counterclockwise after inserting screw driver in the hole of frame's bottom in order to wind the unwound tape. (Refer to Fig. 1-33)  
(If you rotate Gear Worm Wheel continuously when tape is in state of unwinding, you may cause a tape contamination by grease and tape damage. Be sure to wind the unwound tape in the state of set horizontally.)
- 4) Rotate Gear Worm Wheel ❸ counterclockwise using screw driver again up to the state of eject mode and then pick out the tape. (Refer to Fig. 1-32)

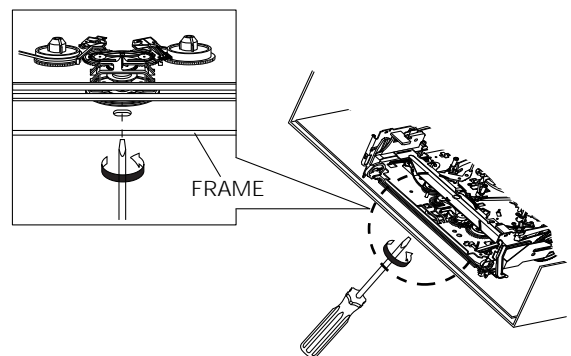

Fig. 1-33

### 1-3 The table of clearing, Lubrication and replacement time about principal parts

- 1) The replacement time of parts is not life of parts.
- 2) The table 1-1 is that the VCR Set is in normal condition (normal temperature, normal humidity).  
The checking period may be changed owing to the condition of use, runtime and environmental conditions.
- 3) Life of the Cylinder Ass'y is depend on the condition of use.
- 4) See exploded view for location of each parts.

<Table 1-1>

*	Parts Name	Checking Period										Remark
		500	1000	1500	2000	2500	3000	3500	4000	4500	5000	
T A P E  P A T H  S Y S T E M	POST TENSION	Δ	Δ	Δ	Δ	Δ	Δ	Δ	Δ	Δ	Δ	- To clean the parts, use patch and alcohol (solvent).  - After cleaning, use the video tape after alcohol is gone away completely.  - We recommend to use oil [EP-56] or solvent.  - One or two drops of oil should be applied after cleaning with alcohol.  - Periodic time of applying oil (Apply oil after cleaning) - The excessive applying oil may be the cause of malfunction.
	SLANT POST S, T	Δ	Δ	Δ	Δ	Δ	Δ	Δ	Δ	Δ	Δ	
	#8 GUIDE SHAFT	Δ	Δ	Δ	Δ	Δ	Δ	Δ	Δ	Δ	Δ	
	CAPSTAN SHAFT	Δ	Δ	Δ	Δ	Δ	Δ	Δ	Δ	Δ	Δ	
	#9 GUIDE POST	Δ	Δ	Δ	Δ	Δ	Δ	Δ	Δ	Δ	Δ	
	#3 GUIDE POST	Δ	Δ	Δ	Δ	Δ	Δ	Δ	Δ	Δ	Δ	
	GUIDE ROLLER S, T	Δ	Δ	Δ	○	○	○	○	○	○	○	
	CYLINDER ASS'Y	Δ	○	○	○	○	○	○	○	○	○	
	FE HEAD	Δ	Δ	Δ	○	○	○	○	○	○	○	
	ACE HEAD	Δ	○	○	○	○	○	○	○	○	○	
	PINCH ROLLER	Δ	○	○	○	○	○	○	○	○	○	
	POST REEL S, T		◆		◆		◆		◆		◆	
	SLEEVE TENSION		◆		◆		◆		◆		◆	
	POST CENTER		◆		◆		◆		◆		◆	
LEVER IDLE BOSS (2Point)		◆		◆		◆		◆		◆		
D R I V I N G  S Y S T E M	CAPSTAN MOTOR PULLEY	Δ	Δ	Δ	Δ	Δ	○	○	○	○	○	
	BELT PULLEY				○	○	○	○	○	○	○	
	HOLDER CLUTCH ASS'Y	Δ	○	○	○	○	○	○	○	○	○	
	GEAR CENTER ASS'Y		○	○	○	○	○	○	○	○	○	
	GEAR IDLE (2Point)		○	○	○	○	○	○	○	○	○	
	LOADING MOTOR		○	○	○	○	○	○	○	○	○	
B R A K E  S Y S T E M	BAND BRAKE ASS'Y		○	○	○	○	○	○	○	○	○	
	BRAKE T ASS'Y		○	○	○	○	○	○	○	○	○	

Δ : Cleaning      ○ : Check and replacement in necessary      ◆ : Add Oil

## 2. Alignment and Adjustment

### 2-1 Tape Transport System and Adjustment Locations

The tape transport system has been adjusted precisely in the factory. Alignment is not necessary except for the following :

- 1) Noise observed on the screen.
- 2) Tape damage.
- 3) Parts replacement in the tape transport system.

Lower flange height of tape guide is used as the reference for the transport adjustment.

To maintain the height of the tape guide and prevent damage, do not apply excessive force onto the main base.

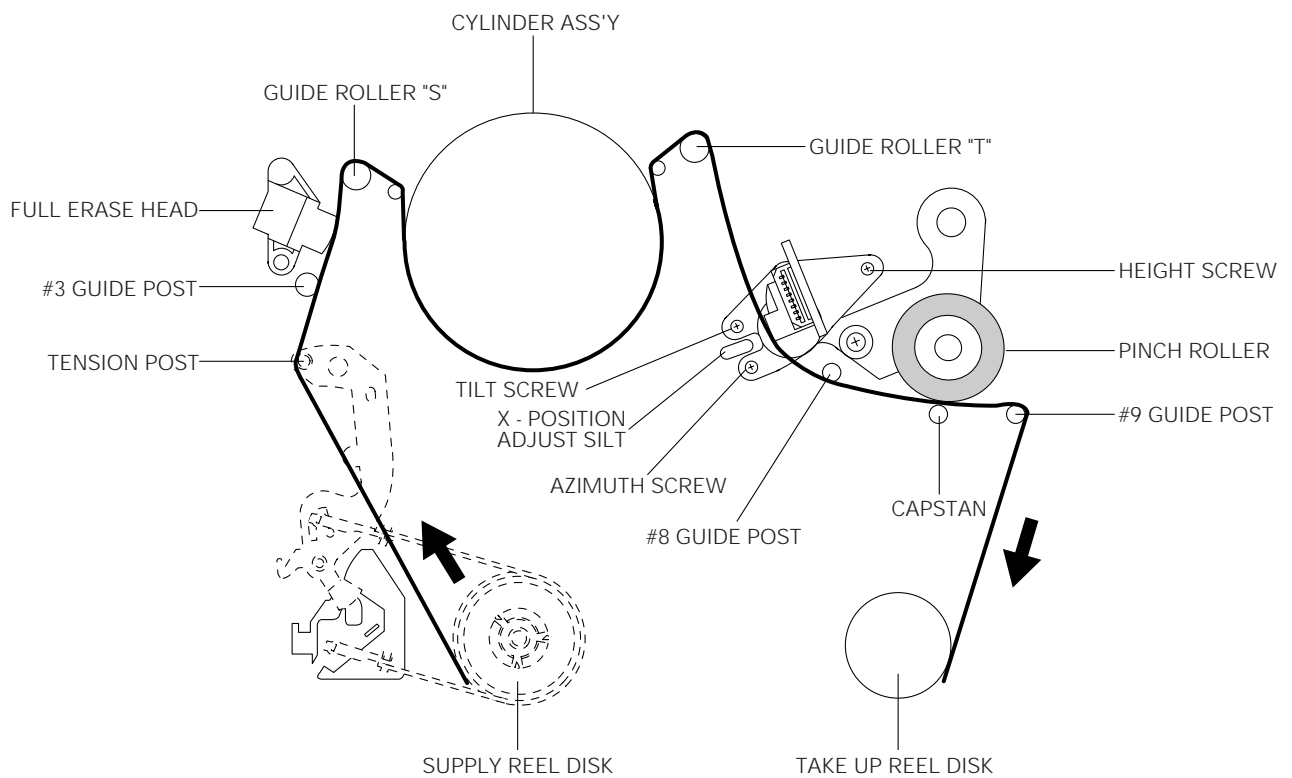

Fig. 2-1 Location of Tape Transport Adjustment

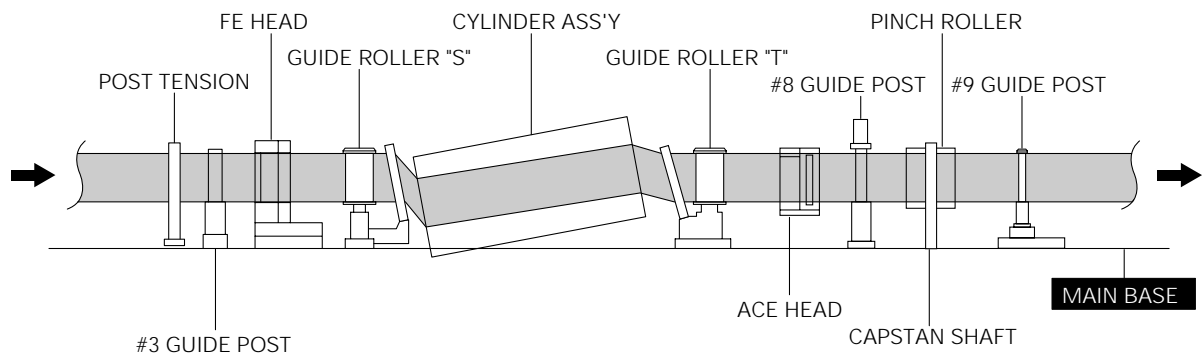

Fig. 2-2 Tape Travel Diagram

## 2-2 Tape Transport System Adjustment

When parts are replaced, perform the required adjustments by referring to procedures for the tape transport system. If there are any changes to the tape path, first run a T-120 tape and make sure excessive tape wrinkle does not occur at the tape guides.

- 1) If tape wrinkle is observed at the guide roller S, T, turn the guide roller S, T until wrinkle disappears.
- 2) If the tape wrinkle is still observed at the tape guide, perform the tilt adjustment of the ACE head. (See page 5-3 of the Service Manual for Test Point Locations.)

### 2-2-1 ACE Head Assembly Adjustment

#### 2-2-1(a) ACE HEAD HEIGHT ADJUSTMENT

- 1) Run the alignment tape (Color bar) in the playback mode.
- 2) Observe surface of the audio head using a dental mirror.
- 3) Turn screw (C) clockwise or counterclockwise until the gap of lower tape edge and the lower edge of the control head is about 0.25mm. (Refer to Fig. 2-3 and 2-4)

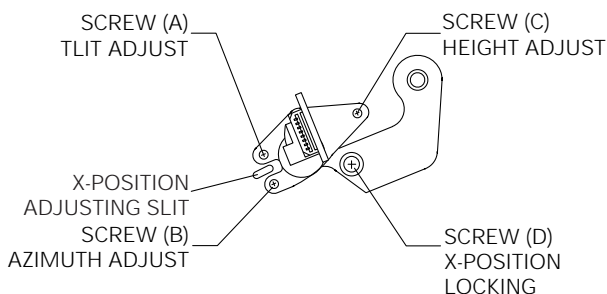

Fig. 2-3 Location of ACE Head Adjustment Screw

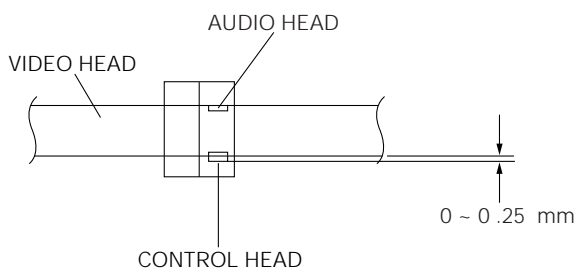

Fig. 2-4 ACE Head Height Adjustment

#### 2-2-1(b) ACE HEAD TILT ADJUSTMENT

- 1) Playback a blank tape and observe the position of the tape at the lower flange of tape guide.
- 2) Confirm that there is no curl or wrinkle at the lower flange of tape guide as shown in Fig. 2-5 (B).
- 3) If a curl or wrinkle of the tape occurs, slightly turn the screw (A) tilt adjust on the ACE head ass'y.
- 4) Reconfirm the ACE head height.

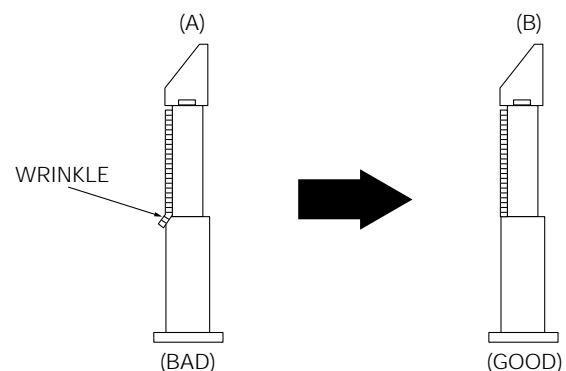

Fig. 2-5 Tape Guide Check

#### 2-2-1(c) AUDIO AZIMUTH ADJUSTMENT

- 1) Load alignment tape (Mono scope) and playback the NTSC : 7KHz (PAL : 6KHz) signal.
- 2) Connect channel-1 scope probe to audio output test point.
- 3) Adjust screw (B) to achieve maximum audio level. (See Fig. 2-3)

#### 2-2-1(d) ACE HEAD POSITION (X-POINT) ADJUSTMENT

- 1) See page 5-1 of the Service Manual for ACE Head position (X-Point) adjustment.

### 2-2-2 Linearity adjustment (Guide roller S, T adjustment)

- 1) Playback the Mono Scope alignment tape (SP mode).
- 2) Observe the video envelope signal on an oscilloscope (triggered by the video switching pulse).
- 3) Make sure the video envelope waveform (at its minimum) meets the specification shown in Fig. 2-6.  
If it does not, adjust as follows :

**Note :**

- a=Maximum output of the video RF envelope.
- b=Minimum output of the video RF envelope at the entrance side.
- c=Minimum output of the video RF envelope at the center point.
- d=Maximum output of the video RF envelope at the exit side.

- 4) If the section A in Fig. 2-7 does not meet the specification, adjust the guide roller S up or down.
- 5) If the section B in Fig. 2-7 does not meet the specification, adjust the guide roller T up or down.

- 6) Play back the Mono Scope alignment tape (SP mode).
- 7) Connect an oscilloscope CH-1 to the Envelope and CH-2 to the H'D SW Pulse for triggering.
- 8) Turn the guide roller heads with a flat head (  ) driver to obtain a flat video RF envelope as shown in Fig. 2-8.

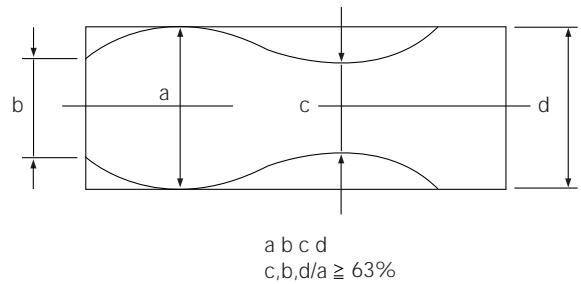

Fig. 2-6 Envelope Waveform Adjustment

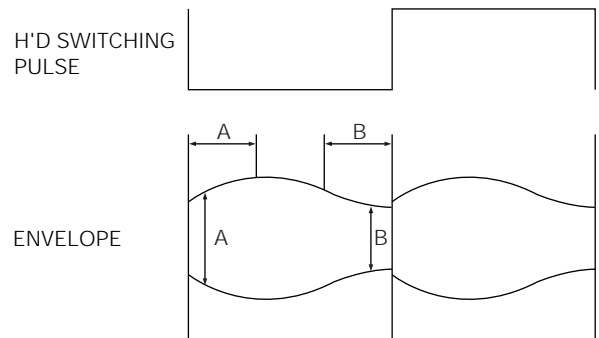

Fig. 2-7 Adjustment Points

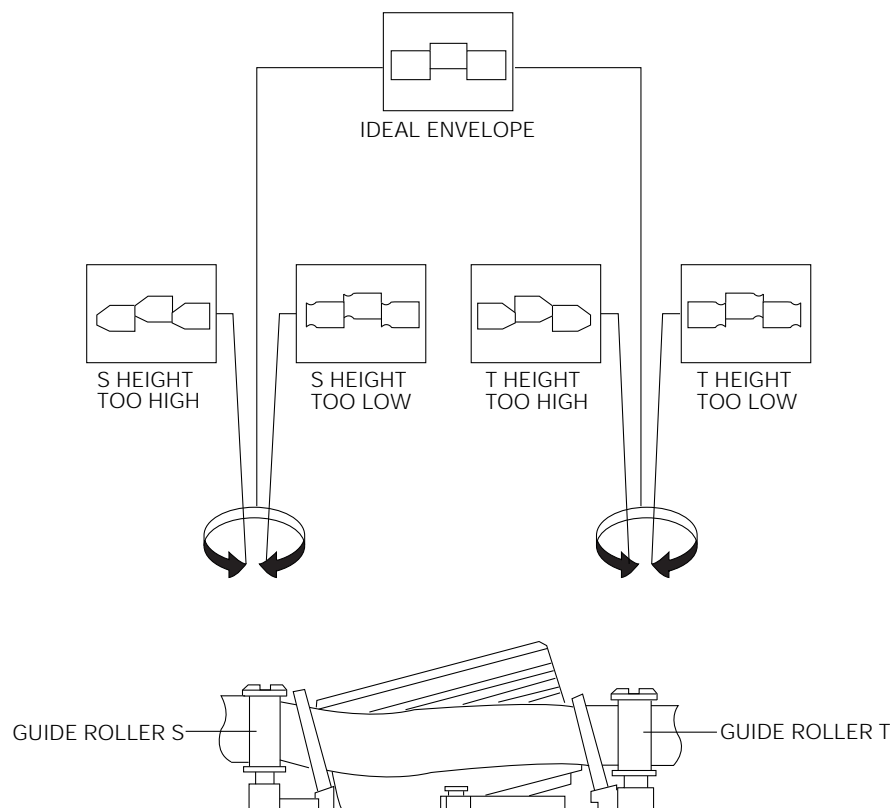

Fig. 2-8 Guide Roller S, T Height Adjustment

### 2-2-3 Check Transitional Operation from RPS to Play

Check transition from RPS mode to play mode :  
 Using a pre-recorded SP tape, make sure the entry side of envelope comes to an appropriate steady state within 3 seconds (as shown in Fig. 2-9).  
 If the envelope waveform does not reach specified peak-to-peak amplitude within 3 seconds, adjust as follows :

- 1) Make sure there is no gap between the supply roller lower flange and the tape.  
 If there is a gap, adjust the supply guide roller again.
- 2) Change operation mode from the RPS to the play mode (again) and make sure the entry side of envelope rises within 3 second.

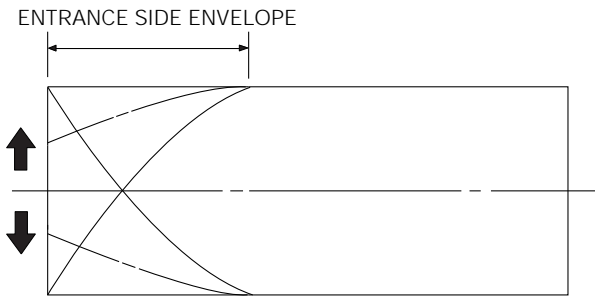

Fig. 2-9 Video Envelope Rising when Operation mode Changes from RPS to Play Mode

### 2-2-4 Envelope Check

- 1) Make recordings on T-120 (E-120) and T-160 (E-180) tape.  
 Make sure the playback output envelope meets the specification as shown in Fig. 2-10.
- 2) Play back a self recorded tape (recording made on the unit using with T-120 (E-120)).  
 The video envelope should meet the specification as shown in Fig. 2-10.  
 In SP mode, (A) should equal (B).  
 If the head gap is wide, upper cylinder should be checked.

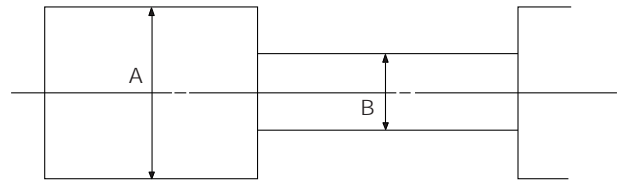

Fig. 2-10 Envelope Output and Output Level

### 2-2-5 Tape Wrinkle Check

- 1) Run the T-160 (E-180) tape in the playback, FPS, RPS and Pause modes and observe tape wrinkle at each guide.
- 2) If excessive tape wrinkle is observed, perform the following adjustments in Playback mode :
  - ◆ Tape wrinkle at the guide roller S, T section :  
Linearity adjustment.
  - ◆ Tape wrinkle at tape guide flange :  
ACE head assembly coarse adjustment.

## 2-3 Reel Torque

- 1) The rotation of the capstan motor causes the Holder Clutch Ass'y to rotate through the Belt Pulley.
- 2) The spring wrap PLAY/REV of holder clutch ass'y drives the disk reel S, T through gear idle by rotation of gear center ass'y.
- 3) Brake is operated by slider cam at FF/REW mode.
- 4) Transportation of accurate driving force is done by gears. (Gear Center Ass'y)

**Note :** If the spec. does not meet the followings specifications, replace the holder clutch ass'y and then recheck.

<Table 2-1>

MODE	TORQUE g/cm		GAUGE
PB	NTSC	82.5 ± 27.5	Cassette Torquemeter
	PAL	79 ± 27	
RPS	145 ± 30		Cassette Torquemeter

## 2-4 Location adjustment and Confirmation of Tension Post

- 1) Remove the holder cassette ass'y and then push the lever FL Arm-R to the direction of loading.
- 2) Push the lever tension drive ❶ in the direction of arrow. (See Fig. 2-11)
- 3) Turn the gear worm wheel ❷ clockwise so that "Timing Point" of the slider FL drive ❸ and gear FL cam ❹ can be aligned (See Fig. 2-12)

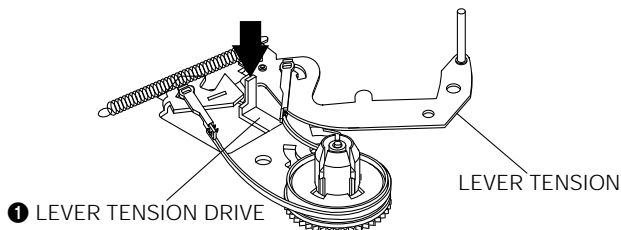

Fig. 2-11

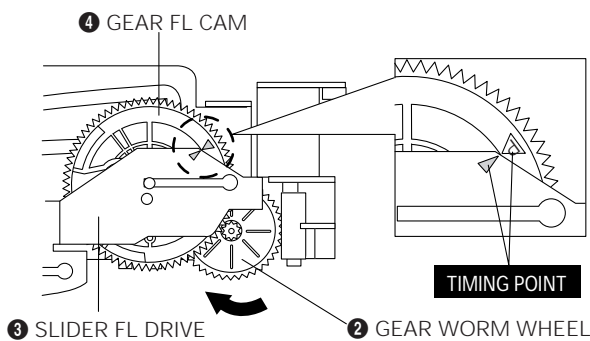

Fig. 2-12

- 4) As rotating Disk S Reel ❶ clockwise and the region of adjusting in the Main Base (in shape of slit) clockwise or counterclockwise after inserting screw driver in the slit on Main Base. Adjust the left end edge of Lever Tension Ass'y ❸ to  $1.3 \pm 1.5 / -0.5\text{mm}$  from the location of mark in the Main Base.
- 5) As rotating Disk S Reel ❶, double-check the location of the left end edge of Lever Tension Ass'y and the quantity of crossing from mark on Main Base. ( $+1.0 / -0.5\text{mm}$ )

**Counterclockwise** : Torque UP

**Clockwise** : Torque DOWN

Back Tension should be  $56 \pm 15\text{g.cm}$  at inspecting it with Back Tension Meter.

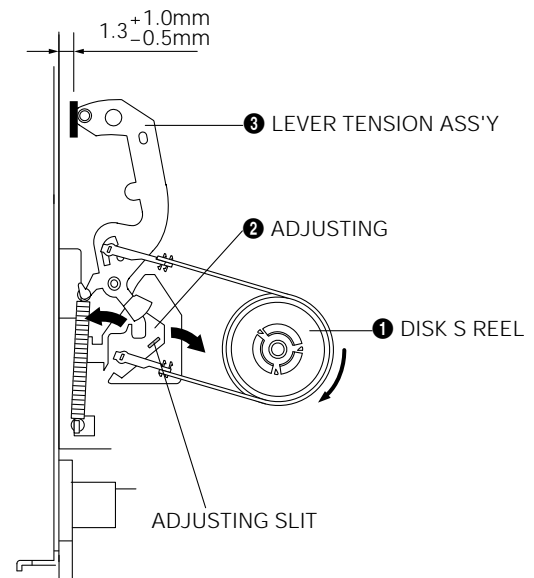

Fig. 2-13 Tension Pole and Back Tension Adjustment

### Note :

- 1) Mark on Main Base is located in about 1.3mm from inside of bending line.
- 2) Be careful not to deform the region of adjusting on Main Base up and down at adjusting.

# MEMO