



WASHING MACHINE

SWF-P8IW/XEH

SWF-P10IW/XEH

SERVICE Manual

WASHING MACHINE

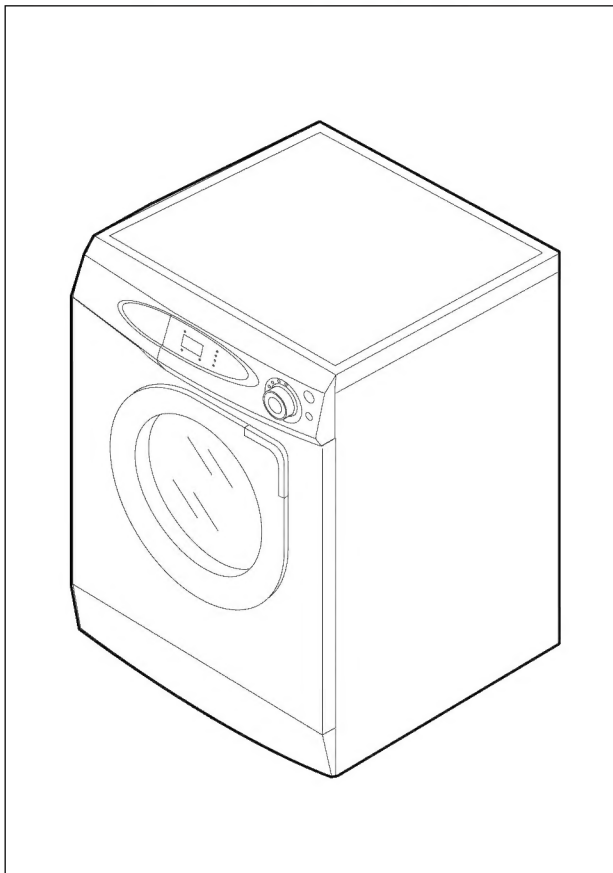

CONTENTS

1. SPECIFICATIONS
2. OVERVIEW OF THE WASHING MACHINE
3. OVERVIEW OF THE CONTROL PANEL
4. PROCESS TABLE
5. GENERAL REEOR FUNCTION
6. TROUBLE DIAGNOSIS
7. TEST MODE
8. DESIGNATION OF MAIN COMPONENTS
9. PCB SHEMATIC DIAGRAM
PCB CIRCUIT DIAGRAM
PCB PATTERN DIAGRAM
WIRING DIAGRAM
10. ASSEMBLE AND DISASSEMBLE
11. TOOLS FOR DISASSEMBLY AND ASSEMBLY
12. EXPLODED VIEW AND PARTS LIST



Caution for the safety during servicing

1. Do not allow the customer to repair the product.

☞ The person may be injured or the product life may be shortened.

2. Execute A/S after unplugging the power supply unit.

☞ Be care of the electric shock.

3. Do not plug several plugs in the same outlet.

☞ It may cause the fire due to overheat.

4. Check the damage, pressing or burning of the power plug or outlet.

☞ Replace it promptly if it has problem.(It may cause the electric shock or fire)

5. Do not clean the main body with the water.

☞ It may cause the electric shock and fire and shorten the product life)

6. The wiring of the harness shall be free from the moisture and tightened during serving.

☞ It shall not be deviated by certain impact.

7. Remove any dust or filth on the housing section,wiring section,connection section during servicing.

☞ Protect the cause of the fire such as the tracking,shortage and etc.

8. Check any mark of the moisture on the electrical parts, harness section and etc.

☞ Replace the parts or remove the moisture.

9. Check the assembly status of the parts after servicing.

☞ Maintain the status before servicing.

10. Pull out the power cord with holding the plug.

☞ Be care of the electric shock and fire when the cord is damaged.

11. Unplug the power plug from the outlet when the wash machine is not used.

☞ Be care of the electric shock and fire due to the strike of the lightening.

12. Do not use or store the spray or flammable materials(including gasoline,alcohol and etc.) around the wash machine.

☞ Be care of the explosion or fire due to the electric spark.

13. Do not put the bowl of water or wet laundry on the wash machine.

☞ If the water is penetrated to the wash machine, this may cause the electric shock or fire.

14. Do not install the wash machine in the place where the snow or rain falls.

☞ It may cause the electric shock and fire and shorten the product life.

15. Do not push the control buttons with the awl,pin, or sharp materials.

☞ It may the electric shock and trouble.

16. Check the wash machine is leveled horizontally and installed properly on the floor.

☞ The vibration may shorten the product life.

17. Joint the wire by the connector correctly.

☞ When the wire is jointed by the tape, this may cause the fire due to the tracking.

18. When the wash machine is to be laid for the service, put the pad on the floor and lay the product at side slowly.

☞ If the wash machine is laid front, the relay may be damaged by the tub.

19. When the wash-heater is replaced, check it is inserted in the bracket-heater and screw the nut.

☞ If the wash-heater is not inserted in the bracket-heater properly, this may cause the noise and leakage since it is contacted to the drum.

1. Specifications

WASH TYPE	FRONT LOADING TYPE				
DIMENSION	GROSS	W 669mm X D 656mm X H 910mm			
	NET	W 598mm X D 555mm X H 844mm			
WATER PRESSURE	50 kPa ~ 800 kPa				
WEIGHT	GROSS	80 kg			
	NET	75 kg			
WASH and SPIN CAPACITY	50 kg (DRY LAUNDRY)				
POWER CONSUMPTION	WASHING		220 V	180 W	
			240 V	180 W	
	WASHING and HEATING		220 V	2400 W	
			240 V	2800 W	
	SPIN	MODEL	SWF-P8	SWF-P10	SWF-P12
		220 V	430 W	500 W	550 W
		240 V	430 W	500 W	550 W
PUMPING		34 W			
WATER CONSUMPTION	54 (STANDARD COURSE)				
SPIN REVOLUTION	MODEL	SWF-P8	SWF-P10	SWF-P12	
	rpm	800	1000	1200	

2. Overview of the Washing Machine

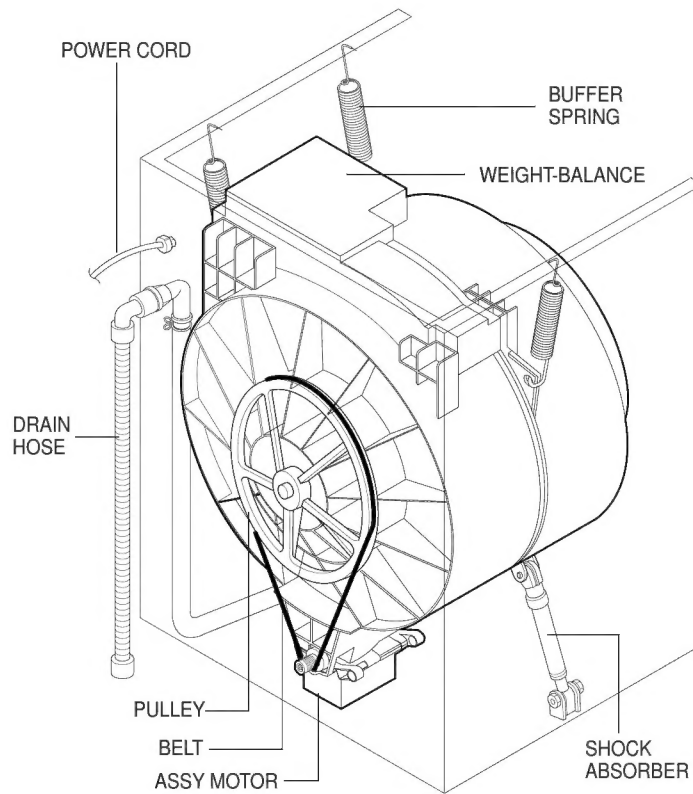
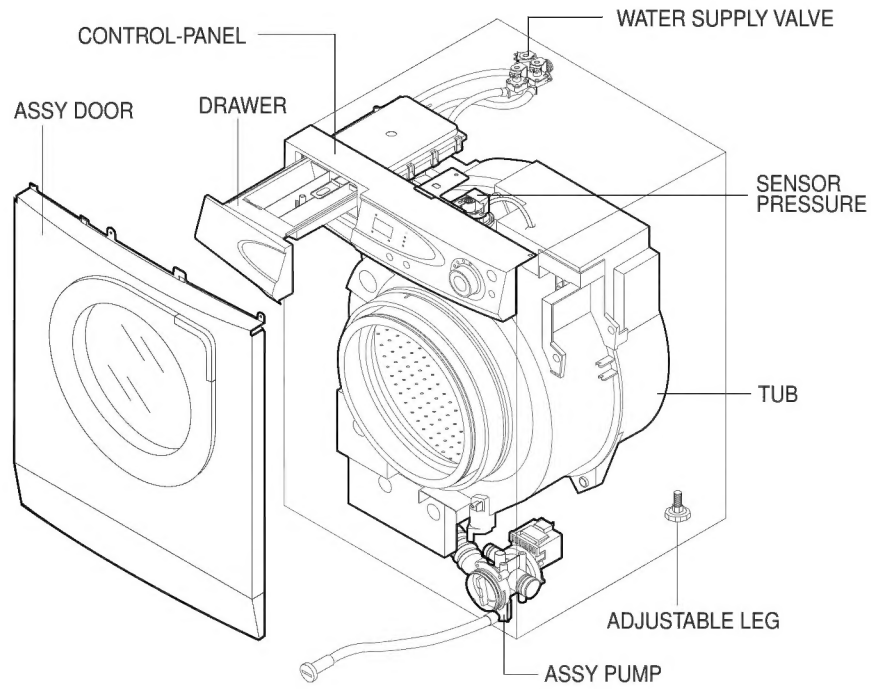

3. Overview of the control panel

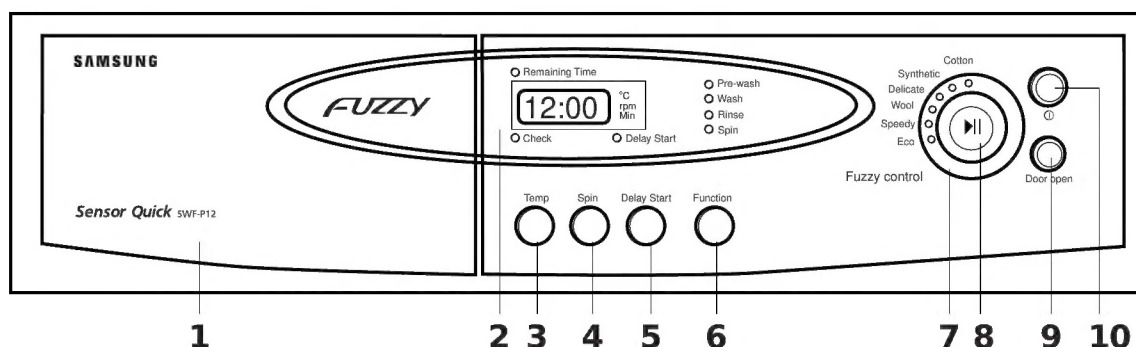

1. Detergent dispenser

2. Display panel

Displays the remaining wash cycle time, error messages and cancel —.

3. Temperature selection button

Press the button repeatedly to cycle through the available water temperature options (cold water, 30°C, 40°C, 60°C and 90°C).

4. Spin selection button

Press the button repeatedly to cycle through the available spin speed options

P12 : (400, 600, 800, 900, 1000, and 1200 rpms.),

P10 : (400, 600, 800, 900 and 1000rpms),

P8 : (400, 600 and 800 rpms).

5. Delay Start button

Press the button repeatedly to cycle through the available delayed start options (from 1 hour to 24 hours in one hour increments).

6. Function button

Press the button repeatedly to cycle through the available partial wash options (Prewash, Wash, Rinse, or Spin).

7. Fuzzy Control dial

Turn the dial to select one of the six available wash programs (Eco, Speedy, Wool, Delicate, Synthetic or Cotton).

8. (Start/Pause) button

Press to pause and restart programs.

9. Door Open button

Press to open the washing machine door.

10. 1) (On/Off) button

Press once to turn the washing machine on, press again to turn the washing machine off. If the washing machine power is left on for longer than 10minutes without any buttons being touched, the power automatically turns off.

4. Process table

DIVISION	WATER SUPPLY		WASHING		RINSING 1				RINSING 2				RINSING 3				SPINNING																																												
	LOAD (kg)	WATER TEMP SELECT	WASH TIME	WASHING WATER CURRENT	REVERSE rpm	RINSE TIME	INTERMEDIATE SPINNING	SPINNING TIME	REVERSE rpm	RINSE TIME	WATER CURRENT TIME	INTERMEDIATE SPINNING	SPINNING TIME	REVERSE rpm	RINSE TIME	WATER CURRENT TIME	INTERMEDIATE SPINNING	SPINNING TIME	REVERSE rpm	SPINNING rpm																																									
COTTON	1.5	COLD WATER	X	9 / 6	48	4min	850	100sec	45	3min	8 / 5	850	100sec	45	3min	8 / 5	850	100sec	45	850	7'40"																																								
		30°C																																																											
		40°C																																																											
		60°C																																																											
		90°C																																																											
		COLD WATER	X																																																										
		30°C																																																											
		40°C																																																											
		60°C																																																											
		90°C																																																											
COTTON	3.0	COLD WATER	O	9 / 6	48	4min	850	100sec	45	3min	8 / 5	850	100sec	45	3min	8 / 5	850	100sec	45	850	7'40"																																								
		30°C																																																											
		40°C																																																											
		60°C																																																											
		90°C																																																											
		COLD WATER	X																																																										
		30°C																																																											
		40°C																																																											
		60°C																																																											
		90°C																																																											
SYNTHETIC	2.5	COLD WATER	O	7 / 8	40	3min	850	60sec	40	3min	7 / 8	850	60sec	40	3min	7 / 8	850	60sec	40	850	100sec																																								
		30°C																																																											
		40°C																																																											
		60°C																																																											
		COLD WATER	X																																																										
		30°C																																																											
		40°C																																																											
		60°C																																																											
		DELICATE	2.0																			COLD WATER	X	6 / 7	30	2min	400	40sec	30	2min	6 / 7	400	40sec	30	2min	6 / 7	400	40sec	30	600	100sec																				
																						30°C																																							
40°C																																																													
COLD WATER	O																																																												
30°C																																																													
40°C																																																													
WOOL	1.5			COLD WATER	X	3 / 12	25	2min	200	60sec	25	1min	3 / 7	200	60sec	25	1min	3 / 7	200	60sec	25	400	60sec																																						
				30°C																																																									
				COLD WATER	O																																																								
				30°C																																																									
		ECONOMY	1.5	COLD WATER	X																			9 / 6	40	3min	600	60sec	40	3min	9 / 6	600	60sec	40	3min	9 / 6	600	60sec	40	850	150sec																				
				30°C																																																									
				COLD WATER	X																																																								
				30°C																																																									
				SPEEY	2.0																																					COLD WATER	O	12 / 3	45	3min	850	60sec	45	2min	10 / 5	850	60sec	45	2min	10 / 5	850	60sec	45	850	150sec
																																										30°C																			
40°C																																																													
COLD WATER	X																																																												
30°C																																																													
PRE	5.0					COLD WATER	X	9 / 6	40	-	-	-	-	-	-	-	-	-	-	-	-	-	-																			850	100sec																		
		30°C																																																											
		40°C																																																											
		COLD WATER	O																																																										
		30°C																																																											
		40°C																																																											

5. General Error Function

• When an error occurs, this function starts to keep generating error melody sounds and displays error indicators as shown in the followings per corresponding error by blinking in 0.5sec interval until the error status is completely cleared out. In this case, all the driving devices are turned off until the error is cleared out.

1. WATER SUPPLY ERROR

- Water Supply Error occurs when water level frequency does not show changes more than 50Hz or water is not supplied up to the water level presetting for 20 min or more at the time of initial water supply, the error status can be cleared by turning POWER S/W OFF and resuming the POWER ON initial status.
- Display shows 'E1'.

2. WATER DRAIN ERROR

- In case the water level frequency is 25.3KHz or less in the initial phase of UNB-detecting cycle.
- Water Drain error can be cleared by turning POWER S/W OFF and resuming the POWER ON initial status.
- Display shows 'E2'.

3. OVER-FLOW ERROR

- Over-Flow error occurs when the water level is in abnormal operation (OVER-FLOW: 22.40KHz/50B\$ or more). It can be cleared by turning POWER S/W OFF. Water is drained prior to POWER S/W OFF and it is forced to be drained for 2 min if a frequency of more than 25.24 KHz is detected.
- Display shows 'E3'.

4. DOOR OPEN ERROR

- Door Open error can be cleared by closing the door.
- Display shows 'door'.

5. UNBALANCE ERROR

- Unbalance error is cleared by POWER S/W OFF and by resuming the POWER ON initial status.
- Display shows 'E4'.

6. WATER HEATER ERROR

- In case the water temperature varies by 40°C or more in 5 min, or by 2°C or less in 10 min after heating is started.
- It can be cleared by turning POWER S/W OFF.
- Display shows 'E5,E6'.

7. ASS'Y PRESSURE S/W ERROR

* Generated Frequency Signal of WATER LEVEL(W/L) S/W (KHz)

Lvevl	Low Level	High Level
Abnormal W/L Frequency	30.00 KHz	15.00 KHz

- If the same signal as the above table is detected for more than 5 seconds, it is a PRESSURE S/W Error.
- When the error occurs, perform the time-drain for 3 min and then turn off the water drain pump. Then the display shows 'E7' as a pressure s/w error indicator.

8. ABNORMAL WATER TEMPERATURE ERROR

Course	Water Temp
Synthetic	60°C or more
Delicate	50°C or more
Wool	40°C or more

- In case the water temperature is 60°C or more in the synthetic course, 50°C or more in the delicate course, and 40°C or more in the wool course.
- At the time of initial water supply, if the water temperature is not appropriate, water starts to be drained and it is forced to be drained for 2 min when the abnormal frequency of 25.24KHz is detected.
- Display shows 'E8'.
- This error can be cleared by POWER S/W OFF.

6. Trouble Diagnosis

° As the micom wash machine is configured of the complicate structure, there might be the service call.
Below information is prepared for exact trouble diagnosis and suitable repair guide.

Caution for the Repair and Replacement

Please follow below instruction for the trouble diagnosis and parts replacement.

- 1) As some electronic components are damaged by the charged static electricity from the resin part of wash machine or the human body, prepare the human body earth or remove the potential difference of the human body and wash machine by contacting the power supply plug when the work contacting to PCB is executed.

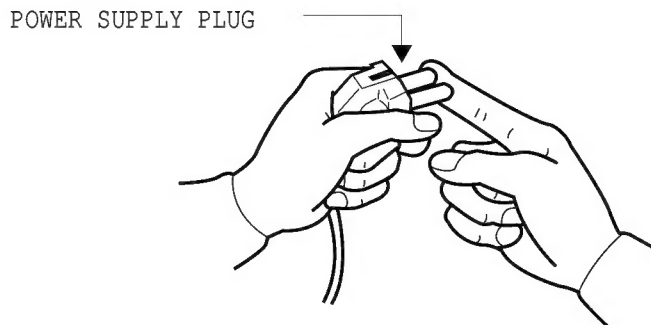

- 2) Since AC220~240V is applied to the triac T1 and T2 on P.C.B, the electric shock may occur by touching and be careful that the strong and weak electricity are mixed.
- 3) If the P.C.B assembly is out of order, do not replace the component on P.C.B except TACT switch since the component is coated by the urethane.
- 4) As the P.C.B assembly is designed for no trouble, do not replace the P.C.B assembly by the wrong diagnosis and follow the procedure of the trouble diagnosis when the micom is not operated normally.
- 5) As the parts on P.C.B are coated by the urethane, they can not be tested by the test bar of the meter. Check the trouble by the test mode method according to the procedure.

6. Trouble Diagnosis

No	Item	Cause and treatment
1	The power is not supplied	<ul style="list-style-type: none"> - Is the PCB connector connected well? - Is the voltage normal? - Is the power supply plug connected well? - Is the noise filter connected well? - Is the secondary output of the power supply transformation normal? - Is the fuse disconnected? • If above points are not found, the PCB assembly is out of order. Replace it.
2	The water is not supplied.	<ul style="list-style-type: none"> - Is the knob open? - Did you push START/PAUSE button after selecting the course? - Is the water supply valve connected well? - Is the winding of the water supply valve continuous? - Is the connection and operation of the pressure switch normal? • If above points are not found, the PCB assembly is out of order. Replace it.
3	The wash does not start though the water supply is stopped.	<ul style="list-style-type: none"> - Is the connection and operation of the pressure switch normal? - Is the pressure switch hose damaged so that the air is leaked? - Is the pressure switch hose bent? - Check the operation of the water level switch. • If above points are not found, the PCB assembly is out of order. Replace it.
4	The wash is executed while the water is supplied.	<ul style="list-style-type: none"> - The PCB assembly is out of order. Replace it.
5	The drum does not rotate during washing.	<ul style="list-style-type: none"> - Is the belt connected well? - Is the winding of the motor continuous? (Rotor winding, stator winding, generator) - Is the motor fuse normal? • If above points are not found, the PCB assembly is out of order. Replace it.
6	The drum rotates by one direction during washing. (The drum rotates to one direction for SPIN.)	<ul style="list-style-type: none"> - The PCB assembly is out of order. Replace it. (Inversion relay open trouble)
7	Drainage problem.	<ul style="list-style-type: none"> - Is the drainage hose bent? - Is the winding of the drainage pump continuous? - Is the drain filter clogged by the waste? • If above points are not found, the PCB assembly is out of order. Replace it.
8	Dehydration problem.	<ul style="list-style-type: none"> - The unbalance is detected. - Put in the laundry uniformly and start again.
9	Abnormal noise during SPIN.	<ul style="list-style-type: none"> - Is the pulley nut loosen? - Is the transport safety device removed? - Is the product installed on the level and stable place? (Little noise may be generated during the high-speed SPIN.)
10	Leak breaker or current/leak breaker is down during washing.	<p><When the leak breaker and current breaker is installed separately></p> <ul style="list-style-type: none"> - When the leak breaker is down, check and make the earth of the outlet. - When the current is down, the current is leaked. <p><Is the breaker down when the leak/current breaker is combined?></p> <ul style="list-style-type: none"> - Check the rated capacity of the current and leak breaker. <p>The current breaker may be down due to the lack of the current when the wash machine and other apparatus are used. In this case, execute the cold water wash to check whether the current capacity is lack.</p>
11	The heating is not executed.	<ul style="list-style-type: none"> - Is the wash heater terminal unplugged? - Is the wash heater normal?(Resistance value : 20.5~21.5Ω) - If above points are not found, the PCB assembly is out of order. Replace it.

7. Test Mode

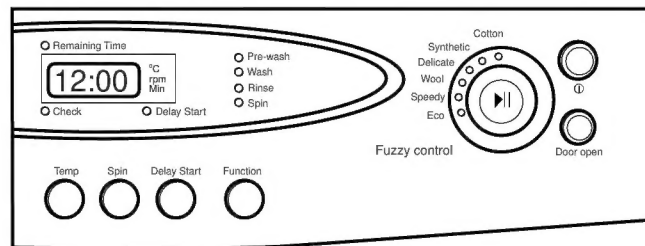

1. Driving Compartment Test Mode

- Hold down "Temp" and "Delay Start" keys simultaneously and then press POWER S/W on.
(Display shows "tEST")
Hold down "Delay Start" and "Temp" keys simultaneously (each processing for 0.3sec) and then press POWER S/W on.
- The driving compartment can be tested when you press START/PAUSE key right after entering into the initial stage of the TEST MODE.

• Driving Compartment Test

Pre-wash VALVE ON(0.3sec) → OFF(0.3sec) → Main wash(0.3sec) → OFF(0.3sec) → Rinse VALVE ON(0.3sec) → OFF(0.3sec) → Spin MOTOR ON(0.3sec) → OFF(0.3sec) → MOTOR RELAY1 ON(0.3sec) → OFF(0.3sec) → MOTOR RELAY2(0.3sec) → OFF(0.3sec) → MOTOR RELAY2 ON(0.3sec) → OFF(0.3sec) → HEATER RELAY ON(0.3sec) → OFF(0.3sec) → DOOR OPEN (Function continues when door is closed)

2. THERMISTOR TEST MODE

- Hold down "Delay Star" and Function keys simultaneously and then press POWER S/W on.
- Display shows the current THERMISTOR data index in celsius degrees.

TEMP	5	10	15	20	25	30	35	40	45
DATA	5	10	15	20	25	30	35	40	45
TEMP	50	55	60	65	70	75	80	85	90
DATA	50	55	60	65	70	75	80	85	90

3. UNBALANCE TEST MODE

- Hold down "Temp" and "Spin" keys simultaneously and then press POWER S/W ON.
- Display shows "Unbt" and the machine starts to sense the degree of deviation of the laundry balance for 9 minutes via 1st and 2nd selection.
- After selecting the deviation degree of the laundry balance, it displays the data(in hex value) for 10 seconds.

4. LOAD AMOUNT SENSING TEST MODE

- Hold down "Door Open" key and then press POWER S/W ON.
- Display shows '0000' and the machine starts to measure the dropping time from 600 RPM to 100 RPM for 1minute.
- After selecting the amount of load, it display the data in a hex value.

8. Designation of Main Components

8-1 Normal / Reverse Revolution of Motor and R. P. M. Control

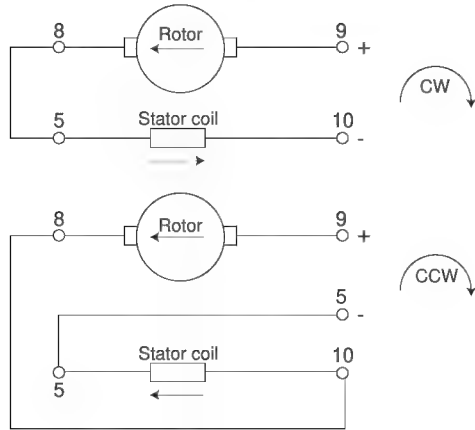

<Figure1>

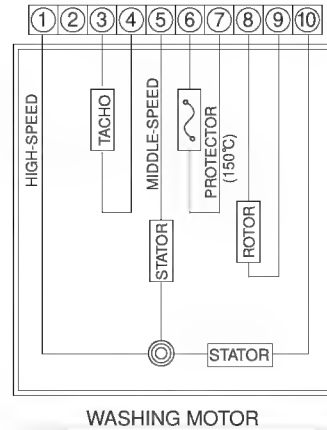

<Figure2>

- The resistance value can be slightly changed by the temperature.

	STATOR(5.10)	STATOR(5.1)	ROTOR(8.9)	TACHO(3.4)	PROTECTOR(6.7)
Resistance value	1.64 Ω	0.91 Ω	1.9 Ω	42.7 Ω	0
Rated value	220~240V / 50Hz				

8-2 Door safety Device

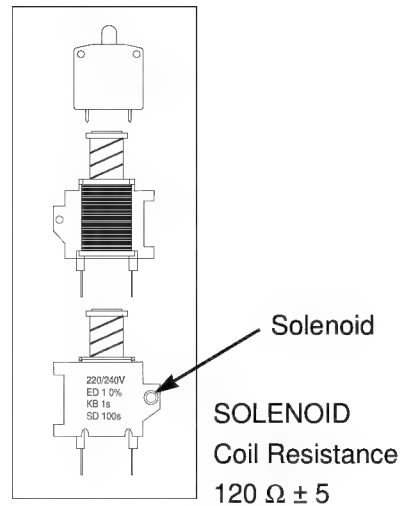
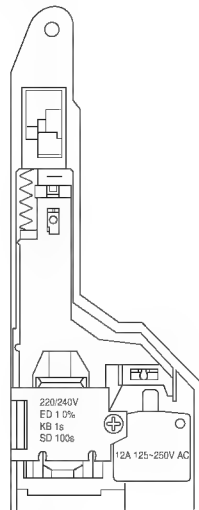

8-3 Heater

- 1) Capacity : AC 230V/2500W
- 2) Location : Bottom of TUB
- 3) Function : Raise the water temperature supplied at the wash process.
- 4) Resistance value : 20.5Ω ~ 21.5Ω
- 5) Thermo Fuse : 128°C

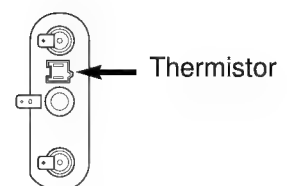
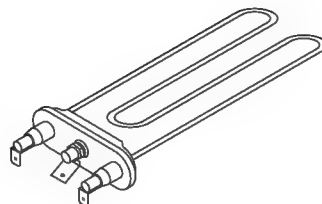

10. Assemble and Disassemble

1. ASS'Y-COVER TOP

- 1) Remove two screws fixing the top-cover on back side.
- 2) Push the top-cover back about 15mm and pull it up.
- 3) It's possible to exchange and service the transformer, the pressure-senser, the noise-filter and the water valve.

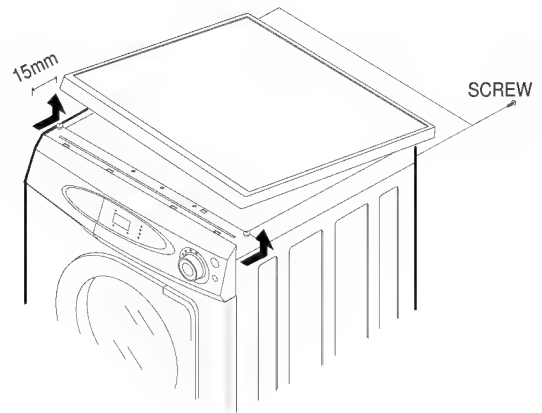

2. FRAME FRONT

- 1) Remove the top-cover and the ass'y drawer.
- 2) Remove two screws fixing the control-panel on front side and the screw on right side.
- 3) Remove the cover-front(L) by using the (-)driver.
- 4) Pull the lever and open the ass'y-door.
- 5) Part the diaphragm and the wire diaphragm away from the frame-front.
- 6) Remove the eight screws fixing the frame-front.
- 7) It's possible to exchange and service the heater, the pump, the shock-absorber and the door lock s/w.

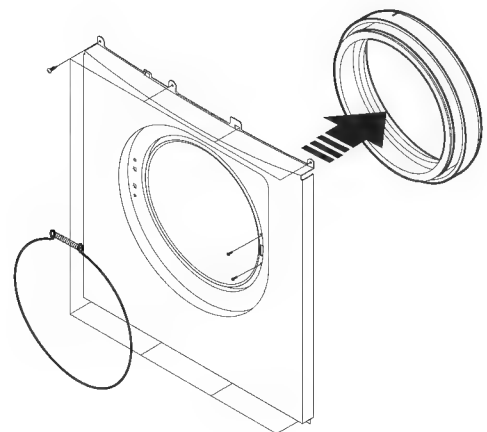
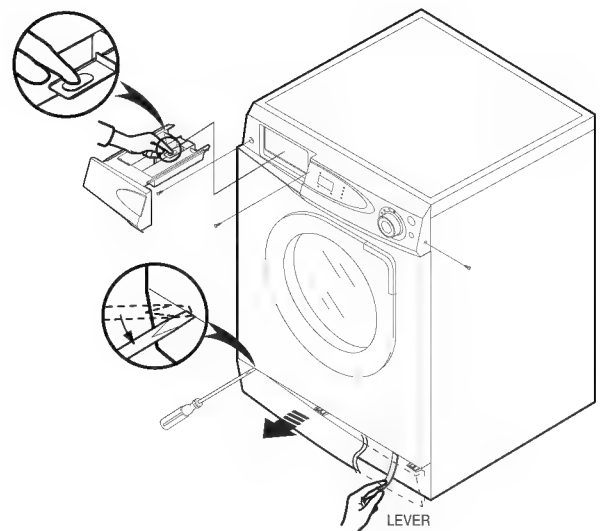

10. Assemble and Disassemble

3. BELT

- 1) Remove the top-cover.
- 2) Disassemble and assemble the belt.
- 3) Check the belt is located at center of the motor-pulley.
<When assemble the belt>
Hook the belt on the motor pulley 1) and place it around the pulley 2).

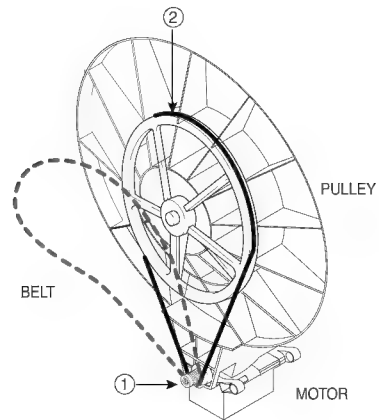

4. MOTOR

- 1) Lay down the washer on left side.
- 2) Remove the wire housing from the motor.
- 3) Remove the bolt fixing the motor with the box drive on back side.
- 4) Remove the motor.

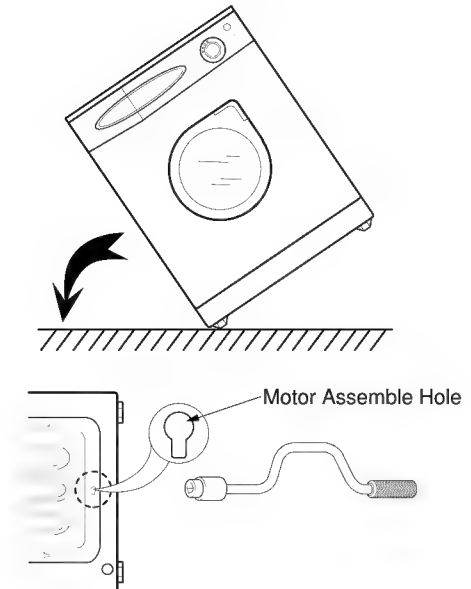

5. How to Assemble the RELAY Housing.

<CAUTION>

Insert the Relay Housing to the Relays on the opposite direction each other.

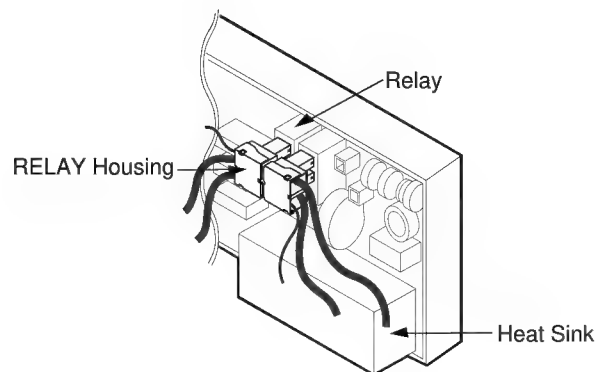

11. Tools for Disassembly and Assembly

NO	TOOL		
1	Box driver	10mm 13mm 17mm 19mm	Heater (1) Motor (1), Balance (5) 2 holes of each left and right of the shock absorber 1 Pulley hole
2	Double-ended spanner	10, 13 17, 19mm	Replaceable for the box driver. Since the bolt runs idle when the box driver is used, use the box driver 17mm.
3	Vice pliers		Tool to protect the idle and abrasion of the bolt for the box driver.
4	Other(Driver, Nipper, Long nose)		General tools for the after service.
5	JIG for the Tub		1 (Disassemble and Assemble)

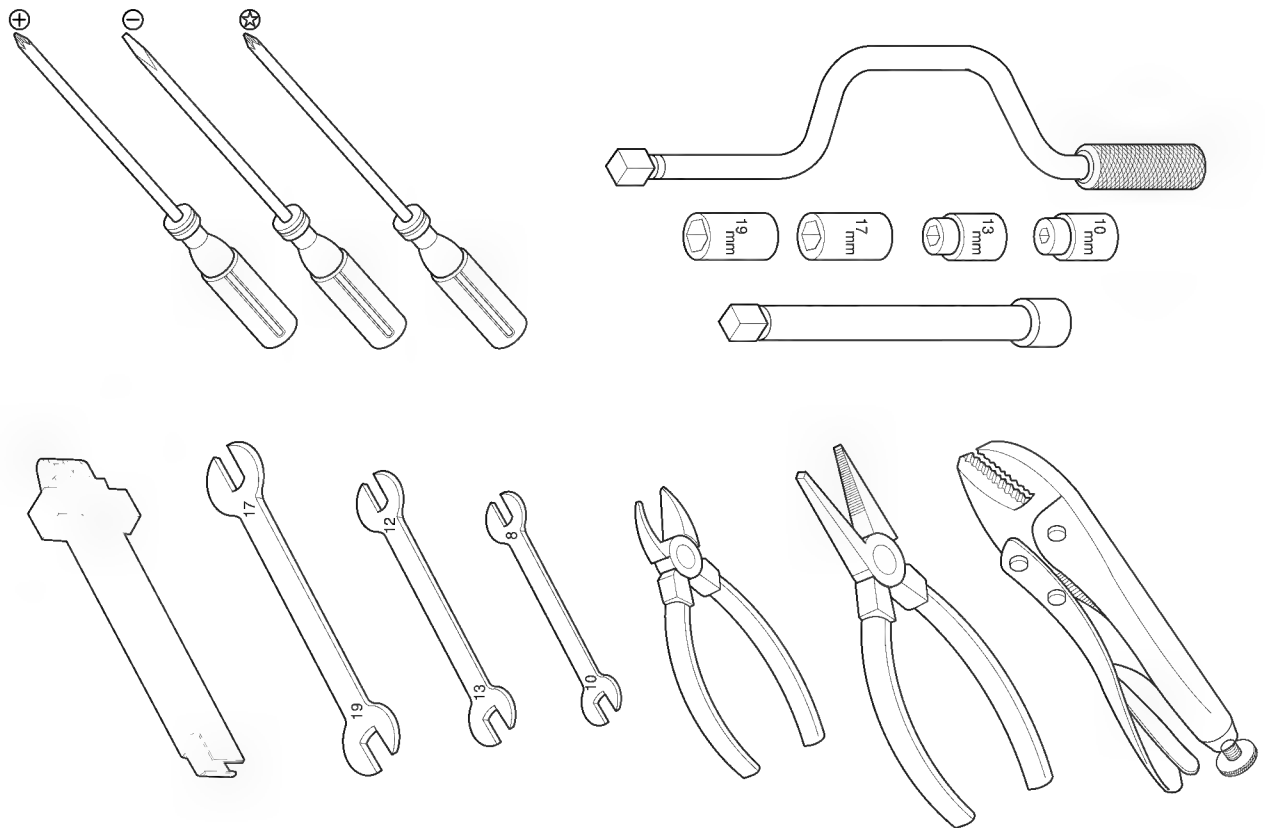

12. Expolded View and Parts List

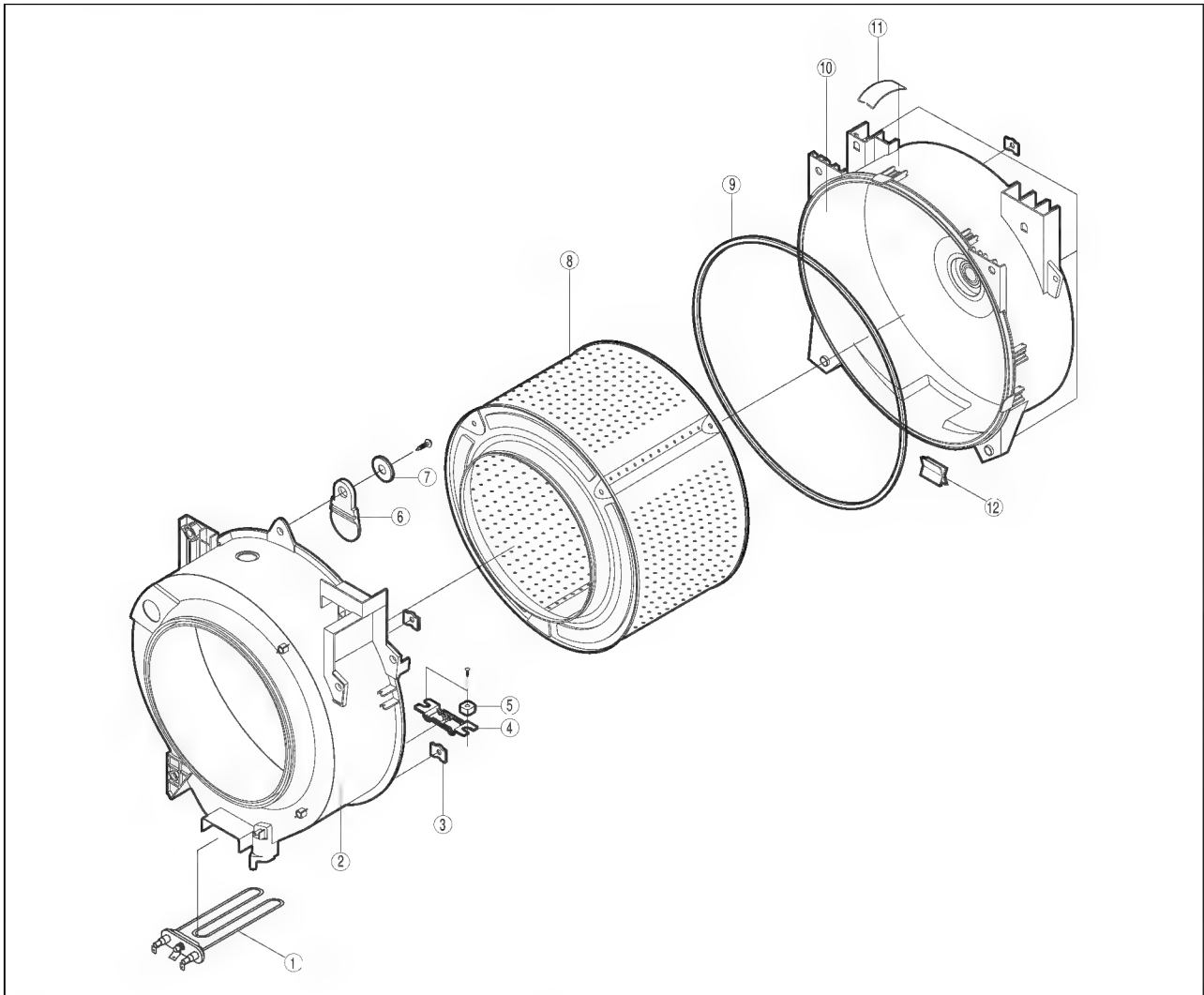

NO.	Description	Code No.	Q'ty	Secification
1	HEATER-WATER ELEMENT	DC62-50123A	1	AISI-304L AC230V/2500W
2	TUB-FRONT	DC61-30346A	1	PP(GR30%) IVORY
3	BRACKET-NUT	DC61-40348A	7	SBHG-R T3
4	BRACKET-HEATER	DC61-40344A	1	STS430 T1
5	SPACER-HEATER	DC61-60496A	2	PBT
6	VANE-CHECK	DC62-20311A	1	EPDM BLK
7	WASHER-PLAIN	DC60-60188A	1	ID4.5 OD15.5 T1
8	ASSY-DRUM	DC91-12281A	1	SWF-P8/P10/P12
9	PACKING-TUB	DC62-40183A	1	EPDM BLK
10	TUB-BACK	DC61-30347A	1	PP(GR30%) IVORY
11	CLIP-TUB	DC61-60499A	8	HSWR
12	CLIP TUB(P)	DC61-60520A	1	SK5 ZPC3

12. Expolded View and Parts List

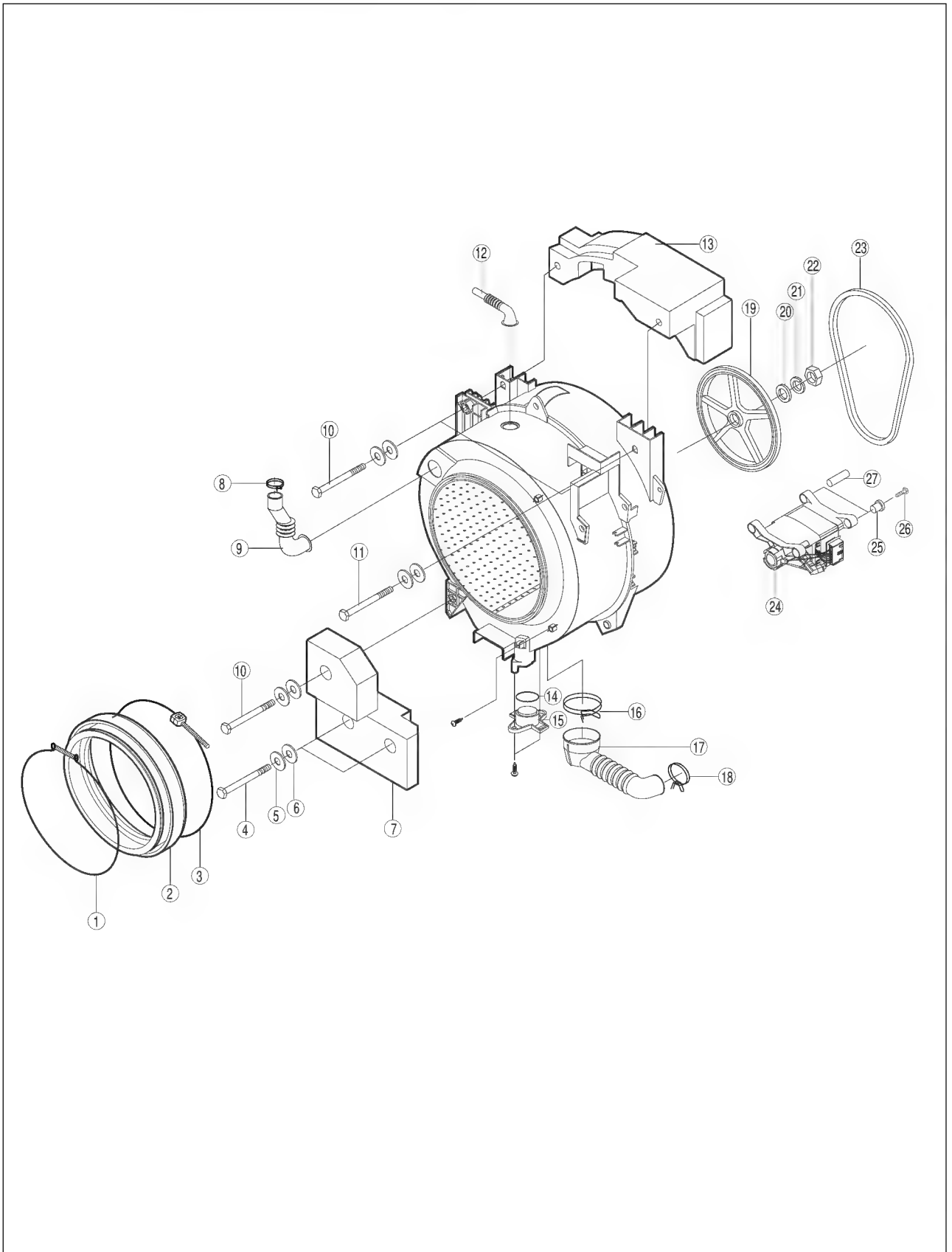

12. Exploded View and Parts List

NO.	Description	Code No.	Q'ty	Secification
1	ASSY-WIRE DIAPHRAGM	DC91-12078A	1	
2	DOOR-DIAPHRAGM	DC61-20219A	1	EPDM GRY SWF-P8/P10/P12
3	ASSY-CLAMP DIAPHGRAM	DC91-12077A	1	
4	BOLT-W.MOTOR	DC60-40138A	2	M8 L70 ZPC2(YEL) SM10C
5	WASHER-PLAIN	DC60-60044B	5	ID8.4 OD13 T4.3 SBC
6	WASHER-NYLON	DC60-60040A	3	ID10.5 OD32 T2 PBSP-1/2H
7	WEIGHT-BALANCER	DC66-60154A	1	CONCRETE SWF-P12 LOWER
8	CLAMP-HOSE	DC61-60359A	1	HSWR
9	HOSE-DRAWER TUB	DC62-10305A	1	EPDM ID35 BLK L158
10	BOLT-HEX	DC60-40140A	2	M8 L140 ZPC2/YEL WEIGHT-UL/SM1
11	BOLT-FLANGE	DC60-40132A	1	M8 L205 ZPC2 SS41C
12	HOSE-AIR	DC62-10303A	1	EPDM ID24 BLK L130
13	WEIGHT-BALANCER	DC66-60153A	1	CONCRETE SWF-P12 UPPER
14	PACKING-TRAP	DC62-40184A	1	EPDM BLK
15	CAP-TRAP	DC61-10676A	1	PP(TB53)
16	CLAMP-HOSE	DC61-60497A	1	HSWR SWF-P12 ID70/OD75.8(TUB)
17	HOSE-FILTER TUB	DC62-10304A	1	EPDM ID65 BLK L151
18	BAND-RING	DC65-60118F	1	ID33
19	PULLEY	DC66-10176A	1	ALDC D297
20	WASHER	DC60-60060A	1	
21	WASHER-SPRING	DC60-60049A	1	ID10.5 OD18 T2.5 SIR
22	NUT-HEX	DC60-50014A	1	HEXAGON M(12) ZPC2(YEL) SM10C
23	BELT-TRANSMISSION	DC66-10139A	1	
24	MOTOR-DRUM	DC31-00002C	1	13000rpm 100Nm 220~240VDC 1.8A
25	CUSHION-MOTOR	DC61-00041A	2	NBR SWF-P12 ID13.4/OD28
26	BOLT-W.MOTOR	DC60-40138A	1	M8 L70 ZPC2(YEL) SM10C
27	PIN-SPLIT	DC60-80175A	2	ZPC2(YEL) SM10C

12. Expolded View and Parts List

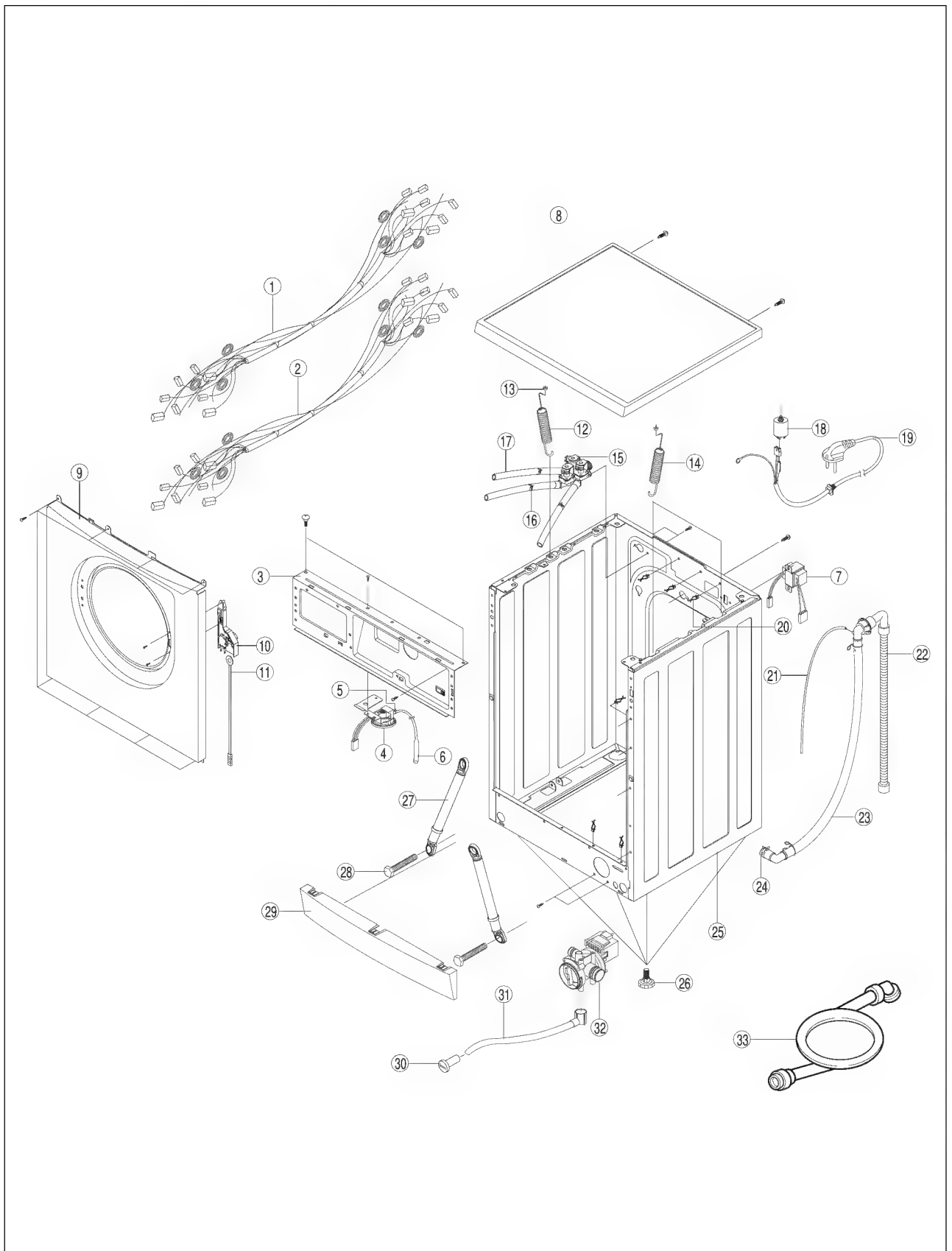

12. Exploded View and Parts List

NO.	Description	Code No.	Q'ty	Secification
1	ASSY-M.WIRE HARNESS	DC90-11153A	1	MAIN-WIRE(A)
2	ASSY-WIRE HARNESS	DC90-11181A	1	SUB
3	FRAME-PLATE(U)	DC61-30344A	1	EGI NTR
4	SENSOR PRESSURE	DC32-30006J	1	SEW-DK
5	CLAMP HOSE	DC61-60063B	1	SK5 YEL
6	HOSE PRESSURE	DC62-10311A	1	EPDM, SWF-P8/P10/P12
7	TRANS-FORMER	DC26-10150E	1	HSG 230V 12VDC 50/60HZ
8	ASSY-COVER TOP	DC91-12083A	1	
9	FRAME-FRONT	DC61-30345A	1	EGI WHT
10	DOOR-LOCK S/W	DC61-20229A	1	230V/50Hz LTD
11	LEVER	DC66-30160A	1	PE+EVA L335
12	SPRING-HANGER	DC61-70216A	1	HSWR SWF-P12 LEFT(OD24)
13	SLEEVE-PLUG	DC61-60180A	3	NYLON#6
14	SPRING-HANGER	DC61-70217A	2	HSWR SWF-P12 RIGHT(OD30))
15	ASSY-VALVE WATER(C)	DC91-12279A	1	
16	CLAMP-HOSE	DC61-60063B	6	SK5 YEL
17	HOSE-DRAWER	DC62-10068A	1	SOFT-PVC ID10 NTR L350
18	FILTER-EMI AC LINE	DC29-90001A	1	250V 15A UL/CSA 2200pF 50x63 B
19	ASSY-POWER CORD	DC90-11099D	1	AC250V/16A(N)/ANGLE
20	HOLDER-WIRE	DC61-40086A	5	NYLON66 DAWH-3NB NTR(PI15)
21	HOSE-VINYL	DC62-10001H	1	VINYL ID4 NTR L670
22	ASSY-HOSE DRAIN(O)	DC91-10352C	1	SWF-P12, L1200(R/Gry)
23	ASSY-HOSE DRAIN(I)	DC91-10351C	1	ID25/BAND
24	BAND RING	DC65-60118F	1	PW1 PI23
25	FRAME	DC61-30342A	1	SBHG1-A NTR
26	ASSY-LEG	DC91-12292A	4	
27	DAMPER-SHOCK	DC66-60149A	2	80N
28	BOLT-HEX	DC60-40026A	2	M10 SCP
29	COVER-FRONT(L)	DC61-10672A	1	PP(BJ-730) WHT
30	CAP-DRAIN	DC61-10673A	1	PP WHT
31	HOSE-DRAIN	DC62-10302A	1	EPDM ID5.5 BLK L220 OD9.5
32	ASSY-PUMP DRAIN	DC90-11110A	1	220/240V50Hz
33	HOSE-WATER(C)	DC62-10289A	1	PVC+WHT+1500

12. Expolred View and Parts List

1-1 Safety precautions

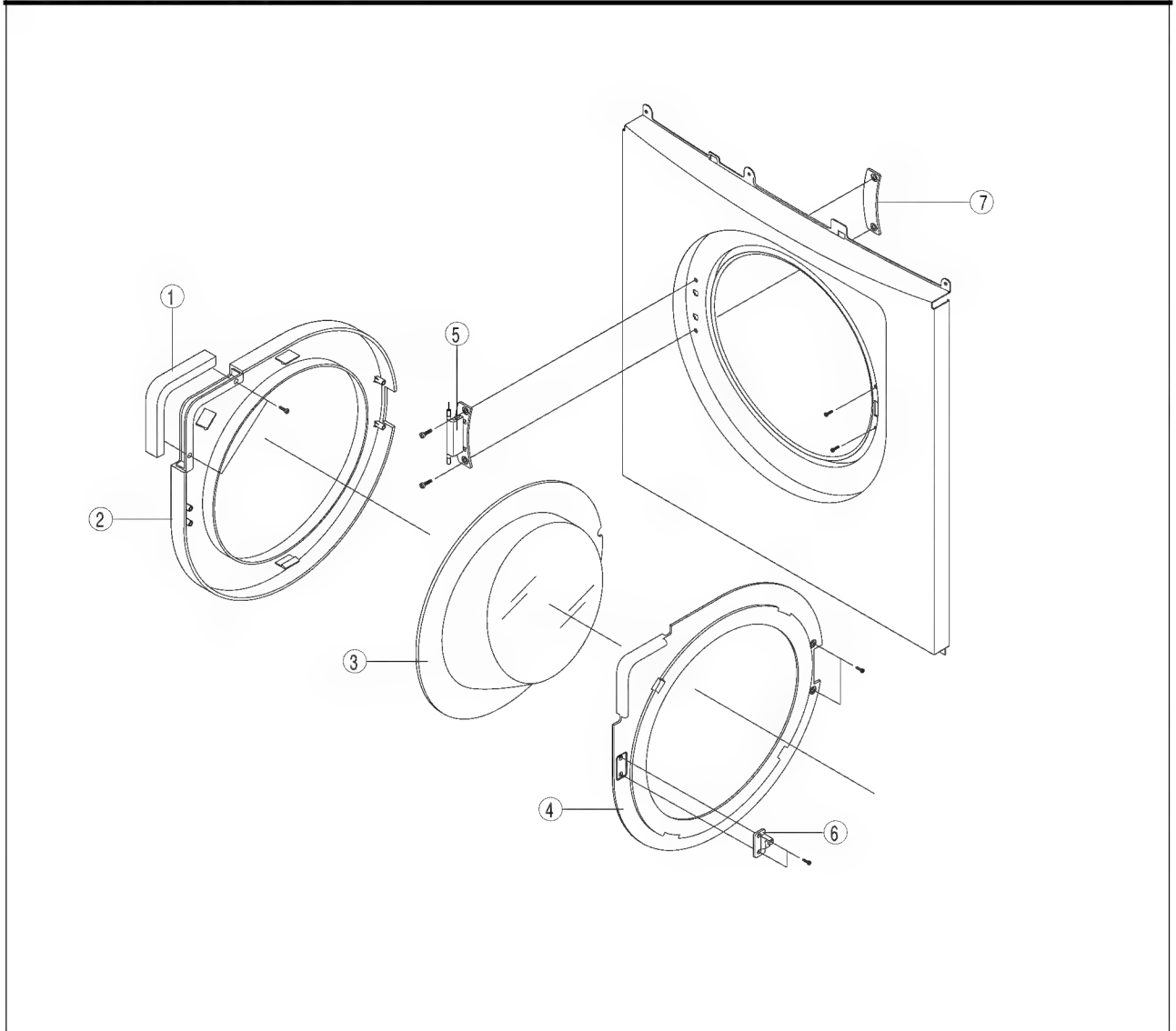

NO.	Description	Code No.	Q'ty	Secification
1	DECORATION-LID	DC64-20013A	1	ABS SWF-P8, P10
2	COVER-DOOR	DC61-10682A	1	ABS WHT
3	DOOR-GLASS	DC61-00013A	1	GLASS NTR SWF-P12
4	HOLDER-GLASS	DC61-40346A	1	ABS WHT
5	ASSY-HINGE	DC97-00100A	1	
6	LEVER-DOOR	DC66-30161A	1	ZnDC L40
7	NUT-FLANGE	DD60-50018A	1	M5

12. Expolded View and Parts List

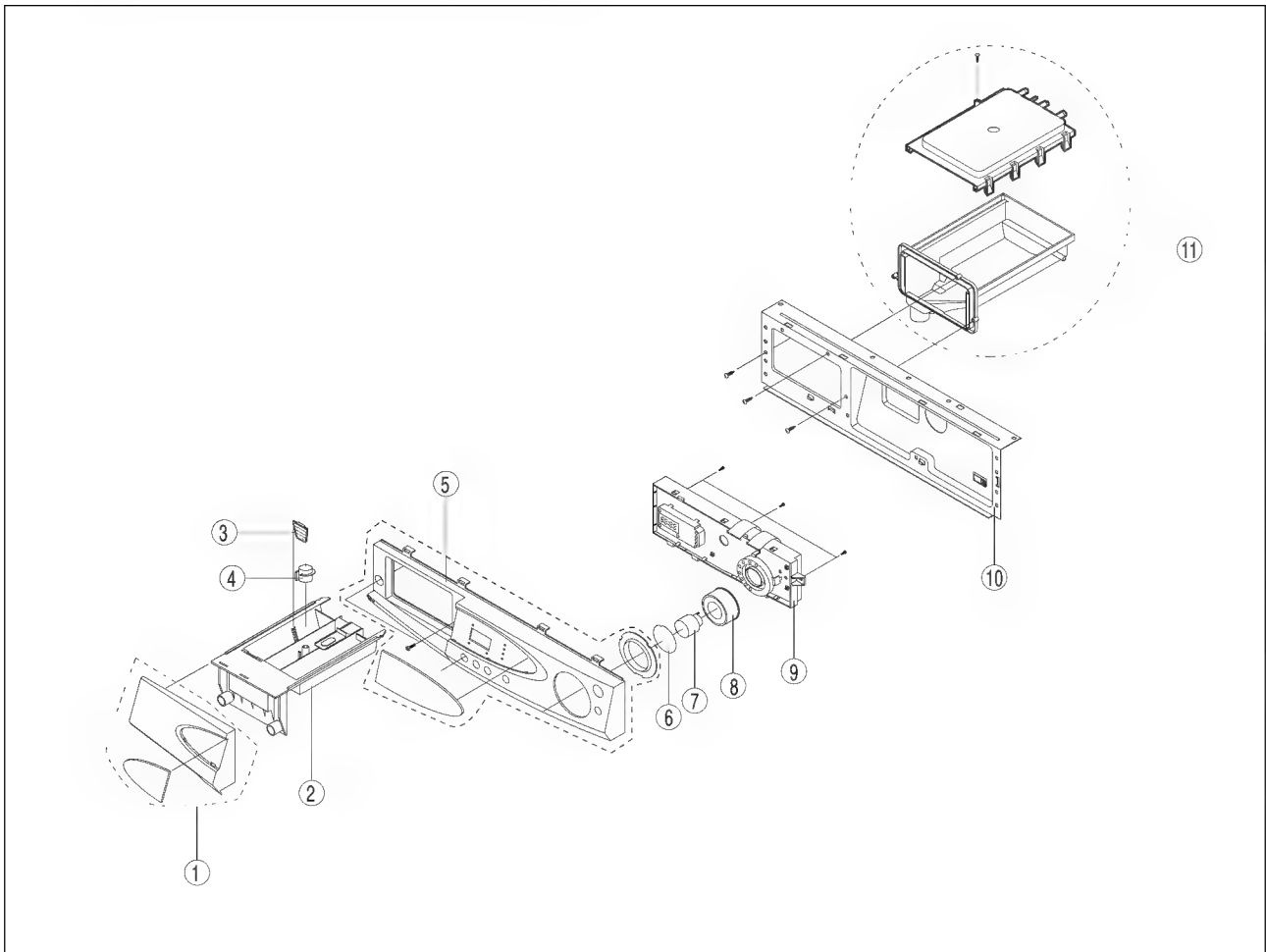

NO.	Description	Code No.	Q'ty	Secification
1	ASSY-PANEL FRONT	DC97-00004B	1	ABS, WHT, SWF-P10
	ASSY-PANEL FRONT	DC97-00004C	1	ABS, WHT, SWF-P8
2	BODY-DRAWER	DC61-30348A	1	PP WHT
3	GUIDE-LIAUID	DC61-60498A	1	ABS
4	CAP-RINSE	DC61-10687A	1	ABS WHT
5	ASSY-PANEL CONTROL	DC97-00003B	1	ENG
6	INLAY-ENCODER	DC64-30087C	1	PC TRP SWF-P12, YLP/YLR/YLU
7	BUTTON-ENCODER	DC64-10408A	1	ABS WHT
8	KNOB-ENCODER	DC64-10407A	1	ABS WHT
9	ASSY-PCB URETHAN	DC90-11195A	1	SWF-P10 EU(COLD)
	ASSY-PCB URETHAN	DC90-11196A	1	SWF-P8 EU(COLD)
	ASSY-PCB URETHAN	DC90-11185A	1	SWF-P12
10	FRAME-PLATE(U)	DC61-30344A	1	EGI, WHT
11	ASSY-HOUSING DRAW	DC91-12084A	1	



ELECTRONICS

9. PCB Schematic Diagram

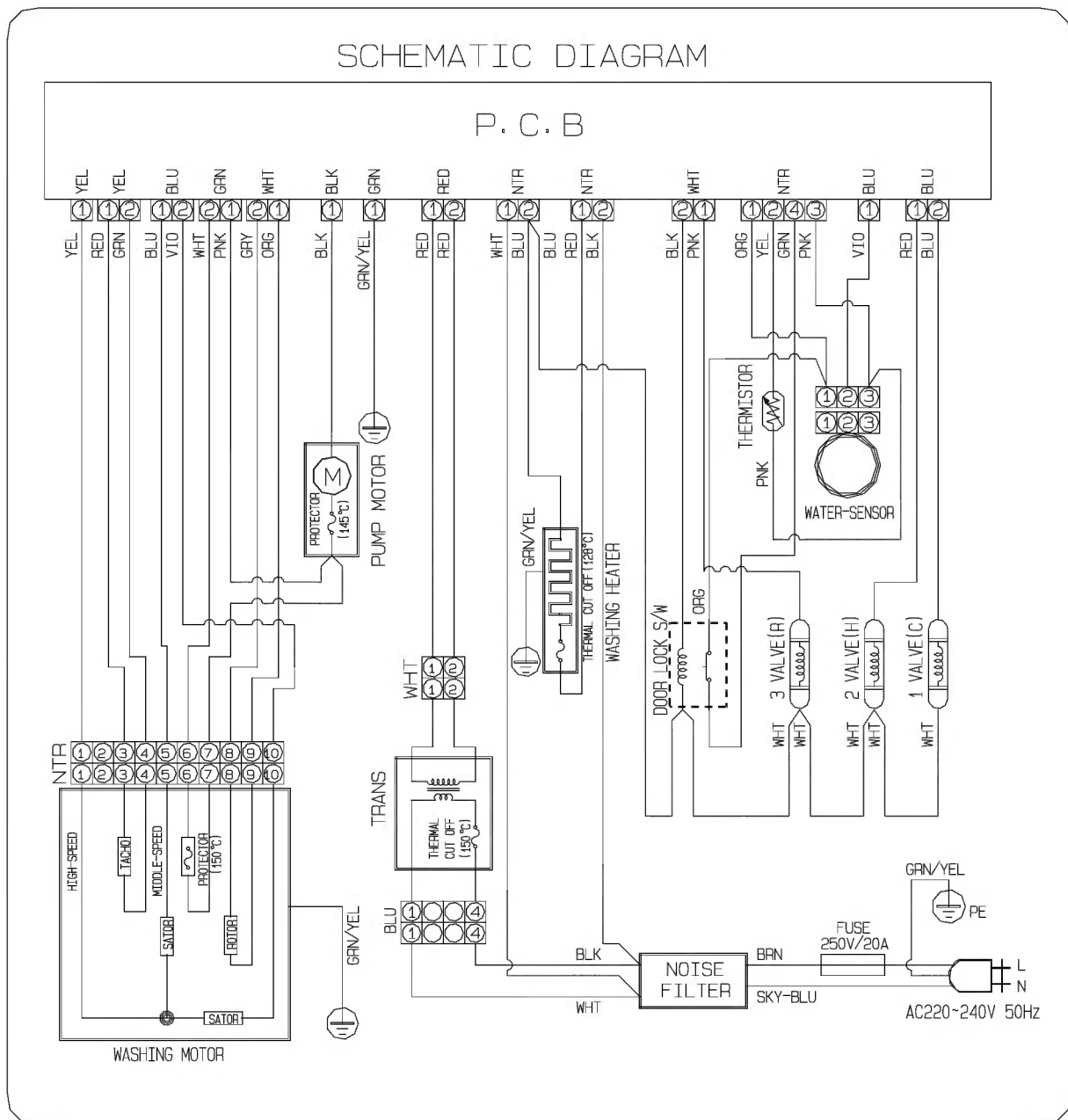

9. PCB Circuit Diagram

9. PCB Pattern Diagram, Wringing Diagram
