



**SAMSUNG**

# Television Video Cassette Recorder

Chassis : C15A  
Model: TB14C52S/XEC TB20C52S/XET  
TB14C5S2S/XEG TB20C5DF2S/XEG  
TB14C5T2S/XEC TB20C5DF2S/XET  
TB14C5DT2S/XET TB20C5DT2S/XEC  
TB21B5DF2S/XEC

# **SERVICE** *Manual*

## Television Video Cassette Recorder



## CONTENTS

1. Precautions
2. Specifications
3. Disassembly and Reassembly
4. Alignment and Adjustment (Mechanical)
5. Alignment and Adjustment (Electrical)
6. Troubleshooting
7. Exploded View and Parts List
8. Electric Parts List
9. Block Diagram
10. PCB Layout
11. Wiring Diagram
12. Schematic Diagrams



**ELECTRONICS**

## 1. Precautions

Follow these safety, servicing and ESD precautions to prevent damage and protect against potential hazards such as electrical shock and X-rays.

### 1-1 Safety Precautions

1. Be sure that all of the built-in protective devices are replaced. Restore any missing protective shields.
2. When reinstalling the chassis and its assemblies, be sure to restore all protective devices, including: nonmetallic control knobs and compartment covers.
3. Make sure that there are no cabinet openings through which people—particularly children—might insert fingers and contact dangerous voltages. Such openings include the spacing between the picture tube and the cabinet mask, excessively wide cabinet ventilation slots, and improperly fitted back covers.

If the measured resistance is less than 1.0 megohm or greater than 5.2 megohms, an abnormality exists that must be corrected before the unit is returned to the customer.

4. Leakage Current Hot Check (Figure 1-1):  
Warning: Do not use an isolation transformer during this test. Use a leakage-current tester or a metering system that complies with American National Standards Institute (ANIS C101.1, Leakage Current for Appliances), and Underwriters Laboratories (UL Publication UL1410, 59.7).
5. With the unit completely reassembled, plug the AC line cord directly into the power outlet. With the unit's AC switch first in the ON position and then OFF, measure the current between a known earth ground (metal water pipe, conduit, etc.) and all exposed metal parts, including: antennas, handle brackets, metal cabinets, screwheads and control shafts. The current measured should not exceed 0.5 milliamp. Reverse the power-plug prongs in the AC outlet and repeat the test.

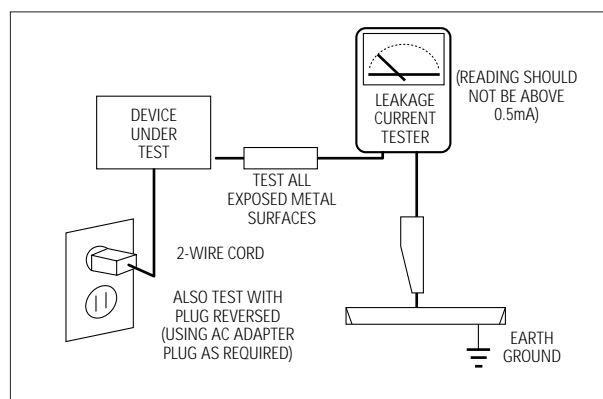



Fig. 1-1 AC Leakage Test

6. Antenna Cold Check:  
With the unit's AC plug disconnected from the AC source, connect an electrical jumper across the two AC prongs. Connect one lead of the ohmmeter to an AC prong. Connect the other lead to the coaxial connector.
7. X-ray Limits:  
The picture tube is especially designed to prohibit X-ray emissions. To ensure continued X-ray protection, replace the picture tube only with one that is the same type as the original. Carefully reinstall the picture tube shields and mounting hardware; these also provide X-ray protection.
8. High Voltage Limits:  
High voltage must be measured each time servicing is done on the B+, horizontal deflection or high voltage circuits. Correct operation of the X-ray protection circuits must be reconfirmed whenever they are serviced.  
(X-ray protection circuits also may be called "horizontal disable" or "hold-down".)

Heed the high voltage limits. These include the X-ray Protection Specifications Label, and the Product Safety and X-ray Warning Note on the service data schematic.

## 1-1 Safety Precautions (Continued)

---

9. High voltage is maintained within specified limits by close-tolerance, safety-related components and adjustments. If the high voltage exceeds the specified limits, check each of the special components.
10. Design Alteration Warning:  
Never alter or add to the mechanical or electrical design of this unit. Example: Do not add auxiliary audio or video connectors. Such alterations might create a safety hazard. Also, any design changes or additions will void the manufacturer's warranty.
11. Hot Chassis Warning:  
Some TV receiver chassis are electrically connected directly to one conductor of the AC power cord. If an isolation transformer is not used, these units may be safely serviced only if the AC power plug is inserted so that the chassis is connected to the ground side of the AC source.  
  
To confirm that the AC power plug is inserted correctly, do the following: Using an AC voltmeter, measure the voltage between the chassis and a known earth ground. If the reading is greater than 1.0V, remove the AC power plug, reverse its polarity and reinsert. Re-measure the voltage between the chassis and ground.
12. Some TV chassis are designed to operate with 85 volts AC between chassis and ground, regardless of the AC plug polarity. These units can be safely serviced only if an isolation transformer inserted between the receiver and the power source.
13. Some TV chassis have a secondary ground system in addition to the main chassis ground. This secondary ground system is not isolated from the AC power line. The two ground systems are electrically separated by insulating material that must not be defeated or altered.
14. Components, parts and wiring that appear to have overheated or that are otherwise damaged should be replaced with parts that meet the original specifications. Always determine the cause of damage or overheating, and correct any potential hazards.
15. Observe the original lead dress, especially near the following areas: Antenna wiring, sharp edges, and especially the AC and high voltage power supplies. Always inspect for pinched, out-of-place, or frayed wiring. Do not change the spacing between components and the printed circuit board. Check the AC power cord for damage. Make sure that leads and components do not touch thermally hot parts.
16. Picture Tube Implosion Warning:  
The picture tube in this receiver employs "integral implosion" protection. To ensure continued implosion protection, make sure that the replacement picture tube is the same as the original.
17. Do not remove, install or handle the picture tube without first putting on shatterproof goggles equipped with side shields. Never handle the picture tube by its neck. Some "in-line" picture tubes are equipped with a permanently attached deflection yoke; do not try to remove such "permanently attached" yokes from the picture tube.
18. Product Safety Notice:  
Some electrical and mechanical parts have special safety-related characteristics which might not be obvious from visual inspection. These safety features and the protection they give might be lost if the replacement component differs from the original—even if the replacement is rated for higher voltage, wattage, etc.  
  
Components that are critical for safety are indicated in the circuit diagram by shading, () or ().  
Use replacement components that have the same ratings, especially for flame resistance and dielectric strength specifications. A replacement part that does not have the same safety characteristics as the original might create shock, fire or other hazards.

## 1-2 Servicing Precautions

---

Warning1: First read the "Safety Precautions" section of this manual. If some unforeseen circumstance creates a conflict between the servicing and safety precautions, always follow the safety precautions.

Warning2: An electrolytic capacitor installed with the wrong polarity might explode.

1. Servicing precautions are printed on the cabinet. Follow them.
2. Always unplug the unit's AC power cord from the AC power source before attempting to: (a) Remove or reinstall any component or assembly, (b) Disconnect an electrical plug or connector, (c) Connect a test component in parallel with an electrolytic capacitor.
3. Some components are raised above the printed circuit board for safety. An insulation tube or tape is sometimes used. The internal wiring is sometimes clamped to prevent contact with thermally hot components. Reinstall all such elements to their original position.
4. After servicing, always check that the screws, components and wiring have been correctly reinstalled. Make sure that the portion around the serviced part has not been damaged.
5. Check the insulation between the blades of the AC plug and accessible conductive parts (examples: metal panels, input terminals and earphone jacks).
6. Insulation Checking Procedure: Disconnect the power cord from the AC source and turn the power switch ON. Connect an insulation resistance meter (500V) to the blades of the AC plug.  
  
The insulation resistance between each blade of the AC plug and accessible conductive parts (see above) should be greater than 1 megohm.
7. Never defeat any of the B+ voltage interlocks. Do not apply AC power to the unit (or any of its assemblies) unless all solid-state heat sinks are correctly installed.
8. Always connect a test instrument's ground lead to the instrument chassis ground before connecting the positive lead; always remove the instrument's ground lead last.

## 1-3 Precautions for Electrostatically Sensitive Devices (ESDs)

---

1. Some semiconductor (“solid state”) devices are easily damaged by static electricity. Such components are called Electrostatically Sensitive Devices (ESDs); examples include integrated circuits and some field-effect transistors. The following techniques will reduce the occurrence of component damage caused by static electricity.
2. Immediately before handling any semiconductor components or assemblies, drain the electrostatic charge from your body by touching a known earth ground. Alternatively, wear a discharging wrist-strap device. (Be sure to remove it prior to applying power—this is an electric shock precaution.)
3. After removing an ESD-equipped assembly, place it on a conductive surface such as aluminum foil to prevent accumulation of electrostatic charge.
4. Do not use freon-propelled chemicals. These can generate electrical charges that damage ESDs.
5. Use only a grounded-tip soldering iron when soldering or unsoldering ESDs.
6. Use only an anti-static solder removal device. Many solder removal devices are not rated as “anti-static”; these can accumulate sufficient electrical charge to damage ESDs.
7. Do not remove a replacement ESD from its protective package until you are ready to install it. Most replacement ESDs are packaged with leads that are electrically shorted together by conductive foam, aluminum foil or other conductive materials.
8. Immediately before removing the protective material from the leads of a replacement ESD, touch the protective material to the chassis or circuit assembly into which the device will be installed.
9. Minimize body motions when handling unpackaged replacement ESDs. Motions such as brushing clothes together, or lifting a foot from a carpeted floor can generate enough static electricity to damage an ESD.

## 2. Specifications

The descriptions and characteristics given in this booklet are given for information purposes only and are subject to modification without notice.

<b>TELEVISION PART</b>	
Colour systems	PAL(option) / SECAM(option) (UK;PAL)
TV standards	L/L'(option), B/G(option), D/K(option) (UK;l)
Number of channels	100 programmes
Reception range/cable TV	Hyperband/interband tuner
Aerial input	75 Ohms, coaxial cable
<b>VCR PART</b>	
Format	VHS standard (PAL / SECAM(option) / MESECAM(option) / NTSC in playback only)
Heads	Video: 2 rotary heads, LP(option), 4 Heads(option) Audio/Control: 1 stationary head (linear) Erase: 1 full track erase head
Luminance	FM azimuth recording
Colour	Down converted subcarrier phase shifted direct recording
FF/REW time	Less than 100 seconds in FF with E-120
Wow and flutter (WTD)	0.4% maximum (SP)
Frequency response	100 Hz - 8 KHz
<b>GENERAL</b>	
Power supply	220-240V~, 50Hz (110-260V~, 50/60Hz; option)
Consumption	14" (60W) 20"/21" (90W)
Audio output power	14" (1.5W) 20" (3W) 21" (1.5Watts x 2)
Number of loudspeakers	14"/20" (1) 21" (2)
Tube size	14" (37cm/34cmV) 20" (51cm/48cmV) 21" (55cm/51cmV)
Tube type	BLACK MATRIX
Sockets	1 full RGB SCART on the rear 1 RCA input (audio and video) on the front Earphones output (3.5 mm mini-jack) 1 aerial/cable TV coaxial input
Dimensions (W x D x H)	14" (368.5 x 388 x 381) 20" (488 x 477 x 488) 21" (520 x 495 x 508)
Weight	14" (11.7 kg) 20" (20.4 kg) 21" (23.2 kg)
Operating temperature	5°C - 40°C (41°F - 104°F)
Relative humidity	10% - 75%

---

## 3. Disassembly and Reassembly

---

### 3-1 Disassembly

---

#### 3-1-1 Back Cover Removal

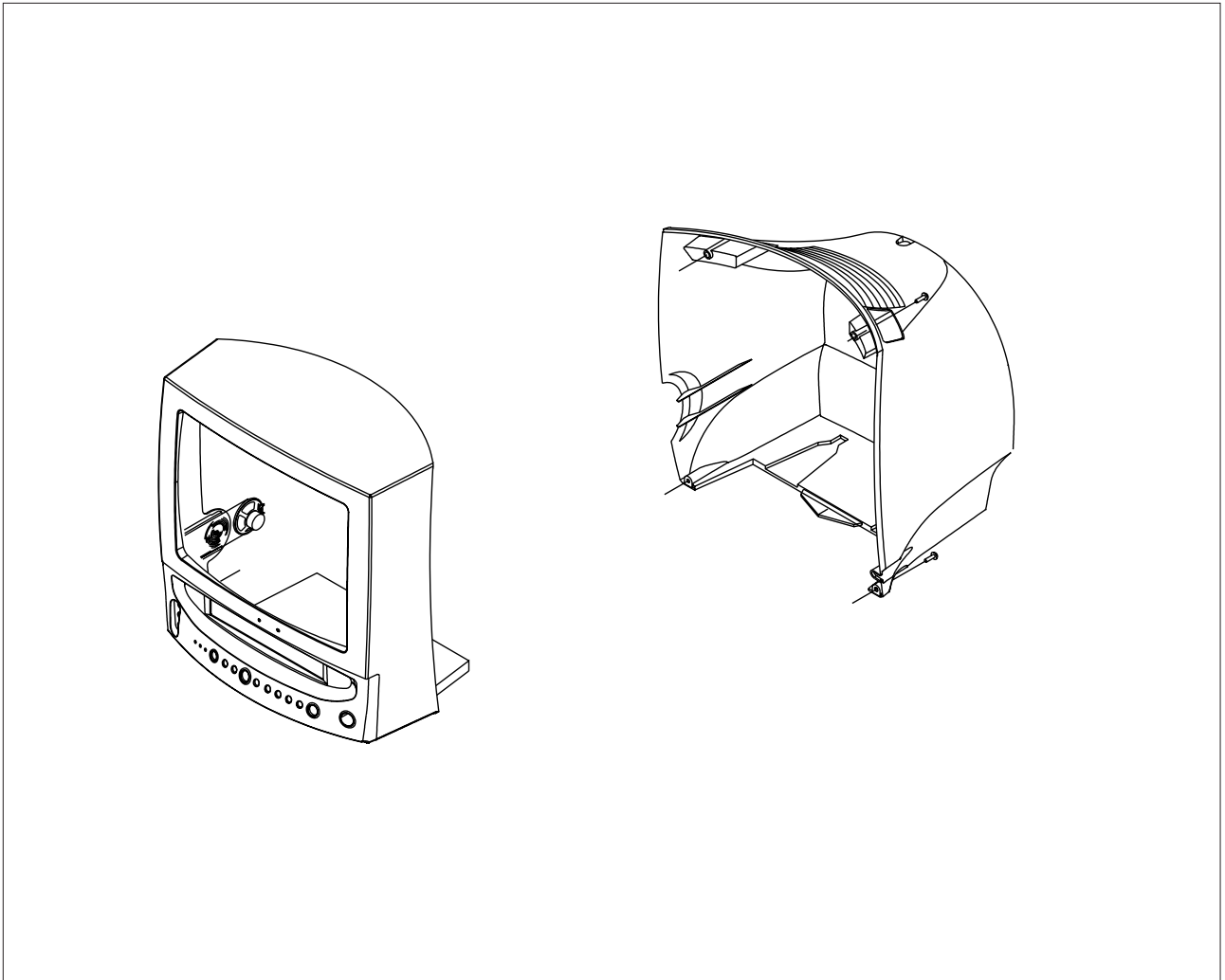

1. Remove the screws located on the side of the back cover.

### 3-1-2 Main Assembly Removal

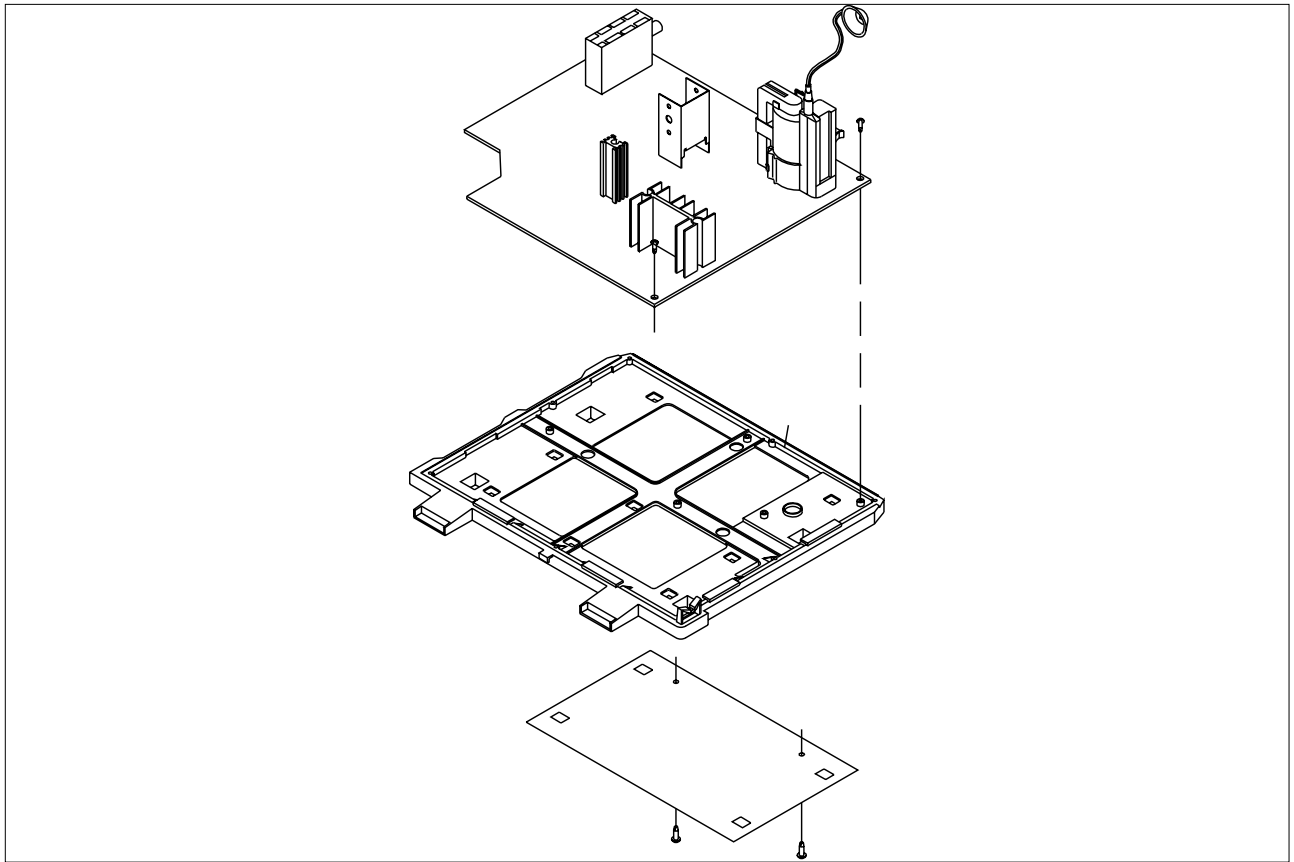

1. Release two connectors between sub PCB and Main Assembly.
2. Pull the Main Assembly backwards to remove.

### 3-1-3 Monitor Frame Removal

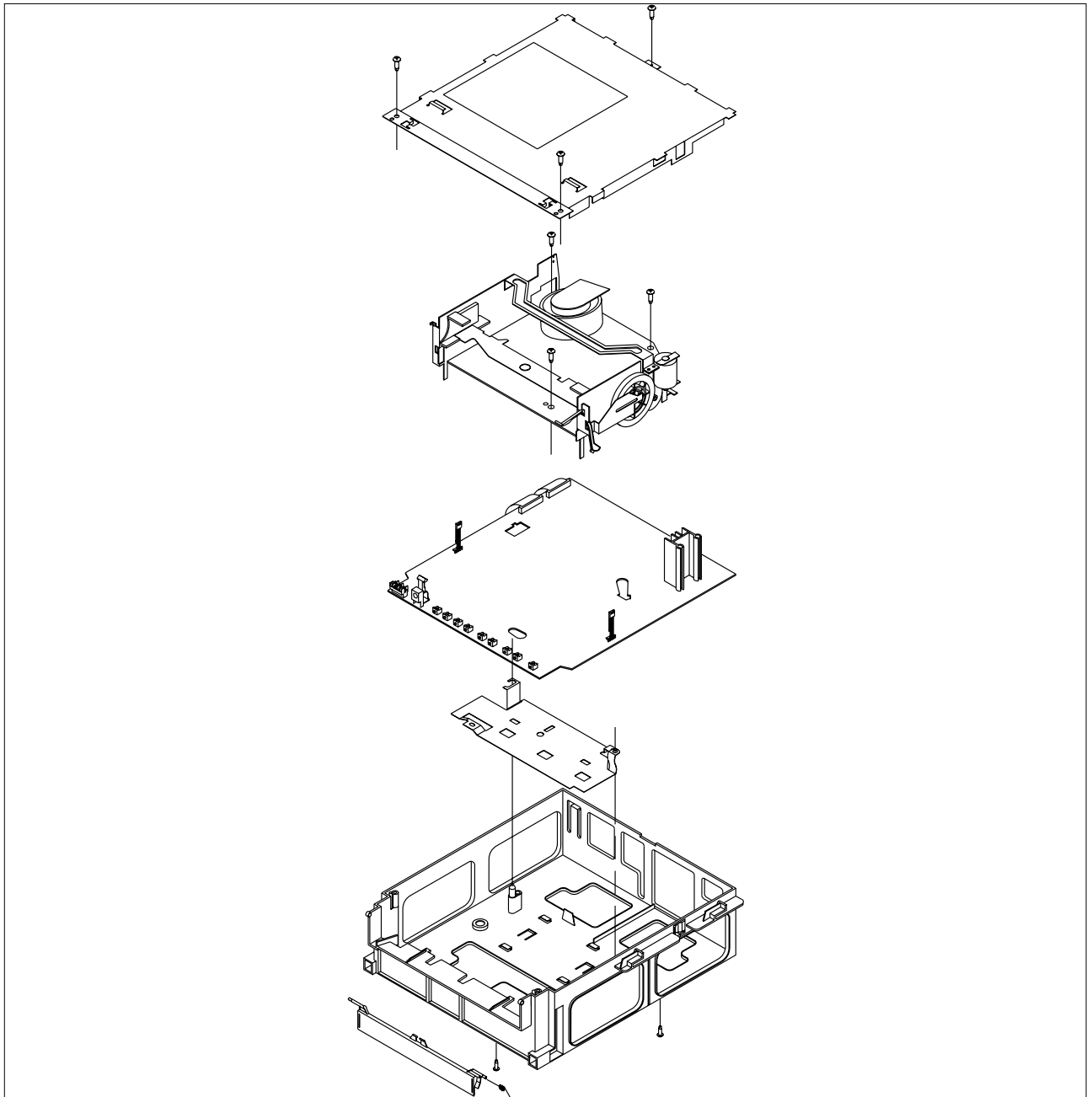

1. Remove 3 screws from the Main Assembly. Remove the dust cover.
2. Remove 4 screws from the Deck Assembly.

### 3-1-4 Deck Assembly Removal

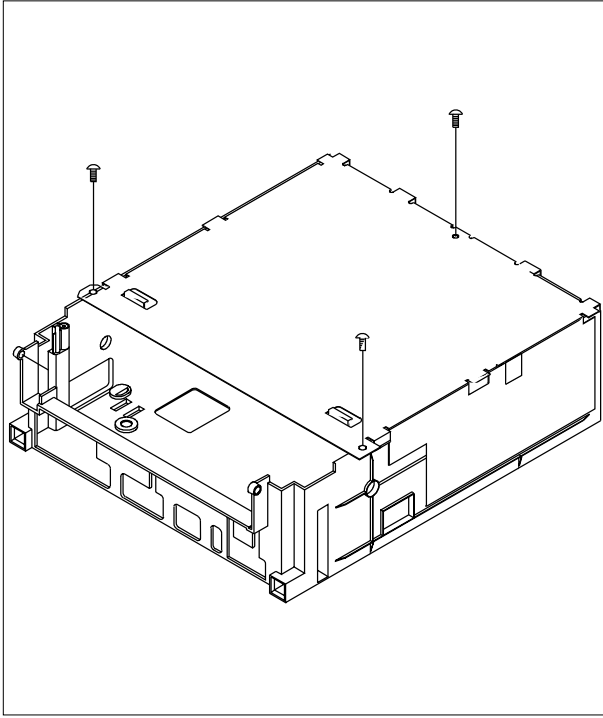

1. Remove 2 screws holding the bottom cover.
2. Remove one screw from Main PCB Assembly. Take off the deck Assembly.

### 3-1-5 Main Assembly Removal

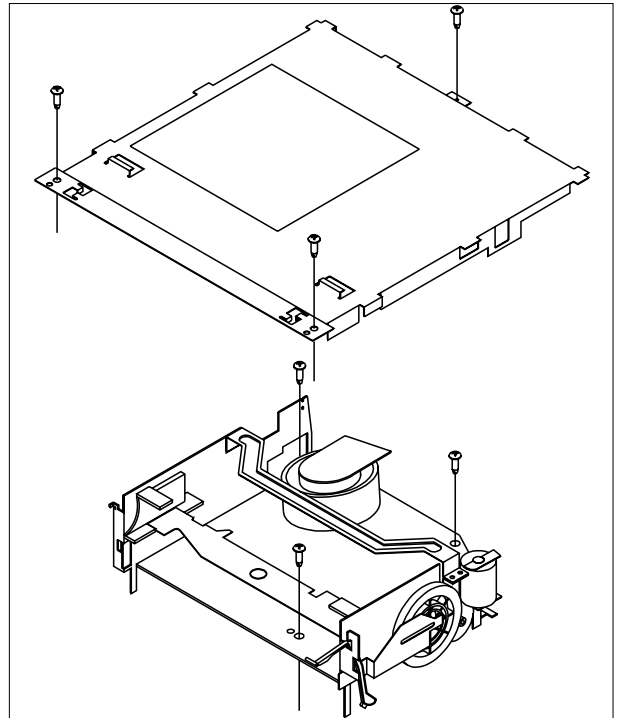

1. Remove 2 screws holding the upper chassis housing.
2. Remove 3 screws holding the deck assembly.
3. Lift the deck assembly upward to remove.

### 3-1-6 Top Cabinet Removal

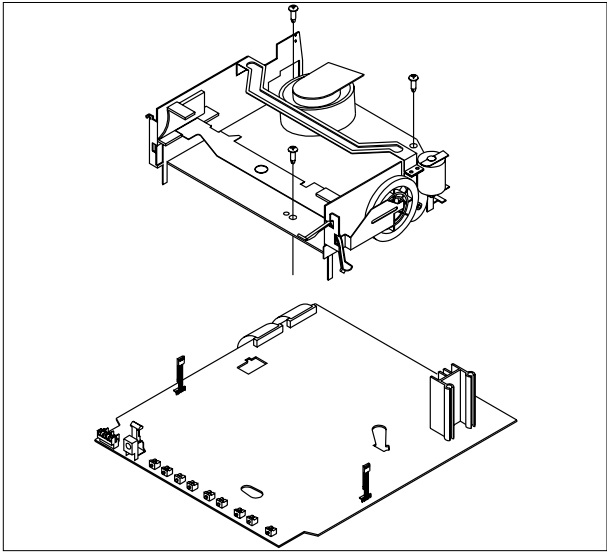

- 1. Remove two (2) screws located at the rear of the top cabinet.
- 2. Carefully lift the back of the top cabinet and shield it to the rear to remove.

### 3-1-7 Top Cabinet Removal

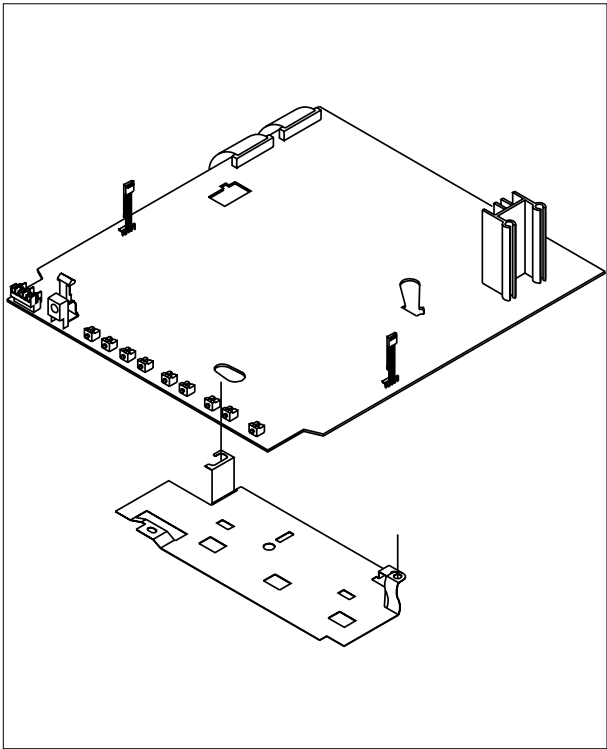

### 3-1-8 Top Cabinet Removal

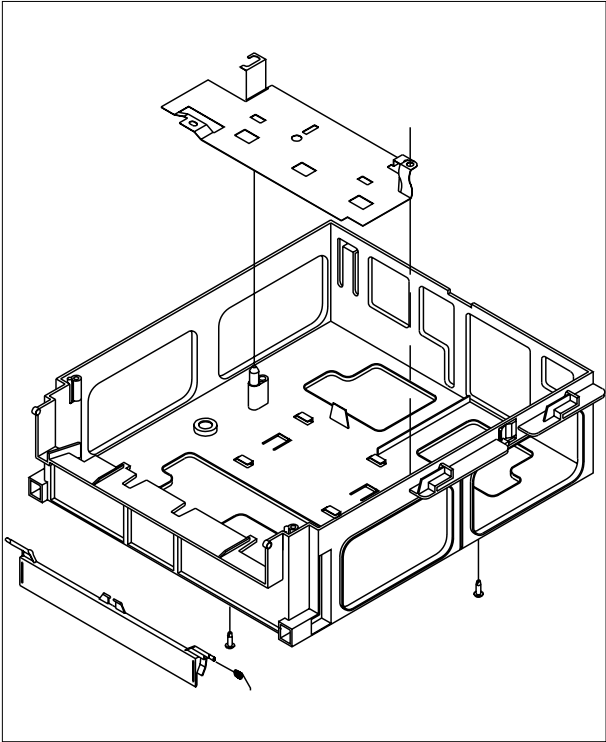

---

## 4. Alignments and Adjustments (Mechanical)

---

### 4-1 Deck Parts Locations

---

#### 4-1-1 Deck (Top View)

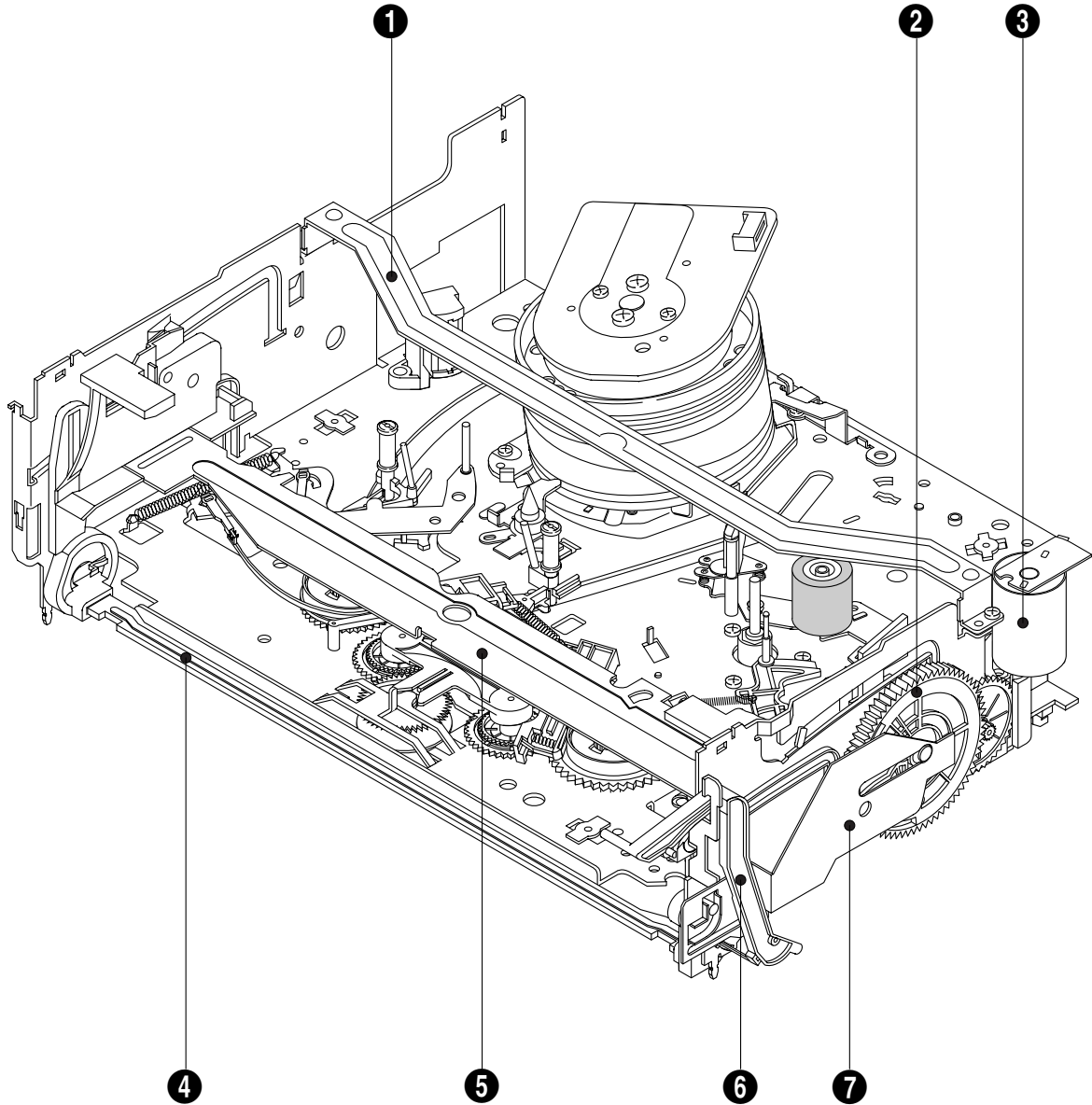

Fig. 4-1 Top parts Location-1

- ❶ BRACKET FL TOP
- ❷ GEAR FL CAM
- ❸ MOTOR LOADING ASS'Y
- ❹ LEVER FL ARM ASS'Y
- ❺ HOLDER FL CASSETTE ASS'Y
- ❻ LEVER FL DOOR
- ❼ SLIDER FL DRIVE

### 4-1-2 Deck (Top View)

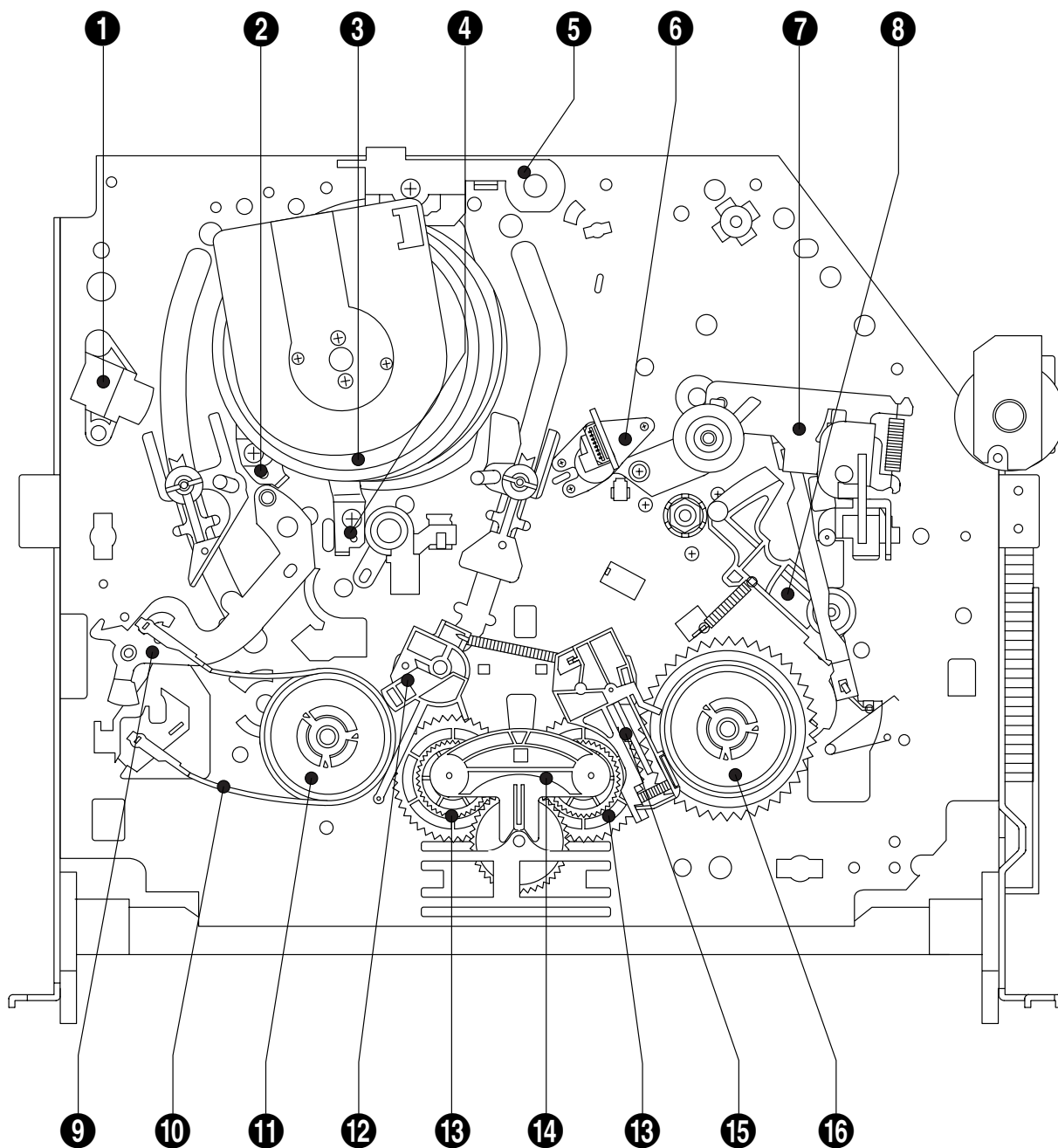

Fig. 4-2 Top Parts Location-2

- |                        |                       |
|------------------------|-----------------------|
| ① FE HEAD              | ⑩ BAND BRAKE ASS'Y    |
| ② PLATE CYLINDER C     | ⑪ DISK S REEL         |
| ③ CYLINDER ASS'Y       | ⑫ LEVER S BRAKE ASS'Y |
| ④ PLATE CYLINDER B     | ⑬ GEAR IDLE           |
| ⑤ PLATE CYLINDER A     | ⑭ LEVER IDLE          |
| ⑥ ACE HEAD ASS'Y       | ⑮ LEVER T BRAKE ASS'Y |
| ⑦ UNIT PINCH ASS'Y     | ⑯ DISK T REEL         |
| ⑧ LEVER #9 GUIDE ASS'Y |                       |
| ⑨ LEVER TENSION ASS'Y  |                       |

## 4-1-3 Deck (Bottom View)

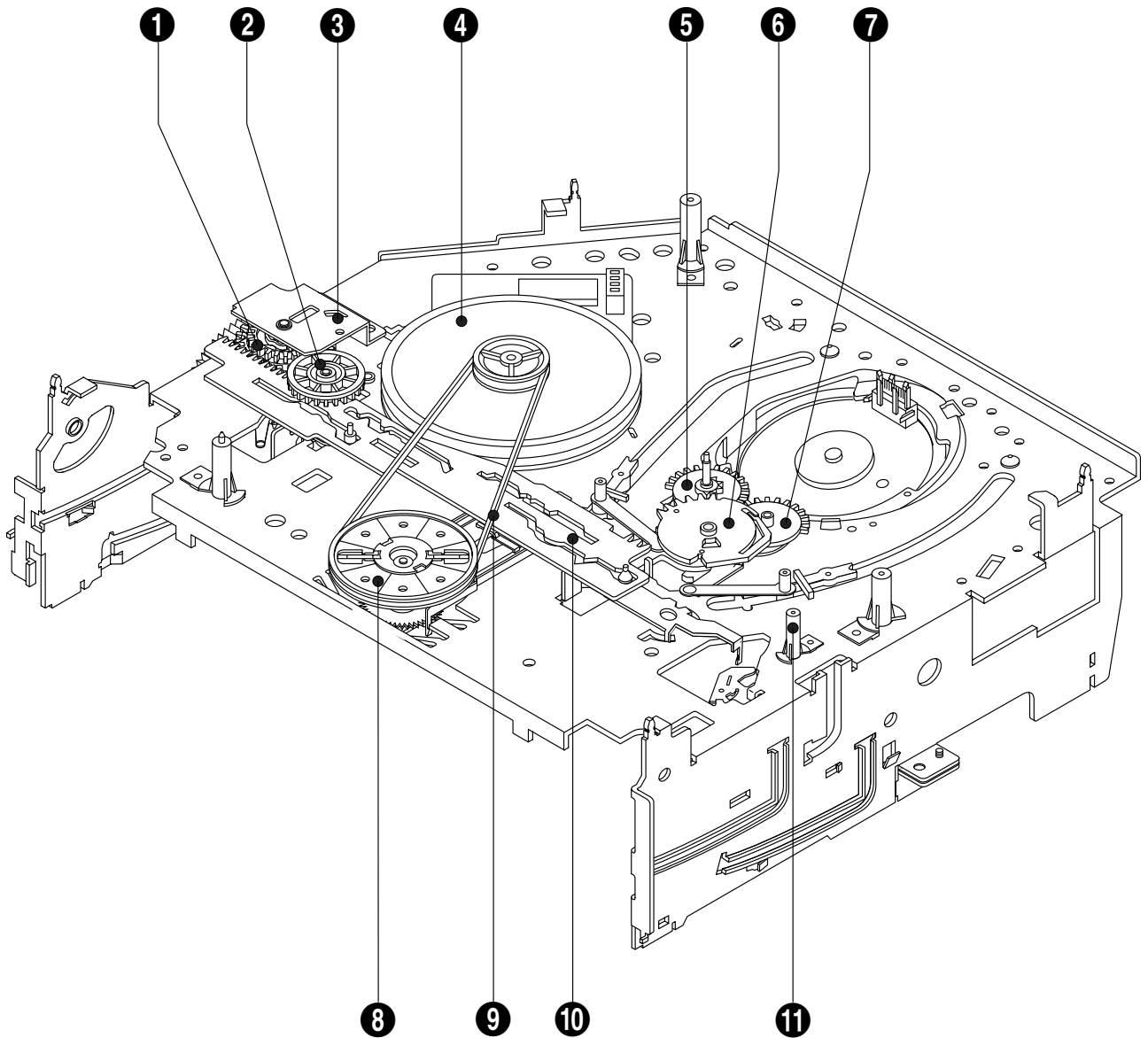

Fig. 4-3 Bottom Parts Location

- |                       |                       |
|-----------------------|-----------------------|
| ① GEAR JOINT 1        | ⑧ HOLDER CLUTCH ASS'Y |
| ② GEAR JOINT 2        | ⑨ BELT PULLEY         |
| ③ BRACKET GEAR        | ⑩ SLIDER CAM          |
| ④ MOTOR CAPSTAN ASS'Y | ⑪ SLEEVE TENSION      |
| ⑤ LEVER T LOAD ASS'Y  |                       |
| ⑥ GEAR LOADING DRIVE  |                       |
| ⑦ LEVER S LOAD ASS'Y  |                       |

## 4-2 Main Deck

### 4-2-1 Bracket FL Top Removal

1. Remove 2 screws ❶.
2. Remove the Bracket FL Top ❷.

**Note :** Take care not to change assembly direction.

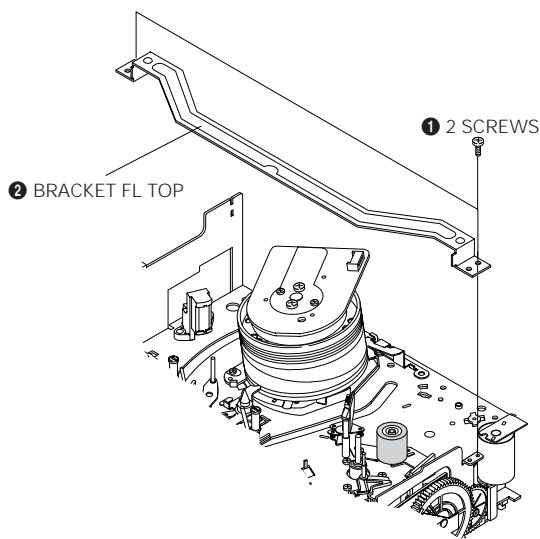

Fig. 4-4 Braket FL Top Removal

### 4-2-2 Lever FL Door Removal

1. Rotate the Lever FL Door ❶ in the direction of arrow "A".
2. Release the Hook ❷, remove the Lever FL Door ❶ in the direction of arrow "B".

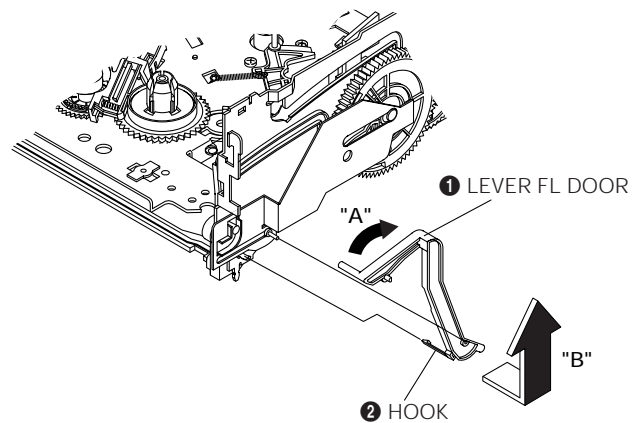

Fig. 4-5 Lever FL Door Removal

### 4-2-3 Holder FL Cassette Ass'y Removal

1. Remove the Lever FL Door. (Refer to Fig. 4-5)
2. Pull the Holder FL Cassette Ass'y ❶ to the eject position.
3. Pull the Holder FL Cassette Ass'y ❶ as grasping the Holder FL Cassette Ass'y ❶ and Lever FL Cassette-R ❷ in the same time to release hooking from Main Base until the Boss [A], [B] of Holder FL Cassette Ass'y ❶ is taken out from the Rail [C], [D].
4. Lift the Holder FL Cassette Ass'y ❶ in the direction of arrow "B" in this time, you have to grasp the Lever FL Cassette-R ❷ continuously until the Holder FL Cassette Ass'y ❶ is taken out completely.

**Note :** Be sure to insert Lever FL Cassette-R ❷ in the direction of "A" to prevent separation and breakage of the Lever FL Cassette-R ❷ at disassembling and reassembling.

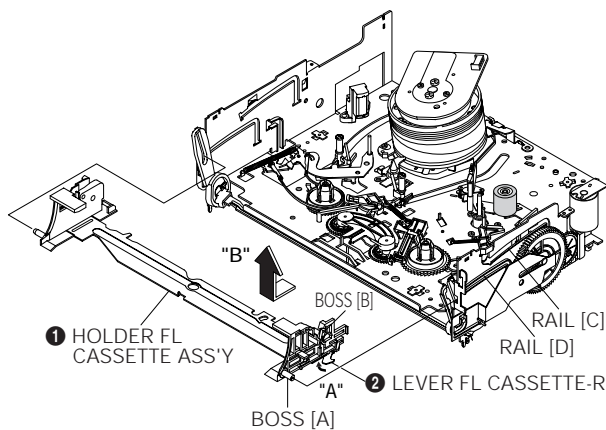

Fig. 4-6 Holder FL Cassette Ass'y Removal

### 4-2-4 Lever FL Arm Ass'y Removal

1. Remove the Lever FL Door. (Refer to Fig. 4-5)
2. Remove the Holder FL Cassette Ass'y. (Refer to Fig.4-6)
3. Release the Hook ❶ in the direction of arrow "A", pull out the Lever FL Arm Ass'y ❷ from the Boss of Main Base.
4. Remove the Lever FL Arm Ass'y ❷ in the direction of arrow "B".

**Assembly :** When reinstalling, be sure to reassemble Lever FL Arm Ass'y ❷ after you insert the Boss ❷ in Groove [A] of Slider FL Drive ❸.

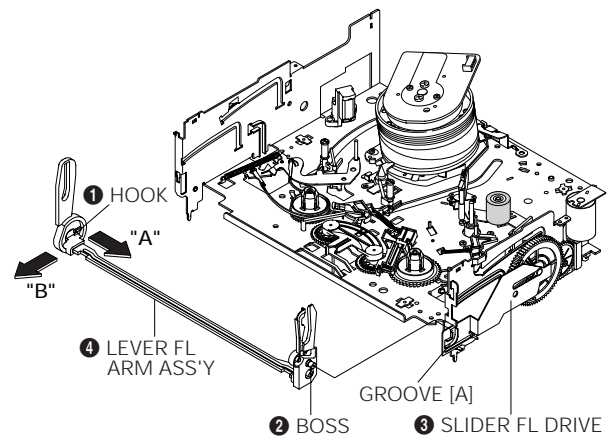

Fig. 4-7 Lever FL Arm Ass'y Removal

### 4-2-5 Slider FL Drive Removal

1. Pull the Slider FL Drive **1** to the front direction.
2. Remove the Slider FL Drive **1** in the direction of arrow. (Refer to Fig. 4-8)

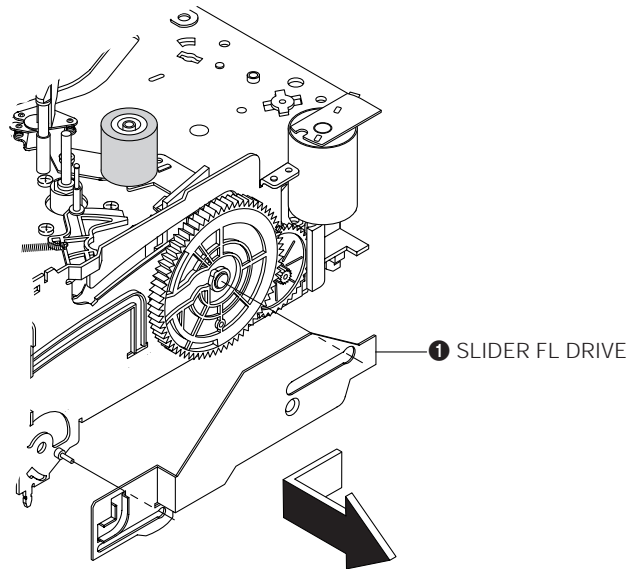

Fig. 4-8 Slider FL Drive Removal

### 4-2-6 Bracket Gear, Gear FL Cam, Gear Joint 1, 2 Removal

1. Remove screw **1**.
2. Lift the Bracket Gear **2**.
3. Remove the Gear FL Cam **3**.
4. Lift the Gear Joint 2 **4**, Gear Joint 1 **5**.

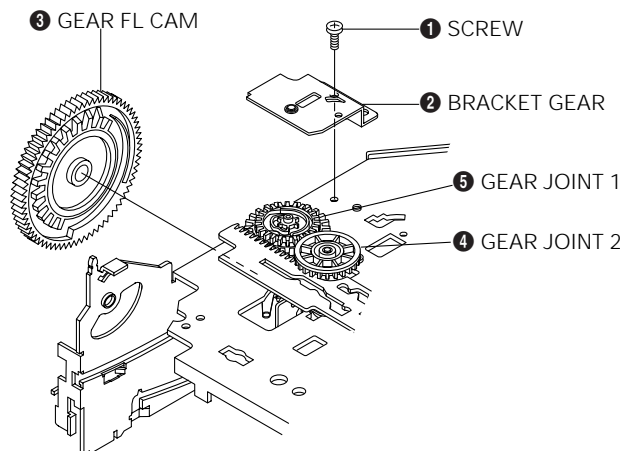

Fig. 1-9 Bracket Gear, Gear FL Cam, Gear Joint 1, 2 Removal

#### 4-2-7 Assembly of Gear FL Cam, Gear Joint 1, 2

1. Be sure to align dot mark of Gear Joint 1 ❶ with dot mark of Gear Joint 2 ❷ as shown Fig. 4-10 (Refer to Timing Point 1), confirm the Timing Point 2 of the Gear Joint 2 ❷ and Slider Cam ❸.
2. Align the Gear FL Cam ❹ with the Gear Worm Wheel Post as shown detail drawing. (Refer to Timing Point 3)

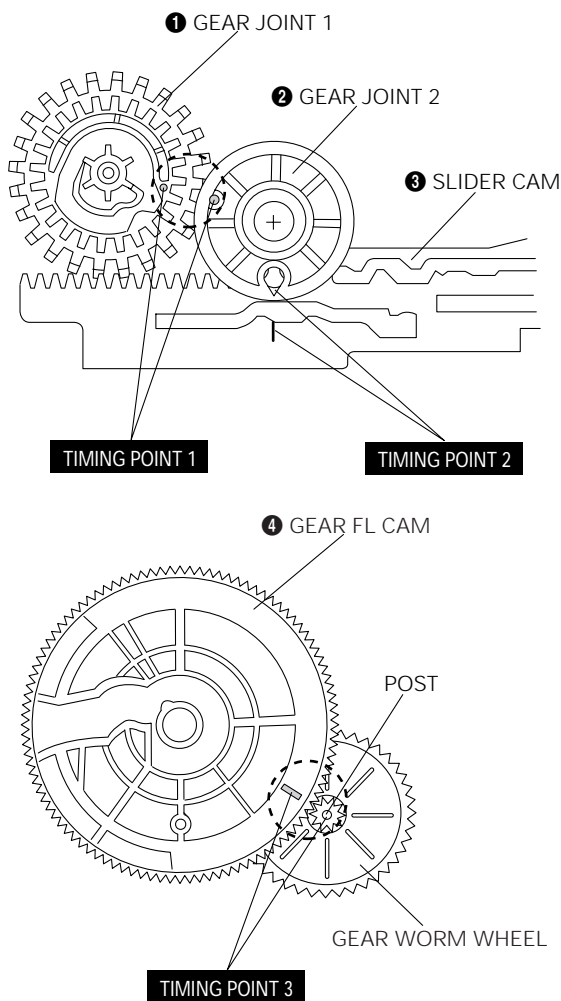

Fig. 4-10 Assembly of Gear FL Cam, Gear Joint 1, 2

#### 4-2-8 Holder Worm, Gear Worm, Gear Worm Wheel Removal

1. Release the Hook [A] in the direction of arrow and, remove the Holder Worm ❶.
2. Remove the Gear Worm ❷.
3. Remove the Gear Worm Wheel ❸. (After removing the Gear FL Cam as shown Fig. 4-9)

**Note :** Secure the Hook [A] after installing the Holder Worm ❶.

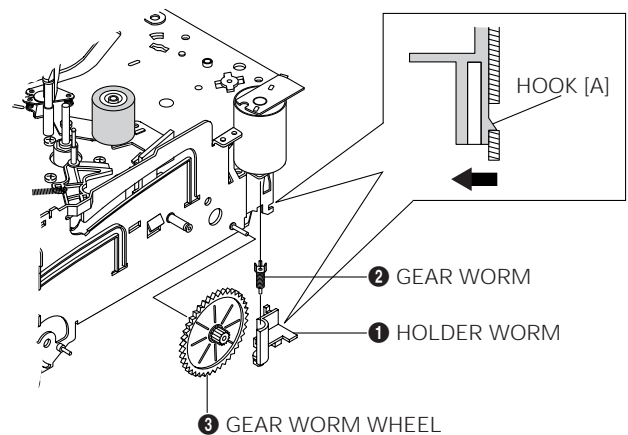

Fig. 4-11 Holder Worm, Gear Worm, Gear Worm Wheel removal

### 4-2-9 Motor Loading Ass'y Removal

1. Remove the screw ❶.
2. Remove the Motor Loading Ass'y ❷.

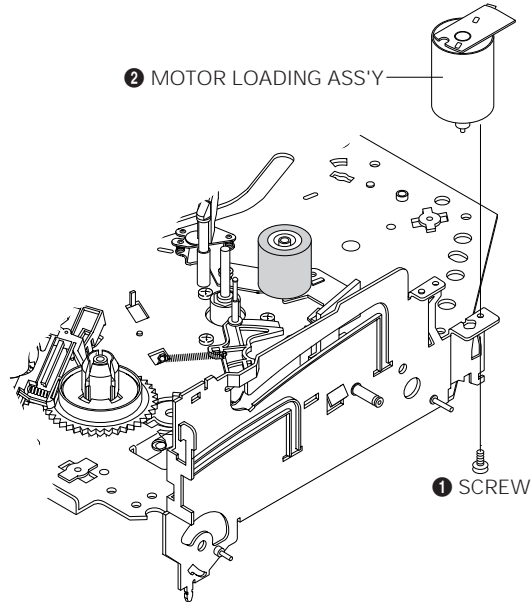

Fig. 4-12 Motor Loading Ass'y Removal

### 4-2-10 Gear Loading Drive, Slider Cam, Lever T, S Load Ass'y Removal

1. Remove the Belt Pulley. (Refer to Fig. 4-29)
2. Remove the Gear Loading Drive ❶ after releasing Hook [A] in the direction arrow as shown in detail drawing.
3. Remove the Slider Cam ❷.
4. Remove the Lever T, S Load Ass'y ❸, ❹.

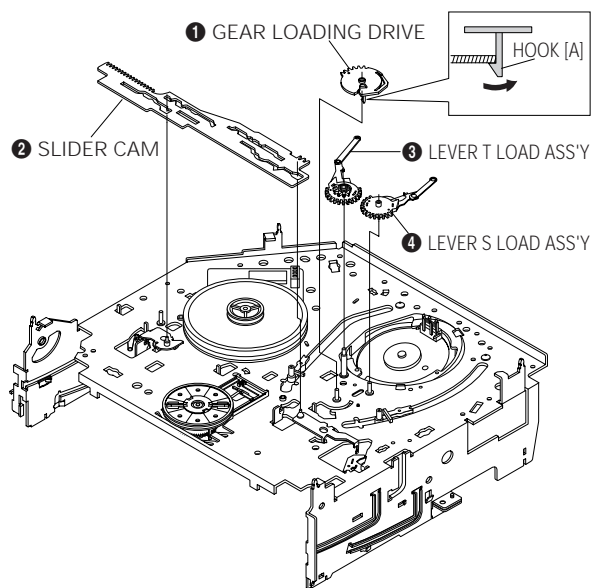

Fig. 4-13 Gear Loading Drive, Slider Cam, Lever T, S Load Ass'y Removal

#### 4-2-11 Assembly of Gear Loading Drive, Slider Cam, Lever T, S Load Ass'y

1. When reinstalling, be sure to align dot of Lever T Load Ass'y ① with dot of Lever S Load Ass'y ② as shown in drawing. (Refer to Timing Point 1)
2. Insert the Pin A, B, C, D into the Slider Cam ③ hole.
3. Be sure to align dot of Lever T Load Ass'y and dot of Gear Loading Drive ④. (Refer to Timing Point 2)
4. Align dot of Gear Loading Drive with mark of Slider Cam as shown in drawing. (Refer to Timing Point 3)

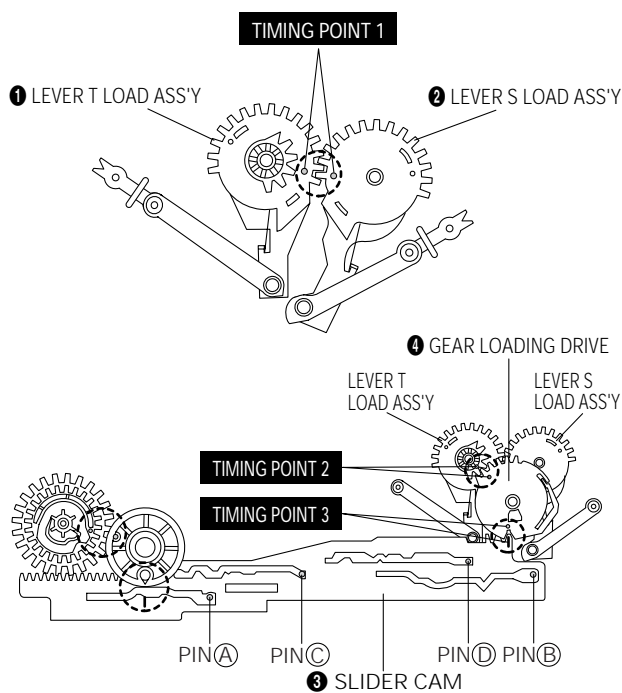

Fig. 4-14 Assembly of Gear Loading Drive, Slider Cam, Lever T, S Load Ass'y

#### 4-2-12 Lever Tension Ass'y, Band Brake Ass'y, Sleeve Tension Removal

1. Remove the Spring Tension ①.
2. In bottom side of Deck, remove the Sleeve Tension ② after rotating it right or left as lifting locking edge of Sleeve Tension.
3. Remove the side "a" of the Band Brake Ass'y ④ in the direction of arrow "A" from the Lever Tension Ass'y ③.
4. Remove the side "b" of the Band Brake Ass'y ④ in the direction of arrow "B" from the Main Base.

##### Note :

1. When replacing the Lever Tension Ass'y, be sure to apply oil in the Sleeve Tension.
2. Take care not to touch stain on the felt side, and not to be folded and broken Band Brake Ass'y.

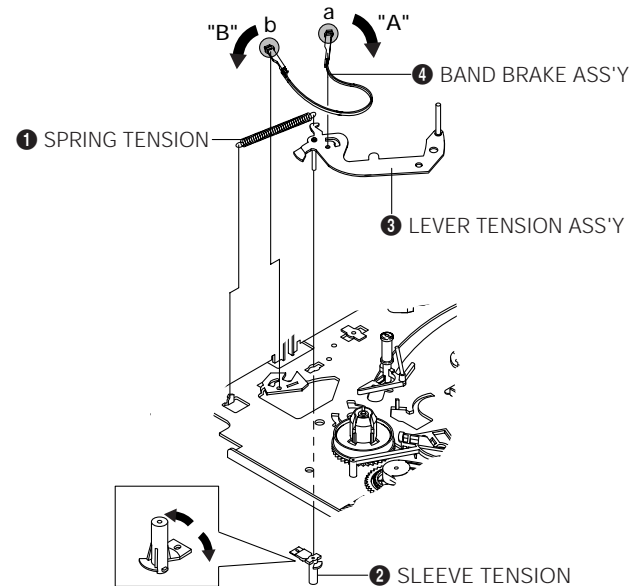

Fig. 4-15 Lever Tension Ass'y, Band Brake Ass'y, Sleeve Tension Removal

### 4-2-13 Lever S, T Brake Ass'y Removal

1. Release the Hook [A] and the Hook [B], [C] in the direction of arrow as shown in Fig. 1-16.
2. Lift the Lever S, T Brake Ass'y ❶, ❷ with Spring Brake ❸.

**Assembly :**

1. Assemble the Lever S Brake Ass'y ❶ on the Main Base.
2. Assemble the Lever T Brake Ass'y ❷ with Spring Brake ❸.

**Note :** Take extreme care not to folded or transform the spring Brake while removing or reinstalling.

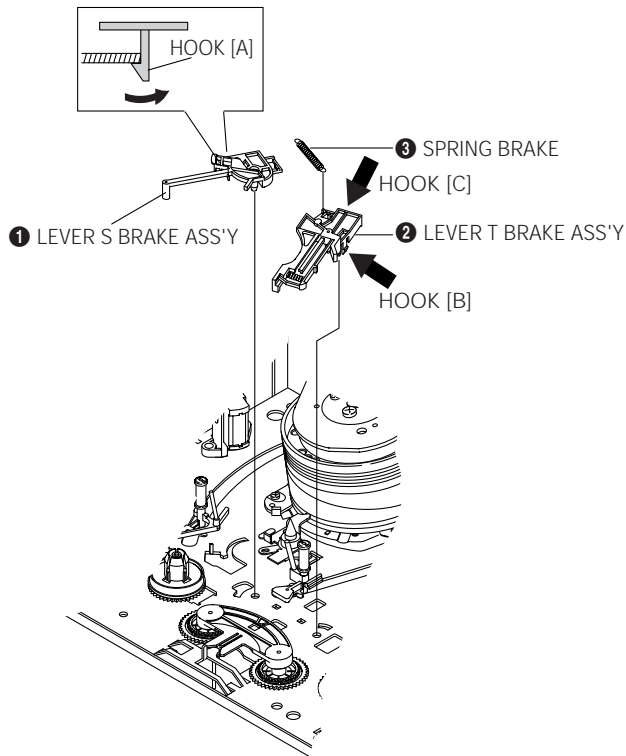

Fig. 4-16 Lever S, T Brake Ass'y Removal

### 4-2-14 Lever Idle Ass'y Removal

1. Push the Lever Idle ❶ in the direction of arrow "A", "B".
2. Lift the Lever Idle ❶.

**Assembly :**

1. Apply oil in two Bosses of Lever Idle ❶.
2. Assemble the Gear Idle ❷ with the Lever Idle ❶.

**Note :** When replacing the Gear Idle ❷, be sure to add oil in the boss of Lever Idle ❶.

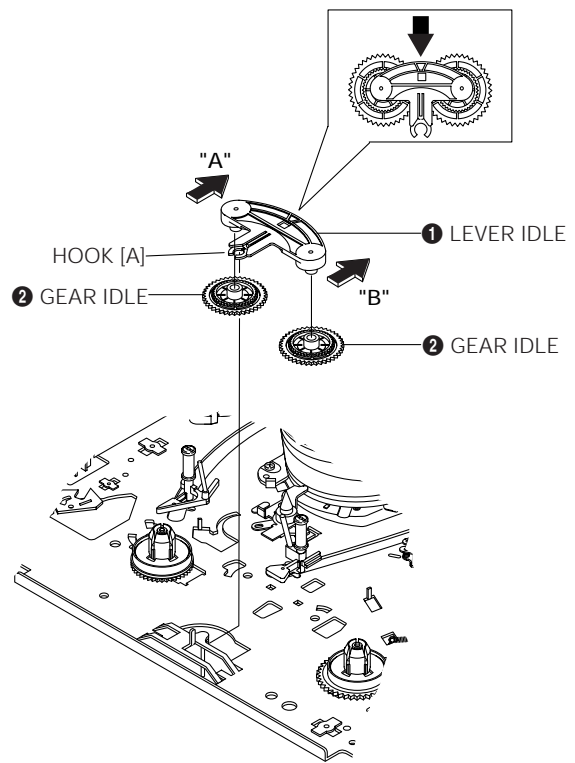

Fig. 4-17 Lever Idle Ass'y Removal

#### 4-2-15 Disk S, T Reel Removal

1. Lift the Disk S, T Reel ❶, ❷.

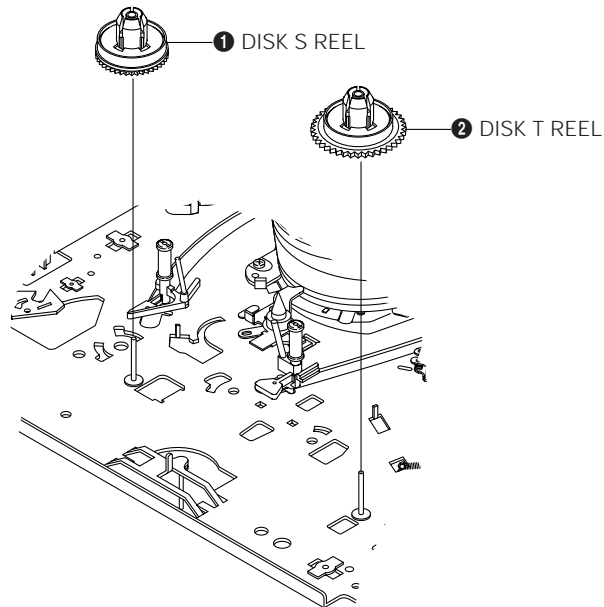

Fig. 4-18 Disk S, T Reel Removal

#### 4-2-16 Holder Clutch Ass'y Removal

1. Remove the Washer Slit ❶.
2. Lift the Holder Clutch Ass'y ❷.

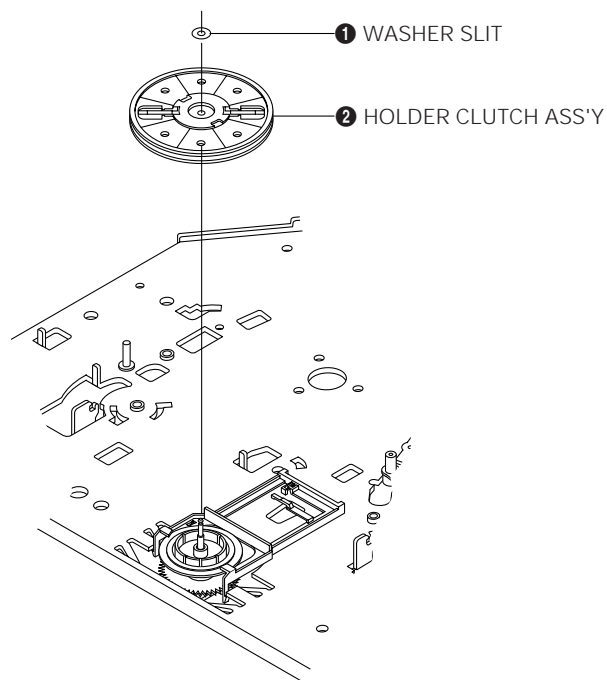

Fig. 4-19 Holder Clutch Ass'y Removal

#### 4-2-17 Lever Up Down Ass'y, Gear Center Ass'y Removal

1. Remove the 2 hooks in the direction of arrow as shown Fig. 1-20 and lift the Lever Up Down Ass'y **1**.
2. Lift the Gear Center Ass'y **2**.

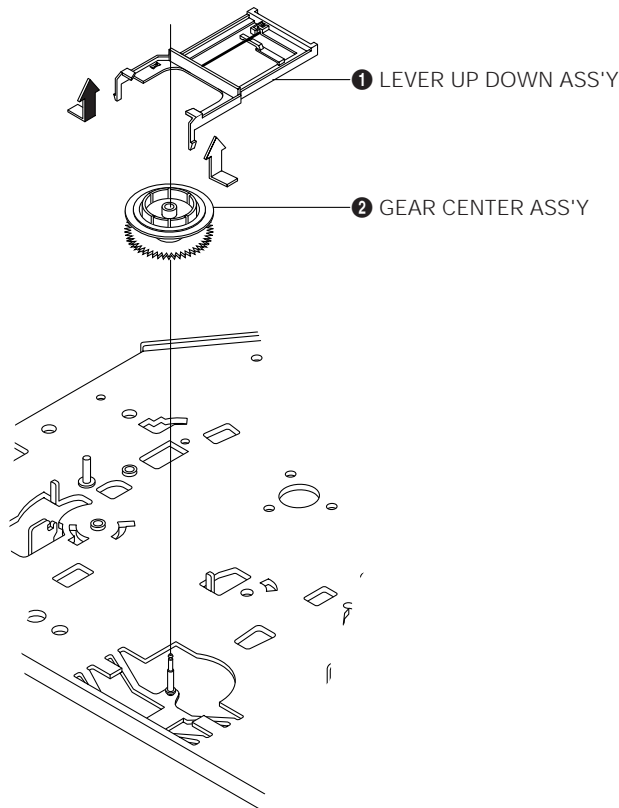

Fig. 4-20 Lever Up Down Ass'y, Gear Center Ass'y Removal

#### 4-2-18 Assembly of Lever Up Down Ass'y, Gear Center Ass'y

1. Insert the Lever Up Down Ass'y **1** in the 2 rectangular holes on Main Base.
2. Lift the Lever Up Down Ass'y **1** about 35 degree. (Refer to Fig. 1-21)
3. Insert Ring **4** of the Gear Center Ass'y **2** in the Guide **5** of the Lever Up Down Ass'y **1**.
4. Insert the Gear Center Ass'y **2** in the post **6** on Main Base.
5. Push down the Lever Up Down Ass'y **1** for locking of the Hook **7**.

**Note :**

1. Take care not to separate and loose the Spring Up Down.
2. When assembling the Gear Center Ass'y, don't push down too much.

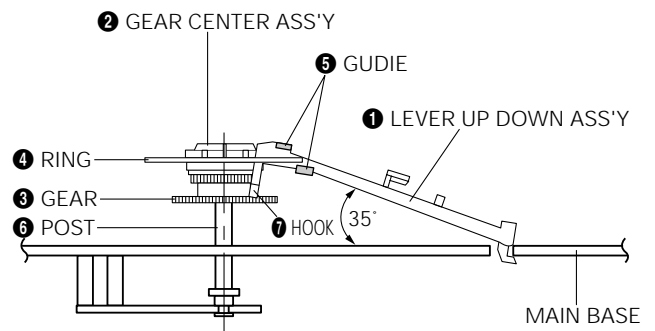

Fig. 4-21 Assembly of Lever Up Down Ass'y, Gear Center Ass'y

#### 4-2-19 Guide Cassette Door Removal

1. Lift the Hook [A].
2. Rotate the Guide Cassette Door ❶ in the direction of arrow.

**Note :** After reinstalling the Guide Cassette Door ❶ secure the Hook [A].

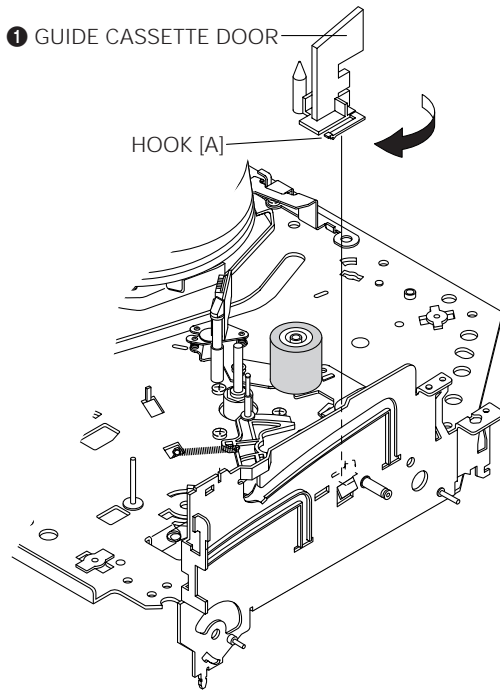

Fig. 4-22 Guide Cassette Door Removal

#### 4-2-20 Unit Pinch Ass'y, Plate Joint, Spring Pinch Drive Removal

1. Lift the Unit Pinch Ass'y ❶.
2. Remove the Plate Joint ❷ from Lever Pinch Drive.
3. Remove the Spring Pinch Drive ❸.

**Note :**

1. Take extreme care not to touch the grease on the Roller Pinch.
2. When reinstalling, be sure to apply grease on the post pinch roller.

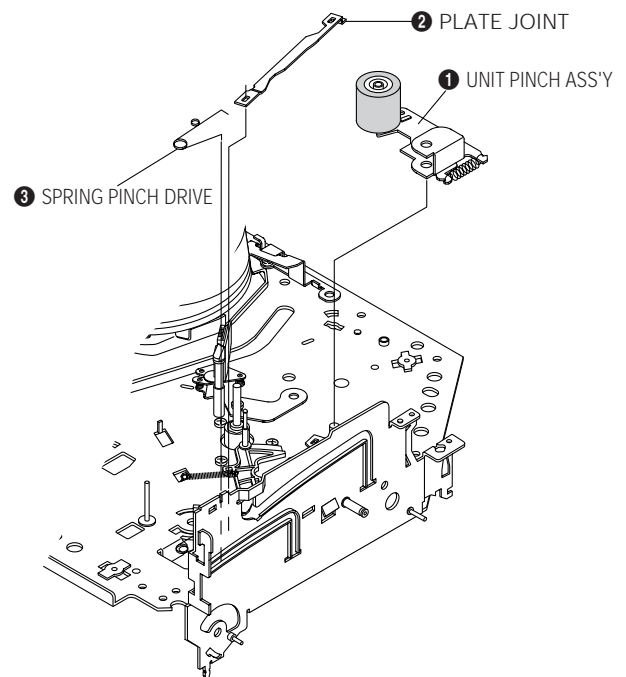

Fig. 4-23 Unit Pinch Ass'y, Plate Joint, Spring Pinch Drive Removal

#### 4-2-21 Lever #9 Guide Ass'y Removal

1. Remove the Spring #9 Guide ❶.
2. Lift the Lever #9 Guide Ass'y ❷ in the direction of arrow.

**Note :**

1. Take extreme care not to touch the grease on the tape Guide Post.
2. After reinstalling, check the bottom side of the Post #9 Guide to stick to the top side of Main Base.

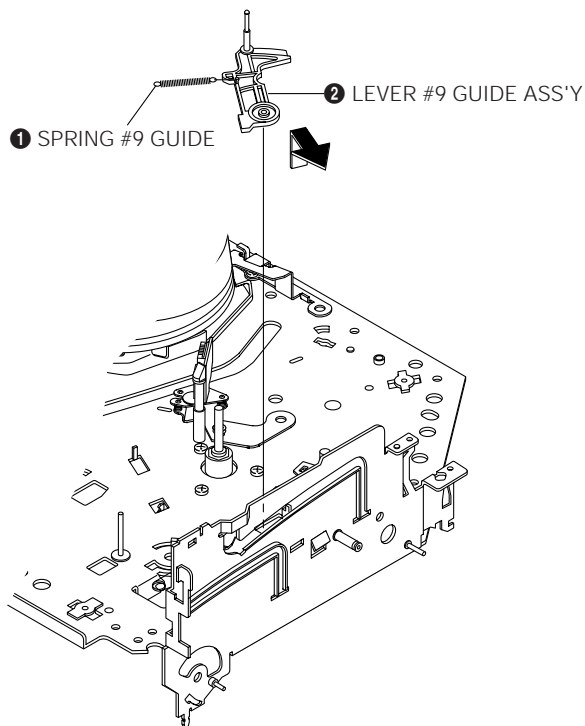

Fig. 4-24 Lever #9 Guide Ass'y Removal

#### 4-2-22 FE Head Removal

1. Remove the screw ❶.
2. Lift the FE Head ❷.

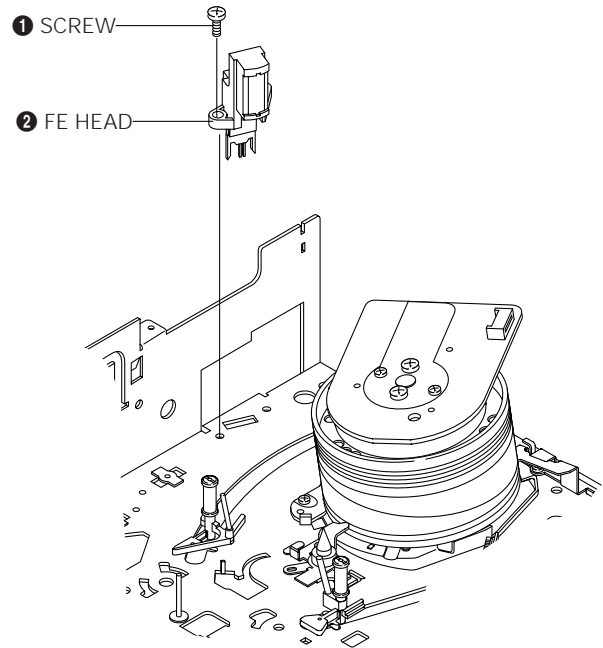

Fig. 4-25 FE Head Removal

### 4-2-23 ACE Head Removal

1. Pull out the FPC from connector of ACE Head Ass'y ②.
2. Remove the screw ①.
3. Lift the ACE Head Ass'y ②.

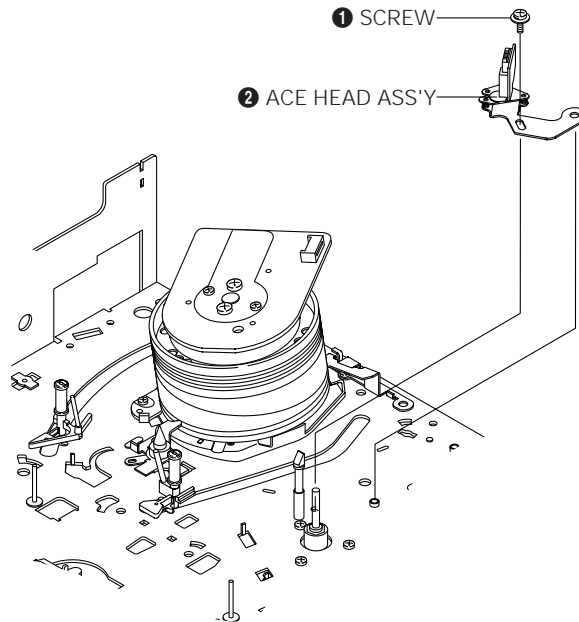

Fig. 4-26 ACE Head Removal

### 4-2-24 Slider S, T Ass'y Removal

1. Move the Slider S, T Ass'y ①, ② to slot, and then lift it to remove. (Refer to arrow)

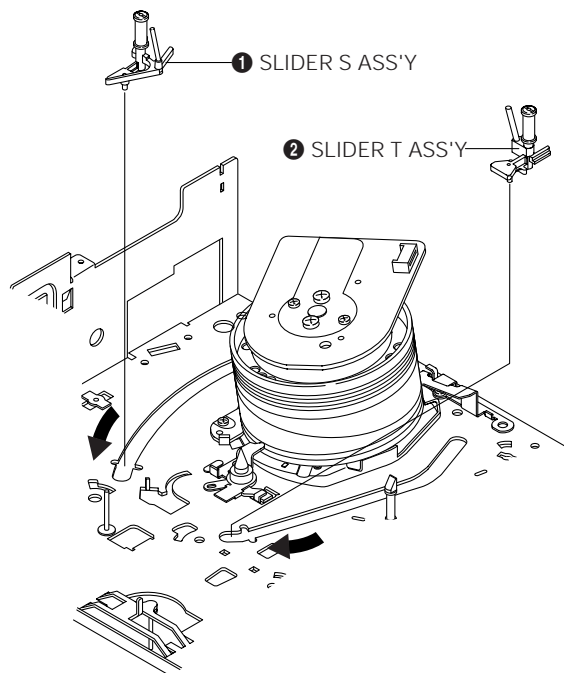

Fig. 4-27 Slider S, T Ass'y Removal

### 4-2-25 Cylinder Ass'y Removal

1. Remove the 3 Screws ❶, ❸, ❺.
2. Remove the Plate Cylinder A, B, C ❷, ❹, ❻ in the direction of arrow.
3. Lift the Cylinder Ass'y ❷.

**Note :**

1. When reinstalling, push the Plate Cylinder A, B ❹, ❻ in the reverse of arrow and then, tighten the 2 Screws ❸, ❺.
2. Take care not to touch the Cylinder Ass'y and the tape guide post at reinstalling Plate Cylinder C ❷.
3. Take care not to touch the Cylinder Ass'y with screw driver at reinstalling the Plate Cylinder C ❷.

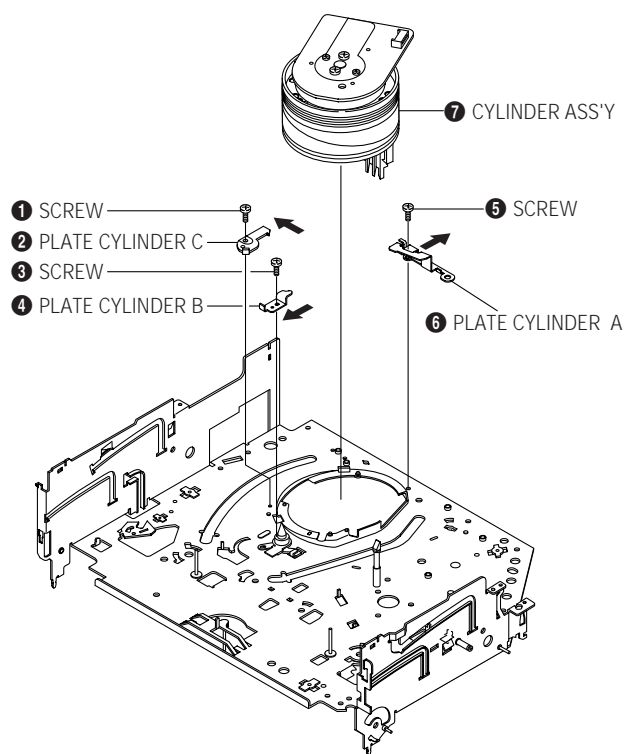

Fig. 4-28 Cylinder Ass'y Removal

### 4-2-26 Belt Pulley Removal

1. Remove the Belt Pulley ❶.

**Note :** Take extreme care not to touch the grease on Belt Pulley ❶ at assembling or reassembling.

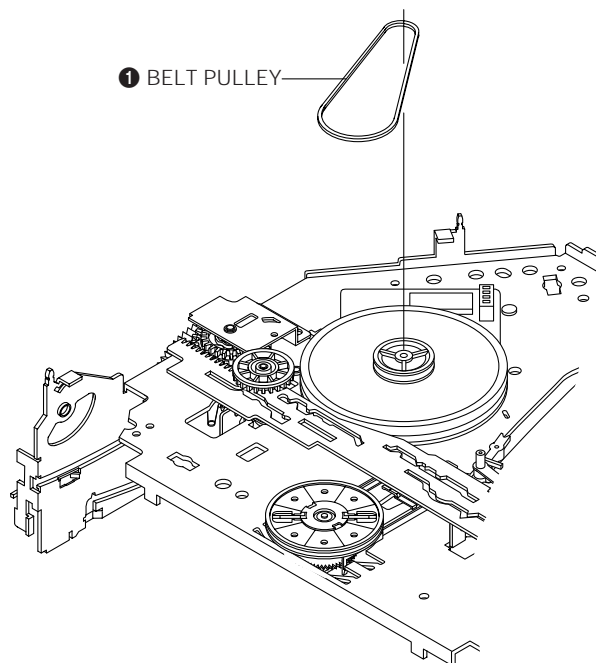

Fig. 1-29 Belt Pulley Removal

### 4-2-27 Lever Head Cleaner Ass'y Removal (Optional)

1. Release the Hook ❶.
2. Lift the Lever Head Cleaner Ass'y ❷.

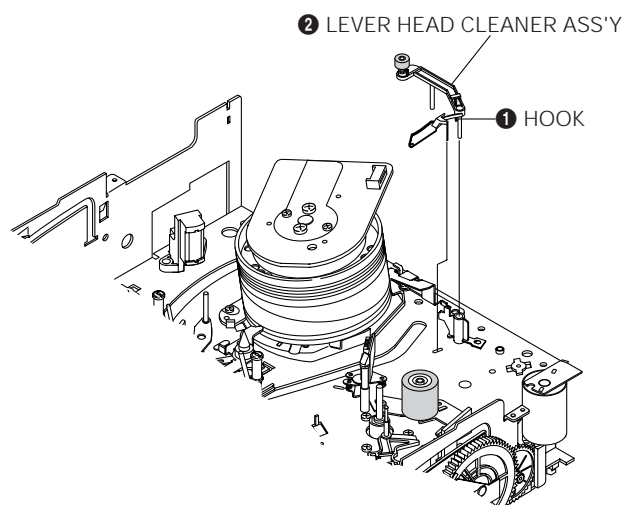

Fig. 4-30 Lever Head Cleaner Ass'y Removal

#### 4-2-28 Motor Capstan Ass'y Removal

1. Remove the 3 Screws ❶.
2. Remove the Motor Capstan Ass'y ❷.

##### Assembly :

1. Match the 3 holes of Motor Capstan Ass'y ❷ to the 3 holes of Main Base as attending not to drop or knock the Motor Capstan Ass'y.
2. Tighten the 3 Screws in the direction of arrow as shown detail drawing.

##### Note :

1. Don't reuse the removed screws from Motor Capstan Ass'y.
2. After tightening screws, check if there is gap between the head of screws and the top side of Main Base. There should have no gap between the head of screws and the top side of Main Base.
3. After reinstalling, adjusting the tape transport system again.

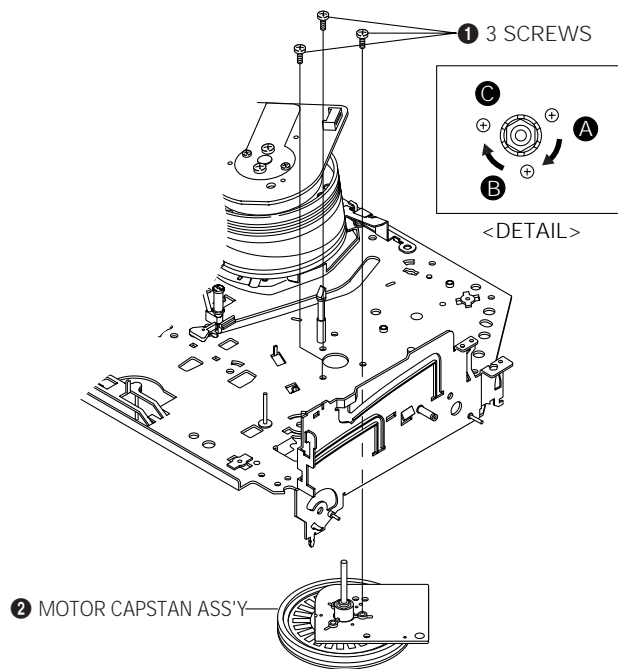

Fig. 4-31 Motor Capstan Ass'y Removal

#### 4-2-29 How to Manually Eject the Cassette Tape

1. Remove the Holder worm ❶ and the Gear Worm ❷.
2. Turn the Gear Worm Wheel ❸ counterclockwise with screw driver. (Refer to arrow)

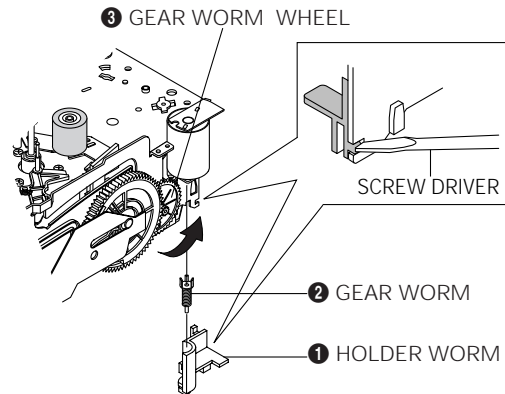

Fig. 4-32

3. As Sliders S and T are approached in the unloading position, rotate holder Clutch counterclockwise after inserting screw driver in the hole of frame's bottom (in order to wind the unwinded tape). (Refer to Fig. 4-33)

If you rotate Gear Worm Wheel continuously when tape is unwinding, you may cause tape contamination by grease and tape damage. Be sure to wind horizontally.

4. Rotate Gear Worm Wheel ❸ counterclockwise using screw driver, up to the state of eject mode, and then pick out the tape. (Refer to Fig. 4-32)

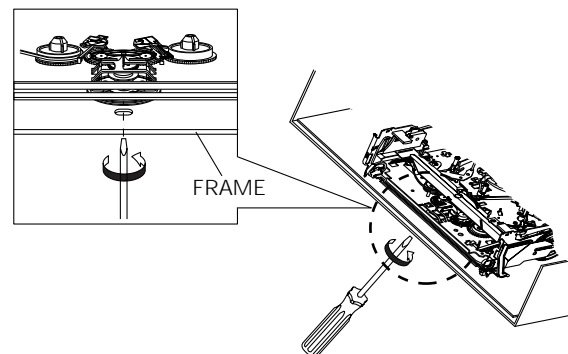

Fig. 4-33

### 4-3 Lubrication and recommended replacement time for principal parts

1. The recommended replacement time is shorter than the design maximum.
2. Table 1-1 assumes VCR is in normal environment (normal temperature, normal humidity).  
The checking period may be changed based on the manner of use, runtime and environmental conditions.
3. Life of the Cylinder Ass'y depends on the manner of use.
4. See exploded view for location of each part.

<Table 1-1>

*	Parts Name	Checking Period										Remark
		500	1000	1500	2000	2500	3000	3500	4000	4500	5000	
T A P E  P A T H  S Y S T E M	POST TENSION	Δ	Δ	Δ	Δ	Δ	Δ	Δ	Δ	Δ	Δ	- To clean the parts, use patch and alcohol (solvent).  - After cleaning, use the video tape after alcohol is gone away completely.  - We recommend to use oil [EP-56] or solvent.  - One or two drops of oil should be applied after cleaning with alcohol.  - Periodic time of applying oil (Apply oil after cleaning) - The excessive applying oil may be the cause of malfunction.
	SLANT POST S, T	Δ	Δ	Δ	Δ	Δ	Δ	Δ	Δ	Δ	Δ	
	#8 GUIDE SHAFT	Δ	Δ	Δ	Δ	Δ	Δ	Δ	Δ	Δ	Δ	
	CAPSTAN SHAFT	Δ	Δ	Δ	Δ	Δ	Δ	Δ	Δ	Δ	Δ	
	#9 GUIDE POST	Δ	Δ	Δ	Δ	Δ	Δ	Δ	Δ	Δ	Δ	
	#3 GUIDE POST	Δ	Δ	Δ	Δ	Δ	Δ	Δ	Δ	Δ	Δ	
	GUIDE ROLLER S, T	Δ	Δ	Δ	0	0	0	0	0	0	0	
	CYLINDER ASS'Y	Δ	0	0	0	0	0	0	0	0	0	
	FE HEAD	Δ	Δ	Δ	0	0	0	0	0	0	0	
	ACE HEAD	Δ	0	0	0	0	0	0	0	0	0	
	PINCH ROLLER	Δ	0	0	0	0	0	0	0	0	0	
	POST REEL S, T		◆		◆		◆		◆		◆	
	SLEEVE TENSION		◆		◆		◆		◆		◆	
	POST CENTER		◆		◆		◆		◆		◆	
LEVER IDLE BOSS (2Point)		◆		◆		◆		◆		◆		
D R I V I N G	CAPSTAN MOTOR PULLEY	Δ	Δ	Δ	Δ	Δ	0	0	0	0	0	
	BELT PULLEY				0	0	0	0	0	0	0	
	HOLDER CLUTCH ASS'Y	Δ	0	0	0	0	0	0	0	0	0	
	GEAR CENTER ASS'Y		0	0	0	0	0	0	0	0	0	
	GEAR IDLE (2Point)		0	0	0	0	0	0	0	0	0	
	LOADING MOTOR		0	0	0	0	0	0	0	0	0	
B R A K E	BAND BRAKE ASS'Y		0	0	0	0	0	0	0	0	0	
	BRAKE T ASS'Y		0	0	0	0	0	0	0	0	0	

Δ : Cleaning      0 : Check and replacement in necessary      ◆ : Add Oil

## 4-4 Tape Transport System and Adjustment Locations

The tape transport system has been adjusted precisely in the factory. Alignment is not necessary except for the following :

1. Noise observed on the screen.
2. Tape damage.
3. Parts replacement in the tape transport system.

Lower flange height of tape guide is used as the reference for the transport adjustment.

To maintain the height of the tape guide and prevent damage, do not apply excessive force onto the main base.

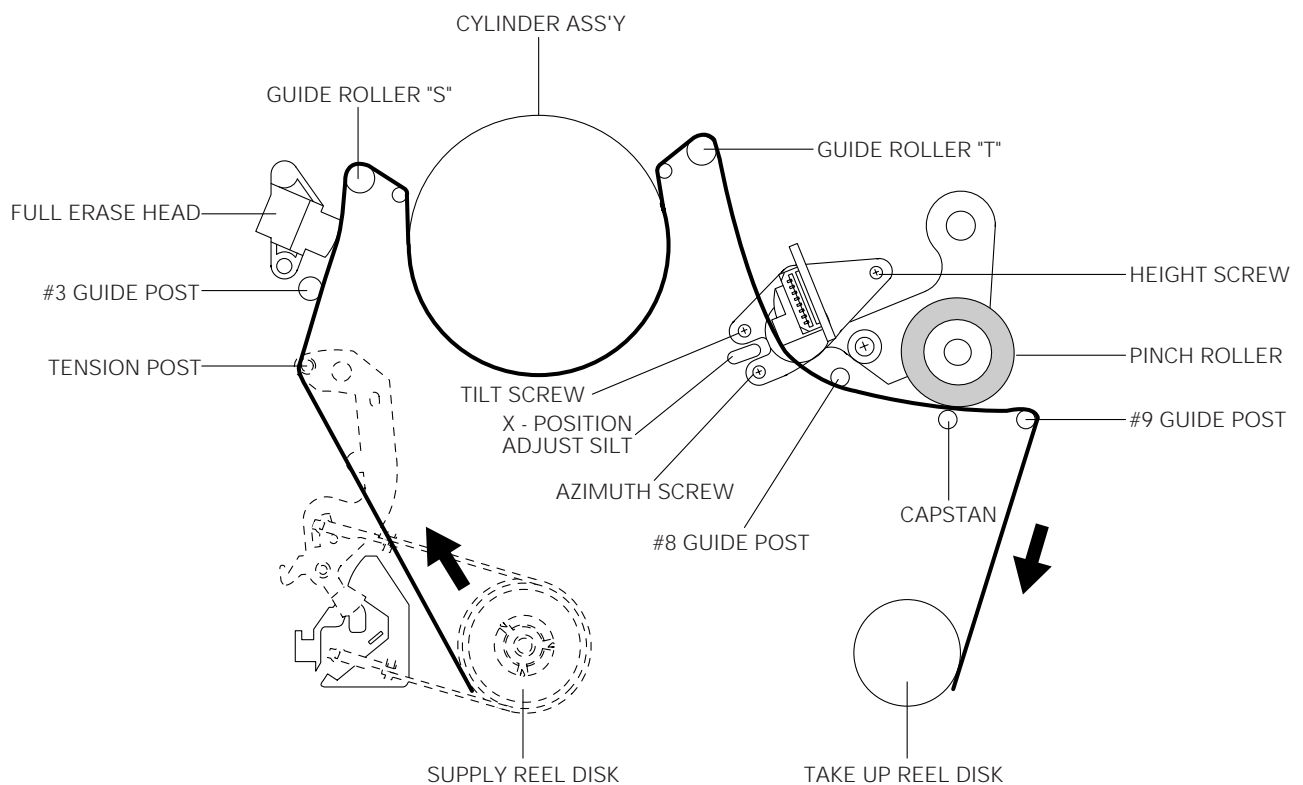

Fig. 4-4-1 Location of Tape Transport Adjustment

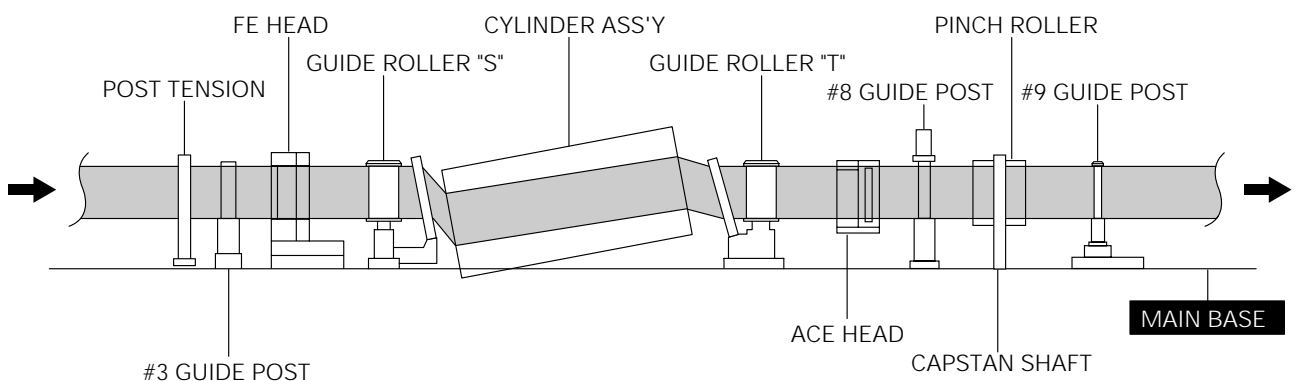

Fig. 4-4-2 Tape Travel Diagram

## 4-5 Tape Transport System Adjustment

When parts are replaced, perform the required adjustments by referring to precedures for the tape transport system. If there are any changes to the tape path, first run a T-120 tape and make sure excessive tape wrinkle does not occur at the tape guides.

1. If tape wrinkle is observed at the guide roller S, T, turn the guide roller S, T until wrinkle disappears.
2. If the tape wrinkle is still observed at the tape guide, perform the tilt adjustment of the ACE head.  
(See page 5-3 of the Service Manual for Test Point Locations.)

### 4-5-1 ACE Head Assembly Adjustment

#### 4-5-1(a) ACE HEAD HEIGHT ADJUSTMENT

1. Run the alignment tape (Color bar) in the playback mode.
2. Observe surface of the audio head using a dental mirror.
3. Turn screw (C) clockwise or counterclockwise until the gap of lower tape edge and the lower edge of the control head is about 0.25mm.  
(Refer to Fig. 4-5-1 and 4-5-2)

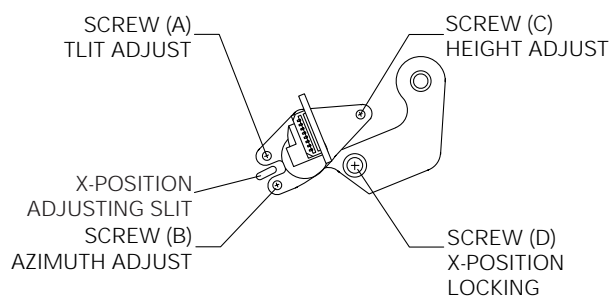

Fig. 4-5-1 Location of ACE Head Adjustment Screw

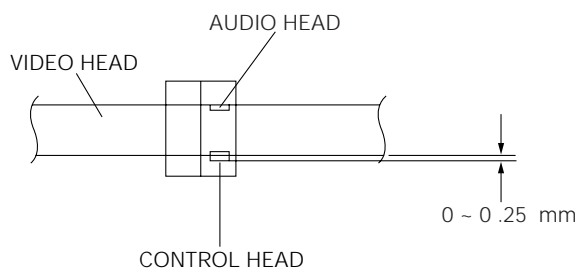

Fig. 4-5-2 ACE Head Height Adjustment

## 4-5-1(b) ACE HEAD TILT ADJUSTMENT

1. Playback a blank T160(E-240) tape and observe the position of the tape at the lower flange of tape guide.
2. Confirm that there is no curl or wrinkle at the lower flange of tape guide (see figure).
3. If a curl or wrinkle of the tape occurs, turn screw "C" slightly clockwise until the wrinkle disappears (see figure).
4. Reconfirm the A/C head height.

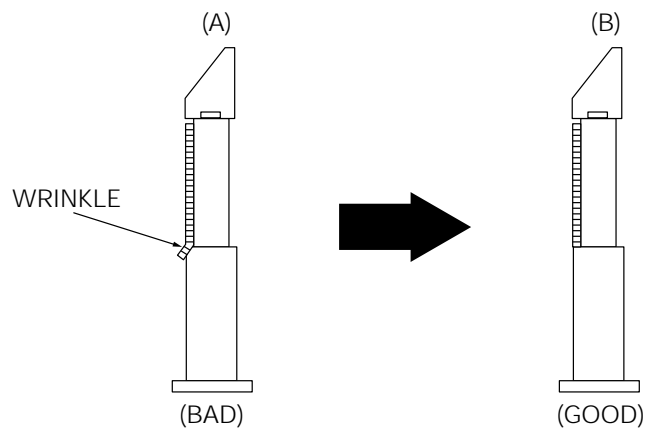

Fig. 4-5-3 Tape Guide Check

## 4-5-1(c) AUDIO AZIMUTH ADJUSTMENT

1. Play back the alignment tape (mono scope).  
(NTSC : 7KHz ; PAL : 6KHz).
2. Connect channel-1 scope probe to audio out on the Main PCB.
3. Adjust screw (B) for maximum audio level.  
(See Fig. 4-5-1)

4-5-1(d) ACE HEAD POSITION (X-POINT)  
ADJUSTMENT (PAL SYSTEM ONLY)

1. On the remote control, press the "1" button and "Input" simultaneously. This will automatically adjust the tracking center.
2. Play back the mono scope alignment tape.
3. Connect Ch1 scope probe to "CTRL" and Ch2 scope probe to "H'D SW". Trigger on the head-switching pulse.
4. Set the tracking preset to 7 msec, and 2H'D to 2 msec. Use the "Fine" tracking buttons ▲ / ▼ on the remote control.
5. Connect Ch1 scope probe to "ENV"; connect Ch-2 to "H'D SW" and trigger on Ch-1.
6. Insert the adjusting gear. Adjust the driver in either direction for maximum envelope wave form.
7. Note: Since the adjusting gear unit may be damaged, do not adjust X-point by using force. After turning the X-point adjusting screw (D) slightly counterclockwise, perform the adjustment and then tighten the screw.

## ◆ Setting of Scope ◆

-Volt/div. ; CH-1 = 0.1V  
CH-2 = 0.2V

-Time/div. ; 5msec

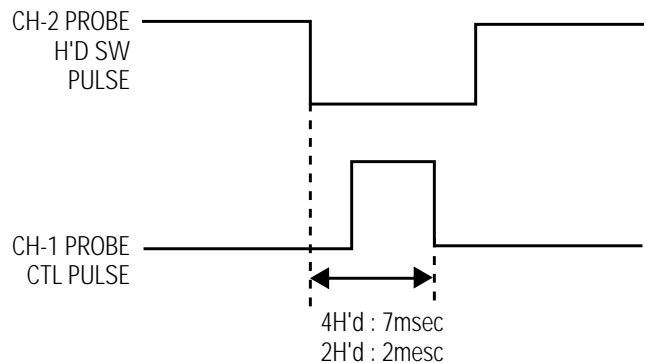

Fig. 4-5-4 Tracking Preset Adjustment

REMOTE BUTTONS	CONTROL PULSE REMOVE
PUSH	
▲ FINE ▼	
▲ FINE ▼ PUSH	

Fig. 4-5-5 Control Pulse Adjustment

4-5-1(e) A/C HEAD POSITION (X-POINT). ADJUSTMENT (PAL SYSTEM ONLY)

1. Play back the mono scope alignment tape.
2. Connect Ch1 scope probe to "CTRL" and Ch-2 scope probe to "H'D SW".  
Trigger on the head-switching pulse.
3. Set the tracking preset to 7 msec using the "Fine" tracking buttons ▲ / ▼ on the remote control.
4. Connect Ch1 scope probe to "ENV"; connect Ch-2 to "H'D SW" and trigger on Ch-1.
5. Insert the adjusting driver (+) into the X-position adjusting gear. Adjust the driver in either direction for maximum envelope waveform.
6. Note: Since the adjusting gear unit may be damaged, do not adjust the X-point by using force. After turning the X-point adjusting screw (D) slightly counter-clockwise, perform the adjustment and then tighten the screw.

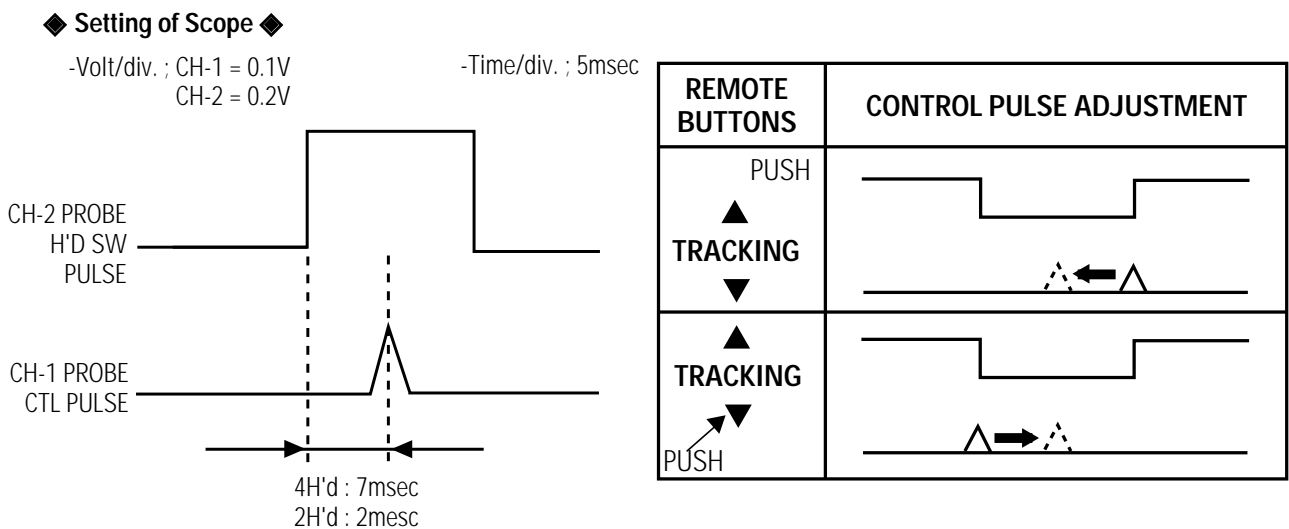

Fig. 4-5-5 Tracking Preset and Control Adjustment  
Only for Models. SV-20U/30U/40U/60U/100U  
VR3705/VR3805/5705/5805/8705

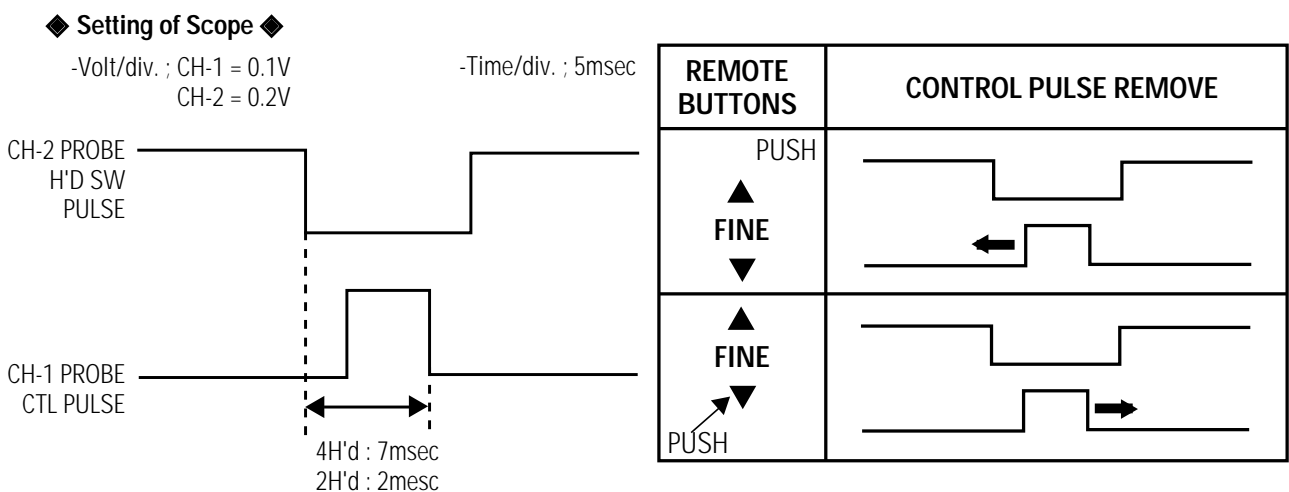

Fig. 4-5-6 Tracking Preset and Control Adjustment  
Only for Models. sv-70U/90U/120U/140U/160U  
VR5805/VR5855/5905/8905

### 4-5-2 Linearity adjustment (Guide roller S, T adjustment)

1. Playback the Mono Scope alignment tape (SP mode).
2. Observe the video envelope signal on an oscilloscope (triggered by the video switching pulse).
3. Make sure the video envelope waveform (at its minimum) meets the specification shown in Fig. 4-5-7.

If it does not, adjust as follows :

Note :

- a=Maximum output of the video RF envelope.
- b=Minimum output of the video RF envelope at the entrance side.
- c=Minimum output of the video RF envelope at the center point.
- d=Maximum output of the video RF envelope at the exit side.

4. If the section A in Fig. 4-5-8 does not meet the specification, adjust the guide roller S up or down.
5. If the section B in Fig. 4-5-8 does not meet the specification, adjust the guide roller T up or down.
6. Play back the Mono Scope alignment tape (SP mode).
7. Connect an oscilloscope CH-1 to the Envelope and CH-2 to the H'D SW Pulse for triggering.
8. Turn the guide roller heads with a flat head (  ) driver to obtain a flat video RF envelope as shown in Fig. 4-5-9.

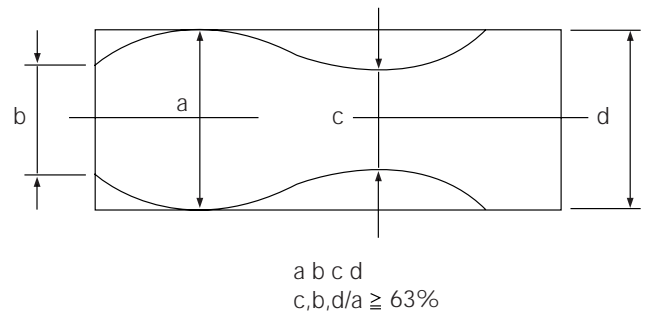

Fig. 4-5-7 Envelope Waveform Adjustment

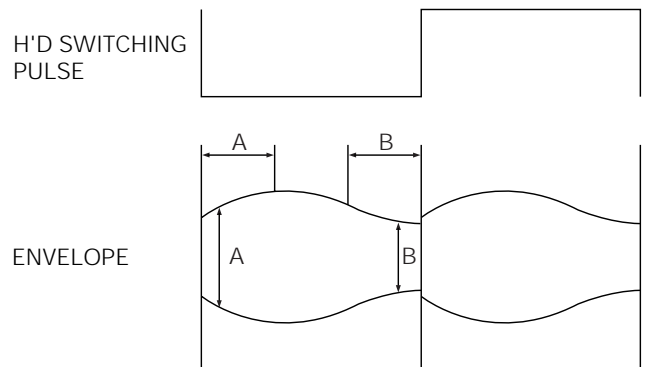

Fig. 4-5-8 Adjustment Points

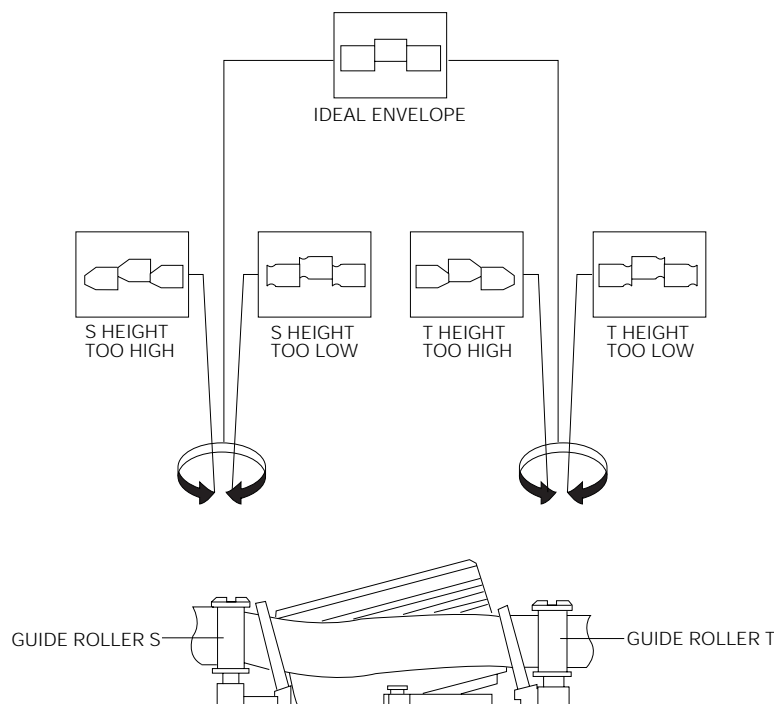

Fig. 4-5-9 Guide Roller S, T Height Adjustment

### 4-5-3 Check Transition from RPS to Play

Check transition from RPS mode to play mode :  
 Using a pre-recorded SP tape, make sure the entry side of envelope comes to an appropriate steady state within 3 seconds (as shown in Fig. 4-5-10).  
 If the envelope waveform does not reach specified peak to peak amplitude within 3 seconds, adjust as follows :

1. Make sure there is no gap between the supply roller lower flange and the tape.  
 If there is a gap, adjust the supply guide roller again.
2. Change operation mode from the RPS to the play mode (again) and make sure the entry side of envelope rises within 3 second.

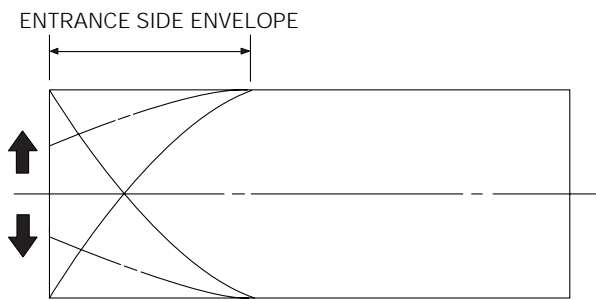

Fig. 4-5-10 Video Envelope Rising when Operation mode Changes from RPS to Play Mode

### 4-5-4 Envelope Check

1. Make recordings on T-120 (E-120) and T-160 (E-180) tape.  
 Make sure the playback output envelope meets the specification as shown in Fig. 2-10.
2. Play back a self recorded tape (recording made on the unit using with T-120 (E-120)).  
 The video envelope should meet the specification as shown in Fig. 4-5-11. In SP mode, (A) should equal (B).  
 If the head gap is wide, upper cylinder should be checked.

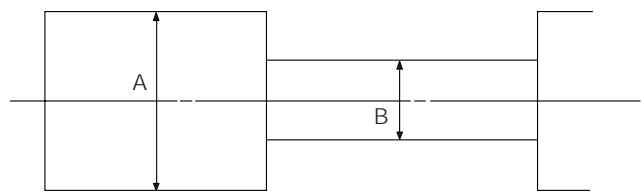

Fig. 4-5-11 Envelope Output and Output Level

### 2-2-5 Tape Wrinkle Check

1. Run the T-160 (E-180) tape in the playback, FPS, RPS and Pause modes and observe tape wrinkle at each guide.
2. If excessive tape wrinkle is observed, perform the following adjustments in Playback mode :
  - ◆ Tape wrinkle at the guide roller S, T section :  
 Linearity adjustment.
  - ◆ Tape wrinkle at tape guide flange :  
 ACE head assembly coarse adjustment.

## 4-6 Reel Torque

1. The rotation of the capstan motor causes the Holder Clutch Ass'y to rotate through the Belt Pulley.
2. The spring wrap PLAY/REV of holder clutch ass'y drives the disk reel S, T through gear idle by rotation of gear center ass'y.
3. Brake is operated by slider cam at FF/REW mode.
4. Transportation of accurate driving force is done by gears. (Gear Center Ass'y)

Note : If the specifications are not met, replace the holder clutch ass'y and then recheck.

<Table 4-6>

MODE	TORQUE g/cm		GAUGE
PB	NTSC	82.5 ± 27.5	Cassette Torquemeter
	PAL	79 ± 27	
RPS	145 ± 30		Cassette Torquemeter

## 4-7 Location Adjustment and Confirmation of Tension Post

1. Remove the holder cassette ass'y and then push the lever FL Arm-R to the direction of loading.
2. Push the lever tension drive ❶ in the direction of arrow. (See Fig. 4-5-12)
3. Turn the gear worm wheel ❷ clockwise so that "Timing Point" of the slider FL drive ❸ and gear FL cam ❹ can be aligned (See Fig. 4-5-13)

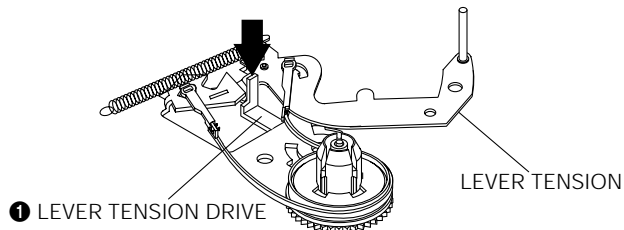

Fig.4-5-12

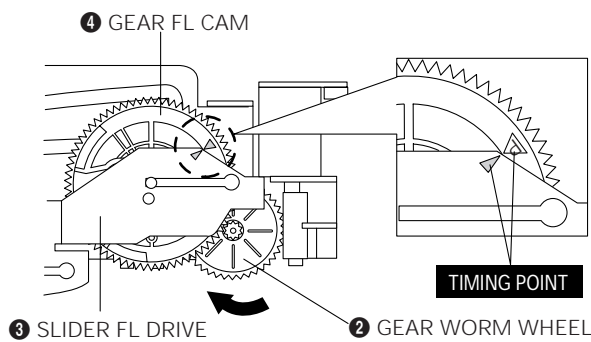

Fig. 4-5-13

4. Rotate Disk S Reel ❶ clockwise and do the adjustment in the region around the Main Base (in shape of slit). Clockwise or counterclockwise after inserting it turn the screw driver in the slit on the Main Base. Adjust the left end edge of Lever Tension Ass'y ❸ to  $1.3 +1.5/-0.5$ mm (from the location of mark in the Main Base).
5. Rotate Disk S Reel ❶, and double-check the location of the left end edge of Lever Tension Ass'y, and the amount of crossing from the mark on Main Base. ( $+1.0/-0.5$ mm)

Counterclockwise : Torque UP  
Clockwise : Torque DOWN

Back Tension should be  $56 \pm 15$ g.cm (use a Back Tension Meter).

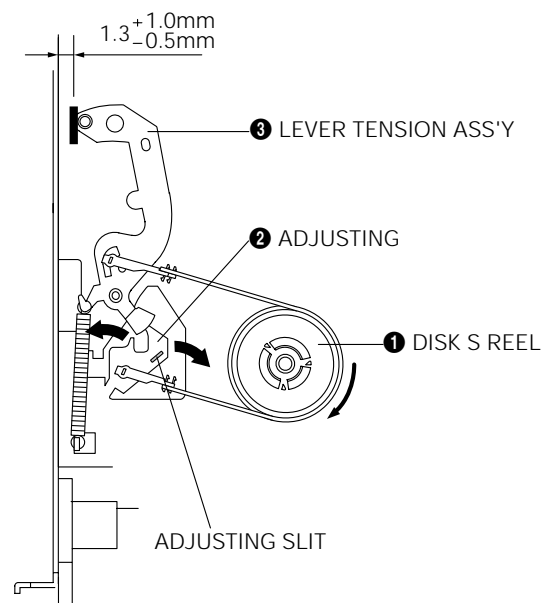

Fig. 4-5-14 Tension Pole and Back Tension Adjustment

Note :

- 1 Mark on Main Base is located about 1.3mm from inside of curved line.
- 2 Be careful not to deform the region of adjustment around the Main Base (up or down).

---

## 5. Alignment and Adjustments (Electrical)

---

### 5-1 Preadjustment

---

#### 5-1-1 Factory Mode

1. Do not attempt these adjustments in the Video Mode.
2. The Factory Mode adjustments are necessary when either the EEPROM (IC902) or the CRT is replaced.
3. Do not tamper with the "Adjustment" screen of the Factory Mode menu. This screen is intended only for factory use.

#### 5-1-3 When CRT Is Replaced

Make the following adjustments after setting up purity and convergence:

White Balance  
Sub-Brightness  
Vertical Center  
Vertical Size  
Horizontal Size

#### 5-1-2 When EEPROM (IC902) Is Replaced

1. When IC902 is replaced all adjustment data revert to initial values. It is necessary to re-program this data.
2. After IC902 is replaced, warm up the TV for 10 seconds.

---

## 5-2 Factory ("Service") Mode

---

### 5-2-1 Procedure for the "Adjustment" Mode

1. This mode uses the standard remote control. The Service Mode is activated by: (1) pressing the "FACTORY" service key on the local-keyboard, or (2) by entering the following remote-control sequence (within 2 seconds):  
  
STAND-BY → DISPLAY → MENU → MUTE → POWER ON
2. The "SERVICE (FACTORY)" message will be displayed. The Service Mode has three components: Adjustment, Option Bytes and Reset.
3. Access the Adjustment Mode by pressing the "VOLUME" keys ( Up or Down). The adjustment parameters are listed in the accompanying table, and selected by pressing the CHANNEL keys (▲, ▼).
4. Selection sequences for the PAL/SECAM B/G, L systems:  
  
down or up key:  
AGC>VCO>AFW>SBT>SCT>SCR>RG>GG>BG>TCT>SC>SL>VA>PVS>PHS>CDL>BKS
5. The VOLUME keys increase or decrease the adjustment values, (stored in the non-volatile memory) when Adjustment Mode is cancelled.

### 5-2-2 Main Adjustment Parameters

FUNCTION	OSD ABBREVIATION	RANGE	INITIAL DATA
AUTO GAIN CONTROL	AGC	0 ~ 63 STEP	12
SUB BRIGHT	SBT	0 ~ 13 STEP	6
SUB CONTRAST	SCT	0 ~ 13 STEP	14" : 06
			20/21" : 10
SUB COLOR	SCR	0 ~ 13 STEP	14" : 06
			20/21" : 04
SUB TINT	STT	0 ~ 13 STEP	9
RED GAIN	RG	0 ~ 63 STEP	38
GREEN GAIN	GG	0 ~ 63 STEP	32
BLUE GAIN	BG	0 ~ 63 STEP	33
TELETEXT CONTRAST	TCT	0 ~ 38 STEP	04
VERTICAL SLOPE	SL	0 ~ 63 STEP	28
PAL VERTICAL SHIFT	PVS	0 ~ 63 STEP	30
VERTICAL AMPLITUDE	VA	0 ~ 63 STEP	43
PAL HORIZONTAL SHIFT	PHS	0 ~ 63 STEP	33
CATHOD DRIVE LEVEL	CDL	0 ~ 07 STEP	14" : 03
			20/21" : 04
NTSC VERTICAL AMPLITUDE	NVS	0 ~ 63 STEP	30
BLACK STRETCHER	BKS	0 ~ 01 STEP	01
NTSC HORIZONTAL SHIFT	NHS	0 ~ 63 STEP	46
AUTO FREQUENCY WINDOW	AFW	0 ~ 01 STEP	00
S-CORRECTION	SC	0 ~ 63 STEP	14/20" : 00
			21" : 11

NOTE : PVS, PVA, PHS, NVS, NVA, NHS parameters must be aligned using both the 50 Hz and 60 Hz vertical-field rates.

### 5-2-3 AGING Mode (Reference Only)

This pattern is used for pre-heating the CRT during manufacturing--it is accessed in the factory by twice pressing the "FACTORY" key .

Even if the TV power is cut off, the Aging Mode is not cancelled.

The "AGING" marking is displayed on the screen.

The AGING mode is cancelled by repressing the "FACTORY" key.

### 5-2-4 Option

BIT	ITEM	0	1	REMARK
7	TTX	NO TTX	TTX	
6	TTX SYSTEM	LIST FIRST	FLOF FIRST	
5	CONTRAST	70	90	
4	TUNER QUANTITY	1	2	
3	–	–	–	
2	SYSTEM (L)			
1	SYSTEM (D/K)			
0	SYSTEM (I)			

1. After an option is modified, the system must be reset in order for the change to take effect.
2. Bit 6 : TTX System. This bit reverts to its initial value during Power ON.
3. Bit 5 : After a "Factory Reset", the Contrast Option determines the contrast level during Memory Mode.
4. Bit 3 : Not used.
5. Bits 2,1,0 :

#2 (L)	#1 (D/K)	#0 (I)	AREA	COLOR SYSTEM	SOUND SYSTEM
0	0	0	WEST, SCAN	AUTO, PAL, SECAM	X
0	0	1	UNITED KINGDOM ®	AUTO, PAL	X
0	1	0	EAST,CIS	AUTO, PAL, SECAM	AUTO, B/G, D/K
0	1	1	CHINA, HONG KONG	AUTO, PAL, SECAM	AUTO, B/G, D/K, I
1	0	0	FRANCE	PAL/SECAM, FRANCE ®É	X
1	0	1	ITALY	AUTO, PAL	X
1	1	0	OCEANIA	AUTO PAL	X
1	1	1	NOT USED (DEFAULT OPERATION = WEST, SCAN)		

Note1: United Kingdom: 468 - 900MHz (UHF only)

Others: 40 - 900 MHz

Note2: Color decoder mode is always "auto"

SYSTEM	MODULATION STANDARD	COLOUR DECODER MODE
PAL/SECAM	NEGATIVE	AUTO
FRANCE	POSITIVE	AUTO

**5-2-5 Option 2**

BIT	ITEM	0	1	REMARK
7	NOT USED			
6	NOT USED			
5	SHARPNESS	OFF	ON	
4	PDC	NO	YES	
3	VPS	NO	YES	
2	3.58 X-TAL	NO	YES	
1	VIDEO PLUS	NO	YES	
0	SHOWVIEW	NO	YES	

Notes:

Bit 5 : Sharpness ON : When this bit=1, the peaking will be activated.

Bits 4, 3 : VPS and VDC cannot exist simultaneously. (The same applies for VIDEO PLUS and SHOWVIEW)

**5-2-6 VCR Option**

BIT	ITEM	0	1	REMARK
7	NOT USED			
6	NOT USED			
5	NOT USED			
4	HEAD	2-HEAD	4-HEAD	
3	SP/LP	SP ONLY	SP/LP	
2	SECAM	N/A	POSSIBLE	
1	MESECAM	N/A	POSSIBLE	
0	NTSC3.58	N/A	POSSIBLE	

**5-3 Reset**

The Reset Mode is used during factory inspection.

Function Reset : After Factory Reset, the following items revert to their initial values.

- |    |                          |           |
|----|--------------------------|-----------|
| 1. | Volume                   | 10        |
| 2. | Program Channel          | 0         |
| 3. | P-STD                    | MEMORY    |
| 4. | Auto Power               | OFF       |
| 5. | NR                       | OFF       |
| 6. | Reserved Timer Recording | ALL CLEAR |
| 7. | Skip (Store/Clear)       | ALL CLEAR |

Caution : When the EEPROM is replaced, all items revert to their initial values.

## 5-4 Other Adjustments

---

### 5-4-1 General

1. Usually, a color TV needs only slight touch-up adjustment upon installation. Check the basic characteristics such as height, horizontal and vertical sync and focus.
2. The picture should have good black and white details. There should be no objectionable color shading; if color shading is present, perform the purity and convergence adjustments described below.
3. Use the specified test equipment or its equivalent.
4. Correct impedance matching is essential.
5. Avoid overload. Excessive signal from a sweep generator might overload the front-end of the TV. When inserting signal markers, do not allow the marker generator to distort test results.
6. Connect the TV only to an AC power source with voltage and frequency as specified on the backcover nameplate.
7. Do not attempt to connect or disconnect any wires while the TV is turned on. Make sure that the power cord is disconnected before replacing any parts.
8. To protect against shock hazard, use an isolation transformer.

### 5-4-2 Automatic Degaussing

A degaussing coil is mounted around the picture tube, so that external degaussing after moving the TV should be unnecessary. But the receiver must be properly degaussed upon installation.

The degaussing coil operates for about 1 second after the power is switched ON. If the set has been moved or turned in a different direction, disconnect its AC power for at least 10 minutes.

If the chassis or parts of the cabinet become magnetized, poor color purity will result. If this happens, use an external degaussing coil. Slowly move the degaussing coil around the faceplate of the picture tube and the sides and front of the receiver. Slowly withdraw the coil to a distance of about 6 feet before removing power.

### 5-4-3 High Voltage Check

**CAUTION:** There is no high voltage adjustment on this chassis. The B+ power supply must be set to +125 volts (Full color bar input and normal picture level).

1. Connect a digital voltmeter to the second anode of the picture tube.
2. Turn on the TV. Set the Brightness and Contrast controls to minimum (zero beam current).
3. The high voltage should not exceed 27.5KV.
4. Adjust the Brightness and contrast controls to both extremes. Ensure that the high voltage does not exceed 27.5KV under any conditions.

#### **5-4-4 FOCUS Adjustment**

1. Input a black and white signal.
2. Adjust the tuning control for the clearest picture.
3. Adjust the FOCUS control for well defined scanning lines in the center area of the screen.

#### **5-4-5 Screen Adjustment**

1. Turn to the ACTIVE channel.
2. Adjust the VR screen for a normal picture is (no blooming or flyback line).
3. Adjust the FOCUS control for well defined scanning lines in the center area of the screen.

#### **5-4-6 Purity Adjustment**

1. Warm up the receiver for at least 20 minutes.
2. Plug in the CRT deflection yoke and tighten the clamp screw.
3. Plug the convergence yoke into the CRT and set in as shown in Fig. 5-1.
4. Input a black and white signal.
5. Fully demagnetize the receive by applying an external degaussing coil.
6. Turn the CONTRAST and BRIGHTNESS controls to maximum.
7. Loosen the clamp screw holding the yoke. Slide the yoke backward or forward to provide vertical green belt. (Fig. 5-2).
8. Tighten the convergence yoke.
9. Slowly move the deflection yoke forward, and adjust for the best overall green screen.
10. Temporarily tighten the deflection yoke.
11. Produce blue and red rasters by adjusting the low-light controls. Check for good purity in each field.
12. Tighten the deflection yoke.

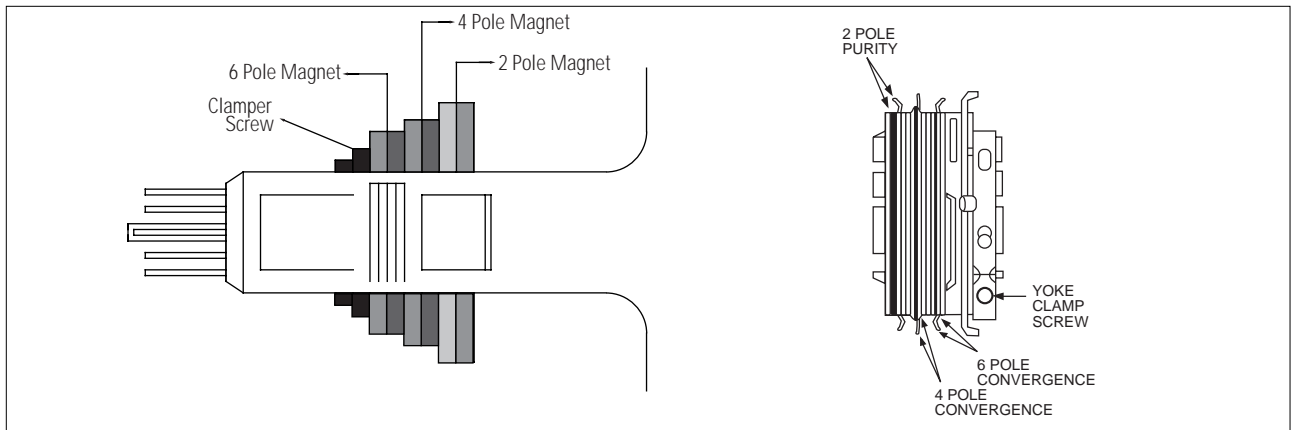

Fig. 5 -1 Convergence Magnet Assembly

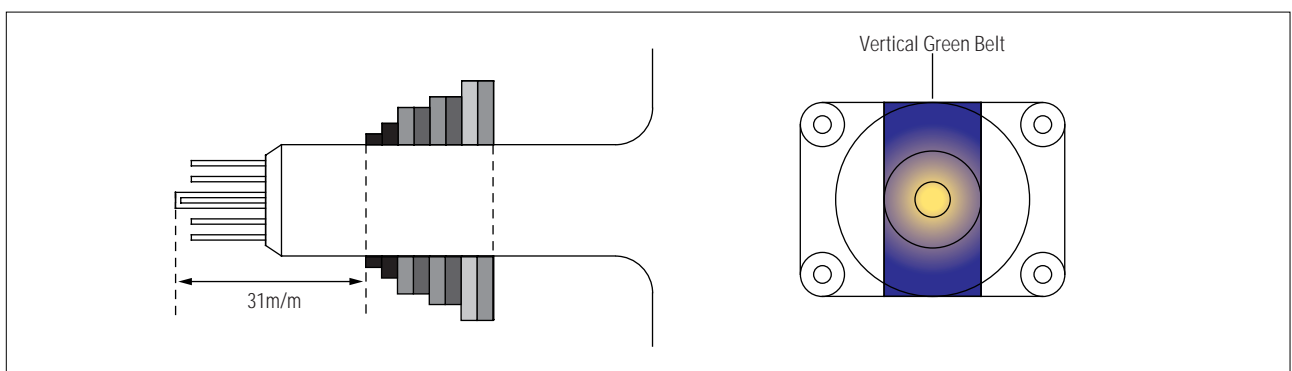

Fig. 5-2 Center Convergence Adjustment

### 5-4-7 White Balance Adjustment

#### 5-4-7 (A) HIGH-LIGHT ADJUSTMENT

1. Input either a Lion Head or a "pure white" pattern.
2. Warm up the TV for 30 minutes.
3. Check the data in the Service Mode
4. Adjust RG, BG in the Factory Mode.

#### 5-4-7 (B) LOW-LIGHT ADJUSTMENT

1. Automatically accomplished during the high-light adjustment.

### 5-4-8 Center Convergence Adjustment

1. Warm up the receiver for at least 20 minutes.
2. Adjust the two tabs of the 4 pole magnets to change the angle between them. Superimpose the red and blue vertical lines in the center area of the screen.
3. Adjust the Brightness and Contrast controls for a well defined picture.
4. Adjust the two-tab pairs of the 4 pole magnets, and change the angle between them. Superimpose the red and the blue vertical lines in the center area of the screen.
5. Turn the both tabs at the same time, keeping the angle constant, and superimpose the red and blue horizontal line in the center of the screen.
6. Adjust the two-tab pairs of the 6-pole magnets to superimpose the red and blue line onto the green. (Changing the angle affects the vertical lines, and rotating both magnets affects the horizontal lines.)
7. Repeat adjustments 2~6, if necessary.
8. Since the 4-pole magnets and 6-pole magnets interact, the dot movement is complex (Fig. 5-3).

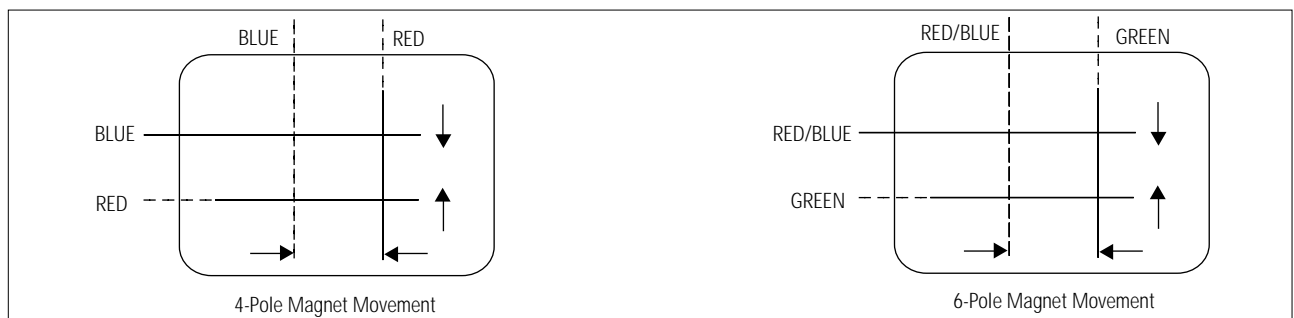

Fig 5-3 Center Convergence Adjustment

### 5-4-9 Dual Tuner AFT Adjustment

#### Test Equipment

1. TV Generator (PM5518,PM5418,ETC.)
2. DC VOLTMETER

1. Connect DC Voltmeter to AFT terminal of TUNER IF-MODULE.
2. After selecting P00, input to IF1 terminal of TU002 (38.9 MHz Using PM5518)
3. After selecting P00, set to 2.5V  $\pm$  0.2V (Using FRANCE : T101, PAL/SCAM B/G,I,D/K : L102)

## 5-5 Electrical Adjustment (VCR Section)

### 5-5-1 Preparation

Electrical adjustments are required after replacing circuit components and certain mechanical parts. It is important to perform these adjustment only after all repairs and replacements have been completed. Also, do not attempt these adjustments unless the proper equipment is available.

### 5-5-2 Required Test Equipment

1. Color Television or Monitor
2. Oscilloscope : Wide-band, dual-trace, triggered delayed sweep.
3. DC Voltmeter
4. TV CH Generator
5. Attenuator
6. Recording tape. (Blank tape)
7. Pattern Generator : PAL color bar. 100% White.

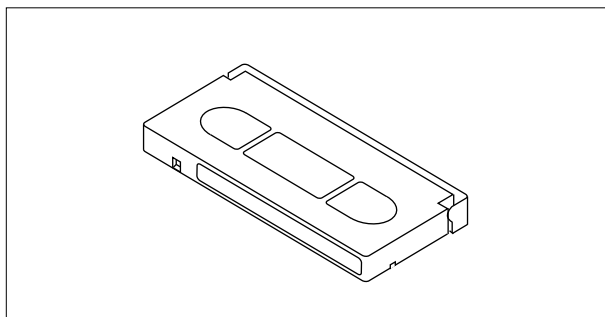

Fig. 5-4 Alignment Tape

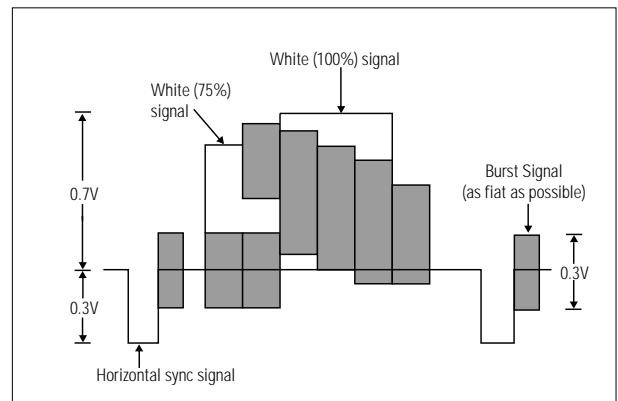

Fig. 5-5 Color bar signal of pattern generator

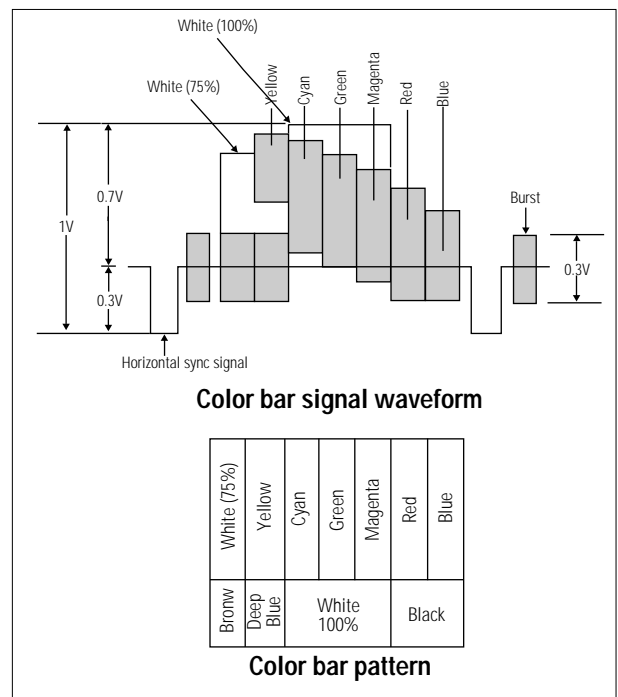
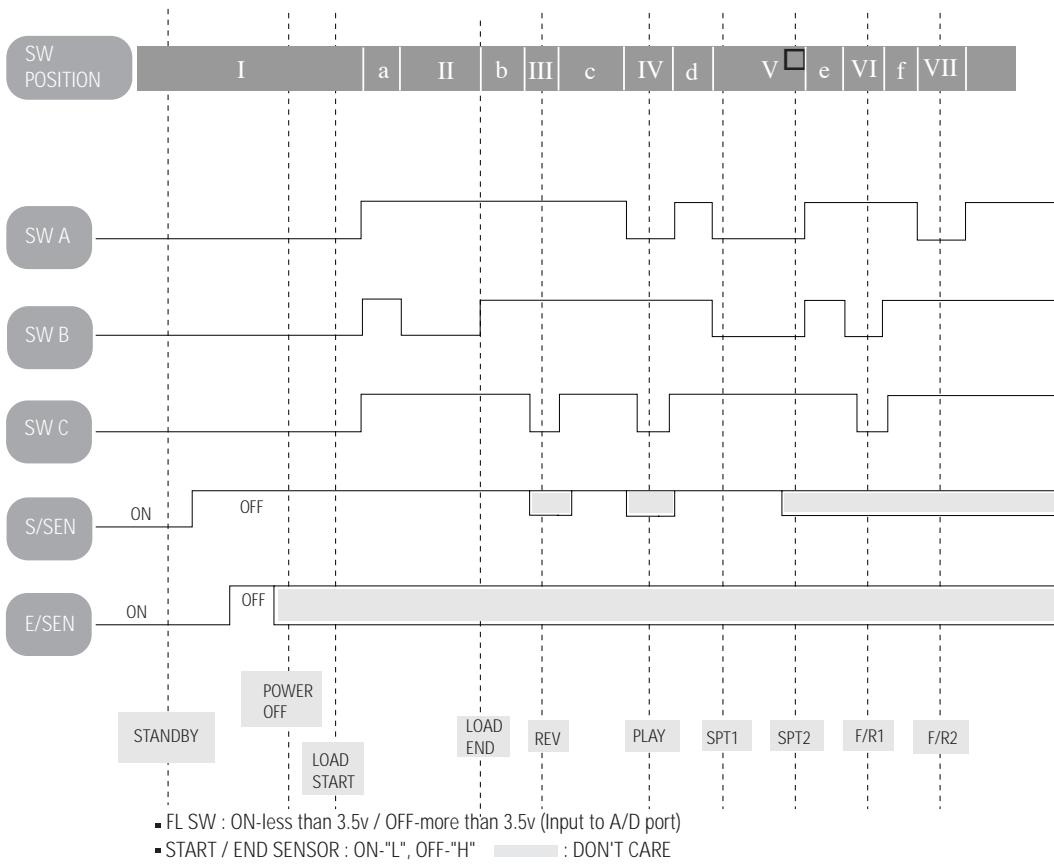

Fig. 5-6 Color bar signal of alignment tape (75% Color Bars)

### 5-5-3 PROGRAM SW



POSITION	PROGRAM S/W			TAPE SEN		OPERATION MODE
	A	B	C	S	F	
STANBY	0	0	0	0	0	Eject
POWER OFF	0	0	0	1	X	Unload POWER OFF
LOADING START	0	0	0	1	X	(Tape loading start point)
LOADING END	1	0 -> 1	1	1	X	(Tape loading end point)
REV	1	1	0	X	X	Reverse Picture Search, Reverse SLOW
PLAY	0	1	0	X	X	Play, Rec,F-PS,Still,SLOW,F-ADV
STOP1	0	0	1	1	X	Stop (Play position 5 Min. over)
STOP 2	0	0	1	X	X	(MAIN Break ON MODE)
FF / REW 1	1	0	0	X	X	High speed Rew, Low speed FF
FF / REW 2	0	1	1	X	X	High speed FF, Low speed Rew

X : DON'T CARE

5-6-1 TS M/DECK OPTION TABLE (PAL)

NO	LOCA-NO	CODE-NO	SPECIFICATION	DESCRIPTION	M-440	M-441	M-420	M-421	M-422	M-420	M-421	M-422	M-420	M-421	M-422	M-420	M-421	M-422	REMARK		
					WKD/ BWT-S	WKD/ BWT-S	FK/ SEF-S	FK/ SEF-S	FK/ SEF-S	XK/ SEG-S	XK/ SEG-S	XK/ SEG-S	IK/ UK-S	IK/ UK-S	IK/ UK-S	YK/ SIEL-S	YK/ SIEL-S	YK/ XEG-S		YK/ XEG-S	YK/ XEG-S
1		M/DECK ASSY			AA94-80004R	AA94-00193C	AA94-80004T	AA94-00193E	AA94-00193S	AA94-80004U	AA94-00193F	AA94-00193T	AA94-80004V	AA94-00193H	AA94-00193P	AA94-80004Z	AA94-00193M	AA94-80005L	AA94-00193N	AA94-00193Q	
2		DECK ASSY			AA91-40108A	AA91-40108A	AA91-40112A	AA91-40112A	AA91-40112A	AA91-40112A	AA91-40112A	AA91-40112A	AA91-40113A	AA91-40113A	AA91-40113A	AA91-40114A	AA91-40114A	AA91-40112A	AA91-40112A	AA91-40112A	
3		DURM ASSY																			
4		PCB ASSY			AA95-00091B	AA95-00091M	AA95-00091E	AA95-00091Q	AA95-00091Q	AA95-00091F	AA95-00091R	AA95-00091R	AA95-00091G	AA95-00091S	AA95-00091S	AA95-00091K	AA95-00091V	AA95-00091K	AA95-00091V	AA95-00091V	
5		AA41-10983B	300X245	PCB	0	0	0	0	0	0	0	0	0	0	0	0	0	0	0	0	STANDARD
6	CM330	2401-001513	47/16V	C-AL	X	X	X	X	X	X	X	X	X	X	X	X	X	X	X	X	
7	CM336	2202-000127	103P	C	0	0	0	0	0	0	0	0	0	0	0	0	0	0	0	0	PAL
8	CM388	2202-000127	103P	C	X	X	X	X	X	X	X	X	X	X	X	X	X	X	X	X	MULTI
9	DM712	0401-000005	1N4148	D	0	0	X	X	X	X	X	X	X	X	X	X	X	X	X	X	4HD
10	DM713	0401-000005	1N4148	D	X	X	0	0	0	X	X	X	X	X	X	X	X	X	X	X	SECAM
11	DM714	0401-000005	1N4148	D	0	0	0	0	0	0	0	0	X	X	X	X	X	X	X	X	MESECAM
12	DM715	0401-000005	1N4148	D	X	X	X	X	X	X	X	0	0	0	X	X	X	X	X	X	2HD LP
13	DM716	0401-000005	1N4148	D	X	X	X	X	X	X	X	X	X	X	X	X	X	X	X	X	MULTI
14	DM717	0401-000005	1N4148	D	X	X	X	X	X	X	X	X	X	X	X	X	X	X	X	X	NT3.58
15	ICM301	1204-001410	LA71590M	IC	0	0	0	0	0	0	0	0	0	0	0	0	0	0	0	0	PAL
		1204-001403	LA71570M		X	X	X	X	X	X	X	X	X	X	X	X	X	X	X	X	X
16	QM303	0504-000119	R1004	TR	X	X	X	X	X	X	X	0	0	0	X	X	X	X	X	X	2HD LP
17	QM316	0501-000398	C945	TR	X	X	X	X	X	X	X	X	X	X	X	X	X	X	X	X	D.REC
18	RM320	2001-000554	270	R	X	X	X	X	X	X	X	0	0	0	X	X	X	X	X	X	2HD LP
19	RM326	2001-000837	51K	R	X	X	X	X	X	X	X	X	X	X	X	X	X	X	X	X	D.REC
20	RM337	2001-000268	1.8K	R	X	X	X	X	X	X	X	X	X	X	X	X	X	X	X	X	MULTI
21	RM375	2001-000268	1.8K	R	X	X	X	X	X	X	X	X	X	X	X	X	X	X	X	X	PB FM
22	RM376	2001-000268	1.8K	R	X	X	0	0	0	X	X	X	X	X	X	X	X	X	X	X	SECAM
23	RM374	2001-000244	1.5M	R	X	X	X	X	X	X	X	X	X	X	X	X	X	X	X	X	
24	RM656	2001-000290	10K	R	X	X	X	X	X	X	X	X	X	X	X	X	X	X	X	X	CTL
25	XTM302	2801-003610	3.579545M	X-TAL	X	X	X	X	X	X	X	X	X	X	X	X	X	X	X	X	MULTI
26	ICM604	1203-000515	7042	IC-VOL	X	X	X	X	X	X	X	X	X	X	X	X	X	X	X	X	BACK-UP
27	CM646	2401-002259	0.1F,5.5V	C-AL	X	X	X	X	X	X	X	X	X	X	X	X	X	X	X	X	BACK-UP
28	RM695	2001-000568	27	R	X	X	X	X	X	X	X	X	X	X	X	X	X	X	X	X	BACK-UP
29	SECAM BLOCK	-	-	-	X	X	0	0	0	X	X	X	X	X	X	X	X	X	X	X	SECAM ONLY
30	CM384	2202-000830	82P	C	X	X	X	X	X	X	X	X	X	X	X	X	X	X	X	X	TV-V-IN
31	CM394	2202-000806	221P	C	X	X	X	X	X	X	X	X	X	X	X	X	X	X	X	X	A.OUT
32	CM386	2202-000127	103P	C	X	X	X	X	X	X	X	X	X	X	X	X	X	X	X	X	GND
33	JM225	3812-000219	JUMPER	JM	0	0	X	X	X	0	0	0	0	0	0	0	0	0	0	0	WITHOUT SECAM
34	RM379	2001-000290	10K	R	X	X	X	X	X	X	X	X	X	X	X	X	X	X	X	X	
35	JM177	3812-000219	JUMPER	JM	X	X	X	X	X	X	X	X	X	X	X	X	X	X	X	X	AU-HUM
36	CNM611	3711-000682	CONN,13P	WAFER	X	X	X	X	X	X	X	X	X	X	X	X	X	X	X	X	
37	CM396	2202-000127	103P	C	X	X	X	X	X	X	X	X	X	X	X	X	X	X	X	X	MULTI
38	ICM103	1203-000190	78L05	IC-TR	X	X	X	X	X	X	X	X	X	X	X	X	X	X	X	X	POWER SUPPLY

**5-6-1 OPTION TABLE (Continued)**

39	JM112	3812-000219	JUMPER	JM	X	X	X	X	X	X	X	X	X	X	X	X	X	X	X	POWER SUPPLY
40	JM165	3812-000219	JUMPER	JM	X	X	X	X	X	X	X	X	X	X	X	X	X	X	X	POWER SUPPLY
41	RM380	2001-001031	91K	R	0	0	X	X	X	X	X	X	X	X	X	X	X	X	X	4HD
42	QM318	0504-000119	R1004	TR	0	0	X	X	X	X	X	X	X	X	X	X	X	X	X	4HD
43	JM227	3812-000219	JUMPER	JM	0	0	X	X	X	X	X	X	X	X	X	X	X	X	X	4HD
KEY OPTION (DELETED WHEN A CONTROL ASSY IS ADDED)																				
44	SWM601	3404-000244	SW-TACT	SW	0	X	0	X	X	0	X	X	0	X	X	0	X	0	X	KEY
45	SWM602	3404-000244	SW-TACT	SW	0	X	0	X	X	0	X	X	0	X	X	0	X	0	X	KEY
46	SWM603	3404-000244	SW-TACT	SW	0	X	0	X	X	0	X	X	0	X	X	0	X	0	X	KEY
47	SWM604	3404-000244	SW-TACT	SW	0	X	0	X	X	0	X	X	0	X	X	0	X	0	X	KEY
48	SWM605	3404-000244	SW-TACT	SW	0	X	0	X	X	0	X	X	0	X	X	0	X	0	X	KEY
49	SWM606	3404-000244	SW-TACT	SW	0	X	0	X	X	0	X	X	0	X	X	0	X	0	X	KEY
50	SWM607	3404-000244	SW-TACT	SW	0	X	0	X	X	0	X	X	0	X	X	0	X	0	X	KEY
51	SWM608	3404-000244	SW-TACT	SW	0	X	0	X	X	0	X	X	0	X	X	0	X	0	X	KEY
52	SWM609	3404-000244	SW-TACT	SW	0	X	0	X	X	0	X	X	0	X	X	0	X	0	X	KEY
53	CM631	2202-002037	104P	C	0	X	0	X	X	0	X	X	0	X	X	0	X	0	X	KEY
54	CM632	2401-002009	100/16V	C-AL	0	X	0	X	X	0	X	X	0	X	X	0	X	0	X	KEY
55	DM607	0401-000005	1N4148	D	0	X	0	X	X	0	X	X	0	X	X	0	X	0	X	KEY
56	DM608	0401-000005	1N4148	D	0	X	0	X	X	0	X	X	0	X	X	0	X	0	X	KEY
57	DM609	0401-000005	1N4148	D	0	X	0	X	X	0	X	X	0	X	X	0	X	0	X	KEY
58	ZDM601	0403-000654	MTZ12B	ZENER	0	X	0	X	X	0	X	X	0	X	X	0	X	0	X	KEY
59	LM602	AA91-60317A	G-LED.03	ASSY	0	X	0	X	X	0	X	X	0	X	X	0	X	0	X	KEY
60	CNM611	3711-000683	13P	CON	X	0	X	0	0	X	0	0	X	0	0	X	0	X	0	KEY ADD
61	QM603	0504-000118	R1003	TR	0	X	0	X	X	0	X	X	0	X	X	0	X	0	X	KEY
62	QM604	0504-000118	R1003	TR	0	X	0	X	X	0	X	X	0	X	X	0	X	0	X	KEY
63	QM605	0504-000118	R1003	TR	0	X	0	X	X	0	X	X	0	X	X	0	X	0	X	KEY
64	RM631	2001-001077	150,1/2W	R	0	X	0	X	X	0	X	X	0	X	X	0	X	0	X	KEY
65	RM632	2001-001077	150,1/2W	R	0	X	0	X	X	0	X	X	0	X	X	0	X	0	X	KEY
66	RM633	2001-001077	150,1/2W	R	0	X	0	X	X	0	X	X	0	X	X	0	X	0	X	KEY
67	RM637	2001-000290	10K	R	0	X	0	X	X	0	X	X	0	X	X	0	X	0	X	KEY
68	JM114	3812-000219	JUMPER	JM	0	X	0	X	X	0	X	X	0	X	X	0	X	0	X	KEY
69	JM127	3812-000219	JUMPER	JM	0	X	0	X	X	0	X	X	0	X	X	0	X	0	X	KEY
70	JM136	3812-000219	JUMPER	JM	0	X	0	X	X	0	X	X	0	X	X	0	X	0	X	KEY
71	JM138	3812-000219	JUMPER	JM	0	X	0	X	X	0	X	X	0	X	X	0	X	0	X	KEY
72	JM147	3812-000219	JUMPER	JM	0	X	0	X	X	0	X	X	0	X	X	0	X	0	X	KEY
73	JM212	3812-000219	JUMPER	JM	0	X	0	X	X	0	X	X	0	X	X	0	X	0	X	KEY
74	JM213	3812-000219	JUMPER	JM	0	X	0	X	X	0	X	X	0	X	X	0	X	0	X	KEY
75	JM214	3812-000219	JUMPER	JM	0	X	0	X	X	0	X	X	0	X	X	0	X	0	X	KEY
76	JM215	3812-000219	JUMPER	JM	0	X	0	X	X	0	X	X	0	X	X	0	X	0	X	KEY
77	REM601	AA59-60003V	REMO-MOD		0	X	0	X	X	0	X	X	0	X	X	0	X	0	X	KEY

## 5-6-2 SECAM BLOCK LIST OPTION TABLE

N O	LOCA - NO	CODE - NO	DESCRIPTION	SPECIFICATION	REMARK
1	CM901	2202-000127	C-CERA	103P	
2	CM902	2301-000224	C-FILM	223P	
3	CM903	2201-000376	C-CERA	220P	RADIAL
4	CM904	2201-000193	C-CERA	10P	RADIAL
5	CM905	2201-000863	C-CERA	680P	RADIAL
6	CM906	2202-000127	C-CERA	103P	
7	CM907	2201-000681	C-CERA	82P	RADIAL
8	CM908	2401-000426	C-AL	10uF/16V	
9	CM909	2202-000796	C-CERA	102P	
10	CN910	2401-001333	C-AL	0.47uF/50V	
11	CM911	2202-002036	C-CERA	51P	
12	CM912	2202-000127	C-CERA	103P	
13	CM913	2202-002037	C-CERA	104P	
14	CM914	2201-000234	C-CERA	150P	RADIAL
15	CM915	2301-000383	C-FILM	103P	
16	CM916	2401-002291	C-AL	47uF/16V	
17	CM917	2202-002037	C-CERA	104P	
18	CM918	2301-000383	C-FILM	103P	
19	CM919	2301-000383	C-FILM	103P	
20	CM920	2401-000665	C-AL	2.2uF/50V	
21	CM921	2201-000262	C-CERA	180P	RADIAL
22	CM922	2401-000590	C-AL	1uF/50v	
23	CM923*	2201-000681	C-CERA	82P	NOT USED
24	CM924	2202-002037	C-CERA	104P	
	CM925	2202-002037	C	104P	
25	DM901	0401-000005	D	1N4148	
26	DM902	0401-000005	D	1N4148	
27	ICM901	1204-001058	IC	LA7337	
28	LM901	2701-000002	COIL	100uH	
29	LM902	2701-000162	COIL	27uH	
30	LM903	2701-000158	COIL	22uH	
31	LM904	2701-000191	COIL	47uH	

**5-6-2 SECAM BLOCK OPTION TABLE (Continued)**

NO	LOCA - NO	CODE - NO	DESCRIPTION	SPECIFICATION	REMARK
32	LM905	2701-000208	COIL	6.8uH	
33	LM906*	2701-000158	COIL	22uH	NOT USED
34	QM901	0501-000398	TR	C945	
35	QM902	0501-000142	TR	R2001	
36	QM903	0504-000119	TR	R1004	
37	QM904	0501-000398	TR	C945	
38	QM905	0501-000398	TR	C945	
39	QM906	0501-000303	TR	A733	
40	RM901	2001-000522	R	22K	
41	RM902	2001-000472	R	2.7K	
42	RM903	2001-000539	R	24K	
43	RM904	2001-000947	R	7.5K	
44	RM905	2001-000890	R	6.8K	
45	RM906	2001-000387	R	51K	
46	RM907	2001-000591	R	3.3K	
47	RM908	2001-000633	R	30K	
48	RM909	2001-000890	R	6.8K	
49	RM910	2001-000429	R	1K	
50	RM911	2001-000429	R	1K	
51	RM912	2001-000674	R	360	
52	RM913	2001-000281	R	100	
53	RM914	2001-000786	R	47K	
54	RM915	2001-000539	R	24K	
55	RM916	2001-001015	R	9.1K	
56	RM917	2001-000977	R	8.2K	
57	RM918	2001-000139	R	120K	
58	RM919	2001-000734	R	4.7K	
59	RM920	2001-000539	R	24K	
60	RM921	2001-000429	R	1K	
61	RM922*	2001-000319	R	120K	NOT USED
63	JM173	3812-000219	JUMPER	JUMPER	
64	JM174	3812-000219	JUMPER	JUMPER	
65	JM176	3812-000219	JUMPER	JUMPER	
66	JM179	3812-000219	JUMPER	JUMPER	
67	JM194	3812-000219	JUMPER	JUMPER	

## 6. Troubleshooting

### 6-1 No Power (No Picture on)

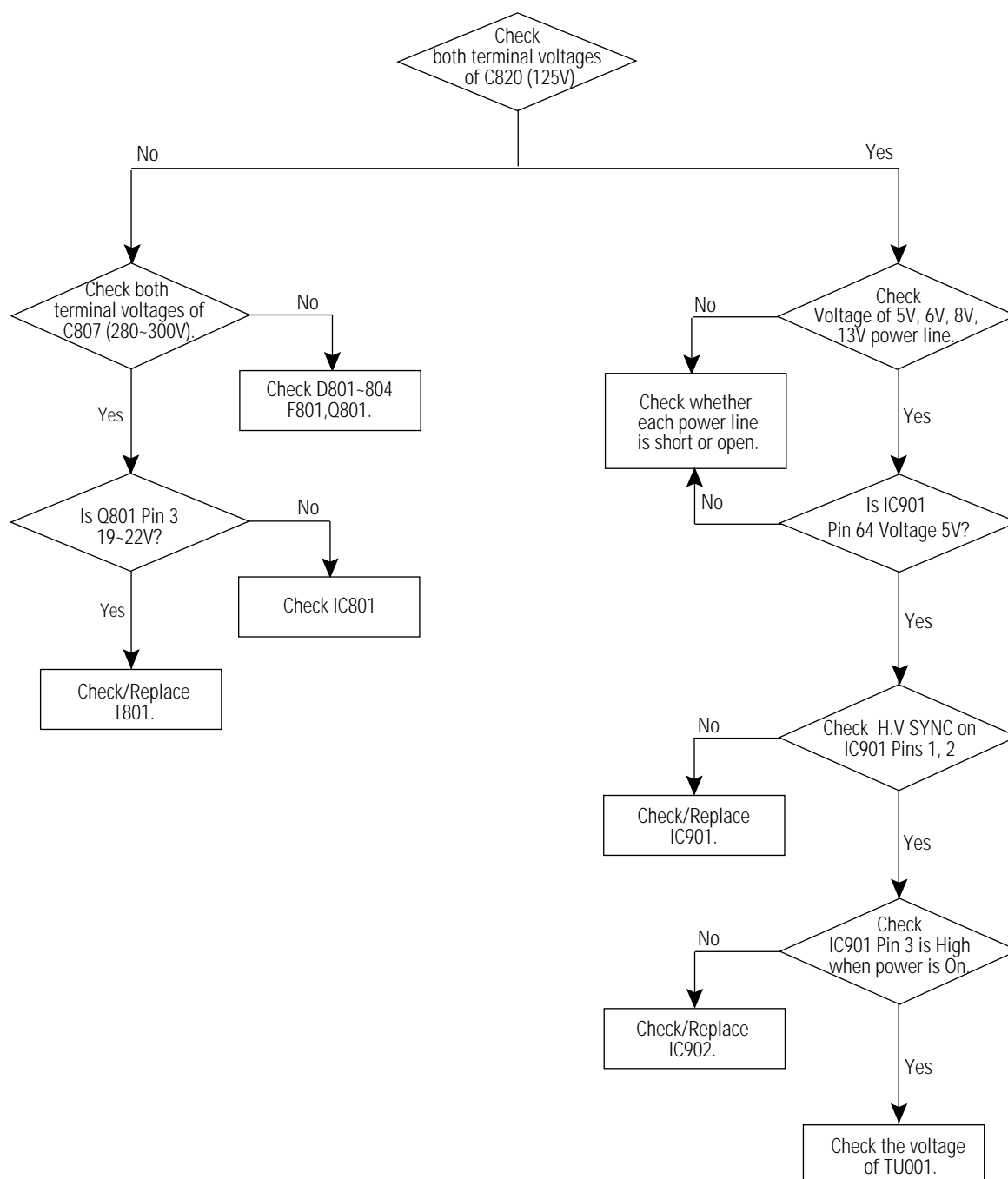

## 6-2 No Power (No LED On)

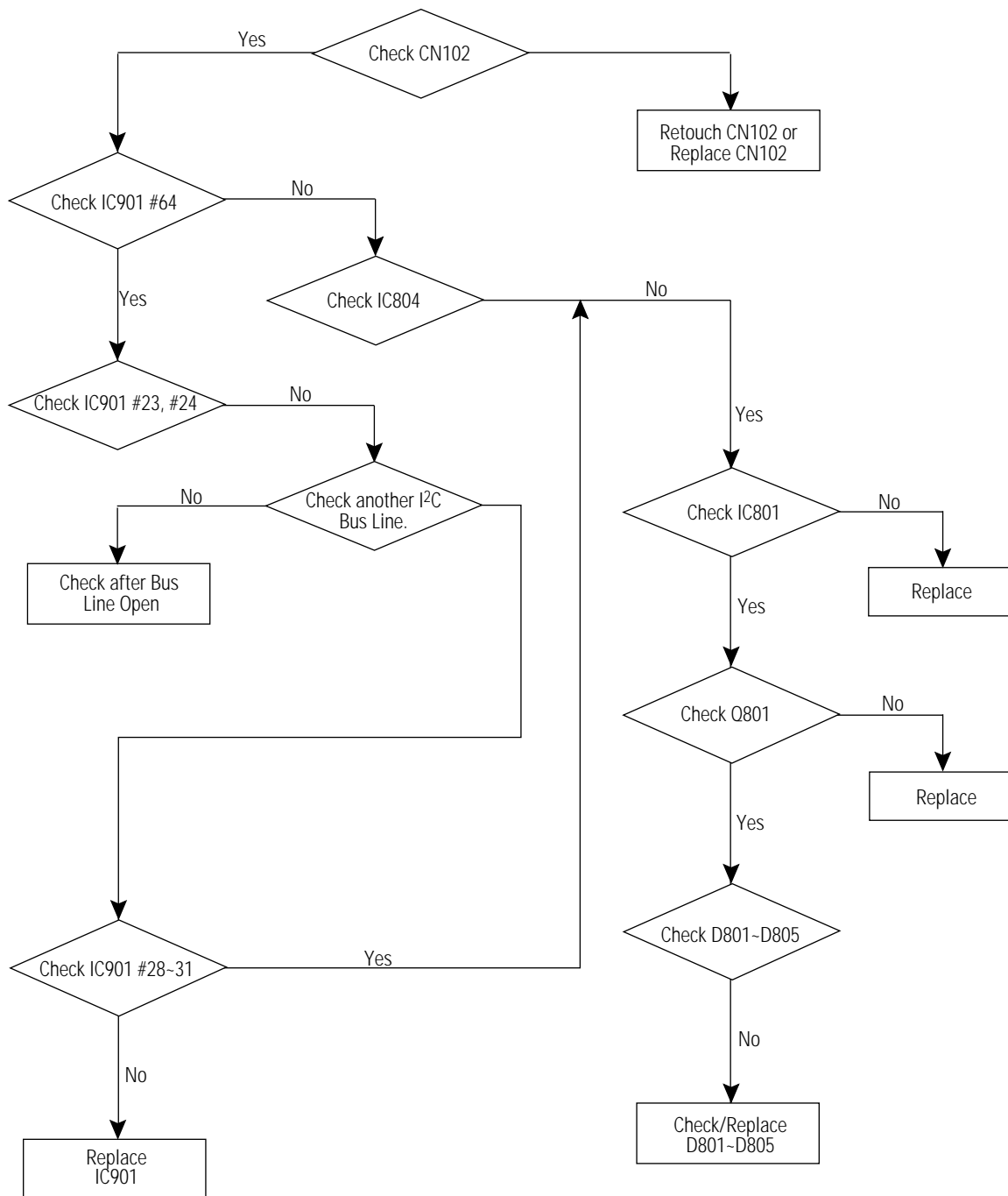

### 6-3 No RF Picture / Sound

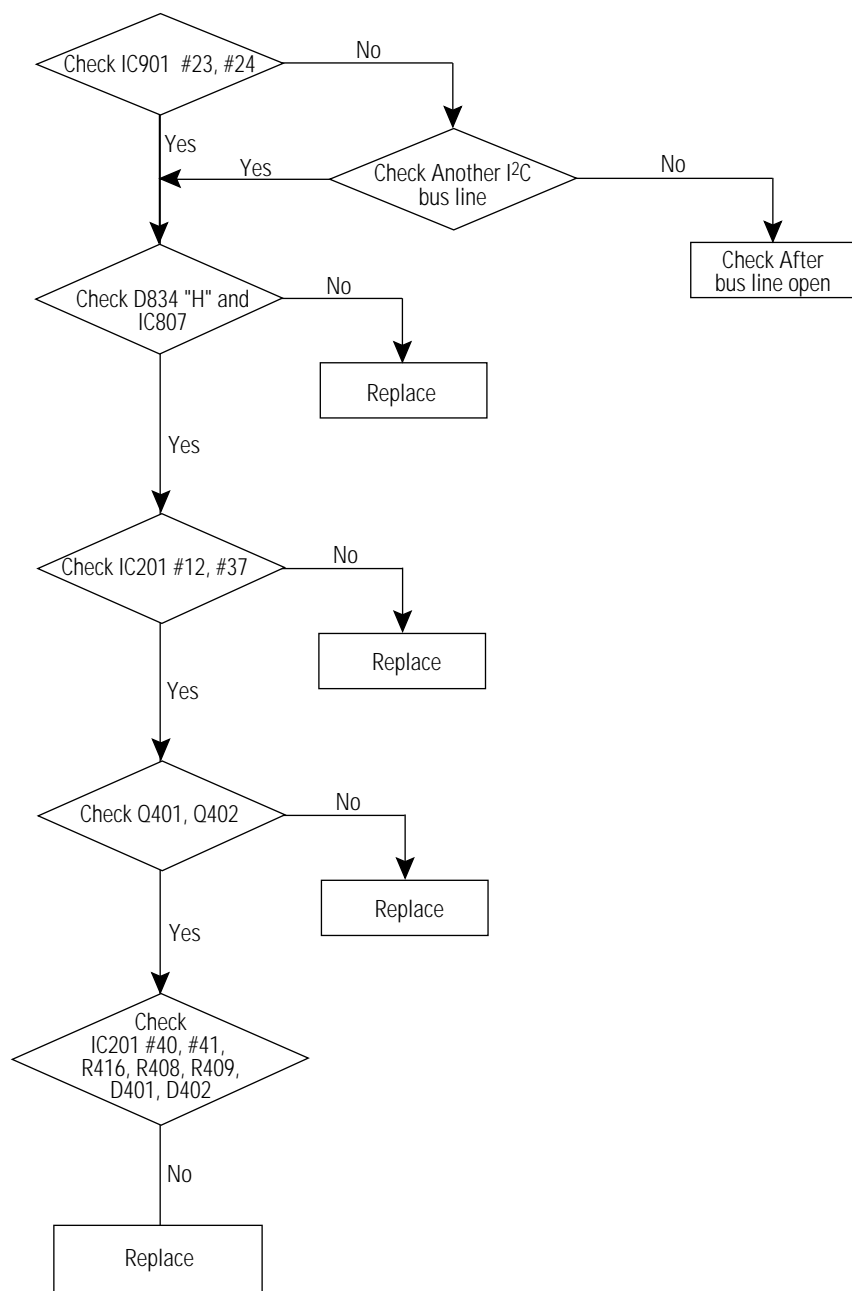

## **6-4 No Picture (Sound OK)**

---

1. Check the Brightness, Contrast and Color adjustments
2. Check: AV Picture, Video Playback
3. See Video Block Diagram

## **6-5 No Sound (Picture OK)**

---

1. Check the Volume adjustment level.
2. Check AV Video, Sound Playback
3. See Audio Block Diagram

## **6-6 RF Weak Signal (Playback, AV Mode OK)**

---

1. Check Tuner (TU001) B+. Check: 9V (IC807)  
33V (DZ803). Check 5V (IC902)
2. Pre AMP (HC001), B+. Check: 9V (IC807)

## **6-7 Recording Defect**

---

1. CN101 Check : Retouch
2. 2nd Tuner (TU002) B+. Check : 12V (D818), 33V(DZ803)  
5V (IC807)
3. 2nd If : Check 9V (IC806), Video out, Audio out
4. Video Defect : IC701 Check
5. Audio Defect : IC701 Check
6. Standby Recording Defect, IC901 #5 Line: Check (D833, IC804, IC807, IC806)
7. VPS (PDC) Recording Defect: Check IC901, #4

## 6-8 No Color

---

1. Check the Color Adjustment level
2. Check the Sandcastle Pulse Line : IC201 #41
3. Check the R-Y, B-Y Line : IC201 #29~#32
4. Check crystal : X202 (4.43361MHz)

## 6-9 No Vertical SCAN

---

1. Check R410, D404
2. Check IC301, #7
3. Check IC201 #46, #47 Line
4. Check DY Connector

## 6-10 Horizontal Size

---

1. Check C402 , C403 , L401 , L404

## 6-11 On-Screen Display Missing

---

1. Check IC901 #2  
(D921, Q901, DZ901)
2. Check IC901 #1 (R949, D919, DZ904)

## 6-12 No Teletext

---

1. Check IC201 #38, #23, #24, #25
2. Check the 1st 5V-Line (D817, DZ808, R823)
3. Check TIC01 #1 (Vcc : 5V)
4. Check TIC01 #8 (CVBS)
5. Check IC201 #26 (TTX F/B)

## 6-13 Play Mode Inoperative

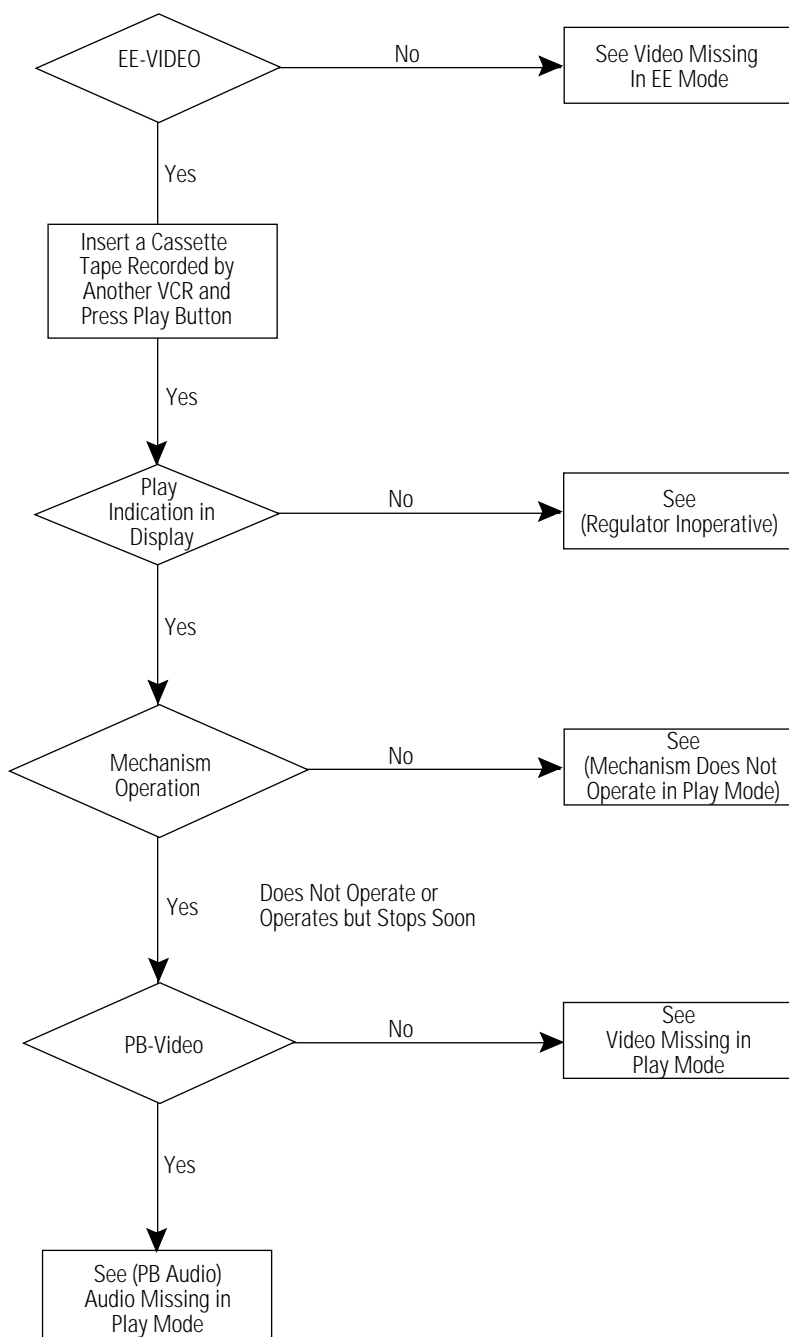

## 6-14 Mechanism Does Not Operate In Play Mode

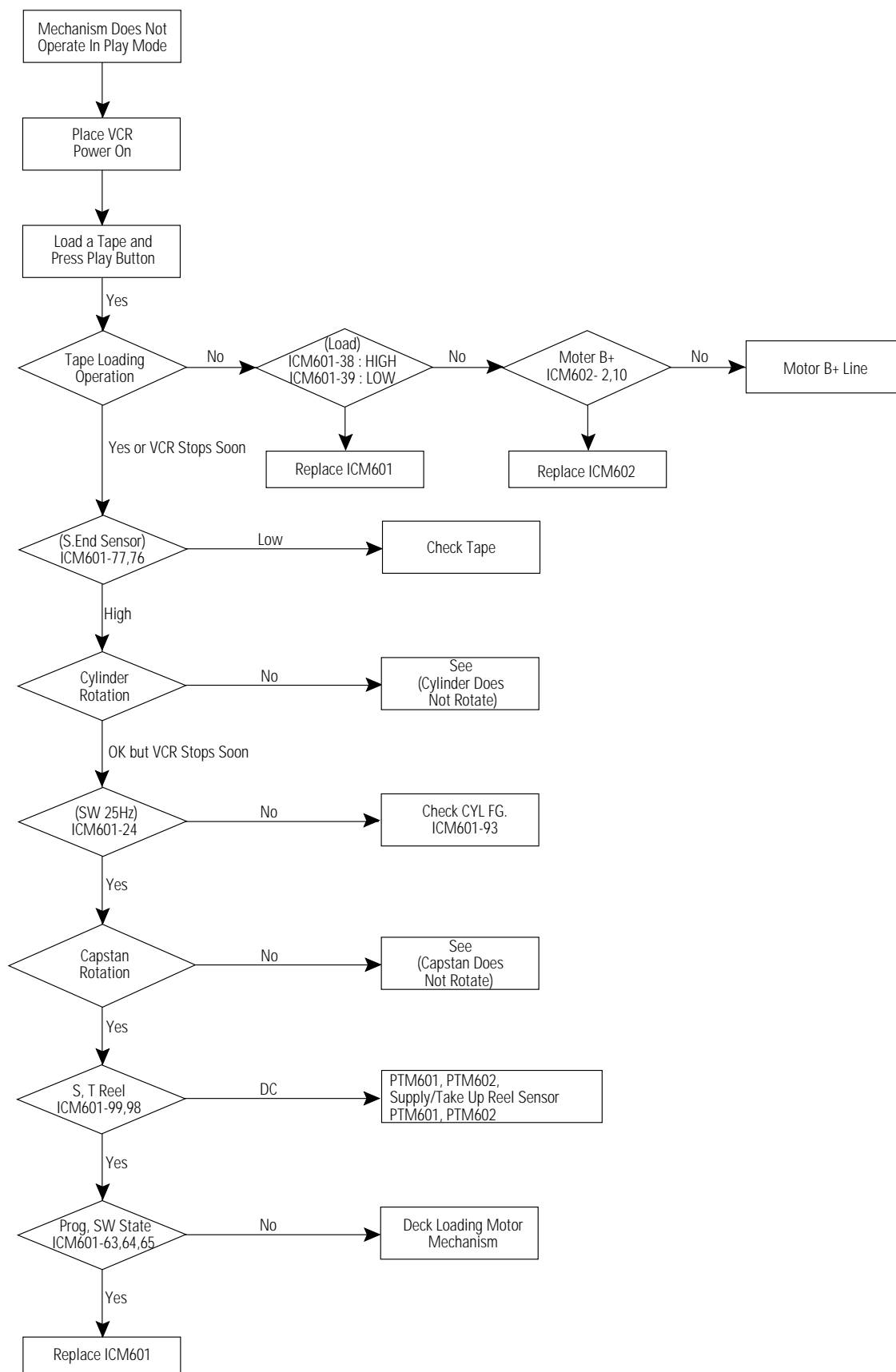

## 6-15 Record Mode Inoperative

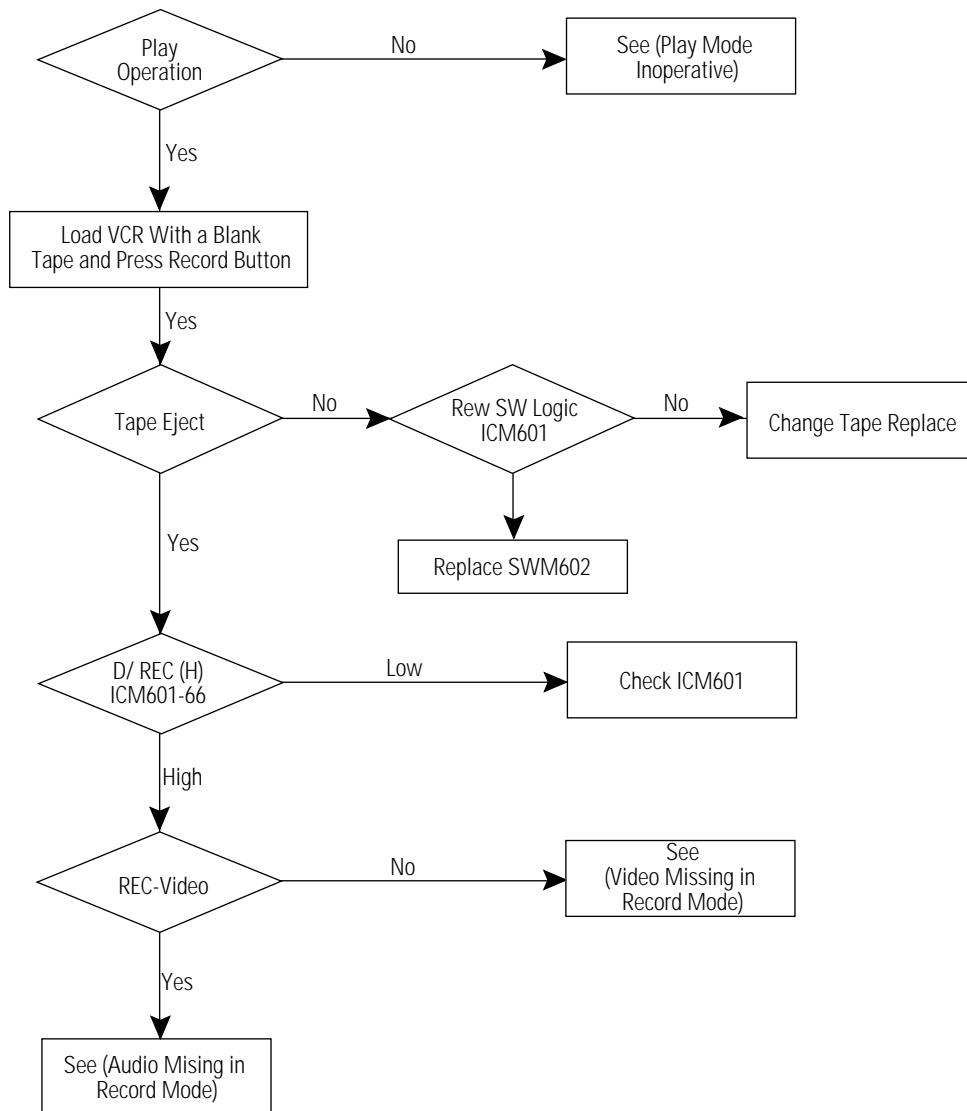

## 6-16 Fast Forward Mode Inoperative

---

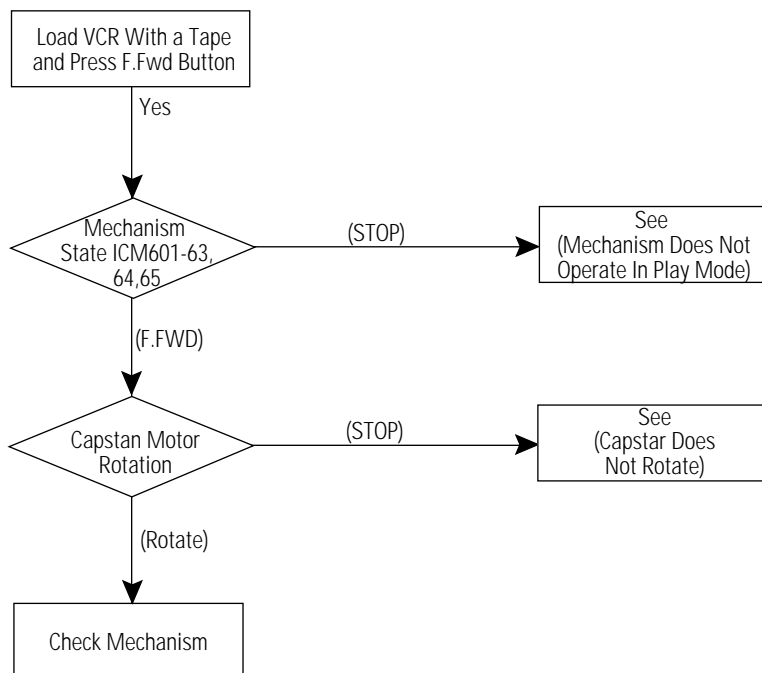

## 6-17 Rewind Mode Inoperative

---

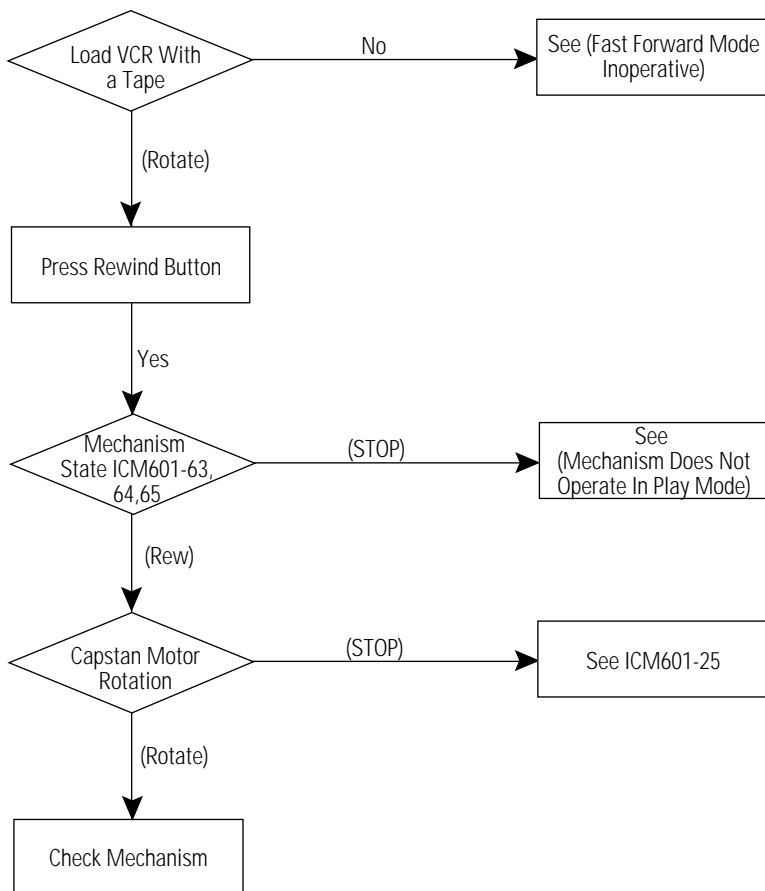

## 6-18 Rev Search Mode Inoperative

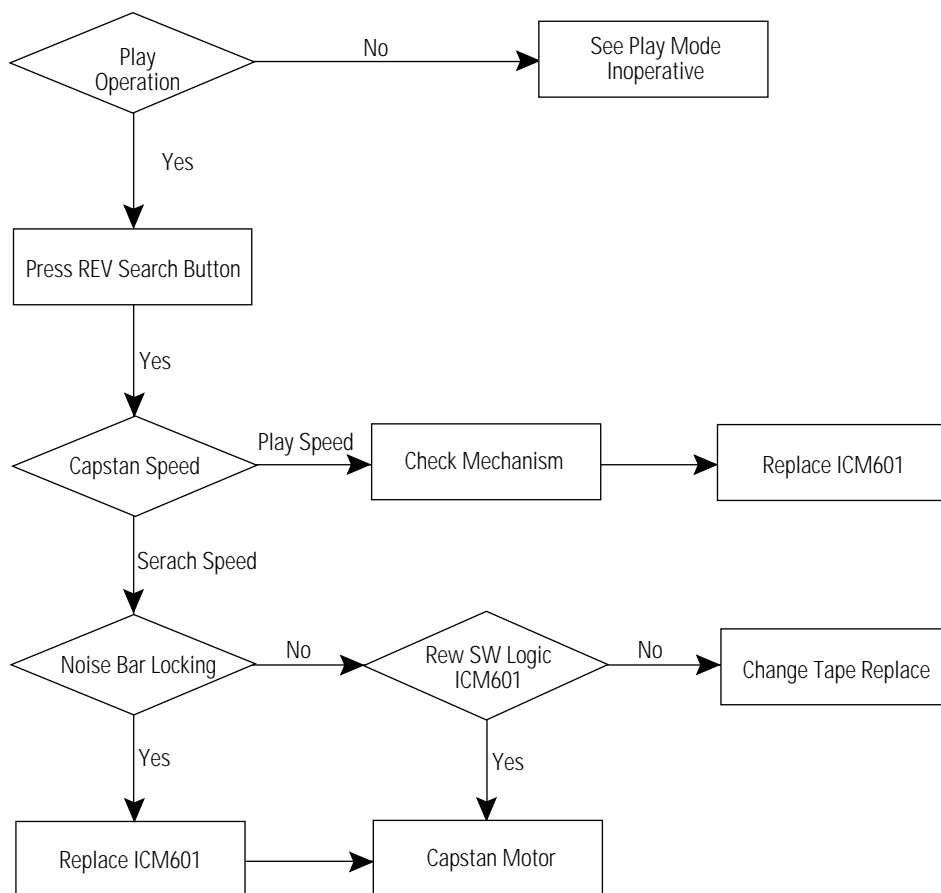

## 6-19 Cassette Loading Mechanism Does Not Operate

---

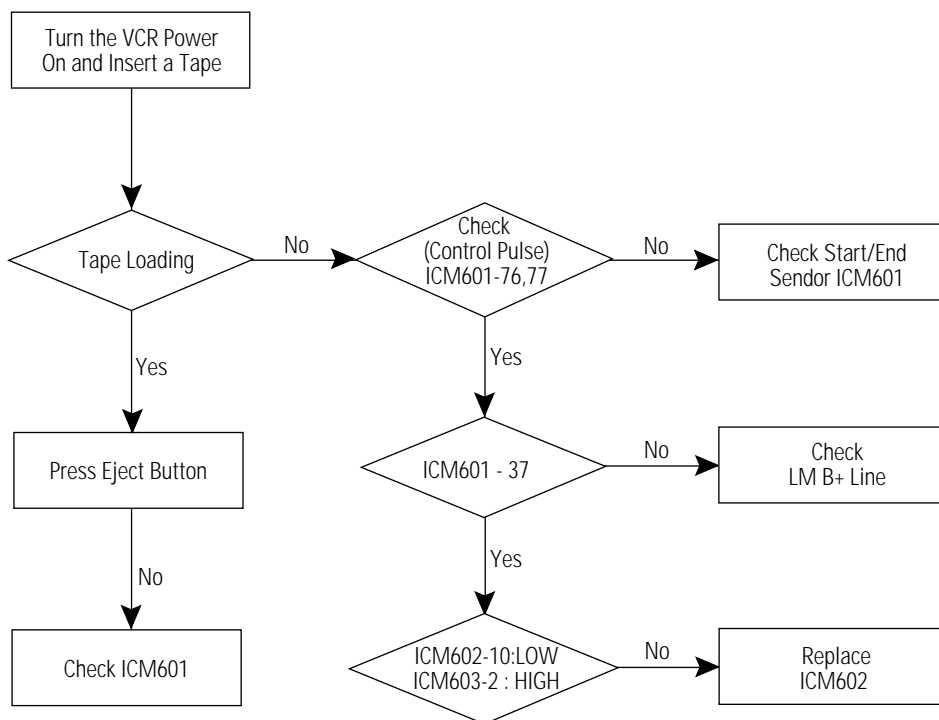

## 6-20 No Servo Lock

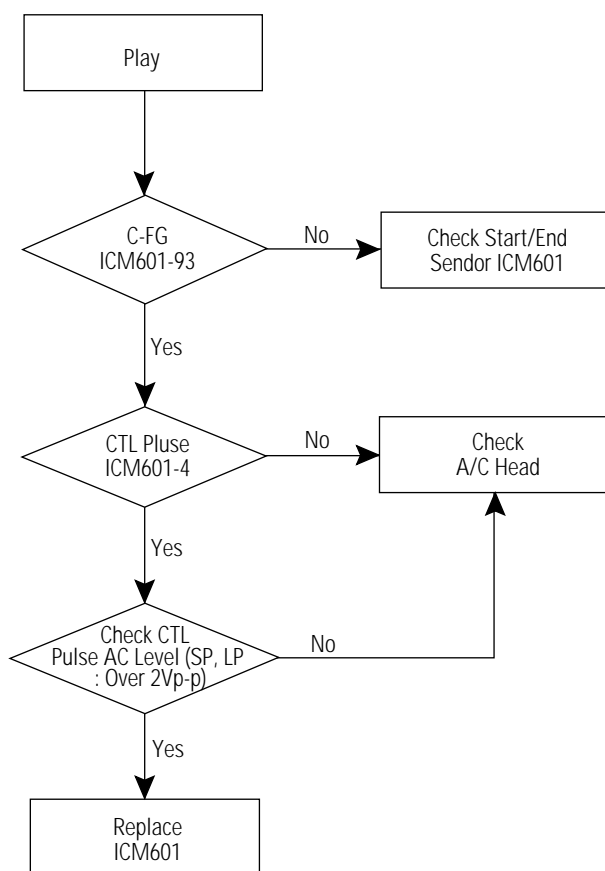

## 6-21 Capstan Does Not Rotate

---

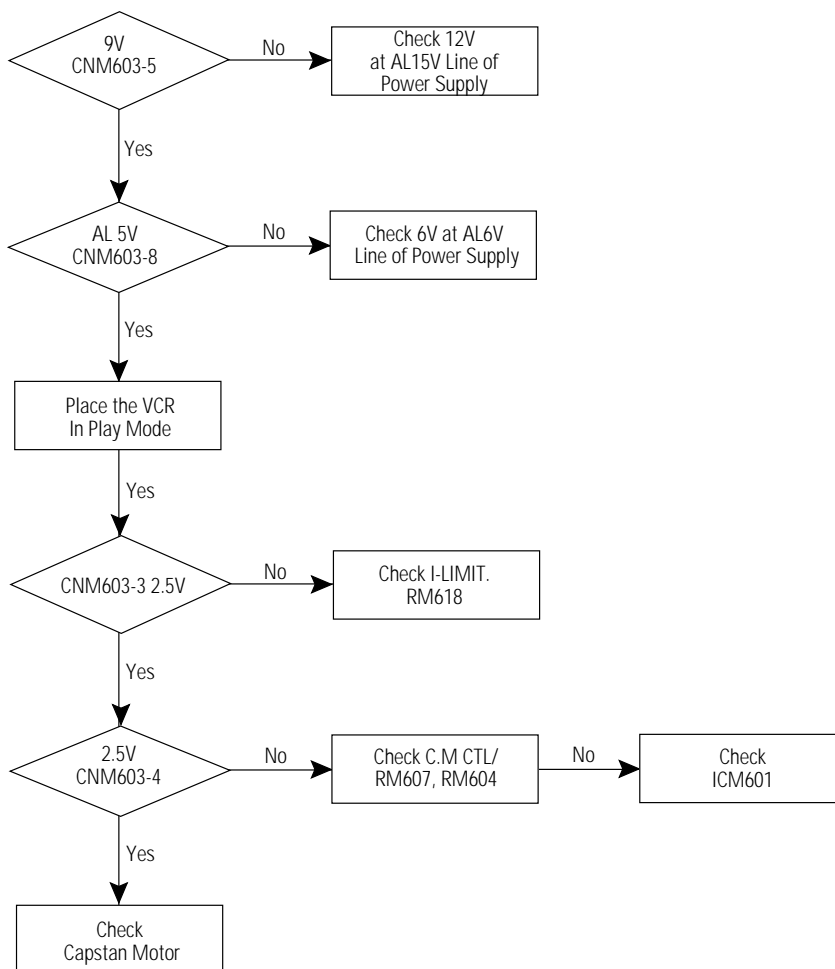

## 6-22 Drum Does Not Rotate

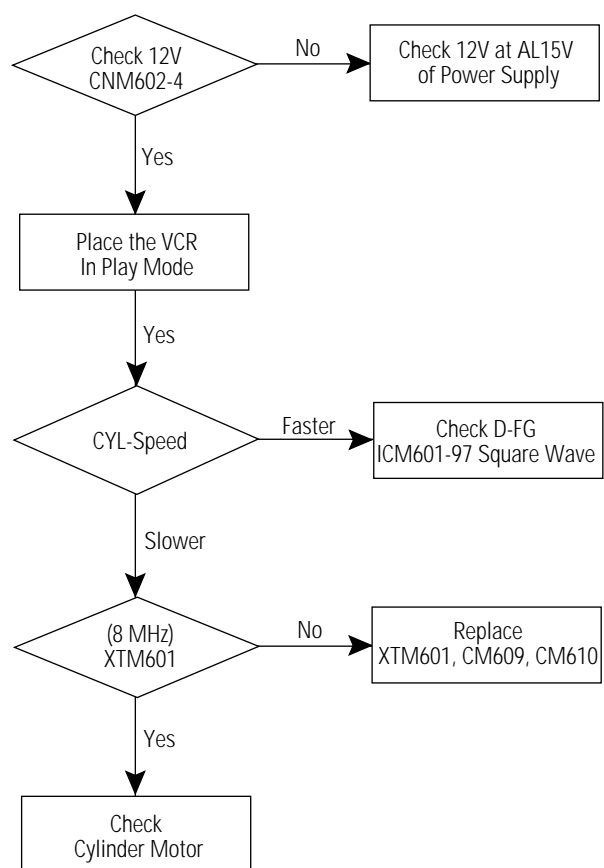

## 6-23 Video Missing In Play Mode

---

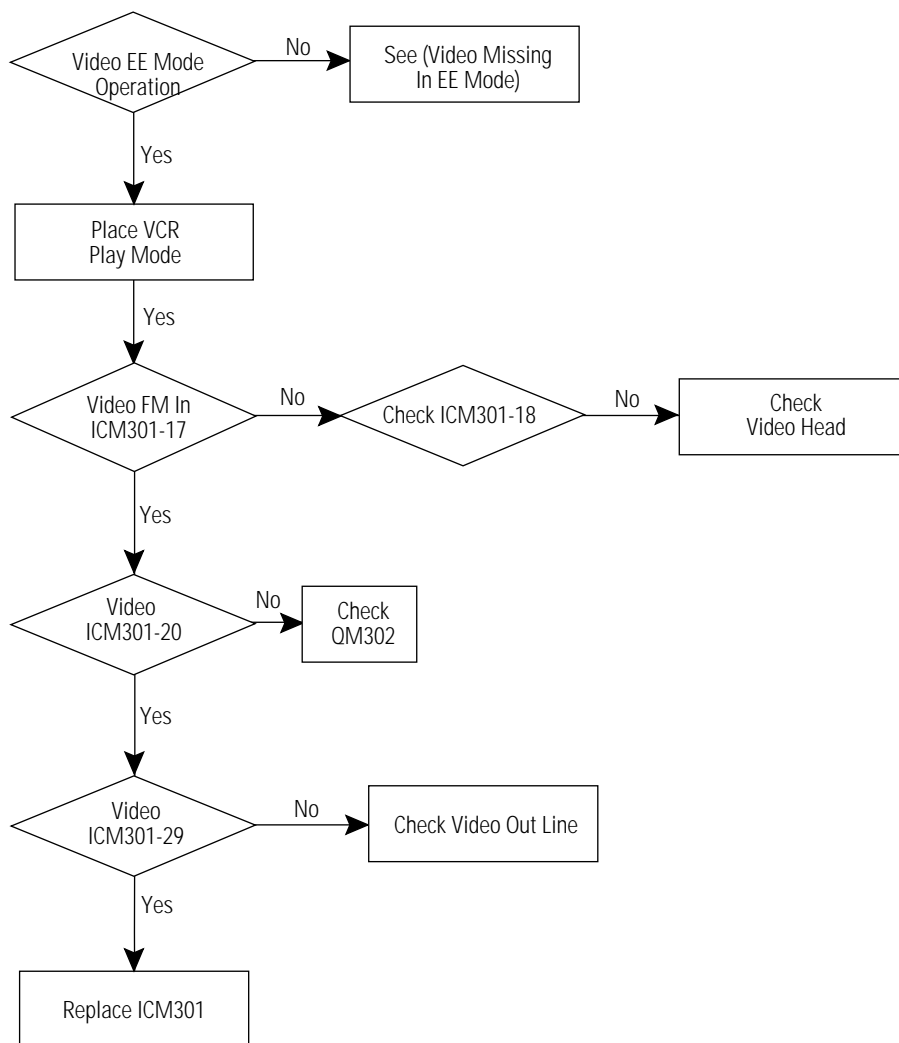

## 6-24 Video Missing In Record Mode

---

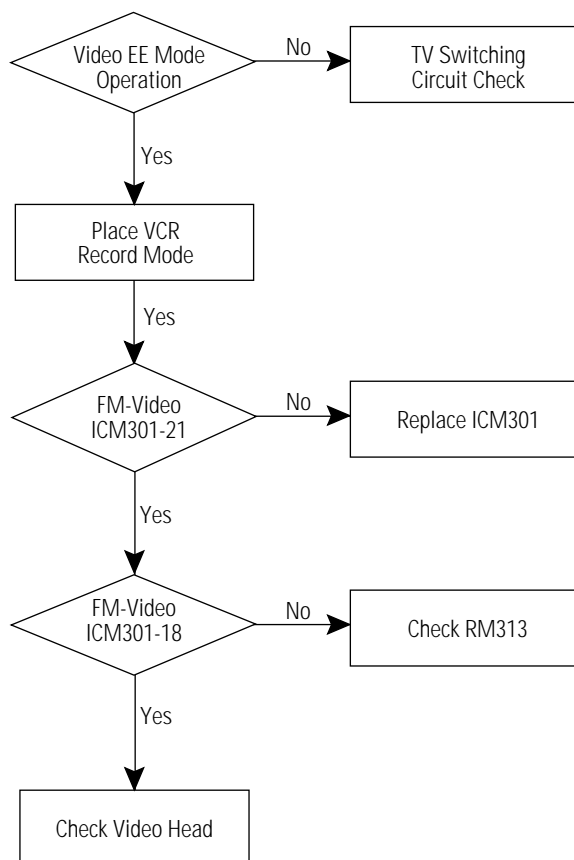

## 6-25 Color Missing In Play Mode

---

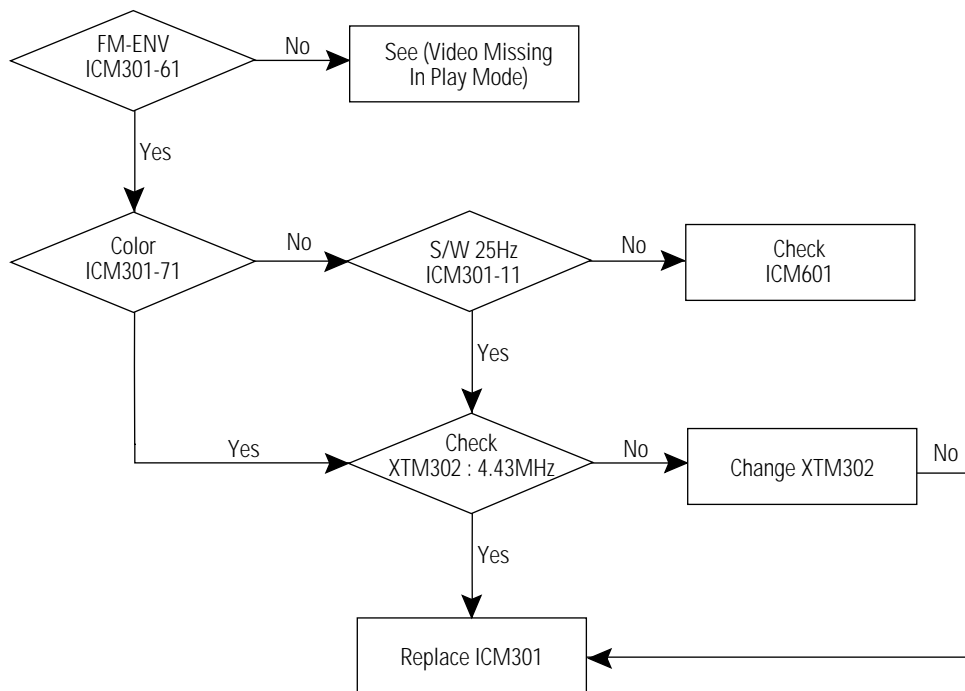

## 6-26 Color Missing In Record Mode

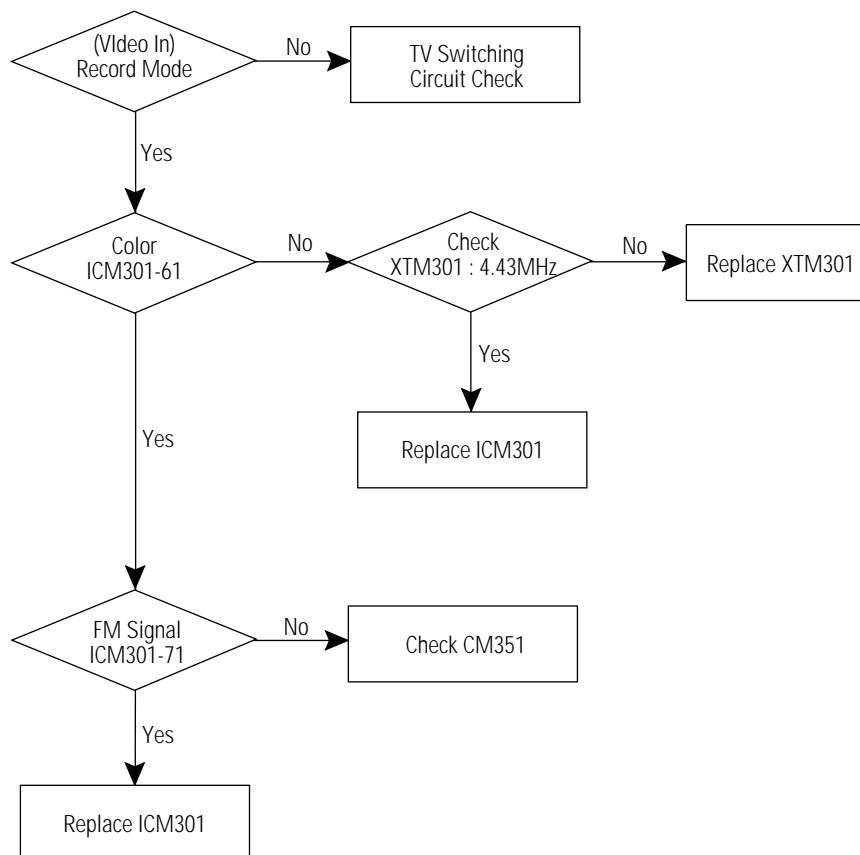

## 6-27 Audio Signal Missing in Play Mode

---

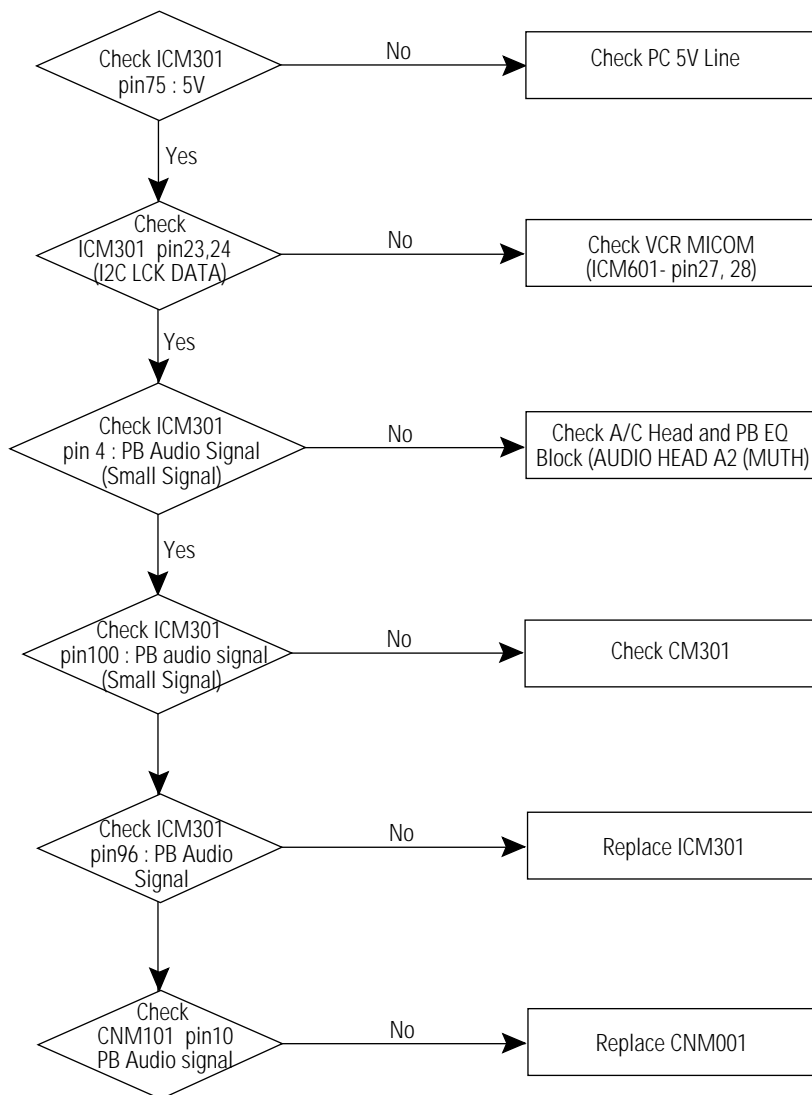

## 6-28 Audio Signal Missing After Recording

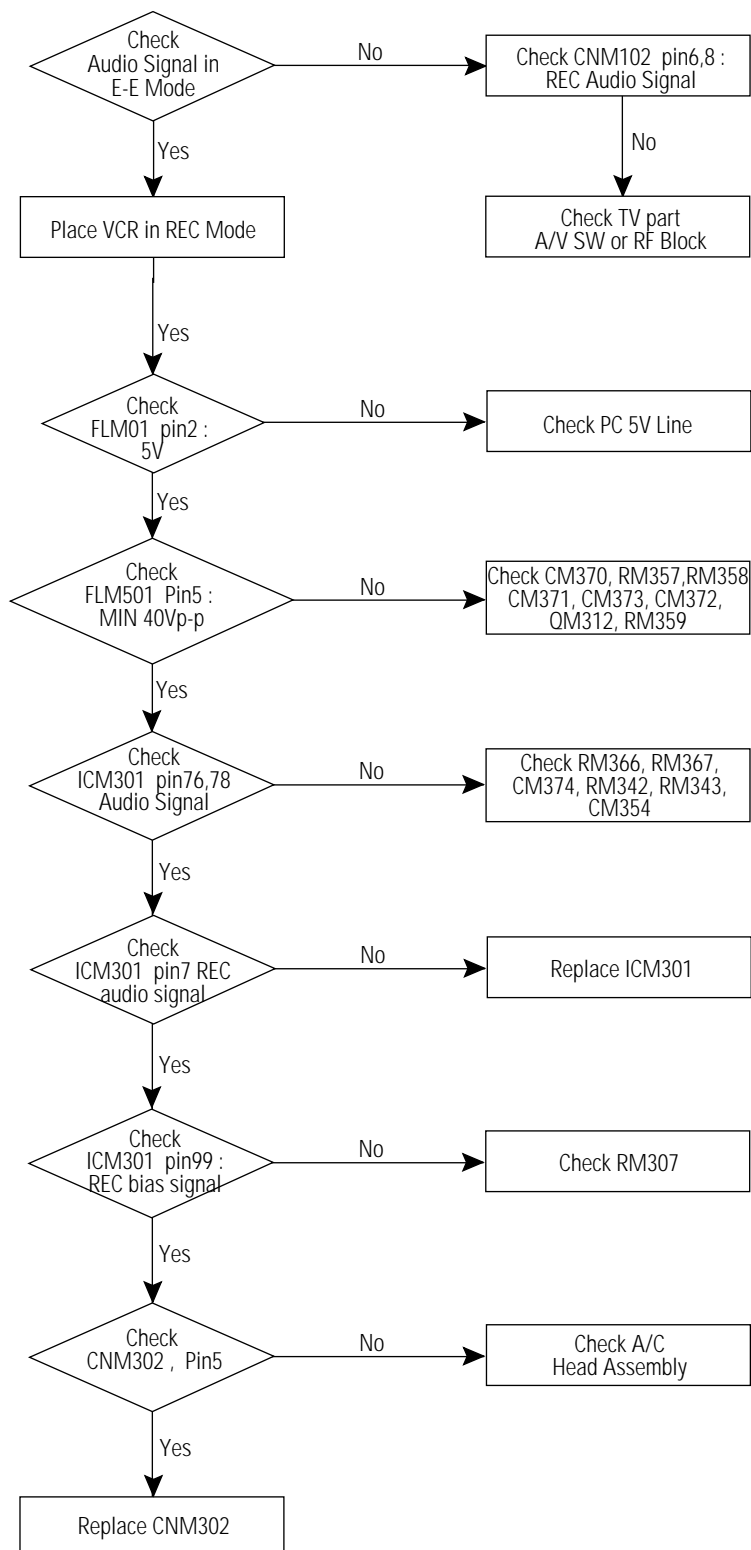

## 7. Exploded View & Parts List

### 7-1 TB14C52S/XEC

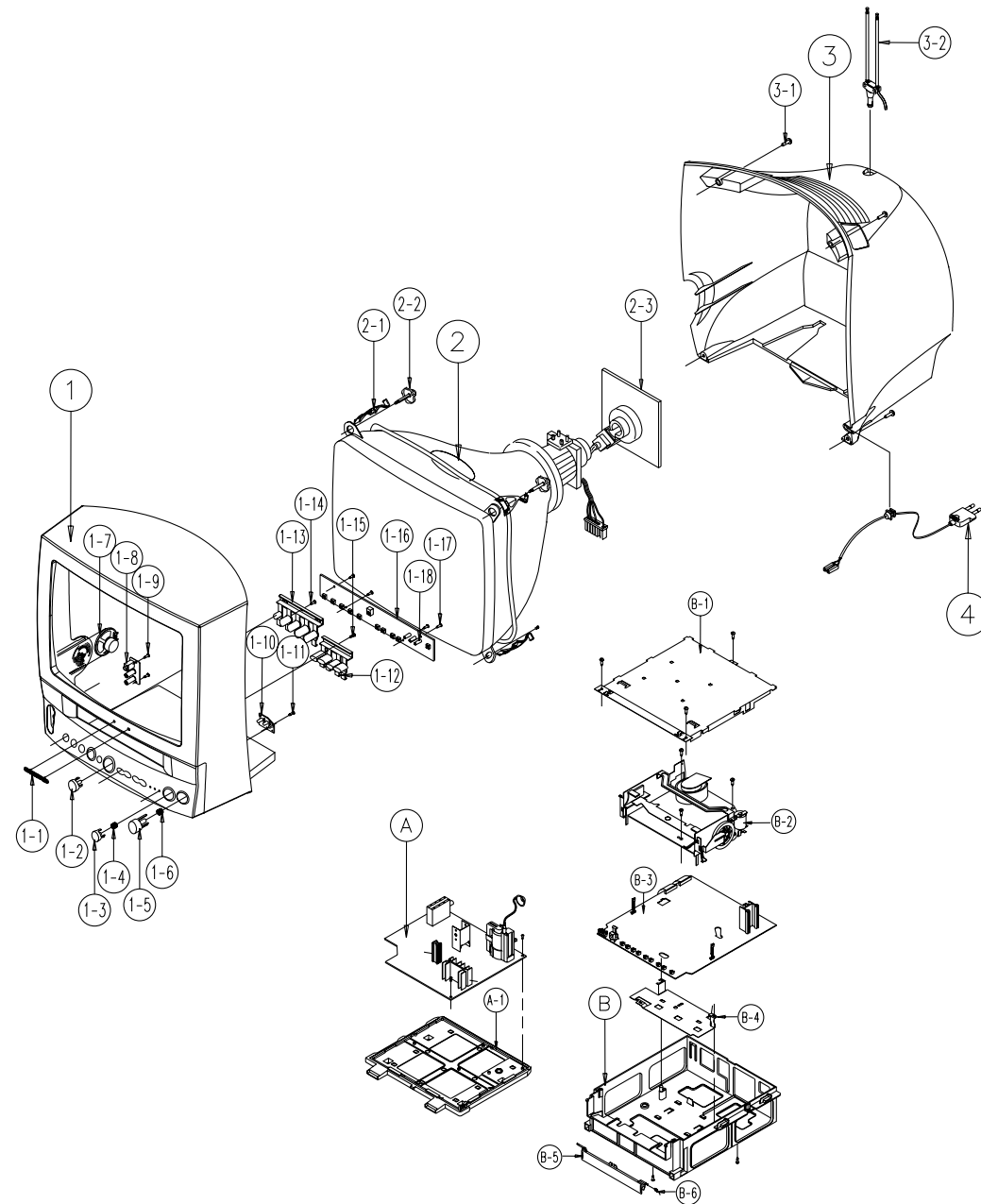

No	Code No	Description	Specification	Q'ty	Remark
1	AA90-00050B	ASSY-CABINET,FRONT	BK-708P ELN HB,14C5	1	
	AA64-31339E	CABINET-FRONT	-,14A5,C5,BK-708P,HIPS,HB,BLK,-,-	1	
1-1	AA64-70009B	BADGE-BRAND	AL,SS R2000 22,SILVER,L40,-,-,-	1	
1-2	AA64-00040A	WINDOW-REMOCON	-,TVN-504V,-,PC,-,VIOLET,-	1	
1-3	AA64-00038A	KNOB-MASTER	-,TVCR 14,20,M/S BK-708P,ABS,HB,BLK	1	
1-4	AA61-60003Q	SPRING-CS	-,SUS304,0.5,OD8,H10,N5,-,-,-	1	
1-5	AA64-00037B	KNOB-POWER	-,14C5,20C5,BK-708P TACT,ABS,HB,BLK	1	
1-6	AA61-60003E	SPRING-CS	-,SUS304,0.5,OD8,H9,N5,-,-,-	1	
1-7	3001-001015	SPEAKER	2.5W,16ohm,88dB,150Hz	1	
1-8	AA95-40012B	ASSY-PCB,A/V	DP,TF502,C15A,PAL,230V,14-21'	1	
1-9	6003-000333	SCREW-TAPTITE	RH,+2S,M3,L10,ZPC(YEL),SWRCH1	2	
1-10	AA64-00039A	INDICATOR-LED	-,,-,ABS,-,CLEAR,-	1	
1-11	6003-000333	SCREW-TAPTITE	RH,+2S,M3,L10,ZPC(YEL),SWRCH1	1	
1-12	AA64-00035B	KNOB-CONTROL,TV	-,14C5,20C5,BK-708P,ABS,HB,BLK	1	
1-13	AA64-00036B	KNOB-FAMILY	-,14C5,20C5,BK-708P SEA,ABS,HB,BLK	1	
1-14	6002-000512	SCREW-TAPPING	RH,+2,M4,L12,ZPC(BLK),SWRCH18	1	
1-15	6002-000512	SCREW-TAPPING	RH,+2,M4,L12,ZPC(BLK),SWRCH18	1	
1-16	AA95-00092A	ASSY-PCB,CONTROL	DP,C15A,14/20,ALL	1	
1-17	6003-000333	SCREW-TAPTITE	RH,+2S,M3,L10,ZPC(YEL),SWRCH1	4	
1-18	AA61-50044A	GUIDE-LED	-,ABS,V0,BLK,-,AIWA,-	3	
2		CRT-COLOR			LOCAL (SESA)
2-1	AA65-30016A	CLAMP-D,COIL	NYLON-66,V0,NTR,DADH-360 14,-	2	
2-2	AA60-10050R	SCREW-ASSY	WC,HH,+M5,L31.5,SWRCH18A,ZPC(-	4	
2-3	AA95-20010X	ASSY-PCB,CRT	-,C15A,14,EU,230V	1	
3	AA64-31340D	CABINET-BACK	-,14A5,C5,-,HIPS,V2,BLK,-,-	1	
3-1	6002-000514	SCREW-TAPPING	RH,+2,M4,L15,ZPC(BLK),SWRCH18	6	
3-2	AA42-10001V	ANT-ROD	-,3S,620mm,BRN,UL/CSA	1	
4		POWER-CORD			LOCAL (SESA)
A	AA94-00427A	ASSY-PCB,MAIN(OPT)	TB14C52S/XEC,C15A,SPAIN,SESA	1	
A-1	AA61-20163A	HOLDER-CHASSIS	-,T3350,ABS,V0,GRY,-	1	
B	AA90-40008K	ASSY-FRAME	TS-DECK,14C5 SESA ONLY	1	
	AA61-00004A	FRAME-DECK	-,TVN-502V,-,V2,-,BLK,-,-,-,-	1	
B-1	AA63-00012A	COVER-FRAME,TOP	-,TVCR,PAL,SECC,-,-,-,-,-	1	
B-2	AA91-40112A	ASSY-DECK	-,2HD,X-9 PAL SESA	1	
B-3	AA95-00091Q	ASSY-PCB,M/DECK	-,C15A,2HD,PAL/SEC/MESEC,-,NTPB,KEY	1	
B-4	AA63-40313A	SHIELD-BOTTOM	-,SPT,TO.5,-,TVN334V	1	
B-5	AA64-00024M	DOOR-HOUSING	-,TVCR 14,20,BK708P PAL TTX(X) EL,ABS,HB	1	
B-6	AA61-00050A	SPRING-DOOR	-,SUS304,-,-,-,-,0.5,OD6,H9.7,N8,TVCR T	1	

7-2 TB20C52S/XET

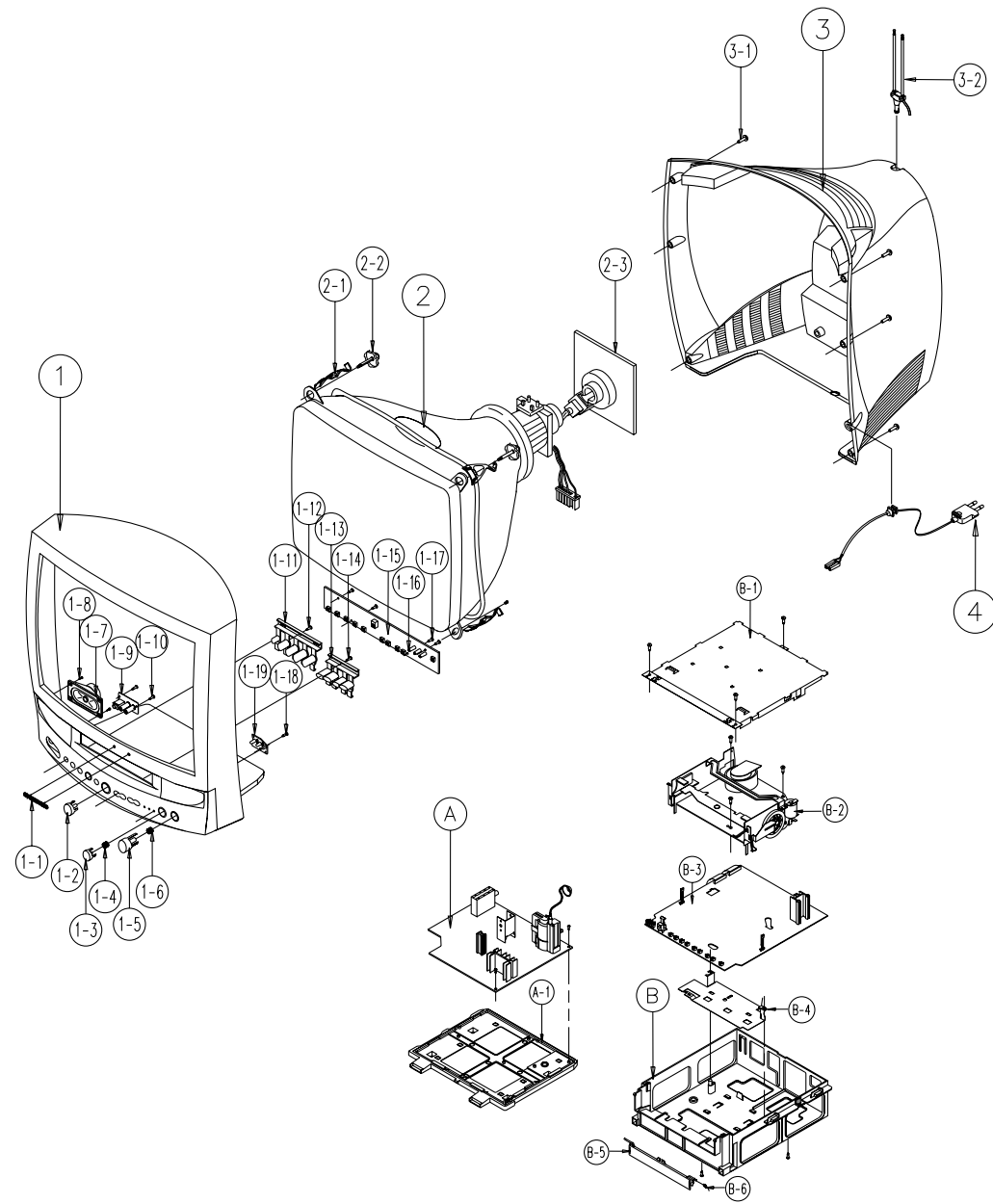

No	Code No	Description	Specification	Q'ty	Remark
1	AA90-00052B	ASSY-CABINET,FRONT	BK708P ELN HB BLK,20C5,SESA	1	
	AA64-00025C	CABINET-FRONT	-20A5,C5,BK-708P,HIPS,HB,BLK,-,-	1	
1-1	AA64-70010B	BADGE-BRAND	AL,SS R2000 25,SILVER,L50,-,-,-	1	
1-2	AA64-00040A	WINDOW-REMOCON	-,TVN-504V,-,PC,-,VIOLET,-	1	
1-3	AA64-00038A	KNOB-MASTER	-,TVCR 14.20,M/S BK-708P,ABS,HB,BLK	1	
1-4	AA61-60003Q	SPRING-CS	-,SUS304,0.5,OD8,H10,N5,-,-,-	1	
1-5	AA64-00037B	KNOB-POWER	-,14C5,20C5,BK-708P TACT,ABS,HB,BLK	1	
1-6	AA61-60003E	SPRING-CS	-,SUS304,0.5,OD8,H9,N5,-,-,-	1	
1-7	3001-001037	SPEAKER	5W,8ohm,89dB,180Hz	1	
1-8	6002-000514	SCREW-TAPPING	RH,+2,M4,L15,ZPC(BLK),SWRCH18	4	
1-9	AA95-40012B	ASSY-PCB,A/V	DP,TF502,C15A,PAL,230V,14-21'	1	
1-10	6003-000333	SCREW-TAPTITE	RH,+2S,M3,L10,ZPC(YEL),SWRCH1	2	
1-11	AA64-00036B	KNOB-FAMILY	-,14C5,20C5,BK-708P SEA,ABS,HB,BLK	1	
1-12	6002-000514	SCREW-TAPPING	RH,+2,M4,L15,ZPC(BLK),SWRCH18	1	
1-13	AA64-00035B	KNOB-CONTROL,TV	-,14C5,20C5,BK-708P,ABS,HB,BLK	1	
1-14	6002-000514	SCREW-TAPPING	RH,+2,M4,L15,ZPC(BLK),SWRCH18	1	
1-15	AA95-00092A	ASSY-PCB,CONTROL	DP,C15A,14/20,ALL	1	
1-16	AA61-50044A	GUIDE-LED	-,ABS,V0,BLK,-,AIWA,-	3	
1-17	6003-000333	SCREW-TAPTITE	RH,+2S,M3,L10,ZPC(YEL),SWRCH1	4	
1-18	6003-000333	SCREW-TAPTITE	RH,+2S,M3,L10,ZPC(YEL),SWRCH1	1	
1-19	AA64-00039A	INDICATOR-LED	-,ABS,-,CLEAR,-	1	
2		CRT-COLOR			LOCAL (SESA)
2-1	AA65-30107A	CLAMP-D,COIL	NYLON 66,V2,NTR,-20-22 INCH,-	4	
2-2	AA60-10050R	SCREW-ASSY	WC,HH,+M5,L31.5,SWRCH18A,ZPC(	4	
2-3	AA95-20011A	ASSY-PCB,CRT	-,C15A,20,21,EC,-	1	
3	AA64-00016C	CABINET-BACK	-,20A5,C5,-,HIPS,V2,BLK,-,-	1	
3-1	6002-000514	SCREW-TAPPING	RH,+2,M4,L15,ZPC(BLK),SWRCH18	6	
3-2		ANT-ROD			LOCAL (SESA)
4		POWER-CORD			LOCAL (SESA)
A	AA94-00360A	ASSY-PCB,MAIN(OPT)	TF20C52S/XEF,C15A,FRANCE,SEF	1	
A-1	AA61-20021A	HOLDER-CHASSIS	-,T5050,ABS,V0,GRY,-	1	
B	AA90-40008D	ASSY-FRAME	TS-DECK,PAL SESA 20,21	1	
	AA61-00004A	FRAME-DECK	-,TVN-502V,-,V2,-,BLK,-,-,-,-	1	
B-1	AA63-00012A	COVER-FRAME,TOP	-,TVCR,PAL,SECC,-,-,-,-	1	
B-2	AA91-40112A	ASSY-DECK	-,2HD,X-9 PAL SESA	1	
B-3	AA95-00091V	ASSY-PCB,M/DECK	-,C15A,2HD,PAL,-,NTPB,KEY	1	
B-4	AA63-40313A	SHIELD-BOTTOM	-,SPT,TO.5,-,TVN334V	1	
B-5	AA64-00024W	DOOR-HOUSING	-,14,20,BK708P EL TTX,2TUN,ABS,HB,BL	1	
B-6	AA61-00050A	SPRING-DOOR	-,SUS304,-,-,-,-,0.5,OD6,H9.7,N8,TVCR T	1	

7-3 TB21B5DF2S/XEC

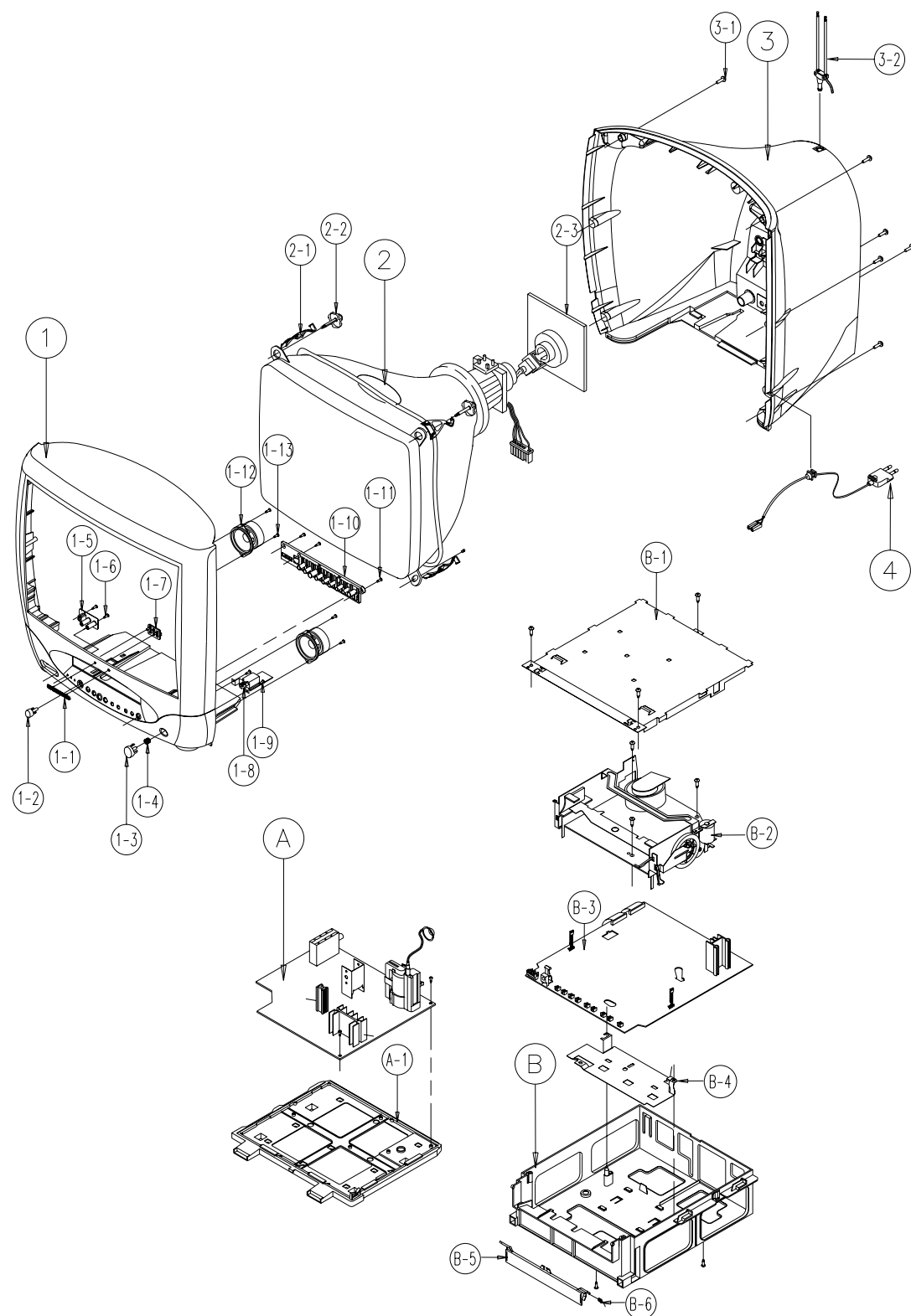

No	Code No	Description	Specification	Q'ty	Remark
1	AA91-00022A	ASSY-CABINET,FRONT	DP,21B5 ELN,(SPK) GR801P+DG703P,HB	1	
	AA64-31343B	CABINET-FRONT	-,21B5 GUJU,GR801P+DG703P,HIPS,HB,	1	
1-1	AA64-70010B	BADGE-BRAND	AL,SS R2000 25,SILVER,L50,-,-,-	1	
1-2	AA64-40522B	WINDOW-REMOCON	-,21B5,-,PC,VIOLET,-,-	1	
1-3	AA64-10799B	KNOB-MASTER	-,21B5,DG703P,ABS,HB,G3676	1	
1-4	AA61-60003Q	SPRING-CS	-,SUS304,0.5,OD8,H10,N5,-,-,-	1	
1-5	AA95-40012B	ASSY-PCB,A/V	DP,TF502,C15A,PAL,230V,14-21'	1	
1-6	6003-000333	SCREW-TAPTITE	RH,+2S,M3,L10,ZPC(YEL),SWRCH1	2	
1-7	AA64-40523B	INDICATOR-LED	-,21B5,-,PC,CLEAR,-,-	1	
1-8	AA95-00093A	ASSY-PCB,MASTER	DP,-,C15A,PAL,-,ALL	1	
1-9	6001-000677	SCREW-MACHINE	RH,+M3,L6,ZPC(YEL),SM20C,-	2	
1-10	AA64-10800B	KNOB-FAMILY	-,21B5,DG703P,ABS,HB,G3676	1	
1-11	6002-000514	SCREW-TAPPING	RH,+2,M4,L15,ZPC(BLK),SWRCH18	3	
1-12	3001-001087	SPEAKER	5W,16OHM,90°±2DB,250+50HZ	2	
1-13	6002-000514	SCREW-TAPPING	RH,+2,M4,L15,ZPC(BLK),SWRCH18	4	
2		CRT-COLOR			LOCAL (SESA)
2-1	AA65-30107A	CLAMP-D,COIL	NYLON 66,V2,NTR,-,20-22 INCH,-	4	
2-2	AA60-10050R	SCREW-ASSY	WC,HH,+M5,L31.5,SWRCH18A,ZPC(	4	
2-3	AA95-20011A	ASSY-PCB,CRT	-,C15A,20,21,EC,-	1	
3	AA64-31344E	CABINET-BACK	-,21B5,-,HIPS,V2,BLK,-,-	1	
3-1	6002-000514	SCREW-TAPPING	RH,+2,M4,L15,ZPC(BLK),SWRCH18	6	
3-2		ANT-ROD			LOCAL (SESA)
4		POWER-CORD			LOCAL (SESA)
A	AA94-00511A	ASSY-PCB,MAIN(OPT)	TB21B5DF2S/XEC,C15A,SPAIN,SECA	1	
A-1	AA61-20021A	HOLDER-CHASSIS	-,T5050,ABS,V0,GRY,-	1	
B	AA90-40008D	ASSY-FRAME	TS-DECK,PAL SESA 20,21	1	
	AA61-00004A	FRAME-DECK	-,TVN-502V,-,V2,-,BLK,-,-,-,-	1	
B-1	AA63-00012A	COVER-FRAME, TOP	-,TVCR,PAL,SECC,-,-,-,-	1	
B-2	AA91-40112A	ASSY-DECK	-,2HD,X-9 PAL SESA	1	
B-3	AA95-00091K	ASSY-PCB,M/DECK	-,-,C15A,2HD,PAL,-,NTPB	1	
B-4	AA63-40313A	SHIELD-BOTTOM	-,SPT,TO.5,-,TVN334V	1	
B-5	AA64-00024H	DOOR-HOUSING	-,21B5,DG703P S/VIEW 2TUN,ABS,HB	1	
B-6	AA61-00050A	SPRING-DOOR	-,SUS304,-,-,-,-,0.5,OD6,H9.7,N8,TVCR T	1	

### 7-4 Mechanical Parts (Top Side)

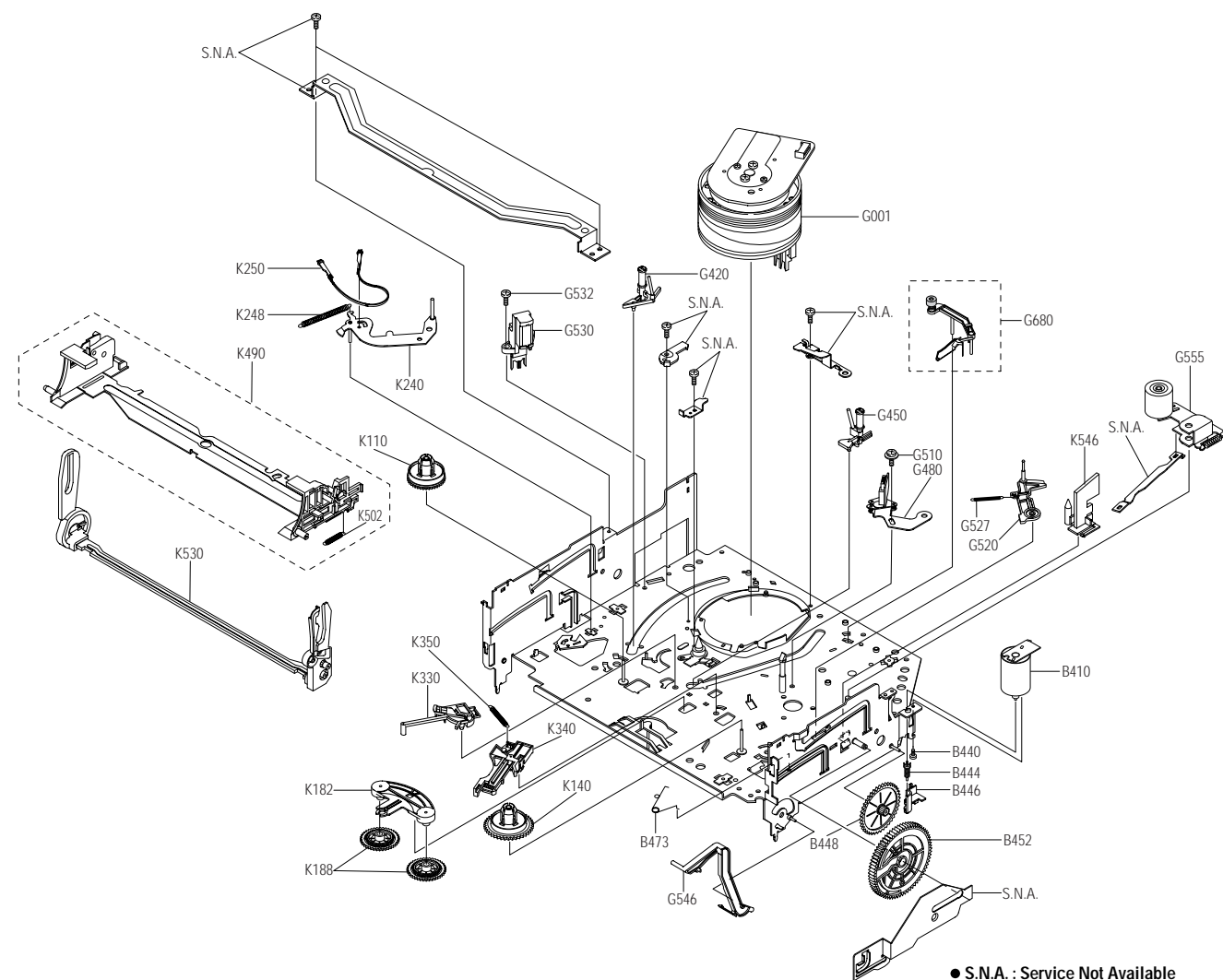

Loc. No	Part No	Description and Specification	Remark
B410	AC31-12016A	MOTOR-LOADING ASSY,-,X-9	
B440	AC60-10515A	SCREW-MACHINE-PH,+,-,M3,L3,ZPC,-,YEL	
B444	AC66-20571A	GEAR-WORM-POM SW-01,0.5,2,-,4.5,X-9	
B446	AC61-21005A	HOLDER-WORM-POM M90-44,-,-,X-9	
B448	AC66-20573A	GEAR-WORM WHEEL-POM SW-01,0.6,11,-,6.6	
B452	AC66-20575A	GEAR-FL CAM-POM SW-01,M0.6,Z88,-,PCD58	
B473	AC61-60559A	SPRING-PINCH DRIVE-TS,SUS304,PI0.5,OD4	
G001	AC96-10481K	ASSY-CYLINDERCX-9, NTSC 6HD	(6HD NON-DIAMOND HEAD)
	AC96-10481H	ASSY-CYLINDERCX-9, NTSC 4HD	(4HD NON-DIAMOND HEAD)
	AC96-10481F	ASSY-CYLINDERCX-9, NTSC 2HD	(2HD NON-DIAMOND HEAD)
	AC96-10482N	ASSY-CYLINDERCX-9, NTSC 6HD/DLC	(6HD DIAMOND HEAD)
	AC96-10482G	ASSY-CYLINDERCX-9, NTSC 4HD/DLC	(4HD DIAMOND HEAD)
	AC96-10482C	ASSY-CYLINDERCX-9, NTSC 2HD/DLC	(2HD DIAMOND HEAD)
G420	AC66-80142A	SLIDER-SUPPLY ASSY-X-9(TS),-,-,X-9	
G450	AC66-80141A	SLIDER-TAKE UP ASSY-X-9(TS),-,-,X-9	
G480	AC33-10217H	HEAD-ACE ASSY,-,-,X-9	
G510	AC60-10518A	SCREW-TAP TITE-PH,+SW+ZW,M2.6,L5.6,ZP	
G520	AC66-30539A	LEVER-#9 GUIDE ASSY-X-9(TS),-,-,X-9	
G527	AC61-60553A	SPRING-#9 GUIDE-ES,SUS304-WPB,OD3.1,0.	
G530	AC33-10217G	HEAD-FEVAA00000275,-,-,X-9	
G532	AC60-10519A	SCREW-TAP TITE-PH,+,-,M2.6,L8,ZPC	
G546	AC66-30535A	LEVER-FL DOOR-POM M90-44,-,-,BLK,X-9	
G555	AC59-90403A	UNIT-PINCH ASSYX-9,-	
G680	AC66-30557A	LEVER-H/CLEANER ASSY,POM+URETHANE,-,-	(OPTIONAL)
K110	AC66-10267A	REEL-DISK S-POM M90-44,-,-,X-9	
K140	AC66-10268A	REEL-DISK T-POM M90-44,-,-,X-9	
K182	AC66-30524A	LEVER-IDLER-POM9044,-,-,X-9	
K188	AC66-20577A	GEAR-IDLER-PEBAX 7033,-,-,X-9	
K240	AC66-30538A	LEVER-TENSION ASSY-X-9(TS),-,-,X-9	
K248	AC61-60554A	SPRING-TENSION LEVER-ES,SUS304-WPB,OD3	
K250	AC63-12029A	BAND-BRAKE ASSY-X-9(TS),-,-,X-9	
K330	AC66-30550A	LEVER-S.BRAKE ASSY,POM+SUS,-,-,X-9	
K340	AC66-30549A	LEVER-T.BRAKE ASSY,POM+SUS,-,-,X-9	
K350	AC61-60564A	SPRING-BRAKE-TENSION,SWP-A,0.25,3,-,X-	
K490	Refer to table below	HOLDER-CASS ASSY-SECC+POM+SUS,-,-,X-	
K502	AC61-60561A	SPRING-FL.LEVER-LR-ES,SUS304 WPB,PI2.7	
K530	AC66-30546A	LEVER-FL.ARM ASS'Y,SECC+POM+SUS,-,-,	
K546	AC61-50658A	GUIDE-CASS. DOOR-POM M90-44,-,-,NTR,-,	

### 7-5 Mechanical Parts (Bottom Side)

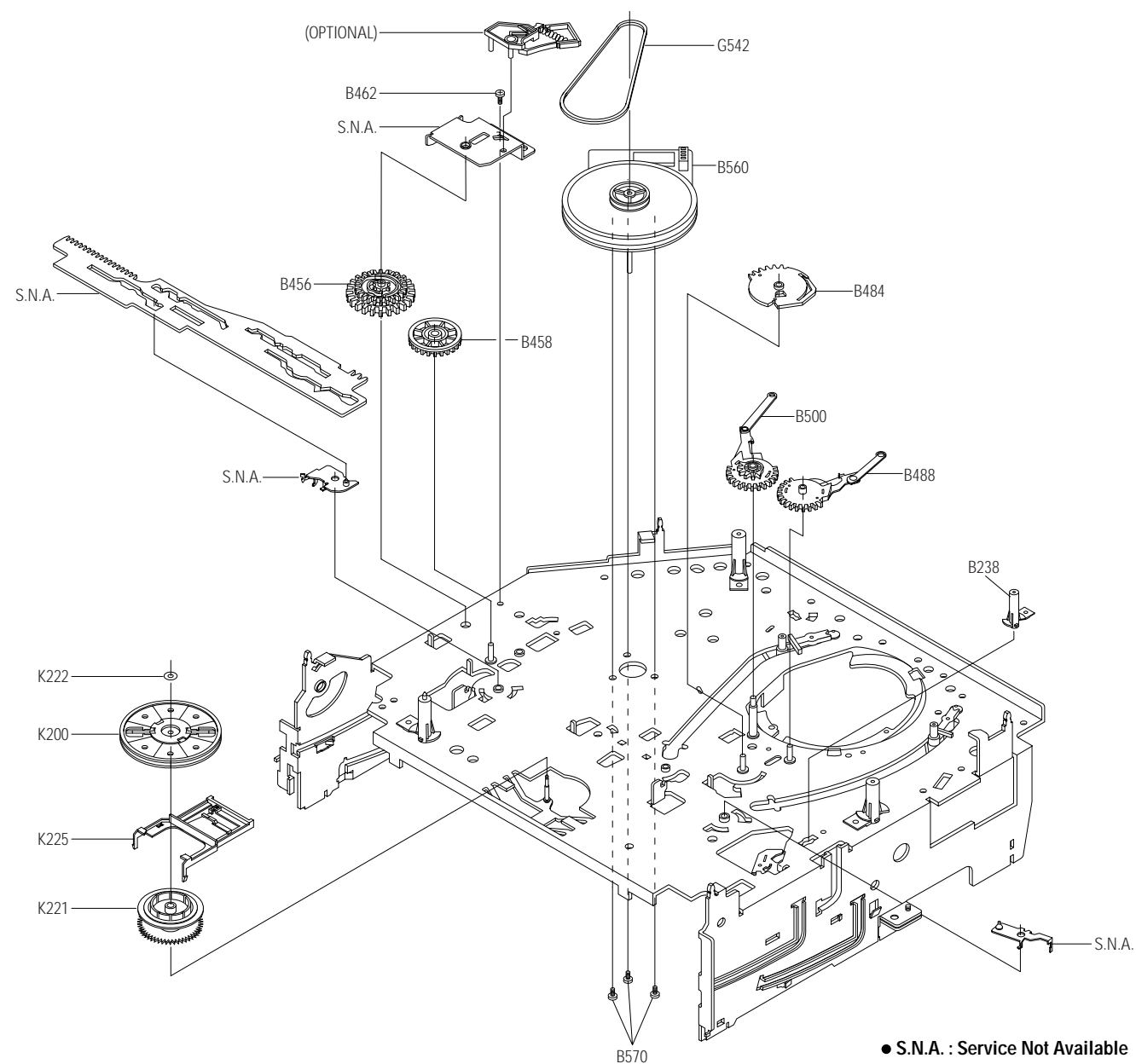

Loc. No	Part No	Description and Specification	Remark
B238	AC61-50660A	SLEEVE-TENSION-,POM M90-44,-,-,ID3,-,-,	
B456	AC66-20576A	GEAR-JOINT 1-,POM SW-01,M1.0,Z22,-,PCD2	
B458	AC66-20574A	GEAR-JOINT 2-,POM SW-01,M1.0,Z14,-,PCD1	
B462	AC60-10517A	SCREW-TAP TITE-,PH,+,-,M2.6,L5,ZPC,-,YE	
B484	AC66-20580A	GEAR-LOADING DRIVE-,POM SW-01,M1.0,Z32,	
B488	AC66-30543A	LEVER-S LOAD ASSY-,-,-,-,X-9	
B500	AC66-30542A	LEVER-T LOAD ASSY-,-,-,-,X-9	
B560	AC31-12017A	MOTOR-CAPSTAN DMVCMC07C,-,X-9	
B570	AC60-10514A	SCREW-CAPSTAN-,PH,+,-,M2.6,L6,-	
G542	AC66-60051A	BELT-PULLEY-,5CM-70,2 * 2,-,71.3,-,X-9	
K200	AC61-21012A	HOLDER-CLUTCH ASSY-,-,-,-,X-9	
K221	AC66-20581A	GEAR-CENTER ASSY-,POM,M=0.5,-,HIGHT T.,	
K222	AC60-30306A	WASHER-SLIT-,-,ID2.1,OD5.0,TO.5,-,POLYS	
K225	AC66-30547A	LEVER-UP DOWN ASSY-,POM+SUS,-,-,-,X-9	

## 8. Electric Parts List

### 8-1 TB14C52S/XEC (TB20C5DT2S AND TB14C52S Dissimilar Parts)

Loc. No.	Code No.	Description ; Specification	Remark	Loc. No.	Code No.	Description ; Specification	Remark
		<b>ASSY-PCB,MAIN(OPT)</b> BUYER : SESA				<b>ASSY-CRT</b> CRT-COLOR ; LOCAL (SESA)	
*	AA94-00427A	ASSY-PCB,MAIN(OPT);TB14C52S/XEC,C15A,SPAIN,SESA			AA39-20518A	LEAD CONNECTOR-ASSY;-YFH806-06,-.6(4)P,350mm,1617	
C403	2306-000326	C-FILM,MPPF:4.7nF,5%,1.6KV,TP,28.5x16x9mm,				<b>ASSY-PCB,CRT</b>	
C404	2306-000195	C-FILM,MPPF:360nF,5%,400V,TP,26x19x11.5,20				AA95-20010X	ASSY-PCB,CRT;-C15A,14,EU,230V
D819	0404-001056	DIODE-SCHOTTKY;RK16,60V,1.5A,DO-204AC,TP		*			
L401	AA27-30001K	COIL-LINEARITY;-;230uH,DR1215,PI0.5,14.1x26,-			R501M	2002-001009	R-COMPOSITION:2.7Kohm,10%,1/2W,AA,TP,3.7X9.0
L404	AA27-40001M	COIL-HORIZ.WIDTH;-;180/480uH,SB-5S6202.6,PI0.8,			R502M	2002-001009	R-COMPOSITION:2.7Kohm,10%,1/2W,AA,TP,3.7X9.0
L803	AA27-20003U	COIL-DEGAUSSING;-;14,16.4ohm,75T,890mm,D			V999	3704-000103	SOCKET-CRT;10P,22.5,14.3,SN,ISMS01S/BK
R301	2004-000500	R-METAL:2.7Kohm,1%,1/8W,AA,TP,1.8x3.2m				<b>ASSY-SPEAKER</b>	
R304	2003-000652	R-METAL OXIDE(S);330ohm,5%,2W,AF,TP,4x12mm				3001-001015	SPEAKER:2.5W,16ohm,88dB,150Hz
R417	2008-001009	R-FUSIBLE:1ohm,5%,1W,AA,TP,4.7x12.7mm				AA39-20015D	LEAD-CONNECTOR,ASSY;-;67096-003,-.3(2)P,300,1007#2
R612	2008-001018	R-FUSIBLE(S);0.47ohm,10%,2W,AF,TP,3.9x10mm				<b>REMOCON</b>	
R613	2008-001018	R-FUSIBLE(S);0.47ohm,10%,2W,AF,TP,3.9x10mm				AA59-00006C	REMOCON;-;TM48,SSOM728EU,40,L/GRAY,SS,EX,-,-
R615	2001-000429	R-CARBON:1KOHM,5%,1/8W,AA,TP,1.8X3.2MM				<b>ASSY-ACCESSORY</b>	
T444	AA26-00004A	TRANS-FLYBACK;-;FSA38026S,14INCH,125V		A/R	AA42-10001V	ANT-ROD;-;3S,620mm,BRN,UL/CSA	
TU001	AA40-10006M	TUNER-F/S;TECC2949PG29A(S),PAL-B/G,TR,18		T/M	AA26-90001C	TRANS-MATCHING;-;300ohm/75ohm,PAL,40-890MHZ	
		<b>ASSY-M/DECK</b>			AA68-00128A	MANUAL-USERS ; LOCAL (SESA)	
*	AA94-00193Q	ASSY-M/DECK:M-422YK,2HD,-,-,C15A					
		<b>ASSY-FRAME</b>					
*	AA90-40008K	ASSY-FRAME:TS-DECK,14C5 SESA ONLY					

### 8-2 TB14C5DT2S/XET (TB20C5DT2S AND TB14C5DT2S Dissimilar Parts)

Loc. No.	Code No.	Description ; Specification	Remark	Loc. No.	Code No.	Description ; Specification	Remark
		<b>ASSY-PCB,MAIN(OPT)</b> BUYER : SEI / SESA				<b>ASSY-CRT</b> CRT-COLOR ; LOCAL (SESA)	
*	AA94-00625A	ASSY-PCB,MAIN(OPT);TB14C5DT2S/XET,C15A,ITALY,SEI			AA39-20518A	LEAD CONNECTOR-ASSY;-YFH806-06,-.6(4)P,350mm,1617	
C403	2306-000326	C-FILM,MPPF:4.7nF,5%,1.6KV,TP,28.5x16x9mm,				<b>ASSY-PCB,CRT</b>	
C404	2306-000195	C-FILM,MPPF:360nF,5%,400V,TP,26x19x11.5,20				AA95-20010X	ASSY-PCB,CRT;-C15A,14,EU,230V
L401	AA27-30001K	COIL-LINEARITY;-;230uH,DR1215,PI0.5,14.1x26,-		*			
L404	AA27-40001M	COIL-HORIZ.WIDTH;-;180/480uH,SB-5S6202.6,PI0.8,			R501M	2002-001009	R-COMPOSITION:2.7Kohm,10%,1/2W,AA,TP,3.7X9.0
L803	AA27-20003U	COIL-DEGAUSSING;-;14,16.4ohm,75T,890mm,D			R502M	2002-001009	R-COMPOSITION:2.7Kohm,10%,1/2W,AA,TP,3.7X9.0
R301	2004-000500	R-METAL:2.7Kohm,1%,1/8W,AA,TP,1.8x3.2m			V999	3704-000103	SOCKET-CRT;10P,22.5,14.3,SN,ISMS01S/BK
R304	2003-000652	R-METAL OXIDE(S);330ohm,5%,2W,AF,TP,4x12mm				<b>ASSY-SPEAKER</b>	
R417	2008-001009	R-FUSIBLE:1ohm,5%,1W,AA,TP,4.7x12.7mm				3001-001015	SPEAKER:2.5W,16ohm,88dB,150Hz
R612	2008-001018	R-FUSIBLE(S);0.47ohm,10%,2W,AF,TP,3.9x10mm				AA39-20015D	LEAD-CONNECTOR,ASSY;-;67096-003,-.3(2)P,300,1007#2
R613	2008-001018	R-FUSIBLE(S);0.47ohm,10%,2W,AF,TP,3.9x10mm				<b>ASSY-ACCESSORY</b>	
R615	2001-000429	R-CARBON:1KOHM,5%,1/8W,AA,TP,1.8X3.2MM		A/R	AA42-10001V	ANT-ROD;-;3S,620mm,BRN,UL/CSA	
T444	AA26-00004A	TRANS-FLYBACK;-;FSA38026S,14INCH,125V		T/M	AA26-90001C	TRANS-MATCHING;-;300ohm/75ohm,PAL,40-890MHZ	
		<b>ASSY-M/DECK</b>			AA68-00127A	MANUAL-USERS ; LOCAL (SESA)	
*	AA94-00193Q	ASSY-M/DECK:M-422YK,2HD,-,-,C15A					
		<b>ASSY-FRAME</b>					
*	AA90-40008K	ASSY-FRAME:TS-DECK,14C5 SESA ONLY					



## 8-4 TB14C5T2S/XEC (TB20C5DT2S AND TB14C5T2S Dissimilar Parts)

Loc. No.	Code No.	Description ; Specification	Remark	Loc. No.	Code No.	Description ; Specification	Remark
<b>ASSY-PCB,MAIN(OPT)</b>				<b>ASSY-CRT</b>			
BUYER : SESA				CRT-COLOR ; LOCAL (SESA)			
*	AA94-00784A	ASSY-PCB,MAIN(OPT);TB14C5T2S/XEC,C15A,SPAIN,SESA	△		AA39-20518A	LEAD CONNECTOR-ASSY-;YFH806-06,-,6(4)P,350mm,1617	
C403	2306-000326	C-FILM,MPPF;4.7nF,5%,1.6KV,TP,28.5x16x9mm,			<b>ASSY-PCB,CRT</b>		
C404	2306-000195	C-FILM,MPPF;360nF,5%,400V,TP,26x19x11.5,20			AA95-20010X	ASSY-PCB,CRT-;C15A,14,EU,230V	
D819	0404-001056	DIODE-SCHOTTKY;RK16,60V,1.5A,DO-204AC,TP		*			
L401	AA27-30001K	COIL-LINEARITY;-;230uH,DR1215,PI0.5,14.1x26,-			R501M	2002-001009	R-COMPOSITION;2.7Kohm,10%,1/2W,AA,TP,3.7X9.0
L404	AA27-40001M	COIL-HORIZ.WIDTH;-;180/480uH,SB-5S6202.6,PI0.8,			R502M	2002-001009	R-COMPOSITION;2.7Kohm,10%,1/2W,AA,TP,3.7X9.0
L803	AA27-20003U	COIL-DEGAUSSING;-;14,16.4ohm,75T,890mm,D		△	V999	3704-000103	SOCKET-CRT;10P,22.5,14.3,SN,ISMS01S/BK
R301	2004-000500	R-METAL;2.7Kohm,1%,1/8W,AA,TP,1.8x3.2m			<b>ASSY-SPEAKER</b>		
R304	2003-000652	R-METAL OXIDE(S);330ohm,5%,2W,AF,TP,4x12mm			3001-001015	SPEAKER;2.5W,16ohm,88dB,150Hz	
R417	2008-001009	R-FUSIBLE;1ohm,5%,1W,AA,TP,4.7x12.7mm			AA39-20015D	LEAD-CONNECTOR,ASSY-;67096-003,-,3(2)P,300,1007#2	
R612	2008-001018	R-FUSIBLE(S);0.47ohm,10%,2W,AF,TP,3.9x10mm			<b>ASSY-ACCESSORY</b>		
R613	2008-001018	R-FUSIBLE(S);0.47ohm,10%,2W,AF,TP,3.9x10mm			AA42-10001V	ANT-ROD;-;3S,620mm,BRN,U/L/CSA	
R615	2001-000429	R-CARBON;1KOHM,5%,1/8W,AA,TP,1.8X3.2MM			AA26-90001C	TRANS-MATCHING;-;300ohm/75ohm,PAL,40-890MHZ	
△ T444	AA26-00004A	TRANS-FLYBACK;-;FSA38026S,14INCH,125V		A/R			
△ TU001	AA40-10006M	TUNER-F/S;TECC2949PG29A(S),PAL-B/G,TR,18		T/M			
<b>ASSY-M/DECK</b>							
*	AA94-00193Q	ASSY-M/DECK;M-422YK,2HD,-,C15A					
<b>ASSY-FRAME</b>							
*	AA90-40008K	ASSY-FRAME;TS-DECK,14C5 SESA ONLY					
	AA64-00024N	DOOR-HOUSING;-;TVCR 14,20,BK708P PAL TTX (0) ,ABS,HB					



## 8-5 TB20C52S/XET (TB20C5DT2S AND TB20C52S Dissimilar Parts)

Loc. No.	Code No.	Description ; Specification	Remark	Loc. No.	Code No.	Description ; Specification	Remark
<b>ASSY-PCB,MAIN(OPT)</b>							
BUYER : SEI / SESA							
*	AA94-00597A	ASSY-PCB,MAIN(OPT);TB20C52S/XET,C15A,ITALY,SEI					
D819	0404-001056	DIODE-SCHOTTKY;RK16,60V,1.5A,DO-204AC,TP					
△ TU001	AA40-10006M	TUNER-F/S;TECC2949PG29A(S),PAL-B/G,TR,18					
<b>ASSY-CABINET;20C5,TB20C52S/XET</b>							
	AA64-00024M	DOOR-HOUSING;-;TVCR 14,20,BK708P PAL TTX(X) EL,ABS					
<b>REMOCON</b>							
*	AA59-00006C	REMOCON;-;TM48,SSOM728EU,40,L/GRAY,SS,EX,-,-					
<b>ASSY-ACCESSORY</b>							
	AA68-00127A	MANUAL-USERS ; LOCAL (SESA)					

## 8-6 TB20C5DF2S/XET (TB20C5DT2S AND TB20C5DF2S Dissimilar Parts)

Loc. No.	Code No.	Description ; Specification	Remark	Loc. No.	Code No.	Description ; Specification	Remark
<b>ASSY-PCB,MAIN(OPT)</b>				<b>REMOCON</b>			
BUYER : SEI / SESA				AA59-00006AREMOCON;-;TM48,L/GRAY,SS,SSOM728EU,45,EX,-,-			
*	AA94-00518A	ASSY-PCB,MAIN(OPT);TB20C5DF2S/XET,C15A,ITALY,SEI		*	AA59-00006A	REMOCON;-;TM48,L/GRAY,SS,SSOM728EU,45,EX,-,-	
 IC902	1103-001106	IC-EEPROM;24C080,1028x8BIT,DIP,8P;300MIL		<b>ASSY-ACCESSORY</b>			
<b>ASSY-CABINET;20C5,TB20C5DF2S/XET</b>				AA68-00127A MANUAL-USERS ; LOCAL (SESA)			
AA64-00024S DOOR-HOUSING;-;TVCR (14,20),BK708P EL S/V TTX,2T,HIPS							

## 8-7 TB20C5DF2S/XEG (TB20C5DT2S AND TB20C5DF2S Dissimilar Parts)

Loc. No.	Code No.	Description ; Specification	Remark	Loc. No.	Code No.	Description ; Specification	Remark
<b>ASSY-PCB,MAIN(OPT)</b>				<b>REMOCON</b>			
BUYER : SEG / SESA				AA59-00006AREMOCON;-;TM48,L/GRAY,SS,SSOM728EU,45,EX,-,-			
*	AA94-00627A	ASSY-PCB,MAIN(OPT);TB20C5DF2S/XEG,C15A,GERMANY		<b>ASSY-ACCESSORY</b>			
C258	2202-000127	C-CERAMIC,MLC-AXIAL:10nF,+80-20%,25V,Y5V,TP,-,7.5		AA68-00124A MANUAL-USERS ; LOCAL (SESA)			
CP01	2201-000673	C-CERAMIC,DISC:820pF,10%,50V,Y5P,TP,5x3,5					
CP02	2202-000791	C-CERAMIC,MLC-AXIAL:150pF,10%,50V,Y5P,TP,3.5x19,-					
CP03	2305-000355	C-FILM,MPEF:330nF,5%,63V,TP,-,5mm					
CP04	2301-000224	C-FILM,PEF:22nF,5%,50V,TP,7.4x3.9x13mm,5m					
CP05	2301-000247	C-FILM,PEF:33nF,5%,50V,TP,8.1x4.5x13mm,5m					
CP06	2401-003102	C-AL:100uF,20%,10V,GP,TP,5x11,5					
DZP01	0403-000296	DIODE-ZENER:MTZ5.6B,5.6V,5.45-5.73V,500mW,					
 IC902	1103-001106	IC-EEPROM;24C080,1028x8BIT,DIP,8P;300MIL					
 ICP01	1204-001287	IC-DECODER;SDA5650,DIP,14P,-,PLASTIC,6V,3					
LP01	2701-000114	INDUCTOR-AXIAL:10uH,10%,2.5x3.4mm					
LP02	2701-000114	INDUCTOR-AXIAL:10uH,10%,2.5x3.4mm					
LP03	2701-000114	INDUCTOR-AXIAL:10uH,10%,2.5x3.4mm					
RP01	2001-000281	R-CARBON:100OHM,5%,1/8W,AA,TP,1.8X3.2MM					
RP02	2001-000281	R-CARBON:100OHM,5%,1/8W,AA,TP,1.8X3.2MM					
RP03	2001-000273	R-CARBON:100KOHM,5%,1/8W,AA,TP,1.8X3.2MM					
RP04	2001-000449	R-CARBON:2.2KOHM,5%,1/8W,AA,TP,1.8X3.2MM					
RP05	2001-000435	R-CARBON:1MOHM,5%,1/8W,AA,TP,1.8X3.2MM					
RP06	2001-000890	R-CARBON:6.8KOHM,5%,1/8W,AA,TP,1.8X3.2MM					
RP07	2001-000225	R-CARBON:1.2MOHM,5%,1/8W,AA,TP,1.8X3.2MM					
RP09	2001-000225	R-CARBON:1.2MOHM,5%,1/8W,AA,TP,1.8X3.2MM					
RP10	2001-000890	R-CARBON:6.8KOHM,5%,1/8W,AA,TP,1.8X3.2MM					

## 8-8 TB21B5DF2S/XEC (TB20C5DT2S AND TB21B5DF2S Dissimilar Parts)

Loc. No.	Code No.	Description ; Specification	Remark	Loc. No.	Code No.	Description ; Specification	Remark
<b>ASSY-PCB,MAIN(OPT)</b>							
BUYER : SESA							
*	AA94-00511A	ASSY-PCB,MAIN(OPT);TB21B5DF2S/XEC,C15A,SPAIN,SECA		QM605	0504-000118	TR-DIGITAL;KSR1003,NPN,300MW,22K/22K,TO-92,TP	
C403	2306-000253	C-FILM,MPPF;7.2nf,5%,1.6KV,TP,28.5x18.5x12		REM601	AA59-60003V	MODULE-REMOCON;DP,SRV-18,38KHz,940nm,MESH,V,S	
CN602	3711-002643	CONNECTOR-HEADER;BOX,4P,1R,2.5mm,STRAIGHT,SN		RM631	2001-001077	R-CARBON(S);150OHM,5%,1/2W,AA,TP,2.4X6.4MM	
IC902	1103-001106	IC-EEPROM;24C080,1028x8BIT,DIP,8P,300MIL		RM632	2001-001077	R-CARBON(S);150OHM,5%,1/2W,AA,TP,2.4X6.4MM	
L404	AA27-40001N	COIL-HORIZ.WIDTH:-,90/260uH,SB-5S620,PIO.8,-		RM633	2001-001077	R-CARBON(S);150OHM,5%,1/2W,AA,TP,2.4X6.4MM	
L803	AA27-20003Z	COIL-DEGAUSSING:-,21,13.5ohm,25T,L2380,E		RM637	2001-000290	R-CARBON;10KOHM,5%,1/8W,AA,TP,1.8X3.2MM	
<b>ASSY-M/DECK</b>							
*	AA94-80005L	ASSY-M/DECK;M-420YK/XEG-S,2HD,PAL/NT OB ON		SWM601	3404-000244	SWITCH-TACT;15V,20mA,90-170gf,7.5x7mm,SPST	
<b>ASSY-PCB,M/DECK</b>							
*	AA95-00091K	ASSY-PCB,M/DECK;-,-,C15A,2HD,PAL,-,NTPB		SWM602	3404-000244	SWITCH-TACT;15V,20mA,90-170gf,7.5x7mm,SPST	
CM631	2202-002037	C-CERAMIC,MLC-AXIAL;100nF,80-20%,50V,Y5V,TP,2.2x3.		SWM603	3404-000244	SWITCH-TACT;15V,20mA,90-170gf,7.5x7mm,SPST	
CM632	2401-002009	C-AL;100uF,20%,16V,GP,TP,6.3x7.5		SWM604	3404-000244	SWITCH-TACT;15V,20mA,90-170gf,7.5x7mm,SPST	
DM607	0401-000005	DIODE-SWITCHING;1N4148,75V,200MA,DO-35,TP		SWM605	3404-000244	SWITCH-TACT;15V,20mA,90-170gf,7.5x7mm,SPST	
DM608	0401-000005	DIODE-SWITCHING;1N4148,75V,200MA,DO-35,TP		SWM606	3404-000244	SWITCH-TACT;15V,20mA,90-170gf,7.5x7mm,SPST	
DM609	0401-000005	DIODE-SWITCHING;1N4148,75V,200MA,DO-35,TP		SWM607	3404-000244	SWITCH-TACT;15V,20mA,90-170gf,7.5x7mm,SPST	
LDM602	AA91-60317A	ASSY-GUIDE,LED;- ,ABS,VO,BLK,RED LED 03,TS-DEC		SWM608	3404-000244	SWITCH-TACT;15V,20mA,90-170gf,7.5x7mm,SPST	
QM603	0504-000118	TR-DIGITAL;KSR1003,NPN,300MW,22K/22K,TO-92,TP		SWM609	3404-000244	SWITCH-TACT;15V,20mA,90-170gf,7.5x7mm,SPST	
QM604	0504-000118	TR-DIGITAL;KSR1003,NPN,300MW,22K/22K,TO-92,TP		ZDM601	0403-000654	DIODE-ZENER;MTZ12B,12V,11.44-12.03V,500mW,	
				<b>REMOCON</b>			
				*	AA59-00006A	REMOCON;- ,TM48,L/GRAY,SS,SSOM728EU,45,EX,-,-	
				<b>ASSY-SPEAKER</b>			
				3001-001087 SPEAKER;5W,16OHM,90°±2DB,250+-50HZ			
				AA39-20505D LEAD CONNECTOR-ASSY;- ,YSH025-04,REC,4P,300.700,100			

## 8-9 TB20C5DT2S/XEC Parts List

Loc. No.	Code No.	Description ; Specification	Remark	Loc. No.	Code No.	Description ; Specification	Remark
<b>ASSY-PCB,MAIN(OPT)</b>							
BUYER : SESA							
*	AA94-00513A	ASSY-PCB,MAIN(OPT);TB20C5DT2S/XEC,C15A,SPAIN,SECA		C230	2401-001840	C-AL;100uF,20%,16V,GP,TP,6.3x11.5	
C101	2401-000030	C-AL;22uF,20%,25V,GP,TP,5x11.5		C231	2401-000480	C-AL;10uF,20%,50V,GP,TP,5x11.5	
C107	2202-000807	C-CERAMIC,MLC-AXIAL;22nf,+80-20%,25V,Y5V,TP,3.5x19		C232	2202-000849	C-CERAMIC,MLC-AXIAL;18pf,5%,50V,CH,TP,3.5x1.9,-	
C108	2401-000962	C-AL;22uF,20%,50V,GP,TP,5x11.5		C233	2202-000243	C-CERAMIC,MLC-AXIAL;33pf,5%,50V,SL,TP,3.5x19,-	
C109	2202-002037	C-CERAMIC,MLC-AXIAL;100nF,80-20%,50V,Y5V,TP,2.2x3.		C234	2301-000445	C-FILM,PEF;4.7nf,5%,50V,TP,5.5x7x3mm,5mm	
C112	2305-000196	C-FILM,MPEF;150nf,5%,63V,TP,-,5mm		C236	2301-000232	C-FILM,PEF;3.3nf,5%,50V,TP,8.1x4.5x13mm,5	
C113	2202-000127	C-CERAMIC,MLC-AXIAL;10nf,+80-20%,25V,Y5V,TP,-,7.5		C237	2305-000289	C-FILM,MPEF;220nf,5%,63V,TP,-,5mm	
C201	2401-002619	C-AL;47uF,20%,25V,GP,TP,5x11.5		C238	2301-000383	C-FILM,PEF;10nf,5%,50V,TP,6x7x3.2mm,5mm	
C202	2305-000412	C-FILM,MPEF;470nf,5%,63V,TP,-,5mm		C239	2401-000603	C-AL;1uF,20%,50V,GP,TP,5x11.5	
C204	2301-000224	C-FILM,PEF;22nf,5%,50V,TP,7.4x3.9x13mm,5m		C249	2401-000480	C-AL;10uF,20%,50V,GP,TP,5x11.5	
C205	2401-000660	C-AL;2.2uF,20%,50V,GP,TP,5x11.5		C250	2306-000122	C-FILM,MPPF;100nf,5%,50V,TP,7.3x4.0x5.0mm,	
C206	2306-000122	C-FILM,MPPF;100nf,5%,50V,TP,7.3x4.0x5.0mm,		C251	2306-000122	C-FILM,MPPF;100nf,5%,50V,TP,7.3x4.0x5.0mm,	
C207	2401-001840	C-AL;100uF,20%,16V,GP,TP,6.3x11.5		C253	2202-000210	C-CERAMIC,MLC-AXIAL;270pf,10%,50V,Y5P,TP,1.9x3.5,7	
C208	2305-000411	C-FILM,MPEF;470nf,5%,50V,TP,7.3x4.8x5.5mm,		C254	2202-000127	C-CERAMIC,MLC-AXIAL;10nf,+80-20%,25V,Y5V,TP,-,7.5	
C209	2305-000289	C-FILM,MPEF;220nf,5%,63V,TP,-,5mm		C255	2401-002619	C-AL;47uF,20%,25V,GP,TP,5x11.5	
C210	2305-000411	C-FILM,MPEF;470nf,5%,50V,TP,7.3x4.8x5.5mm,		C257	2202-000791	C-CERAMIC,MLC-AXIAL;150pf,10%,50V,Y5P,TP,3.5x19,-	
C211	2301-000232	C-FILM,PEF;3.3nf,5%,50V,TP,8.1x4.5x13mm,5		C259	2202-000243	C-CERAMIC,MLC-AXIAL;33pf,5%,50V,SL,TP,3.5x19,-	
C212	2306-000122	C-FILM,MPPF;100nf,5%,50V,TP,7.3x4.0x5.0mm,		C261	2301-000192	C-FILM,PEF;1nf,5%,50V,TP,5.3x10mm,5mm	
C213	2306-000122	C-FILM,MPPF;100nf,5%,50V,TP,7.3x4.0x5.0mm,		C262	2202-000210	C-CERAMIC,MLC-AXIAL;270pf,10%,50V,Y5P,TP,1.9x3.5,7	
C214	2306-000122	C-FILM,MPPF;100nf,5%,50V,TP,7.3x4.0x5.0mm,		C263	2202-000143	C-CERAMIC,MLC-AXIAL;10pf,5%,50V,NPO,TP,1.9x3.5,-	
C215	2401-000480	C-AL;10uF,20%,50V,GP,TP,5x11.5		C265	2401-002144	C-AL;47uF,20%,16V,GP,TP,5x11.5	
C219	2201-000273	C-CERAMIC,DISC;18pf,5%,50V,CH,TP,5x3mm,5		C301	2202-000253	C-CERAMIC,MLC-AXIAL;4.7nf,20%,16V,Y5R,TP,1.9x3.5,7	
C221	2306-000122	C-FILM,MPPF;100nf,5%,50V,TP,7.3x4.0x5.0mm,		C302	2401-003140	C-AL;47uF,20%,50V,WT/NP,TP,10x20,5	
C222	2401-001840	C-AL;100uF,20%,16V,GP,TP,6.3x11.5		C303	2305-000149	C-FILM,MPEF;100nf,5%,100V,TP,12x12.5x6.5,5	
C225	2401-000603	C-AL;1uF,20%,50V,GP,TP,5x11.5		C304	2305-000285	C-FILM,MPEF;220nf,5%,100V,TP,10.5X5.5X15MM,5	
C226	2401-000603	C-AL;1uF,20%,50V,GP,TP,5x11.5		C305	2202-000253	C-CERAMIC,MLC-AXIAL;4.7nf,20%,16V,Y5R,TP,1.9x3.5,7	
C227	2202-000796	C-CERAMIC,MLC-AXIAL;1nf,10%,50V,Y5P,TP,3.5x1.9MM,-		C306	2401-002288	C-AL;470uF,20%,25V,WT,TP,10x20,5	
C228	2309-000138	C-FILM,PE-PF;100nf,5%,50V,TP,20x16x8.5,7.5m		C307	2305-000285	C-FILM,MPEF;220nf,5%,100V,TP,10.5X5.5X15MM,5	
				C401	2301-000383	C-FILM,PEF;10nf,5%,50V,TP,6x7x3.2mm,5mm	
				C402	2201-000406	C-CERAMIC,DISC;270pf,10%,2KV,Y5P,TP,8x6.7,5	
				C403	2306-000267	C-FILM,MPPF;8.2nf,5%,1.6KV,TP,28.5x18.5x12	
				C404	2306-000204	C-FILM,MPPF;430nf,5%,400V,TP,26x20.5x12.5,	

Electric Parts List

Loc. No.	Code No.	Description ; Specification	Remark	Loc. No.	Code No.	Description ; Specification	Remark
C405	2305-000154	C-FILM,MPEF;100nf,5%,400V,TP,21.5x6.5x11.5		C904	2201-000247	C-CERAMIC,DISC;15pf,5%,50V,CH,TP,5x3,5	
C406	2201-000556	C-CERAMIC,DISC;470pf,10%,500V,Y5P,TP,7x4,5		C905	2301-000227	C-FILM,PEF;27nf,5%,50V,TP,7x3.5x6.5mm,5mm	
C407	2401-002288	C-AL:470uf,20%,25V,WT,TP,10x20,5		C906	2401-000030	C-AL:22uf,20%,25V,GP,TP,5x11,5	
C408	2201-000556	C-CERAMIC,DISC;470pf,10%,500V,Y5P,TP,7x4,5		C907	2201-000423	C-CERAMIC,DISC;27pf,5%,50V,NPO,TP,5x3,2,5	
C409	2401-001661	C-AL:68uf,20%,100V,GP,TP,10x16,5		C908	2201-000423	C-CERAMIC,DISC;27pf,5%,50V,NPO,TP,5x3,2,5	
C411	2201-000556	C-CERAMIC,DISC;470pf,10%,500V,Y5P,TP,7x4,5		C909	2202-000121	C-CERAMIC,MLC-AXIAL;100pf,10%,50V,Y5P,TP,1.9x3.5,-	
C412	2401-000927	C-AL:22uf,20%,250V,GP,TP,13x20,5		C910	2202-000121	C-CERAMIC,MLC-AXIAL;100pf,10%,50V,Y5P,TP,1.9x3.5,-	
C413	2401-003028	C-AL:100uf,20%,25V,WT,TP,6.3x11,5		C911	2202-000121	C-CERAMIC,MLC-AXIAL;100pf,10%,50V,Y5P,TP,1.9x3.5,-	
C414	2201-000984	C-CERAMIC,DISC;680pf,10%,2KV,Y5P,TP,11x6,7.5mm		C915	2306-000122	C-FILM,MPPF;100nf,5%,50V,TP,7.3x4.0x5.0mm,	
C415	2305-000382	C-FILM,MPEF;4.7nf,5%,400V,TP,-,5mm		C916	2401-002594	C-AL:220uf,20%,16V,GP,TP,8x11,5,5	
C601	2401-001998	C-AL:1000uf,20%,25V,GP,TP,10x20,5mm		C920	2301-000192	C-FILM,PEF;1nf,5%,50V,TP,5.3x10mm,5mm	
C602	2306-000122	C-FILM,MPPF;100nf,5%,50V,TP,7.3x4.0x5.0mm,		CB03	2202-000127	C-CERAMIC,MLC-AXIAL;10nf,+80-20%,25V,Y5V,TP,-,7.5	
C604	2401-000480	C-AL:10uf,20%,50V,GP,TP,5x11,5		CK01	2202-000127	C-CERAMIC,MLC-AXIAL;10nf,+80-20%,25V,Y5V,TP,-,7.5	
C605	2301-000445	C-FILM,PEF;4.7nf,5%,50V,TP,5.5x7x3mm,5mm		CK02	2202-000127	C-CERAMIC,MLC-AXIAL;10nf,+80-20%,25V,Y5V,TP,-,7.5	
C606	2401-002619	C-AL:47uf,20%,25V,GP,TP,5x11,5		CL01	2202-000127	C-CERAMIC,MLC-AXIAL;10nf,+80-20%,25V,Y5V,TP,-,7.5	
C607	2401-000914	C-AL:220uf,20%,16V,GP,TP,5x11,5		CN101	3711-002641	CONNECTOR-HEADER;BOX,10P,1R,2.54mm,STRAIGHT,SN	
C608	2401-001998	C-AL:100uf,20%,25V,GP,TP,10x20,5mm		CN102	3711-003641	CONNECTOR-HEADER;BOX,12P,1R,2.5mm,STRAIGHT,SN	
C610	2401-001397	C-AL:470uf,20%,25V,GP,TP,10x16,5		CN501C	3711-002647	CONNECTOR-HEADER;BOX,8P,1R,2.5mm,STRAIGHT,SN	
C701	2401-000471	C-AL:10uf,20%,50V,BP,TP,5x11,5mm		CN601	3711-002642	CONNECTOR-HEADER;BOX,3P,1R,2.5mm,STRAIGHT,SN	
C702	2401-001989	C-AL:4.7uf,20%,50V,BP,TP,5x11,5		CN701	3711-002646	CONNECTOR-HEADER;BOX,7P,1R,2.5mm,STRAIGHT,SN	
C703	2202-000121	C-CERAMIC,MLC-AXIAL;100pf,10%,50V,Y5P,TP,1.9x3.5,-		CN702	3711-002644	CONNECTOR-HEADER;BOX,5P,1R,2.5mm,STRAIGHT,SN	
C704	2202-000121	C-CERAMIC,MLC-AXIAL;100pf,10%,50V,Y5P,TP,1.9x3.5,-		CN901	3711-002644	CONNECTOR-HEADER;BOX,5P,1R,2.5mm,STRAIGHT,SN	
C705	2401-001363	C-AL:470uf,20%,16V,GP,TP,10x12,5,5		D102	0401-000005	DIODE-SWITCHING;1N4148,75V,200MA,DO-35,TP	
C708	2401-000480	C-AL:10uf,20%,50V,GP,TP,5x11,5		D205	0401-000005	DIODE-SWITCHING;1N4148,75V,200MA,DO-35,TP	
C710	2401-000471	C-AL:10uf,20%,50V,BP,TP,5x11,5mm		D209	0401-000005	DIODE-SWITCHING;1N4148,75V,200MA,DO-35,TP	
C711	2401-000480	C-AL:10uf,20%,50V,GP,TP,5x11,5		D210	0401-000005	DIODE-SWITCHING;1N4148,75V,200MA,DO-35,TP	
C715	2401-002619	C-AL:47uf,20%,25V,GP,TP,5x11,5		D401	0402-000132	DIODE-RECTIFIER;1N4004,400V,1A,DO-41,TP	
C717	2401-000471	C-AL:10uf,20%,50V,BP,TP,5x11,5mm		D402	0402-000132	DIODE-RECTIFIER;1N4004,400V,1A,DO-41,TP	
C724	2401-001989	C-AL:4.7uf,20%,50V,BP,TP,5x11,5		D403	0402-000540	DIODE-RECTIFIER;RU20A,600V,1.5A,-,TP	
C725	2401-000480	C-AL:10uf,20%,50V,GP,TP,5x11,5		D404	0402-000546	DIODE-RECTIFIER;TVR10G,400V,1.0A,DO-41,TP	
C726	2401-002619	C-AL:47uf,20%,25V,GP,TP,5x11,5		D405	0402-000546	DIODE-RECTIFIER;TVR10G,400V,1.0A,DO-41,TP	
C727	2202-000231	C-CERAMIC,MLC-AXIAL;330pf,10%,50V,Y5P,TP,3.5x19,-		D407	0402-000132	DIODE-RECTIFIER;1N4004,400V,1A,DO-41,TP	
C728	2202-000231	C-CERAMIC,MLC-AXIAL;330pf,10%,50V,Y5P,TP,3.5x19,-		D601	0402-000132	DIODE-RECTIFIER;1N4004,400V,1A,DO-41,TP	
C729	2401-000480	C-AL:10uf,20%,50V,GP,TP,5x11,5		D602	0402-000132	DIODE-RECTIFIER;1N4004,400V,1A,DO-41,TP	
C730	2401-000493	C-AL:10uf,20%,50V,LZ,TP,5x11mm,5mm		D603	0401-000005	DIODE-SWITCHING;1N4148,75V,200MA,DO-35,TP	
C800A	2201-000987	C-CERAMIC,DISC;2.2nf,20%,400V,Y5U,TP,15x8,10		D604	0402-000132	DIODE-RECTIFIER;1N4004,400V,1A,DO-41,TP	
C800B	2201-000963	C-CERAMIC,DISC;1nf,20%,400V,Y5U,TP,11x8mm,10mm		D801	0402-000213	DIODE-RECTIFIER;ERB12-06,600V,1.0A,DO-41,TP	
C801	2306-000318	C-FILM,MPPF;220nf,20%,250V,TP,-,22.5mm		D802	0402-000213	DIODE-RECTIFIER;ERB12-06,600V,1.0A,DO-41,TP	
C802	2306-000318	C-FILM,MPPF;220nf,20%,250V,TP,-,22.5mm		D803	0402-000213	DIODE-RECTIFIER;ERB12-06,600V,1.0A,DO-41,TP	
C804	2401-002619	C-AL:47uf,20%,25V,GP,TP,5x11,5		D804	0402-000213	DIODE-RECTIFIER;ERB12-06,600V,1.0A,DO-41,TP	
C805	2401-002300	C-AL:47uf,20%,50V,GP,TP,6.3x11,5		D805	0402-001105	DIODE-RECTIFIER;ERB43-04SV1,400V,1.0A,-,TP	
C806	2301-000310	C-FILM,PEF;68nf,5%,50V,TP,8.0X8.5X4.0X5,5		D806	0402-000132	DIODE-RECTIFIER;1N4004,400V,1A,DO-41,TP	
C807	2401-002241	C-AL:220uf,+30-10%,400V,GP,ST,30x40		D808	0402-001105	DIODE-RECTIFIER;ERB43-04SV1,400V,1.0A,-,TP	
C808	2303-000163	C-FILM,PPF;2.2nf,5%,800V,TP,15x13x8.5,7.5		D809	0402-001105	DIODE-RECTIFIER;ERB43-04SV1,400V,1.0A,-,TP	
C810	2301-000224	C-FILM,PEF;22nf,5%,50V,TP,7.4x3.9x13mm,5mm		D811	0402-000132	DIODE-RECTIFIER;1N4004,400V,1A,DO-41,TP	
C811	2301-000192	C-FILM,PEF;1nf,5%,50V,TP,5.3x10mm,5mm		D812	0402-000540	DIODE-RECTIFIER;RU20A,600V,1.5A,-,TP	
C812	2201-000374	C-CERAMIC,DISC;220pf,5%,50V,CH,TP,12.5x3,5		D817	0402-000132	DIODE-RECTIFIER;1N4004,400V,1A,DO-41,TP	
C813	2201-000991	C-CERAMIC,DISC;560pf,10%,2KV,Y5P,TP,13x7,7.5		D818	0402-000233	DIODE-RECTIFIER;FML-G125,200V,5A,-,-	
C815	2201-000991	C-CERAMIC,DISC;560pf,10%,2KV,Y5P,TP,13x7,7.5		D820	0404-001056	DIODE-SCHOTTKY;RK16,60V,1.5A,DO-204AC,TP	
C816	2201-000991	C-CERAMIC,DISC;560pf,10%,2KV,Y5P,TP,13x7,7.5		D821	0402-000546	DIODE-RECTIFIER;TVR10G,400V,1.0A,DO-41,TP	
C819	2401-000262	C-AL:100uf,20%,160V,HR,TP,16x25,7.5		D829	0401-000005	DIODE-SWITCHING;1N4148,75V,200MA,DO-35,TP	
C820	2401-000262	C-AL:100uf,20%,160V,HR,TP,16x25,7.5		D831	0401-000005	DIODE-SWITCHING;1N4148,75V,200MA,DO-35,TP	
C821	2401-002594	C-AL:220uf,20%,16V,GP,TP,8x11,5,5		D832	0401-000005	DIODE-SWITCHING;1N4148,75V,200MA,DO-35,TP	
C822	2401-002300	C-AL:47uf,20%,50V,GP,TP,6.3x11,5		D833	0401-000005	DIODE-SWITCHING;1N4148,75V,200MA,DO-35,TP	
C823	2401-001363	C-AL:470uf,20%,16V,GP,TP,10x12,5,5		D834	0401-000005	DIODE-SWITCHING;1N4148,75V,200MA,DO-35,TP	
C824	2401-001363	C-AL:470uf,20%,16V,GP,TP,10x12,5,5		D901	0401-000005	DIODE-SWITCHING;1N4148,75V,200MA,DO-35,TP	
C825	2401-000722	C-AL:220uf,20%,25V,WT,TP,16x25,7.5		D906	0401-000005	DIODE-SWITCHING;1N4148,75V,200MA,DO-35,TP	
C826	2401-000302	C-AL:100uf,20%,25V,GP,TP,6.3x11,5		D908	0401-000005	DIODE-SWITCHING;1N4148,75V,200MA,DO-35,TP	
C827	2306-000122	C-FILM,MPPF;100nf,5%,50V,TP,7.3x4.0x5.0mm,		D909	0401-000005	DIODE-SWITCHING;1N4148,75V,200MA,DO-35,TP	
C828	2401-001363	C-AL:470uf,20%,16V,GP,TP,10x12,5,5		D910	0401-000005	DIODE-SWITCHING;1N4148,75V,200MA,DO-35,TP	
C829	2401-002594	C-AL:220uf,20%,16V,GP,TP,8x11,5,5		D912	0401-000005	DIODE-SWITCHING;1N4148,75V,200MA,DO-35,TP	
C830	2401-002594	C-AL:220uf,20%,16V,GP,TP,8x11,5,5		D913	0401-000005	DIODE-SWITCHING;1N4148,75V,200MA,DO-35,TP	
C831	2401-001363	C-AL:470uf,20%,16V,GP,TP,10x12,5,5		D914	0401-000005	DIODE-SWITCHING;1N4148,75V,200MA,DO-35,TP	
C832	2306-000122	C-FILM,MPPF;100nf,5%,50V,TP,7.3x4.0x5.0mm,		D916	0401-000005	DIODE-SWITCHING;1N4148,75V,200MA,DO-35,TP	
C834	2306-000122	C-FILM,MPPF;100nf,5%,50V,TP,7.3x4.0x5.0mm,		D919	0401-000005	DIODE-SWITCHING;1N4148,75V,200MA,DO-35,TP	
C835	2401-002075	C-AL:4.7uf,20%,50V,GP,TP,5x11,5		D921	0401-000005	DIODE-SWITCHING;1N4148,75V,200MA,DO-35,TP	
C836	2401-002594	C-AL:220uf,20%,16V,GP,TP,8x11,5,5		DK01	0401-000005	DIODE-SWITCHING;1N4148,75V,200MA,DO-35,TP	
C837	2306-000122	C-FILM,MPPF;100nf,5%,50V,TP,7.3x4.0x5.0mm,		DK02	0401-000005	DIODE-SWITCHING;1N4148,75V,200MA,DO-35,TP	
C838	2401-003141	C-AL:2200uf,20%,25V,WT,TP,13x25,5mm		DZ201	0403-000551	DIODE-ZENER;MTZ3.9B,3.9V,3.89-4.16V,500mW	
C839	2401-000133	C-AL:1000uf,20%,16V,GP,TP,10x20,5		DZ222	0403-000560	DIODE-ZENER;MTZ6.8B,6.8V,6.49-6.83V,500mW	
C840	2306-000122	C-FILM,MPPF;100nf,5%,50V,TP,7.3x4.0x5.0mm,		DZ301	0403-000660	DIODE-ZENER;MTZ22A,22V,20.15-21.2V,500mW	
C844	2401-002594	C-AL:220uf,20%,16V,GP,TP,8x11,5,5		DZ302	0403-000700	DIODE-ZENER;TZP33A,33V,31-35V,1W,DO-41,TP	
C850	2401-001840	C-AL:100uf,20%,16V,GP,TP,6.3x11,5		DZ303	0403-001039	DIODE-ZENER;MA2560,56V,52-60V,1W,DO-41,TP	
C853	2401-001397	C-AL:470uf,20%,25V,GP,TP,10x16,5		DZ304	0403-000656	DIODE-ZENER;MTZ15C,15V,14.35-15.09V,500mW	
C901	2202-000796	C-CERAMIC,MLC-AXIAL;1nf,10%,50V,Y5P,TP,3.5X1.9MM,-		DZ601	0403-000656	DIODE-ZENER;MTZ15C,15V,14.35-15.09V,500mW	
C902	2201-000247	C-CERAMIC,DISC;15pf,5%,50V,CH,TP,5x3,5		DZ702	0403-000563	DIODE-ZENER;MTZ9.1B,9.1V,8.57-9.01V,500mW	
C903	2401-000027	C-AL:4.7uf,20%,50V,GP,TP,5x11,5		DZ704	0403-000563	DIODE-ZENER;MTZ9.1B,9.1V,8.57-9.01V,500mW	

Loc. No.	Code No.	Description ; Specification	Remark	Loc. No.	Code No.	Description ; Specification	Remark
DZ705	0403-000563	DIODE-ZENER:MTZ9.1B,9.1V,8.57-9.01V,500mW,		Q206	0501-000389	TR-SMALL SIGNAL:KSC815,NPN,400mW,TO-92,TP,120-	
DZ706	0403-000563	DIODE-ZENER:MTZ9.1B,9.1V,8.57-9.01V,500mW,		Q207	0501-000389	TR-SMALL SIGNAL:KSC815,NPN,400mW,TO-92,TP,120-	
DZ707	0403-000563	DIODE-ZENER:MTZ9.1B,9.1V,8.57-9.01V,500mW,		△ Q401	0502-001115	TR-POWER:KSC5386,NPN,50W,TO-3PF,ST-8-	
DZ801	1405-000152	VARISTOR:560V,2500A,14x8.5mm,TP		△ Q402	0501-000369	TR-SMALL SIGNAL:KSC2331-Y,NPN,1W,TO-92L-,120-	
DZ802	0403-000300	DIODE-ZENER:MTZ8.2B,8.2V,7.78-8.19V,500mW,		Q601	0504-000123	TR-DIGITAL:KSR1010,NPN,300mW,10K,TO-92,TP	
DZ803	0403-000700	DIODE-ZENER:TZP33A,33V,31-35V,1W,DO-41,TP		Q701	0501-000283	TR-SMALL SIGNAL:KSA539,PNP,400mW,TO-92,TP,120-	
DZ804	0403-000296	DIODE-ZENER:MTZ5.6B,5.6V,5.45-5.73V,500mW,		△ Q801	1203-001494	IC-PWM CONTROLLER:3S0680RF,T03PF-5L,5,210,PLASTI	
DZ805	0403-000705	DIODE-ZENER:TZP8.2B,8.2V,8.2-9.3V,1W,DO-41		△ Q802	0501-000369	TR-SMALL SIGNAL:KSC2331-Y,NPN,1W,TO-92L-,120-	
DZ806	1405-000152	VARISTOR:560V,2500A,14x8.5mm,TP		△ Q803	0501-000283	TR-SMALL SIGNAL:KSA539,PNP,400mW,TO-92,TP,120-	
DZ807	0403-000355	DIODE-ZENER:UZ5.1BSB,5.1V,4.97-5.18V,500mW		Q901	0501-000389	TR-SMALL SIGNAL:KSC815,NPN,400mW,TO-92,TP,120-	
DZ808	0403-000296	DIODE-ZENER:MTZ5.6B,5.6V,5.45-5.73V,500mW,		Q903	0501-000389	TR-SMALL SIGNAL:KSC815,NPN,400mW,TO-92,TP,120-	
DZ901	0403-000355	DIODE-ZENER:UZ5.1BSB,5.1V,4.97-5.18V,500mW		Q904	0501-000389	TR-SMALL SIGNAL:KSC815,NPN,400mW,TO-92,TP,120-	
DZ902	0403-000297	DIODE-ZENER:MTZ6.2B,6.2V,5.96-6.27V,500mW,		R101	2001-000613	R-CARBON:3.9KOHM,5%,1/8W,AA,TP,1.8X3.2MM	
DZ903	0403-000560	DIODE-ZENER:MTZ6.8B,6.8V,6.49-6.83V,500mW,		R102	2001-000660	R-CARBON:33KOHM,5%,1/8W,AA,TP,1.8X3.2MM	
DZ904	0403-000300	DIODE-ZENER:MTZ8.2B,8.2V,7.78-8.19V,500mW,		R107	2001-000281	R-CARBON:100OHM,5%,1/8W,AA,TP,1.8X3.2MM	
DZ905	0403-000296	DIODE-ZENER:MTZ5.6B,5.6V,5.45-5.73V,500mW,		R119	2001-000331	R-CARBON:120OHM,5%,1/8W,AA,TP,1.8X3.2MM	
△ F801	3601-000261	FUSE-FERRULE:250V,3.15A,TL,GLASS,5.2x20mm		R202	2001-000281	R-CARBON:100OHM,5%,1/8W,AA,TP,1.8X3.2MM	
△ F802	3601-001086	FUSE-FERRULE:125V,5A,FA,GLASS,2.4x7.5mm		R203	2001-000281	R-CARBON:100OHM,5%,1/8W,AA,TP,1.8X3.2MM	
△ F803	3601-001086	FUSE-FERRULE:125V,5A,FA,GLASS,2.4x7.5mm		R204	2001-000281	R-CARBON:100OHM,5%,1/8W,AA,TP,1.8X3.2MM	
F81	3602-000114	FUSE-HOLDER:-,30mohm		R205	2001-000005	R-CARBON:390OHM,5%,1/8W,AA,TP,1.8X3.2MM	
F82	3602-000114	FUSE-HOLDER:-,30mohm		R206	2001-000008	R-CARBON:15KOHM,5%,1/8W,AA,TP,1.8X3.2MM	
GT02A	AA39-20010B	LEAD-CONNECTOR,ASSY:-,YFH800-01,S,1P,500,1617#22		R207	2001-000281	R-CARBON:100OHM,5%,1/8W,AA,TP,1.8X3.2MM	
△ HC001	AA13-20004WIC-HYBRID:-,PAP103T,SIP,6P,PRE-AMP,TP		R208	2001-000281	R-CARBON:100OHM,5%,1/8W,AA,TP,1.8X3.2MM		
△ IC201	1204-001439	IC-VIDEO PROCESS:TDA8841,DIP,56P,-,PLASTIC,8.0V		R209	2001-000281	R-CARBON:100OHM,5%,1/8W,AA,TP,1.8X3.2MM	
△ IC301	1204-000441	IC-IF CIRCUIT:TDA8356,SIP,9P,-,PLASTIC,40V,-		R212	2001-000273	R-CARBON:100KOHM,5%,1/8W,AA,TP,1.8X3.2MM	
△ IC601	1201-001386	IC-POWER AMP:7267,DIP,16P,-,DUAL,32dB,PLAST		R213	2001-000016	R-CARBON(S):10OHM,5%,1/2W,AA,TP,2.4X6.4MM	
△ IC701	0801-000961	IC-CMOS LOGIC:4053,MULTIPLEXER,DIP,16P,300MIL		R215	2001-000008	R-CARBON:15KOHM,5%,1/8W,AA,TP,1.8X3.2MM	
△ IC702	0801-000213	IC-CMOS LOGIC:4052,MULTIPLEXER,DIP,16P,300MIL		R216	2001-000947	R-CARBON:7.5KOHM,5%,1/8W,AA,TP,1.8X3.2MM	
△ IC801	0604-001038	PHOTO-COUPLER:TR,130-260%,200mW,DIP,4,ST		R218	2004-001914	R-METAL:39Kohm,2%,1/8W,AA,TP,1.8x3.5mm	
△ IC802	1203-001127	IC-POSI.ADJUST REG.:431,TO-92,3P,4.58MIL,PLASTIC,2		R219	2001-000016	R-CARBON(S):10OHM,5%,1/2W,AA,TP,2.4X6.4MM	
△ IC804	1203-000284	IC-POSI.FIXED REG.:7806,TO-220,3P,-,PLASTIC,5.75/		R220	2001-000429	R-CARBON:1KOHM,5%,1/8W,AA,TP,1.8X3.2MM	
△ IC806	1203-001225	IC-POSI.FIXED REG.:78R09,TO-220,4P,-,PLASTIC,8.78		R221	2001-000429	R-CARBON:1KOHM,5%,1/8W,AA,TP,1.8X3.2MM	
△ IC807	1203-001225	IC-POSI.FIXED REG.:78R09,TO-220,4P,-,PLASTIC,8.78		R222	2001-000429	R-CARBON:1KOHM,5%,1/8W,AA,TP,1.8X3.2MM	
△ IC901	AA13-00013AIC-MCU:-,CXP85340A-329S,8BIT,ST,TF-502V,64P,750MIL		R223	2001-000429	R-CARBON:1KOHM,5%,1/8W,AA,TP,1.8X3.2MM		
△ IC902	1103-000156	IC-EEPROM:24C04,512x8BIT,DIP,8P,300MIL,1		R225	2001-000273	R-CARBON:100KOHM,5%,1/8W,AA,TP,1.8X3.2MM	
△ IC903	1202-000001	IC-VOLTAGE COMP.:7533,TO-92,3P,-,SINGLE,-,PLA		R226	2001-000429	R-CARBON:1KOHM,5%,1/8W,AA,TP,1.8X3.2MM	
IF/CAB	AA39-30007AIF-CABLE:-,T,100mm,1365#26		R227	2001-000429	R-CARBON:1KOHM,5%,1/8W,AA,TP,1.8X3.2MM		
J196	2701-000002	INDUCTOR-AXIAL:100uH,10%,4.2x9.8mm		R228	2001-000577	R-CARBON:2KOHM,5%,1/8W,AA,TP,1.8X3.2MM	
JS701	3722-000183	JACK-SCART:21P,4mm,SN,BLK,NO		R230	2001-000281	R-CARBON:100OHM,5%,1/8W,AA,TP,1.8X3.2MM	
L101	2701-000326	INDUCTOR-AXIAL:560nH,10%,2.3x3.4mm		R234	2001-000832	R-CARBON:510OHM,5%,1/8W,AA,TP,1.8X3.2MM	
L103	2701-000114	INDUCTOR-AXIAL:10uH,10%,2.5x3.4mm		R237	2001-000563	R-CARBON:27KOHM,5%,1/8W,AA,TP,1.8X3.2MM	
L104	2701-000114	INDUCTOR-AXIAL:10uH,10%,2.5x3.4mm		R243	2001-000429	R-CARBON:1KOHM,5%,1/8W,AA,TP,1.8X3.2MM	
L105	2701-000114	INDUCTOR-AXIAL:10uH,10%,2.5x3.4mm		R244	2001-000780	R-CARBON:470OHM,5%,1/8W,AA,TP,1.8X3.2MM	
L106	2701-000114	INDUCTOR-AXIAL:10uH,10%,2.5x3.4mm		R247	2001-000490	R-CARBON:200OHM,5%,1/8W,AA,TP,1.8X3.2MM	
L108	2701-000180	INDUCTOR-AXIAL:33uH,5%,2.5x3.4mm		R248	2001-000938	R-CARBON:680OHM,5%,1/8W,AA,TP,1.8X3.2MM	
L201	2701-000184	INDUCTOR-AXIAL:4.7uH,10%,2.5x3.4mm		R249	2001-000832	R-CARBON:510OHM,5%,1/8W,AA,TP,1.8X3.2MM	
L202	2701-000146	INDUCTOR-AXIAL:2.2uH,10%,2.5x3.4mm		R250	2001-000857	R-CARBON:560OHM,5%,1/8W,AA,TP,1.8X3.2MM	
L205	2701-000114	INDUCTOR-AXIAL:10uH,10%,2.5x3.4mm		R252	2001-000780	R-CARBON:470OHM,5%,1/8W,AA,TP,1.8X3.2MM	
L206	2701-000116	INDUCTOR-AXIAL:10uH,10%,4.2x9.8mm		R253	2001-000449	R-CARBON:2.2KOHM,5%,1/8W,AA,TP,1.8X3.2MM	
L207	2701-000114	INDUCTOR-AXIAL:10uH,10%,2.5x3.4mm		R254	2001-000429	R-CARBON:1KOHM,5%,1/8W,AA,TP,1.8X3.2MM	
L301	2701-000116	INDUCTOR-AXIAL:10uH,10%,4.2x9.8mm		R255	2001-000832	R-CARBON:510OHM,5%,1/8W,AA,TP,1.8X3.2MM	
L302	2701-000116	INDUCTOR-AXIAL:10uH,10%,4.2x9.8mm		R256	2001-000734	R-CARBON:4.7KOHM,5%,1/8W,AA,TP,1.8X3.2MM	
L303	2701-000114	INDUCTOR-AXIAL:10uH,10%,2.5x3.4mm		R257	2001-000290	R-CARBON:10KOHM,5%,1/8W,AA,TP,1.8X3.2MM	
L304	2701-000114	INDUCTOR-AXIAL:10uH,10%,2.5x3.4mm		R258	2001-000273	R-CARBON:100KOHM,5%,1/8W,AA,TP,1.8X3.2MM	
L305	2701-000116	INDUCTOR-AXIAL:10uH,10%,4.2x9.8mm		R259	2001-000003	R-CARBON:330OHM,5%,1/8W,AA,TP,1.8X3.2MM	
L401	AA27-30001B	COIL-LINEARITY:-,195uH,QIC1010,PIO,4,4.5x21.5		R260	2001-000281	R-CARBON:100OHM,5%,1/8W,AA,TP,1.8X3.2MM	
L403	2901-000297	FILTER-EMI ON BOARD:-,3A,-,3.5x5,TP,-		R261	2001-000734	R-CARBON:4.7KOHM,5%,1/8W,AA,TP,1.8X3.2MM	
L405	2701-000002	INDUCTOR-AXIAL:100uH,10%,4.2x9.8mm		R262	2001-000252	R-CARBON:1.6KOHM,5%,1/8W,AA,TP,1.8X3.2MM	
L701	2701-000114	INDUCTOR-AXIAL:10uH,10%,2.5x3.4mm		R263	2001-000780	R-CARBON:470OHM,5%,1/8W,AA,TP,1.8X3.2MM	
L703	2701-000114	INDUCTOR-AXIAL:10uH,10%,2.5x3.4mm		R264	2001-000005	R-CARBON:390OHM,5%,1/8W,AA,TP,1.8X3.2MM	
L704	2701-000114	INDUCTOR-AXIAL:10uH,10%,2.5x3.4mm		R265	2001-000563	R-CARBON:27KOHM,5%,1/8W,AA,TP,1.8X3.2MM	
L801	AA29-30001C	FILTER-LINE:-,39mH,1.0A,-,-		R267	2001-000924	R-CARBON:680OHM,5%,1/8W,AA,TP,1.8X3.2MM	
L802	3301-001223	CORE-FERRITE BEAD:AB,-,3.5X5X0.8MM,-,TPHF30-		R268	2001-000290	R-CARBON:10KOHM,5%,1/8W,AA,TP,1.8X3.2MM	
L803	AA27-20003Y	COIL-DEGAUSSING:-,20,15.2ohm,28T,L2170,E		R301	2004-000699	R-METAL:3.3Kohm,1%,1/8W,AA,TP,1.8x3.2m	
L805	3301-001223	CORE-FERRITE BEAD:AB,-,3.5X5X0.8MM,-,TPHF30-		R302	2004-004087	R-METAL(S):1.5ohm,1%,1/2W,AA,TP,2.5x6.5mm	
L809	3301-000287	CORE-FERRITE BEAD:AA,3.5x1.0x6.0mm,1500,2400G		R303	2008-000205	R-FUSIBLE(S):10ohm,5%,1/2W,AF,TP,2.5x6.5mm	
L810	2701-001032	INDUCTOR-AXIAL:100uH,10%,5x14mm		R304	2003-001032	R-METAL OXIDE(S):220ohm,5%,1W,AF,TP,2.5x6.5mm	
L812	3301-000287	CORE-FERRITE BEAD:AA,3.5x1.0x6.0mm,1500,2400G		R305	2001-000085	R-CARBON(S):100KOHM,5%,1/2W,AA,TP,2.4X6.4MM	
L813	3301-000287	CORE-FERRITE BEAD:AA,3.5x1.0x6.0mm,1500,2400G		R306	2008-000254	R-FUSIBLE(S):0.68ohm,5%,2W,AF,TP,3.9x10mm	
L817	2901-000297	FILTER-EMI ON BOARD:-,3A,-,3.5x5,TP,-		R401	2001-000281	R-CARBON:100OHM,5%,1/8W,AA,TP,1.8X3.2MM	
L902	AA27-10003G	COIL-CHOKE:-,30uH,K,50.22.3mA,TP,EL0606RA		R402	2001-000591	R-CARBON:3.3KOHM,5%,1/8W,AA,TP,1.8X3.2MM	
L904	2701-000116	INDUCTOR-AXIAL:10uH,10%,4.2x9.8mm		R403	2001-001114	R-CARBON(S):270OHM,5%,1/2W,AA,TP,2.4X6.4MM	
Q201	0501-000389	TR-SMALL SIGNAL:KSC815,NPN,400mW,TO-92,TP,120-		R404	2003-001047	R-METAL OXIDE(S):68ohm,5%,2W,AF,TP,3.9x10mm	
Q202	0501-000389	TR-SMALL SIGNAL:KSC815,NPN,400mW,TO-92,TP,120-		R405	2003-000540	R-METAL OXIDE(S):1Kohm,5%,2W,AF,TP,4x12mm	
Q203	0501-000389	TR-SMALL SIGNAL:KSC815,NPN,400mW,TO-92,TP,120-		R408	2008-000264	R-FUSIBLE(S):1ohm,5%,1W,AF,TP,3.9x10mm	
Q204	0501-000389	TR-SMALL SIGNAL:KSC815,NPN,400mW,TO-92,TP,120-		R409	2008-000204	R-FUSIBLE(S):0.22ohm,10%,1/2W,AF,TP,2.5x6.5	
Q205	0501-000389	TR-SMALL SIGNAL:KSC815,NPN,400mW,TO-92,TP,120-		R410	2008-000264	R-FUSIBLE(S):1ohm,5%,1W,AF,TP,3.9x10mm	

Electric Parts List

Loc. No.	Code No.	Description ; Specification	Remark	Loc. No.	Code No.	Description ; Specification	Remark
R412	2004-001390	R-METAL(S):1Kohm,2%,1/2W,AA,TP,2.4x6.4mm		R902	2001-000429	R-CARBON:1KOHM,5%,1/8W,AA,TP,1.8X3.2MM	
R413	2001-001037	R-CARBON(S):0.390HM,5%,1/2W,AA,TP,2.4X6.4MM		R903	2001-000429	R-CARBON:1KOHM,5%,1/8W,AA,TP,1.8X3.2MM	
R414	2001-000022	R-CARBON(S):330HM,5%,1/2W,AA,TP,2.4X6.4MM		R904	2001-000429	R-CARBON:1KOHM,5%,1/8W,AA,TP,1.8X3.2MM	
R415	2003-000993	R-METAL OXIDE(S):3.9Kohm,5%,1W,AF,TP,2.5x6.5mm		R905	2001-000449	R-CARBON:2.2KOHM,5%,1/8W,AA,TP,1.8X3.2MM	
R416	2008-000253	R-FUSIBLE(S):0.47ohm,5%,1W,AF,TP,3.9x10mm		R906	2001-000429	R-CARBON:1KOHM,5%,1/8W,AA,TP,1.8X3.2MM	
R417	2008-001005	R-FUSIBLE:0.47ohm,10%,1W,AA,TP,4.7x11.7m		R907	2001-000429	R-CARBON:1KOHM,5%,1/8W,AA,TP,1.8X3.2MM	
R418	2001-001114	R-CARBON(S):270OHM,5%,1/2W,AA,TP,2.4X6.4MM		R908	2001-000429	R-CARBON:1KOHM,5%,1/8W,AA,TP,1.8X3.2MM	
R419	2001-000563	R-CARBON:27KOHM,5%,1/8W,AA,TP,1.8X3.2MM		R910	2001-000449	R-CARBON:2.2KOHM,5%,1/8W,AA,TP,1.8X3.2MM	
R420	2004-001234	R-METAL:75Kohm,5%,1/8W,AA,TP,1.8x3.2mm		R911	2001-000290	R-CARBON:10KOHM,5%,1/8W,AA,TP,1.8X3.2MM	
R421	2003-000455	R-METAL OXIDE(S):100ohm,5%,2W,AA,TP,4x12mm		R913	2001-000429	R-CARBON:1KOHM,5%,1/8W,AA,TP,1.8X3.2MM	
R423	2004-004089	R-METAL(S):123Kohm,1%,1/2W,AA,TP,2.5x6.5m		R914	2001-000429	R-CARBON:1KOHM,5%,1/8W,AA,TP,1.8X3.2MM	
R601	2001-001114	R-CARBON(S):270OHM,5%,1/2W,AA,TP,2.4X6.4MM		R915	2001-000429	R-CARBON:1KOHM,5%,1/8W,AA,TP,1.8X3.2MM	
R604	2001-000331	R-CARBON:12KOHM,5%,1/8W,AA,TP,1.8X3.2MM		R916	2001-000429	R-CARBON:1KOHM,5%,1/8W,AA,TP,1.8X3.2MM	
R606	2001-000723	R-CARBON:4.3KOHM,5%,1/8W,AA,TP,1.8X3.2MM		R917	2001-000429	R-CARBON:1KOHM,5%,1/8W,AA,TP,1.8X3.2MM	
R609	2001-000563	R-CARBON:27KOHM,5%,1/8W,AA,TP,1.8X3.2MM		R918	2001-000429	R-CARBON:1KOHM,5%,1/8W,AA,TP,1.8X3.2MM	
R612	2008-001049	R-FUSIBLE(S):3.9ohm,5%,2W,AF,TP,3.9x10mm		R922	2001-000429	R-CARBON:1KOHM,5%,1/8W,AA,TP,1.8X3.2MM	
R613	2008-001049	R-FUSIBLE(S):3.9ohm,5%,2W,AF,TP,3.9x10mm		R923	2001-000429	R-CARBON:1KOHM,5%,1/8W,AA,TP,1.8X3.2MM	
R615	2001-000331	R-CARBON:12KOHM,5%,1/8W,AA,TP,1.8X3.2MM		R924	2001-000429	R-CARBON:1KOHM,5%,1/8W,AA,TP,1.8X3.2MM	
R702	2001-000812	R-CARBON:5.6KOHM,5%,1/8W,AA,TP,1.8X3.2MM		R925	2001-000429	R-CARBON:1KOHM,5%,1/8W,AA,TP,1.8X3.2MM	
R703	2001-000812	R-CARBON:5.6KOHM,5%,1/8W,AA,TP,1.8X3.2MM		R927	2001-000429	R-CARBON:1KOHM,5%,1/8W,AA,TP,1.8X3.2MM	
R704	2001-000290	R-CARBON:10KOHM,5%,1/8W,AA,TP,1.8X3.2MM		R928	2001-000429	R-CARBON:1KOHM,5%,1/8W,AA,TP,1.8X3.2MM	
R705	2001-000003	R-CARBON:330OHM,5%,1/8W,AA,TP,1.8X3.2MM		R930	2001-000734	R-CARBON:4.7KOHM,5%,1/8W,AA,TP,1.8X3.2MM	
R706	2001-000290	R-CARBON:10KOHM,5%,1/8W,AA,TP,1.8X3.2MM		R931	2001-000429	R-CARBON:1KOHM,5%,1/8W,AA,TP,1.8X3.2MM	
R707	2001-000290	R-CARBON:10KOHM,5%,1/8W,AA,TP,1.8X3.2MM		R932	2001-000290	R-CARBON:10KOHM,5%,1/8W,AA,TP,1.8X3.2MM	
R708	2001-000674	R-CARBON:360OHM,5%,1/8W,AA,TP,1.8X3.2MM		R933	2001-000429	R-CARBON:1KOHM,5%,1/8W,AA,TP,1.8X3.2MM	
R709	2003-000458	R-METAL OXIDE(S):100ohm,5%,2W,AF,TP,4x12mm		R934	2001-000429	R-CARBON:1KOHM,5%,1/8W,AA,TP,1.8X3.2MM	
R710	2001-000281	R-CARBON:100OHM,5%,1/8W,AA,TP,1.8X3.2MM		R935	2001-000429	R-CARBON:1KOHM,5%,1/8W,AA,TP,1.8X3.2MM	
R711	2001-000005	R-CARBON:390OHM,5%,1/8W,AA,TP,1.8X3.2MM		R936	2001-000241	R-CARBON:1.5KOHM,5%,1/8W,AA,TP,1.8X3.2MM	
R712	2001-000005	R-CARBON:390OHM,5%,1/8W,AA,TP,1.8X3.2MM		R937	2001-000969	R-CARBON:75OHM,5%,1/8W,AA,TP,1.8X3.2MM	
R713	2001-000938	R-CARBON:680HM,5%,1/8W,AA,TP,1.8X3.2MM		R938	2001-000969	R-CARBON:75OHM,5%,1/8W,AA,TP,1.8X3.2MM	
R715	2001-000290	R-CARBON:10KOHM,5%,1/8W,AA,TP,1.8X3.2MM		R939	2001-000969	R-CARBON:75OHM,5%,1/8W,AA,TP,1.8X3.2MM	
R720	2001-000290	R-CARBON:10KOHM,5%,1/8W,AA,TP,1.8X3.2MM		R940	2001-000281	R-CARBON:100OHM,5%,1/8W,AA,TP,1.8X3.2MM	
R721	2001-000633	R-CARBON:30KOHM,5%,1/8W,AA,TP,1.8X3.2MM		R941	2001-000281	R-CARBON:100OHM,5%,1/8W,AA,TP,1.8X3.2MM	
R723	2001-000290	R-CARBON:10KOHM,5%,1/8W,AA,TP,1.8X3.2MM		R942	2001-000281	R-CARBON:100OHM,5%,1/8W,AA,TP,1.8X3.2MM	
R725	2001-000969	R-CARBON:75OHM,5%,1/8W,AA,TP,1.8X3.2MM		R947	2001-000281	R-CARBON:100OHM,5%,1/8W,AA,TP,1.8X3.2MM	
R726	2001-000969	R-CARBON:75OHM,5%,1/8W,AA,TP,1.8X3.2MM		R948	2001-000281	R-CARBON:100OHM,5%,1/8W,AA,TP,1.8X3.2MM	
R728	2001-000734	R-CARBON:4.7KOHM,5%,1/8W,AA,TP,1.8X3.2MM		R949	2001-000522	R-CARBON:22KOHM,5%,1/8W,AA,TP,1.8X3.2MM	
R800A	2002-001012	R-COMPOSITION:8.2Mohm,10%,1/2W,AA,TP,3.7x9mm		R950	2001-001062	R-CARBON(S):10MOHM,5%,1/2W,AA,TP,2.4X6.4MM	
R801	2002-001011	R-COMPOSITION:3.3Mohm,10%,1/2W,AA,TP,3.7x9mm		R951	2001-000362	R-CARBON:150OHM,5%,1/8W,AA,TP,1.8X3.2MM	
R803	1404-001048	THERMISTOR-PTC:7ohm,30%,200/220V,270V,19A,-B		R952	2001-000449	R-CARBON:2.2KOHM,5%,1/8W,AA,TP,1.8X3.2MM	
R804	2001-001128	R-CARBON(S):30KOHM,5%,1/2W,AA,TP,2.4X6.4MM		R953	2001-000281	R-CARBON:100OHM,5%,1/8W,AA,TP,1.8X3.2MM	
R805	2003-000994	R-METAL OXIDE(S):33Kohm,5%,2W,AF,TP,3.9x10mm		R958	2001-000281	R-CARBON:100OHM,5%,1/8W,AA,TP,1.8X3.2MM	
R806	2003-000994	R-METAL OXIDE(S):33Kohm,5%,2W,AF,TP,3.9x10mm		R959	2001-000281	R-CARBON:100OHM,5%,1/8W,AA,TP,1.8X3.2MM	
R807	2001-000117	R-CARBON(S):68OHM,5%,1/2W,AA,TP,2.4X6.4MM		R960	2001-000281	R-CARBON:100OHM,5%,1/8W,AA,TP,1.8X3.2MM	
R808	2001-000290	R-CARBON:10KOHM,5%,1/8W,AA,TP,1.8X3.2MM		R961	2001-000734	R-CARBON:4.7KOHM,5%,1/8W,AA,TP,1.8X3.2MM	
R809	2001-001178	R-CARBON(S):680OHM,5%,1/2W,AA,TP,2.4X6.4MM		R962	2001-000734	R-CARBON:4.7KOHM,5%,1/8W,AA,TP,1.8X3.2MM	
R810	2001-001134	R-CARBON(S):360ohm,5%,1/2W,AA,BK,2.4x6.4mm		R963	2001-000734	R-CARBON:4.7KOHM,5%,1/8W,AA,TP,1.8X3.2MM	
R811	2001-001134	R-CARBON(S):360ohm,5%,1/2W,AA,BK,2.4x6.4mm		R965	2001-000429	R-CARBON:1KOHM,5%,1/8W,AA,TP,1.8X3.2MM	
R812	1404-001045	THERMISTOR-NTC:4.7ohm,15%,2900K,35.0mW,TP		R968	2001-000734	R-CARBON:4.7KOHM,5%,1/8W,AA,TP,1.8X3.2MM	
R813	2001-000022	R-CARBON(S):330HM,5%,1/2W,AA,TP,2.4X6.4MM		R969	2001-000281	R-CARBON:100OHM,5%,1/8W,AA,TP,1.8X3.2MM	
R814	2001-001125	R-CARBON(S):300KOHM,5%,1/2W,AA,TP,2.4X6.4MM		R970	2001-000281	R-CARBON:100OHM,5%,1/8W,AA,TP,1.8X3.2MM	
R815	2004-004089	R-METAL(S):123Kohm,1%,1/2W,AA,TP,2.5x6.5m		RA802	2001-001129	R-CARBON(S):330KOHM,5%,1/2W,AA,TP,2.4X6.4MM	
R816	2001-001983	R-METAL(S):2.49Kohm,1%,1/2W,AA,TP,2.4x6.4		RB802	2001-001129	R-CARBON(S):330KOHM,5%,1/2W,AA,TP,2.4X6.4MM	
R817	2001-000085	R-CARBON(S):100KOHM,5%,1/2W,AA,TP,2.4X6.4MM		RL02	2001-000281	R-CARBON:100OHM,5%,1/8W,AA,TP,1.8X3.2MM	
R818	2003-000490	R-METAL OXIDE(S):12ohm,5%,2W,AA,TP,4x12mm		RLU01	3501-001040	RELAY-POWER:12VDC,500mW,10A,1FormA,15mS,5m	
R819	2003-000664	R-METAL OXIDE(S):33ohm,5%,2W,AF,TP,4x12mm		RU102	2001-000290	R-CARBON:10KOHM,5%,1/8W,AA,TP,1.8X3.2MM	
R820	2008-000251	R-FUSIBLE(S):0.27ohm,10%,2W,AF,TP,3.9x10mm		RW701	2011-001133	R-NETWORK:33K/24K/75x3.5%,1/8W,X,SIP6P	
R821	2001-001134	R-CARBON(S):360ohm,5%,1/2W,AA,BK,2.4x6.4mm		SF101	2904-001070	FILTER-SAW AV:38.9MHz,SIP5K,TP,14.5dB,PAL-B/	
R822	2004-001390	R-METAL(S):1Kohm,2%,1/2W,AA,TP,2.4x6.4mm		T401	AA26-50001B	HORIZ.DRIVE:-,7.1mH,102uH,10-20uH,YL081.ST	
R823	2003-000616	R-METAL OXIDE(S):27ohm,5%,2W,AA,TP,4x12mm		T444	AA26-30001Y	TRANS-FLYBACK:-,FSV-20A001,20,125V	
R824	2001-000786	R-CARBON:47KOHM,5%,1/8W,AA,TP,1.8X3.2MM		T801	AA26-20007U	TRANS-SWITCHING:-,90-260V,125V/16.5V/9.5V,-EE	
R825	2006-001020	R-CEMENT:3.9ohm,5%,5W,CB,TP,10.5x14x2.3		TC01	2202-002037	C-CERAMIC,MLC-AXIAL:100nF,80-20%,50V,Y5V,TP,2.2x3.	
R827	2003-000713	R-METAL OXIDE(S):47ohm,5%,2W,AF,TP,4x12mm		TC02	2202-000143	C-CERAMIC,MLC-AXIAL:10pF,5%,50V,NPO,TP,1.9x3.5,-	
R828	2001-000734	R-CARBON:4.7KOHM,5%,1/8W,AA,TP,1.8X3.2MM		TC03	2202-000162	C-CERAMIC,MLC-AXIAL:.015NF,5%,50V,SL,TP,3.5X1.9MM,-	
R829	2001-000734	R-CARBON:4.7KOHM,5%,1/8W,AA,TP,1.8X3.2MM		TC04	2202-000796	C-CERAMIC,MLC-AXIAL:1NF,10%,50V,Y5P,TP,3.5X1.9MM,-	
R830	2001-000864	R-CARBON:56KOHM,5%,1/8W,AA,TP,1.8X3.2MM		TC05	2202-002037	C-CERAMIC,MLC-AXIAL:100nF,80-20%,50V,Y5V,TP,2.2x3.	
R831	2003-001098	R-METAL OXIDE(S):22Kohm,5%,3W,AA,TP,6x16mm		TC06	2202-002037	C-CERAMIC,MLC-AXIAL:100nF,80-20%,50V,Y5V,TP,2.2x3.	
R832	2001-000786	R-CARBON:47KOHM,5%,1/8W,AA,TP,1.8X3.2MM		TC07	2202-002037	C-CERAMIC,MLC-AXIAL:100nF,80-20%,50V,Y5V,TP,2.2x3.	
R834	2003-000664	R-METAL OXIDE(S):33ohm,5%,2W,AF,TP,4x12mm		TC08	2202-002037	C-CERAMIC,MLC-AXIAL:100nF,80-20%,50V,Y5V,TP,2.2x3.	
R835	2003-000760	R-METAL OXIDE(S):6.8ohm,5%,2W,AA,TP,4x12mm		TC09	2202-002037	C-CERAMIC,MLC-AXIAL:100nF,80-20%,50V,Y5V,TP,2.2x3.	
R836	2003-000760	R-METAL OXIDE(S):6.8ohm,5%,2W,AA,TP,4x12mm		TC11	2401-000242	C-AL:100uF,20%,10V,GP,TP,5x11.5	
R837	2003-000490	R-METAL OXIDE(S):12ohm,5%,2W,AA,TP,4x12mm		TC12	2202-000791	C-CERAMIC,MLC-AXIAL:150pF,10%,50V,Y5P,TP,3.5x19.-	
R856	2003-000803	R-METAL OXIDE(S):82Kohm,5%,2W,AA,TP,4x12mm		TD02	0401-000005	DIODE-SWITCHING:1N4148,75V,200MA,DO-35,TP	
R858	2003-000706	R-METAL OXIDE(S):47Kohm,5%,2W,AA,TP,4.3x12mm		TD04	0401-000005	DIODE-SWITCHING:1N4148,75V,200MA,DO-35,TP	
R860	2001-001054	R-CARBON(S):1.6KOHM,5%,1/2W,AA,TP,2.4X6.4MM		TD06	0401-000005	DIODE-SWITCHING:1N4148,75V,200MA,DO-35,TP	
R869	2008-000253	R-FUSIBLE(S):0.47ohm,5%,1W,AF,TP,3.9x10mm		TD07	0401-000005	DIODE-SWITCHING:1N4148,75V,200MA,DO-35,TP	
R901	2001-000429	R-CARBON:1KOHM,5%,1/8W,AA,TP,1.8X3.2MM		TIC01	1204-000523	IC-PAL DECODER:SAA5254,DIP,40P,-PLASTIC,6.5V	

Loc. No.	Code No.	Description ; Specification	Remark	Loc. No.	Code No.	Description ; Specification	Remark
TL01	2701-000170	INDUCTOR-AXIAL:3.9uH,10%,2.8x7mm		CM314	2202-000216	C-CERAMIC,MLC-AXIAL:;027NF,5%,50V,SL,TP,3.5X1.9MM,-	
TR01	2001-000232	R-CARBON:1.3KOHM,5%,1/8W,AA,TP,1.8X3.2MM		CM315	2201-002031	C-CERAMIC,DISC:5pF,0.25pF,50V,NPO,TP,5x3mm,5m	
TR02	2001-000429	R-CARBON:1KOHM,5%,1/8W,AA,TP,1.8X3.2MM		CM316	2202-000862	C-CERAMIC,MLC-AXIAL:390pF,10%,50V,Y5P,TP,3.5x1.9,-	
TR04	2001-000563	R-CARBON:27KOHM,5%,1/8W,AA,TP,1.8X3.2MM		CM317	2401-000603	C-AL:1uF,20%,50V,GP,TP,5x11,5	
TR05	2001-000734	R-CARBON:4.7KOHM,5%,1/8W,AA,TP,1.8X3.2MM		CM318	2202-000162	C-CERAMIC,MLC-AXIAL:;015NF,5%,50V,SL,TP,3.5X1.9MM,-	
TR06	2001-000734	R-CARBON:4.7KOHM,5%,1/8W,AA,TP,1.8X3.2MM		CM319	2201-000345	C-CERAMIC,DISC:200pF,5%,50V,SL,TP,6.3*3,5	
TR07	2001-000734	R-CARBON:4.7KOHM,5%,1/8W,AA,TP,1.8X3.2MM		CM320	2202-000849	C-CERAMIC,MLC-AXIAL:18pF,5%,50V,CH,TP,3.5x1.9,-	
TR08	2001-000281	R-CARBON:100OHM,5%,1/8W,AA,TP,1.8X3.2MM		CM321	2202-000127	C-CERAMIC,MLC-AXIAL:10nF,+80-20%,25V,Y5V,TP,-,7.5	
TR09	2001-000281	R-CARBON:100OHM,5%,1/8W,AA,TP,1.8X3.2MM		CM322	2401-001363	C-AL:470uF,20%,16V,GP,TP,10x12,5,5	
TR10	2001-000281	R-CARBON:100OHM,5%,1/8W,AA,TP,1.8X3.2MM		CM323	2401-002235	C-AL:10uF,20%,16V,GP,TP,5x11mm,5mm	
TR13	2001-000472	R-CARBON:2.7KOHM,5%,1/8W,AA,TP,1.8X3.2MM		CM324	2401-000914	C-AL:22uF,20%,16V,GP,TP,5x11,5	
4 TU001	AA40-10006V	TUNER-F/S:TECC2949PG30B(S),PAL-B/G,TR,18		CM325	2202-000796	C-CERAMIC,MLC-AXIAL:1nF,10%,50V,Y5P,TP,3.5X1.9MM,-	
TU002	AA40-10006T	TUNER-F/S:TECC2849PG29A(S),PAL-B/G,TR,18		CM326	2401-001333	C-AL:470nF,20%,50V,GP,TP,5x11,5	
TX01	2801-001478	CRYSTAL-UNIT;27.0MHz,25ppm,28-ABR,20pF,40oh		CM327	2202-002037	C-CERAMIC,MLC-AXIAL:100nF,80-20%,50V,Y5V,TP,2.2x3.	
X202	2801-000274	CRYSTAL-UNIT;4.433619MHz,30ppm,28-AAM,20pF,		CM328	2401-002235	C-AL:10uF,20%,16V,GP,TP,5x11mm,5mm	
X901	2801-001480	CRYSTAL-UNIT;4.194304MHz,20ppm,28-ABO,12pF,		CM329	2202-002037	C-CERAMIC,MLC-AXIAL:100nF,80-20%,50V,Y5V,TP,2.2x3.	
Z101	2903-001019	FILTER-CERAMIC;TR,5.5/5.6,0/6.5MHz,-,-,-,TP,		CM331	2401-000603	C-AL:1uF,20%,50V,GP,TP,5x11,5	
Z102	2903-001040	FILTER-CERAMIC;TR,5.5/5.6,0/6.5MHz,-,-,-,TP,		CM332	2401-002235	C-AL:10uF,20%,16V,GP,TP,5x11mm,5mm	
ZK01	2903-000184	FILTER-CERAMIC;BP,5.5MHz,+60KHz,6dB,-,-,TP,		CM333	2401-000598	C-AL:1uF,20%,50V,GP,TP,4x7,5	
ZK02	2903-000184	FILTER-CERAMIC;BP,5.5MHz,+60KHz,6dB,-,-,TP,		CM334	2202-000127	C-CERAMIC,MLC-AXIAL:10nF,+80-20%,25V,Y5V,TP,-,7.5	
				CM335	2202-000127	C-CERAMIC,MLC-AXIAL:10nF,+80-20%,25V,Y5V,TP,-,7.5	
				CM336	2202-000127	C-CERAMIC,MLC-AXIAL:10nF,+80-20%,25V,Y5V,TP,-,7.5	
				CM337	2202-000127	C-CERAMIC,MLC-AXIAL:10nF,+80-20%,25V,Y5V,TP,-,7.5	
				CM338	2202-000127	C-CERAMIC,MLC-AXIAL:10nF,+80-20%,25V,Y5V,TP,-,7.5	
				CM339	2202-002037	C-CERAMIC,MLC-AXIAL:100nF,80-20%,50V,Y5V,TP,2.2x3.	
				CM340	2401-002144	C-AL:47uF,20%,16V,GP,TP,5x11,5	
				CM341	2202-000127	C-CERAMIC,MLC-AXIAL:10nF,+80-20%,25V,Y5V,TP,-,7.5	
				CM342	2202-002037	C-CERAMIC,MLC-AXIAL:100nF,80-20%,50V,Y5V,TP,2.2x3.	
				CM343	2401-002144	C-AL:47uF,20%,16V,GP,TP,5x11,5	
				CM344	2401-000598	C-AL:1uF,20%,50V,GP,TP,4x7,5	
				CM345	2202-000819	C-CERAMIC,MLC-AXIAL:47nF,+80-20%,50V,Y5V,TP,3.5x19	
				CM346	2401-000598	C-AL:1uF,20%,50V,GP,TP,4x7,5	
				CM347	2202-000807	C-CERAMIC,MLC-AXIAL:22nF,+80-20%,25V,Y5V,TP,3.5x19	
				CM348	2401-000598	C-AL:1uF,20%,50V,GP,TP,4x7,5	
				CM349	2202-000127	C-CERAMIC,MLC-AXIAL:10nF,+80-20%,25V,Y5V,TP,-,7.5	
				CM350	2202-000819	C-CERAMIC,MLC-AXIAL:47nF,+80-20%,50V,Y5V,TP,3.5x19	
				CM351	2202-000807	C-CERAMIC,MLC-AXIAL:22nF,+80-20%,25V,Y5V,TP,3.5x19	
				CM352	2202-002037	C-CERAMIC,MLC-AXIAL:100nF,80-20%,50V,Y5V,TP,2.2x3.	
				CM353	2401-002144	C-AL:47uF,20%,16V,GP,TP,5x11,5	
				CM354	2202-002037	C-CERAMIC,MLC-AXIAL:100nF,80-20%,50V,Y5V,TP,2.2x3.	
				CM355	2401-000914	C-AL:22uF,20%,16V,GP,TP,5x11,5	
				CM356	2401-002462	C-AL:33uF,20%,16V,GP,TP,5x11,5	
				CM357	2401-002619	C-AL:47uF,20%,25V,GP,TP,5x11,5	
				CM358	2202-002037	C-CERAMIC,MLC-AXIAL:100nF,80-20%,50V,Y5V,TP,2.2x3.	
				CM359	2201-000611	C-CERAMIC,DISC:56pF,5%,50V,CH,TP,6.5x3,5	
				CM360	2201-000611	C-CERAMIC,DISC:56pF,5%,50V,CH,TP,6.5x3,5	
				CM361	2201-000982	C-CERAMIC,DISC:10nF,+80-20%,50V,Y5V,TP,6.5x3,	
BDM301	3301-000287	CORE-FERRITE BEAD;AA,3.5x1.0x6.0mm,1500,2400G		CM362	2301-000301	C-FILM,PEF:6.8nF,5%,50V,TP,6.5X5.5X3.0X5,	
BDM303	3301-000287	CORE-FERRITE BEAD;AA,3.5x1.0x6.0mm,1500,2400G		CM363	2301-000301	C-FILM,PEF:6.8nF,5%,50V,TP,6.5X5.5X3.0X5,	
CM101	2401-000603	C-AL:1uF,20%,50V,GP,TP,5x11,5		CM364	2301-000314	C-FILM,PEF:8.2nF,5%,50V,TP,6.5X3.0X5,5mm,	
CM102	2401-000603	C-AL:1uF,20%,50V,GP,TP,5x11,5		CM365	2401-000027	C-AL:4.7uF,20%,50V,GP,TP,5x11,5	
CM103	2401-000832	C-AL:220uF,20%,25V,GP,TP,8x11,5,5		CM367	2202-002037	C-CERAMIC,MLC-AXIAL:100nF,80-20%,50V,Y5V,TP,2.2x3.	
CM104	2401-000302	C-AL:100uF,20%,25V,GP,TP,6.3x11,5		CM368	2301-000175	C-FILM,PEF:15nF,5%,50V,TP,7.1x3.5x13mm,5m	
CM105	2401-000302	C-AL:100uF,20%,25V,GP,TP,6.3x11,5		CM370	2301-000254	C-FILM,PEF:39nF,5%,50V,TP,7.5x3.5x6.5mm,5	
CM106	2401-000480	C-AL:10uF,20%,50V,GP,TP,5x11,5		CM371	2301-000301	C-FILM,PEF:6.8nF,5%,50V,TP,6.5X5.5X3.0X5,	
CM107	2202-002037	C-CERAMIC,MLC-AXIAL:100nF,80-20%,50V,Y5V,TP,2.2x3.		CM372	2301-000160	C-FILM,PEF:12nF,5%,50V,TP,11.0x6.0x9.0mm,	
CM108	2202-002037	C-CERAMIC,MLC-AXIAL:100nF,80-20%,50V,Y5V,TP,2.2x3.		CM373	2401-002144	C-AL:47uF,20%,16V,GP,TP,5x11,5	
CM109	2401-000480	C-AL:10uF,20%,50V,GP,TP,5x11,5		CM374	2202-002037	C-CERAMIC,MLC-AXIAL:100nF,80-20%,50V,Y5V,TP,2.2x3.	
CM110	2401-000302	C-AL:100uF,20%,25V,GP,TP,6.3x11,5		CM375	2401-002009	C-AL:100uF,20%,16V,GP,TP,6.3x7,5	
CM111	2401-000302	C-AL:100uF,20%,25V,GP,TP,6.3x11,5		CM376	2202-002037	C-CERAMIC,MLC-AXIAL:100nF,80-20%,50V,Y5V,TP,2.2x3.	
CM112	2202-002037	C-CERAMIC,MLC-AXIAL:100nF,80-20%,50V,Y5V,TP,2.2x3.		CM377	2202-000127	C-CERAMIC,MLC-AXIAL:10nF,+80-20%,25V,Y5V,TP,-,7.5	
CM113	2401-000832	C-AL:220uF,20%,25V,GP,TP,8x11,5,5		CM378	2202-000127	C-CERAMIC,MLC-AXIAL:10nF,+80-20%,25V,Y5V,TP,-,7.5	
CM114	2202-002037	C-CERAMIC,MLC-AXIAL:100nF,80-20%,50V,Y5V,TP,2.2x3.		CM379	2202-000127	C-CERAMIC,MLC-AXIAL:10nF,+80-20%,25V,Y5V,TP,-,7.5	
CM115	2202-002037	C-CERAMIC,MLC-AXIAL:100nF,80-20%,50V,Y5V,TP,2.2x3.		CM380	2202-000127	C-CERAMIC,MLC-AXIAL:10nF,+80-20%,25V,Y5V,TP,-,7.5	
CM116	2202-000796	C-CERAMIC,MLC-AXIAL:1nF,10%,50V,Y5P,TP,3.5X1.9MM,-		CM383	2202-000830	C-CERAMIC,MLC-AXIAL:82pF,10%,50V,Y5P,TP,3.5x19,-	
CM117	2202-002037	C-CERAMIC,MLC-AXIAL:100nF,80-20%,50V,Y5V,TP,2.2x3.		CM385	2202-002037	C-CERAMIC,MLC-AXIAL:100nF,80-20%,50V,Y5V,TP,2.2x3.	
CM301	2202-002037	C-CERAMIC,MLC-AXIAL:100nF,80-20%,50V,Y5V,TP,2.2x3.		CM387	2202-000127	C-CERAMIC,MLC-AXIAL:10nF,+80-20%,25V,Y5V,TP,-,7.5	
CM303	2301-000383	C-FILM,PEF:10nF,5%,50V,TP,6x7x3.2mm,5mm		CM389	2202-002037	C-CERAMIC,MLC-AXIAL:100nF,80-20%,50V,Y5V,TP,2.2x3.	
CM304	2401-000426	C-AL:10uF,20%,16V,GP,TP,3.5x5,5		CM390	2202-002037	C-CERAMIC,MLC-AXIAL:100nF,80-20%,50V,Y5V,TP,2.2x3.	
CM305	2301-000342	C-FILM,PEF:2.2nF,5%,50V,TP,7.4x3.9x13mm,5		CM391	2202-002037	C-CERAMIC,MLC-AXIAL:100nF,80-20%,50V,Y5V,TP,2.2x3.	
CM306	2301-000192	C-FILM,PEF:1nF,5%,50V,TP,5.3x10mm,5mm		CM392	2401-000603	C-AL:1uF,20%,50V,GP,TP,5x11,5	
CM307	2401-001250	C-AL:4.7uF,20%,35V,GP,TP,4x5,5		CM393	2202-002037	C-CERAMIC,MLC-AXIAL:100nF,80-20%,50V,Y5V,TP,2.2x3.	
CM308	2401-000660	C-AL:2.2uF,20%,50V,GP,TP,5x11,5		CM395	2202-000279	C-CERAMIC,MLC-AXIAL:47pF,5%,50V,SL,TP,3.5x19,-	
CM309	2305-000427	C-FILM,MPEF:47nF,5%,100V,TP,7.5x12.5x3.5,5		CM397	2202-000127	C-CERAMIC,MLC-AXIAL:10nF,+80-20%,25V,Y5V,TP,-,7.5	
CM310	2401-000603	C-AL:1uF,20%,50V,GP,TP,5x11,5		CM601	2202-000806	C-CERAMIC,MLC-AXIAL:220pF,10%,50V,Y5P,TP,3.5x19,-	
CM311	2202-002037	C-CERAMIC,MLC-AXIAL:100nF,80-20%,50V,Y5V,TP,2.2x3.		CM602	2301-000310	C-FILM,PEF:68nF,5%,50V,TP,8.0X8.5X4.0X5,5	
CM312	2401-002291	C-AL:47uF,20%,16V,GP,TP,6.3x5,5		CM603	2301-000310	C-FILM,PEF:68nF,5%,50V,TP,8.0X8.5X4.0X5,5	
CM313	2202-000127	C-CERAMIC,MLC-AXIAL:10nF,+80-20%,25V,Y5V,TP,-,7.5					

Electric Parts List

Loc. No.	Code No.	Description ; Specification	Remark	Loc. No.	Code No.	Description ; Specification	Remark
CM604	2301-000224	C-FILM,PEF:22nF,5%,50V,TP,7.4x3.9x13mm,5m		LM307	2701-000002	INDUCTOR-AXIAL:100uH,10%,4.2x9.8mm	
CM605	2401-002291	C-AL:47uF,20%,16V,GP,TP,6.3x5,5		LM308	2702-000120	INDUCTOR-RADIAL:15mH,5%,6.2x7.4mm	
CM606	2202-002037	C-CERAMIC,MLC-AXIAL:100nF,80-20%,50V,Y5V,TP,2.2x3.		LM309	2701-000112	INDUCTOR-AXIAL:100uH,10%,2.8x7mm	
CM607	2202-000205	C-CERAMIC,MLC-AXIAL:22pF,5%,50V,SL,TP,1.9x3.5,-		LM310	2701-000180	INDUCTOR-AXIAL:33uH,5%,2.5x3.4mm	
CM608	2202-000205	C-CERAMIC,MLC-AXIAL:22pF,5%,50V,SL,TP,1.9x3.5,-		LM311	2701-000118	INDUCTOR-AXIAL:120uH,10%,2.5x3.4mm	
CM609	2202-000205	C-CERAMIC,MLC-AXIAL:22pF,5%,50V,SL,TP,1.9x3.5,-		LM601	2701-000002	INDUCTOR-AXIAL:100uH,10%,4.2x9.8mm	
CM610	2202-000205	C-CERAMIC,MLC-AXIAL:22pF,5%,50V,SL,TP,1.9x3.5,-		LM602	2701-000002	INDUCTOR-AXIAL:100uH,10%,4.2x9.8mm	
CM611	2401-000598	C-AL:1uF,20%,50V,GP,TP,4x7,5		LM603	2701-000002	INDUCTOR-AXIAL:100uH,10%,4.2x9.8mm	
CM612	2202-000127	C-CERAMIC,MLC-AXIAL:10nF,+80-20%,25V,Y5V,TP,-,7.5		LM604	2701-000002	INDUCTOR-AXIAL:100uH,10%,4.2x9.8mm	
CM613	2202-000127	C-CERAMIC,MLC-AXIAL:10nF,+80-20%,25V,Y5V,TP,-,7.5		LM605	2701-000002	INDUCTOR-AXIAL:100uH,10%,4.2x9.8mm	
CM614	2401-001250	C-AL:4.7uF,20%,35V,GP,TP,4x5,5		PTM601	0604-001122	PHOTO-INTERRUPTER:TR,0.065%,150mW,DIP,4,BK	
CM615	2202-000127	C-CERAMIC,MLC-AXIAL:10nF,+80-20%,25V,Y5V,TP,-,7.5		PTM602	0604-001122	PHOTO-INTERRUPTER:TR,0.065%,150mW,DIP,4,BK	
CM616	2401-002619	C-AL:47uF,20%,25V,GP,TP,5x11,5		QM101	0501-000316	TR-SMALL SIGNAL:KSA928A-Y,PNP,1W,TO-92L,-,160-	
CM617	2401-002619	C-AL:47uF,20%,25V,GP,TP,5x11,5		QM102	0504-000116	TR-DIGITAL:KSR1001,NPN,300MW,4.7K/4.7K,TO-92,TP	
CM621	2401-000302	C-AL:100uF,20%,25V,GP,TP,6.3x11,5		QM106	0501-000362	TR-SMALL SIGNAL:KSA2328A-Y,NPN,1W,TO-92L,TP,16	
CM622	2202-000127	C-CERAMIC,MLC-AXIAL:10nF,+80-20%,25V,Y5V,TP,-,7.5		QM107	0501-000362	TR-SMALL SIGNAL:KSA2328A-Y,NPN,1W,TO-92L,TP,16	
CM623	2401-000302	C-AL:100uF,20%,25V,GP,TP,6.3x11,5		QM301	0501-000398	TR-SMALL SIGNAL:KSC945,NPN,250mW,TO-92,TP,120-	
CM624	2202-000127	C-CERAMIC,MLC-AXIAL:10nF,+80-20%,25V,Y5V,TP,-,7.5		QM302	0501-000398	TR-SMALL SIGNAL:KSC945,NPN,250mW,TO-92,TP,120-	
CM627	2401-000302	C-AL:100uF,20%,25V,GP,TP,6.3x11,5		QM304	0501-000303	TR-SMALL SIGNAL:KSA733,PNP,250mW,TO-92,TP,120-	
CM628	2202-000127	C-CERAMIC,MLC-AXIAL:10nF,+80-20%,25V,Y5V,TP,-,7.5		QM305	0501-000303	TR-SMALL SIGNAL:KSA733,PNP,250mW,TO-92,TP,120-	
CM629	2202-002037	C-CERAMIC,MLC-AXIAL:100nF,80-20%,50V,Y5V,TP,2.2x3.		QM306	0501-000398	TR-SMALL SIGNAL:KSC945,NPN,250mW,TO-92,TP,120-	
CM630	2202-002037	C-CERAMIC,MLC-AXIAL:100nF,80-20%,50V,Y5V,TP,2.2x3.		QM308	0501-000398	TR-SMALL SIGNAL:KSC945,NPN,250mW,TO-92,TP,120-	
CM633	2202-002037	C-CERAMIC,MLC-AXIAL:100nF,80-20%,50V,Y5V,TP,2.2x3.		QM311	0501-000303	TR-SMALL SIGNAL:KSA733,PNP,250mW,TO-92,TP,120-	
CM634	2202-000127	C-CERAMIC,MLC-AXIAL:10nF,+80-20%,25V,Y5V,TP,-,7.5		QM312	0501-000010	TR-SMALL SIGNAL:KSC1008,NPN,800mW,TO-92,TP,120	
CM635	2202-000127	C-CERAMIC,MLC-AXIAL:10nF,+80-20%,25V,Y5V,TP,-,7.5		QM313	0501-000231	TR-SMALL SIGNAL:2SD1468SQ,NPN,300mW,TO-92S,TP,	
CM636	2202-000183	C-CERAMIC,MLC-AXIAL:2.2NF,20%,16V,Y5R,TP,3.5X1.9MM,		QM314	0501-000231	TR-SMALL SIGNAL:2SD1468SQ,NPN,300mW,TO-92S,TP,	
CM637	2202-000183	C-CERAMIC,MLC-AXIAL:2.2NF,20%,16V,Y5R,TP,3.5X1.9MM,		QM315	0501-000303	TR-SMALL SIGNAL:KSA733,PNP,250mW,TO-92,TP,120-	
CM638	2202-000263	C-CERAMIC,MLC-AXIAL:470pF,10%,50V,Y5P,TP,3.5x19,-		QM317	0501-000389	TR-SMALL SIGNAL:KSC815,NPN,400mW,TO-92,TP,120-	
CM639	2401-000922	C-AL:22uF,20%,16V,GP,TP,5x5,5		RM101	2001-000273	R-CARBON:100KOHM,5%,1/8W,AA,TP,1.8X3.2MM	
CM640	2202-000121	C-CERAMIC,MLC-AXIAL:100pF,10%,50V,Y5P,TP,1.9x3.5,-		RM102	2001-001122	R-CARBON(S):3.9KOHM,5%,1/2W,AA,TP,2.4X6.4MM	
CM641	2401-002009	C-AL:100uF,20%,16V,GP,TP,6.3x7,5		RM103	2001-000449	R-CARBON:2.2KOHM,5%,1/8W,AA,TP,1.8X3.2MM	
CM642	2202-002037	C-CERAMIC,MLC-AXIAL:100nF,80-20%,50V,Y5V,TP,2.2x3.		RM106	2001-000449	R-CARBON:2.2KOHM,5%,1/8W,AA,TP,1.8X3.2MM	
CM645	2202-002037	C-CERAMIC,MLC-AXIAL:100nF,80-20%,50V,Y5V,TP,2.2x3.		RM107	2001-001107	R-CARBON(S):220OHM,5%,1/2W,AA,TP,2.4x6.4mm	
CM647	2401-002291	C-AL:47uF,20%,16V,GP,TP,6.3x5,5		RM108	2001-000674	R-CARBON:360OHM,5%,1/8W,AA,TP,1.8X3.2MM	
CM649	2202-002037	C-CERAMIC,MLC-AXIAL:100nF,80-20%,50V,Y5V,TP,2.2x3.		RM302	2001-000812	R-CARBON:5.6KOHM,5%,1/8W,AA,TP,1.8X3.2MM	
CM651	2202-002037	C-CERAMIC,MLC-AXIAL:100nF,80-20%,50V,Y5V,TP,2.2x3.		RM303	2001-000331	R-CARBON:12KOHM,5%,1/8W,AA,TP,1.8X3.2MM	
CNM1101	AA39-20607A	LEAD CONNECTOR-ASSY:-,YBNH250-10,67096-10,10P,300		RM304	2001-000645	R-CARBON:330KOHM,5%,1/8W,AA,TP,1.8X3.2MM	
CNM1102	AA39-20071D	LEAD-CONNECTOR,ASSY:-,YBNH025-12,67096-012,12P,300		RM305	2001-000384	R-CARBON:160OHM,5%,1/8W,AA,TP,1.8X3.2MM	
CNM301	3708-000395	CONNECTOR-FPC/FC/PIC:8P,1.25mm,STRAIGHT,SN		RM306	2001-000660	R-CARBON:33KOHM,5%,1/8W,AA,TP,1.8X3.2MM	
CNM302	3708-001053	CONNECTOR-FPC/FC/PIC:7P,1.25mm,STRAIGHT,SN		RM307	2001-000241	R-CARBON:1.5KOHM,5%,1/8W,AA,TP,1.8X3.2MM	
CNM303	3710-000405	CONNECTOR-SOCKET:2P,2R,2.5mm,-,		RM310	2001-000429	R-CARBON:1KOHM,5%,1/8W,AA,TP,1.8X3.2MM	
CNM51A	3809-001111	CABLE-FLAT:30V,80C,130mm,7P,1.25mm,UL2896		RM312	2001-000429	R-CARBON:1KOHM,5%,1/8W,AA,TP,1.8X3.2MM	
CNM601	AA39-20603A	LEAD CONNECTOR-ASSY:-,GIL-S-2S-S2C2-S,YBH200-02,2P		RM313	2001-000472	R-CARBON:2.2KOHM,5%,1/8W,AA,TP,1.8X3.2MM	
CNM602	3708-001131	CONNECTOR-FPC/FC/PIC:5P,1.25mm,STRAIGHT,SN		RM314	2001-000924	R-CARBON:680OHM,5%,1/8W,AA,TP,1.8X3.2MM	
CNM603	3711-003749	CONNECTOR-HEADER:BOX,8P,2R,2mm,STRAIGHT,SN		RM315	2001-000515	R-CARBON:220OHM,5%,1/8W,AA,TP,1.8X3.2MM	
CNM611	3711-000683	CONNECTOR-HEADER:BOX,13P,1R,2mm,STRAIGHT,SN		RM316	2001-000221	R-CARBON:1.2KOHM,5%,1/8W,AA,TP,1.8X3.2MM	
CNM64A	3809-001112	CABLE-FLAT:30V,80C,130mm,5P,1.25mm,UL2896		RM317	2001-000429	R-CARBON:1KOHM,5%,1/8W,AA,TP,1.8X3.2MM	
DM1101	0402-000132	DIODE-RECTIFIER:1N4004,400V,1A,DO-41,TP		RM318	2001-000003	R-CARBON:330OHM,5%,1/8W,AA,TP,1.8X3.2MM	
DM1102	0402-000132	DIODE-RECTIFIER:1N4004,400V,1A,DO-41,TP		RM319	2001-000003	R-CARBON:330OHM,5%,1/8W,AA,TP,1.8X3.2MM	
DM1104	0402-000132	DIODE-RECTIFIER:1N4004,400V,1A,DO-41,TP		RM323	2001-000241	R-CARBON:1.5KOHM,5%,1/8W,AA,TP,1.8X3.2MM	
DM1107	0401-000005	DIODE-SWITCHING:1N4148,75V,200MA,DO-35,TP		RM324	2001-000734	R-CARBON:4.7KOHM,5%,1/8W,AA,TP,1.8X3.2MM	
DM1108	0402-000132	DIODE-RECTIFIER:1N4004,400V,1A,DO-41,TP		RM325	2001-000515	R-CARBON:220OHM,5%,1/8W,AA,TP,1.8X3.2MM	
DM1109	0401-000005	DIODE-SWITCHING:1N4148,75V,200MA,DO-35,TP		RM327	2001-000281	R-CARBON:100OHM,5%,1/8W,AA,TP,1.8X3.2MM	
DM1110	0402-000132	DIODE-RECTIFIER:1N4004,400V,1A,DO-41,TP		RM328	2001-000800	R-CARBON:5.1KOHM,5%,1/8W,AA,TP,1.8X3.2MM	
DM1111	0402-000132	DIODE-RECTIFIER:1N4004,400V,1A,DO-41,TP		RM329	2001-000969	R-CARBON:750OHM,5%,1/8W,AA,TP,1.8X3.2MM	
DM305	0401-000005	DIODE-SWITCHING:1N4148,75V,200MA,DO-35,TP		RM330	2001-000037	R-CARBON(S):330OHM,5%,1/2W,AA,TP,2.4X6.4MM	
DM601	0401-000005	DIODE-SWITCHING:1N4148,75V,200MA,DO-35,TP		RM331	2001-000723	R-CARBON:4.3KOHM,5%,1/8W,AA,TP,1.8X3.2MM	
DM602	0401-000005	DIODE-SWITCHING:1N4148,75V,200MA,DO-35,TP		RM333	2001-000429	R-CARBON:1KOHM,5%,1/8W,AA,TP,1.8X3.2MM	
DM606	0402-000132	DIODE-RECTIFIER:1N4004,400V,1A,DO-41,TP		RM334	2001-000472	R-CARBON:2.7KOHM,5%,1/8W,AA,TP,1.8X3.2MM	
DM610	0402-000132	DIODE-RECTIFIER:1N4004,400V,1A,DO-41,TP		RM335	2001-000232	R-CARBON:1.3KOHM,5%,1/8W,AA,TP,1.8X3.2MM	
DM611	0401-000005	DIODE-SWITCHING:1N4148,75V,200MA,DO-35,TP		RM338	2001-000977	R-CARBON:8.2KOHM,5%,1/8W,AA,TP,1.8X3.2MM	
FLM301	AA26-10006C	TRANS-IF:-,7MF,BIAS,2.4MH,7MM,-,65.3KHZ,ST,-		RM339	2001-000258	R-CARBON:1.8KOHM,5%,1/8W,AA,TP,1.8X3.2MM	
GPM001	AA63-40311A	GROUND-PLATE,POB:-,PBS,TO.3,TVN334V,-		RM340	2001-000449	R-CARBON:2.2KOHM,5%,1/8W,AA,TP,1.8X3.2MM	
ICM101	1203-000165	IC-POSI.ADJUST REG.:78R12,TO-220,3P,-,12V,-,Oto+		RM341	2001-000429	R-CARBON:1KOHM,5%,1/8W,AA,TP,1.8X3.2MM	
ICM102	1203-000298	IC-POSI.FIXED REG.:7809,TO-220,3P,-,PLASTIC,8.65/		RM342	2001-000766	R-CARBON:43KOHM,5%,1/8W,AA,TP,1.8X3.2MM	
ICM301	1204-001410	IC-VIDEO PROCESS:LA71590M,QFP,100P,-,PLASTIC,7V		RM343	2001-000947	R-CARBON:7.5KOHM,5%,1/8W,AA,TP,1.8X3.2MM	
ICM601	AA13-00011A	IC-MCU:-,UPD784927-107,8BIT,CHIP,TF-502V,100,14X20		RM344	2001-000454	R-CARBON:2.2MOHM,5%,1/8W,AA,TP,1.8X3.2MM	
ICM602	1003-001162	IC-MOTOR DRIVER:KA3082,SIP,10PIN,25MIL,DOUBLE,		RM345	2001-000734	R-CARBON:4.7KOHM,5%,1/8W,AA,TP,1.8X3.2MM	
ICM603	1203-000642	IC-RESET:572,TO-92,3P,-,PLASTIC,2.35/2.5		RM346	2001-000472	R-CARBON:2.7KOHM,5%,1/8W,AA,TP,1.8X3.2MM	
LDM601	AA91-60318A	ASSY-HOLDER,LED:-,ABS,HB,BLK,IR,LED,TS-DECK		RM347	2001-000832	R-CARBON:510OHM,5%,1/8W,AA,TP,1.8X3.2MM	
LM101	2701-000002	INDUCTOR-AXIAL:100uH,10%,4.2x9.8mm		RM348	2001-000832	R-CARBON:510OHM,5%,1/8W,AA,TP,1.8X3.2MM	
LM301	2701-000002	INDUCTOR-AXIAL:100uH,10%,4.2x9.8mm		RM349	2001-000221	R-CARBON:1.2KOHM,5%,1/8W,AA,TP,1.8X3.2MM	
LM302	2701-000207	INDUCTOR-AXIAL:56uH,5%,2.5x3.4mm		RM350	2001-000812	R-CARBON:5.6KOHM,5%,1/8W,AA,TP,1.8X3.2MM	
LM303	2701-000118	INDUCTOR-AXIAL:120uH,10%,2.5x3.4mm		RM351	2001-000800	R-CARBON:5.1KOHM,5%,1/8W,AA,TP,1.8X3.2MM	
LM304	2701-000002	INDUCTOR-AXIAL:100uH,10%,4.2x9.8mm		RM352	2001-000006	R-CARBON:2.4KOHM,5%,1/8W,AA,TP,1.8X3.2MM	
LM305	2701-000002	INDUCTOR-AXIAL:100uH,10%,4.2x9.8mm		RM353	2001-000904	R-CARBON:620OHM,5%,1/8W,AA,TP,1.8X3.2MM	
LM306	2701-000002	INDUCTOR-AXIAL:100uH,10%,4.2x9.8mm		RM354	2001-000522	R-CARBON:22KOHM,5%,1/8W,AA,TP,1.8X3.2MM	

Loc. No.	Code No.	Description ; Specification	Remark
RM356	2001-000405	R-CARBON:180OHM,5%,1/8W,AA,TP,1.8X3.2MM	
RM357	2001-000780	R-CARBON:470OHM,5%,1/8W,AA,TP,1.8X3.2MM	
RM358	2001-000258	R-CARBON:1.8KOHM,5%,1/8W,AA,TP,1.8X3.2MM	
RM359	2001-000458	R-CARBON:2.2OHM,5%,1/8W,AA,TP,1.8X3.2MM	
RM360	2001-000290	R-CARBON:10KOHM,5%,1/8W,AA,TP,1.8X3.2MM	
RM361	2001-000429	R-CARBON:1KOHM,5%,1/8W,AA,TP,1.8X3.2MM	
RM362	2001-000429	R-CARBON:1KOHM,5%,1/8W,AA,TP,1.8X3.2MM	
RM363	2001-000522	R-CARBON:22KOHM,5%,1/8W,AA,TP,1.8X3.2MM	
RM364	2001-000411	R-CARBON:18KOHM,5%,1/8W,AA,TP,1.8X3.2MM	
RM365	2001-000734	R-CARBON:4.7KOHM,5%,1/8W,AA,TP,1.8X3.2MM	
RM366	2001-000766	R-CARBON:43KOHM,5%,1/8W,AA,TP,1.8X3.2MM	
RM367	2001-000947	R-CARBON:7.5KOHM,5%,1/8W,AA,TP,1.8X3.2MM	
RM369	2001-000800	R-CARBON:5.1KOHM,5%,1/8W,AA,TP,1.8X3.2MM	
RM370	2001-000008	R-CARBON:15KOHM,5%,1/8W,AA,TP,1.8X3.2MM	
RM371	2001-001000	R-CARBON:82KOHM,5%,1/8W,AA,TP,1.8X3.2MM	
RM372	2001-000515	R-CARBON:220OHM,5%,1/8W,AA,TP,1.8X3.2MM	
RM373	2001-000812	R-CARBON:5.6KOHM,5%,1/8W,AA,TP,1.8X3.2MM	
RM377	2001-000273	R-CARBON:100KOHM,5%,1/8W,AA,TP,1.8X3.2MM	
RM378	2001-000995	R-CARBON:820OHM,5%,1/8W,AA,TP,1.8X3.2MM	
RM601	2001-000554	R-CARBON:270OHM,5%,1/8W,AA,TP,1.8X3.2MM	
RM602	2001-000522	R-CARBON:22KOHM,5%,1/8W,AA,TP,1.8X3.2MM	
RM603	2001-000864	R-CARBON:56KOHM,5%,1/8W,AA,TP,1.8X3.2MM	
RM604	2001-000660	R-CARBON:33KOHM,5%,1/8W,AA,TP,1.8X3.2MM	
RM605	2001-000429	R-CARBON:1KOHM,5%,1/8W,AA,TP,1.8X3.2MM	
RM606	2001-000864	R-CARBON:56KOHM,5%,1/8W,AA,TP,1.8X3.2MM	
RM607	2001-000864	R-CARBON:56KOHM,5%,1/8W,AA,TP,1.8X3.2MM	
RM608	2001-000429	R-CARBON:1KOHM,5%,1/8W,AA,TP,1.8X3.2MM	
RM609	2001-000429	R-CARBON:1KOHM,5%,1/8W,AA,TP,1.8X3.2MM	
RM610	2001-000010	R-CARBON:68KOHM,5%,1/8W,AA,TP,1.8X3.2MM	
RM611	2001-000832	R-CARBON:510OHM,5%,1/8W,AA,TP,1.8X3.2MM	
RM612	2001-000290	R-CARBON:10KOHM,5%,1/8W,AA,TP,1.8X3.2MM	
RM613	2001-000429	R-CARBON:1KOHM,5%,1/8W,AA,TP,1.8X3.2MM	
RM614	2001-000290	R-CARBON:10KOHM,5%,1/8W,AA,TP,1.8X3.2MM	
RM615	2001-000290	R-CARBON:10KOHM,5%,1/8W,AA,TP,1.8X3.2MM	
RM616	2001-000660	R-CARBON:33KOHM,5%,1/8W,AA,TP,1.8X3.2MM	
RM618	2001-000786	R-CARBON:47KOHM,5%,1/8W,AA,TP,1.8X3.2MM	
RM624	2001-000429	R-CARBON:1KOHM,5%,1/8W,AA,TP,1.8X3.2MM	
RM626	2001-000429	R-CARBON:1KOHM,5%,1/8W,AA,TP,1.8X3.2MM	
RM628	2001-000429	R-CARBON:1KOHM,5%,1/8W,AA,TP,1.8X3.2MM	
RM629	2001-000429	R-CARBON:1KOHM,5%,1/8W,AA,TP,1.8X3.2MM	
RM630	2003-002129	R-METAL OXIDE(S):3.9ohm,5%,2W,AF,TP,3.9x10mm	
RM634	2001-000734	R-CARBON:4.7KOHM,5%,1/8W,AA,TP,1.8X3.2MM	
RM635	2001-000734	R-CARBON:4.7KOHM,5%,1/8W,AA,TP,1.8X3.2MM	
RM636	2001-000734	R-CARBON:4.7KOHM,5%,1/8W,AA,TP,1.8X3.2MM	
RM638	2001-000429	R-CARBON:1KOHM,5%,1/8W,AA,TP,1.8X3.2MM	
RM639	2001-000290	R-CARBON:10KOHM,5%,1/8W,AA,TP,1.8X3.2MM	
RM640	2001-000522	R-CARBON:22KOHM,5%,1/8W,AA,TP,1.8X3.2MM	
RM641	2001-000118	R-CARBON(S):180OHM,5%,1/2W,AA,TP,2.4x6.4MM	
RM642	2001-000633	R-CARBON:30KOHM,5%,1/8W,AA,TP,1.8X3.2MM	
RM643	2001-000429	R-CARBON:1KOHM,5%,1/8W,AA,TP,1.8X3.2MM	
RM644	2001-000010	R-CARBON:68KOHM,5%,1/8W,AA,TP,1.8X3.2MM	
RM647	2001-000429	R-CARBON:1KOHM,5%,1/8W,AA,TP,1.8X3.2MM	
RM648	2001-000429	R-CARBON:1KOHM,5%,1/8W,AA,TP,1.8X3.2MM	
RM649	2001-000429	R-CARBON:1KOHM,5%,1/8W,AA,TP,1.8X3.2MM	
RM650	2001-000429	R-CARBON:1KOHM,5%,1/8W,AA,TP,1.8X3.2MM	
RM651	2001-000429	R-CARBON:1KOHM,5%,1/8W,AA,TP,1.8X3.2MM	
RM652	2001-000429	R-CARBON:1KOHM,5%,1/8W,AA,TP,1.8X3.2MM	
RM653	2001-000429	R-CARBON:1KOHM,5%,1/8W,AA,TP,1.8X3.2MM	
RM654	2001-000005	R-CARBON:390OHM,5%,1/8W,AA,TP,1.8X3.2MM	
RM655	2001-000005	R-CARBON:390OHM,5%,1/8W,AA,TP,1.8X3.2MM	
RM657	2001-000429	R-CARBON:1KOHM,5%,1/8W,AA,TP,1.8X3.2MM	
RM660	2001-000522	R-CARBON:22KOHM,5%,1/8W,AA,TP,1.8X3.2MM	
RM661	2001-000554	R-CARBON:270OHM,5%,1/8W,AA,TP,1.8X3.2MM	
RM663	2001-000429	R-CARBON:1KOHM,5%,1/8W,AA,TP,1.8X3.2MM	
RM664	2001-000429	R-CARBON:1KOHM,5%,1/8W,AA,TP,1.8X3.2MM	
RM665	2001-000429	R-CARBON:1KOHM,5%,1/8W,AA,TP,1.8X3.2MM	
RM666	2001-000429	R-CARBON:1KOHM,5%,1/8W,AA,TP,1.8X3.2MM	
RM667	2001-000281	R-CARBON:100OHM,5%,1/8W,AA,TP,1.8X3.2MM	
RM668	2001-000281	R-CARBON:100OHM,5%,1/8W,AA,TP,1.8X3.2MM	
RM669	2001-000539	R-CARBON:24KOHM,5%,1/8W,AA,TP,1.8X3.2MM	
RM670	2001-000009	R-CARBON:20KOHM,5%,1/8W,AA,TP,1.8X3.2MM	
RM671	2001-000331	R-CARBON:12KOHM,5%,1/8W,AA,TP,1.8X3.2MM	
RM674	2001-000429	R-CARBON:1KOHM,5%,1/8W,AA,TP,1.8X3.2MM	
RM678	2001-000429	R-CARBON:1KOHM,5%,1/8W,AA,TP,1.8X3.2MM	
RM679	2001-000429	R-CARBON:1KOHM,5%,1/8W,AA,TP,1.8X3.2MM	
RM680	2001-000429	R-CARBON:1KOHM,5%,1/8W,AA,TP,1.8X3.2MM	
RM681	2001-000429	R-CARBON:1KOHM,5%,1/8W,AA,TP,1.8X3.2MM	

Loc. No.	Code No.	Description ; Specification	Remark
RM682	2001-000429	R-CARBON:1KOHM,5%,1/8W,AA,TP,1.8X3.2MM	
RM683	2001-000429	R-CARBON:1KOHM,5%,1/8W,AA,TP,1.8X3.2MM	
RM684	2001-000429	R-CARBON:1KOHM,5%,1/8W,AA,TP,1.8X3.2MM	
RM685	2001-000429	R-CARBON:1KOHM,5%,1/8W,AA,TP,1.8X3.2MM	
RM686	2001-000429	R-CARBON:1KOHM,5%,1/8W,AA,TP,1.8X3.2MM	
RM687	2001-000429	R-CARBON:1KOHM,5%,1/8W,AA,TP,1.8X3.2MM	
RM688	2001-000429	R-CARBON:1KOHM,5%,1/8W,AA,TP,1.8X3.2MM	
RM689	2001-000429	R-CARBON:1KOHM,5%,1/8W,AA,TP,1.8X3.2MM	
RM690	2001-000429	R-CARBON:1KOHM,5%,1/8W,AA,TP,1.8X3.2MM	
RM691	2001-000429	R-CARBON:1KOHM,5%,1/8W,AA,TP,1.8X3.2MM	
RM692	2001-000429	R-CARBON:1KOHM,5%,1/8W,AA,TP,1.8X3.2MM	
RM693	2001-000429	R-CARBON:1KOHM,5%,1/8W,AA,TP,1.8X3.2MM	
RM694	2001-000429	R-CARBON:1KOHM,5%,1/8W,AA,TP,1.8X3.2MM	
RM696	2001-000290	R-CARBON:10KOHM,5%,1/8W,AA,TP,1.8X3.2MM	
RM697	2001-000290	R-CARBON:10KOHM,5%,1/8W,AA,TP,1.8X3.2MM	
RM698	2001-000290	R-CARBON:10KOHM,5%,1/8W,AA,TP,1.8X3.2MM	
RM699	2001-000290	R-CARBON:10KOHM,5%,1/8W,AA,TP,1.8X3.2MM	
SM601	AA91-60319A	ASSY-HOLDER,SENSOR:-ABS,HB,BLK,TR LED,TS-DECK	
SM602	AA91-60319A	ASSY-HOLDER,SENSOR:-ABS,HB,BLK,TR LED,TS-DECK	
SWM610	AA34-20001A	SWITCH-MODE:1,25x14.6x29.8mm,BK,DC5V	
SWM611	AA34-40001A	SWITCH-REC.:1EA,37.5x14.4mm,BK,DC5V	
SWM612	3404-000244	SWITCH-TACT:15V,20mA,90-170gf,7.5x7mm,SPST	
VRM601	2103-000669	VR-SEMI:10Kohm,25%,1/5W,TOP	
XTM301	2801-000277	CRYSTAL-UNIT:4.433619MHz,8ppm,28-AAAM,S,100o	
XTM601	2801-003750	CRYSTAL-UNIT:8MHz,30PPM,28-AAA,22PF,800OHM,TP	
XTM602	2801-003224	CRYSTAL-UNIT:32.768KHz,20ppm,28-AAA,12.5pF	
ZDM101	0403-000355	DIODE-ZENER:UZ5.1BSB,5.1V,4.97-5.18V,500mW	
ZDM102	0403-000563	DIODE-ZENER:MT29.1B,9.1V,8.57-9.01V,500mW	

### ASSY-PCB,IF

*	AA95-00090A	ASSY-PCB,IF:-TB20A5/TX20A5,C15A,PAL-B/G,-,-	
C101	2202-002037	C-CERAMIC,MLC-AXIAL:100nF,80-20%,50V,Y5V,TP,2.2x3.	
C102	2401-000603	C-AL:1uF,20%,50V,GP,TP,5x11,5	
C103	2202-000797	C-CERAMIC,MLC-AXIAL:10NF,30%,16V,Y5S,TP,3.5X1.9MM,-	
C104	2401-000302	C-AL:100uF,20%,25V,GP,TP,6.3x11,5	
C106	2301-000224	C-FILM,PEF:22nF,5%,50V,TP,7.4x3.9x13mm,5m	
C108	2401-001333	C-AL:470nF,20%,50V,GP,TP,5x11,5	
C109	2401-000660	C-AL:2.2uF,20%,50V,GP,TP,5x11,5	
C110	2401-000962	C-AL:22uF,20%,50V,GP,TP,5x11,5	
C112	2301-000175	C-FILM,PEF:15nF,5%,50V,TP,7.1x3.5x13mm,5m	
C113	2305-000665	C-FILM,MPEF:100nF,5%,63V,TP,7.5x4.0x5.0mm,	
CN02	3711-002708	CONNECTOR-HEADER:NOWALL,10P,1R,2.5mm,ANGLE,SN	
F101	2903-000184	FILTER-CERAMIC:BP5,5MHz,+60KHz,6dB,-,TP-	
F103	2903-000181	FILTER-CERAMIC:TR,5.5MHz,-,-,TP,TPS5.5MB-TF	
IC101	1204-001435	IC-IF SYSTEM:LA7565B,DIP,24P,300MIL,PLASTIC	
L101	2701-000215	INDUCTOR-AXIAL:8.2uH,10%,2.5x3.4mm	
L102	AA26-10006L	TRANS-IF:-7MG,VIF,-,7mm,39pF,38.9MHz,S	
L103	2701-000171	INDUCTOR-AXIAL:330nH,10%,2.5x3.4mm	
Q101	0501-000389	TR-SMALL SIGNAL:KSC815,NPN,400mW,TO-92,TP,120-	
R101	2001-000786	R-CARBON:47KOHM,5%,1/8W,AA,TP,1.8X3.2MM	
R102	2001-000005	R-CARBON:390OHM,5%,1/8W,AA,TP,1.8X3.2MM	
R104	2001-000761	R-CARBON:430OHM,5%,1/8W,AA,TP,1.8X3.2MM	
R105	2001-000281	R-CARBON:100OHM,5%,1/8W,AA,TP,1.8X3.2MM	
R107	2001-000563	R-CARBON:27KOHM,5%,1/8W,AA,TP,1.8X3.2MM	
R109	2001-000009	R-CARBON:20KOHM,5%,1/8W,AA,TP,1.8X3.2MM	
R113	2001-000411	R-CARBON:18KOHM,5%,1/8W,AA,TP,1.8X3.2MM	
R115	2001-000812	R-CARBON:5.6KOHM,5%,1/8W,AA,TP,1.8X3.2MM	
R120	2001-000837	R-CARBON:51KOHM,5%,1/8W,AA,TP,1.8X3.2MM	
R121	2001-000679	R-CARBON:36KOHM,5%,1/8W,AA,TP,1.8X3.2MM	
R127	2001-000005	R-CARBON:390OHM,5%,1/8W,AA,TP,1.8X3.2MM	
R128	2001-000331	R-CARBON:12KOHM,5%,1/8W,AA,TP,1.8X3.2MM	
R129	2001-000008	R-CARBON:15KOHM,5%,1/8W,AA,TP,1.8X3.2MM	
SFK01	2904-001070	FILTER-SAW AV:38.9MHz,SIP5K,TP,14.5dB,PAL-B/	

### ASSY-PCB,CONTROL

*	AA95-00092A	ASSY-PCB,CONTROL:DP,C15A,14/20,ALL	
CM701	2202-002037	C-CERAMIC,MLC-AXIAL:100nF,80-20%,50V,Y5V,TP,2.2x3.	
CM702	2401-002291	C-AL:47uF,20%,16V,GP,TP,6.3x5,5	
CN701	AA39-20144B	LEAD CONNECTOR-ASSY:-,35023-0013,51004-1300,13P,300	
DM701	0401-000005	DIODE-SWITCHING:1N4148,75V,200MA,DO-35,TP	
DZ701	0403-000296	DIODE-ZENER:MT25.6B,5.6V,5.45-5.73V,500mW	

Loc. No.	Code No.	Description ; Specification	Remark
DZ702	0403-000296	DIODE-ZENER:MTZ5.6B,5.6V,5.45-5.73V,500mW,	
DZ703	0403-000296	DIODE-ZENER:MTZ5.6B,5.6V,5.45-5.73V,500mW,	
DZ704	0403-000296	DIODE-ZENER:MTZ5.6B,5.6V,5.45-5.73V,500mW,	
DZ705	0403-000296	DIODE-ZENER:MTZ5.6B,5.6V,5.45-5.73V,500mW,	
LDM701	0601-000385	LED:ROUND,RED,3mm,700nm	
LDM702	0601-000385	LED:ROUND,RED,3mm,700nm	
LDM703	0601-000385	LED:ROUND,RED,3mm,700nm	
QM701	0504-000118	TR-DIGITAL;KSR1003,NPN,300MW,22K/22K,TO-92,TP	
QM702	0504-000118	TR-DIGITAL;KSR1003,NPN,300MW,22K/22K,TO-92,TP	
QM703	0504-000118	TR-DIGITAL;KSR1003,NPN,300MW,22K/22K,TO-92,TP	
REM701	AA59-60002B	MODULE-REMOCON;-;ORC-50HF,38KHz,940mm,MESH,H,	
RM701	2001-000857	R-CARBON:560OHM,5%,1/8W,AA,TP,1.8X3.2MM	
RM702	2001-000857	R-CARBON:560OHM,5%,1/8W,AA,TP,1.8X3.2MM	
RM703	2001-000857	R-CARBON:560OHM,5%,1/8W,AA,TP,1.8X3.2MM	
RM704	2001-000734	R-CARBON:4.7KOHM,5%,1/8W,AA,TP,1.8X3.2MM	
RM705	2001-000429	R-CARBON:1KOHM,5%,1/8W,AA,TP,1.8X3.2MM	
RM706	2001-000429	R-CARBON:1KOHM,5%,1/8W,AA,TP,1.8X3.2MM	
RM707	2001-000429	R-CARBON:1KOHM,5%,1/8W,AA,TP,1.8X3.2MM	
SWM701	3404-001006	SWITCH-TACT:12V,50mA,160gf,6x6mm,SPST	
SWM702	3404-001006	SWITCH-TACT:12V,50mA,160gf,6x6mm,SPST	
SWM703	3404-001006	SWITCH-TACT:12V,50mA,160gf,6x6mm,SPST	
SWM704	3404-001006	SWITCH-TACT:12V,50mA,160gf,6x6mm,SPST	
SWM705	3404-001006	SWITCH-TACT:12V,50mA,160gf,6x6mm,SPST	
SWM706	3404-001006	SWITCH-TACT:12V,50mA,160gf,6x6mm,SPST	
SWM707	3404-001006	SWITCH-TACT:12V,50mA,160gf,6x6mm,SPST	
SWM708	3404-001006	SWITCH-TACT:12V,50mA,160gf,6x6mm,SPST	
SWM709	3404-001006	SWITCH-TACT:12V,50mA,160gf,6x6mm,SPST	
SWM710	3404-001006	SWITCH-TACT:12V,50mA,160gf,6x6mm,SPST	

**ASSY-PCB,MASTER**

- \* AA95-00093A ASSY-PCB,MASTER-DP,-,C15A,PAL,-,ALL
- 3403-000179 SWITCH-PUSH:250V,5A,DPST,-,JPW-2104B
- 6001-000057 SCREW-MACHINE;RH,+;M3,L6,ZPC(BLK),SWRCH18A,F
- AA39-20041B LEAD-CONNECTOR,ASSY;-;YFH800-02,S,2P,300,1617#22
- AA61-10320A BRACKET-MASTER;-;T3350,SECC,T1.0,-,-,-

**ASSY-PCB,CRT**

- \* AA95-20011A ASSY-PCB,CRT;-;C15A,20,21,EC,-
- C502 2301-000213 C-FILM,PEF;220nF,5%,250V,TP,21.5x11,7,5
- C503 2201-002063 C-CERAMIC,DISC;10nF,+80-20%,3KV,Y5V,TP,16x5,7
- C504 2401-001232 C-AL;4.7uF,20%,250V,GP,TP,10x12,5,5
- C506 2401-000430 C-AL;10uF,20%,250V,GP,TP,10x16mm,5m
- C510 2201-000471 C-CERAMIC,DISC;.33NF,10%,50V,Y5P,TP,4X3MM,5
- CN503A AA39-20030B LEAD-CONNECTOR,ASSY;-;67096-008,S,8P,400,1007#26
- CN503B 3711-002647 CONNECTOR-HEADER;BOX,8P,1R,2.5mm,STRAIGHT,SN
- D501 0402-000216 DIODE-RECTIFIER;ERC24-06,600V,1.0A,DO-204
- D502 0402-000546 DIODE-RECTIFIER;TVR10G,400V,1.0A,DO-41,TP
- D503 0402-000546 DIODE-RECTIFIER;TVR10G,400V,1.0A,DO-41,TP
- D504 0402-000546 DIODE-RECTIFIER;TVR10G,400V,1.0A,DO-41,TP
- DZ501 0403-000563 DIODE-ZENER:MTZ9.1B,9.1V,8.57-9.01V,500mW,
- DZ502 0403-000563 DIODE-ZENER:MTZ9.1B,9.1V,8.57-9.01V,500mW,
- DZ503 0403-000563 DIODE-ZENER:MTZ9.1B,9.1V,8.57-9.01V,500mW,
- DZ504 0403-000563 DIODE-ZENER:MTZ9.1B,9.1V,8.57-9.01V,500mW,
- GT502A AA39-20010D LEAD-CONNECTOR,ASSY;-;YFH800-01,S,1P,400,1617#22
- IC501 1201-001159 IC-VIDEO AMP;6107,ZIP;9P,300MIL,SINGLE,-,PL
- R501H 2002-001009 R-COMPOSITION;2.7Kohm,10%,1/2W,AA,TP,3.7X9.0
- R502H 2002-001009 R-COMPOSITION;2.7Kohm,10%,1/2W,AA,TP,3.7X9.0
- R503 2002-001009 R-COMPOSITION;2.7Kohm,10%,1/2W,AA,TP,3.7X9.0
- R504 2001-001062 R-CARBON(S);10MOHM,5%,1/2W,AA,TP,2.4X6.4MM
- R505 2008-001015 R-FUSIBLE(S);1.5ohm,5%,2W,AF,TP,3.9x10mm
- R510 2001-000281 R-CARBON:100OHM,5%,1/8W,AA,TP,1.8X3.2MM
- R511 2001-000281 R-CARBON:100OHM,5%,1/8W,AA,TP,1.8X3.2MM
- R512 2001-000281 R-CARBON:100OHM,5%,1/8W,AA,TP,1.8X3.2MM
- V999 3704-001105 SOCKET-CRT;11P,20PI,26.5PI,NI,-

**ASSY-PCB,A/V**

- \* AA95-40012B ASSY-PCB,A/V;DP,TF502,C15A,PAL,230V,14-21'
- CNC701A AA39-20069D LEAD-CONNECTOR,ASSY;-;YBNH025-05,67096-005,5P,300,
- CNC701B AA39-20070C LEAD-CONNECTOR,ASSY;-;YBNH025-07,67096-007,7P,400,

Loc. No.	Code No.	Description ; Specification	Remark
CY702	2202-000121	C-CERAMIC,MLC-AXIAL;100pF,10%,50V,Y5P,TP,1.9x3.5,-	
JA01	3722-001343	JACK-RCA;1P,3.4MM,NI,WHIT,-	
JA02	3722-001342	JACK-RCA;1P,3.4MM,NI,YEL,-	
JA03	3722-000145	JACK-PHONE;1P,3.6mm,MBAG,BLK,-	
LY701	2701-000114	INDUCTOR-AXIAL;10uH,10%,2.5x3.4mm	
LY702	2701-000114	INDUCTOR-AXIAL;10uH,10%,2.5x3.4mm	
RY701	2001-001187	R-CARBON(S);75OHM,5%,1/2W,AA,TP,2.4X6.4MM	
RY702	2001-001187	R-CARBON(S);75OHM,5%,1/2W,AA,TP,2.4X6.4MM	

**ASSY-SPEAKER**

- 3001-001037 SPEAKER;5W,8ohm,89dB,180Hz
- AA39-20501C LEAD CONNECTOR-ASSY;-;67096-003,REC,3(2)P,700mm,10

**ASSY-CRT**

- △ CRT-COLOR ; LOCAL (SESA)

**ASSY-POWER,CORD**

- △ POWER-CORD ; LOACL (SESA)

**REMOCON**

- \* AA59-00006J REMOCON;-;TM48,SSOM728EU,43,L/GRAY,SS,EX,-,-

**ASSY-ACCESSORY**

- AA68-00128A MANUAL-USERS ; LOCAL (SESA)

---

## 9. Block Diagrams

---

### 9-1 C15A Video Block Diagram

---

#### 9-1-1 Notes

The TV's 1st and 2nd tuners (and VCR module) are "multi-system." compatible:  
IC201 (TDA8842/8841) is the video, chroma, and deflection (VCD) IC .

#### 9-1-1(A) TAPE PLAYBACK (REGARDLESS OF ORIGINAL RECORDING SYSTEM)

If the output PB signal of micom pin 6 is high, the PB signal outputs from module deck 2, passes through IC 702 pins 2 and 3 and out to another VCR . The output signal of IC701 pin 1 (pin 15) outputs from IC201 pin 17 .

#### 9-1-1(B) VIEWING NORMAL CHANNEL WHILE RECORDING A SCRAMBLED CHANNEL:

The output CVBS (Composite Video Signal) of the 2nd IF outputs to IC702 pin 3 when the micom's pin 7 V/T/H (VCR tuner high) is high . The decoded signal goes to IC701 pin 2, where it is fed to IC 701 pin 4 (high output of micom's pin 8— AV/Tuner), and out to VCR pin 4 (module deck) for recording.

#### 9-1-1(C) VIEWING A SCRAMBLED CHANNEL WHILE RECORDING AN UNSCRAMBLED CHANNEL.

The output CVBS of the 2nd IF is fed from IC701 pin 5 to IC701 pin 4 (low output of micom pin 8—AV/tuner). Then it goes to the module deck pin 4 for recording.

The scrambled signal (CVBS) is fed to IC702 pin 1 through the 1st IF, and then to IC702 pin 3 (micom's pin 7, V/T/H registers low). Then it goes to the decoder input. The descrambled signal goes to IC701 pins 2 and 15 (PH high output of micom's pin 6), and then to IC201 pin 17, where it outputs as RGB.

#### 9-1-1(D) SYNCHRONOUS RECORDING:

The viewer sees the signal from the 1st tuner , while the signal from the second tuner is recorded. Audio processing for the French system type is shown in the table.

## 9-2 C15A Video Block Diagram (Continued)

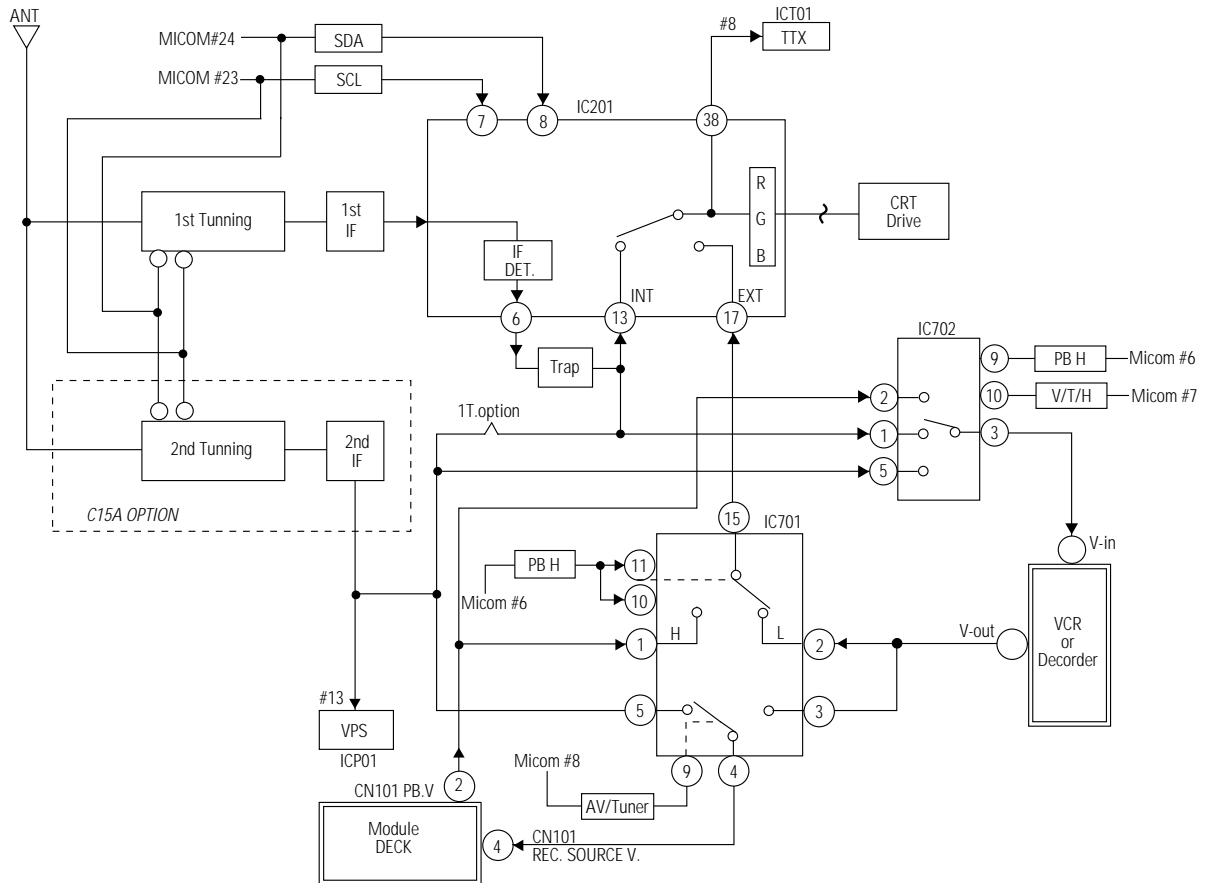

### Micom Pin Function

PIN NO.	PIN NAME	FUNCTION												
6	PB H	High Output : Playback signal is monitored. The PB signal is output at scart.												
7	V/T/H	High Output : The second tuner signal is output at scart.												
8	AV/TUNER	High Output : AV signal is recorded. Low output : TUNER signal is recorded.												
56, 57	S-L H FRA H	<table border="1"> <thead> <tr> <th>S \ Port</th> <th>S-L H</th> <th>FRA H</th> </tr> </thead> <tbody> <tr> <td>PAL/SEC</td> <td>L</td> <td>L</td> </tr> <tr> <td>FRANCE-L</td> <td>L</td> <td>H</td> </tr> <tr> <td>FRANCE-L'</td> <td>H</td> <td>L</td> </tr> </tbody> </table> <p>Ⓐ C. SYSTEM : PAL/SEC ARE AUTO mode, and France is SECAM mode.</p>	S \ Port	S-L H	FRA H	PAL/SEC	L	L	FRANCE-L	L	H	FRANCE-L'	H	L
S \ Port	S-L H	FRA H												
PAL/SEC	L	L												
FRANCE-L	L	H												
FRANCE-L'	H	L												
23,24	SDA,SCL	Extra control signals are all controlled by the I <sup>2</sup> C bus. Select INT/EXT FRENCH system modulation												

### 9-3 C15A Audio Block Diagram (Continued)

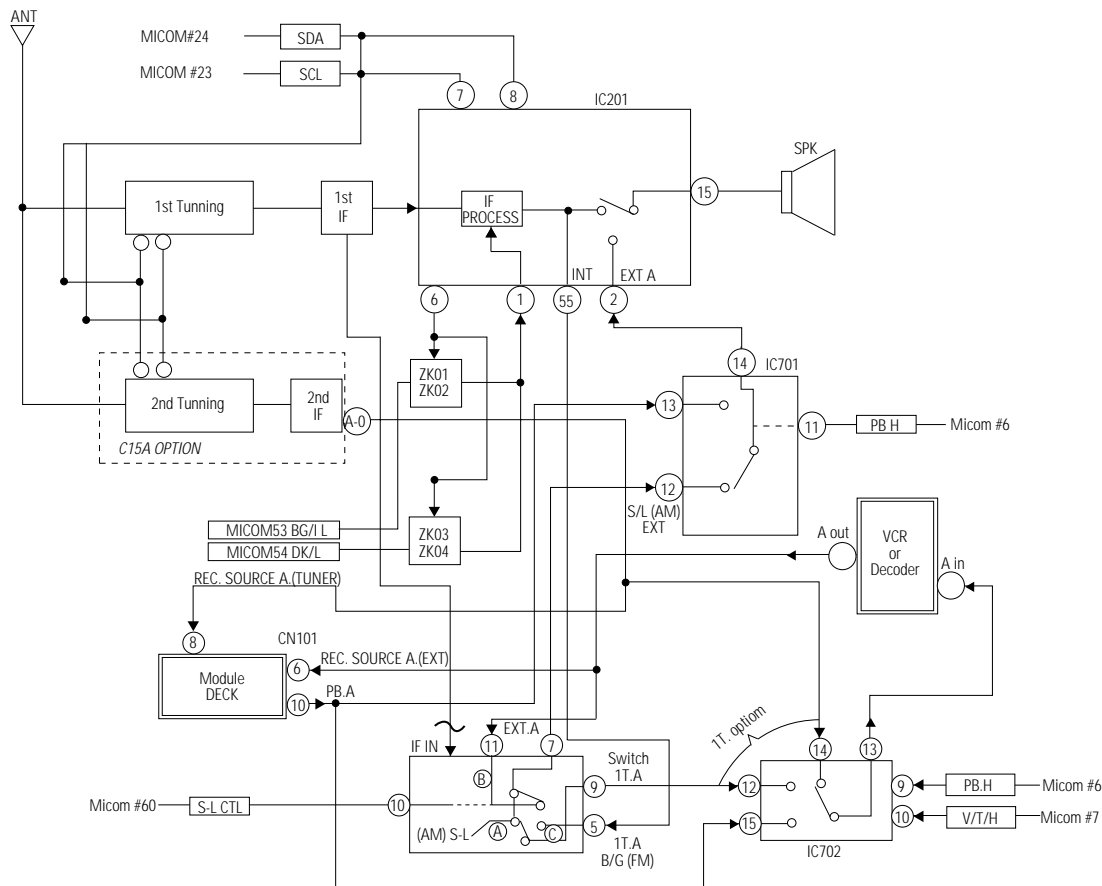

#### Micom Pin Function

PIN NO.	PIN NAME	FUNCTION															
6	PB H	High output : PB audio is monitored. The PB audio is output at scart.															
7	V/T/H	High output : The second tuner audio is output at a scart.															
8	AV/TUNER	High output : AV audio is recorded. Low output : TUNER audio is recorded.															
60	S-L CTL ① :S-L(AM) ② : B/G (FM) ③ :EXT	① 1.8 ~ 2.6V : In TV FM Mode, connect pin 7 to A and pin 9 to C. ② 4.1 ~ 4.9V : In TV AM Mode, connect pin 7 to A and pin 9 to A. ③ 6.4 ~ 7.2V : In AV-AM Mode, connect pin 7 to B and pin 9 to A. ④ More than 7.3V : In AV-FM Mode, connect pin 7 to B and pin 9 to C.															
53,54	SDA, SCL BG/I L DK/L	<table border="1"> <thead> <tr> <th>Port \ S</th> <th>B/G</th> <th>D/K</th> </tr> </thead> <tbody> <tr> <td>AUTO</td> <td>L</td> <td>L</td> </tr> <tr> <td>BG</td> <td>L</td> <td>H</td> </tr> <tr> <td>DK</td> <td>H</td> <td>L</td> </tr> <tr> <td>I</td> <td>L</td> <td>H</td> </tr> </tbody> </table>	Port \ S	B/G	D/K	AUTO	L	L	BG	L	H	DK	H	L	I	L	H
Port \ S	B/G	D/K															
AUTO	L	L															
BG	L	H															
DK	H	L															
I	L	H															

# 10. PCB Layout

## 10-1 Video Main

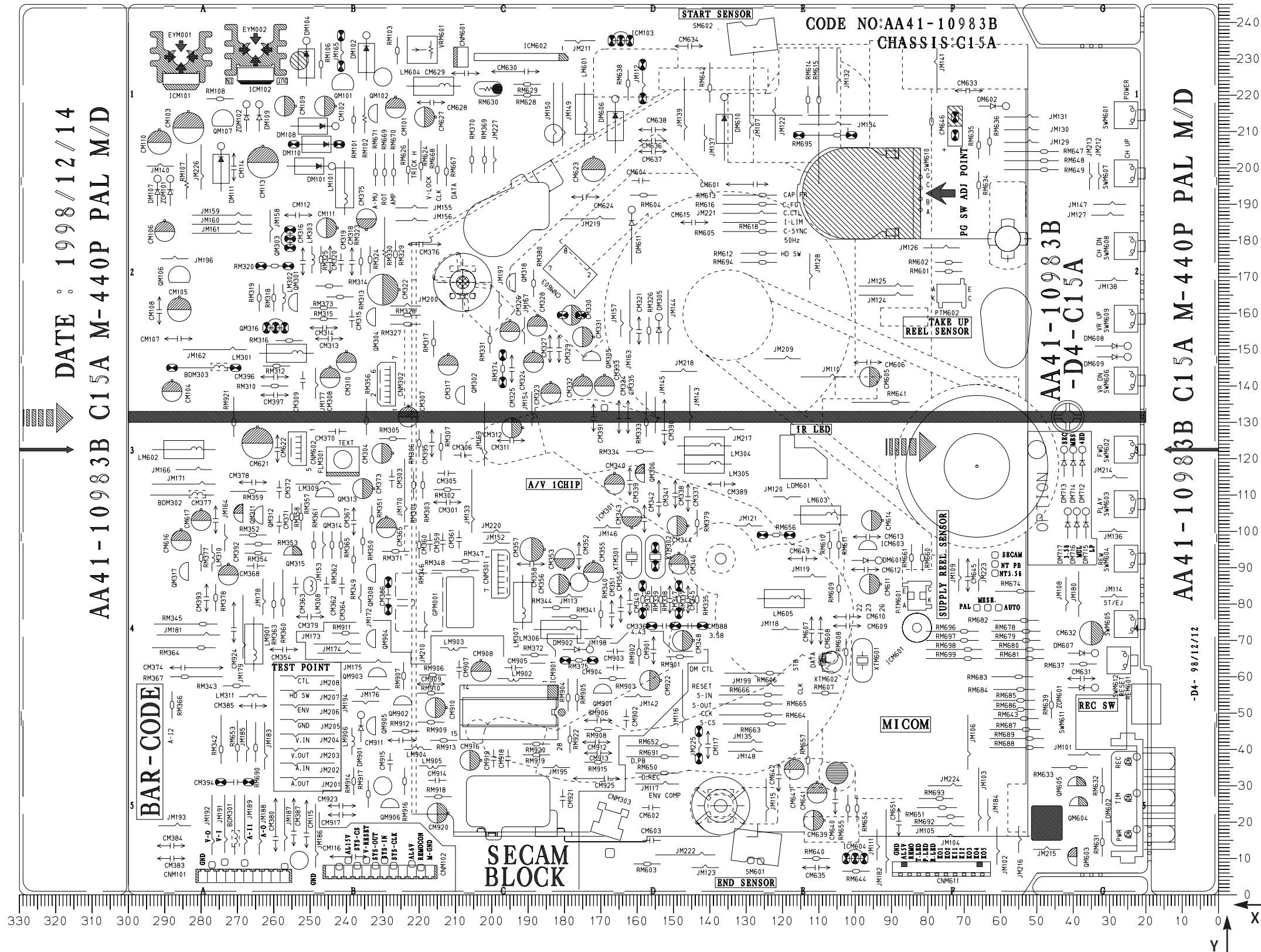

Loc. No.	X	Y	Loc. No.	X	Y
<b>DIODE</b>					
DM101	244	200	QM603	39	13
DM102	234	236	QM604	36	24
DM104	251	235	QM605	36	30
DM107	292	197	QM901	167	55
DM108	243	211	QM902	222	52
DM109	264	217	QM903	229	60
DM110	242	206	QM904	232	73
DM111	274	206	QM905	232	49
DM305	154	159	QM906	225	24
DM601	93	92			
DM602	58	217			
DM606	166	219			
DM607	34	66			
DM608	25	151			
DM609	25	148			
DM610	136	219			
DM611	161	188			
DM712	37	122			
DM713	42	122			
DM714	40	122			
DM715	36	105			
DM716	39	105			
DM717	41	105			
DM901	236	49			
DM902	173	67			
<b>IC</b>					
FLM301	241	119			
ICM101	285	230			
ICM102	265	232			
ICM103	162	235			
ICM301	183	112			
ICM601	87	45			
ICM602	180	230			
ICM603	94	95			
ICM604	97	10			
ICM901	183	44			
<b>TRANSISTOR</b>					
QM101	238	223			
QM102	231	217			
QM106	283	170			
QM107	271	213			
QM301	253	165			
QM302	207	140			
QM303	255	183			
QM304	232	161			
QM305	170	147			
QM306	158	118			
QM308	232	91			
QM311	268	107			
QM312	263	107			
QM313	243	109			
QM314	242	104			
QM315	252	93			
QM316	257	156			
QM317	283	91			
QM318	193	171			

10-2 TV Main

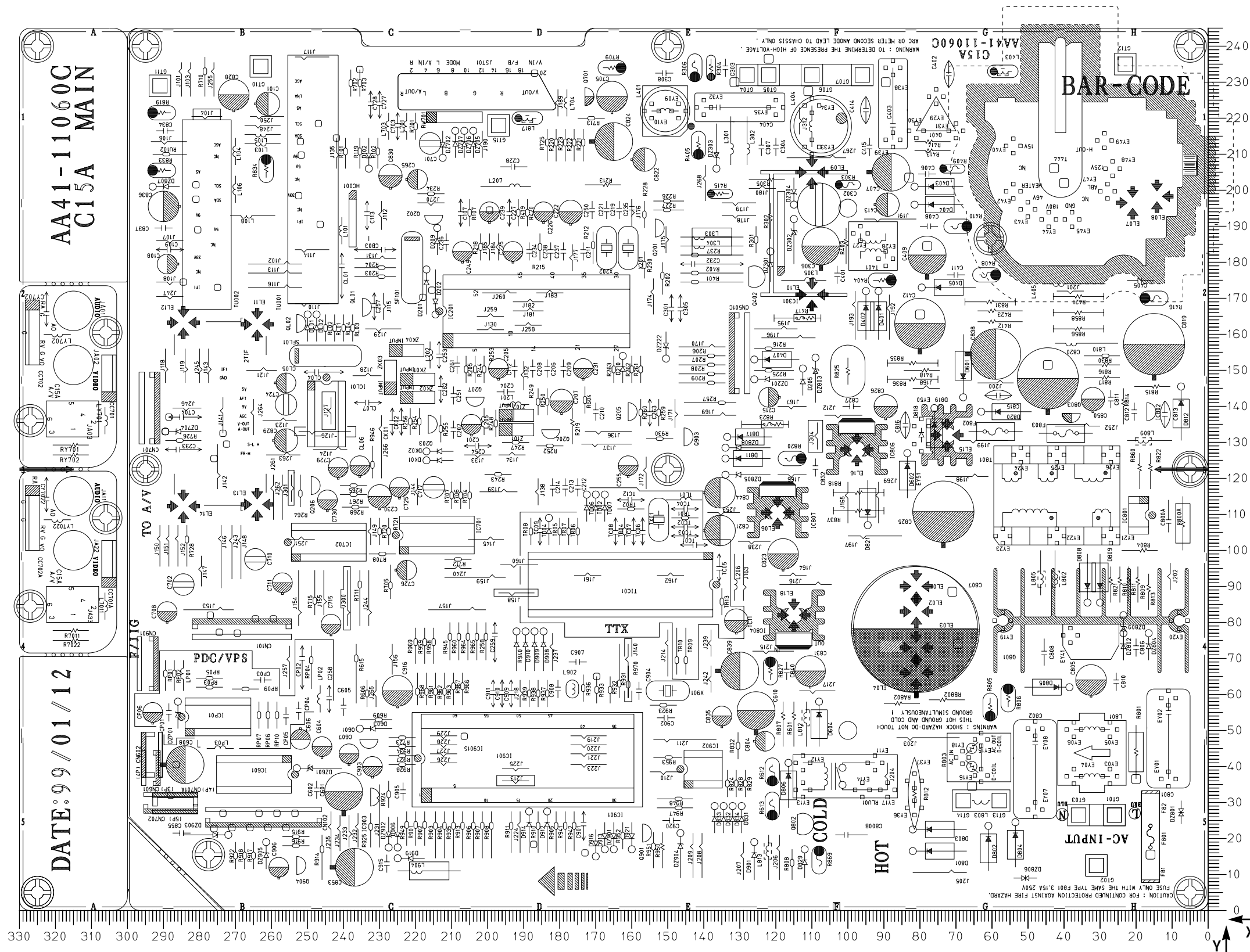

Loc. No.	X	Y	Loc. No.	X	Y
<b>DIODE</b>					
D102	233	206	DZ705	204	216
D201	217	178	DZ706	206	216
D202	214	165	DZ707	209	216
D205	112	150	DZ801	7	23
D209	214	189	DZ802	23	77
D210	162	154	DZ803	109	153
D401	91	172	DZ804	16	77
D402	95	172	DZ805	134	121
D403	81	201	DZ806	54	9
D404	81	196	DZ807	293	201
D405	79	173	DZ808	134	128
D407	126	153	DZ809	23	82
D601	68	142	DZ901	165	17
D602	83	127	DZ902	227	17
D603	235	50	DZ903	272	21
D604	108	58	DZ904	146	21
D801	82	16	DZ905	261	19
D802	61	23	DZP01	286	58
<b>IC</b>					
D803	82	22	HC001	237	198
D804	53	24	IC201	210	174
D805	38	62	IC301	110	171
D806	116	41	IC601	256	33
D808	33	85	IC701	223	108
D809	30	85	IC702	253	106
D811	134	125	IC801	18	105
D812	7	145	IC802	17	136
D817	133	131	IC804	115	82
D818	72	132	IC806	97	128
D819	76	139	IC807	119	110
D820	63	138	IC901	216	52
D821	94	107	IC901S	221	52
D829	112	17	IC902	144	43
D831	129	29	IC903	232	29
D832	134	29	ICL01	240	145
D833	137	29	ICP01	282	58
D834	132	29	<b>TRANSISTOR</b>		
D901	126	19	Q201	153	187
D906	225	17	Q202	217	193
D908	184	77	Q203	216	132
D909	187	77	Q204	185	133
D910	189	77	Q205	161	136
D912	183	27	Q206	249	115
D913	167	17	Q207	206	142
D914	188	27	Q401	70	216
D916	170	15	Q402	126	173
D919	225	14	Q601	235	47
D921	160	17	Q701	173	223
DK01	217	125	Q801	8	80
DK02	217	127	Q802	112	21
DL01	250	165	Q803	40	138
DL02	247	165	Q901	157	19
DZ201	126	147	DZ302	115	192
DZ222	150	153	DZ303	136	206
DZ301	121	183	DZ304	115	196
DZ302	115	192	DZ601	253	39
DZ303	136	206	DZ702	212	209
DZ304	115	196	DZ704	289	133
DZ601	253	39			
DZ702	212	209			
DZ704	289	133			



# 11. Wiring Diagram

## 11-1 C15A Wiring Diagram

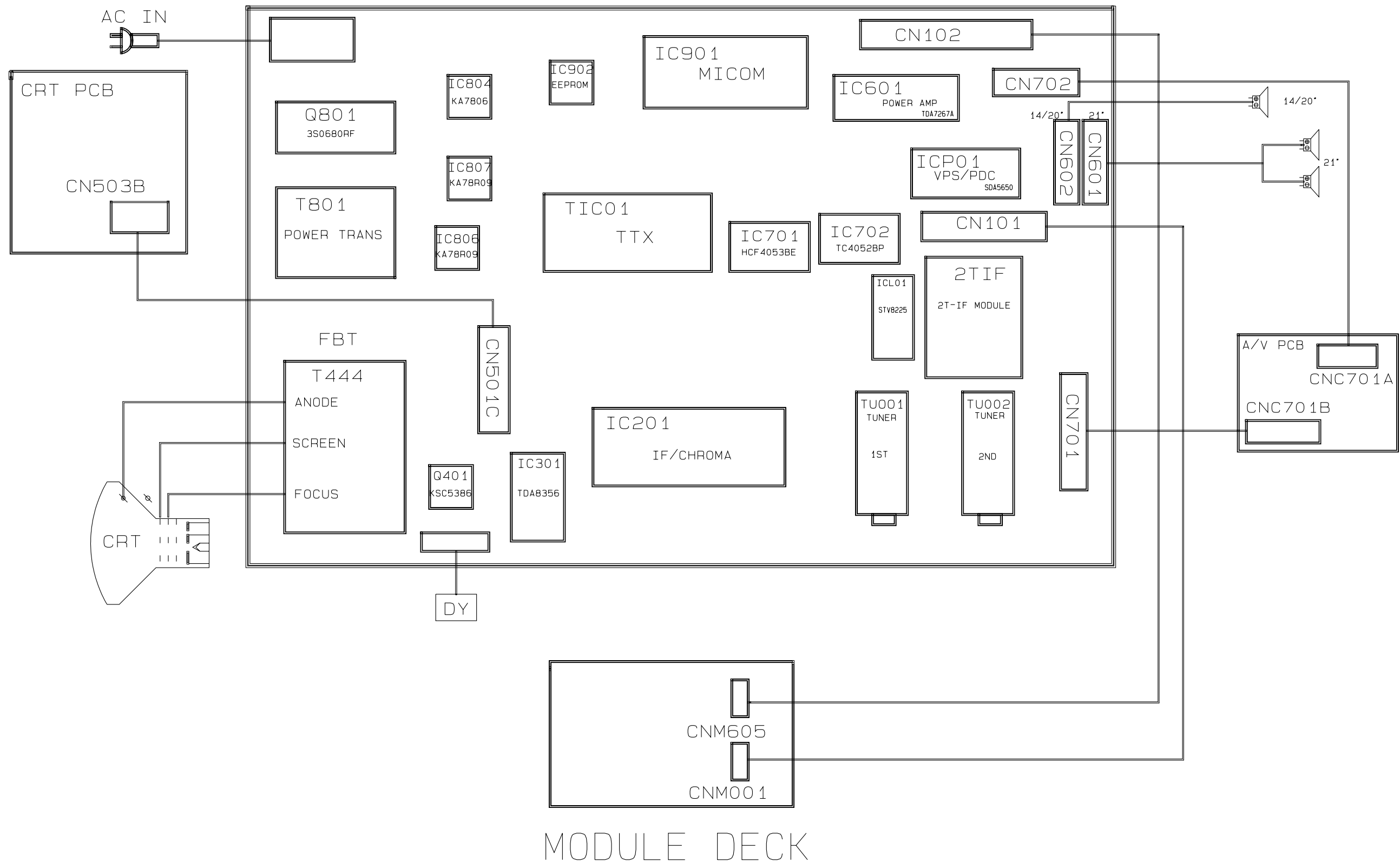

11-2 C15A Wiring Diagram

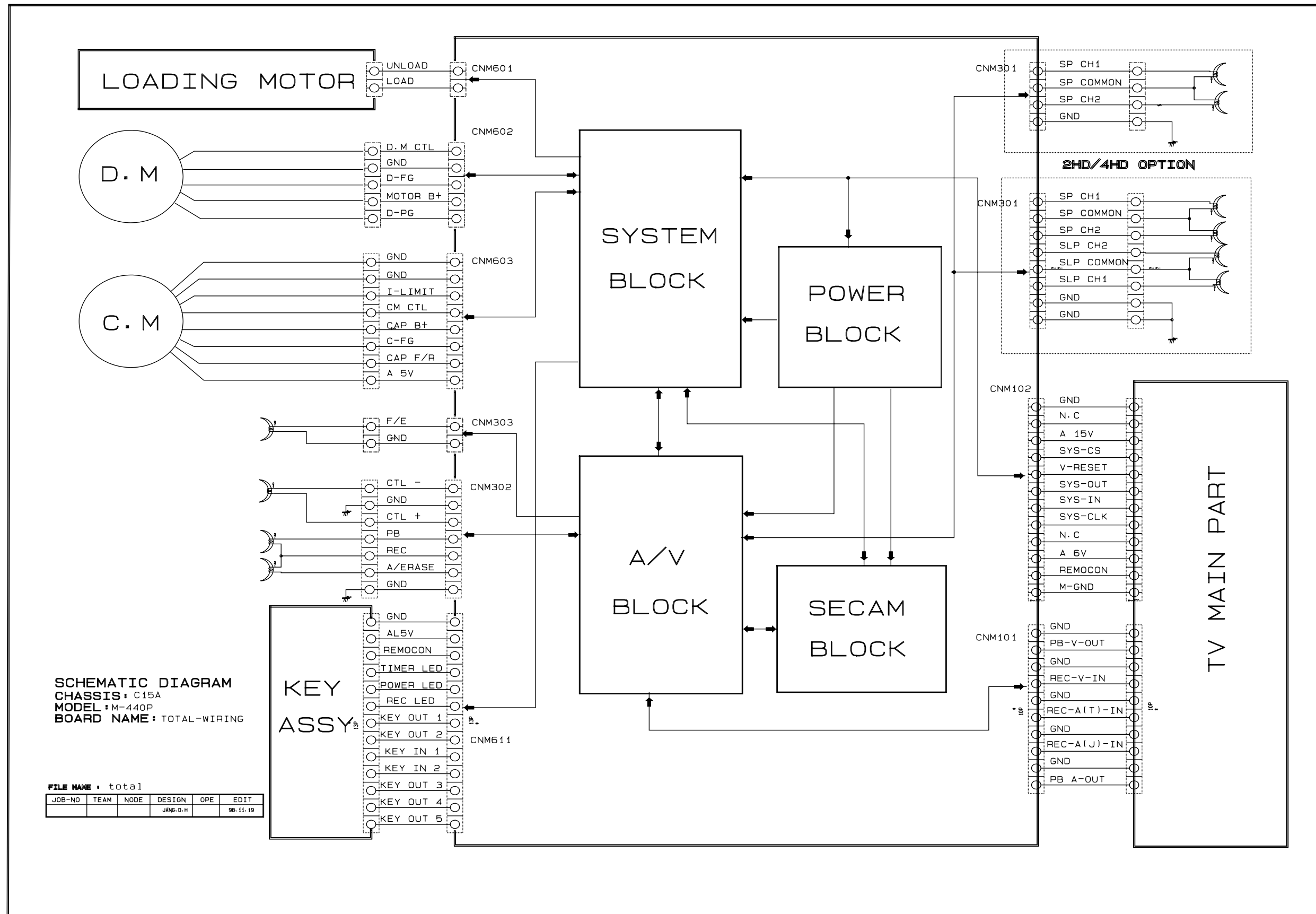

## 12. Schematic Diagrams

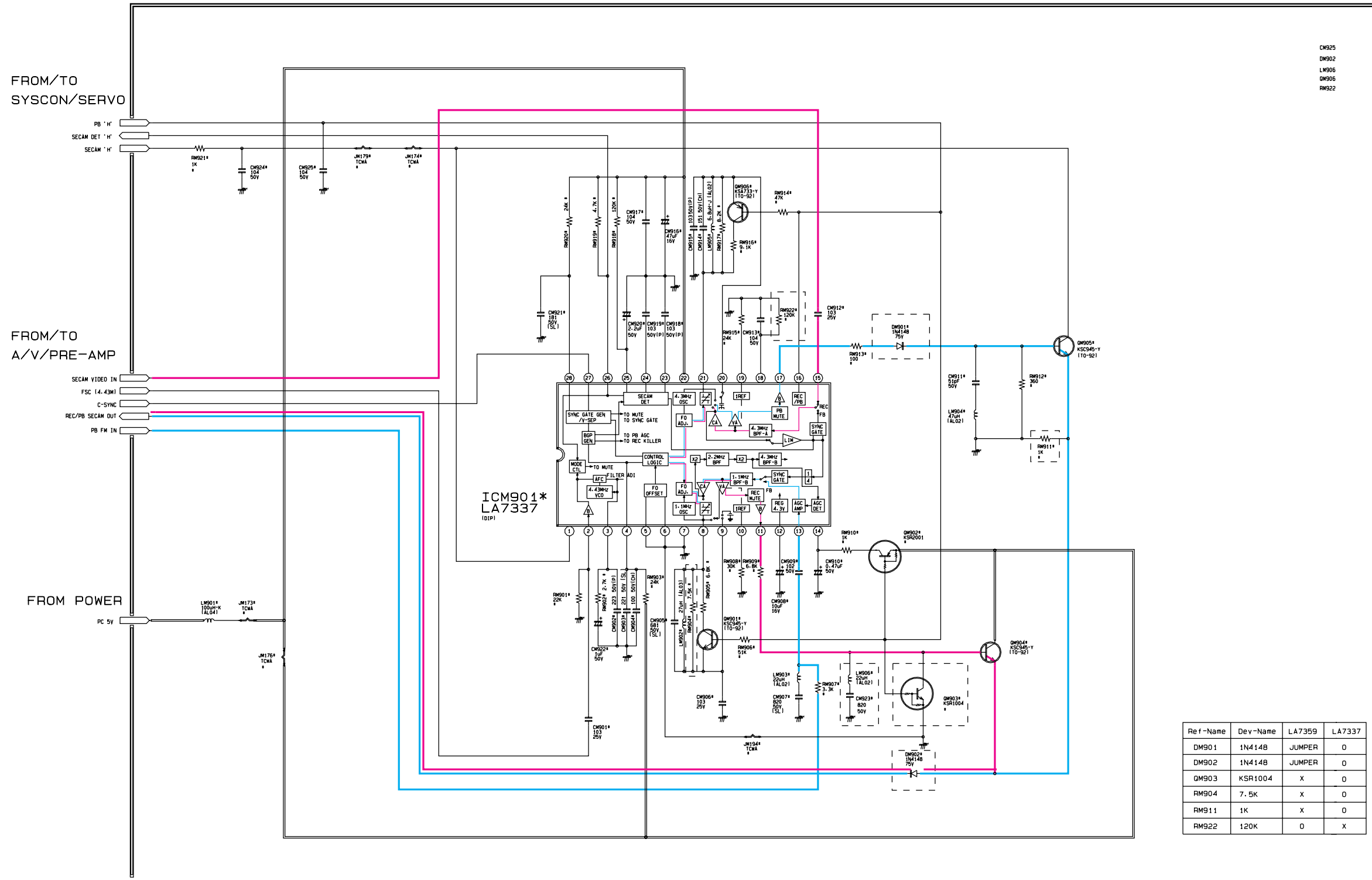

# 12-2 VCR (SYSTEM BLOCK)

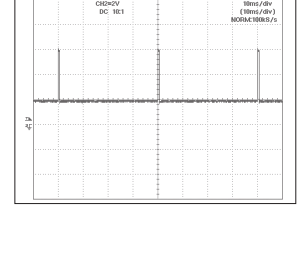
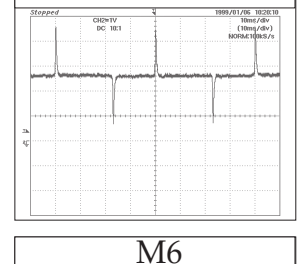
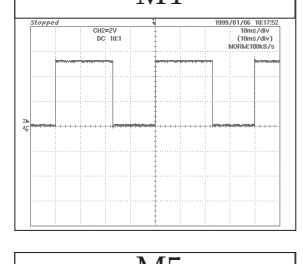
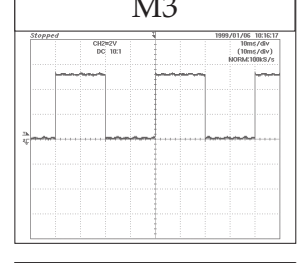
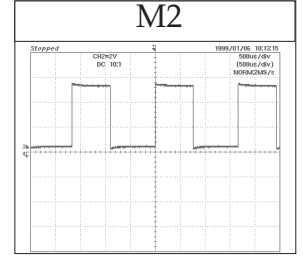
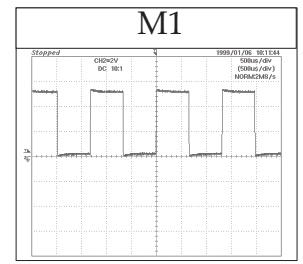
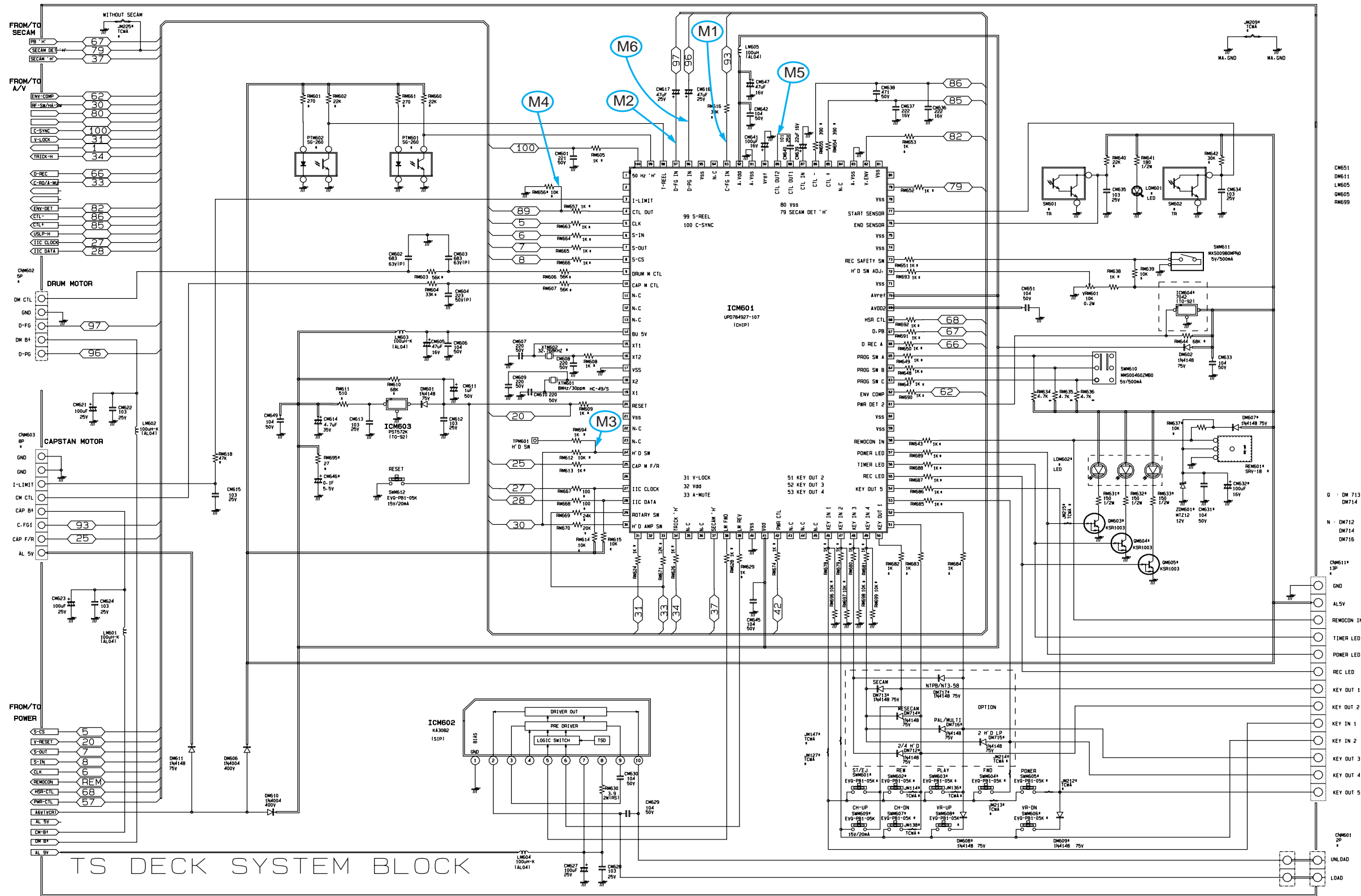

### 12-3 VCR (A/V BLOCK)

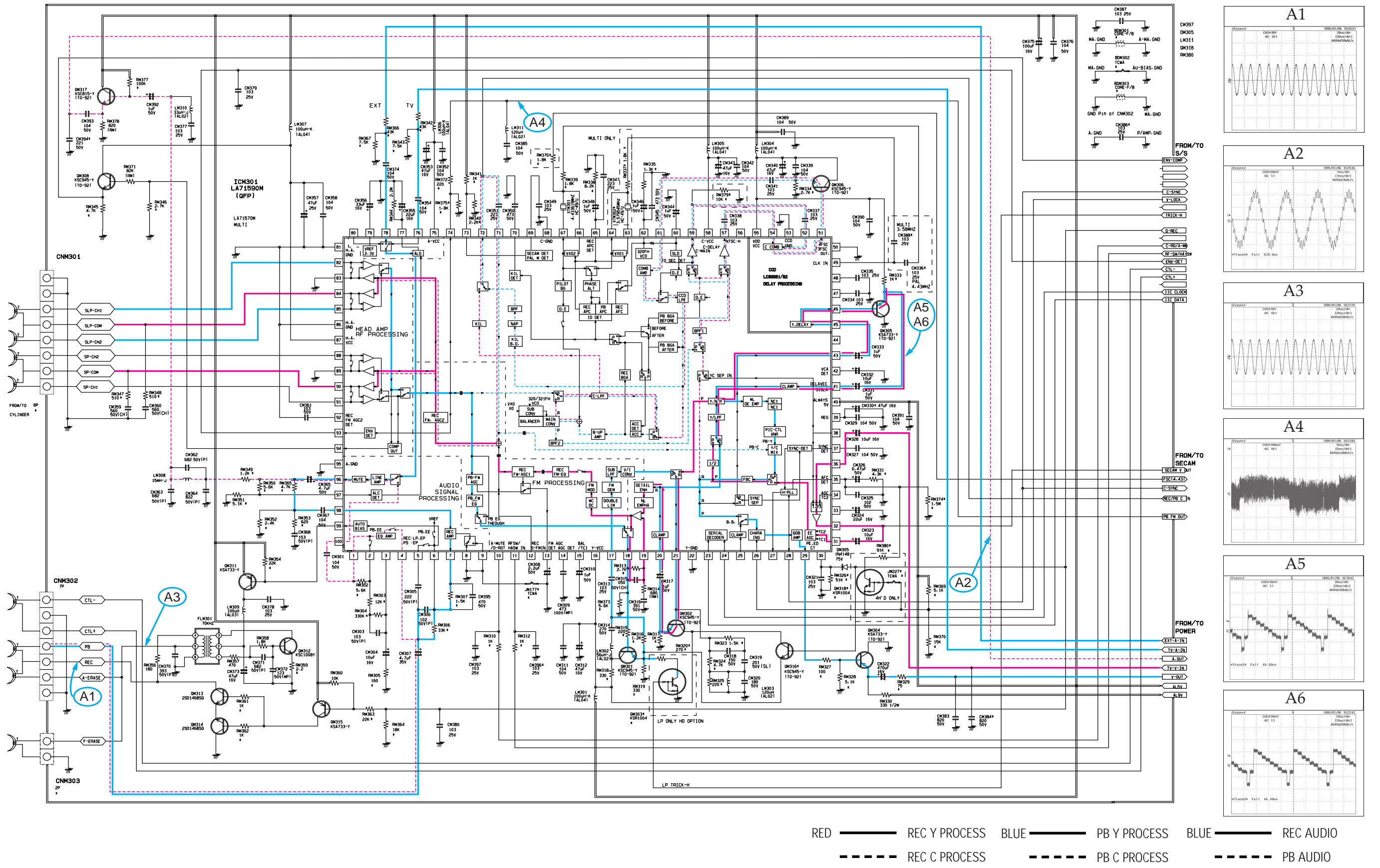



12-5 TV (1/4)

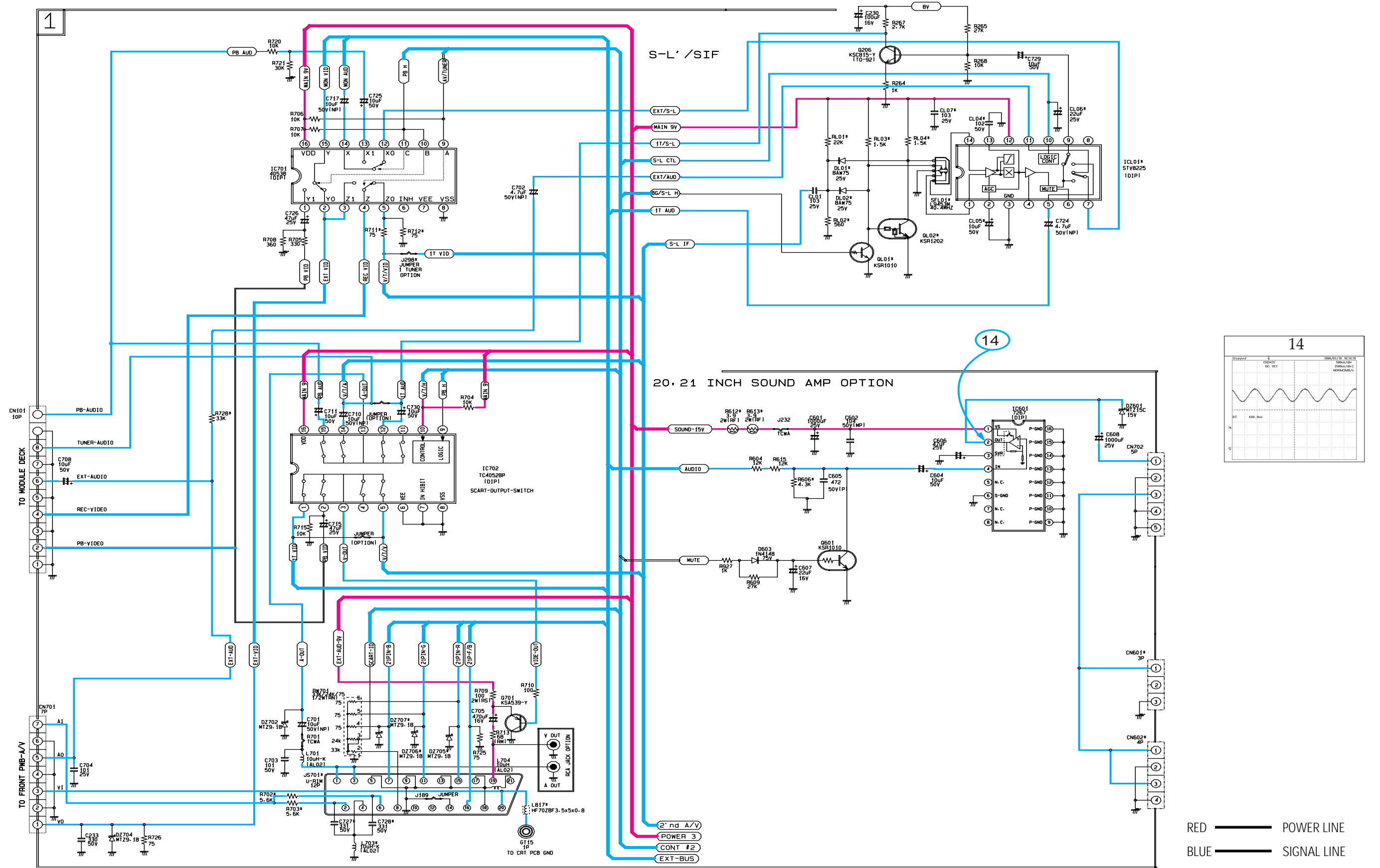

12-6 TV (2/4)

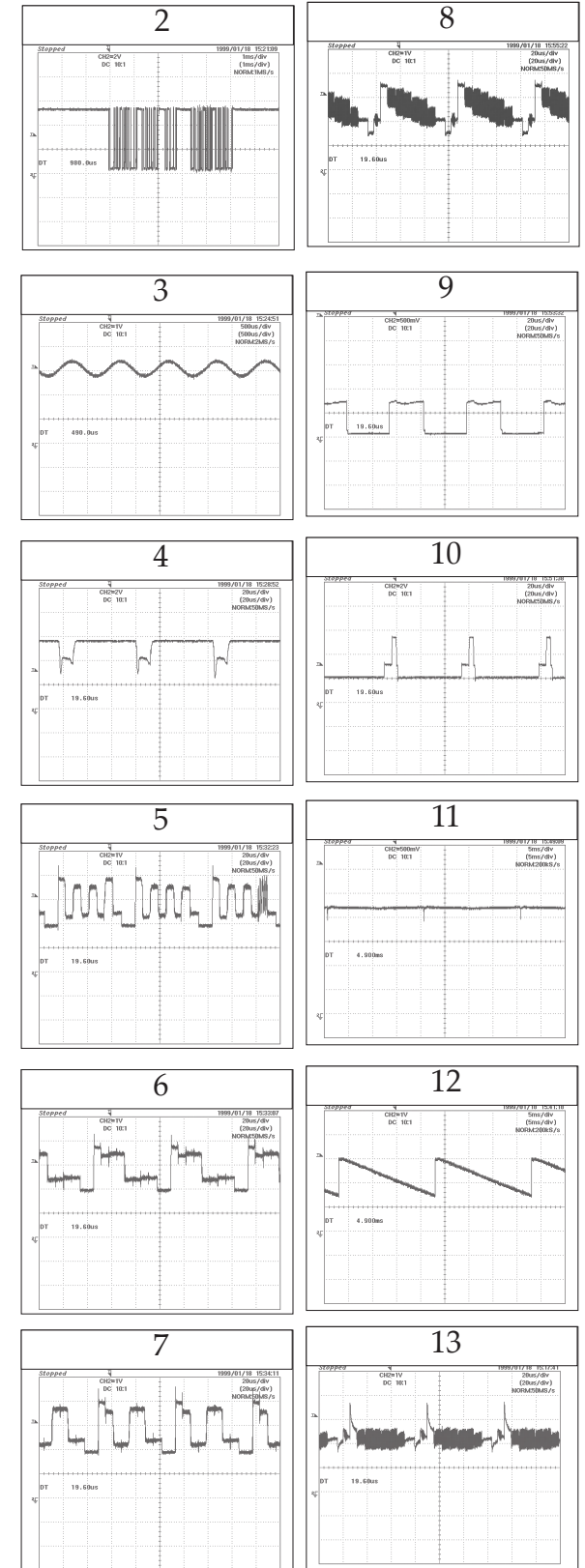
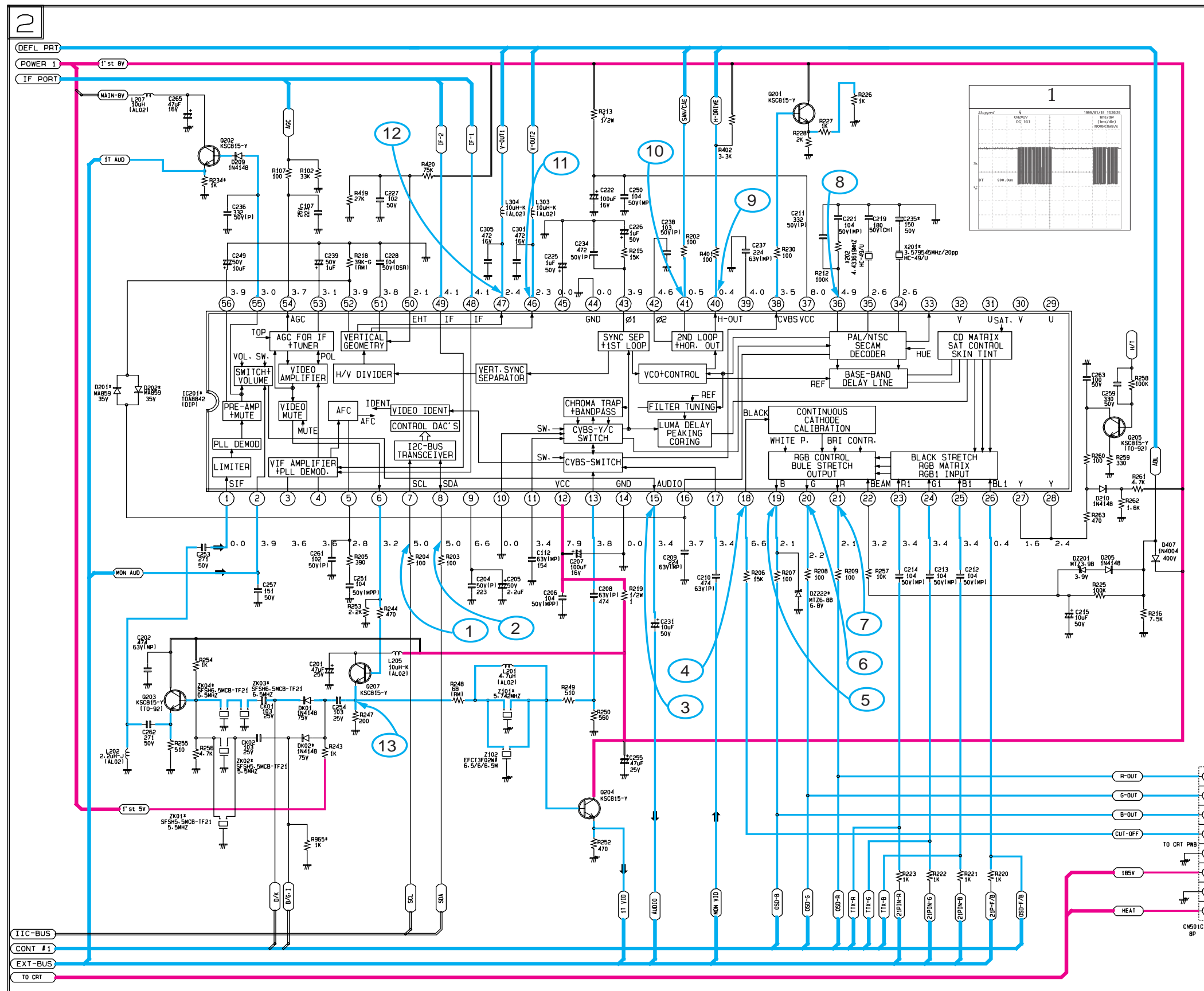

RED — POWER LINE  
 BLUE — SIGNAL LINE

12-7 TV (3/4)

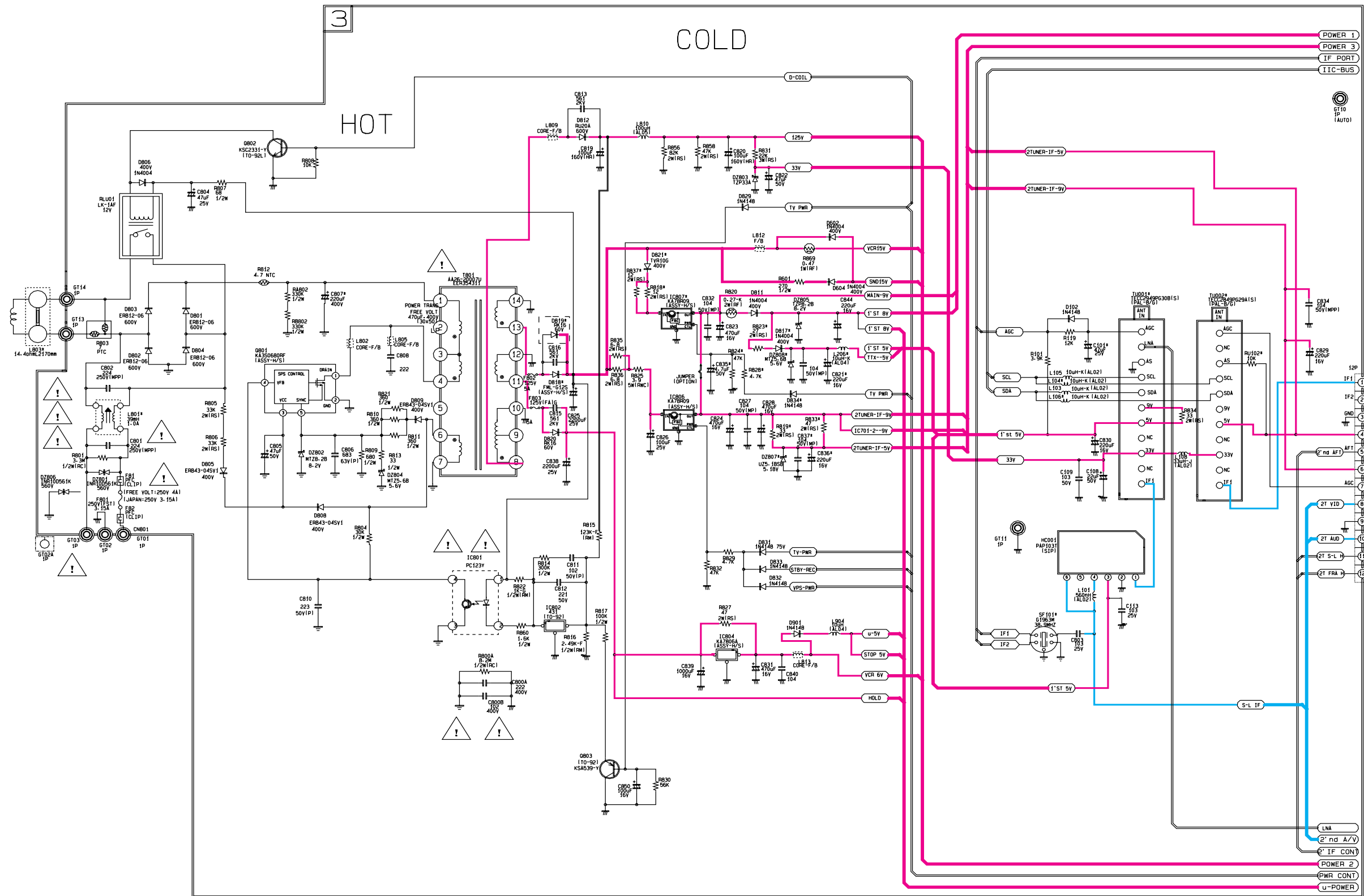

RED — POWER LINE  
 BLUE — SIGNAL LINE



12-9 IF

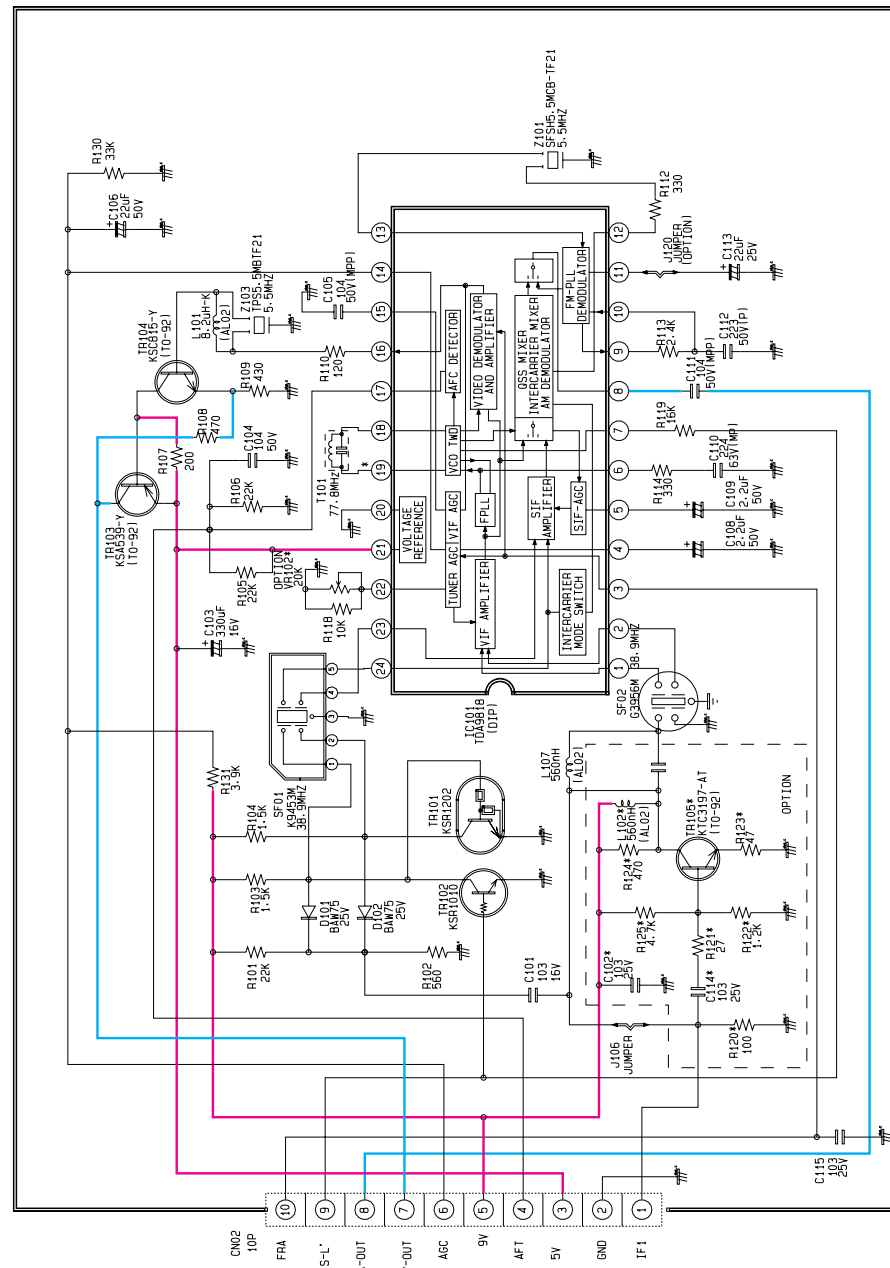

12-10 CRT

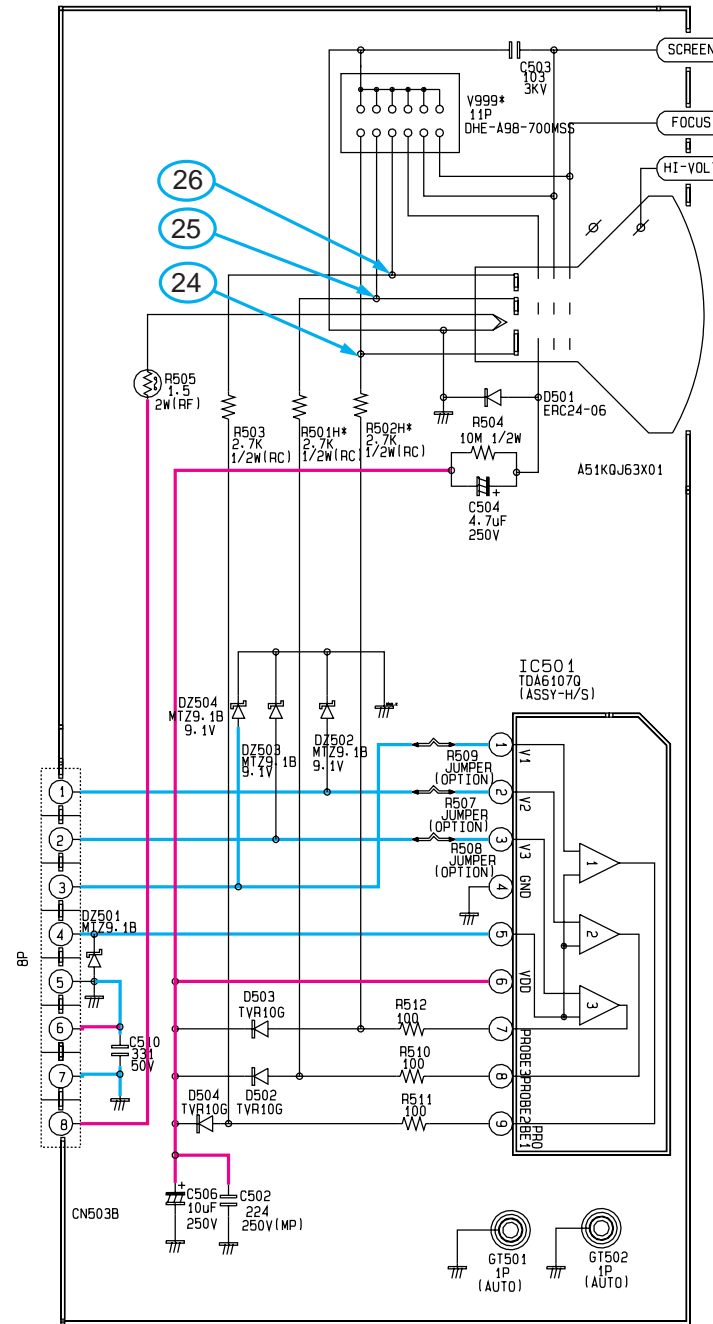

12-11 2'nd IF PAL/SECAM-B/G, D/K, I OPTION

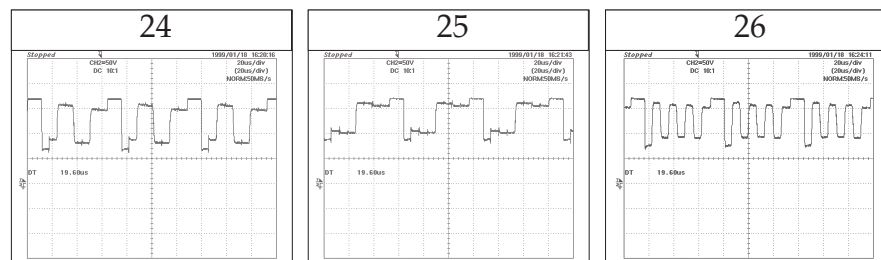
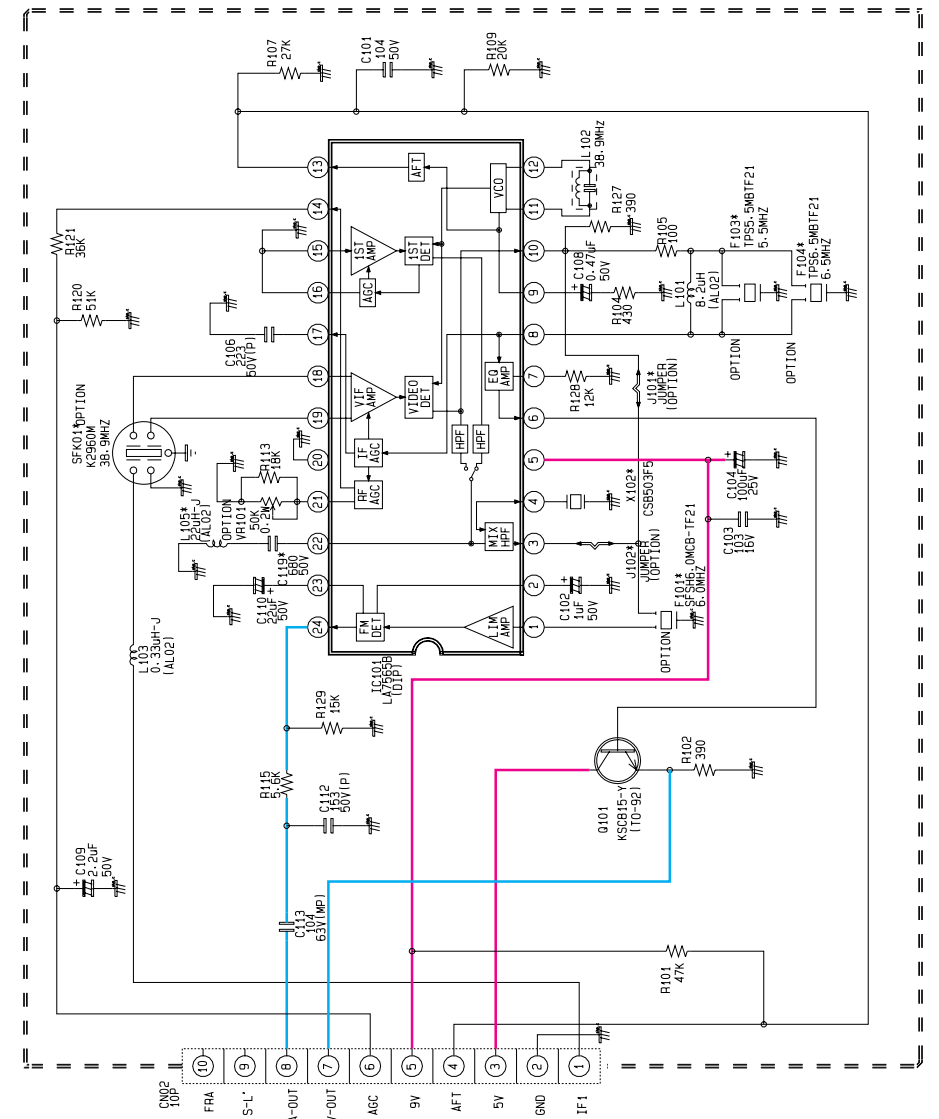

RED — POWER LINE  
 BLUE — SIGNAL LINE

### 12-12 TTX

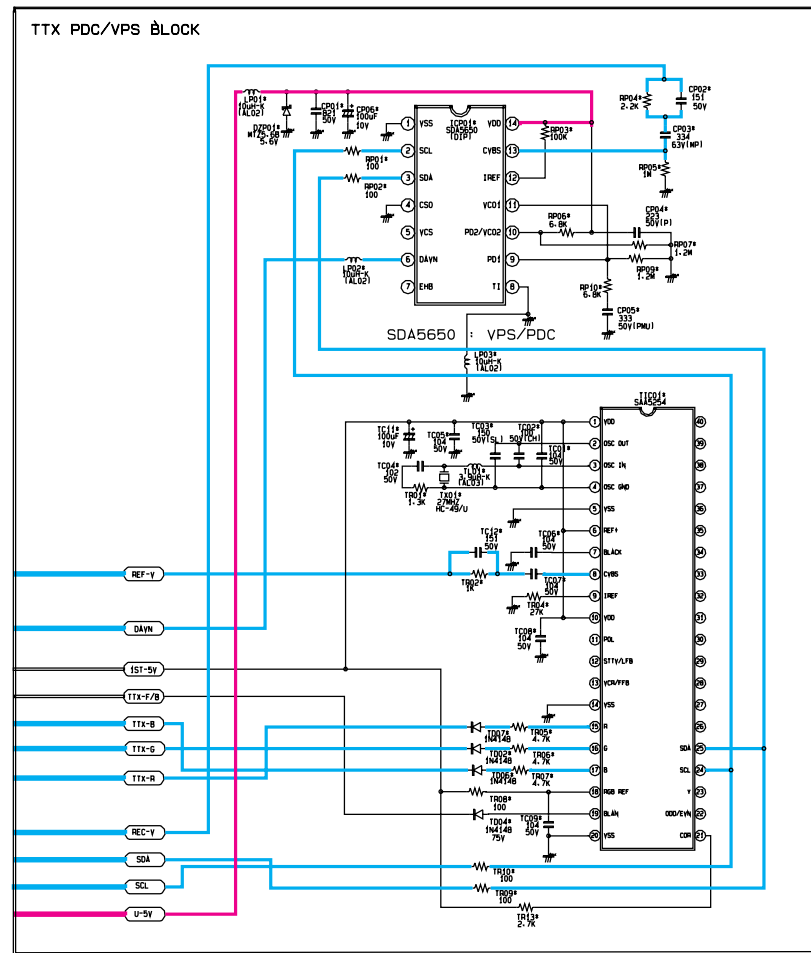

### 12-13 CONTROL

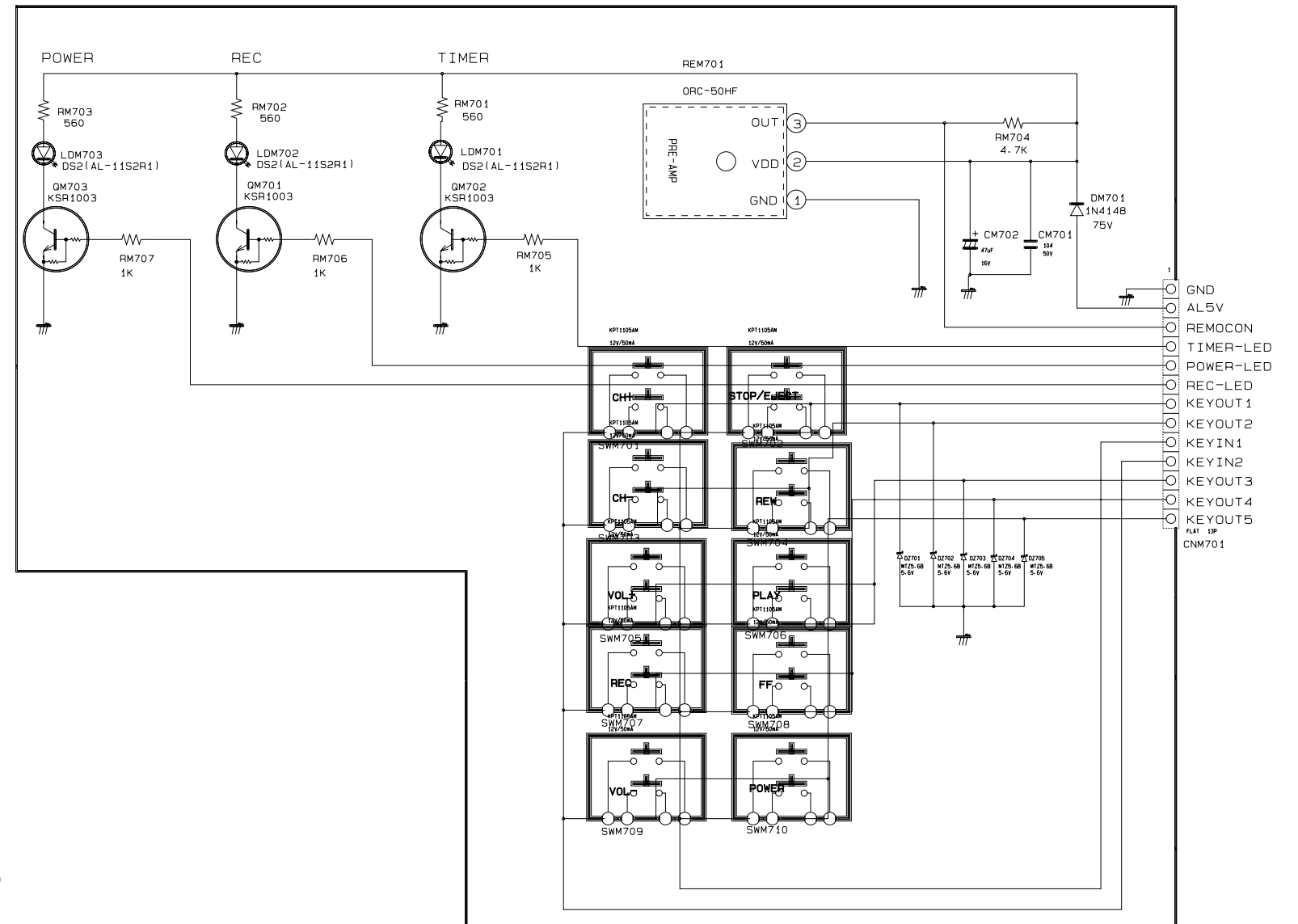

### 12-14 MASTER

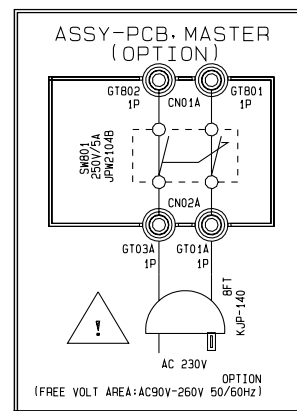

### 12-15 FRONT-A/V

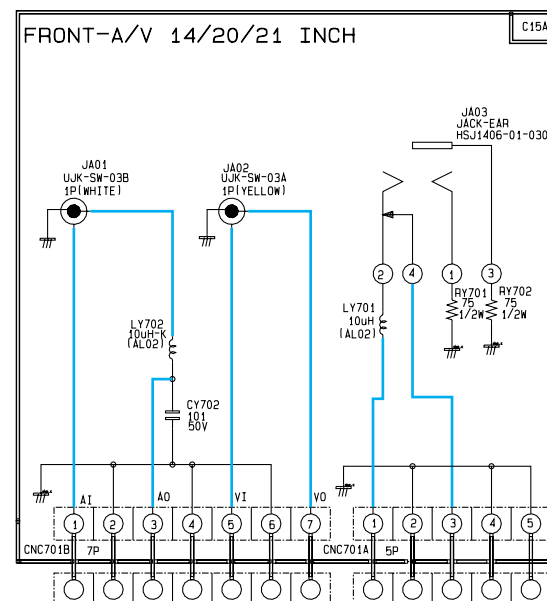

RED ——— POWER LINE  
 BLUE ——— SIGNAL LINE

## 12-16 Voltages (VTR)

ICM301

	PLAY	REC	STOP
1	2.5	2.5	2.5
2	2.5	2.5	2.5
3	2.5	2.5	2.5
4	2.5	2.5	2.5
5	2.5	2.5	0
6	2.5	2.5	2.5
7	2.5	2.5	2.5
8	0	0	0
9	0	0	0
10	1.6	1.6	2
11	3.2	3.2	3.2
12	5	2	2.5
13	1.5	1.5	2
14	1.5	1.5	1.6
15	2.2	2.2	2.2
16	5	5	5
17	3	0	0
18	1.8	2.1	2.2
19	2.1	2.1	2.2
20	2.8	2.8	3.2
21	2.1	2.1	2.5
22	0	0	0
23	5	5	5
24	5	5	5
25	1.8	1.8	2.8
26	0.8	0	1
27	4.1	4.1	4.1
28	4.1	4.1	4.1
29	0.8	0.8	3
30	1	0	1
31	2.1	2.1	3.5
32	1.8	1.8	2
33	2	2	1.5

	PLAY	REC	STOP
34	1.8	1.8	1.8
35	3.5	3.5	3.5
36	1.8	1.8	2
37	4.9	4.9	5
38	1.8	1.8	1.8
39	4	4	4
40	5	5	5
41	2.7	2.7	3
42	3	3	3.2
43	1.9	1.9	2
44	4.3	4.3	0
45	1.8	1.8	2
46	1.5	1.4	1.5
47	2	2	9
48	2.3	2.3	2.2
49	1.2	1.2	1
50	0	0	0
51	1.9	1.9	0
52	2.4	2.4	2.5
53	0	0	0
54	2.4	2.4	2.5
55	5	5	5
56	3.5	3.5	0
57	3.4	3.4	3.5
58	5	5	5
59	3.4	3.4	3.5
60	3.5	3.5	3.5
61	3.3	3.3	3.5
62	3.5	3.5	3.5
63	4	4	0
64	2.2	2.2	0
65	2.4	2.4	2.2
66	2.5	2.5	3

	PLAY	REC	STOP
67	4	4	4
68	0	0	0
69	0.7	0.7	0.7
70	2	2	2
71	2.5	2.5	2.5
72	0.3	2.5	3
73	2.5	2.5	3.5
74	2	0	2
75	5	5	5
76	2.5	2.5	2.5
77	0	0	0
78	2.5	2.5	0
79	2.5	2.5	2.5
80	2.5	5	2.5
81	0	0	0
82	1.8	4.1	1
83	0	0	0
84	1.8	4.1	1
85	1.8	4.1	1
86	0	0	0
87	5	5	5
88	1.8	4.1	2
89	0	0	0
90	1.8	4.1	2
91	1.8	4.1	2
92	4	1.6	0
93	4	4.0	0
94	0.5	0.7	0
95	0	0	0
96	2.5	2.5	2.5
97	0	0	0
98	2.5	2.5	2.5
99	5	4.3	5
100	2.5	2.5	2.5

ICM601

	PLAY	REC	STOP
1	5	5	5
2	0	0	0
3	5	5	5
4	5	5	5
5	5	5	5
6	5	5	5
7	5	5	5
8	5	5	5
9	5	5	0
10	5	5	0
11	0	0	0
12	0	0	0
13	0	0	0
14	5	5	5
15	3.5	3.5	3.5
16	4.5	4.5	4.5
17	0	0	0
18	4.5	4.5	4.5
19	3.5	3.5	3.5
20	5	5	5
21	0	0	0
22	0	0	0
23	0	0	0
24	5	5	0
25	5	5	0
26	0	0	0
27	5	5	5
28	5	5	5
29	5	5	0
30	0	0	0
31	0	0	0
32	5	5	5
33	0	0	0

	PLAY	REC	STOP
34	0	0	0
35	0	0	0
36	0	0	0
37	0	0	0
38	5	5	5
39	5	5	5
40	0	0	0
41	5	5	5
42	5	5	5
43	5	5	5
44	5	5	5
45	0	0	0
46	0	0	0
47	0	0	0
48	5	5	5
49	5	5	5
50	5	5	5
51	5	5	5
52	5	5	5
53	5	5	5
54	5	5	5
55	0	5	0
56	0	0	0
57	0	0	0
58	5	5	5
59	5	5	5
60	5	5	5
61	5	5	5
62	0	0	0
63	0	0	0
64	5	5	5
65	0	0	0
66	0	5	0

	PLAY	REC	STOP
67	5	0	0
68	0	0	0
69	5	5	5
70	5	5	5
71	0	0	0
72	1.8	1.8	1.8
73	0	0	0
74	0	0	0
75	0	0	0
76	0.7	0.7	0.7
77	0.7	0.7	0.7
78	0	0	0
79	0	0	0
80	0	0	0
81	0	0	0
82	4	0	0
83	0	0	0
84	0	0	0
85	2.5	5	2.5
86	2.5	5	2.5
87	2.5	2.5	2.5
88	2.5	2.5	2.5
89	2.5	2.5	2.5
90	2.5	2.5	2.5
91	0	0	0
92	5	5	5
93	5	5	5
94	0	5	0
95	0	0	0
96	5	5	5
97	5	5	5
98	5	5	0
99	5	5	0
100	5	5	5

ICM901

	PLAY	REC	STOP
1	4	0.8	0.8
2	2	2	2
3	4	4	4
4	3.5	3.5	3.5
5	0	0	0
6	0	0	0
7	0	0	0
8	2.5	2.5	2.5
9	2.5	2.5	2.5
10	2.5	2.5	2.5
11	2.5	2.5	2.5
12	4.5	4.5	4.5
13	2.5	2.5	2.5
14	2.5	4.7	4.5
15	3	2.5	2.5
16	5	1	1
17	2.5	2.5	2.5
18	2	2	2
19	2.5	2.5	2.5
20	2.5	2.5	2.5
21	2.5	2.5	2.5
22	5	5	5
23	3	3	3
24	3	3	3
25	4.1	3	3
26	5	0	0
27	4.1	4.1	4.1
28	3.1	3.1	3.1

ICM602

	PLAY	REC	STOP
1	0	0	0
2	0.4	0.4	0.4
3	1	1	1
4	0	0	0
5	3.5	3.5	3.5
6	3.5	3.5	3.5
7	9	9	9
8	9	9	9
9	1	1	1
10	0.5	0.5	0.5

## 12-17 Voltages (TV)

Q801 : KA3S0680RF

Units : Volts

PIN NO	PIN NAME	STAND-BY	POWER ON
1	DAR.IN	299	290
2	GND	-	-
3	VCC	19.5	20.3
4	VFB	0.2	1.3
5	SYNC	0.8	6.7

IC801 : PC123Y

Units : Volts

PIN NO	STAND-BY	POWER
1	16.5	16.7
2	15.4	15.7
3	GND	GND
4	0.2	1.3

IC501 : TDA6107Q

Units : Volts

PIN NO	PIN NAME	VOLTAGES(V)
1	B-IN	2.4
2	R-IN	2.4
3	G-IN	2.5
4	GND	-
5	Iom	5.4
6	Vdd	166
7	G-OUT	90-115
8	R-OUT	93-118
9	B-OUT	97-119

IC301 : TDA8356

Units : Volts

PIN NO	PIN NAME	VOLTAGES(V)
1	VD-INPUT	2.2
2	VD+INPUT	2.2
3	VCC	16.9
4	OUTPUT	8.2
5	GND	-
6	VFB	41.5
7	OUT	8.5
8	VO	-
9	VI	8.2

TIC01 : SAA5254

Units : Volts

PIN NO	PIN NAME	VOLTAGES(V)
1	VDD	5.0
2	OSC OUT	2.4
3	OSC IN	4.0
4-5	-	-
6	REF+	5.0
7	BLACK	2.1
8	CVBS	2.5
9	IREF	2.5
10	VDD	5.0
11-17	-	-
18	RGB REF	5.0
19	BLAN	1.6
20	VSS	-
21	COR	5.0
22-23	-	-
24	SCL	4.8
25	SDA	4.8
26-40	-	No.Used

IC902 : 24C08,24C04

Units : Volts

PIN NO	PIN NAME	VOLTAGES(V)
1-4	GND	-
5	SDA	4.8
6	SCL	4.8
7	GND	-
8	VDD	5.2

IC601 : TDA7267

Units : Volts

PIN NO	PIN NAME	VOLTAGES(V)
1	VS	1.6
2	OUT	8.5
3	SVR	8.7
4	IN	0.8
5	N.C	-
6	S-GND	-
7-8	N.C	-
9-16	P-GND	-

IC901 : CXP85340A-329S

Units : Volts

PIN NO	PIN NAME	VOLTAGES(V)	PIN NO	PIN NAME	VOLTAGES(V)
1	H-sync	1.3	37	V.NURE	-
2	V-sync	-	38	S.MUTE	5.1
3	TV POWER	5.2	39	1T/AGC	4.6
4	VPS POWER	-	40	2T AFT	2.4
5	STBY-REC	-	41	1T AFT	-
6	PB-H	-	42	SCART ID	-
7	V/T/H	-	43	BUS STOP	5.2
8	AV/TUNER	-	44	P.OFF DET	5.5
9	2nd NT H	5.2	45	XLC	3.1
10	1st NT H	5.2	46	EXLC	3.1
11	D-coil	-	47	OSD R	-
12-22	Not used	5.1	48	OSD G	-
23	SCL	4.8	49	OSD B	-
24	SDA	4.8	50	N.C	-
25	Not used	5.2	51	F/B	-
26	REMOCON	4.5	52	H/T	-
27	VCR RESET	-	53	BG/I L	-
28	TV CS	4.8	54	D/K L	-
29	TV SI	4.1	55	1T S-L H	-
30	TV SO	2.6	56	S-L H	-
31	TV CLK	5.1	57	FRA H	-
32	Vss	-	58	N.C	-
33	DAVN	5.2	59	LNA	4.4
34	Xtal	2.5	60	S-L CTL	-
35	EXtal	2.4	61-62	GND	-
36	RESET	5.2	63-64	VDD	5.1

### 12-18 Voltages (TV)

TIC01 : SAA5254 Units : Volts

PIN NO	PIN NAME	VOLTAGE(V)
1	VDD	5.0
2	OSC OUT	2.4
3	OSC IN	4.0
4-5	-	-
6	REF+	5.0
7	BLACK	2.1
8	CVBS	2.5
9	IREF	2.5
10	VDD	5.0
11-17	-	-
18	RGB REF	5.0
19	BLAN	1.6
20	VSS	-
21	COR	5.0
22-23	-	-
24	SCL	4.8
25	SDA	4.8
26-40	-	No.Used

Units : Volts

LOC	IC101*	IC101*	IC701	IV702	ICL01*	ICP01*
IC PIN NO	TDA9818 2T-IF(F)	LA7565B 2T-IF(W)	TC4053BP	TC4052BP	STV8225	SDA5650
1	3.3	2.0	-	1.6	4.2	-
2	3.3	2.2	-	0.5	3.2	4.8
3	-	7.4	-	1.6	-	4.8
4	2.0	8.0	1.1	-	0.6	-
5	2.1	8.9	1.1	2.2	4.3	0.4
6	3.9	3.8	-	-	3.5	5.2
7	1.7	3.2	-	-	4.3	-
8	2.4	2.7	-	-	6.3	-
9	2.3	3.7	0.8	0.8	4.3	2.6
10	2.3	2.7	0.8	0.8	3.5	2.6
11	1.6	8.3	0.8	-	4.3	2.6
12	2.0	8.3	2.2	4.0	9.0	1.5
13	2.7	0.3	-	3.4	4.3	1.5
14	4.2	7.9	2.1	2.2	4.3	5.2
15	1.4	-	-	0.4		
16	1.9	-	8.9	8.9		
17	0.4	2.9				
18	2.6	3.4				
19	2.6	3.4				
20	-	-				
21	4.9	1.7				
22	0.8	2.4				
23	3.2	3.3				
24	3.2	3.3				

IC201 : TDA8842/8841 Units : Volts

PIN NO	PIN NAME	VOLTAGE(V)
1	SOUND IF INPUT	-
2	EXT.AUDIO INPUT	3.6
3	N.C	-
4	N.C	-
5	PLL LOOPFILTER	2.4
6	IF VIDEO OUTPUT	3.2
7	SCL	4.8
8	SDA	4.8
9	BANDGAP DECOUPLING	6.6
10	CHROMA INPUT	-
11	Y/CVBS INPUT	3.3
12	MAIN POSITIVE SUPPLY	8.0
13	INT.CVBS INPUT	3.9
14	GND	-
15	AUDIO OUT	3.0
16	SECAM DECOUPLING	-
17	EXT.CVBS INPUT	3.3
18	BLACK CURRENT INPUT	5.0
19	BLUE OUTPUT	3.0
20	GREEN OUTPUT	3.2
21	RED OUTPUT	3.2
22	V-GUARD INP / BEAM CUR.LIMITTER	2.0
23	RED INPUT	3.4
24	GREEN INTPUT	3.4
25	BLUE INTPUT	3.4
26	RGB INSERTION SWITCH INP	0.1
27	LUMINANCE INPUT	2.6
28	LUMINANCE OUTPUT	2.6
29	B-Y OUTPUT	-
30	R-Y OUTPUT	-

PIN NO	PIN NAME	VOLTAGE(V)
31	B-Y OUTPUT	-
32	R-Y OUTPUT	-
33	SUBCARRIER OUTPUT	-
34	X-TAL(3.58)	2.4
35	X-TAL(4.43/3.58)	2.4
36	LOOPFILTER BURST PHASE DET	4.9
37	POSITIVE SUPPLY	8.0
38	CVBS OUTPUT	2.7
39	DECDIG	4.9
40	HOR OUTPUT	0.3
41	SANDCASTLE OUTP/FLY-BACK INP	0.5
42	PHI2 FILTER / FLASHPROT	3.2
43	PHI1 FILTER	3.9
44	GND	-
45	EAST-WEST DRIVE/AVL OUTPUT	-
46	VERT.DRIVE POS	2.2
47	VERT.DRIVE NEG	2.2
48	IF INPUT	4.5
49	IF INPUT	4.5
50	EHT/OVERVOLTAGE PROTECTION INP	2.1
51	VERT.SAWTOOTH CAPACITOR	3.7
52	REFERENCE CURRENT INPUT	3.8
53	AGC DECOUPLING CAPACITOR	4.2
54	TUNER AGC INPUT	4.4
55	AUDIO DEEMPHASSIS	2.8
56	DECOUPLING SOUND DEMODULATOR	2.4