



Television Video Cassette Recorder

Chassis : SCV11F
Model: TB531VCT1X/XSA
TB331VDZ1S/XSA

SERVICE Manual

Television Video Cassette Recorder



CONTENTS

1. Precautions
2. Specifications
3. Disassembly and Reassembly
4. Alignment and Adjustment (Mechanical)
5. Alignment and Adjustment (Electrical)
6. Troubleshooting
7. Exploded View and Parts List
8. Electric Parts List
9. Block Diagram
10. PCB Layout
11. Wiring Diagram
12. Schematic Diagrams



ELECTRONICS

1. Precautions

Follow these safety, servicing and ESD precautions to prevent damage and protect against potential hazards such as electrical shock and X-rays.

1-1 Safety Precautions

1. Be sure that all of the built-in protective devices are replaced. Restore any missing protective shields.
2. When reinstalling the chassis and its assemblies, be sure to restore all protective devices, including: nonmetallic control knobs and compartment covers.
3. Make sure that there are no cabinet openings through which people—particularly children—might insert fingers and contact dangerous voltages. Such openings include the spacing between the picture tube and the cabinet mask, excessively wide cabinet ventilation slots, and improperly fitted back covers.

If the measured resistance is less than 1.0 megohm or greater than 5.2 megohms, an abnormality exists that must be corrected before the unit is returned to the customer.

4. Leakage Current Hot Check (Figure 1-1):
Warning: Do not use an isolation transformer during this test. Use a leakage-current tester or a metering system that complies with American National Standards Institute (ANIS C101.1, Leakage Current for Appliances), and Underwriters Laboratories (UL Publication UL1410, 59.7).
5. With the unit completely reassembled, plug the AC line cord directly into the power outlet. With the unit's AC switch first in the ON position and then OFF, measure the current between a known earth ground (metal water pipe, conduit, etc.) and all exposed metal parts, including: antennas, handle brackets, metal cabinets, screwheads and control shafts. The current measured should not exceed 0.5 milliamp. Reverse the power-plug prongs in the AC outlet and repeat the test.

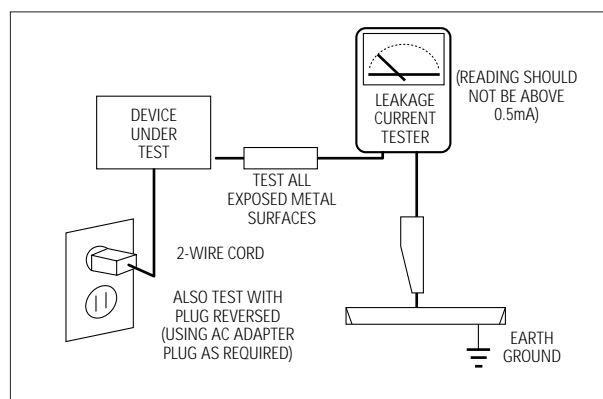

Fig. 1-1 AC Leakage Test



6. Antenna Cold Check:
With the unit's AC plug disconnected from the AC source, connect an electrical jumper across the two AC prongs. Connect one lead of the ohmmeter to an AC prong. Connect the other lead to the coaxial connector.
7. X-ray Limits:
The picture tube is especially designed to prohibit X-ray emissions. To ensure continued X-ray protection, replace the picture tube only with one that is the same type as the original. Carefully reinstall the picture tube shields and mounting hardware; these also provide X-ray protection.
8. High Voltage Limits:
High voltage must be measured each time servicing is done on the B+, horizontal deflection or high voltage circuits. Correct operation of the X-ray protection circuits must be reconfirmed whenever they are serviced.
(X-ray protection circuits also may be called "horizontal disable" or "hold-down".)

Heed the high voltage limits. These include the X-ray Protection Specifications Label, and the Product Safety and X-ray Warning Note on the service data schematic.

1-1 Safety Precautions (Continued)

9. High voltage is maintained within specified limits by close-tolerance, safety-related components and adjustments. If the high voltage exceeds the specified limits, check each of the special components.
10. Design Alteration Warning:
Never alter or add to the mechanical or electrical design of this unit. Example: Do not add auxiliary audio or video connectors. Such alterations might create a safety hazard. Also, any design changes or additions will void the manufacturer's warranty.
11. Hot Chassis Warning:
Some TV receiver chassis are electrically connected directly to one conductor of the AC power cord. If an isolation transformer is not used, these units may be safely serviced only if the AC power plug is inserted so that the chassis is connected to the ground side of the AC source.

To confirm that the AC power plug is inserted correctly, do the following: Using an AC voltmeter, measure the voltage between the chassis and a known earth ground. If the reading is greater than 1.0V, remove the AC power plug, reverse its polarity and reinsert. Re-measure the voltage between the chassis and ground.
12. Some TV chassis are designed to operate with 85 volts AC between chassis and ground, regardless of the AC plug polarity. These units can be safely serviced only if an isolation transformer inserted between the receiver and the power source.
13. Some TV chassis have a secondary ground system in addition to the main chassis ground. This secondary ground system is not isolated from the AC power line. The two ground systems are electrically separated by insulating material that must not be defeated or altered.
14. Components, parts and wiring that appear to have overheated or that are otherwise damaged should be replaced with parts that meet the original specifications. Always determine the cause of damage or overheating, and correct any potential hazards.
15. Observe the original lead dress, especially near the following areas: Antenna wiring, sharp edges, and especially the AC and high voltage power supplies. Always inspect for pinched, out-of-place, or frayed wiring. Do not change the spacing between components and the printed circuit board. Check the AC power cord for damage. Make sure that leads and components do not touch thermally hot parts.
16. Picture Tube Implosion Warning:
The picture tube in this receiver employs "integral implosion" protection. To ensure continued implosion protection, make sure that the replacement picture tube is the same as the original.
17. Do not remove, install or handle the picture tube without first putting on shatterproof goggles equipped with side shields. Never handle the picture tube by its neck. Some "in-line" picture tubes are equipped with a permanently attached deflection yoke; do not try to remove such "permanently attached" yokes from the picture tube.
18. Product Safety Notice:
Some electrical and mechanical parts have special safety-related characteristics which might not be obvious from visual inspection. These safety features and the protection they give might be lost if the replacement component differs from the original—even if the replacement is rated for higher voltage, wattage, etc.

Components that are critical for safety are indicated in the circuit diagram by shading, () or ().
Use replacement components that have the same ratings, especially for flame resistance and dielectric strength specifications. A replacement part that does not have the same safety characteristics as the original might create shock, fire or other hazards.

1-2 Servicing Precautions

Warning1: First read the "Safety Precautions" section of this manual. If some unforeseen circumstance creates a conflict between the servicing and safety precautions, always follow the safety precautions.

Warning2: An electrolytic capacitor installed with the wrong polarity might explode.

1. Servicing precautions are printed on the cabinet. Follow them.
2. Always unplug the unit's AC power cord from the AC power source before attempting to: (a) Remove or reinstall any component or assembly, (b) Disconnect an electrical plug or connector, (c) Connect a test component in parallel with an electrolytic capacitor.
3. Some components are raised above the printed circuit board for safety. An insulation tube or tape is sometimes used. The internal wiring is sometimes clamped to prevent contact with thermally hot components. Reinstall all such elements to their original position.
4. After servicing, always check that the screws, components and wiring have been correctly reinstalled. Make sure that the portion around the serviced part has not been damaged.
5. Check the insulation between the blades of the AC plug and accessible conductive parts (examples: metal panels, input terminals and earphone jacks).
6. Insulation Checking Procedure: Disconnect the power cord from the AC source and turn the power switch ON. Connect an insulation resistance meter (500V) to the blades of the AC plug.

The insulation resistance between each blade of the AC plug and accessible conductive parts (see above) should be greater than 1 megohm.
7. Never defeat any of the B+ voltage interlocks. Do not apply AC power to the unit (or any of its assemblies) unless all solid-state heat sinks are correctly installed.
8. Always connect a test instrument's ground lead to the instrument chassis ground before connecting the positive lead; always remove the instrument's ground lead last.

1-3 Precautions for Electrostatically Sensitive Devices (ESDs)

1. Some semiconductor (“solid state”) devices are easily damaged by static electricity. Such components are called Electrostatically Sensitive Devices (ESDs); examples include integrated circuits and some field-effect transistors. The following techniques will reduce the occurrence of component damage caused by static electricity.
2. Immediately before handling any semiconductor components or assemblies, drain the electrostatic charge from your body by touching a known earth ground. Alternatively, wear a discharging wrist-strap device. (Be sure to remove it prior to applying power—this is an electric shock precaution.)
3. After removing an ESD-equipped assembly, place it on a conductive surface such as aluminum foil to prevent accumulation of electrostatic charge.
4. Do not use freon-propelled chemicals. These can generate electrical charges that damage ESDs.
5. Use only a grounded-tip soldering iron when soldering or unsoldering ESDs.
6. Use only an anti-static solder removal device. Many solder removal devices are not rated as “anti-static”; these can accumulate sufficient electrical charge to damage ESDs.
7. Do not remove a replacement ESD from its protective package until you are ready to install it. Most replacement ESDs are packaged with leads that are electrically shorted together by conductive foam, aluminum foil or other conductive materials.
8. Immediately before removing the protective material from the leads of a replacement ESD, touch the protective material to the chassis or circuit assembly into which the device will be installed.
9. Minimize body motions when handling unpackaged replacement ESDs. Motions such as brushing clothes together, or lifting a foot from a carpeted floor can generate enough static electricity to damage an ESD.

2. Specifications

TELEVISION	
Colour system Optional Systems Number of channels Tuning Range: Off-Air/Cable Aerial input	PAL/SECAM Multistandard L/L' (Option), B/G (Option), D/K (Option), I (Option) 100 Hyperband/interband tuner 75 Ohms, coaxial cable
VCR	
Format Heads Video system Audio system Luminance Colour Wow and flutter (WTD) Frequency response	VHS standard (PAL/SECAM Option)/MESECAM (Option) /NTSC (playback only) Video: 2 rotary heads, LP (Option), 4 Heads (Option) Audio/Control: 1 stationary head (linear) Erase: 1 full track erase head CCIR standard Mono FM azimuth recording Down converted subcarrier phase shifted direct recording 0.4% maximum (SP) 100Hz - 8 KHz
GENERAL	
Power supply Consumption Audio output power Number of loudspeakers Tube size Tube type Sockets Dimensions (W x D x H) Weight Operating temperature Relative humidity	220~240V; 50Hz; Option: 110~260V, 50~60Hz 14 Inch (80W), 20 Inch (100W), 21 Inch (105W) 14 Inch (2.0 watts), 20 Inch, 21 Inch (2Watts x 2) 14 Inch (1), 20 Inch, 21 Inch (2) 14" (37 cm), or 20" (51 cm), 21" (55 cm) BLACK MATRIX 1 full RGB SCART: Rear (Option); 1 RCA output (Option): Rear 1 RCA input (audio and video): Front Earphones (3.5 mm mini-jack) 1 aerial/cable TV coaxial input 14 Inch (362x383x382), 20 Inch (482x465x479), 21 Inch (502x494x498) 14 Inch (12.5kg), 20 Inch (22KG), 21 Inch (25kg) 5°C - 40°C (41°F-104°F) 10%-75%

MEMO

3. Disassembly and Reassembly

3-1 Disassembly

3-1-1 Back Cover Removal

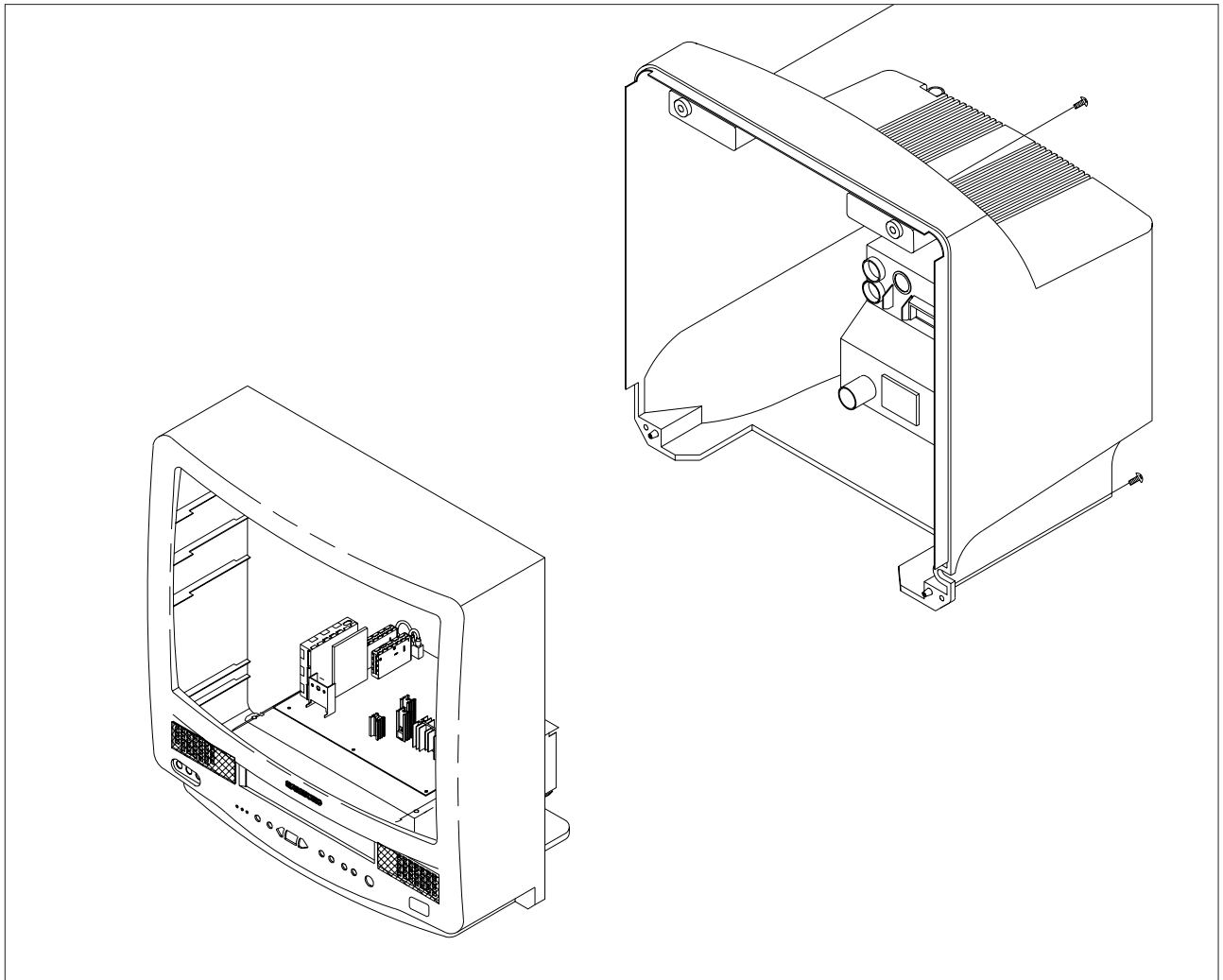

Fig. 3-1

1. Remove the screws located on the side of the back cover.
2. Pull the Main Assembly backward and remove it from the front cabinet.

3-1-2 Main Assembly Removal

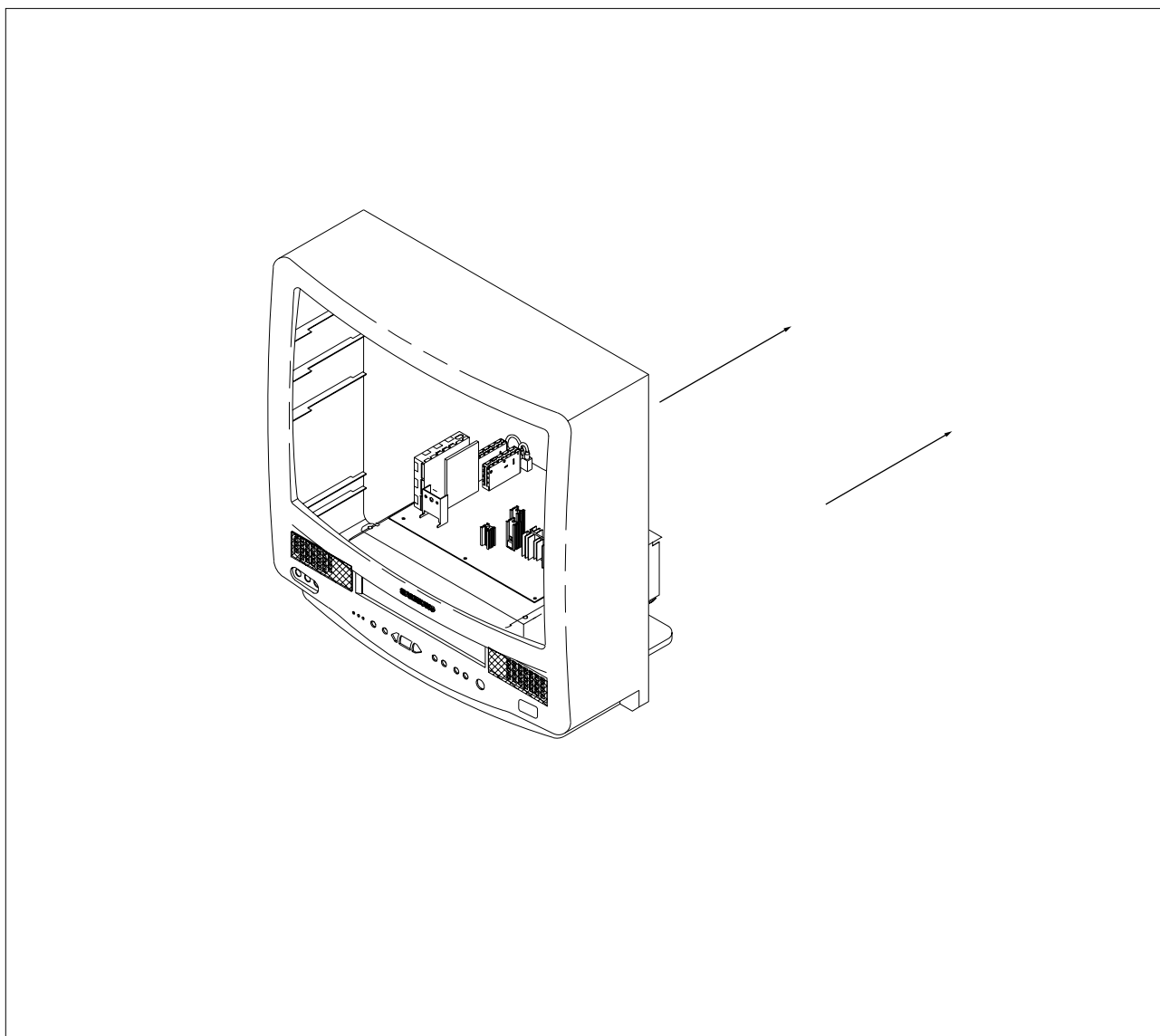

Fig. 3-2

1. Release two connectors between sub PCB and Main Assembly.
2. Pull the Main Assembly backward. Remove it from the front cabinet.

3-1-3 Monitor Frame Removal

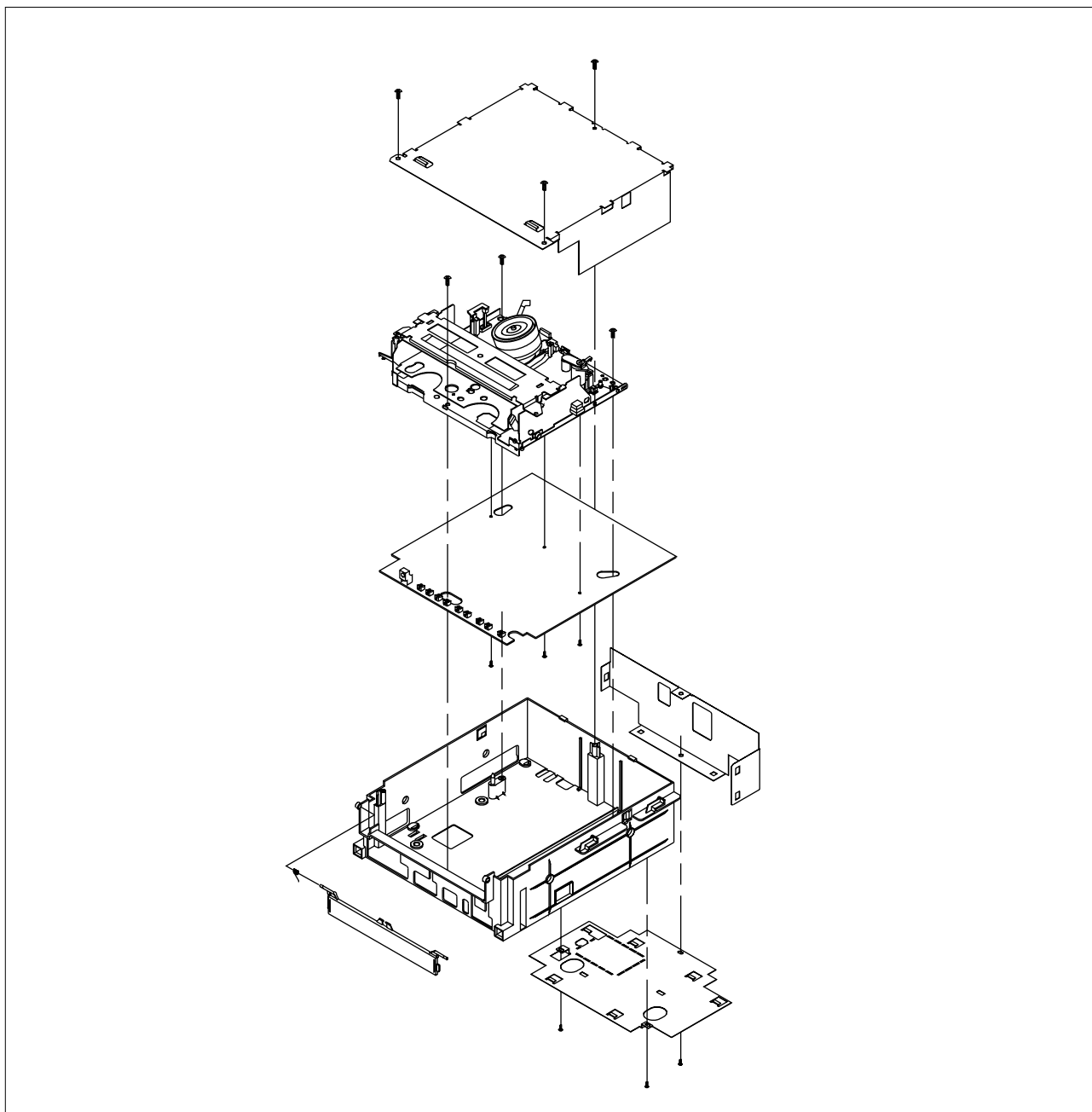
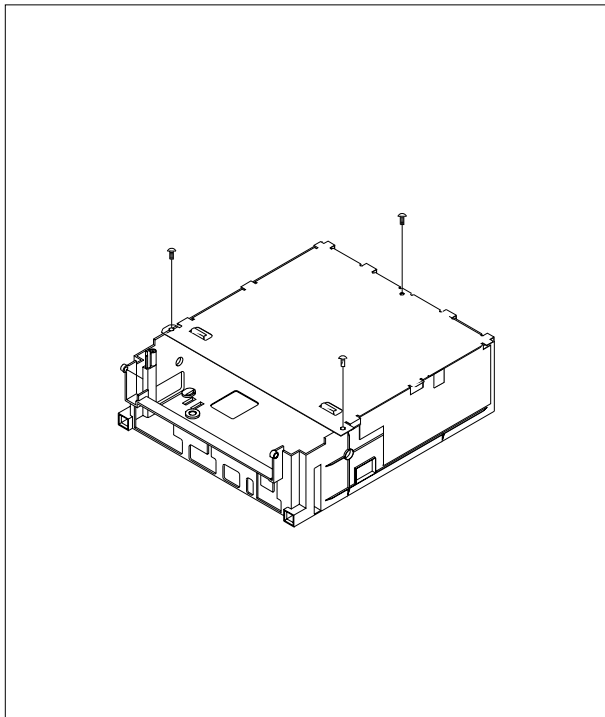

Fig. 3-3

1. Remove 2 screws from the Main Assembly. Remove the dust cover.
2. Remove 2 screws from the Deck Assembly. Remove the dust-cover bracket.

3-1-4 Deck Assembly Removal



1. Remove 4 screws holding the bottom cover.
2. Remove one screw from Main PCB Assembly. Take out the deck assembly.

3-1-5 Main Assembly Removal

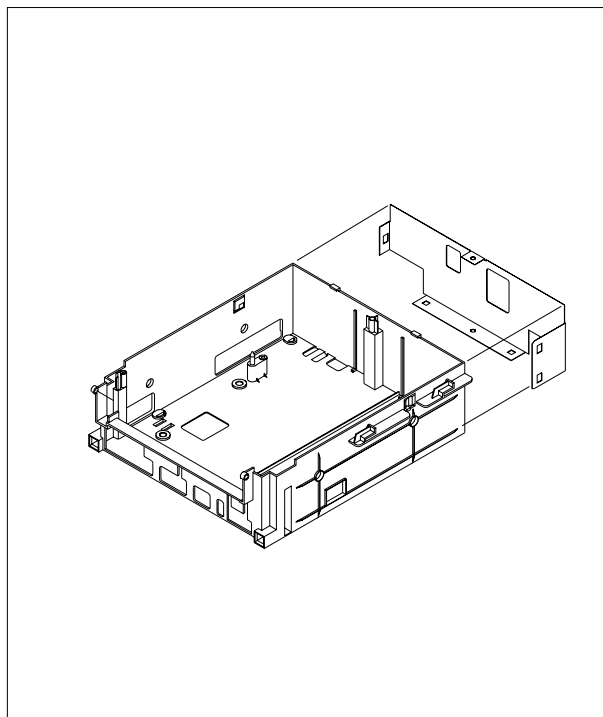

1. Remove 2 screws holding the upper chassis housing.
2. Remove 3 screws holding the deck assembly.
3. Lift the deck assembly upward to remove.

4. Alignments and Adjustments (Mechanical)

4-1 Deck Parts Locations

4-1-1 Deck (Top View)

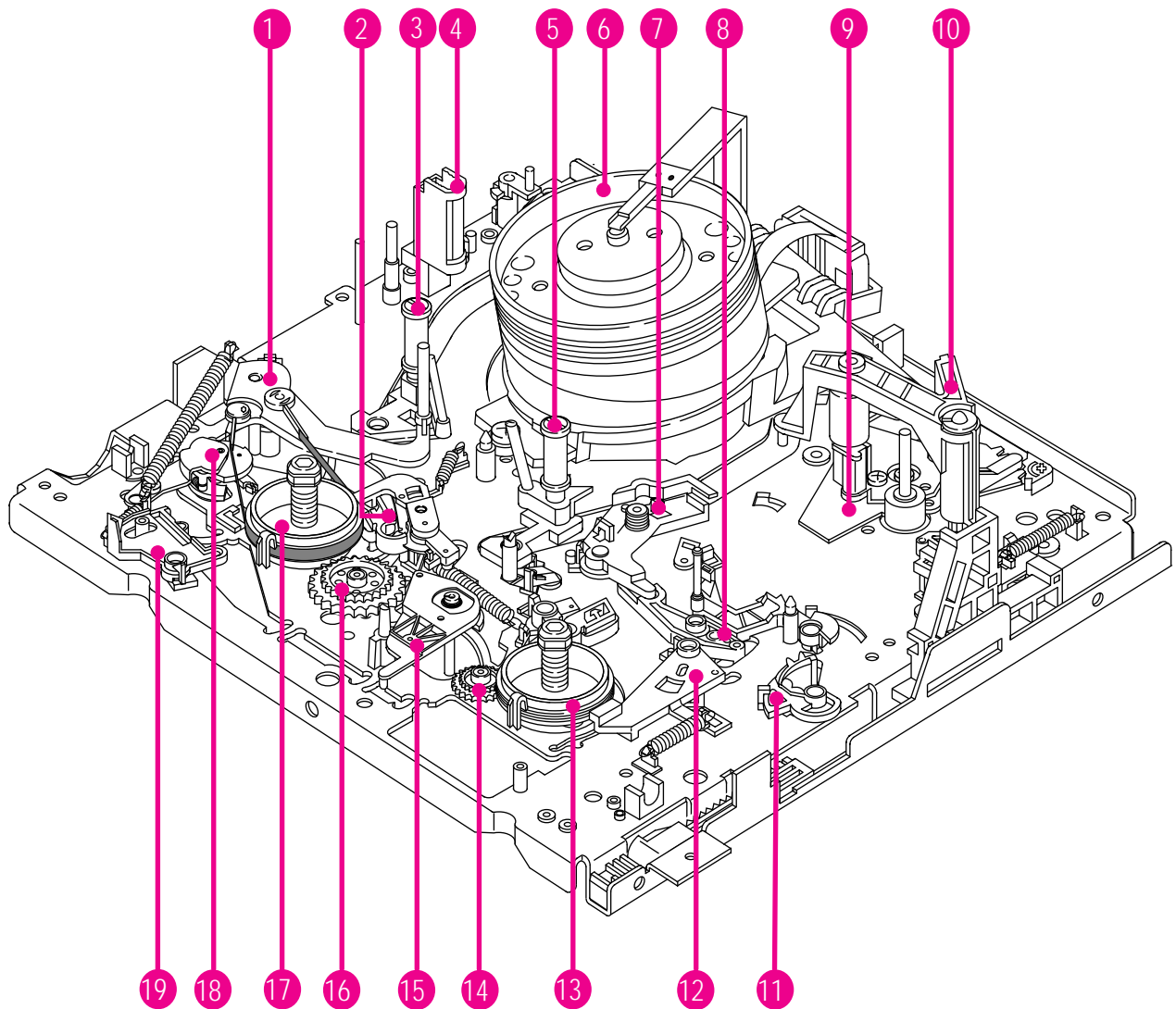

Fig.4-1 Deck Top Parts Location (DX7-A/DX8-A DECK ONLY)

1. ARM TENSION FULL ASS'Y
2. BRAKE MAIN "L" ASS'Y
3. GUIDE ROLLER ASS'Y "T"
4. FULL ERASE HEAD
5. GUIDE ROLLER ASS'Y "S"
6. CYLINDER ASS'Y
7. LEVER PINCH COMP ASS'Y
8. LEVER PINCH CAM

9. FULL ACE HEAD ASS'Y
10. UNIT PINCH ROLLER ASS'Y
11. LEVER REVIEW
12. BRAKE SUB "R" ASS'Y
13. REEL DISK "R" ASS'Y
14. GEAR RELAY "T" ASS'Y
15. IDLER ASS'Y
16. GEAR RELAY "S" ASS'Y

17. REEL DISK "L" ASS'Y
18. LEVER JOG ASS'Y
(DX8-A/AC ONLY)
19. LEVER REC SWITCH

4-1-2 Deck (Top View)

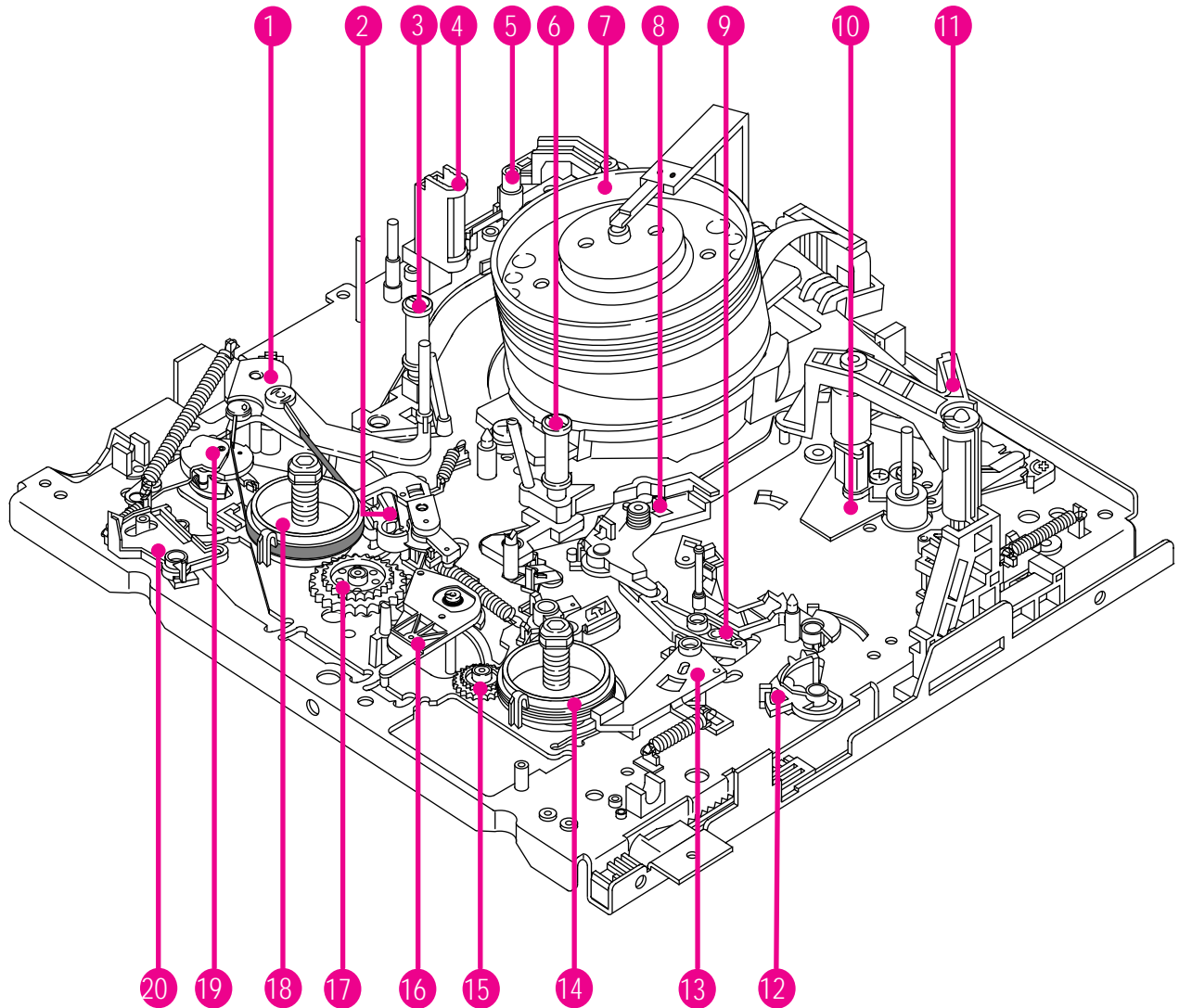

Fig.4-2 Deck Top Parts Location (DX7-AC/DX8-AC DECK ONLY)

- | | | |
|---|-----------------------------|--------------------------|
| 1. ARM TENSION FULL ASS'Y | 8. LEVER PINCH COMP ASS'Y | 16. IDLER ASS'Y |
| 2. BRAKE MAIN "L" ASS'Y | 9. LEVER PINCH CAM | 17. GEAR RELAY "S" ASS'Y |
| 3. GUIDE ROLLER ASS'Y "T" | 10. FULL ACE HEAD AAS'Y | 18. REEL DISK "L" ASS'Y |
| 4. FULL ERASE HEAD | 11. UNIT PINCH ROLLER ASS'Y | 19. LEVER JOG ASS'Y |
| 5. HEAD CLEANER ASS'Y
(DX7-AC/DX8-AC ONLY) | 12. LEVER REVIEW | (DX8-A/AC ONLY) |
| 6. GUIDE ROLLER ASS'Y "S" | 13. BRAKE SUB "R" ASS'Y | 20. LEVER REC SWITCH |
| 7. CYLINDER ASS'Y | 14. REEL DISK "R" ASS'Y | |
| | 15. GEAR RELAY "T" ASS'Y | |

4-1-3 Deck (Bottom View)

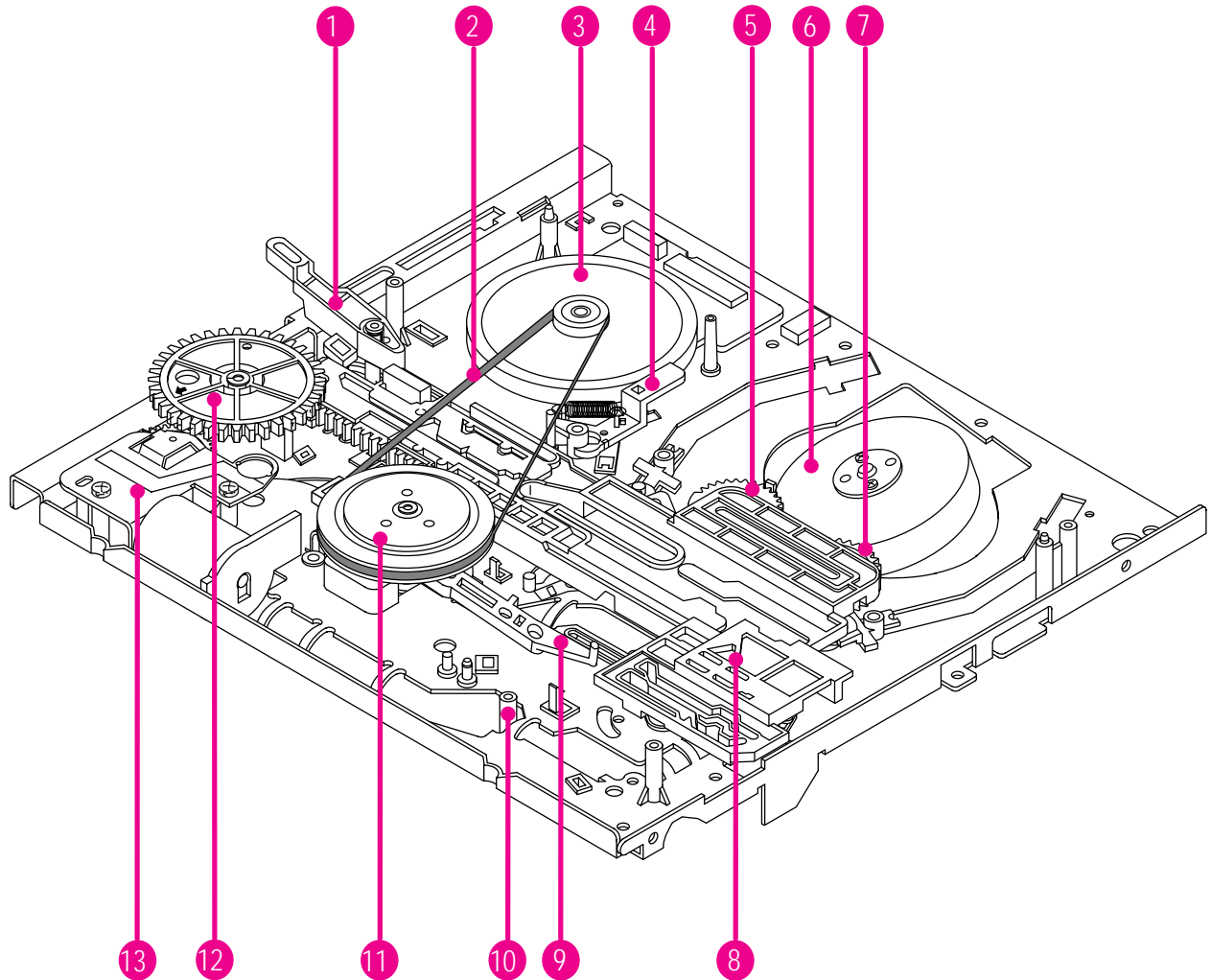

Fig.4-3 Deck Bottom Parts Location

- | | |
|---------------------------|------------------------|
| 1. LEVER SLIDE PINCH | 8. SLIDE MAIN |
| 2. BELT CAPSTAN | 9. LEVER REC SWITCH |
| 3. MOTOR D.D CAPSTAN | 10. LEVER IDLER CHANGE |
| 4. BRAKE CAPSTAN ASS'Y | 11. CLUTCH ASS'Y |
| 5. GEAR LOADING "R" ASS'Y | 12. UNIT LOADING |
| 6. MOTOR CYLINDER | 13. GEAR MASTER |
| 7. GEAR LOADING "L" ASS'Y | |

4-1-4 Housing View

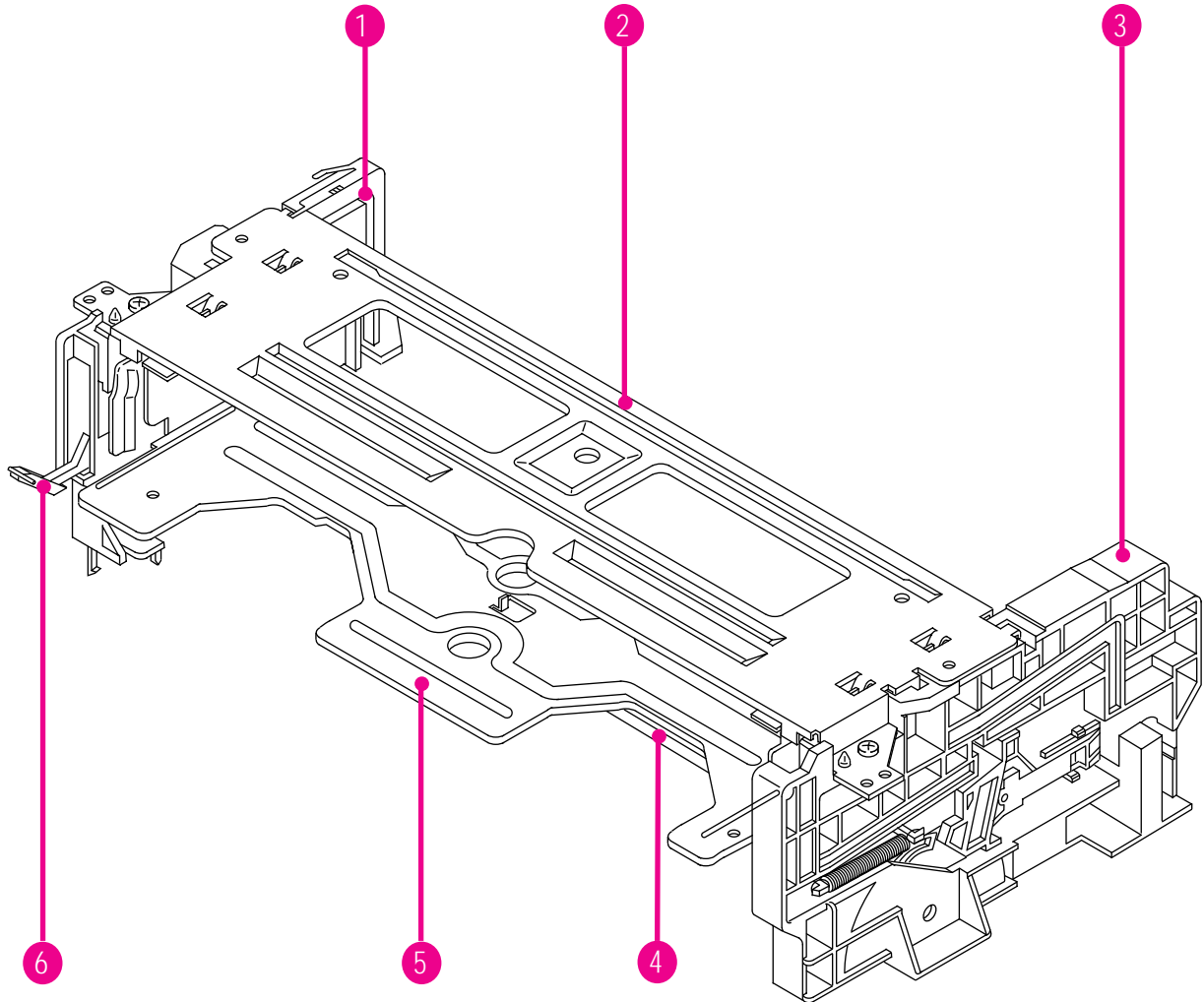

Fig. 4-4 Housing Parts Location

1. CHASSIS SIDE "L" ASS'Y
2. UPPER CHASSIS
3. CHASSIS SIDE "R" ASS'Y
4. SHAFT ARM ASS'Y
5. HOLDER CASSETTE ASS'Y
6. LEVER DOOR

4-2 Housing Assembly

4-2-1 Removal from Main Base

1. Remove 3 Screws ① .
2. Lift the Housing Ass'y in the direction of arrow "B", while pushing the tab ② in the direction of arrow "A". (Refer to detail drawing)

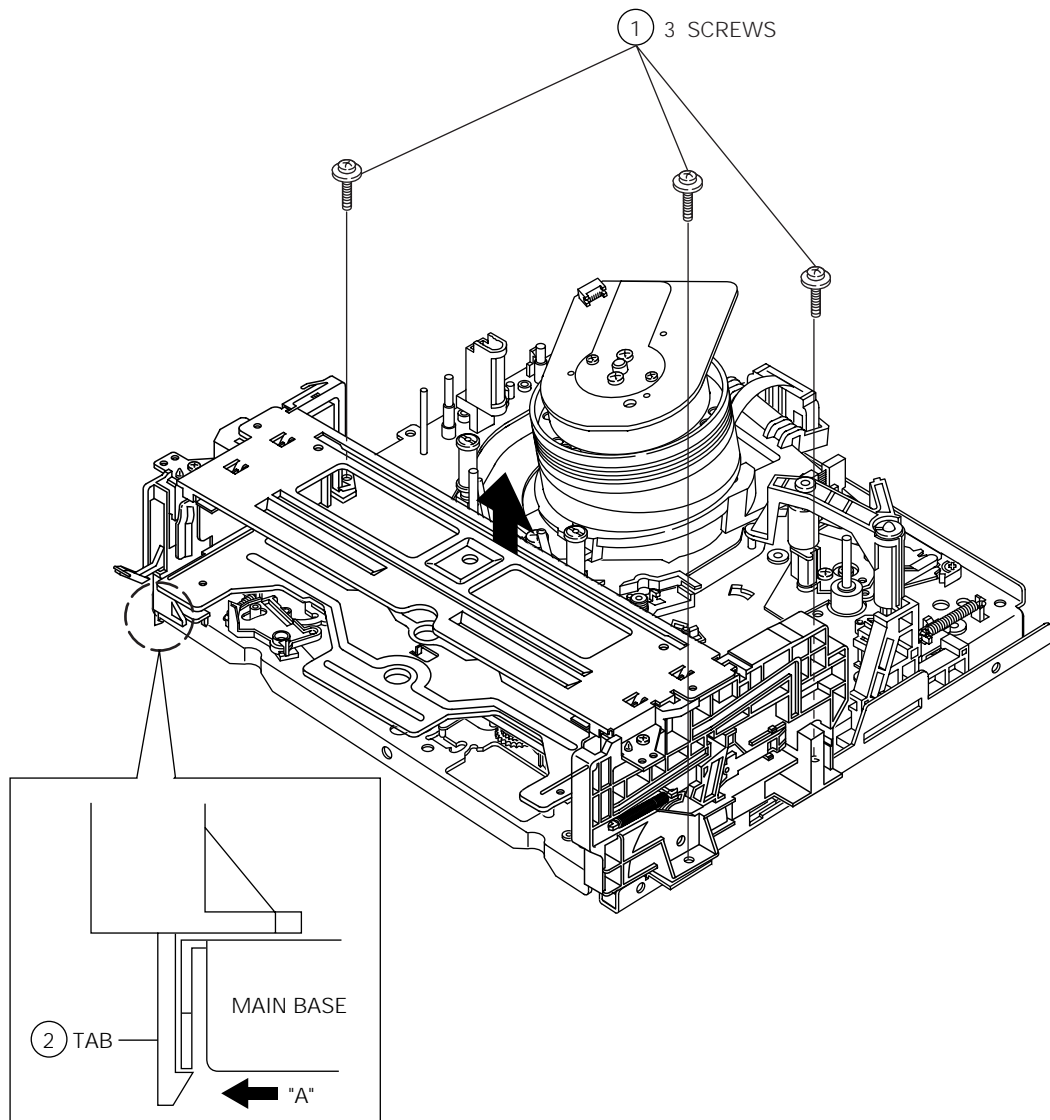

Fig. 4-5 Housing Ass'y Removal from Main Base

4-2-2 Disassembly

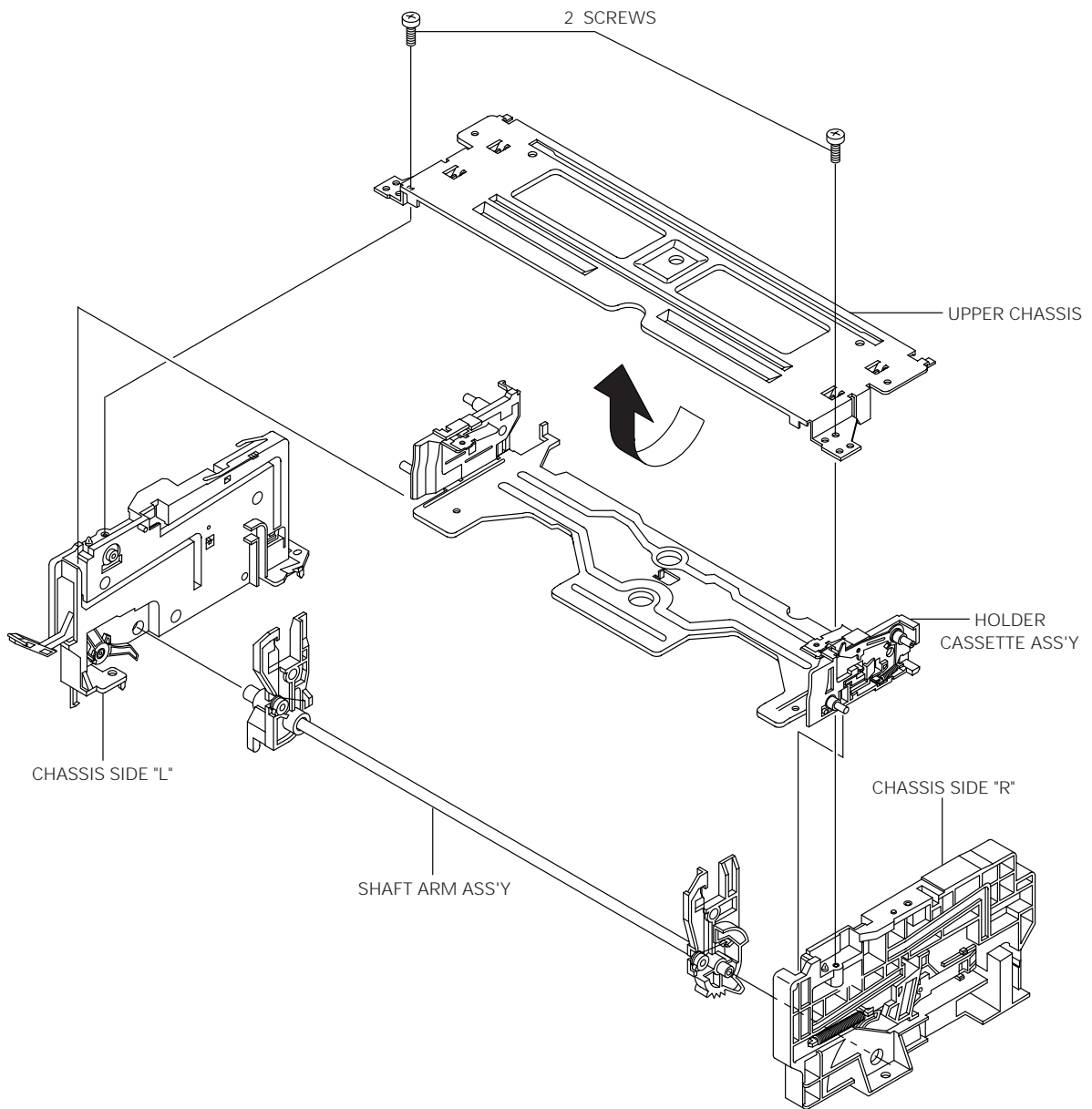

Fig. 4-6 Housing Ass'y Removal

4-2-3 Upper Chassis Removal

1. Remove 2 Screws ①.
2. Lift the Upper Chassis ② in the direction of arrow "A".

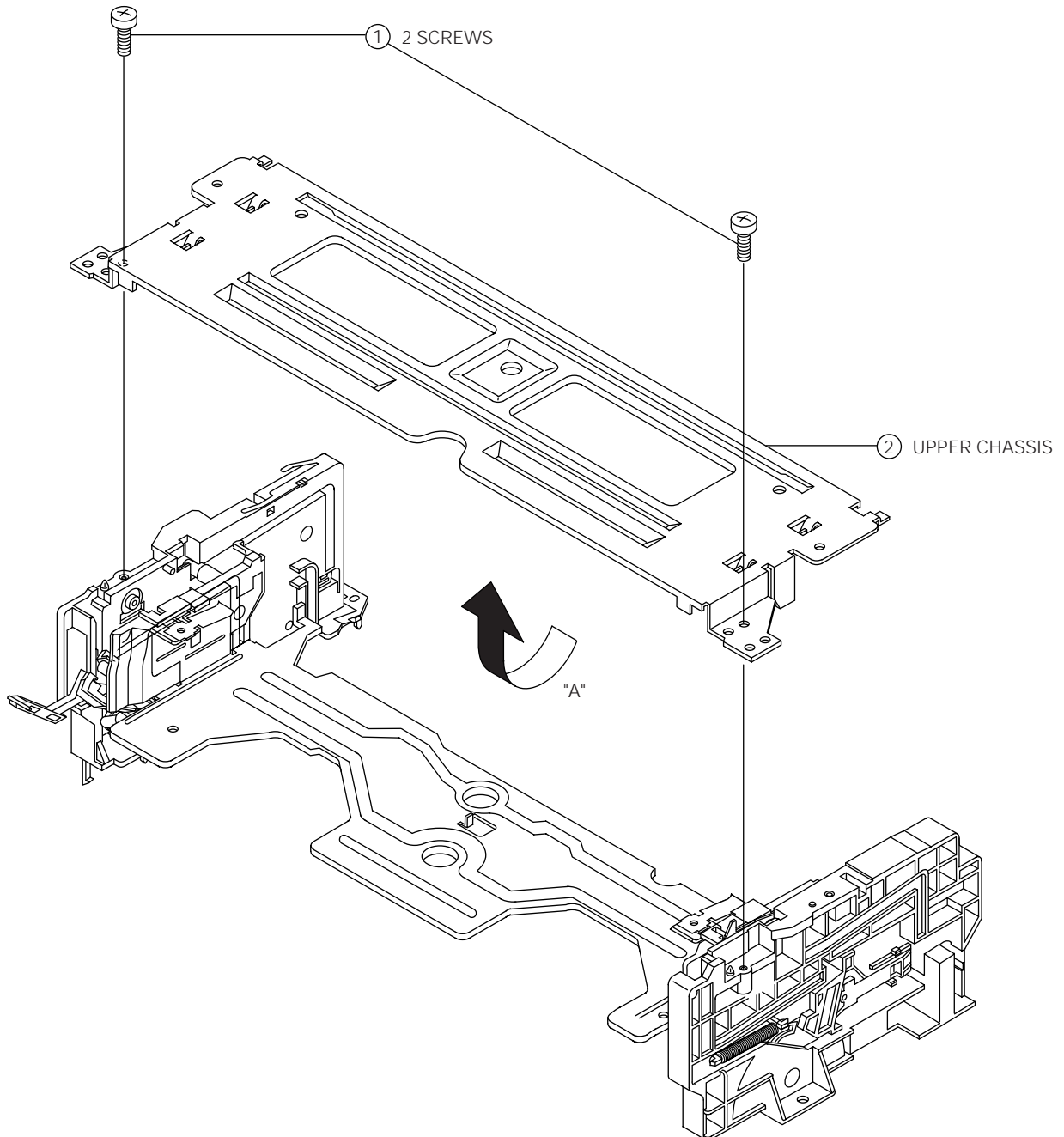

Fig. 4-7 Upper Chassis Removal

4-2-4 Holder Cassette Ass'y and Chassis Side L/R Removal

1. Lift the Cassette Holder ① in the direction of arrow "A" (Refer to Fig. A).
2. Remove the Side Chassis "L" ② and "R" ③ from Arm Shaft Ass'y ④ in the direction of arrow "B", "C" (Refer to Fig. B).

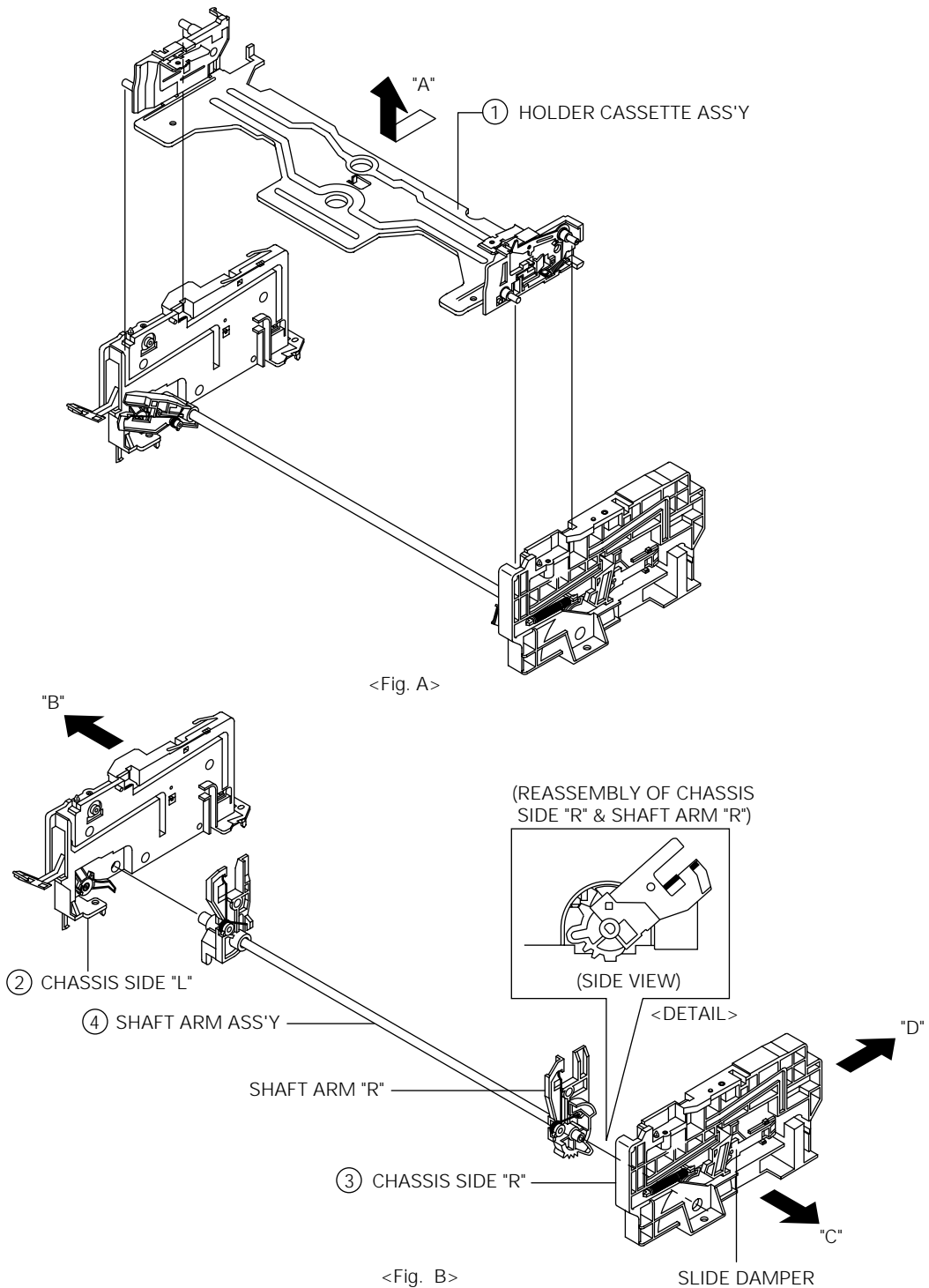

Fig. 4-8 Holder Cassette Ass'y and Chassis Side L/R

4-2-5 Chassis Side "R" Parts Locations

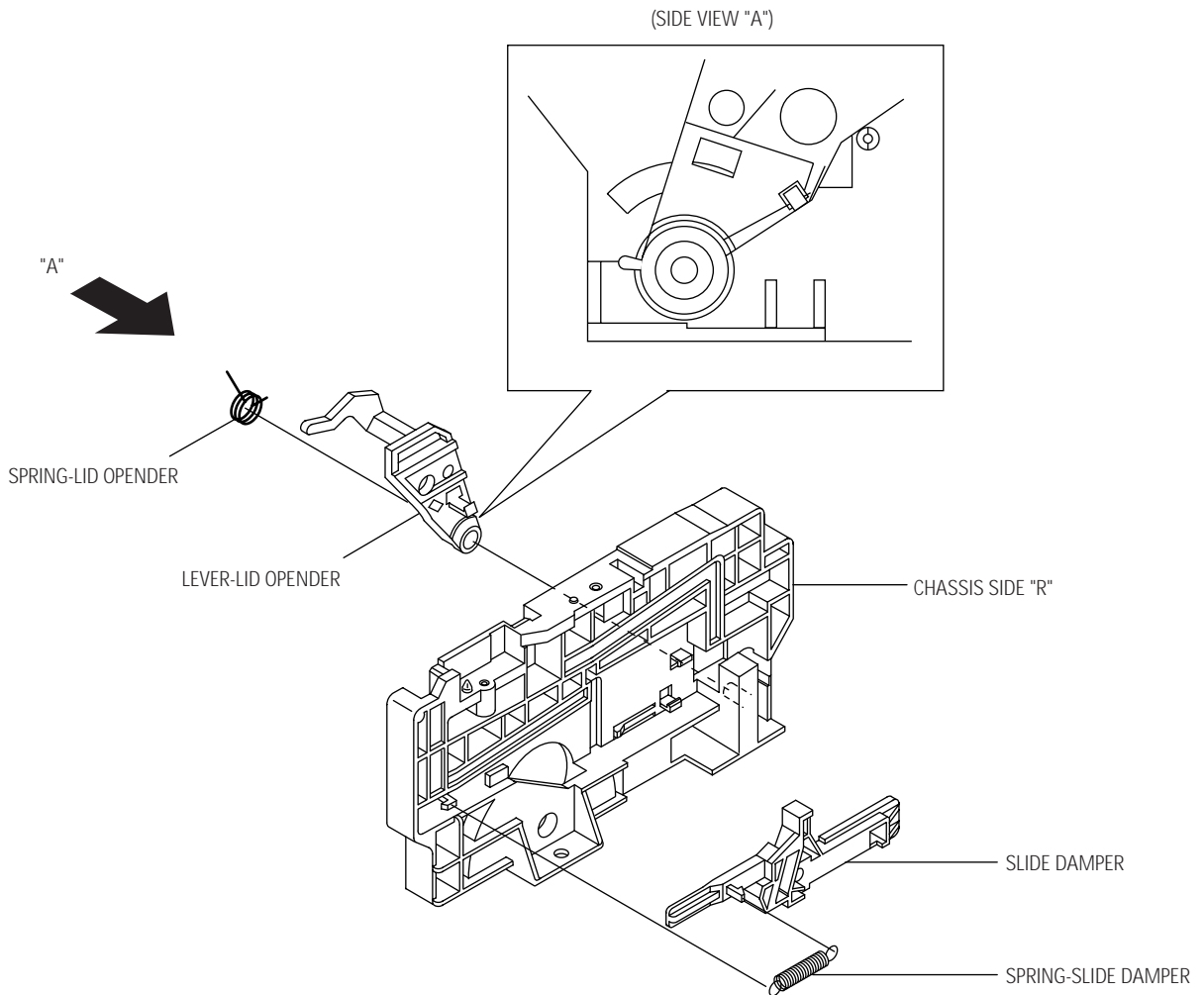

Fig. 4-9 Chassis Side "R" Parts Locations

Note : If you operate the deck when the Cassette Ass'y Holder is removed, the Arm Shaft "R" and the Damper Slide are not returned to their original positions. If this happens by accident, push the Damper Slide of Side Chassis "R" in the direction of arrow "D", and return the Damper Slide in the reverse direction of arrow "D" when the Arm Shaft Ass'y is in eject mode.

4-2-6 Slide Damper Removal

1. Remove the Slide Damper Spring ①.
2. Push the Stopper ③ of the Side Chassis "R" ④. Move the Damper Slide ② in the direction of arrow.
3. Align the Damper Slide with the chassis side tab (as shown detail drawing).

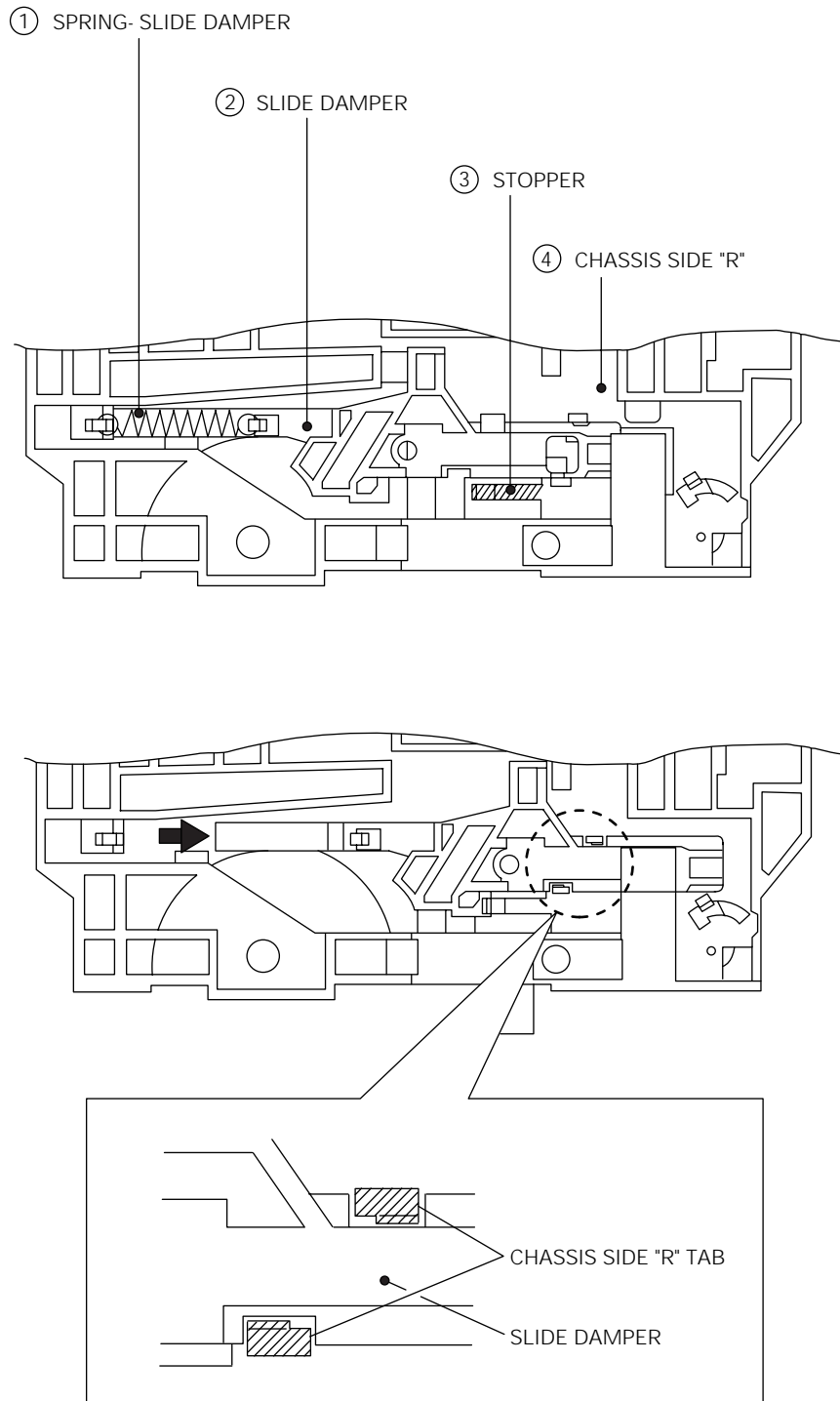

Fig. 4-10 Slide Damper Removal

4-3 Cylinder Ass'y

4-3-1 Exploded View of Cylinder Ass'y

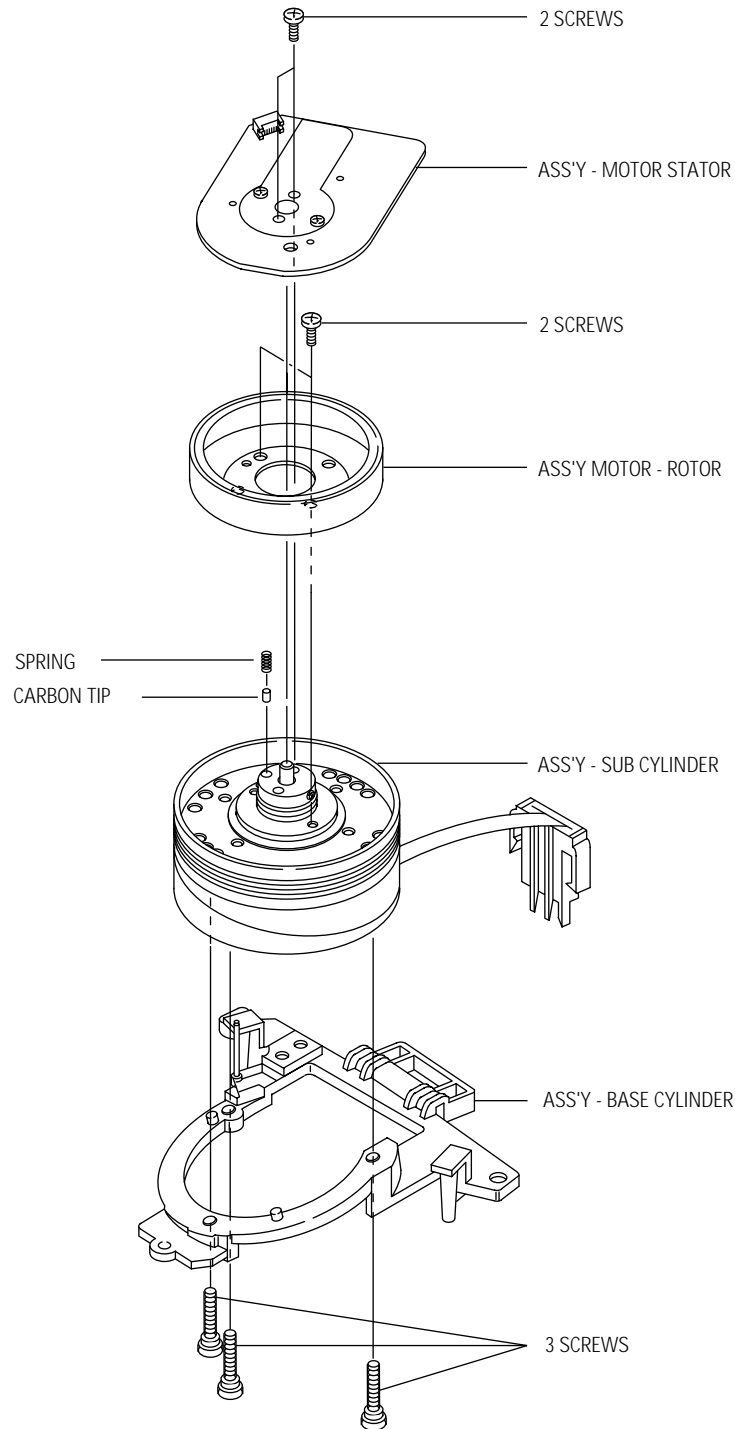

Fig. 4-11 Exploded View of Cylinder Ass'y

4-3-2 Head Cleaner Ass'y Removal (Only for Deck : DX7-AC/DX8-AC)

1. Release 1 tab ① in the direction of arrow "A". (Refer to detail drawing)
2. Lift the Head Cleaner ② in the direction of arrow "B".

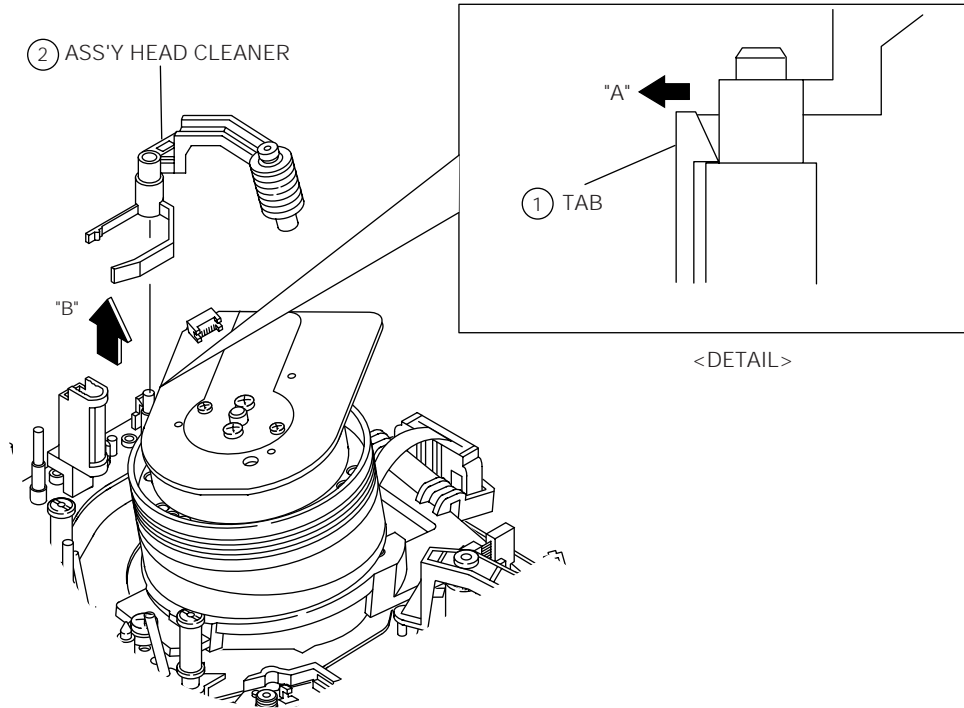

Fig. 4-12 Head Cleaner Ass'y Removal

4-3-3 Cylinder Ass'y Removal from Main Base

1. Remove 3 Screws ① holding the Main Base and the Cylinder Ass'y.
2. Lift the Cylinder Ass'y ② in the direction of arrow.

Note : Do not touch the video heads during removal or installation.

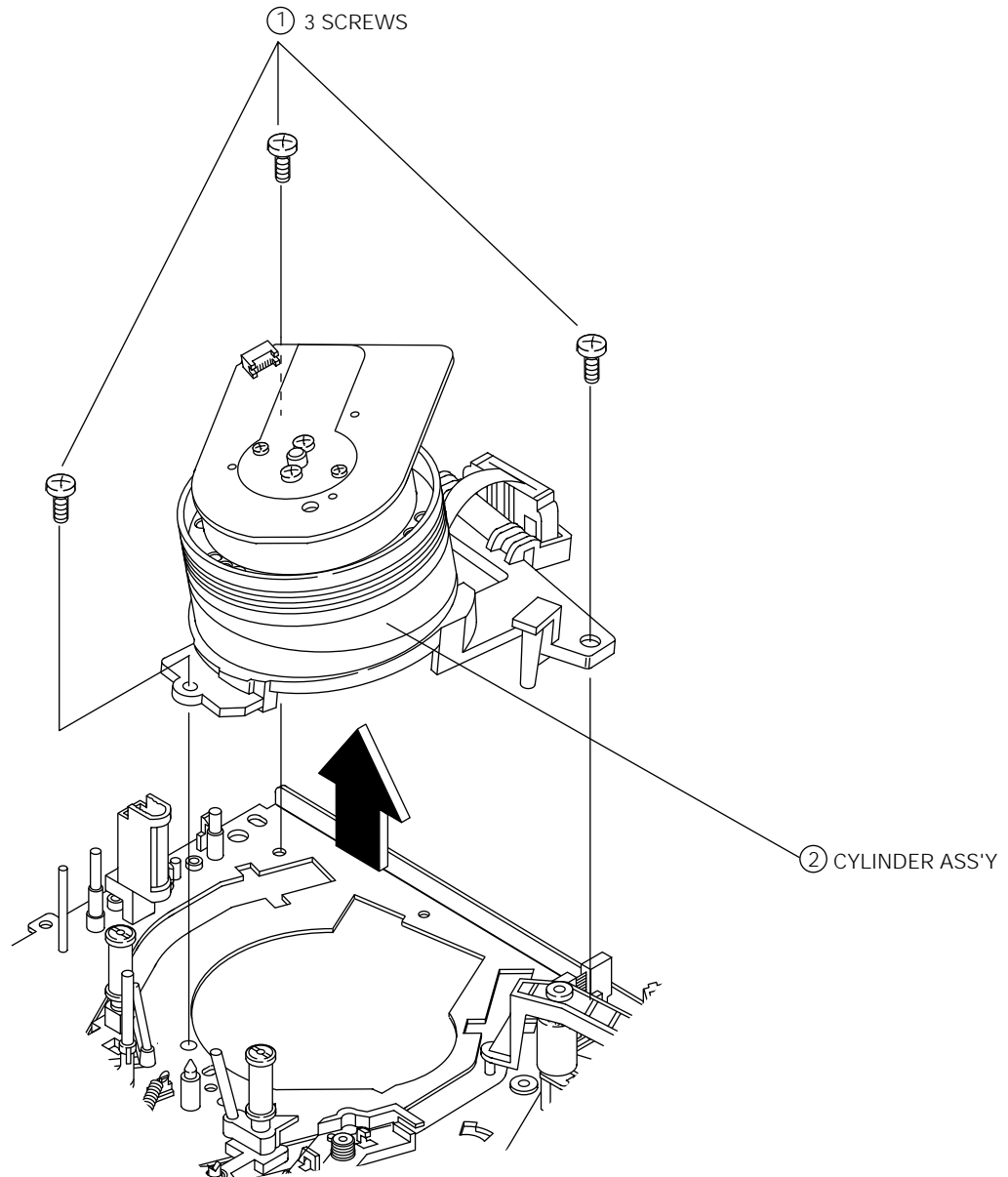

Fig. 4-13 Cylinder Ass'y Removal from Main Base

4-3-4 Holder FPC Removal

1. Release the Holder FPC tab holding the Cylinder Base ② in the direction of arrow.
(Refer to detail drawing)
2. Disconnect the Holder FPC ① from the Cylinder Base ②.
3. Note : When disconnecting the FPC Holder ① from the Cylinder Base ② :
Take care not to disconnect the FPC cable from the FPC Holder (The FPC cable is very short).

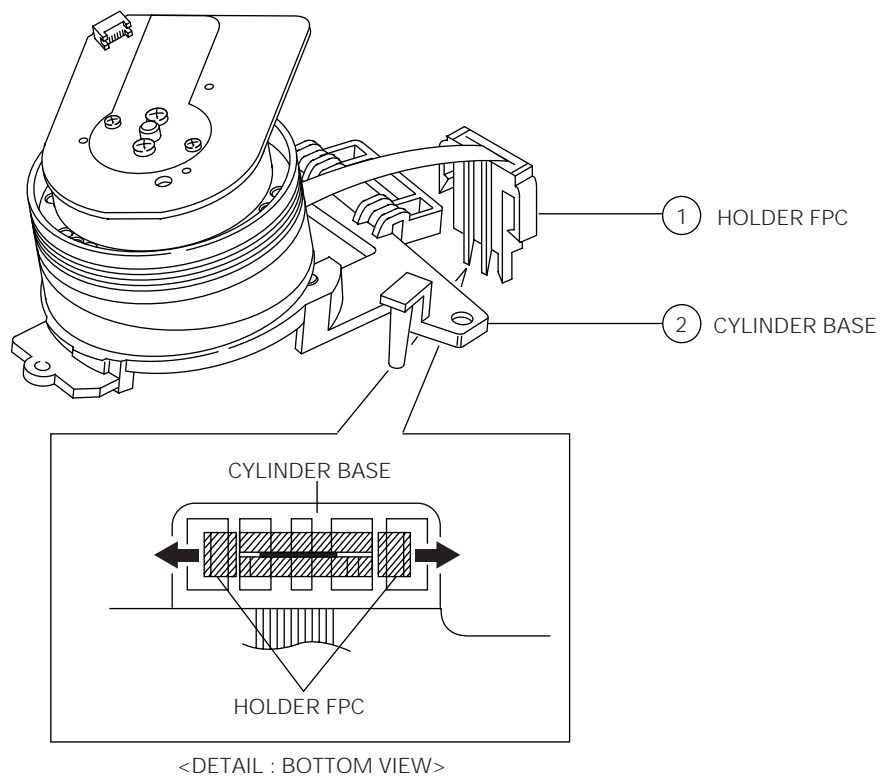

Fig. 4-14 Head Brush and Holder FPC Removal

4-3-5 Cylinder Ass'y Removal from Cylinder Base

1. Remove 3 Screws ① from the Cylinder Base ②.
2. Lift the Cylinder Ass'y ③ from the Cylinder Base ② in the direction of arrow.

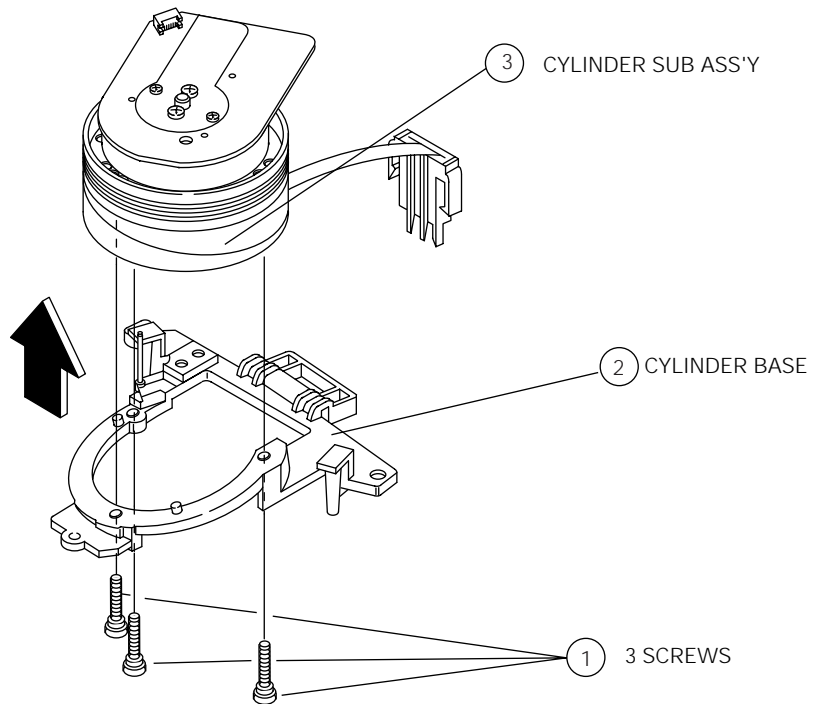

Fig. 4-15 Cylinder Ass'y Removal from Cylinder Base

4-3-6 Motor Stator Removal

1. Remove 2 Screws ①.
2. Remove the Motor Stator ② from the Cylinder Sub Ass'y ⑤.
3. Note : When disassembling the Motor-Stator, be careful not to loose the carbon-tip and spring.

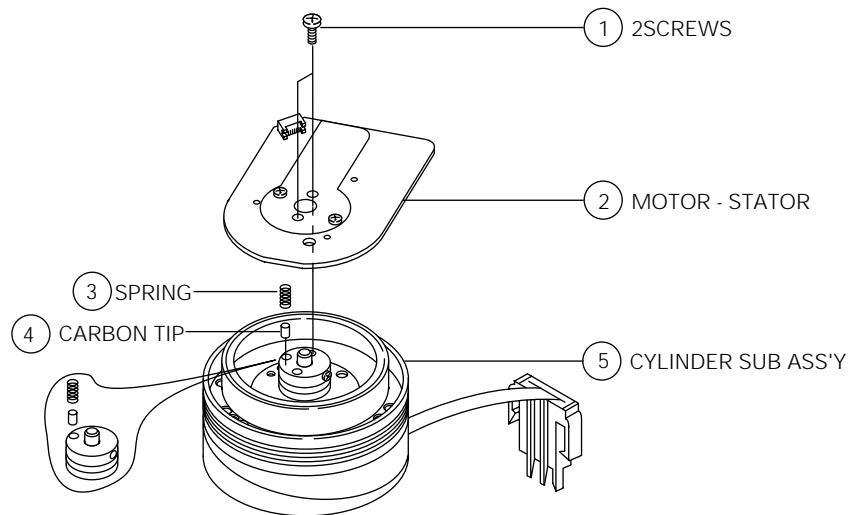

Fig. 4-16 Motor Stator Removal

4-3-7 Motor Rotor Removal

1. Remove 2 Screws ①.
2. Lift The Motor Rotor②.

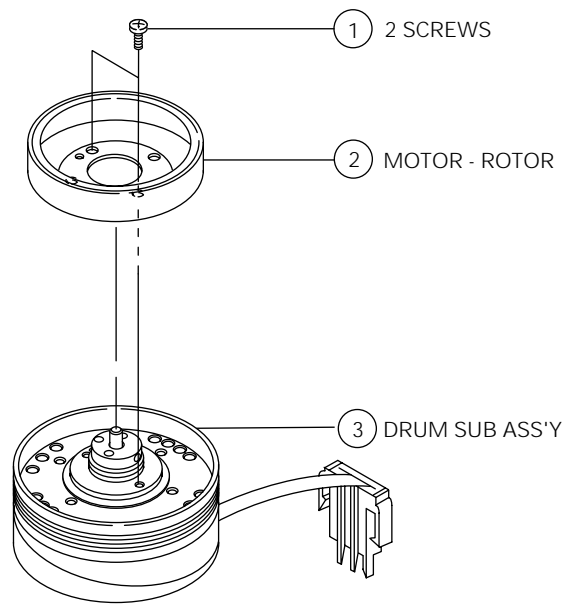

Fig. 4-17 Motor Rotor Removal

4-3-8 Motor Rotor and Cylinder Sub Ass'y

1. Make sure that phase matching holes of the Motor Rotor and the Cylinder Sub Ass'y are aligned correctly as shown in Fig. 4-18 (Refer to phase matching hole).
2. Secure 2 Screws.

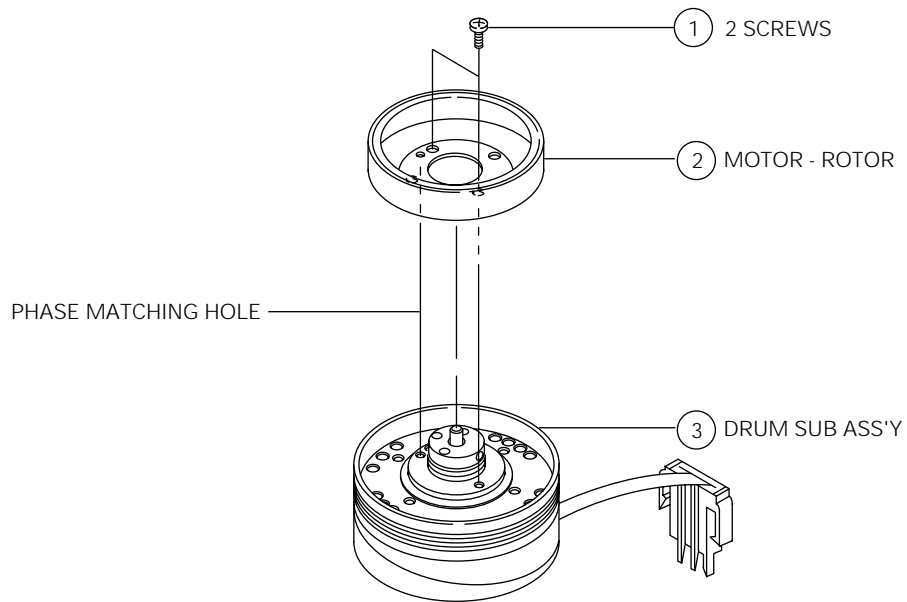

Fig. 4-18 Assembly of Motor Rotor and Cylinder Sub Ass'y

4-3-9 Motor Stator and Cylinder Sub Ass'y

1. Reinstall the Motor Stator ① toward the FPC cable of Cylinder Sub Ass'y ②.
2. Secure 2 Screws. (Refer to Fig. 4-16)

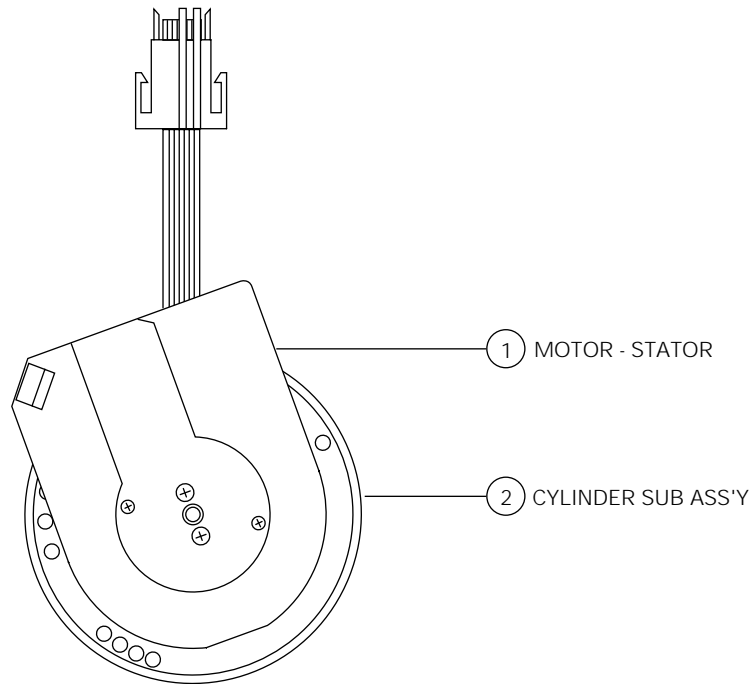

Fig. 4-19 Assembly of Motor Stator and Cylinder Sub Ass'y

4-4 Main Deck Removal and Reassembly

4-4-1 Slide Rack Housing Removal

1. Lift the Slide Rack Housing.

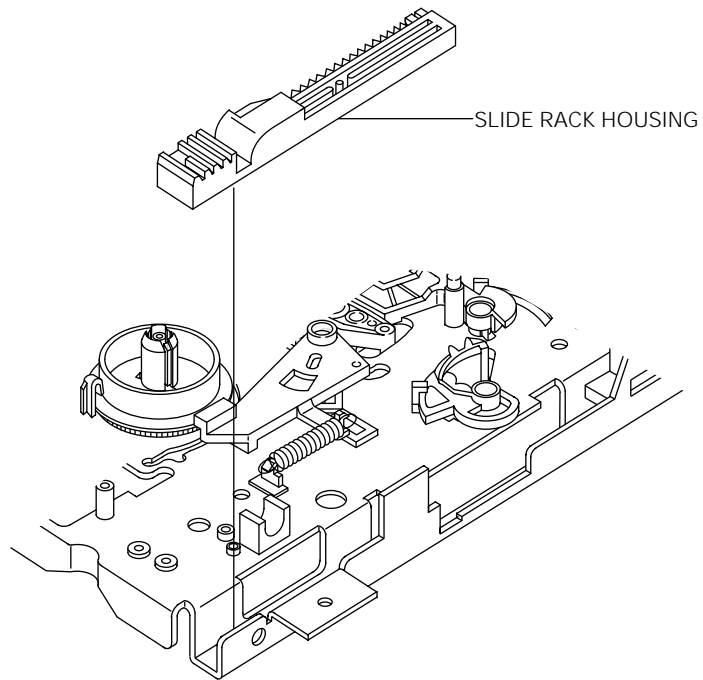

Fig. 4-20 Slide Rack Housing Removal

4-4-2 Assembly of Slide Rack Housing and Master Gear

1. Confirm that the hole of Master Gear ① and the hole "A" of Main Base are aligned correctly. (Eject mode)
2. Align the Slot #1 of Master Gear ① with the Tooth #1 of Rack Housing Slide ②. (Refer to timing point)

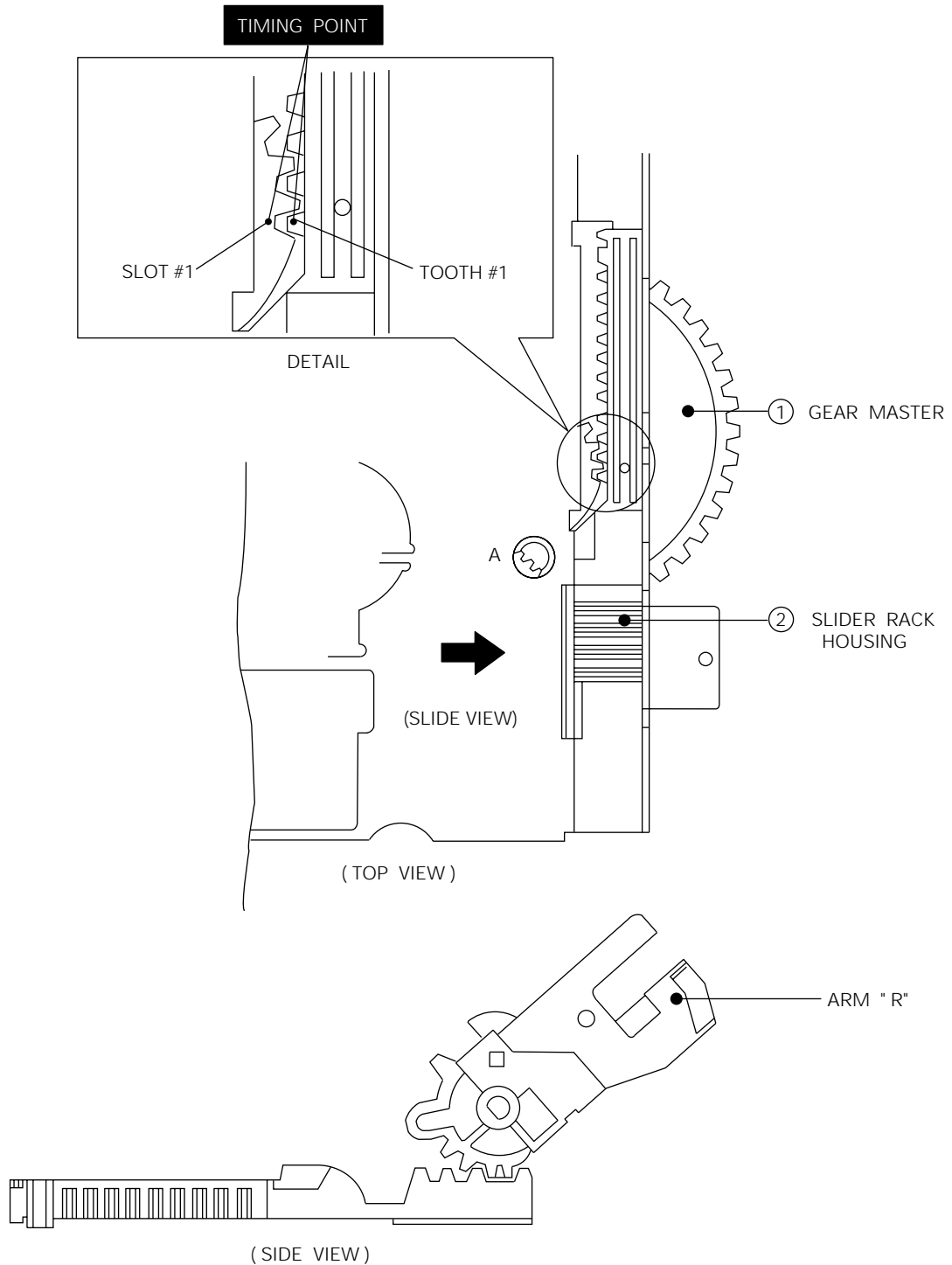

Fig. 4-21 Assembly of Slide Rack Housing and Gear Master

4-4-3 Brake Sub "L" Removal

1. Remove the Sub "L" Brake Spring ①.
2. Release the tab ② in the direction of arrow. (Refer to detail drawing)
3. Lift the Sub "L" Brake ③.

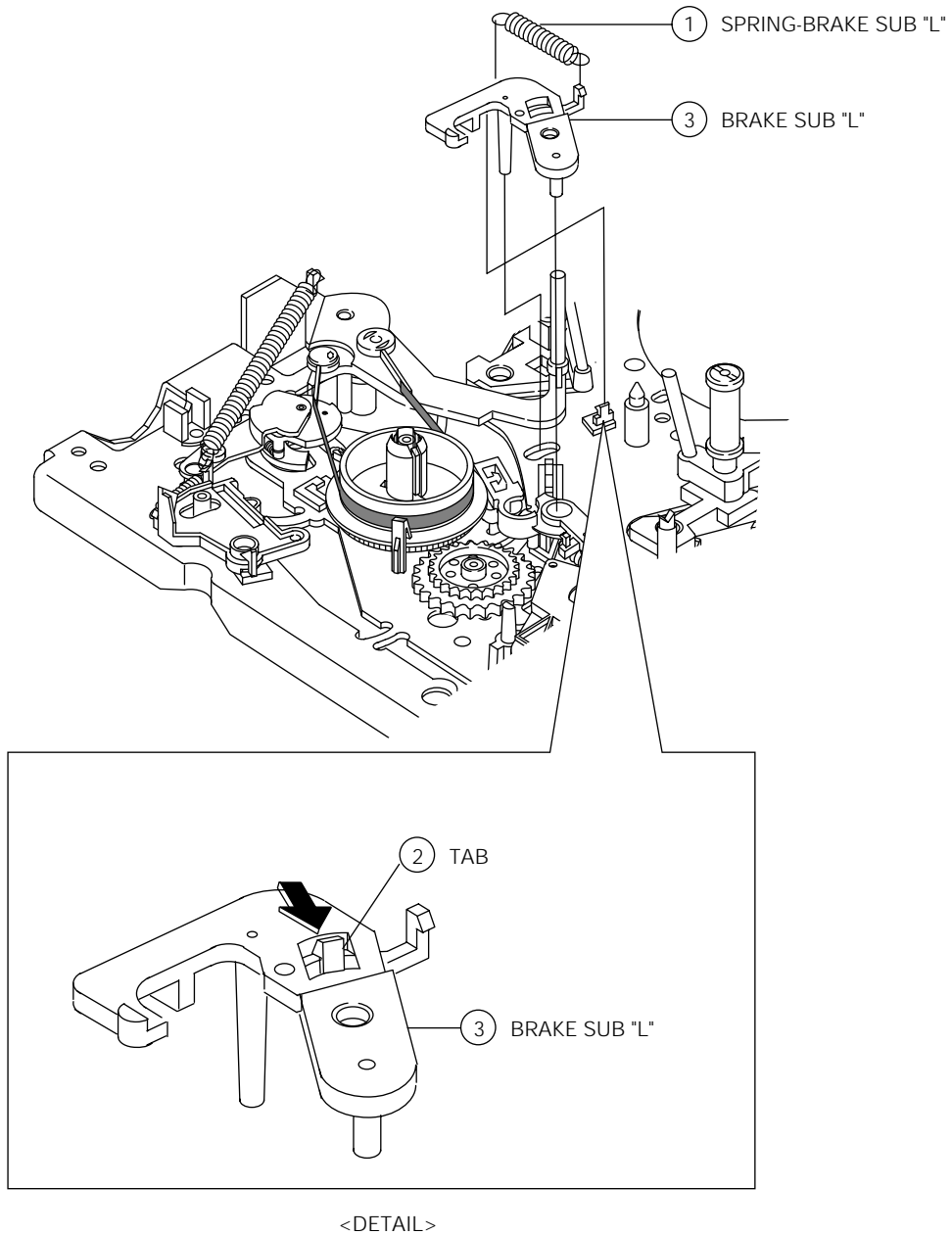
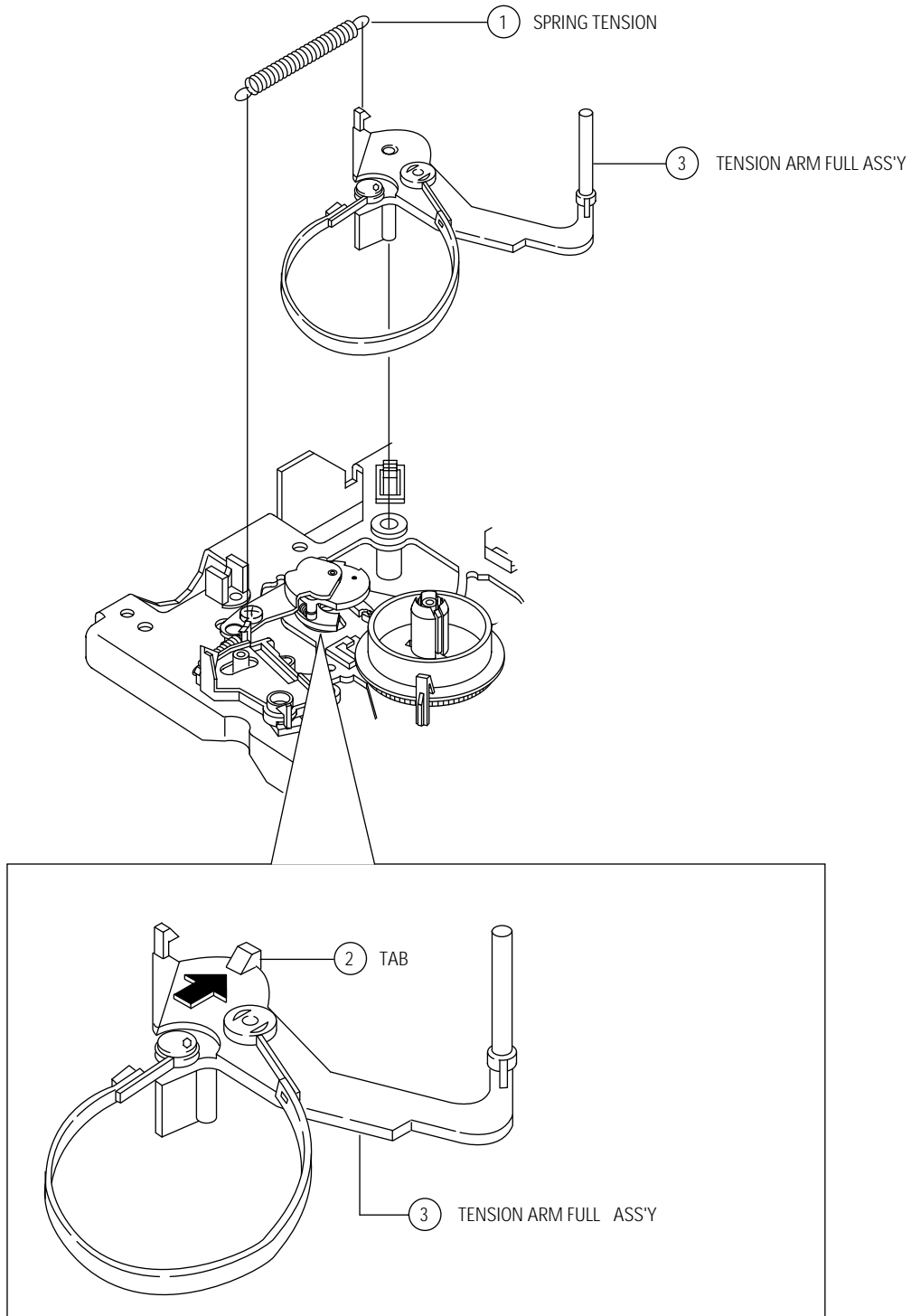

Fig. 4-22 Brake Sub "L" Removal

4-4-4 Tension Arm Full Ass'y Removal

1. Remove the Tension Spring ①.
2. Release the tab ② in the direction of arrow. (Refer to detail drawing)
3. Lift the Tension Arm Full Ass'y ③.



<DETAIL>

Fig. 4-23 Tension Arm Full Ass'y Removal

4-4-5 JOG LEVER Ass'y Removal (Only for deck : DX8-A/DX8-AC)

1. Remove the 1 Screw ①.
2. Lift the JOG Lever Ass'y ②.

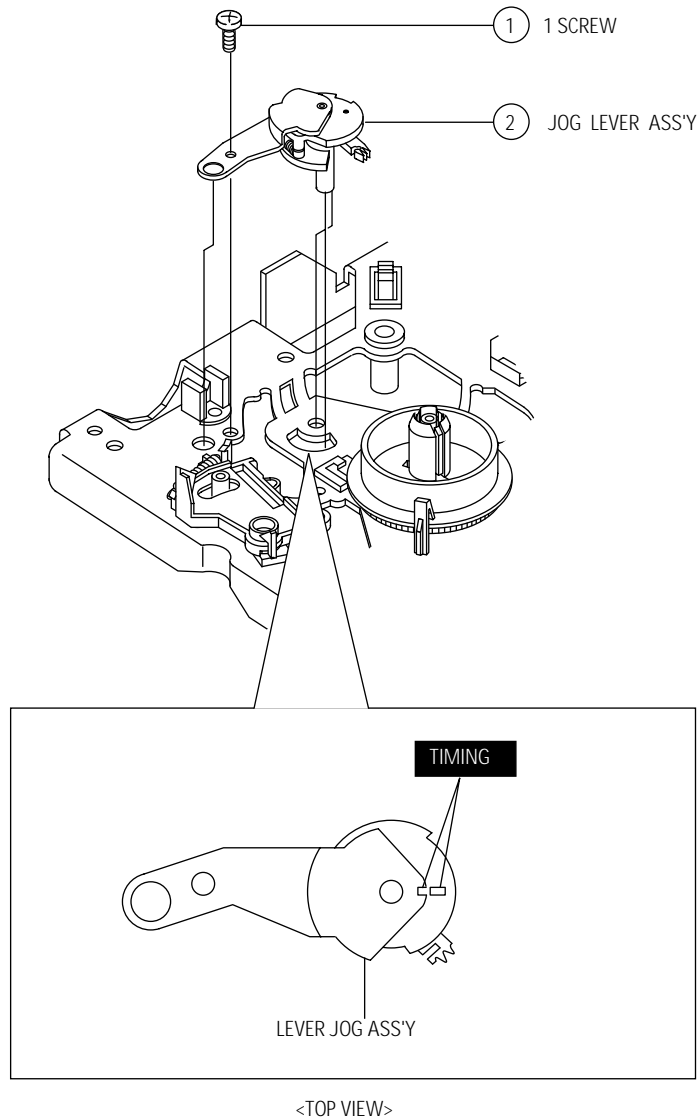
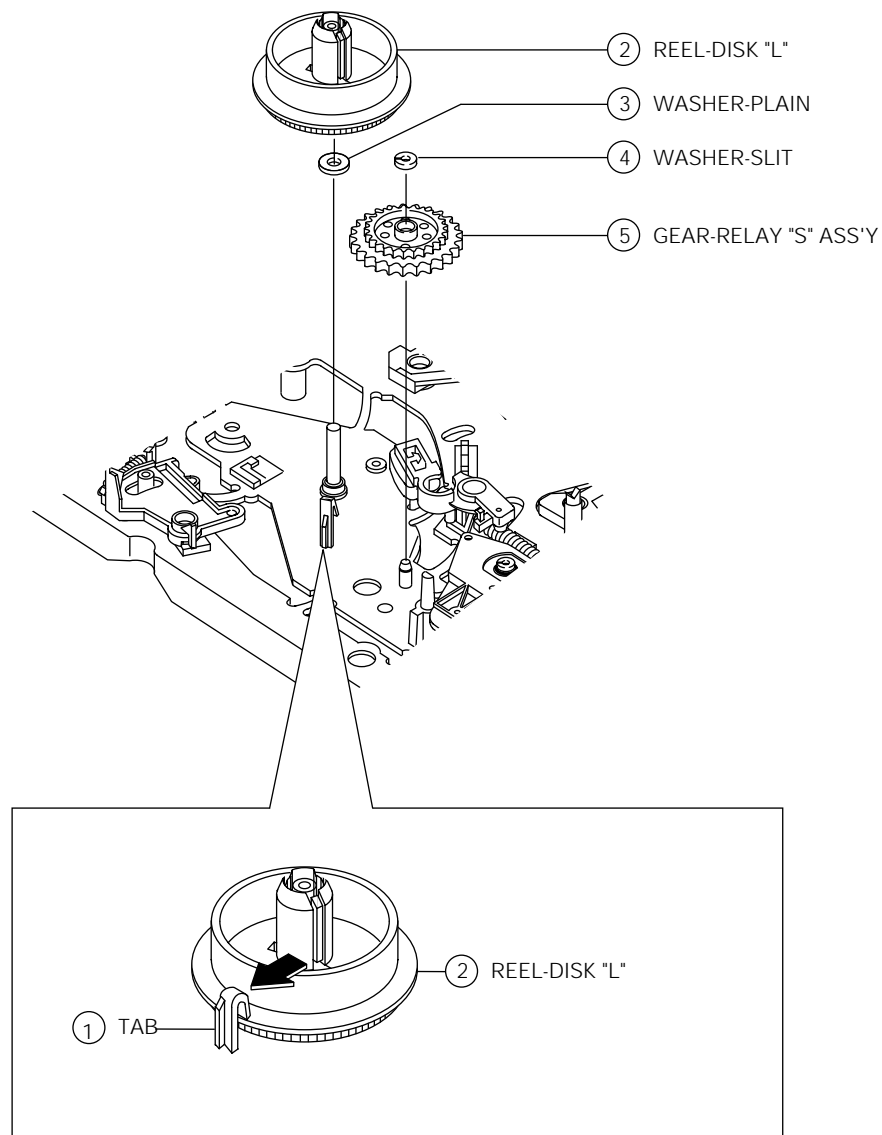

Fig. 4-24 JOG Lever Ass'y Removal

4-4-6 Relay Gear "S" and Reel Disk "L" Removal

1. Release the tab ① in the direction of arrow. (Refer to detail drawing)
2. Lift the Reel Disk "L" ②.
3. Remove the Plain Washer ③.
4. Remove the Slit Washer ④.
5. Lift the Relay "S" Gear Ass'y ⑤.
6. Note : When reinstalling, be sure to install the Reel Disk "L" ✕ after installing the Plain Washer.



<DETAIL>

Fig. 4-25 Reel Disk "L" and Gear Relay "S" Ass'y Removal

4-4-7 Sub Brake "R" Ass'y Removal

1. Remove the Sub "R" Brake Spring ①.
2. Release the tab ② in the direction of arrow. (Refer to detail drawing)
3. Lift the Brake Sub "R" Ass'y ③.

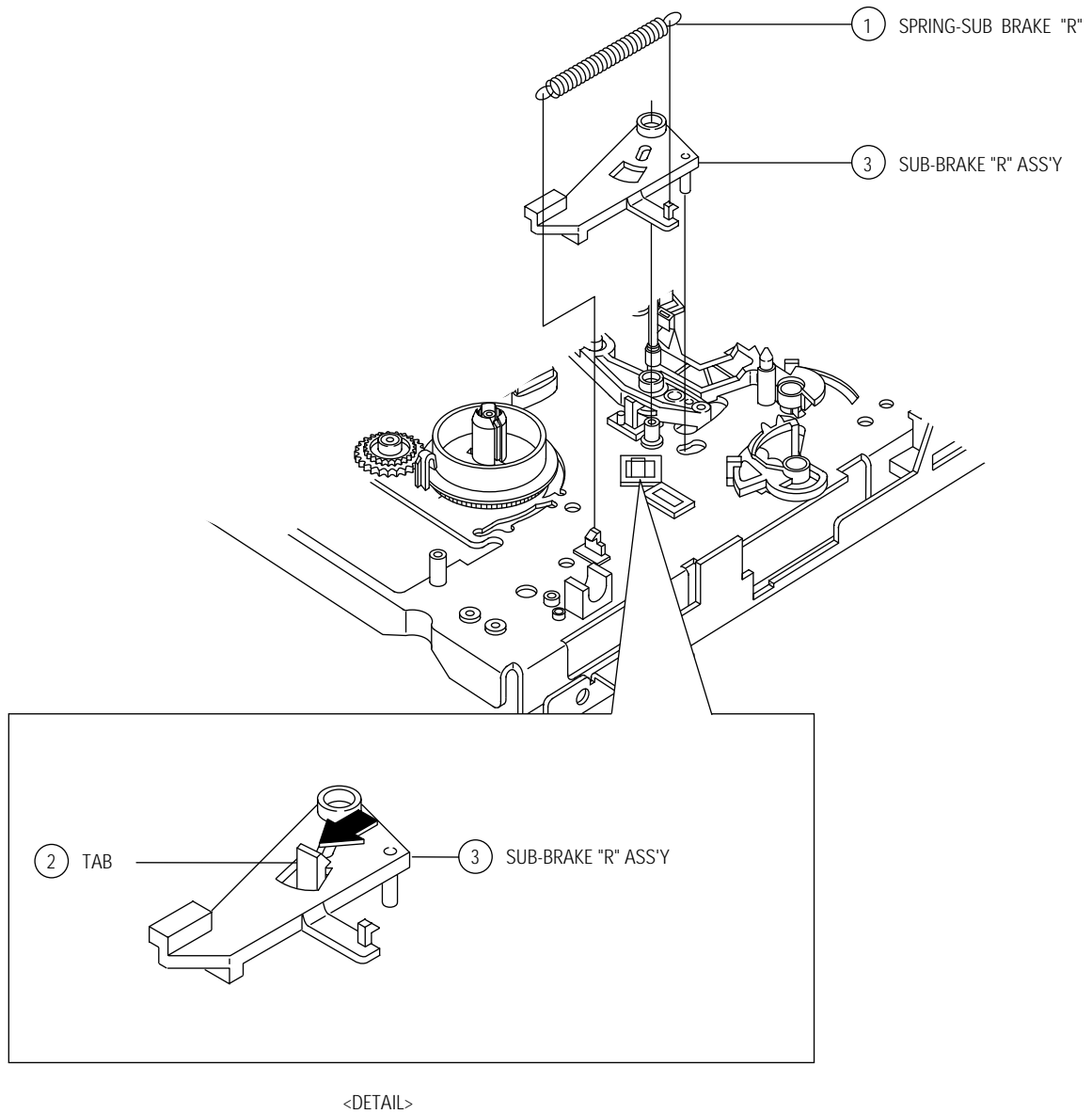

Fig. 4-26 Sub Brake "R" Ass'y Removal

4-4-8 Reel Disk "R" Ass'y and Relay "T" Gear Removal

1. Release the tab ① in the direction of arrow. (Refer to detail drawing)
2. Lift the Reel Disk "R" Ass'y ②.
3. Remove the Plain Washer ③.
4. Remove the Slit Washer ④.
5. Lift the Relay "T" Gear Ass'y ⑤.

Note : When reinstalling, be sure to install the Reel Disk "R" Ass'y ② after installing the Plain Washer ③.

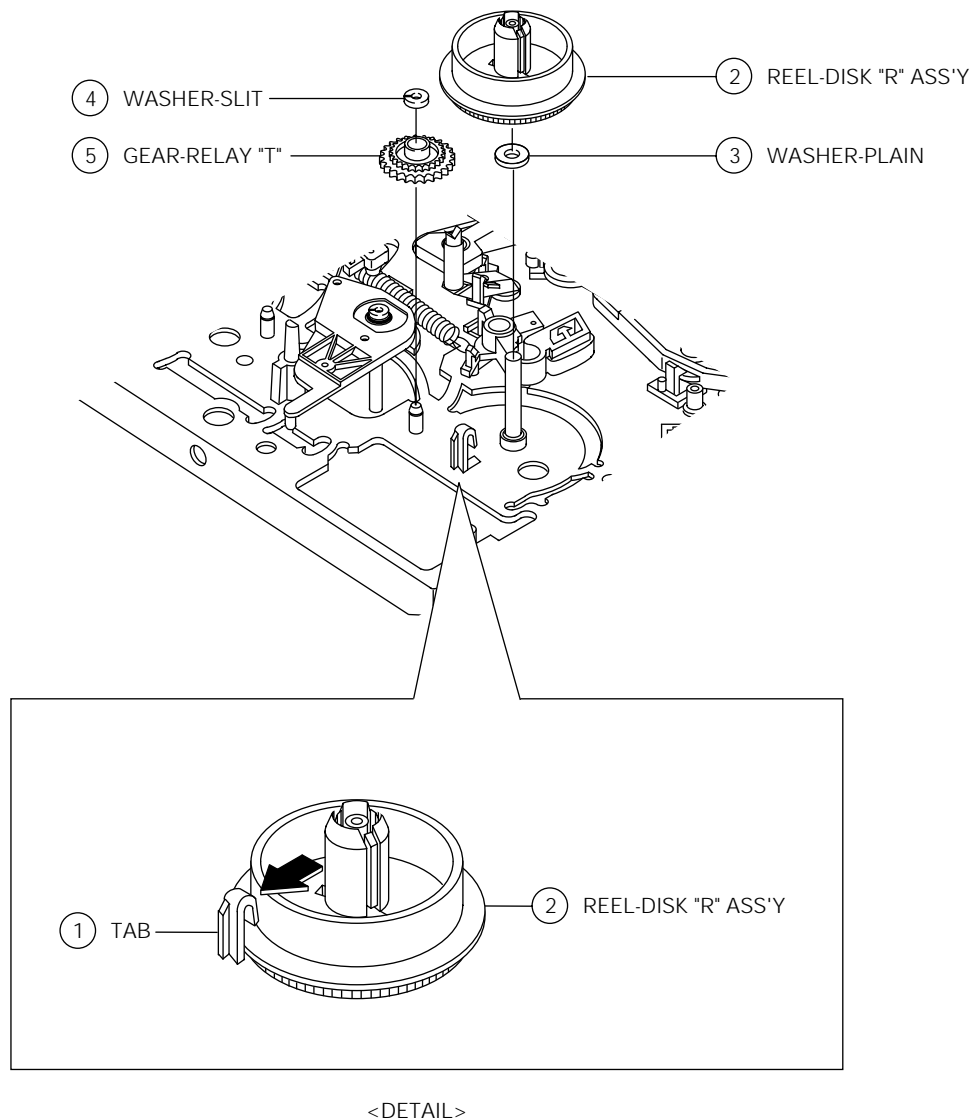

Fig. 4-27 Reel Disk "R" Ass'y and Gear Relay "T" Removal

4-4-9 Main Brake "L", "R" Ass'y Removal

1. Release the Main Brake Spring ①.
2. Release the tab ② in the direction of arrow "A". (Refer to detail drawing A)
3. Lift the Main Brake "L" ③.
4. Release the tab ④ in the direction of arrow "B". (Refer to detail drawing B)
5. Lift the Main "R" Brake ⑤.

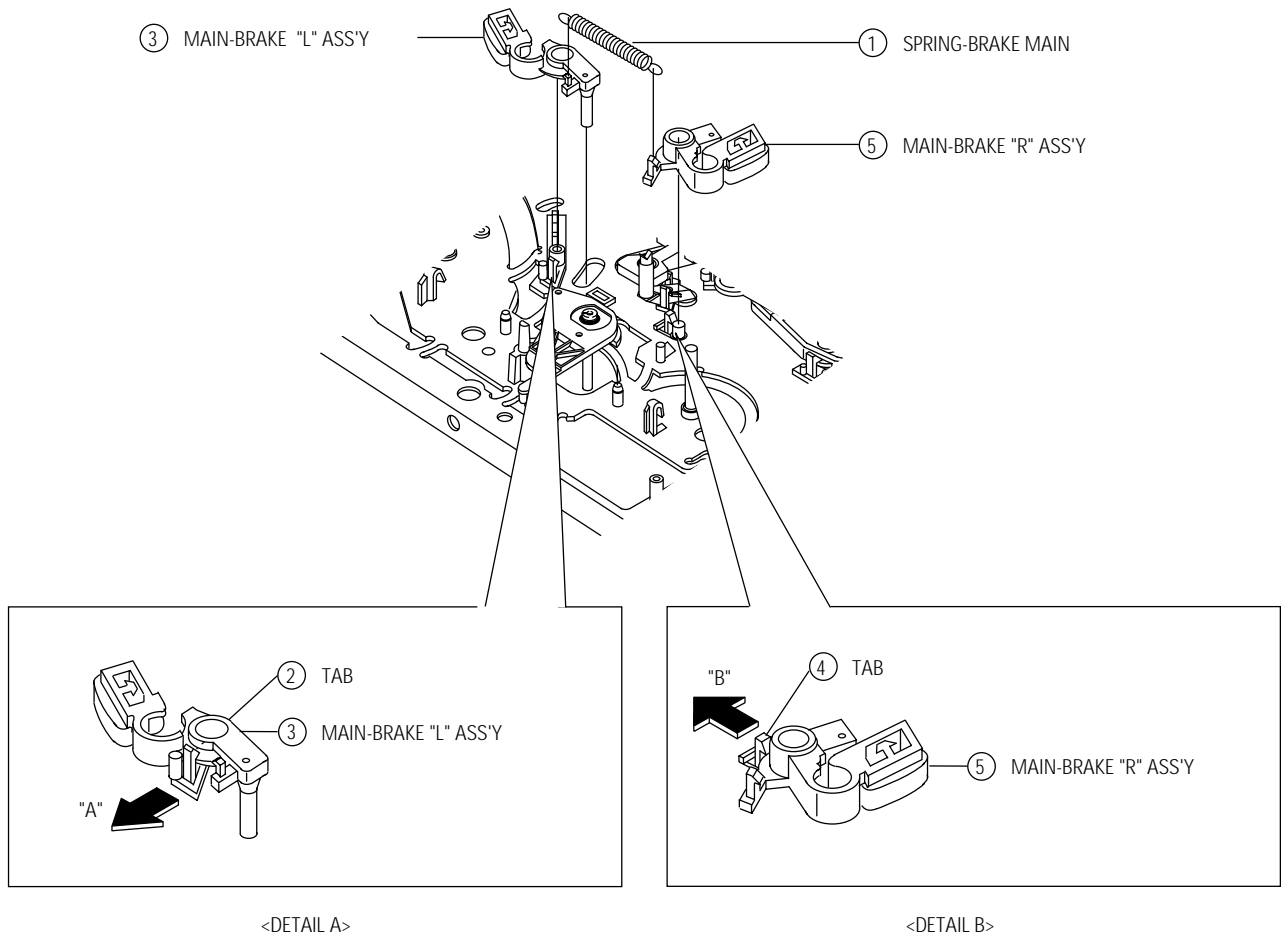

Fig. 4-28 Brake Main "L", "R" Ass'y Removal

4-4-10 Idler Ass'y Removal

1. Remove the Slit Washer ①.
2. Lift the Idler Ass'y ②.

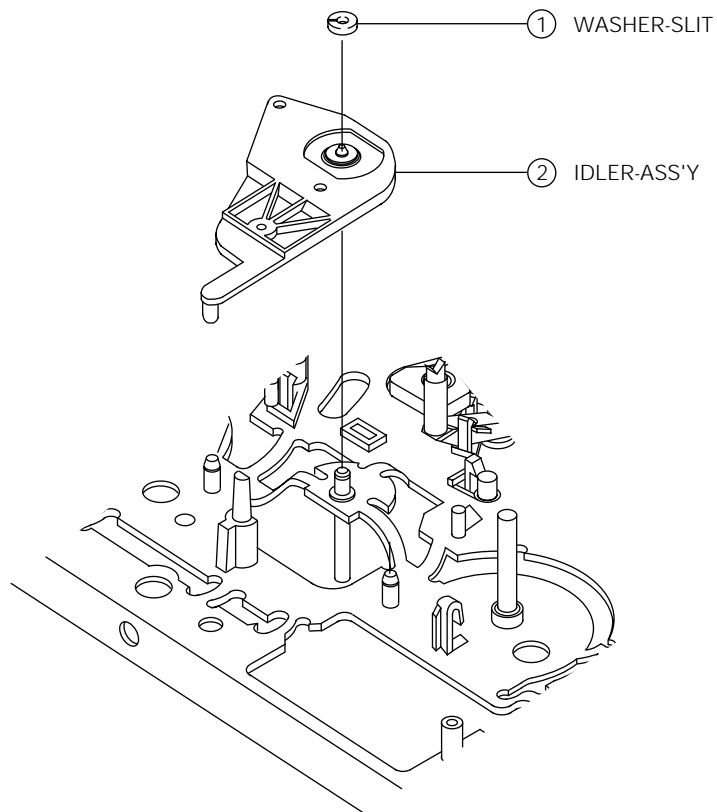

Fig. 4-29 Idler Ass'y Removal

4-4-11 Pinch Roller Unit

1. Remove the Slit Washer ①.
2. Lift the Pinch Roller Unit ②.
3. Lift the Arm Pinch Spring ③.

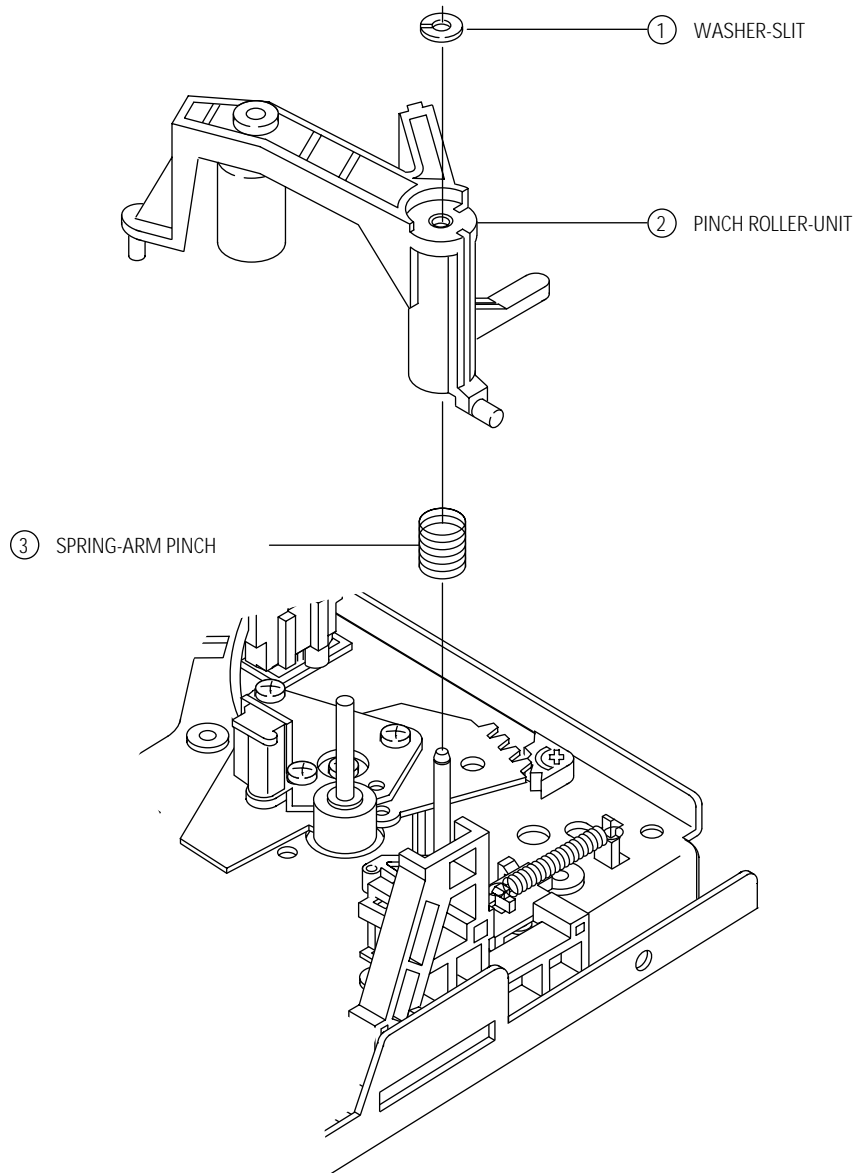

Fig. 4-30 Pinch Roller Unit Ass'y Removal

4-4-12 Assembly of Pinch Roller Unit

1. Install the Pinch Roller Unit as shown in Fig. 4-31. (Refer to A, B)

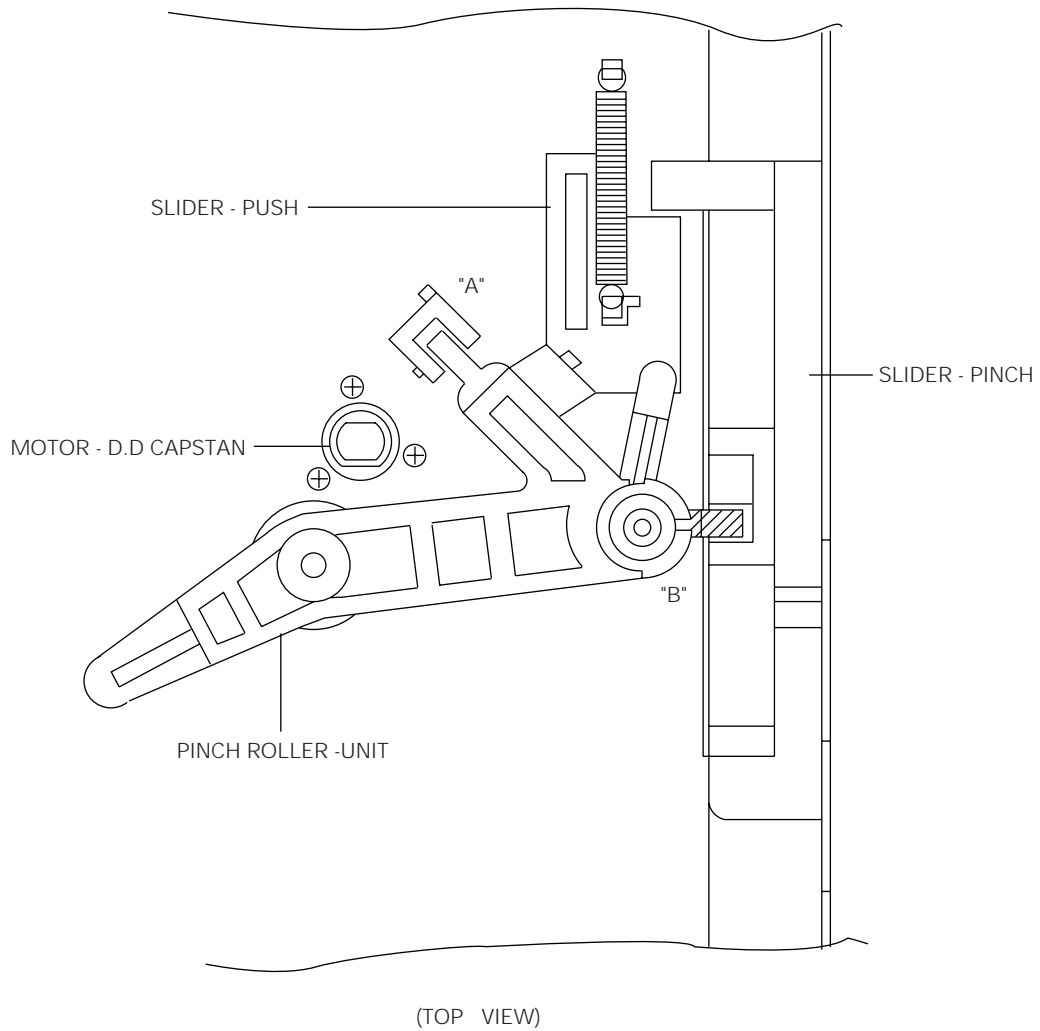

Fig. 4-31 Assembly of Unit Pinch Roller

4-4-13 Exploded View of Pinch Lever Comp Ass'y, Pinch Cam Lever, Review Arm Ass'y and Review Lever Ass'y

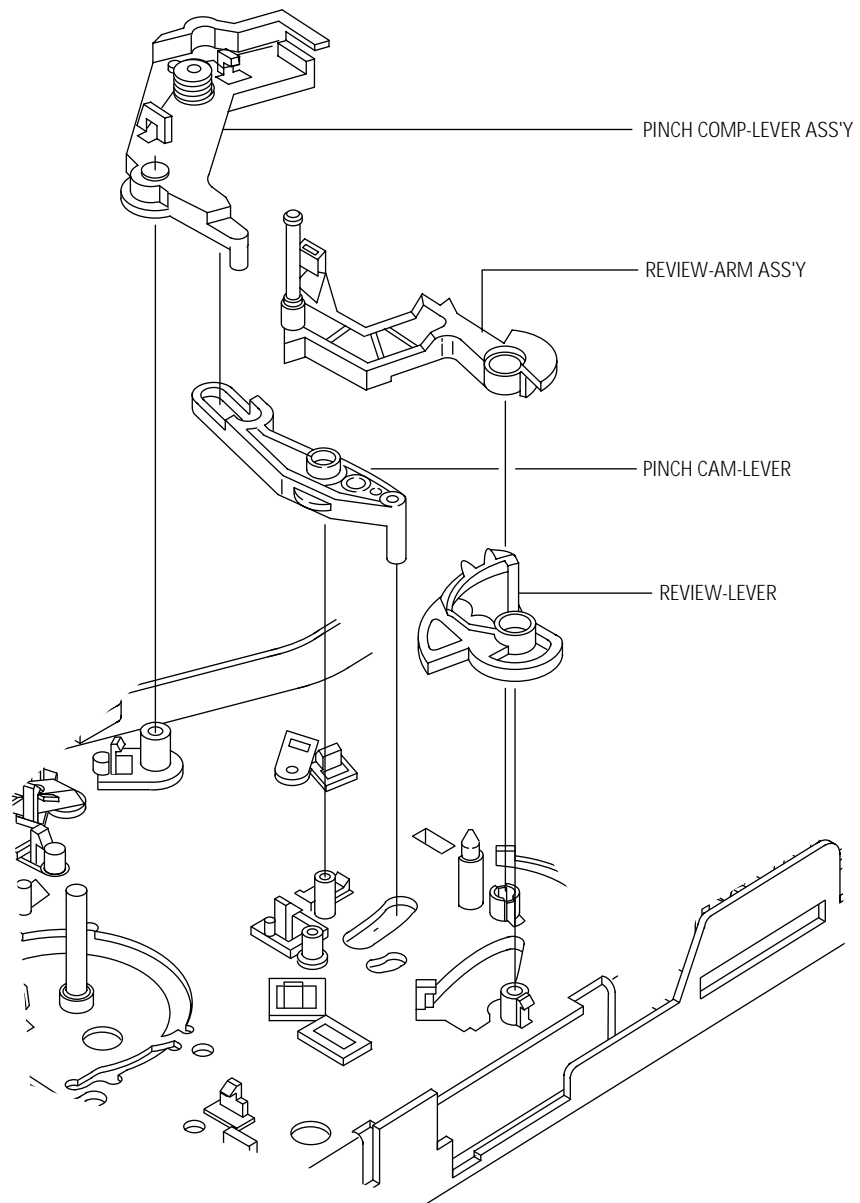

Fig. 4-32 Exploded View of Pinch Lever Comp Ass'y, Pinch Cam Lever, Arm Review Ass'y and Lever Review Ass'y

4-4-14 Pinch Lever Comp Removal

1. Release the tab ① in the direction of arrow. (Refer to detail drawing)
2. Lift the Pinch Lever Comp Ass'y ②.

Note : Don't touch the Pinch Lever Ass'y ① to Audio Head Base during removal.

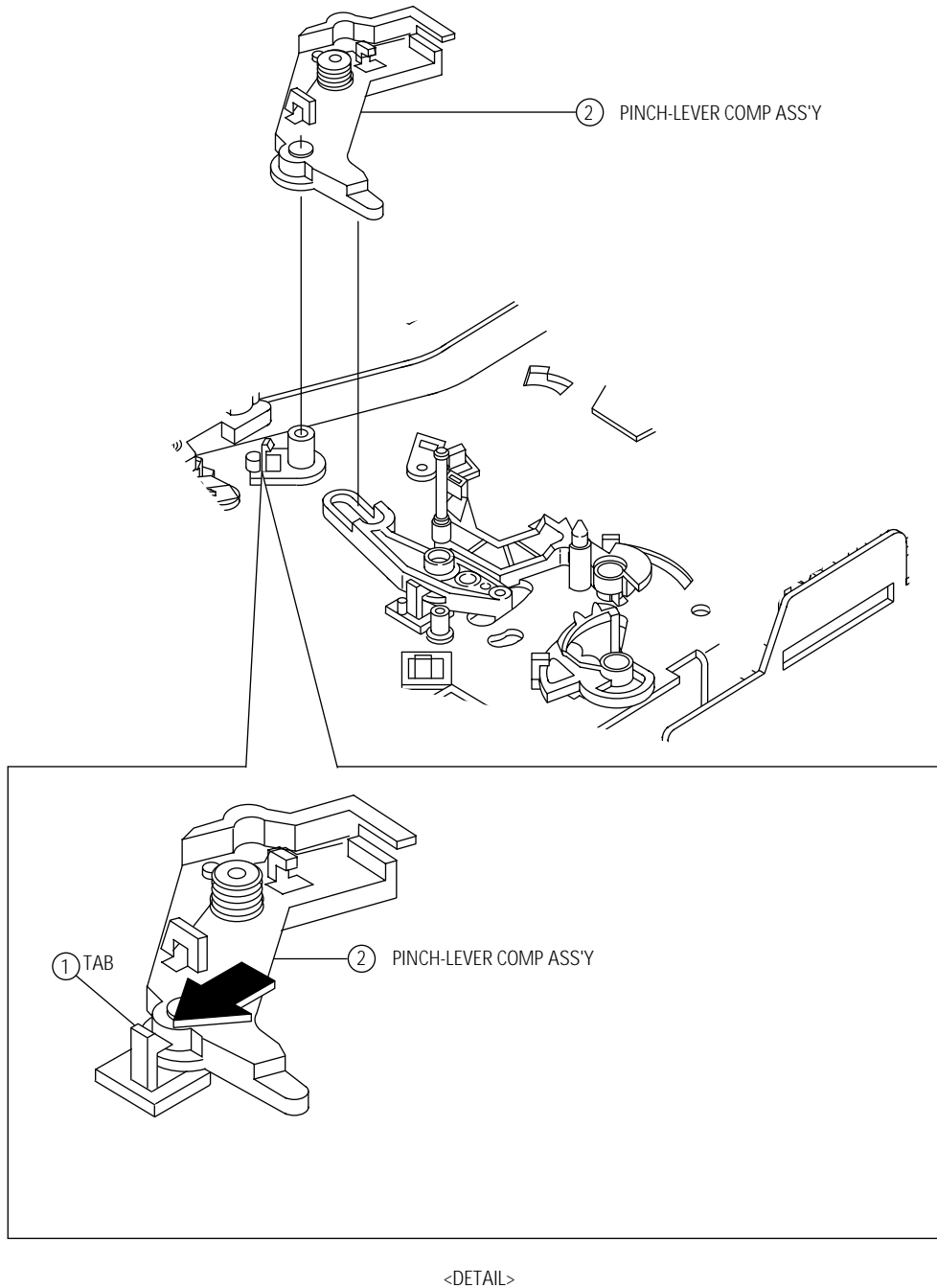

Fig. 4-33 Pinch Lever Comp Ass'y Removal

4-4-15 Pinch Cam Lever Removal

1. Release the tab ① in the direction of arrow. (Refer to detail drawing)
2. Lift the Pinch Cam Lever ②.

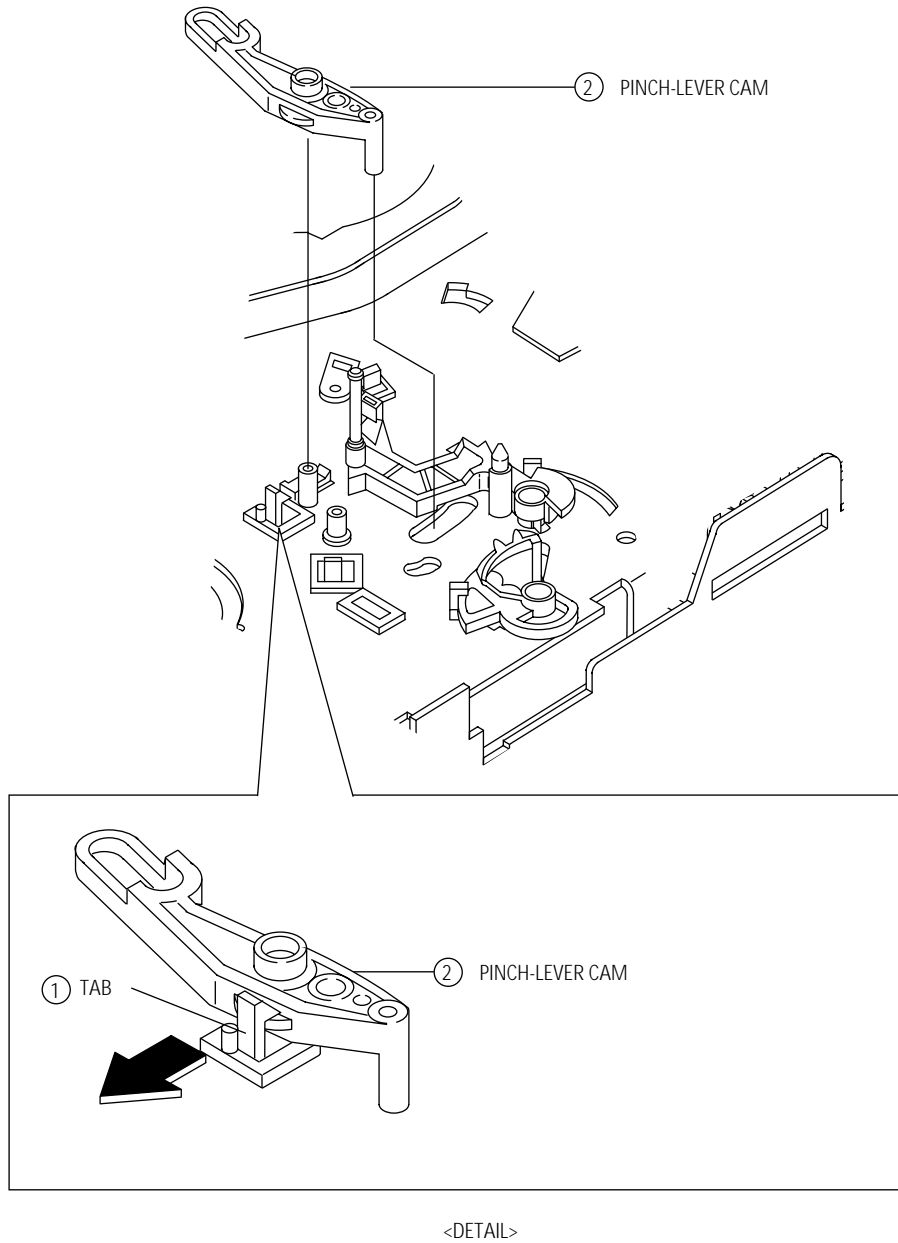

Fig. 4-34 Pinch Cam Lever Removal

4-4-16 Review Arm Ass'y Removal

1. Push the Stopper tab ① in the direction of arrow.
2. Pull the Review Arm Ass'y ② in the direction of arrow "A" and then confirm as in detail B. "B".
(Refer to detail drawing "A")
3. Release the tab ③ in the direction of arrow and then lift the Review Arm Ass'y ②.
4. Note : Be careful not to damage when removing the Review Arm Ass'y ②. (See Detail B.)

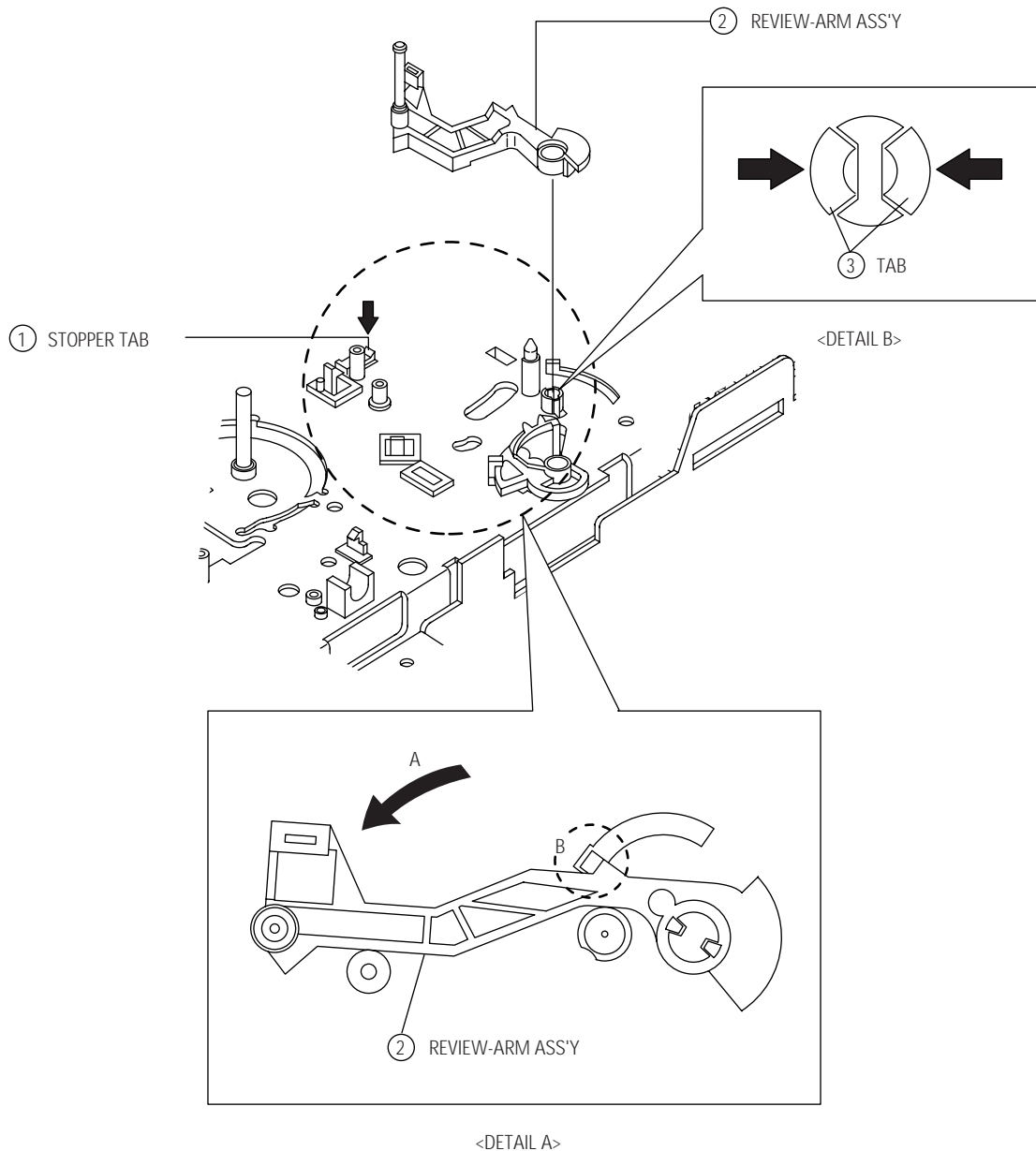

Fig. 4-35 Arm Review Ass'y Removal

4-4-17 Review Lever Removal

1. Release the tab ① in the direction of arrow. (Refer to detail drawing)
2. Lift the Review Lever ②.

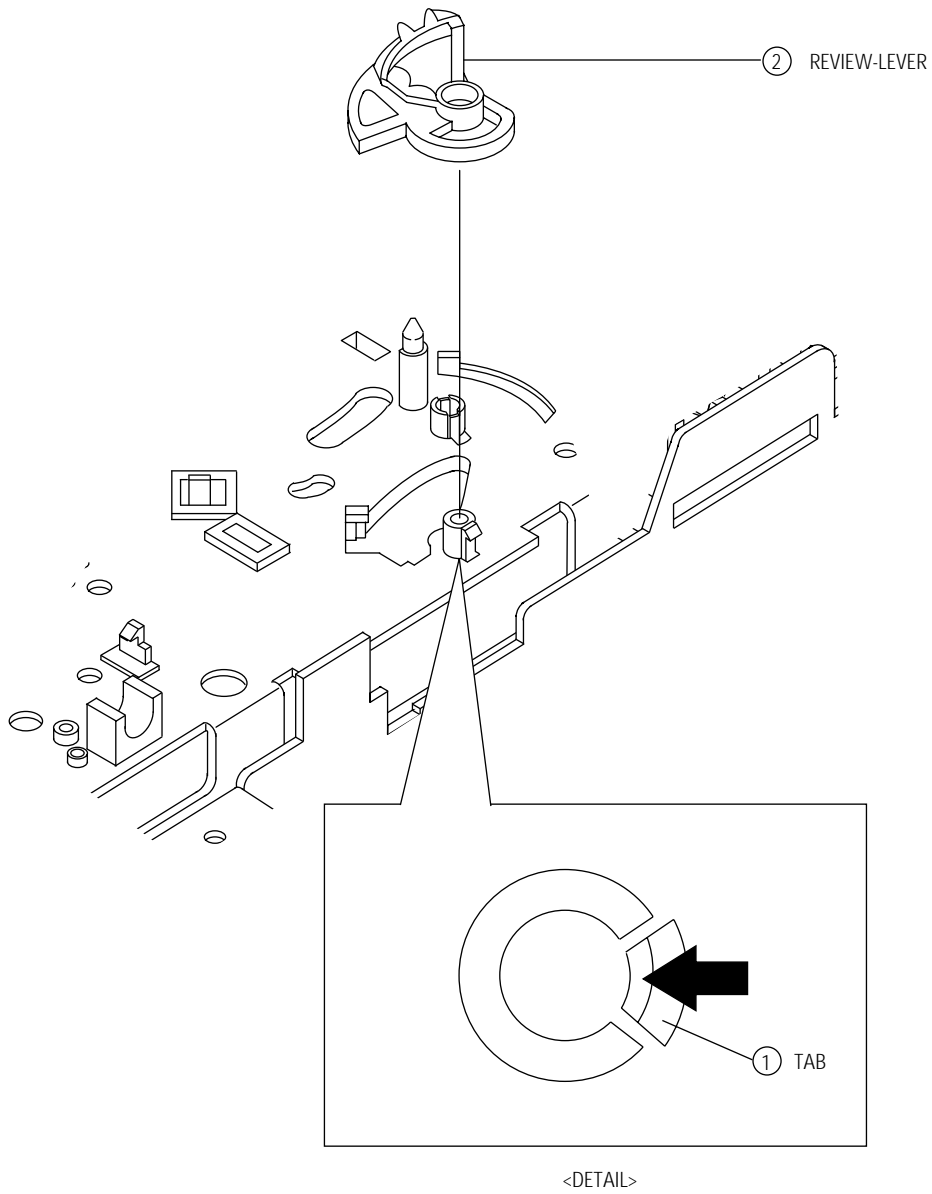

Fig. 4-36 Review Lever Removal

4-4-18 Capstan Belt Removal

1. Remove the Capstan Belt ①.
2. Note : Be careful not to touch the grease when removing or reinstalling.

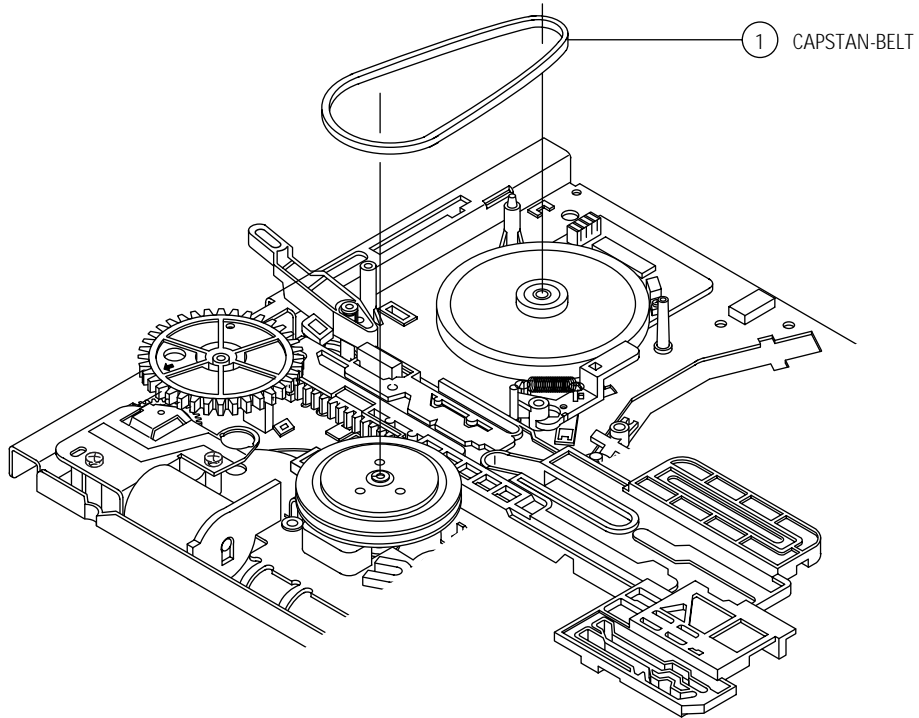

Fig. 4-37 Capstan Belt Removal

4-4-19 Capstan Brake Ass'y Removal

1. Remove the Capstan Brake Spring ①.
2. Release the tab ② in the direction of arrow. (Refer to detail drawing)
3. Lift the Capstan Brake Ass'y ③.

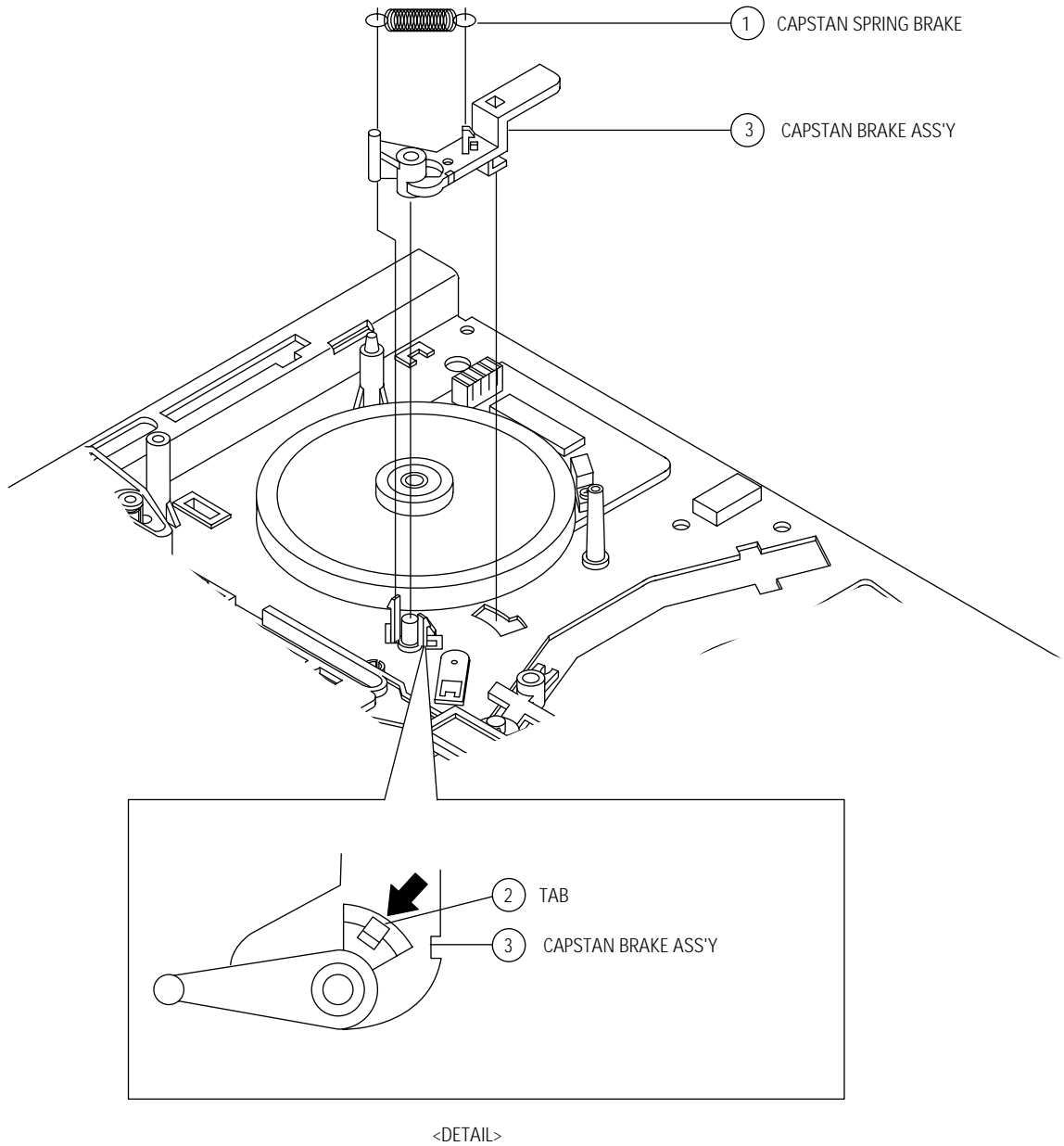

Fig. 4-38 Capstan Brake Ass'y Removal

4-4-20 Capstan Direct Drive (D.D) Motor Removal

1. Remove 3 Screws ①. (Top view)
2. Lift the Capstan D.D Motor ② in the direction of arrow. (Bottom view)

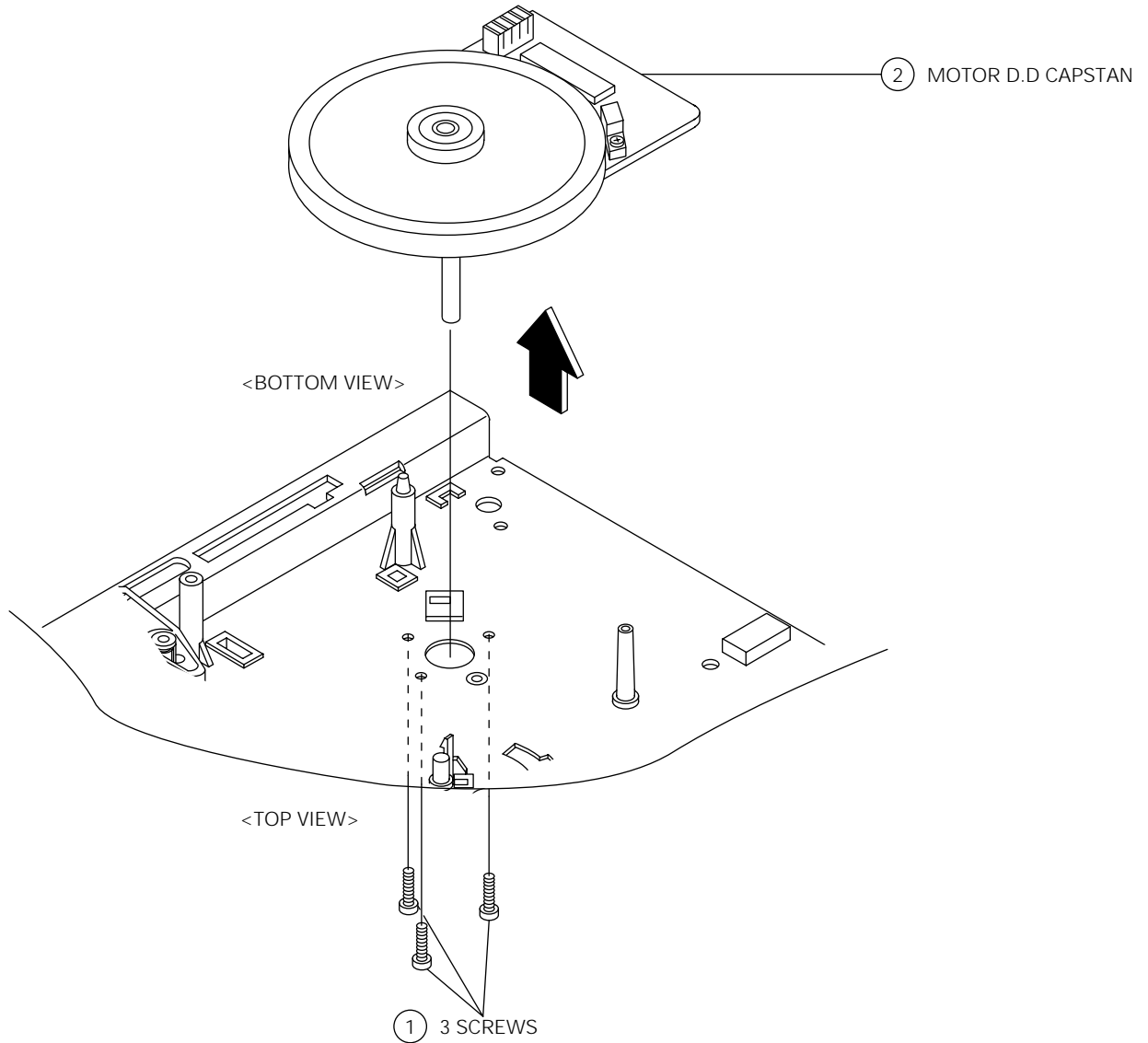

Fig. 4-39 Capstan D.D Motor Removal

4-4-21 Clutch Ass'y Removal

1. Remove the Slit Washer ①.
2. Lift the Clutch Ass'y ②.
3. Remove the Plain Washer ③.

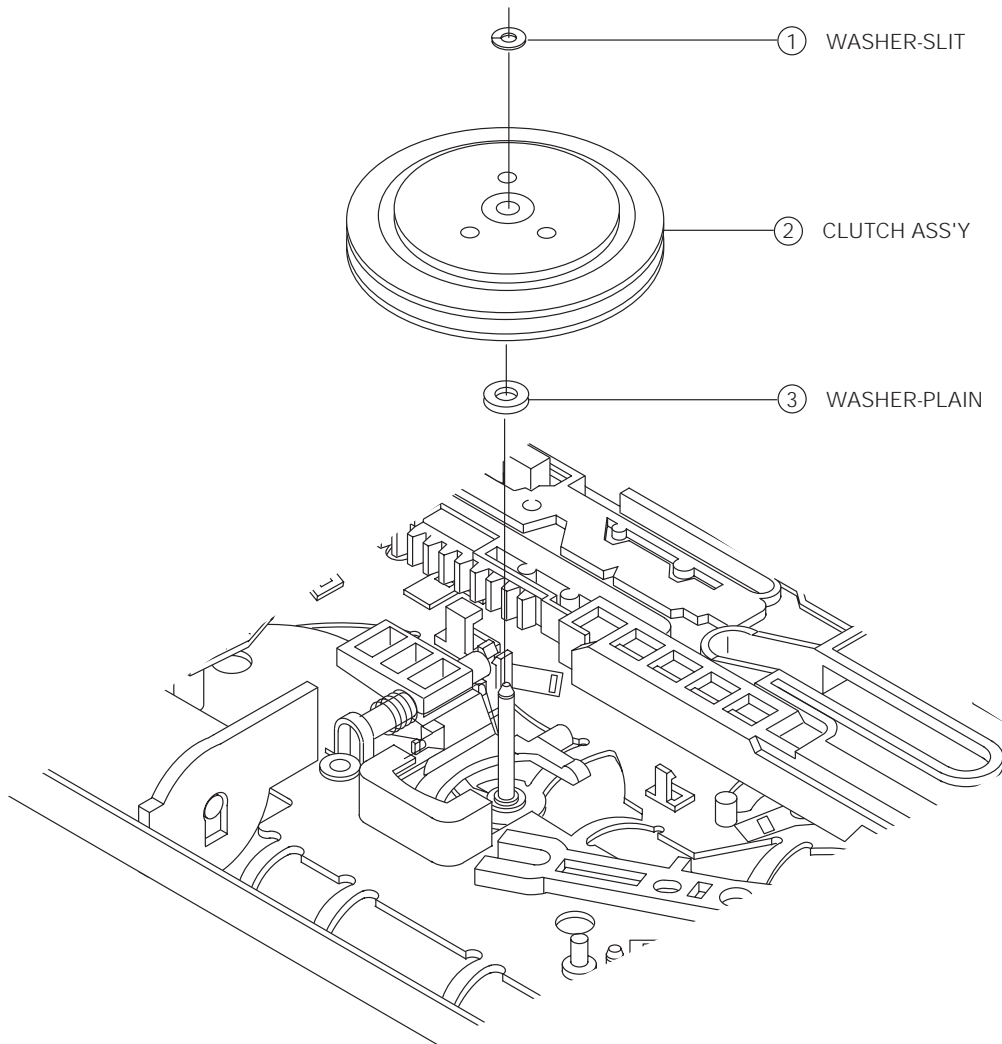

Fig. 4-40 Clutch Ass'y Removal

4-4-22 Master Gear Removal

1. Remove the Slit Washer ①.
2. Lift the Master Gear ②.

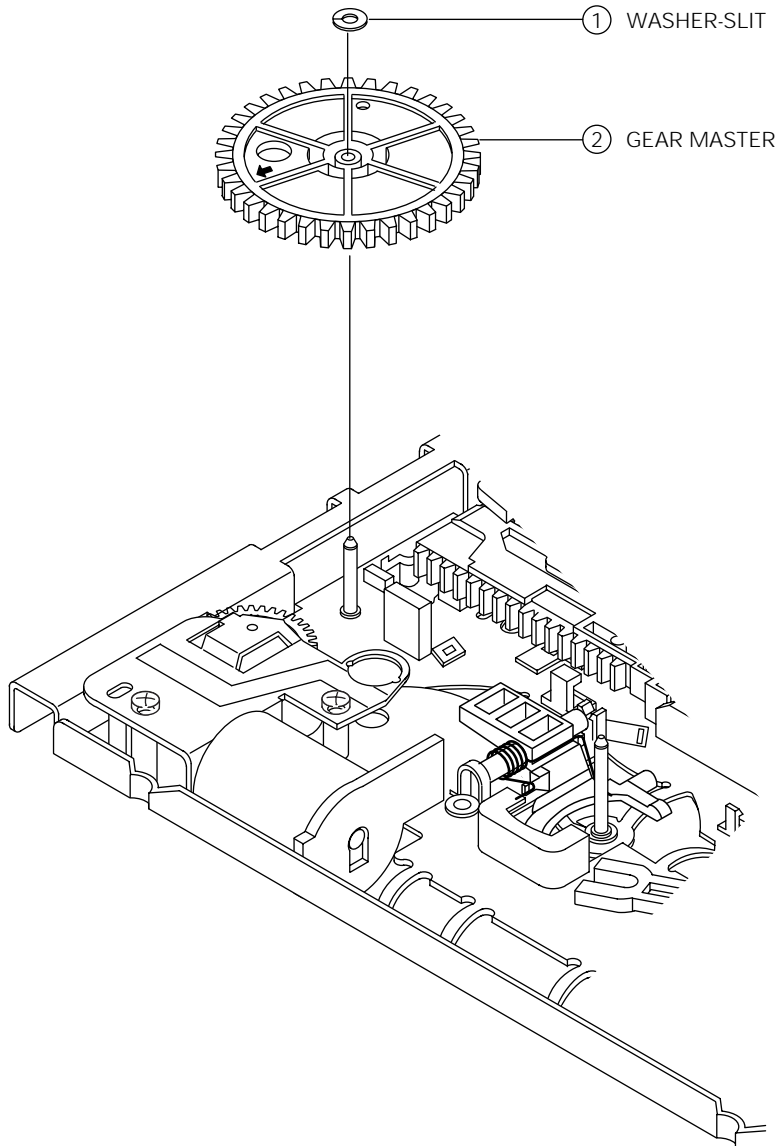

Fig. 4-41 Master Gear Removal

4-4-23 Assembly of Master Gear

1. When reinstalling, be sure to align the arrow of the Master Gear ① with home Gear of the Worm-Wheel Gear ②. (Refer to timing point)

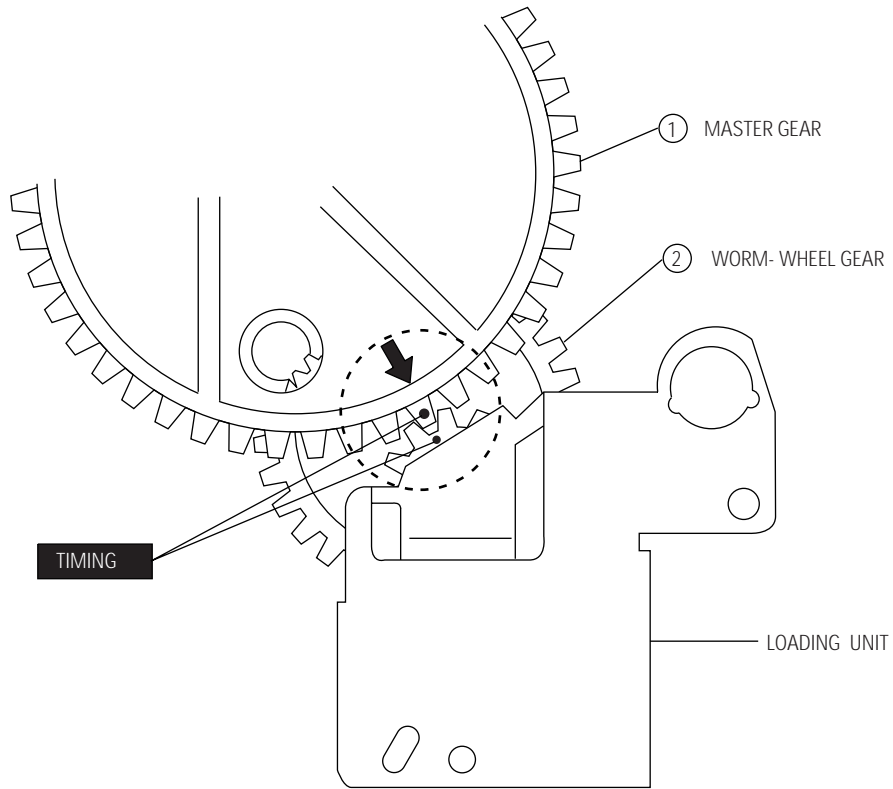

Fig. 4-42 Master Assembly of Gear

4-4-24 Loading Unit Removal

1. Remove 2 Screws ①.
2. Lift the Loading Unit ② in the direction of the arrow.

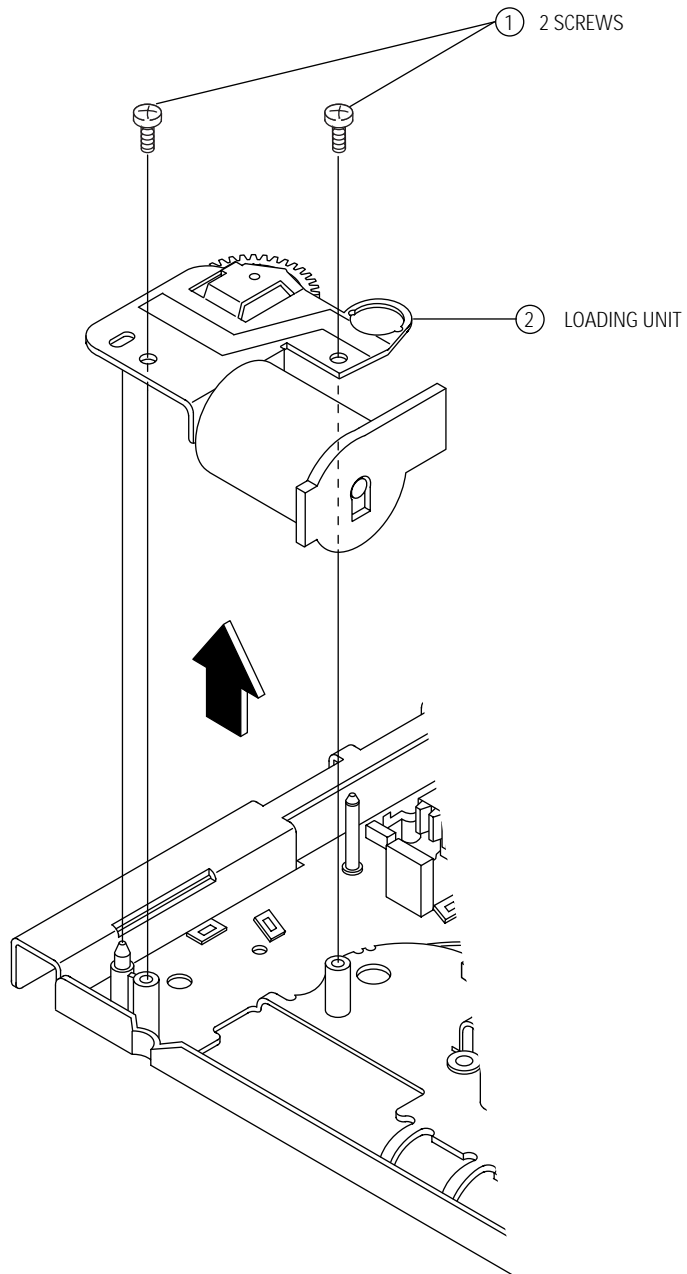

Fig. 4-43 Loading Unit Removal

4-4-25 Slide Pinch Lever Removal

1. Remove the Slit Washer ①.
2. Lift the Slide Pinch Lever ②.

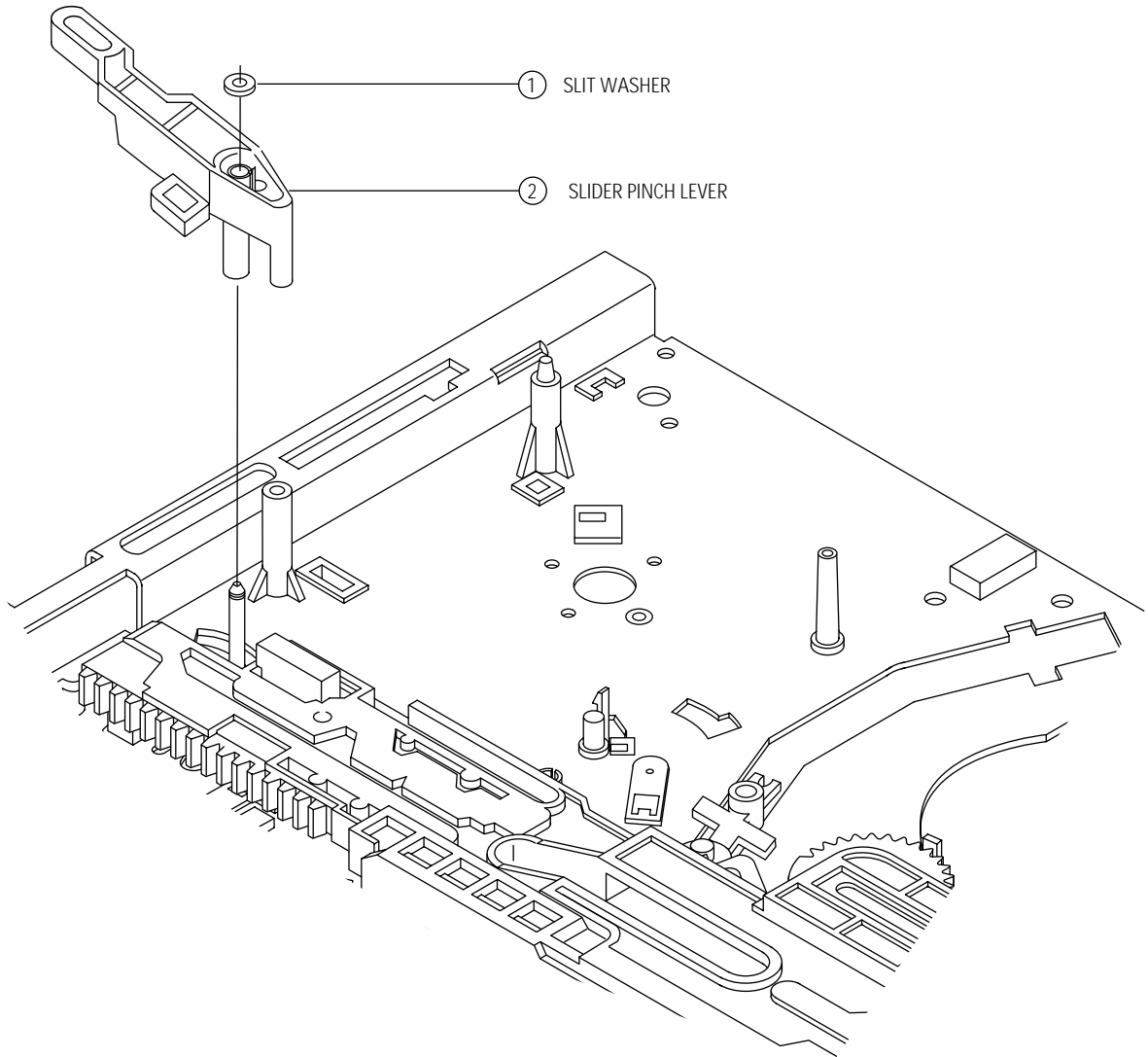

Fig. 4-44 Slide Pinch Lever Removal

4-4-26 Assembly of Slide Pinch Lever

1. Pull the Slide Lever ① to the end in the direction of arrow.
2. Insert the Slide Lever ① into the hole of Slide Pinch Lever ②. (Refer to detail "A")

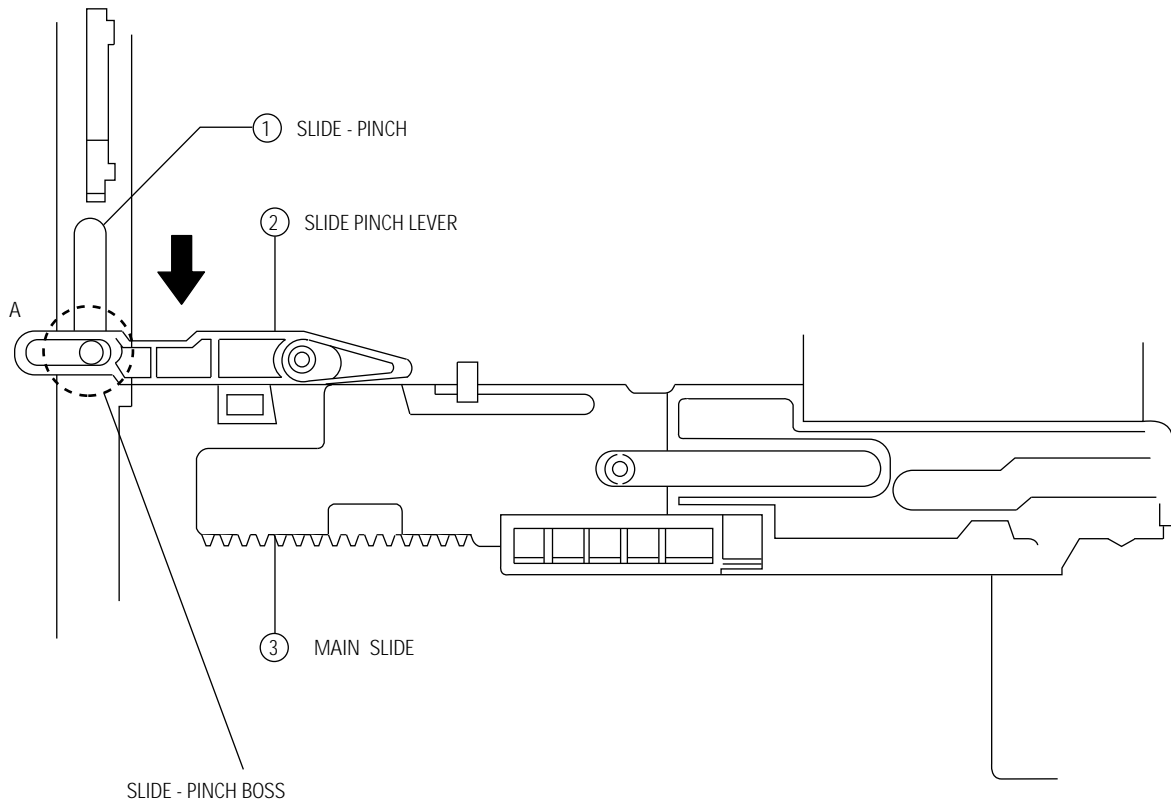

Fig. 4-45 Assembly of Slide Pinch Lever

4-4-27 Main Slide Removal

1. Remove the Slit Washer ①.
2. Release 3 tabs ②, ③, ④ in the direction of arrow.
3. Lift the Main Slide ⑤.

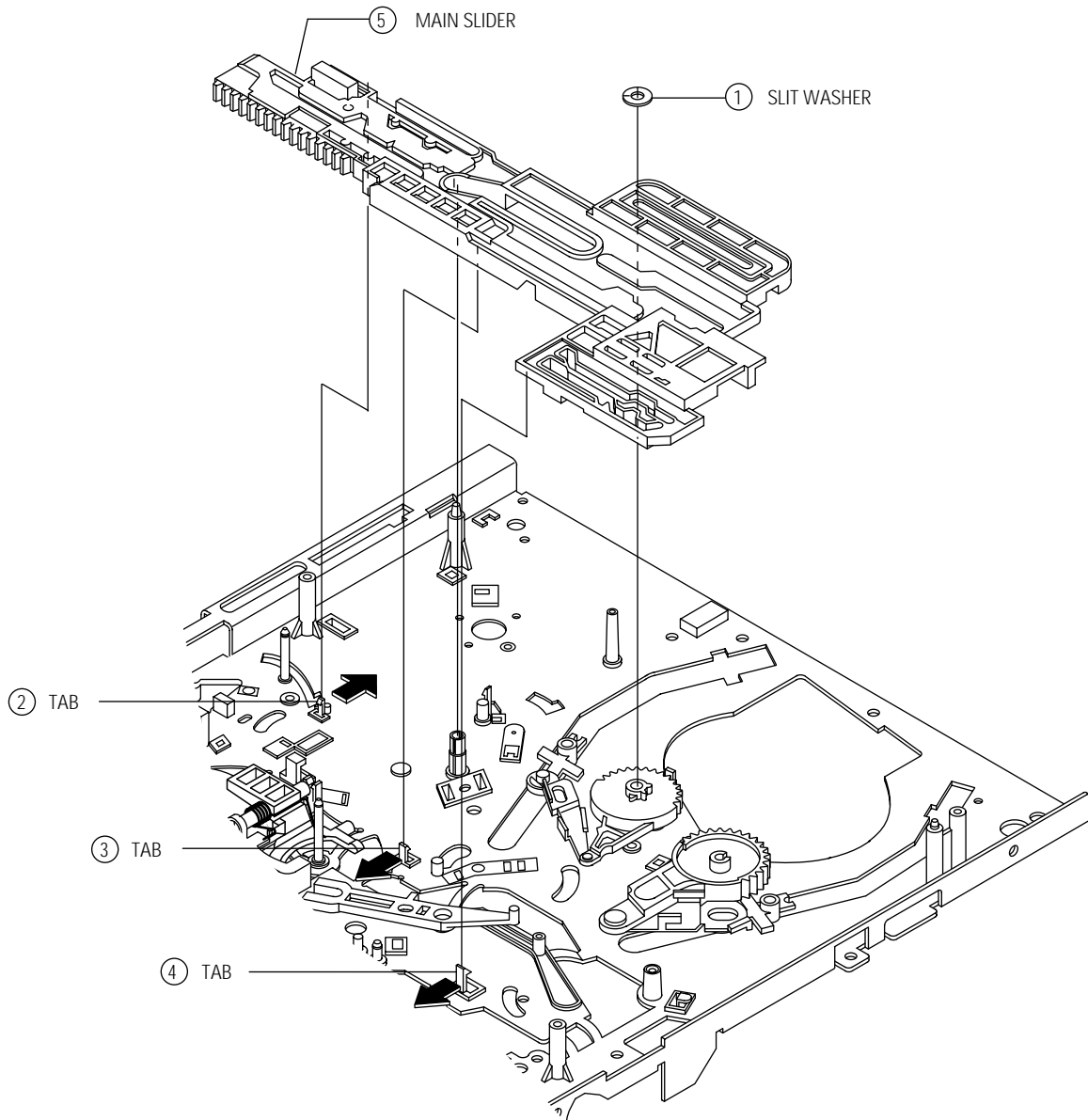

Fig. 4-46 Slide Main Removal

4-4-28 Assembly of Main Slide

1. Install the shaft of Loading "R" Gear Ass'y into the left of the Main Slide Hole and secure with the Slit Washer ②. (Refer to detail "A")
2. Insert the Tension Control Lever ③ and the Idler Change Lever ④ into the Main Slide Hole. (Refer to detail "B")
3. After confirming the above items 1, 2 install the Main Slide and secure with tabs (a, b, c).
4. Note : Be sure to assemble the Main Slide while the Loading L/R Gear Ass'y is in unloading position.

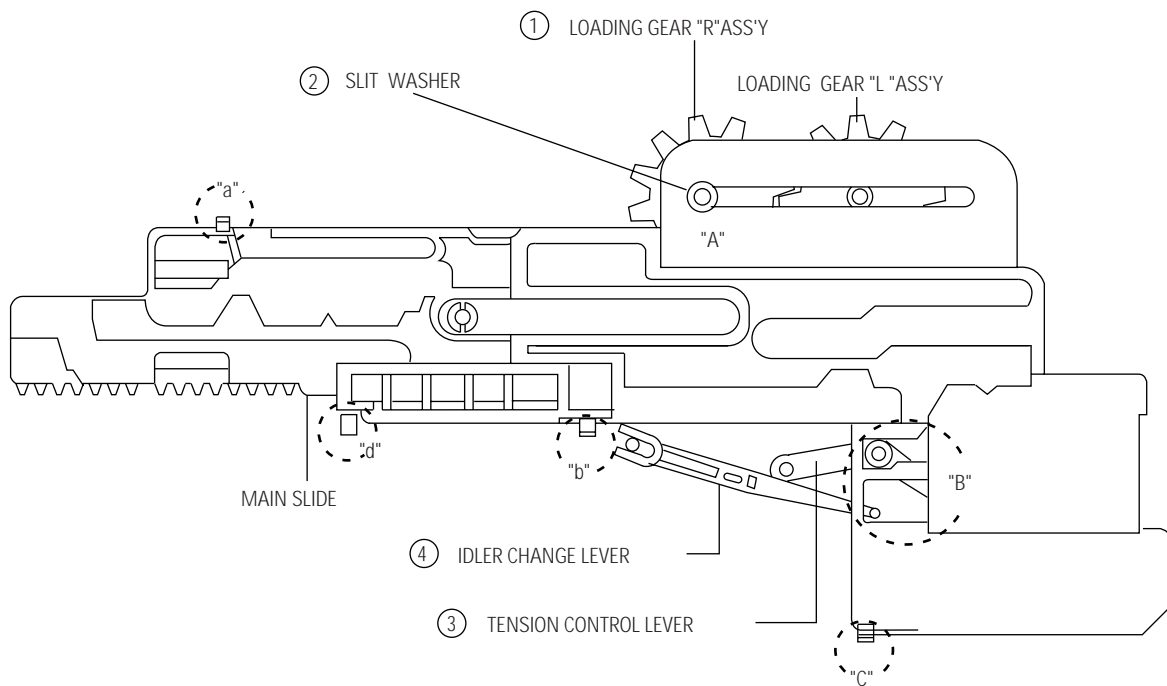

Fig. 4-47 Assembly of Slide Main

4-4-29 Shift Lever Ass'y Removal

1. Hang the Lever Shift Spring ① to the claw of the Shift Lever ③. (Refer to detail drawings A, B)
2. Release the tab ② in the direction of arrow.
3. Lift the Shift Lever ③.

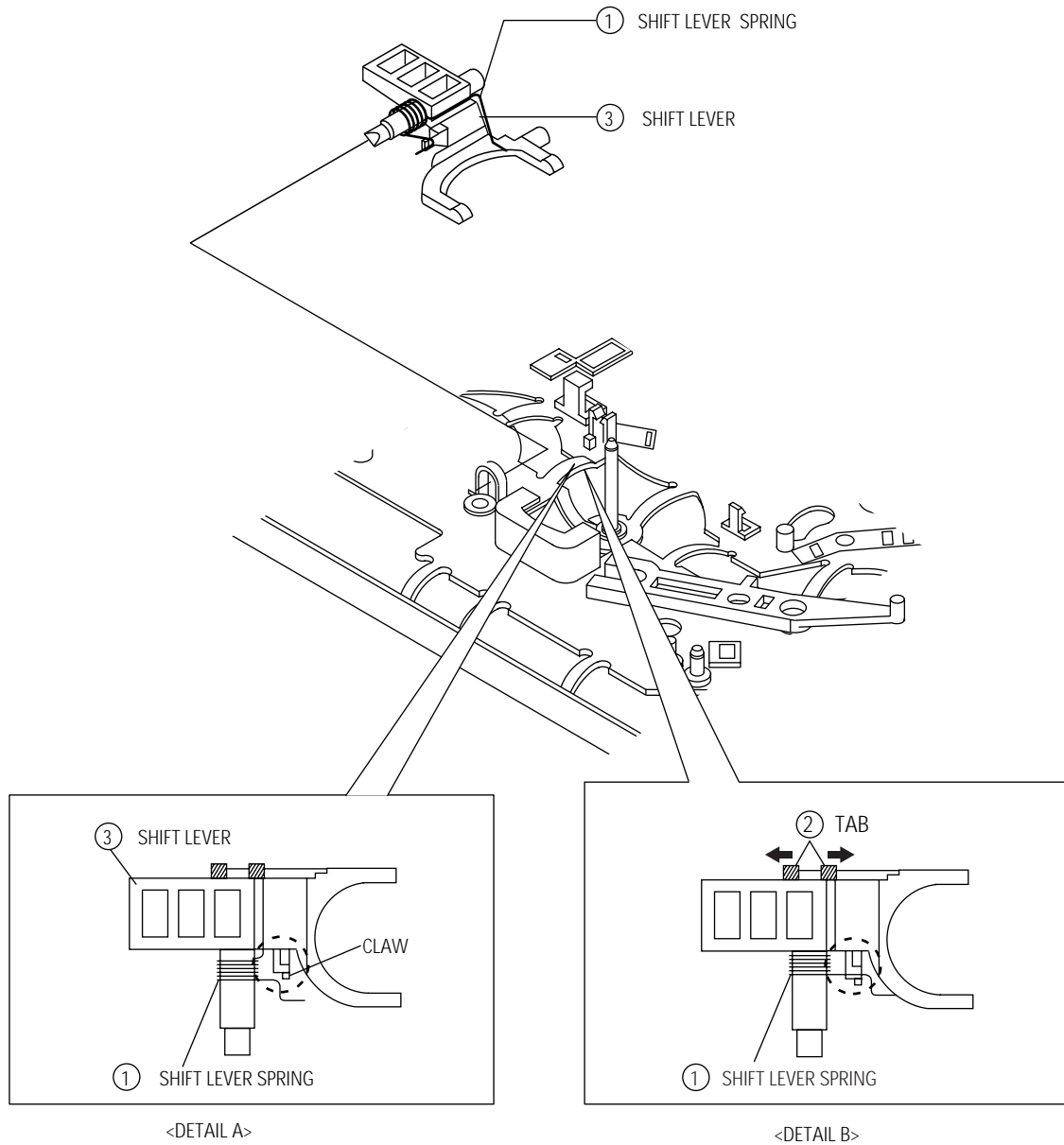

Fig. 4-48 Shift Lever Ass'y Removal

4-4-30 Lever Changes Idler Removal

1. Release the tab ① in the direction of arrow. (Refer to detail drawing)
2. Lift the Lever Change Idler ②.

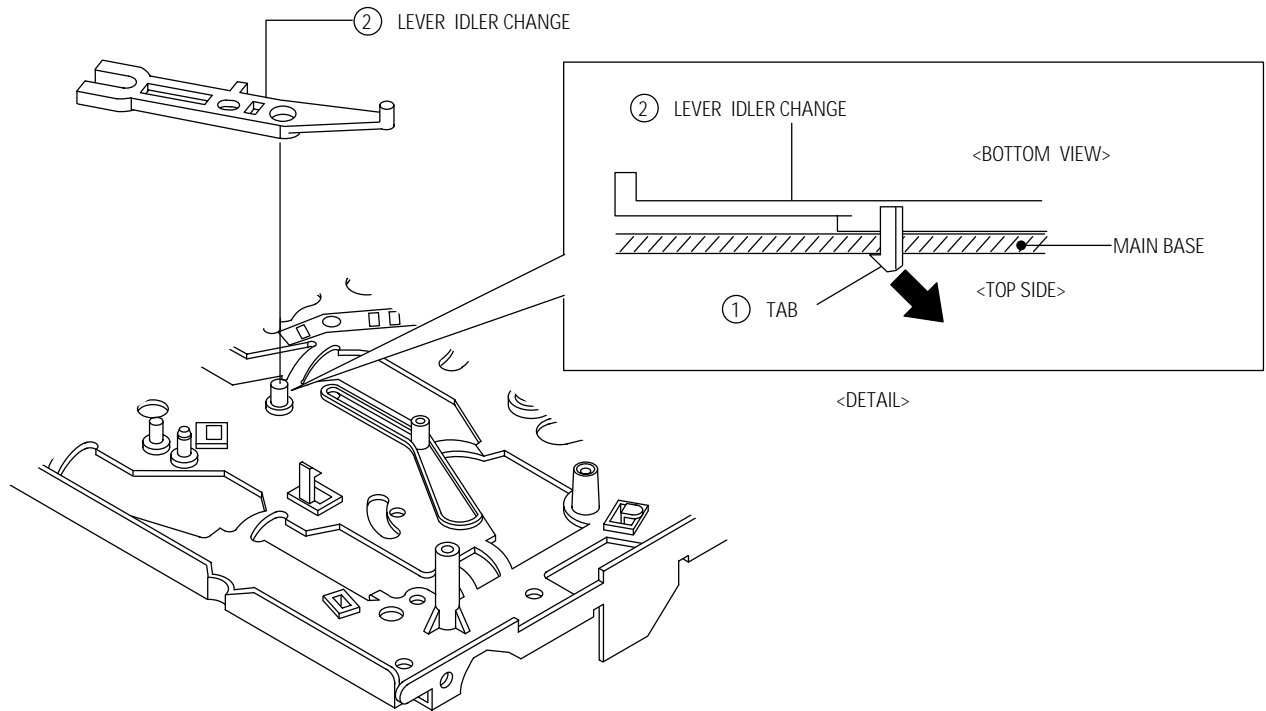

Fig. 4-49 Idler Change Lever Removal

4-4-31 Loading "L" Gear , "R" Gear Ass'y Removal

1. Remove the Loading "R" Gear Ass'y ② from the Roller "T" Guide ③ by pushing the Loading "R" Spring ① in the direction of arrow. (Refer to detail drawing A)
2. Remove the Loading "L" Gear Ass'y ⑤ from the Roller "S" Guide ⑥ by pushing the Loading "L" Spring ④ in the direction of arrow. (Refer to detail drawing B)
3. Lift the Loading "R" Gear Ass'y ②.
4. Lift the Loading "L" Gear Ass'y ⑤ by pushing the tab ⑦ of the Loading "L" Gear Ass'y ⑤. (Refer to detail drawing C)

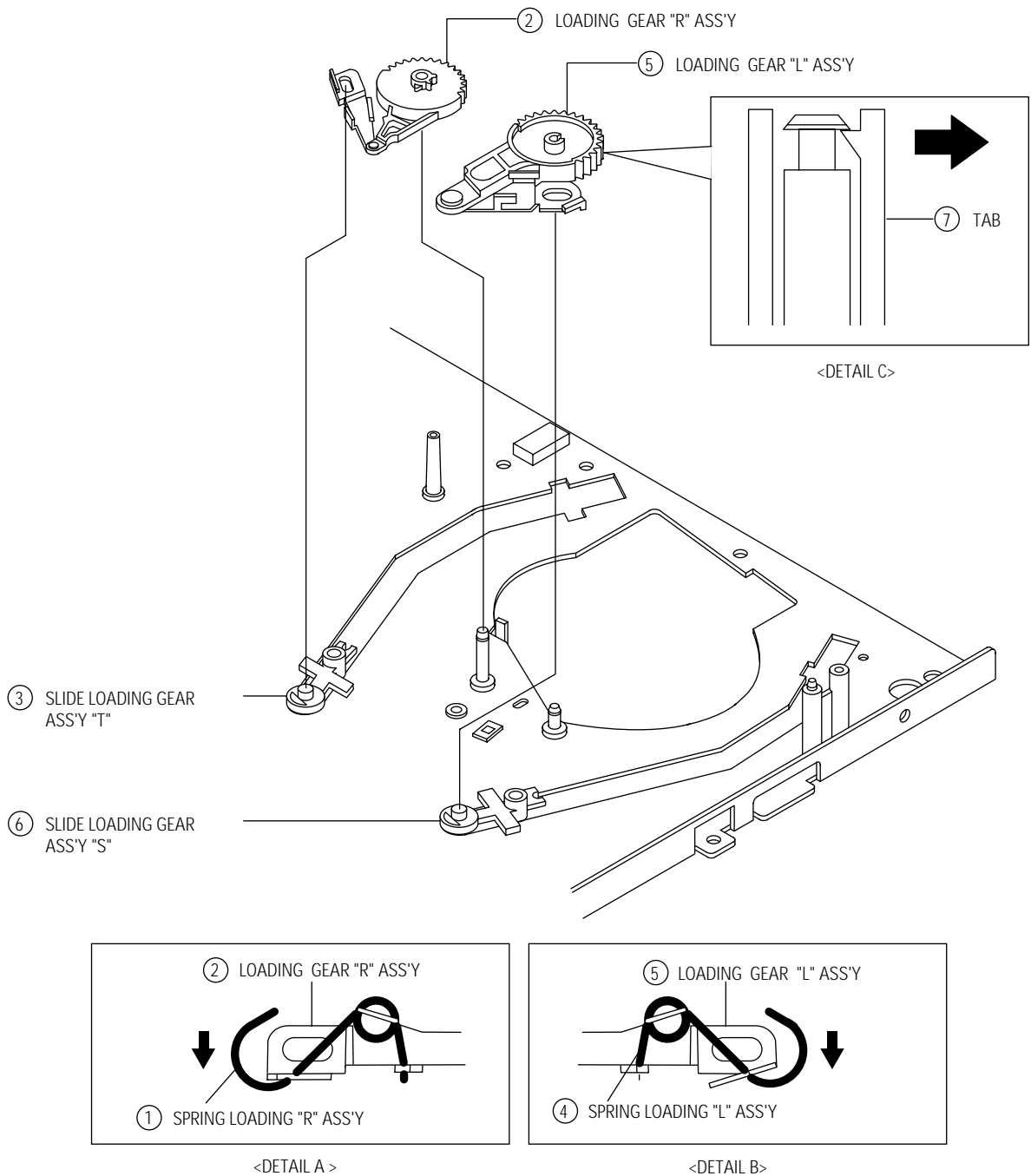

Fig. 4-50 Loading Gear "L" , "R" Ass'y Removal

4-4-32 Assembly Loading Gear "L", "R"

1. When reinstalling, be sure to align 2 arrow as shown in Fig. 4-51. (Refer to timing point)

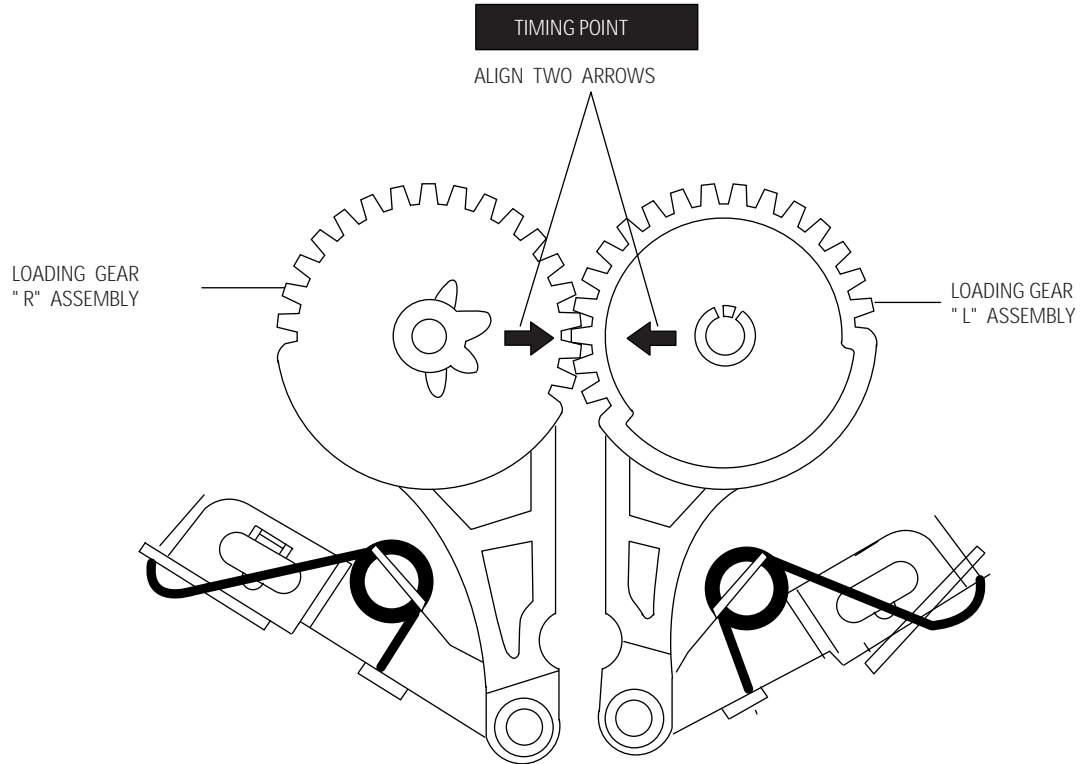

Fig. 4-51 Assembly Loading Gear "L", "R"

4-4-33 Pinch Slide Removal

1. Push the tab ① in the direction of arrow "A". (Refer to detail drawing)
2. Lift the Pinch Slider ② in the direction of arrow "B".

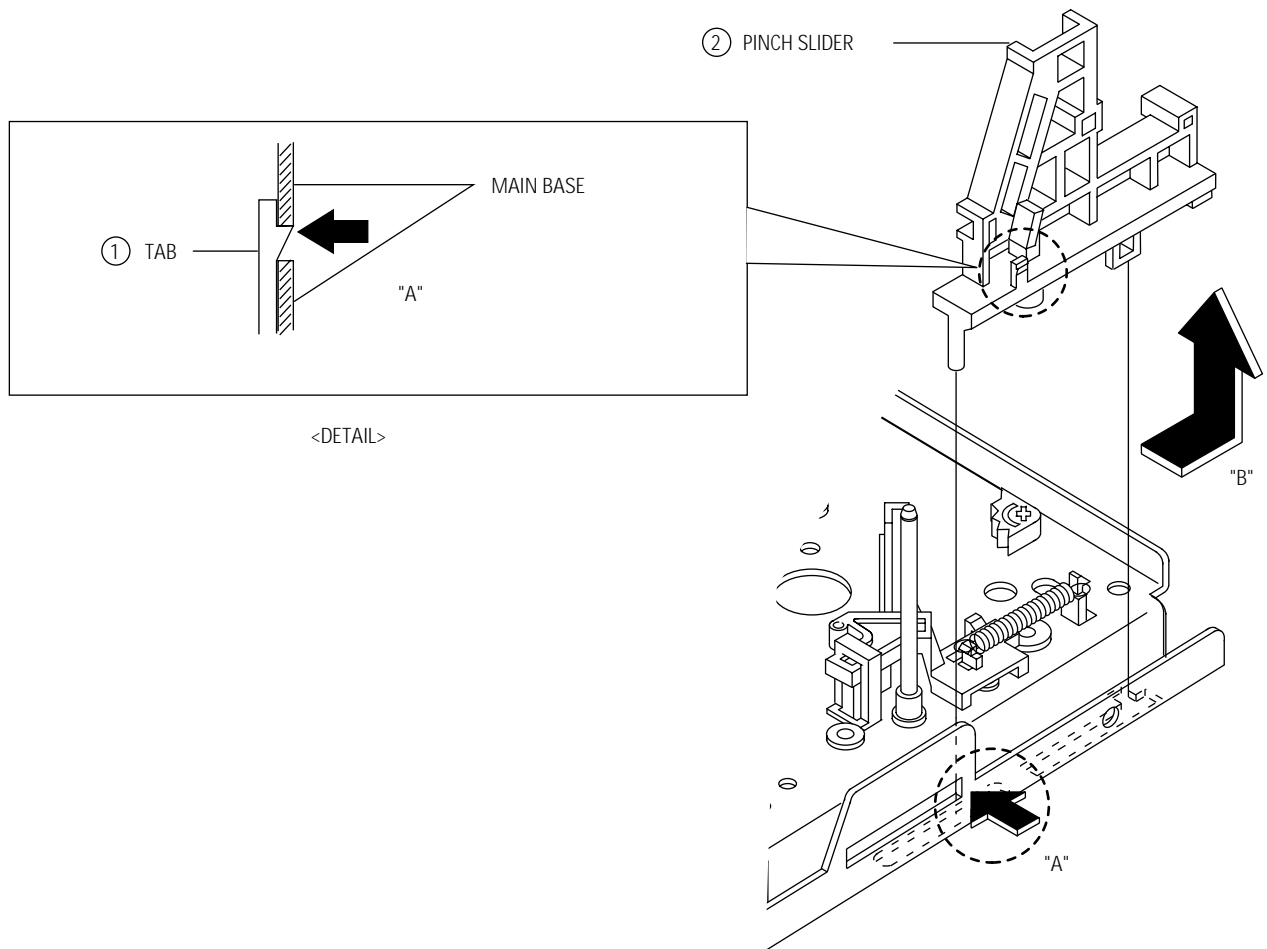

Fig. 4-52 Pinch Slide Removal

4-4-34 Push Slide Removal

1. Remove the Slide Push Spring ①.
2. Push the Slide ② in the direction of arrow "A".
3. Lift the Push Slide ② by pushing the tab ③ in the direction of arrow "B". (Refer to detail drawing)

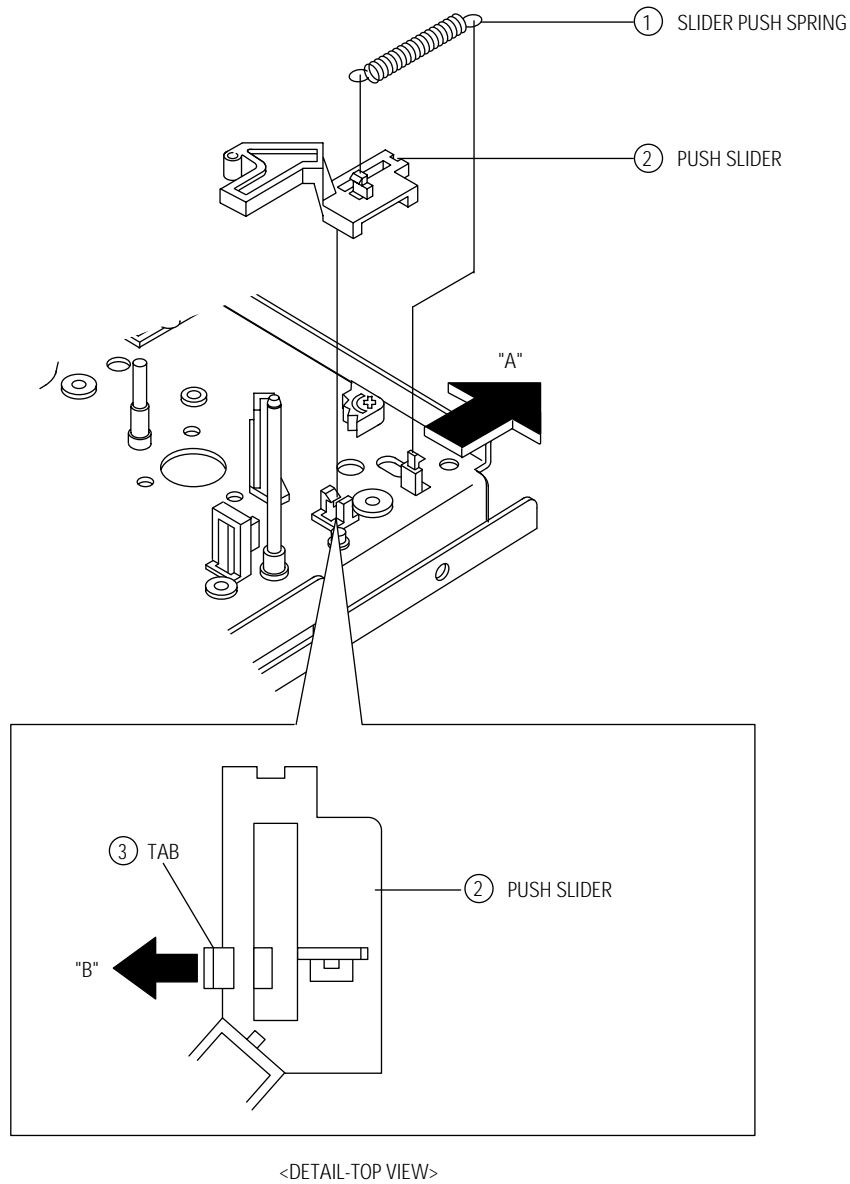

Fig. 4-53 Push Slide Removal

4-4-35 LED Prism Removal

1. Release the tab ① in the direction of arrow. (Refer to detail drawing)
2. Lift the LED Prism ②.

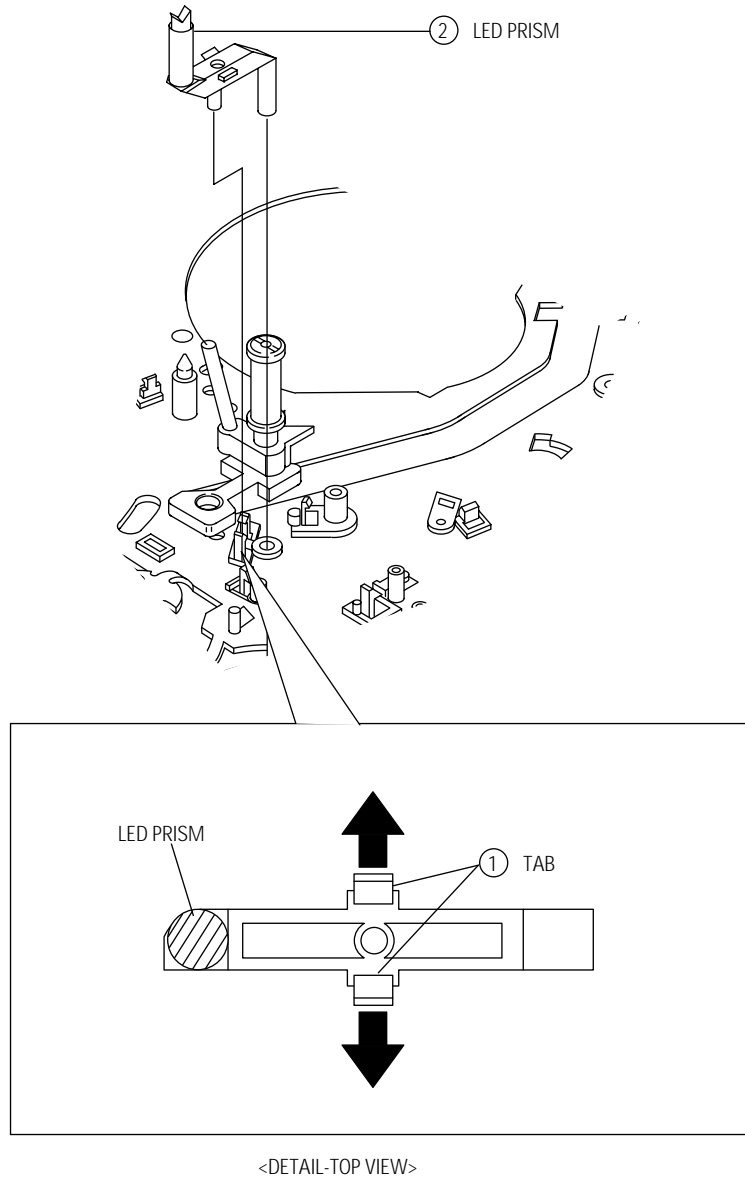

Fig. 4-54 LED Prism Removal

4-4-36 Record Switch Lever Removal

1. Remove the Record Switch Spring ①.
2. Release the tab ② in the direction of arrow. (Refer to detail drawing)
3. Lift the Record Switch Lever ③.

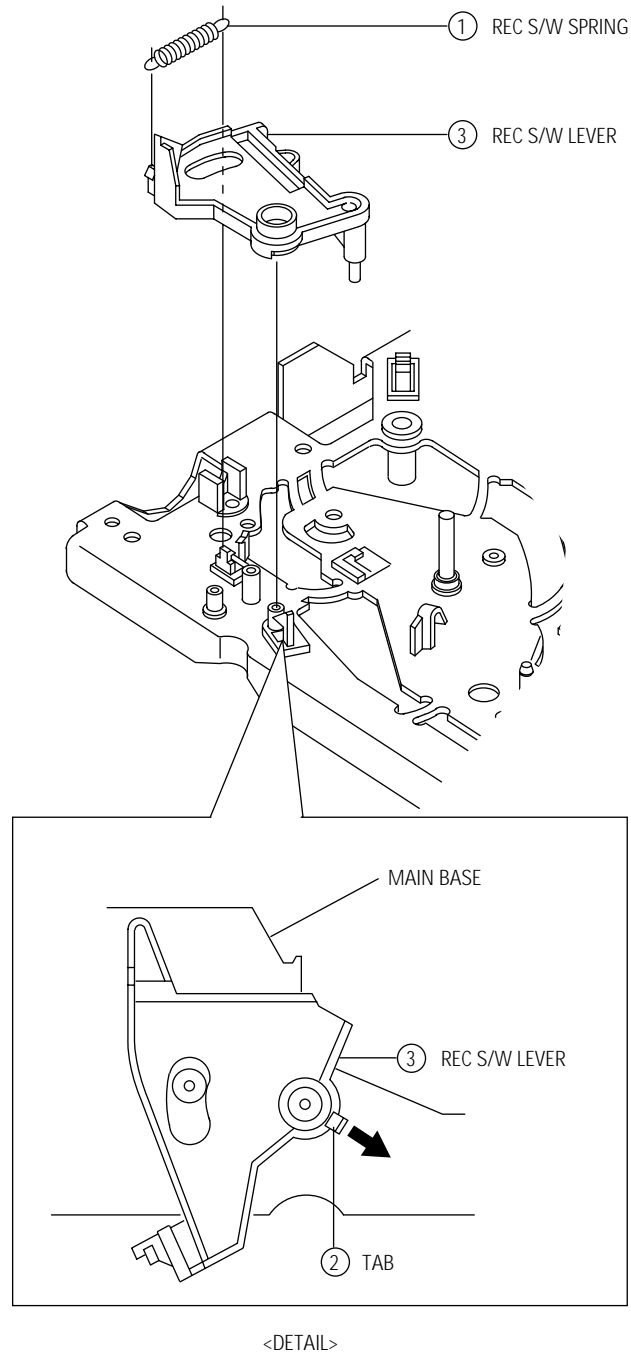

Fig. 4-55 Record Switch Lever Removal

4-4-37 Full Erase Head Removal

1. Remove 1 Screw①.
2. Lift the F/E Magnet Head ②.

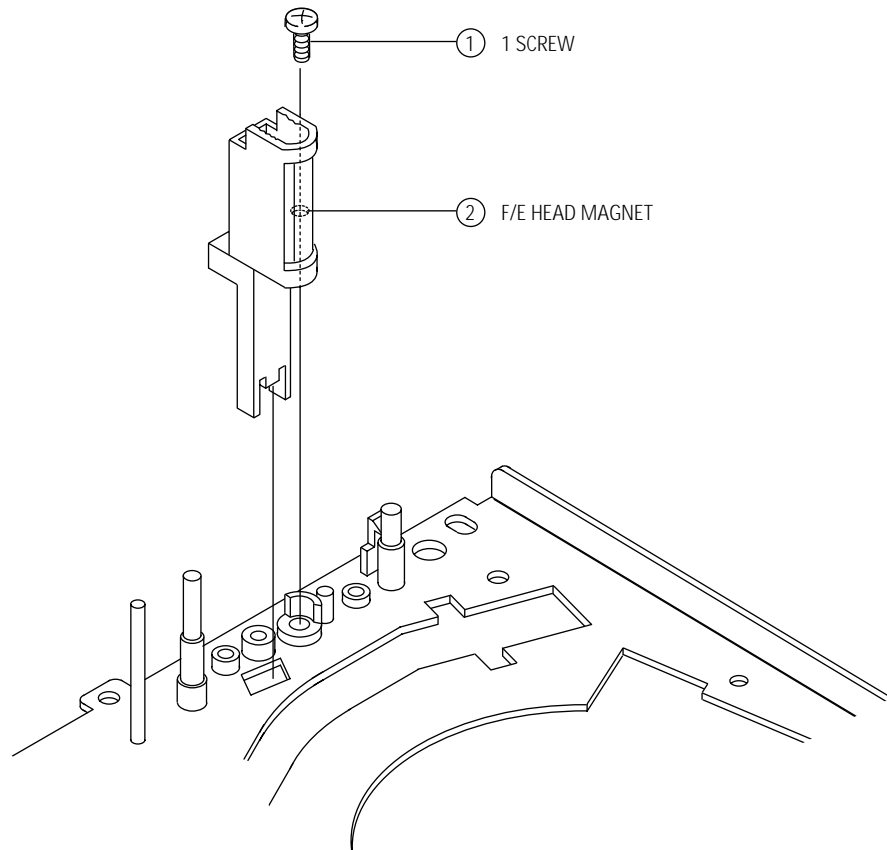

Fig. 4-56 Full Erase Head Removal

4-4-38 ACE Head Removal and Reassembly

1. Release the tab ① holding ACE Holder toward arrow. (Refer to detail drawing A)
2. Remove 1 Screw ②.
3. Lift the Magnet ACE Head Ass'y ③.
4. Assembly : When reinstalling, be sure to align the 3 teeth of X-Position adjustment gear with the 2 slots of the ACE Head Base.
5. Note : When adjusting the X-Position adjustment gear using (+) driver, do not apply too much force.

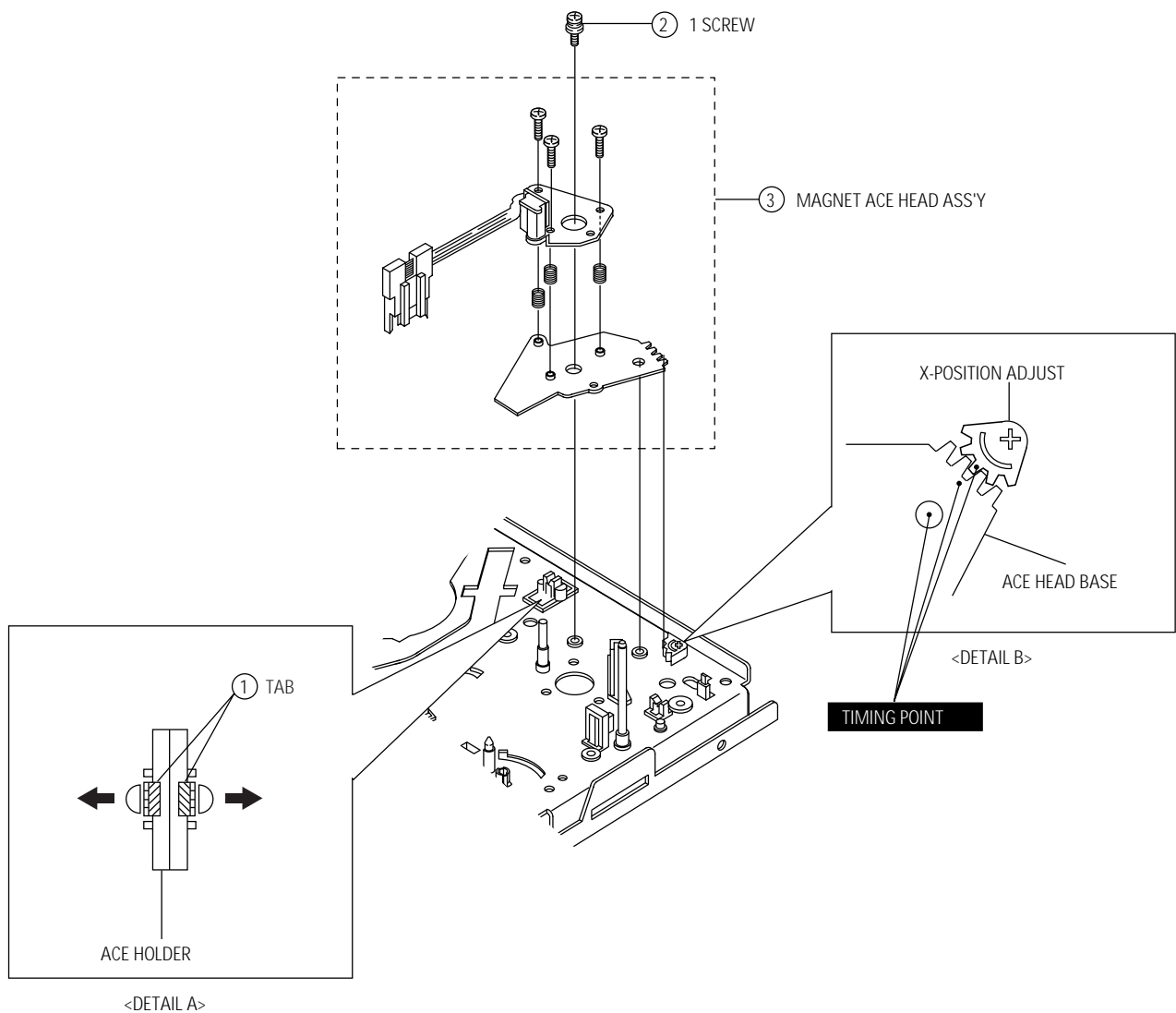

Fig. 4-57 ACE Head Ass'y Removal and Reassembly

4-4-39 Removal of Gear Loading Sildes "S" and "T"

1. Remove the Cylinder Ass'y from the Main Base. (Refer to Fig. 4-12, 4-13)
2. Remove the Slide "S", "T" from the Loading "L", "R" Gear Ass'y. (Refer to Fig. 4-51)
3. Move the Roller "S", "T" Guide Ass'y to slot and then lift it to remove. (Refer to arrow)

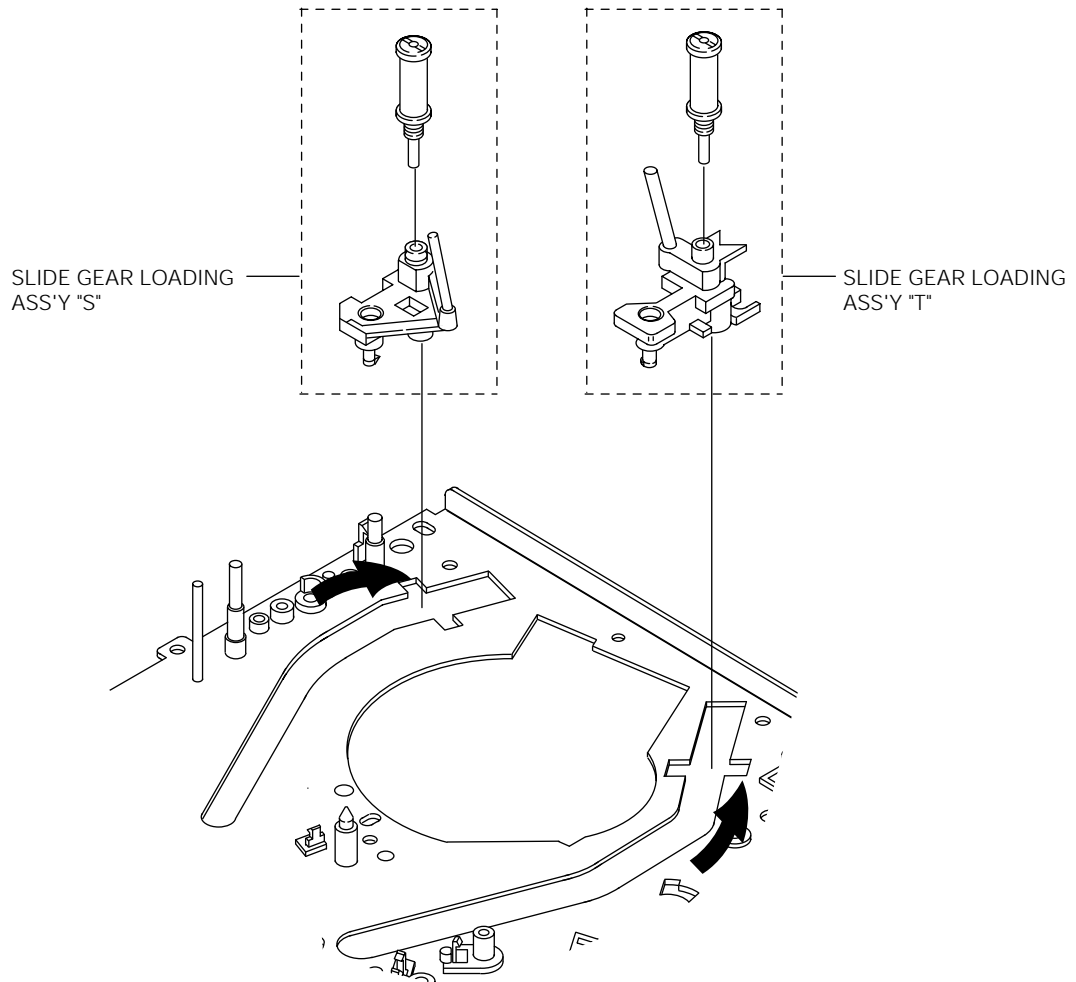

Fig. 4-58 Slide Guide Roller "S", "T" Ass'y Removal

4-4-40 Assembly of Guide Roller Slides "S", "T" Ass'y (When all parts except the Cylinder Ass'y are removed.)

1. Push 4 Lever Locks ① of the Housing Ass'y Simultaneously. (Refer to Fig. 4-59)
2. Push the Cassette Ass'y Holder ③ toward arrow "B" while turning the Master Gear ② toward arrow "A".
(Refer to Fig. 4-59)
3. Load the Loading L, R Gear Ass'y ④, ⑤ to the middle position of Guide Rail by turning the Master Gear ② toward arrow "A". (Refer to Fig. 4-59, 4-60)
4. Install the Guide Roller S, T Slide ⑥, ⑦ into the Rail slot and then move it to the position of Loading Gear L, R Ass'y ④, ⑤. (Refer to Fig. 60)
5. Turn the Master Gear ② toward arrow "A". (Eject mode)

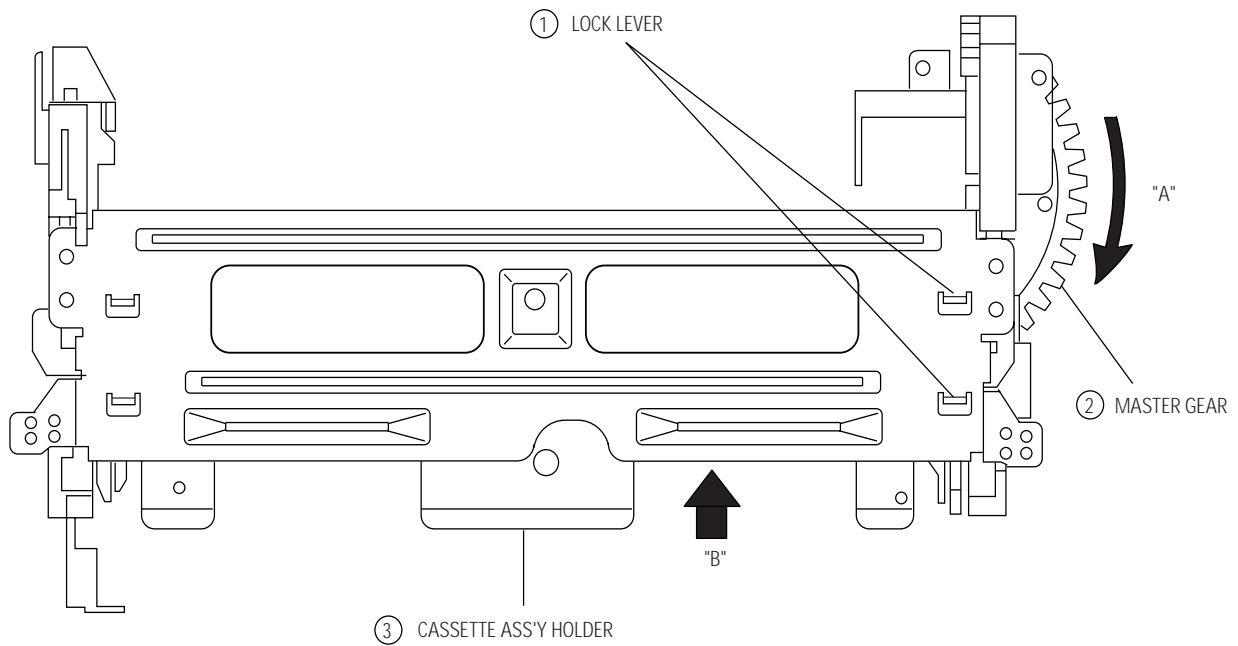

Fig.4-59 How to operate the Housing Ass'y

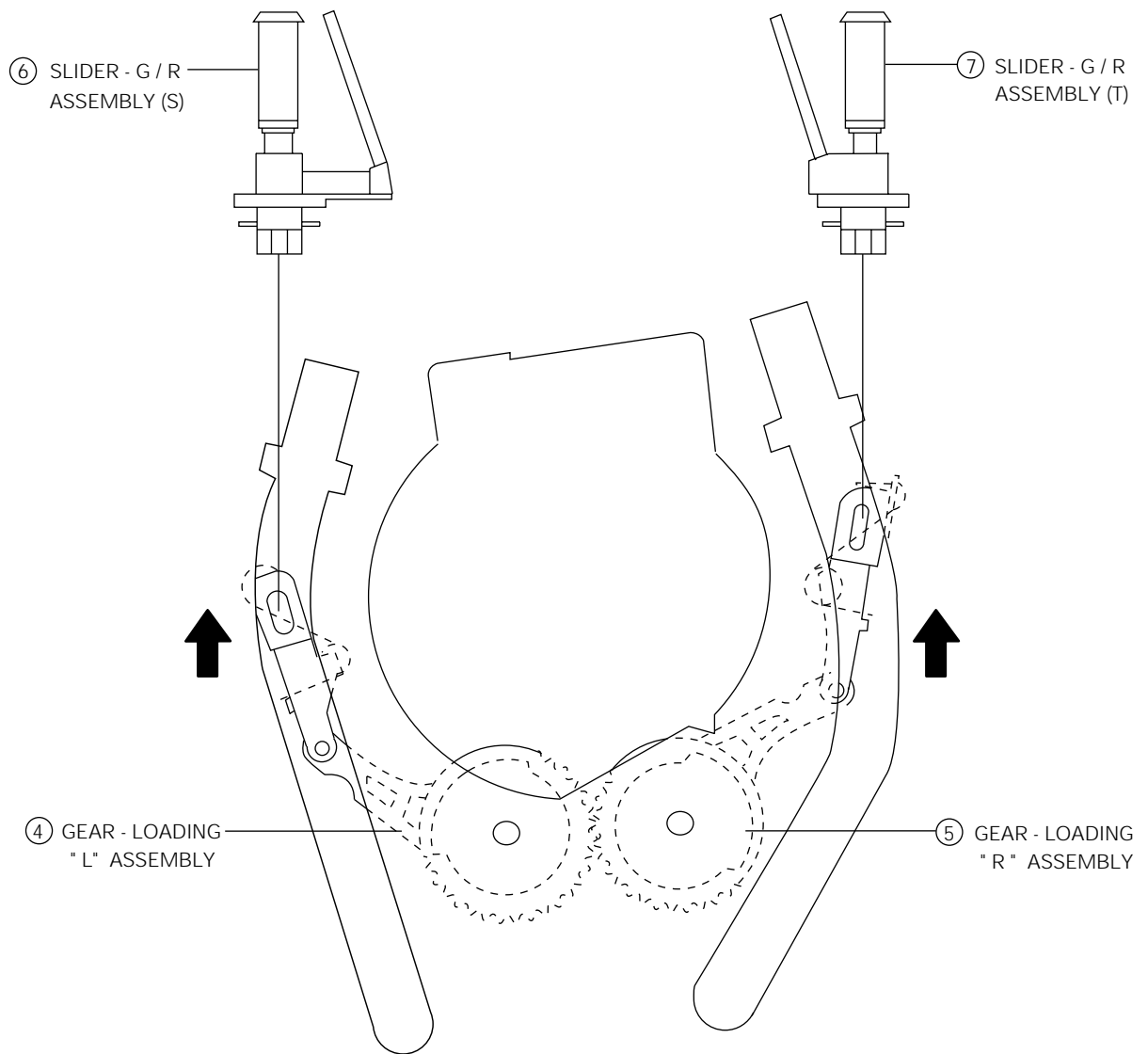

Fig. 4-60 Assembly of Guide Roller Slides "S" and "T"

4-5 Cleaning and Lubrication

4-5-1 Cleaning Tape Mechanism

Periodic cleaning of the tape mechanism is necessary. To clean the following parts, use patch and solvent :

1. Capstan Shaft
2. All tape guide posts
3. Clutch Pulley
4. Pinch roller
5. Belt Capstan
6. Capstan Motor Pulley

4-5-2 Cleaning of Rotating and Stationary Heads

To clean video heads, full erase head, and the audio/control (A/C) head use a head cleaning kit and solvent.

Note : When cleaning video heads, move the cleaning stick in the direction of head rotation (wiping in a vertical direction may damage the heads.)

Press a chamois cloth which has been dipped in cleaning fluid lightly against the rotating Cylinder Ass'y. Clean slowly by rotating the Upper Cylinder Ass'y by hand.

Note : Never turn the Motor on when cleaning.

4-5-3 Lubrication of Tape Mechanism

The tape transport mechanism is properly lubricated at the factory. In normal use cycles, and with average environmental conditions, additional lubrication should not be required during the first year of operation.

Depending on the frequency of use and environmental conditions, periodic lubrication may be required. When lubricating, first remove the old lubricant, then sparingly apply new lubricant. Excessive lubricant is transferred to other assemblies, malfunction will result.

Use grease on the following parts every 1,000 hours. (See exploded view for location) :

1. Between base pole assembly (L, R) and main base
2. Gear Loading L, R
3. Slide Main
4. Lever Shift
5. Gear Master
6. Lever Slide Pinch
7. Pinch Roller
8. Slide Pinch
9. Base Cylinder

Oil may be required for the following parts after 1,000 hours. (See exploded view for location) :

Main Base

1. Arm Tension molding
2. Shaft Reel Disk L, R
3. Shaft Gear Relay S, T
4. Shaft Idler
5. Shaft Clutch

Other parts which are not listed above do not require lubrication, except when parts are replaced. Use appropriate oil or grease as indicated on the exploded view.

THE ASSEMBLY PROCEDURE FOR DECK PARTS

NO	DESCRIPTION	SUBPARTS	LOCATE	REMARK
1	BASE MAIN ASS'Y	GREASE	TOP VIEW	
2	MOTOR D.D CAPSTAN	3 SCREWS	TOP VIEW	
3	LEVER JOG ASS'Y	1 SCREW	TOP VIEW	DX8-A/DX8-AC
4	GEAR RELAY "S" ASS'Y	1 WASHER SLIT	TOP VIEW	
5	GEAR RELAY "T" ASS'Y	1 WASHER SLIT	TOP VIEW	
6	IDLER ASS'Y	1 WASHER SLIT	TOP VIEW	
7	REEL DISK "L" ASS'Y	1 WASHER PLAIN	TOP VIEW	
8	REEL DISK "R" ASS'Y	1 WASHER PLAIN	TOP VIEW	
9	ARM TENSION FULL ASS'Y		TOP VIEW	
10	SLIDE G/R ASS'Y (S)		TOP VIEW	
11	SLIDE G/R ASS'Y (T)		TOP VIEW	
12	SLIDE PUSH		TOP VIEW	
13	SLIDER PINCH	GREASE	TOP VIEW	
14	GEAR LOADING "L" ASS'Y		BOTTOM VIEW	
15	GEAR LOADING "R" ASS'Y		BOTTOM VIEW	
16	LEVER IDLER CHANGE		BOTTOM VIEW	
17	LEVER SHIFT ASS'Y	SPRING GUIDE	BOTTOM VIEW	
18	SLIDER MAIN	1 WASHER SLIT	BOTTOM VIEW	
19	LEVER SLIDER PINCH	1 WASHER SLIT	BOTTOM VIEW	
20	CLUTCH ASS'Y	1 WASHER SLIT, PLAIN	BOTTOM VIEW	
21	BRAKE CAPSTAN ASS'Y		BOTTOM VIEW	
22	SPRING BRAKE CAPSTAN		BOTTOM VIEW	
23	UNIT LOADING	2 SCREWS	BOTTOM VIEW	
24	GEAR MASTER	1 WASHER SLIT	BOTTOM VIEW	
25	BELT CAPSTAN		BOTTOM VIEW	
26	LEVER REVIEW		TOP VIEW	
27	ARM REVIEW ASS'Y		TOP VIEW	
28	LEVER PINCH CAM		TOP VIEW	
29	LEVER PINCH COMP ASS'Y		TOP VIEW	
30	SPRING ARM PINCH		TOP VIEW	
31	UNIT PINCH ROLLER	1 WASHER SLIT	TOP VIEW	
32	BRAKE MAIN "L" ASS'Y		TOP VIEW	
33	BRAKE MAIN "R" ASS'Y		TOP VIEW	
34	SPRING BRAKE MAIN		TOP VIEW	
35	BRAKE SUB "L" ASS'Y		TOP VIEW	
36	BRAKE SUB "R" ASS'Y		TOP VIEW	
37	SPRING BRAKE SUB "L"		TOP VIEW	
38	SPRING BRAKE SUB "R"		TOP VIEW	

NO	DESCRIPTION	SUBPARTS	LOCATE	REMARK
39	PRISM LED		TOP VIEW	
40	SLIDER RACK HOUSING		TOP VIEW	
41	LEVER REC S/W		TOP VIEW	
42	SPRING REC S/W		TOP VIEW	
43	SPRING TENSION		TOP VIEW	
44	SPRING SLIDE PUSH		TOP VIEW	
45	MAGNET ACE HEAD ASS'Y	1 SCREW	TOP VIEW	
46	HOUSING ASS'Y	3 SCREWS	TOP VIEW	
47	CYLINDER ASS'Y	3 SCREWS	TOP VIEW	
48	MAGNET F/E HEAD	1 SCREW	TOP VIEW	

4-6 Tape Transport System and Adjustment Locations

The tape transport system has been adjusted precisely in the factory. Alignment is not necessary except for the following :

1. Noise observed on the screen.
2. Tape damage.
3. Parts replacement in the tape transport system.

Lower flange height of tape guide is used as the reference for the transport adjustment.

To maintain the height of the tape guide and prevent damage, do not apply excessive force onto the main base.

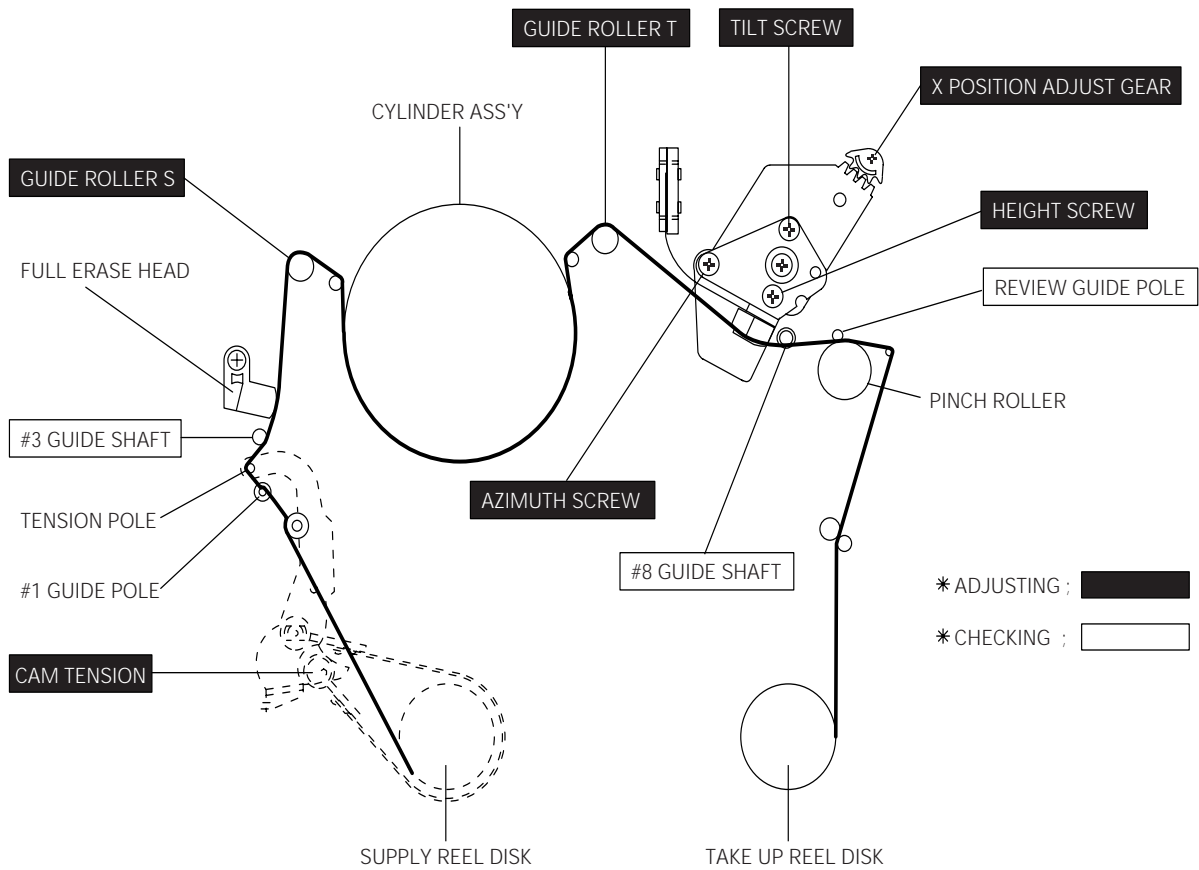

Fig. 4-61 Location of Tape Transport Adjustment

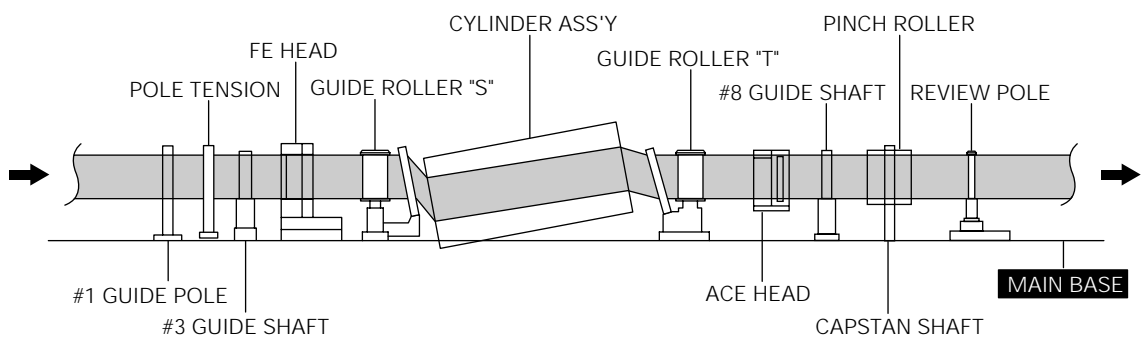

Fig. 4-62 Tape Travel Diagram

4-7 Tape Transport System Adjustment

When parts are replaced, perform the required adjustments by referring to precedures for the tape transport system. If there are any changes to the tape path, first run a T-120 (E-180) tape and make sure excessive tape wrinkle does not occur at the tape guides.

1. If tape wrinkle is observed at the S, T-guide rollers, turn the S, T-guide rollers until wrinkle disappears.
2. If the tape wrinkle is still observed at the tape guide, perform the tilt adjustment of the A/C head.
(See page 5-1 of the Service Manual for Test Point Locations.)

4-7-1 A/C Head Assembly Adjustment

4-7-1 (a) A/C HEAD HEIGHT ADJUSTMENT

1. Run the alignment tape (Color bar) in the playback mode.
2. Observe surface of the audio head using a dental mirror.
3. Turn screw (A), (B), (C) clockwise or counterclockwise until the gap of lower tape edge and the lower edge of the control head is about 0.25 mm. (Refer to Fig. 4-3 and 4-4)

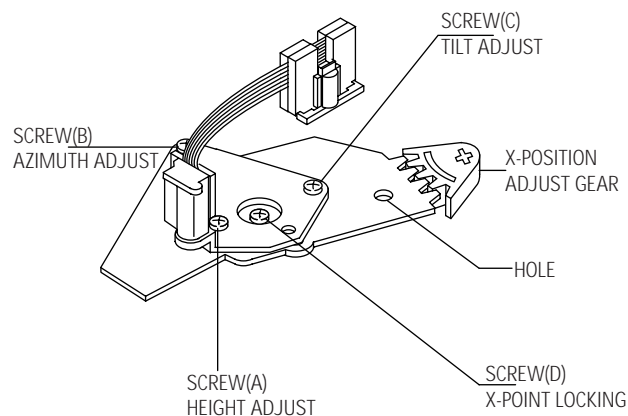

Fig. 4-63 Location of A/C Head Adjustment Screw

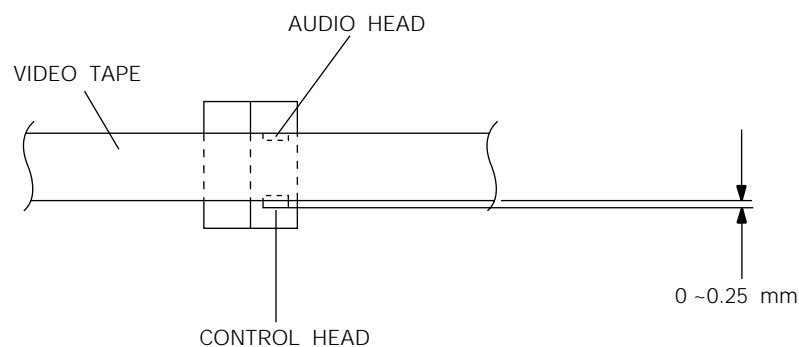

Fig. 4-64 A/C Head Height Adjustment

4-7-1 (b) A/C HEAD TILT ADJUSTMENT

1. Play back a T160 (E-240) tape and observe the position of the tape at the lower flange of tape guide.
2. Confirm that there is no curl or wrinkle at the lower flange of tape guide as shown in Fig.2- 5 (B)
3. If a curl or wrinkle of the tape occurs, slightly turn the screw (C) tilt adjust on the A/C Head ass'y.
4. Reconfirm the A/C head height.

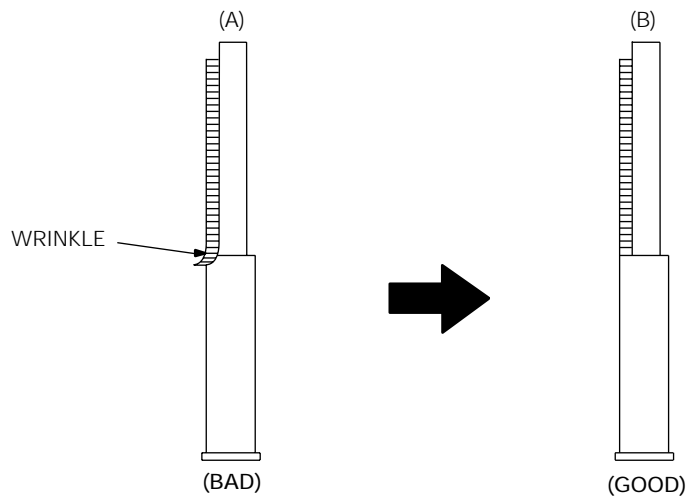

Fig. 4-64 Tape Guide Check

4-7-1 (c) AUDIO AZIMUTH ADJUSTMENT

1. Load alignment tape (Mono scope) and playback the NTSC : 7KHz (PAL : 6KHz) signal.
2. Connect channel-1 scope probe to audio output test point.
3. Adjust screw (B) to achieve maximum audio level (See Fig. 4-3).

4-7-1 (d) A/C HEAD POSITION (X-POINT) ADJUSTMENT

1. See page 5-2 of the Service Manual for A/C Head position (X-Point) adjustment.

4-7-2 Linearity adjustment (S, T-guide rollers adjustment)

1. Play back the Mono Scope alignment tape (SP mode).
2. Observe the video envelope signal on an oscilloscope (triggered by the video switching pulse).
3. Make sure the video envelope waveform (at its minimum) meets the specification shown in Fig. 4-65.
If it does not, adjust as follows :

Note : a=Maximum output of the video RF envelope.
 b=Minimum output of the video RF envelope at the entrance side.
 c=Minimum output of the video RF envelope at the center point.
 d=Maximum output of the video RF envelope at the exit side.

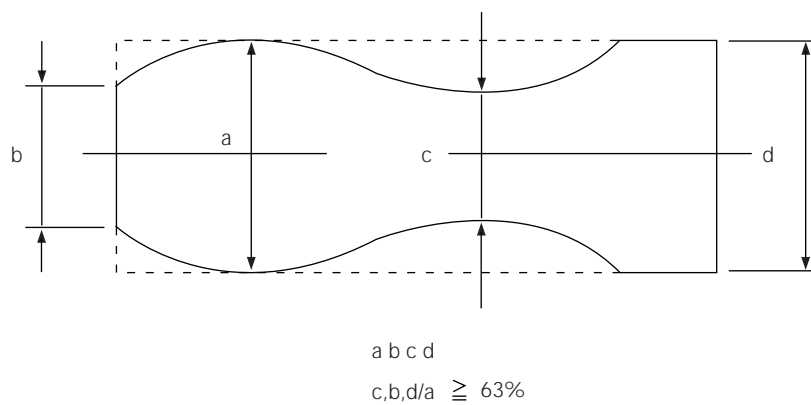

Fig. 4-65 Envelope Waveform Adjustment

4. If the section A in Fig. 4-66 does not meet the specification, adjust the S-guide roller up or down.
5. If the section B in Fig. 4-66 does not meet the specification, adjust T-guide roller up or down.

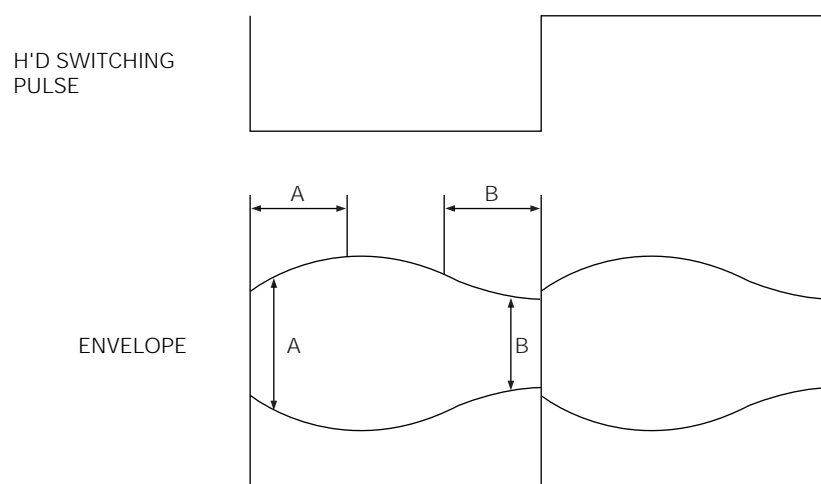



Fig. 4-66 Adjustment Points

6. Play back the Mono Scope alignment tape (SP mode).
7. Connect an oscilloscope CH-1 to the Envelope and CH-2 to the H'D SW Pulse for triggering.
8. Turn the guide roller heads with a flat head () driver to obtain a flat video RF envelope as shown in Fig. 4-67.
9. After the adjustment is completed, tighten the set screws.

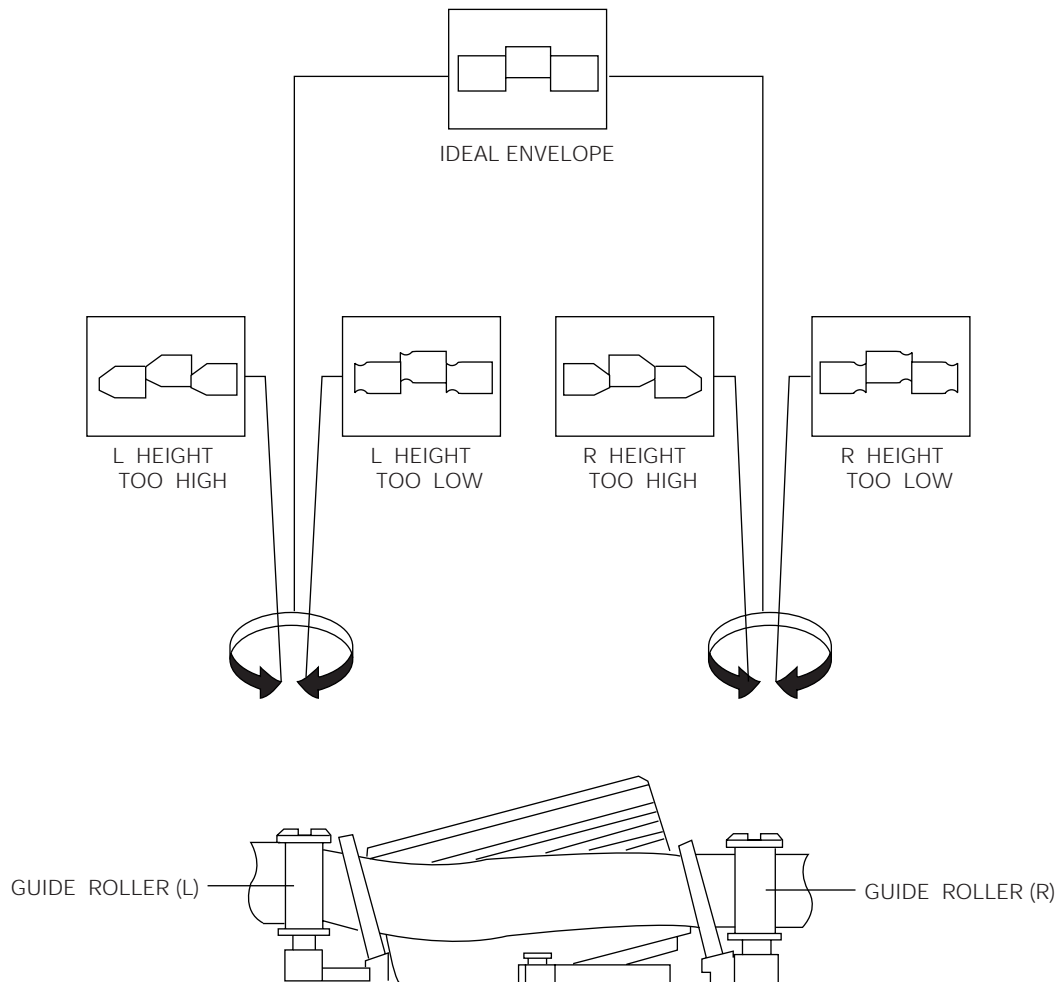

Fig. 4-67 S, T-Guide Roller Height Adjustment

4-7-3 Check Transitional Operation from RPS to Play

Check transition from RPS mode to play mode : Using a pre-recorded SP tape, make sure the entry side of envelope comes to an appropriate steady state within 3 seconds (as shown in Fig. 4-68). If the envelope waveform does not reach specified peak-to-peak amplitude within 3 seconds, adjust as follows :

1. Make sure there is no gap between the supply roller lower flange and the tape.
If there is a gap, adjust the supply guide roller again.
2. Change operation mode from the RPS to the play mode (again) and make sure the entry side of envelope rises within 3 second.

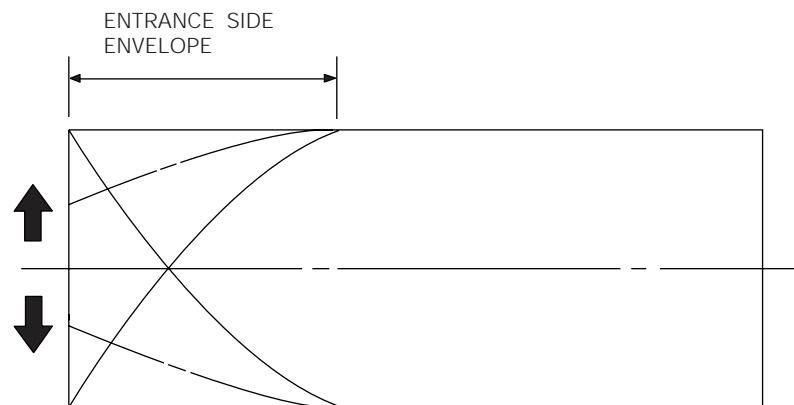

Fig. 4-68 Video Envelope Rising when Operation mode Changes from RPS to Play Mode

4-7-4 Envelope Check

1. Make recordings on T-120 (E-120) and T-160 (E-180) tape. Make sure the playback output envelope meets the specification as shown in Fig. 4-69.
2. Play back a self recorded tape (recording made on the unit using with T-120, E-120). The video envelope should meet the specification as shown in Fig. 4-69. In SP mode, (A) should equal (B). If the head gap is wide, upper cylinder should be checked.

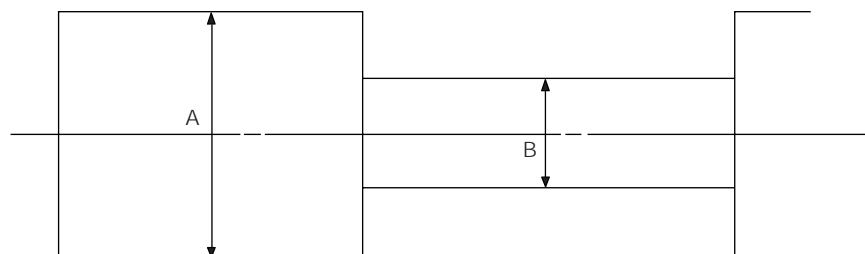

Fig. 4-69 Envelope Output and Output Level

4-7-5 Tape Wrinkle Check

1. Run the T-160 (E-240) tape in the playback, FPS, RPS and Pause modes and observe tape wrinkle at each guide.
2. If excessive tape wrinkle is observed, perform the following adjustments in Playback mode :
 - ◆ Tape wrinkle at the S, T-guide roller section : Linearity adjustment.
 - ◆ Tape wrinkle at tape guide flange : A/C head assembly coarse adjustment.

4-8 Reel Torque

4-8-1 Reel Torque

1. The rotation of the capstan motor drives the clutch ass'y through the capstan motor belt.
2. Brake operation and shift operation in FF/REW are done by a leverslide.
3. Transportation of accurate driving force is done by gears (clutch ass'y).

Note : If the spec does not meet the followings specifications, replace the clutch ass'y and then recheck.

MODE	TORQUE g/cm	GAUGE
PB/REC	100 ± 30	Cassette Torquemeter
RPS	170 ± 30	Cassette Torquemeter
FF/REW	Minimum 600	Torque Gauge

4-8-2 Location of Tension Pole and Back Tension Adjustments

1. Remove the housing ass'y and set the deck to "PLAY" mode.
2. Adjust the tension cam to 0 ~ -0.5mm from the center of supply roller.
3. The back tension meter should read 41 ~ 51g.cm. (PAL : 40 ~ 47g.cm)

Counterclockwise : Torque UP
Clockwise : Torque DOWN

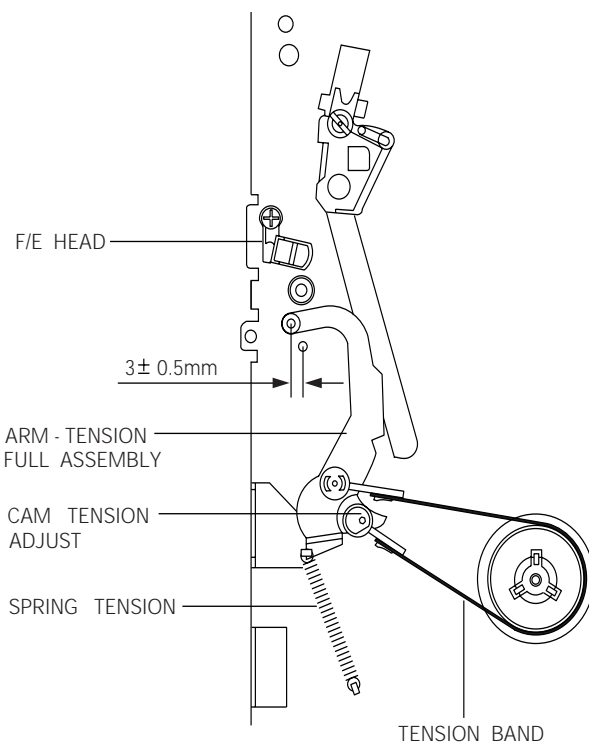

Fig. 4-70 Tension Pole and Back Tension Adjustment

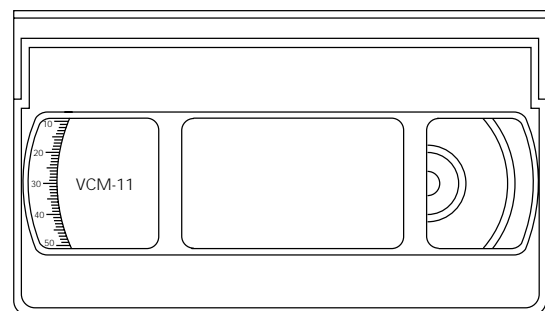

Fig. 4-71 Back Tension Tape Torque Cassette

5. Alignment and Adjustments (Electrical)

5-1 Preadjustment

5-1-1 Factory Mode

1. Do not attempt these adjustments in the Video Mode.
2. The Factory Mode adjustments are necessary when either the EEPROM (IC902) or the CRT is replaced.
3. Do not tamper with the "Adjustment" screen of the Factory Mode menu. This screen is intended only for factory use.

5-1-2 When EEPROM (IC902) Is Replaced

1. When IC902 is replaced all adjustment data revert to initial values. It is necessary to re-program this data.
2. After IC902 is replaced, warm up the TV for 10 seconds.

5-1-3 When CRT Is Replaced

1. Make the following adjustments AFTER setting up after setting up purity and convergence:
 - White Balance
 - Sub-Brightness
 - Vertical Center
 - Vertical Size
 - Horizontal Size
2. If the eeprom or CRT is replaced, set PSL and PVA to 15 and 63 (Factory Mode).

5-2 Factory ("Service") Mode

5-2-1 Procedure for the "Adjustment" Mode

1. This mode uses the standard remote control. The Service Mode is activated by: (1) pressing the "HIDDEN" service key on the local-keyboard, or (2) by entering the following remote-control sequence (within 2 seconds):

STAND-BY → P.STD → MENU → SLEEP → POWER ON
2. The "SERVICE (FACTORY)" message will be displayed. The Service Mode has these components: Adjustment, Option Bytes and Reset.
3. Access the Adjustment Mode by pressing the "VOLUME" keys (Up or Down). The adjustment parameters are listed in the accompanying table, and selected by pressing the CHANNEL keys (▲, ▼).
4. Selection sequences for the PAL/SECAM B/G, L systems:

down or up key:
AGC>VCO>LCO>SBT>SCT>SCR>RG>GG>BG>TCT>SC>PSL>PVS>PVA>PHS
5. For an NTSC tape or NTSC A/V input:

(use down or up keys):
AGC>VCO>SBT>SCT>SCR>STT>RG>GG>BG>SC>NSL>NVS>NVA>NHS
6. The VOLUME keys increase or decrease the adjustment values, (stored in the non-volatile memory when Adjustment Mode is cancelled).

5-2-2 Main Adjustment Parameters

Table 5-1 Main Adjustment Parameters (Sony μ -com) with TTX			
FUNCTION	OSD ABBREVIATION	RANGE	INITIAL DATA
AUTO GAIN CONTROL	AGC	0 - 63 STEP	43
SUB BRIGHT	SBT	0 - 13 STEP	6
SUB CONTRAST	SCT	0 - 13 STEP	6
SUB COLOR	SCR	0 - 13 STEP	6
SUB TINT	STT	0 - 13 STEP	9
RED CUTOFF	RC	0 - 63 STEP	38
GREEN CUTOFF	GC	0 - 63 STEP	32
BLUE CUTOFF	BC	0 - 63 STEP	33
TELETEXT CONTRAST	TCT	0 - 38 STEP	11
PAL VERTICAL SLOPE	PSL	0 - 63 STEP	28
PAL VERTICAL SHIFT	PVS	0 - 63 STEP	30
PAL VERTICAL AMPLITUDE	PVA	0 - 63 STEP	43
PAL HORIZONTAL SHIFT	PHS	0 - 63 STEP	33
NTSC VERTICAL SLOPE	NSL	0 - 63 STEP	29
NTSC VERTICAL SHIFT	NVS	0 - 63STEP	30
NTSC VERTICAL AMPLITUDE	NVA	0 - 63 STEP	39
NTSC HORIZONTAL SHIFT	NHS	0 - 63 STEP	46

NOTE : PVS, PVA, PHS, NVS, NVA, NHS parameters must be aligned using both the 50 Hz and 60 Hz vertical-field rates.

5-2-3 AGING Mode (Reference Only)

This pattern is used for pre-heating the CRT during manufacturing--it is accessed in the factory by twice pressing the "HIDDEN" key .

Even if the TV power is cut off, the Aging Mode is not cancelled, The patterns are displayed at 5 sec intervals. The AGING mode is cancelled by repressing the "HIDDEN" key.

5-2-4 Option

BIT	ITEM	0	1	REMARK
7	TTX	NO TTX	TTX	
6	TTX SYSTEM	LIST FIRST	FLOF FIRST	
5	CONTRAST	90	100	
4	TUNER QUANTITY	1	2	
3	TUNER KINDS	2889	0889	
2	SYSTEM (L)			
1	SYSTEM (D/K)			
0	SYSTEM (I)			

1. After an option is modified, the system must be reset in order for the change to take effect.
2. Bit 6 : TTX System. This bit reverts to its initial value during Power ON.
3. Bit 5 : After a "Factory Reset", the Contrast Option determines the contrast level during Memory Mode.
4. Bit 3 : Tuner Options:

BAND	TUNER	TECC2889PA19C	TECC0889PA19C
	VHF-L		40.00~171.75 MHz (E2~S10)
VHF-H		171.75~467.25 MHz (E5~S41)	150.75~467.25 MHz (S8~S41)
UHF		467.25~ (E21~)	467.25~900.00 MHz (E21~)

5. Bits 2,1,0 :

#2 (L)	#1 (D/K)	#0 (I)	AREA	COLOR SYSTEM	SOUND SYSTEM
0	0	0	WEST, SCAN	AUTO, PAL, SECAM	X
0	0	1	UNITED KINGDOM ®	AUTO, PAL	X
0	1	0	EAST,CIS	AUTO, PAL, SECAM	AUTO, B/G, D/K
0	1	1	CHINA, HONG KONG	AUTO, PAL, SECAM	AUTO, B/G, D/K, I
1	0	0	FRANCE	PAL/SECAM, FRANCE ®É	X
1	0	1	ITALY	AUTO, PAL	X
1	1	0	OCEANIA	AUTO PAL	X
1	1	1	NOT USED (DEFAULT OPERATION = WEST, SCAN)		

Note1: United Kingdom: 468 - 900MHz (UHF only)

Others: 40 - 900 MHz

Note2: Color decoder mode is always "auto"

SYSTEM	MODULATION STANDARD	COLOUR DECODER MODE
PAL/SECAM	NEGATIVE	AUTO
FRANCE	POSITIVE	AUTO

5-2-5 Option 2

BIT	ITEM	0	1	REMARK
7	NOT USED			
6	NOT USED			
5	POWER ON AFT	ONCE	TWICE	
4	PDC	NO	YES	
3	VPS	NO	YES	
2	3.58 X-TAL	NO	YES	
1	VIDEO PLUS	NO	YES	
0	SHOWVIEW	NO	YES	

Notes:

Bit 5 : Power On AFT: When this bit=1, the AFT will re-start automatically (unless a key is pressed within 5 seconds of power ON).

Bits 4, 3 : VPS and VDC cannot exist simultaneously. (The same applies for VIDEO PLUS and SHOWVIEW)

5-2-6 VCR Option

BIT	ITEM	0	1	REMARK
7	NOT USED			
6	NOT USED			
5	NOT USED			
4	HEAD	2-HEAD	4-HEAD	
3	SP/LP	SP ONLY	SP/LP	
2	SECAM	N/A	POSSIBLE	
1	MESECAM	N/A	POSSIBLE	
0	NTSC3.58	N/A	POSSIBLE	

5-3 Reset

The Reset Mode is used during factory inspection.

Function Reset : After Factory Reset, the following items revert to their initial values.

1. Volume 0
2. Channel 0
3. P-STD MEMORY
4. Contrast-tint MEMORY
5. Auto Power OFF
6. NR OFF
7. Reserved Timer Recording ALL CLEAR
8. Skip (Store/Clear) ALL CLEAR

Caution : When the EEPROM is replaced, all items revert to their initial values.

5-4 Other Adjustments

5-4-1 General

1. Usually, a color TV needs only slight touch-up adjustment upon installation. Check the basic characteristics such as height, horizontal and vertical sync and focus.
2. The picture should have good black and white details. There should be no objectionable color shading; if color shading is present, perform the purity and convergence adjustments described below.
3. Use the specified test equipment or its equivalent.
4. Correct impedance matching is essential.
5. Avoid overload. Excessive signal from a sweep generator might overload the front-end of the TV. When inserting signal markers, do not allow the marker generator to distort test results.
6. Connect the TV only to an AC power source with voltage and frequency as specified on the backcover nameplate.
7. Do not attempt to connect or disconnect any wires while the TV is turned on. Make sure that the power cord is disconnected before replacing any parts.
8. To protect against shock hazard, use an isolation transformer.

5-4-2 Automatic Degaussing

A degaussing coil is mounted around the picture tube, so that external degaussing after moving the TV should be unnecessary. But the receiver must be properly degaussed upon installation.

The degaussing coil operates for about 1 second after the power is switched ON. If the set has been moved or turned in a different direction, disconnect its AC power for at least 10 minutes.

If the chassis or parts of the cabinet become magnetized, poor color purity will result. If this happens, use an external degaussing coil. Slowly move the degaussing coil around the faceplate of the picture tube and the sides and front of the receiver. Slowly withdraw the coil to a distance of about 6 feet before removing power.

5-4-3 High Voltage Check

CAUTION: There is no high voltage adjustment on this chassis. The B+ power supply must be set to +125 volts (Full color bar input and normal picture level).

1. Connect a digital voltmeter to the second anode of the picture tube.
2. Turn on the TV. Set the Brightness and Contrast controls to minimum (zero beam current).
3. The high voltage should not exceed 27.5KV.
4. Adjust the Brightness and contrast controls to both extremes. Ensure that the high voltage does not exceed 27.5KV under any conditions.

5-4-4 FOCUS Adjustment

1. Input a black and white signal.
2. Adjust the tuning control for the clearest picture.
3. Adjust the FOCUS control for well defined scanning lines in the center area of the screen.

5-4-5 Screen Adjustment

1. Turn to the ACTIVE channel.
2. Adjust the VR screen for a normal picture is (no blooming or flyback line).
3. Adjust the FOCUS control for well defined scanning lines in the center area of the screen.

5-4-6 Purity Adjustment

1. Warm up the receiver for at least 20 minutes.
2. Plug in the CRT deflection yoke and tighten the clamp screw.
3. Plug the convergence yoke into the CRT and set in as shown in Fig. 5-1.
4. Input a black and white signal.
5. Fully demagnetize the receive by applying an external degaussing coil.
6. Turn the CONTRAST and BRIGHTNESS controls to maximum.
7. Loosen the clamp screw holding the yoke. Slide the yoke backward or forward to provide vertical green belt. (Fig. 5-2).
8. Tighten the convergence yoke.
9. Slowly move the deflection yoke forward, and adjust for the best overall green screen.
10. Temporarily tighten the deflection yoke.
11. Produce blue and red rasters by adjusting the low-light controls. Check for good purity in each field.
12. Tighten the deflection yoke.

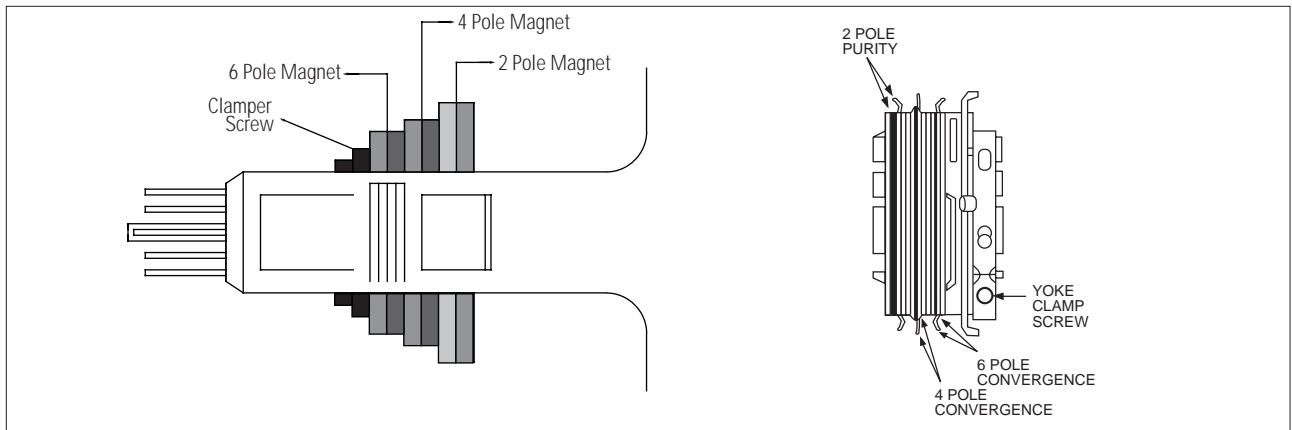

Fig. 5-1 Convergence Magnet Assembly

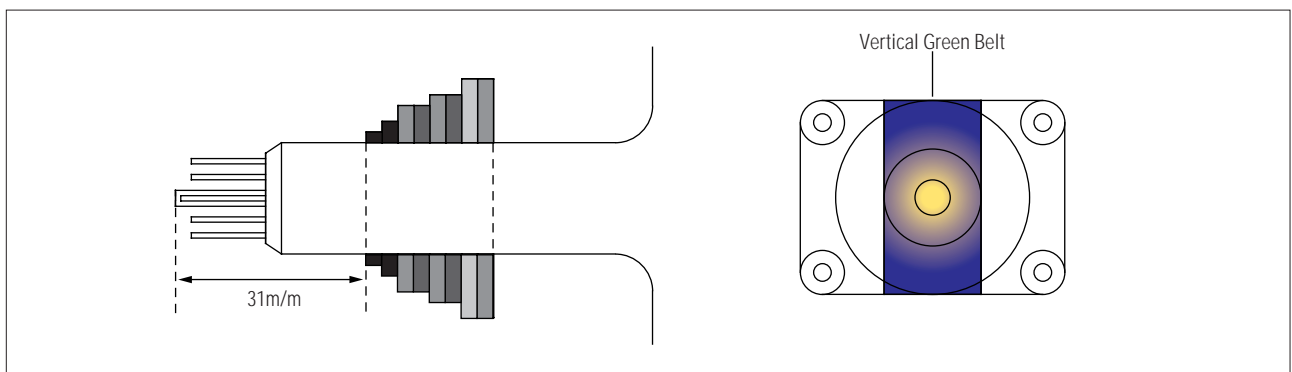

Fig. 5-2 Center Convergence Adjustment

5-4-7 White Balance Adjustment

5-4-7 (A) HIGH-LIGHT ADJUSTMENT

1. Input either a Lion Head or a "pure white" pattern.
2. Warm up the TV for 30 minutes.
3. Check the data in the Service Mode
4. Adjust RG, BG in the Factory Mode.

5-4-7 (B) LOW-LIGHT ADJUSTMENT

1. Automatically accomplished during the high-light adjustment.

5-4-8 Center Convergence Adjustment

1. Warm up the receiver for at least 20 minutes.
2. Adjust the two tabs of the 4 pole magnets to change the angle between them. Superimpose the red and blue vertical lines in the center area of the screen.
3. Adjust the Brightness and Contrast controls for a well defined picture.
4. Adjust the two-tab pairs of the 4 pole magnets, and change the angle between them. Superimpose the red and the blue vertical lines in the center area of the screen.
5. Turn the both tabs at the same time, keeping the angle constant, and superimpose the red and blue horizontal line in the center of the screen.
6. Adjust the two-tab pairs of the 6-pole magnets to superimpose the red and blue line onto the green. (Changing the angle affects the vertical lines, and rotating both magnets affects the horizontal lines.)
7. Repeat adjustments 2~6, if necessary.
8. Since the 4-pole magnets and 6-pole magnets interact, the dot movement is complex (Fig. 5-3).

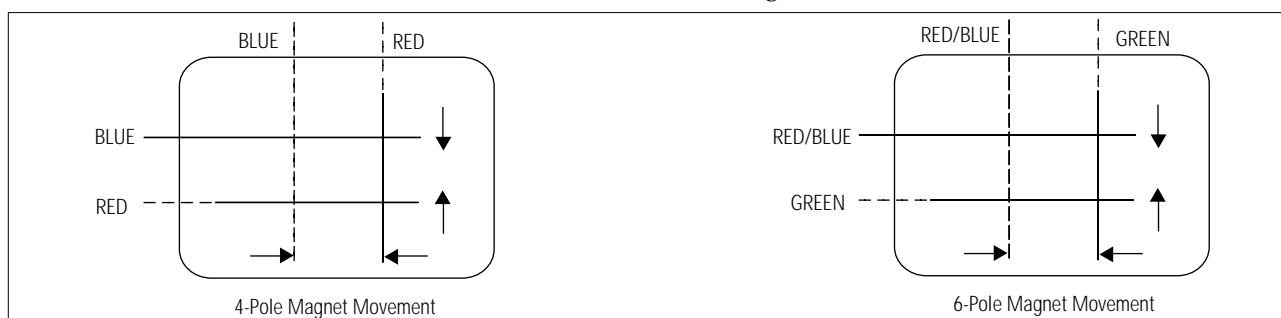

Fig 5-3 Center Convergence Adjustment

5-4-9 VCO Adjustment

1. Apply an IF input (38.9MHz) signal.
2. In Factory Mode, adjust the AFC with the VCO tuning bits (AFA, AFB).

The VCO is correct when the AFA Bit is "INSIDE WINDOW".

(The AFB Bit is above~below). The AFC output is available on the I²C-BUS (used for VCO Adjustment and feedback).

5-4-10 LCO Adjustment

1. Apply an IF input (33.9) MHz signal.
2. Set the system to FRANCE.
3. In Factory Mode, adjust the AFC with the LCO tuning bits (AFA, AFB).

The LCO is correct when the AFA Bit is

"INSIDE WINDOW"(The AFB Bit is above~below). The AFC output is available on the I²C-BUS (used for LCO Adjustment and feedback).

5-4-11 RF AGC Adjustment

1. Input a UHF High channel (80dB, 479.25 MHz).
2. Set the AGC in the Factory mode.
3. Set Pin 53 of IC201 (TDA8374) to $3.6V \pm 0.05V$ (DC).

5-4-12 Dual Tuner AFT Adjustment (France)

Test Equipment

1. TV Generator (PM5518,PM5418,ETC.)
2. DC VOLTMETER

1. Store 63.75 MHz in P00 (France System).
2. Store 48.25 MHz in P01 (PAL/SEC System).
3. Connect DC Voltmeter to AFT terminal of 2-tuner IF-module.
4. After selecting P00, input to TU002 IF1 (34.3 MHz).
5. After selecting P00, set to 3V (using MT01).
6. After selecting P01, input to TU002 IF1 (38.9 MHz).
7. After selecting P01, set to 3V (using MT02).
8. After reselecting P00, connect 34.3 MHz signal to TU002 IF1, and then check the voltage of AFT ($3V \pm 0.05V$). If the adjustment voltage is out of specification, redo 4~7.

5-4-13 Dual Tuner AFT Adjustment (PAL/SECAM B/G,I,D/K)

1. Store 471.25MHz in P00.
2. Connect DC Voltmeter to AFT terminal of TUNER IF-MODULE.
3. After selecting P00, input to IF1 terminal of TU002 (38.9 MHz)
4. After selecting P00, set to 3V (using MT01).

5-5 Electrical Adjustment (VCR Section)

5-5-1 Preparation

Electrical adjustments are required after replacing circuit components and certain mechanical parts. It is important to perform these adjustment only after all repairs and replacements have been completed. Also, do not attempt these adjustments unless the proper equipment is available.

5-5-2 Required Test Equipment

1. Color Television or Monitor
2. Oscilloscope : Wide-band, dual-trace, triggered delayed sweep.
3. DC Voltmeter
4. TV CH Generator
5. Attenuator
6. Recording tape. (Blank tape)
7. Pattern Generator : PAL color bar. 100% White.

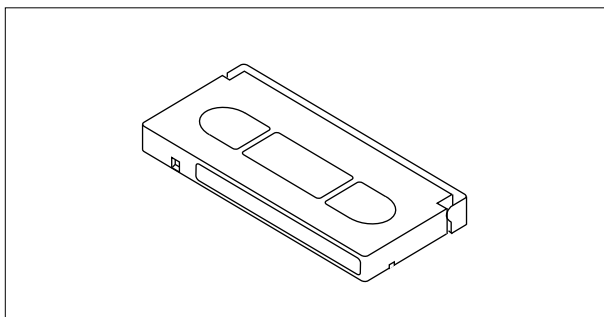

Fig. 5-4 Alignment Tape

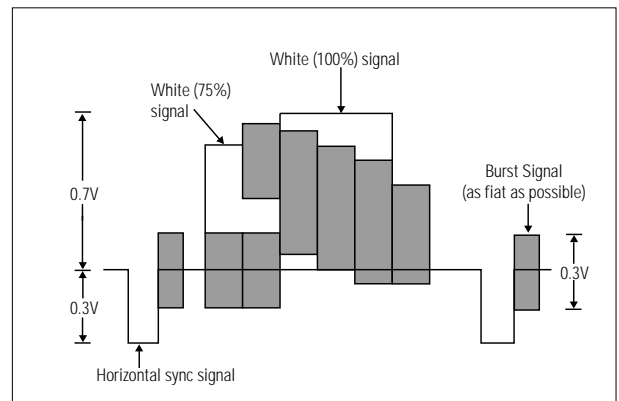

Fig. 5-5 Color bar signal of pattern generator

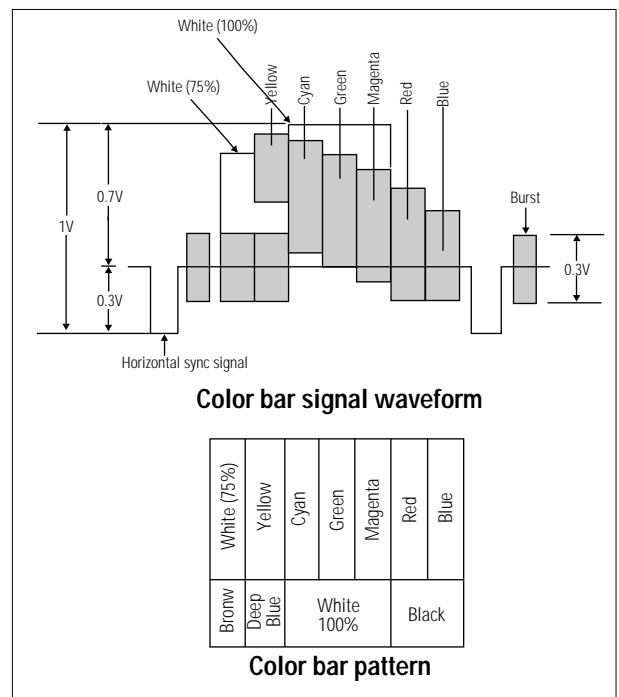
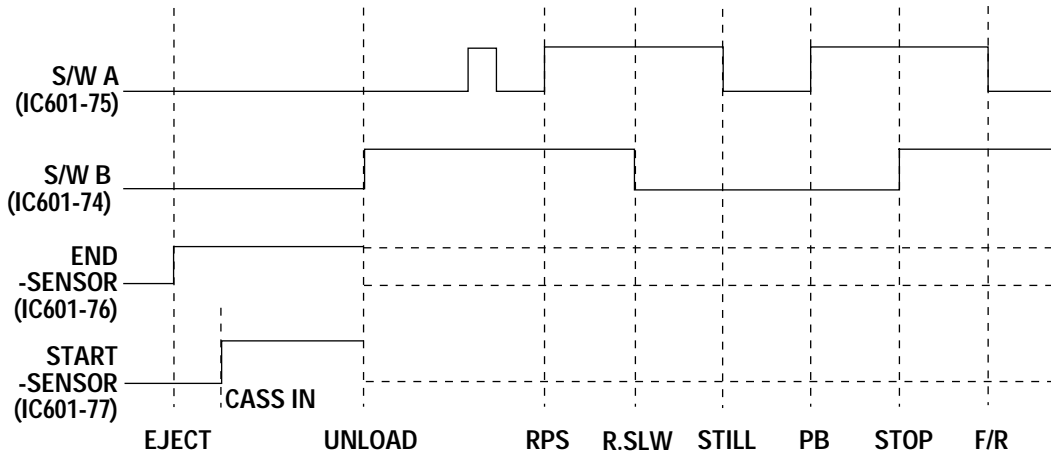

Fig. 5-6 Color bar signal of alignment tape (75% Color Bars)

5-5-3 Timing Chart of Program S/W



POSITION	PROGRAM S/W (SW601)				ACTION MODE
	E/S	S/S	S/W A	S/W B	
EJECT	L	L	L	L	EJECT
CASS IN	H	L H	L	L	CASS IN
UNLOAD	-	-	L	L H	UNLOAD
R.PS	-	-	L H	H	R.PS, Z-R.PS
R.SLOW	-	-	H	H L	PINCH ROLLER OFF POSITION
STILL	-	-	H L	L	STILL, SLOW, F-ADV
PLAY	-	-	L H	L	PB,T-STOP,REC, PAUSE, F.PS, Z-FPS
STOP	-	-	H	L H	STOP, POWER OFF
FF/REW	-	-	H L	H	FF, REW

5-6 Module Deck Adjustment Process

5-6-1 H'D S/W Point Adjustment:

1. Load alignment tape (PAL signal, SPC-SD).
2. Connect oscilloscope, CH-1 to TP201 (H'D S/W pulse), & CH-2 to TP302 (Video out)
3. Adjust VR201 (H'D S/W pulse) so that the waveform looks like the one shown below:

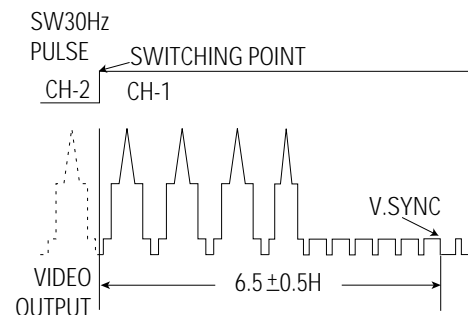

5-6-2 OPTION TABLE (Continued)

N	LOCA-NO	CODE NO	Description	Spec.	MODEL												Remark
					340FK/ SEF-S	340WK/ BWX-C	340WKD/ SEF-C	340WKD/ EGC-C	320FK/ SEF-S	320XK/ SEG-C	320K/UK -C	320WK/ BWX-C	320WKD/ BWX-C	320WKD/ EGC-C			
18	CM430	2202-000205	C	220	0	0	0	0	X	X	X	X	X	X	X	4HD	
19	JPM301	3812-000219		JUMPER	X	X	X	X	0	0	0	0	0	0	0	2HD	
20	JPM402	3812-000219		JUMPER	X	X	X	X	0	0	0	0	0	0	0	2HD	
21	DM401	0401-000005	D	1N4148	0	0	0	0	X	X	X	X	X	X	X	4HD	
22	RM345	2001-000554	R	270	X	X	X	X	X	X	0	X	X	X	X	2HD LP	
23	CM311	0504-000119	TR	R1004	X	X	X	X	X	X	0	X	X	X	X	2HD LP	
24	JM178	3812-000219		JUMPER	0	0	0	0	X	X	X	X	X	X	X	4HD	
25	JM119	3812-000219		JUMPER	0	0	0	0	X	X	X	X	X	X	X	4HD	
26	JM120	3812-000219		JUMPER	0	0	0	0	X	X	X	X	X	X	X	4HD	
27	RM339	2001-000429	R	1K	0	0	0	0	0	0	X	0	0	0	0	MESECAM	
28	RM340	2001-000449	R	2.2K	0	0	0	0	0	0	X	0	0	0	0	MESECAM	
29	CM371	2202-000127	C	103	0	0	0	0	0	0	X	0	0	0	0	MESECAM	
30	JM060	3802-000219		JUMPER	0	0	0	0	0	0	X	0	0	0	0	MESECAM	
31	JM138	3802-000219		JUMPER	0	0	0	0	0	0	X	0	0	0	0	MESECAM	
32	JM140	3802-000219		JUMPER	0	0	0	0	0	0	X	0	0	0	0	MESECAM	
33	JM198	3802-000219		JUMPER	X	0	0	0	X	0	0	0	0	0	0	NON- SECAM	
34	SECAM BLOCK				0	X	X	X	0	X	X	X	X	X	X		
35	DM617	0401-000005	D	1N4148	0	0	0	0	X	X	0	X	X	X	X	LP	
36	DM630	0401-000005	D	1N4148	X	0	0	0	X	X	X	0	0	0	0	NT3.58	
37	DM632	0401-000005	D	1N4148	0	X	X	X	0	X	X	X	X	X	X	SECAM	
38	DM704	0401-000005	D	1N4148	0	0	0	0	X	X	X	X	X	X	X	4HD	
39	DM703	0401-000005	D	1N4148	X	X	X	X	X	X	0	X	X	X	X	for 1K	
40	DM705	0401-000005	D	1N4148	0	0	0	0	0	0	0	0	0	0	0	PAL	
41	JM400	3812-000219		JUMPER	X	X	X	X	0	0	0	0	0	0	0	2HD	

5-6-2 OPTION TABLE (Continued)

NO	LOCA-NO	CODE NO	Description	Spec.	MODEL										Remark		
					340K/SEF-S	340WK/BWX-C	340WKD/SEF-C	340WKD/EGC-C	320K/SEF-S	320K/SEF-C	320K/UK-C	320WK/BWX-C	320WKD/BWX-C	320WKD/EGC-C			
42	JM401	3812-000219		JUMPER	0	0	0	0	0	X	X	X	X	X	X	X	4HD
43	JM404	3812-000219		JUMPER	0	X	X	X	0	X	X	X	X	X	X	X	SECAM
44	JM405	3812-000219		JUMPER	0	0	0	0	0	0	X	0	0	0	0	0	MSECA
45	JM406	3812-000219		JUMPER	0	X	X	X	0	0	0	X	X	X	X	X	NT PB
46	JM407	3812-000219		JUMPER	X	0	0	0	X	X	X	0	0	0	0	0	NT3.58
47	JM409	3812-000219		JUMPER	X	X	X	X	X	X	0	X	X	X	X	X	LP HEAD
48	CM668	2401-002259	C	0.1F	X	X	X	0	X	X	X	X	X	X	X	0	BACK-UP
49	RM662	2001-000458	R	2.2 1/8	X	X	X	0	X	X	X	X	X	X	X	0	BACK-UP
50	RM699	2001-000004	R	200K	X	X	X	0	X	X	X	X	X	X	X	0	BACK-UP
51	JPM302	3812-000219		JUMPER	0	0	0	0	0	0	0	0	0	0	0	0	PAL
52	JPM304	3812-000219		JUMPER	0	0	0	0	0	0	0	0	0	0	0	0	PAL
53	DM618	0401-000005	D	TN4148	AVV 1 CHIP IC is used for PAL(only). Multi IC is commonly used.												
54	DM702	0401-000005	D	TN4148	BI NOR specification applies to models (for South America).												
Specifications of M-320FK/SEF-C are as follows: ASSY M/DECK : AA94-80003L.D.ECK ASSY:AA91-40099A.PCB ASSY:AA96-80002D Specifications of OPTION are identical with ones of 320FK/SEF-S.																	
ASSY M/DECK	M/DECK Name	PCB ASSY	FULL DECK ASSY	Specification	Destination	Remark											
AA94-80003J	M-340FK/SEF-S	AA96-80002P	AA91-40100A	PAL/MESECAM/SECAM/NT PB ON PAL TV	BASIC France	PAL Areas											
AA94-80003K	M-320FK/SEF-S	AA96-80002D	AA91-40099A	PAL/MESECAM/SECAM/NT PB ON PAL TV	BASIC France												
AA94-80003L	M-320FK/SEF-C	AA96-80002D	AA91-40099A	PAL/MESECAM/SECAM/NT PB ON PAL TV	-												
AA94-8000M	M-320KX/SEG-S	AA96-80002S	AA91-40099A	PAL/MESECAM/NT PB ON PAL TV	Australia/Europe												
AA94-80003N	M-320K/UK-S	AA96-80002T	AA91-40101A	PAL/NT PB ON PAL TV(Only for LP HEAD)	United Kingdom												
AA94-80003P	M-320WK/BWX-S	AA96-80002U	AA91-40099A	PAL/MESECAM/NT3.58	Russia/Middle East												
AA94-80003Q	M-340WK/BWX-S	AA96-80002V	AA91-40100A	PAL/MESECAM/NT3.58	Russia/Middle East												
AA94-80003R	M-320WKD/BWX-S	AA96-80002U	AA91-40102A	PAL/MESECAM/NT3.58 DIAMOND	Russia/Middle East	D DRUM											
AA94-80003S	M-340WKD/BWX-S	AA96-80002V	AA91-40103A	PAL/MESECAM/NT3.58 DIAMOND	Russia/Middle East	D DRUM											
AA94-80003T	M-320WKD/EGC-S	AA96-80002W	AA91-40102A	PAL/MESECAM/NT3.58 (BACK-UP)	Libya	D DRUM											
AA94-80003U	M-340WKD/EGC-S	AA96-80002X	AA91-40103A	PAL/MESECAM/NT3.58 (BACK-UP)	Libya	D DRUM											

5-6-2 OPTION TABLE (Continued)

SECAM BLOCK LIST

NO	LOCA-NO	CODE NO	Description	Spec.	Remark
1		38 12-000219	JUMP	WIRE	add
2	JM109	38 12-000219	JUMP	"	"
3	JM113	38 12-000219	JUMP	"	"
4		38 12-000219	JUMP	"	"
5	JM115	38 12-000219	JUMP	"	"
6	JM116	38 12-000219	JUMP	"	"
7	JM111	38 12-000219	JUMP	"	"
8	JM089	38 12-000219	JUMP	"	"
9	QM901	05 01-000303	TR	A733	"
10	QM902	05 01-000303	TR	A733	"
11	QM903	05 01-000142	TR	R2001	"
12	QM904	05 01-000303	TR	A733	"
13	QM905	05 01-000398	TR	C945	"
14	CM901	22 02-000195	C	221	"
15	CM902	24 01-000620	C	2.2uF/50V	"
16	CM903	22 02-000127	C	103	"
17	CM904	22 02-000127	C	103	"
18	CM905	22 02-000109	C	104	"
19	CM906	22 02-000154	C	151	"
20	CM907	24 01-001496	C	47/16	"
21	CM908	22 02-000109	C	104	"
22	CM909	22 02-000127	C	103	"
23	CM910	22 02-000127	C	103	"
24	CM911	22 02-000127	C	103	"
25	CM912	22 02-000127	C	103	"
26	CM913	24 01-001333	C	0.47/50	"
27	CM914	22 02-000796	C	102	"
28	CM915	24 01-000455	C	10/35	"
29	CM916	22 02-000109	C	104	"
30	CM917	22 02-000127	C	103	"

5-6-2 OPTION TABLE (Continued)

NO	LOCA-NO	CODE NO	Description	Spec.	Remark
31	CM920	2202-000199	C	223	add
32	CM921	2401-000594	C	1/50	"
33	CM922	2202-000127	C	103	"
34	CM923	2202-002036	C	510	"
35	CM925	2202-000143	C	100	"
36	CM926	2202-000830	C	820	"
37	CM927	2202-000825	C	681	"
38	CM928	2202-000210	C	271	"
39	CM930	2202-000127	C	103	"
40	DM901	0401-000005	C	1N4148	"
41	ICM901	1204-001058	IC	LA7337	"
42	LM902	2701-000208	COIL	6.8uH	"
43	LM903	2701-000162	COIL	27uH	"
44	LM904	2701-000191	COIL	47uH	"
45	LM905	2701-000158	COIL	22uH	"
46	RM902	2001-000977	R	8.2K	"
47	RM903	2004-001995	R	9.1K	"
48	RM904	2001-000563	R	27K	"
49	RM905	2001-000786	R	47K	"
50	RM906	2001-000429	R	1K	"
51	RM907	2001-000890	R	6.8K	"
52	RM908	2001-000613	R	3.9K	"
53	RM909	2001-000660	R	33K	"
54	RM910	2001-000660	R	33K	"
55	RM911	2001-000837	R	51K	"
56	RM912	2001-000734	R	4.7K	"
57	RM913	2001-000633	R	30K	"
58	RM915	2001-000890	R	6.8K	"
59	RM916	2001-000472	R	2.7K	"
60	RM917	2001-000522	R	22K	"
61	RM918	2001-000429	R	1K	"
62	RM919	2001-000605	R	3.6K	"

5-6-2 OPTION TABLE (Continued)

NO	LOCA-NO	CODE NO	Description	Spec.	Remark
63	RM920	2001-000761	R	430	add
64	RM921	2004-001996	R	910	"
65	RM922	2001-000429	R	1K	"
66	RM923	2001-000539	R	24K	"
67	RM924	2001-000319	R	120K	"
68	RM925	2001-000258	R	1.8K	"
69	RM926	2001-000539	R	24K	"
70	RM927	2001-000947	R	7.5K	"
71	JPM303	3812-000219		JUMPER	"
72	JM024	3812-000219		JUMPER	"
73	JM028	3812-000219		JUMPER	"
74	JM035	3812-000219		JUMPER	"
75	QM630	0504-000144	TR	R2002	"
76	QM631	0504-000119	TR	R2001	"

5-6-2 OPTION TABLE (Continued)**OPTION TABLE (Attached On PCB and Not Used)**

NO	LOCA-NO	CODE NO	Spec.	Remark
1	CM342	2202-000295	C-CERAMIC;680,5%	Change of fixed number
2	CM352	2202-000121	C-CERAMIC;101,5%	Change of fixed number
3	CM419	2202-000127	C-CERAMIC;103,30%	Not Used
4	DM605	0401-000005	1N4148	Not Used
5	JM032	3812-000219	JUMPER	South America
6	JM034	3812-000219	JUMPER	"
7	JM051	3812-000219	JUMPER	"
8	JM053	3812-000219	JUMPER	"
9	JM061	3812-000219	JUMPER	"
10	JM139	3812-000219	JUMPER	"
11	JM142	3812-000219	JUMPER	"
12	JM150	3812-000219	JUMPER	"
13	JM157	3812-000219	JUMPER	Not Used
14	JPM305	3812-000219	JUMPER	PAL ONLY
15	JPM307	3812-000219	JUMPER	PAL ONLY
16	JPM308	3812-000219	JUMPER	PAL ONLY
17	JPM309	3812-000219	JUMPER	PAL ONLY
18	LM303	2702-000143	RADIAL;270UH,5%	Change of fixed number
19	LM306	2702-000143	RADIAL;270UH,5%	Change of fixed number
20	QM307	0504-000119	R1004	South America
21	RM304	2001-000273	100K,1/8	South America
22	RM320	2001-000800	5.1K,1/8	Change of fixed number
23	RM330	2001-000522	22K,1/8	South America
24	RM331	2001-000429	1K,1/8	South America
25	XTM303	2801-000241	3.582056MHZ	South America
26	XTM304	2801-000241	3.575611MHZ	South America

6. Troubleshooting

6-1 No Power (No LED on)

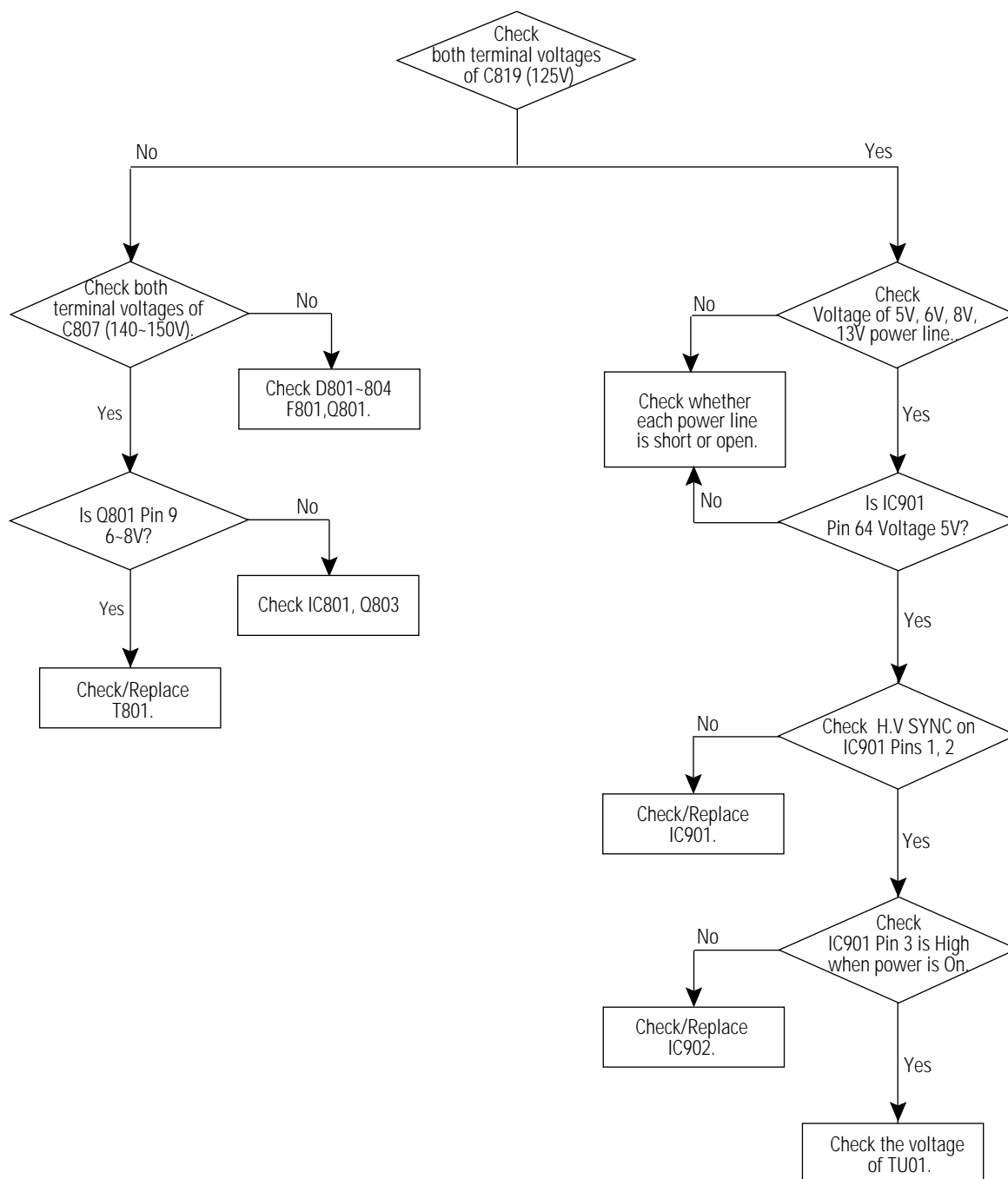

6-2 No Power (No Picture On)

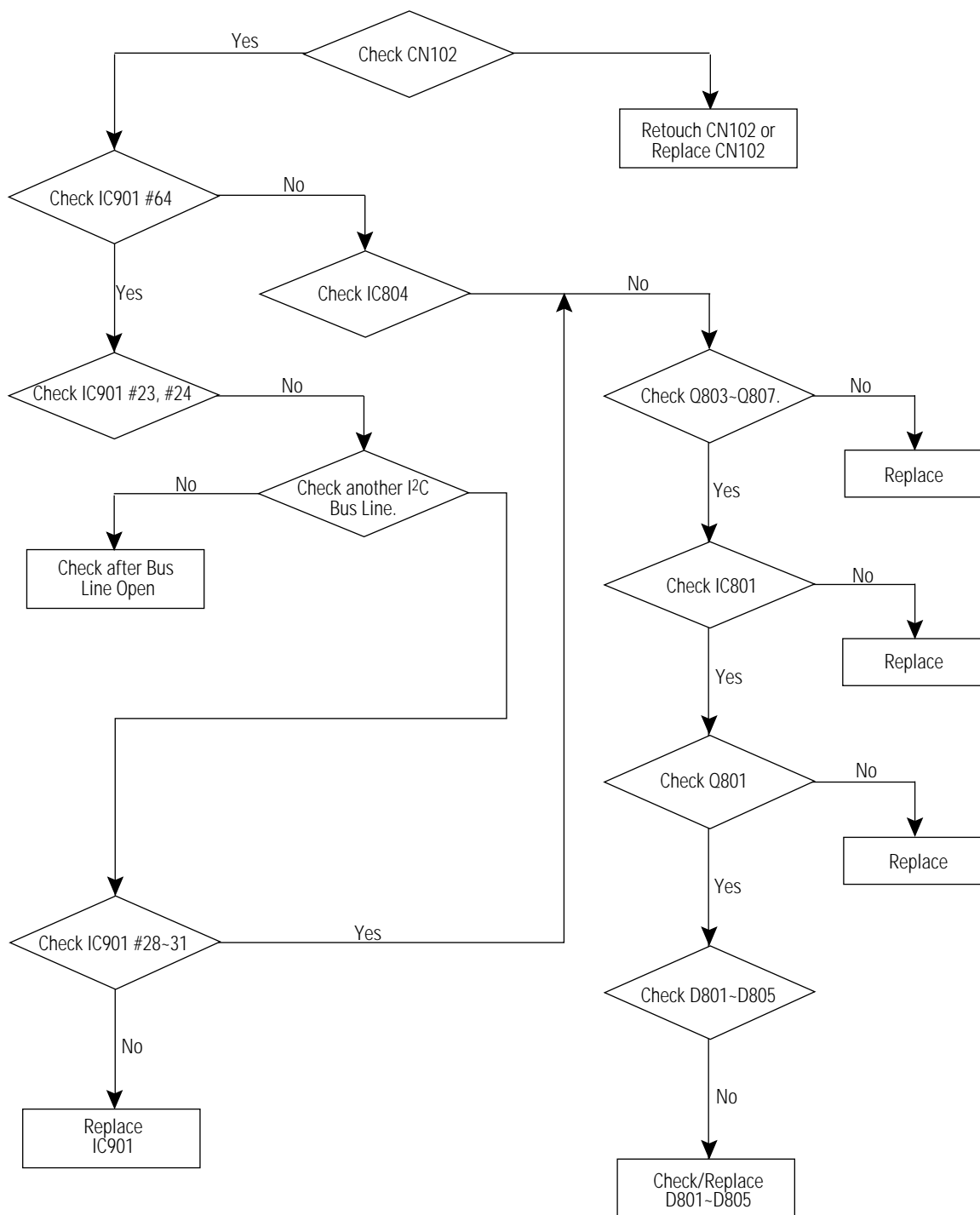

6-3 No RF Sound (Picture Ok)

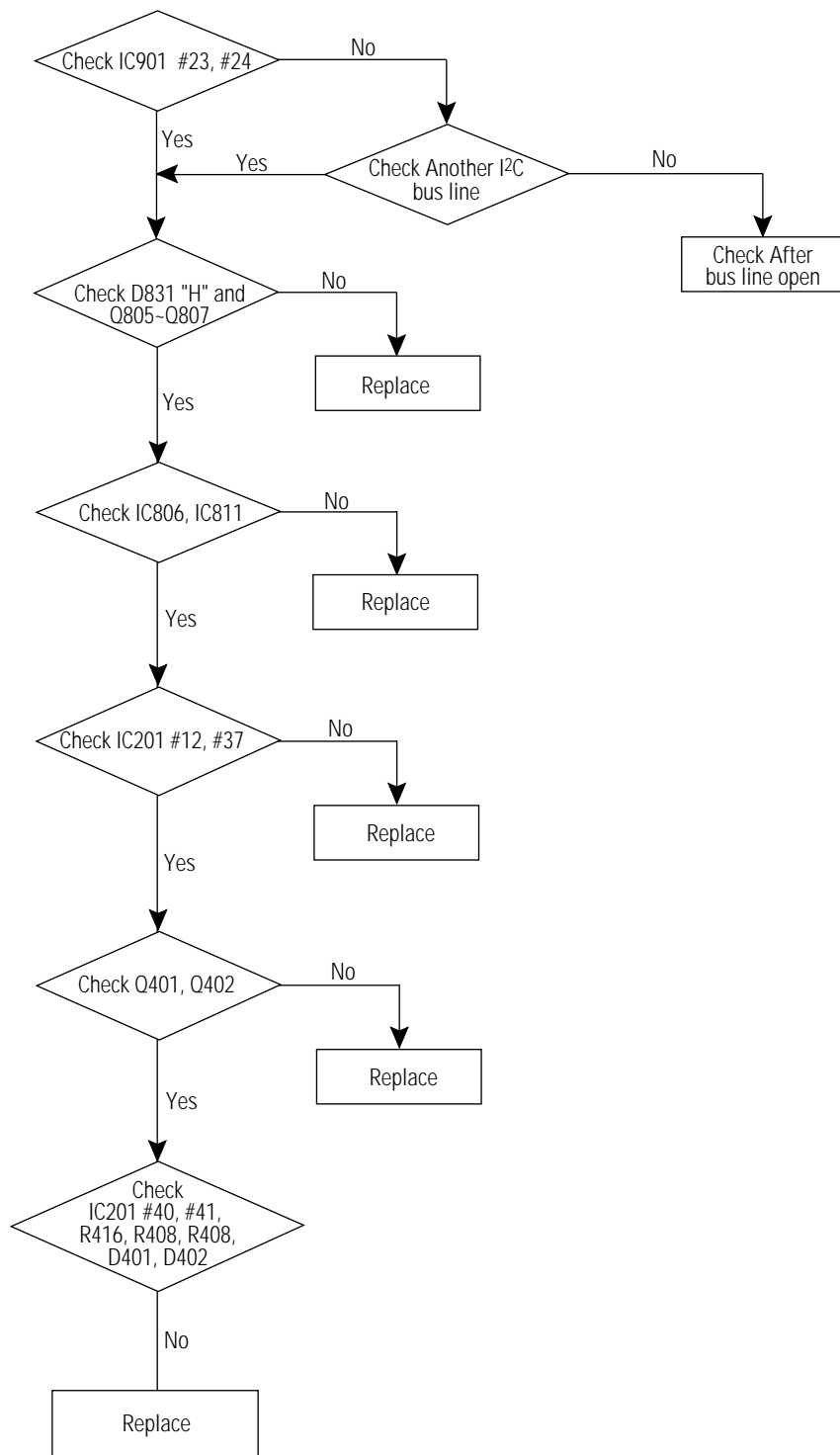

6-4 No Picture (Sound OK)

1. Check the Brightness, Contrast and Color adjustments
2. Check: AV Picture, Video Playback
3. See Video Block Diagram

6-5 No Sound (Picture OK)

1. Check the Volume adjustment level.
2. Check AV Video, Sound Playback
3. See Audio Block Diagram

6-6 RF Weak Signal (Playback, AV Mode OK)

1. Check Tuner (TU001) B+. Check: 12V (IC807)
33V (DZ803). Check 5V (IC802)
2. Pre AMP (HC001), B+. Check: 9V (IC803)
SPLITTER (SP001) B+. Check: 5V (IC803, ICU101)

6-7 Recording Defect

1. CN101 Check : Retouch
2. 2nd Tuner (TU002) B+. Check : 12V (IC807), 33V(DZ803)
5V (IC803, ICU101)
3. 2nd If : Check 12V (IC807), Video out, Audio out
4. Video Defect : IC701 Check
5. Audio Defect : IC704 Check
6. Standby Recording Defect, IC901 #5 Line: Check (D833, D838, IC808, IC807, IC806)
7. VPS (PDC) Recording Defect: Check IC901, #4

6-8 No Color

1. Check the Color Adjustment level
2. Check the Sandcastle Pulse Line : IC201 #41, IC202 #5, IC203 * #15
3. Check the R-Y, B-Y Line : IC201 #29~#32, IC202 #14, #16, #11, #12, IC203 #9, #10
4. Check IC203 : #15 (SECAM System)
5. Check crystal : X202 (4.43361MHz)

6-9 No Vertical SCAN

1. Check R410, D404
2. Check IC301, #7
3. Check IC201 #46, #47 Line
4. Check DY Connector

6-10 Horizontal Size

1. Check DZ805 & IC801
2. Check Q803
3. Check C402 & C403

6-11 On-Screen Display Missing

1. Check IC901 #2
(D921, Q901, DZ901)
2. Check IC901 #1 (R949, D919)

6-12 No Teletext

1. Check Q203 (IC203* #16)
2. Check the 1st 5V-Line (R842, D817, IC802)
3. Check ICT01 #1 (Vcc(5V) : Teletext Board)
4. Check ICT01 #8 (CVBS : Teletext Board)
5. Check IC201 #26 (TTX F/B)

6-13 Play Mode Inoperative

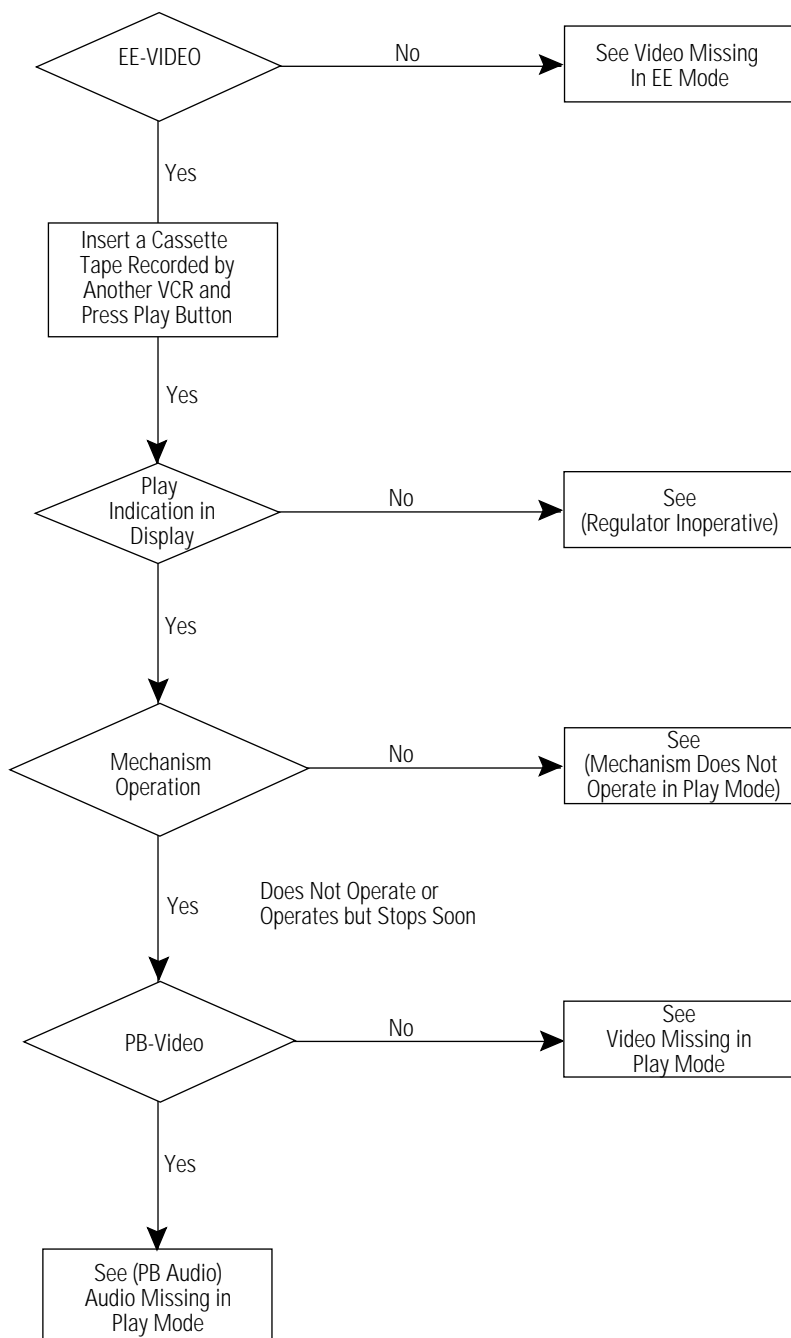

6-14 Mechanism Does Not Operate In Play Mode

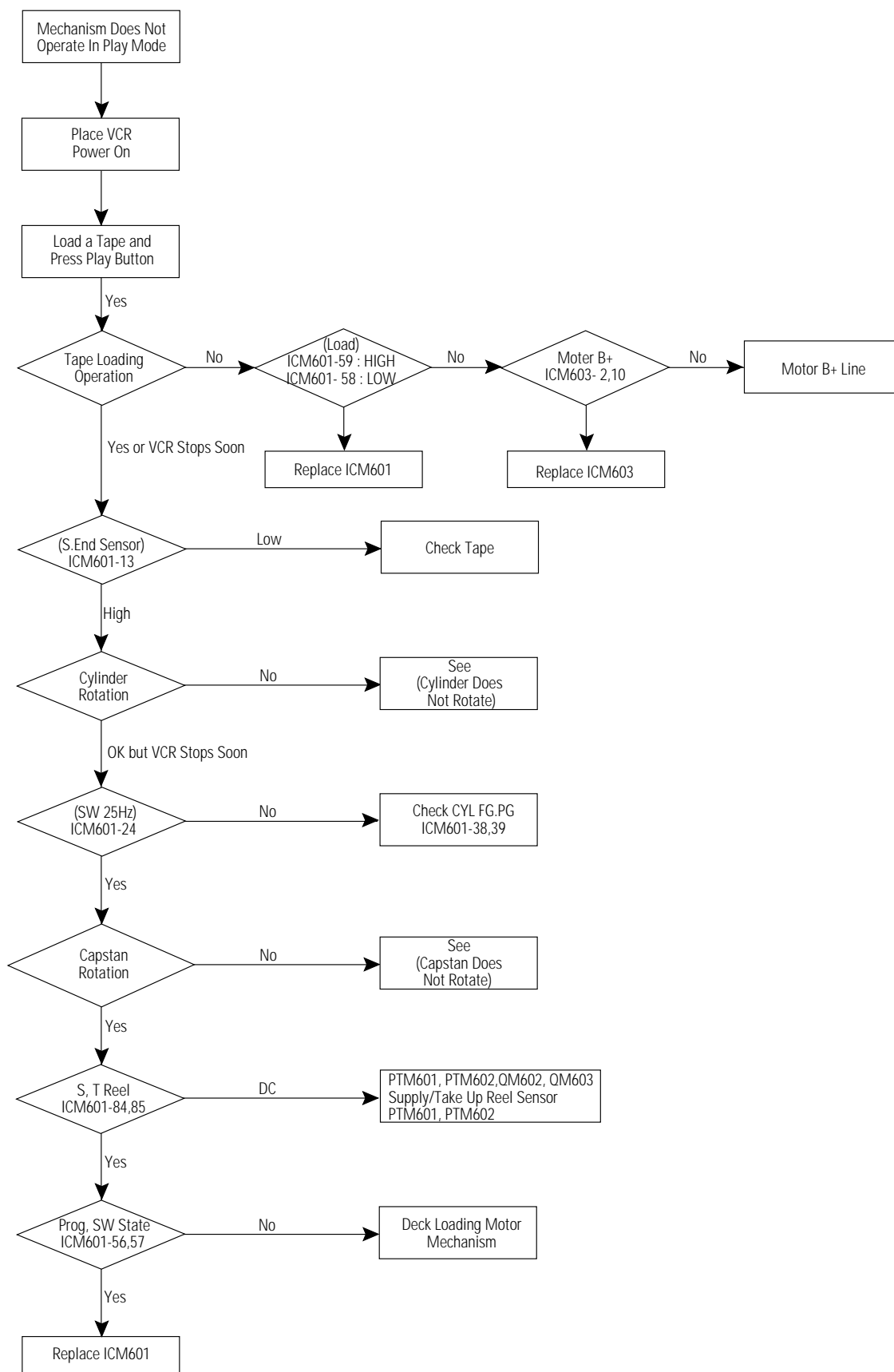

6-15 Record Mode Inoperative

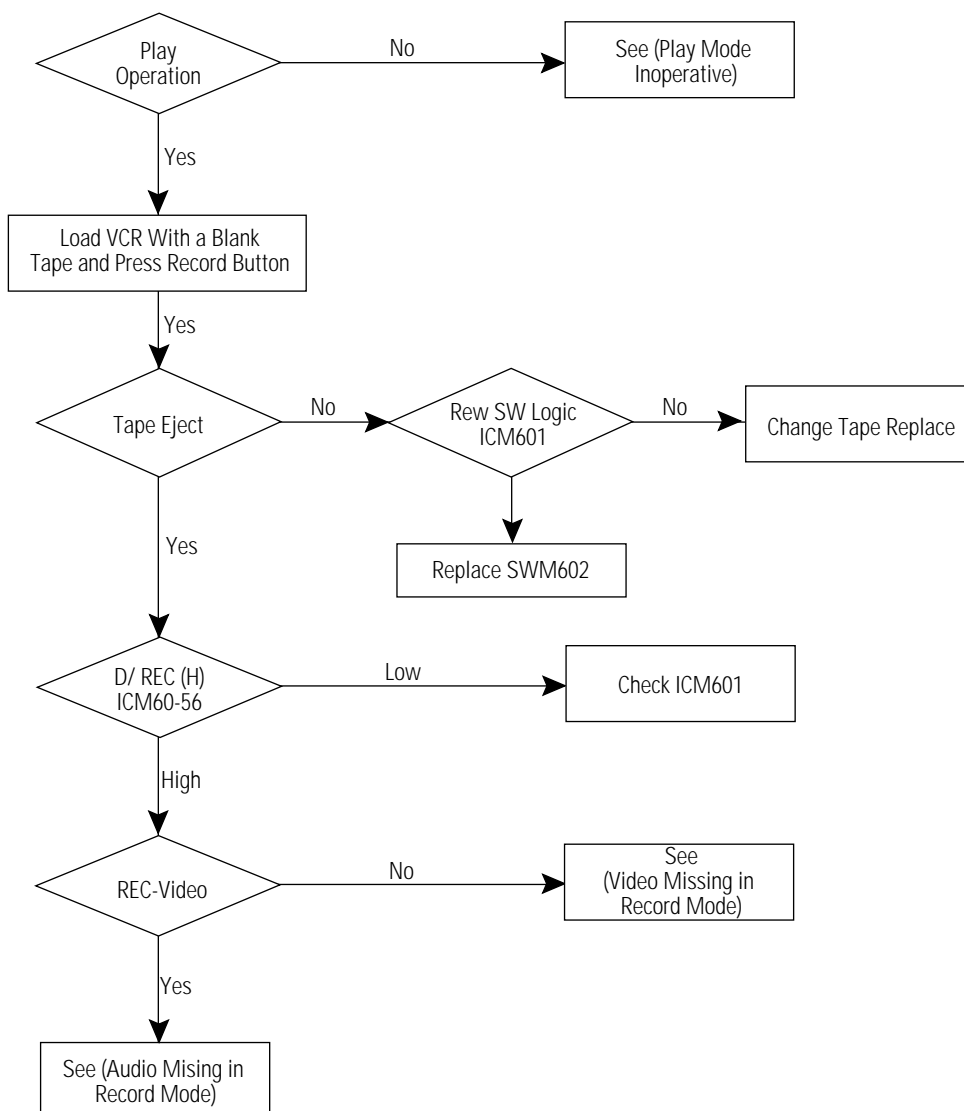

6-16 Fast Forward Mode Inoperative

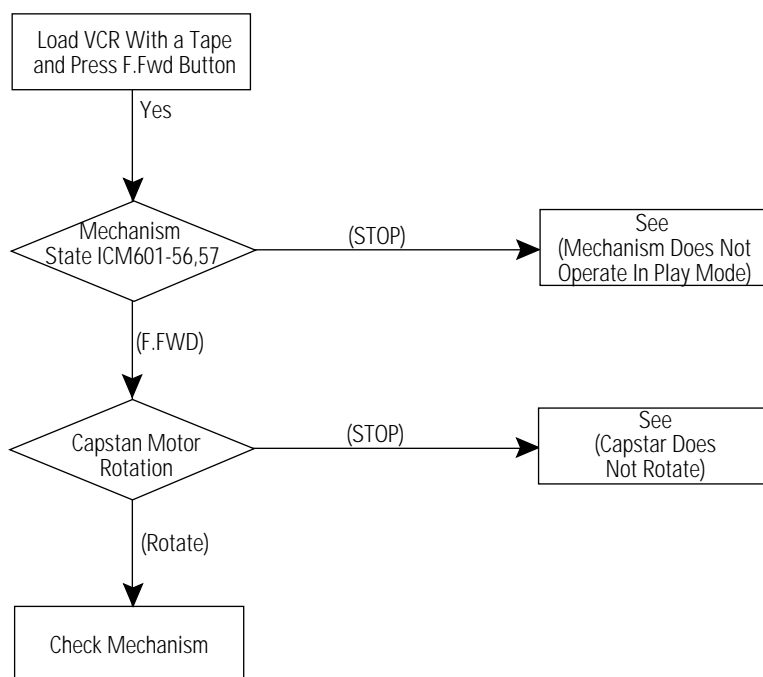

6-17 Rewind Mode Inoperative

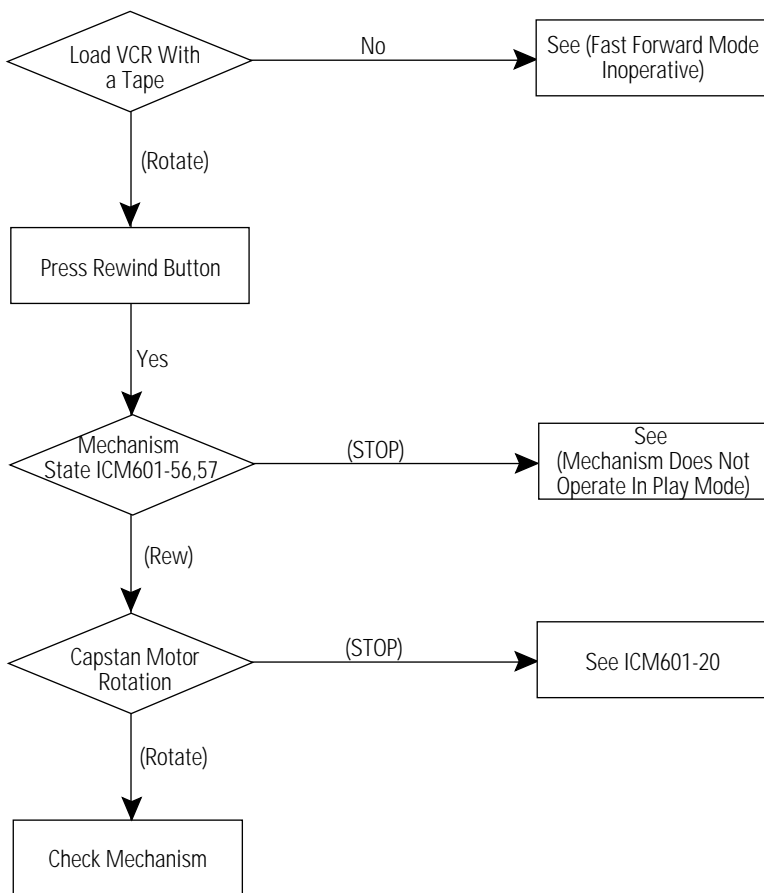

6-18 Rev Search Mode Inoperative

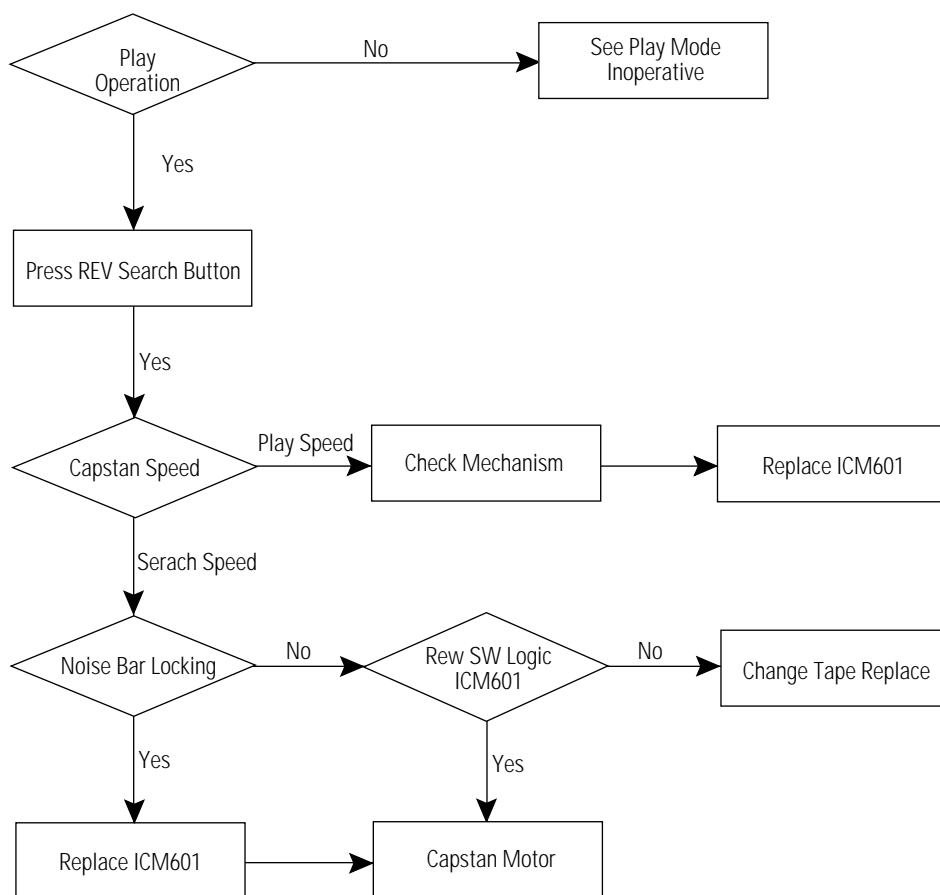

6-19 Cassette Loading Mechanism Does Not Operate

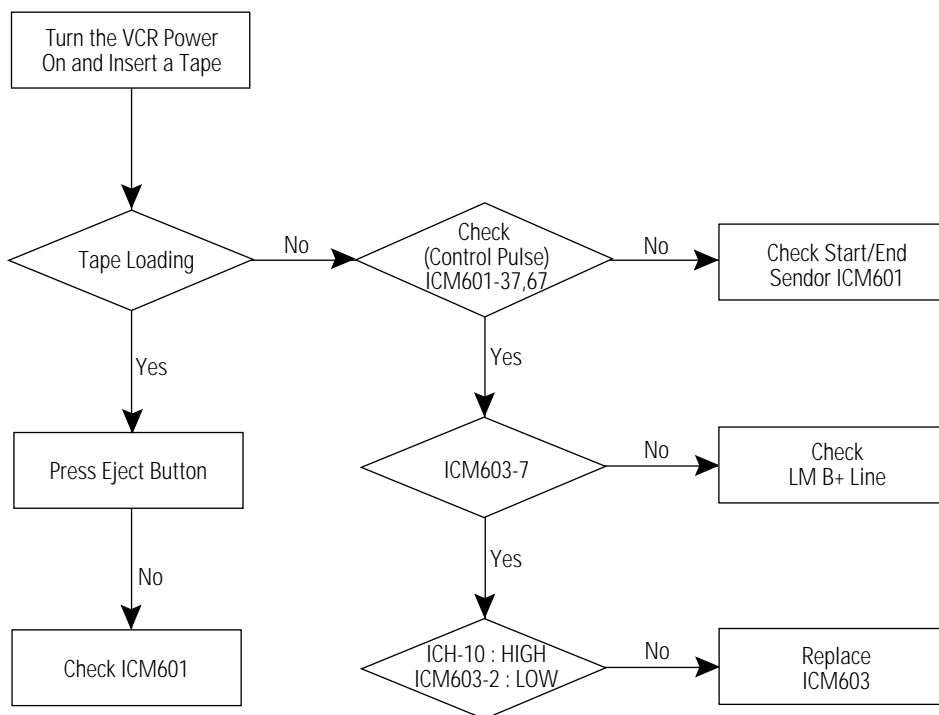

6-20 No Servo Lock

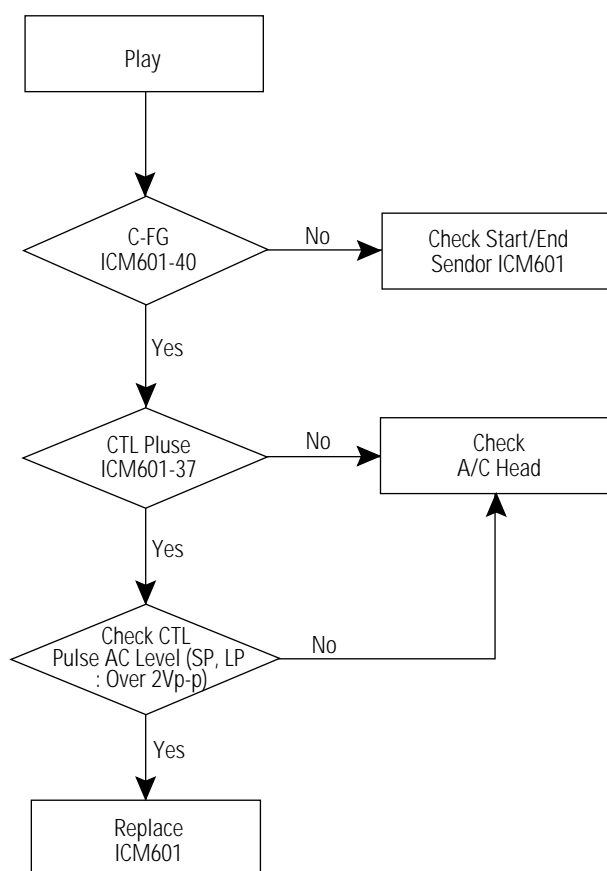

6-21 Capstan Does Not Rotate

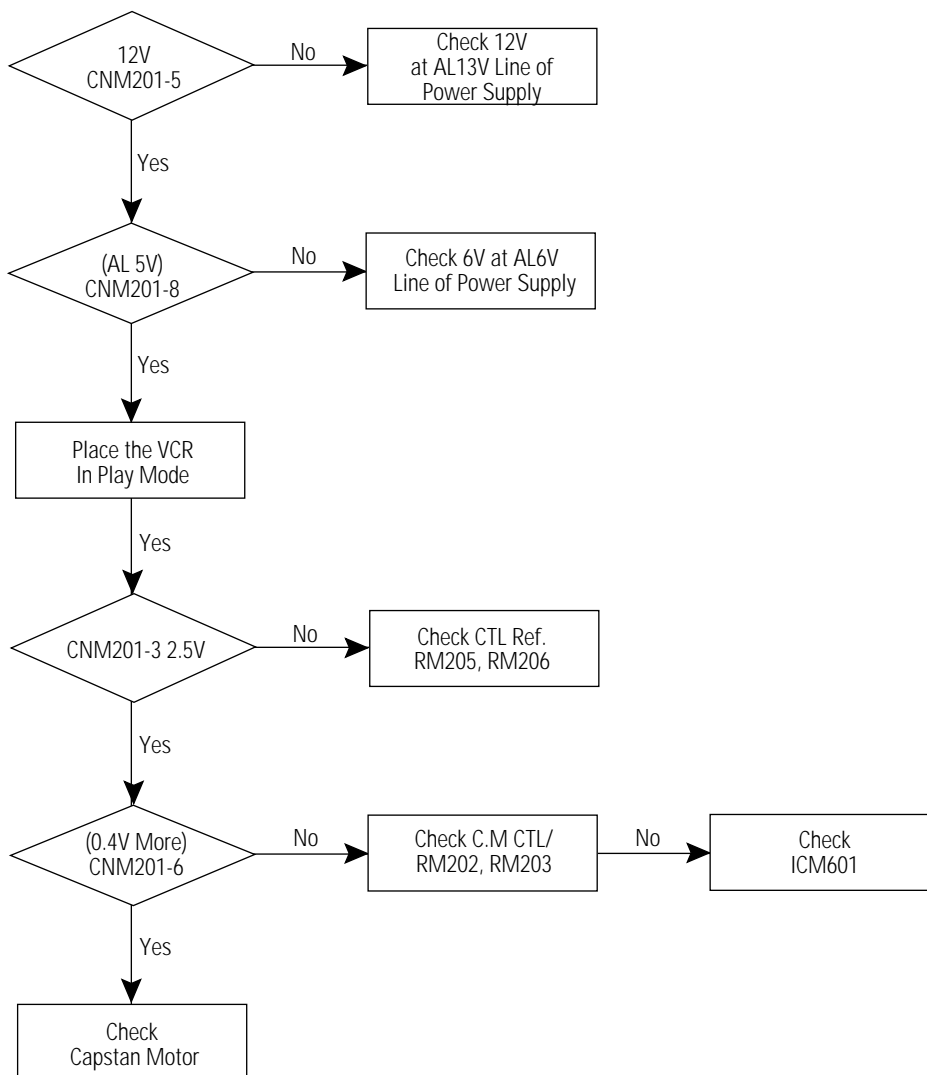

6-22 Drum Does Not Rotate

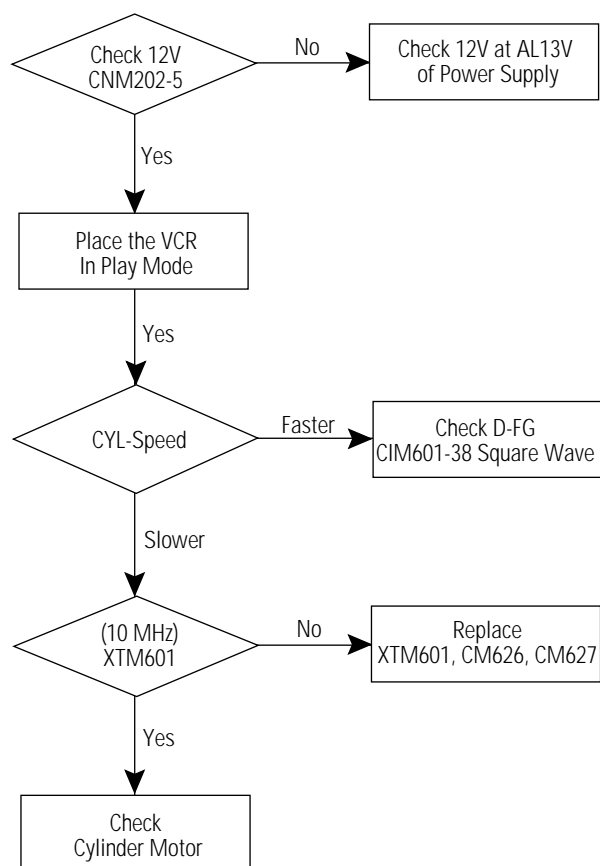

6-23 Video Missing In Play Mode

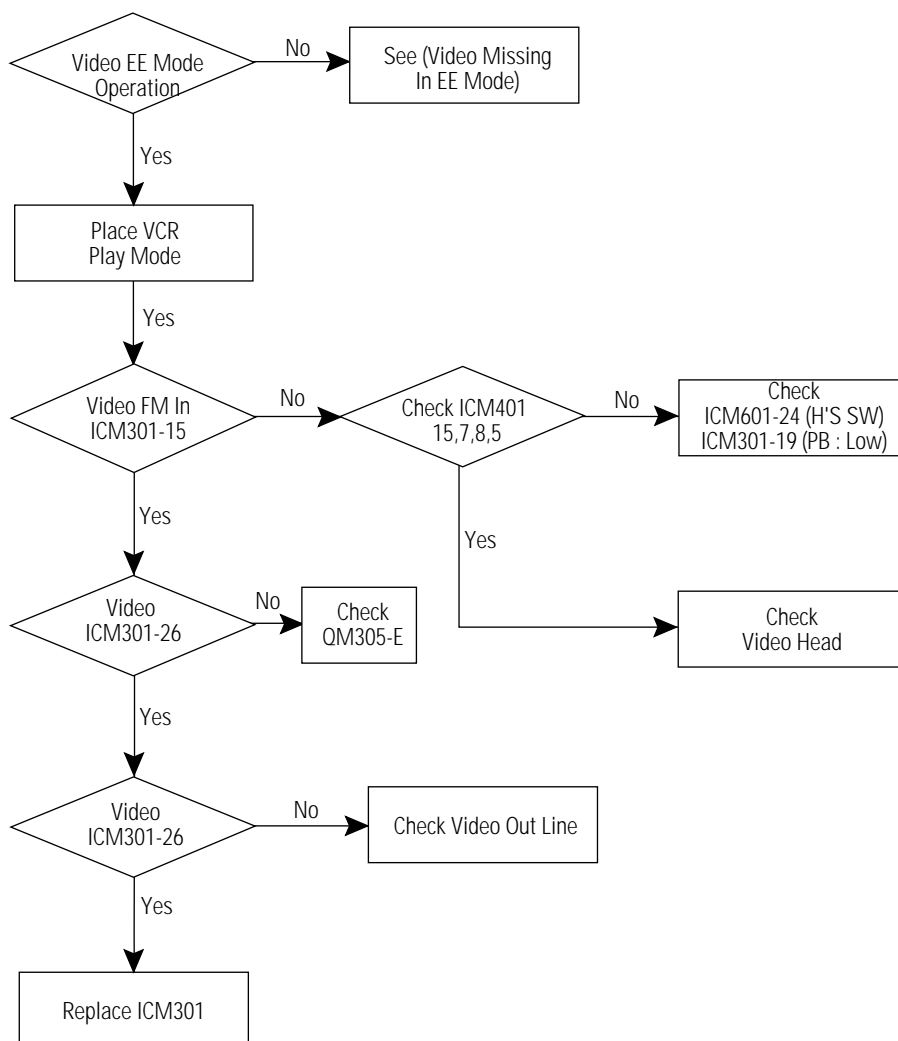

6-24 Video Missing In Record Mode

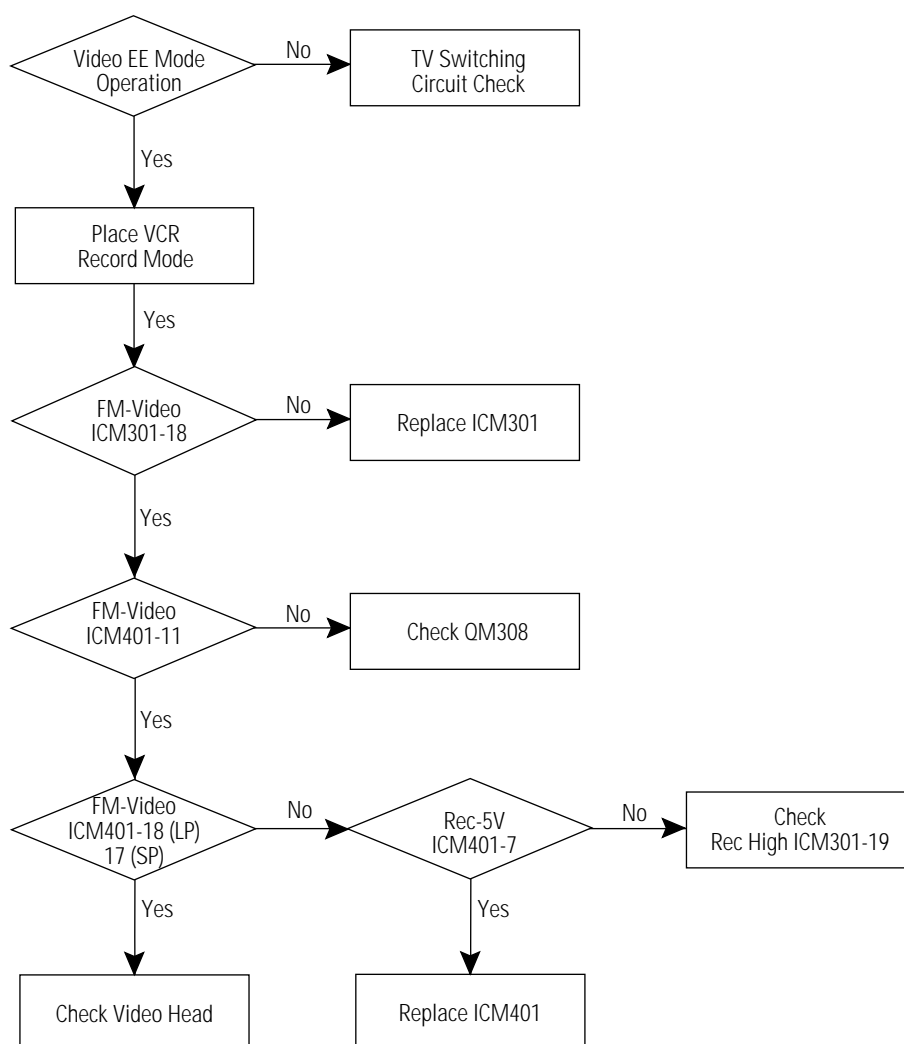

6-25 Color Missing In Play Mode

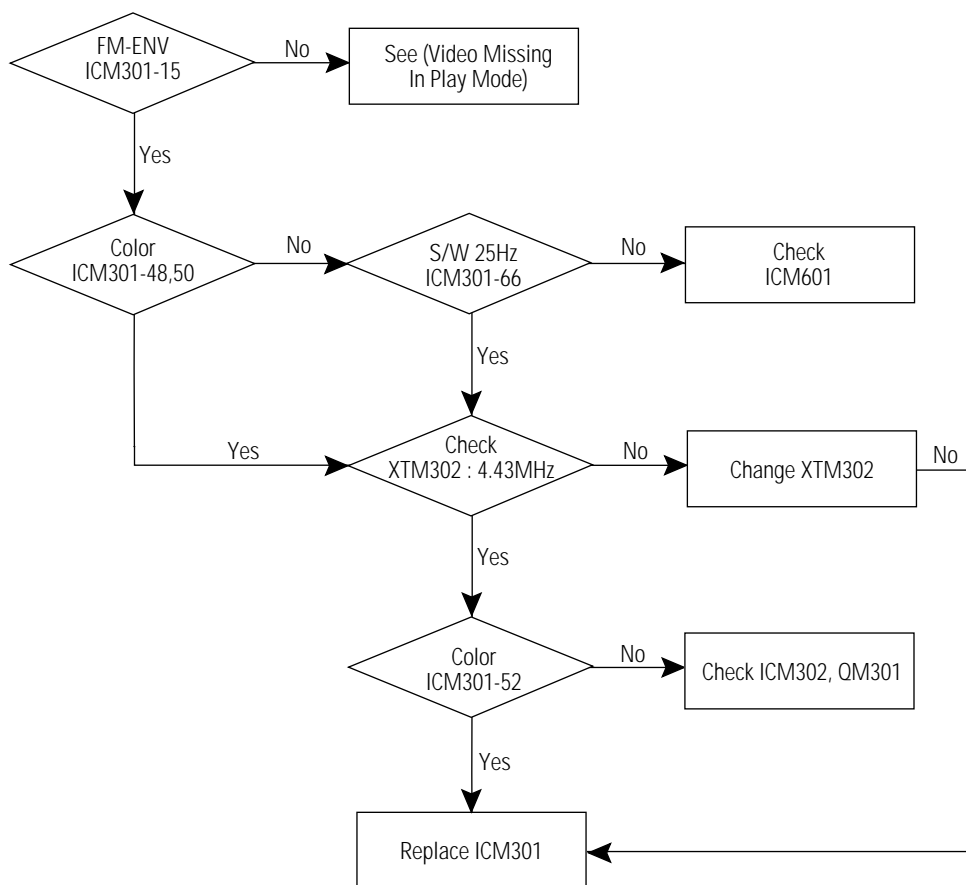

6-26 Color Missing In Record Mode

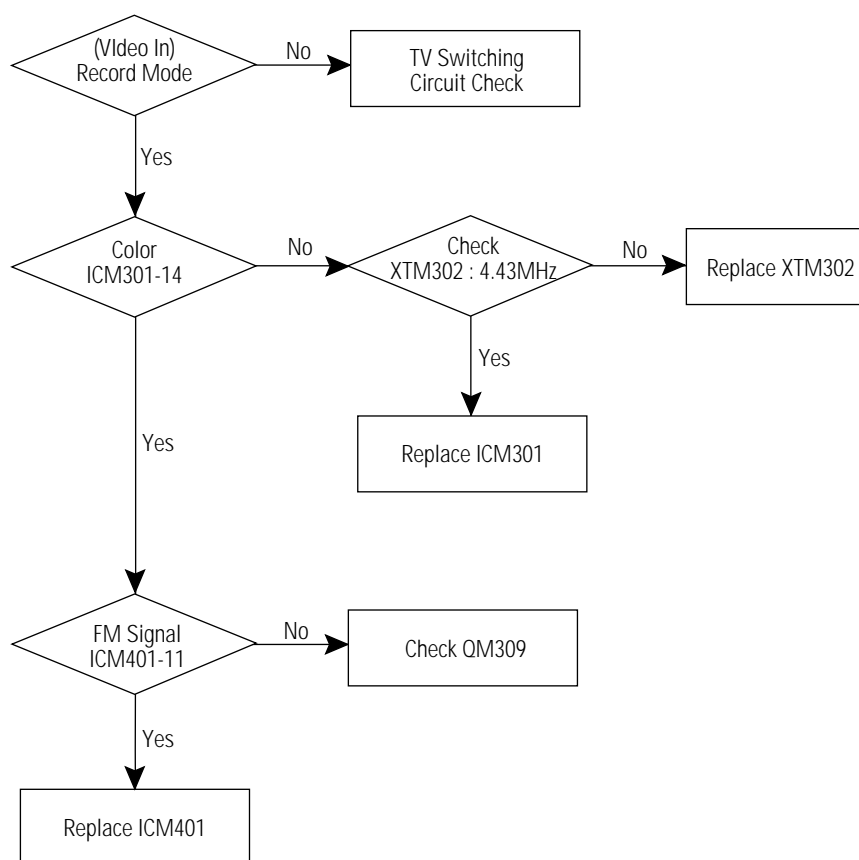

6-27 Audio Signal Missing in Play Mode

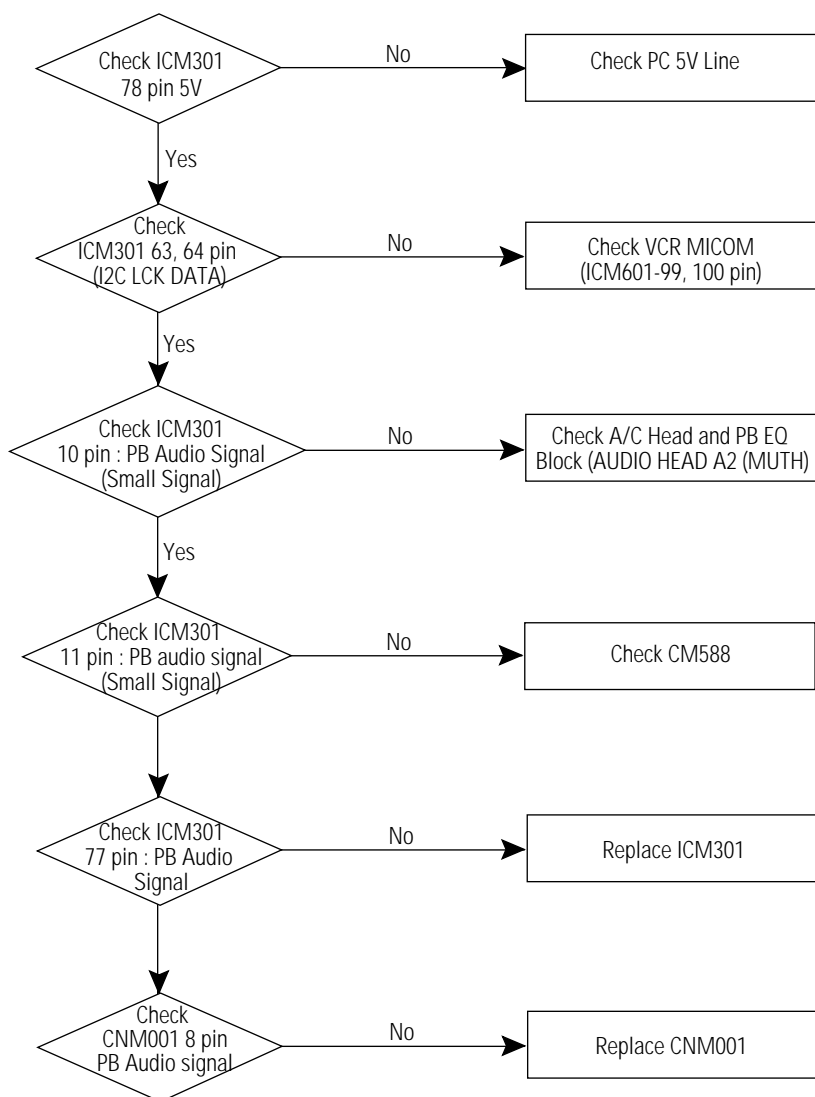

6-28 Audio Signal Missing After Recording

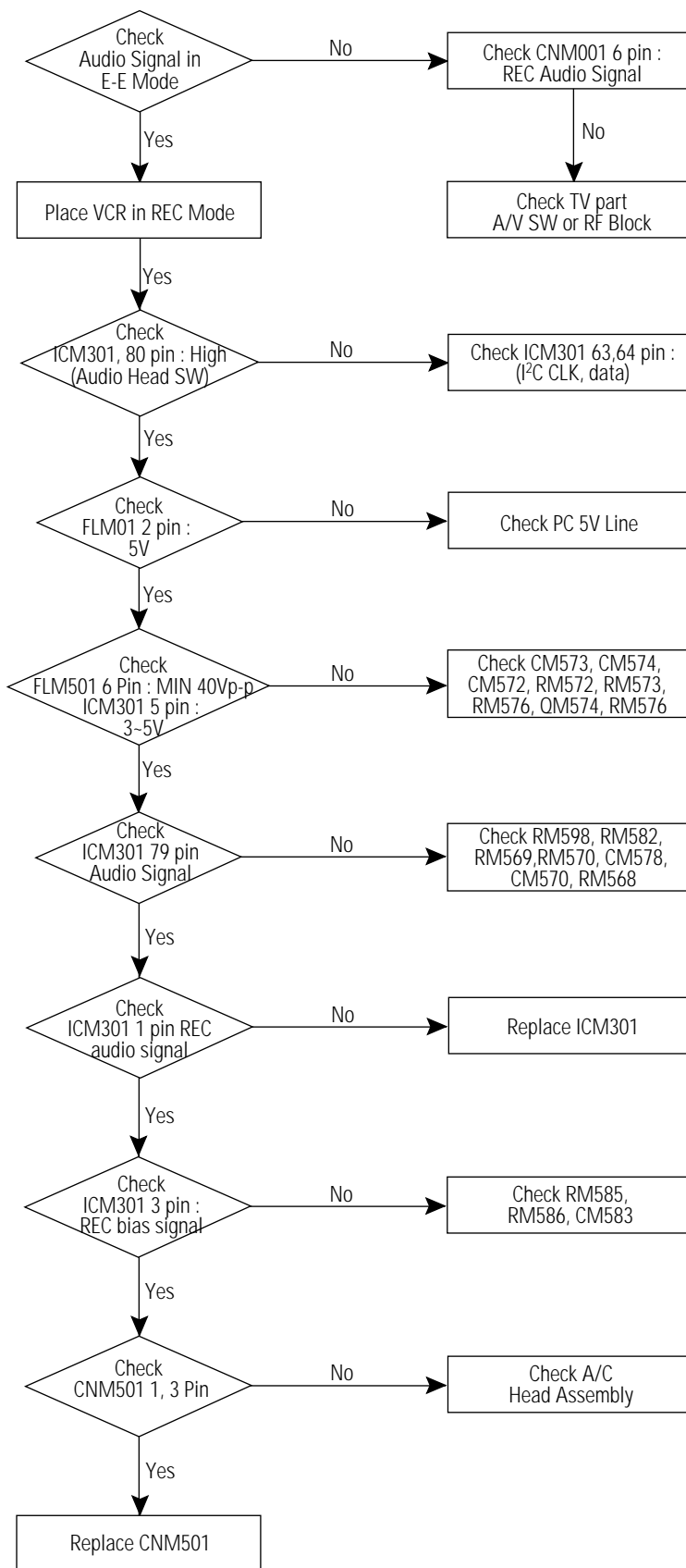

7. Exploded View & Parts List

7-1 TB331VDZ1S/XSA

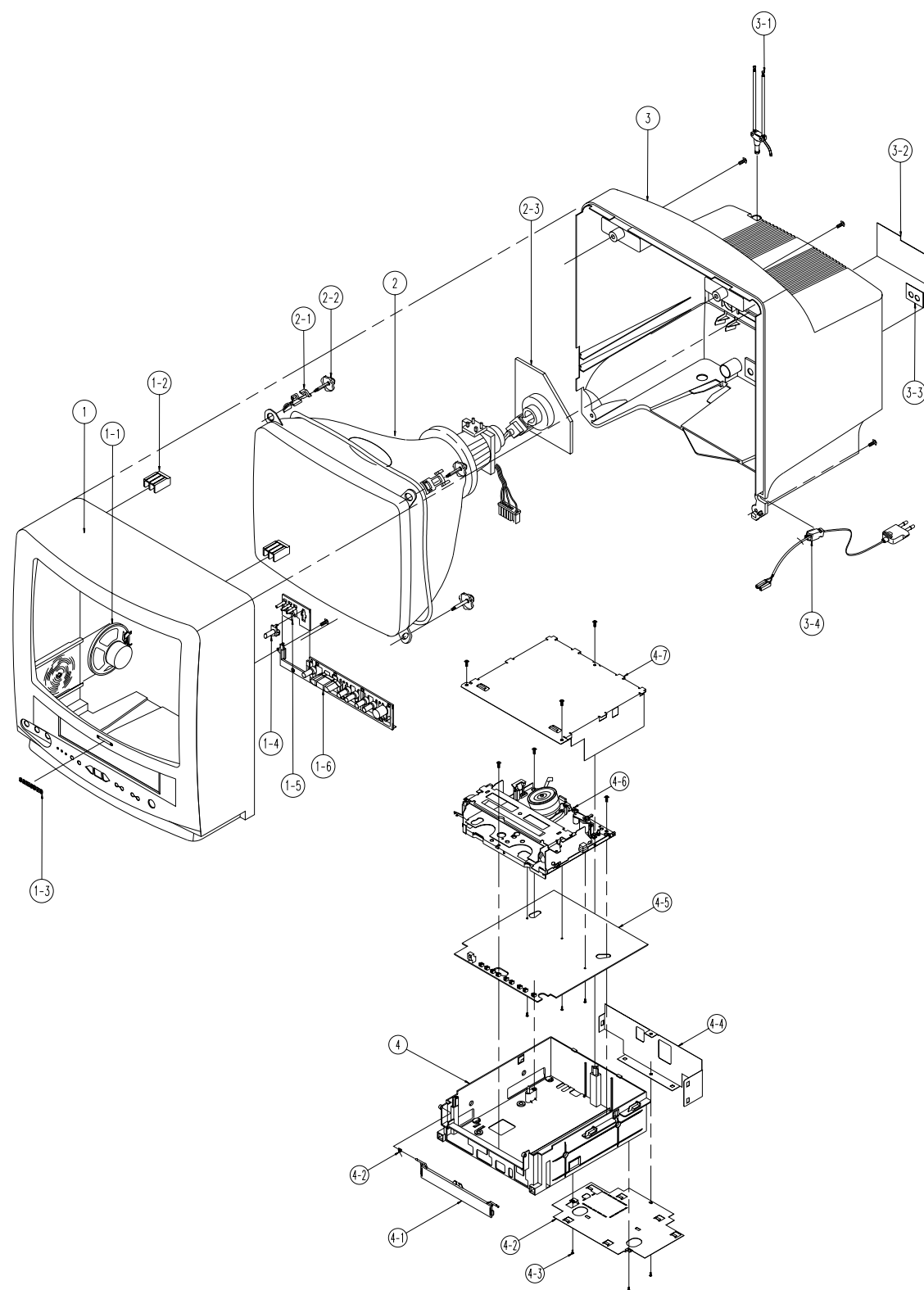

No	Code No	Description	Specification	Q'ty	Remark
1	AA90-50002K	ASSY-CABINET,FRONT	SESA EGN V0 MAST,T3350 SEAU	1	
	AA64-30093N	CABINET-FRONT	-,T3350,BK708P SEAU,HIPS,V0,BL	1	
1-1	3001-001015	SPEAKER	2.5W,16ohm,88dB,150Hz	1	
1-2	AA61-40015A	BOSS-CABINET	-,HIPS,HB,NTR,-,-	2	
1-3	AA64-70009D	BADGE-BRAND	AL,SS R2000 22,GOLD,L40,-,-,-	1	
1-4	AA64-40160A	INDICATOR-LED	-,T3350,-,PC,-,-,-	1	
1-5	AA64-40027A	WINDOW-REMOCON	-,T3350,1:20,PC,-,VIOLET,-	1	
1-6	AA64-10366B	KNOB-CONTROL	-,T3350,EG SESA,ABS,HB,BLK	1	
2	AA03-10002N	CRT-COLOR	-,A34KQV42X,-300MG,14,90DEG,5	1	
2-1	AA65-30016A	CLAMP-D,COIL	NYLON-66,V0,NTR,DADH-360 14,-	2	
2-2	AA60-10050R	SCREW-ASSY	WC,HH,+M5,L31.5,SWRCH18A,ZPC(4	
2-3	AA95-20008U	ASSY-PCB,CRT	-,SCV11D,14,NONE-EC,-	1	
3	AA64-30650A	CABINET-BACK	-,T3350,-,HIPS,V0,BLK,-,-	1	
3-1	AA42-10001V	ANT-ROD	-,3S,620mm,BRN,UL/CSA	1	
3-2	AA64-60062J	INLAY-BACK	T3350,RCA 1TUN,PS,T0.5,BLK,-,-	1	
3-3		DELETE ITEM			
3-4	AA61-20050A	HOLDER-CORD	-,PP,V0,BLK,DO	1	
4	AA90-40001F	ASSY-FRAME	V0,C2-DECK PAL	1	
4-1	AA64-50049S	DOOR-HOUSING	-,T3350,BK-708P J/DRV G/D,ABS,	1	
4-2	AA63-30110A	COVER-FRAME,BOT	-,SV-M30.M80,-,SECC,-,NTR,T0.5	1	
4-3	6002-000507	SCREW-TAPPING	RH,+2,M3,L12,ZPC(YEL),SWRCH18	4	
4-4	AA63-30111A	COVER-FRAME,BACK	-,SV-M30.M80,-,SPT,-,NTR,T0.5	1	
4-5	AA94-80003M	ASSY-M/DECK	M-320XK/SEG-S,2HD,PAL/MESECAM,	1	
4-6	AA91-40099A	ASSY-DECK	-,2HD PAL/MESEC/SEC,DX-7A	1	
4-7	AA63-30109A	COVER-FRAME,TOP	-,SV-M30.M80,-,SECC,-,NTR,T0.5	1	

7-2 TB531VCT1X/XSA

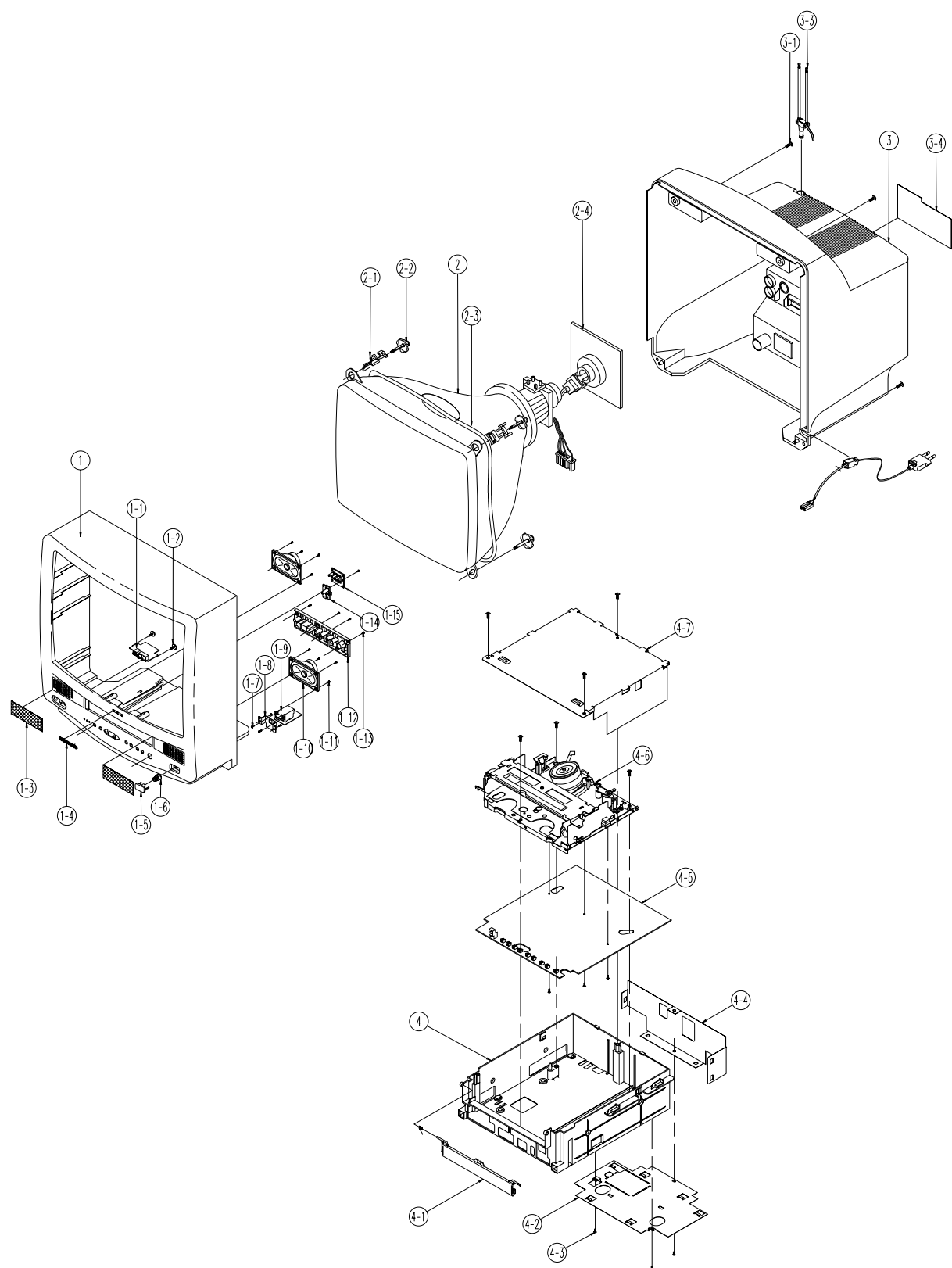

No	Code No	Description	Specification	Q'ty	Remark
1	AA91-10261X	ASSY-CABINET,FRONT	-,T5350,BK-708P SEAU MAST,V0,B	1	
	AA64-30863P	CABINET-FRONT	-,T5350,BK-708P SEAU,HIPS,V0,B	1	
1-1	AA95-40010F	ASSY-PCB,A/V	-,TVP5350FST,SCV11D,-,MONO,FRA	1	
1-2	AA60-10002A	SCREW-TAPPING	RH,+,M4,L12,ZPC(YEL),-,OD142		
1-3		DELETE ITEM			
1-4	AA64-70010D	BADGE-BRAND	AL,SS R2000 25,GOLD,L50,-,-,-	1	
1-5	AA64-10580J	KNOB-POWER,M	-,T3350,BK-708P MASTER G/D,ABS	1	
1-6	AA61-60005E	SPRING-CS	-,SUS304,0.6,OD12,H12.5,N5,-,-	1	
1-7	6001-000677	SCREW-MACHINE	RH,+,M3,L6,ZPC(YEL),SM20C,-	2	
1-8	AA61-10320A	BRACKET-MASTER	-,T3350,SECC,T1.0,-,-,-	1	
1-9	3403-001020	SWITCH-PUSH	250V,5A,DPST,OFF-ON-OFF	1	
1-10	3001-001008	SPEAKER	5W,16ohm,90dB,180Hz	2	
1-11	6002-000506	SCREW-TAPPING	RH,+,2,M3,L12,ZPC(BLK),SWRCH18	8	
1-12	AA64-10013C	KNOB-FAMILY	-,T5050,BK-708P G/D,ABS,HB,BLK	1	
1-13	6002-000406	SCREW-TAPPING	RH,+,2,M3,L10,ZPC(YEL),SWCH18	4	
1-14	AA64-40043A	WINDOW-REMOCON	-,T5050,-,PC,V0,VIOLET,-	1	
1-15	AA64-40165A	INDICATOR-LED	-,T5050,-,PC,-,-,-	1	
2	AA03-10004H	CRT-COLOR	-,A51KQJ63X(U),-300MG,21,90DE	1	
2-1	AA65-30019A	CLAMP-D,COIL	NYLON-66,V0,NTR,DADH-460 20,-	4	
2-2	AA60-10050R	SCREW-ASSY	WC,HH,+,M5,L31.5,SWRCH18A,ZPC(4	
2-3	AA27-20001Z	COIL-DEGAUSSING	-,21,14.5ohm,35T,L2500,E	1	
2-4	AA95-20010V	ASSY-PCB,CRT	-,SCV11F,21,NON-EC,-	1	
3	AA64-30865B	CABINET-BACK	-,T5350,-,HIPS,V0,BLK,-,-	1	
3-1	6002-000514	SCREW-TAPPING	RH,+,2,M4,L15,ZPC(BLK),SWRCH18	4	
3-3	AA42-10001V	ANT-ROD	-,3S,620mm,BRN,UL/CSA	1	
3-4	AA64-60062F	INLAY-BACK	T3350,RCA 2TUN,PS,T0.5,BLK,-,-	1	
4	AA90-40001F	ASSY-FRAME	V0,C2-DECK PAL	1	
4-1	AA64-50245P	DOOR-HOUSING	-,TVCR-516,BK-708P J/DRV GOLD,	1	
4-2	AA63-30110A	COVER-FRAME,BOT	-,SV-M30.M80,-,SECC,-,NTR,T0.5	1	
4-3	6002-000507	SCREW-TAPPING	RH,+,2,M3,L12,ZPC(YEL),SWRCH18	3	
4-4	AA63-30111A	COVER-FRAME,BACK	-,SV-M30.M80,-,SPT,-,NTR,T0.5	1	
4-5	AA96-80002S	ASSY-PCB,M/DECK	M-320XK/SEG-S,2HD,PAL/MESECAM,	1	
4-6	AA91-40105A	ASSY-DECK	-,2HD PAL/MESECAM/NTPB,DX-7A	1	
4-7	AA63-30109A	COVER-FRAME,TOP	-,SV-M30.M80,-,SECC,-,NTR,T0.5	1	

7-3 Mechanical Parts (Top Side)

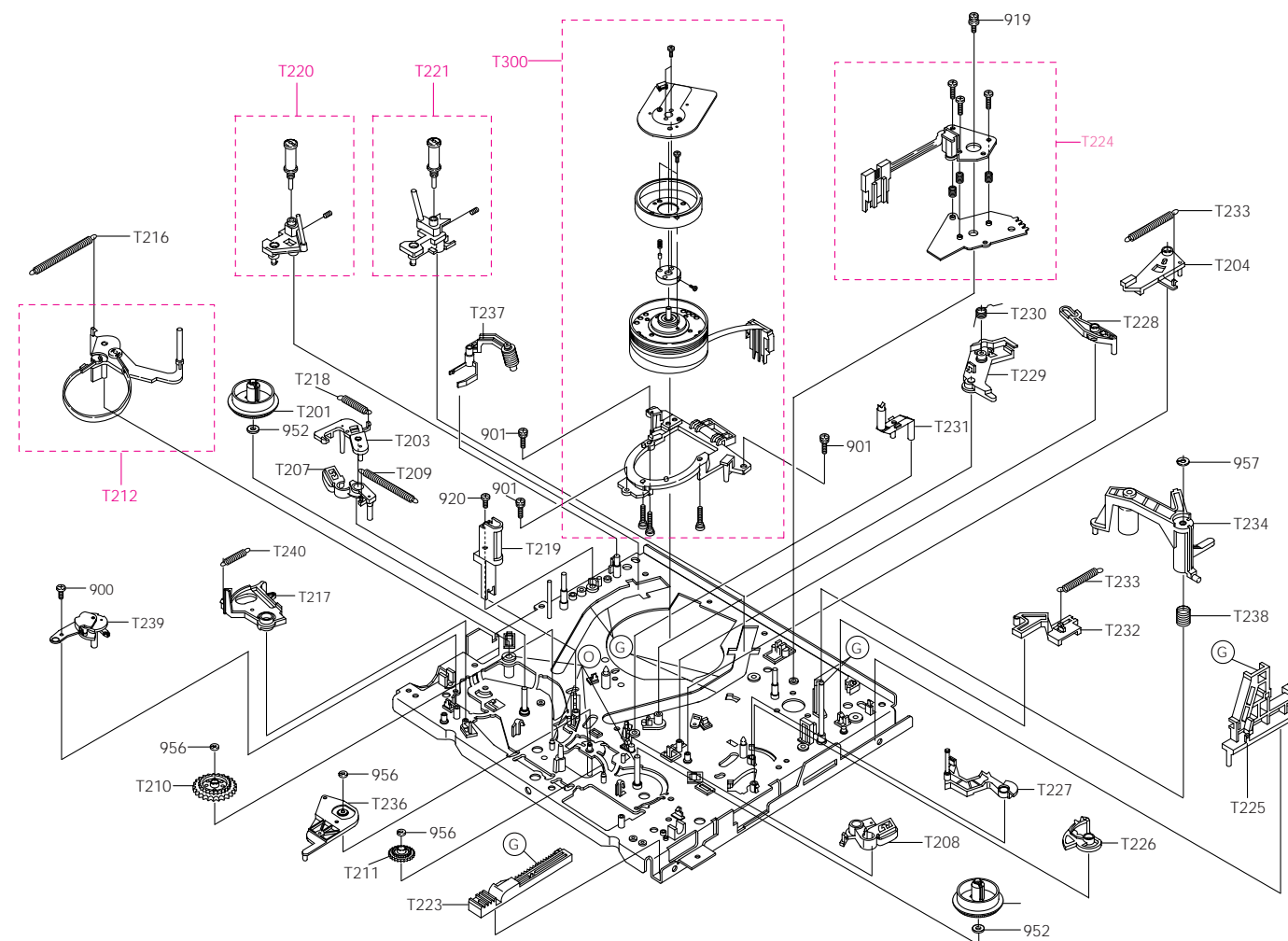

Loc. No	Part No	Description and Specification	Remark
901	AC60-10012A	SCREW-MACHINE;BH,+,M3,L8,-,FE,-,-,-	
919	AC60-10004A	SCREW-MACHINE;BH,+,M3,L8,ZPC,SWRCH18A,-,	
920	AC60-10007A	SCREW-TAPPING;BH,+,M2.6,L12,-,SWRCH18A,-	
952	AC60-30018A	WASHER-PLAIN;PLAIN,M3.2,D6,T0.5,POLYSLID	
956	AC60-30007A	WASHER-SLIT;PLAIN,ID2.5,OD7,T0.5,SPC1,-,	
957	AC60-30008A	WASHER-SLIT;-ID3.5,OD9,T0.5,SPC1,-,-	
T201	AC66-10023A	REEL-DISK L ASSY;POM,-,PACKAGE,X-5,-	
T202	AC66-10022A	REEL-DISK R (ASSY);POM,-,PACKAGE,X-5,-	
T203	AC66-30474A	BRAKE-SUB L;-PBT,-,-,-,X-5/IS	
T204	AC66-30148A	BRAKE SUB R;-,-,-,-,X5,-	
T207	AC66-30475A	BRAKE-MAIN L ASS'Y;-POM+PELT,-,-,-,X-5/	
T208	AC66-30476A	BRAKE-MAIN R ASS'Y;-POM+PELT,-,-,-,X-5/	
T209	AC61-60112A	SPRING- BRAKE MAIN;ES,SUS304WPB,PI0.35,I	
T210	AC66-20073A	GEAR RELAY S-ASSY;-,-,-,-,-,X5,-	
T211	AC66-20037A	GEAR- RELAY T;PEBAX7033,X-5,Z39,GEAR-SPU	
T212	AC66-30073A	ARM-TENSION ASSY;-DX5-R,-,-,-,-	
T216	AC61-60119A	SPRING TENSION;ES,SWPB,PI0.4,D3,L33(OD3.	
T217	AC66-30470A	LEVER-REC S/W;-PBT #3300,T4.0,L32,-,(X-	
T218	AC61-62017A	SPRING-SUB BRAKE L;ES,SUS304,PI0.23,D3.5	
T219	AC33-10003P	HEAD- MAGNET F/E;MH131S,-,-,-,L51.05XW7.	
T220	AC66-82050A	SLIDER-G/R ASSY(S);-,-,-,-,-,X-5	
T221	AC66-82054A	SLIDER-G/R ASSY(T);-,-,-,-,-,X-5	
T223	AC66-20065A	RACK-HOUSING;L74.29,POM M90-44,BLK,M1,3.	
T224	AC33-10216K	HEAD-ACE ALL ASSY;-,-,-,-,-,X-7A	
T225	AC66-80005A	SLIDER-PINCH;POM(M90-44),T10.5,L54.35,NA	
T226	AC66-30014A	LEVER-REVIEW;ZYTEL(70G-43L),T5,-,PCD25.6	
T227	AC66-30099A	ARM-REVIEW ASSY;-,-,-,-,-,DX5-R,-	
T228	AC66-30013A	LEVER- CAM;PBT 6300T,-,L45,W9,X-5,-	
T229	AC66-30003A	LEVER-PINCH COMP;PBT 3300,T7.5,L45.25,-,	
T230	AC61-60116A	SPRING- PINCH COMP;TS,SWPB,PI1.0,D6,L38(
T231	AC67-32001A	PRISM-LED;PMMA,D5,IF-850,-,-,-,-	
T232	AC66-82049A	SLIDER-PUSH;LUPOX 2150,T2,-,NTR,-	
T233	AC61-62016A	SPRING-SLIDE PUSH;ES,SUS304WPB,PI0.55,D3	
T234	AC59-90402A	UNIT-PINCH ROLLER;X-7A,RESIN BEARING	
T236	AC66-10010A	IDLER-ASSY;PACKAGE,-,X-5,-	
T238	AC61-60132A	SPRING ARM PINCH;CS,SUS304WPB,PI0.4,D7.1	
T240	AC61-60505A	SPRING-REC S/W;-ES,SUS304 WPB,PI0.29,PI	
T300	AC96-10475D	ASSY-CYLINDER;-CX8A-S2P (2HEAD)	
T300	AC96-10475E	ASSY-CYLINDER;-CX8A-S2P/DLC (2HEAD)	
T300	AC96-10480F	ASSY-CYLINDER;-CX8A-S2P(LP)	
T300	AC96-10475F	ASSY-CYLINDER;-CX8A-D4P	
T300	AC96-10475G	ASSY-CYLINDER;-CX8A-D4P/DLC	

7-4 Mechanical Parts (Bottom Side)

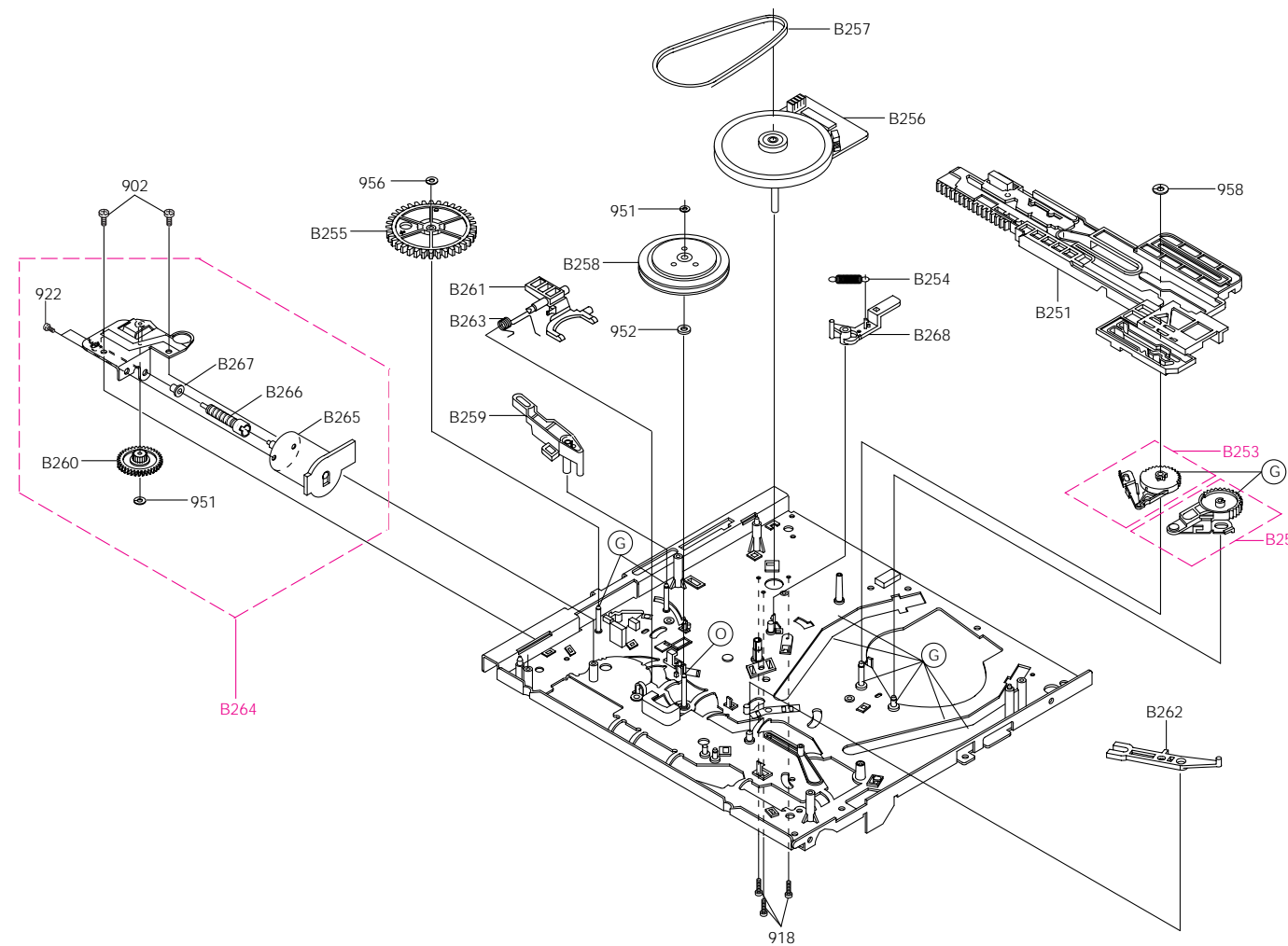

Loc. No	Part No	Description and Specification	Remark
902	AC60-10051A	SCREW-TAPPING;BH,-,-,M3,L8,FZY	
918	AC60-10041A	SCREW-TAPPING;BH,+,-,M2.6XL7.5,ZPC3	
922	AC60-10504A	SCREW-MACHINE;-;PH,+,-,M3,L3,FE,FZY,YEL	
951	AC60-30025A	WASHER-SLIT;-;ID2.5,OD5.0,T0.5,POLY SLID	
952	AC60-30018A	WASHER-PLAIN;PLAIN,M3.2,D6,T0.5,POLYSLID	
956	AC60-30007A	WASHER-SLIT;PLAIN,ID2.5,OD7,T0.5,SPC1,-	
958	AC60-30028A	WASHER-SLIT;-;D2.5,D9.0,T0.5,NUMIRROR,-	
B251	AC66-82043A	SLIDER-MAIN;TOPEX 4010S,-,-,-,-	
B252	AC66-20019A	GEAR-LOADING L ASSY;-,-,-,PACKAGE,-,X-5,	
B253	AC66-20069A	GEAR-LOADING R ASSY;-,-,-,-,X5,-	
B254	AC61-60115A	SPRING-BRAKE CAPSTAN;ES,SUS304WPB,PI0.4,	
B255	AC66-20004A	GEAR-MASTER;POM (M90-44),M 1,Z 60,SP,-,X	
B256	AC31-12006A	MOTOR-D/D CAPSTAN;DMVCMC07A,-,-	
B257	AC66-62008A	BELT-CAPSTAN;-;DLB-601,T2,8,L134.9,BLK,X	
B258	AC66-20066A	GEAR-CLUTCH ASSY;X-5,-,-,-,-,-	
B259	AC66-32185A	LEVER-SLIDER PINCH;PBT,T4,NAT,-,-,-	
B260	AC66-20016A	GEAR- WORM WHEEL;POM SW-01,M0.55/M1,Z57/	
B261	AC66-30011A	LEVER- SHIFT;PBT2002K,T10.9,L35,-,-,-	
B262	AC66-30012A	LEVER- IDELR CHANGE;PBT330,T33,L50,-,W6.	
B263	AC61-60111A	SPRING-LEVER SHIFT;TS,SWPB,PI0.7,D5.5,L1	
B264	AC59-90001A	UNIT-LOADING ASSY;X-5,-,-	
B265	AC31-12015A	MOTOR-LOADING ASSY;POM+RF370C X-5	
B266	AC66-20039A	GEAR- WORM LO;PBT 2002K,-,-,-,D4.5,3,-	
B267	AC61-20224A	HOLDER SHAFT;POM M90-44,T1.25,NTR,PI5XH5	
B268	AC66-30149A	BRAKE CAPSTAN;-,-,-,-,X5,-	

7-5 Housing Assembly

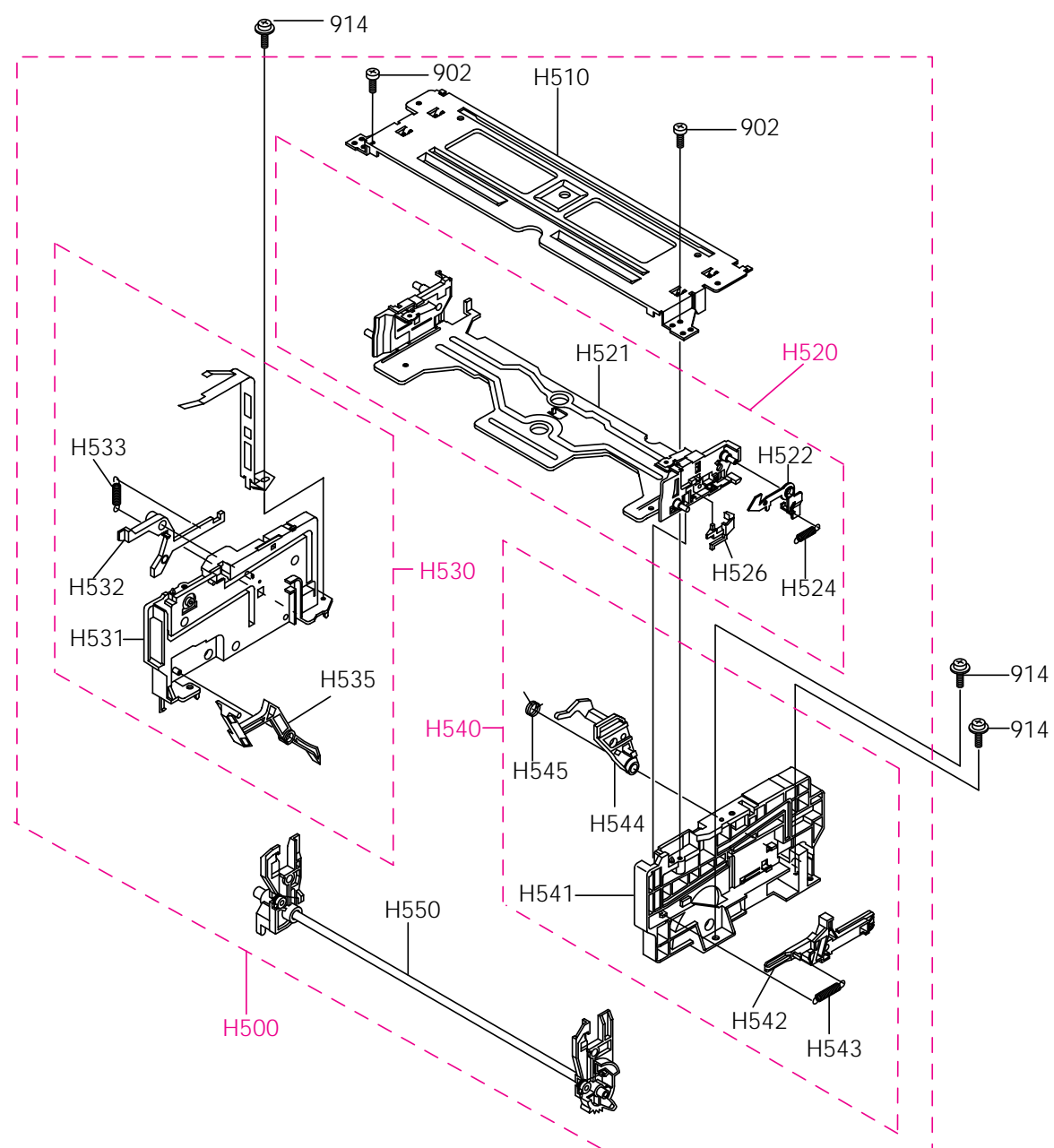

Loc. No	Part No	Description and Specification	Remark
902	AC60-10051A	SCREW-TAPPING;BH,-,-,M3,L8,FZY	
914	AC60-10067A	SCREW-TAPTITE;PWH,+,-,M3,L8,MFZN2-C,SWCH	
H500	AC61-82014D	HOUSING-ASSY;-X7FL26280B,230X130X60,-,X	
H510	AC61-10006A	CHASSIS- UPPER;SECC 20/20,-,T1.0,BLK,-,X	
H520	AC61-20932B	HOLDER-CASSETTE ASSY;-X5FL06080A,-,-,-,	
H521	AC61-20922B	HOLDER-CASSETTE;-SECC T1.2,-,NAT,-,X-7(
H522	AC66-30018A	LEVER-LOCK R;SECC 20/20,T1.2,L44,W32,-,-	
H524	AC61-60121A	SPRING-LEVER LOCK;ES,SUS304 WPB,PI0.2,D2	
H526	AC66-30019A	LEVER-KEY CASSETTE;LUCEL N109-LD,T2.5,L2	
H530	AC61-11033A	CHASSIS-SIDE L ASSY;-,-,-,-,X5FL0505A,	
H531	AC61-10004A	CHASSIS- SIDE L;ABS HF-380,-,T10,BLK,-,X	
H532	AC66-30004A	LEVER- LIGHT SHUTTER;LUCEL N109-LD,T2.5,	
H533	AC61-60142A	SPRING- LIGHT;ES,SUS304WPB,PI0.2,L11.4(O	
H535	AC66-30017A	LEVER- DOOR;LUCELN109-LD,T3.5,L74.3,W21.	
H540	AC61-11032A	CHASSIS-SIDE R ASSY;-,-,-,-,X5FL0505A,	
H541	AC61-10003A	CHASSIS- SIDE R;ABS HF-380,-,T10,BLK,-,X	
H542	AC66-80008A	SLIDER DAMPER;LUCEL N109-LD,T4,L87,-,-,-	
H543	AC61-60120A	SPRING-SLIDER;ES,SUS 304WPB,PI0.4,D3.8,L	
H544	AC66-30016A	LEVER- LID OPENER;LUCEL N109-LD,T4.0,L34	
H545	AC61-60123A	SPRING-LID OPENER;TS,SWPB,PI0.55,D8.9,L1	
H550	AC61-50654A	SHAFT-ARM ASSY;-SUM24L,-,-,-,-,X-5	

8. Electric Parts List

8-1 TB331VDZ1S/XSA (TB531VCT1 AND TB331VDZ1 Dissimilar Parts)

Loc. No.	Code No.	Description ; Specification	Remark	Loc. No.	Code No.	Description ; Specification	Remark
ASSY-PCB,MAIN(OPT)				ASSY-SPEAKER			
BUYER : SEAU				3001-001015 SPEAKER:2.5W,16ohm,88dB,150Hz AA39-20015D LEAD-CONNECTOR,ASSY:-,67096-003,-,3(2)P,300,1007#2			
*	AA94-10147	WASSY-PCB,MAIN(OPT);TB331VDZ1S/XSA,SCV11F,AUS		REMOCON			
C402	2201-000467	C-CERAMIC,DISC;330pF,10%,2KV,Y5P,TP,8x6,7.5		ASSY-CRT			
C403	2306-000327	C-FILM,MPPF;6.3nF,3%,1.6KV,TP,28.5x18x10,2		AA03-10002NCRT-COLOR:-,A34KQV42X,-,300MG,14,90DEG,5 AA27-00001A MAGNET-CONVERGENCE:-,JH225-06A,22.5MM AA27-50004X DEFLECTION-YOKE; AA63-60028A SPACER-DY;NEOPRENE,-,BLK,VO W12,-,-			
C404	2306-000195	C-FILM,MPPF;360nF,5%,400V,TP,26x19x11.5,20		ASSY-M/DECK			
C603	2401-000603	C-AL:1uF,20%,50V,GP,TP,5x11,5		ASSEMBLY (TB331)			
C605	2301-000445	C-FILM,PEF;4.7nF,5%,50V,TP,5.5x7x3mm,5mm		AA94-80003MASSY-M/DECK:M-320XK/SEG-S,2HD,PAL/MESECAM, AA91-40099A ASSY-DECK:-,2HD PAL/MESEC/SEC,DX-7A			
C607	2401-002144	C-AL:47uF,20%,16V,GP,TP,5x11,5		AA95-90009X ASSY-PCB,MASTER:DP,TVP3350,SCV11A/B,PAL,230V,1 AA95-90023N ASSY-PCB PAL:-,TVP5050X,SCV11D,TDA4665,-,- AA95-90023P ASSY-PCB SIF:-,TVP5050X,SCV11D,TDA3845,-,-			
C860	2401-002619	C-AL:47uF,20%,25V,GP,TP,5x11,5		ASSY-PCB,CRT			
CN601	3711-002642	CONNECTOR-HEADER;BOX,3P,1R,2.5mm,STRAIGHT,SN		AA95-20008U ASSY-PCB,CRT:-,SCV11D,14,NONE-EC,-			
IC601	1201-000535	IC-AUDIO AMP;7056,SIP,9P,-,SINGLE,40.5dB,PL		R501M 2002-001009 R-COMPOSITION:2.7Kohm,10%,1/2W,AA,TP,3.7X9.0 R502M 2002-001009 R-COMPOSITION:2.7Kohm,10%,1/2W,AA,TP,3.7X9.0 R505 2008-001015 R-FUSIBLE(S):1.5ohm,5%,2W,AF,TP,3.9x10mm V999 3704-000103 SOCKET-CRT;10P,22.5,14.3,SN,ISMS01S/BK			
L401	AA27-30001K	COIL-LINEARITY:-,230uH,DR1215,PI0.5,14.1x26,-		ASSY-PCB,A/V			
L803	AA27-20001L	COIL-DEGAUSSING;		AA95-40010U ASSY-PCB,A/V;DP,TVP3350F,SCV11D,-,MONO,FRAN			
Q401	0502-000443	TR-POWER;2SD1711YD,NPN,50W,TO-3PML,BK,3		CN701B AA39-20070F LEAD CONNECTOR-ASSY:-,YBNH025-07,67096-07,7P,500,1 CY701 2202-000807 C-CERAMIC,MLC-AXIAL:22nF,+80-20%,25V,Y5V,TP,3.5x19 CY704 2202-002037 C-CERAMIC,MLC-AXIAL:100nF,80-20%,50V,Y5V,TP,2.2x3. JA01 3722-000179 JACK-RCA;1P,3.4mm,SN,WHT,- JA02 3722-000182 JACK-RCA;1P,3.4mm,SN,YELLOW,- JA03 3722-000145 JACK-PHONE;1P,3.6mm,MBAG,BLK,- RY701 2001-001187 R-CARBON(S);75OHM,5%,1/2W,AA,TP,-			
Q601	0504-000119	TR-DIGITAL;KSR1004,NPN,300mW,47K-47K,TO-9		R705 2001-000674 R-CARBON:360OHM,5%,1/8W,AA,TP,- R711 2001-000674 R-CARBON:360OHM,5%,1/8W,AA,TP,- R712 2001-000780 R-CARBON:470OHM,5%,1/8W,AA,TP,- R927 2001-000429 R-CARBON:1KOHM,5%,1/8W,AA,TP,- T444 AA26-30002U TRANS-FLYBACK:-,FTK-14R005C,14,125V TU001 AA40-10005WTUNER-F/S;TECC2979PK28B(S),PAL-B/G,TR,18			
R103	2003-001027	R-METAL OXIDE(S);18ohm,5%,2W,AF,TP,3.9x10mm		R717 2001-000780 R-CARBON:470OHM,5%,1/8W,AA,TP,- R927 2001-000429 R-CARBON:1KOHM,5%,1/8W,AA,TP,- T444 AA26-30002U TRANS-FLYBACK:-,FTK-14R005C,14,125V TU001 AA40-10005WTUNER-F/S;TECC2979PK28B(S),PAL-B/G,TR,18			
R211	2001-000548	R-CARBON:270KOHM,5%,1/8W,AA,TP,-		R927 2001-000429 R-CARBON:1KOHM,5%,1/8W,AA,TP,- T444 AA26-30002U TRANS-FLYBACK:-,FTK-14R005C,14,125V TU001 AA40-10005WTUNER-F/S;TECC2979PK28B(S),PAL-B/G,TR,18			
R216	2001-000864	R-CARBON:56KOHM,5%,1/8W,AA,TP,-		R927 2001-000429 R-CARBON:1KOHM,5%,1/8W,AA,TP,- T444 AA26-30002U TRANS-FLYBACK:-,FTK-14R005C,14,125V TU001 AA40-10005WTUNER-F/S;TECC2979PK28B(S),PAL-B/G,TR,18			
R217	2001-000531	R-CARBON:240KOHM,5%,1/8W,AA,TP,-		R927 2001-000429 R-CARBON:1KOHM,5%,1/8W,AA,TP,- T444 AA26-30002U TRANS-FLYBACK:-,FTK-14R005C,14,125V TU001 AA40-10005WTUNER-F/S;TECC2979PK28B(S),PAL-B/G,TR,18			
R249	2001-000003	R-CARBON:330OHM,5%,1/8W,AA,TP,-		R927 2001-000429 R-CARBON:1KOHM,5%,1/8W,AA,TP,- T444 AA26-30002U TRANS-FLYBACK:-,FTK-14R005C,14,125V TU001 AA40-10005WTUNER-F/S;TECC2979PK28B(S),PAL-B/G,TR,18			
R250	2001-000515	R-CARBON:220OHM,5%,1/8W,AA,TP,-		R927 2001-000429 R-CARBON:1KOHM,5%,1/8W,AA,TP,- T444 AA26-30002U TRANS-FLYBACK:-,FTK-14R005C,14,125V TU001 AA40-10005WTUNER-F/S;TECC2979PK28B(S),PAL-B/G,TR,18			
R301	2001-000449	R-CARBON:2.2KOHM,5%,1/8W,AA,TP,-		R927 2001-000429 R-CARBON:1KOHM,5%,1/8W,AA,TP,- T444 AA26-30002U TRANS-FLYBACK:-,FTK-14R005C,14,125V TU001 AA40-10005WTUNER-F/S;TECC2979PK28B(S),PAL-B/G,TR,18			
R302	2001-001048	R-CARBON(S);1.2OHM,5%,1/2W,AA,TP,-		R927 2001-000429 R-CARBON:1KOHM,5%,1/8W,AA,TP,- T444 AA26-30002U TRANS-FLYBACK:-,FTK-14R005C,14,125V TU001 AA40-10005WTUNER-F/S;TECC2979PK28B(S),PAL-B/G,TR,18			
R304	2003-000652	R-METAL OXIDE(S);330ohm,5%,2W,AF,TP,4x12mm		R927 2001-000429 R-CARBON:1KOHM,5%,1/8W,AA,TP,- T444 AA26-30002U TRANS-FLYBACK:-,FTK-14R005C,14,125V TU001 AA40-10005WTUNER-F/S;TECC2979PK28B(S),PAL-B/G,TR,18			
R411	2004-001373	R-METAL(S);100Kohm,1%,1/2W,AA,TP,2.4x6.4m		R927 2001-000429 R-CARBON:1KOHM,5%,1/8W,AA,TP,- T444 AA26-30002U TRANS-FLYBACK:-,FTK-14R005C,14,125V TU001 AA40-10005WTUNER-F/S;TECC2979PK28B(S),PAL-B/G,TR,18			
R417	2008-001015	R-FUSIBLE(S):1.5ohm,5%,2W,AF,TP,3.9x10mm		R927 2001-000429 R-CARBON:1KOHM,5%,1/8W,AA,TP,- T444 AA26-30002U TRANS-FLYBACK:-,FTK-14R005C,14,125V TU001 AA40-10005WTUNER-F/S;TECC2979PK28B(S),PAL-B/G,TR,18			
R603	2001-001108	R-CARBON(S);22KOHM,5%,1/2W,AA,TP,-		R927 2001-000429 R-CARBON:1KOHM,5%,1/8W,AA,TP,- T444 AA26-30002U TRANS-FLYBACK:-,FTK-14R005C,14,125V TU001 AA40-10005WTUNER-F/S;TECC2979PK28B(S),PAL-B/G,TR,18			
R604	2001-000331	R-CARBON:12KOHM,5%,1/8W,AA,TP,-		R927 2001-000429 R-CARBON:1KOHM,5%,1/8W,AA,TP,- T444 AA26-30002U TRANS-FLYBACK:-,FTK-14R005C,14,125V TU001 AA40-10005WTUNER-F/S;TECC2979PK28B(S),PAL-B/G,TR,18			
R610	2006-000295	R-CEMENT;11ohm,5%,5W,CB,TP,9x13x25mm		R927 2001-000429 R-CARBON:1KOHM,5%,1/8W,AA,TP,- T444 AA26-30002U TRANS-FLYBACK:-,FTK-14R005C,14,125V TU001 AA40-10005WTUNER-F/S;TECC2979PK28B(S),PAL-B/G,TR,18			
R611	2006-001020	R-CEMENT;3.9ohm,5%,5W,CB,TP,10.5x14x23.		R927 2001-000429 R-CARBON:1KOHM,5%,1/8W,AA,TP,- T444 AA26-30002U TRANS-FLYBACK:-,FTK-14R005C,14,125V TU001 AA40-10005WTUNER-F/S;TECC2979PK28B(S),PAL-B/G,TR,18			
R615	2001-000331	R-CARBON:12KOHM,5%,1/8W,AA,TP,-		R927 2001-000429 R-CARBON:1KOHM,5%,1/8W,AA,TP,- T444 AA26-30002U TRANS-FLYBACK:-,FTK-14R005C,14,125V TU001 AA40-10005WTUNER-F/S;TECC2979PK28B(S),PAL-B/G,TR,18			
R705	2001-000674	R-CARBON:360OHM,5%,1/8W,AA,TP,-		R927 2001-000429 R-CARBON:1KOHM,5%,1/8W,AA,TP,- T444 AA26-30002U TRANS-FLYBACK:-,FTK-14R005C,14,125V TU001 AA40-10005WTUNER-F/S;TECC2979PK28B(S),PAL-B/G,TR,18			
R711	2001-000674	R-CARBON:360OHM,5%,1/8W,AA,TP,-		R927 2001-000429 R-CARBON:1KOHM,5%,1/8W,AA,TP,- T444 AA26-30002U TRANS-FLYBACK:-,FTK-14R005C,14,125V TU001 AA40-10005WTUNER-F/S;TECC2979PK28B(S),PAL-B/G,TR,18			
R712	2001-000780	R-CARBON:470OHM,5%,1/8W,AA,TP,-		R927 2001-000429 R-CARBON:1KOHM,5%,1/8W,AA,TP,- T444 AA26-30002U TRANS-FLYBACK:-,FTK-14R005C,14,125V TU001 AA40-10005WTUNER-F/S;TECC2979PK28B(S),PAL-B/G,TR,18			
R927	2001-000429	R-CARBON:1KOHM,5%,1/8W,AA,TP,-		R927 2001-000429 R-CARBON:1KOHM,5%,1/8W,AA,TP,- T444 AA26-30002U TRANS-FLYBACK:-,FTK-14R005C,14,125V TU001 AA40-10005WTUNER-F/S;TECC2979PK28B(S),PAL-B/G,TR,18			
T444	AA26-30002U	TRANS-FLYBACK:-,FTK-14R005C,14,125V		R927 2001-000429 R-CARBON:1KOHM,5%,1/8W,AA,TP,- T444 AA26-30002U TRANS-FLYBACK:-,FTK-14R005C,14,125V TU001 AA40-10005WTUNER-F/S;TECC2979PK28B(S),PAL-B/G,TR,18			
TU001	AA40-10005W	TUNER-F/S;TECC2979PK28B(S),PAL-B/G,TR,18		R927 2001-000429 R-CARBON:1KOHM,5%,1/8W,AA,TP,- T444 AA26-30002U TRANS-FLYBACK:-,FTK-14R005C,14,125V TU001 AA40-10005WTUNER-F/S;TECC2979PK28B(S),PAL-B/G,TR,18			

8-2 TB531VCT1X/XSA Parts List

Loc. No.	Code No.	Description ; Specification	Remark	Loc. No.	Code No.	Description ; Specification	Remark
		ASSY-PCB,MAIN(OPT)		C409	2401-002293	C-AL:68uF,20%,100V,WT,TP,10x20,5	
		BUYER : SEAU		C411	2201-000556	C-CERAMIC,DISC:470pF,10%,500V,Y5P,TP,7x4,5	
				C412	2401-000932	C-AL:22uF,20%,250V,LZ,TP,13x25mm,5m	
				C413	2301-000224	C-FILM,PEF:22nF,5%,50V,TP,7.4x3.9x13mm,5m	
				C414	2201-000984	C-CERAMIC,DISC:680pF,10%,2KV,Y5P,TP,11x6,7,5m	
				C415	2305-000382	C-FILM,MPEF:4.7nF,5%,400V,TP,-,5mm	
				C601	2401-001998	C-AL:1000uF,20%,25V,GP,TP,10x20,5mm	
				C602	2306-000122	C-FILM,MPPF:100nF,5%,50V,TP,7.3x4.0x5.0mm,	
				C603	2401-001333	C-AL:470nF,20%,50V,GP,TP,5x11,5	
				C604	2401-000603	C-AL:1uF,20%,50V,GP,TP,5x11,5	
				C605	2301-000314	C-FILM,PEF:8.2nF,5%,50V,TP,6.5x3.0x5.5mm,	
				C606	2401-002594	C-AL:220uF,20%,16V,GP,TP,8x11.5,5	
				C701	2401-000471	C-AL:10uF,20%,50V,BP,TP,5x11,5mm	
				C702	2401-001989	C-AL:4.7uF,20%,50V,BP,TP,5x11,5	
				C703	2202-000121	C-CERAMIC,MLC-AXIAL:100pF,10%,50V,Y5P,TP,1.9x3.5,-	
				C704	2202-000263	C-CERAMIC,MLC-AXIAL:470pF,10%,50V,Y5P,TP,3.5x19,-	
				C705	2401-001363	C-AL:470uF,20%,16V,GP,TP,10x12,5,5	
				C706	2401-000480	C-AL:10uF,20%,50V,GP,TP,5x11,5	
				C707	2401-000471	C-AL:10uF,20%,50V,BP,TP,5x11,5mm	
				C708	2401-000480	C-AL:10uF,20%,50V,GP,TP,5x11,5	
				C710	2401-000480	C-AL:10uF,20%,50V,GP,TP,5x11,5	
				C711	2401-000480	C-AL:10uF,20%,50V,GP,TP,5x11,5	
				C713	2401-002619	C-AL:47uF,20%,25V,GP,TP,5x11,5	
				C714	2401-002619	C-AL:47uF,20%,25V,GP,TP,5x11,5	
				C715	2401-000493	C-AL:10uF,20%,50V,LZ,TP,5x11mm,5mm	
				C717	2401-000471	C-AL:10uF,20%,50V,BP,TP,5x11,5mm	
				C718	2401-002619	C-AL:47uF,20%,25V,GP,TP,5x11,5	
				C724	2401-002619	C-AL:47uF,20%,25V,GP,TP,5x11,5	
				C725	2401-000480	C-AL:10uF,20%,50V,GP,TP,5x11,5	
				C726	2401-000471	C-AL:10uF,20%,50V,BP,TP,5x11,5mm	
				C729	2401-002619	C-AL:47uF,20%,25V,GP,TP,5x11,5	
				C730	2401-000480	C-AL:10uF,20%,50V,GP,TP,5x11,5	
				C800A	2201-000963	C-CERAMIC,DISC:1nF,20%,400V,Y5U,TP,11x8mm,10m	
				C800B	2201-000987	C-CERAMIC,DISC:2.2nF,20%,400V,Y5U,TP,15x8,10	
				C801	2306-000318	C-FILM,MPPF:220nF,20%,250V,TP,-,22.5mm	
				C802	2306-000318	C-FILM,MPPF:220nF,20%,250V,TP,-,22.5mm	
				C803	2201-000315	C-CERAMIC,DISC:2.2nF,+80-20%,250VAC,Y5U,TP,9x	
				C804	2201-000315	C-CERAMIC,DISC:2.2nF,+80-20%,250VAC,Y5U,TP,9x	
				C805	2201-000315	C-CERAMIC,DISC:2.2nF,+80-20%,250VAC,Y5U,TP,9x	
				C806	2201-000315	C-CERAMIC,DISC:2.2nF,+80-20%,250VAC,Y5U,TP,9x	
				C807	2401-002241	C-AL:220uF,+30-10%,400V,GP,ST,30x40	
				C808	2306-000323	C-FILM,MPPF:2.2nF,5%,1.6KV,TP,28.5x15.5x8.	
				C809	2401-002231	C-AL:470uF,20%,50V,WT,TP,13x20mm,5m	
				C810	2401-000903	C-AL:22uF,20%,160V,WT,TP,10x20mm,5m	
				C811	2401-002274	C-AL:220uF,20%,35V,WT,TP,10x12,5,5	
				C812	2301-000192	C-FILM,PEF:1nF,5%,50V,TP,5.3x10mm,5mm	
				C813	2201-000991	C-CERAMIC,DISC:560pF,10%,2KV,Y5P,TP,13x7,7,5	
				C814	2201-000991	C-CERAMIC,DISC:560pF,10%,2KV,Y5P,TP,13x7,7,5	
				C815	2201-000467	C-CERAMIC,DISC:330pF,10%,2KV,Y5P,TP,8x6,7,5	
				C816	2201-000991	C-CERAMIC,DISC:560pF,10%,2KV,Y5P,TP,13x7,7,5	
				C818	2201-000984	C-CERAMIC,DISC:680pF,10%,2KV,Y5P,TP,11x6,7,5m	
				C819	2401-003058	C-AL:100uF,20%,200V,WT,TP,16x25,7,5	
				C820	2401-003058	C-AL:100uF,20%,200V,WT,TP,16x25,7,5	
				C822	2401-001570	C-AL:47uF,20%,50V,WT,TP,10x20mm,5mm	
				C823	2401-002293	C-AL:68uF,20%,100V,WT,TP,10x20,5	
				C824	2401-000142	C-AL:1000uF,20%,16V,WT,TP,10x20,5	
				C825	2401-000722	C-AL:2200uF,20%,25V,WT,TP,16x25,7,5	
				C826	2401-000318	C-AL:100uF,20%,25V,LZ,TP,8x11.5,5	
				C827	2201-000467	C-CERAMIC,DISC:330pF,10%,2KV,Y5P,TP,8x6,7,5	
				C828	2401-001363	C-AL:470uF,20%,16V,GP,TP,10x12,5,5	
				C829	2306-000122	C-FILM,MPPF:100nF,5%,50V,TP,7.3x4.0x5.0mm,	
				C830	2306-000122	C-FILM,MPPF:100nF,5%,50V,TP,7.3x4.0x5.0mm,	
				C831	2401-001363	C-AL:470uF,20%,16V,GP,TP,10x12,5,5	
				C832	2306-000122	C-FILM,MPPF:100nF,5%,50V,TP,7.3x4.0x5.0mm,	
				C833	2401-002288	C-AL:470uF,20%,25V,WT,TP,10x20,5	
				C834	2306-000122	C-FILM,MPPF:100nF,5%,50V,TP,7.3x4.0x5.0mm,	
				C835	2401-001397	C-AL:470uF,20%,25V,GP,TP,10x16,5	
				C836	2306-000122	C-FILM,MPPF:100nF,5%,50V,TP,7.3x4.0x5.0mm,	
				C838	2401-000164	C-AL:1000uF,20%,25V,WT,TP,12.5x20,5	
				C839	2401-001397	C-AL:470uF,20%,25V,GP,TP,10x16,5	
				C840	2305-000411	C-FILM,MPEF:470nF,5%,50V,TP,7.3x4.8x5.5mm,	
				C842	2401-001998	C-AL:1000uF,20%,25V,GP,TP,10x20,5mm	
				C844	2401-002594	C-AL:220uF,20%,16V,GP,TP,8x11,5,5	
C101	2401-000947	C-AL:22uF,20%,35V,GP,TP,5x11,5					
C102	2401-000832	C-AL:220uF,20%,25V,GP,TP,8x11.5,5					
C103	2306-000122	C-FILM,MPPF:100nF,5%,50V,TP,7.3x4.0x5.0mm,					
C104	2401-001840	C-AL:100uF,20%,16V,GP,TP,6.3x11,5					
C105	2202-002037	C-CERAMIC,MLC-AXIAL:100nF,80-20%,50V,Y5V,TP,2.2x3.					
C106	2202-000127	C-CERAMIC,MLC-AXIAL:10nF,+80-20%,25V,Y5V,TP,-,7.5					
C107	2202-000807	C-CERAMIC,MLC-AXIAL:22nF,+80-20%,25V,Y5V,TP,3.5x19					
C108	2401-000962	C-AL:22uF,20%,50V,GP,TP,5x11,5					
C109	2202-000127	C-CERAMIC,MLC-AXIAL:10nF,+80-20%,25V,Y5V,TP,-,7.5					
C112	2305-000196	C-FILM,MPEF:150nF,5%,63V,TP,-,5mm					
C113	2202-000127	C-CERAMIC,MLC-AXIAL:10nF,+80-20%,25V,Y5V,TP,-,7.5					
C116	2306-000122	C-FILM,MPPF:100nF,5%,50V,TP,7.3x4.0x5.0mm,					
C201	2401-002619	C-AL:47uF,20%,25V,GP,TP,5x11,5					
C202	2401-002619	C-AL:47uF,20%,25V,GP,TP,5x11,5					
C204	2301-000224	C-FILM,PEF:22nF,5%,50V,TP,7.4x3.9x13mm,5m					
C205	2401-000660	C-AL:2.2uF,20%,50V,GP,TP,5x11,5					
C206	2306-000122	C-FILM,MPPF:100nF,5%,50V,TP,7.3x4.0x5.0mm,					
C207	2401-001840	C-AL:100uF,20%,16V,GP,TP,6.3x11,5					
C208	2305-000411	C-FILM,MPEF:470nF,5%,50V,TP,7.3x4.8x5.5mm,					
C209	2306-000122	C-FILM,MPPF:100nF,5%,50V,TP,7.3x4.0x5.0mm,					
C210	2305-000411	C-FILM,MPEF:470nF,5%,50V,TP,7.3x4.8x5.5mm,					
C211	2301-000232	C-FILM,PEF:3.3nF,5%,50V,TP,8.1x4.5x13mm,5					
C212	2306-000122	C-FILM,MPPF:100nF,5%,50V,TP,7.3x4.0x5.0mm,					
C213	2306-000122	C-FILM,MPPF:100nF,5%,50V,TP,7.3x4.0x5.0mm,					
C214	2306-000122	C-FILM,MPPF:100nF,5%,50V,TP,7.3x4.0x5.0mm,					
C215	2401-001625	C-AL:6.8uF,20%,50V,GP,TP,5x11,5					
C219	2201-000273	C-CERAMIC,DISC:18pF,5%,50V,CH,TP,5x3mm,5					
C221	2306-000122	C-FILM,MPPF:100nF,5%,50V,TP,7.3x4.0x5.0mm,					
C222	2401-000302	C-AL:100uF,20%,25V,GP,TP,6.3x11,5					
C225	2401-002144	C-AL:47uF,20%,16V,GP,TP,5x11,5					
C226	2401-000603	C-AL:1uF,20%,50V,GP,TP,5x11,5					
C227	2202-000796	C-CERAMIC,MLC-AXIAL:1nF,10%,50V,Y5P,TP,3.5X1.9MM,-					
C228	2309-000138	C-FILM,PE-PF:100nF,5%,50V,TP,20x16x8,5,7,5m					
C229	2306-000122	C-FILM,MPPF:100nF,5%,50V,TP,7.3x4.0x5.0mm,					
C230	2306-000122	C-FILM,MPPF:100nF,5%,50V,TP,7.3x4.0x5.0mm,					
C231	2401-001333	C-AL:470nF,20%,50V,GP,TP,5x11,5					
C232	2201-000976	C-CERAMIC,DISC:22pF,5%,50V,CH,TP,5.0x3.0,5mm					
C233	2202-000286	C-CERAMIC,MLC-AXIAL:56pF,5%,50V,SL,TP,1.9x3.5,-					
C234	2301-000445	C-FILM,PEF:4.7nF,5%,50V,TP,5.5x7x3mm,5mm					
C236	2301-000204	C-FILM,PEF:2.7nF,5%,50V,TP,7.4x3.9x13mm,5					
C238	2301-000342	C-FILM,PEF:2.2nF,5%,50V,TP,7.4x3.9x13mm,5					
C239	2401-000603	C-AL:1uF,20%,50V,GP,TP,5x11,5					
C249	2401-000480	C-AL:10uF,20%,50V,GP,TP,5x11,5					
C250	2306-000122	C-FILM,MPPF:100nF,5%,50V,TP,7.3x4.0x5.0mm,					
C251	2301-000247	C-FILM,PEF:33nF,5%,50V,TP,8.1x4.5x13mm,5m					
C252	2201-000980	C-CERAMIC,DISC:30pF,5%,50V,CH,TP,5.0x3.0,5mm					
C253	2202-000807	C-CERAMIC,MLC-AXIAL:22nF,+80-20%,25V,Y5V,TP,3.5x19					
C254	2202-000127	C-CERAMIC,MLC-AXIAL:10nF,+80-20%,25V,Y5V,TP,-,7.5					
C255	2401-002619	C-AL:47uF,20%,25V,GP,TP,5x11,5					
C257	2202-000791	C-CERAMIC,MLC-AXIAL:150pF,10%,50V,Y5P,TP,3.5x19,-					
C258	2202-000127	C-CERAMIC,MLC-AXIAL:10nF,+80-20%,25V,Y5V,TP,-,7.5					
C301	2202-000796	C-CERAMIC,MLC-AXIAL:1nF,10%,50V,Y5P,TP,3.5X1.9MM,-					
C302	2401-003140	C-AL:47uF,20%,50V,WT/NP,TP,10x20,5					
C303	2305-000149	C-FILM,MPEF:100nF,5%,100V,TP,12x12.5x6,5,5					
C304	2305-000285	C-FILM,MPEF:220nF,5%,100V,TP,20x18x11,5,15					
C305	2202-000796	C-CERAMIC,MLC-AXIAL:1nF,10%,50V,Y5P,TP,3.5X1.9MM,-					

Loc. No.	Code No.	Description ; Specification	Remark	Loc. No.	Code No.	Description ; Specification	Remark
C845	2401-002288	C-AL:470uF,20%,25V,WT,TP,10x20,5		D912	0401-000005	DIODE-SWITCHING:1N4148,75V,300mA,DO-35,TP	
C846	2401-001363	C-AL:470uF,20%,16V,GP,TP,10x12,5,5		D913	0401-000005	DIODE-SWITCHING:1N4148,75V,300mA,DO-35,TP	
C850	2401-001101	C-AL:330uF,20%,16V,GP,TP,8x11,5,5		D914	0401-000005	DIODE-SWITCHING:1N4148,75V,300mA,DO-35,TP	
C852	2401-000318	C-AL:100uF,20%,25V,LZ,TP,8x11,5,5		D916	0401-000005	DIODE-SWITCHING:1N4148,75V,300mA,DO-35,TP	
C853	2401-001397	C-AL:470uF,20%,25V,GP,TP,10x16,5		D919	0401-000005	DIODE-SWITCHING:1N4148,75V,300mA,DO-35,TP	
C855	2301-000192	C-FILM,PEF:1nF,5%,50V,TP,5.3x10mm,5mm		D921	0401-000005	DIODE-SWITCHING:1N4148,75V,300mA,DO-35,TP	
C856	2306-000122	C-FILM,MPPF:100nF,5%,50V,TP,7.3x4.0x5.0mm,		D922	0402-000132	DIODE-RECTIFIER:1N4004,400V,1A,DO-41,TP	
C859	2306-000122	C-FILM,MPPF:100nF,5%,50V,TP,7.3x4.0x5.0mm,		DK01	0401-000005	DIODE-SWITCHING:1N4148,75V,300mA,DO-35,TP	
C901	2202-000796	C-CERAMIC,MLC-AXIAL:1nF,10%,50V,Y5P,TP,3.5x1.9MM,-		DZ101	0403-000563	DIODE-ZENER:MTZ9.1B,9.1V,8.57-9.01V,500mW,	
C902	2201-000247	C-CERAMIC,DISC:15pF,5%,50V,CH,TP,5x3,5		DZ201	0403-000296	DIODE-ZENER:MTZ5.6B,5.6V,5.45-5.73V,500mW,	
C903	2401-001333	C-AL:470nF,20%,50V,GP,TP,5x11,5		DZ301	0403-000660	DIODE-ZENER:MTZ22A,22V,20.15-21.2V,500mW,D	
C904	2201-000247	C-CERAMIC,DISC:15pF,5%,50V,CH,TP,5x3,5		DZ302	0403-000700	DIODE-ZENER:TZP33A,33V,31-35V,1W,DO-41,TP	
C905	2301-000227	C-FILM,PEF:27nF,5%,50V,TP,7x3.5x6.5mm,5mm		DZ303	0403-001039	DIODE-ZENER:MA2560,56V,52-60V,1W,DO-41,TP	
C906	2401-000030	C-AL:22uF,20%,25V,GP,TP,5x11,5		DZ304	0403-000656	DIODE-ZENER:MTZ15C,15V,14.35-15.09V,500mW,	
C907	2201-000423	C-CERAMIC,DISC:27pF,5%,50V,NPO,TP,5x3,2,5		DZ702	0403-000563	DIODE-ZENER:MTZ9.1B,9.1V,8.57-9.01V,500mW,	
C908	2306-000122	C-FILM,MPPF:100nF,5%,50V,TP,7.3x4.0x5.0mm,		DZ704	0403-000563	DIODE-ZENER:MTZ9.1B,9.1V,8.57-9.01V,500mW,	
C915	2306-000122	C-FILM,MPPF:100nF,5%,50V,TP,7.3x4.0x5.0mm,		DZ801	1405-000152	VARISTOR:560V,2500A,14x8.5mm,TP	
C916	2401-002594	C-AL:220uF,20%,16V,GP,TP,8x11,5,5		DZ802	0403-000299	DIODE-ZENER:MTZ7.5C,7.5V,7.29-7.67V,500mW,	
C917	2201-000982	C-CERAMIC,DISC:10nF,+80-20%,50V,Y5V,TP,6,5x3,		DZ803	0403-000700	DIODE-ZENER:TZP33A,33V,31-35V,1W,DO-41,TP	
C918	2401-000480	C-AL:10uF,20%,50V,GP,TP,5x11,5		DZ804	0403-000654	DIODE-ZENER:MTZ12B,12V,11.44-12.03V,500mW,	
C920	2301-000192	C-FILM,PEF:1nF,5%,50V,TP,5.3x10mm,5mm		DZ805	0403-000658	DIODE-ZENER:MTZ18A,18V,16.22-17.06V,500mW,	
C921	2401-001333	C-AL:470nF,20%,50V,GP,TP,5x11,5		DZ807	0403-000563	DIODE-ZENER:MTZ9.1B,9.1V,8.57-9.01V,500mW,	
CB03	2202-000127	C-CERAMIC,MLC-AXIAL:10nF,+80-20%,25V,Y5V,TP,-,7.5		DZ808	0403-000662	DIODE-ZENER:MTZ3.0B,3.0V,3.01-3.22V,500mW,	
CK01	2202-000121	C-CERAMIC,MLC-AXIAL:100pF,10%,50V,Y5P,TP,1.9x3.5,-		DZ809	0403-000656	DIODE-ZENER:MTZ15C,15V,14.35-15.09V,500mW,	
CN101	3711-002647	CONNECTOR-HEADER:BOX,8P,1R,2.5mm,STRAIGHT,SN		DZ901	0403-000355	DIODE-ZENER:MTZ5.1BSB,5.1V,4.97-5.18V,500mW,	
CN102	3711-003641	CONNECTOR-HEADER:BOX,12P,1R,2.5mm,STRAIGHT,SN		DZ902	0403-000297	DIODE-ZENER:MTZ6.2B,6.2V,5.96-6.27V,500mW,	
CN501C	3711-002648	CONNECTOR-HEADER:BOX,9P,1R,2.5mm,STRAIGHT,SN		DZ904	0403-000300	DIODE-ZENER:MTZ8.2B,8.2V,7.78-8.19V,500mW,	
CN701	3711-002646	CONNECTOR-HEADER:BOX,7P,1R,2.5mm,STRAIGHT,SN		DZ905	0403-000355	DIODE-ZENER:MTZ5.1BSB,5.1V,4.97-5.18V,500mW,	
CN701A	3711-002643	CONNECTOR-HEADER:BOX,4P,1R,2.5mm,STRAIGHT,SN		DZ906	0403-000296	DIODE-ZENER:MTZ5.6B,5.6V,5.45-5.73V,500mW,	
CN901	3711-002644	CONNECTOR-HEADER:BOX,5P,1R,2.5mm,STRAIGHT,SN		△ F801	3601-000261	FUSE-FERRULE:250V,3.15A,TL,GLASS,5.2x20mm	
CNW901	2503-000154	C-NETWORK:100pF,20%,50V		F81	3602-000114	FUSE-HOLDER:-,30mohm	
CU101	2401-002594	C-AL:220uF,20%,16V,GP,TP,8x11,5,5		F82	3602-000114	FUSE-HOLDER:-,30mohm	
CU102	2401-002594	C-AL:220uF,20%,16V,GP,TP,8x11,5,5		GT02A	AA39-20010B	LEAD-CONNECTOR,ASSY:-,YFH800-01,S,1P,500,1617#22	
CU103	2306-000122	C-FILM,MPPF:100nF,5%,50V,TP,7.3x4.0x5.0mm,		△ HC001	AA13-20004A	IC-HYBRID:-,PAP102T,SIP,6PPRE-AMP,TP	
CU104	2306-000122	C-FILM,MPPF:100nF,5%,50V,TP,7.3x4.0x5.0mm,		△ IC201	1204-001191	IC-PAL/NTSC PROCESS:TD8374A(N3),DIP,56P,-,PLASTIC	
CU105	2202-000807	C-CERAMIC,MLC-AXIAL:22nF,+80-20%,25V,Y5V,TP,3.5x19		△ IC301	1204-000441	IC-IF CIRCUIT:TD8356,SIP,9P,-,PLASTIC,40V,-	
D102	0401-000005	DIODE-SWITCHING:1N4148,75V,300mA,DO-35,TP		△ IC601	1201-000537	IC-AUDIO AMP:7057,ZIP,13P,-,DUAL,40dB,PLAST	
D205	0401-000005	DIODE-SWITCHING:1N4148,75V,300mA,DO-35,TP		△ IC701	0801-000961	IC-CMOS LOGIC:4053,MULTIPLEXER,DIP,16P,300MIL	
D209	0401-000005	DIODE-SWITCHING:1N4148,75V,300mA,DO-35,TP		△ IC702	1001-000227	IC-VIDEO SWITCH:KA8405,SP3T CMOS,SIP,9P,250MIL	
D401	0402-000132	DIODE-RECTIFIER:1N4004,400V,1A,DO-41,TP		△ IC703	1001-000227	IC-VIDEO SWITCH:KA8405,SP3T CMOS,SIP,9P,250MIL	
D402	0402-000132	DIODE-RECTIFIER:1N4004,400V,1A,DO-41,TP		△ IC704	1001-000216	IC-RF/V1/AUDIO S/W:KA8404,SPDT CMOS,SIP,7P,-,SING	
D403	0402-000546	DIODE-RECTIFIER:TVR10G,400V,1.0A,DO-41,TP		△ IC801	0604-001032	PHOTO-COUPLEDER:TR,170-260%,300mW,DIP-4,ST	
D404	0402-000540	DIODE-RECTIFIER:RU20A,600V,1.5A,-,TP		△ IC804	1203-000284	IC-POSI.FIXED REG.:7806,TO-220,3P,-,PLASTIC,5.75/	
D405	0402-000546	DIODE-RECTIFIER:TVR10G,400V,1.0A,DO-41,TP		△ IC805	1203-000243	IC-POSI.FIXED REG.:7812A,TO-220,3P,-,PLASTIC,11.5	
D407	0402-000132	DIODE-RECTIFIER:1N4004,400V,1A,DO-41,TP		△ IC806	1203-000243	IC-POSI.FIXED REG.:7812A,TO-220,3P,-,PLASTIC,11.5	
D801	0402-000532	DIODE-RECTIFIER:ERC13-08,800V,1.2A,DO-204		△ IC811	1203-000006	IC-POSI.FIXED REG.:7808,TO-220,3P,-,PLASTIC,7.7/8	
D802	0402-000532	DIODE-RECTIFIER:ERC13-08,800V,1.2A,DO-204		△ IC812	1203-000284	IC-POSI.FIXED REG.:7806,TO-220,3P,-,PLASTIC,5.75/	
D803	0402-000532	DIODE-RECTIFIER:ERC13-08,800V,1.2A,DO-204		△ IC901	AA13-30019J	IC-MCU:-,CXP85332A-323S,8BIT,SDIP,TF5	
D804	0402-000532	DIODE-RECTIFIER:ERC13-08,800V,1.2A,DO-204		△ IC902	1103-000156	IC-EEPROM:24C04,512x8BIT,DIP,8P,300MIL,1	
D805	0402-000546	DIODE-RECTIFIER:TVR10G,400V,1.0A,DO-41,TP		△ IC903	1202-000001	IC-VOLTAGE COMP:7533,TO-92,3P,-,SINGLE,-,PLA	
D806	0402-000546	DIODE-RECTIFIER:TVR10G,400V,1.0A,DO-41,TP		△ ICU101	1203-000274	IC-POSI.FIXED REG.:7805,TO-220,3P,-,PLASTIC,4.8/5	
D807	0402-000546	DIODE-RECTIFIER:TVR10G,400V,1.0A,DO-41,TP		IF/CAB	AA39-30007A	IF-CABLE:-,T,100mm,1365#26	
D808	0402-000546	DIODE-RECTIFIER:TVR10G,400V,1.0A,DO-41,TP		J140	2202-000806	C-CERAMIC,MLC-AXIAL:220pF,10%,50V,Y5V,TP,3.5x19,-	
D809	0402-000546	DIODE-RECTIFIER:TVR10G,400V,1.0A,DO-41,TP		JS701	3722-000161	JACK-PIN:2P,3.4mm,SN,BLK,-	
D810	0402-000546	DIODE-RECTIFIER:TVR10G,400V,1.0A,DO-41,TP		L101	2701-000326	INDUCTOR-AXIAL:560nH,10%,2.3x3.4mm	
D811	0402-000493	DIODE-RECTIFIER:1R5GU41,400V,1.5A,DO-15L,TP		L102	2701-000114	INDUCTOR-AXIAL:10uH,10%,2.5x3.4mm	
D812	0402-000250	DIODE-RECTIFIER:RG4C,1000V,1A,-		L103	2701-000114	INDUCTOR-AXIAL:10uH,10%,2.5x3.4mm	
D813	0402-000493	DIODE-RECTIFIER:1R5GU41,400V,1.5A,DO-15L,TP		L104	2701-000114	INDUCTOR-AXIAL:10uH,10%,2.5x3.4mm	
D814	0402-000493	DIODE-RECTIFIER:1R5GU41,400V,1.5A,DO-15L,TP		L105	2701-000114	INDUCTOR-AXIAL:10uH,10%,2.5x3.4mm	
D815	0401-000005	DIODE-SWITCHING:1N4148,75V,300mA,DO-35,TP		L106	2701-000114	INDUCTOR-AXIAL:10uH,10%,2.5x3.4mm	
D817	0402-000493	DIODE-RECTIFIER:1R5GU41,400V,1.5A,DO-15L,TP		L108	2701-000180	INDUCTOR-AXIAL:33uH,5%,2.5x3.4mm	
D818	0402-000233	DIODE-RECTIFIER:FML-G12S,200V,5A,-		L201	2701-000168	INDUCTOR-AXIAL:3.3uH,5%,2.5x3.4mm	
D820	0402-000493	DIODE-RECTIFIER:1R5GU41,400V,1.5A,DO-15L,TP		L205	2701-000114	INDUCTOR-AXIAL:10uH,10%,2.5x3.4mm	
D821	0401-000005	DIODE-SWITCHING:1N4148,75V,300mA,DO-35,TP		L206	2701-000116	INDUCTOR-AXIAL:10uH,10%,4.2x9.8mm	
D827	0402-000546	DIODE-RECTIFIER:TVR10G,400V,1.0A,DO-41,TP		L301	AA27-10001E	COIL-CHOKE:-,1.0uH,K,25,2100A,T,SP0408-1R	
D829	0401-000005	DIODE-SWITCHING:1N4148,75V,300mA,DO-35,TP		L302	AA27-10001E	COIL-CHOKE:-,1.0uH,K,25,2100A,T,SP0408-1R	
D831	0401-000005	DIODE-SWITCHING:1N4148,75V,300mA,DO-35,TP		L303	2701-000114	INDUCTOR-AXIAL:10uH,10%,2.5x3.4mm	
D833	0401-000005	DIODE-SWITCHING:1N4148,75V,300mA,DO-35,TP		L304	2701-000114	INDUCTOR-AXIAL:10uH,10%,2.5x3.4mm	
D836	0402-000132	DIODE-RECTIFIER:1N4004,400V,1A,DO-41,TP		L305	2701-000116	INDUCTOR-AXIAL:10uH,10%,4.2x9.8mm	
D837	0402-000546	DIODE-RECTIFIER:TVR10G,400V,1.0A,DO-41,TP		L306	2701-000116	INDUCTOR-AXIAL:10uH,10%,4.2x9.8mm	
D850	0402-000546	DIODE-RECTIFIER:TVR10G,400V,1.0A,DO-41,TP		L401	AA27-30001B	COIL-LINEARITY:-,195uH,QIC1010,PIO,4,4.5x21.5	
D851	0402-000546	DIODE-RECTIFIER:TVR10G,400V,1.0A,DO-41,TP		L403	2901-000297	FILTER-EMI ON BOARD:-,3A,-,3.5x5,TP,-	
D901	0401-000005	DIODE-SWITCHING:1N4148,75V,300mA,DO-35,TP		L404	AA27-40001N	COIL-HORIZ.WIDTH:-,90/260uH,SB-55620,PIO,8,-	
D906	0401-000005	DIODE-SWITCHING:1N4148,75V,300mA,DO-35,TP		L405	AA27-10002X	COIL-CHOKE:-,43uH,K,10,1A,T,43UH-K(SPT050	
D908	0401-000005	DIODE-SWITCHING:1N4148,75V,300mA,DO-35,TP		L701	2701-000114	INDUCTOR-AXIAL:10uH,10%,2.5x3.4mm	
D909	0401-000005	DIODE-SWITCHING:1N4148,75V,300mA,DO-35,TP		L704	2901-000297	FILTER-EMI ON BOARD:-,3A,-,3.5x5,TP,-	
D910	0401-000005	DIODE-SWITCHING:1N4148,75V,300mA,DO-35,TP		L801	AA29-30001C	FILTER-LINE:-,39mH,1.0A,-,-	

Electric Parts List

Loc. No.	Code No.	Description ; Specification	Remark	Loc. No.	Code No.	Description ; Specification	Remark
L803	AA27-20001Z	COIL-DEGAUSSING:-,21,14.5ohm,35T,L2500,E		R305	2001-000085	R-CARBON(S):100KOHM,5%,1/2W,AA,TP,-	
L805	3301-000287	CORE-FERRITE BEAD:AA,3.5x1.0x6.0mm,1500,2400G		R306	2008-000254	R-FUSIBLE(S):0.68ohm,5%,2W,AF,TP,3.9x10mm	
L808	2901-000299	FILTER-EMI ON BOARD:-,6A,UL/CSA,-,9x7.5,TP,-		R401	2001-000281	R-CARBON:100OHM,5%,1/8W,AA,TP,-	
L809	2901-000299	FILTER-EMI ON BOARD:-,6A,UL/CSA,-,9x7.5,TP,-		R402	2001-000591	R-CARBON:3.3KOHM,5%,1/8W,AA,TP,-	
L810	AA27-10002Y	COIL-CHOKE:-,100uH,K,10,700mA,T,100UH-K(S)		R403	2001-001114	R-CARBON(S):2700HM,5%,1/2W,AA,TP,-	
L811	2901-000299	FILTER-EMI ON BOARD:-,6A,UL/CSA,-,9x7.5,TP,-		R404	2003-000713	R-METAL OXIDE(S):47ohm,5%,2W,AF,TP,4x12mm	
L812	AA27-10002Y	COIL-CHOKE:-,100uH,K,10,700mA,T,100UH-K(S)		R405	2003-000540	R-METAL OXIDE(S):1Kohm,5%,2W,AF,TP,4x12mm	
L813	3301-000287	CORE-FERRITE BEAD:AA,3.5x1.0x6.0mm,1500,2400G		R407	2004-001373	R-METAL(S):100Kohm,1%,1/2W,AA,TP,2.4x6.4mm	
L814	2901-000297	FILTER-EMI ON BOARD:-,3A,-,3.5x5,TP,-		R408	2008-000264	R-FUSIBLE(S):1ohm,5%,1W,AF,TP,3.9x10mm	
L818	2901-000297	FILTER-EMI ON BOARD:-,3A,-,3.5x5,TP,-		R409	2008-000204	R-FUSIBLE(S):0.22ohm,10%,1/2W,AF,TP,2.5x6.5	
L902	AA27-10003G	COIL-CHOKE:-,30uH,K,50,22.3mA,TP,EL0606RA		R410	2008-000264	R-FUSIBLE(S):1ohm,5%,1W,AF,TP,3.9x10mm	
L904	2701-000114	INDUCTOR-AXIAL:10uH,10%,2.5x3.4mm		R411	2004-001408	R-METAL(S):91Kohm,1%,1/2W,AA,TP,2.4x6.4mm	
L905	3301-000287	CORE-FERRITE BEAD:AA,3.5x1.0x6.0mm,1500,2400G		R412	2004-001390	R-METAL(S):1Kohm,2%,1/2W,AA,TP,2.4x6.4mm	
Q201	0501-000389	TR-SMALL SIGNAL:KSC815,NPN,400mW,TO-92,TP,120-		R413	2001-001037	R-CARBON(S):0.390HM,5%,1/2W,AA,TP,-	
Q202	0501-000389	TR-SMALL SIGNAL:KSC815,NPN,400mW,TO-92,TP,120-		R414	2001-000022	R-CARBON(S):330HM,5%,1/2W,AA,TP,-	
Q203	0501-000283	TR-SMALL SIGNAL:KSA539,PNP,400mW,TO-92,TP,120-		R415	2003-000993	R-METAL OXIDE(S):3.9Kohm,5%,1W,AF,TP,2.5x6.5mm	
Q204	0501-000389	TR-SMALL SIGNAL:KSC815,NPN,400mW,TO-92,TP,120-		R416	2008-000253	R-FUSIBLE(S):0.47ohm,5%,1W,AF,TP,3.9x10mm	
Q207	0501-000389	TR-SMALL SIGNAL:KSC815,NPN,400mW,TO-92,TP,120-		R417	2008-000254	R-FUSIBLE(S):0.68ohm,5%,2W,AF,TP,3.9x10mm	
Q401	0502-000295	TR-POWER:KSD5072YD,NPN,1500V,800V,5A,60		R418	2003-000649	R-METAL OXIDE(S):330ohm,5%,1W,AF,TP,3.3x9mm	
Q402	0501-000369	TR-SMALL SIGNAL:KSC2331-Y,NPN,1W,TO-92L,-,120-		R419	2001-000563	R-CARBON:27KOHM,5%,1/8W,AA,TP,-	
Q601	0504-000123	TR-DIGITAL:KSR1010,NPN,300mW,10K,TO-92,TP		R420	2004-001234	R-METAL:75Kohm,5%,1/8W,AA,TP,1.8x3.2mm	
Q701	0501-000283	TR-SMALL SIGNAL:KSA539,PNP,400mW,TO-92,TP,120-		R421	2008-000299	R-FUSIBLE(S):47ohm,5%,2W,AF,TP,3.9x10mm	
Q703	0501-000389	TR-SMALL SIGNAL:KSC815,NPN,400mW,TO-92,TP,120-		R422	2008-000299	R-FUSIBLE(S):47ohm,5%,2W,AF,TP,3.9x10mm	
Q801	AA13-20002HC	HYBRID:-,STRS6707,SIP,9P,SMPS CONTROL		R604	2001-000008	R-CARBON:15KOHM,5%,1/8W,AA,TP,-	
Q802	0503-000153	TR-DARLINGTON:TP102,NPN,2W,TO-220,TP,1000-2		R605	2001-000429	R-CARBON:1KOHM,5%,1/8W,AA,TP,-	
Q803	AA13-20002L	IC-HYBRID:-,SE125N,SIP,3P,ERROR AMP		R606	2001-000241	R-CARBON:1.5KOHM,5%,1/8W,AA,TP,-	
Q804	0501-000366	TR-SMALL SIGNAL:KSC2330-Y,NPN,1W,TO-92L,-,70-1		R607	2001-000290	R-CARBON:10KOHM,5%,1/8W,AA,TP,-	
Q805	0502-000244	TR-POWER:KSA940,PNP,1.5W,TO-220,-,40-14		R608	2001-000007	R-CARBON:3KOHM,5%,1/8W,AA,TP,-	
Q806	0504-000119	TR-DIGITAL:KSR1004,NPN,300mW,47K-47K,TO-9		R609	2001-000429	R-CARBON:1KOHM,5%,1/8W,AA,TP,-	
Q807	0501-000366	TR-SMALL SIGNAL:KSC2330-Y,NPN,1W,TO-92L,-,70-1		R612	2008-000256	R-FUSIBLE(S):1.5ohm,5%,2W,AA,TP,3.9x10mm	
Q901	0501-000389	TR-SMALL SIGNAL:KSC815,NPN,400mW,TO-92,TP,120-		R613	2008-000256	R-FUSIBLE(S):1.5ohm,5%,2W,AA,TP,3.9x10mm	
Q902	1202-000001	IC-VOLTAGE COMP:7533,TO-92,3P,-,SINGLE,-,PLA		R614	2006-001002	R-CEMENT:1.2ohm,5%,5W,CB,TP,9x13x25mm	
Q903	0501-000389	TR-SMALL SIGNAL:KSC815,NPN,400mW,TO-92,TP,120-		R615	2001-000008	R-CARBON:15KOHM,5%,1/8W,AA,TP,-	
Q904	0501-000389	TR-SMALL SIGNAL:KSC815,NPN,400mW,TO-92,TP,120-		R701	2001-000281	R-CARBON:100OHM,5%,1/8W,AA,TP,-	
R101	2001-001015	R-CARBON:9.1KOHM,5%,1/8W,AA,TP,-		R704	2001-000281	R-CARBON:100OHM,5%,1/8W,AA,TP,-	
R102	2001-000660	R-CARBON:33KOHM,5%,1/8W,AA,TP,-		R705	2001-000780	R-CARBON:470OHM,5%,1/8W,AA,TP,-	
R103	2003-001035	R-METAL OXIDE(S):27ohm,0.05,2W,AF,TP,3.9x10mm		R706	2001-000290	R-CARBON:10KOHM,5%,1/8W,AA,TP,-	
R107	2001-000281	R-CARBON:100OHM,5%,1/8W,AA,TP,-		R707	2001-000290	R-CARBON:10KOHM,5%,1/8W,AA,TP,-	
R119	2001-000331	R-CARBON:12KOHM,5%,1/8W,AA,TP,-		R708	2001-000780	R-CARBON:470OHM,5%,1/8W,AA,TP,-	
R203	2001-000281	R-CARBON:100OHM,5%,1/8W,AA,TP,-		R709	2003-000458	R-METAL OXIDE(S):100ohm,5%,2W,AF,TP,4x12mm	
R204	2001-000281	R-CARBON:100OHM,5%,1/8W,AA,TP,-		R710	2001-000281	R-CARBON:100OHM,5%,1/8W,AA,TP,-	
R205	2001-000221	R-CARBON:1.2KOHM,5%,1/8W,AA,TP,-		R711	2001-000969	R-CARBON:75OHM,5%,1/8W,AA,TP,-	
R206	2001-000429	R-CARBON:1KOHM,5%,1/8W,AA,TP,-		R712	2001-000281	R-CARBON:100OHM,5%,1/8W,AA,TP,-	
R207	2001-000281	R-CARBON:100OHM,5%,1/8W,AA,TP,-		R713	2001-000938	R-CARBON:68OHM,5%,1/8W,AA,TP,-	
R208	2001-000281	R-CARBON:100OHM,5%,1/8W,AA,TP,-		R719	2001-000281	R-CARBON:100OHM,5%,1/8W,AA,TP,-	
R209	2001-000281	R-CARBON:100OHM,5%,1/8W,AA,TP,-		R720	2001-000591	R-CARBON:3.3KOHM,5%,1/8W,AA,TP,-	
R210	2001-000832	R-CARBON:510OHM,5%,1/8W,AA,TP,-		R721	2001-000633	R-CARBON:30KOHM,5%,1/8W,AA,TP,-	
R211	2001-000645	R-CARBON:330KOHM,5%,1/8W,AA,TP,-		R723	2001-000290	R-CARBON:10KOHM,5%,1/8W,AA,TP,-	
R212	2001-000273	R-CARBON:100KOHM,5%,1/8W,AA,TP,-		R725	2001-000969	R-CARBON:75OHM,5%,1/8W,AA,TP,-	
R213	2001-001146	R-CARBON(S):4.7OHM,5%,1/2W,AA,TP,-		R726	2001-000969	R-CARBON:75OHM,5%,1/8W,AA,TP,-	
R215	2001-000008	R-CARBON:15KOHM,5%,1/8W,AA,TP,-		R728	2001-000429	R-CARBON:1KOHM,5%,1/8W,AA,TP,-	
R216	2001-000786	R-CARBON:47KOHM,5%,1/8W,AA,TP,-		R729	2001-000786	R-CARBON:47KOHM,5%,1/8W,AA,TP,-	
R217	2001-000397	R-CARBON:180KOHM,5%,1/8W,AA,TP,-		R730	2001-000786	R-CARBON:47KOHM,5%,1/8W,AA,TP,-	
R218	2004-001914	R-METAL:39Kohm,2%,1/8W,AA,TP,1.8x3.5mm		R800A	2002-001013	R-COMPOSITION:4.7Mohm,10%,1/2W,AA,TP,3.7x9mm	
R219	2001-000016	R-CARBON(S):10HM,5%,1/2W,AA,TP,-		R801	2002-001011	R-COMPOSITION:3.3Mohm,10%,1/2W,AA,TP,3.7x9mm	
R220	2001-000429	R-CARBON:1KOHM,5%,1/8W,AA,TP,-		R803	1404-000180	THERMISTOR-PTC:14ohm,20%,290V,25A,-,ST	
R221	2001-000429	R-CARBON:1KOHM,5%,1/8W,AA,TP,-		R804	2009-001012	R-METAL PLATE:0.27ohm,10%,5W,CJ,TP,5x14x18mm	
R222	2001-000429	R-CARBON:1KOHM,5%,1/8W,AA,TP,-		R805	2003-000462	R-METAL OXIDE(S):10Kohm,5%,2W,AA,TP,4x12mm	
R223	2001-000429	R-CARBON:1KOHM,5%,1/8W,AA,TP,-		R806	2003-000462	R-METAL OXIDE(S):10Kohm,5%,2W,AA,TP,4x12mm	
R224	2001-000009	R-CARBON:20KOHM,5%,1/8W,AA,TP,-		R807	2003-000462	R-METAL OXIDE(S):10Kohm,5%,2W,AA,TP,4x12mm	
R225	2001-000633	R-CARBON:30KOHM,5%,1/8W,AA,TP,-		R808	2006-000295	R-CEMENT:11ohm,5%,5W,CB,TP,9x13x25mm	
R228	2001-000800	R-CARBON:5.1KOHM,5%,1/8W,AA,TP,-		R809	2001-001096	R-CARBON(S):2.2OHM,5%,1/2W,AA,TP,-	
R230	2001-000281	R-CARBON:100OHM,5%,1/8W,AA,TP,-		R810	2003-002007	R-METAL OXIDE(S):4.7Kohm,5%,2W,AF,TP,3.9x10mm	
R233	2001-000449	R-CARBON:2.2KOHM,5%,1/8W,AA,TP,-		R812	1404-001045	THERMISTOR-NTC:4.7ohm,15%,2900K,35.0mW,TP	
R234	2001-000252	R-CARBON:1.6KOHM,5%,1/8W,AA,TP,-		R813	2001-001045	R-CARBON(S):1.2KOHM,5%,1/2W,AA,TP,-	
R237	2001-000563	R-CARBON:27KOHM,5%,1/8W,AA,TP,-		R814	2001-001097	R-CARBON(S):2.4KOHM,5%,1/2W,AA,TP,-	
R243	2001-000429	R-CARBON:1KOHM,5%,1/8W,AA,TP,-		R816	2001-001117	R-CARBON(S):2KOHM,5%,1/2W,AA,TP,-	
R244	2001-000429	R-CARBON:1KOHM,5%,1/8W,AA,TP,-		R819	2003-000532	R-METAL OXIDE(S):18ohm,5%,2W,AF,TP,4x12mm	
R247	2001-000490	R-CARBON:200OHM,5%,1/8W,AA,TP,-		R822	2001-001088	R-CARBON(S):1KOHM,5%,1/2W,AA,TP,-	
R248	2001-000793	R-CARBON:47OHM,5%,1/8W,AA,TP,-		R823	2001-000786	R-CARBON:47KOHM,5%,1/8W,AA,TP,-	
R249	2001-000857	R-CARBON:560OHM,5%,1/8W,AA,TP,-		R825	2001-001131	R-CARBON(S):33KOHM,5%,1/2W,AA,TP,-	
R250	2001-000832	R-CARBON:510OHM,5%,1/8W,AA,TP,-		R827	2003-001091	R-METAL OXIDE(S):10ohm,5%,2W,AF,TP,4x12mm	
R252	2001-000429	R-CARBON:1KOHM,5%,1/8W,AA,TP,-		R831	2003-000512	R-METAL OXIDE(S):15Kohm,5%,3W,AA,TP,6x16mm	
R301	2001-000472	R-CARBON:2.7KOHM,5%,1/8W,AA,TP,-		R833	2006-000309	R-CEMENT:22ohm,5%,5W,CB,TP,9x13x25mm	
R302	2001-000016	R-CARBON(S):10HM,5%,1/2W,AA,TP,-		R835	2003-000532	R-METAL OXIDE(S):18ohm,5%,2W,AF,TP,4x12mm	
R303	2008-000205	R-FUSIBLE(S):10ohm,5%,1/2W,AF,TP,2.5x6.5mm		R836	2001-001088	R-CARBON(S):1KOHM,5%,1/2W,AA,TP,-	
R304	2003-001032	R-METAL OXIDE(S):220ohm,5%,1W,AF,TP,2.5x6.5mm		R840	2001-001050	R-CARBON(S):1.5KOHM,5%,1/2W,AA,TP,-	

Electric Parts List

Loc. No.	Code No.	Description ; Specification	Remark	Loc. No.	Code No.	Description ; Specification	Remark
CM322	2202-000127	C-CERAMIC,MLC-AXIAL:10nF,+80-20%,25V,Y5V,TP,-7.5		CM606	2202-000127	C-CERAMIC,MLC-AXIAL:10nF,+80-20%,25V,Y5V,TP,-7.5	
CM323	2401-000603	C-AL:1uF,20%,50V,GP,TP,5x11,5		CM607	2202-002037	C-CERAMIC,MLC-AXIAL:100nF,80-20%,50V,Y5V,TP,2.2x3.	
CM324	2401-000603	C-AL:1uF,20%,50V,GP,TP,5x11,5		CM623	2202-000127	C-CERAMIC,MLC-AXIAL:10nF,+80-20%,25V,Y5V,TP,-7.5	
CM325	2401-000426	C-AL:10uF,20%,16V,GP,TP,3.5x5,5		CM624	2202-000162	C-CERAMIC,MLC-AXIAL:0.15nF,5%,50V,SL,TP,3.5X1.9MM,-	
CM326	2202-002037	C-CERAMIC,MLC-AXIAL:100nF,80-20%,50V,Y5V,TP,2.2x3.		CM625	2202-000162	C-CERAMIC,MLC-AXIAL:0.15nF,5%,50V,SL,TP,3.5X1.9MM,-	
CM327	2401-001363	C-AL:470uF,20%,16V,GP,TP,10x12.5,5		CM626	2202-000162	C-CERAMIC,MLC-AXIAL:0.15nF,5%,50V,SL,TP,3.5X1.9MM,-	
CM328	2401-002235	C-AL:10uF,20%,16V,GP,TP,5x11mm,5mm		CM627	2202-000162	C-CERAMIC,MLC-AXIAL:0.15nF,5%,50V,SL,TP,3.5X1.9MM,-	
CM329	2202-002037	C-CERAMIC,MLC-AXIAL:100nF,80-20%,50V,Y5V,TP,2.2x3.		CM628	2202-000807	C-CERAMIC,MLC-AXIAL:22nF,+80-20%,25V,Y5V,TP,3.5x19	
CM330	2401-002144	C-AL:47uF,20%,16V,GP,TP,5x11,5		CM629	2202-000807	C-CERAMIC,MLC-AXIAL:22nF,+80-20%,25V,Y5V,TP,3.5x19	
CM331	2401-002144	C-AL:47uF,20%,16V,GP,TP,5x11,5		CM630	2401-002291	C-AL:47uF,20%,16V,GP,TP,6.3x5,5	
CM332	2202-002037	C-CERAMIC,MLC-AXIAL:100nF,80-20%,50V,Y5V,TP,2.2x3.		CM631	2202-002037	C-CERAMIC,MLC-AXIAL:100nF,80-20%,50V,Y5V,TP,2.2x3.	
CM333	2401-000603	C-AL:1uF,20%,50V,GP,TP,5x11,5		CM633	2202-000796	C-CERAMIC,MLC-AXIAL:1nF,10%,50V,Y5P,TP,3.5X1.9MM,-	
CM334	2202-000121	C-CERAMIC,MLC-AXIAL:100pF,10%,50V,Y5P,TP,1.9x3.5,-		CM634	2202-000791	C-CERAMIC,MLC-AXIAL:150pF,10%,50V,Y5P,TP,3.5x19,-	
CM335	2401-002235	C-AL:10uF,20%,16V,GP,TP,5x11mm,5mm		CM635	2202-000791	C-CERAMIC,MLC-AXIAL:150pF,10%,50V,Y5P,TP,3.5x19,-	
CM336	2401-001333	C-AL:470nF,20%,50V,GP,TP,5x11,5		CM636	2202-002037	C-CERAMIC,MLC-AXIAL:100nF,80-20%,50V,Y5V,TP,2.2x3.	
CM337	2202-000806	C-CERAMIC,MLC-AXIAL:220pF,10%,50V,Y5P,TP,3.5x19,-		CM637	2202-002037	C-CERAMIC,MLC-AXIAL:100nF,80-20%,50V,Y5V,TP,2.2x3.	
CM338	2202-000162	C-CERAMIC,MLC-AXIAL:0.15nF,5%,50V,SL,TP,3.5X1.9MM,-		CM638	2202-000127	C-CERAMIC,MLC-AXIAL:10nF,+80-20%,25V,Y5V,TP,-7.5	
CM339	2202-000862	C-CERAMIC,MLC-AXIAL:390pF,10%,50V,Y5P,TP,3.5x1.9,-		CM639	2401-000444	C-AL:10uF,20%,25V,GP,TP,5x5mm,5mm	
CM340	2401-000030	C-AL:22uF,20%,25V,GP,TP,5x11,5		CM642	2202-002037	C-CERAMIC,MLC-AXIAL:100nF,80-20%,50V,Y5V,TP,2.2x3.	
CM341	2202-000279	C-CERAMIC,MLC-AXIAL:47pF,5%,50V,SL,TP,3.5x19,-		CM657	2401-001537	C-AL:47uF,20%,25V,GP,TP,6.3x7mm,5mm	
CM343	2202-000127	C-CERAMIC,MLC-AXIAL:10nF,+80-20%,25V,Y5V,TP,-7.5		CM658	2202-000127	C-CERAMIC,MLC-AXIAL:10nF,+80-20%,25V,Y5V,TP,-7.5	
CM344	2202-000216	C-CERAMIC,MLC-AXIAL:0.27nF,5%,50V,SL,TP,3.5X1.9MM,-		CM659	2401-001537	C-AL:47uF,20%,25V,GP,TP,6.3x7mm,5mm	
CM345	2202-000127	C-CERAMIC,MLC-AXIAL:10nF,+80-20%,25V,Y5V,TP,-7.5		CM660	2202-000127	C-CERAMIC,MLC-AXIAL:10nF,+80-20%,25V,Y5V,TP,-7.5	
CM346	2202-000127	C-CERAMIC,MLC-AXIAL:10nF,+80-20%,25V,Y5V,TP,-7.5		CM666	2202-000243	C-CERAMIC,MLC-AXIAL:33pF,5%,50V,SL,TP,3.5x19,-	
CM347	2202-000127	C-CERAMIC,MLC-AXIAL:10nF,+80-20%,25V,Y5V,TP,-7.5		CM667	2301-000175	C-FILM,PEF:15nF,5%,50V,TP,7.1x3.5x13mm,5m	
CM348	2301-000356	C-FILM,PEF:47nF,5%,50V,TP,7.5x4.0x6.5,5mm		CM670	2401-001537	C-AL:47uF,20%,25V,GP,TP,6.3x7mm,5mm	
CM349	2401-000603	C-AL:1uF,20%,50V,GP,TP,5x11,5		CM671	2202-000127	C-CERAMIC,MLC-AXIAL:10nF,+80-20%,25V,Y5V,TP,-7.5	
CM350	2202-000127	C-CERAMIC,MLC-AXIAL:10nF,+80-20%,25V,Y5V,TP,-7.5		CM691	2202-002037	C-CERAMIC,MLC-AXIAL:100nF,80-20%,50V,Y5V,TP,2.2x3.	
CM351	2202-000145	C-CERAMIC,MLC-AXIAL:12nF,10%,50V,Y5P,TP,3.5X1.9MM,		CM701	2401-002009	C-AL:100uF,20%,16V,GP,TP,6.3x7,5	
CM353	2202-000127	C-CERAMIC,MLC-AXIAL:10nF,+80-20%,25V,Y5V,TP,-7.5		CM702	2202-002037	C-CERAMIC,MLC-AXIAL:100nF,80-20%,50V,Y5V,TP,2.2x3.	
CM356	2202-002037	C-CERAMIC,MLC-AXIAL:100nF,80-20%,50V,Y5V,TP,2.2x3.		CNM001	3711-002647	CONNECTOR-HEADER:BOX,8P,1R,2.5mm,STRAIGHT,SN	
CM371	2202-000127	C-CERAMIC,MLC-AXIAL:10nF,+80-20%,25V,Y5V,TP,-7.5		CNM01A	AA39-20040A	LEAD CONNECTOR-ASSY:-,67096-008,S,8P,300,1185#26	
CM405	2202-000127	C-CERAMIC,MLC-AXIAL:10nF,+80-20%,25V,Y5V,TP,-7.5		CNM05A	AA39-20032B	LEAD-CONNECTOR,ASSY:-,67096-012,S,12P,300,1007#26	
CM409	2202-000127	C-CERAMIC,MLC-AXIAL:10nF,+80-20%,25V,Y5V,TP,-7.5		CNM201	3711-003749	CONNECTOR-HEADER:BOX,8P,2R,2mm,STRAIGHT,SN	
CM410	2202-000127	C-CERAMIC,MLC-AXIAL:10nF,+80-20%,25V,Y5V,TP,-7.5		CNM202	3708-001165	CONNECTOR-FPC/FC/PC:6P,1.25mm,STRAIGHT,SN	
CM411	2202-000127	C-CERAMIC,MLC-AXIAL:10nF,+80-20%,25V,Y5V,TP,-7.5		CNM20A	3809-001048	CABLE-FLAT:30V,80C,110mm,6P,1.25mm,UL2896	
CM412	2202-000127	C-CERAMIC,MLC-AXIAL:10nF,+80-20%,25V,Y5V,TP,-7.5		CNM301	3708-000395	CONNECTOR-FPC/FC/PC:8P,1.25mm,STRAIGHT,SN	
CM414	2401-002144	C-AL:47uF,20%,16V,GP,TP,5x11,5		CNM501	3708-001053	CONNECTOR-FPC/FC/PC:7P,1.25mm,STRAIGHT,SN	
CM415	2202-002037	C-CERAMIC,MLC-AXIAL:100nF,80-20%,50V,Y5V,TP,2.2x3.		CNM502	3710-000404	CONNECTOR-SOCKET:2P,2R,2.0mm,-	
CM416	2202-000127	C-CERAMIC,MLC-AXIAL:10nF,+80-20%,25V,Y5V,TP,-7.5		CNM601	3710-000405	CONNECTOR-SOCKET:2P,2R,2.5mm,-	
CM417	2401-000603	C-AL:1uF,20%,50V,GP,TP,5x11,5		CNM605	3711-003641	CONNECTOR-HEADER:BOX,12P,1R,2.5mm,STRAIGHT,SN	
CM425	2202-000127	C-CERAMIC,MLC-AXIAL:10nF,+80-20%,25V,Y5V,TP,-7.5		CNM606	3711-001061	CONNECTOR-HEADER:BOX,6P,1R,2mm,ANGLE,SN	
CM426	2202-000222	C-CERAMIC,MLC-AXIAL:3.3nF,20%,16V,Y5P,TP,-7.5		DM1103	0402-000132	DIODE-RECTIFIER:1N4004,400V,1A,DO-41,TP	
CM428	2202-002037	C-CERAMIC,MLC-AXIAL:100nF,80-20%,50V,Y5V,TP,2.2x3.		DM1106	0401-000005	DIODE-SWITCHING:1N4148,75V,300mA,DO-35,TP	
CM431	2202-000205	C-CERAMIC,MLC-AXIAL:22pF,5%,50V,SL,TP,1.9x3.5,-		DM601	0401-000005	DIODE-SWITCHING:1N4148,75V,300mA,DO-35,TP	
CM432	2202-000205	C-CERAMIC,MLC-AXIAL:22pF,5%,50V,SL,TP,1.9x3.5,-		DM602	0401-000005	DIODE-SWITCHING:1N4148,75V,300mA,DO-35,TP	
CM501	2305-000427	C-FILM,MPEF:47nF,5%,100V,TP,7.5x12.5x3.5,5		DM606	0402-000132	DIODE-RECTIFIER:1N4004,400V,1A,DO-41,TP	
CM570	2301-000383	C-FILM,PEF:10nF,5%,50V,TP,6x7x3.2mm,5mm		DM607	0402-000132	DIODE-RECTIFIER:1N4004,400V,1A,DO-41,TP	
CM571	2301-000175	C-FILM,PEF:15nF,5%,50V,TP,7.1x3.5x13mm,5mm		DM608	0401-000005	DIODE-SWITCHING:1N4148,75V,300mA,DO-35,TP	
CM572	2401-001537	C-AL:47uF,20%,25V,GP,TP,6.3x7mm,5mm		DM609	0401-000005	DIODE-SWITCHING:1N4148,75V,300mA,DO-35,TP	
CM573	2301-000301	C-FILM,PEF:6.8nF,5%,50V,TP,6.5X5.5X3.0X5		DM610	0402-000132	DIODE-RECTIFIER:1N4004,400V,1A,DO-41,TP	
CM574	2301-000445	C-FILM,PEF:4.7nF,5%,50V,TP,5.5x7x3mm,5mm		DM611	0402-000132	DIODE-RECTIFIER:1N4004,400V,1A,DO-41,TP	
CM575	2305-000289	C-FILM,MPEF:220nF,5%,63V,TP,-5mm		DM615	0401-000005	DIODE-SWITCHING:1N4148,75V,300mA,DO-35,TP	
CM576	2401-000922	C-AL:22uF,20%,16V,GP,TP,5x5,5		DM616	0401-000005	DIODE-SWITCHING:1N4148,75V,300mA,DO-35,TP	
CM577	2401-002299	C-AL:4.7uF,20%,50V,GP,TP,5x7,5		DM701	0401-000005	DIODE-SWITCHING:1N4148,75V,300mA,DO-35,TP	
CM578	2202-002037	C-CERAMIC,MLC-AXIAL:100nF,80-20%,50V,Y5V,TP,2.2x3.		DM705	0401-000005	DIODE-SWITCHING:1N4148,75V,300mA,DO-35,TP	
CM580	2202-002037	C-CERAMIC,MLC-AXIAL:100nF,80-20%,50V,Y5V,TP,2.2x3.		FLM501	AA26-10006C	TRANS-IF:-,7ML,BIAS,-,7mm,3100pF,70KHz	
CM581	2401-002144	C-AL:47uF,20%,16V,GP,TP,5x11,5		HOLDER	AA61-20267A	HOLDER-LED:-,SMV-267V,POM,-,-	
CM582	2401-002069	C-AL:33uF,20%,16V,GP,TP,6.3x5,5		HOLDER	AA61-20268A	HOLDER-TR:-,SMV-267V,POM,-,-	
CM583	2301-000192	C-FILM,PEF:1nF,5%,50V,TP,5.3x10mm,5mm		HOLDER	AA61-20269A	HOLDER-PHOTO:-,SMV-267V,POM,-,-	
CM584	2301-000204	C-FILM,PEF:2.7nF,5%,50V,TP,7.4x3.9x13mm,5		△ ICM01	1203-000298	IC-POS.FIXED REG.:7809,TO-220,3P,-,PLASTIC,8.65/	
CM586	2401-000426	C-AL:10uF,20%,16V,GP,TP,3.5x5,5		△ ICM201	1201-000229	IC-OP AMP:324,DIP,14P,300MIL,QUAD,100V/m	
CM587	2301-000383	C-FILM,PEF:10nF,5%,50V,TP,6x7x3.2mm,5mm		△ ICM301	1204-001352	IC-SIGNAL PROCESSOR:SS11507M,QFP,80P,-,PLASTIC,7V,	
CM588	2401-000598	C-AL:1uF,20%,50V,GP,TP,4x7,5		△ ICM302	1209-001171	IC-DELAY LINE:SS23378M,SOP,14P,225MIL,PLASTI	
CM589	2401-002009	C-AL:100uF,20%,16V,GP,TP,6.3x7,5		△ ICM401	1201-001115	IC-PREAMP:7411,DIP,24P,400MIL,-,100mV/V,	
CM590	2301-000301	C-FILM,PEF:6.8nF,5%,50V,TP,6.5X5.5X3.0X5		△ ICM601	AA13-30019K	IC-MCU:-,HD6433977R804F-00,8BIT,OFF,T	
CM591	2301-000301	C-FILM,PEF:6.8nF,5%,50V,TP,6.5X5.5X3.0X5		△ ICM602	1202-000001	IC-VOLTAGE COMP:7533,TO-92,3P,-,SINGLE,-,-,PLA	
CM592	2301-000314	C-FILM,PEF:8.2nF,5%,50V,TP,6.5x3.0x5.5mm,		△ ICM603	1003-001090	IC-MOTOR DRIVER:LB1643,SIP,10P,-,SINGLE,1.6A,S	
CM594	2401-002299	C-AL:4.7uF,20%,50V,GP,TP,5x7,5		△ LDM601	AA91-60265A	ASSY-HOLDER,LED:-,-,POM,BLK,M-260,SMV-267V	
CM595	2401-000426	C-AL:10uF,20%,16V,GP,TP,3.5x5,5		LDM602	AA91-60278A	ASSY-HOLDER,LED:-,ABS,VOLK,M30,TVCR ALL	
CM596	2401-000598	C-AL:1uF,20%,50V,GP,TP,4x7,5		LED	0601-000495	LED-IR,ROUND,3mm,150mW,6V,950nm,BK	
CM597	2202-000127	C-CERAMIC,MLC-AXIAL:10nF,+80-20%,25V,Y5V,TP,-7.5		LM301	2701-000002	INDUCTOR-AXIAL:100uH,10%,4.2x9.8mm	
CM601	2202-000295	C-CERAMIC,MLC-AXIAL:68pF,5%,50V,SL,TP,3.5x19,-		LM302	2701-000207	INDUCTOR-AXIAL:56uH,5%,2.5x3.4mm	
CM602	2202-002037	C-CERAMIC,MLC-AXIAL:100nF,80-20%,50V,Y5V,TP,2.2x3.		LM304	2701-000207	INDUCTOR-AXIAL:56uH,5%,2.5x3.4mm	
CM603	2401-001250	C-AL:4.7uF,20%,35V,GP,TP,4x5,5		LM305	2701-000207	INDUCTOR-AXIAL:56uH,5%,2.5x3.4mm	
CM604	2202-000127	C-CERAMIC,MLC-AXIAL:10nF,+80-20%,25V,Y5V,TP,-7.5		LM307	2701-000118	INDUCTOR-AXIAL:120uH,10%,2.5x3.4mm	
CM605	2202-000127	C-CERAMIC,MLC-AXIAL:10nF,+80-20%,25V,Y5V,TP,-7.5		LM401	2701-000002	INDUCTOR-AXIAL:100uH,10%,4.2x9.8mm	

Loc. No.	Code No.	Description ; Specification	Remark	Loc. No.	Code No.	Description ; Specification	Remark
LM571	2702-000120	INDUCTOR-RADIAL:15mH,5%,6.2x7.4mm		RM317	2001-000221	R-CARBON:1.2KOHM,5%,1/8W,AA,TP-	
LM572	2701-000002	INDUCTOR-AXIAL:100uH,10%,4.2x9.8mm		RM318	2001-000241	R-CARBON:1.5KOHM,5%,1/8W,AA,TP-	
LM573	2701-000002	INDUCTOR-AXIAL:100uH,10%,4.2x9.8mm		RM319	2001-000734	R-CARBON:4.7KOHM,5%,1/8W,AA,TP-	
LM574	2701-000180	INDUCTOR-AXIAL:33uH,5%,2.5x3.4mm		RM321	2001-001026	R-CARBON:910OHM,5%,1/8W,AA,TP-	
LM602	2701-000002	INDUCTOR-AXIAL:100uH,10%,4.2x9.8mm		RM323	2001-000221	R-CARBON:1.2KOHM,5%,1/8W,AA,TP-	
LM603	2701-000002	INDUCTOR-AXIAL:100uH,10%,4.2x9.8mm		RM324	2001-000005	R-CARBON:390OHM,5%,1/8W,AA,TP-	
LM604	2701-000002	INDUCTOR-AXIAL:100uH,10%,4.2x9.8mm		RM325	2001-000005	R-CARBON:390OHM,5%,1/8W,AA,TP-	
PHOTO	0604-000188	PHOTO-INTERRUPTER:TR,-, -,DIP-4,TR		RM326	2001-000577	R-CARBON:2KOHM,5%,1/8W,AA,TP-	
PTM601	AA91-60267A	ASSY-HOLDER,PHOTO:-, -,POM WHT,M-260,SMV-267V		RM327	2001-000613	R-CARBON:3.9KOHM,5%,1/8W,AA,TP-	
PTM602	AA91-60267A	ASSY-HOLDER,PHOTO:-, -,POM WHT,M-260,SMV-267V		RM328	2001-000995	R-CARBON:820OHM,5%,1/8W,AA,TP-	
QM103	0501-000316	TR-SMALL SIGNAL:KSA928A-Y,PNP,1W,TO-92L,-,160-		RM329	2001-000577	R-CARBON:2KOHM,5%,1/8W,AA,TP-	
QM104	0504-000118	TR-DIGITAL:KSR1003,NPN,300mW,22K-22K,TO-9		RM332	2001-000554	R-CARBON:270OHM,5%,1/8W,AA,TP-	
QM105	0501-000362	TR-SMALL SIGNAL:KSA2328A-Y,NPN,1W,TO-92L,TP,16		RM333	2001-000660	R-CARBON:33KOHM,5%,1/8W,AA,TP-	
QM301	0501-000398	TR-SMALL SIGNAL:KSC945,NPN,250mW,TO-92,TP,120-		RM334	2001-000660	R-CARBON:33KOHM,5%,1/8W,AA,TP-	
QM302	0504-000119	TR-DIGITAL:KSR1004,NPN,300mW,47K-47K,TO-9		RM335	2001-000613	R-CARBON:3.9KOHM,5%,1/8W,AA,TP-	
QM303	0501-000303	TR-SMALL SIGNAL:KSA733,PNP,250mW,TO-92,TP,120-		RM336	2001-000890	R-CARBON:6.8KOHM,5%,1/8W,AA,TP-	
QM304	0501-000303	TR-SMALL SIGNAL:KSA733,PNP,250mW,TO-92,TP,120-		RM337	2001-000472	R-CARBON:2.7KOHM,5%,1/8W,AA,TP-	
QM305	0501-000398	TR-SMALL SIGNAL:KSC945,NPN,250mW,TO-92,TP,120-		RM338	2001-000734	R-CARBON:4.7KOHM,5%,1/8W,AA,TP-	
QM306	0501-000398	TR-SMALL SIGNAL:KSC945,NPN,250mW,TO-92,TP,120-		RM339	2001-000429	R-CARBON:1KOHM,5%,1/8W,AA,TP-	
QM308	0501-000303	TR-SMALL SIGNAL:KSA733,PNP,250mW,TO-92,TP,120-		RM340	2001-000449	R-CARBON:2.2KOHM,5%,1/8W,AA,TP-	
QM309	0501-000303	TR-SMALL SIGNAL:KSA733,PNP,250mW,TO-92,TP,120-		RM341	2001-000302	R-CARBON:100OHM,5%,1/8W,AA,TP-	
QM310	0501-000303	TR-SMALL SIGNAL:KSA733,PNP,250mW,TO-92,TP,120-		RM342	2001-000331	R-CARBON:12KOHM,5%,1/8W,AA,TP-	
QM570	0504-000119	TR-DIGITAL:KSR1004,NPN,300mW,47K-47K,TO-9		RM343	2001-001154	R-CARBON(S):5.1KOHM,5%,1/2W,AA,TP-	
QM571	0501-000231	TR-SMALL SIGNAL:2SD1468SQ,NPN,300mW,TO-92S,TP,		RM344	2001-000302	R-CARBON:100OHM,5%,1/8W,AA,TP-	
QM572	0501-000231	TR-SMALL SIGNAL:2SD1468SQ,NPN,300mW,TO-92S,TP,		RM360	2001-000734	R-CARBON:4.7KOHM,5%,1/8W,AA,TP-	
QM573	0501-000303	TR-SMALL SIGNAL:KSA733,PNP,250mW,TO-92,TP,120-		RM402	2001-000302	R-CARBON:100OHM,5%,1/8W,AA,TP-	
QM574	0501-000010	TR-SMALL SIGNAL:KSC1008,NPN,800mW,TO-92,TP,120		RM403	2001-000522	R-CARBON:22KOHM,5%,1/8W,AA,TP-	
QM575	0501-000398	TR-SMALL SIGNAL:KSC945,NPN,250mW,TO-92,TP,120-		RM405	2001-000241	R-CARBON:1.5KOHM,5%,1/8W,AA,TP-	
QM602	0501-000398	TR-SMALL SIGNAL:KSC945,NPN,250mW,TO-92,TP,120-		RM406	2001-000864	R-CARBON:56KOHM,5%,1/8W,AA,TP-	
QM603	0501-000398	TR-SMALL SIGNAL:KSC945,NPN,250mW,TO-92,TP,120-		RM407	2001-000273	R-CARBON:100KOHM,5%,1/8W,AA,TP-	
QM605	0501-000303	TR-SMALL SIGNAL:KSA733,PNP,250mW,TO-92,TP,120-		RM408	2001-000005	R-CARBON:390OHM,5%,1/8W,AA,TP-	
QM608	0501-000398	TR-SMALL SIGNAL:KSC945,NPN,250mW,TO-92,TP,120-		RM409	2001-000005	R-CARBON:390OHM,5%,1/8W,AA,TP-	
QM701	0504-000118	TR-DIGITAL:KSR1003,NPN,300mW,22K-22K,TO-9		RM567	2004-001989	R-METAL:620ohm,5%,1/8W,AA,TP,1.8x3.2mm	
QM702	0504-000118	TR-DIGITAL:KSR1003,NPN,300mW,22K-22K,TO-9		RM568	2001-000734	R-CARBON:4.7KOHM,5%,1/8W,AA,TP-	
QM703	0504-000118	TR-DIGITAL:KSR1003,NPN,300mW,22K-22K,TO-9		RM569	2001-000007	R-CARBON:3KOHM,5%,1/8W,AA,TP-	
REM701	AA59-60001U	MODULE-REMOCON:-,ORC-50VF/SR-12V,38KHz,940nm,		RM570	2001-000006	R-CARBON:2.4KOHM,5%,1/8W,AA,TP-	
RM106	2001-000429	R-CARBON:1KOHM,5%,1/8W,AA,TP-		RM571	2001-000405	R-CARBON:180OHM,5%,1/8W,AA,TP-	
RM107	2001-000241	R-CARBON:1.5KOHM,5%,1/8W,AA,TP-		RM572	2001-000780	R-CARBON:470OHM,5%,1/8W,AA,TP-	
RM109	2001-001107	R-CARBON(S):220ohm,5%,1/2W,AA,TP,2.4x6.4mm		RM573	2001-000258	R-CARBON:1.8KOHM,5%,1/8W,AA,TP-	
RM111	2001-000449	R-CARBON:2.2KOHM,5%,1/8W,AA,TP-		RM574	2001-000449	R-CARBON:2.2KOHM,5%,1/8W,AA,TP-	
RM201	2001-000429	R-CARBON:1KOHM,5%,1/8W,AA,TP-		RM575	2001-000449	R-CARBON:2.2KOHM,5%,1/8W,AA,TP-	
RM202	2001-000812	R-CARBON:5.6KOHM,5%,1/8W,AA,TP-		RM576	2001-000458	R-CARBON:2.2OHM,5%,1/8W,AA,TP-	
RM203	2001-000864	R-CARBON:56KOHM,5%,1/8W,AA,TP-		RM577	2001-000290	R-CARBON:10KOHM,5%,1/8W,AA,TP-	
RM204	2001-000864	R-CARBON:56KOHM,5%,1/8W,AA,TP-		RM578	2001-000522	R-CARBON:22KOHM,5%,1/8W,AA,TP-	
RM205	2001-000362	R-CARBON:150OHM,5%,1/8W,AA,TP-		RM579	2001-000702	R-CARBON:39KOHM,5%,1/8W,AA,TP-	
RM206	2001-000362	R-CARBON:150OHM,5%,1/8W,AA,TP-		RM580	2001-000947	R-CARBON:7.5KOHM,5%,1/8W,AA,TP-	
RM207	2001-000290	R-CARBON:10KOHM,5%,1/8W,AA,TP-		RM581	2001-000454	R-CARBON:2.2MOHM,5%,1/8W,AA,TP-	
RM208	2001-000429	R-CARBON:1KOHM,5%,1/8W,AA,TP-		RM582	2001-000290	R-CARBON:10KOHM,5%,1/8W,AA,TP-	
RM209	2004-001185	R-METAL:680Kohm,5%,1/8W,AA,TP,1.8x3.2m		RM585	2001-000241	R-CARBON:1.5KOHM,5%,1/8W,AA,TP-	
RM210	2001-000429	R-CARBON:1KOHM,5%,1/8W,AA,TP-		RM586	2001-000660	R-CARBON:33KOHM,5%,1/8W,AA,TP-	
RM217	2001-000786	R-CARBON:47KOHM,5%,1/8W,AA,TP-		RM587	2001-000362	R-CARBON:150OHM,5%,1/8W,AA,TP-	
RM218	2001-000273	R-CARBON:100KOHM,5%,1/8W,AA,TP-		RM588	2001-000645	R-CARBON:330KOHM,5%,1/8W,AA,TP-	
RM219	2001-000290	R-CARBON:10KOHM,5%,1/8W,AA,TP-		RM589	2001-000331	R-CARBON:12KOHM,5%,1/8W,AA,TP-	
RM220	2001-000331	R-CARBON:12KOHM,5%,1/8W,AA,TP-		RM591	2001-000812	R-CARBON:5.6KOHM,5%,1/8W,AA,TP-	
RM221	2001-000290	R-CARBON:10KOHM,5%,1/8W,AA,TP-		RM594	2001-000221	R-CARBON:1.2KOHM,5%,1/8W,AA,TP-	
RM222	2001-000429	R-CARBON:1KOHM,5%,1/8W,AA,TP-		RM597	2001-000786	R-CARBON:47KOHM,5%,1/8W,AA,TP-	
RM223	2001-000429	R-CARBON:1KOHM,5%,1/8W,AA,TP-		RM598	2001-000734	R-CARBON:4.7KOHM,5%,1/8W,AA,TP-	
RM224	2001-000864	R-CARBON:56KOHM,5%,1/8W,AA,TP-		RM599	2001-000734	R-CARBON:4.7KOHM,5%,1/8W,AA,TP-	
RM225	2001-001031	R-CARBON:91KOHM,5%,1/8W,AA,TP-		RM601	2001-000429	R-CARBON:1KOHM,5%,1/8W,AA,TP-	
RM226	2001-000864	R-CARBON:56KOHM,5%,1/8W,AA,TP-		RM604	2001-000429	R-CARBON:1KOHM,5%,1/8W,AA,TP-	
RM227	2001-000221	R-CARBON:1.2KOHM,5%,1/8W,AA,TP-		RM605	2001-000281	R-CARBON:100OHM,5%,1/8W,AA,TP-	
RM229	2001-000633	R-CARBON:30KOHM,5%,1/8W,AA,TP-		RM606	2001-000429	R-CARBON:1KOHM,5%,1/8W,AA,TP-	
RM230	2001-000633	R-CARBON:30KOHM,5%,1/8W,AA,TP-		RM607	2001-000010	R-CARBON:68KOHM,5%,1/8W,AA,TP-	
RM231	2004-001089	R-METAL:560Kohm,5%,1/8W,AA,TP,1.8x3.2m		RM608	2001-000832	R-CARBON:510OHM,5%,1/8W,AA,TP-	
RM303	2001-000003	R-CARBON:330OHM,5%,1/8W,AA,TP-		RM610	2001-000660	R-CARBON:33KOHM,5%,1/8W,AA,TP-	
RM305	2001-000258	R-CARBON:1.8KOHM,5%,1/8W,AA,TP-		RM612	2001-000435	R-CARBON:1MOHM,5%,1/8W,AA,TP-	
RM306	2001-000258	R-CARBON:1.8KOHM,5%,1/8W,AA,TP-		RM615	2001-000290	R-CARBON:10KOHM,5%,1/8W,AA,TP-	
RM307	2001-000977	R-CARBON:8.2KOHM,5%,1/8W,AA,TP-		RM616	2001-000290	R-CARBON:10KOHM,5%,1/8W,AA,TP-	
RM308	2001-000429	R-CARBON:1KOHM,5%,1/8W,AA,TP-		RM617	2001-000429	R-CARBON:1KOHM,5%,1/8W,AA,TP-	
RM309	2001-000472	R-CARBON:2.7KOHM,5%,1/8W,AA,TP-		RM618	2001-000429	R-CARBON:1KOHM,5%,1/8W,AA,TP-	
RM310	2001-000449	R-CARBON:2.2KOHM,5%,1/8W,AA,TP-		RM619	2001-000734	R-CARBON:4.7KOHM,5%,1/8W,AA,TP-	
RM311	2001-000319	R-CARBON:120KOHM,5%,1/8W,AA,TP-		RM621	2001-000429	R-CARBON:1KOHM,5%,1/8W,AA,TP-	
RM312	2001-000005	R-CARBON:390OHM,5%,1/8W,AA,TP-		RM628	2001-000832	R-CARBON:510OHM,5%,1/8W,AA,TP-	
RM313	2001-000449	R-CARBON:2.2KOHM,5%,1/8W,AA,TP-		RM629	2001-000508	R-CARBON:220KOHM,5%,1/8W,AA,TP-	
RM314	2001-000331	R-CARBON:12KOHM,5%,1/8W,AA,TP-		RM630	2001-000508	R-CARBON:220KOHM,5%,1/8W,AA,TP-	
RM315	2001-000969	R-CARBON:75OHM,5%,1/8W,AA,TP-		RM631	2001-000832	R-CARBON:510OHM,5%,1/8W,AA,TP-	
RM316	2001-000037	R-CARBON(S):330OHM,5%,1/2W,AA,TP-		RM632	2001-000508	R-CARBON:220KOHM,5%,1/8W,AA,TP-	

9. Block Diagrams

9-1 SCV11F Video Block Diagram

9-1-1 Notes

The TV's 1st and 2nd tuners (and VCR module) are "multi-system." compatible: IC201 (TDA8374) is the video, chroma, and deflection (VCD) IC .

9-1-1(A) TAPE PLAYBACK (REGARDLESS OF ORIGINAL RECORDING SYSTEM)

If the output PB signal of micom pin 6 is high, the PB signal outputs from module deck 1, passes through IC 702 pins 1 and 8 and out to another VCR . The output signal of IC701 pin 1 (pin 15) outputs from IC201 pin 17 (RBG OUT).

9-1-1(B) VIEWING NORMAL CHANNEL WHILE RECORDING A SCRAMBLED CHANNEL:

The output CVBS (Composite Video Signal) of the 2nd IF outputs to pin 8 when the micom's pin 7 V/T/H (VCR tuner high) is high (IC702 pin 3). The decoded signal goes to IC701 pin 2, where it is fed to IC 701 pin 4 (high output of micom's pin 8— AV/Tuner), and out to VCR pin 3 (module deck) for recording.

9-1-1(C) VIEWING A SCRAMBLED CHANNEL WHILE RECORDING AN UNSCRAMBLED CHANNEL.

The output CVBS of the 2nd IF is fed from IC801 pin 5 to IC702 pin 4 (low output of micom pin 8—AV/tuner). Then it goes to the module deck pin 3 for recording.

The scrambled signal (CVBS) is fed to IC702 pin 6 through the 1st IF, and then to IC702 pin 8 (micom's pin 7, V/T/H registers low). Then it goes to the decoder input. The descrambled signal goes to IC701 pins 2 and 15 (PH high output of micom's pin 6), and then to IC201 pin 17, where it outputs as RGB.

9-1-1(D) SYNCHRONOUS RECORDING:

The viewer sees the signal from the 1st tuner , while the signal from the second tuner is recorded. Audio processing for the French system type is shown in the table.

9-1 SCV11A,B Video Block Diagram (Continued)

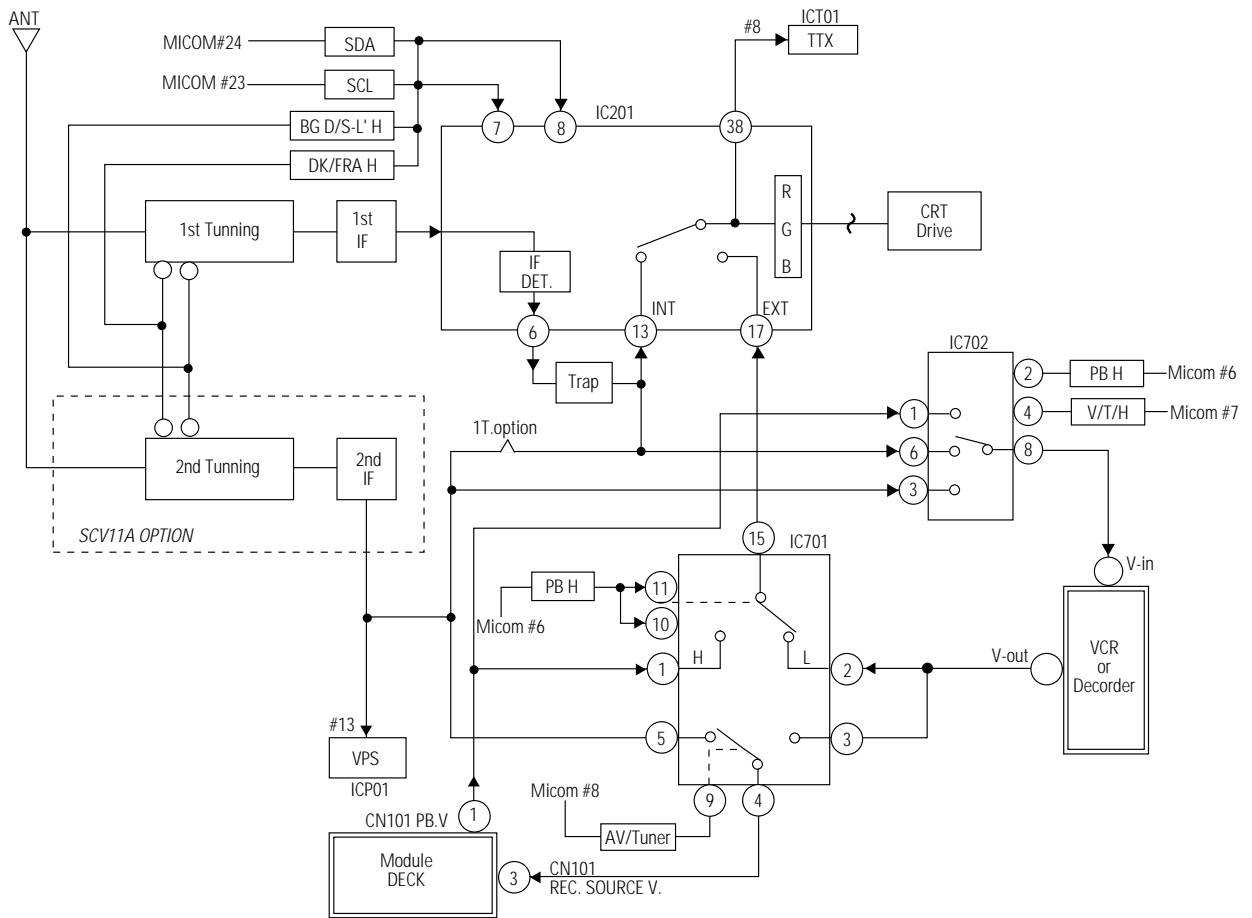

Micom Pin Function

PIN NO.	PIN NAME	FUNCTION												
6	PB H	High Output : Playback signal is monitored. The PB signal is output at scart.												
7	V/T/H	High Output : The second tuner signal is output at scart.												
8	AV/TUNER	High Output : AV signal is recorded. Low output : TUNER signal is recorded.												
23, 24	SDA, SCL BG/S-L' H DK/FRA H	<table border="1" style="margin-left: auto; margin-right: auto;"> <thead> <tr> <th>S \ Port</th> <th>BG/S-L</th> <th>DK/FRA</th> </tr> </thead> <tbody> <tr> <td>PAL/SEC</td> <td>L</td> <td>L</td> </tr> <tr> <td>FRANCE-L</td> <td>L</td> <td>H</td> </tr> <tr> <td>FRANCE-L'</td> <td>H</td> <td>L</td> </tr> </tbody> </table> <p>Ⓐ C. SYSTEM : PAL/SEC ARE AUTO mode, and France is SECAM mode.</p>	S \ Port	BG/S-L	DK/FRA	PAL/SEC	L	L	FRANCE-L	L	H	FRANCE-L'	H	L
S \ Port	BG/S-L	DK/FRA												
PAL/SEC	L	L												
FRANCE-L	L	H												
FRANCE-L'	H	L												
23,24	SDA,SCL	Extra control signals are all controlled by the I ² C bus. Select INT/EXT FRENCH system modulation												

9-1 SCV11F Audio Block Diagram (Continued)

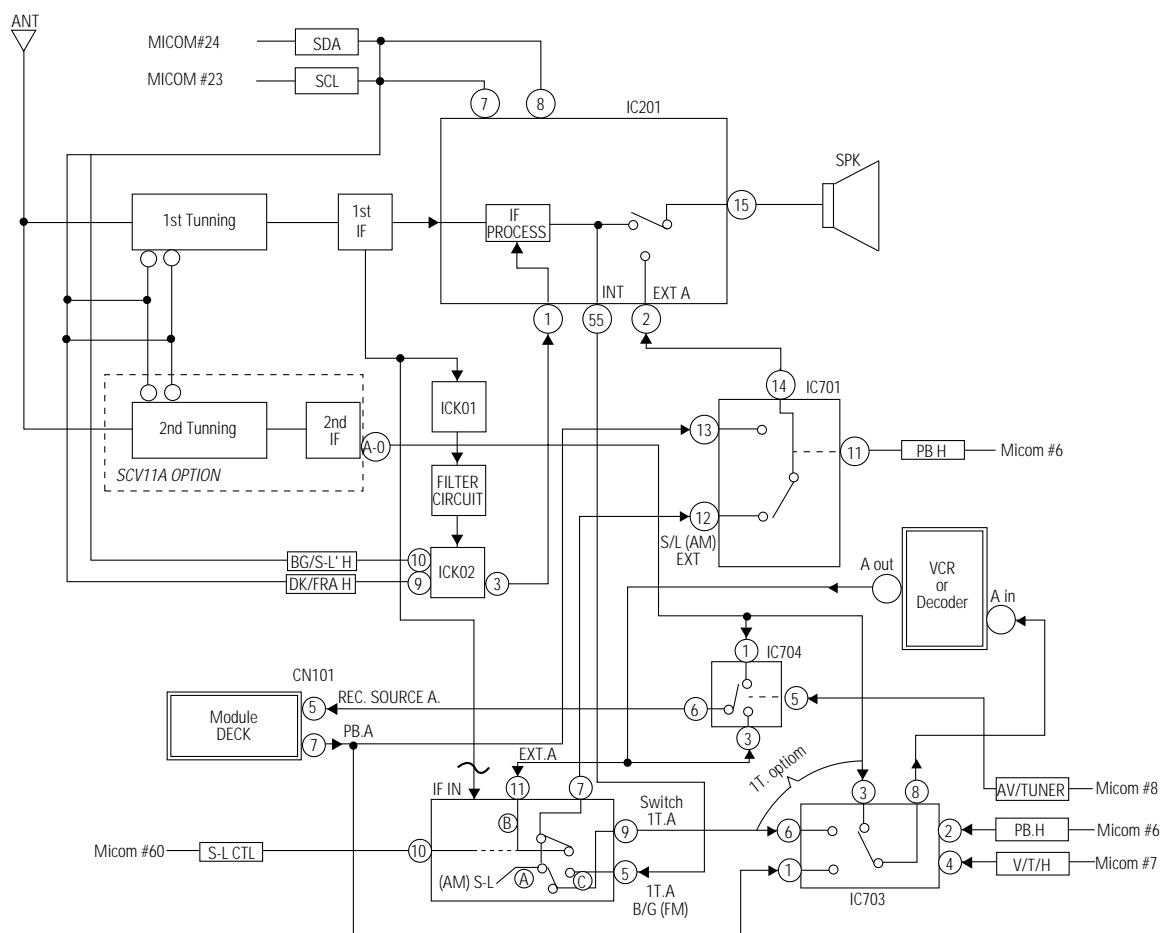

Micom Pin Function

PIN NO.	PIN NAME	FUNCTION															
6	PB H	High output : PB audio is monitored. The PB audio is output at scart.															
7	V/T/H	High output : The second tuner audio is output at a scart.															
8	AV/TUNER	High output : AV audio is recorded. Low output : TUNER audio is recorded.															
60	S-L CTL (a) :S-L(AM) (b) : B/G (FM) (c) :EXT	① 1.8 ~ 2.6V : In TV FM Mode, connect pin 7 to A and pin 9 to C. ② 4.1 ~ 4.9V : In TV AM Mode, connect pin 7 to A and pin 9 to A. ③ 6.4 ~ 7.2V : In AV-AM Mode, connect pin 7 to B and pin 9 to A. ④ More than 7.3V : In AV-FM Mode, connect pin 7 to B and pin 9 to C.															
23,24	SDA, SCL BG/S-L' H DK/FRA H	<table border="1" style="margin-left: auto; margin-right: auto;"> <thead> <tr> <th>Port \ S</th> <th>B/G</th> <th>D/K</th> </tr> </thead> <tbody> <tr> <td>AUTO</td> <td>H</td> <td>H</td> </tr> <tr> <td>BG (NT)</td> <td>H</td> <td>L(111)</td> </tr> <tr> <td>DK</td> <td>L</td> <td>H</td> </tr> <tr> <td>I</td> <td>L</td> <td>L</td> </tr> </tbody> </table> <p> (a) When system is output (111), mark with NT3.58 instead of B/G (b) Extra control signals are all controlled by the IC bus. </p>	Port \ S	B/G	D/K	AUTO	H	H	BG (NT)	H	L(111)	DK	L	H	I	L	L
Port \ S	B/G	D/K															
AUTO	H	H															
BG (NT)	H	L(111)															
DK	L	H															
I	L	L															

10. PCB Layout

10-1 Video Main

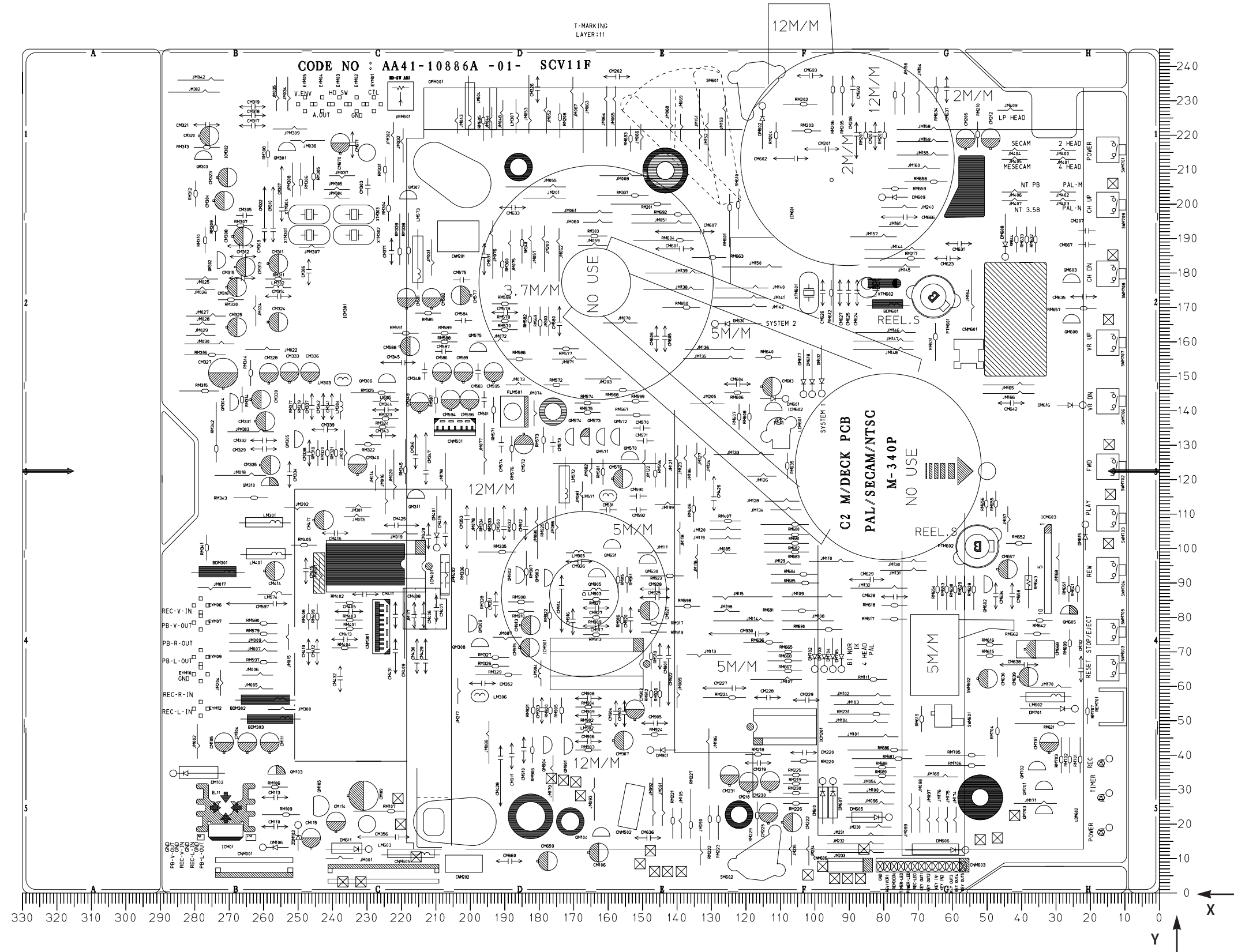

Loc. No.	X	Y	Loc. No.	X	Y
DIODE					
D102	238	209	DZ705	204	216
D205	156	116	DZ706	206	216
D209	222	140	DZ707	209	216
D401	124	169	DZ801	8	23
D402	120	169	DZ802	99	95
D403	85	194	DZ803	85	164
D404	81	190	DZ804	134	57
D405	73	180	DZ805	121	105
D407	153	101	DZ806	51	8
D801	78	12	DZ807	286	205
D802	71	25	DZ808	92	85
D803	62	12	DZ809	88	85
D804	84	9	DZ901	178	16
D805	81	51	DZ902	245	30
D806	66	62	DZ904	157	29
D807	69	75	DZ905	153	66
D808	81	116	DZ906	187	64
IC					
D809	61	107	IC201	205	145
D810	47	87	IC301	137	183
D811	81	112	IC601	254	59
D812	69	146	IC701	227	107
D813	51	155	IC702	218	106
D814	67	108	IC703	217	100
D815	134	20	IC704	239	116
D817	33	146	IC801	97	60
D818	12	158	IC804	144	60
D820	99	128	IC805	118	78
D821	94	85	IC806	114	144
D822	124	99	IC807	138	147
D829	143	46	IC811	144	104
D831	132	35	IC812	144	92
D832	135	35	IC901	230	52
D833	137	35	IC902	243	57
D834	146	46	IC903	251	31
D836	132	96	ICU101	293	171
D837	152	83	TRANSISTOR		
D850	132	120	Q201	232	186
D851	72	138	Q202	227	143
D901	155	12	Q203	165	101
D906	235	17	Q204	181	108
D908	217	79	Q207	167	133
D910	222	78	Q401	79	235
D912	197	27	Q402	147	209
D913	183	15	Q601	258	66
D914	202	27	Q701	170	223
D916	180	16	Q702	257	154
D919	238	15	Q703	264	174
D921	158	24	Q801	94	79
D922	172	77	Q802	102	100
DK01	178	118	Q803	128	104
DK02	181	118	Q804	135	115
DZ101	254	227	Q805	132	74
DZ201	262	77	Q806	140	40
DZ301	107	195	Q807	135	40
DZ302	127	190	Q901	172	17
DZ303	122	203	Q902	190	68
DZ304	126	200	Q903	170	194
DZ702	212	209	Q904	276	35
DZ704	258	126	QL03	236	151

10-2 TV Main

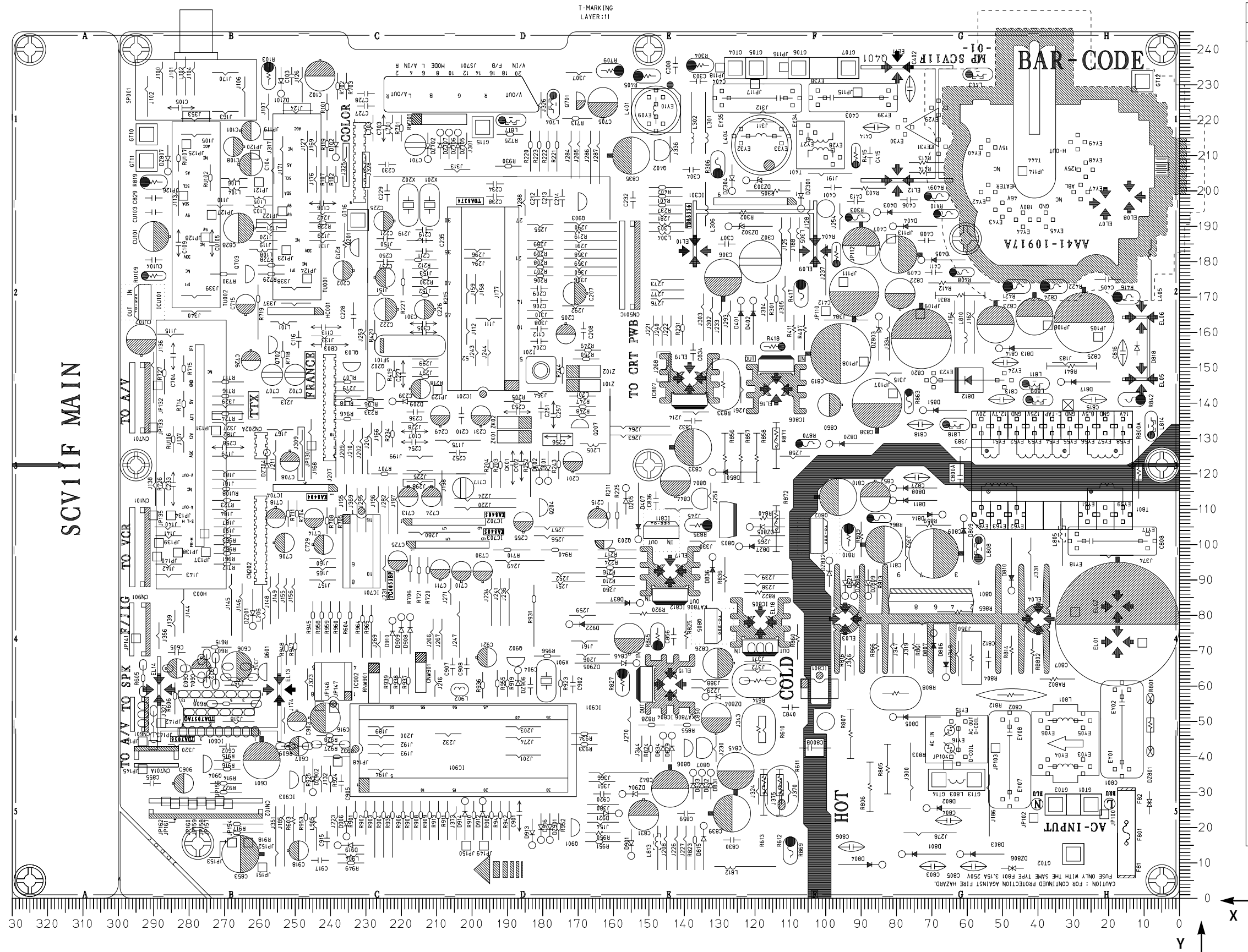

Loc. No.	X	Y	Loc. No.	X	Y	
DIODE						
D102	238	209	DZ707	209	216	
D205	156	116	DZ801	8	23	
D209	222	140	DZ802	99	95	
D401	124	169	DZ803	85	164	
D402	120	169	DZ804	134	57	
D403	85	194	DZ805	121	105	
D404	81	190	DZ806	51	8	
D405	73	180	DZ807	286	205	
D407	153	101	DZ808	92	85	
D801	78	12	DZ901	178	16	
D802	71	25	DZ902	245	30	
D803	62	12	DZ904	157	29	
D804	84	9	DZ905	153	66	
D805	81	51	DZ906	187	64	
D806	66	62	IC			
D807	69	75	IC201	205	145	
D808	81	116	IC301	137	183	
D809	61	107	IC601	254	59	
D810	47	87	IC701	227	107	
D811	81	112	IC702	218	106	
D812	69	146	IC703	217	100	
D813	51	155	IC704	239	116	
D814	67	108	IC801	97	60	
D815	134	20	IC804	144	60	
D817	33	146	IC805	118	78	
D818	12	158	IC806	114	144	
D820	99	128	IC807	138	147	
D821	94	85	IC811	144	104	
D827	124	99	IC812	144	92	
D829	143	46	IC901	230	52	
D831	132	35	IC902	243	57	
D832	135	35	IC903	251	31	
D833	137	35	ICU101	293	171	
D834	146	46	TRANSISTOR			
D836	132	96	Q201	232	186	
D837	152	83	Q202	227	143	
D850	132	120	Q203	165	101	
D901	155	12	Q204	181	108	
D906	235	17	Q207	167	133	
D908	217	79	Q401	79	235	
D909	220	79	Q402	147	209	
D910	222	78	Q601	258	66	
D912	197	27	Q701	170	223	
D913	183	15	Q702	257	154	
D914	202	27	Q703	264	174	
D916	180	16	Q801	94	79	
D919	238	15	Q802	102	100	
D921	158	24	Q803	128	104	
D922	172	77	Q804	135	115	
DK01	178	118	Q805	132	74	
DK02	181	118	Q806	140	40	
DZ101	254	227	Q807	135	40	
DZ201	262	77	Q901	172	17	
DZ301	107	195	Q902	190	68	
DZ302	127	190	Q903	170	194	
DZ303	122	203	Q904	276	35	
DZ304	126	200	OL03	236	151	
DZ702	212	209				
DZ704	258	126				
DZ705	204	216				
DZ706	206	216				

10-3 PCB-CRT

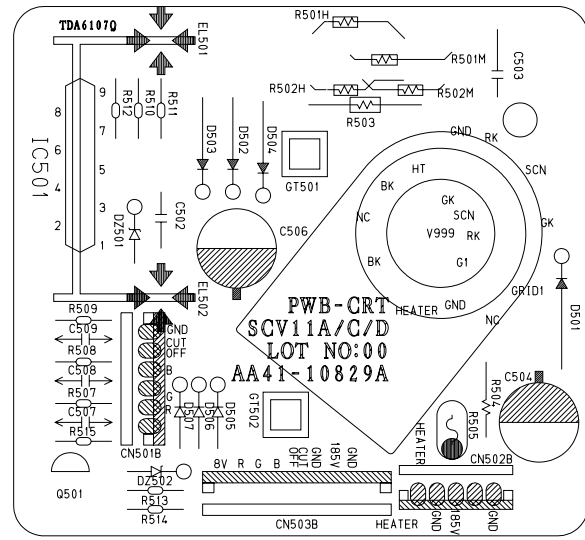

10-4 PCB-TTX

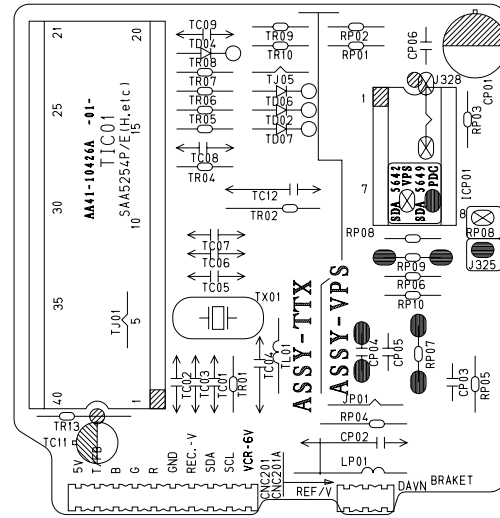

10-4 PCB-I/F

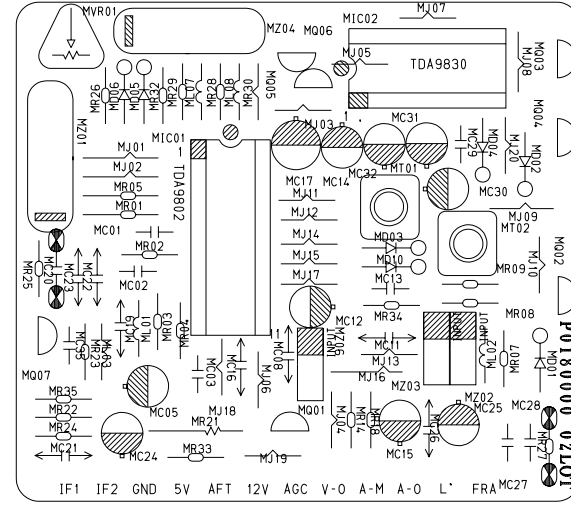

10-6 PWB-A/V

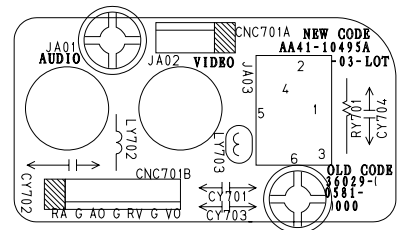
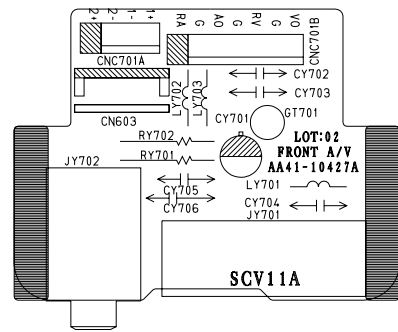

10-7 PCB-MASTER

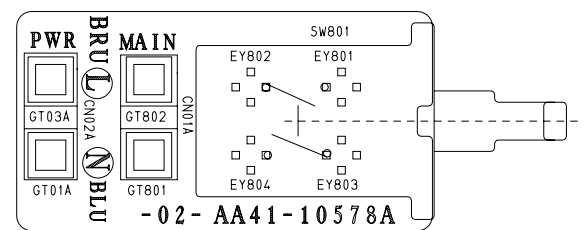

10-8 PCB-COLOR

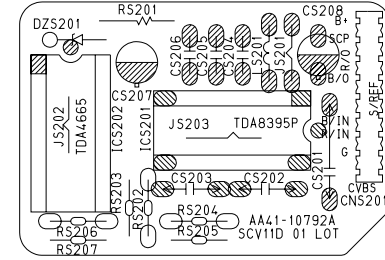

10-9 PCB-SECL/SIF

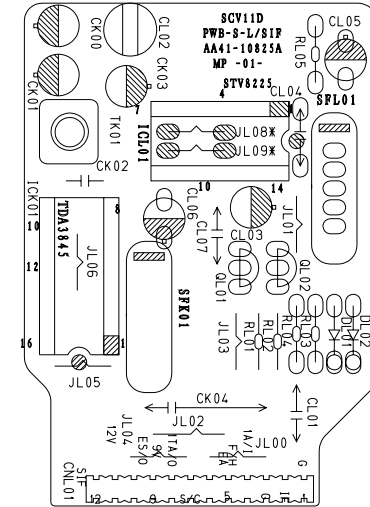

11. Wiring Diagram

11-1 SCV11F Wiring Diagram

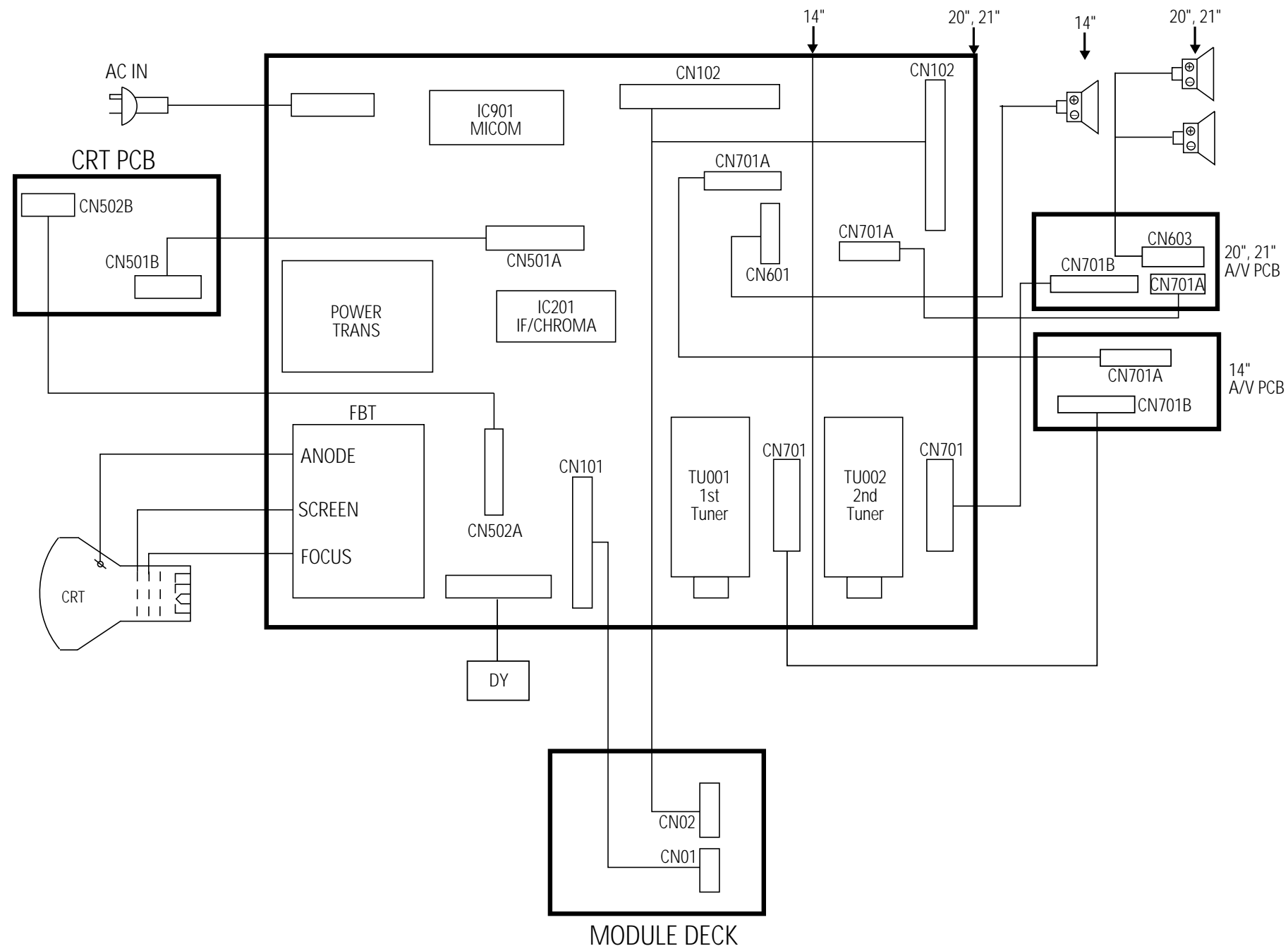

11-2 SCV11F Wiring Diagram

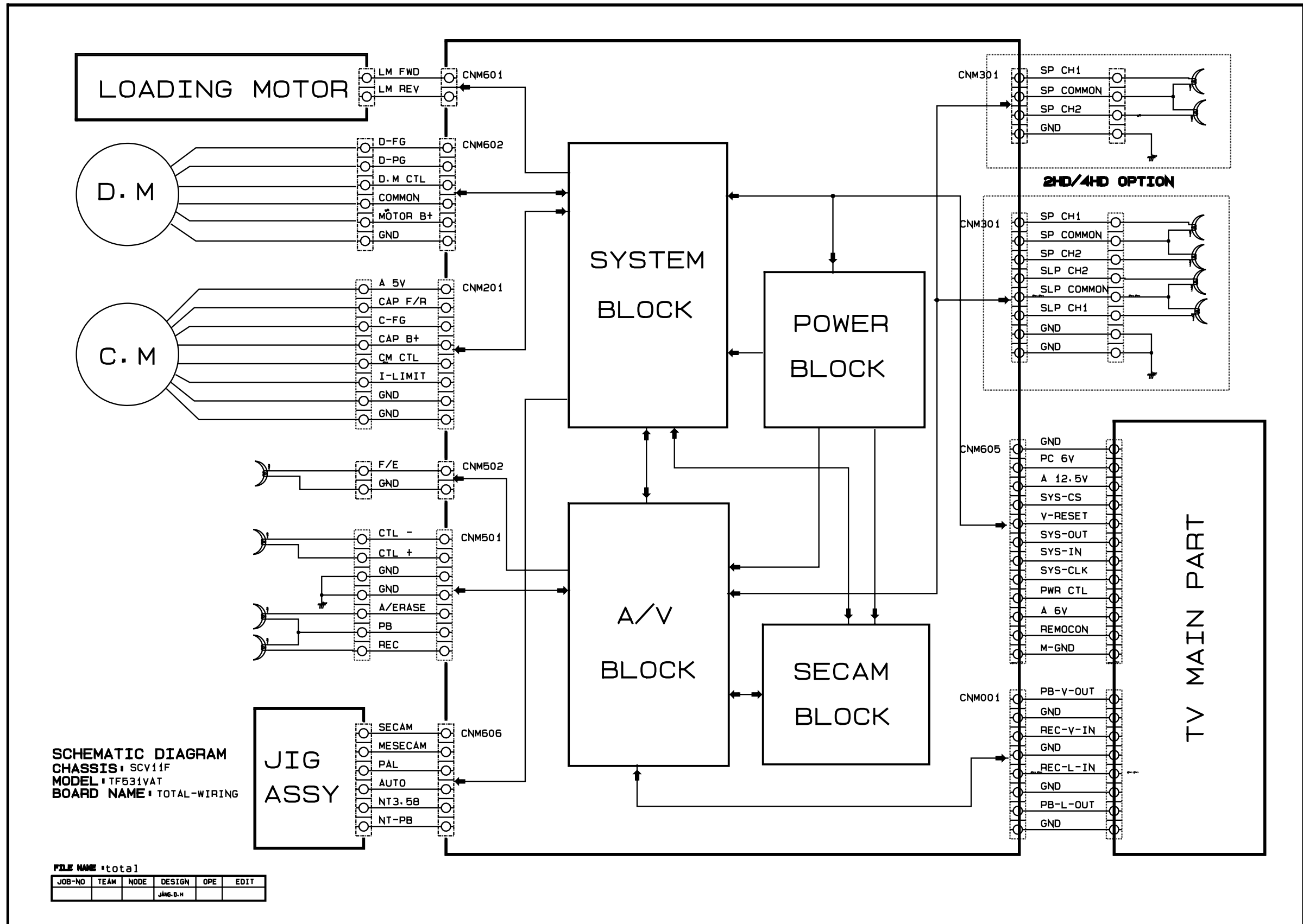

12. Schematic Diagrams

12-1 VCR (SECAM-BLOCK)

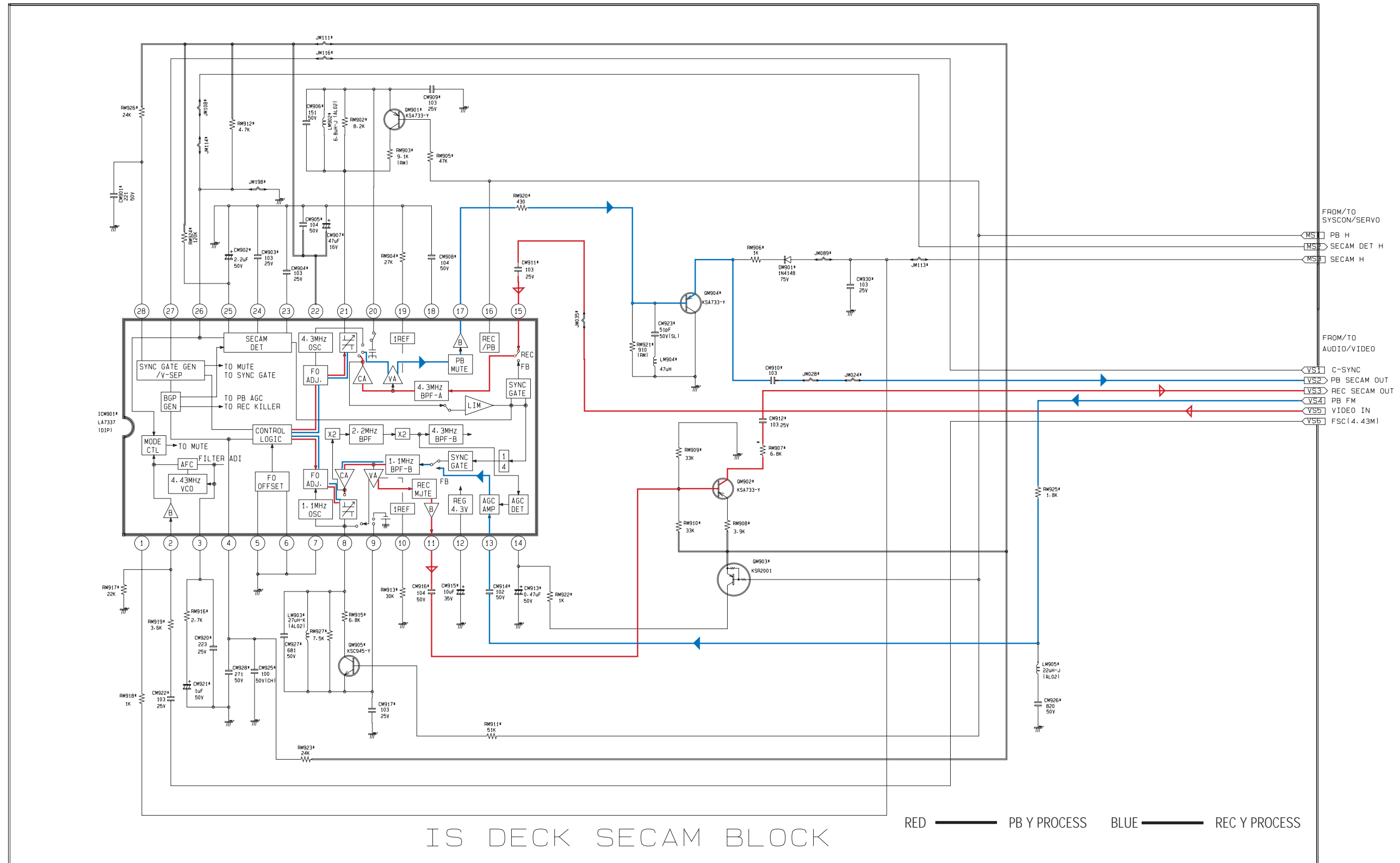

12-2 VCR (SYSTEM BLOCK)

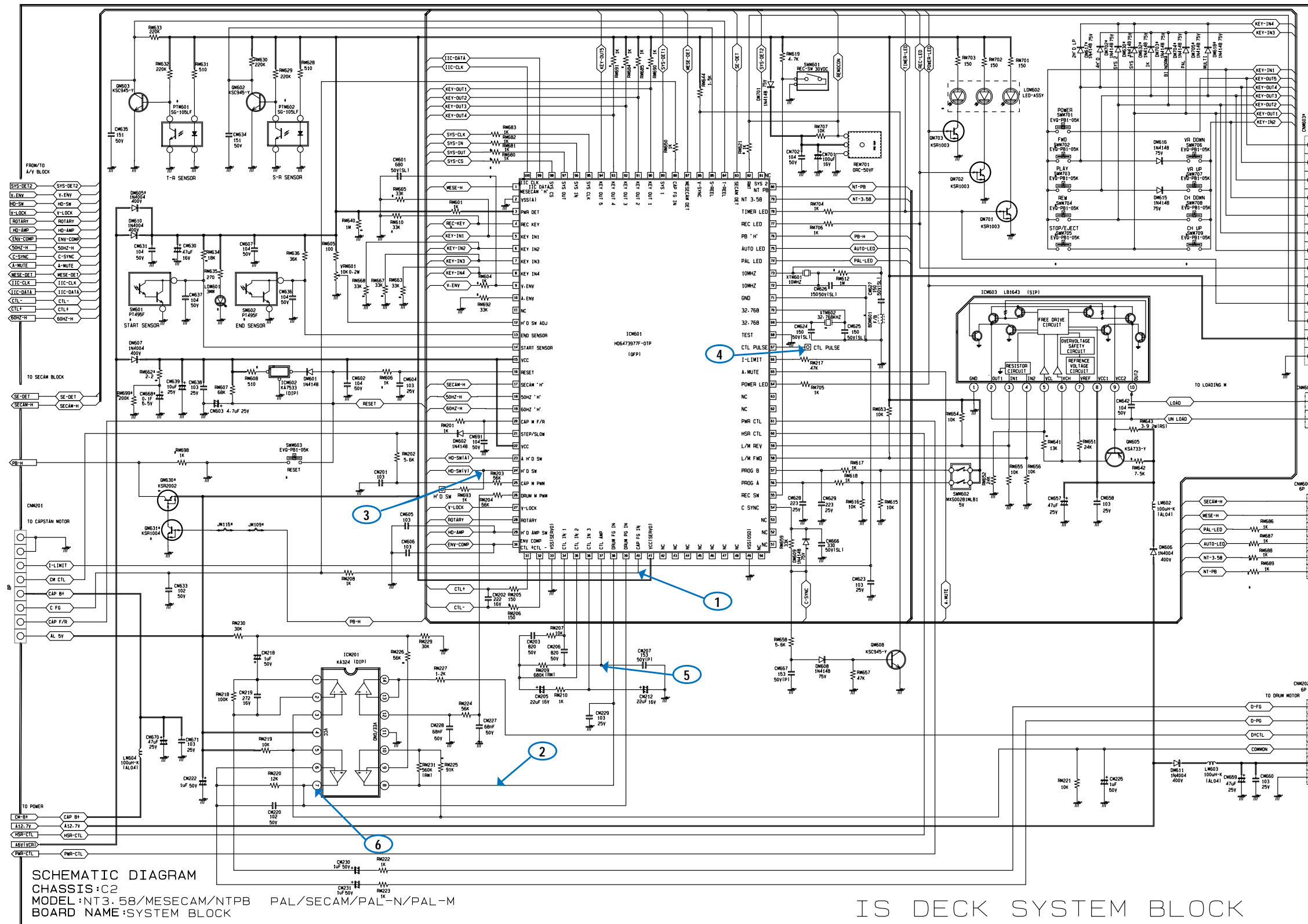

12-3 VCR (A/V BLOCK)

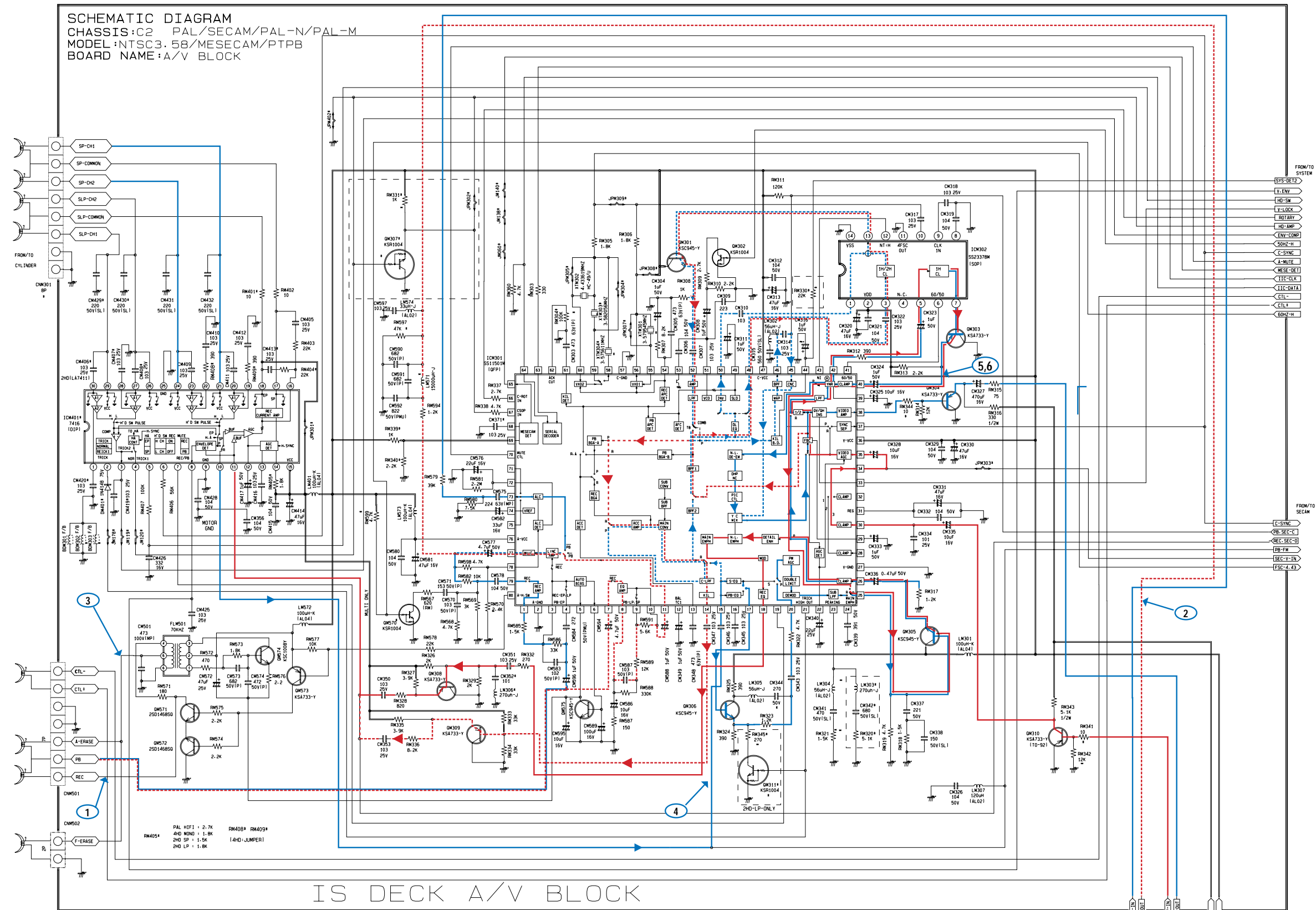

RED ——— REC Y PROCESS BLUE ——— PB Y PROCESS BLUE ——— REC AUDIO
 - - - - - REC C PROCESS - - - - - PB C PROCESS - - - - - PB AUDIO

12-4 VCR (POWER BLOCK)

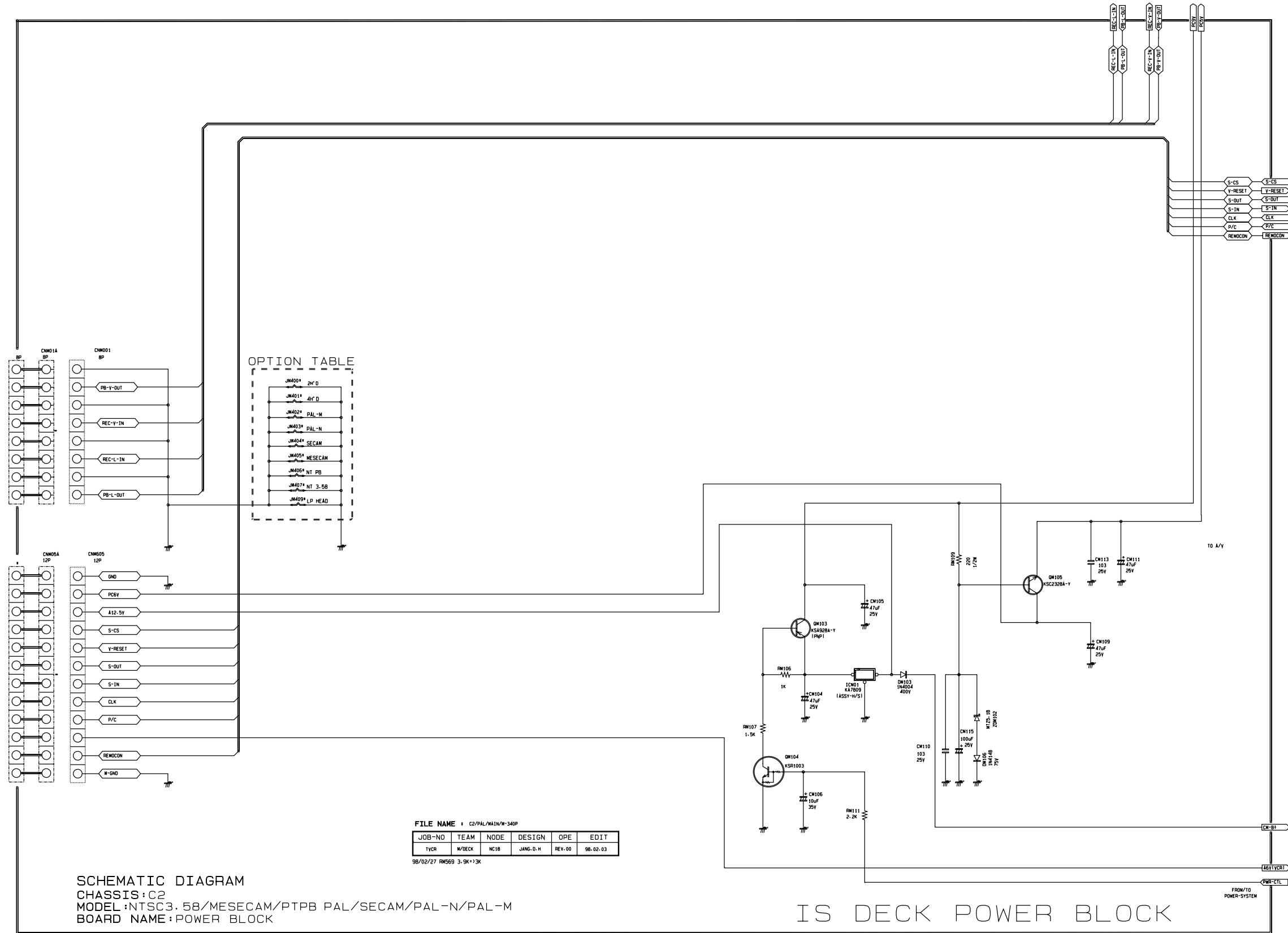

12-5 TV (1/4)

SCHEMATIC DIAGRAM
 CHASSIS: SCV11F SCV11F
 MODEL: TF531VAT1S/XEF
 BOARD NAME: A/V SWITCHING
 1' ST IF/CHROMA/2' nd TUNER

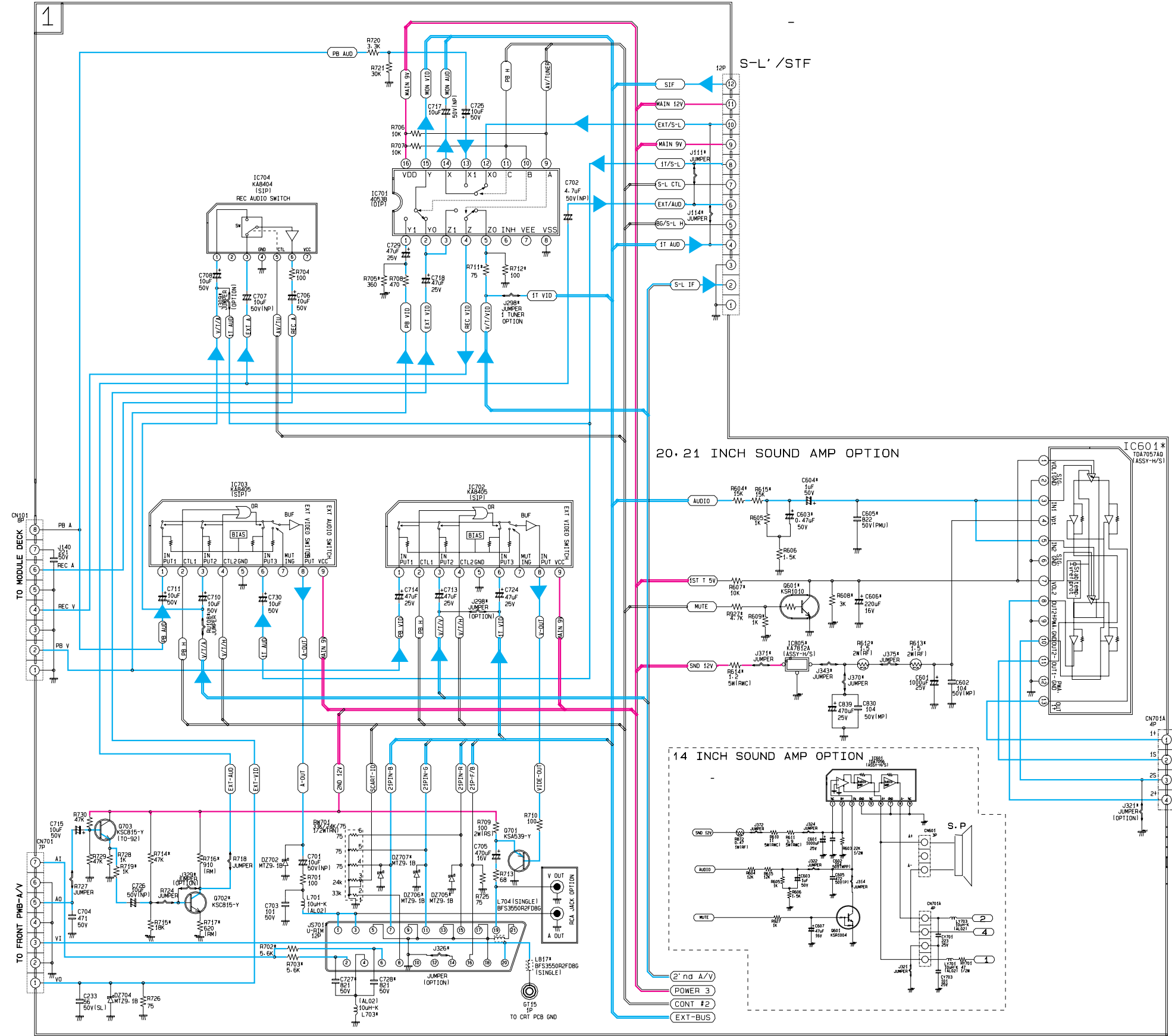

RED — POWER LINE
 BLUE — SIGNAL LINE

12-6 TV (2/4)

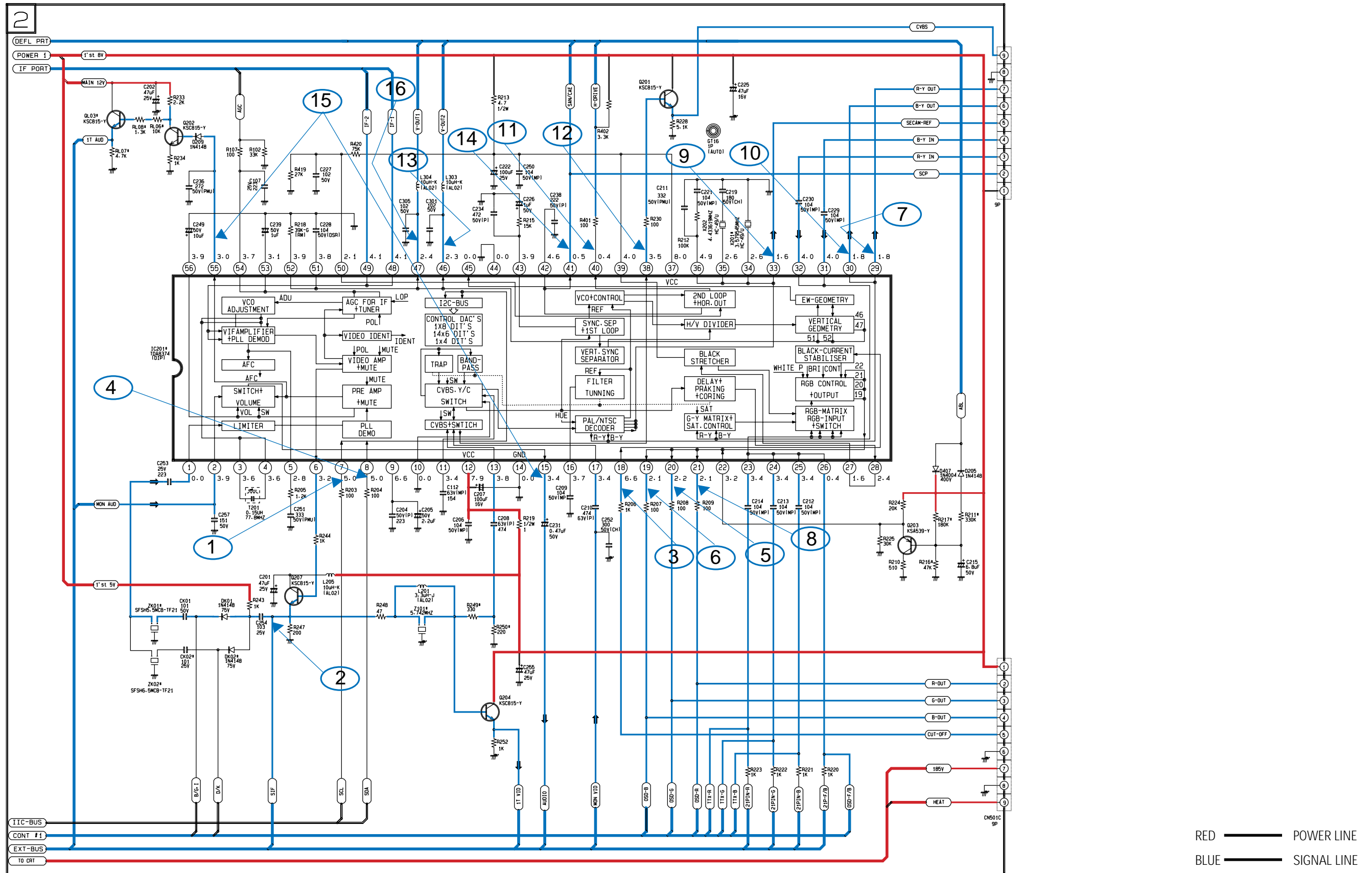

12-7 TV (3/4)

SCHEMATIC DIAGRAM
 CHASSIS : SCV11F
 MODEL : TF531VAT1S/XEF
 BOARD NAME : MICOM/EEPROM/SMPS
 HORIZ/VERT/FBT

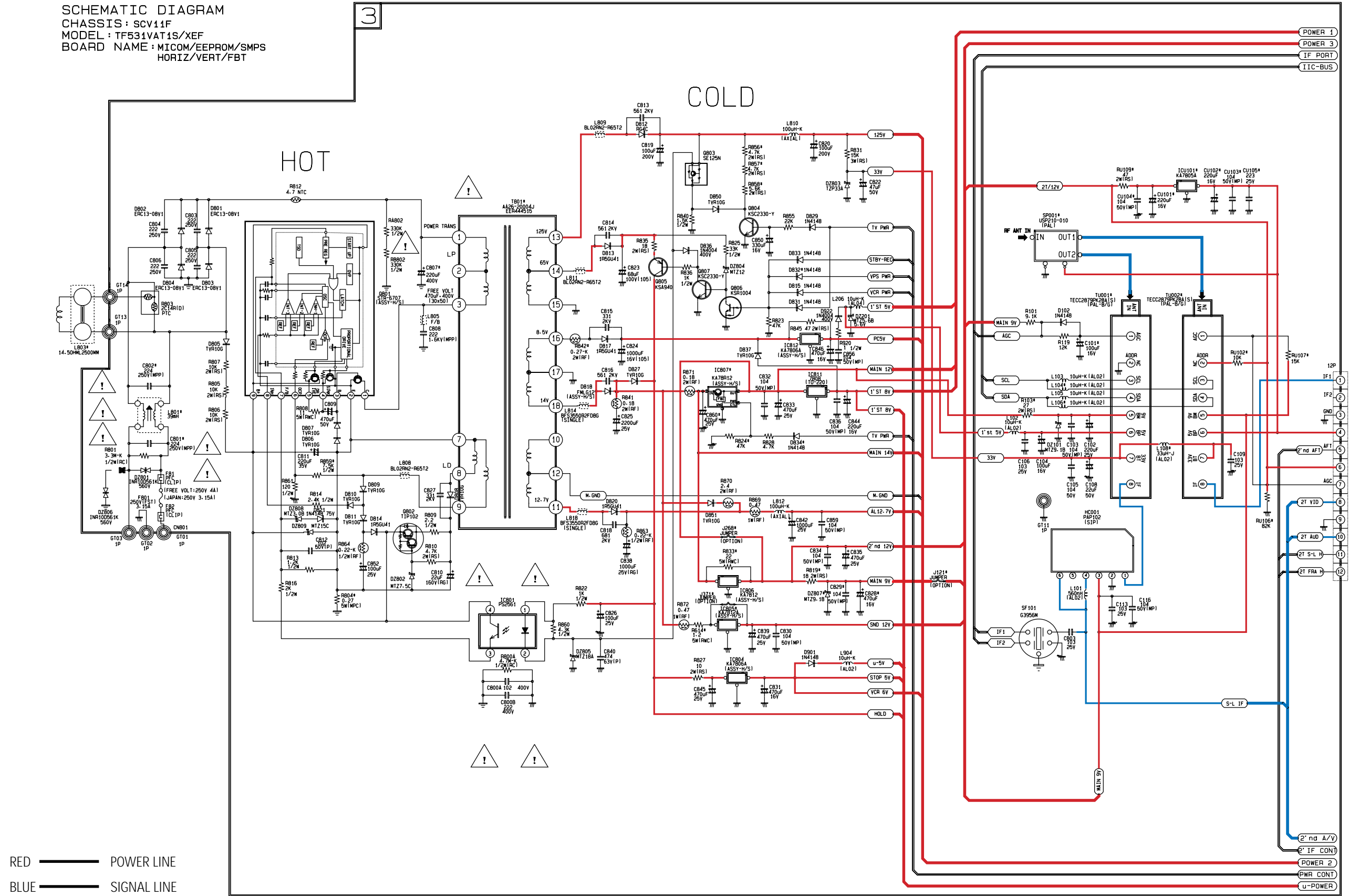

12-8 TV (4/4)

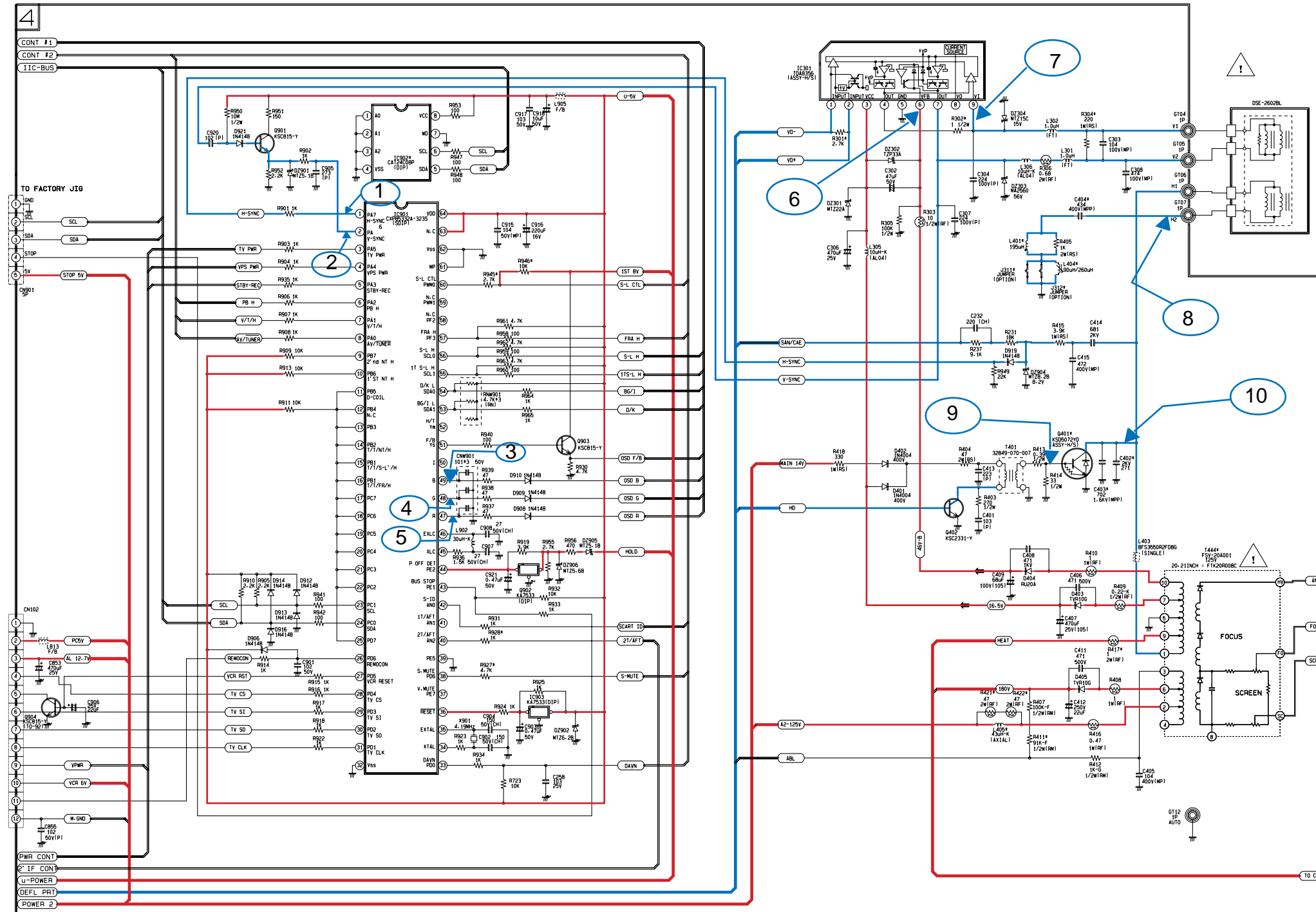

RED — POWER LINE
 BLUE — SIGNAL LINE

12-9 IF

2'nd IF PAL/SECAM-L/L' OPTION

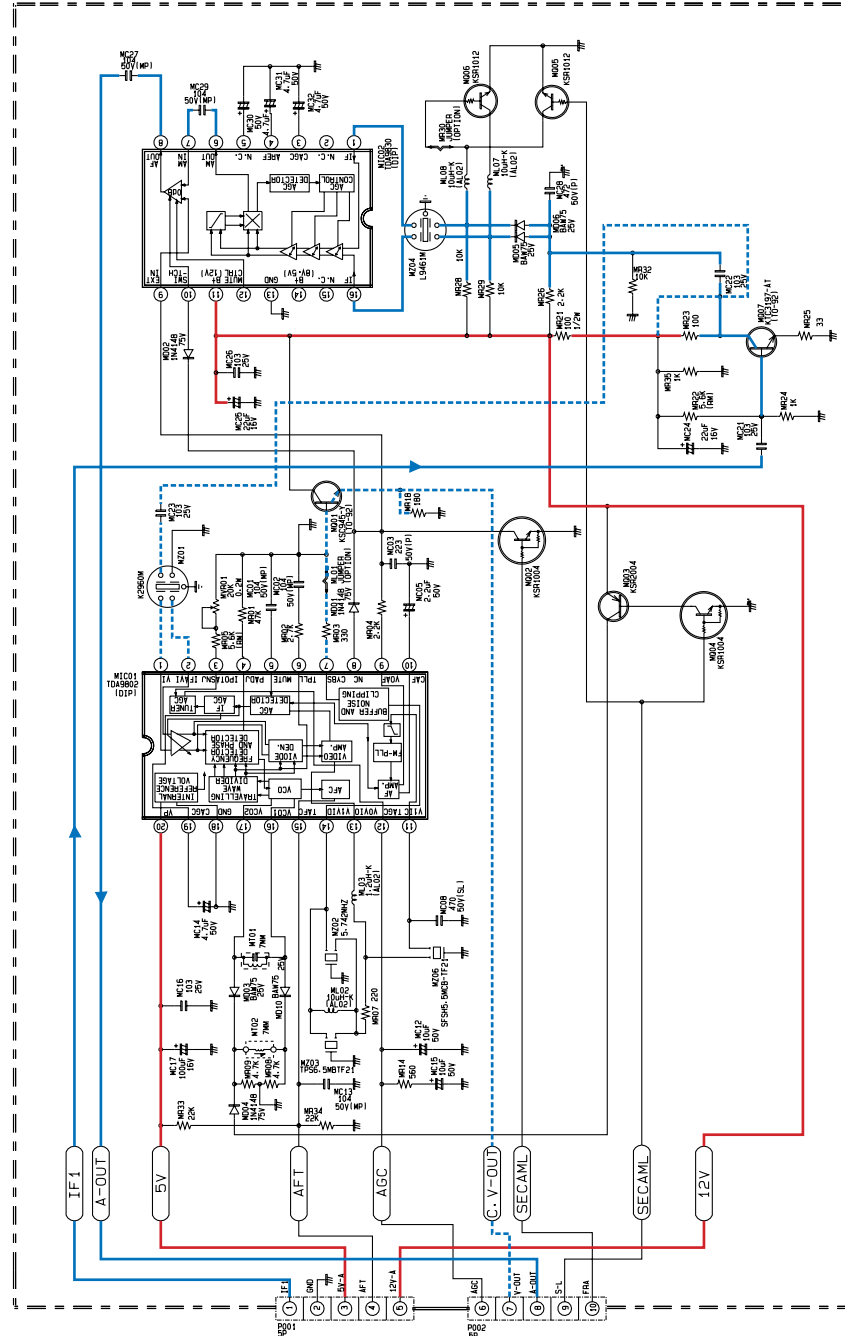

12-10 CRT

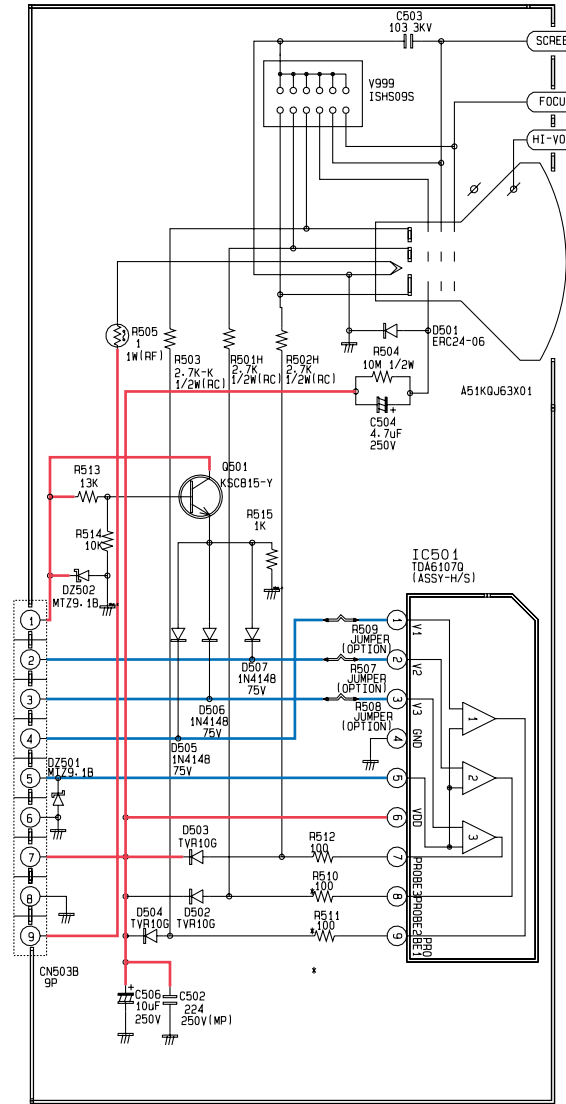

12-11 2'nd IF PAL/SECAM-B/G, D/K, I OPTION

2'nd IF PAL/SECAM-B/G, D/K, I OPTION

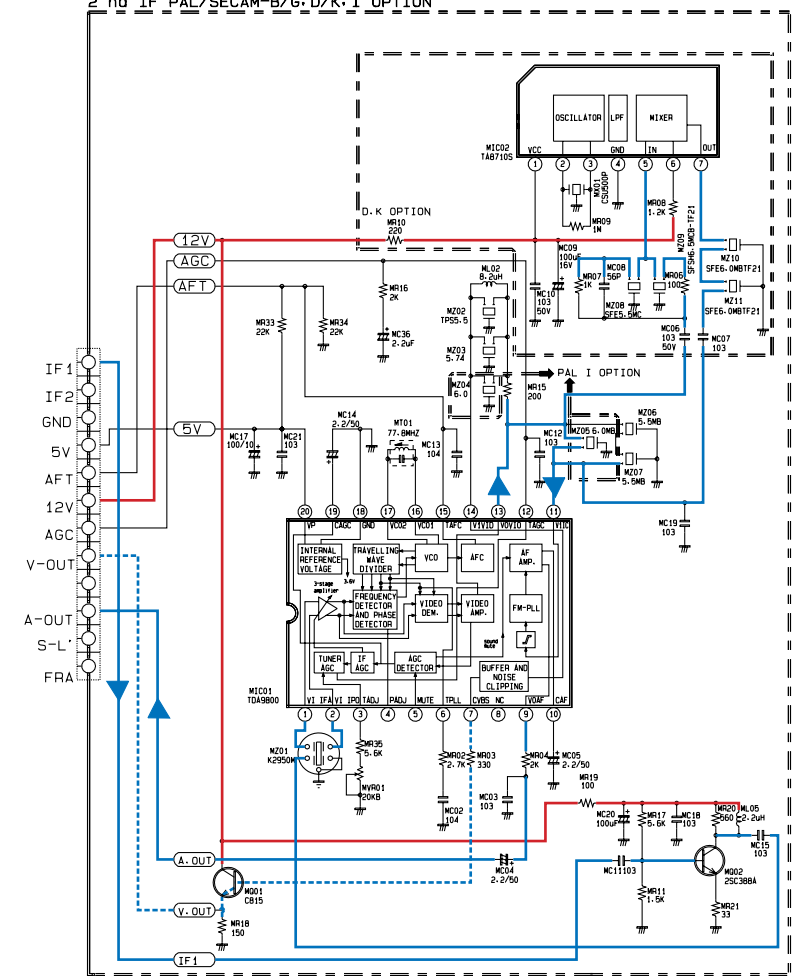

- RED - - - - - POWER LINE
- RED ———— AUDIO LINE
- BLUE ———— SIGNAL LINE
- BLUE ———— VIDEO LINE

12-12 TTX

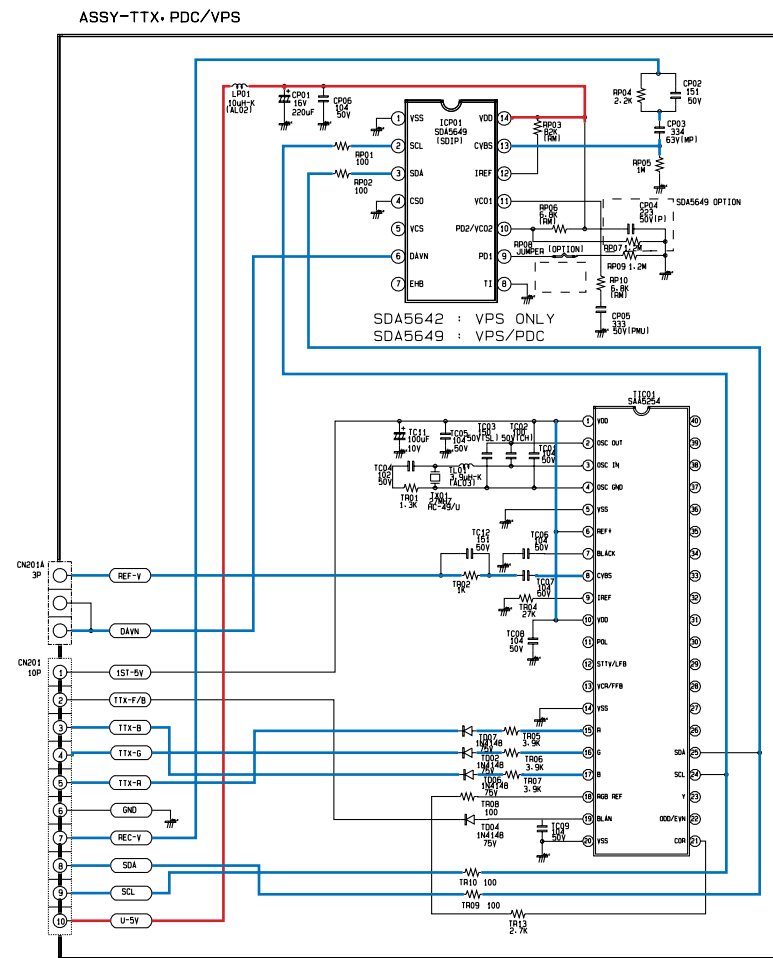

12-13 SECAM IF

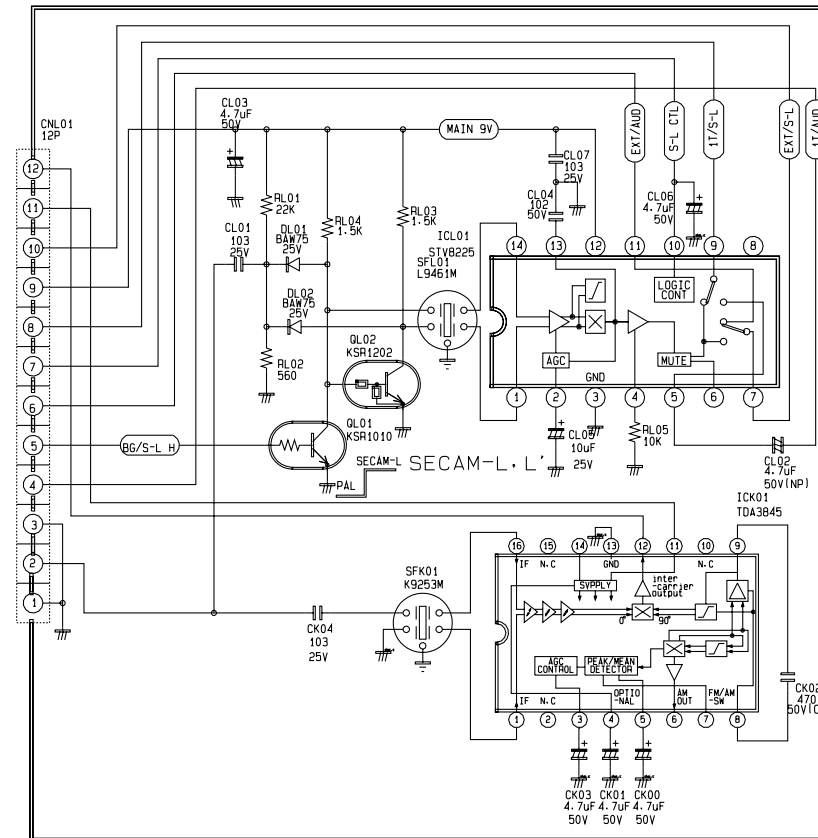

12-14 PAL, SECAM

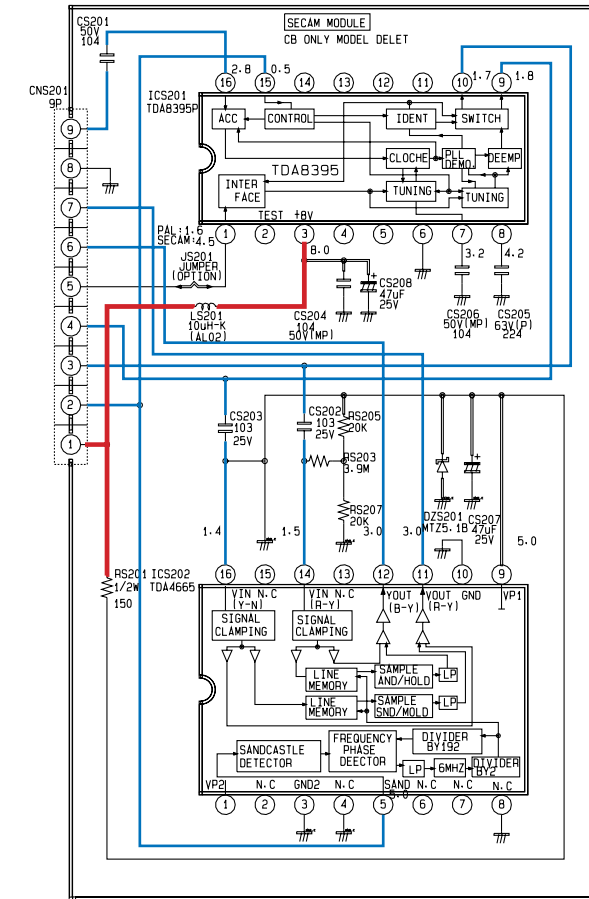

12-16 FRONT-A/V

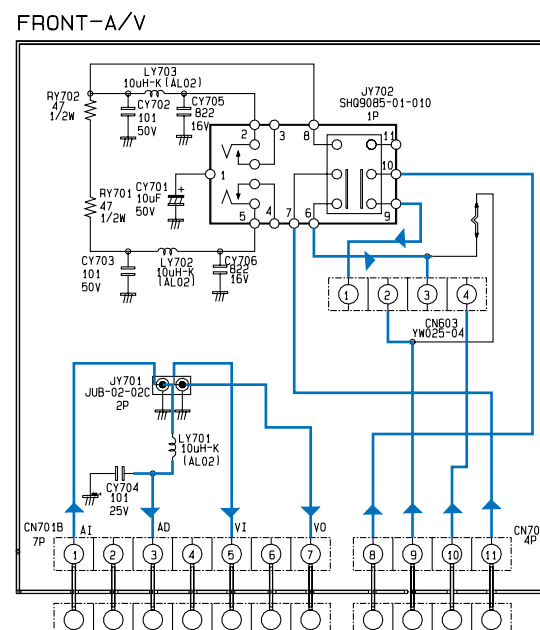

12-15 MASTER

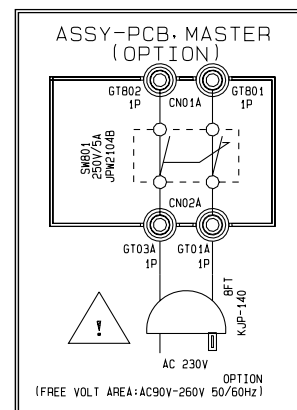

RED — POWER LINE
BLUE — SIGNAL LINE

12-17 Voltages (VTR)

ICM601

PIN NO	MODE	STOP	REC	PB
1		0	0	0
2		0	0	0
3		5	5	5
4		0	0	0
5		0	0	0
6		0	0	0
7		0	0	0
8		0	0	0
9		0.8	0	2.5
10		0	0	0
11		0	0	0
12		0	1.5	1.5
13		5	5	5
14		5	5	5
15		5	5	5
16		5	5	5
17		5	5	5
18		5	5	5
19		0	0	0
20		5	5	5
21		0	0	0
22		5	5	5
23		5	5	5
24		5	5	5
25		5	5	5
26		0	5	5
27		0	0	0
28		5	5	5
29		0	0	0
30		0	0	0
31		2.6	3	2.6
32		2.6	3	2.6

PIN NO	MODE	STOP	REC	PB
33		0	0	0
34		2.5	2.5	2.5
35		2.6	2.6	2.6
36		2.6	2.6	2.6
37		2.6	2.6	2.6
38		0.6	4.0	4.0
39		2.6	2.6	2.6
40		5.0	5.0	5.0
41		0.2	5.0	5.0
42		0	0	0
43		0	0	0
44		0	0	0
45		0	0	0
46		0	0	0
47		0	0	0
48		0	0	0
49		0	0	0
50		0	0	0
51		0	0	0
52		5.2	5.2	5.2
53		0	0	0
54		0	3.6	3.6
55		5.2	5.2	5.2
56		5.2	5.2	5.2
57		0	0	0
58		2.6	2.6	2.6
59		2.6	2.6	2.6
60		0	0	0
61		5.2	5.2	5.2
62		0	0	0
63		5.2	5.2	5.2
64		0	0	0

PIN NO	MODE	STOP	REC	PB
65		0	0	0
66		0	0	5.4
67		0	5.0	5.0
68		0	0	0
69		2.5	2.5	2.5
70		0	0.6	0
71		0	0	0
72		4.0	4.0	4.0
73		4.5	4.5	4.5
74		0	0	0
75		5.0	5.0	5.0
76		0	0	5.0
77		0	5.0	0
78		0	0	0
79		0	0	0
80		0	0	0
81		0	0	0
82		4.5	4.5	4.5
83		5.0	5.0	5.0
84		5.0	5.0	5.0
85		5.0	5.0	5.0
86		5.0	5.0	5.0
87		5.0	4.5	0
88		0	5.0	0
89		0	0	0
90		0	0	0
91		0	0	0
92		0	0	0
93		0	0	0
94		0	0	0
95		5.0	0	5.0
96		5.0	5.0	5.0

PIN NO	MODE	STOP	REC	PB
97		0	5.0	5.0
98		5.0	5.0	5.0
99		5.0	5.0	5.0
100		5.0	5.0	5.0

ICM201

PIN NO	MODE	STOP	REC	PB
1		2.5	3.0	3.0
2		2.5	2.5	2.5
3		2.5	2.5	2.5
4		5.0	5.0	5.0
5		2.5	2.5	2.5
6		2.5	2.5	2.5
7		4.0	4.0	4.0
8		0.6	4.0	4.0
9		3.2	3.2	3.2
10		2.8	2.8	2.8
11		0	0	0
12		0	2.5	2.5
13		0	2.5	2.5
14		0	2.5	2.5

ICM603

PIN NO	MODE	STOP	REC	PB
1		0	0	0
2		0.4	0.4	0.4
3		2.5	2.5	2.5
4		2.5	2.5	2.5
5		2.5	2.5	2.5
6		4	4	4
7		6.5	6.5	6.5
8		13.5	13.5	13.5
9		13.5	13.5	13.5
10		0	0	0

12-18 Voltages (TV)

* Conditions of Measurement

1. Normal Condition
2. Receiving Color Bar Pattern
3. DC Voltage

Q801 STR6707

Units :Volts

PIN NO.	PIN NAME	STAND-BY	POWER ON
1	C	298	291
2	E	-	-
3	B	0.8	0.5
4	SINK	-	0.7
5	DRIVE	-	1.3
6	OCP	-	-
7	F/B	-	-
8	INH	-	1.3
9	B+	6.3	7.7

IC801 LTV817B

Units :Volts

PIN NO.	STAND-BY	POWER
1	9.2	14.3
2	8.2	13.3
3	3.2	1.2
4	6.3	7.7

IC501-IC503 TDA6101Q

Units :Volts

PIN NO.	PIN NAME	VOLTAGES (V)
1	Vip	2.1
2	Vcc	12.3
3	Vin	2.1
4	GND	-
5	Iom	8.3
6	Vdd	172.6
7	Vcn	96-120
8	Vcc	96-120
9	Vof	96-120

IC301 TDA8356

PIN NO.	PIN NAME	VOLTAGES (V)
1	VD-INPUT	2.2
2	VD+ INPUT	2.2
3	Vcc	15.8
4	OUTPUT	7.6
5	GND	-
6	VFB	43.2
7	OUT	8.0
8	VO	-
9	VI	7.7

IC602 TDA7056

PIN NO.	PIN NAME	VOLTAGES (V)
1	NC	12.1
2	Vcc	12.1
3	IN	-
4	GND	-
5	NC	-
6	A+	6.2
7	GND	-
8	A-	6.0
9	NC	-

IC902 24C08, 24C04

PIN NO.	PIN NAME	VOLTAGE (V)
1	GND	-
2	GND	-
3	GND	-
4	GND	-
5	SDA	4.8
6	SCL	4.8
7	GND	-
8	VDD	5.2

IC601 TDA7057AQ

PIN NO.	PIN NAME	VOLTAGES (V)
1	VOL 1	1.2
2	SIG.GND	-
3	IN 1	2.4
4	Vcc	12.1
5	IN 2	2.4
6	SIG.GND	-
7	VOL 2	1.2
8	OUT 2+	5.6
9	PWA GND	-
10	OUT 2-	5.7
11	OUT 1-	5.7
12	PWA GND	-
13	OUT 1+	5.7

12-18 Voltages (TV)

IC901 CXP853P40S-1

PIN NO.	PIN NAME	VOLTAGES (V)
1	H-sync	1.2
2	V-sync	0.0
3	TV POWER	5.1
4	VPS POWER	-
5	STBY-REC	-
6	PB-H	0.0
7	V/T/H	-
8	AV/TUNER	0.0
9	2nd NT H	5.1
10	1st NT H	5.1
11	D-coil	-
12 - 22	Not used	5.1
23	SCL	4.7
24	SDA	4.7
25	No used	5.1
26	REMOCON	5.4
27	VCR RESET	5.1
28	TV CS	4.2
29	TV SI	4.0
30	TV SO	2.1
31	TV CLK	5.0
32	Vss	-
33	DAVN	5.1

* Pin No 4, 5, 6, 7, 8, 11, 33, 38, 42 are High, Low output ports.

IC201 TDA8374

PIN NO.	PIN NAME	VOLTAGES (V)
34	Xtal	2.5
35	EXtal	2.4
36	RESET	5.1
37	V.MUTE	-
38	S.MUTE	-
39	GND	-
40	2T AFT	3.0
41	1T AFT	-
42	SCART ID	-
43	BUS STOP	5.1
44	P OFF DET	5.5
45	XLC	3.0
46	EXLC	3.0
47	OSD R	-
48	OSD G	-
49	OSD B	-
50	NC	-
51	F/B	-
52 - 59	NC	-
60	S-L CTL	-
61 - 62	GND	-
63 - 64	VDD	5.1

PIN NO.	PIN NAME	VOLTAGES (V)
1	SOUND IF INPUT	-
2	EXT AUDIO INPUT	3.9
3	VCO REF FILTER	3.6
4	VCO REF FILTER	3.6
5	PLL LOOP FILTER	2.7
6	IF VIDEO OUTPUT	3.4
7	SCL	4.7
8	SDA	4.7
9	BANDGAP DECOUPLING	6.7
10	CHROMA INPUT	-
11	Y/CVBS INPUT	3.4
12	MAIN B+	8.0
13	INT CVBS INPUT	3.8
14	GND	-
15	AUDIO OUT	3.4
16	DECOUPLING FILTER TUNING	3.6
17	EXT CVBS INPUT	3.4
18	BLACK CURRENT INPUT	6.8
19	BLUE OUTPUT	2.6
20	GREEN OUTPUT	2.5
21	RED OUTPUT	2.7
22	BEAM CUR LIMITER	2.9
23	RED INPUT	3.4
24	GREEN INPUT	3.4
25	BLUE INPUT	3.4
26	RGB SWITCH INPUT	0.2
27	Y INPUT	1.9
28	Y OUTPUT	2.5

PIN NO.	PIN NAME	VOLTAGES (V)
29	B-Y OUTPUT	1.8
30	R-Y OUTPUT	1.8
31	B-Y OUTPUT	3.9
32	R-Y INPUT	3.9
33	SECAM REF OUTPUT	1.6
34	X-TAL (3.58)	2.6
35	X-TAL (4.43)	2.6
36	LOOPFILTER BURST PHASE DET	4.8
37	VCC	8.0
38	CVBS OUTPUT	3.3
39	BLACK PEAK HOLD CAPACITOR	4.0
40	HOR. OUTPUT	0.4
41	SANDCASTLE OUTPUT	0.5
42	PHI2 FILTER	4.1
43	PHI 1 FILTER	3.9
44	GND	-
45	EAST-WEST DRIVE	-
46	VERT DRIVE POS	2.2
47	VERT DRIVE NEG	2.2
48	IF INPUT	4.2
49	IF INPUT	4.2
50	EHT/OVP INPUT	2.1
51	VERT. SAWTOOTH CAPACITOR	3.9
52	REF. CURR INPUT	3.9
53	AGC DECOUPLING CAPACITOR	3.2
54	TUNER AGC OUTPUT	5.8
55	AUDIO DEEMPHASSIS	3.0
56	DECOUPLING SOUND DEMOD.	4.0

12-18 Voltages (TV)**Terminal Voltages of ICs**

Unit : Voltage (V)

PIN NO	IC	IC203*	IC202	IC701	ICK01*	ICL01*	IC702	IC703	IC704
		TDA8395P	TDA4665	TC4053BP	TDA3845	STV8225	KA8405	KA8405	KA8404
1		4.5	5.0	-	1.8	4.2	6.1	6.1	6.1
2		1.1	-	-	-	3.2	0.9	0.9	-
3		8.1	-	-	2.0	-	6.1	6.1	6.1
4		-	-	0.9	4.4	0.6	-	-	-
5		-	0.5	0.9	-	4.3	-	-	0.9
6		-	-	-	1.7	3.5	6.1	6.1	5.3
7		3.3	-	-	1.7	4.3	-	-	9.0
8		4.2	-	-	5.1	6.3	5.3	5.3	
9		2.9	5.0	0.9	5.1	4.3	9.0	9.0	
10		2.9	-	0.9	-	3.5			
11		-	3.0	0.9	12.0	4.3			
12		-	3.1	4.3	1.8	9.0			
13		-	-	-	-	4.3			
14		-	1.6	4.3	6.1	4.3			
15		0.5	-	-	0.6				
16		2.8	1.4	9.0	1.8				