



# 8mm CAMCORDER

VP-A20/VP-A21

VP-A22/VP-A23

8

# **SERVICE** Manual

For mechanical disassembly and adjustment, refer to the "Mechanical Manual" (DE-6 → AD68-30200A).

## 8mm CAMCORDER

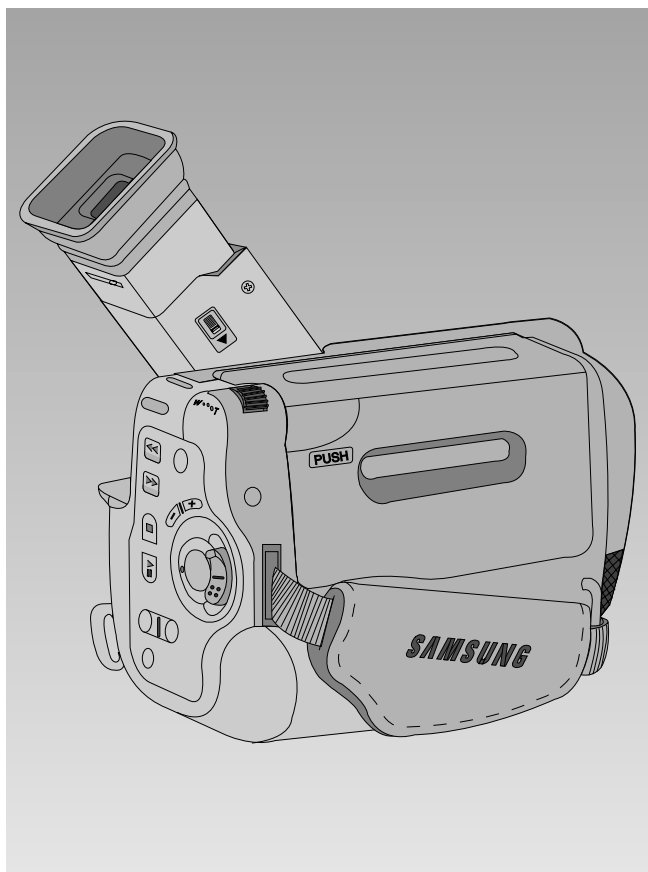

## CONTENTS

1. Precautions
2. Reference Information
3. Product Specifications and Comparison Chart
4. Disassembly and Reassembly
5. Alignment and Adjustment
6. Exploded View and Parts List
7. Electrical Parts List
8. Block Diagrams
9. PCB Diagrams
10. Wiring Diagram
11. Schematic Diagrams

# 1. Precautions

1. Be sure that all of the built-in protective devices are replaced. Restore any missing protective shields.
2. When reinstalling the chassis and its assemblies, be sure to restore all protective devices, including : control knobs and compartment covers.
3. Make sure that there are no cabinet openings through which people--particularly children --might insert fingers and contact dangerous voltages. Such openings include the spacing between the picture tube and the cabinet mask, excessively wide cabinet ventilation slots, and improperly fitted back covers.

If the measured resistance is less than 1.0 megohm or greater than 5.2 megohms, an abnormality exists that must be corrected before the unit is returned to the customer.

4. Leakage Current Hot Check (See Fig. 1) :  
Warning : Do not use an isolation transformer during this test. Use a leakage current tester or a metering system that complies with American National Standards Institute (ANSI C101.1, *Leakage Current for Appliances*), and Underwriters Laboratories (*UL Publication UL1410, 59.7*).
5. With the unit completely reassembled, plug the AC line cord directly the power outlet. With the unit's AC switch first in the ON position and then OFF, measure the current between a known earth ground (metal water pipe, conduit, etc.) and all exposed metal parts, including : antennas, handle brackets, metal cabinets, screwheads and control shafts. The current measured should not exceed 0.5 milliamp. Reverse the power-plug prongs in the AC outlet and repeat the test.
6. X-ray Limits :  
The picture tube is designed to prohibit X-ray emissions. To ensure continued X-ray protection, replace the picture tube only with one that is the same type as the original.

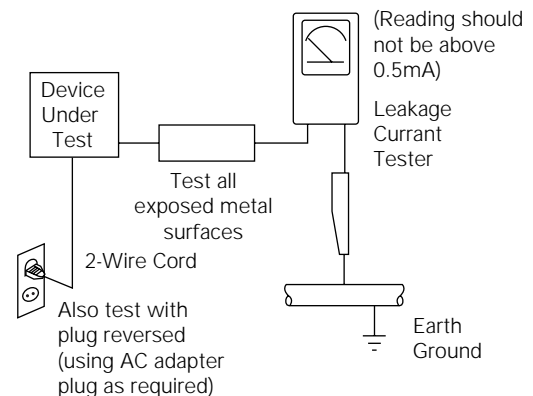



Fig. 1 AC Leakage Test

7. Antenna Cold Check :  
With the unit's AC plug disconnected from the AC source, connect an electrical jumper across the two AC prongs. Connect one lead of the ohmmeter to an AC prong. Connect the other lead to the coaxial connector.
8. High Voltage Limit :  
High voltage must be measured each time servicing is done on the B+, horizontal deflection or high voltage circuits.  
  
Heed the high voltage limits. These include the *X-ray protection Specifications Label*, and the *Product Safety and X-ray Warning Note* on the service data schematic.
9. Some semiconductor ("solid state") devices are easily damaged by static electricity. Such components are called Electrostatically Sensitive Devices (ESDs); examples include integrated circuits and some field-effect transistors. The following techniques will reduce the occurrence of component damage caused by static electricity.
10. Immediately before handling sny semiconductor components or assemblies, drain the electrostatic charge from your body by touching a known earth ground. Alternatively, wear a discharging Wrist-strap device. (Be sure to remove it prior to applying power--this is an electric shock precaution.)

11. High voltage is maintained within specified limits by close-tolerance, safety-related components and adjustments. If the high voltage exceeds the specified limits, check each of the special components.
12. Design Alteration Warning :  
Never alter or add to the mechanical or electrical design of this unit. Example : Do not add auxiliary audio or video connectors. Such alterations might create a safety hazard. Also, any design changes or additions will void the manufacturer's warranty.
13. Hot Chassis Warning :  
Some TV receiver chassis are electrically connected directly to one conductor of the AC power cord. If an isolation transformer is not used, these units may be safely serviced only if the AC power plug is inserted so that the chassis is connected to the ground side of the AC source.  
  
To confirm that the AC power plug is inserted correctly, do the following : Using an AC voltmeter, measure the voltage between the chassis and a known earth ground. If the reading is greater than 1.0V, remove the AC power plug, reverse its polarity and reinsert. Re-measure the voltage between the chassis and ground.
14. Some TV chassis are designed to operate with 85 volts AC between chassis and ground, *regardless of the AC plug polarity*. These units can be safely serviced *only* if an isolation transformer inserted between the receiver and the power source.
15. Never defeat any of the B+ voltage interlocks.  
Do not apply AC power to the unit (or any of its assemblies) unless all solid-state heat sinks are correctly installed.
16. Always connect a test instrument's ground lead to the instrument chassis ground *before* connecting the positive lead; always remove the instrument's ground lead last.
17. Observe the original lead dress, especially near the following areas : Antenna wiring, sharp edges, and especially the AC and high voltage power supplies. Always inspect for pinched, out-of-place, or frayed wiring. Do not change the spacing between components and the printed circuit board. Check the AC power cord for damage. Make sure that leads and components do not touch thermally hot parts.
18. Picture Tube Implosion Warning :  
The picture tube in this receiver employs "integral implosion" protection. To ensure continued implosion protection, make sure that the replacement picture tube is the same as the original.
19. Do not remove, install or handle the picture tube without first putting on shatterproof goggles equipped with side shields. Never handle the picture tube by its neck. Some "in-line" picture tubes are equipped with a permanently attached deflection yoke; do not try to remove such "permanently attached" yokes from the picture tube.
20. Product Safety Notice :  
Some electrical and mechanical parts have special safety-related characteristics which might not be obvious from visual inspection. These safety features and the protection they give might be lost if the replacement component differs from the original—even if the replacement is rated for higher voltage, wattage, etc.  
  
Components that are critical for safety are indicated in the circuit diagram by shading, (  or  ).  
Use replacement components that have the same ratings, especially for flame resistance and dielectric strength specifications. A replacement part that does not have the same safety characteristics as the original might create shock, fire or other hazards.

## 2. Reference Information

### 2-1 IC Blocks

#### 2-1-1 IC101 (M52369FP)

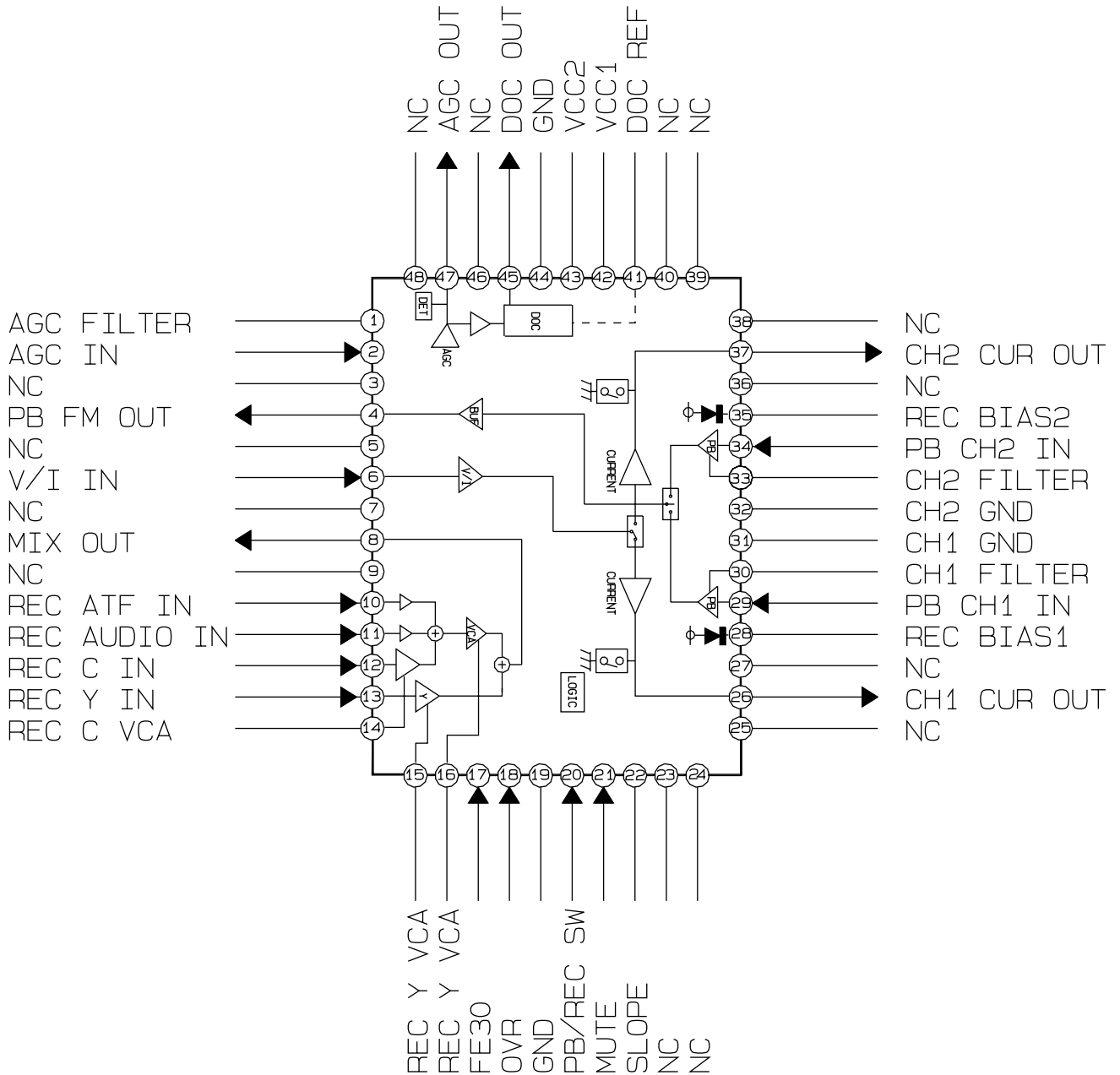

### 2-1-2 IC601 (CXP87240A)

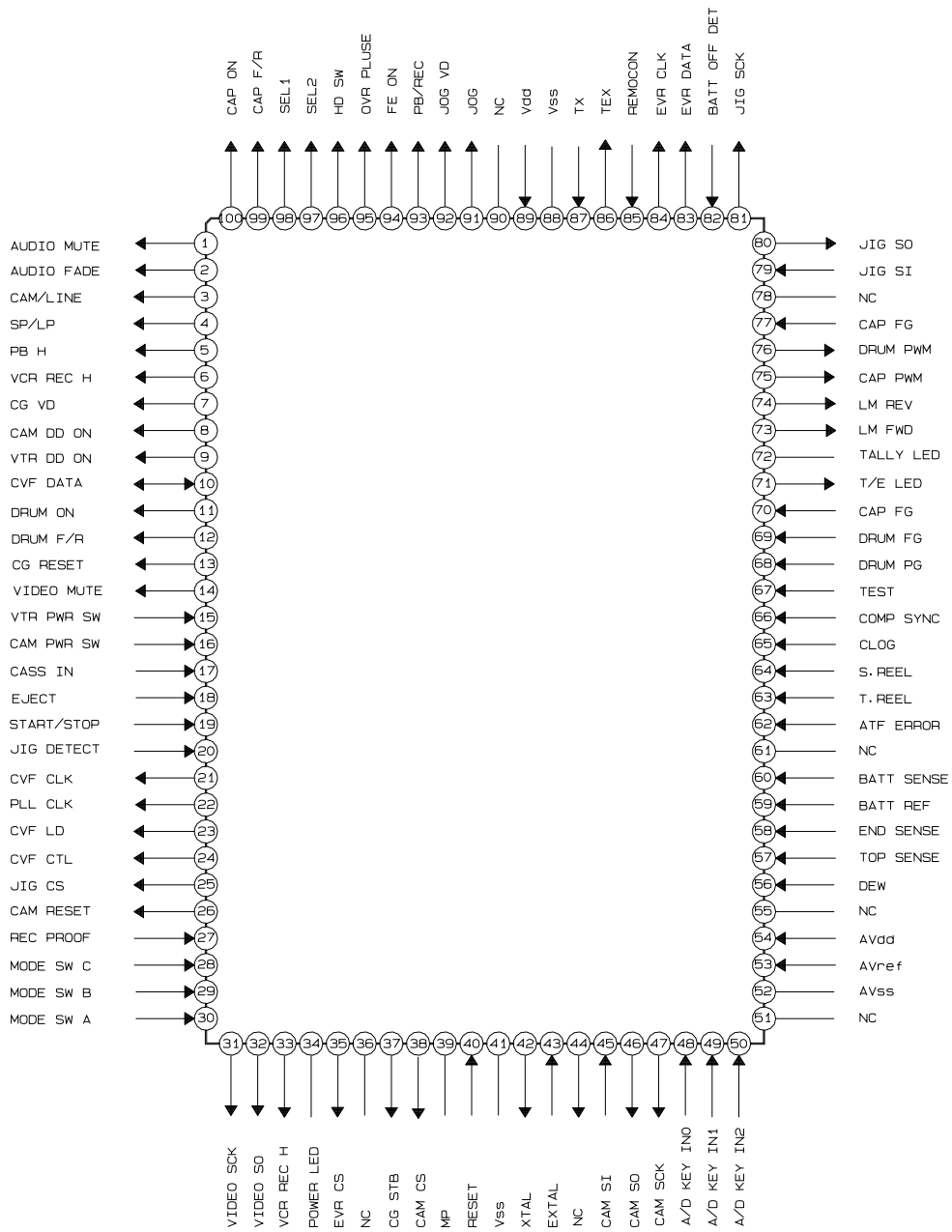

2-1-3 IC201 (CXA1700R)

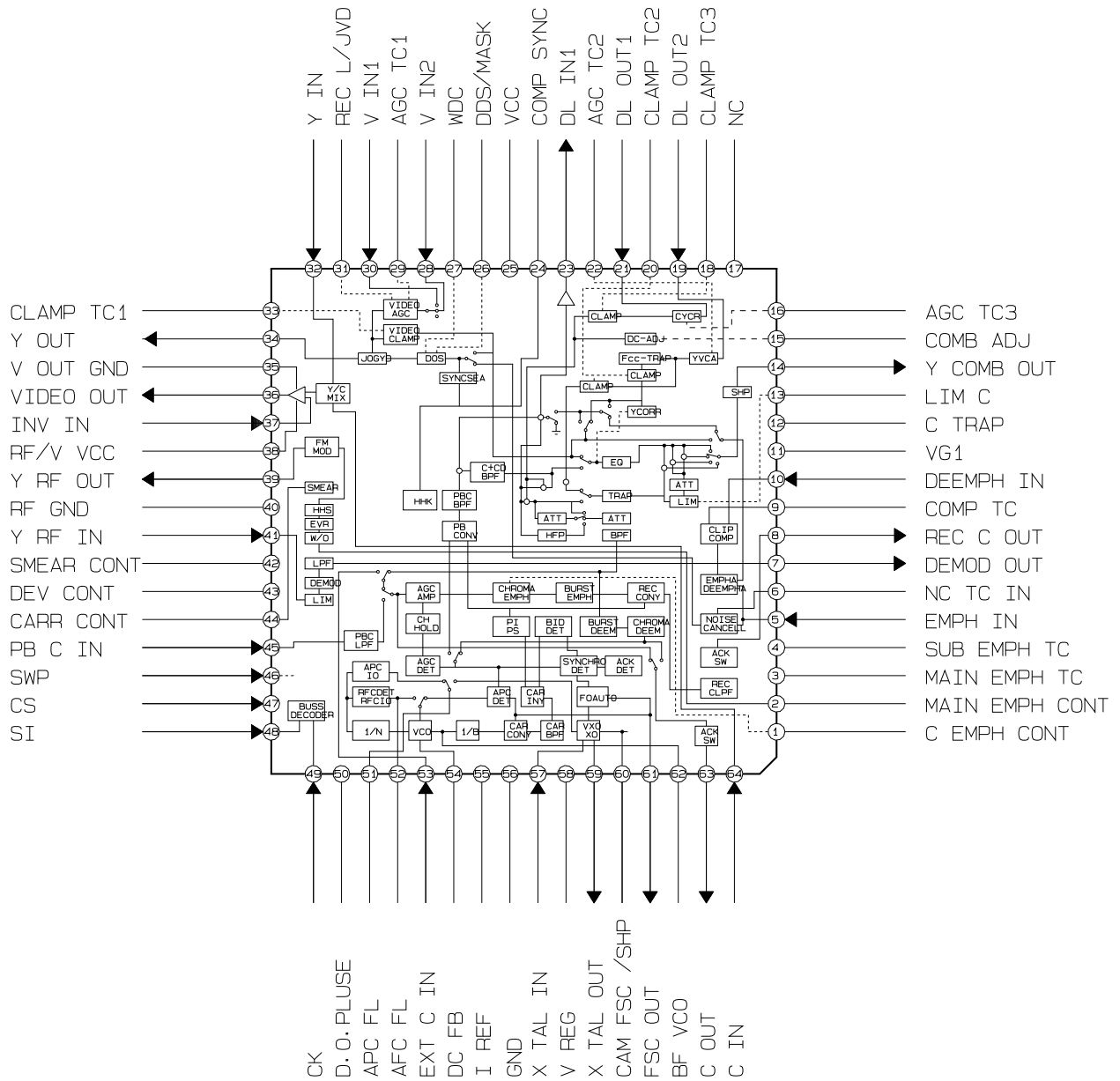

2-1-4 IC501 (KA8322)

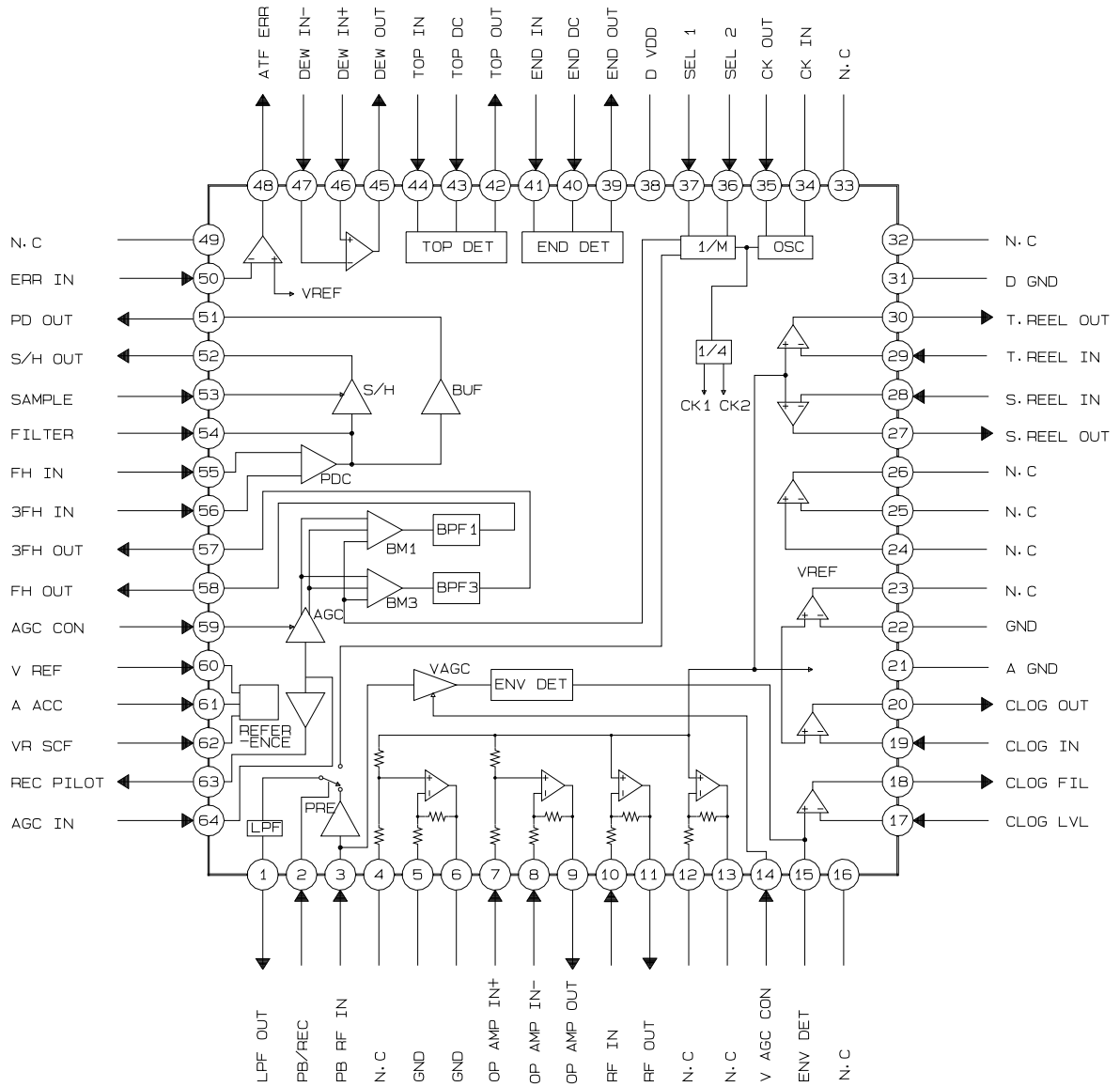

### 2-1-5 ICP01 (KS7213)

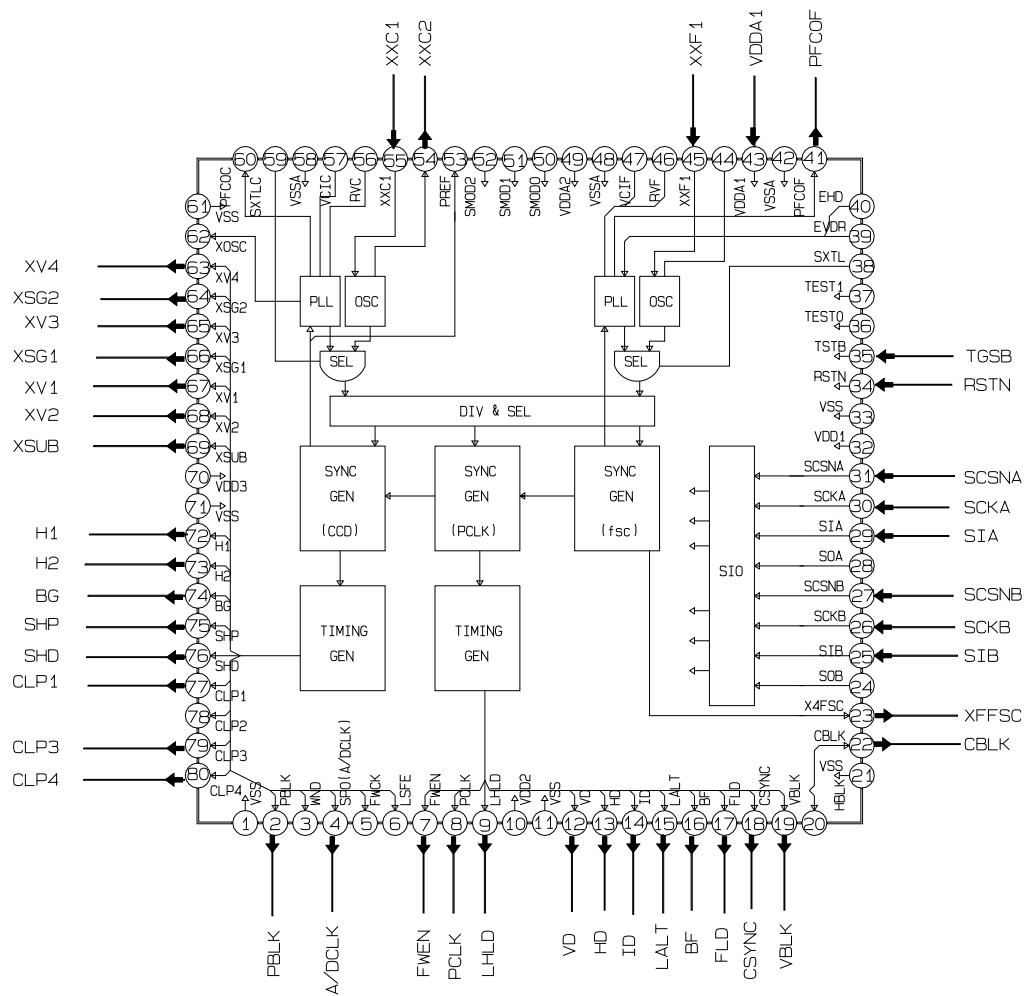

### 2-1-6 ICP03 (TDA8786A / AD CONVERTER)

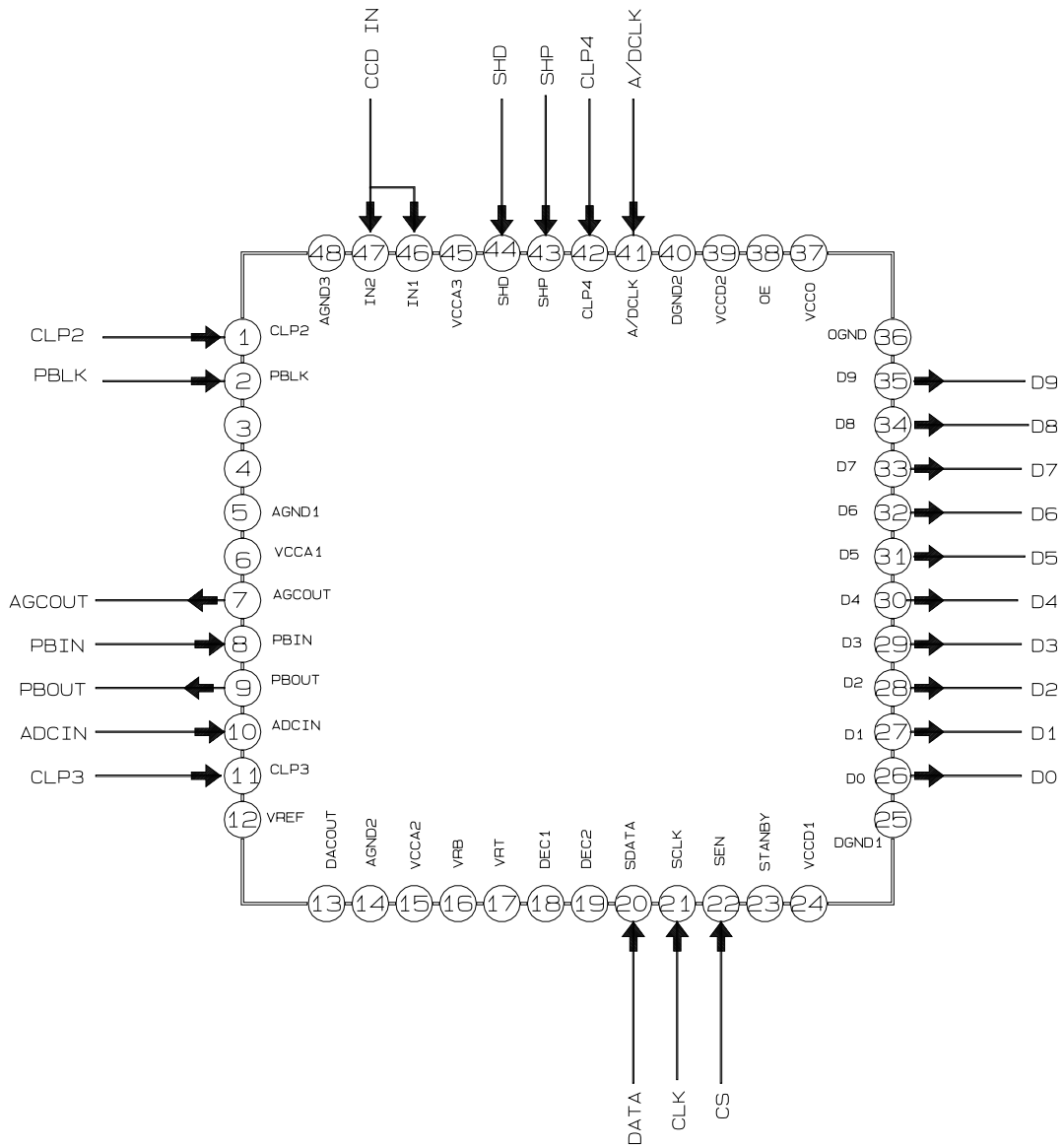

### 2-1-7 ICP04 (KS7306 / DSP)

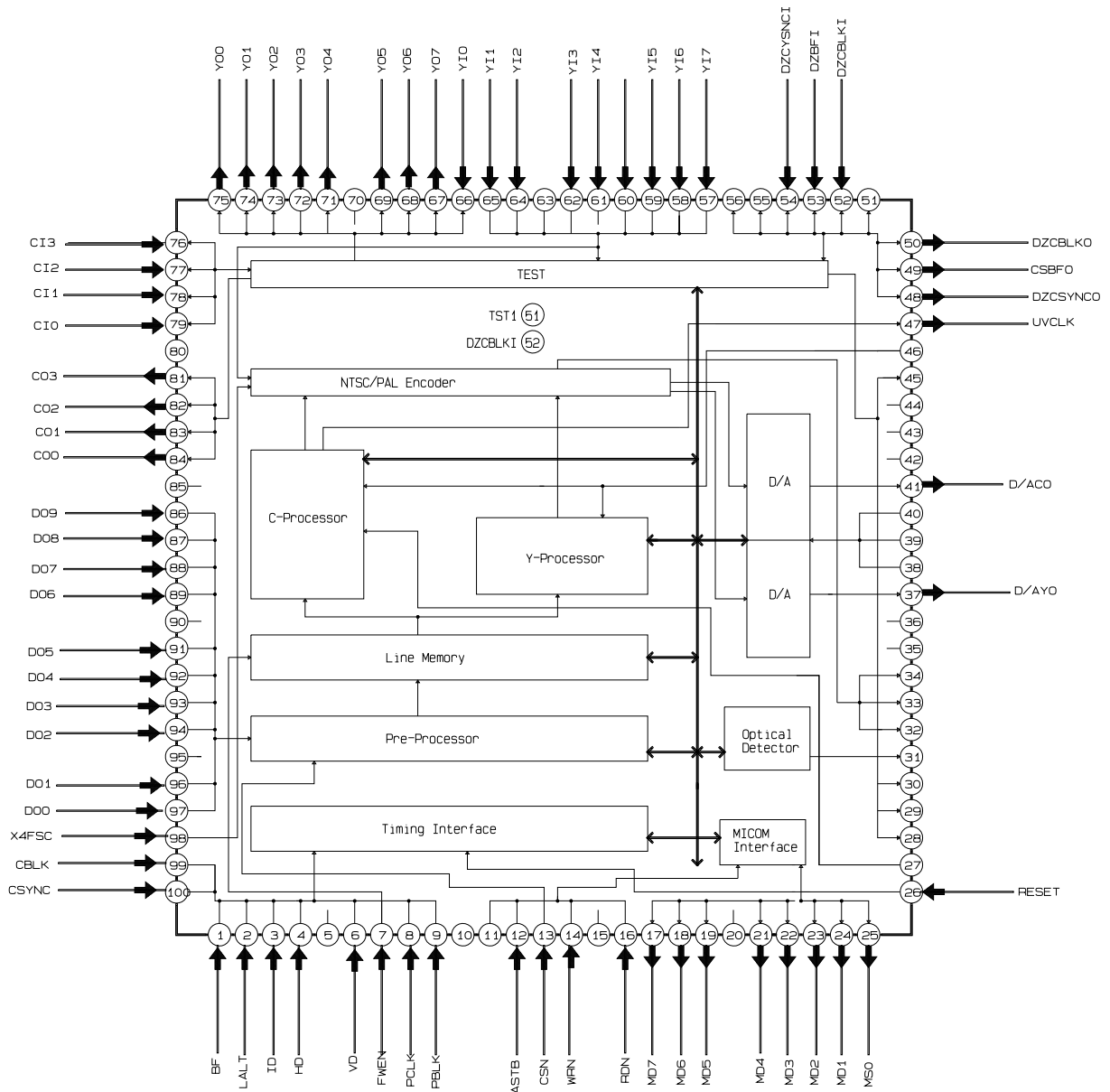

### 2-1-8 ICP05 (UPD784035 / AF MICOM)

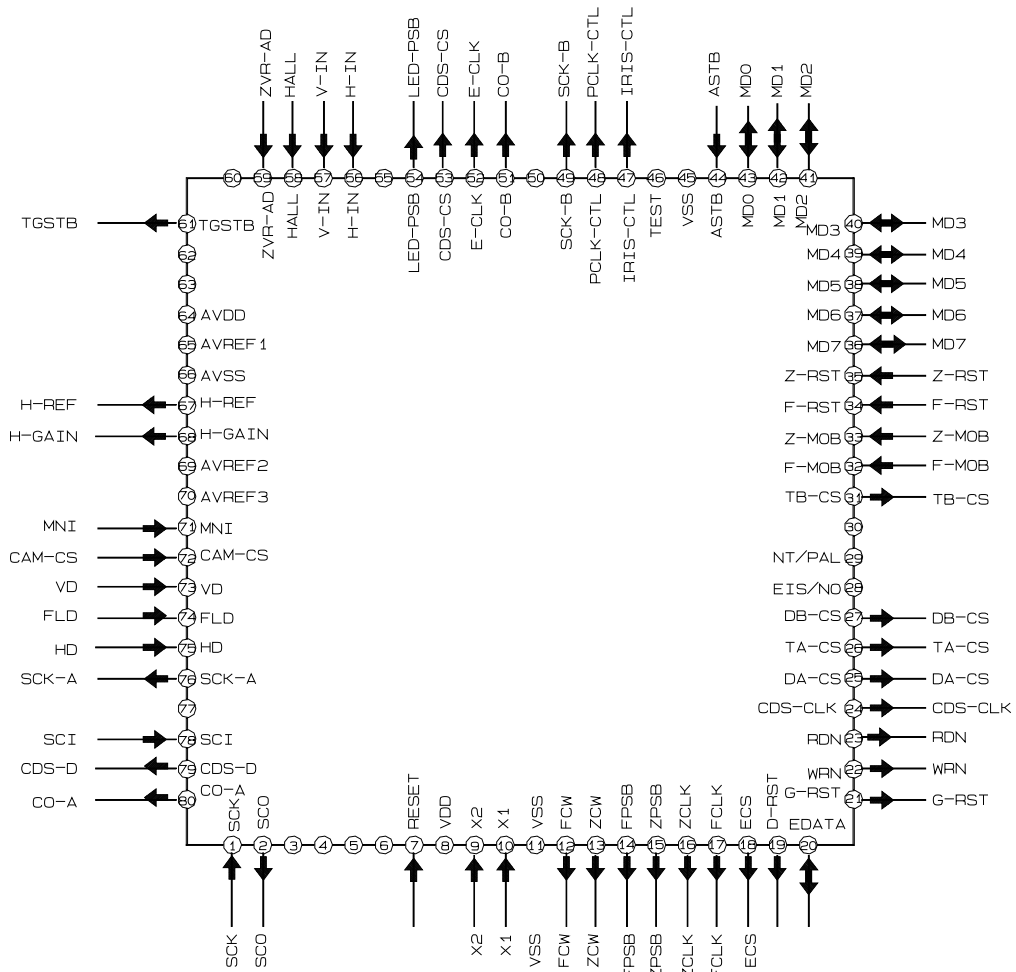

2-1-9 ICZ01 (KS7314 / D.ZOOM)

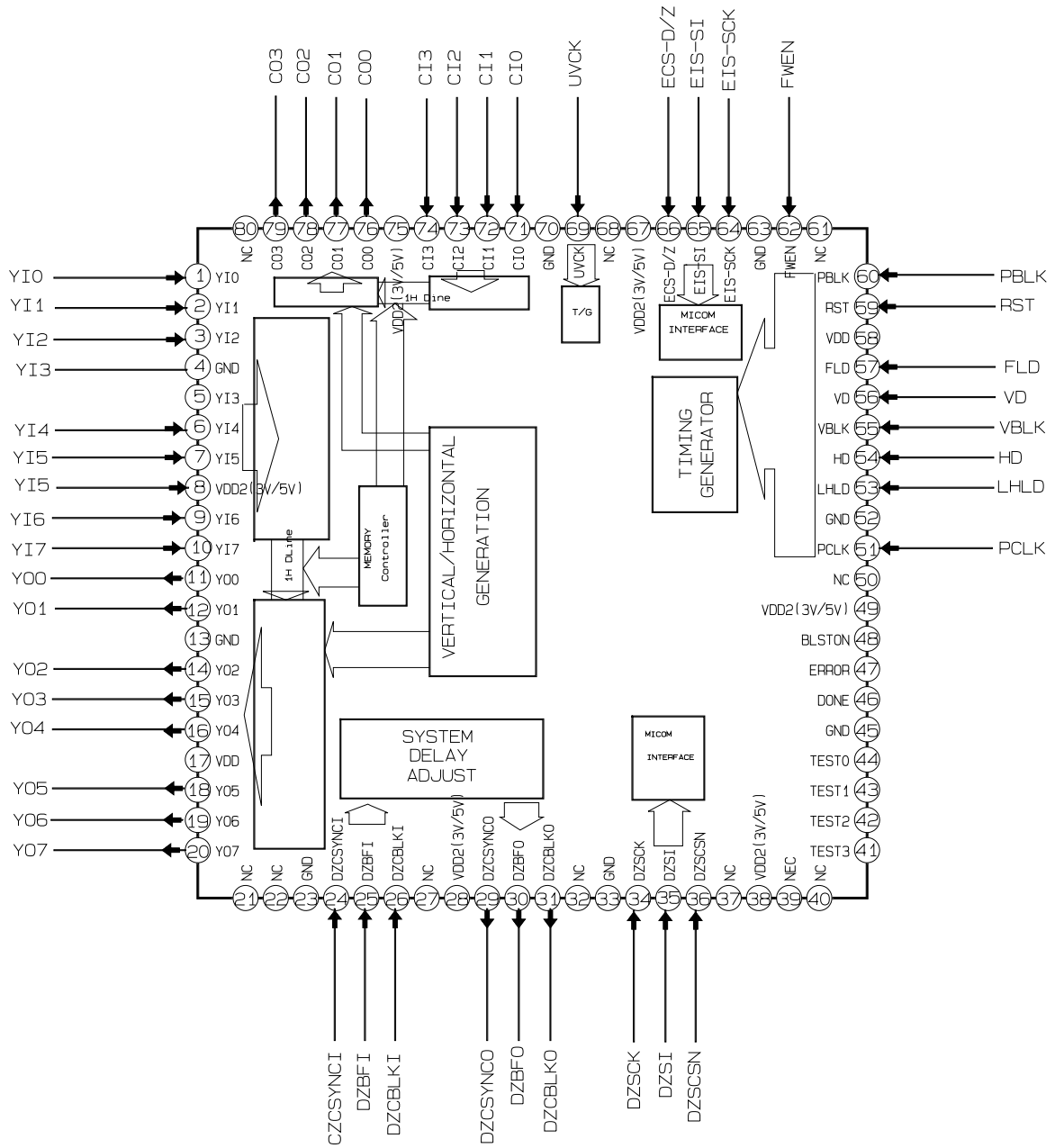

## 3. Product Specifications and Comparison Chart

### 3-1 Product Specifications

Design and specifications are subject to change without notice.

Operation	Description
SYSTEM	
Recording systems	Video : 2 rotary heads, helical scanning FM system Audio : FM system
Video signal	PAL color, EIA standard
Cassette format	8 mm
Tape speed	SP mode (Standard Play) : approx. 20.05 mm/sec.
Recording/ Playback time	SP mode (Standard Play) : 1 hour 30 minutes (P5-90)
Fast-forward/rewind time	Approx. 4 min (P5-60)
Image device	CCD (Charge Coupled Device)
Viewfinder	VP-A20/VP-A22 : Black and White electronic viewfinder VP-A23/VP-A21 : Color electronic viewfinder
Lens	VP-A23 : Combined 16x power zoom and 64x digital zoom VP-A22 : Combined 16x power zoom and 32x digital zoom VP-A20/VP-A21 : Combined 16x power zoom f=3.9 ~ 62.4 mm, F1.4 Auto wide macro
Automatic focus system	Inner
Color temperature	Auto
Lighting	300 lux (28 footcandles)
Aperture correction	Automatic with back light adjustment
INPUT/OUTPUT CONNECTORS	
Video output	Phono jack / 1Vp-p, 75 ohms, unbalanced, sync negative
Audio output	Phono jack, 7.5dBs for an output impedance of less than 2.2 Kohms
GENERAL	
Power requirement	AC power adaptor (7.5V) ; battery pack (6.0V)
Power consumption(in Camera mode)	5.2W
Tripod attachment thread	Attachment screw less than 9mm long
Microphone	Electric condensor microphone, omni-directional, monaural typ
Temperature range	Operation : 0°C to 40°C (32°F to 104°F); storage : -20°C to 60°C (-4°F to 140°F)
Dimensions/weight	Appros. 97 X 107 X 196 mm (3.8 X 4.2 X 7.7 inches) / approx. 700 g (1.54 lbs) Excluding battery pack and cassette

### 3-2 Comparison Chart

---

MODEL FUNCTION	VP-A20	VP-A22	VP-A23	VP-A21
CCD	320,000	320,000	320,000	320,000
VIEWFINDER	EVF	EVF	CVF	CVF
ZOOM	X16	X32 D.ZOOM	X64 D.ZOOM	X16
STEREO	MONO	MONO	MONO	MONO
P.AE	O	O	O	O
EIS	X	O	X	X

---

## 4. Disassembly and Reassembly

---

### 4-1 Cabinet Disassembly

---

#### 4-1-1 Cover Battery Removal

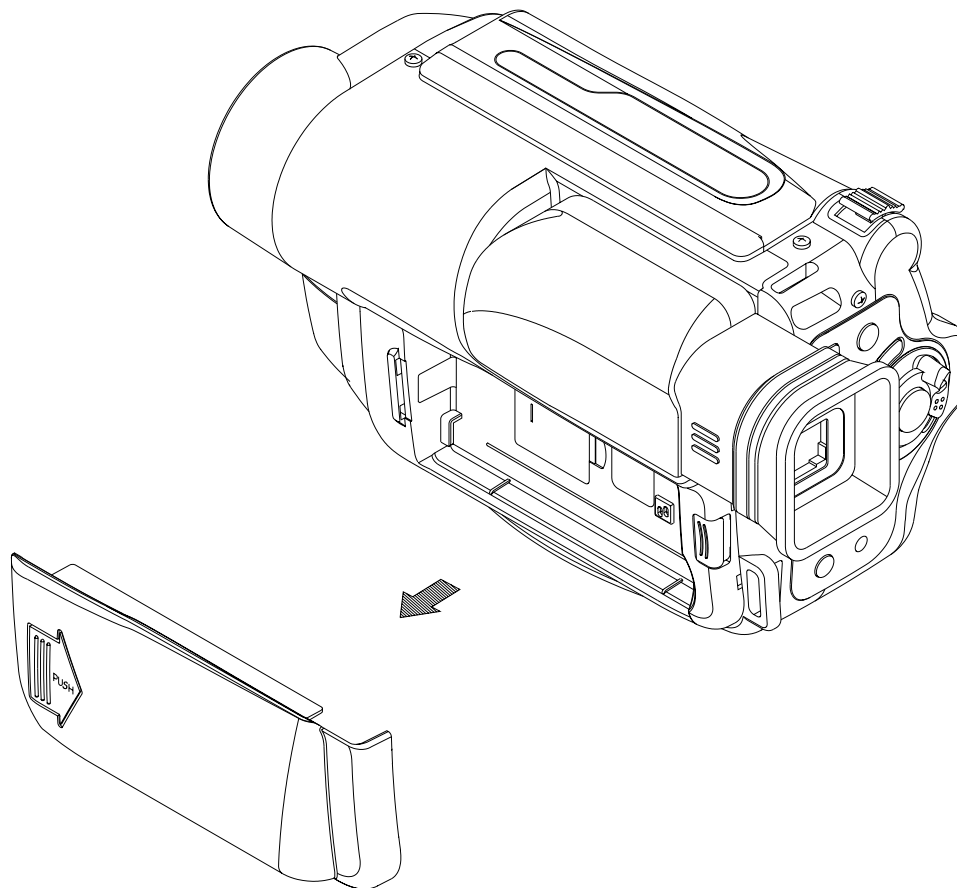

❶ PUSH THE COVER BATTERY AND REMOVE IT IN THE DIRECTION OF ARROW.

Fig. 4-1 Cover Battery Removal

### 4-1-2 Ass'y Cover Housing Removal

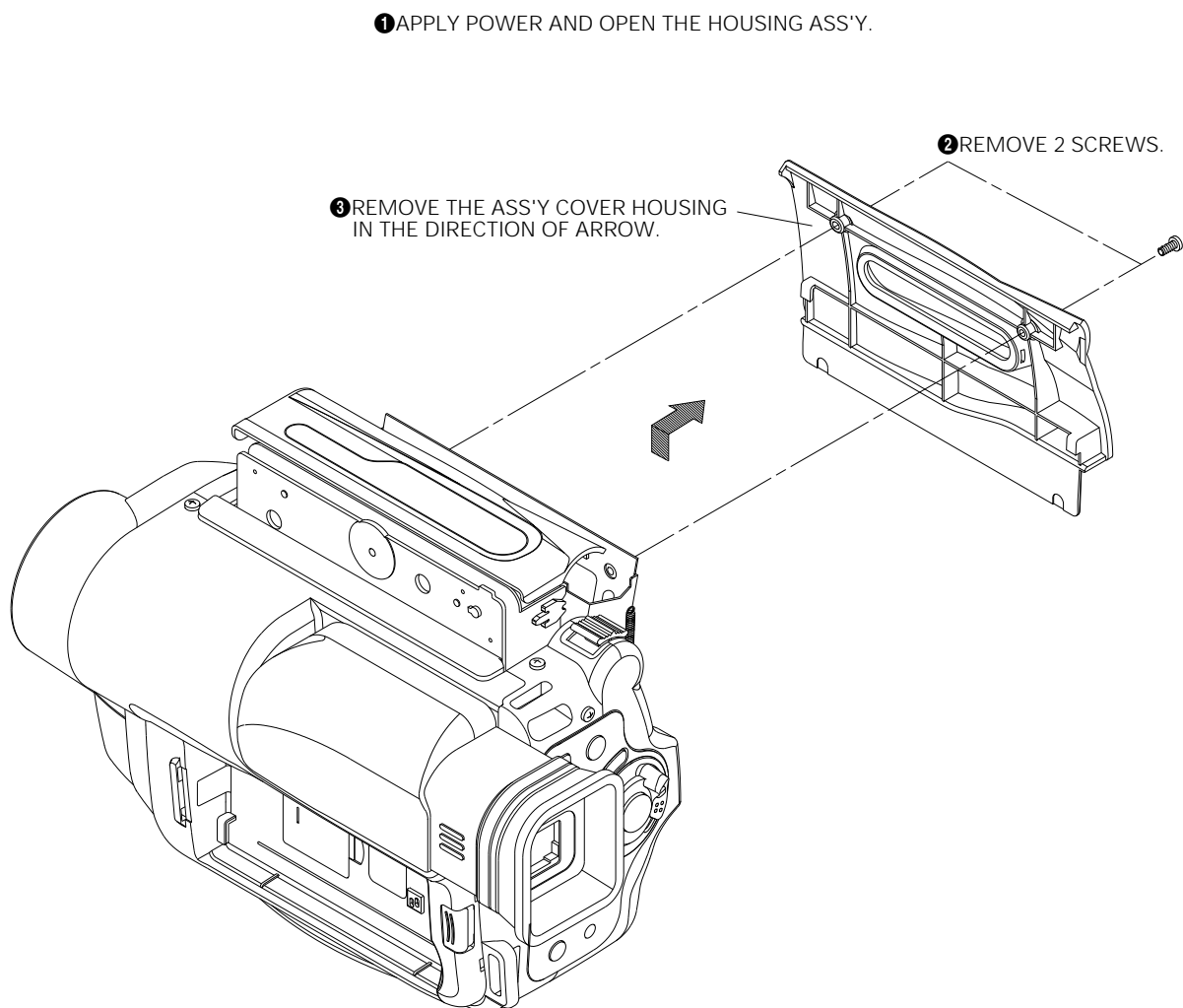

Fig. 4-2 Ass'y Cover Housing Removal

### 4-1-3 Ass'y Case Top Removal

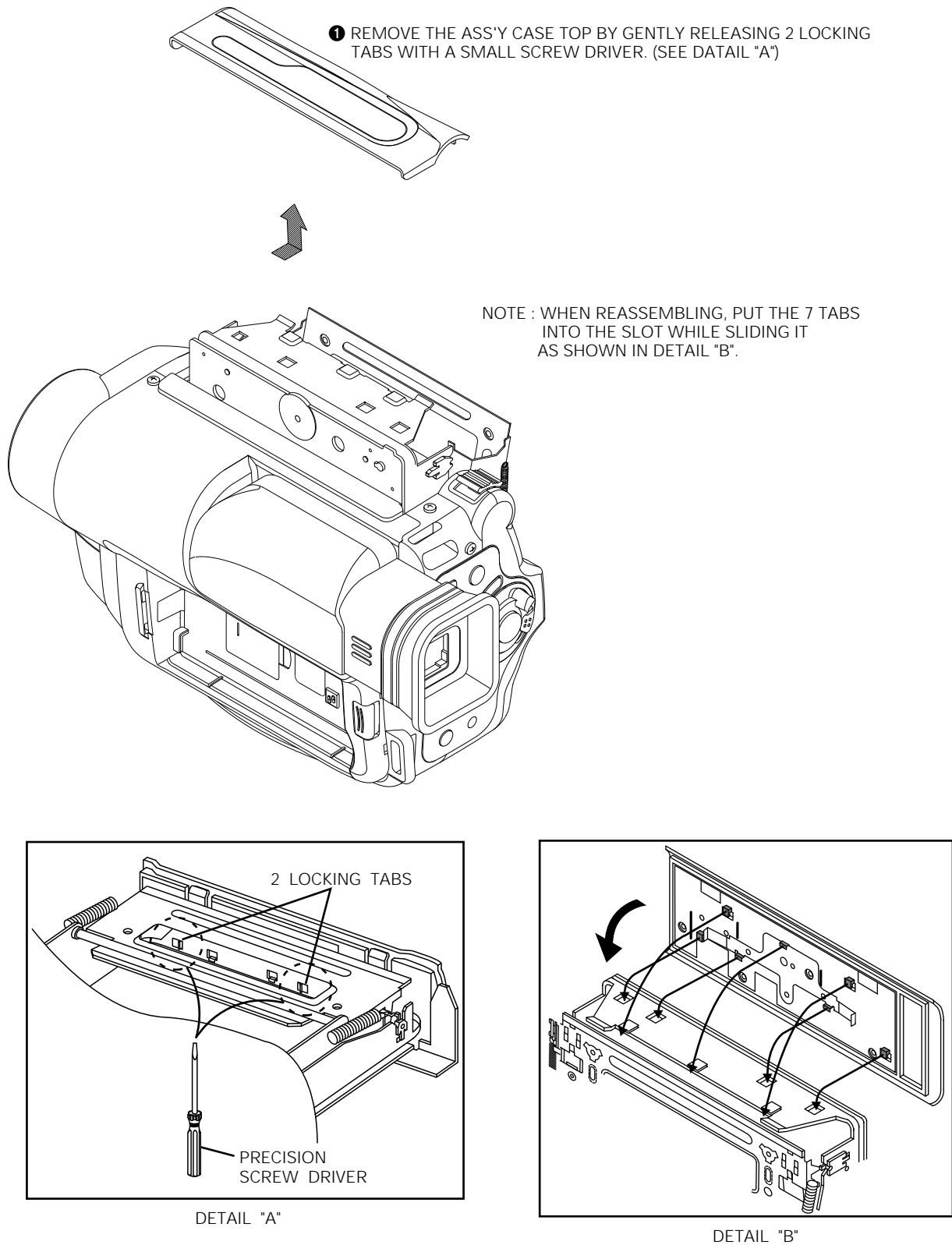

Fig. 4-3 Ass'y Case Top Removal

### 4-1-4 Ass'y Front Removal (1)

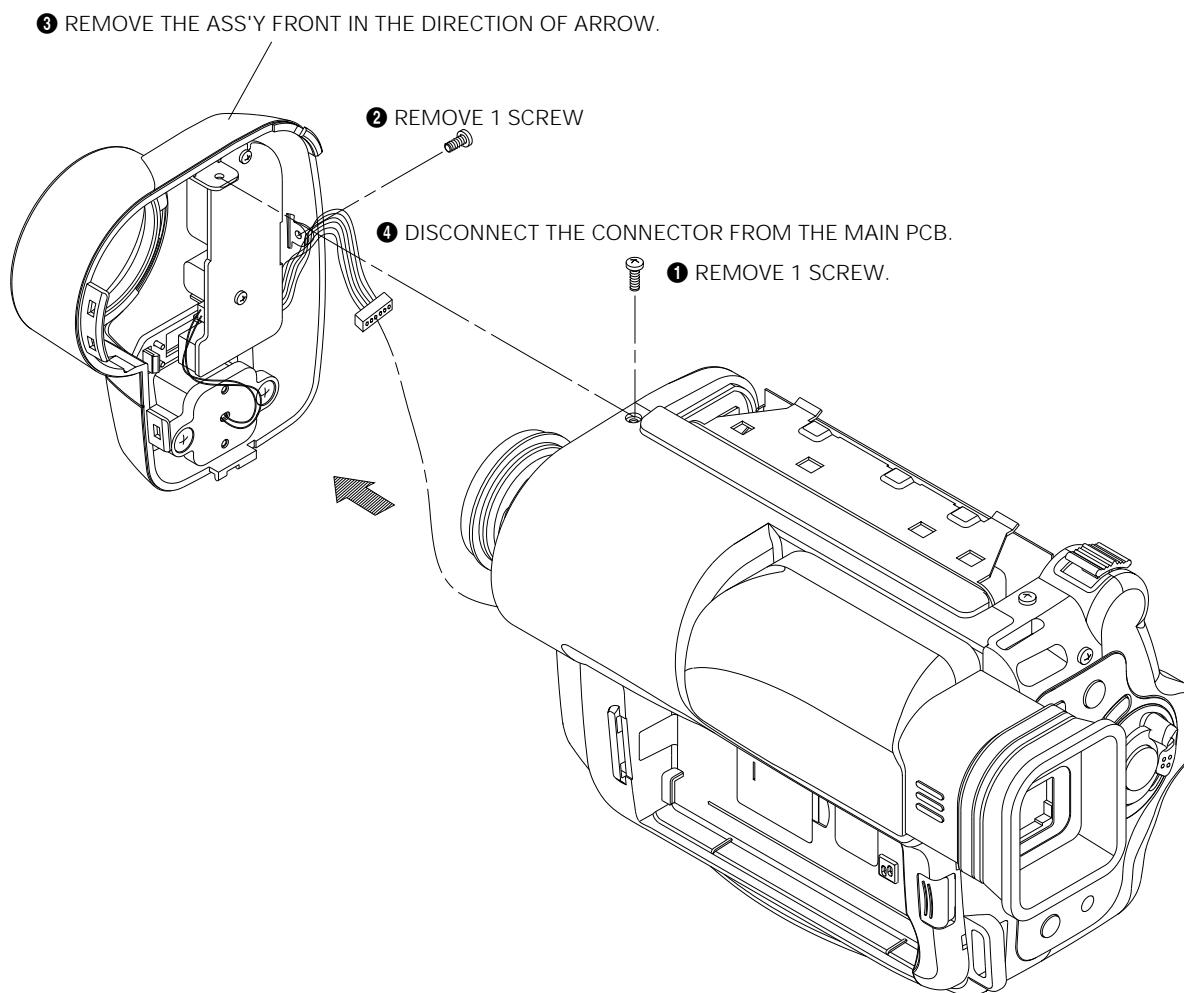

Fig. 4-4 Ass'y Front Removal (1)

### 4-1-5 Assy Front Removal (2)

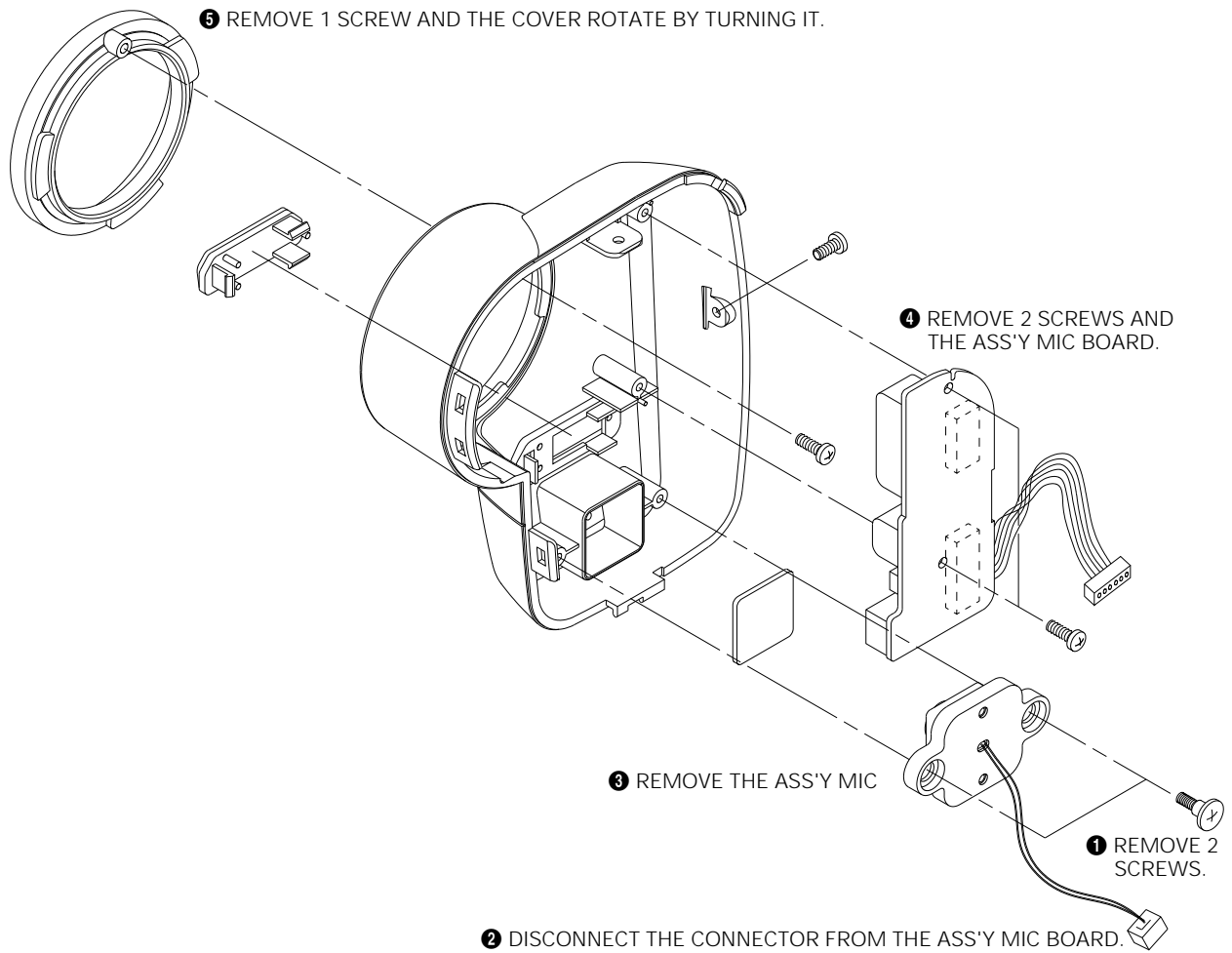

Fig. 4-5 Assy Front Removal

### 4-1-6 Ass'y Case Right Removal

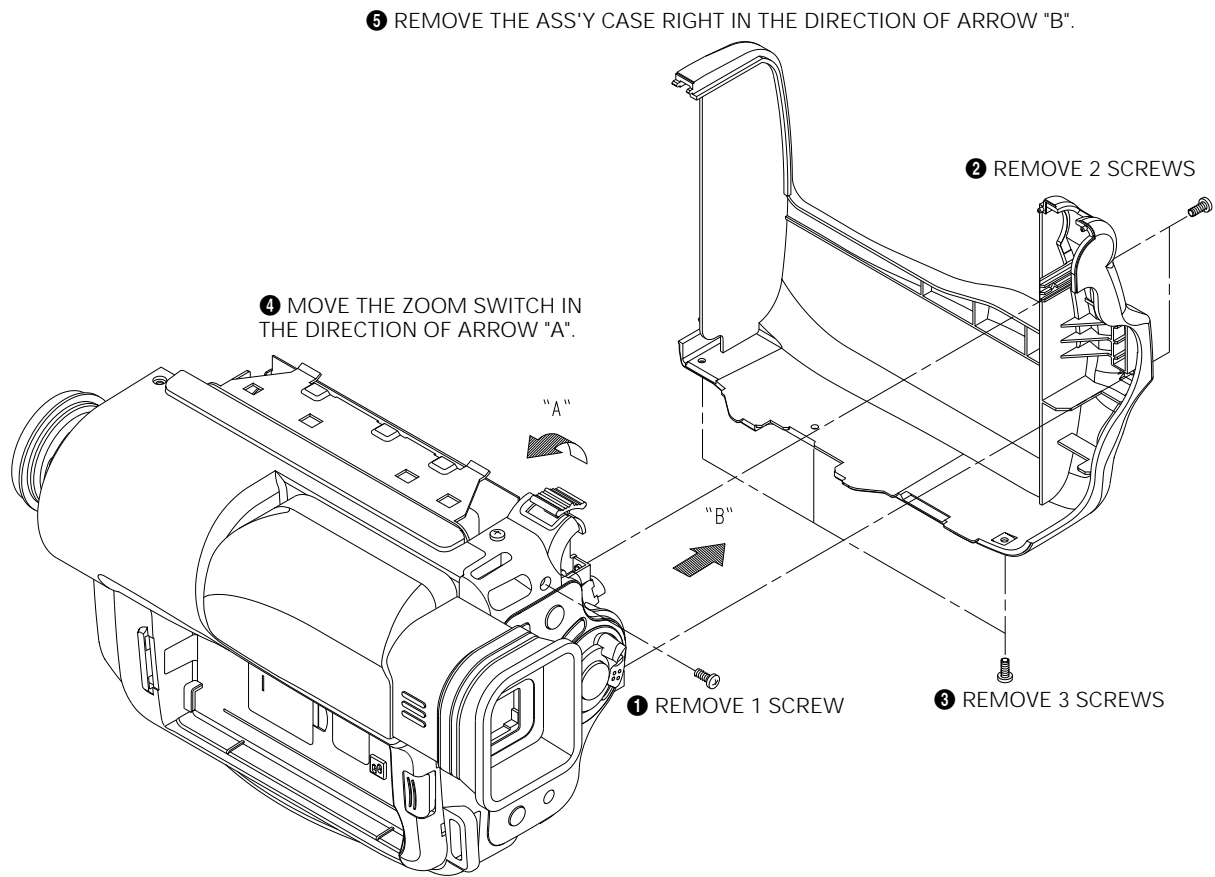

Fig. 4-6 Ass'y Case Right Removal (1)

### 4-1-7 Ass'y Case Left Removal (1)

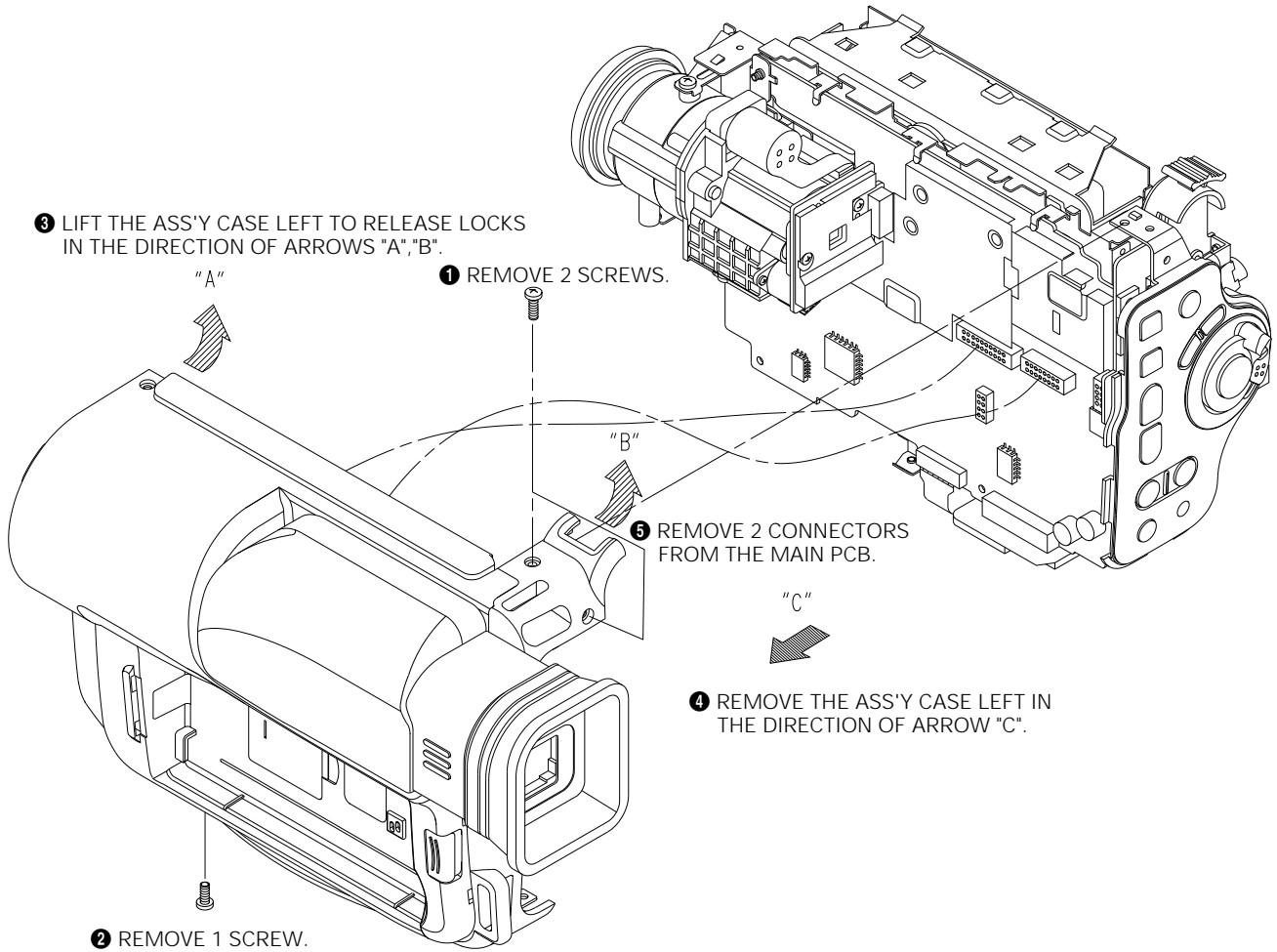

Fig. 4-7 Ass'y Case Left Removal (1)

### 4-1-8 Ass'y Case Left Removal (2)

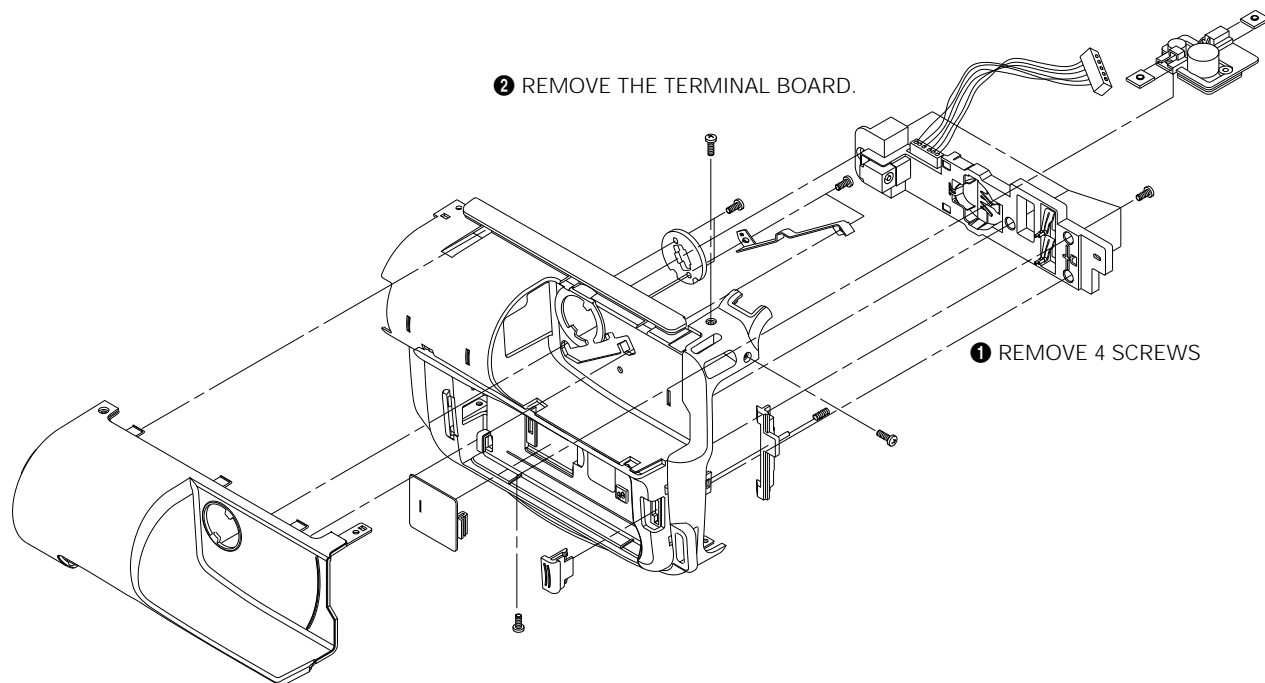

Fig. 4-8 Ass'y Case Left Removal (2)

### 4-1-9 Ass'y Rear Board Removal (1)

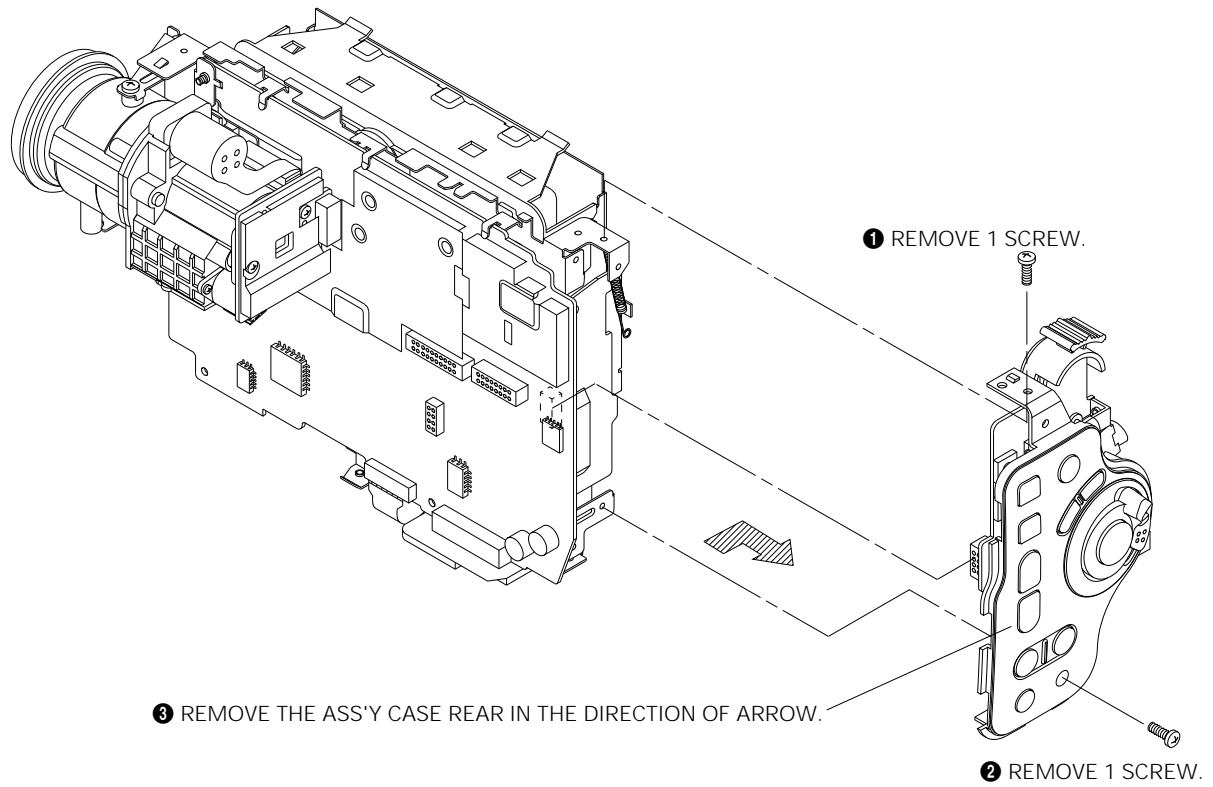

Fig. 4-9 Ass'y Rear Board Removal (1)

### 4-1-10 Ass'y Rear Board Removal (2)

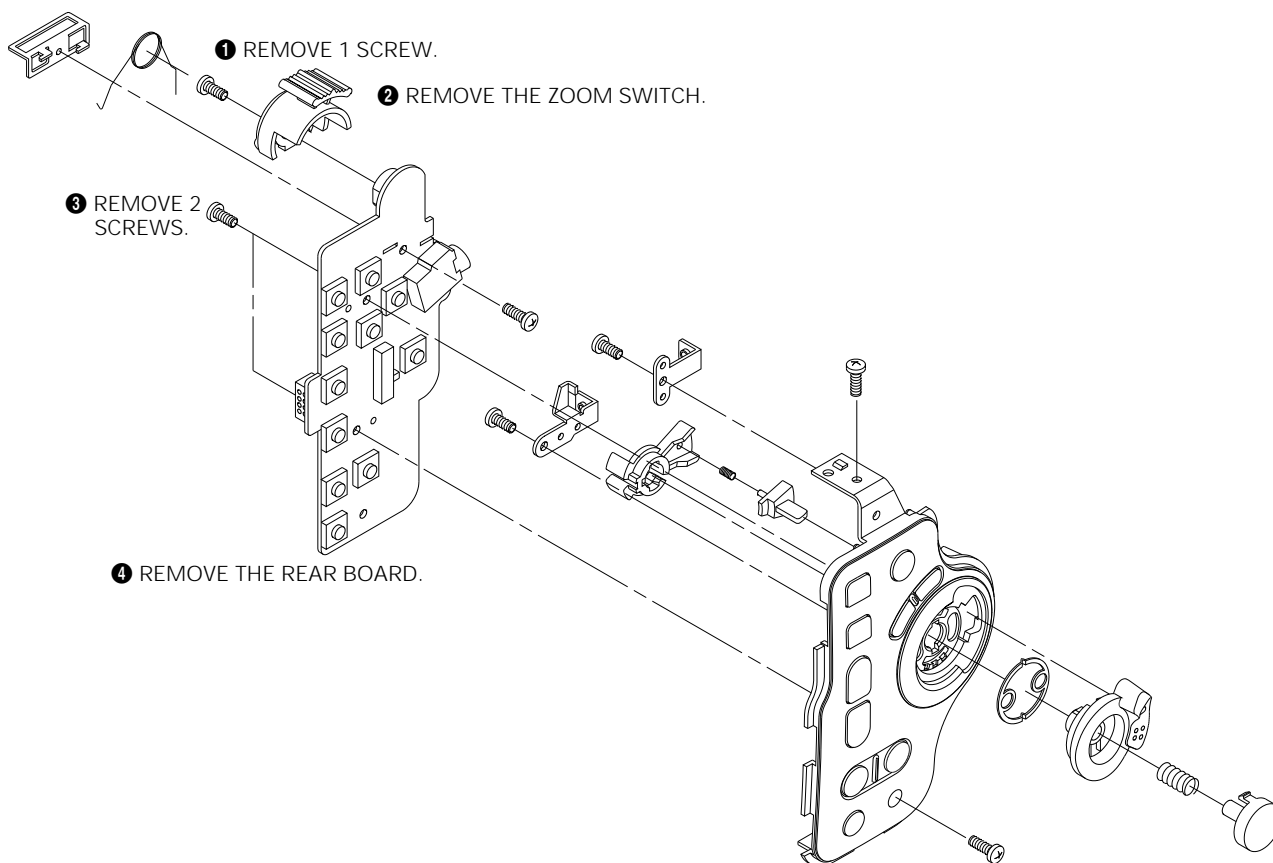

Fig. 4-10 Ass'y Rear Board Removal (2)

## 4-1-11 Ass'y Main Board and Ass'y Deck Removal

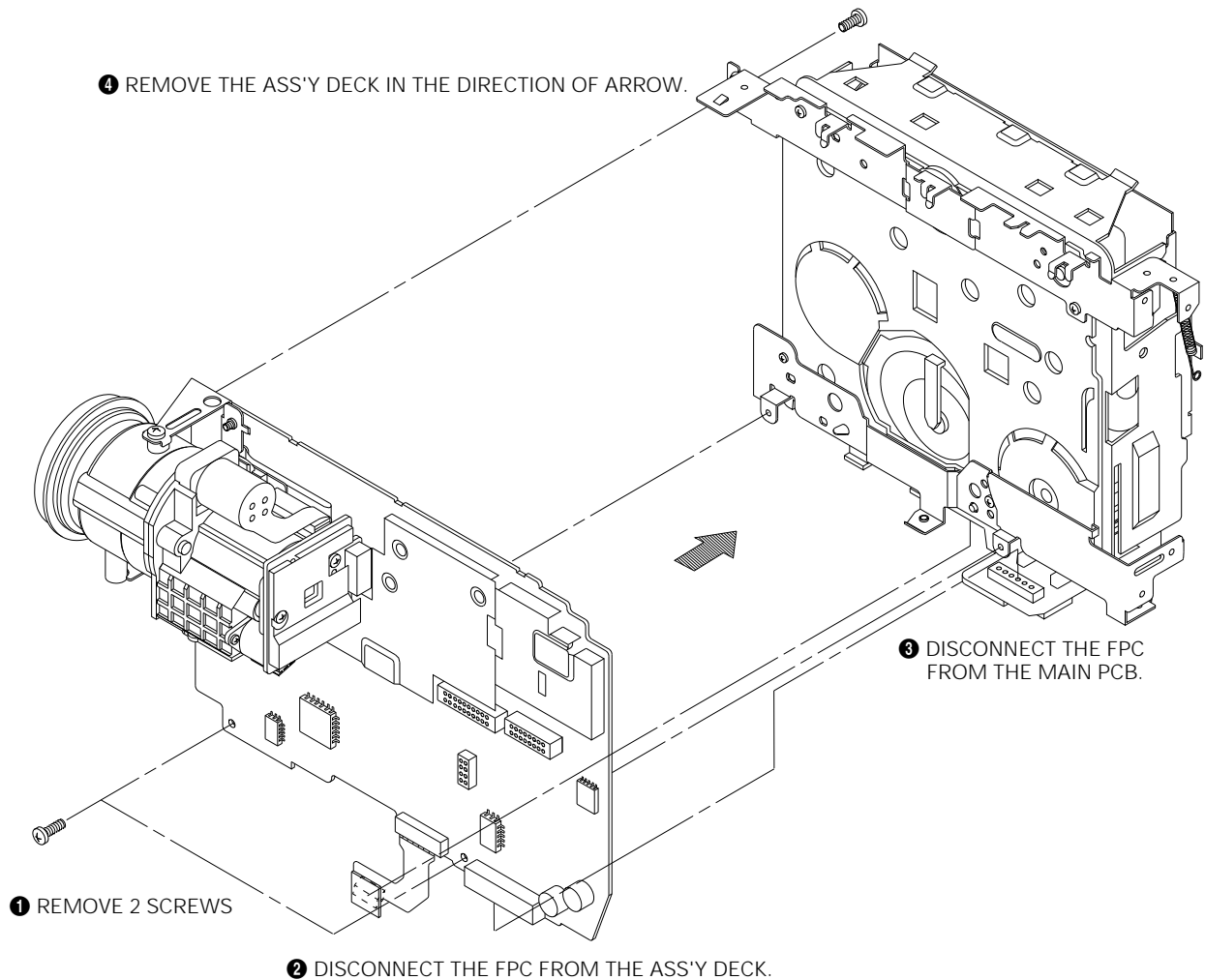

Fig. 4-11 Ass'y Main Board and Ass'y Deck Removal

### 4-1-12 Ass'y Camera Removal (1)

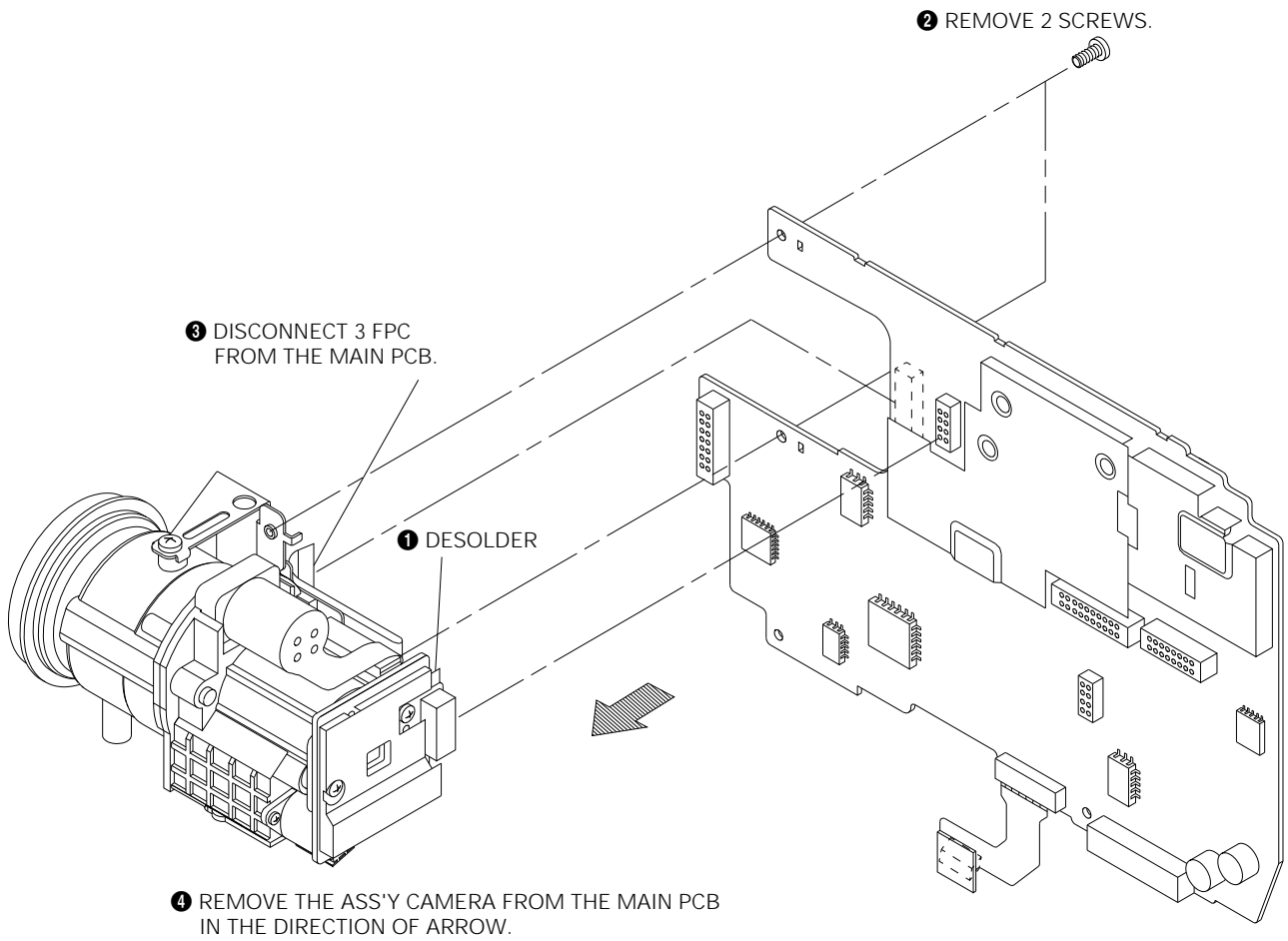

Fig. 4-12 Ass'y Camera Removal (1)

### 4-1-13 Ass'y Camera Removal (2)

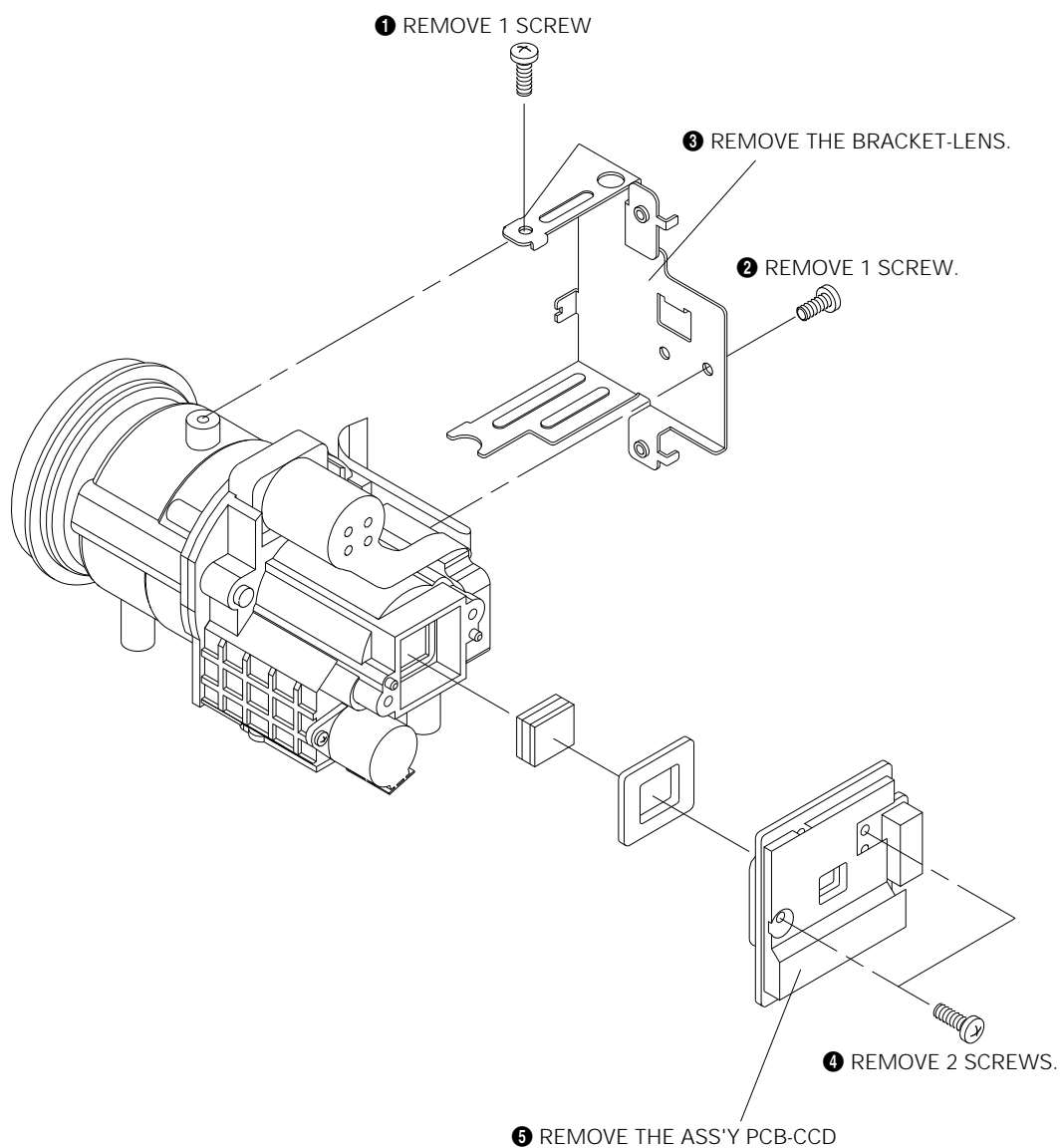

Fig. 4-13 Ass'y Camera Removal (2)

### 4-1-14 Ass'y EVF/CVF Removal

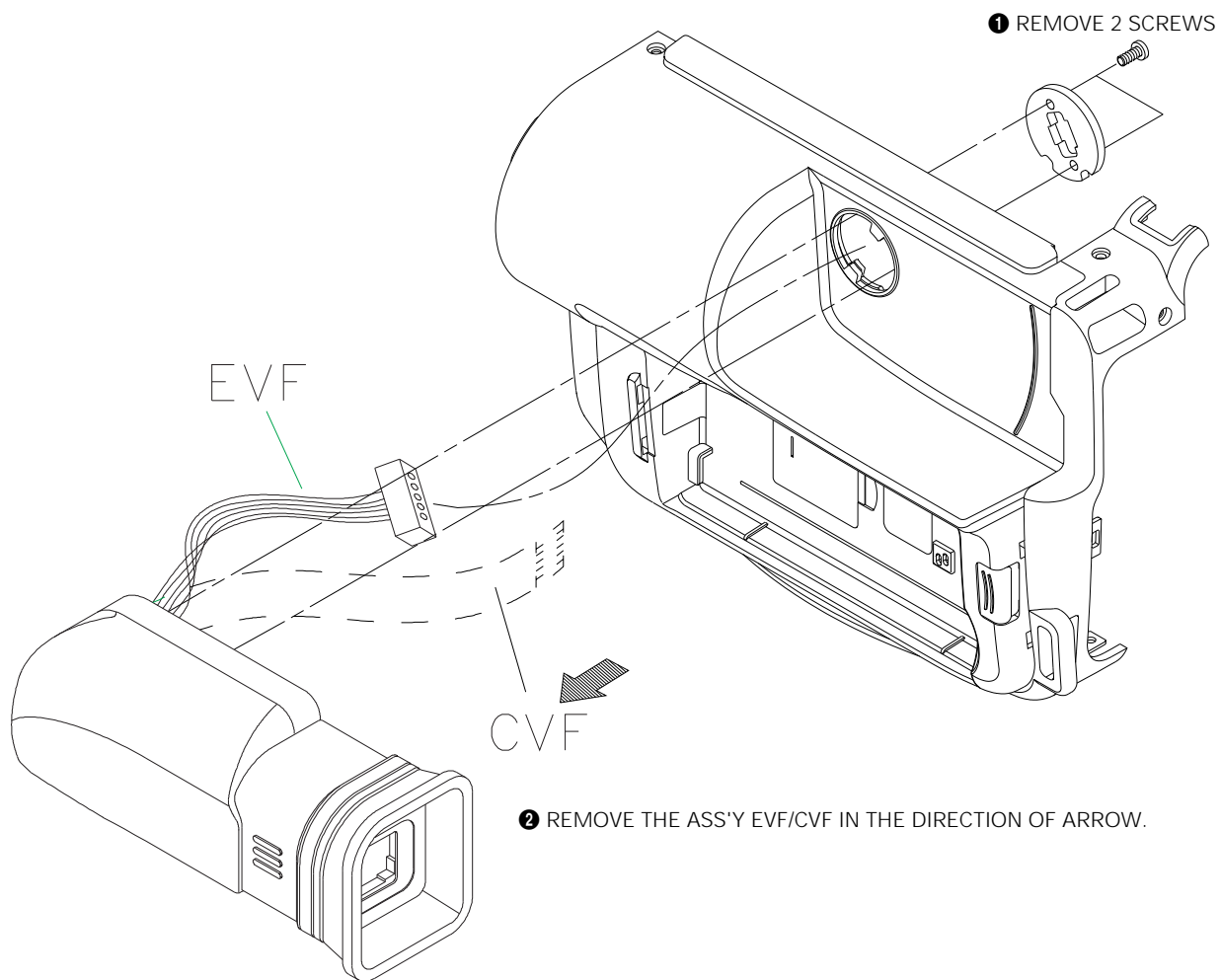

Fig. 4-14 Ass'y EVF/CVF Removal

## 4-2 Circuit Boards Location

---

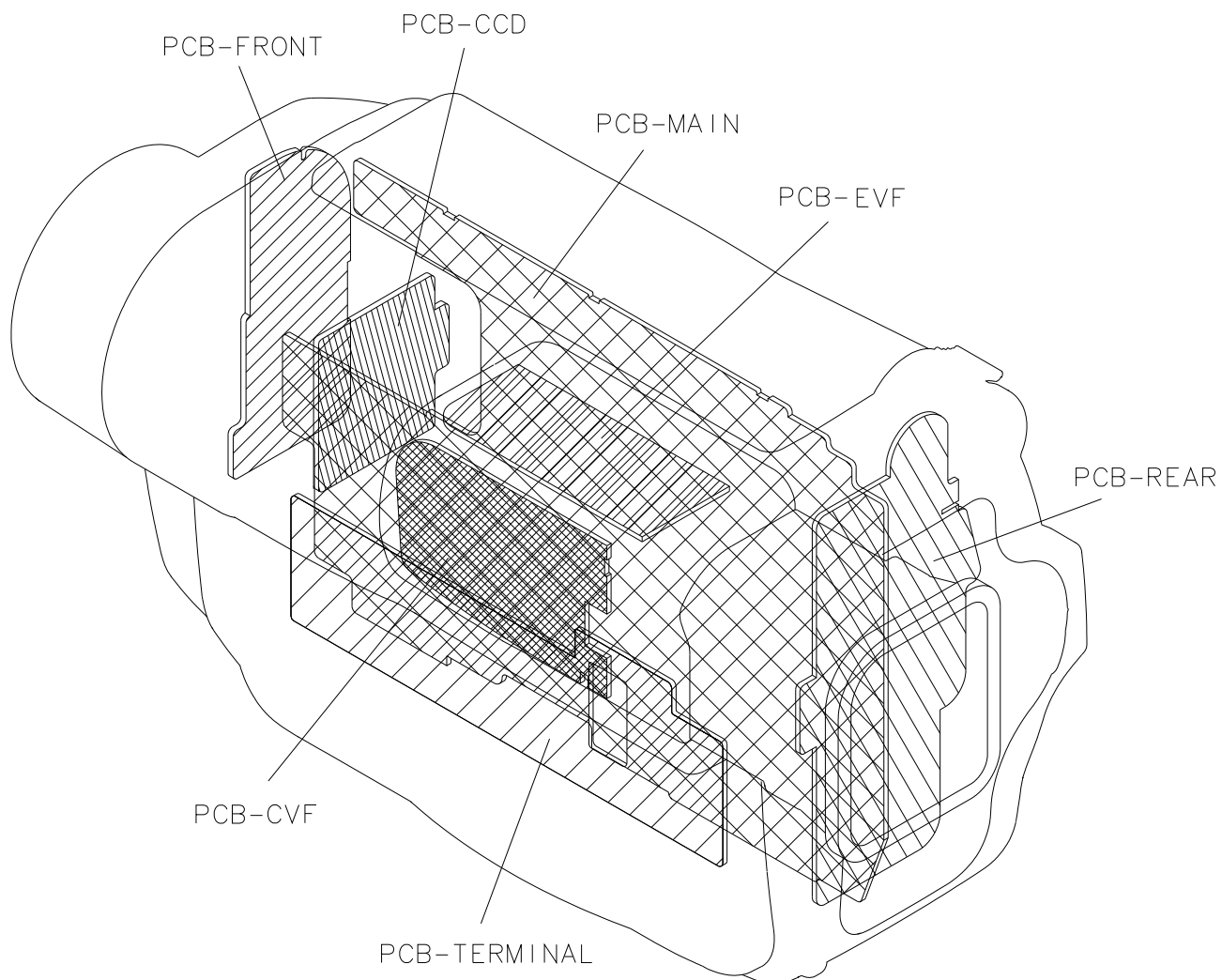
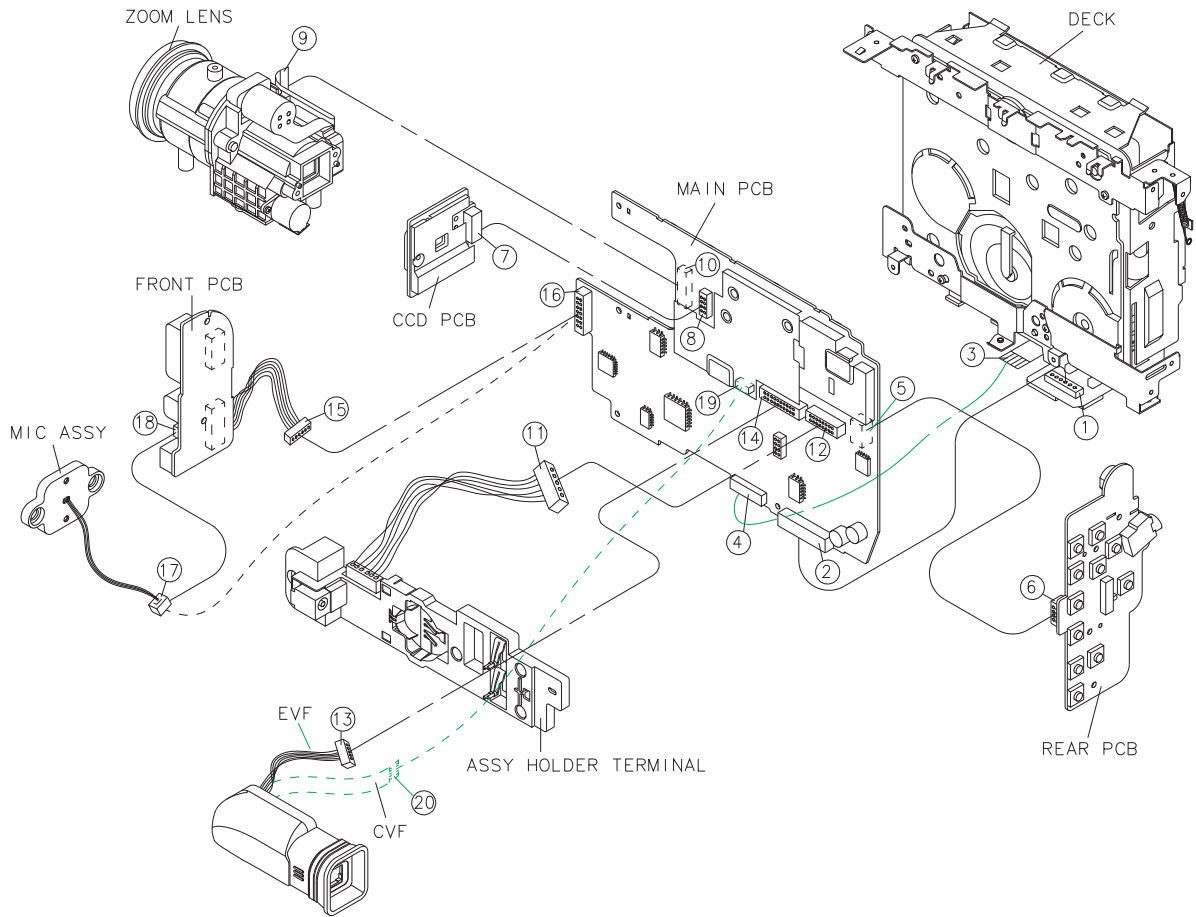

Fig. 4-15 Circuit Boards Location

### 4-3 Connector Diagrams

#### 4-3-1 Diagram(1)



NO	CONN.WAFER	DIRECTION LOCA-NO	CONN.WAFER LOCA-NO	NO.
1	W501	DECK ↔ MAIN PCB	CN501	2
3	W502	DECK ↔ MAIN PCB	CN101	4
5	CN601	MAIN PCB ↔ REAR PCB	CN851	6
7	CNC01	CCD PCB ↔ MAIN PCB	CNP01	8
9	---	LENS FPC ↔ MAIN PCB	CNP02	10
11	CN001	TERMINAL PCB ↔ MAIN PCB	CN901	12
13	CNE01	EVF ↔ MAIN PCB	CN602	14
20	CNE01	CVF ↔ MAIN PCB	CN603	19
15	CN801	FRONT PCB ↔ MAIN PCB	CN851	16
17	---	MIC ASSY ↔ FRONT PCB	CN802	18
17	---	MIC ASSY ↔ MAIN PCB	CNP03	16

Fig. 4-16 Circuit Boards Location

---

## 5. Alignment and Adjustment

---

### 5-1 Mechanical Adjustment

---

1. Refer to mechanical manual "DE-6 (AD68-30200A)" for the adjustment and checks of mechanism section.
2. Short between pin 67 of IC601 and GND in order to set the TEST mode (Track Shift Mode).
3. The location of test point (See Fig.1)

**Test Point :**

PB RF - Pin 11 of CTP501

Head Switching Trigger - Pin 9 of CTP501

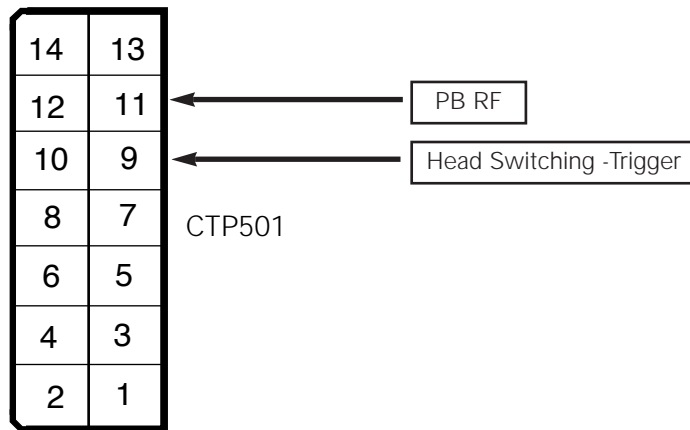

Fig. 1 Test point

4. After completing the adjustment, open the pin 67 of IC601 and GND to release the TEST mode.

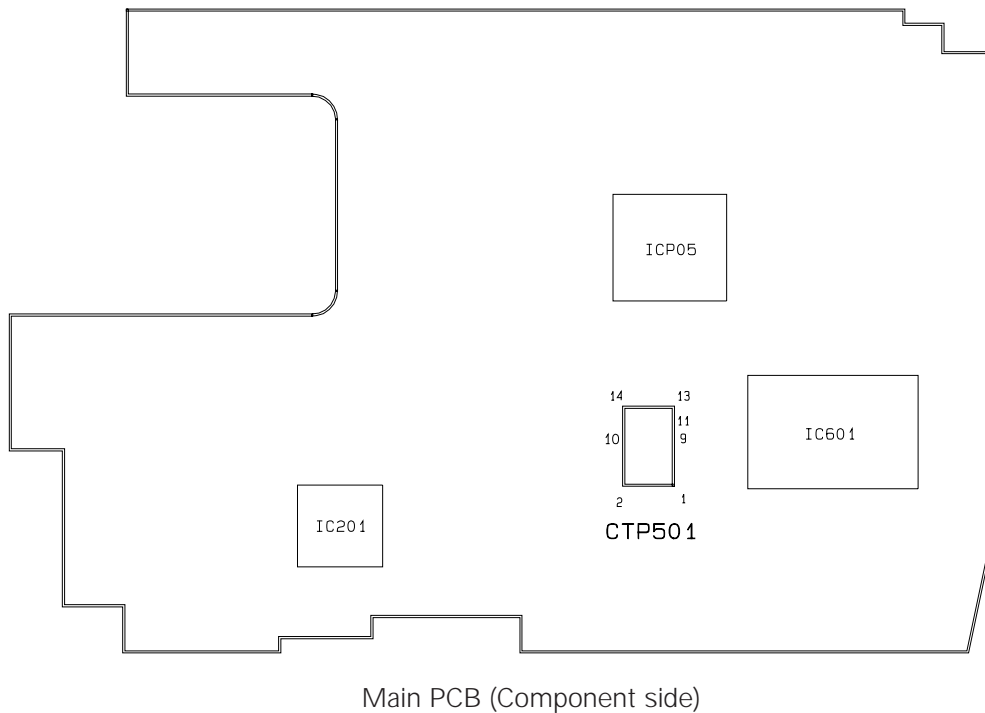

Fig. 2 The location of test point

## 5-2 Camera Section Adjustment

---

**Note :**

1. This system has
  - 1) EEPROM to store the confirmed adjustment data.
  - 2) DSP (Digital Signal Process ; ICP04 - Main board) chip to process the signal of camera parts.
  - 3) One test point for the frequency adjustment of DSP main clock (P. CLK).
2. Keep in mind
  - 1) Readjustment is needed when the EEPROM (ICP10 of Main board) is replaced.  
The reason is that EEPROM stores confirmed adjustment value of each adjustment step.

### 5-2-1 Preparations

1. Equipments to be used

- 1) DC Power supply
- 2) Oscilloscope
- 3) Frequency counter
- 4) Vectorscope
- 5) Waveform monitor
- 6) Color monitor or TV
- 7) Various charts
  - Color bar chart
  - Gray-scale chart, etc...
- 8) Alignment tape (Lion pattern)

2. Composition of camera P.C.Boards

- |             |            |
|-------------|------------|
| 1) Main PCB | 2) CCD PCB |
| 3) EVF PCB  | 4) CVF PCB |

3. Adjustment preparations

- 1) Press the confirm button when each manual adjustment step is completed to write the adjustment data to the EEPROM.
- 2) After each adjustment step is completed, OSD shows "OK!".
- 3) To cancel the adjustment mode, remove the power source.

4. Rear Board

The following is a chart explaining the use of each button :

Using Button	Adjustment
START/STOP(CONFIRM)	Data store after finishing adjustment by DATA UP/DOWN button.
- (DATA DOWN) + (DATA UP)	When changing data value of adjust state.
BLC (MODE UP) FADE (MODE DOWN)	Mode change.
DATE (FAR ) TITLE (NEAR)	Focus adjustment.

The function buttons on the Rear Board are used to control the camcorder additionally, These buttons should be used for adjustment of the camera section.

Rear Board for camcorder adjustment

Figure of button placement when Rear Board is used for service adjustment.

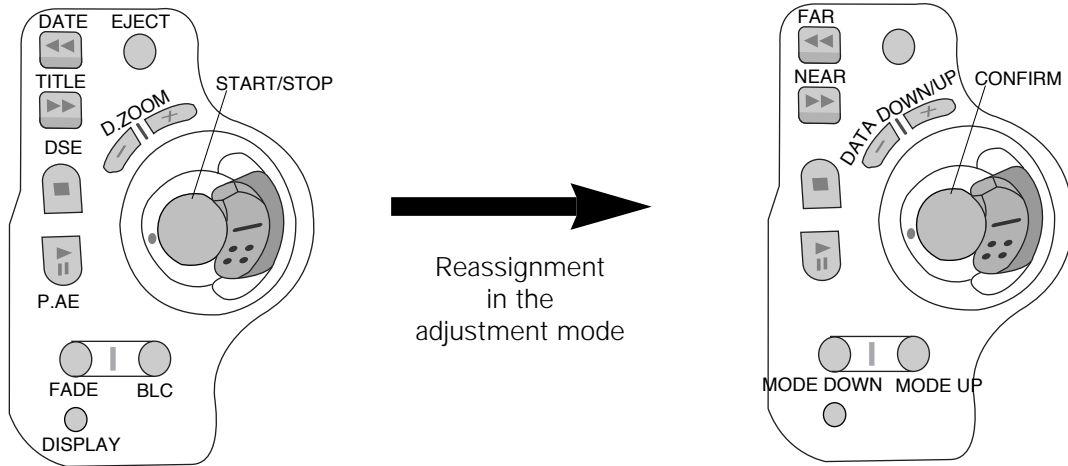

**Note :** In service adjustment mode, button names are different from those in customer camera function control mode. EX) Start/stop button is the same as confirm.

5. How to get into service “ADJUST” mode

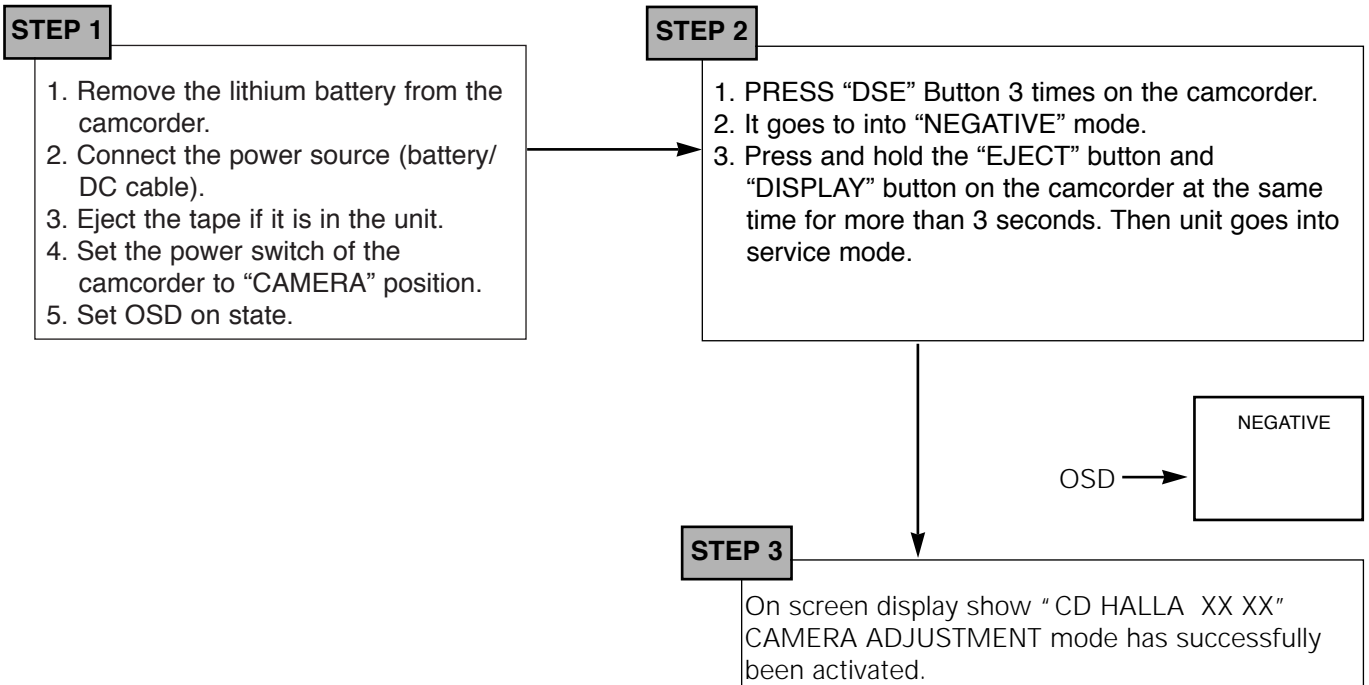

**Note :** When “XX XX” is shown in service adjustment procedures, this indicates variable values.

5. Initial data of camera parts adjustment - **CAMERA AF 1st MICOM (UPD784035GC-817) DATA**

During camera adjustment, the OSD displays the following abbreviations to indicate the selected mode.

Example) " 00 XXXX XX XX "

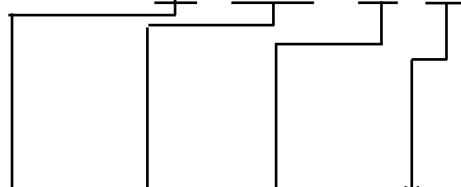

**Note :** "Data 1" is previous setting in memory, "Data 2" is now adjustment setting, that changes during adjustment mode. After pressing "START/STOP (Confirm)", it goes to memory.

MODE	OSD	VP-A20		VP-A23		NAME OF ADJUSTMENT
		DATA1	DATA2	DATA1	DATA2	
CD	HALLA	70	70	70	70	HALL AUTO ADJUSTMENT
CE	IRISA	D0	D0	D0	D0	IRIS CONTROL RANGE ADJUSTMENT
CF	WBA	FF	FF	FF	FF	WHITE BALANCE AUTO ADJUSTMENT
D0	LENSA	FF	FF	FF	FF	LENS AUTO ADJUSTMENT
D6	Z.CHK	80	80	80	80	ZOOM VR CENTER AUTO ADJUSTMENT
O3	IRIS1	70	70	70	70	IRIS LEVEL CONTROL-HIGH BYTE
O5	P.CLK	40	40	40	40	P.CLK ADJUSTMENT
O7	ADREF	00	00	00	00	A/D REFERENCE CONTROL(SETUP)
O8	S.CLP	08	08	08	08	SOFT CLIP CONTROL
O9	AGC1	18	18	18	18	AGC CONTROL
OB	HAPER	5A	5A	5A	5A	HORIZONTAL APPERTURE GAIN
OC	YSEL	FA	FA	FA	FA	VERTICAL APPERTURE GAIN
1C	CWBR	3D	3D	3D	3D	COLOR W/B COEFF. OF Cr SIGNAL
1D	CWBB	90	90	90	90	COLOR W/B COEFF. OF Cb SIGNAL
32	CRGP	47	47	47	47	INDOOR R-Y POSITIVE GAIN
33	CRGN	55	55	55	55	INDOOR R-Y NEGATIVE GAIN
34	CHYE	05	05	05	05	INDOOR R-Y POSITIVE HUE
35	CHB	10	10	10	10	INDOOR R-Y NEGATIVE HUE
36	CBGP	28	28	28	28	INDOOR B-Y POSITIVE GAIN
37	CBGN	20	20	20	20	INDOOR B-Y NEGATIVE GAIN
38	CHGR	29	29	29	29	INDOOR B-Y POSITIVE HUE
39	PCBHN	09	09	09	09	INDOOR B-Y NEGATIVE HUE
53	ECGAN	88	88	88	88	CHROMA GAIN CONTROL
54	ESY	84	84	84	84	Y SET-UP LEVEL CONTROL
55	EWC	D0	D0	D0	D0	WHITE CLIP CONTROL
57	EUSC	EF	EF	EF	EF	B-Y SIGNAL BURST LEVEL CONTROL
58	EVSC	12	12	12	12	R-Y SIGNAL BURST LEVEL CONTROL
5D	XKCON	04	04	04	04	SCK CONTROL
5E	MDSSEL	04	04	05	05	D/ZOOM MODE SELECTION
5F	TGMSE	02	02	02	02	TG MODE SELECTION
65	HRGDL	0E	0E	0E	0E	H1/H2/RG DELAY CONTROL
66	SHPD	C7	C7	C7	C7	SHP/SHD DELAY CONTROL
67	ADDL	00	00	00	00	SPO/FECKDELAY CONTROL
71	ROUGP	43	43	43	43	OUTDOOR R-Y POSITIVE GAIN
72	ROUGN	3C	3C	3C	3C	OUTDOOR R-Y NEGATIVE GAIN
73	CHOYE	01	01	01	01	OUTDOOR R-Y POSITIVE HUE
74	CHOB	1B	1B	1B	1B	OUTDOOR R-Y NEGATIVE HUE
75	GOUGP	2C	2C	2C	2C	OUTDOOR B-Y POSITIVE GAIN
76	BOUGN	25	25	25	25	OUTDOOR B-Y NEGATIVE GAIN
77	CHOGP	1C	1C	1C	1C	OUTDOOR B-Y POSITIVE HUE
78	CHOR	0C	0C	0C	0C	OUTDOOR B-Y NEGATIVE HUE
82	AETAL	A0	A0	A0	A0	AE TARGET (LOW BYTE)
83	AETAH	05	05	05	05	AE TARGET (HIGH BYTE)
88	AGCMA	85	85	85	85	AGC MAXIMUM CONTROL
8F	WBTAR	86	86	86	86	WHITE BALANCE R TARGET
90	WBTAB	74	74	74	74	WHITE BALANCE B TARGET
95	R-IN	45	45	45	45	R INDOOR CONTROL VALUE
96	B-IN	A0	A0	A0	A0	B INDOOR CONTROL VALUE
97	R-OUT	80	80	80	80	R OUTDOOR CONTROL VALUE

MODE	OSD	VP-A20		VP-A23		NAME OF ADJUSTMENT
		DATA1	DATA2	DATA1	DATA2	
98	B-OUT	68	68	68	68	B OUTDOOR CONTROL VALUE
B8	CFAPS	20	20	20	20	NOISE SLICE START AGC
B9	APNSC	FE	FE	FE	FE	NOISE SLICE MAXIMUM VALUE
BB	CFAOR	O3	O3	O3	O3	CHROMA SUPPRESS MAXIMUM VALUE
BC	BLKST	30	30	30	30	EY BLACK START AGC
BD	BLKMX	O4	O4	O4	O4	EY BLACK MAXIMUM VALUE
00		OO	OO	OO	OO	NOT USED
01		40	40	40	40	HALL GAIN
02		80	80	80	80	HALL REFERENCE
04		OO	OO	OO	OO	IRIS LEVEL CONTROL-L
06		OO	OO	OO	OO	P.CLK PWM CONTROL-L
OA		66	66	66	66	H/V BLACK NOIS THRESHOLD/GAIN
0D		13	13	13	13	APERTURE SLICE CONTROL
OE		A8	A8	A8	A8	Y HI-REF. VALUE FOR C SUPPRESS
OF		10	10	10	10	EDGE REF. VALUE FOR C SUPPRESS
10		05	05	05	05	Y SIGNAL GAMMA COEFF. 1
11		0A	0A	0A	0A	Y SIGNAL GAMMA COEFF. 2
12		1C	1C	1C	1C	Y SIGNAL GAMMA COEFF. 3
13		30	30	30	30	Y SIGNAL GAMMA COEFF. 4
14		4D	4D	4D	4D	Y SIGNAL GAMMA COEFF. 5
15		76	76	76	76	Y SIGNAL GAMMA COEFF. 6
16		BA	BA	BA	BA	Y SIGNAL GAMMA COEFF. 7
17		DA	DA	DA	DA	Y SIGNAL GAMMA COEFF. 8
18		OO	OO	OO	OO	Y LPF SELECTION
19		11	11	11	11	Cr/Cb/Y LPF SELECTION
1A		42	42	42	42	C MATRIX COEF. OF Cr SIGNAL
1B		66	66	66	66	C MATRIX COEF. OF Cb SIGNAL
1E		24	24	24	24	C W/B COEF. OF G SIGNAL
1F		05	05	05	05	C DARK SLICE COEF. OF Cr SIG.
20		00	00	00	00	C DARK SLICE COEF. OF Cb SIG.
21		FE	FE	FE	FE	C DARK SLICE COEF. OF G SIG.
22		05	05	05	05	C SIGNAL GAMMA BENDING POINT 1
23		0D	0D	0D	0D	C SIGNAL GAMMA BENDING POINT 2
24		1A	1A	1A	1A	C SIGNAL GAMMA BENDING POINT 3
25		38	38	38	38	C SIGNAL GAMMA BENDING POINT 4
26		58	58	58	58	C SIGNAL GAMMA BENDING POINT 5
27		88	88	88	88	C SIGNAL GAMMA BENDING POINT 6
28		BA	BA	BA	BA	C SIGNAL GAMMA BENDING POINT 7
29		DA	DA	DA	DA	C SIGNAL GAMMA BENDING POINT 8
2A		59	59	59	59	Cr(R-G) SIGNAL POSITIVE GAIN
2B		59	59	59	59	Cr(R-G) SIGNAL NEGATIVE GAIN
2C		F2	F2	F2	F2	Cr(B-G) SIGNAL POSITIVE GAIN
2D		F2	F2	F2	F2	Cr(B-G) SIGNAL NEGATIVE GAIN
2E		D9	D9	D9	D9	Cb(R-G) SIGNAL POSITIVE GAIN
2F		D9	D9	D9	D9	Cb(R-G) SIGNAL NEGATIVE GAIN
30		72	72	72	72	Cb(B-G) SIGNAL POSITIVE GAIN
31		72	72	72	72	Cb(B-G) SIGNAL NEGATIVE GAIN
3A		C8	C8	C8	C8	NEGA MODE W/B B CONTROL
3B		30	30	30	30	CINEMA/SPOT MODE AE TARGET
3C		35	35	35	35	R DETECT WINDOW H START POINT
3D		50	50	50	50	R DETECT WINDOW H STOP POINT
3E		3A	3A	3A	3A	R DETECT WINDOW V START POINT
3F		4B	4B	4B	4B	R DETECT WINDOW V STOP POINT
40		OO	OO	OO	OO	DSP ODM COMMEND
41		FF	FF	FF	FF	NOT USED
42		80	80	80	80	COLOR ADJUST START VALUE
43		FF	FF	FF	FF	NOT USED
44		FF	FF	FF	FF	NOT USED
45		FF	FF	FF	FF	NOT USED
46		00	00	00	00	CCD DEFECT COMPENSATION FACTOR
47		E0	E0	E0	E0	ODM AE CLIP THRESHOULD VALUE

Alignment and adjustment

MODE	OSD	VP-A20		VP-A23		NAME OF ADJUSTMENT
		DATA1	DATA2	DATA1	DATA2	
48		FF	FF	FF	FF	ODM Y UPPER VALUE OF AE MODE
49		00	00	00	00	ODM Y LOWER VALUE OF AE MODE
4A		3F	3F	3F	3F	ODM Y UPPER VALUE OF AWB MODE
4B		00	00	00	00	ODM Y LOWER VALUE OF AWB MODE
4C		FF	FF	FF	FF	R-Y THRESHOULD VALUE OF AWB MODE
4D		FF	FF	FF	FF	B-Y THRESHOULD VALUE OF AWB MODE
4E		3F	3F	3F	3F	(R-Y)+(B-Y) THRESHOULD VALUE
4F		20	20	20	20	WHITE DETECTION THRESHOULD VALUE
50		00	00	00	00	DIGITAL CLAMP OPTICAL BLACK POINT
51		01	01	01	01	Y DELAY CONTROL SELECTION
52		90	90	90	90	Y SIGNAL GAIN
56		2A	2A	2A	2A	LUMINANCE BLANK LEVEL
59		87	87	87	87	BURST FLAG DELAY SELECTION
5A		00	00	00	00	FSC/2FSC CONTROL
5B		00	00	00	00	DELAY CONTROL SELECTION
5C		3F	3F	3F	3F	DELAY CONTROL SELECTION
60		00	00	00	00	INVERSE NUMBER OF V ZOOM RATIO
61		09	09	09	09	CCD V START POINT(INTEGER LINE)
62		00	00	00	00	CCD V START POINT(SUB PIXEL)
63		83	83	83	83	SHUTTER MODE
64		FF	FF	FF	FF	HIGH SHUTTER SPEED CONTROL
68		00	00	00	00	RG/SHP PULSE WIDTH ADJUST
69		80	80	80	80	D ZOOM MODE SELECTION
6A		00	00	00	00	HORIZONTAL D ZOOM STEP
6B		00	00	00	00	VERTICAL D ZOOM STEP
6C		00	00	00	00	HORIZONTAL START READ ADDRESS -H
6D		01	01	01	01	HORIZONTAL START READ ADDRESS -L
6E		00	00	00	00	HORIZONTAL D ZOOM START SUB PIXEL
6F		00	00	00	00	V D ZOOM START SUB PIXEL ODD FIELD
70		00	00	00	00	V D ZOOM START SUB PIXEL EVEN FIELD
79		60	60	60	60	R VALUE OF SEPIA MODE
7A		18	18	18	18	G VALUE OF SEPIA MODE
7B		78	78	78	78	R VALUE OF YELLOW MODE
7C		60	60	60	60	G VALUE OF YELLOW MODE
7D		88	88	88	88	HALL REFERENSE START VALUE
7E		3A	3A	3A	3A	HALL GAIN START VALUE
7F		10	10	10	10	HALL MINIMUM VALUE (IRIS OPEN)
80		D0	D0	D0	D0	HALL MAXIMUM VALUE(IRIS CLOSE)
81		15	15	15	15	OUTDOOR DETECT IRIS CTL VALUE
84		CA	CA	CA	CA	IRIS CONTROL MIN VALUE
85		35	35	35	35	IRIS CONTROL MAX VALUE
86		02	02	02	02	TARGET MARGEIN OF IRIS ADJUST
87		12	12	12	12	NOT USED
89		FF	FF	FF	FF	NOT USED
8A		0B	0B	0B	0B	BLC ON AE TARGET
8B		30	30	30	30	CINEMA/SPOT LIGHT BLC TARGET
8C		08	08	08	08	SAND/SNOW MODE AE TARGET
8D		08	08	08	08	NEGA MODE AE TARGET
8E		FF	FF	FF	FF	NOT USED
91		45	45	45	45	R INDOOR START VALUE OF W/B ADJUST
92		85	85	85	85	B INDOOR START VALUE OF W/B ADJUST
93		65	65	65	65	R OUTDOOR START VALUE OF W/B ADJUST
94		68	68	68	68	R INDOOR START VALUE OF W/B ADJUST
99		03	03	03	03	R OUTDOOR CONTROL UP/DOWN MARGIN
9A		83	83	83	83	R INDOOR CONTROL UP/DOWN MARGIN
9B		03	03	03	03	B INDOOR CONTROL UP/DOWN MARGIN
9C		90	90	90	90	B OUTDOOR CONTROL UP/DOWN MARGIN
9D		10	10	10	10	INITIAL(POWER ON) R CTL START DATA
9E		00	00	00	00	INITIAL(POWER ON) B CTL START VALUE
9F		6E	6E	6E	6E	W/B TABLE MODE

MODE	OSD	VP-A20		VP-A23		NAME OF ADJUSTMENT
		DATA1	DATA2	DATA1	DATA2	
A0		02	02	02	02	W/B SD/3+AEAVR-MAXDETE
A1		90	90	90	90	W/B CONTROL BOUNDARY
A2		A6	A6	A6	A6	W/B CTL STOP HALL OF MACRO AREA
A3		43	43	43	43	W/B OUTDOOR STOP HALL
A4		00	00	00	00	R/B CTL SPEED UP/DOWN MODE
A5		FF	FF	FF	FF	NOT USED
A6		FF	FF	FF	FF	NOT USED
A7		20	20	20	20	W/B STABLE CONDITION
A8		FF	FF	FF	FF	NOT USED
A9		FF	FF	FF	FF	NOT USED
AA		0E	0E	0E	0E	FOCUS RESET POSITION L
AB		11	11	11	11	FOCUS RESET POSITION H
AC		4B	4B	4B	4B	ZOOM RESET POSITION L
AD		12	12	12	12	ZOOM RESET POSITION H
AE		83	83	83	83	ZOOM RESET DIFERENCE
AF		40	40	40	40	AF FILTER1 DATA MAGNIFY RATO
B0		B0	B0	B0	B0	FILTER1 NOISE LEVEL(L) OF AREA1
B1		00	00	00	00	FILTER1 NOISE LEVEL(H) OF AREA1
B2		00	00	00	00	FILTER1 NOISE LEVEL(L) OF AREA2
B3		03	03	03	03	FILTER1 NOISE LEVEL(H) OF AREA2
B4		80	80	80	80	FILTER2 NOISE LEVEL(L) OF AREA1
B5		00	00	00	00	FILTER2 NOISE LEVEL(H) OF AREA1
B6		00	00	00	00	FILTER2 NOISE LEVEL(L) OF AREA2
B7		02	02	02	02	FILTER2 NOISE LEVEL(H) OF AREA2
BA		30	30	30	30	CHROMA SUPRESS START AGC
BE		A0	A0	A0	A0	AE TAGET OF NEGA MODE(FADE IN)
BF		FF	FF	FF	FF	NOT USED
C0		2A	2A	2A	2A	FADE LIMIT OF NEGA MODE
C1		28	28	28	28	DATA CONTROL BOUNDARY OF OUTDOOR
C2		24	24	24	24	NEGA MODE W/B R-CONTROL DATA
C3		C1	C1	C1	C1	FOCUS RETURN LOW BYTE
C4		14	14	14	14	FOCUS RETURN HIGH BYTE
C5		42	42	42	42	ZOOM RETURN LOW BYTE
C6		12	12	12	12	ZOOM RETURN HIGH BYTE
C7		05	05	05	05	LENS CHECK MARGIN (WIDE)
C8		12	12	12	12	LENS CHECK MARGIN (TELE)
C9		65	65	65	65	ADJUST MODE IRIS SETTING DATA
CA		00	00	C0	C0	D ZOOM RAITO
CB		FF	FF	FF	FF	NOT USED
CC		00	00	00	00	SETUP ADJUST ENABLE
D1		FF	FF	FF	FF	HALL AUTO CHECK
D2		FF	FF	FF	FF	AGC AUTO CHECK
D3		FF	FF	FF	FF	LENS CHECK OF PCB LINE
D4		FF	FF	FF	FF	GYRO SENSOR CHECK (H)
D5		FF	FF	FF	FF	GYRO SENSOR CHECK (V)
D7		01	01	01	01	ZOOM/FOCUS CHECK ENABLE
D8		20	20	20	20	VR ZOOM CENTER MARGEIN
D9		00	00	00	00	COLOR GAIN ADJUST
DA		7E	7E	7E	7E	SETUP AUTO ADJUST
DB		08	08	08	08	HALL CHECK THRESHOULD
DC		82	82	82	82	COLOR ADJUST TARGET VALUE
DD		89	89	89	89	HALL ADJUST GAIN TARGET
DE		4D	4D	4D	4D	HALL ADJUST CENTER
DF		00	00	00	00	NOT USED
E0		FF	FF	FF	FF	NOT USED
E1		FF	FF	FF	FF	NOT USED
E2		FF	FF	FF	FF	NOT USED
E3		FF	FF	FF	FF	NOT USED
E4		FF	FF	FF	FF	NOT USED
E5		FF	FF	FF	FF	NOT USED

MODE	OSD	VP-A20		VP-A23		NAME OF ADJUSTMENT
		DATA1	DATA2	DATA1	DATA2	
E6		FF	FF	FF	FF	NOT USED
E7		FF	FF	FF	FF	NOT USED
E8		FF	FF	FF	FF	NOT USED
E9		FF	FF	FF	FF	NOT USED
EA		FF	FF	FF	FF	NOT USED
EB		FF	FF	FF	FF	NOT USED
EC		FF	FF	FF	FF	NOT USED
ED		FF	FF	FF	FF	NOT USED
EE		FF	FF	FF	FF	NOT USED
EF		FF	FF	FF	FF	NOT USED
F0		FF	FF	FF	FF	NOT USED
F1		FF	FF	FF	FF	NOT USED
F2		FF	FF	FF	FF	NOT USED
F3		FF	FF	FF	FF	NOT USED

6. Initial data of camera parts adjustment - **CAMERA AF 2nd MICOM (UPD784035GC-818) DATA**

MODE	OSD	VP-A20/A21		VP-A22		VP-A23		NAME OF ADJUSTMENT
		DATA1	DATA2	DATA1	DATA2	DATA1	DATA2	
CD	HALLA	70	70	70	70	70	70	HALL AUTO ADJUSTMENT
CE	IRISA	D0	D0	D0	D0	D0	D0	IRIS CONTROL RANGE ADJUSTMENT
CF	WBA	FF	FF	FF	FF	FF	FF	WHITE BALANCE AUTO ADJUSTMENT
D0	LENSA	FF	FF	FF	FF	FF	FF	LENS AUTO ADJUSTMENT
D6	Z.CHK	80	80	80	80	80	80	ZOOM VR CENTER AUTO ADJUSTMENT
O3	IRIS1	70	70	70	70	70	70	IRIS LEVEL CONTROL-HIGH BYTE
O5	P.CL	40	40	40	40	40	40	P.CLK ADJUSTMENT
O7	ADREF	00	00	00	00	00	00	A/D REFERENCE CONTROL(SETUP)
O8	S.CLP	08	08	08	08	08	08	SOFT CLIP CONTROL
O9	AGC1	18	18	18	18	18	18	AGC CONTROL
OB	HAPER	5A	5A	5A	5A	5A	5A	HORIZONTAL APPERTURE GAIN
OC	YSEL	FA	FA	FA	FA	FA	FA	VERTICAL APPERTURE GAIN
1C	CWBR	3D	3D	3D	3D	3D	3D	COLOR W/B COEFF. OF Cr SIGNAL
1D	CWBB	90	90	90	90	90	90	COLOR W/B COEFF. OF Cb SIGNAL
32	CRGP	47	47	47	47	47	47	INDOOR R-Y POSITIVE GAIN
33	CRGN	50	50	50	50	50	50	INDOOR R-Y NEGATIVE GAIN
34	CHYE	05	05	05	05	05	05	INDOOR R-Y POSITIVE HUE
35	CHB	08	08	08	08	08	08	INDOOR R-Y NEGATIVE HUE
36	CBGP	28	28	28	28	28	28	INDOOR B-Y POSITIVE GAIN
37	CBGN	20	20	20	20	20	20	INDOOR B-Y NEGATIVE GAIN
38	CHGR	20	20	20	20	20	20	INDOOR B-Y POSITIVE HUE
39	PCBHN	0C	0C	0C	0C	0C	0C	INDOOR B-Y NEGATIVE HUE
53	ECGAN	88	88	88	88	88	88	CHROMA GAIN CONTROL
54	ESY	83	83	83	83	83	83	Y SET-UP LEVEL CONTROL
55	EWC	D0	D0	D0	D0	D0	D0	WHITE CLIP CONTROL
57	EUSC	EF	EF	EF	EF	EF	EF	B-Y SIGNAL BURST LEVEL CONTROL
58	EVSC	12	12	12	12	12	12	R-Y SIGNAL BURST LEVEL CONTROL
5D	XKCON	04	04	04	04	04	04	SCK CONTROL
5E	MDSEL	04	04	05	05	05	05	D/ZOOM MODE SELECTION
5F	TGMSE	02	02	02	02	02	02	TG MODE SELECTION
65	HRGDL	0E	0E	0E	0E	0E	0E	H1/H2/RG DELAY CONTROL
66	SHPD	C7	C7	C7	C7	C7	C7	SHP/SHD DELAY CONTROL
67	ADDL	00	00	00	00	00	00	SPO/FECKDELAY CONTROL
71	ROUGP	47	47	47	47	47	47	OUTDOOR R-Y POSITIVE GAIN
72	ROUGN	48	48	48	48	48	48	OUTDOOR R-Y NEGATIVE GAIN
73	CHOYE	05	05	05	05	05	05	OUTDOOR R-Y POSITIVE HUE
74	CHOB	15	15	15	15	15	15	OUTDOOR R-Y NEGATIVE HUE
75	GOUGP	2C	2C	2C	2C	2C	2C	OUTDOOR B-Y POSITIVE GAIN
76	BOUGN	25	25	25	25	25	25	OUTDOOR B-Y NEGATIVE GAIN
77	CHOGR	20	20	20	20	20	20	OUTDOOR B-Y POSITIVE HUE

MODE	OSD	VP-A20/A21		VP-A22		VP-A23		NAME OF ADJUSTMENT
		DATA1	DATA2	DATA1	DATA2	DATA1	DATA2	
78	CHOR	0C	0C	0C	0C	0C	0C	OUTDOOR B-Y NEGATIVE HUE
82	AETAL	80	80	80	80	80	80	AE TARGET (LOW BYTE)
83	AETAH	05	05	05	05	05	05	AE TARGET (HIGH BYTE)
88	AGCMA	85	85	85	85	85	85	AGC MAXIMUM CONTROL
8F	WB TAR	86	86	86	86	86	86	WHITE BALANCE R TARGET
90	WB TAB	74	74	74	74	74	74	WHITE BALANCE B TARGET
95	R-IN	45	45	45	45	45	45	R INDOOR CONTROL VALUE
96	B-IN	A0	A0	A0	A0	A0	A0	B INDOOR CONTROL VALUE
97	R-OUT	80	80	80	80	80	80	R OUTDOOR CONTROL VALUE
98	B-OUT	68	68	68	68	68	68	B OUTDOOR CONTROL VALUE
B8	CFAPS	20	20	20	20	20	20	NOISE SLICE START AGC
B9	APNSC	FE	FE	FE	FE	FE	FE	NOISE SLICE MAXIMUM VALUE
BB	CFAOR	03	03	03	03	03	03	CHROMA SUPPRESS MAXIMUM VALUE
BC	BLKST	30	30	30	30	30	30	EY BLACK START AGC
BD	BLKMX	04	04	04	04	04	04	EY BLACK MAXIMUM VALUE
00		00	00	00	00	00	00	NOT USED
01		40	40	40	40	40	40	HALL GAIN
02		80	80	80	80	80	80	HALL REFERENCE
04		00	00	00	00	00	00	IRIS LEVEL CONTROL-L
06		00	00	00	00	00	00	P.CLK PWM CONTROL-L
0A		66	66	66	66	66	66	H/V BLACK NOIS THRESHOLD/GAIN
0D		13	13	13	13	13	13	APERTURE SLICE CONTROL
0E		A8	A8	A8	A8	A8	A8	Y HI-REF. VALUE FOR C SUPPRESS
0F		10	10	10	10	10	10	EDGE REF. VALUE FOR C SUPPRESS
10		05	05	05	05	05	05	Y SIGNAL GAMMA COEFF. 1
11		0A	0A	0A	0A	0A	0A	Y SIGNAL GAMMA COEFF. 2
12		1C	1C	1C	1C	1C	1C	Y SIGNAL GAMMA COEFF. 3
13		30	30	30	30	30	30	Y SIGNAL GAMMA COEFF. 4
14		4D	4D	4D	4D	4D	4D	Y SIGNAL GAMMA COEFF. 5
15		76	76	76	76	76	76	Y SIGNAL GAMMA COEFF. 6
16		BA	BA	BA	BA	BA	BA	Y SIGNAL GAMMA COEFF. 7
17		DA	DA	DA	DA	DA	DA	Y SIGNAL GAMMA COEFF. 8
18		00	00	00	00	00	00	Y LPF SELECTION
19		11	11	11	11	11	11	Cr/Cb/Y LPF SELECTION
1A		42	42	42	42	42	42	C MATRIX COEF. OF Cr SIGNAL
1B		66	66	66	66	66	66	C MATRIX COEF. OF Cb SIGNAL
1E		24	24	24	24	24	24	C W/B COEF. OF G SIGNAL
1F		05	05	05	05	05	05	C DARK SLICE COEF. OF Cr SIG.
20		00	00	00	00	00	00	C DARK SLICE COEF. OF Cb SIG.
21		FE	FE	FE	FE	FE	FE	C DARK SLICE COEF. OF G SIG.
22		05	05	05	05	05	05	C SIGNAL GAMMA BENDING POINT 1
23		0D	0D	0D	0D	0D	0D	C SIGNAL GAMMA BENDING POINT 2
24		1A	1A	1A	1A	1A	1A	C SIGNAL GAMMA BENDING POINT 3
25		38	38	38	38	38	38	C SIGNAL GAMMA BENDING POINT 4
26		58	58	58	58	58	58	C SIGNAL GAMMA BENDING POINT 5
27		88	88	88	88	88	88	C SIGNAL GAMMA BENDING POINT 6
28		BA	BA	BA	BA	BA	BA	C SIGNAL GAMMA BENDING POINT 7
29		DA	DA	DA	DA	DA	DA	C SIGNAL GAMMA BENDING POINT 8
2A		59	59	59	59	59	59	Cr(R-G) SIGNAL POSITIVE GAIN
2B		59	59	59	59	59	59	Cr(R-G) SIGNAL NEGATIVE GAIN
2C		F2	F2	F2	F2	F2	F2	Cr(B-G) SIGNAL POSITIVE GAIN
2D		F2	F2	F2	F2	F2	F2	Cr(B-G) SIGNAL NEGATIVE GAIN
2E		D9	D9	D9	D9	D9	D9	Cb(R-G) SIGNAL POSITIVE GAIN
2F		D9	D9	D9	D9	D9	D9	Cb(R-G) SIGNAL NEGATIVE GAIN
30		72	72	72	72	72	72	Cb(B-G) SIGNAL POSITIVE GAIN
31		72	72	72	72	72	72	Cb(B-G) SIGNAL NEGATIVE GAIN
3A		C8	C8	C8	C8	C8	C8	NEGA MODE W/B B CONTROL
3B		30	30	30	30	30	30	CINEMA/SPOT MODE AE TARGET
3C		35	35	35	35	35	35	R DETECT WINDOW H START POINT
3D		50	50	50	50	50	50	R DETECT WINDOW H STOP POINT
3E		3A	3A	3A	3A	3A	3A	R DETECT WINDOW V START POINT

Alignment and adjustment

MODE	OSD	VP-A20/A21		VP-A22		VP-A23		NAME OF ADJUSTMENT
		DATA1	DATA2	DATA1	DATA2	DATA1	DATA2	
3F		4B	4B	4B	4B	4B	4B	R DETECT WINDOW V STOP POINT
40		00	00	00	00	00	00	DSP ODM COMMEND
41		70	70	70	70	70	70	CLIP COUNTER THRESHOULD
42		80	80	80	80	80	80	COLOR ADJUST START VALUE
43		00	00	85	85	88	88	R TARGET UP/DOWN OF D ZOOM
44		00	00	00	00	00	00	B TARGET UP/DOWN OF D ZOOM
45		FF	FF	FF	FF	FF	FF	SHUTTER OF D ZOOM
46		00	00	00	00	00	00	CCD DEFECT COMPENSATION FACTOR
47		F0	F0	F0	F0	F0	F0	ODM AE CLIP THRESHOULD VALUE
48		FF	FF	FF	FF	FF	FF	ODM Y UPPER VALUE OF AE MODE
49		00	00	00	00	00	00	ODM Y LOWER VALUE OF AE MODE
4A		3F	3F	3F	3F	3F	3F	ODM Y UPPER VALUE OF AWB MODE
4B		00	00	00	00	00	00	ODM Y LOWER VALUE OF AWB MODE
4C		FF	FF	FF	FF	FF	FF	R-Y THRESHOULD VALUE OF AWB MODE
4D		FF	FF	FF	FF	FF	FF	B-Y THRESHOULD VALUE OF AWB MODE
4E		3F	3F	3F	3F	3F	3F	(R-Y)+(B-Y) THRESHOULD VALUE
4F		20	20	20	20	20	20	WHITE DETECTION THRESHOULD VALUE
50		00	00	00	00	00	00	DIGITAL CLAMP OPTICAL BLACK POINT
51		01	01	01	01	01	01	Y DELAY CONTROL SELECTION
52		98	98	98	98	98	98	Y SIGNAL GAIN
56		2A	2A	2A	2A	2A	2A	LUMINANCE BLANK LEVEL
59		87	87	87	87	87	87	BURST FLAG DELAY SELECTION
5A		00	00	00	00	00	00	FSC/2FSC CONTROL
5B		00	00	00	00	00	00	DELAY CONTROL SELECTION
5C		3F	3F	3F	3F	3F	3F	DELAY CONTROL SELECTION
60		00	00	00	00	00	00	INVERSE NUMBER OF V ZOOM RATIO
61		0C	0C	0C	0C	0C	0C	CCD V START POINT(INTEGER LINE)
62		00	00	00	00	00	00	CCD V START POINT(SUB PIXEL)
63		83	83	83	83	83	83	SHUTTER MODE
64		FF	FF	FF	FF	FF	FF	HIGH SHUTTER SPEED CONTROL
68		00	00	00	00	00	00	RG/SHP PULSE WIDTH ADJUST
69		80	80	80	80	80	80	D ZOOM MODE SELECTION
6A		00	00	00	00	00	00	HORIZONTAL D ZOOM STEP
6B		00	00	00	00	00	00	VERTICAL D ZOOM STEP
6C		00	00	00	00	00	00	HORIZONTAL START READ ADDRESS -H
6D		01	01	01	01	01	01	HORIZONTAL START READ ADDRESS -L
6E		00	00	00	00	00	00	HORIZONTAL D ZOOM START SUB PIXEL
6F		00	00	00	00	00	00	V D ZOOM START SUB PIXEL ODD FIELD
70		00	00	00	00	00	00	V D ZOOM START SUB PIXEL EVEN FIELD
79		48	48	48	48	48	48	R VALUE OF SEPIA MODE
7A		20	20	20	20	20	20	G VALUE OF SEPIA MODE
7B		78	78	78	78	78	78	R VALUE OF YELLOW MODE
7C		60	60	60	60	60	60	G VALUE OF YELLOW MODE
7D		88	88	88	88	88	88	HALL REFERENSE START VALUE
7E		3A	3A	3A	3A	3A	3A	HALL GAIN START VALUE
7F		10	10	10	10	10	10	HALL MINIMUM VALUE (IRIS OPEN)
80		D0	D0	D0	D0	D0	D0	HALL MAXIMUM VALUE(IRIS CLOSE)
81		18	18	18	18	18	18	OUTDOOR DETECT IRIS CTL VALUE
84		CA	CA	CA	CA	CA	CA	IRIS CONTROL MIN VALUE
85		35	35	35	35	35	35	IRIS CONTROL MAX VALUE
86		02	02	02	02	02	02	TARGET MARGEIN OF IRIS ADJUST
87		12	12	12	12	12	12	DIGITAL CLAMP CCD
89		10	10	10	10	10	10	NOT USED
8A		0B	0B	0B	0B	0B	0B	BLC ON AE TARGET
8B		40	40	40	40	40	40	CINEMA/SPOT LIGHT BLC TARGET
8C		08	08	08	08	08	08	SAND/SNOW MODE AE TARGET
8D		08	08	08	08	08	08	NEGA MODE AE TARGET
8E		0A	0A	0A	0A	0A	0A	NOT USED
91		45	45	45	45	45	45	R INDOOR START VALUE OF W/B ADJUST
92		85	85	85	85	85	85	B INDOOR START VALUE OF W/B ADJUST
93		65	65	65	65	65	65	R OUTDOOR START VALUE OF W/B ADJUST

MODF	OSD	VP-A20/A21		VP-A22		VP-A23		NAME OF ADJUSTMENT
		DATA1	DATA2	DATA1	DATA2	DATA1	DATA2	
94		68	68	68	68	68	68	R INDOOR START VALUE OF W/B ADJUST
99		02	02	02	02	02	02	R OUTDOOR CONTROL UP/DOWN MARGIN
9A		83	83	83	83	83	83	R INDOOR CONTROL UP/DOWN MARGIN
9B		03	03	03	03	03	03	B INDOOR CONTROL UP/DOWN MARGIN
9C		8A	8A	8A	8A	8A	8A	B OUTDOOR CONTROL UP/DOWN MARGIN
9D		00	00	00	00	00	00	INITIAL(POWER ON) R CTL START DATA
9E		00	00	00	00	00	00	INITIAL(POWER ON) B CTL START VALUE
9F		6E	6E	6E	6E	6E	6E	W/B TABLE MODE
A0		02	02	02	02	02	02	W/B SD/3+AEAVR-MAXDETE
A1		90	90	90	90	90	90	W/B CONTROL BOUNDARY
A2		A6	A6	A6	A6	A6	A6	W/B CTL STOP HALL OF MACRO AREA
A3		48	48	48	48	48	48	W/B OUTDOOR STOP HALL
A4		00	00	00	00	00	00	R/B CTL SPEED UP/DOWN MODE
A5		40	40	40	40	40	40	V NOISE THRESHOULD OF EIS
A6		00	00	00	00	00	00	H NOISE THRESHOULD OF EIS
A7		20	20	20	20	20	20	W/B STABLE CONDITION
A8		00	00	05	05	05	05	R CONTROL UP/DOWN OF D ZOOM
A9		00	00	05	05	05	05	B CONTROL UP/DOWN OF D ZOOM
AA		0E	0E	0E	0E	0E	0E	FOCUS RESET POSITION L
AB		11	11	11	11	11	11	FOCUS RESET POSITION H
AC		4B	4B	4B	4B	4B	4B	ZOOM RESET POSITION L
AD		12	12	12	12	12	12	ZOOM RESET POSITION H
AE		83	83	83	83	83	83	ZOOM RESET DIFERENCE
AF		40	40	40	40	40	40	AF FILTER1 DATA MAGNIFY RATO
B0		B0	B0	B0	B0	B0	B0	FILTER1 NOISE LEVEL(L) OF AREA1
B1		00	00	00	00	00	00	FILTER1 NOISE LEVEL(H) OF AREA1
B2		00	00	00	00	00	00	FILTER1 NOISE LEVEL(L) OF AREA2
B3		03	03	03	03	03	03	FILTER1 NOISE LEVEL(H) OF AREA2
B4		80	80	80	80	80	80	FILTER2 NOISE LEVEL(L) OF AREA1
B5		00	00	00	00	00	00	FILTER2 NOISE LEVEL(H) OF AREA1
B6		00	00	00	00	00	00	FILTER2 NOISE LEVEL(L) OF AREA2
B7		02	02	02	02	02	02	FILTER2 NOISE LEVEL(H) OF AREA2
BA		30	30	30	30	30	30	CHROMA SUPPRESS START AGC
BE		A0	A0	A0	A0	A0	A0	AE TAgET OF NEGA MODE(FADE IN)
BF		66	66	66	66	66	66	H/V ADJUST OF D ZOOM HEADER COMMEND
C0		2A	2A	2A	2A	2A	2A	FADE LIMIT OF NEGA MODE
C1		28	28	28	28	28	28	DATA CONTROL BOUNDARY OF OUTDOOR
C2		24	24	24	24	24	24	NEGA MODE W/B R-CONTROL DATA
C3		A1	A1	A1	A1	A1	A1	FOCUS RETURN LOW BYTE
C4		15	15	15	15	15	15	FOCUS RETURN HIGH BYTE
C5		A0	A0	A0	A0	A0	A0	ZOOM RETURN LOW BYTE
C6		12	12	12	12	12	12	ZOOM RETURN HIGH BYTE
C7		05	05	05	05	05	05	LENS CHECK MARGIN (WIDE)
C8		12	12	12	12	12	12	LENS CHECK MARGIN (TELE)
C9		65	65	65	65	65	65	ADJUST MODE IRIS SETTING DATA
CA		7F	7F	7F	7F	7F	7F	D ZOOM RAITO
CB		06	06	06	06	06	06	AE UP/DOWN OF NEGA MODE BLC
CC		00	00	00	00	00	00	SETUP ADJUST ENABLE
D1		FF	FF	FF	FF	FF	FF	HALL AUTO CHECK
D2		FF	FF	FF	FF	FF	FF	AGC AUTO CHECK
D3		FF	FF	FF	FF	FF	FF	LENS CHECK OF PCB LINE
D4		FF	FF	FF	FF	FF	FF	GYRO SENSOR CHECK (H)
D5		FF	FF	FF	FF	FF	FF	GYRO SENSOR CHECK (V)
D7		01	01	01	01	01	01	ZOOM/FOCUS CHECK ENABLE
D8		20	20	20	20	20	20	VR ZOOM CENTER MARGEIN
D9		00	00	00	00	00	00	COLOR GAIN ADJUST
DA		7E	7E	7E	7E	7E	7E	SETUP AUTO ADJUST
DB		08	08	08	08	08	08	HALL CHECK THRESHOULD
DC		82	82	82	82	82	82	COLOR ADJUST TARGET VALUE
DD		89	89	89	89	89	89	HALL ADJUST GAIN TARGET
DE		4D	4D	4D	4D	4D	4D	HALL ADJUST CENTER

Alignment and adjustment

MODE	OSD	VP-A20/A21		VP-A22		VP-A23		NAME OF ADJUSTMENT
		DATA1	DATA2	DATA1	DATA2	DATA1	DATA2	
DF		00	00	00	00	00	00	NOT USED
E0		AA	AA	AA	AA	AA	AA	BK NOISE TH/GAIN OF EIS
E1		5F	5F	5F	5F	5F	5F	H APPERTURE GAIN OF EIS
E2		FF	FF	FF	FF	FF	FF	#0C OF EIS ON
E3		0B	0B	0B	0B	0B	0B	#0D OF EIS ON
E4		A8	A8	A8	A8	A8	A8	#0E OF EIS ON
E5		10	10	10	10	10	10	#0F OF EIS ON
E6		00	00	00	00	00	00	#18 OF EIS ON
E7		01	01	01	01	01	01	EIS DEMO
E8		69	69	69	69	69	69	V GAIN-1(A/D GAIN)
E9		08	08	08	08	08	08	V GAIN-2(CCD GAIN)
EA		EB	EB	EB	EB	EB	EB	V GAIN-3(CENTERING GAIN)
EB		08	08	08	08	08	08	V STOP NOISE THRESHOULD
EC		8C	8C	8C	8C	8C	8C	H GAIN-1(A/D GAIN)
ED		08	08	08	08	08	08	H GAIN-2(CCD GAIN)
EE		EB	EB	EB	EB	EB	EB	H GAIN-3(CENTERING GAIN)
EF		09	09	09	09	09	09	H STOP NOISE THRESHOULD
F0		00	00	00	00	00	00	D-ZOOM STEP
F1		01	01	01	01	01	01	NOT USED
F2		80	80	80	80	80	80	R TARGET OF W/B ADJUST
F3		80	80	80	80	80	80	B TARGET OF W/B ADJUST

**Note :** On table you see the “XX XX” for DATA 1/DATA 2  
 “XX XX” means arbitrary value.

<Example of the TV screen>

CD	HALLA	<u>XX</u>	<u>XX</u>
		Data in memory	Data to be adjusted

## 5-2-2 Camera System Adjustment

**Note :** From now on, the structure of every adjustment is as follows.

Step	Adjustment Item
1)	Mode and input signal/ alignment tape
2)	Test point and ADJ. part
3)	And after Result and Remarks

**Note :** The on-screen display information.

“XX XX” means arbitrary value.

It can be different number depend on the conditions.

CD	HALLA	XX	XX
----	-------	----	----

### 1. Focus to zoom tracking

**Note :** To maintain proper focus throughout the zoom range, the focus lens position must be changed as the zoom lens is moved.

During this adjustment the microprocessor will measure the focus positioning requirements at the wide and telephoto position of the zoom lens.

- 1) Camera “E-E”.
- 2) Focus chart (Attached on the last page of this manual).
- 3) Aim the camera at the focus chart placed about 30ft. (8 to 10 meters) away and perpendicular to the center of the lens.

The chart should be placed on the flat, gray or white wall.

- 4) Connect monitor TV jack to video output jack.
- 5) Press the “BLC (MODE UP)” and “FADE (MODE DOWN)” button, so that the OSD start is “DO LENZA XX XX”.
- 6) Focus adjustment

- a. Full auto : Press “START/STOP (CONFIRM)” button for full auto adjustment.

The camera will move both zoom and focus lens.

The adjustment is finished when the O.K! message appears on the TV screen.

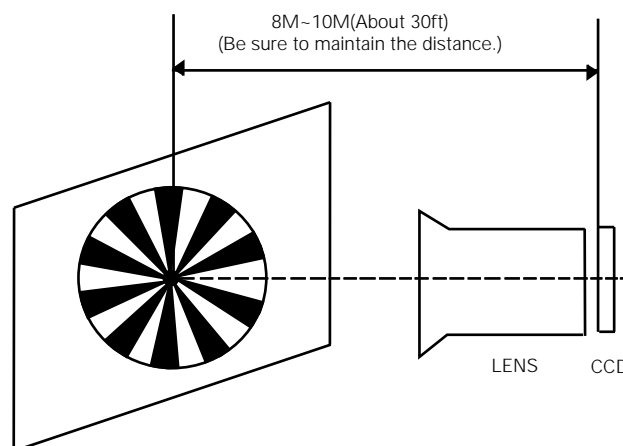

## 2. P. CLK Adjustment

- 1) "Camera", no signal input.
- 2) P.CLK and AF MICOM.
- 3) Connect a frequency counter to P.CLK.
- 4) Press the "BLC (MODE UP)/FADE (MODE DOWN)" button so that the OSD state is "05 P.CLK XX XX".
- 5) Adjust the "+ (DATA UP)/ - (DATA DOWN)" button so that frequency is  $9.453125\text{MHz} \pm 50\text{Hz}$ .

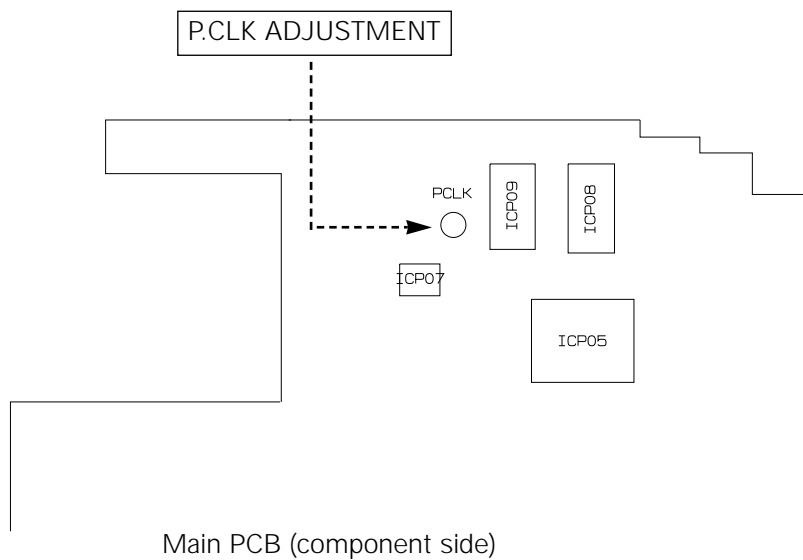

## 3. Zoom VR Center

- 1) Camera "E-E", 3100°K gray-scale chart.
- 2) Video(output) jack and EVR.
- 3) Connect monitor TV to video(output) jack.
- 4) Press the "BLC (MODE UP)/FADE (MODE DOWN)" button so that the OSD state is "D6 Z, CHK XX XX".
- 5) Press "START/STOP (CONFIRM)" button.
- 6) Then, the microprocessor will work ;
  - Find the Zoom VR Center position
  - Store the data to mode D6.

## 4. Auto hall

- 1) Camera "E-E", 3100°K gray-scale chart.
- 2) Video(output) jack and EVR.
- 3) Connect monitor TV to video(output) jack.
- 4) Press the "BLC (MODE UP)/FADE (MODE DOWN)" button so that the OSD state is "CD HALLA XX XX".
- 5) Press "START/STOP (CONFIRM)" button.
- 6) Then, the microprocessor will work ;
  - IRIS open, HALL maximum value found,
  - IRIS closed, HALL minimum value found,
  - IRIS open, HALL maximum value found,
  - Store the data to mode 02 and mode 01.
  - Store the HALL min./max. data to mode 7F and mode 80.

### 5. AUTO IRIS

- 1) Camera "E-E", 3100°K gray-scale chart.
- 2) Video(output) jack and AF MICOM.
- 3) Connect video(output) jack to waveform monitor input jack and monitor TV jack respectively.
- 4) Press the "BLC (MODE UP)/FADE (MODE DOWN)" button so that the OSD state is "CE IRISA XX XX".
- 5) Press "START/STOP(confirm)" Bttom.100IRE.
- 6) Then, the micro process of will work;
  - IRIS open, IRIS control minimum Value found.
  - IRIS close, IRIS control minimum Value found.
  - Store the data to mode 84 and mode 85.
- 7) The OSD shows "O.K".

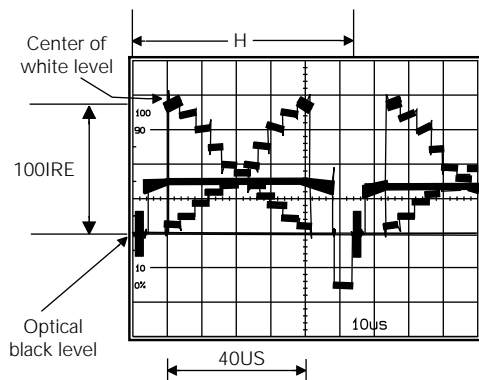

### 6. Auto white balance

- 1) Camera "E-E", 3100°K/5100°K gray-scale chart.
- 2) Video(output) jack and AF MICOM.
- 4) Connect vectorscope input jack to video(output) jack.
- 3) Press the "BLC (MODE UP)/FADE (MODE DOWN)" button so that the OSD state is "CF WBA XX XX".
  - a. W/B Indoor
    - a-1. Aim the camera at a 3100°K gray-scale chart illuminated at 1500 to 2000 lx. (40us)
    - a-2. Press "START/STOP (CONFIRM)" button so that the white vector moves to the center on screen of the vectorscope.
    - a-3. The OSD shows "OK!".
  - b. W/B Outdoor
    - b-1. Aim the camera at a 5100°K gray-scale chart illuminated at 1500 to 2000 lx. (40us)
    - b-2. Press "START/STOP (CONFIRM)" button so that the white vector moves to the center on screen of the vectorscope.
    - b-3. The OSD shows "OK!".

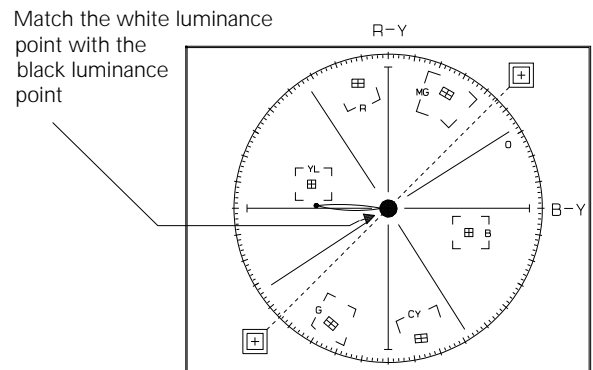

### 7. Pre white balance (I)

- 1) Camera "E-E", 3100°K gray-scale chart.
- 2) Video(output) jack and AF MICOM.
- 3) Connect vectorscope input jack to video(output) jack.
- 4) Press the "BLC (MODE UP)/FADE (MODE DOWN)" button so that the OSD state is "1C CWBR XX XX".
- 5) Aim the camera at a 3100°K gray-scale chart illuminated at 1500 to 2000 lx.
- 6) Adjust the " + (DATA UP)/ - (DATA DOWN)" button so that the white vector moves to the B-Y axial on screen of the vectorscope.
- 7) The OSD shows "OK!".

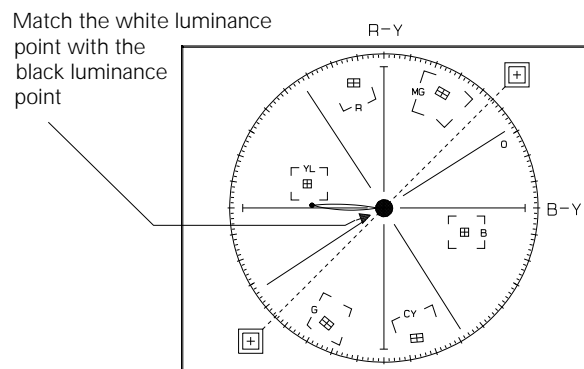

### 8. Pre white balance (II)

- 1) Camera "E-E", 3100°K gray-scale chart.
- 2) Video(output) jack and AF MICOM.
- 4) Connect vectorscope input jack to video(output) jack.
- 3) Press the "BLC (MODE UP)/FADE (MODE DOWN)" button so that the OSD state is "1D CWBB XX XX".
- 5) Aim the camera at a 3100°K gray-scale chart illuminated at 1500 to 2000 lx.
- 6) Adjust the "+ (DATA UP)/ - (DATA DOWN)" button so that the white vector moves to the R-Y axial on screen of the vectorscope.
- 7) The OSD shows "OK!".

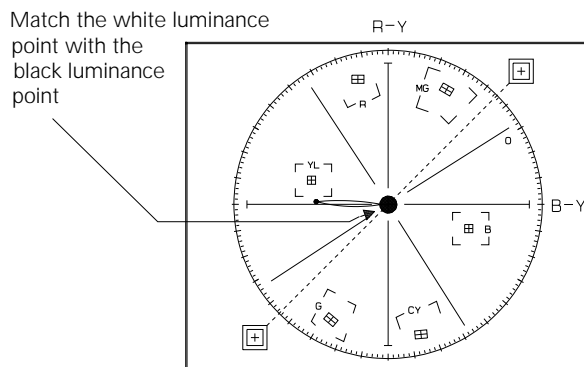

### 9. R-Y Positive Gain

- 1) Camera "E-E", 3100°K color bar chart.
- 2) Video(output) jack and register of EEPROM.
- 3) Connect video(output) jack to waveform monitor input jack and monitor TV jack respectively.
- 4) Press the "BLC (MODE UP)/FADE (MODE DOWN)" button so that the OSD state is "32 CRGP XX XX".
- 5) Aim the camera at a color bar chart illuminated at 1500 to 2000 lx.
- 6) Adjust the "+ (DATA UP)/ - (DATA DOWN)" button so that the red level is 70IRE.
- 7) Be sure to press the "START/STOP (CONFIRM)" button to memorize setting.
- 8) The OSD shows "OK!".

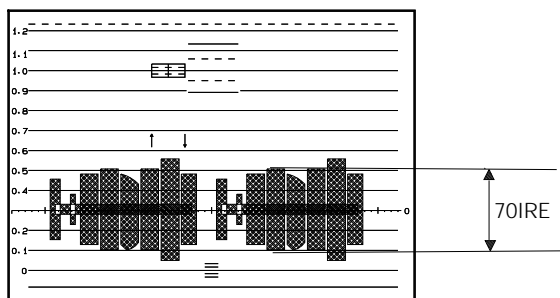

### 10. R-Y Negative Gain

- 1) Camera "E-E", 3100°K color bar chart.
- 2) Video(output) jack and register of EEPROM.
- 3) Connect video(output) jack to waveform monitor input jack and monitor TV jack respectively.
- 4) Press the "BLC (MODE UP)/FADE (MODE DOWN)" button so that the OSD state is "33 CRGN XX XX".
- 5) Aim the camera at a color bar chart illuminated at 1500 to 2000 lx.
- 6) Adjust the "+ (DATA UP)/ - (DATA DOWN)" button so that the cyan level is 65IRE.
- 7) Be sure to press the "START/STOP (CONFIRM)" button to memorize setting.
- 8) The OSD shows "OK!".

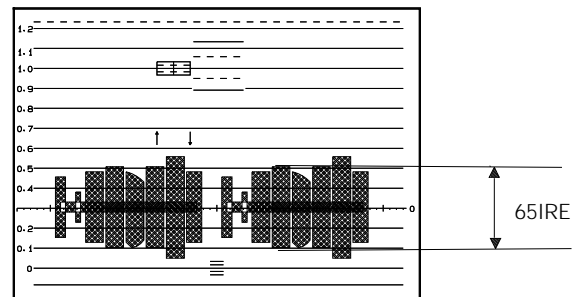

### 11. B-Y Positive Gain

- 1) Camera "E-E", 3100°K color bar chart.
- 2) Video(output) jack and register of EEPROM.
- 3) Connect video(output) jack to waveform monitor input jack and monitor TV jack respectively.
- 4) Press the "BLC (MODE UP)/FADE (MODE DOWN)" button so that the OSD state is "36 CBGP XX XX".
- 5) Aim the camera at a color bar chart illuminated at 1500 to 2000 lx.
- 6) Adjust the "+ (DATA UP)/ - (DATA DOWN)" button so that the blue level is 50IRE.
- 7) Be sure to press the "START/STOP (CONFIRM)" button to memorize setting.
- 8) The OSD shows "OK!".

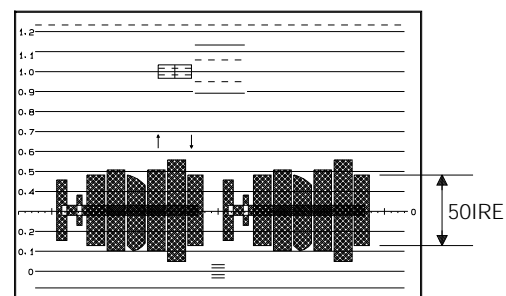

### 12. B-Y Negative Gain

- 1) Camera "E-E", 3100°K color bar chart.
- 2) Video(output) jack and register of EEPROM.
- 3) Connect video(output) jack to waveform monitor input jack and monitor TV jack respectively.
- 4) Press the "BLC (MODE UP)/FADE (MODE DOWN)" button so that the OSD state is "37 CBGN XX XX".
- 5) Aim the camera at a color bar chart illuminated at 1500 to 2000 lx.
- 6) Adjust the "+ (DATA UP)/ - (DATA DOWN)" button so that the yellow level is 50IRE.
- 7) Be sure to press the "START/STOP (CONFIRM)" button to memorize setting.
- 8) The OSD shows "OK!".

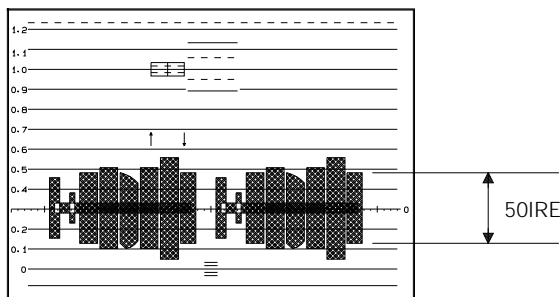

### 13. R-Y Positive Hue

- 1) Camera "E-E", 3100°K color bar chart.
- 2) Video(output) jack and register of EEPROM.
- 3) Connect video(output) jack to vectorscope input jack and monitor TV jack respectively.
- 4) Press the "BLC (MODE UP)/FADE (MODE DOWN)" button so that the OSD state is "39 CBHN XX XX".
- 5) Aim the camera at a color bar chart illuminated at 1500 to 2000 lx.
- 6) Adjust the "+ (DATA UP)/ - (DATA DOWN)" button so that the red vector is 104.
- 7) Be sure to press the "START/STOP (CONFIRM)" button to memorize setting.
- 8) The OSD shows "OK!".

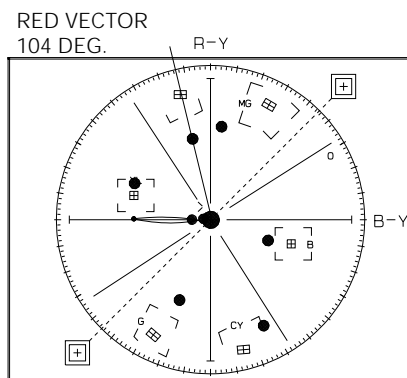

### 14. R-Y Negative Hue

- 1) Camera "E-E", 3100°K color bar chart.
- 2) Video(output) jack and register of EEPROM.
- 3) Connect video(output) jack to vectorscope input jack and monitor TV jack respectively.
- 4) Press the "BLC (MODE UP)/FADE (MODE DOWN)" button so that the OSD state is "38 CHGR XX XX".
- 5) Aim the camera at a color bar chart illuminated at 1500 to 2000 lx.
- 6) Adjust the "+ (DATA UP)/ - (DATA DOWN)" button so that the cyan vector is 284.
- 7) Be sure to press the "START/STOP (CONFIRM)" button to memorize setting.
- 8) The OSD shows "OK!".

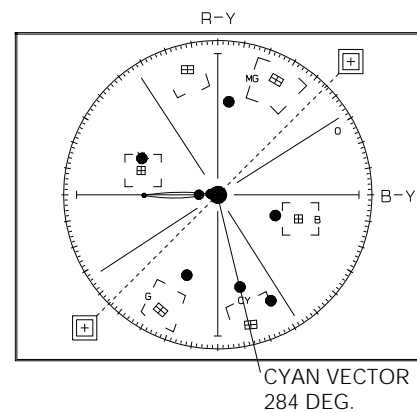

### 15. B-Y Negative Hue

- 1) Camera "E-E", 3100°K color bar chart.
- 2) Video(output) jack and register of EEPROM.
- 3) Connect video(output) jack to vectorscope input jack and monitor TV jack respectively.
- 4) Press the "BLC (MODE UP)/FADE (MODE DOWN)" button so that the OSD state is "34 CHYE XX XX".
- 5) Aim the camera at a color bar chart illuminated at 1500 to 2000 lx.
- 6) Adjust the "+ (DATA UP)/ - (DATA DOWN)" button so that the yellow vector is 165.
- 7) Be sure to press the "START/STOP (CONFIRM)" button to memorize setting.
- 8) The OSD shows "OK!".

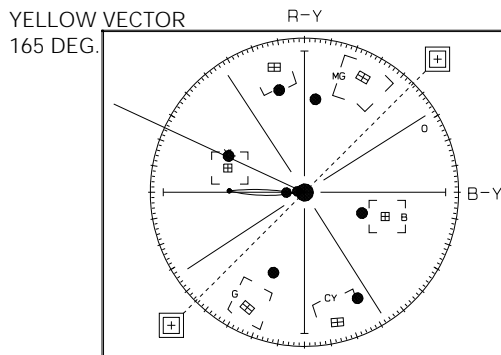

### 16. B-Y Positive Hue

- 1) Camera "E-E", 3100°K color bar chart.
- 2) Video(output) jack and register of EEPROM.
- 3) Connect video(output) jack to vectorscope input jack and monitor TV jack respectively.
- 4) Press the "BLC (MODE UP)/FADE (MODE DOWN)" button so that the OSD state is "35 CHB XX XX".
- 5) Aim the camera at a color bar chart illuminated at 1500 to 2000 lx.
- 6) Adjust the "+ (DATA UP)/ - (DATA DOWN)" button so that the blue vector is 346.
- 7) Be sure to press the "START/STOP (CONFIRM)" button to memorize setting.
- 8) The OSD shows "OK!".

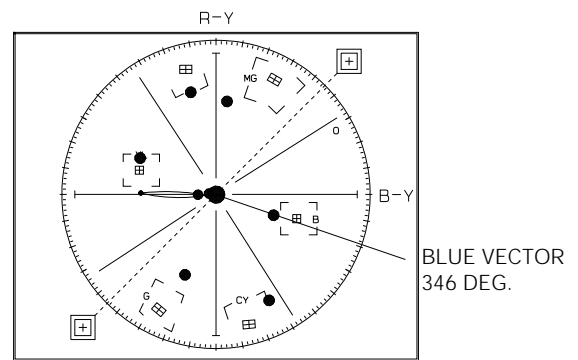

### 5-2-3 EVF Adjustment

**Note :** From this point forward, the structure of every adjustment is as follows.

Step	Adjustment Item
1.	Mode and input signal/ alignment tape
2.	Test point and ADJ. part
3.	Result and Remarks

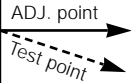

#### 1. AFC

- 1) VCR "PB", Alignment tape (Lion pattern).
- 2) TP1 and VRE01.
- 3) Connect digital voltmeter probe to TP1.
- 4) Adjust VRE01 so that the voltage is DC 2.5V ± 0.1V.

#### 2. V. Size

- 1) VCR "PB", Alignment tape (Lion pattern).
- 2) Viewfinder and VRE02.
- 3) Adjust VRE02 so that the counter circle on the lion pattern is perfect by round.

#### 3. Bright

- 1) VCR "PB", Alignment tape (Lion pattern).
- 2) Viewfinder and VRE03.
- 3) Adjust the VRE03 so that the 3rd and 4th steps of the lion pattern can be distinguished.

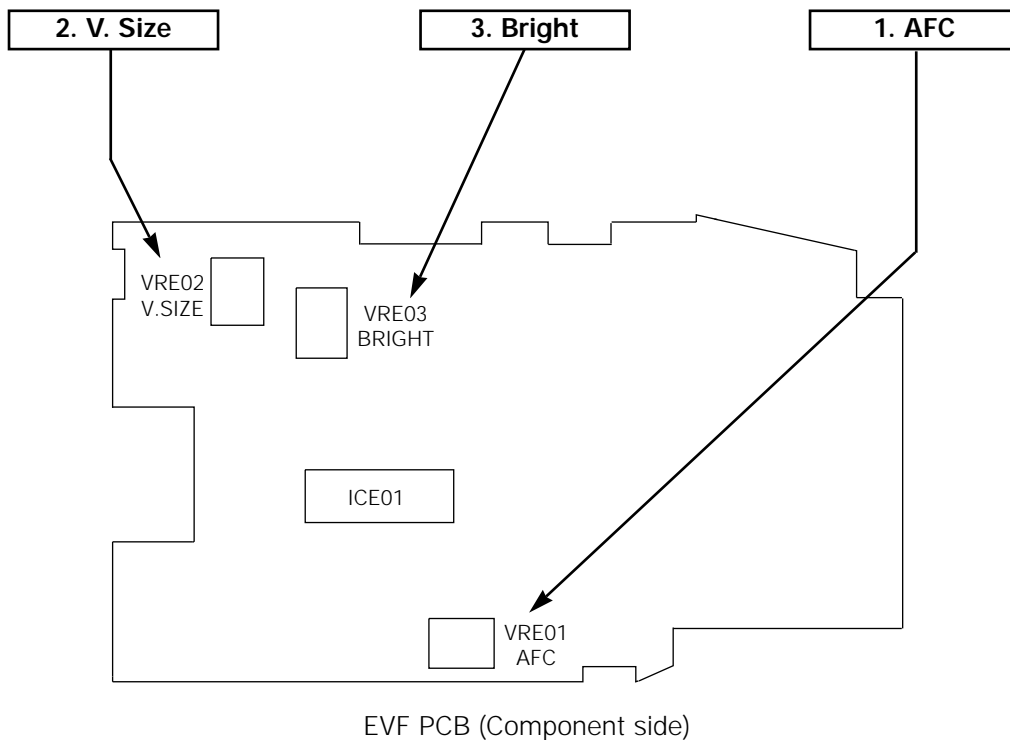

### 5-2-4 CVF Adjustment

**Note :**

1. The function buttons on the Rear Board are used to control the CVF adjustment.
2. After each adjustment step is completed, OSD shows "CONFIRM!".
3. EEPROM(ICE02) stores confirmed adjustment value of each adjustment step.
4. After finishing the adjustment, reset the main power source (OFF-ON) to memorize the adjustment data in EEPROM.

#### 5-2-4 (a) PREPARATION

1. How to get into the CVF adjust mode.

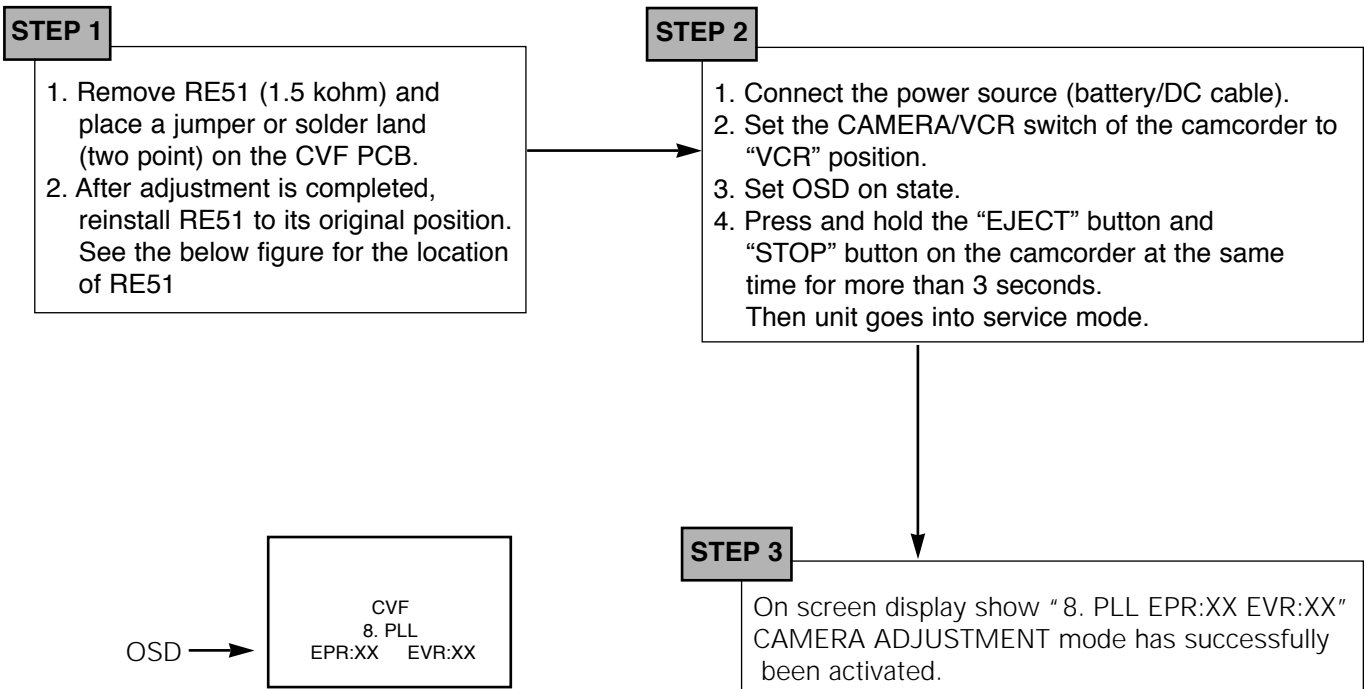

**Note :** When "XX XX" is shown in service adjustment procedures, this indicates variable values.

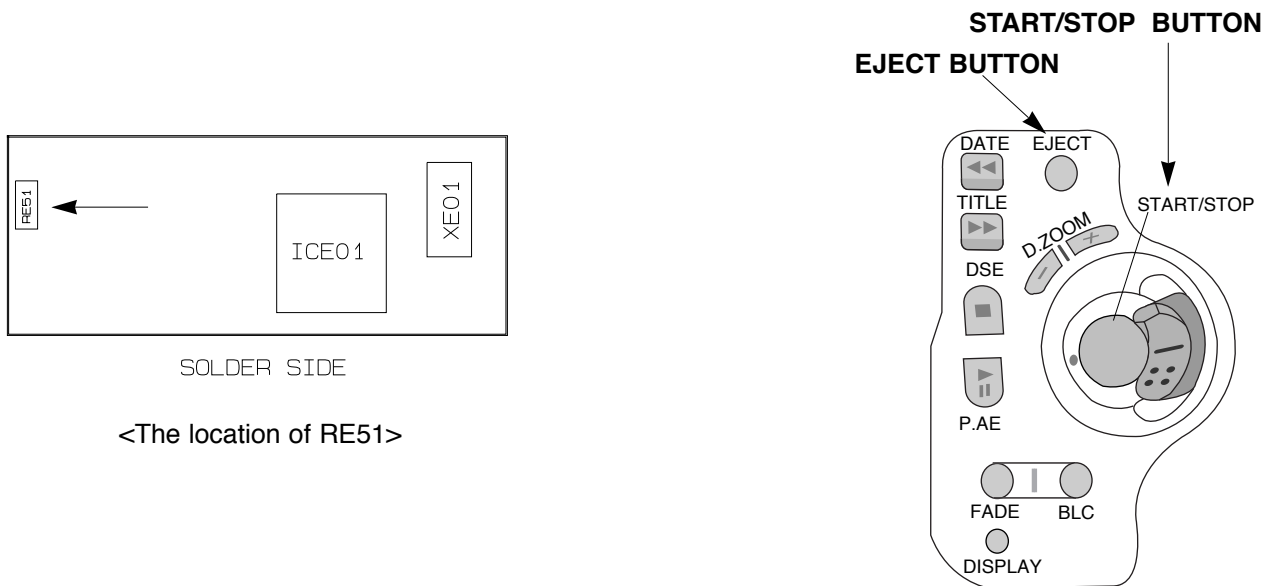

2. The following is a chart explaining the use of each button. In service adjustment mode, button names are different from those in customer camera function control mode. EX) DISPLAY button is the same as confirm.

Using Button	Adjustment
DISPLAY (CONFIRM)	Data store after finishing adjustment by DATA UP/DOWN button.
D. ZOOM - (DATA DOWN)	When changing data value of adjust state.
D. ZOOM + (DATA UP)	
BLC (MODE UP / DOWN)	Mode change.

Rear Board for camcorder adjustment

Figure of button placement when Rear Board is used for service adjustment.

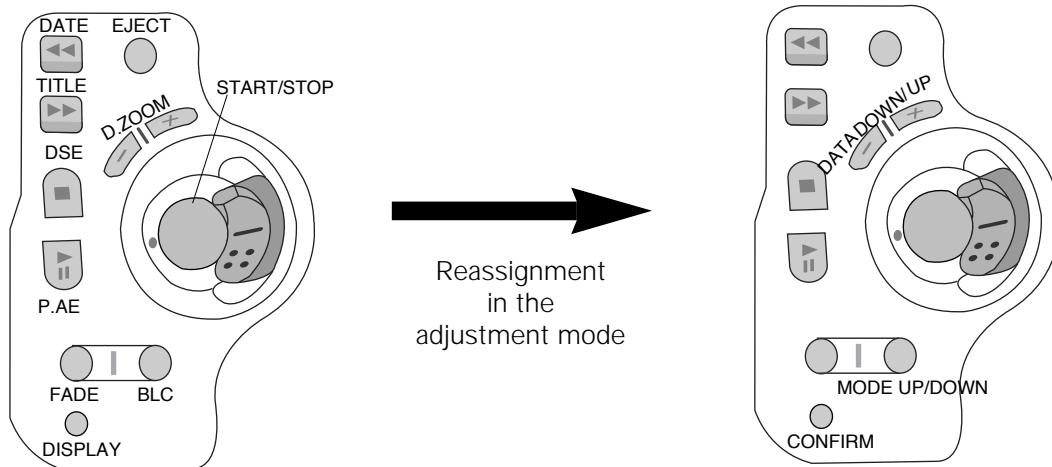

ADDRESS	MODE	EPR	EVR	MEAN	REMARK
0	TINT	XX	XX	TINT	ADJUST
1	COLOR	XX	XX	COLOR GAIN	ADJUST
2	BRIGHT	XX	XX	BRIGHT	ADJUST
3	CONTRAST	60	60	CONTRAST	FIXED
4	R SUB	XX	XX	R-BRIGHT	ADJUST
5	B SUB	XX	XX	B-BRIGHT	ADJUST
6	GAMMA 1	75	75	GAMMA1 GAIN	FIXED
7	GAMMA 2	B1	B1	GAMMA2 GAIN	FIXED
8	PLL	XX	XX	PLL	ADJUST
9	MODE1	02	02	HD-TIME DELAY	FIXED
A	MODE2	00	00	SYSTEM SELECTION	FIXED
B	MODE3	15	15	H-POSITION	FIXED

**Note :** "XX XX" indicates variable values.

5-2-4 (b) ADJUSTMENT

**Note :** 1. From this point forward, the structure of every adjustment is as follows.  
 2. See page 5-24 for the location of test points and adjustments.

Step	Adjustment Item
1.	Mode and input signal/ alignment tape
2.	Test point and ADJ. part
3.	Result and Remarks



1. PLL

- 1) VCR "PB", Color bar (SP).
- 2) RPD and EVR.
- 3) Connect oscilloscope probe to RPD.
- 4) Press the "BLC (MODE UP/DOWN)" button so that the OSD state is "08 PLL EPR:XX EVR:XX".
- 5) Adjust the "D.ZOOM+/- (DATA UP/DOWN)" button so that RPD level is  $DC1.8 \pm 0.1V_{p-p}$ .
- 6) Be sure to press the "DISPLAY(CONFIRM)" button to memorize setting.
- 7) The OSD shows "CONFIRM !".

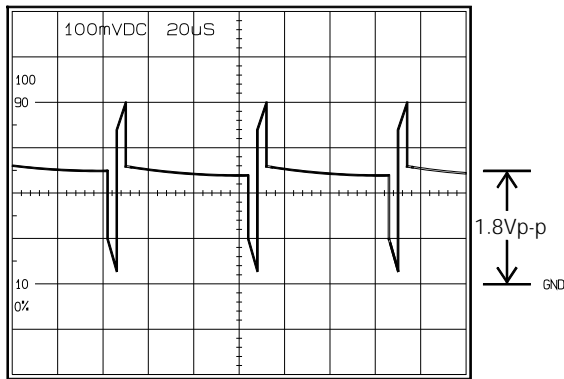

2. Brightness

- 1) VCR "PB", Color bar (SP).
- 2) G-OUT and EVR.
- 3) Connect an oscilloscope probe to G-OUT.
- 4) Press the "BLC (MODE UP/DOWN)" button so that the OSD state is "02 BRIGHT EPR:XX EVR:XX".
- 5) Adjust the "D.ZOOM+/- (DATA UP/DOWN)" button so that bright(Green) level is  $8.0V_{p-p}$ .
- 6) Be sure to press the "DISPLAY(CONFIRM)" button to memorize setting.
- 7) The OSD shows "CONFIRM !".

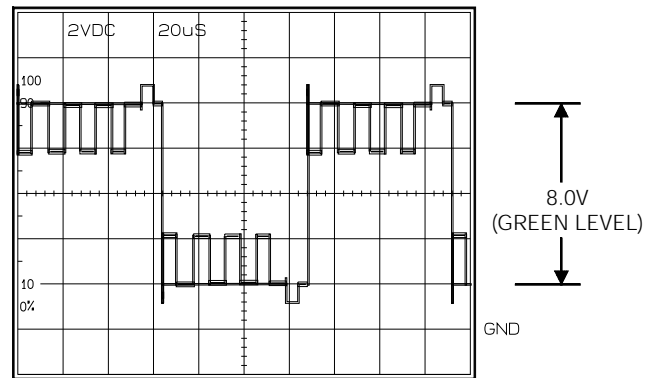

3. R-Sub Brighness

- 1) VCR "PB", Color bar (SP).
- 2) R-OUT and EVR.
- 3) Connect an oscilloscope probe to R-OUT.
- 4) Press the "BLC (MODE UP/DOWN)" button so that the OSD state is "04 R SUB EPR:XX EVR:XX".
- 5) Adjust the "D.ZOOM+/- (DATA UP/DOWN)" button so that R-OUT(Red) level is  $8.0V_{p-p}$ .
- 6) Be sure to press the "DISPLAY(CONFIRM)" button to memorize setting.
- 7) The OSD shows "CONFIRM !".

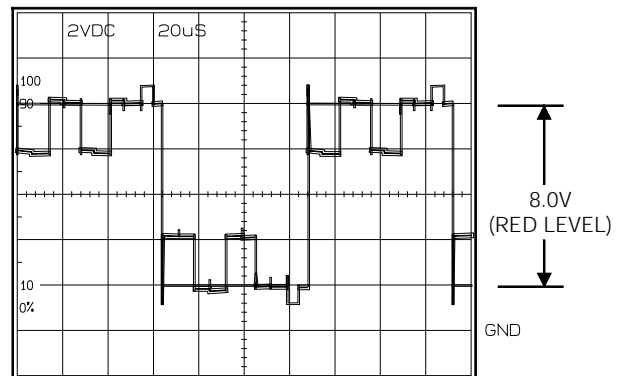

#### 4. B-Sub Brightness

- 1) VCR "PB", Color bar (SP).
- 2) B-OUT and EVR.
- 3) Connect an oscilloscope probe to B-OUT.
- 4) Press the "BLC (MODE UP/DOWN)" button so that the OSD state is "05 B BUB EPR:XX EVR:XX".
- 5) Adjust the "D.ZOOM+/- (DATA UP/DOWN)" button so that B OUT(Blue) level is 8.0Vp-p.
- 6) Be sure to press the "DISPLAY(CONFIRM)" button to memorize setting.
- 7) The OSD shows "CONFIRM!".

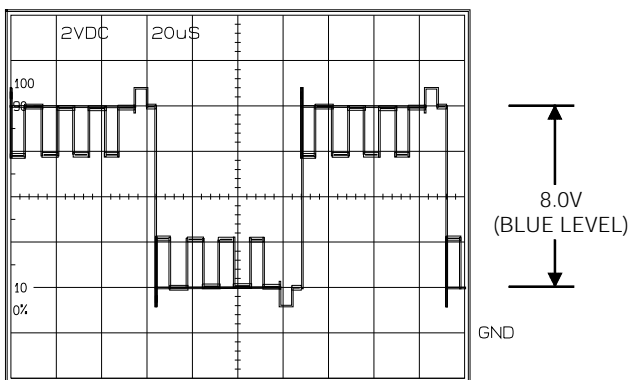

#### 5. Color

- 1) VCR "PB", Color bar (SP).
- 2) B-OUT and EVR.
- 3) Connect an oscilloscope probe to B-OUT.
- 4) Press the "BLC (MODE UP/DOWN)" button so that the OSD state is "01 COLOR EPR:XX EVR:XX".
- 5) Adjust the "D.ZOOM+/- (DATA UP/DOWN)" button so that the Yellow level is equal to the pedestal line.
- 6) Be sure to press the "DISPLAY(CONFIRM)" button to memorize setting.
- 7) The OSD shows "CONFIRM!".

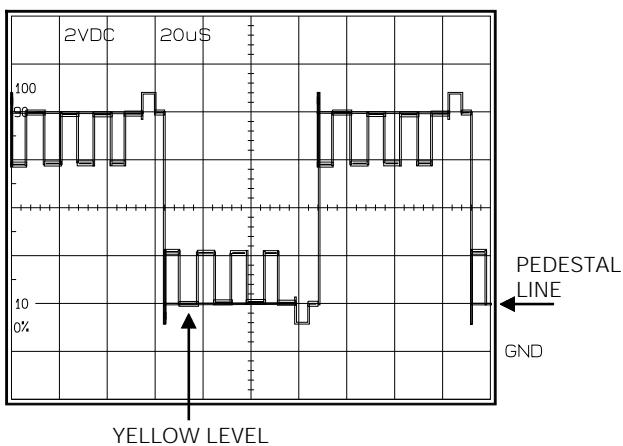

#### 6. HUE

- 1) VCR "PB", Color bar (SP).
- 2) B-OUT and EVR.
- 3) Connect an oscilloscope probe to B-OUT.
- 4) Press the "BLC (MODE UP/DOWN)" button so that the OSD state is "00 TINT EPR:XX EVR:XX".
- 5) Adjust the "D.ZOOM+/- (DATA UP/DOWN)" button so that the dual waveforms are superimposed.
- 6) Be sure to press the "DISPLAY(CONFIRM)" button to memorize setting.
- 7) The OSD shows "CONFIRM!".

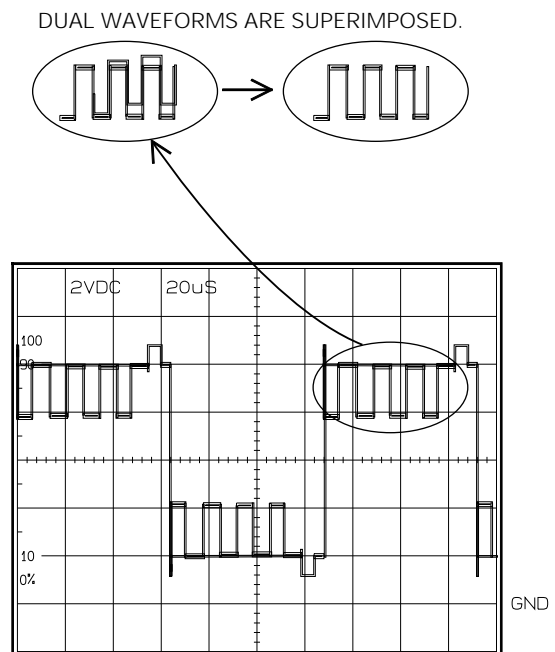

Alignment and adjustment

◆ Test point and adjustment points :

NO	ADDRESS	Adjustment name	Test point	Adjustment point	Spec.
1	08	PLL	PLL	EVR	1.8 ± 0.1V DC
2	02	BRIGHTNESS	G-OUT	EVR	8.0Vp-p
3	04	R-SUB BRIGHTNESS	R-OUT	EVR	8.0Vp-p
4	05	B-SUB BRIGHTNESS	B-OUT	EVR	8.0Vp-p
5	01	COLOR	B-OUT	EVR	-
6	00	HUE	B-OUT	EVR	-

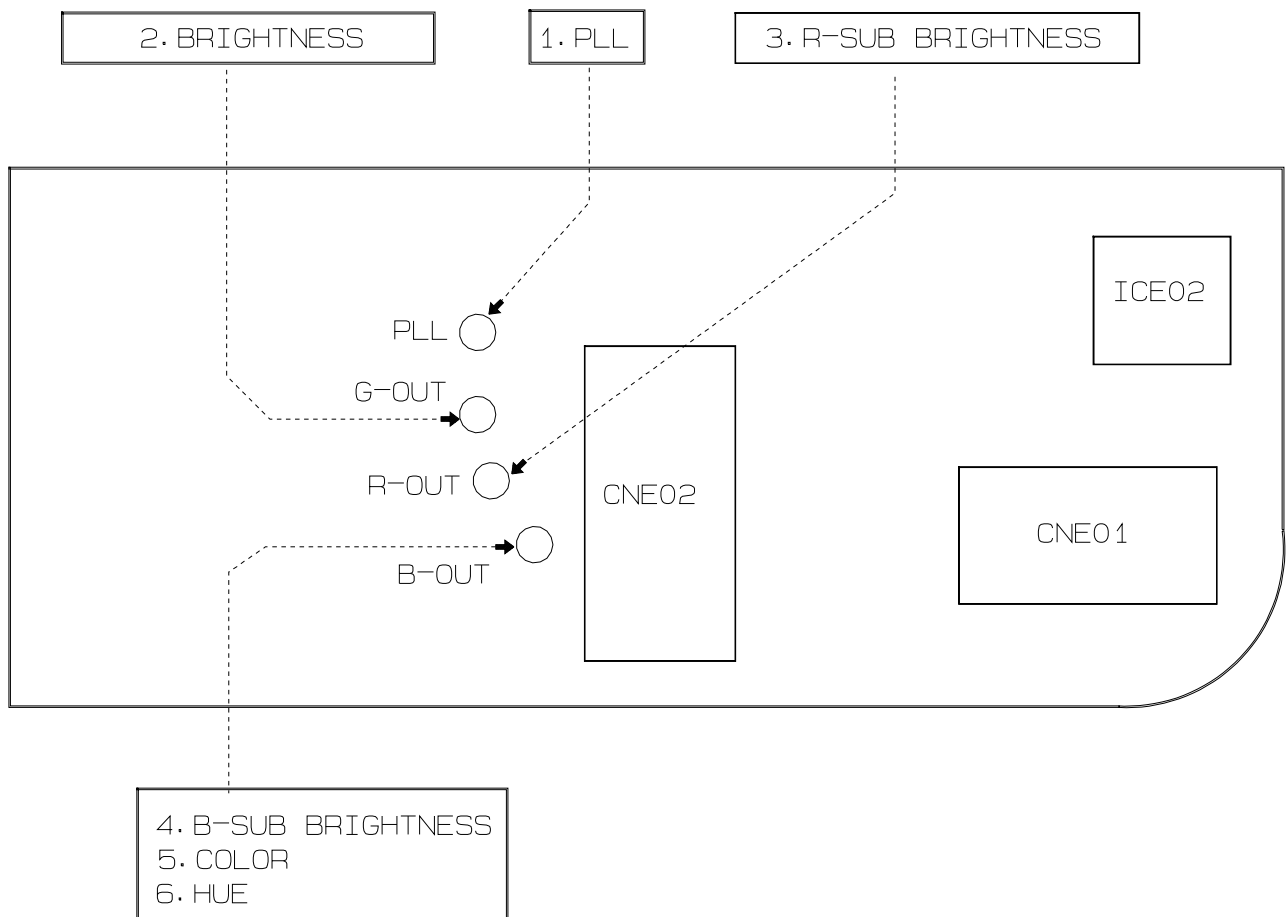
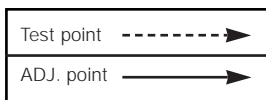

CVF PCB (Component side)

## 5-3 VCR Section Adjustment

### 5-3-1 Preparations

#### 1. Equipment :

- 1) Monitor TV.
- 2) Dual trace oscilloscope of over 20MHz band, incorporates delay mode.  
(Use 10 : 1 probe unless otherwise specified.)
- 3) Frequency counter
- 4) Pattern generator with video output terminal.
- 5) Digital voltmeter.
- 6) DC power supply.
- 7) Alignment tape (Color bar : SP)

#### 2. Composition of VCR PCBboards

- 1) Main PCB (system control/servo, video, audio,DC/DC converter, camera)
- 2) Rear PCB
- 3) Battery-Terminal PCB
- 4) Front PCB

#### 3. Set-up during adjustment

Since the video output signal obtained from the pattern generator is used as the adjusting signal for the VCR block, it is necessary that this video output signal be within the required specifications. Connect an oscilloscope to video input jack and make sure that the amplitude of the video SYNC signal is approximately 0.3V, that the video block amplitude is approximately 0.7V, that the burst signal amplitude is approximately 0.3V with fiat characteristics, and the signal level ratio between the burst signal and "Red" signal is 0.30 : 0.66. The video signal ( color bars ) used for VCR block electrical adjustment are shown in figure 1.

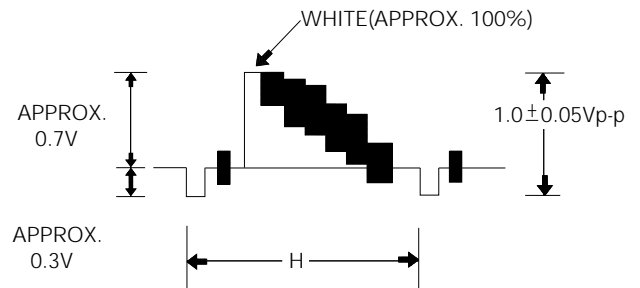

Fig. 1 Color bar signal pattern generator

#### 4. How to get into srvice "ADJUST" mode

##### STEP 1

1. Connect the power source (battery/DC cable).
2. Set the knob-power of the camcorder to VCR position.
3. Press the "EJECT" button to eject mode.

##### STEP 2

1. Press and hold "EJECT" button and "DATE" button on the REAR board at the same time for more than 5 seconds.
2. If OSD Shows like the figure below, VCR adjustment mode has been successfully activated.
3. Insert tape into housing assy and then perform the adjustments.

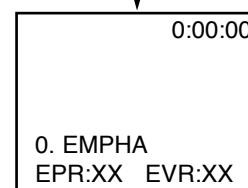

5. The location of function button.

Rear Board for camcorder adjustment

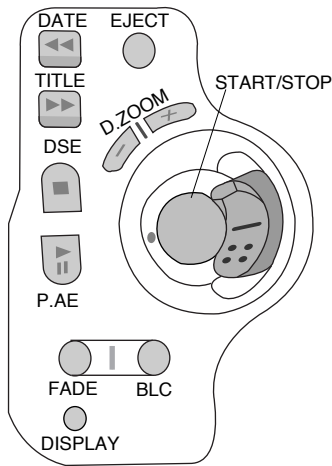
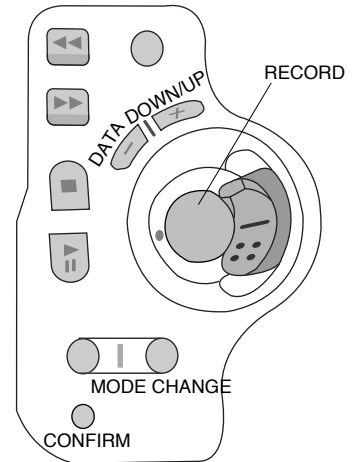

Figure of button placement when Rear Board is used for service adjustment.



Reassignment  
in the  
adjustment mode

**Note :** In service adjustment mode, button names are different from those in customer function control mode. EX) DISPLAY button is the same as CONFIRM.

5-3-2 Timing Chart of Program SWITCH

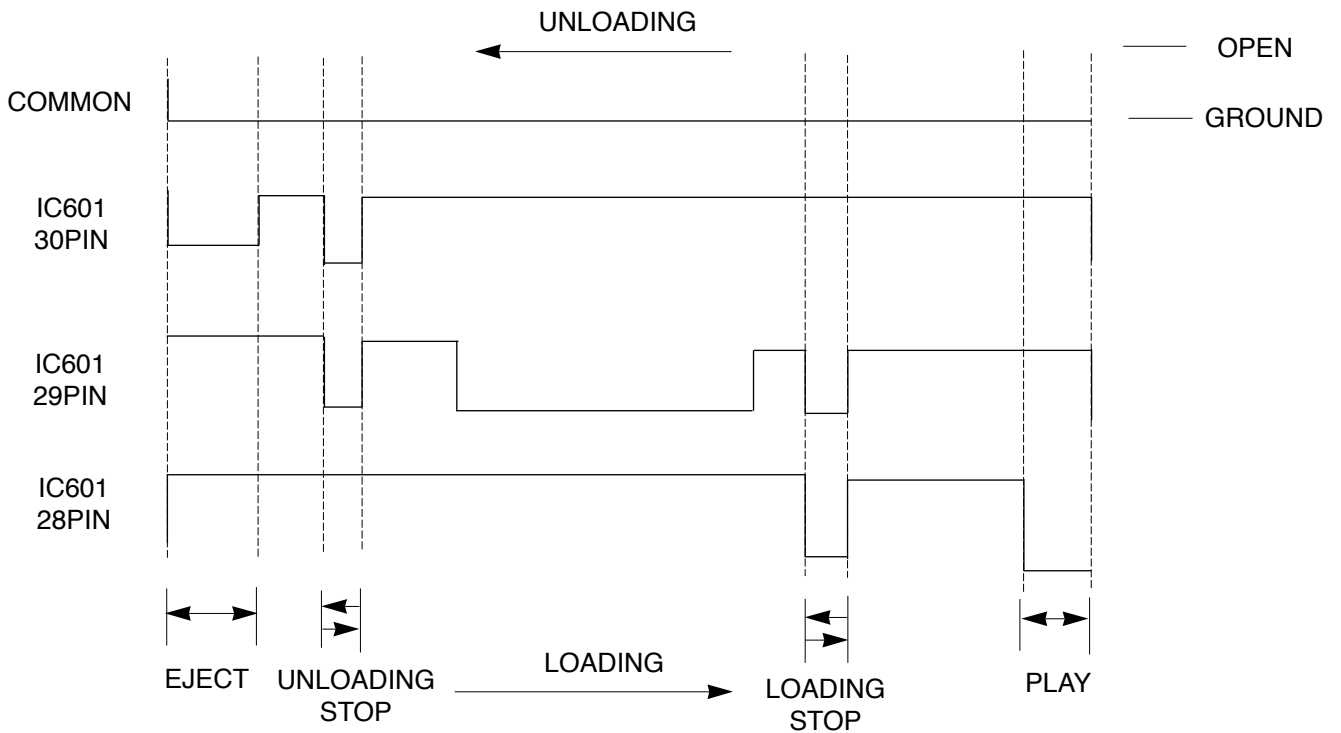

POSITION	IC601 30PIN	IC601 29PIN	IC601 28PIN	Action Mode
EJECT	L	H	H	EJECT
UNLOADING STOP	L	L	H	UNLOADING STOP
LOADING STOP	H	L	L	LOADING STOP
PB	H	H	L	PLAY,FF,REW,STILL...

### 5-3-3 VCR Section

**Note 1 :** From now on, the structure of every adjustment is as follows.

Step	Adjustment Item
1.	Mode and input signal/ alignment tape
2.	Test point and ADJ. part
3.	Result and Remarks

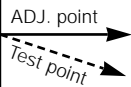

**Note 2 :** How to connect video in/out signal

- Connect the video cable to pattern generator and ass'y A/V Jack, so that video in/out signal is adjusted automatically as shown below (Fig.2).

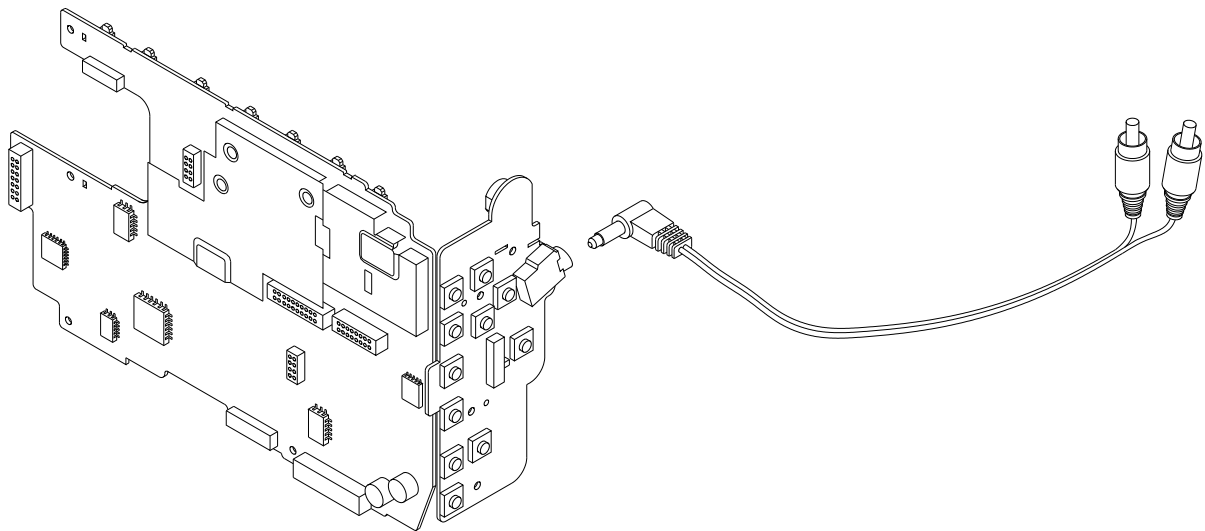

Fig. 2 Video Signal Connection

**Note 3 :** How to record - Press the "START/STOP" button (Red button) on the Rear board in the adjustment mode.

**Note 4 :** 1. Video block - See page 5-30 for the location of tests points and adjustments.  
 Audio block - See page 5-31 for the location of tests points and adjustments.  
 2. Press the "BLC" button of set for mode change.

**Note 5 :** The OSD information.  
 "XX" means arbitrary values. It can be different number depend on the condition.

0. EMPHA EPR:XX EVR:XX
---------------------------

## Alignment and adjustment

### 0. Y-EMPHASIS (Video block)

- 1) Rec, 100% color bar signal.
- 2) TP201 and EVR.
- 3) Confirm the "0. Y-EMPHASIS" mode by pressing the "BLC" (MODE CHANGE) button of unit.
- 4) Connect an oscilloscope to TP201.
- 5) Press the "- (DATA DOWN)/ + (DATA UP)" button so that the TP201 is  $0.5 \pm 0.02V_{p-p}$  from SYNC tip to peak level.
- 6) Be sure to press the "DISPLAY (CONFIRM)" button on unit to memorize setting.

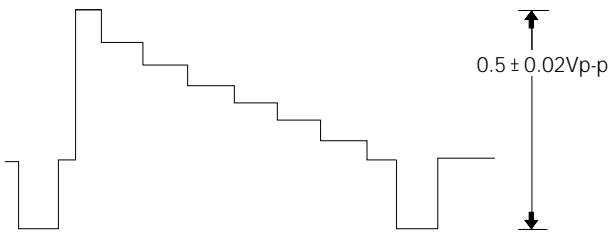

### 1. "Y-SEP" Adjustment is fixed to EVR data 74.

### 2. Y-FM Carrier Frequency (Video block)

- 1) Rec, no signal input
- 2) TP203 and EVR
- 3) Confirm the "5. CARR" mode by pressing the "BLC" (MODE CHANGE) button of unit.
- 4) Connect frequency counter probe to TP203.
- 5) Press the "- (DATA DOWN)/ + (DATA UP)" button so that the TP203 is  $4.38 \pm 0.02MHz$ .
- 6) Be sure to press the "DISPLAY (CONFIRM)" button on unit to memorize setting.

## 3. Y-FM Deviation (Video block)

**Note :** Confirm that “Y-FM Carrier Frequency” and “PB Output Level” adjustment have been completed.

- 1) Rec PB, 100% color bar signal.
- 2) TP203 and EVR.
- 3) Record the color bar signal at adjustment mode.
- 4) Turn power off/on and then playback the recorded signal.
- 5) Confirm the playback output of TP203.  
(Specified value:  $1.0 \pm 0.05V_{p-p}$ )
- 6) If the specified value is not satisfied, repeat above three steps.

- When larger than specified value :  
press the “+ (DATA UP)” and then  
press the “DISPLAY (CONFIRM)” button.

- When smaller than specified value :  
press the “- (DATA DOWN)” and then  
press the “DISPLAY (CONFIRM)” button.

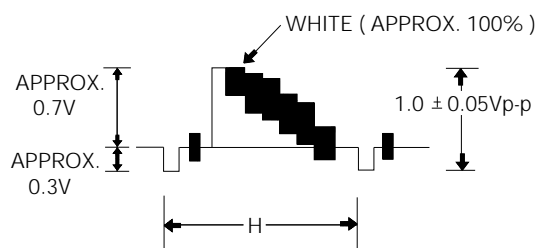

## 4. REC Y Level (Video block)

“4. REC Y” Adjustment is fixed to EVR data B9.

## 5. PB Output Level (Video block)

- 1) PB, color bar tape.
- 2) TP204 and EVR.
- 3) Confirm the “5. PB Y” mode by pressing the “BLC” (MODE CHANGE) button of unit.
- 4) Connect an oscilloscope to TP204.
- 5) Press the “- (DATA DOWN)/+ (DATA UP)” button so that the TP204 is  $1.0 \pm 0.05V_{p-p}$  from SYNC to peak level.
- 6) Be sure to press the “DISPLAY (CONFIRM)” button on unit to memorize setting.

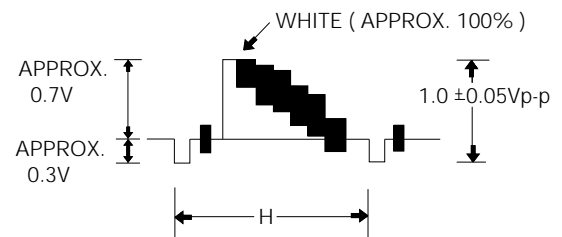

Alignment and adjustment

◆ Test point and adjustment points :

NO	ADDRESS	Adjustment name	Test point	Adjustmen
0	Y-EMPHASIS	TP201	EVR	$0.5 \pm 0.02V_{p-p}$
1	Y/C SEPARATION	TP202	EVR data fixed	74
2	Y-FM CARRIER FREQUENCY	TP203	EVR	$4.38 \pm 0.02MHz$
3	Y-FM DEVIATION	TP203	EVR	$1.0 \pm 0.05V_{p-p}$
4	REC Y LEVEL	-	EVR data fixed	B9
5	PB OUTPUT LEVEL	TP204	EVR	$1.0 \pm 0.05V_{p-p}$

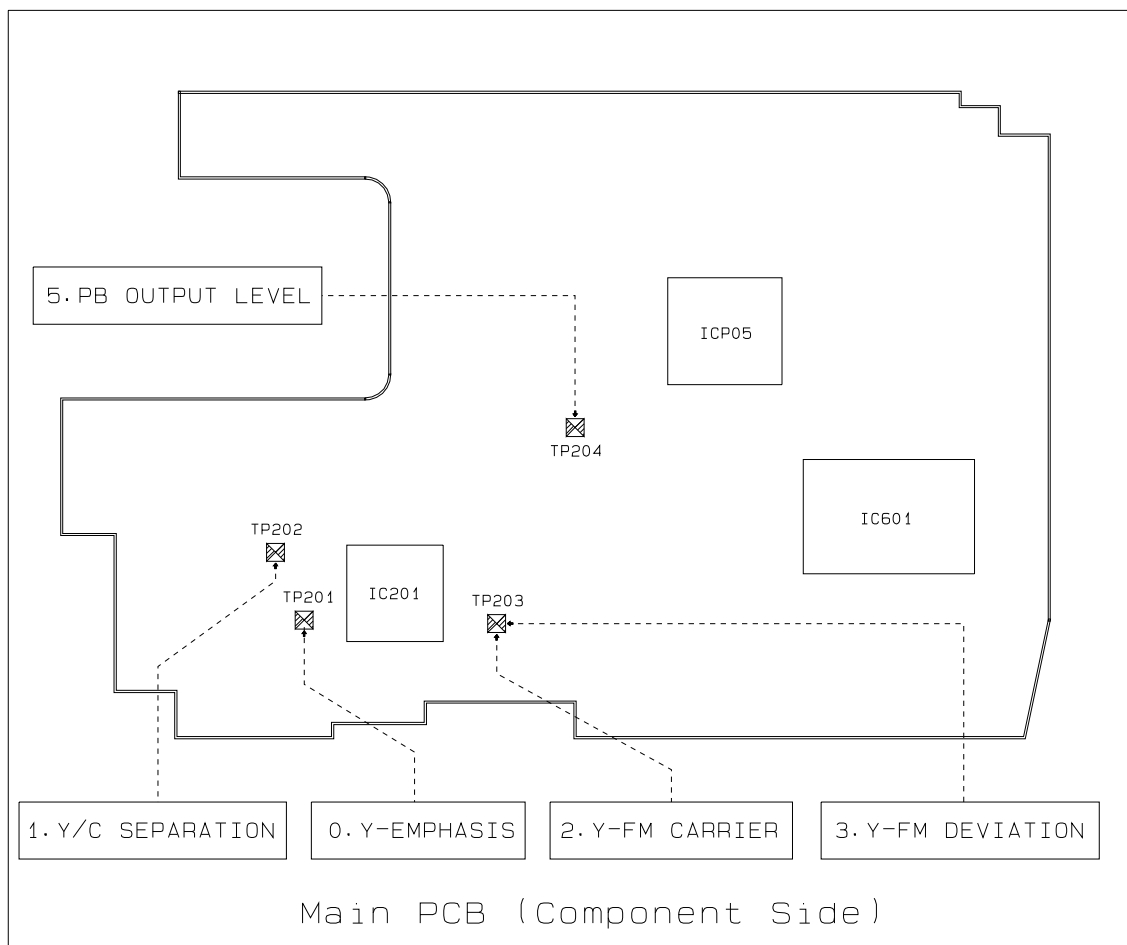
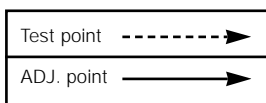

6. Audio BPF (Audio block)

- 1) PB, color bar tape.
- 2) Pin 10 of CTP501 and EVR.
- 3) Confirm the "A. AUDIO BPF" mode by pressing the "BLC" (mode change) button on UNIT.
- 4) Connect an oscilloscope to pin 10 of CTP501.
- 5) Press the "- (DATA DOWN) / +(DATA UP)" button so that the output waveform is completed sine wave and the distortion is miniized.
- 6) Be sure to Press the "DISPLAY(CONFIRM)" button on unit to memorize setting.

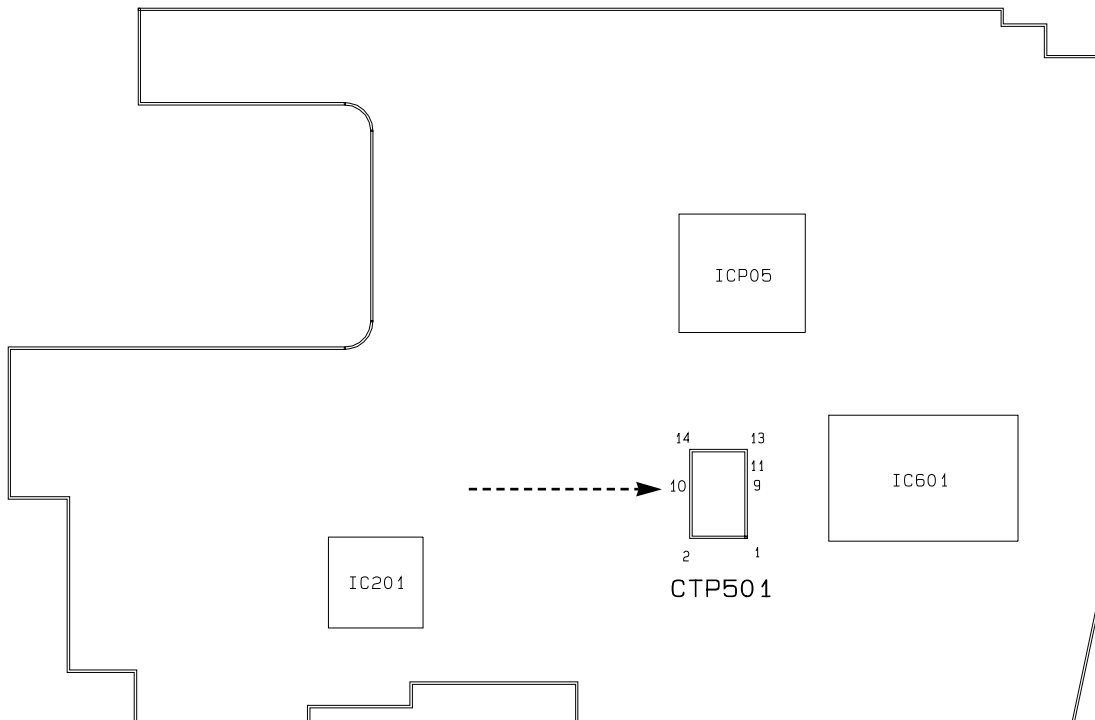
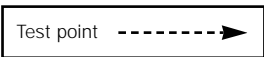
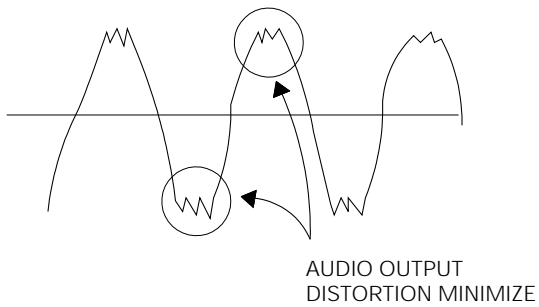

### 7. Head Switching

- 1) PB, color bar tape.
- 2) EVR.
- 3) Confirm the "7. HD SWP" mode by pressing the "BLC" (MODE CHANGE) button of unit.
- 4) The data of Head S/W is set to 6.2H ~ 6.7H automatically.
- 5) Be sure to press the "DISPLAY (CONFIRM)" button on unit to memorize setting.

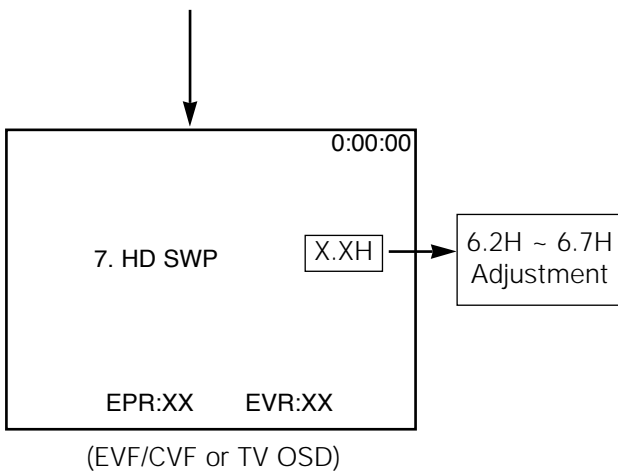

### 8. Model set

- 1) PB, color bar tape.
- 2) EVR.
- 3) Confirm the "8. MODEL" mode by pressing the "BLC" (MODE CHANGE) button of unit.
- 4) Press the "- (DATA DOWN)/+(DATA UP)" button so that OSD shows "EPR:XX EVR:XX". "XX" is different depend on the models as shown below.
- 5) Be sure to press the "DISPLAY (CONFIRM)" button on unit to memorize setting.

NTSC	PAL
- SCA20 : 20	- VP-A20 : 20
- SCA23 : 23	- VP-A22 : 22
- SCA25 : 25	- VP-A23 : 23
	- VP-A21 : 20

---

## 6. Exploded View and Parts List

---

	Page
6-1 Cabinet Assembly (1) - - - - -	6-2
6-2 Cabinet Assembly (2) - - - - -	6-4
6-3 Cabinet Assembly (3) - - - - -	6-6
6-4 Mechanical Parts (1) - - - - -	6-8
6-5 Mechanical Parts (2) - - - - -	6-10
6-6 Mechanical Parts (3) - - - - -	6-12
6-7 EVF (VP-A20/A22) - - - - -	6-14
6-8 CVF (VP-A21/A23) - - - - -	6-16

## 6-1 Cabinet Assembly (1)

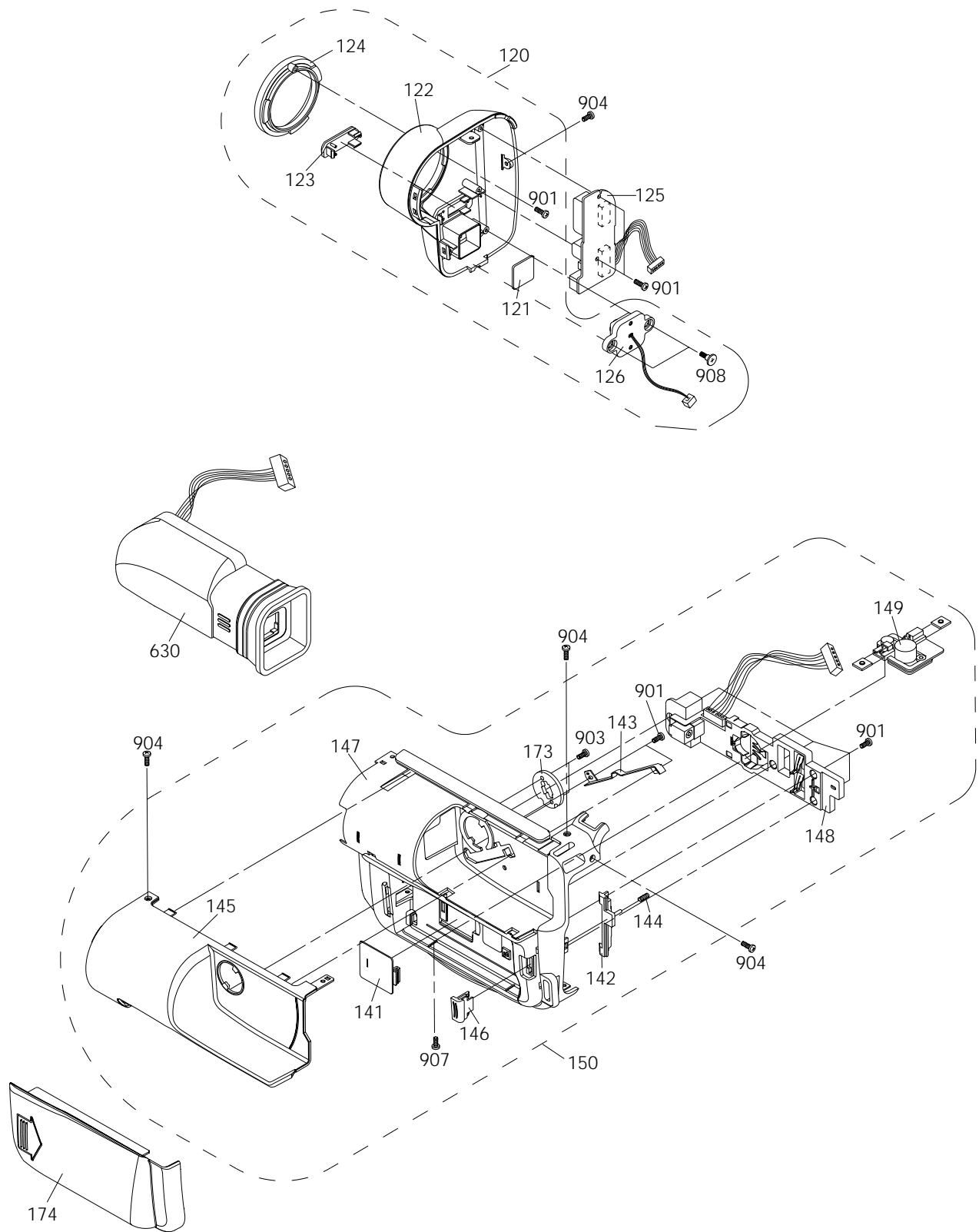

Loc. No	New Part No	Description and Specification	Remark
120	AD98-11242D	ASSY-CASE FRONT;VP-A20,-	VP-A20/A21
120	AD98-11250J	ASSY-CASE FRONT;VP-A22,-	VP-A22
120	AD98-11250H	ASSY-CASE FRONT;VP-A23,-	VP-A23
121	AD63-70068A	SHEET-MIC;-,-,HIMERON,-,-,-,-,-,VP-A20	
122	AD64-30930A	CASE-FRONT;-,-,ABS,94HB,-,-,-,-,-,VP-A20	VP-A20/A21
122	AD64-30930C	CASE-FRONT;-,-,ABS,94V0,-,-,-,-,-,SC-A20	VP-A22
122	AD64-30930B	CASE-FRONT;-,-,ABS,94HB,-,-,-,-,-,VP-A23	VP-A23
123	AD64-40676A	WINDOW-REMOCON;-,-,PC,-,-,-,-,-,BLK,-,-,VP-A20	
124	AD67-10191A	LENS-HOOD;-,-,-,PC(BLK),-,-,-,-,-,VP-A20	
125	AD90-10830Z	ASSY-FRONT BOARD;VP-A20,FRONT(MOD)	VP-A20/A21/A23
125	AD90-10831A	ASSY-FRONT BOARD;VP-A22,FRONT(MOD-GYRO)	VP-A22
126	AD98-12024P	ASSY-MIC;VP-A20,-	
141	AC63-30040A	COVER-LI BATTERY;PP,HB,T1.5,BLK,H3.5,-,-,V	
142	AD61-30214A	LOCKER-BATT EJECT;-,-,POM,-,-,BLK,-,-,VP-A20	
143	AD61-60532A	SPRING-EVF;-,-,-,BE-CU,-,-,-,-,-,VP-A57	
144	AD61-60540A	SPRING-HOLDER;-,-,-,SUS 304,-,-,-,-,-,CS97	
145	AD63-30568A	COVER-LEFT;-,-,ABS94,HB,-,-,-,-,-,VP-A20	
146	AD64-10847A	KNOB-BATT EJECT;-,-,ABS94,HB,-,-,-,-,-,VP-A20	
147	AD64-30932A	CASE-LEFT;-,-,ABS94,HB,-,-,-,-,-,VP-A20	
148	AD90-10822G	ASSY-TERMINAL;A2-P/J,SAMSUNG	
149	AD98-12025D	ASSY-BASE TRIPOD;VP-A20,BLK	
150	AD98-11242C	ASSY-CASE LEFT;VP-A20,-	
173	AD61-20976A	HOLDER-EVF;-,-,POM,-,-,BLK,-,-,VP-A57	
174	AD63-30567A	COVER-BATTERY;-,-,ABS94,HB,-,-,-,-,-,-	
630	AD90-10824G	ASSY-EVF;A2-PJ,PAL	VP-A20
630	AD90-10831F	ASSY-EVF;VP-A22/XEU,EIS,32X,EVF	VP-A22
630	AD90-10831G	ASSY-CVF;VP-A23/XEU,64X,CVF	VP-A23
630	AD90-10839V	ASSY-CVF;VP-A21	VP-A21
901	AC60-10055A	SCREW-TAPPING;BH,+,-,M2,X4,FZB	
903	AC60-10054A	SCREW-TAPPING;BH,+,-,M2,X6,FZB	
904	AC60-10020A	SCREW-MACHINE;BH,+,-,M2,X5,FZB,FE,UP,-,-	
907	AC60-10019A	SCREW-MACHINE;BH,+,-,M2,X4,FZB,FE,UP,-,-	
908	AC60-12119A	SCREW-TAP TITE;-,-,BH,+,-,-,SWRCH18A2P4	

## 6-2 Cabinet Assembly (2)

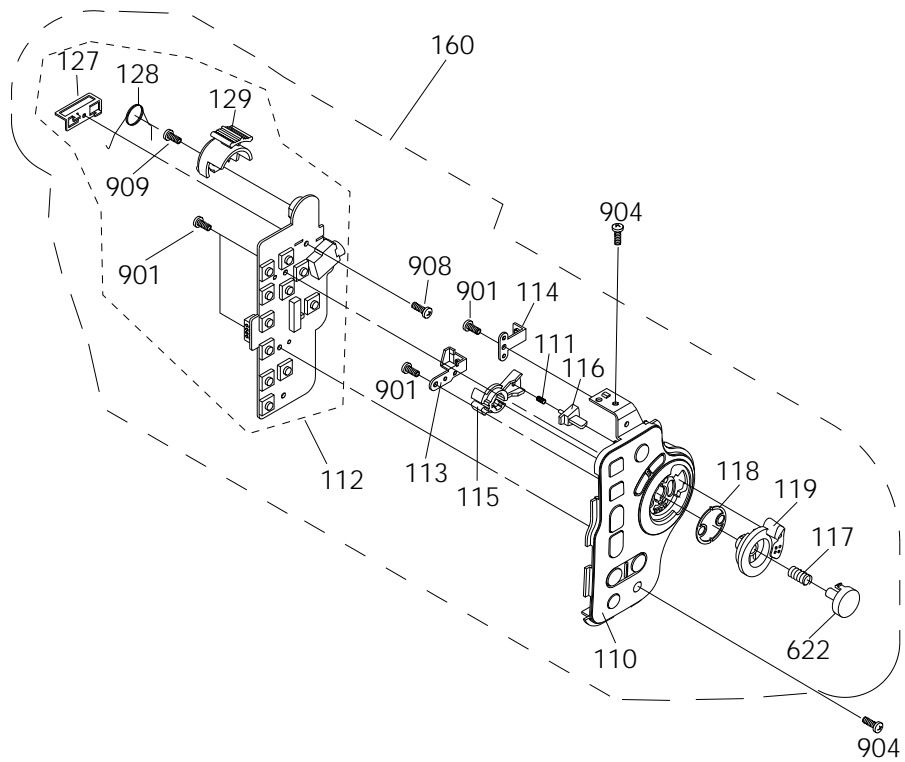
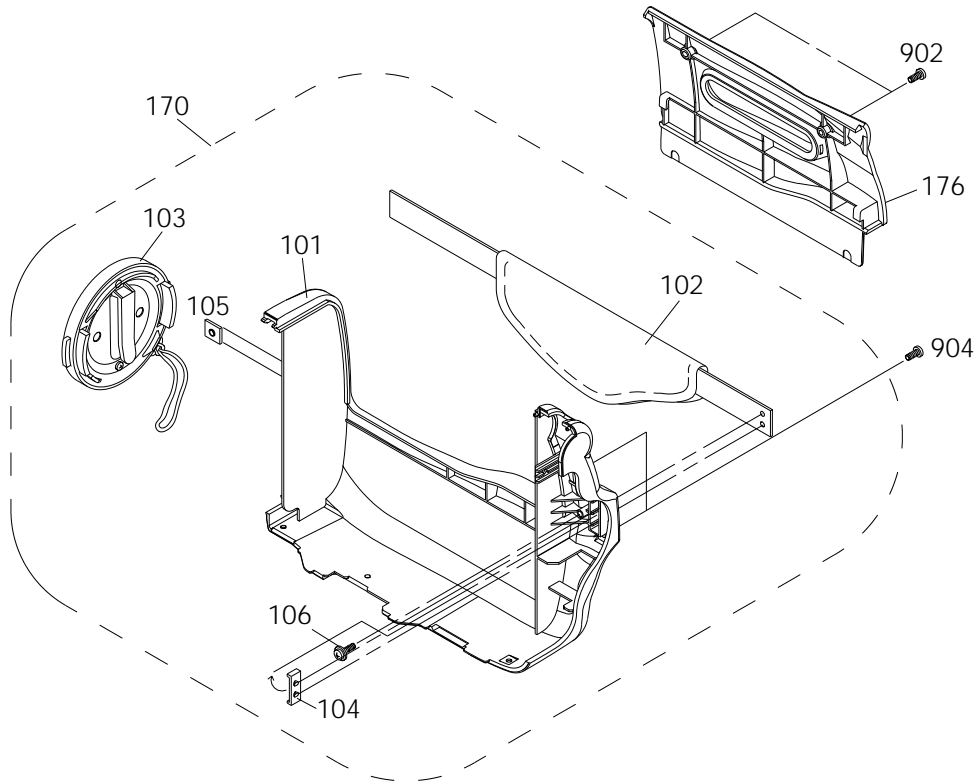

Loc. No	New Part No	Description and Specification	Remark
101	AD64-30935A	CASE-RIGHT;-ABS94,HB,-,-,-,VP-A20	
102	AC63-10007A	GRIP-BELT ASSY;LEATHER,BLK,T1.5,-,SV-H66	
103	AD61-22018A	CAP-HOOD;-ABS94,HB,-,-,VP-A20	
104	AD61-20977A	HOLDER-GRIP;-PBT,-,BLK,-,VP-A57	
105	AC61-20223A	HOLDER-LOCK;SECC,T1.0,NAT,-,-,-	
106	AD60-10509A	SCREW-TAP TITE;-PWH,+,-,M2X5,5,-	
110	AD64-30936A	CASE-REAR;-ABS94,HB,-,-,-,VP-A20	VP-A20/A21
110	AD64-30936D	CASE-REAR;-ABS94,HB,-,-,-,SC-A25	VP-A22
110	AD64-30936C	CASE-REAR;-ABS94,HB,-,-,-,SC-A23	VP-A23
111	66674-641-610	SPRING-KNOB POWER;SUS304 WPB	
112	AD59-10538A	UNIT-REAR;VP-A20,-	
113	AD61-11038A	BRACKET-REAR/RIGHT A;-SECC,-,T0.6,-,-,V	
114	AD61-11039A	BRACKET-REAR/RIGHT B;-SECC,-,T0.6,-,-,V	
115	AD61-21087A	HOLDER-POWER;-POM,-,NTR,-,VP-A20	
116	AD61-40419A	STOPPER-POWER;-ABS94,HB,-,-,VP-A20	
117	AD61-60521A	SPRING-REC;-TS,SWPB,0.25,4.3,-,SC-80	
118	AD61-60523A	SPRING-S/S;-,-,SUS304,0.2,-,-,SV-D100	
119	AD64-10843A	KNOB-POWER;-ABS94,HB,-,-,VP-A20	
127	AD61-22014A	HOLDER-ZOOM;-ABS94HB,T0.8,-,-,-	
128	AD61-60568A	SPRING-ZOOM;-,-,SUS304,-,D0.55,-,SV-S99	
129	AD64-10844A	KNOB-T/W;-ABS94,HB,-,-,VP-A20	
160	AD98-12024N	ASSY-CASE REAR;VP-A20,-	VP-A20/A21
160	AD98-12024X	ASSY-CASE REAR;SC-A25,-	VP-A22
160	AD98-12024W	ASSY-CASE REAR;SC-A23,-	VP-A23
170	AD98-11242N	ASSY-CASE RIGHT;VP-A20,-	
176	AD98-11242G	ASSY-COVER HOUSING;VP-A20,-	
622	AD64-11005A	BUTTON-REC;-ABS94,HB,-,-,VP-A20/SEUK	
901	AC60-10055A	SCREW-TAPPING;BH,+,-,M2,X4,FZB	
902	AD60-10001A	SCREW-MACHINE;BH,B,1.7*5.5,-,FE,BLACK,-,	
904	AC60-10020A	SCREW-MACHINE;BH,+,-,M2,X5,FZB,FE,UP,-,-	
908	AC60-12119A	SCREW-TAP TITE;-BH,+,-,-,SWRCH18A2P4	
909	AD60-10510A	SCREW-MACHINE;-PLAN,+,-,M1.4X5,5,BLK,FE	

### 6-3 Cabinet Assembly (3)

---

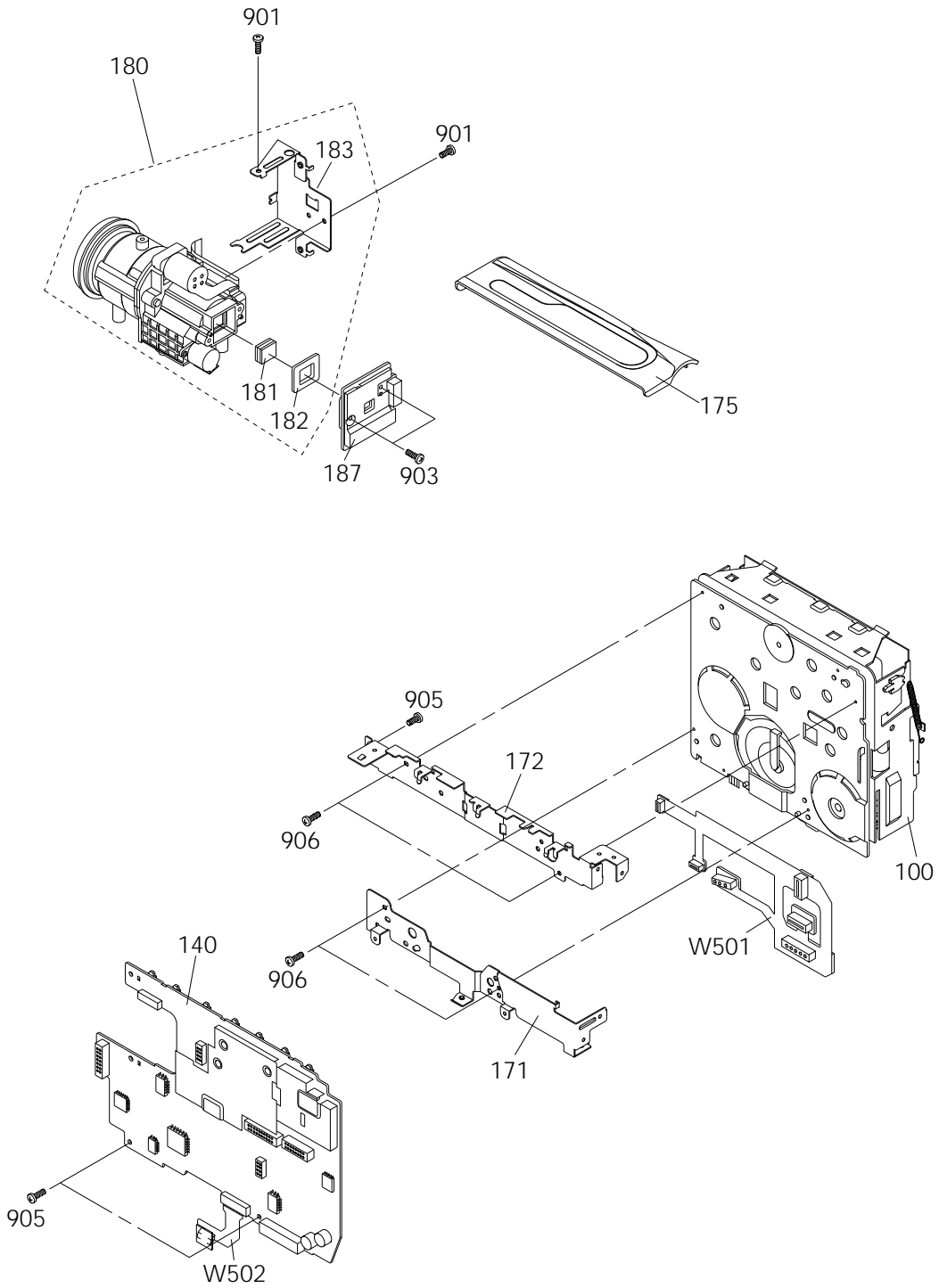

Loc. No	New Part No	Description and Specification	Remark
100	AD96-10473L	ASSY-8MM DECK;DE-6BPN,-	
140	AD90-10823B	ASSY-MAIN BOARD;VP-A20,PAL	VP-A20
140	AD90-10833A	ASSY-MAIN BOARD;VP-A22,PAL	VP-A22
140	AD90-10832Z	ASSY-MAIN BOARD;VP-A23,PAL	VP-A23
140	AD90-10839U	ASSY-MAIN BOARD;VP-A21,PAL	VP-A21
171	AD61-11036A	CHASSIS-BOTTOM;- ,STS,- ,T0.6,-,-,VP-A20	
172	AD61-11037A	CHASSIS-TOP;- ,STS,- ,T0.6,-,-,VP-A20	
175	AD98-11242F	ASSY-CASE TOP;VP-A20,-	
180	AD90-10826L	ASSY-LENS;VP-A20/XEU,LENS	
181	AC29-92002D	FILTER-OLP;SV-3C01MM,KSS,-,-	
182	AC63-62007A	SPACER-CCD;SILICON,- ,BLK,- ,VP-K70,-	
183	AD61-11035A	BRACKET-LENS;- ,STS,- ,T0.6,-,-,VP-A20	
187	AD90-10824H	ASSY-CCD;A2-PJ,PAL	
901	AC60-10055A	SCREW-TAPPING;BH,+,-,M2,X4,FZB	
903	AC60-10054A	SCREW-TAPPING;BH,+,-,M2,X6,FZB	
905	AC60-10024A	SCREW-MACHINE;BH,+ ,M2,X3,FZW,FE,-,-,-	
906	AC60-12128A	SCREW-TAP TITE BH;- ,BH,4 1.7,I4,- ,FE,BLK	
W501	AD90-10832B	ASSY-FPC DECK;VP-A20,DECK	
W502	AD90-10808D	ASSY-FPC PRE-AMP;VP-A57/SEG,VCR-MAIN	

## 6-4 Mechanical Parts (1)

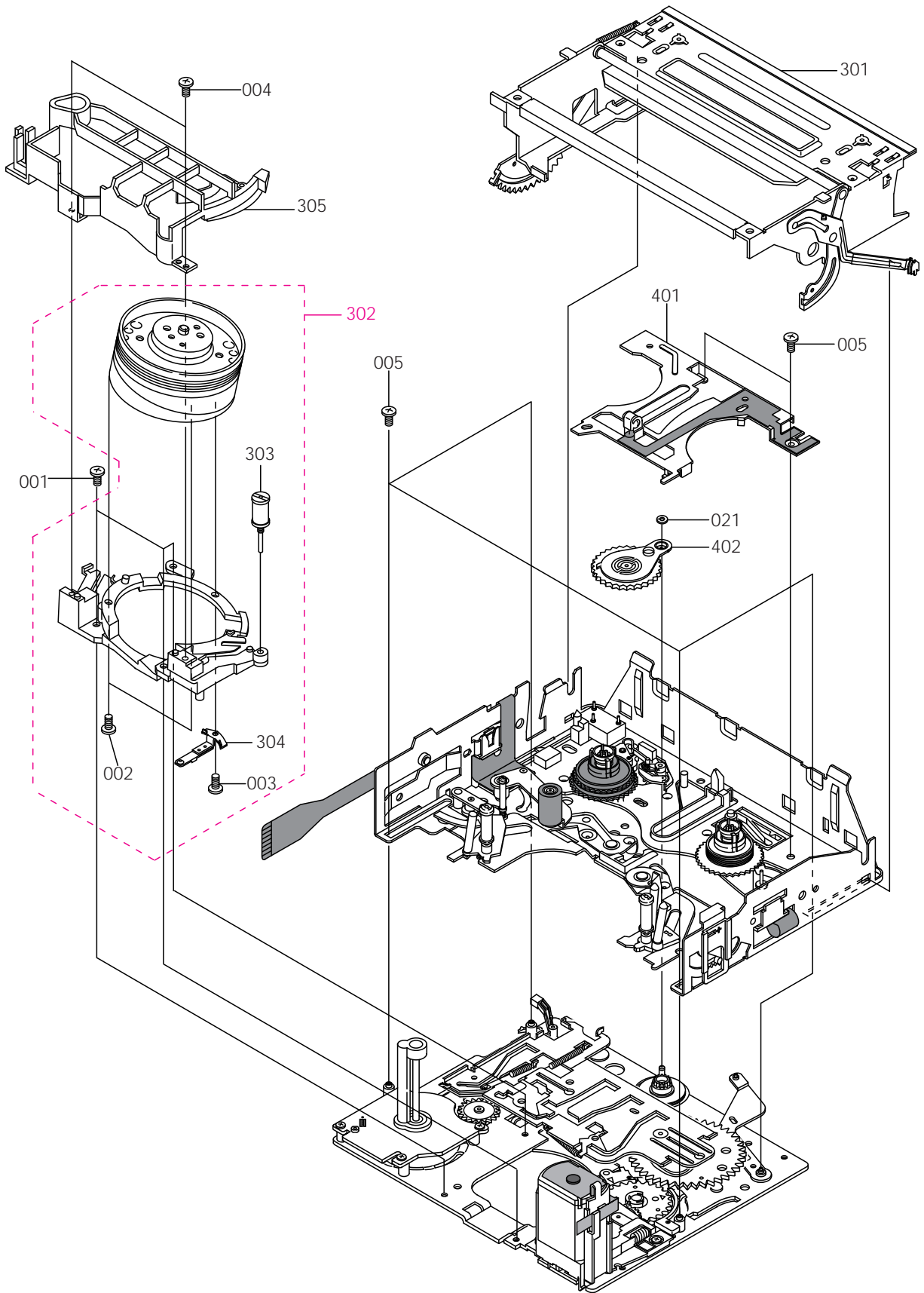

Loc. No	New Part No	Description and Specification	Remark
001	AC60-12083A	SCREW-MACHINE;B,BH,-,M1.7,L5,FE,WHT,-,-	
002	AD60-10500E	SCREW-MACHINE;- ,BWSH,+ ,UP,M2,L5,ZPCNYLOK	
003	AD60-10500D	SCREW-MACHINE;- ,BWSH,+ ,UP,M2,L7,ZPCNYLOK	
004	AC60-10017A	SCREW-MACHINE;BH,+ ,M1.7,X3.5,FEFZY,SWCH1	
005	AC60-12112A	SCREW-BH;- ,BH,+ ,M1.4,L2,-	
021	AC60-30015A	WASHER-SLIT;ID 1.1,OD 2.6,T 0.4,POLYSLID	
301	AD96-10473P	ASSY-HOUSING;DE-6B,-	
302	AD96-10473S	ASSY-DRUM;DE-6B,PN-SS	
303	AD66-40153A	ROLLER-IMP ASS'Y;- ,YF-10,OD7,- ,DE-6	
304	AC61-72009A	CONTACT-EARTH BRUSH;SECC/PBSP/CR/C,-,-,-,-	
305	AC63-32091A	COVER-DRUM;DURACON(M90-44),-,-,-,-,-,DE-	
401	AC63-30009A	COVER-REEL ASSY;ABS 95,HB,-,-,-,-,DE-6,-	
402	AC66-12035A	IDLER-ASSY;-,-,DE-6	

## 6-5 Mechanical Parts (2)

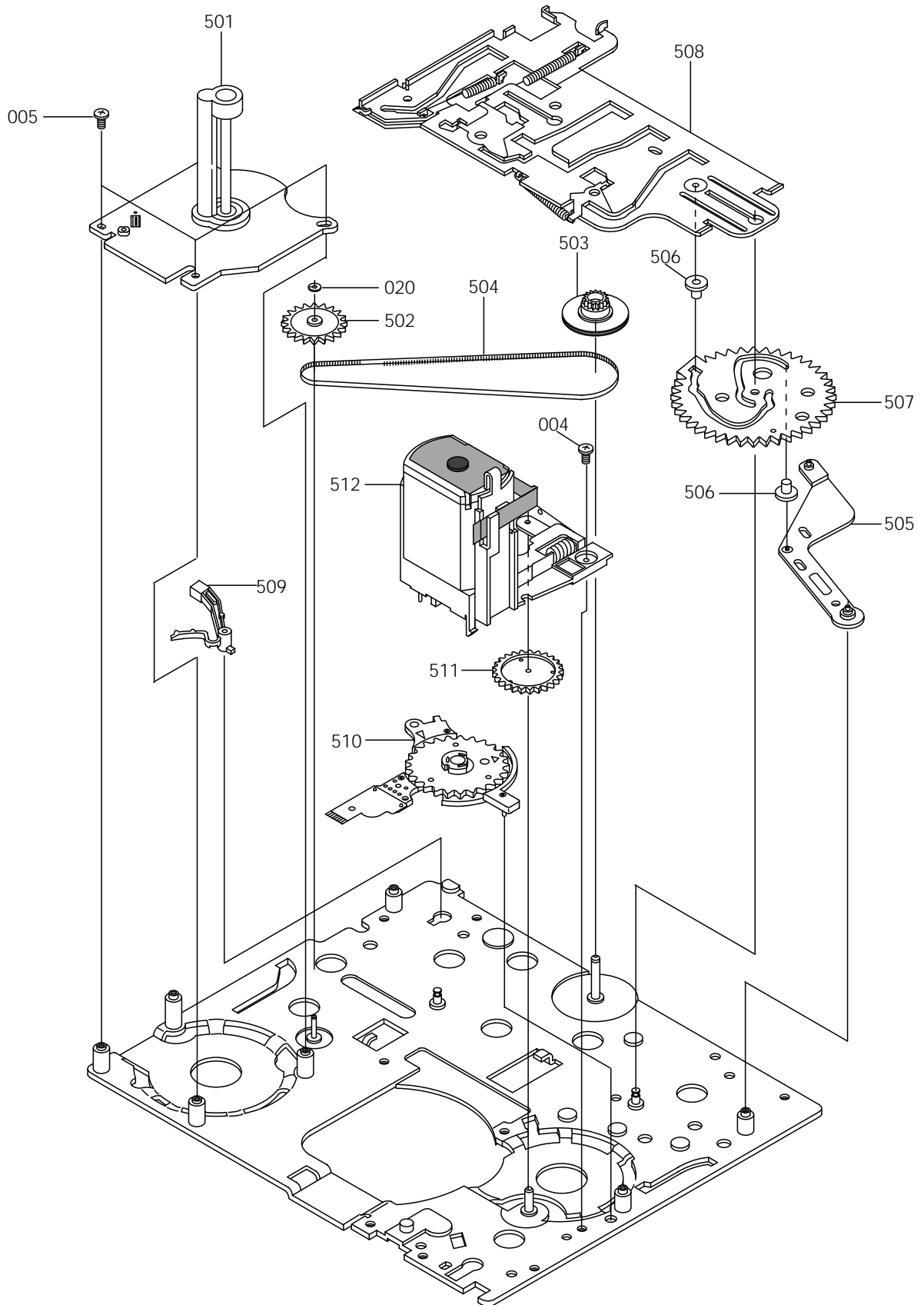

Loc. No	New Part No	Description and Specification	Reamrk
004	AC60-10017A	SCREW-MACHINE;BH,+ ,M1.7,X3.5,FEFZY,SWCH1	
005	AC60-12112A	SCREW-BH;- ,BH,+ ,M1.4,L2,-	
020	AC60-30017A	WASHER-SLIT;ID 1,OD 2.6,T 0.4,POLYSLIDER	
501	AD31-12010A	MOTOR-CAPSTAN;DE-6B SHS,-,-	
502	AC66-22123A	GEAR-CAPSTAN(ASSY);-,-,-,-,-,DE-6	
503	AC66-22124A	GEAR-PULLEY(ASSY);-,-,-,-,-,DE-6	
504	AC66-62001A	BELT-TIMMING;POLYURETHAN,L137 T0.4,-,-,-	
505	AC66-32197A	LEVER-CAM;SUS430-CP,T0.6,-,-,-,DE-6,-	
506	AC66-42005A	ROLLER-CAM MAIN;SUS303,-,-,PI3.5X1.1	
507	AC66-22092A	GEAR-CAM MAIN;SUS304-CSP,M0.5,Z64,-,-,-,-	
508	AC66-82055A	SLIDER-MAIN(ASSY);-,-,-,-,-,DE-6	
509	AC66-32198A	LEVER-EJECT;DURANEX #3300,-,-,-,-,DE-6,-	
510	AC34-22001C	SWITCH-MODE ASSY;HMW0484-01WA,DE-6,-,-,-,-	
511	AC66-22126A	GEAR-LOADING;DURACON(99-44),M0.4,Z37 WO,	
512	AC31-12001P	MOTOR-LOADING ASSY;DE-6,-,-,-	

## 6-6 Mechanical Parts (3)

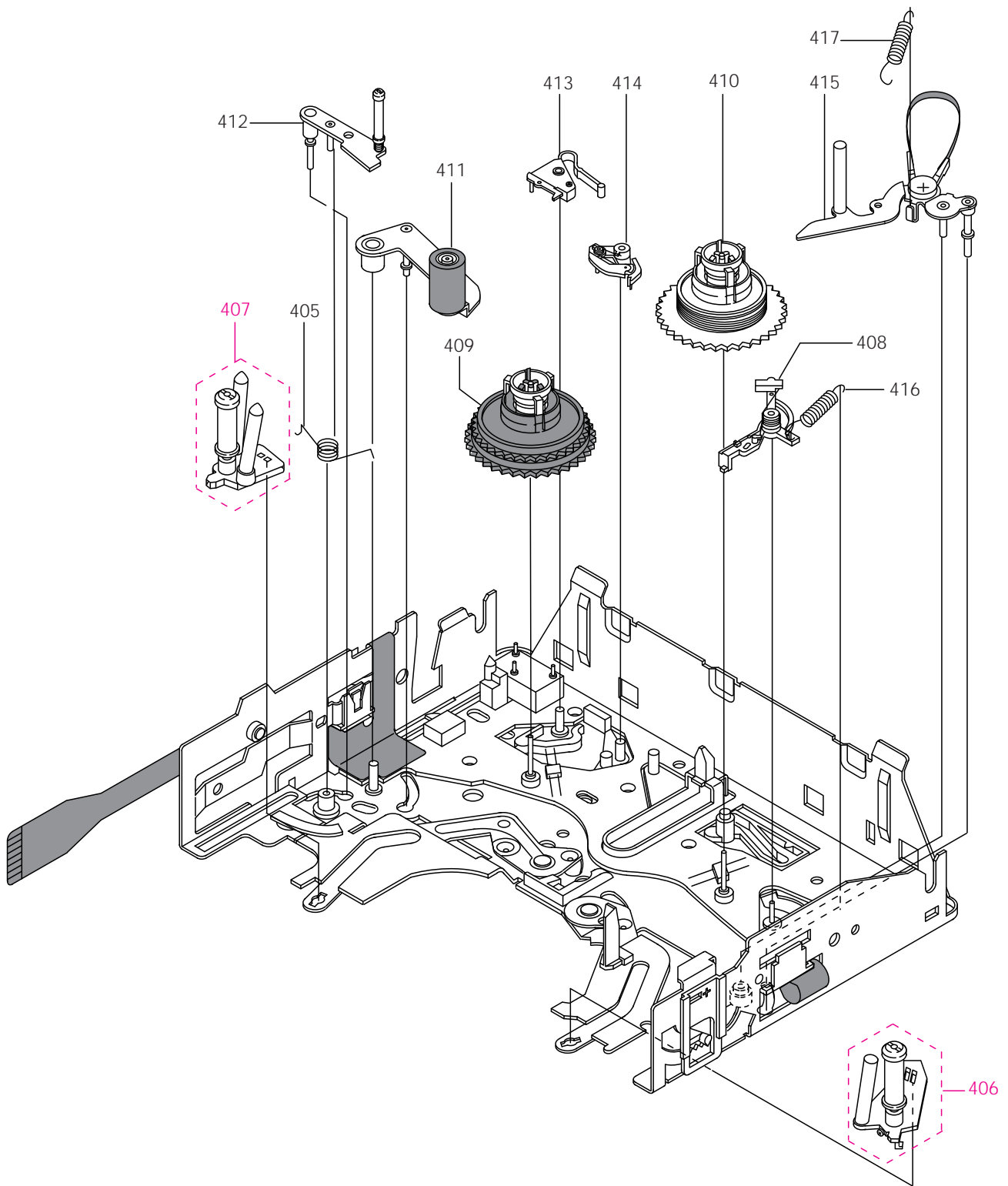

Loc. No	New Part No	Description and Specification	Remark
405	62724-0278-00	SPRING-REVIEW ARM;PS SUS304-WPB PI0.3	
406	AC61-52014A	POLE-BASE S(ASSY);ZDC2/SUS303,-,-,-,-,DE	
407	AC61-52015A	POLE-BASE T(ASSY);ZDC2/SUS303,-,-,-,-,DE	
408	AC66-32221A	BRAKE-SUB S(ASSY);-,-,-,-,DE-6,-	
409	AC66-12042A	REEL-T(ASSY);-,-,-,DE-6	
410	AC66-12041A	REEL-S(ASSY);-,-,-,DE-6	
411	AC66-32217A	ARM-PINCH ROLLER(ASS;-,-,-,-,DE-6	
412	AC66-32213A	ARM-REVIEW ASSY;-,-,-,-,DE-6	
413	AC66-32223A	BRAKE-MAIN(T);DURACON(M904-44),-,-,-,-,-	
414	AC66-30120A	BRAKE-SOFT T (ASSY);-,-,-,-,DE-6,-	
415	AC66-30093A	ARM-TENSION (ASSY);SUS304-CSP POM FELT,-	
416	AC61-62022A	SPRING-SOFT BRAKE(S);-,SUS304,-,-,-,-,-	
417	AC61-62023A	SPRING-TENSION;-,-,SUS304-WPB,-,-,-,-,-	

### 6-7 EVF (VP-A20/VP-A22)

---

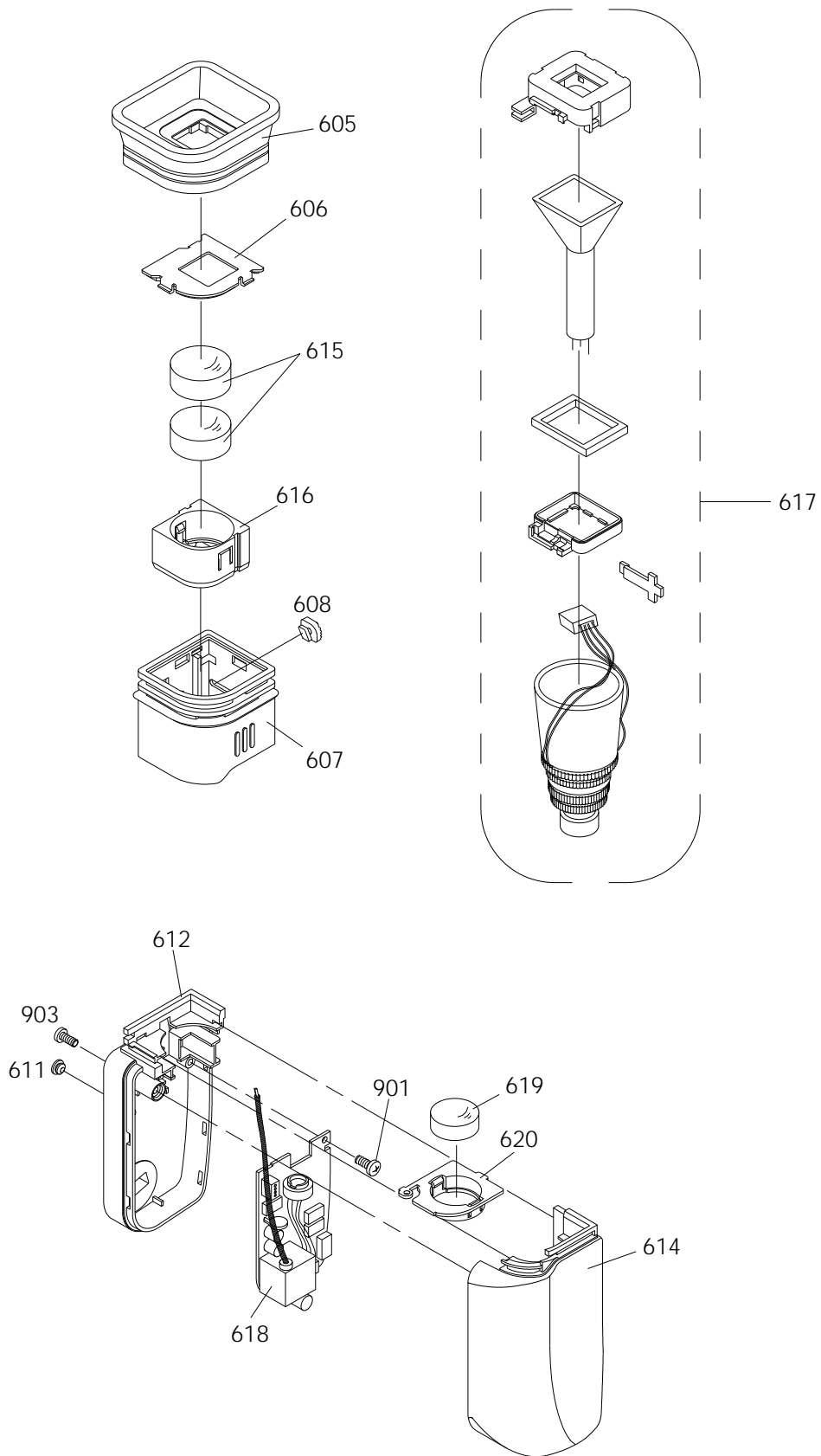

Loc. No	New Part No	Description and Specification	Remark
605	AD73-10035A	RUBBER-EYE CUP;SILICON,-,VP-A20,-	
606	AD61-50724A	GUIDE-CAP;- ,ABS94,HB,-,-,VP-A20	
607	AD61-50725A	GUIDE-EYE LENS;- ,ABS94,HB,-,-,VP-A20	
608	AD64-10845A	KNOB-EVF;- ,ABS94,HB,-,-,VP-A20	
611	AD61-20918A	CAP-FOCUS;- ,MBR,-,BLK,-,VP-K70	
612	AD64-30934A	CASE-EVF R;- ,ABS94,V0,-,-,-,VP-A20	
614	AD64-30933A	CASE-EVF L;- ,ABS94,V0,-,-,-,VP-A20	VP-A20
614	AD64-30933C	CASE-EVF L;- ,ABS94,V0,-,-,-,B/W,VP-A22	VP-A22
615	AC67-12070A	LENS-EVF(MD);PMMA D19.1 ASP,-,-,-,-	
616	AD61-22017A	HOLDER-EYE LENS A;- ,ABS94,HB,-,-,VP-A20	
617	AC90-10012V	ASSY-CRT;CS96(SPORTS),-	
618	AD90-10822T	ASSY-EVF BOARD;A2-P/J,PAL	
619	AC67-10066A	LENS-EVF GJ;- ,OPT,GRASS-F1,D11.5,-,CG819	
620	AD61-21083A	HOLDER-EYE LENS B;- ,ABS94,HB,-,-,VP-A20	
901	AC60-10055A	SCREW-TAPPING;BH,+,-,M2,X4,FZB	
903	AC60-10054A	SCREW-TAPPING;BH,+,-,M2,X6,FZB	

## 6-8 CVF (VP-A21/A23)

---

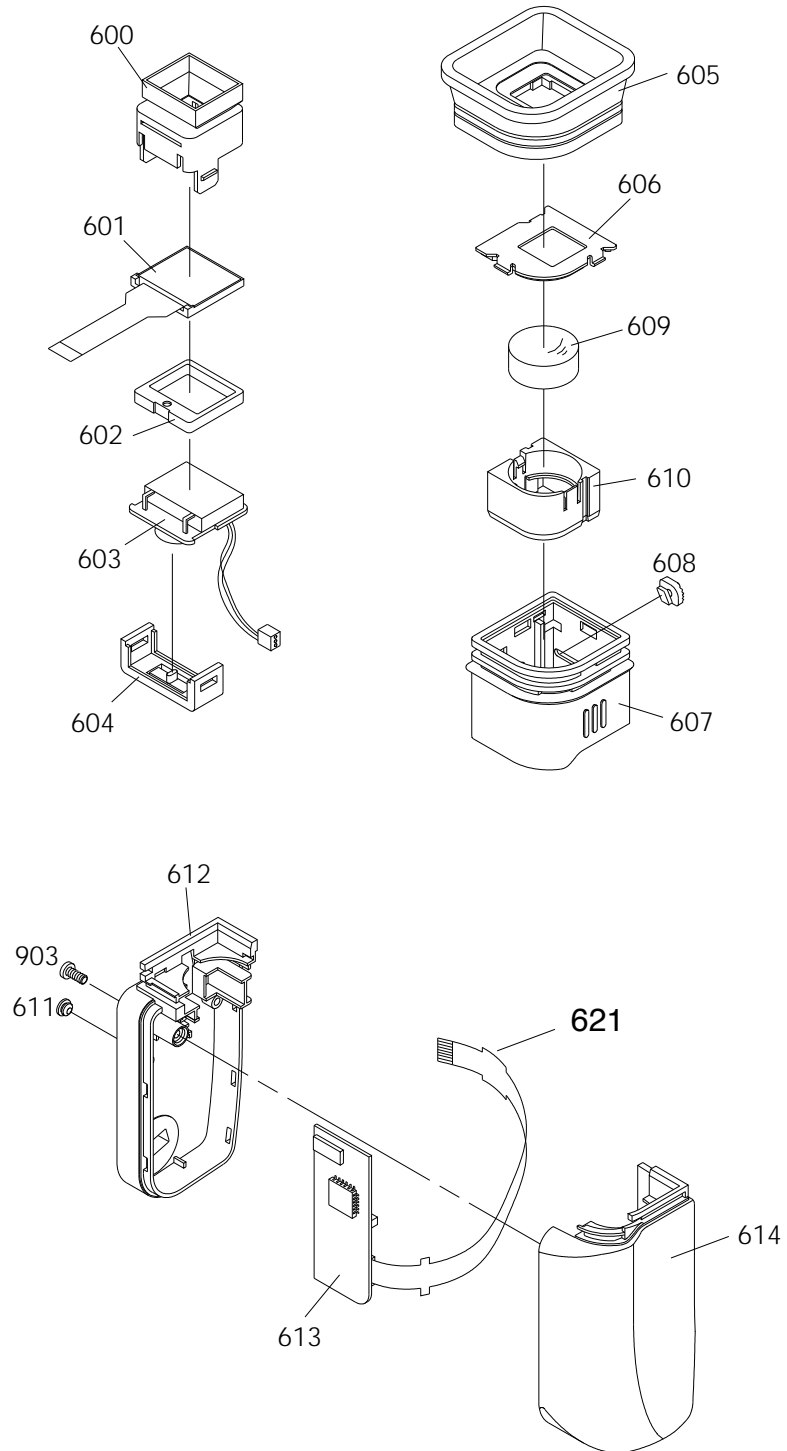

Loc. No	New Part No	Description and Specification	Remark
600	AD61-21084A	HOLDER-LCD;-;PC/ABS,V0,-,-,VP-A20	
601	AC07-10001L	LCD DISPLAY;LCX005BKB,COLOR,537*222,0.5	
602	AD61-50708A	GUIDE-LIGHT;-;ABS94VO,-,T1.5,BLK,-,SV-S9	
603	AD90-10815L	ASSY-B/L BOARD;SV-S99,NTSC	
604	AD61-21045A	HOLDER-LIGHT;-;ABS94,HB,BLK,-,SV-S99	
605	AD73-10035A	RUBBER-EYE CUP;SILICON,-,VP-A20,-	
606	AD61-50724A	GUIDE-CAP;-;ABS94,HB,-,-,-,VP-A20	
607	AD61-50725A	GUIDE-EYE LENS;-;ABS94,HB,-,-,-,VP-A20	
608	AD64-10845A	KNOB-EVF;-;ABS94,HB,-,-,VP-A20	
609	66463-605-910	LENS EVF;PMMA CLR	
610	AD61-21082A	HOLDER-LENS;-;ABS94,HB,-,-,VP-A20/SEUK	
611	AD61-20918A	CAP-FOCUS;-;MBR,-,BLK,-,VP-K70	
612	AD64-30934A	CASE-EVF R;-;ABS94,V0,-,-,-,VP-A20	
613	AD90-10828V	ASSY-CVF BOARD;VP-A20,A2-CVF-PAL	
614	AD64-30933D	CASE-EVF L;-;ABS94,V0,-,-,-,COL,VP-A23	VP-A23
614	AD64-30933N	CASE-EVF L;VP-A21	VP-A21
621	AD41-20301B	FPC-CVF;POLYIMIDE,T0.18,12P,VP-A57	
903	AC60-10054A	SCREW-TAPPING;BH,+,-,M2,X6,FZB	

# MEMO

## 7. Electrical Parts List

Loc.No	Part No	Desc & Spec	Remark	Loc.No	Part No	Desc & Spec	Remark
140	AD90-10823B	ASSY-MAIN BOARD;VP-A20,PAL	VP-A20	R851	2007-000124	R-CHIP:2.2Kohm,5%,1/16W,DA,TP,1608	
140	AD90-10833A	ASSY-MAIN BOARD;VP-A22,PAL	VP-A22	R852	2007-000100	R-CHIP:68Kohm,5%,1/16W,DA,TP,1608	
140	AD90-10832Z	ASSY-MAIN BOARD;VP-A23,PAL	VP-A23	R853	2007-000078	R-CHIP:1Kohm,5%,1/16W,DA,TP,1608	
140	AD90-10839U	ASSY-MAIN BOARD;VP-A21,PAL	VP-A21	R854	2007-000122	R-CHIP:1.2Kohm,5%,1/16W,DA,TP,1608	
<b>AUDIO BLOCK</b>				R855	2007-000100	R-CHIP:68Kohm,5%,1/16W,DA,TP,1608	
C701	2404-000250	C-TA,CHIP:470nF,20%,25V,-,TP,3216,-		R856	2007-000125	R-CHIP:3.9Kohm,5%,1/16W,DA,TP,1608	
C702	2404-000250	C-TA,CHIP:470nF,20%,25V,-,TP,3216,-		R857	2007-000122	R-CHIP:1.2Kohm,5%,1/16W,DA,TP,1608	
C703	2402-001013	C-AL,SMD:47uF,20%,6.3V,GP5.3x1.5x5.4,1		R858	2007-000070	R-CHIP:0ohm,5%,1/16W,DA,TP,1608	
C704	2203-000257	C-CERAMIC,CHIP:10nF,10%,50V,X7R,1608,-,T		R859	2007-000075	R-CHIP:220ohm,5%,1/16W,DA,TP,1608	
C705	2404-000367	C-TA,CHIP:4.7uF,20%,6.3V,-,TP,3216,-		R860	2007-000655	R-CHIP:27Kohm,5%,1/16W,DA,TP 200	
C706	2203-000919	C-CERAMIC,CHIP:470nF,+80-20%,16V,Y5V,TP		R861	2007-000124	R-CHIP:2.2Kohm,5%,1/16W,DA,TP,1608	
C707	2404-000139	C-TA,CHIP:10uF,20%,6.3V,-,3216,-,TP		R862	2007-000094	R-CHIP:22Kohm,5%,1/16W,DA,TP,1608	
C708	2404-000367	C-TA,CHIP:4.7uF,20%,6.3V,-,TP,3216,-		R863	2007-000450	R-CHIP:180ohm,5%,1/16W,DA,TP,1608	
C709	2203-000257	C-CERAMIC,CHIP:10nF,10%,50V,X7R,1608,-,T		R864	2007-000078	R-CHIP:1Kohm,5%,1/16W,DA,TP,1608	
C710	2203-001103	C-CERAMIC,CHIP:6.8nF,10%,50V,X7R,TP,1608		R865	2007-000084	R-CHIP:4.7Kohm,5%,1/16W,DA,TP,1608	
C711	2203-000257	C-CERAMIC,CHIP:10nF,10%,50V,X7R,1608,-,T		R866	2007-000078	R-CHIP:1Kohm,5%,1/16W,DA,TP,1608	
C712	2203-000257	C-CERAMIC,CHIP:10nF,10%,50V,X7R,1608,-,T		<b>CAMERA MAIN BLOCK</b>			
C713	2203-000257	C-CERAMIC,CHIP:10nF,10%,50V,X7R,1608,-,T		CNP01	3710-001110	CONNECTOR-SOCKET:18P2R,0.8MM,SMD-S,AU	
C714	2203-001607	C-CERAMIC,CHIP:220pF,5%,50V,CH,1608,1.6mm		CNP02	3708-001262	CONNECTOR-FPC/FC/PIC:22P0.5mm,SMD-A,SN	
C715	2203-001556	C-CERAMIC,CHIP:100nF,+80-20%,25V,Y5V,TP		CNP03	3711-002049	CONNECTOR-HEADER:BOX,6P,1R,1.25mm,SMD-A,	
C716	2203-001556	C-CERAMIC,CHIP:100nF,+80-20%,25V,Y5V,TP		CP01	2203-001567	C-CERAMIC,CHIP:10pF,0.5pF,50V,CH,1608,1.	
C717	2203-000491	C-CERAMIC,CHIP:2.2nF,10%,50V,X7R,TP,1608		CP02	2203-000257	C-CERAMIC,CHIP:10nF,10%,50V,X7R,1608,-,T	
C718	2404-000367	C-TA,CHIP:4.7uF,20%,6.3V,-,TP,3216,-		CP05	2203-001573	C-CERAMIC,CHIP:12pF,5%,50V,CH,1608,1.6mm	
C719	2404-000139	C-TA,CHIP:10uF,20%,6.3V,-,3216,-,TP		CP06	2203-000257	C-CERAMIC,CHIP:10nF,10%,50V,X7R,1608,-,T	
C720	2404-000175	C-TA,CHIP:2.2uF,20%,6.3V,WT,3216,1.1mm,T		CP08	2203-001556	C-CERAMIC,CHIP:100nF,+80-20%,25V,Y5V,TP	
C721	2404-000259	C-TA,CHIP:47uF,20%,6.3V,-,TP,6032,-		CP09	2203-001588	C-CERAMIC,CHIP:18pF,5%,50V,CH,1608,1.6mm	
C722	2404-000198	C-TA,CHIP:22uF,20%,6.3V,-,TP,3528,-		CP10	2203-001567	C-CERAMIC,CHIP:10pF,0.5pF,50V,CH,1608,1.	
C723	2404-000250	C-TA,CHIP:470nF,20%,25V,-,TP,3216,-		CP11	2404-000198	C-TA,CHIP:22uF,20%,6.3V,-,TP,3528,-	
C726	2404-000259	C-TA,CHIP:47uF,20%,6.3V,-,TP,6032,-		CP12	2203-001556	C-CERAMIC,CHIP:100nF,+80-20%,25V,Y5V,TP	
C727	2404-000139	C-TA,CHIP:10uF,20%,6.3V,-,3216,-,TP		CP13	2203-001556	C-CERAMIC,CHIP:100nF,+80-20%,25V,Y5V,TP	
C851	2203-001556	C-CERAMIC,CHIP:100nF,+80-20%,25V,Y5V,TP		CP14	2203-001556	C-CERAMIC,CHIP:100nF,+80-20%,25V,Y5V,TP	
C852	2203-000715	C-CERAMIC,CHIP:3.3nF,10%,50V,X7R,TP,1608		CP18	2404-000159	C-TA,CHIP:1uF,20%,35V,-,TP,3528,-	
C853	2404-000151	C-TA,CHIP:1uF,20%,16V,-,TP,3216,-		CP20	2203-000477	C-CERAMIC,CHIP:1uF,+80-20%,16V,Y5V,TP,20	
C854	2404-000367	C-TA,CHIP:4.7uF,20%,6.3V,-,TP,3216,-		CP21	2404-000198	C-TA,CHIP:22uF,20%,6.3V,-,TP,3528,-	
C855	2404-000198	C-TA,CHIP:22uF,20%,6.3V,-,TP,3528,-		CP22	2203-001556	C-CERAMIC,CHIP:100nF,+80-20%,25V,Y5V,TP	
C856	2203-001662	C-CERAMIC,CHIP:5.6nF,10%,50V,CH,TP,1608		CP23	2203-001402	C-CERAMIC,CHIP:220nF,+80-20%,16V	
CN851	3711-002127	CONNECTOR-HEADER:BOX,8P,1R,1.25mm,SMD-A,		CP24	2404-000198	C-TA,CHIP:22uF,20%,6.3V,-,TP,3528,-	
IC701	1204-001307	IC-AUDIO PROCESSOR:LA7457W,QFP,64P,10MIL		CP25	2203-001556	C-CERAMIC,CHIP:100nF,+80-20%,25V,Y5V,TP	
L701	2703-000397	INDUCTOR-SMD:33uH,10%,2.5x2x1.8mm		CP26	2203-000477	C-CERAMIC,CHIP:1uF,+80-20%,16V,Y5V,TP,20	
Q701	0501-000218	TR-SMALL SIGNAL:2SC4081,NPN,200mW,UMT,TP		CP27	2203-000477	C-CERAMIC,CHIP:1uF,+80-20%,16V,Y5V,TP,20	
Q702	0501-000218	TR-SMALL SIGNAL:2SC4081,NPN,200mW,UMT,TP		CP28	2203-000440	C-CERAMIC,CHIP:1nF,10%,50V,X7R,1608,-,TP	
Q703	0501-000218	TR-SMALL SIGNAL:2SC4081,NPN,200mW,UMT,TP		CP29	2203-000440	C-CERAMIC,CHIP:1nF,10%,50V,X7R,1608,-,TP	
Q851	0501-000218	TR-SMALL SIGNAL:2SC4081,NPN,200mW,UMT,TP		CP30	2203-000491	C-CERAMIC,CHIP:2.2nF,10%,50V,X7R,TP,1608	
Q852	0506-000150	TR-ARRAY:UMX2N,NPN,2,50V,40V,100MA,300M		CP31	2203-001402	C-CERAMIC,CHIP:220nF,+80-20%,16V	
R701	2007-000134	R-CHIP:33Kohm,5%,1/16W,DA,TP,1608		CP34	2203-001559	C-CERAMIC,CHIP:100pF,5%,50V,NPO,TP,1608,	
R702	2007-000691	R-CHIP:3.3Mohm,5%,1/16W,DA,TP,1608		CP35	2404-000139	C-TA,CHIP:10uF,20%,6.3V,-,3216,-,TP	
R703	2007-000819	R-CHIP:390Kohm,5%,1/16W,DA,TP,1608		CP37	2404-000198	C-TA,CHIP:22uF,20%,6.3V,-,TP,3528,-	
R704	2007-000819	R-CHIP:390Kohm,5%,1/16W,DA,TP,1608		CP38	2203-001556	C-CERAMIC,CHIP:100nF,+80-20%,25V,Y5V,TP	
R705	2007-000078	R-CHIP:1Kohm,5%,1/16W,DA,TP,1608		CP39	2203-001556	C-CERAMIC,CHIP:100nF,+80-20%,25V,Y5V,TP	
R706	2007-000090	R-CHIP:10Kohm,5%,1/16W,DA,TP,1608		CP40	2203-001556	C-CERAMIC,CHIP:100nF,+80-20%,25V,Y5V,TP	
R707	2007-000070	R-CHIP:0ohm,5%,1/16W,DA,TP,1608		CP41	2203-001556	C-CERAMIC,CHIP:100nF,+80-20%,25V,Y5V,TP	
R708	2007-000133	R-CHIP:330Kohm,5%,1/16W,DA,TP,1608		CP42	2404-000139	C-TA,CHIP:10uF,20%,6.3V,-,3216,-,TP	
R710	2007-000070	R-CHIP:0ohm,5%,1/16W,DA,TP,1608		CP47	2404-000139	C-TA,CHIP:10uF,20%,6.3V,-,3216,-,TP	
R711	2007-000691	R-CHIP:3.3Mohm,5%,1/16W,DA,TP,1608		CP48	2203-000357	C-CERAMIC,CHIP:150pF,5%,50V,NPO,TP,1608,	
R712	2007-000102	R-CHIP:100Kohm,5%,1/16W,DA,TP,1608		CP50	2203-001402	C-CERAMIC,CHIP:220nF,+80-20%,16V	
R713	2007-000102	R-CHIP:100Kohm,5%,1/16W,DA,TP,1608		CP52	2203-001556	C-CERAMIC,CHIP:100nF,+80-20%,25V,Y5V,TP	
R714	2007-000124	R-CHIP:2.2Kohm,5%,1/16W,DA,TP,1608		CP53	2404-000139	C-TA,CHIP:10uF,20%,6.3V,-,3216,-,TP	
R717	2007-000450	R-CHIP:180ohm,5%,1/16W,DA,TP,1608		CP54	2203-001634	C-CERAMIC,CHIP:33nF,10%,50V,X7R,TP,1608,	
R720	2007-000124	R-CHIP:2.2Kohm,5%,1/16W,DA,TP,1608		CP55	2203-001402	C-CERAMIC,CHIP:220nF,+80-20%,16V	
R721	2007-000087	R-CHIP:6.8Kohm,5%,1/16W,DA,TP,1608		CP56	2203-001556	C-CERAMIC,CHIP:100nF,+80-20%,25V,Y5V,TP	
R722	2007-000462	R-CHIP:180ohm,5%,1/10W,DA,TP,2012		CP57	2203-001556	C-CERAMIC,CHIP:100nF,+80-20%,25V,Y5V,TP	
R723	2007-000450	R-CHIP:180ohm,5%,1/16W,DA,TP,1608		CP58	2404-000190	C-TA,CHIP:22uF,20%,16V,-,5832,-,TP	
R725	2007-000090	R-CHIP:10Kohm,5%,1/16W,DA,TP,1608		CP60	2404-000139	C-TA,CHIP:10uF,20%,6.3V,-,3216,-,TP	
R726	2007-000091	R-CHIP:12Kohm,5%,1/16W,DA,TP,1608		CP61	2203-000257	C-CERAMIC,CHIP:10nF,10%,50V,X7R,1608,-,T	
R728	2007-000103	R-CHIP:120Kohm,5%,1/16W,DA,TP,1608		CP62	2203-000257	C-CERAMIC,CHIP:10nF,10%,50V,X7R,1608,-,T	
R801	2007-000072	R-CHIP:47ohm,5%,1/16W,DA,TP,1608		CP63	2203-000257	C-CERAMIC,CHIP:10nF,10%,50V,X7R,1608,-,T	
R850	2007-000070	R-CHIP:0ohm,5%,1/16W,DA,TP,1608		CP64	2203-000715	C-CERAMIC,CHIP:3.3nF,10%,50V,X7R,TP,1608	

Electrical Parts List

Loc.No	Part No	Desc & Spec	Remark	Loc.No	Part No	Desc & Spec	Remark
CP65	2203-000715	C-CERAMIC,CHIP:3.3nF,10%,50V,X7R,TP,1608		ICS04	1201-000246	IC-OP AMP:3403,SOP,14P,173MIL,QUAD,20V/m	
CP66	2203-000715	C-CERAMIC,CHIP:3.3nF,10%,50V,X7R,TP,1608		ICZ01	AD14-10001N	IC-LOGIC:KS7314X,QFP,80P	
CP67	2203-001556	C-CERAMIC,CHIP:100nF,+80-20%,25V,Y5V,TP,		LP01	2703-000403	INDUCTOR-SMD:22uH,10%,3.2x2.5x2.2mm	
CP68	2203-000477	C-CERAMIC,CHIP:1uF,+80-20%,16V,Y5V,TP,20		LP03	2703-000397	INDUCTOR-SMD:33uH,10%,2.5x2x1.8mm	
CP69	2203-000257	C-CERAMIC,CHIP:10nF,10%,50V,X7R,1608,-,T		LP04	2703-000403	INDUCTOR-SMD:22uH,10%,3.2x2.5x2.2mm	
CP70	2203-000257	C-CERAMIC,CHIP:10nF,10%,50V,X7R,1608,-,T		LP05	2703-000403	INDUCTOR-SMD:22uH,10%,3.2x2.5x2.2mm	
CP71	2203-000257	C-CERAMIC,CHIP:10nF,10%,50V,X7R,1608,-,T		LP06	2703-000397	INDUCTOR-SMD:33uH,10%,2.5x2x1.8mm	
CP72	2203-000715	C-CERAMIC,CHIP:3.3nF,10%,50V,X7R,TP,1608		LP07	2703-000397	INDUCTOR-SMD:33uH,10%,2.5x2x1.8mm	
CP73	2203-000715	C-CERAMIC,CHIP:3.3nF,10%,50V,X7R,TP,1608		LP08	2703-000397	INDUCTOR-SMD:33uH,10%,2.5x2x1.8mm	
CP74	2203-000715	C-CERAMIC,CHIP:3.3nF,10%,50V,X7R,TP,1608		LP09	2703-000403	INDUCTOR-SMD:22uH,10%,3.2x2.5x2.2mm	
CP75	2203-000477	C-CERAMIC,CHIP:1uF,+80-20%,16V,Y5V,TP,20		LP10	2703-000397	INDUCTOR-SMD:33uH,10%,2.5x2x1.8mm	
CP78	2404-000212	C-TA,CHIP:3.3uF,20%,25V,-,3528,-,TP		LP12	2703-001494	INDUCTOR-SMD:100uH,5%,2.5x2.0x1.8	
CP80	2404-000212	C-TA,CHIP:3.3uF,20%,25V,-,3528,-,TP		LP13	2703-001494	INDUCTOR-SMD:100uH,5%,2.5x2.0x1.8	
CP81	2404-000139	C-TA,CHIP:10uF,20%,6.3V,-,3216,-,TP		LP15	2703-000397	INDUCTOR-SMD:33uH,10%,2.5x2x1.8mm	
CP82	2203-000477	C-CERAMIC,CHIP:1uF,+80-20%,16V,Y5V,TP,20		LP16	2703-000397	INDUCTOR-SMD:33uH,10%,2.5x2x1.8mm	
CP85	2203-001556	C-CERAMIC,CHIP:100nF,+80-20%,25V,Y5V,TP,		LZ01	2703-000397	INDUCTOR-SMD:33uH,10%,2.5x2x1.8mm	
CP86	2203-001556	C-CERAMIC,CHIP:100nF,+80-20%,25V,Y5V,TP,		LZ02	2703-000397	INDUCTOR-SMD:33uH,10%,2.5x2x1.8mm	
CP87	2203-001567	C-CERAMIC,CHIP:10pF,0.5pF,50V,CH,1608,1.		QP01	0501-000162	TR-SMALL SIGNAL:2SA1576,PNP,200mW,SC-70,	
CP88	2203-000384	C-CERAMIC,CHIP:15pF,5%,50V,NPO,TP,1608,-		QP02	0501-000162	TR-SMALL SIGNAL:2SA1576,PNP,200mW,SC-70,	
CP89	2203-001556	C-CERAMIC,CHIP:100nF,+80-20%,25V,Y5V,TP,		QP06	0504-000113	TR-DIGITAL:DTC144EUA,NPN,200mW,47K-47K,S	
CP90	2203-001556	C-CERAMIC,CHIP:100nF,+80-20%,25V,Y5V,TP,		QP07	0504-000113	TR-DIGITAL:DTC144EUA,NPN,200mW,47K-47K,S	
CP91	2203-001556	C-CERAMIC,CHIP:100nF,+80-20%,25V,Y5V,TP,		QP08	0504-000113	TR-DIGITAL:DTC144EUA,NPN,200mW,47K-47K,S	
CP92	2203-001556	C-CERAMIC,CHIP:100nF,+80-20%,25V,Y5V,TP,		RP01	2007-000070	R-CHIP:0ohm,5%,1/16W,DA,TP,1608	
CS01	2404-000139	C-TA,CHIP:10uF,20%,6.3V,-,3216,-,TP		RP02	2007-000090	R-CHIP:10Kohm,5%,1/16W,DA,TP,1608	
CS02	2203-001556	C-CERAMIC,CHIP:100nF,+80-20%,25V,Y5V,TP,		RP03	2007-000109	R-CHIP:1Mohm,5%,1/16W,DA,TP,1608	
CS03	2203-001556	C-CERAMIC,CHIP:100nF,+80-20%,25V,Y5V,TP,		RP05	2007-000070	R-CHIP:0ohm,5%,1/16W,DA,TP,1608	
CS04	2404-000139	C-TA,CHIP:10uF,20%,6.3V,-,3216,-,TP		RP06	2007-000070	R-CHIP:0ohm,5%,1/16W,DA,TP,1608	
CS05	2203-001556	C-CERAMIC,CHIP:100nF,+80-20%,25V,Y5V,TP,		RP08	2007-000122	R-CHIP:1.2Kohm,5%,1/16W,DA,TP,1608	
CS06	2203-001556	C-CERAMIC,CHIP:100nF,+80-20%,25V,Y5V,TP,		RP10	2007-000098	R-CHIP:56Kohm,5%,1/16W,DA,TP,1608	
CS07	2203-001402	C-CERAMIC,CHIP:220nF,+80-20%,16V		RP100	2007-000078	R-CHIP:1Kohm,5%,1/16W,DA,TP,1608	
CS08	2203-000054	C-CERAMIC,CHIP:15nF,0.150V,X7R,TP,1608,		RP101	2007-000102	R-CHIP:100Kohm,5%,1/16W,DA,TP,1608	
CS09	2404-001039	C-TA,CHIP:47uF,20%,6.3V,GP,TP,3528,-		RP11	2007-000250	R-CHIP:1.5Mohm,5%,1/16W,DA,TP,1608	
CS10	2404-001039	C-TA,CHIP:47uF,20%,6.3V,GP,TP,3528,-		RP12	2007-000074	R-CHIP:100ohm,5%,1/16W,DA,TP,1608	
CS11	2203-001630	C-CERAMIC,CHIP:330nF,+80-20%,16V		RP13	2007-000074	R-CHIP:100ohm,5%,1/16W,DA,TP,1608	
CS12	2203-001559	C-CERAMIC,CHIP:100pF,5%,50V,NPO,TP,1608,		RP14	2007-000074	R-CHIP:100ohm,5%,1/16W,DA,TP,1608	
CS13	2404-000198	C-TA,CHIP:22uF,20%,6.3V,-,TP,3528,-		RP15	2007-000077	R-CHIP:470ohm,5%,1/16W,DA,TP,1608	
CS14	2203-001556	C-CERAMIC,CHIP:100nF,+80-20%,25V,Y5V,TP,		RP16	2007-000077	R-CHIP:470ohm,5%,1/16W,DA,TP,1608	
CS15	2203-001556	C-CERAMIC,CHIP:100nF,+80-20%,25V,Y5V,TP,		RP17	2007-000077	R-CHIP:470ohm,5%,1/16W,DA,TP,1608	
CS16	2404-000139	C-TA,CHIP:10uF,20%,6.3V,-,3216,-,TP		RP18	2007-000077	R-CHIP:470ohm,5%,1/16W,DA,TP,1608	
CS17	2203-001556	C-CERAMIC,CHIP:100nF,+80-20%,25V,Y5V,TP,		RP19	2007-000077	R-CHIP:470ohm,5%,1/16W,DA,TP,1608	
CS18	2203-001556	C-CERAMIC,CHIP:100nF,+80-20%,25V,Y5V,TP,		RP20	2007-000077	R-CHIP:470ohm,5%,1/16W,DA,TP,1608	
CS19	2203-001402	C-CERAMIC,CHIP:220nF,+80-20%,16V		RP21	2007-000102	R-CHIP:100Kohm,5%,1/16W,DA,TP,1608	
CS20	2404-001039	C-TA,CHIP:47uF,20%,6.3V,GP,TP,3528,-		RP27	2007-000102	R-CHIP:100Kohm,5%,1/16W,DA,TP,1608	
CS21	2404-001039	C-TA,CHIP:47uF,20%,6.3V,GP,TP,3528,-		RP28	2007-000102	R-CHIP:100Kohm,5%,1/16W,DA,TP,1608	
CS22	2203-001630	C-CERAMIC,CHIP:330nF,+80-20%,16V		RP29	2007-000102	R-CHIP:100Kohm,5%,1/16W,DA,TP,1608	
CS23	2203-001559	C-CERAMIC,CHIP:100pF,5%,50V,NPO,TP,1608,		RP30	2007-000102	R-CHIP:100Kohm,5%,1/16W,DA,TP,1608	
CS24	2203-000054	C-CERAMIC,CHIP:15nF,0.150V,X7R,TP,1608,		RP31	2007-000402	R-CHIP:150ohm,5%,1/16W,DA,TP,1608	
CS25	2203-001556	C-CERAMIC,CHIP:100nF,+80-20%,25V,Y5V,TP,		RP32	2007-000124	R-CHIP:2.2Kohm,5%,1/16W,DA,TP,1608	
CS26	2203-000440	C-CERAMIC,CHIP:1nF,10%,50V,X7R,1608,-,TP		RP33	2007-000450	R-CHIP:180ohm,5%,1/16W,DA,TP,1608	
CTP501	3710-000413	CONNECTOR-SOCKET:14P,2R,0.8mm,STRAIGHT,S		RP34	2007-000402	R-CHIP:150ohm,5%,1/16W,DA,TP,1608	
CZ01	2404-000139	C-TA,CHIP:10uF,20%,6.3V,-,3216,-,TP		RP35	2007-001694	R-CHIP:1.2Kohm,5%,1/16W,DA,TP,1608	
CZ03	2404-000198	C-TA,CHIP:22uF,20%,6.3V,-,TP,3528,-		RP36	2007-000124	R-CHIP:2.2Kohm,5%,1/16W,DA,TP,1608	
CZ04	2203-001556	C-CERAMIC,CHIP:100nF,+80-20%,25V,Y5V,TP,		RP37	2007-000828	R-CHIP:39Kohm,1%,1/16W,DA,TP,1608	
DPO2	0405-000151	DIODE-VARACTOR:1T379,30V,10nA,USMD,TP		RP38	2007-000102	R-CHIP:100Kohm,5%,1/16W,DA,TP,1608	
DPO3	0405-000143	DIODE-VARACTOR:MA341,30V,10nA,MINI-2,TP		RP40	2007-000102	R-CHIP:100Kohm,5%,1/16W,DA,TP,1608	
DPO5	0401-000171	DIODE-SWITCHING:MA111,80V,100mA,-,3nS,SM		RP41	2007-000102	R-CHIP:100Kohm,5%,1/16W,DA,TP,1608	
DP10	0401-000171	DIODE-SWITCHING:MA111,80V,100mA,-,3nS,SM		RP42	2007-000512	R-CHIP:2.4Kohm,5%,1/16W,DA,TP,1608	
DP11	0401-000171	DIODE-SWITCHING:MA111,80V,100mA,-,3nS,SM		RP43	2007-000104	R-CHIP:150Kohm,5%,1/16W,DA,TP,1608	
ICP01	AD14-10001L	IC-LOGIC:KS7213,QFP,80P		RP44	2007-000094	R-CHIP:22Kohm,5%,1/16W,DA,TP,1608	
ICP02	1003-001065	IC-CLOCK DRIVER:KS7221D,SOP,20P,225MIL,Q		RP45	2007-000125	R-CHIP:3.9Kohm,5%,1/16W,DA,TP,1608	
ICP03	1002-001060	IC-A/D CONVERTER:TDA8786A,10BIT,QFP,48P,		RP46	2007-000125	R-CHIP:3.9Kohm,5%,1/16W,DA,TP,1608	
ICP04	AD14-10001V	IC-LOGIC:KS7306B,QFP,100P,REV		RP47	2007-000104	R-CHIP:150Kohm,5%,1/16W,DA,TP,1608	
ICP05	AD09-12002E	IC-MICOM:uPD784035GC-818-8BIT,QFP,2ND		RP48	2007-000134	R-CHIP:33Kohm,5%,1/16W,DA,TP,1608	
ICP06	1201-000246	IC-OP AMP:3403,SOP,14P,173MIL,QUAD,20V/m		RP49	2007-000102	R-CHIP:100Kohm,5%,1/16W,DA,TP,1608	
ICP07	1201-000246	IC-OP AMP:3403,SOP,14P,173MIL,QUAD,20V/m		RP50	2007-000134	R-CHIP:33Kohm,5%,1/16W,DA,TP,1608	
ICP08	AC14-12008D	IC-LOGIC:MPC17A85ZVM/SC111315,SOP,TAPE		RP51	2007-000090	R-CHIP:10Kohm,5%,1/16W,DA,TP,1608	
ICP09	AC14-12008D	IC-LOGIC:MPC17A85ZVM/SC111315,SOP,TAPE		RP53	2007-000075	R-CHIP:22Kohm,5%,1/16W,DA,TP,1608	
ICP10	AC11-12001G	IC-EEPROM:AT24C02N-10SC,QFP,-		RP54	2007-000078	R-CHIP:1Kohm,5%,1/16W,DA,TP,1608	
ICP11	AD14-10001H	IC-REGULATORS:TPS7233Q-PWLE,SSOP,8P		RP55	2007-000637	R-CHIP:270Kohm,5%,1/16W,DA,TP,1608	
ICP12	0801-000301	IC-CMOS LOGIC:7W04,INVERTER,SOP,8P,150MI		RP56	2007-000094	R-CHIP:22Kohm,5%,1/16W,DA,TP,1608	
ICS01	AC14-12007X	IC-LOGIC:TC4S66F,SSOP-5,5P		RP57	2007-000078	R-CHIP:1Kohm,5%,1/16W,DA,TP,1608	
ICS02	1201-000200	IC-OP AMP:3414,SOP,8P,173MIL,DUAL,-,PLAS		RP58	2007-000134	R-CHIP:33Kohm,5%,1/16W,DA,TP,1608	
ICS03	AC14-12007X	IC-LOGIC:TC4S66F,SSOP-5,5P		RP59	2007-000094	R-CHIP:22Kohm,5%,1/16W,DA,TP,1608	

Loc.No	Part No	Desc & Spec	Remark	Loc.No	Part No	Desc & Spec	Remark
RP63	2007-000096	R-CHIP:30Kohm,5%,1/16W,DA,TP,1608		C927	2203-000257	C-CERAMIC,CHIP:10nF,10%,50V,X7R,1608,-,T	
RP65	2007-000097	R-CHIP:47Kohm,5%,1/16W,DA,TP,1608		C928	2203-000257	C-CERAMIC,CHIP:10nF,10%,50V,X7R,1608,-,T	
RP66	2007-000100	R-CHIP:68Kohm,5%,1/16W,DA,TP,1608		C929	2203-001636	C-CERAMIC,CHIP:33pF,5%,50V,NPO,TP,1608,1	
RP67	2007-000102	R-CHIP:100Kohm,5%,1/16W,DA,TP,1608		C930	2203-000888	C-CERAMIC,CHIP:4.7nF,10%,50V,X7R,TP,1608	
RP68	2007-000863	R-CHIP:4.3ohm,5%,1/10W,DA,TP,2012		C931	2203-001636	C-CERAMIC,CHIP:33pF,5%,50V,NPO,TP,1608,1	
RP69	2007-000100	R-CHIP:68Kohm,5%,1/16W,DA,TP,1608		C932	2203-001632	C-CERAMIC,CHIP:330pF,5%,50V,CH,1608,1.6m	
RP70	2007-000100	R-CHIP:68Kohm,5%,1/16W,DA,TP,1608		C933	2203-001640	C-CERAMIC,CHIP:390PF,10%,50V,X7R,TP,1608	
RP71	2007-000863	R-CHIP:4.3ohm,5%,1/10W,DA,TP,2012		C934	2203-002220	C-CERAMIC,CHIP:56PF,5%,50V,CH,TP,1608,-	
RP72	2007-000102	R-CHIP:100Kohm,5%,1/16W,DA,TP,1608		C935	2203-001632	C-CERAMIC,CHIP:330pF,5%,50V,CH,1608,1.6m	
RP73	2007-000863	R-CHIP:4.3ohm,5%,1/10W,DA,TP,2012		C936	2203-001640	C-CERAMIC,CHIP:390PF,10%,50V,X7R,TP,1608	
RP74	2007-000100	R-CHIP:68Kohm,5%,1/16W,DA,TP,1608		C937	2203-001556	C-CERAMIC,CHIP:100nF,+80-20%,25V,Y5V,TP,	
RP75	2007-000100	R-CHIP:68Kohm,5%,1/16W,DA,TP,1608		C938	2203-001636	C-CERAMIC,CHIP:33pF,5%,50V,NPO,TP,1608,1	
RP76	2007-000863	R-CHIP:4.3ohm,5%,1/10W,DA,TP,2012		C940	2203-000512	C-CERAMIC,CHIP:2.2uF,+80-20%,16V,Y5V,321	
RP77	2007-000097	R-CHIP:47Kohm,5%,1/16W,DA,TP,1608		C941	2203-001103	C-CERAMIC,CHIP:6.8nF,10%,50V,X7R,TP,1608	
RP78	2007-000100	R-CHIP:68Kohm,5%,1/16W,DA,TP,1608		C942	2203-001103	C-CERAMIC,CHIP:6.8nF,10%,50V,X7R,TP,1608	
RP79	2007-000076	R-CHIP:330ohm,5%,1/16W,DA,TP,1608		C943	2203-001609	C-CERAMIC,CHIP:22NF,10%,16V,X7R,TP,1608,	
RP80	2007-000076	R-CHIP:330ohm,5%,1/16W,DA,TP,1608		C944	2203-000257	C-CERAMIC,CHIP:10nF,10%,50V,X7R,1608,-,T	
RP81	2007-000102	R-CHIP:100Kohm,5%,1/16W,DA,TP,1608		C945	2203-000257	C-CERAMIC,CHIP:10nF,10%,50V,X7R,1608,-,T	
RP85	2007-000102	R-CHIP:100Kohm,5%,1/16W,DA,TP,1608		C946	2203-000257	C-CERAMIC,CHIP:10nF,10%,50V,X7R,1608,-,T	
RP86	2007-000102	R-CHIP:100Kohm,5%,1/16W,DA,TP,1608		C949	2203-000477	C-CERAMIC,CHIP:1uF,+80-20%,16V,Y5V,TP,20	
RP89	2007-000102	R-CHIP:100Kohm,5%,1/16W,DA,TP,1608		C950	2203-000477	C-CERAMIC,CHIP:1uF,+80-20%,16V,Y5V,TP,20	
RP90	2007-000086	R-CHIP:5.6Kohm,5%,1/16W,DA,TP,1608		CN901	3711-002163	CONNECTOR-HEADER:3WALL,7P,1R,1.25mm,SMD-	
RP91	2007-000102	R-CHIP:100Kohm,5%,1/16W,DA,TP,1608		D901	0404-000150	DIODE-SCHOTTKY;EC10QS04,40V,1A,SMD,TP	
RP93	2007-000102	R-CHIP:100Kohm,5%,1/16W,DA,TP,1608		D902	0407-001013	DIODE-ARRAY;MA160A,80V,100mA,CX2,SOT-143	
RP95	2007-000070	R-CHIP:0ohm,5%,1/16W,DA,TP,1608		IC901	1203-000445	IC-POSI.FIXED REG.:14641,TO-220,3P,-,PLA	
RP96	2007-000070	R-CHIP:0ohm,5%,1/16W,DA,TP,1608		L901	2703-000402	INDUCTOR-SMD:1uH,20%,3.2x2.5x2.2mm	
RS01	2007-000781	R-CHIP:33ohm,5%,1/10W,DA,TP,2012		L902	2703-000408	INDUCTOR-SMD:3.3uH,20%,3.2x2.5x2.2mm	
RS02	2007-000094	R-CHIP:22Kohm,5%,1/16W,DA,TP,1608		L903	2703-000408	INDUCTOR-SMD:3.3uH,20%,3.2x2.5x2.2mm	
RS03	2007-000094	R-CHIP:22Kohm,5%,1/16W,DA,TP,1608		L904	2703-000414	INDUCTOR-SMD:22uH,20%,7x7x3.2mm	
RS04	2007-000094	R-CHIP:22Kohm,5%,1/16W,DA,TP,1608		L905	2703-000398	INDUCTOR-SMD:10uH,10%,3.2x2.5x2.2MM	
RS05	2007-000109	R-CHIP:1Mohm,5%,1/16W,DA,TP,1608		L906	2703-000398	INDUCTOR-SMD:10uH,10%,3.2x2.5x2.2MM	
RS06	2007-000092	R-CHIP:15Kohm,5%,1/16W,DA,TP,1608		L907	2703-000398	INDUCTOR-SMD:10uH,10%,3.2x2.5x2.2MM	
RS07	2007-000090	R-CHIP:10Kohm,5%,1/16W,DA,TP,1608		L908	2703-000398	INDUCTOR-SMD:10uH,10%,3.2x2.5x2.2MM	
RS08	2007-000109	R-CHIP:1Mohm,5%,1/16W,DA,TP,1608		L909	2703-000398	INDUCTOR-SMD:10uH,10%,3.2x2.5x2.2MM	
RS09	2007-001026	R-CHIP:560Kohm,5%,1/16W,DA,TP,1608		L910	2703-000398	INDUCTOR-SMD:10uH,10%,3.2x2.5x2.2MM	
RS10	2007-000097	R-CHIP:47Kohm,5%,1/16W,DA,TP,1608		L911	2703-000398	INDUCTOR-SMD:10uH,10%,3.2x2.5x2.2MM	
RS11	2007-000086	R-CHIP:5.6Kohm,5%,1/16W,DA,TP,1608		L912	2703-000398	INDUCTOR-SMD:10uH,10%,3.2x2.5x2.2MM	
RS13	2007-000094	R-CHIP:22Kohm,5%,1/16W,DA,TP,1608		L913	2703-001194	INDUCTOR-SMD:100uH,20%,7x7x3.2mm	
RS14	2007-000094	R-CHIP:22Kohm,5%,1/16W,DA,TP,1608		L914	2703-001194	INDUCTOR-SMD:100uH,20%,7x7x3.2mm	
RS15	2007-000094	R-CHIP:22Kohm,5%,1/16W,DA,TP,1608		L915	2703-000398	INDUCTOR-SMD:10uH,10%,3.2x2.5x2.2MM	
RS16	2007-000086	R-CHIP:5.6Kohm,5%,1/16W,DA,TP,1608		L917	2703-000399	INDUCTOR-SMD:100uH,10%,3.2x2.5x2.2mm	
RS17	2007-000109	R-CHIP:1Mohm,5%,1/16W,DA,TP,1608		L918	2703-000398	INDUCTOR-SMD:10uH,10%,3.2x2.5x2.2MM	
RS18	2007-000109	R-CHIP:1Mohm,5%,1/16W,DA,TP,1608		L919	2703-000399	INDUCTOR-SMD:100uH,10%,3.2x2.5x2.2mm	
RS19	2007-000090	R-CHIP:10Kohm,5%,1/16W,DA,TP,1608		Q901	0502-000432	TR-POWER:2SB1302-S,PNP,1.3W,SC-62,TP,14	
RS20	2007-000092	R-CHIP:15Kohm,5%,1/16W,DA,TP,1608		Q902	0504-000113	TR-DIGITAL-DTC144EUA,NPN,200mW,47K-47K,S	
RS21	2007-001026	R-CHIP:560Kohm,5%,1/16W,DA,TP,1608		Q903	0501-000172	TR-SMALL SIGNAL:2SB1121,PNP,500MW,PCP,TP	
RS22	2007-000097	R-CHIP:47Kohm,5%,1/16W,DA,TP,1608		Q904	0501-000681	TR-SMALL SIGNAL:FP101,PNP,1.3W,PCP4,TP,1	
RZ01	2007-000070	R-CHIP:0ohm,5%,1/16W,DA,TP,1608		Q905	0501-000681	TR-SMALL SIGNAL:FP101,PNP,1.3W,PCP4,TP,1	
XP01	2801-001428	CRYSTAL-SMD:28.375MHz,30ppm,28-ABL,7pF,6		Q906	0501-000172	TR-SMALL SIGNAL:2SB1121,PNP,500MW,PCP,TP	
XP02	2801-003347	CRYSTAL-UNIT:17.734475MHz,20ppm,28-ABN,8		Q907	0504-000113	TR-DIGITAL-DTC144EUA,NPN,200mW,47K-47K,S	
XP03	2801-003491	CRYSTAL-UNIT:32MHz,50ppm,28-ABL,9.2pF,60		Q908	0504-000107	TR-DIGITAL-DTA144EU,PNP,200mW,47K-47K,SC	
				Q909	0504-000107	TR-DIGITAL-DTA144EU,PNP,200mW,47K-47K,SC	
				Q910	0504-000113	TR-DIGITAL-DTC144EUA,NPN,200mW,47K-47K,S	
				R901	2007-000094	R-CHIP:22Kohm,5%,1/16W,DA,TP,1608	
				R902	2007-000094	R-CHIP:22Kohm,5%,1/16W,DA,TP,1608	
				R903	2007-001699	R-CHIP:120Kohm,0.5%,1/16W,DA,TP,1608	
				R904	2007-001694	R-CHIP:12Kohm,0.5%,1/16W,DA,TP,1608	
				R905	2007-007202	R-CHIP:51Kohm,0.5%,1/16W,DA,TP,1608	
				R906	2007-000094	R-CHIP:22Kohm,5%,1/16W,DA,TP,1608	
				R907	2007-007204	R-CHIP:5.1Kohm,0.5%,1/16W,DA,TP,1608	
				R908	2007-000766	R-CHIP:330ohm,5%,1/10W,DA,TP,2012	
				R910	2007-000086	R-CHIP:5.6Kohm,5%,1/16W,DA,TP,1608	
				R911	2007-000124	R-CHIP:2.2Kohm,5%,1/16W,DA,TP,1608	
				R912	2007-000086	R-CHIP:5.6Kohm,5%,1/16W,DA,TP,1608	
				R914	2007-000124	R-CHIP:2.2Kohm,5%,1/16W,DA,TP,1608	
				R915	2007-000101	R-CHIP:82Kohm,5%,1/16W,DA,TP,1608	
				R916	2007-000092	R-CHIP:15Kohm,5%,1/16W,DA,TP,1608	
				R917	2007-001643	R-CHIP:100Kohm,0.5%,1/16W,DA,TP,1608	
				R918	2007-001643	R-CHIP:100Kohm,0.5%,1/16W,DA,TP,1608	
				R919	2007-007203	R-CHIP:5.6Kohm,0.5%,1/16W,DA,TP,1608	
				R920	2007-000070	R-CHIP:0ohm,5%,1/16W,DA,TP,1608	
				R922	2007-000134	R-CHIP:33Kohm,5%,1/16W,DA,TP,1608	
				R923	2007-000078	R-CHIP:1Kohm,5%,1/16W,DA,TP,1608	
<b>DC/DC CONVERTER BLOCK</b>							
C901	2203-000477	C-CERAMIC,CHIP:1uF,+80-20%,16V,Y5V,TP,20					
C902	2203-000512	C-CERAMIC,CHIP:2.2uF,+80-20%,16V,Y5V,321					
C903	2404-000128	C-TA,CHIP:10uF,20%,16V,-,TP,6032,-					
C904	2203-001724	C-CERAMIC,CHIP:4.7uF,+80-20%,16V,Y5V,321					
C905	2404-000120	C-TA,CHIP:10uF,20%,10V,-,TP,3528,-					
C907	2203-000477	C-CERAMIC,CHIP:1uF,+80-20%,16V,Y5V,TP,20					
C908	2203-000477	C-CERAMIC,CHIP:1uF,+80-20%,16V,Y5V,TP,20					
C909	2203-000477	C-CERAMIC,CHIP:1uF,+80-20%,16V,Y5V,TP,20					
C910	2404-000120	C-TA,CHIP:10uF,20%,10V,-,TP,3528,-					
C912	2404-000120	C-TA,CHIP:10uF,20%,10V,-,TP,3528,-					
C915	2404-000120	C-TA,CHIP:10uF,20%,10V,-,TP,3528,-					
C916	2203-000512	C-CERAMIC,CHIP:2.2uF,+80-20%,16V,Y5V,321					
C917	2404-000120	C-TA,CHIP:10uF,20%,10V,-,TP,3528,-					
C920	2203-000481	C-CERAMIC,CHIP:1uF,+80-20%,25V,Y5V,TP,32					
C921	2203-000481	C-CERAMIC,CHIP:1uF,+80-20%,25V,Y5V,TP,32					
C922	2203-000512	C-CERAMIC,CHIP:2.2uF,+80-20%,16V,Y5V,321					
C923	2203-001556	C-CERAMIC,CHIP:100nF,+80-20%,25V,Y5V,TP,					
C924	2203-001556	C-CERAMIC,CHIP:100nF,+80-20%,25V,Y5V,TP,					
C925	2203-001559	C-CERAMIC,CHIP:100pF,5%,50V,NPO,TP,1608,					
C926	2203-000477	C-CERAMIC,CHIP:1uF,+80-20%,16V,Y5V,TP,20					

Electrical Parts List

Loc.No	Part No	Desc & Spec	Remark	Loc.No	Part No	Desc & Spec	Remark
R924	2007-001695	R-CHIP:22Kohm,0.5%,1/16W,DA,TP,1608		C553	2203-001556	C-CERAMIC,CHIP;100nF,+80-20%,25V,Y5V,TP,	
R925	2007-000090	R-CHIP:10Kohm,5%,1/16W,DA,TP,1608		C554	2203-001556	C-CERAMIC,CHIP;100nF,+80-20%,25V,Y5V,TP,	
R926	2007-000090	R-CHIP:10Kohm,5%,1/16W,DA,TP,1608		C555	2203-000477	C-CERAMIC,CHIP;1uF,+80-20%,16V,Y5V,TP,20	
R927	2007-001114	R-CHIP:680Kohm,5%,1/16W,DA,TP,1608		C601	2203-000477	C-CERAMIC,CHIP;1uF,+80-20%,16V,Y5V,TP,20	
R929	2007-000086	R-CHIP:5.6Kohm,5%,1/16W,DA,TP,1608		C602	2203-000477	C-CERAMIC,CHIP;1uF,+80-20%,16V,Y5V,TP,20	
R930	2007-000086	R-CHIP:5.6Kohm,5%,1/16W,DA,TP,1608		C603	2402-001009	C-AL,SMD;100UF,20%,6.3V,GP,TP5.3X5.3X5	
R931	2007-000090	R-CHIP:10Kohm,5%,1/16W,DA,TP,1608		C604	2203-001556	C-CERAMIC,CHIP;100nF,+80-20%,25V,Y5V,TP,	
R932	2007-000081	R-CHIP:2.7Kohm,5%,1/16W,DA,TP,1608		C605	2203-000477	C-CERAMIC,CHIP;1uF,+80-20%,16V,Y5V,TP,20	
R933	2007-000097	R-CHIP:47Kohm,5%,1/16W,DA,TP,1608		C606	2404-000232	C-TA,CHIP;4.7uF,20%,10V,WT,3216,-,TP	
R934	2007-000094	R-CHIP:22Kohm,5%,1/16W,DA,TP,1608		C608	2203-000257	C-CERAMIC,CHIP;10nF,10%,50V,X7R,1608,-,T	
R935	2007-000090	R-CHIP:10Kohm,5%,1/16W,DA,TP,1608		C609	2203-000626	C-CERAMIC,CHIP;22pF,5%,50V,NPO,TP,1608,-	
R936	2007-000655	R-CHIP:27Kohm,5%,1/16W,DA,TP 200		C610	2203-000626	C-CERAMIC,CHIP;22pF,5%,50V,NPO,TP,1608,-	
R937	2007-000101	R-CHIP:82Kohm,5%,1/16W,DA,TP,1608		C611	2203-000384	C-CERAMIC,CHIP;15pF,5%,50V,NPO,TP,1608,-	
R940	2007-000090	R-CHIP:10Kohm,5%,1/16W,DA,TP,1608		C612	2203-000384	C-CERAMIC,CHIP;15pF,5%,50V,NPO,TP,1608,-	
R941	2007-000090	R-CHIP:10Kohm,5%,1/16W,DA,TP,1608		C613	2203-000477	C-CERAMIC,CHIP;1uF,+80-20%,16V,Y5V,TP,20	
R942	2007-000090	R-CHIP:10Kohm,5%,1/16W,DA,TP,1608		C614	2203-001556	C-CERAMIC,CHIP;100nF,+80-20%,25V,Y5V,TP,	
R943	2007-000092	R-CHIP:15Kohm,5%,1/16W,DA,TP,1608		C615	2203-001556	C-CERAMIC,CHIP;100nF,+80-20%,25V,Y5V,TP,	
R944	2007-000090	R-CHIP:10Kohm,5%,1/16W,DA,TP,1608		C616	2203-000257	C-CERAMIC,CHIP;10nF,10%,50V,X7R,1608,-,T	
R945	2007-000090	R-CHIP:10Kohm,5%,1/16W,DA,TP,1608		C617	2203-000257	C-CERAMIC,CHIP;10nF,10%,50V,X7R,1608,-,T	
R946	2007-000090	R-CHIP:10Kohm,5%,1/16W,DA,TP,1608		C618	2203-000257	C-CERAMIC,CHIP;10nF,10%,50V,X7R,1608,-,T	
R947	2007-000092	R-CHIP:15Kohm,5%,1/16W,DA,TP,1608		C625	2203-000257	C-CERAMIC,CHIP;10nF,10%,50V,X7R,1608,-,T	
T901	AC26-22002C	TRANS-SWITCHING;CMS64,-,-,T,-,-,-		C626	2203-000477	C-CERAMIC,CHIP;1uF,+80-20%,16V,Y5V,TP,20	
<b>SYSCON/SERVO BLOCK</b>				C628	2404-001039	C-TA,CHIP;47uF,20%,6.3V,GP,TP,3528,-	
B601	AC29-32001B	FILTER-EMI BEAD;CB321611-TA SB 0.20H,-,-		CN501	3710-001301	CONNECTOR-SOCKET;48P,2R,0.8mm,SMD-S,SN	
C401	2203-001567	C-CERAMIC,CHIP;10pF,0.5pF,50V,CH,1608,1.		CN601	3710-001110	CONNECTOR-SOCKET;18P,2R,0.8MM,SMD-S,AU	
C402	2203-001573	C-CERAMIC,CHIP;12pF,5%,50V,CH,1608,1.6mm		CN603	3711-000456	CONNECTOR-HEADER;3WALL,4P,1R,1.25mm,SMD-	
C403	2404-000139	C-TA,CHIP;10uF,20%,6.3V,-,3216,-,TP		D402	0407-000115	DIODE-ARRAY;DAN202U,80V,100mA,CA	
C404	2203-001556	C-CERAMIC,CHIP;100nF,+80-20%,25V,Y5V,TP,		IC401	1204-001146	IC-OSD PROCESSOR;BU6251FV,SOP,20P,240MIL	
C421	2203-000257	C-CERAMIC,CHIP;10nF,10%,50V,X7R,1608,-,T		IC421	1002-001070	IC-D/A CONVERTER;M62353GP,8BIT,SOP,16P,-	
C501	2203-000257	C-CERAMIC,CHIP;10nF,10%,50V,X7R,1608,-,T		IC501	AC14-12005J	IC-LOGIC;KA8322,QFP,-	
C502	2203-000477	C-CERAMIC,CHIP;1uF,+80-20%,16V,Y5V,TP,20		IC502	1003-001012	IC-MOTOR DRIVER;LB1950,SOP,30P,300MIL,SI	
C503	2203-000477	C-CERAMIC,CHIP;1uF,+80-20%,16V,Y5V,TP,20		IC503	1003-001020	IC-MOTOR DRIVER;LB1951,SOP,24P,-,SINGLE,	
C504	2203-000888	C-CERAMIC,CHIP;4.7nF,10%,50V,X7R,TP,1608		IC504	1003-001146	IC-MOTOR DRIVER;LB1843VL,SOP,20P,-,800	
C505	2203-001609	C-CERAMIC,CHIP;22nF,10%,16V,X7R,TP,1608,		IC601	AD09-10452B	IC-MCU;CXP87240A-142Q,100P,QFP,VP-A20	
C506	2203-001609	C-CERAMIC,CHIP;22nF,10%,16V,X7R,TP,1608,		IC602	1203-001123	IC-VOLTAGE REGULATOR;8420,SOP,8P,216MIL,	
C507	2203-001559	C-CERAMIC,CHIP;100pF,5%,50V,NPO,TP,1608,		L401	2703-000397	INDUCTOR-SMD;33uH,10%,2.5x2x1.8mm	
C508	2203-001559	C-CERAMIC,CHIP;100pF,5%,50V,NPO,TP,1608,		L402	2703-000372	INDUCTOR-SMD;56uH,5%,2.5x2x1.8mm	
C509	2203-000062	C-CERAMIC,CHIP;1uF,+80-20%,16V,Y5V,TP,20		L421	2703-000397	INDUCTOR-SMD;33uH,10%,2.5x2x1.8mm	
C510	2203-000477	C-CERAMIC,CHIP;1uF,+80-20%,16V,Y5V,TP,20		L601	2703-000399	INDUCTOR-SMD;100uH,10%,3.2x2.5x2.2mm	
C511	2203-000062	C-CERAMIC,CHIP;47nF,+80-20%,50V,Y5V,1608		Q501	0501-000172	TR-SMALL SIGNAL;2SB1121,PNP,500MW,PCP,TP	
C512	2203-000257	C-CERAMIC,CHIP;10nF,10%,50V,X7R,1608,-,T		Q502	0504-000110	TR-DIGITAL;DTC114EU,NPN,200mW,10K-10Kohm	
C515	2203-001640	C-CERAMIC,CHIP;390pF,10%,50V,X7R,TP,1608		Q602	0504-000194	TR-DIGITAL;DTC124EU,NPN,200MW,22K-22K,SC	
C516	2203-000929	C-CERAMIC,CHIP;470pF,10%,50V,X7R,1608,-,		Q604	0501-000218	TR-SMALL SIGNAL;2SC4081,NPN,200mW,UMT,TP	
C517	2203-000062	C-CERAMIC,CHIP;47nF,+80-20%,50V,Y5V,1608		Q605	0504-000107	TR-DIGITAL;DTA144EU,PNP,200mW,47K-47K,SC	
C524	2203-000477	C-CERAMIC,CHIP;1uF,+80-20%,16V,Y5V,TP,20		R401	2007-000078	R-CHIP;1Kohm,5%,1/16W,DA,TP,1608	
C525	2203-000440	C-CERAMIC,CHIP;47nF,+80-20%,50V,X7R,1608,-,TP		R402	2007-000078	R-CHIP;1Kohm,5%,1/16W,DA,TP,1608	
C526	2203-000440	C-CERAMIC,CHIP;1nF,10%,50V,X7R,1608,-,TP		R403	2007-000078	R-CHIP;1Kohm,5%,1/16W,DA,TP,1608	
C527	2203-000477	C-CERAMIC,CHIP;1uF,+80-20%,16V,Y5V,TP,20		R404	2007-000078	R-CHIP;1Kohm,5%,1/16W,DA,TP,1608	
C528	2203-001556	C-CERAMIC,CHIP;100nF,+80-20%,25V,Y5V,TP,		R405	2007-000084	R-CHIP;4.7Kohm,5%,1/16W,DA,TP,1608	
C529	2203-001556	C-CERAMIC,CHIP;100nF,+80-20%,25V,Y5V,TP,		R406	2007-000080	R-CHIP;2Kohm,5%,1/16W,DA,TP,1608	
C530	2203-000257	C-CERAMIC,CHIP;10nF,10%,50V,X7R,1608,-,T		R407	2007-000078	R-CHIP;1Kohm,5%,1/16W,DA,TP,1608	
C531	2404-000151	C-TA,CHIP;1uF,20%,16V,-,TP,3216,-		R408	2007-000124	R-CHIP;2.2Kohm,5%,1/16W,DA,TP,1608	
C532	2203-000257	C-CERAMIC,CHIP;10nF,10%,50V,X7R,1608,-,T		R409	2007-000078	R-CHIP;1Kohm,5%,1/16W,DA,TP,1608	
C533	2203-001556	C-CERAMIC,CHIP;100nF,+80-20%,25V,Y5V,TP,		R410	2007-000078	R-CHIP;1Kohm,5%,1/16W,DA,TP,1608	
C534	2203-000062	C-CERAMIC,CHIP;47nF,+80-20%,50V,Y5V,1608		R412	2007-000084	R-CHIP;4.7Kohm,5%,1/16W,DA,TP,1608	
C535	2203-000888	C-CERAMIC,CHIP;4.7nF,10%,50V,X7R,TP,1608		R413	2007-000094	R-CHIP;22Kohm,5%,1/16W,DA,TP,1608	
C536	2203-001630	C-CERAMIC,CHIP;330nF,+80-20%,16V		R417	2007-000070	R-CHIP;0ohm,5%,1/16W,DA,TP,1608	
C537	2203-002218	C-CERAMIC,CHIP;47nF,10%,16V,X7R,TP,1608,		R501	2007-000090	R-CHIP;10Kohm,5%,1/16W,DA,TP,1608	
C538	2203-000491	C-CERAMIC,CHIP;2.2nF,10%,50V,X7R,TP,1608		R502	2007-000102	R-CHIP;100Kohm,5%,1/16W,DA,TP,1608	
C539	2203-000491	C-CERAMIC,CHIP;2.2nF,10%,50V,X7R,TP,1608		R503	2007-000065	R-CHIP;2.2Mohm,5%,1/16W,DA,TP,1608	
C540	2203-000491	C-CERAMIC,CHIP;2.2nF,10%,50V,X7R,TP,1608		R504	2007-000102	R-CHIP;100Kohm,5%,1/16W,DA,TP,1608	
C541	2203-001556	C-CERAMIC,CHIP;100nF,+80-20%,25V,Y5V,TP,		R505	2007-000102	R-CHIP;100Kohm,5%,1/16W,DA,TP,1608	
C542	2203-001556	C-CERAMIC,CHIP;100nF,+80-20%,25V,Y5V,TP,		R506	2007-000098	R-CHIP;56Kohm,5%,1/16W,DA,TP,1608	
C543	2203-001556	C-CERAMIC,CHIP;100nF,+80-20%,25V,Y5V,TP,		R507	2007-000094	R-CHIP;22Kohm,5%,1/16W,DA,TP,1608	
C544	2203-001556	C-CERAMIC,CHIP;100nF,+80-20%,25V,Y5V,TP,		R508	2007-001114	R-CHIP;680Kohm,5%,1/16W,DA,TP,1608	
C545	2203-001556	C-CERAMIC,CHIP;100nF,+80-20%,25V,Y5V,TP,		R509	2007-000123	R-CHIP;1.5Kohm,5%,1/16W,DA,TP,1608	
C546	2203-000199	C-CERAMIC,CHIP;100nF,+80-20%,50V,Z5U,TP,		R510	2007-000123	R-CHIP;1.5Kohm,5%,1/16W,DA,TP,1608	
C547	2402-000198	C-AL,SMD;47uF,20%,16V,GP,TP,6.3x5.4,-		R511	2007-000092	R-CHIP;15Kohm,5%,1/16W,DA,TP,1608	
C548	2203-000477	C-CERAMIC,CHIP;1uF,+80-20%,16V,Y5V,TP,20		R512	2007-000087	R-CHIP;6.8Kohm,5%,1/16W,DA,TP,1608	
C549	2404-000120	C-TA,CHIP;10uF,20%,10V,-,TP,3528,-		R513	2007-000076	R-CHIP;330ohm,5%,1/16W,DA,TP,1608	
C550	2203-001559	C-CERAMIC,CHIP;100pF,5%,50V,NPO,TP,1608,		R514	2007-000077	R-CHIP;470ohm,5%,1/16W,DA,TP,1608	
C552	2203-001556	C-CERAMIC,CHIP;100nF,+80-20%,25V,Y5V,TP,		R515	2007-000093	R-CHIP;20Kohm,5%,1/16W,DA,TP,1608	
				R516	2007-000093	R-CHIP;20Kohm,5%,1/16W,DA,TP,1608	



Electrical Parts List

Loc.No	Part No	Desc & Spec	Remark	Loc.No	Part No	Desc & Spec	Remark
C206	2203-000477	C-CERAMIC,CHIP:1uF,+80-20%,16V,Y5V,TP,20		C315	2203-001618	C-CERAMIC,CHIP:27pF,5%,50V,CH,1608,1.6mm	
C207	2203-000357	C-CERAMIC,CHIP:150pF,5%,50V,NPO,TP,1608,		C316	2203-000626	C-CERAMIC,CHIP:22pF,5%,50V,NPO,TP,1608,-	
C208	2203-001607	C-CERAMIC,CHIP:220pF,5%,50V,CH,1608,1.6mm		C317	2203-001658	C-CERAMIC,CHIP:47pF,5%,50V,CH,1608,1.6mm	
C209	2404-000198	C-TA,CHIP:22uF,20%,6.3V,-,TP,3528,-		C318	2203-000626	C-CERAMIC,CHIP:22pF,5%,50V,NPO,TP,1608,-	
C211	2203-001656	C-CERAMIC,CHIP:470pF,5%,50V,CH,1608,1.6mm		C319	2203-001559	C-CERAMIC,CHIP:100pF,5%,50V,NPO,TP,1608,	
C212	2404-000139	C-TA,CHIP:10uF,20%,6.3V,-,3216,-,TP		C320	2203-001658	C-CERAMIC,CHIP:47pF,5%,50V,CH,1608,1.6mm	
C214	2404-000139	C-TA,CHIP:10uF,20%,6.3V,-,3216,-,TP		C321	2203-001658	C-CERAMIC,CHIP:47pF,5%,50V,CH,1608,1.6mm	
C215	2203-000257	C-CERAMIC,CHIP:10nF,10%,50V,X7R,1608,-,T		C322	2203-001567	C-CERAMIC,CHIP:10pF,0.5pF,50V,CH,1608,1.	
C216	2404-000166	C-TA,CHIP:2.2uF,20%,10V,-,TP,3216,-		C323	2203-001567	C-CERAMIC,CHIP:10pF,0.5pF,50V,CH,1608,1.	
C217	2404-000166	C-TA,CHIP:2.2uF,20%,10V,-,TP,3216,-		C324	2203-001683	C-CERAMIC,CHIP:68PF,5%,50V,CH,TP,1608,1.	
C218	2404-000139	C-TA,CHIP:10uF,20%,6.3V,-,3216,-,TP		C325	2404-000139	C-TA,CHIP:10uF,20%,6.3V,-,3216,-,TP	
C219	2203-000477	C-CERAMIC,CHIP:1uF,+80-20%,16V,Y5V,TP,20		C326	2404-000139	C-TA,CHIP:10uF,20%,6.3V,-,3216,-,TP	
C220	2404-000139	C-TA,CHIP:10uF,20%,6.3V,-,3216,-,TP		C331	2203-001588	C-CERAMIC,CHIP:18pF,5%,50V,CH,1608,1.6mm	
C221	2203-000357	C-CERAMIC,CHIP:150pF,5%,50V,NPO,TP,1608,		C351	2203-000257	C-CERAMIC,CHIP:10nF,10%,50V,X7R,1608,-,T	
C222	2203-001588	C-CERAMIC,CHIP:18pF,5%,50V,CH,1608,1.6mm		C352	2404-000139	C-TA,CHIP:10uF,20%,6.3V,-,3216,-,TP	
C223	2404-000139	C-TA,CHIP:10uF,20%,6.3V,-,3216,-,TP		C353	2203-001568	C-CERAMIC,CHIP:110PF,5%,50V,CH,TP,1608,1	
C224	2203-000919	C-CERAMIC,CHIP:470nF,+80-20%,16V,Y5V,TP,		C354	2404-000232	C-TA,CHIP:4.7uF,20%,10V,WT,3216,-,TP	
C225	2203-000257	C-CERAMIC,CHIP:10nF,10%,50V,X7R,1608,-,T		C355	2203-000440	C-CERAMIC,CHIP:1nF,10%,50V,X7R,1608,-,TP	
C226	2404-000139	C-TA,CHIP:10uF,20%,6.3V,-,3216,-,TP		C356	2203-000440	C-CERAMIC,CHIP:1nF,10%,50V,X7R,1608,-,TP	
C227	2203-000477	C-CERAMIC,CHIP:1uF,+80-20%,16V,Y5V,TP,20		C357	2203-001640	C-CERAMIC,CHIP:390PF,10%,50V,X7R,TP,1608	
C228	2203-001402	C-CERAMIC,CHIP:220nF,+80-20%,16V		C358	2203-000477	C-CERAMIC,CHIP:1uF,+80-20%,16V,Y5V,TP,20	
C229	2404-000232	C-TA,CHIP:4.7uF,20%,10V,WT,3216,-,TP		C359	2203-000440	C-CERAMIC,CHIP:1nF,10%,50V,X7R,1608,-,TP	
C230	2402-001008	C-AL,SMD:220uF,20%,4V,-,6.6x6.6x5.4mm,2		C360	2203-000477	C-CERAMIC,CHIP:1uF,+80-20%,16V,Y5V,TP,20	
C231	2203-000257	C-CERAMIC,CHIP:10nF,10%,50V,X7R,1608,-,T		C361	2203-000257	C-CERAMIC,CHIP:10nF,10%,50V,X7R,1608,-,T	
C232	2404-001039	C-TA,CHIP:47uF,20%,6.3V,GP,TP,3528,-		C362	2203-000257	C-CERAMIC,CHIP:10nF,10%,50V,X7R,1608,-,T	
C233	2404-000139	C-TA,CHIP:10uF,20%,6.3V,-,3216,-,TP		C363	2203-001567	C-CERAMIC,CHIP:10pF,0.5pF,50V,CH,1608,1.	
C234	2203-000257	C-CERAMIC,CHIP:10nF,10%,50V,X7R,1608,-,T		CN101	3708-001243	CONNECTOR-FPC/FC/PIC:11P,1MM,SMD-A,SN	
C236	2203-000257	C-CERAMIC,CHIP:10nF,10%,50V,X7R,1608,-,T		D151	0407-000145	DIODE-ARRAY:DCC010,80V,100mA,C2-3,SOT-2	
C237	2203-000257	C-CERAMIC,CHIP:10nF,10%,50V,X7R,1608,-,T		D201	0407-000115	DIODE-ARRAY:DAN202U,80V,100mA,CA	
C238	2203-001559	C-CERAMIC,CHIP:100pF,5%,50V,NPO,TP,1608,		D202	0401-000171	DIODE-SWITCHING:MA111,80V,100mA,-,3nS,SMD	
C239	2203-001556	C-CERAMIC,CHIP:100nF,+80-20%,25V,Y5V,TP,		D203	0407-000102	DIODE-ARRAY:DA204U,20V,100MA,C2-3,SC-70,	
C241	2203-001658	C-CERAMIC,CHIP:47pF,5%,50V,CH,1608,1.6mm		D351	0401-000171	DIODE-SWITCHING:MA111,80V,100mA,-,3nS,SMD	
C242	2203-001568	C-CERAMIC,CHIP:110PF,5%,50V,CH,TP,1608,1		IC101	1201-001087	IC-PREAMP:52369,QFP,48P,-,SINGLE,-,PLAST	
C243	2203-000626	C-CERAMIC,CHIP:22pF,5%,50V,NPO,TP,1608,-		IC201	AC14-12012G	IC:CXA1700R,QFP,-	
C244	2203-000851	C-CERAMIC,CHIP:39PF,5%,50V,NPO,TP,1608,-		IC202	1201-001083	IC-AGC AMP:1211.SOP8P,225MIL,DUAL,5dB,P	
C245	2203-000440	C-CERAMIC,CHIP:1nF,10%,50V,X7R,1608,-,TP		IC203	AC14-12015G	IC-LINEAR:NJM2249V,SSOP,TAPE	
C246	2404-000151	C-TA,CHIP:1uF,20%,16V,-,TP,3216,-		IC302	1209-001044	IC-DELAY LINE:CXL5517N,SOP,20P,173MIL,PL	
C247	2203-001103	C-CERAMIC,CHIP:6.8nF,10%,50V,X7R,TP,1608		IC351	AC14-12012S	IC:M52358VP,SOP,-	
C248	2203-001609	C-CERAMIC,CHIP:22nF,10%,16V,X7R,TP,1608,		L101	2703-000399	INDUCTOR-SMD:100uH,10%,3.2x2.5x2.2mm	
C249	2404-000261	C-TA,CHIP:680nF,20%,20V,-,TP,3216,-		L102	2703-000397	INDUCTOR-SMD:33uH,10%,2.5x2x1.8mm	
C250	2203-000440	C-CERAMIC,CHIP:1nF,10%,50V,X7R,1608,-,TP		L103	2703-001493	INDUCTOR-SMD:10uH,5%,2.5x2.0x1.8	
C251	2203-000477	C-CERAMIC,CHIP:1uF,+80-20%,16V,Y5V,TP,20		L151	2703-000397	INDUCTOR-SMD:33uH,10%,2.5x2x1.8mm	
C254	2203-000257	C-CERAMIC,CHIP:10nF,10%,50V,X7R,1608,-,T		L152	2703-000385	INDUCTOR-SMD:330uH,5%,3.2x2.5x2.2mm	
C255	2404-000139	C-TA,CHIP:10uF,20%,6.3V,-,3216,-,TP		L153	2703-000416	INDUCTOR-SMD:100uH,5%,2.5x3.2x2.2mm	
C256	2203-000257	C-CERAMIC,CHIP:10nF,10%,50V,X7R,1608,-,T		L154	2703-000388	INDUCTOR-SMD:470uH,5%,3.2x2.5x2.2mm	
C257	2203-000257	C-CERAMIC,CHIP:10nF,10%,50V,X7R,1608,-,T		L155	2703-000381	INDUCTOR-SMD:180uH,5%,3.2x2.5x2.2mm	
C258	2404-000232	C-TA,CHIP:4.7uF,20%,10V,WT,3216,-,TP		L157	2703-000372	INDUCTOR-SMD:56uH,5%,2.5x2x1.8mm	
C259	2203-000257	C-CERAMIC,CHIP:10nF,10%,50V,X7R,1608,-,T		L158	2703-001493	INDUCTOR-SMD:10uH,5%,2.5x2.0x1.8	
C260	2404-000139	C-TA,CHIP:10uF,20%,6.3V,-,3216,-,TP		L202	2703-000409	INDUCTOR-SMD:47uH,10%,3.2x2.5x2.2mm	
C261	2203-001658	C-CERAMIC,CHIP:47pF,5%,50V,CH,1608,1.6mm		L203	2703-000403	INDUCTOR-SMD:22uH,10%,3.2x2.5x2.2mm	
C262	2404-000139	C-TA,CHIP:10uF,20%,6.3V,-,3216,-,TP		L205	2703-001494	INDUCTOR-SMD:100uH,5%,2.5x2.0x1.8	
C263	2203-001658	C-CERAMIC,CHIP:47pF,5%,50V,CH,1608,1.6mm		L206	2703-000385	INDUCTOR-SMD:330uH,5%,3.2x2.5x2.2mm	
C264	2404-000198	C-TA,CHIP:22uF,20%,6.3V,-,TP,3528,-		L208	2703-000366	INDUCTOR-SMD:22uH,5%,2.5x2x1.8mm	
C265	2203-000257	C-CERAMIC,CHIP:10nF,10%,50V,X7R,1608,-,T		L209	2703-000397	INDUCTOR-SMD:33uH,10%,2.5x2x1.8mm	
C266	2203-000257	C-CERAMIC,CHIP:10nF,10%,50V,X7R,1608,-,T		L210	2703-000397	INDUCTOR-SMD:33uH,10%,2.5x2x1.8mm	
C267	2203-000477	C-CERAMIC,CHIP:1uF,+80-20%,16V,Y5V,TP,20		L211	2703-000366	INDUCTOR-SMD:22uH,5%,2.5x2x1.8mm	
C268	2203-001658	C-CERAMIC,CHIP:47pF,5%,50V,CH,1608,1.6mm		L212	2703-000376	INDUCTOR-SMD:8.2uH,5%,2.5x2x1.8mm	
C269	2203-000062	C-CERAMIC,CHIP:47nF,+80-20%,50V,Y5V,1608		L301	2703-000397	INDUCTOR-SMD:33uH,10%,2.5x2x1.8mm	
C270	2203-001636	C-CERAMIC,CHIP:33pF,5%,50V,NPO,TP,1608,1		L302	2703-000397	INDUCTOR-SMD:33uH,10%,2.5x2x1.8mm	
C291	2404-000139	C-TA,CHIP:10uF,20%,6.3V,-,3216,-,TP		L303	2703-000367	INDUCTOR-SMD:33uH,5%,2.5x2x1.8mm	
C301	2404-000139	C-TA,CHIP:10uF,20%,6.3V,-,3216,-,TP		L304	2703-001493	INDUCTOR-SMD:10uH,5%,2.5x2.0x1.8	
C302	2203-000257	C-CERAMIC,CHIP:10nF,10%,50V,X7R,1608,-,T		L305	2703-001498	INDUCTOR-SMD:4.7uH,5%,2.5x2.0x1.8	
C303	2203-000477	C-CERAMIC,CHIP:1uF,+80-20%,16V,Y5V,TP,20		L306	2703-000367	INDUCTOR-SMD:33uH,5%,2.5x2x1.8mm	
C304	2203-000257	C-CERAMIC,CHIP:10nF,10%,50V,X7R,1608,-,T		L307	2703-001498	INDUCTOR-SMD:4.7uH,5%,2.5x2.0x1.8	
C306	2203-000477	C-CERAMIC,CHIP:1uF,+80-20%,16V,Y5V,TP,20		L351	2703-000403	INDUCTOR-SMD:22uH,10%,3.2x2.5x2.2mm	
C307	2203-000477	C-CERAMIC,CHIP:1uF,+80-20%,16V,Y5V,TP,20		Q102	0506-000148	TR-ARRAY:UMT2N,PNP,2,-50V,-40V,-100MA,3	
C308	2203-001556	C-CERAMIC,CHIP:100nF,+80-20%,25V,Y5V,TP,		Q151	0501-000218	TR-SMALL SIGNAL:2SC4081.NPN,200mW,UMT,TP	
C309	2203-000440	C-CERAMIC,CHIP:1nF,10%,50V,X7R,1608,-,TP		Q152	0501-000218	TR-SMALL SIGNAL:2SC4081.NPN,200mW,UMT,TP	
C310	2203-000440	C-CERAMIC,CHIP:1nF,10%,50V,X7R,1608,-,TP		Q154	0504-000107	TR-DIGITAL:DTA144EU.PNP,200mW,47K-47K,SC	
C311	2203-001588	C-CERAMIC,CHIP:18pF,5%,50V,CH,1608,1.6mm		Q156	0501-000207	TR-SMALL SIGNAL:2SC3142.NPN,150MW,SOT-23	
C312	2203-001618	C-CERAMIC,CHIP:27pF,5%,50V,CH,1608,1.6mm		Q157	0501-000218	TR-SMALL SIGNAL:2SC4081.NPN,200mW,UMT,TP	
C313	2203-001559	C-CERAMIC,CHIP:100pF,5%,50V,NPO,TP,1608,		Q201	0501-000218	TR-SMALL SIGNAL:2SC4081.NPN,200mW,UMT,TP	
C314	2203-001618	C-CERAMIC,CHIP:27pF,5%,50V,CH,1608,1.6mm		Q206	0506-000150	TR-ARRAY:UMX2N,NPN,2,50V,40V,100MA,300M	

Loc.No	Part No	Desc & Spec	Remark	Loc.No	Part No	Desc & Spec	Remark
Q207	0506-000151	TR-ARRAY:UMZ1N,NPN/PNP,1,50V,40V,100MA,		R202	2007-000077	R-CHIP:470ohm,5%,1/16W,DA,TP,1608	
Q208	0501-000218	TR-SMALL SIGNAL:2SC4081,NPN,200mW,UMT,TP		R203	2007-000683	R-CHIP:3.3Kohm,1%,1/16W,DA,TP,1608	
Q209	0501-000218	TR-SMALL SIGNAL:2SC4081,NPN,200mW,UMT,TP		R204	2007-000121	R-CHIP:820ohm,5%,1/16W,DA,TP,1608	
Q210	0504-000107	TR-DIGITAL:DTA144EU,PNP,200mW,47K-47K,SC		R205	2007-000124	R-CHIP:2.2Kohm,5%,1/16W,DA,TP,1608	
Q211	0501-000218	TR-SMALL SIGNAL:2SC4081,NPN,200mW,UMT,TP		R206	2007-000121	R-CHIP:820ohm,5%,1/16W,DA,TP,1608	
Q212	0506-000151	TR-ARRAY:UMZ1N,NPN/PNP,1,50V,40V,100MA,		R208	2007-000123	R-CHIP:1.5Kohm,5%,1/16W,DA,TP,1608	
Q213	0501-000162	TR-SMALL SIGNAL:2SA1576,PNP,200mW,SC-70,		R209	2007-000091	R-CHIP:12Kohm,5%,1/16W,DA,TP,1608	
Q214	0501-000218	TR-SMALL SIGNAL:2SC4081,NPN,200mW,UMT,TP		R210	2007-001179	R-CHIP:8.2Kohm,5%,1/16W,DA,TP,1608	
Q215	0506-000150	TR-ARRAY:UMX2N,NPN,2,50V,40V,100MA,300M		R213	2007-000090	R-CHIP:10Kohm,5%,1/16W,DA,TP,1608	
Q216	0504-000110	TR-DIGITAL:DTC114EU,NPN,200mW,10K-10Kohm		R214	2007-000839	R-CHIP:39ohm,5%,1/16W,DA,TP,1608	
Q218	0501-000218	TR-SMALL SIGNAL:2SC4081,NPN,200mW,UMT,TP		R215	2007-000113	R-CHIP:33ohm,5%,1/16W,DA,TP,1608	
Q219	0501-000162	TR-SMALL SIGNAL:2SA1576,PNP,200mW,SC-70,		R216	2007-000043	R-CHIP:1Kohm,1%,1/16W,DA,TP,1608	
Q220	0504-000177	TR-DIGITAL:DTC143EU,NPN,200mW,4.7K-4.7K		R217	2007-000043	R-CHIP:1Kohm,1%,1/16W,DA,TP,1608	
Q221	0504-000113	TR-DIGITAL:DTC144EU,NPN,200mW,47K-47K,S		R220	2007-000130	R-CHIP:39Kohm,5%,1/16W,DA,TP,1608	
Q222	0504-000177	TR-DIGITAL:DTC143EU,NPN,200mW,4.7K-4.7K		R221	2007-000100	R-CHIP:68Kohm,5%,1/16W,DA,TP,1608	
Q223	0504-000105	TR-DIGITAL:DTA114EU,PNP,200mW,10K-10K,SC		R222	2007-000125	R-CHIP:3.9Kohm,5%,1/16W,DA,TP,1608	
Q231	0501-000162	TR-SMALL SIGNAL:2SA1576,PNP,200mW,SC-70,		R223	2007-000078	R-CHIP:1Kohm,5%,1/16W,DA,TP,1608	
Q301	0506-000150	TR-ARRAY:UMX2N,NPN,2,50V,40V,100MA,300M		R224	2007-000086	R-CHIP:5.6Kohm,5%,1/16W,DA,TP,1608	
Q302	0506-000150	TR-ARRAY:UMX2N,NPN,2,50V,40V,100MA,300M		R225	2007-000458	R-CHIP:18Kohm,5%,1/16W,DA,TP,1608	
Q303	0501-000218	TR-SMALL SIGNAL:2SC4081,NPN,200mW,UMT,TP		R226	2007-001179	R-CHIP:8.2Kohm,5%,1/16W,DA,TP,1608	
Q304	0504-000107	TR-DIGITAL:DTA144EU,PNP,200mW,47K-47K,SC		R227	2007-000458	R-CHIP:18Kohm,5%,1/16W,DA,TP,1608	
Q305	0506-000150	TR-ARRAY:UMX2N,NPN,2,50V,40V,100MA,300M		R228	2007-000078	R-CHIP:1Kohm,5%,1/16W,DA,TP,1608	
Q306	0501-000162	TR-SMALL SIGNAL:2SA1576,PNP,200mW,SC-70,		R231	2007-000125	R-CHIP:3.9Kohm,5%,1/16W,DA,TP,1608	
Q350	0501-000218	TR-SMALL SIGNAL:2SC4081,NPN,200mW,UMT,TP		R232	2007-000124	R-CHIP:2.2Kohm,5%,1/16W,DA,TP,1608	
Q351	0506-000146	TR-ARRAY:UMH6N,NPN,2,150MW,UM6,TP,68		R233	2007-000090	R-CHIP:10Kohm,5%,1/16W,DA,TP,1608	
Q352	0506-000146	TR-ARRAY:UMH6N,NPN,2,150MW,UM6,TP,68		R234	2007-000078	R-CHIP:1Kohm,5%,1/16W,DA,TP,1608	
Q353	0504-000107	TR-DIGITAL:DTA144EU,PNP,200mW,47K-47K,SC		R236	2007-000109	R-CHIP:1Mohm,5%,1/16W,DA,TP,1608	
Q354	0501-000218	TR-SMALL SIGNAL:2SC4081,NPN,200mW,UMT,TP		R237	2007-000094	R-CHIP:22Kohm,5%,1/16W,DA,TP,1608	
Q355	0504-000107	TR-DIGITAL:DTA144EU,PNP,200mW,47K-47K,SC		R238	2007-000076	R-CHIP:330ohm,5%,1/16W,DA,TP,1608	
Q381	0501-000162	TR-SMALL SIGNAL:2SA1576,PNP,200mW,SC-70,		R239	2007-000077	R-CHIP:470ohm,5%,1/16W,DA,TP,1608	
Q382	0504-000113	TR-DIGITAL:DTC144EU,NPN,200mW,47K-47K,S		R240	2007-000074	R-CHIP:100ohm,5%,1/16W,DA,TP,1608	
R000	2007-000070	R-CHIP:0ohm,5%,1/16W,DA,TP,1608		R243	2007-000119	R-CHIP:560ohm,5%,1/16W,DA,TP,1608	
R103	2007-000099	R-CHIP:62Kohm,5%,1/16W,DA,TP,1608		R244	2007-000120	R-CHIP:680ohm,5%,1/16W,DA,TP,1608	
R104	2007-000123	R-CHIP:1.5Kohm,5%,1/16W,DA,TP,1608		R246	2007-000090	R-CHIP:10Kohm,5%,1/16W,DA,TP,1608	
R105	2007-000082	R-CHIP:3.3Kohm,5%,1/16W,DA,TP,1608		R247	2007-000119	R-CHIP:560ohm,5%,1/16W,DA,TP,1608	
R106	2007-000119	R-CHIP:560ohm,5%,1/16W,DA,TP,1608		R248	2007-000119	R-CHIP:560ohm,5%,1/16W,DA,TP,1608	
R107	2007-001179	R-CHIP:8.2Kohm,5%,1/16W,DA,TP,1608		R249	2007-000078	R-CHIP:1Kohm,5%,1/16W,DA,TP,1608	
R108	2007-001179	R-CHIP:8.2Kohm,5%,1/16W,DA,TP,1608		R250	2007-000078	R-CHIP:1Kohm,5%,1/16W,DA,TP,1608	
R110	2007-000070	R-CHIP:0ohm,5%,1/16W,DA,TP,1608		R251	2007-000120	R-CHIP:680ohm,5%,1/16W,DA,TP,1608	
R112	2007-000450	R-CHIP:180ohm,5%,1/16W,DA,TP,1608		R252	2007-000078	R-CHIP:1Kohm,5%,1/16W,DA,TP,1608	
R113	2007-000076	R-CHIP:330ohm,5%,1/16W,DA,TP,1608		R253	2007-000123	R-CHIP:1.5Kohm,5%,1/16W,DA,TP,1608	
R114	2007-000076	R-CHIP:330ohm,5%,1/16W,DA,TP,1608		R254	2007-000078	R-CHIP:1Kohm,5%,1/16W,DA,TP,1608	
R115	2007-000450	R-CHIP:180ohm,5%,1/16W,DA,TP,1608		R255	2007-000078	R-CHIP:1Kohm,5%,1/16W,DA,TP,1608	
R117	2007-000071	R-CHIP:22ohm,5%,1/16W,DA,TP,1608		R256	2007-001179	R-CHIP:8.2Kohm,5%,1/16W,DA,TP,1608	
R118	2007-000643	R-CHIP:270ohm,5%,1/16W,DA,TP,1608		R257	2007-000090	R-CHIP:10Kohm,5%,1/16W,DA,TP,1608	
R119	2007-000075	R-CHIP:220ohm,5%,1/16W,DA,TP,1608		R258	2007-000458	R-CHIP:18Kohm,5%,1/16W,DA,TP,1608	
R120	2007-000094	R-CHIP:22Kohm,5%,1/16W,DA,TP,1608		R259	2007-000093	R-CHIP:20Kohm,5%,1/16W,DA,TP,1608	
R121	2007-000134	R-CHIP:33Kohm,5%,1/16W,DA,TP,1608		R261	2007-000078	R-CHIP:1Kohm,5%,1/16W,DA,TP,1608	
R122	2007-000082	R-CHIP:3.3Kohm,5%,1/16W,DA,TP,1608		R262	2007-000090	R-CHIP:10Kohm,5%,1/16W,DA,TP,1608	
R131	2007-000092	R-CHIP:15Kohm,5%,1/16W,DA,TP,1608		R263	2007-000078	R-CHIP:1Kohm,5%,1/16W,DA,TP,1608	
R132	2007-001179	R-CHIP:8.2Kohm,5%,1/16W,DA,TP,1608		R264	2007-000078	R-CHIP:1Kohm,5%,1/16W,DA,TP,1608	
R151	2007-000134	R-CHIP:33Kohm,5%,1/16W,DA,TP,1608		R265	2007-000123	R-CHIP:1.5Kohm,5%,1/16W,DA,TP,1608	
R152	2007-000092	R-CHIP:15Kohm,5%,1/16W,DA,TP,1608		R267	2007-000078	R-CHIP:1Kohm,5%,1/16W,DA,TP,1608	
R153	2007-000078	R-CHIP:1Kohm,5%,1/16W,DA,TP,1608		R268	2007-000124	R-CHIP:2.2Kohm,5%,1/16W,DA,TP,1608	
R154	2007-000077	R-CHIP:470ohm,5%,1/16W,DA,TP,1608		R269	2007-000120	R-CHIP:680ohm,5%,1/16W,DA,TP,1608	
R155	2007-000077	R-CHIP:470ohm,5%,1/16W,DA,TP,1608		R270	2007-000120	R-CHIP:680ohm,5%,1/16W,DA,TP,1608	
R156	2007-000078	R-CHIP:1Kohm,5%,1/16W,DA,TP,1608		R271	2007-000118	R-CHIP:390ohm,5%,1/16W,DA,TP,1608	
R159	2007-000076	R-CHIP:330ohm,5%,1/16W,DA,TP,1608		R272	2007-000090	R-CHIP:10Kohm,5%,1/16W,DA,TP,1608	
R160	2007-000124	R-CHIP:2.2Kohm,5%,1/16W,DA,TP,1608		R273	2007-000078	R-CHIP:1Kohm,5%,1/16W,DA,TP,1608	
R162	2007-000078	R-CHIP:1Kohm,5%,1/16W,DA,TP,1608		R274	2007-000120	R-CHIP:680ohm,5%,1/16W,DA,TP,1608	
R163	2007-000124	R-CHIP:2.2Kohm,5%,1/16W,DA,TP,1608		R275	2007-000078	R-CHIP:1Kohm,5%,1/16W,DA,TP,1608	
R165	2007-000458	R-CHIP:18Kohm,5%,1/16W,DA,TP,1608		R276	2007-000078	R-CHIP:1Kohm,5%,1/16W,DA,TP,1608	
R166	2007-000123	R-CHIP:1.5Kohm,5%,1/16W,DA,TP,1608		R277	2007-000094	R-CHIP:22Kohm,5%,1/16W,DA,TP,1608	
R167	2007-000077	R-CHIP:470ohm,5%,1/16W,DA,TP,1608		R278	2007-000092	R-CHIP:15Kohm,5%,1/16W,DA,TP,1608	
R168	2007-000119	R-CHIP:560ohm,5%,1/16W,DA,TP,1608		R279	2007-000123	R-CHIP:1.5Kohm,5%,1/16W,DA,TP,1608	
R169	2007-000079	R-CHIP:1.8Kohm,5%,1/16W,DA,TP,1608		R280	2007-000121	R-CHIP:820ohm,5%,1/16W,DA,TP,1608	
R171	2007-000458	R-CHIP:18Kohm,5%,1/16W,DA,TP,1608		R281	2007-000121	R-CHIP:820ohm,5%,1/16W,DA,TP,1608	
R172	2007-000078	R-CHIP:1Kohm,5%,1/16W,DA,TP,1608		R282	2007-000086	R-CHIP:5.6Kohm,5%,1/16W,DA,TP,1608	
R173	2007-000079	R-CHIP:1.8Kohm,5%,1/16W,DA,TP,1608		R283	2007-000079	R-CHIP:1.8Kohm,5%,1/16W,DA,TP,1608	
R174	2007-000078	R-CHIP:1Kohm,5%,1/16W,DA,TP,1608		R284	2007-000119	R-CHIP:560ohm,5%,1/16W,DA,TP,1608	
R177	2007-000122	R-CHIP:1.2Kohm,5%,1/16W,DA,TP,1608		R285	2007-000078	R-CHIP:1Kohm,5%,1/16W,DA,TP,1608	
R178	2007-000122	R-CHIP:1.2Kohm,5%,1/16W,DA,TP,1608		R286	2007-000078	R-CHIP:1Kohm,5%,1/16W,DA,TP,1608	
R201	2007-000219	R-CHIP:1.2Kohm,1%,1/16W,DA,TP,1608		R287	2007-000078	R-CHIP:1Kohm,5%,1/16W,DA,TP,1608	

Electrical Parts List

Loc.No	Part No	Desc & Spec	Remark	Loc.No	Part No	Desc & Spec	Remark
R288	2007-000078	R-CHIP:1Kohm,5%,1/16W,DA,TP,1608		C52	2203-001537	C-CERAMIC,CHIP;1nF,10%,50V,X7R,TP,2012,-	
R292	2007-000124	R-CHIP:2.2Kohm,5%,1/16W,DA,TP,1608		C53	2401-001878	C-AL:1000UF,20%,16V,GP,BK,10X20MM,5	
R295	2007-000125	R-CHIP:3.9Kohm,5%,1/16W,DA,TP,1608		C54	2401-001374	C-AL:470UF,20%,16V,WT,TP,10X12.5,2	
R302	2007-001026	R-CHIP:560Kohm,5%,1/16W,DA,TP,1608		C55	2203-000199	C-CERAMIC,CHIP:100nF,+80-20%,50V,Z5U,TP,	
R303	2007-000120	R-CHIP:680ohm,5%,1/16W,DA,TP,1608		C56	2203-000260	C-CERAMIC,CHIP;10nF,10%,50V,X7R,TP,2012,	
R304	2007-000512	R-CHIP:2.4Kohm,5%,1/16W,DA,TP,1608		C57	2401-001917	C-AL:1UF,20%,50V,-,TP,5X7MM,5	
R305	2007-000077	R-CHIP:470ohm,5%,1/16W,DA,TP,1608		C59	2401-001952	C-AL:4.7UF,20%,50V,-,TP,6.3X7.5	
R306	2007-001134	R-CHIP:68ohm,5%,1/16W,DA,TP,1608		C60	61453-131-105	C-CERAMIC,CHIP:GRM42-6Y5V105Z16 TAPG	
R307	2007-000643	R-CHIP:270ohm,5%,1/16W,DA,TP,1608		C61	2203-000199	C-CERAMIC,CHIP;100nF,+80-20%,50V,Z5U,TP,	
R308	2007-000120	R-CHIP:680ohm,5%,1/16W,DA,TP,1608		C62	B1100-0674	C-CERAMIC,CHIP:CK 73 Y5V 16V T 685-Z C32	
R309	2007-000075	R-CHIP:220ohm,5%,1/16W,DA,TP,1608		C64	2201-000913	C-CERAMIC,DISC;100NF,+80-20%,50V,Y5V,TP,	
R310	2007-000078	R-CHIP:1Kohm,5%,1/16W,DA,TP,1608		C65	2202-000780	C-CERAMIC,MISC-AXIAL:100NF,+80-20%,50V,Y5	
R311	2007-000122	R-CHIP:1.2Kohm,5%,1/16W,DA,TP,1608		C66	2203-000199	C-CERAMIC,CHIP;100nF,+80-20%,50V,Z5U,TP,	
R312	2007-000119	R-CHIP:560ohm,5%,1/16W,DA,TP,1608		C67	2203-000199	C-CERAMIC,CHIP:100nF,+80-20%,50V,Z5U,TP,	
R313	2007-000079	R-CHIP:1.8Kohm,5%,1/16W,DA,TP,1608		CL10	64709-084-770	CLIP-FUSE:RBP4-1 1/2H 3A 0.4T	
R314	2007-000839	R-CHIP:39ohm,5%,1/16W,DA,TP,1608		CL11	64709-084-770	CLIP-FUSE:RBP4-1 1/2H 3A 0.4T	
R315	2007-000119	R-CHIP:560ohm,5%,1/16W,DA,TP,1608		D10	0402-000386	DIODE-BRIDGE:S1WB60,600V,1A,DIP-4	
R316	2007-000084	R-CHIP:4.7Kohm,5%,1/16W,DA,TP,1608		D11	0402-000391	DIODE-RECTIFIER:ERA22-10,1000V,500MA,MSR	
R317	2007-000078	R-CHIP:1Kohm,5%,1/16W,DA,TP,1608		D12	0401-000171	DIODE-SWITCHING:MA111,80V,100mA,-,3nS,SM	
R319	2007-000121	R-CHIP:820ohm,5%,1/16W,DA,TP,1608		D13	0403-000646	DIODE-ZENER:RD205B,20V,18.8-21.14V,200mW	
R320	2007-000078	R-CHIP:1Kohm,5%,1/16W,DA,TP,1608		D14	0403-000648	DIODE-ZENER:RD4.7SB,4.7V,4.4-4.92,200mW,	
R321	2007-000078	R-CHIP:1Kohm,5%,1/16W,DA,TP,1608		D15	0403-000647	DIODE-ZENER:RD245B,24V,22.86-25.66V,200m	
R322	2007-000078	R-CHIP:1Kohm,5%,1/16W,DA,TP,1608		D16	0402-000391	DIODE-RECTIFIER:ERA22-10,1000V,500MA,MSR	
R326	2007-000070	R-CHIP:0ohm,5%,1/16W,DA,TP,1608		D17	0402-000391	DIODE-RECTIFIER:ERA22-10,1000V,500MA,MSR	
R329	2007-000101	R-CHIP:82Kohm,5%,1/16W,DA,TP,1608		D51	0404-000135	DIODE-SCHOTTKY:ESAC85M-009,90V,10A,TO-22	
R330	2007-000116	R-CHIP:120ohm,5%,1/16W,DA,TP,1608		D52	0402-000165	DIODE-RECTIFIER:1N5819,40V,1A,DO-41,TP	
R331	2007-000090	R-CHIP:10Kohm,5%,1/16W,DA,TP,1608		D53	0407-000114	DIODE-ARRAY:DAN202K,80V,100mA,CA2-3,SOT-	
R332	2007-000078	R-CHIP:1Kohm,5%,1/16W,DA,TP,1608		D54	0407-000116	DIODE-ARRAY:DAP202K,80V,100mA,CK2-3,SOT	
R335	2007-000077	R-CHIP:470ohm,5%,1/16W,DA,TP,1608		D55	0401-000171	DIODE-SWITCHING:MA111,80V,100mA,-,3nS,SM	
R336	2007-000071	R-CHIP:22ohm,5%,1/16W,DA,TP,1608		D57	0403-000649	DIODE-ZENER:RDS.1S,5.1V,4.96-5.22V,200mW	
R350	2007-000124	R-CHIP:2.2Kohm,5%,1/16W,DA,TP,1608		F10	B3065-0202	FUSE:DEMKO FST 250V 1.25A 5X20MM S505 C	
R351	2007-000084	R-CHIP:4.7Kohm,5%,1/16W,DA,TP,1608		IC11	AC14-12011C	IC:FA5304S,SOP8P TAPE	
R352	2007-000124	R-CHIP:2.2Kohm,5%,1/16W,DA,TP,1608		IC12	AC13-22001B	IC-HYBRID:PC113(LY),-DIP-	
R353	2007-000082	R-CHIP:3.3Kohm,5%,1/16W,DA,TP,1608		IC12	B4161-0037	PHOTO-COUPLER:TLP621-GR ST	
R354	2007-000090	R-CHIP:10Kohm,5%,1/16W,DA,TP,1608		IC51	1201-000203	IC-OP AMP:3414,SOP8P,300MIL,DUAL,-,PLAS	
R355	2007-000097	R-CHIP:47Kohm,5%,1/16W,DA,TP,1608		IC52	AC14-12006R	IC:TK116400,TO-92S,3P TAPE	
R356	2007-000124	R-CHIP:2.2Kohm,5%,1/16W,DA,TP,1608		J51	B3040-0068	JACK-DC:PI3 HEC0740-01-010 3P	
R357	2007-000102	R-CHIP:100Kohm,5%,1/16W,DA,TP,1608		L10	AC27-32001F	COIL-LINE FILTER:BSF-2123,20MH,20HM,ST,-	
R358	2007-000102	R-CHIP:100Kohm,5%,1/16W,DA,TP,1608		L11	A1247-0053	FILTER-EMI BEAD:BSF3565A0L SB 1000HM/100	
R359	2007-000094	R-CHIP:22Kohm,5%,1/16W,DA,TP,1608		L51	2702-000112	INDUCTOR-RADIAL:10uH,5%,6x6.4mm	
R360	2007-000090	R-CHIP:10Kohm,5%,1/16W,DA,TP,1608		L52	AC27-12001F	COIL-CHOKER:100UH,J,-,100UH-J RA 1KHZ	
R361	2007-000102	R-CHIP:100Kohm,5%,1/16W,DA,TP,1608		LED51	B4150-0287	LED-DISPLAY:LN086WP38 ORG/GRN P11.8	
R362	2007-000097	R-CHIP:47Kohm,5%,1/16W,DA,TP,1608		PCB01	66029-1084-00	P.C.B-AA-E2N:FR4 CS95 T1.6 W139 L62	
R364	2007-000121	R-CHIP:820ohm,5%,1/16W,DA,TP,1608		PWR01	AC39-12022M	POWER-CORD:K2,KJ-0201,BLK,YH396-32V,1.8	
R366	2007-000090	R-CHIP:10Kohm,5%,1/16W,DA,TP,1608		Q10	0505-001044	FET-SILICON:SSS3N80,N,800V,1.8A,5ohm,35W	
R367	2007-000091	R-CHIP:12Kohm,5%,1/16W,DA,TP,1608		Q51	0502-000399	TR-POWER:2SB1127S,PNP,-25V,-20V,5A,1W,	
R368	2007-000078	R-CHIP:1Kohm,5%,1/16W,DA,TP,1608		Q52	62129-101-110	TRANSISTOR.CHIP:KSR 1102 (REEL)	
R369	2007-000078	R-CHIP:1Kohm,5%,1/16W,DA,TP,1608		Q53	0502-000431	TR-POWER:2SB1203S,PNP,-60V,-50V,5A,1W,	
R371	2007-000097	R-CHIP:47Kohm,5%,1/16W,DA,TP,1608		Q54	62129-101-110	TRANSISTOR.CHIP:KSR 1102 (REEL)	
R381	2007-000084	R-CHIP:4.7Kohm,5%,1/16W,DA,TP,1608		Q55	0504-000158	TR-DIGITAL:KSR2104,PNP,200MW,47K-47K,SOT	
R382	2007-000078	R-CHIP:1Kohm,5%,1/16W,DA,TP,1608		Q56	0504-000158	TR-DIGITAL:KSR2104,PNP,200MW,47K-47K,SOT	
R396	2007-000458	R-CHIP:18Kohm,5%,1/16W,DA,TP,1608		Q57	0504-000158	TR-DIGITAL:KSR2104,PNP,200MW,47K-47K,SOT	
X201	2801-003240	CRYSTAL-SMD:4.433619MHz,20ppm,28-ABN,SER		R01	2007-000029	R-CHIP:0ohm,5%,1/10W,DA,TP,2012	
				R02	2007-000029	R-CHIP:0ohm,5%,1/10W,DA,TP,2012	
				R03	2007-000029	R-CHIP:0ohm,5%,1/10W,DA,TP,2012	
				R04	2007-000029	R-CHIP:0ohm,5%,1/10W,DA,TP,2012	
				R05	2007-000033	R-CHIP:0ohm,5%,1/8W,DA,TP,3216	
				R06	2007-000033	R-CHIP:0ohm,5%,1/8W,DA,TP,3216	
C10	AD44-30100H	ADAPTER-AC POWER:110-220V,60HZ,AA-E4/SEU		R10	2001-000474	R-CARBON:2.7Mohm,5%,1/4W,AA,TP,2.4x6.4mm	
C11	2306-000298	C-FILM,MPPF:220nF,20%,250V,TP,6.5x5.5x3mm		R12	A1014-0079	R-CEMENT:RWC 2W 1 3R3-J ST ABCO	
C12	2201-000808	C-CERAMIC,DISC:2.2nF,10%,400V,Y5P,12x7.5		R13	2001-001000	R-CARBON:82Kohm,5%,1/8W,AA,TP,1.8x3.2mm	
C13	2401-001567	C-AL:47uF,20%,400V,WT,-,18x20,10mm		R14	2001-001000	R-CARBON:82Kohm,5%,1/8W,AA,TP,1.8x3.2mm	
C14	2201-000808	C-CERAMIC,DISC:2.2nF,10%,400V,Y5P,12x7.5		R15	2007-001212	R-CHIP:820ohm,5%,1/8W,DA,TP,3216	
C15	2201-000808	C-CERAMIC,DISC:2.2nF,10%,400V,Y5P,12x7.5		R16	2001-001000	R-CARBON:82Kohm,5%,1/8W,AA,TP,1.8x3.2mm	
C16	2301-000140	C-FILM,PEF:10nF,10%,630V,16.5X9.5X5.7X,1		R17	2003-000307	R-METAL OXIDE:47Kohm,5%,2W,AD,TP,6x16mm	
C17	2203-001537	C-CERAMIC,CHIP:1nF,10%,50V,X7R,TP,2012,-		R19	2003-000111	R-METAL OXIDE:0.47ohm,5%,1W,AD,TP,4.3x12	
C18	2401-002180	C-AL:2.2UF,20%,50V,GP,TP,5X11,5MM		R20	2007-000572	R-CHIP:220ohm,5%,1/10W,DA,TP,2012	
C19	2203-000840	C-CERAMIC,CHIP:390PF,5%,50V,NPO,TP,2012,		R21	2007-000781	R-CHIP:33ohm,5%,1/10W,DA,TP,2012	
C20	2203-001576	C-CERAMIC,CHIP:150NF,+80-20%,50V,Z5U,TP,		R22	2007-000248	R-CHIP:1.5Mohm,5%,1/10W,DA,TP,2012	
C21	2401-001184	C-AL:33UF,20%,35V,GP,-,6X11,5MM		R24	2007-000781	R-CHIP:33ohm,5%,1/10W,DA,TP,2012	
C22	2401-002168	C-AL:100UF,20%,50V,GP,TP,10X12.5,5M		R25	2007-001177	R-CHIP:8.2Kohm,5%,1/10W,DA,TP,2012	
C23	2203-000199	C-CERAMIC,CHIP:100nF,+80-20%,50V,Z5U,TP,		R51	2007-000312	R-CHIP:10ohm,5%,1/8W,DA,TP,3216	
C50	2401-001591	C-AL:47uF,20%,6.3V,GP,5x7,2.5mm,		R52	2007-000515	R-CHIP:2.7Kohm,1%,1/10W,DA,TP,2012	
C51	2203-001537	C-CERAMIC,CHIP:1nF,10%,50V,X7R,TP,2012,-					



Electrical Parts List

Loc.No	Part No	Desc & Spec	Remark	Loc.No	Part No	Desc & Spec	Remark
RE02	2007-000113	R-CHIP:33ohm,5%,1/16W,DA,TP,1608		CE52	2203-001588	C-CERAMIC,CHIP;18pF,5%,50V,CH,1608,1.6mm	
RE03	2007-000084	R-CHIP:4.7Kohm,5%,1/16W,DA,TP,1608		CNE01	3708-001143	CONNECTOR-FPC/FPC/PIC;12P,0.8mm,SMD-A,SN	
RE04	2007-000107	R-CHIP:470Kohm,5%,1/16W,DA,TP,1608		CNE02	3708-000514	CONNECTOR-FPC/FPC/PIC;16P,0.5MM,SMD-S,SN	
RE05	2007-000102	R-CHIP:100Kohm,5%,1/16W,DA,TP,1608		CNE03	3711-002613	CONNECTOR-HEADER:3WALL,3P,1R,1.25MM,SMD-	
RE06	2007-000097	R-CHIP:47Kohm,5%,1/16W,DA,TP,1608		DE01	0405-000123	DIODE-VARACTOR:1T369,34V,10nA,DSM,TP	
RE07	2007-000637	R-CHIP:270Kohm,5%,1/16W,DA,TP,1608		DE02	0401-000171	DIODE-SWITCHING:MA111,80V,100mA,-,3nS,SM	
RE08	2007-000074	R-CHIP:100ohm,5%,1/16W,DA,TP,1608		DE03	0401-000171	DIODE-SWITCHING:MA111,80V,100mA,-,3nS,SM	
RE09	2007-000695	R-CHIP:3.3ohm,5%,1/16W,DA,TP,1608		DE04	0401-000171	DIODE-SWITCHING:MA111,80V,100mA,-,3nS,SM	
RE10	2007-000079	R-CHIP:1.8Kohm,5%,1/16W,DA,TP,1608		ICE01	1003-001104	IC-LCD DRIVER:CXA2503R,QFP,64P,400MIL,TR	
RE11	B1335-0002	THERMISTOR-CHIP:NTC CS 3216 3BH 471KC 47		ICE02	AC11-12001G	IC-EEPROM:AT24C02N-10SC,QFP,-	
RE12	2007-000931	R-CHIP:470ohm,5%,1/10W,DA,TP,2012		ICE03	AD14-10001C	IC-AMP;NJM2904V,SSOP,OP-AMP	
RE13	2007-000078	R-CHIP:1Kohm,5%,1/16W,DA,TP,1608		ICE04	0801-000301	IC-CMOS LOGIC;7W04,INVERTER,SOP8P,150MI	
RE14	2007-000081	R-CHIP:2.7Kohm,5%,1/16W,DA,TP,1608		ICE05	0801-000301	IC-CMOS LOGIC;7W04,INVERTER,SOP8P,150MI	
RE15	2007-000965	R-CHIP:5.1Kohm,5%,1/16W,DA,TP,1608		ICE06	0801-002001	IC-CMOS LOGIC;7W74,D FLIP FLOP,SOP8P,12	
RE16	2007-000078	R-CHIP:1Kohm,5%,1/16W,DA,TP,1608		LE03	2703-001493	INDUCTOR-SMD;10uH,5%,2.5x2.0x1.8	
RE17	2007-001056	R-CHIP:6.2Kohm,5%,1/16W,DA,TP,1608		LE04	2703-000403	INDUCTOR-SMD;22uH,10%,3.2x2.5x2.2mm	
RE18	2007-000101	R-CHIP:82Kohm,5%,1/16W,DA,TP,1608		LE05	2703-000403	INDUCTOR-SMD;22uH,10%,3.2x2.5x2.2mm	
RE19	2007-001179	R-CHIP:8.2Kohm,5%,1/16W,DA,TP,1608		LE06	2703-000398	INDUCTOR-SMD;10UH,10%,3.2x2.5x2.2MM	
RE20	2007-000130	R-CHIP:39Kohm,5%,1/16W,DA,TP,1608		LE07	2703-000403	INDUCTOR-SMD;22uH,10%,3.2x2.5x2.2mm	
RE21	2007-000070	R-CHIP:0ohm,5%,1/10W,DA,TP,1608		QE01	0501-000218	TR-SMALL SIGNAL:2SC4081,NPN,200mW,UMT,TP	
RE22	2007-000082	R-CHIP:3.3Kohm,5%,1/16W,DA,TP,1608		QE02	0506-000138	TR-ARRAY;IMZ1,NPN/PNP,1.50V,40V,100MA,3	
RE23	2007-000029	R-CHIP:0ohm,5%,1/10W,DA,TP,2012		QE03	0504-000211	TR-DIGITAL-DTC143TU,NPN,200MW,4.7K,SC-70	
RE24	2007-000029	R-CHIP:0ohm,5%,1/10W,DA,TP,2012		QE04	0504-000211	TR-DIGITAL-DTC143TU,NPN,200MW,4.7K,SC-70	
RE25	2007-000689	R-CHIP:3.3MOHM,5%,1/10W,DA,TP,2012		QE05	0504-000211	TR-DIGITAL-DTC143TU,NPN,200MW,4.7K,SC-70	
RE26	2007-000689	R-CHIP:3.3MOHM,5%,1/10W,DA,TP,2012		QE06	0504-000211	TR-DIGITAL-DTC143TU,NPN,200MW,4.7K,SC-70	
RE27	2007-000462	R-CHIP:18ohm,5%,1/10W,DA,TP,2012		QE07	0504-000211	TR-DIGITAL-DTC143TU,NPN,200MW,4.7K,SC-70	
VRE01	2104-001014	VR-SMD:50KOHM,25%,0.15W,TOP		QE08	0501-000218	TR-SMALL SIGNAL:2SC4081,NPN,200mW,UMT,TP	
VRE02	2104-001013	VR-SMD:22ohm,25%,0.15W,TOP		RE01	2007-000097	R-CHIP:47Kohm,5%,1/16W,DA,TP,1608	
VRE03	2104-000178	VR-SMD:1MOHM,30%,1/20W,TOP		RE02	2007-000092	R-CHIP:15Kohm,5%,1/16W,DA,TP,1608	
				RE03	2007-000097	R-CHIP:47Kohm,5%,1/16W,DA,TP,1608	
				RE04	2007-000130	R-CHIP:39Kohm,5%,1/16W,DA,TP,1608	
				RE07	2007-000091	R-CHIP:12Kohm,5%,1/16W,DA,TP,1608	
				RE08	2007-000637	R-CHIP:270Kohm,5%,1/16W,DA,TP,1608	
				RE09	2007-000106	R-CHIP:220Kohm,5%,1/16W,DA,TP,1608	
				RE10	2007-000094	R-CHIP:22Kohm,5%,1/16W,DA,TP,1608	
				RE11	2007-000094	R-CHIP:22Kohm,5%,1/16W,DA,TP,1608	
				RE12	2007-000655	R-CHIP:27Kohm,5%,1/16W,DA,TP 200	
				RE13	2007-000124	R-CHIP:2.2Kohm,5%,1/16W,DA,TP,1608	
				RE14	2007-000090	R-CHIP:10Kohm,5%,1/16W,DA,TP,1608	
				RE16	2007-001157	R-CHIP:750ohm,5%,1/16W,DA,TP,160	
				RE17	2007-000070	R-CHIP:0ohm,5%,1/16W,DA,TP,1608	
				RE18	2007-000078	R-CHIP:1Kohm,5%,1/16W,DA,TP,1608	
				RE19	2007-000134	R-CHIP:33Kohm,5%,1/16W,DA,TP,1608	
				RE20	2007-000090	R-CHIP:10Kohm,5%,1/16W,DA,TP,1608	
				RE21	2007-000090	R-CHIP:10Kohm,5%,1/16W,DA,TP,1608	
				RE22	2007-000614	R-CHIP:24Kohm,1%,1/16W,DA,TP,1608	
				RE23	2007-000239	R-CHIP:1.5Kohm,1%,1/16W,DA,TP,1608	
				RE24	2007-000084	R-CHIP:4.7Kohm,5%,1/16W,DA,TP,1608	
				RE25	2007-000455	R-CHIP:18Kohm,1%,1/16W,DA,TP,1608	
				RE26	2007-000614	R-CHIP:24Kohm,1%,1/16W,DA,TP,1608	
				RE27	2007-000683	R-CHIP:3.3Kohm,1%,1/16W,DA,TP,1608	
				RE28	2007-000067	R-CHIP:15Kohm,1%,1/16W,DA,TP,1608	
				RE29	2007-000078	R-CHIP:1Kohm,5%,1/16W,DA,TP,1608	
				RE30	2007-000124	R-CHIP:2.2Kohm,5%,1/16W,DA,TP,1608	
				RE31	2007-000124	R-CHIP:2.2Kohm,5%,1/16W,DA,TP,1608	
				RE32	2007-000090	R-CHIP:10Kohm,5%,1/16W,DA,TP,1608	
				RE34	2007-000078	R-CHIP:1Kohm,5%,1/16W,DA,TP,1608	
				RE40	2007-000102	R-CHIP:100Kohm,5%,1/16W,DA,TP,1608	
				RE44	2007-001442	R-CHIP:10ohm,5%,1/16W,DA,TP,1608	
				RE45	2007-000075	R-CHIP:220ohm,5%,1/16W,DA,TP,1608	
				RE47	2007-000075	R-CHIP:220ohm,5%,1/16W,DA,TP,1608	
				RE51	2007-000123	R-CHIP:1.5Kohm,5%,1/16W,DA,TP,1608	
				RE55	2007-000078	R-CHIP:1Kohm,5%,1/16W,DA,TP,1608	
				RE56	2007-000086	R-CHIP:5.6Kohm,5%,1/16W,DA,TP,1608	
				RE57	2007-000079	R-CHIP:1.8Kohm,5%,1/16W,DA,TP,1608	
				RE58	2007-000087	R-CHIP:6.8Kohm,5%,1/16W,DA,TP,1608	
				RE61	2007-000070	R-CHIP:0ohm,5%,1/16W,DA,TP,1608	
				RE62	2007-000070	R-CHIP:0ohm,5%,1/16W,DA,TP,1608	
				RE63	2007-000070	R-CHIP:0ohm,5%,1/16W,DA,TP,1608	
				XE01	2801-003126	CRYSTAL-SMD:4.433619MHz,30ppm,28-ABN,16p	
<b>613</b>	<b>AD90-10828V</b>	<b>ASSY-CVF BOARD;VP-A20,A2-CVF-PAL</b>	<b>VP-A21/A23</b>				
CE01	2404-000139	C-TA,CHIP;10uF,20%,6.3V,-,3216,-,TP					
CE03	2203-000257	C-CERAMIC,CHIP;10nF,10%,50V,X7R,1608,-,T					
CE04	2203-000257	C-CERAMIC,CHIP;10nF,10%,50V,X7R,1608,-,T					
CE05	2203-000257	C-CERAMIC,CHIP;10nF,10%,50V,X7R,1608,-,T					
CE09	2203-001556	C-CERAMIC,CHIP;100nF,+80-20%,25V,Y5V,TP,					
CE10	2203-001556	C-CERAMIC,CHIP;100nF,+80-20%,25V,Y5V,TP,					
CE11	2203-001556	C-CERAMIC,CHIP;100nF,+80-20%,25V,Y5V,TP,					
CE12	2203-000477	C-CERAMIC,CHIP;1uF,+80-20%,16V,Y5V,TP,20					
CE13	2203-001556	C-CERAMIC,CHIP;100nF,+80-20%,25V,Y5V,TP,					
CE14	2404-000107	C-TA,CHIP;100nF,20%,35V,-,TP,3216,-					
CE15	2404-000107	C-TA,CHIP;100nF,20%,35V,-,TP,3216,-					
CE16	2203-001634	C-CERAMIC,CHIP;33nF,10%,50V,X7R,TP,1608,					
CE17	2203-001556	C-CERAMIC,CHIP;100nF,+80-20%,25V,Y5V,TP,					
CE18	2404-000153	C-TA,CHIP;1uF,20%,20V,-,3216,-,TP					
CE20	2203-001556	C-CERAMIC,CHIP;100nF,+80-20%,25V,Y5V,TP,					
CE21	2404-000153	C-TA,CHIP;1uF,20%,20V,-,3216,-,TP					
CE22	2404-000204	C-TA,CHIP;3.3uF,20%,10V,-,3216,-,TP					
CE23	2203-000257	C-CERAMIC,CHIP;10nF,10%,50V,X7R,1608,-,T					
CE25	2404-000153	C-TA,CHIP;1uF,20%,20V,-,3216,-,TP					
CE26	2404-000251	C-TA,CHIP;470nF,20%,35V,-,3216,-,TP					
CE27	2404-000204	C-TA,CHIP;3.3uF,20%,10V,-,3216,-,TP					
CE28	2203-000715	C-CERAMIC,CHIP;3.3nF,10%,50V,X7R,TP,1608					
CE29	2203-001607	C-CERAMIC,CHIP;220pF,5%,50V,CH,1608,1.6m					
CE30	2203-000257	C-CERAMIC,CHIP;10nF,10%,50V,X7R,1608,-,T					
CE31	2203-001683	C-CERAMIC,CHIP;68PF,5%,50V,CH,TP,1608,1.					
CE32	2404-000139	C-TA,CHIP;10uF,20%,6.3V,-,3216,-,TP					
CE33	2203-001556	C-CERAMIC,CHIP;100nF,+80-20%,25V,Y5V,TP,					
CE34	2203-000477	C-CERAMIC,CHIP;1uF,+80-20%,16V,Y5V,TP,20					
CE35	2203-001656	C-CERAMIC,CHIP;470pF,5%,50V,CH,1608,1.6m					
CE36	2203-000491	C-CERAMIC,CHIP;2.2nF,10%,50V,X7R,TP,1608					
CE37	2203-000477	C-CERAMIC,CHIP;1uF,+80-20%,16V,Y5V,TP,20					
CE38	2203-000477	C-CERAMIC,CHIP;1uF,+80-20%,16V,Y5V,TP,20					
CE39	2203-000477	C-CERAMIC,CHIP;1uF,+80-20%,16V,Y5V,TP,20					
CE40	2404-000153	C-TA,CHIP;1uF,20%,20V,-,3216,-,TP					
CE42	2203-001556	C-CERAMIC,CHIP;100nF,+80-20%,25V,Y5V,TP,					
CE43	2404-000112	C-TA,CHIP;100uF,20%,6.3V,WT,7343,-,TP					
CE44	2404-000153	C-TA,CHIP;1uF,20%,20V,-,3216,-,TP					
CE45	2203-001556	C-CERAMIC,CHIP;100nF,+80-20%,25V,Y5V,TP,					
CE46	2404-000139	C-TA,CHIP;10uF,20%,6.3V,-,3216,-,TP					
CE50	2404-000139	C-TA,CHIP;10uF,20%,6.3V,-,3216,-,TP					
CE51	2203-001556	C-CERAMIC,CHIP;100nF,+80-20%,25V,Y5V,TP,					

---

## 8. Block Diagrams

---

	Page
8-1 Overall Block Diagram (Camera) - - - - -	8-2
8-2 Overall Block Diagram (VCR) - - - - -	8-3
8-3 DC/DC Converter - - - - -	8-4
8-4 Drum Servo - - - - -	8-5
8-5 Capstan Servo - - - - -	8-6
8-6 Video Playback - - - - -	8-7
8-7 Video Record - - - - -	8-8
8-8 Audio(Mono) - - - - -	8-9
8-9 Camera Main/CCD - - - - -	8-10

### 8-1 Overall Block Diagram (Camera)

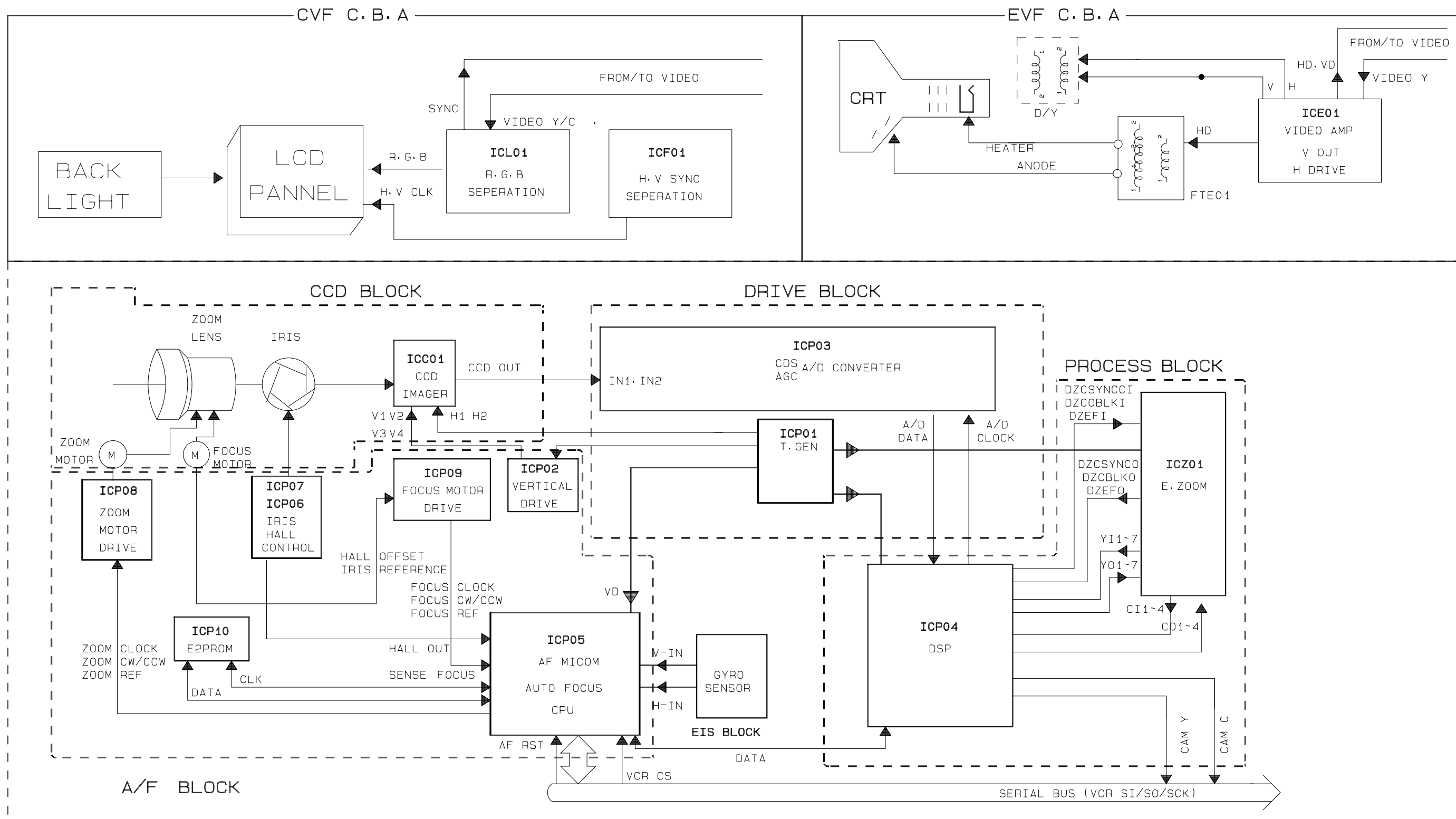

8-2 Overall Block Diagram (VCR)

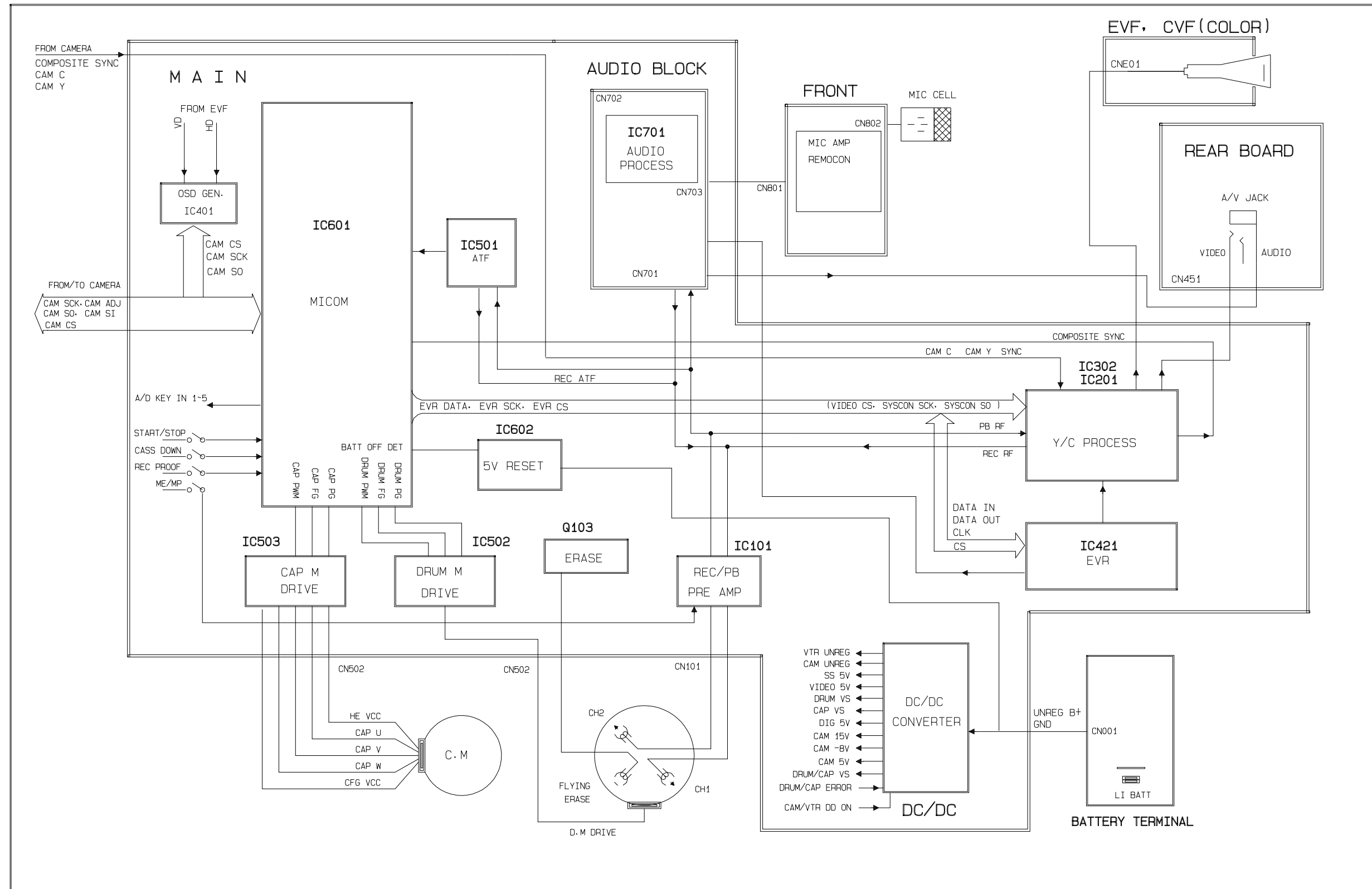

### 8-3 DC/DC Converter

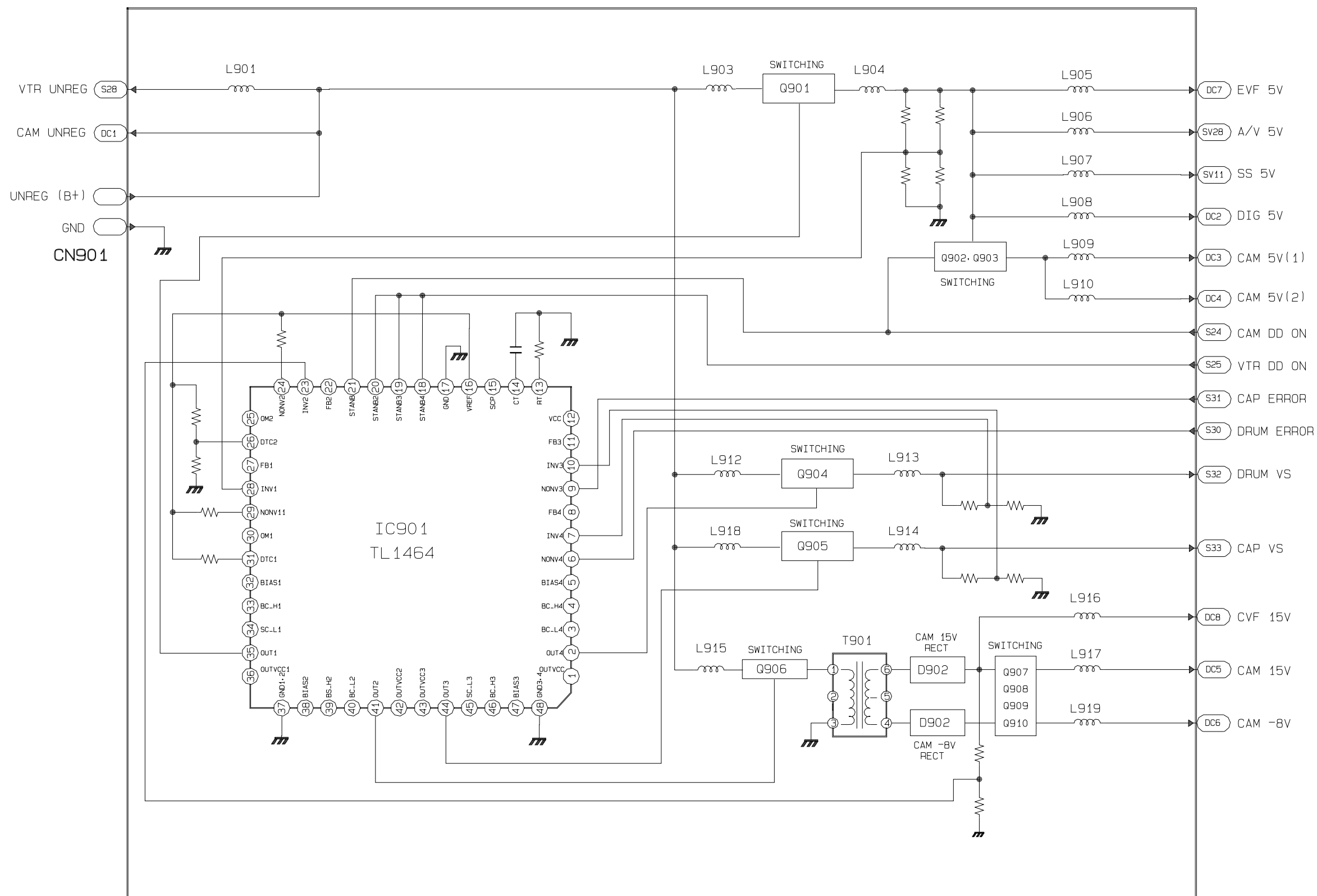

8-4 Drum Servo

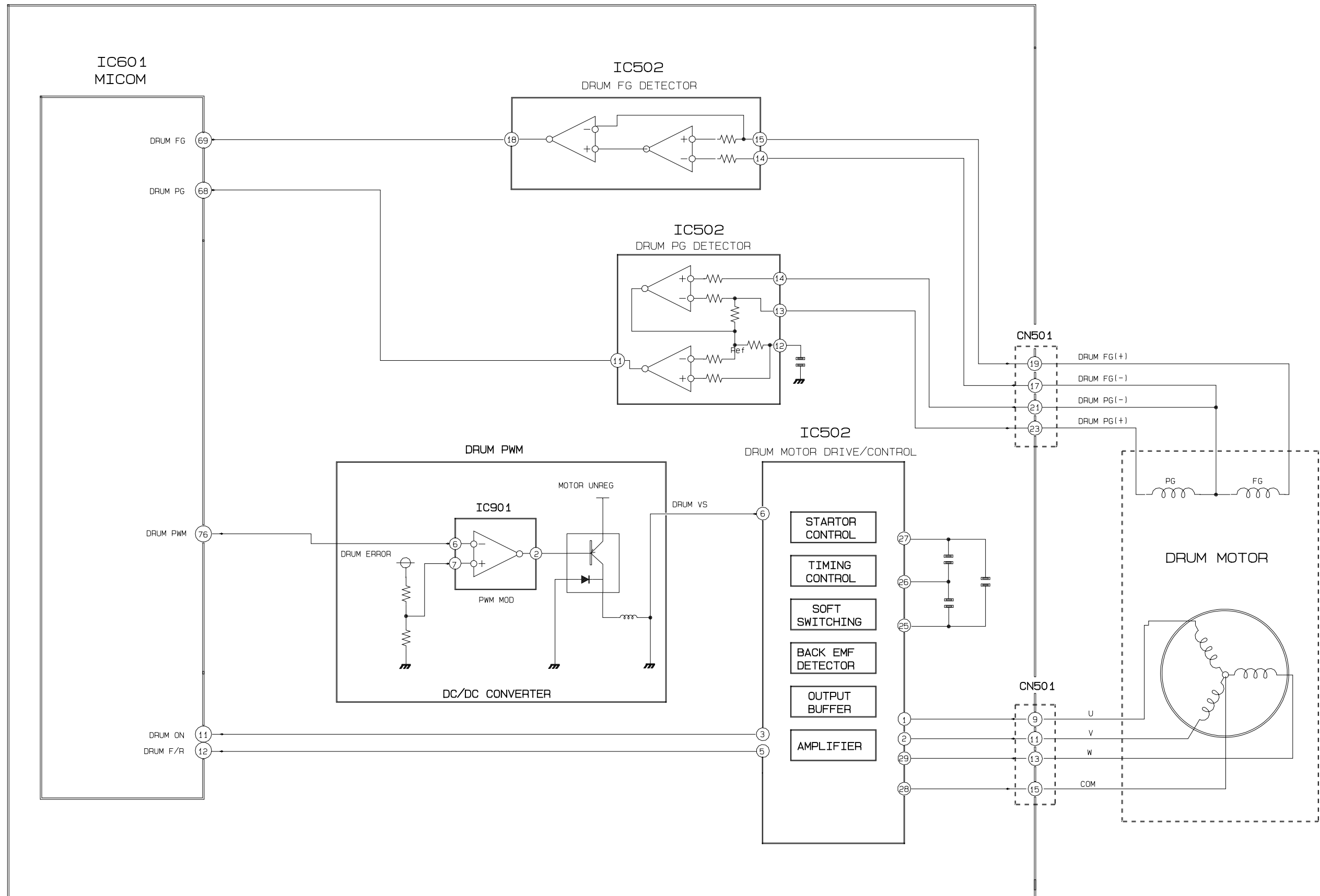

### 8-5 Capstan Servo

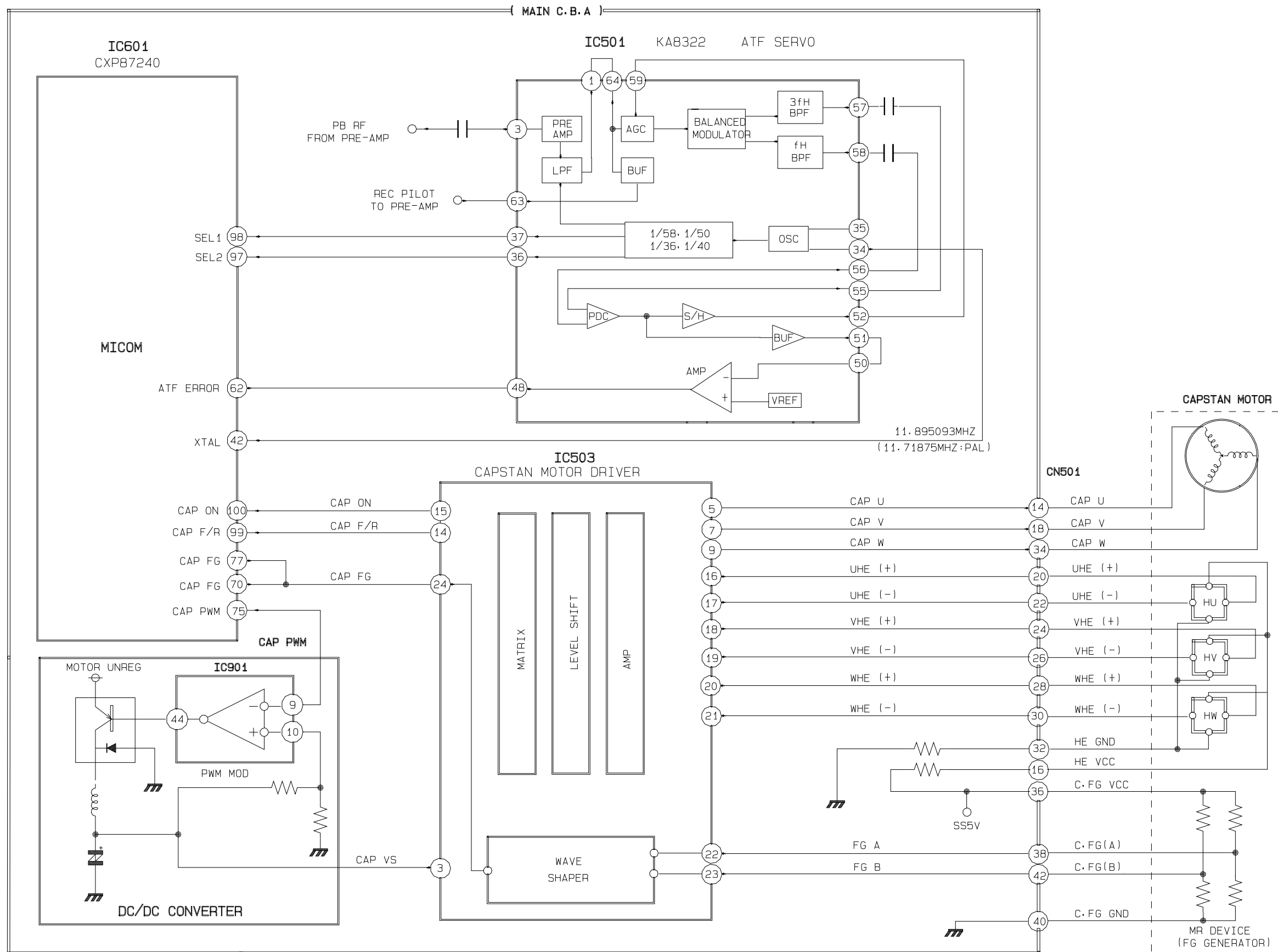

8-6 Video Playback

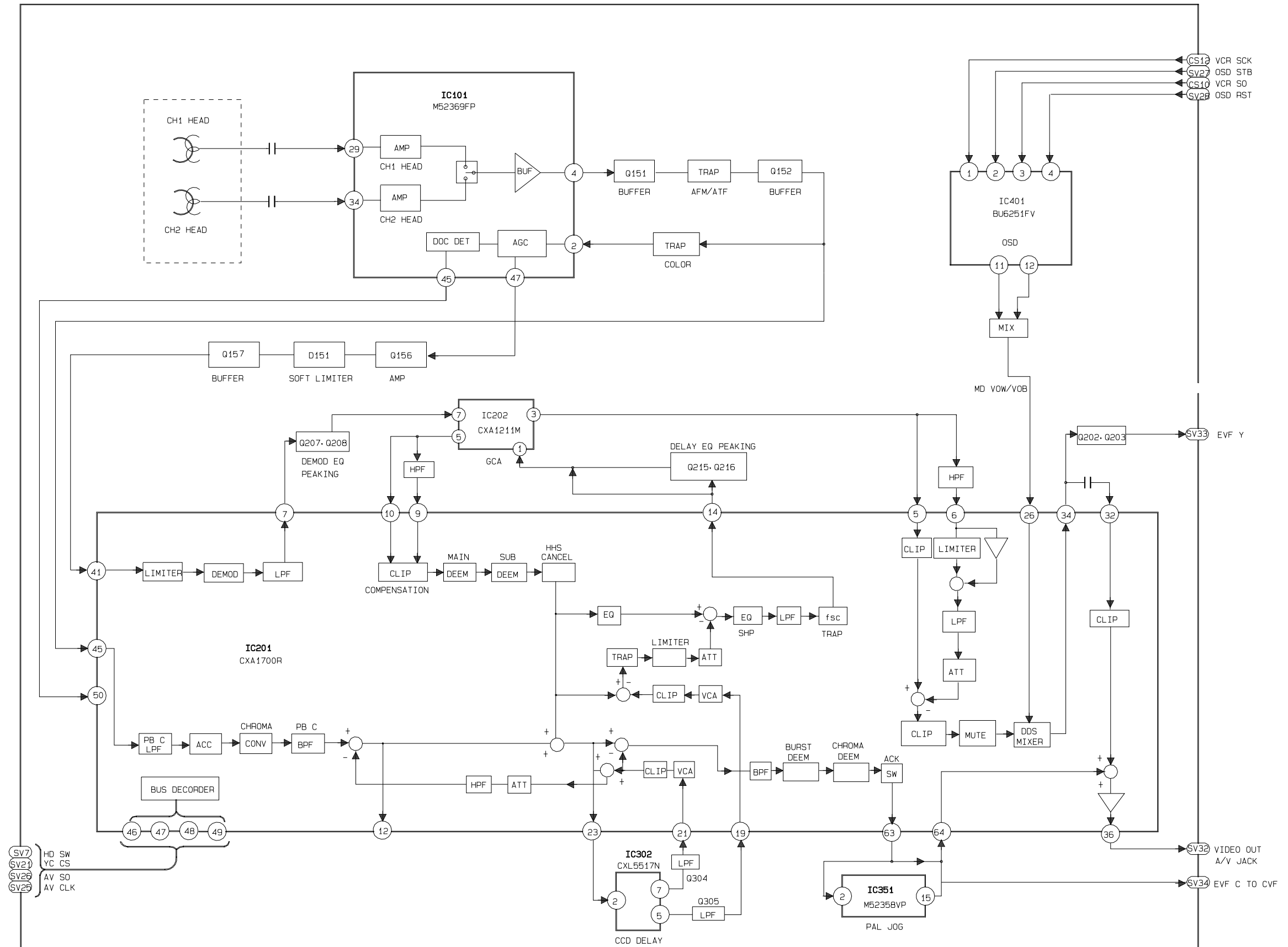

### 8-7 Video Record

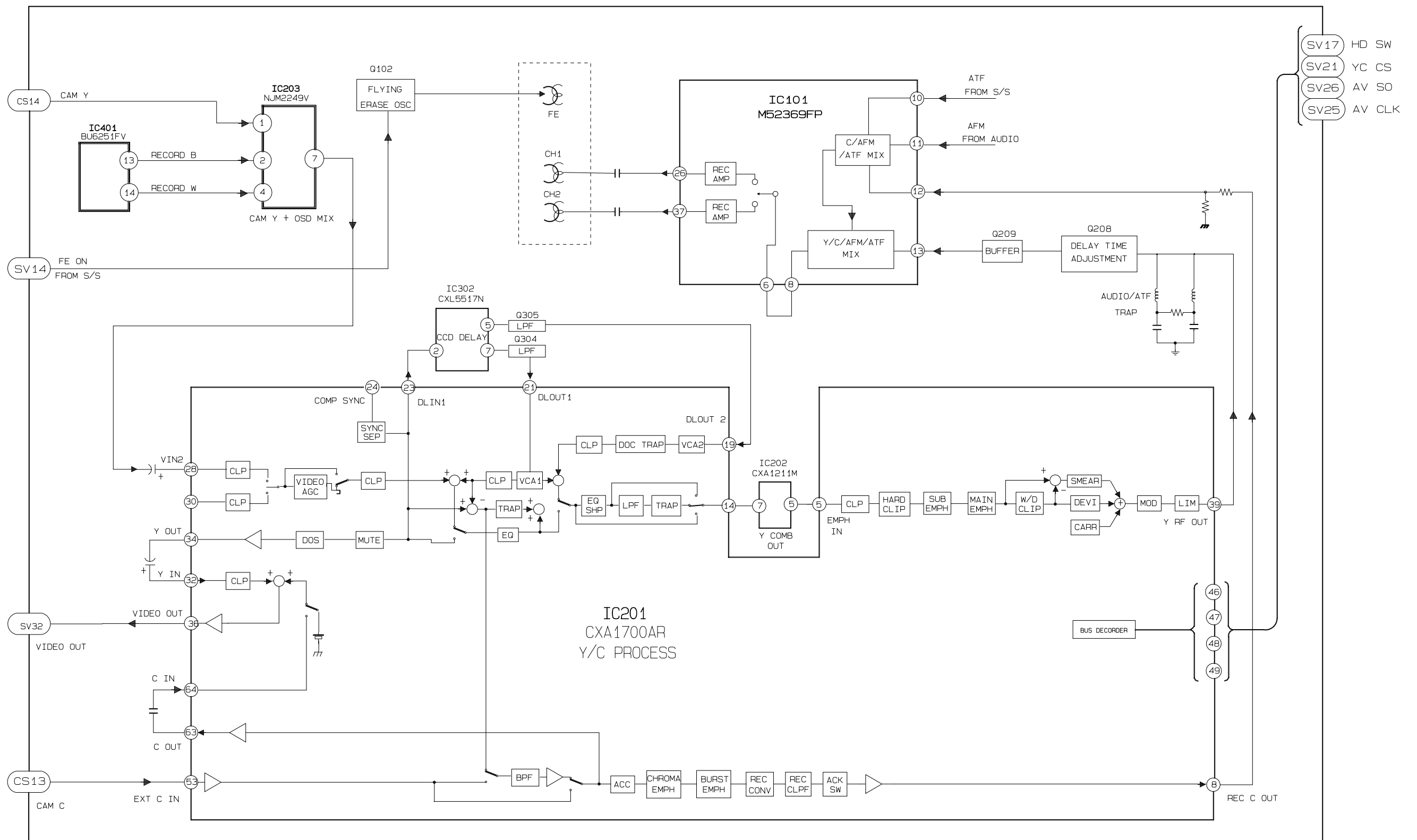

8-8 Audio

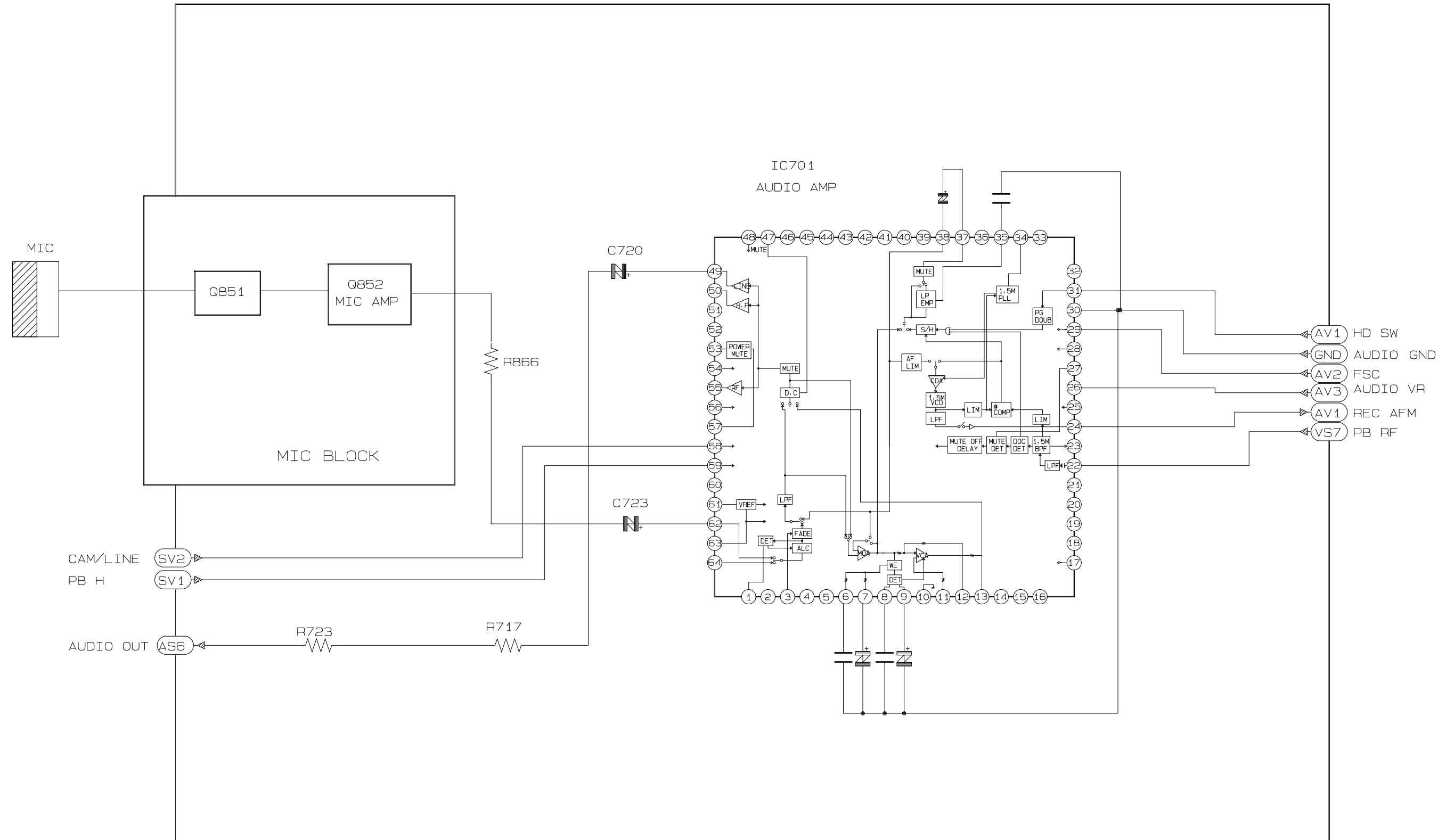



---

## 9. PCB Diagrams

---

	Page
9-1 Main .....	9-2
9-2 Rear .....	9-4
9-3 Front .....	9-5
9-4 Terminal .....	9-5
9-5 CVF (VP-A21/A23) .....	9-6
9-6 EVF (VP-A20/A22) .....	9-6
9-7 CCD .....	9-7

### 9-1 Main

I C	TRANSISTOR	COIL
IC101 (C1)	Q154 (C1)	L157 (C1)
IC201 (E1)	Q156 (C1)	L158 (D1)
IC203 (D2)	Q157 (D1)	L207 (E1)
IC302 (E1)	Q201 (D1)	L301 (E0)
IC401 (B2)	Q206 (D1)	L302 (E0)
IC421 (D1)	Q207 (D1)	L401 (B2)
IC503 (C1)	Q210 (D1)	L402 (B2)
IC601 (B1)	Q211 (E1)	L901 (B2)
IC602 (B1)	Q219 (E1)	L902 (B2)
IC701 (F1)	Q220 (E1)	L903 (B2)
ICP01 (D2)	Q222 (D1)	L904 (B3)
ICP02 (D2)	Q223 (D1)	L905 (B2)
ICP05 (C2)	Q303 (E1)	L906 (B2)
ICP06 (C2)	Q304 (E1)	L907 (B2)
ICP07 (D3)	Q306 (E0)	L908 (C2)
ICP08 (C3)	Q381 (C2)	L909 (B3)
ICP09 (C3)	Q382 (C2)	L910 (B3)
ICP12 (D2)	Q401 (B2)	L912 (B3)
ICS04 (D3)	Q702 (E2)	L913 (B2)
	Q851 (F2)	L914 (B3)
	Q903 (B3)	L915 (B3)
	QP01 (C2)	L916 (B3)
	QP02 (C3)	L917 (B3)
		L918 (B3)
		L919 (B3)
		LP01 (D2)
		LP03 (D2)
		LP05 (D3)
		LP06 (D3)
		LP12 (D3)
		LP13 (D3)
		LP20 (D3)
		LP21 (D3)
		LP22 (D3)
		LP23 (D3)
		LP24 (D3)
		LP25 (D3)
		LP26 (D3)
		LP27 (D3)
		LP28 (D3)
		LP29 (D3)
		LP30 (D3)
		LP31 (D3)
		LP32 (D3)
		LP33 (D3)
		LP34 (D3)
		LP35 (D3)
		LP36 (D3)
		LP37 (D3)
		LP38 (D3)
		LP39 (D3)
		LP40 (D3)
		LP41 (D3)
		LP42 (D3)
		LP43 (D3)
		LP44 (D3)
		LP45 (D3)
		LP46 (D3)
		LP47 (D3)
		LP48 (D3)
		LP49 (D3)
		LP50 (D3)
		LP51 (D3)
		LP52 (D3)
		LP53 (D3)
		LP54 (D3)
		LP55 (D3)
		LP56 (D3)
		LP57 (D3)
		LP58 (D3)
		LP59 (D3)
		LP60 (D3)
		LP61 (D3)
		LP62 (D3)
		LP63 (D3)
		LP64 (D3)
		LP65 (D3)
		LP66 (D3)
		LP67 (D3)
		LP68 (D3)
		LP69 (D3)
		LP70 (D3)
		LP71 (D3)
		LP72 (D3)
		LP73 (D3)
		LP74 (D3)
		LP75 (D3)
		LP76 (D3)
		LP77 (D3)
		LP78 (D3)
		LP79 (D3)
		LP80 (D3)
		LP81 (D3)
		LP82 (D3)
		LP83 (D3)
		LP84 (D3)
		LP85 (D3)
		LP86 (D3)
		LP87 (D3)
		LP88 (D3)
		LP89 (D3)
		LP90 (D3)
		LP91 (D3)
		LP92 (D3)
		LP93 (D3)
		LP94 (D3)
		LP95 (D3)
		LP96 (D3)
		LP97 (D3)
		LP98 (D3)
		LP99 (D3)
		LP100 (D3)
		LP101 (D3)
		LP102 (D3)
		LP103 (D3)
		LP104 (D3)
		LP105 (D3)
		LP106 (D3)
		LP107 (D3)
		LP108 (D3)
		LP109 (D3)
		LP110 (D3)
		LP111 (D3)
		LP112 (D3)
		LP113 (D3)
		LP114 (D3)
		LP115 (D3)
		LP116 (D3)
		LP117 (D3)
		LP118 (D3)
		LP119 (D3)
		LP120 (D3)
		LP121 (D3)
		LP122 (D3)
		LP123 (D3)
		LP124 (D3)
		LP125 (D3)
		LP126 (D3)
		LP127 (D3)
		LP128 (D3)
		LP129 (D3)
		LP130 (D3)
		LP131 (D3)
		LP132 (D3)
		LP133 (D3)
		LP134 (D3)
		LP135 (D3)
		LP136 (D3)
		LP137 (D3)
		LP138 (D3)
		LP139 (D3)
		LP140 (D3)
		LP141 (D3)
		LP142 (D3)
		LP143 (D3)
		LP144 (D3)
		LP145 (D3)
		LP146 (D3)
		LP147 (D3)
		LP148 (D3)
		LP149 (D3)
		LP150 (D3)
		LP151 (D3)
		LP152 (D3)
		LP153 (D3)
		LP154 (D3)
		LP155 (D3)
		LP156 (D3)
		LP157 (D3)
		LP158 (D3)
		LP159 (D3)
		LP160 (D3)
		LP161 (D3)
		LP162 (D3)
		LP163 (D3)
		LP164 (D3)
		LP165 (D3)
		LP166 (D3)
		LP167 (D3)
		LP168 (D3)
		LP169 (D3)
		LP170 (D3)
		LP171 (D3)
		LP172 (D3)
		LP173 (D3)
		LP174 (D3)
		LP175 (D3)
		LP176 (D3)
		LP177 (D3)
		LP178 (D3)
		LP179 (D3)
		LP180 (D3)
		LP181 (D3)
		LP182 (D3)
		LP183 (D3)
		LP184 (D3)
		LP185 (D3)
		LP186 (D3)
		LP187 (D3)
		LP188 (D3)
		LP189 (D3)
		LP190 (D3)
		LP191 (D3)
		LP192 (D3)
		LP193 (D3)
		LP194 (D3)
		LP195 (D3)
		LP196 (D3)
		LP197 (D3)
		LP198 (D3)
		LP199 (D3)
		LP200 (D3)
		LP201 (D3)
		LP202 (D3)
		LP203 (D3)
		LP204 (D3)
		LP205 (D3)
		LP206 (D3)
		LP207 (D3)
		LP208 (D3)
		LP209 (D3)
		LP210 (D3)
		LP211 (D3)
		LP212 (D3)
		LP213 (D3)
		LP214 (D3)
		LP215 (D3)
		LP216 (D3)
		LP217 (D3)
		LP218 (D3)
		LP219 (D3)
		LP220 (D3)
		LP221 (D3)
		LP222 (D3)
		LP223 (D3)
		LP224 (D3)
		LP225 (D3)
		LP226 (D3)
		LP227 (D3)
		LP228 (D3)
		LP229 (D3)
		LP230 (D3)
		LP231 (D3)
		LP232 (D3)
		LP233 (D3)
		LP234 (D3)
		LP235 (D3)
		LP236 (D3)
		LP237 (D3)
		LP238 (D3)
		LP239 (D3)
		LP240 (D3)
		LP241 (D3)
		LP242 (D3)
		LP243 (D3)
		LP244 (D3)
		LP245 (D3)
		LP246 (D3)
		LP247 (D3)
		LP248 (D3)
		LP249 (D3)
		LP250 (D3)
		LP251 (D3)
		LP252 (D3)
		LP253 (D3)
		LP254 (D3)
		LP255 (D3)
		LP256 (D3)
		LP257 (D3)
		LP258 (D3)
		LP259 (D3)
		LP260 (D3)
		LP261 (D3)
		LP262 (D3)
		LP263 (D3)
		LP264 (D3)
		LP265 (D3)
		LP266 (D3)
		LP267 (D3)
		LP268 (D3)
		LP269 (D3)
		LP270 (D3)
		LP271 (D3)
		LP272 (D3)
		LP273 (D3)
		LP274 (D3)
		LP275 (D3)
		LP276 (D3)
		LP277 (D3)
		LP278 (D3)
		LP279 (D3)
		LP280 (D3)
		LP281 (D3)
		LP282 (D3)
		LP283 (D3)
		LP284 (D3)
		LP285 (D3)
		LP286 (D3)
		LP287 (D3)
		LP288 (D3)
		LP289 (D3)
		LP290 (D3)
		LP291 (D3)
		LP292 (D3)
		LP293 (D3)
		LP294 (D3)
		LP295 (D3)
		LP296 (D3)
		LP297 (D3)
		LP298 (D3)
		LP299 (D3)
		LP300 (D3)
		LP301 (D3)
		LP302 (D3)
		LP303 (D3)
		LP304 (D3)
		LP305 (D3)
		LP306 (D3)
		LP307 (D3)
		LP308 (D3)
		LP309 (D3)
		LP310 (D3)
		LP311 (D3)
		LP312 (D3)
		LP313 (D3)
		LP314 (D3)
		LP315 (D3)
		LP316 (D3)
		LP317 (D3)
		LP318 (D3)
		LP319 (D3)
		LP320 (D3)
		LP321 (D3)
		LP322 (D3)
		LP323 (D3)
		LP324 (D3)
		LP325 (D3)
		LP326 (D3)
		LP327 (D3)
		LP328 (D3)
		LP329 (D3)
		LP330 (D3)
		LP331 (D3)
		LP332 (D3)
		LP333 (D3)
		LP334 (D3)
		LP335 (D3)
		LP336 (D3)
		LP337 (D3)
		LP338 (D3)
		LP339 (D3)
		LP340 (D3)
		LP341 (D3)
		LP342 (D3)
		LP343 (D3)
		LP344 (D3)
		LP345 (D3)
		LP346 (D3)
		LP347 (D3)
		LP348 (D3)
		LP349 (D3)
		LP350 (D3)
		LP351 (D3)
		LP352 (D3)
		LP353 (D3)
		LP354 (D3)
		LP355 (D3)
		LP356 (D3)
		LP357 (D3)
		LP358 (D3)
		LP359 (D3)
		LP360 (D3)
		LP361 (D3)
		LP362 (D3)
		LP363 (D3)
		LP364 (D3)
		LP365 (D3)
		LP366 (D3)
		LP367 (D3)
		LP368 (D3)
		LP369 (D3)
		LP370 (D3)
		LP371 (D3)
		LP372 (D3)
		LP373 (D3)
		LP374 (D3)
		LP375 (D3)
		LP376 (D3)
		LP377 (D3)
		LP378 (D3)
		LP379 (D3)
		LP380 (D3)
		LP381 (D3)
		LP382 (D3)
		LP383 (D3)
		LP384 (D3)
		LP385 (D3)
		LP386 (D3)
		LP387 (D3)
		LP388 (D3)
		LP389 (D3)
		LP390 (D3)
		LP391 (D3)
		LP392 (D3)
		LP393 (D3)
		LP394 (D3)
		LP395 (D3)
		LP396 (D3)
		LP397 (D3)
		LP398 (D3)
		LP399 (D3)
		LP400 (D3)
		LP401 (D3)
		LP402 (D3)
		LP403 (D3)
		LP404 (D3)
		LP405 (D3)
		LP406 (D3)
		LP407 (D3)
		LP408 (D3)
		LP409 (D3)
		LP410 (D3)
		LP411 (D3)
		LP412 (D3)
		LP413 (D3)
		LP414 (D3)
		LP415 (D3)
		LP416 (D3)
		LP417 (D3)
		LP418 (D3)
		LP419 (D3)
		LP420 (D3)
		LP421 (D3)
		LP422 (D3)
		LP423 (D3)
		LP424 (D3)
		LP425 (D3)
		LP426 (D3)
		LP427 (D3)
		LP428 (D3)
		LP429 (D3)
		LP430 (D3)
		LP431 (D3)
		LP432 (D3)
		LP433 (D3)
		LP434 (D3)
		LP435 (D3)
		LP436 (D3)
		LP437 (D3)
		LP438 (D3)
		LP439 (D3)
		LP440 (D3)
		LP441 (D3)
		LP442 (D3)
		LP443 (D3)
		LP444 (D3)
		LP445 (D3)
		LP446 (D3)
		LP447 (D3)
		LP448 (D3)
		LP449 (D3)
		LP450 (D3)
		LP451 (D3)
		LP452 (D3)
		LP453 (D3)
		LP454 (D3)
		LP455 (D3)
		LP456 (D3)
		LP457 (D3)
		LP458 (D3)
		LP459 (D3)
		LP460 (D3)
		LP461 (D3)
		LP462 (D3)
		LP463 (D3)
		LP464 (D3)
		LP465 (D3)
		LP466 (D3)
		LP467 (D3)
		LP468 (D3)



## 9-2 Rear

---



(Component Side)

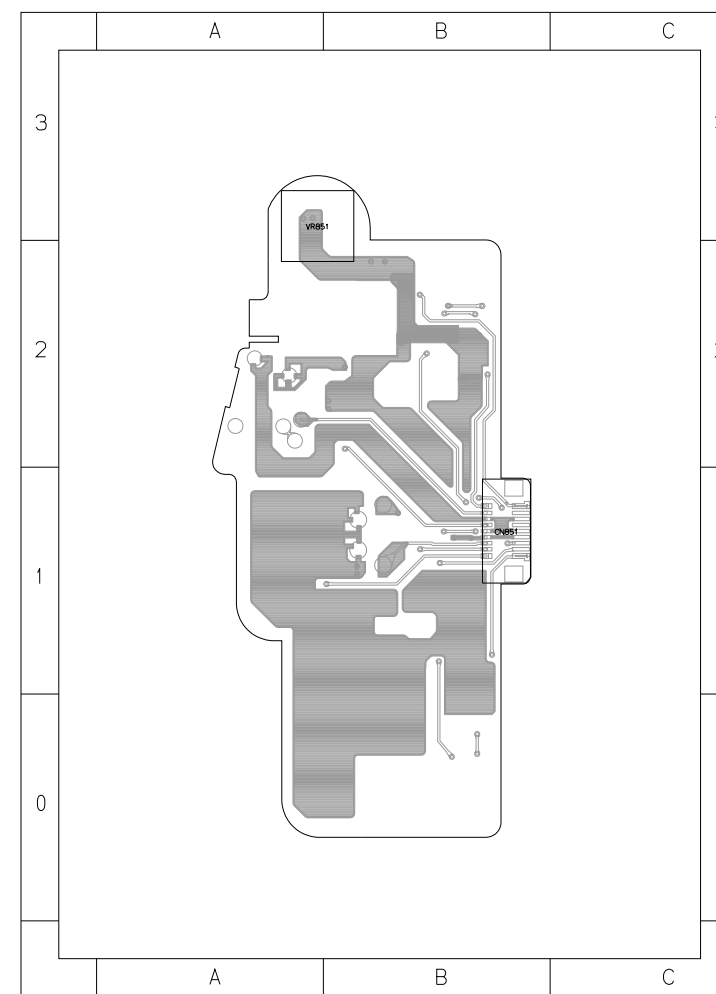

(Conductor Side)

9-3 Front

9-4 Terminal

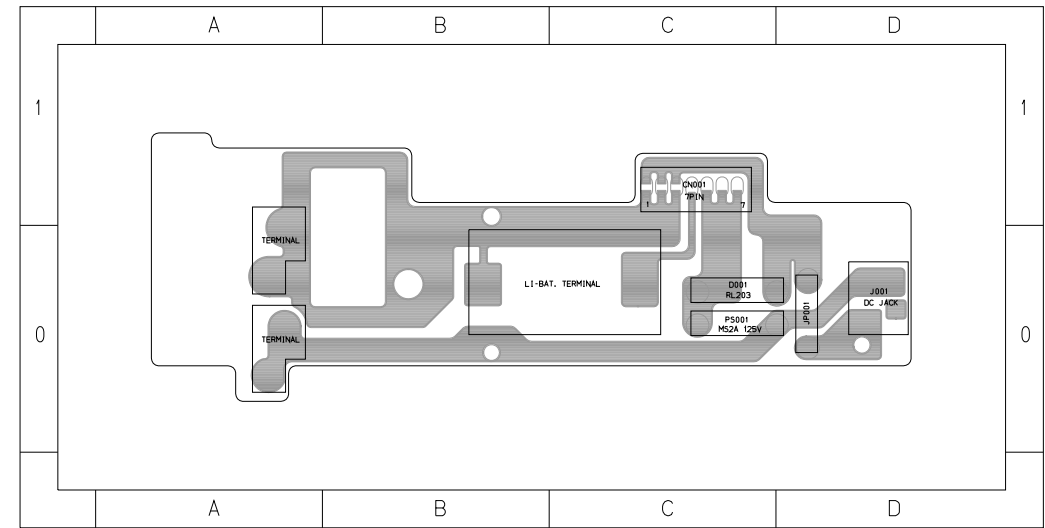
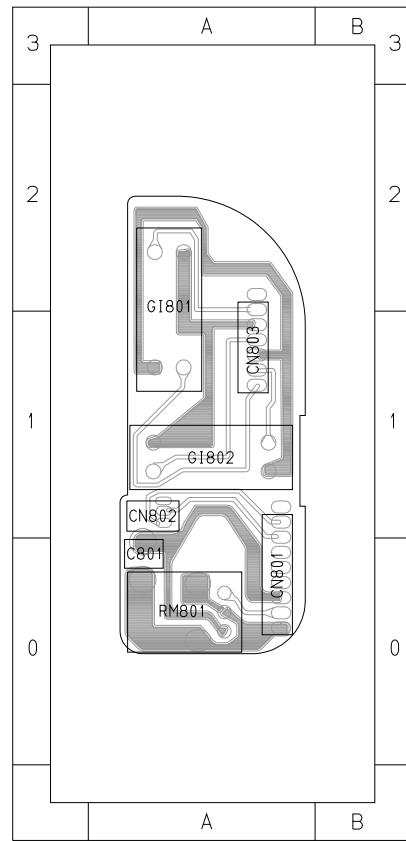



9-7 CCD

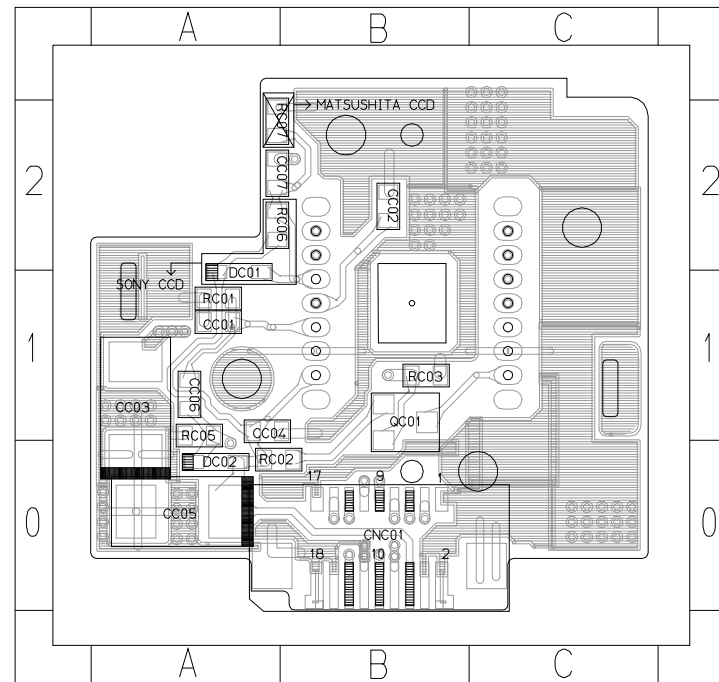

CNC01 0B  
QC01 1B

(Component Side)

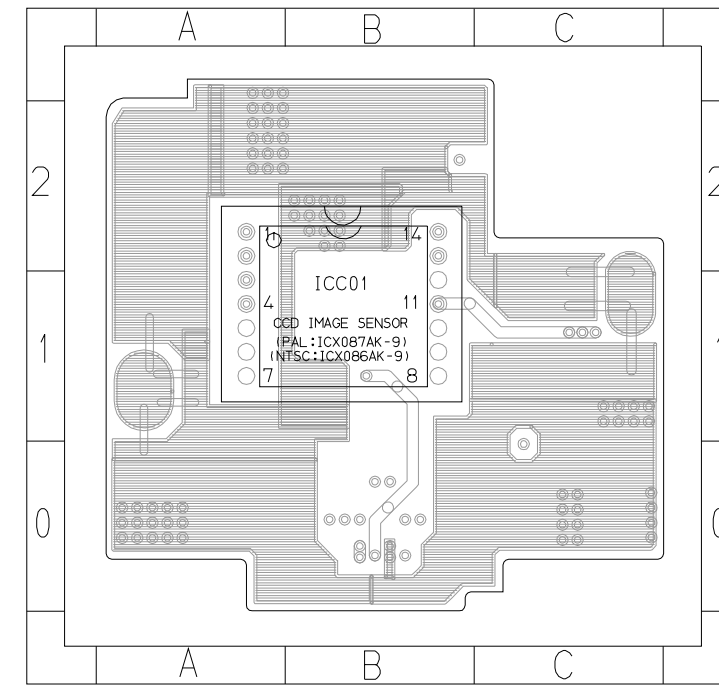

ICC01 1B

(Conductor Side)

## MEMO

### 9-1 MAIN -2 ( COMPONENT - PATTERN )

---

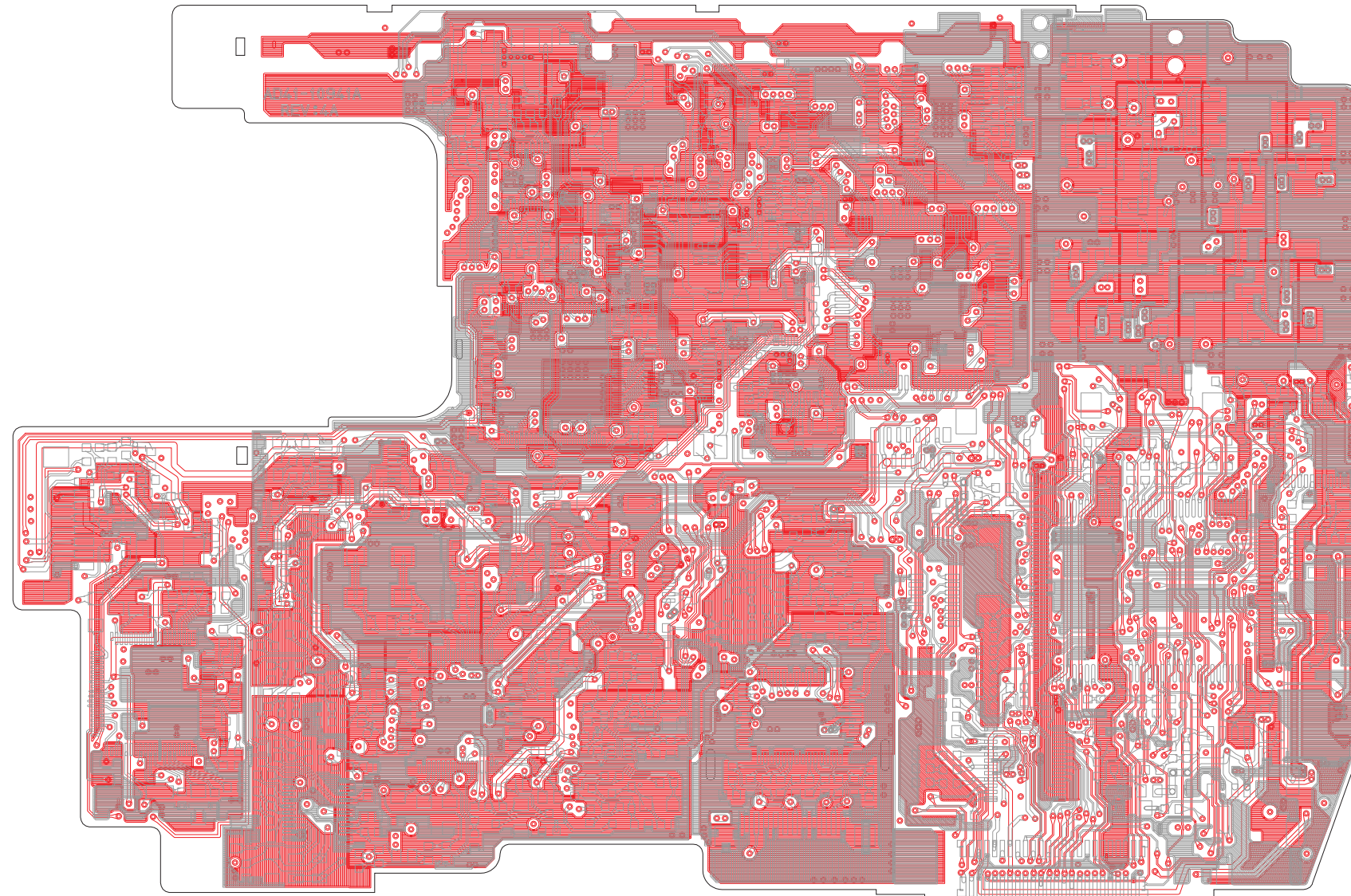

## 9-1 MAIN 2 (CONDUCTOR - PATTERN)

---

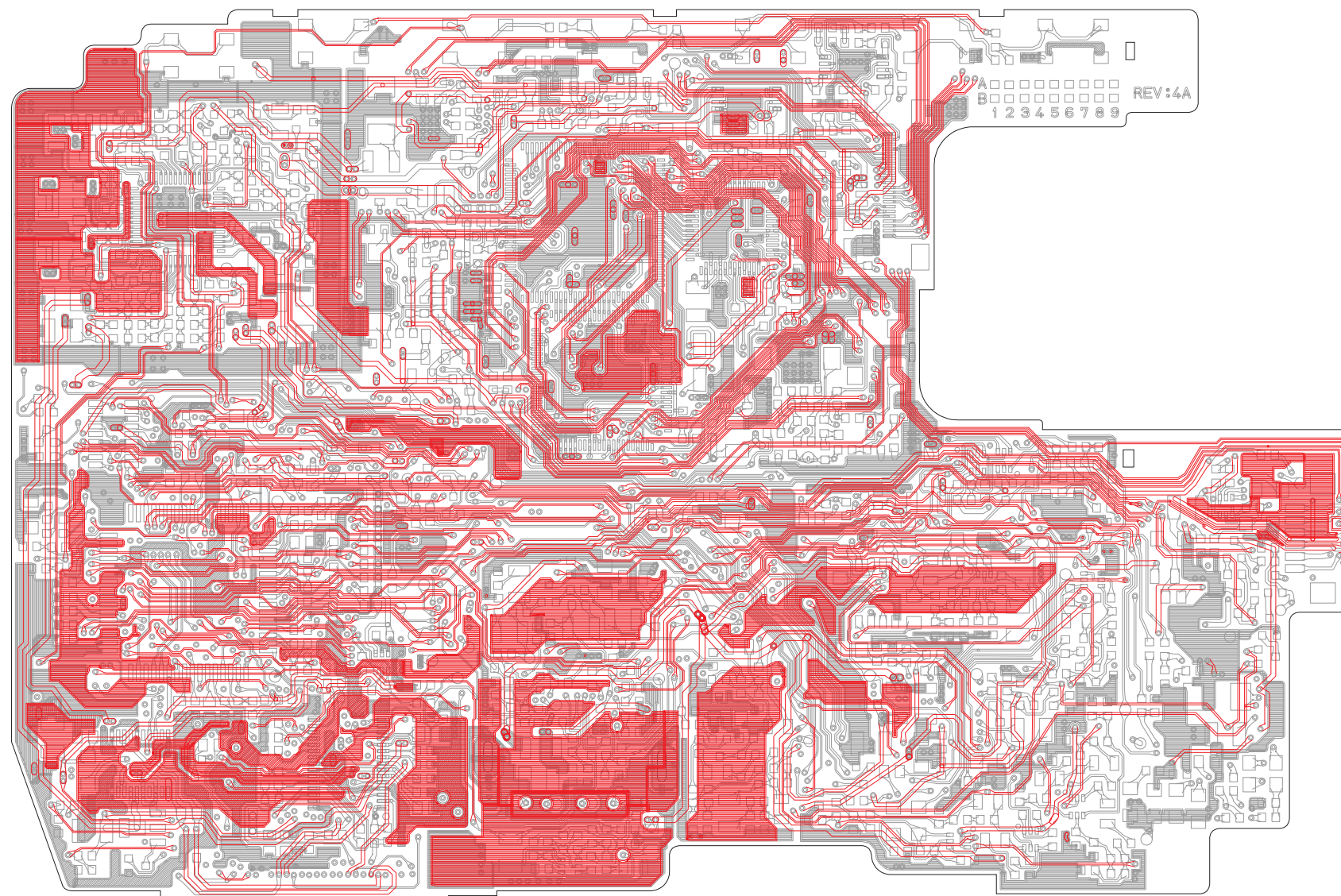

9-7 CCD (pattern)

---

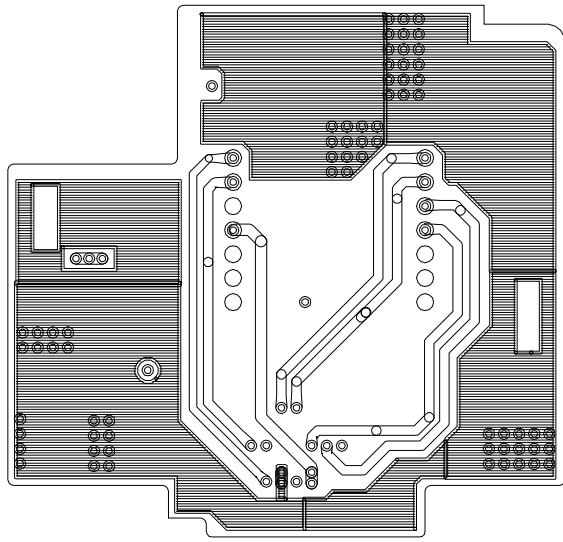

(Component Side)

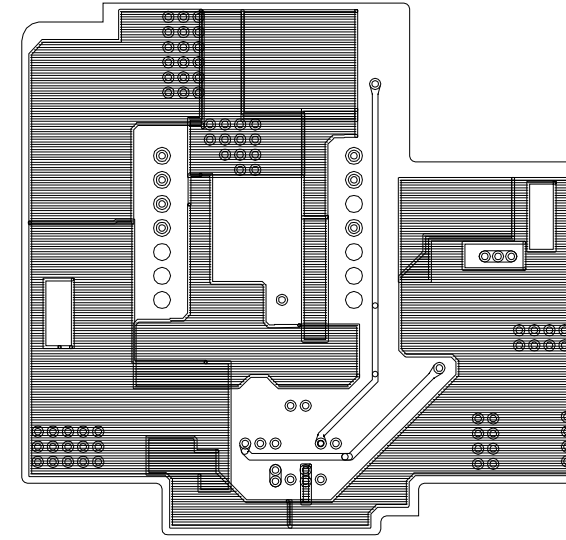

(Conductor Side)

# 10. Wiring Diagram

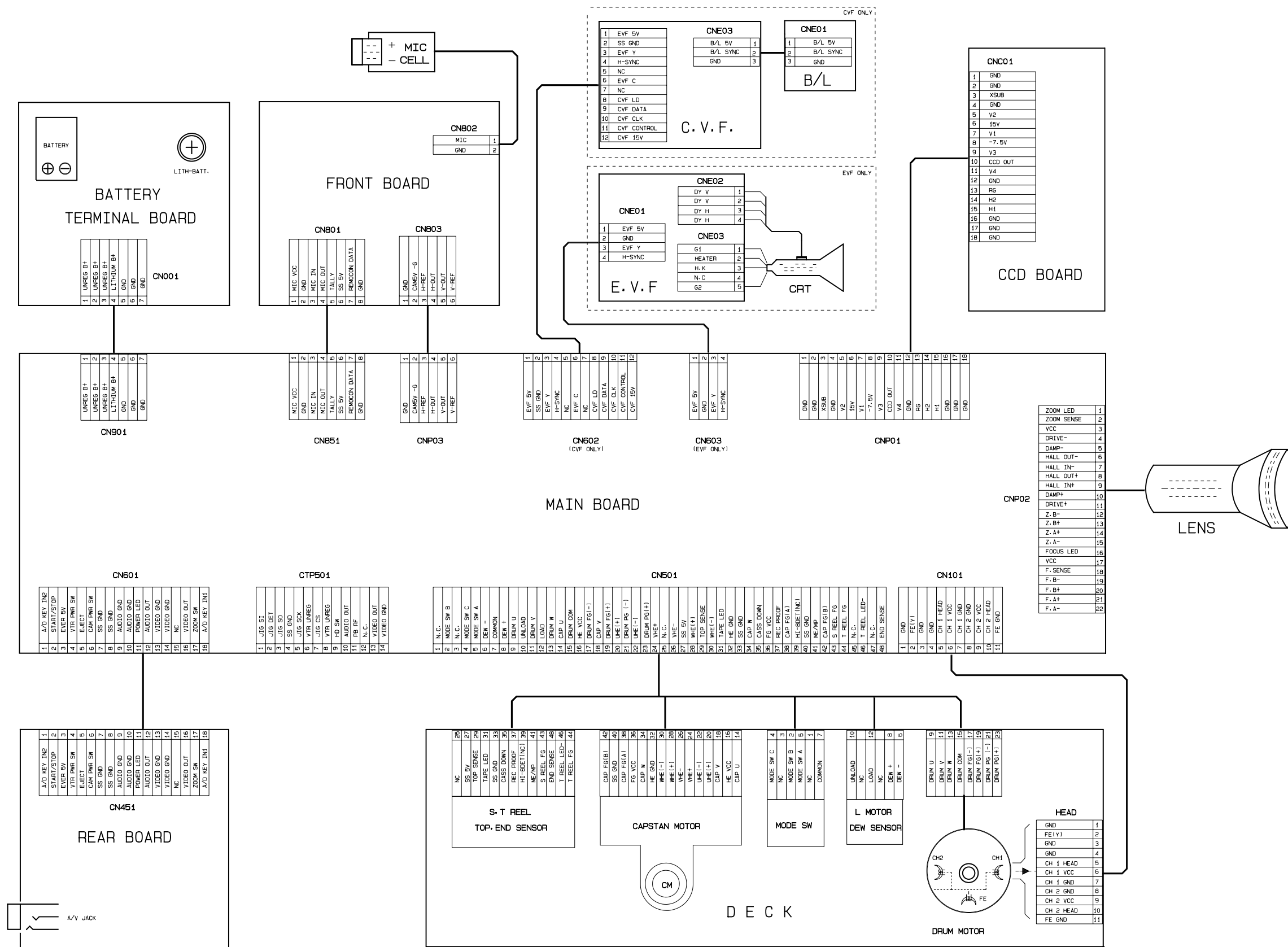

---

## 11. Schematic Diagrams

---

	Page
◆ Block Identification of Main PCB .....	11-2
11-1 DC/DC Converter .....	11-3
11-2 System Control/Servo .....	11-4
11-3 Video .....	11-5
11-4 Audio (Mono) .....	11-6
11-5 Rear .....	11-7
11-6 Terminal .....	11-8
11-7 Camera Main/EIS .....	11-9
11-8 CCD .....	11-10
11-9 EVF(VP-A20/A22) .....	11-11
11-10 CVF(VP-A21/A23) .....	11-12
11-11 Adaptor .....	11-13
11-14 Front .....	11-14

**Note**

For schematic Diagram  
 - Resistors are in ohms, 1/8W unless otherwise noted.  
 - Circled numbers refer to waveforms.

**Special note :**

Most semiconductor devices are electrostatically sensitive and therefore require the special handling techniques described under the "electrostatically sensitive (ES) devices" section of this service manual.

**Note :**

Do not use the part number shown on this drawing for ordering. The correct part number is shown in the parts list (may be slightly different or amended since this drawing was prepared).

**Important safety notices :**

Components identified with the mark  have the special characteristics for safety. When replacing any of these components. Use only the same type.

◆ **Block Identification of Main PCB**

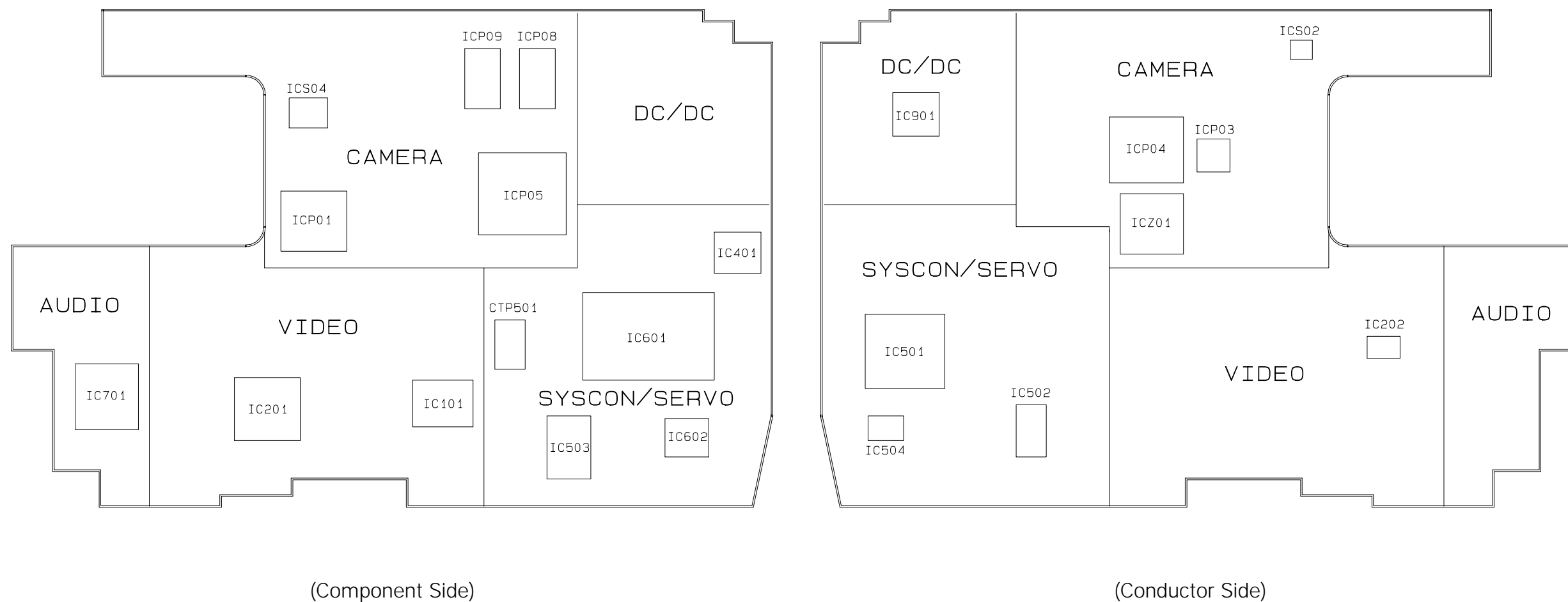

# 11-1 DC/DC Converter

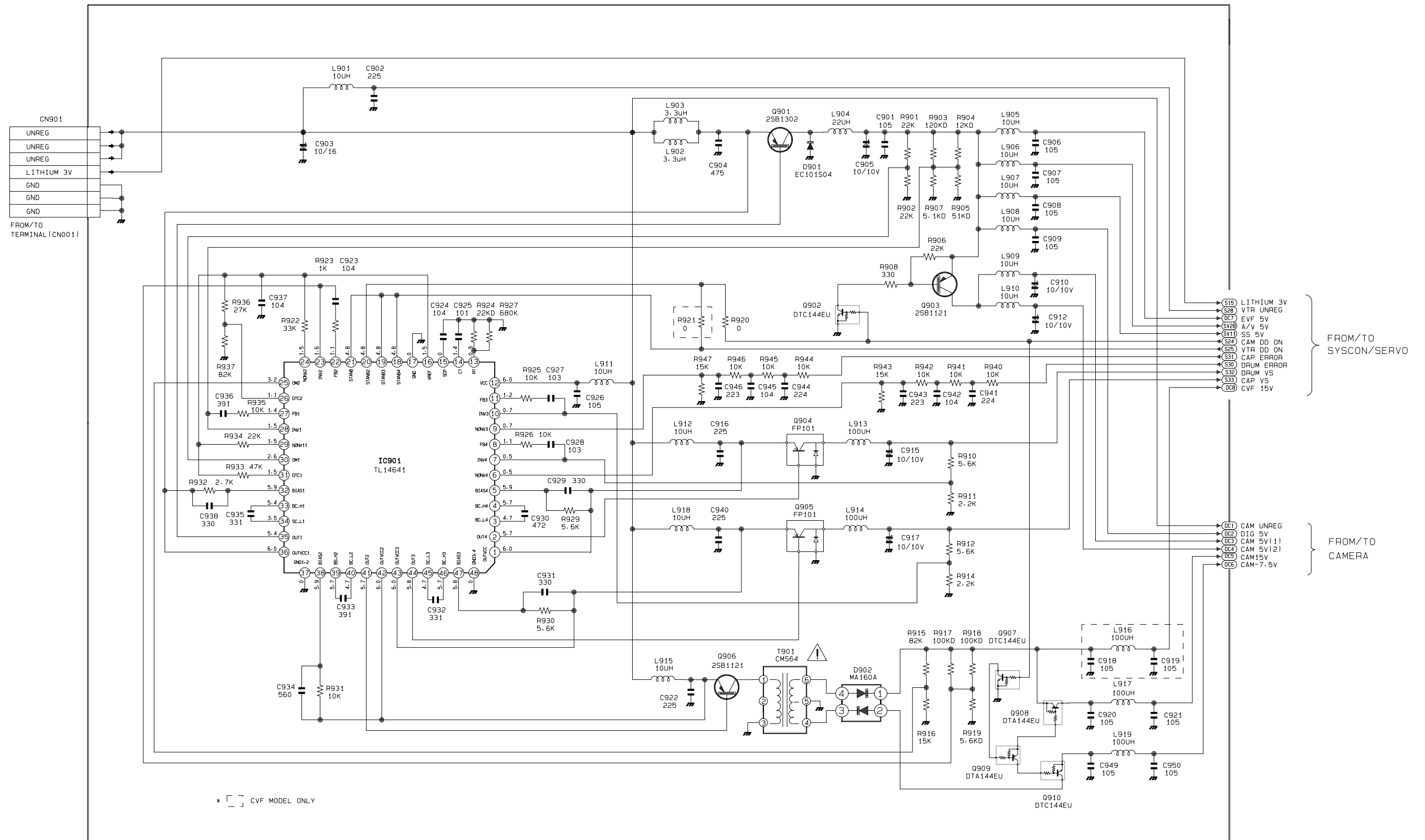

# 11-2 System Control/Servo

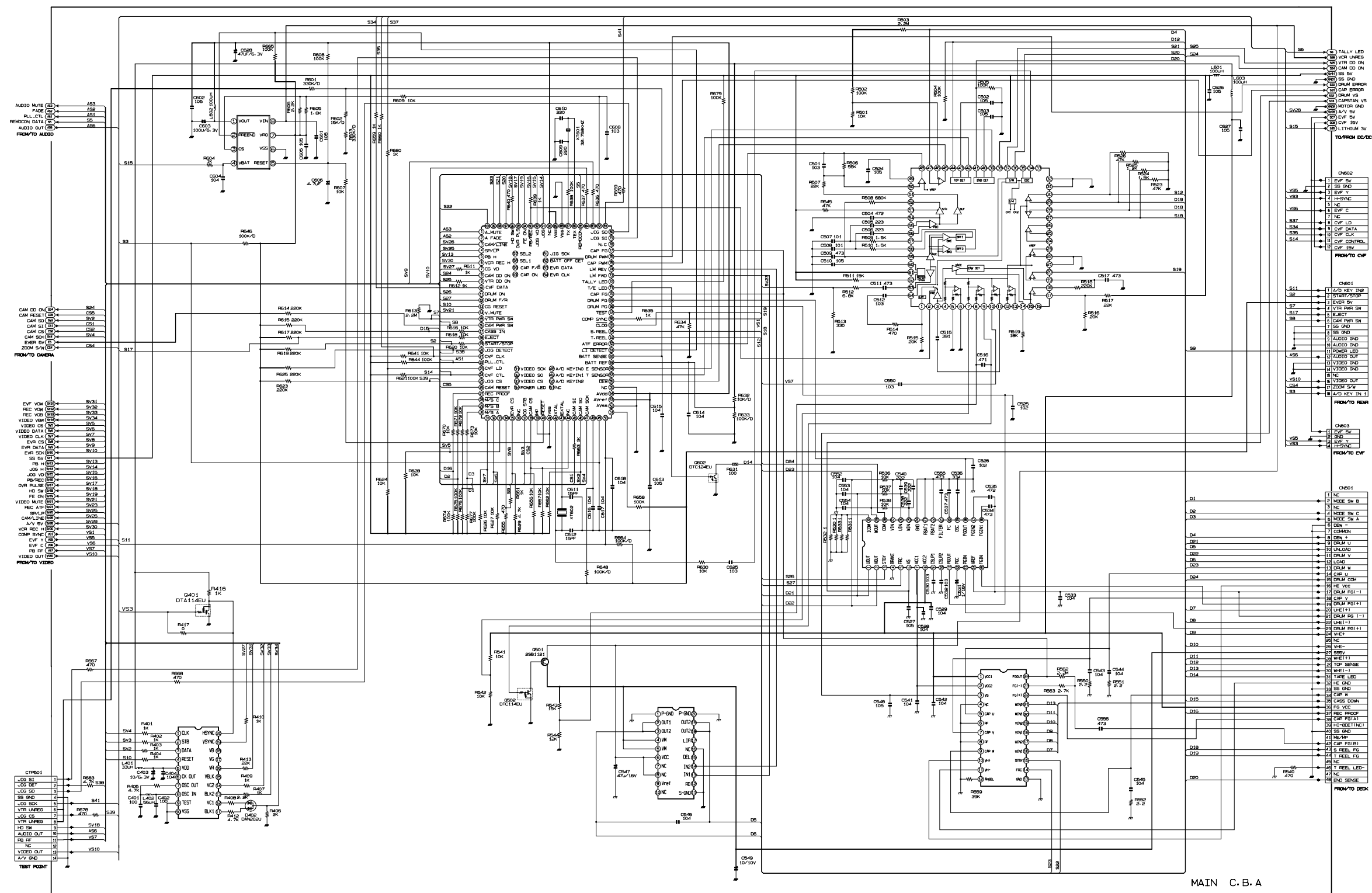

MAIN C.B. A

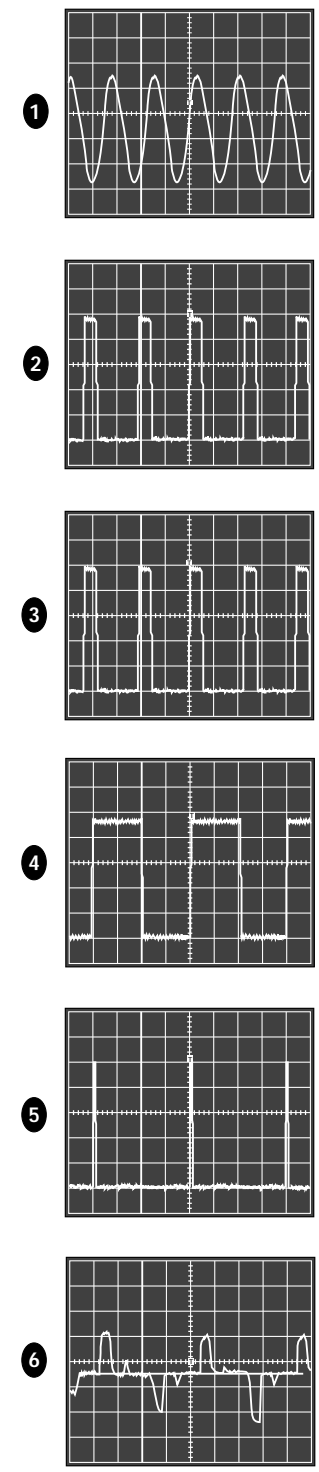

### 11-3 Video

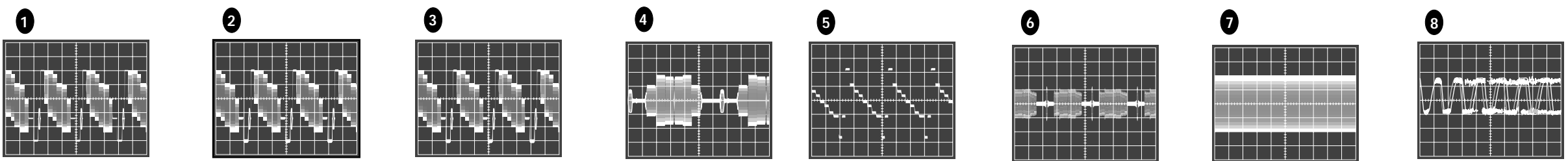
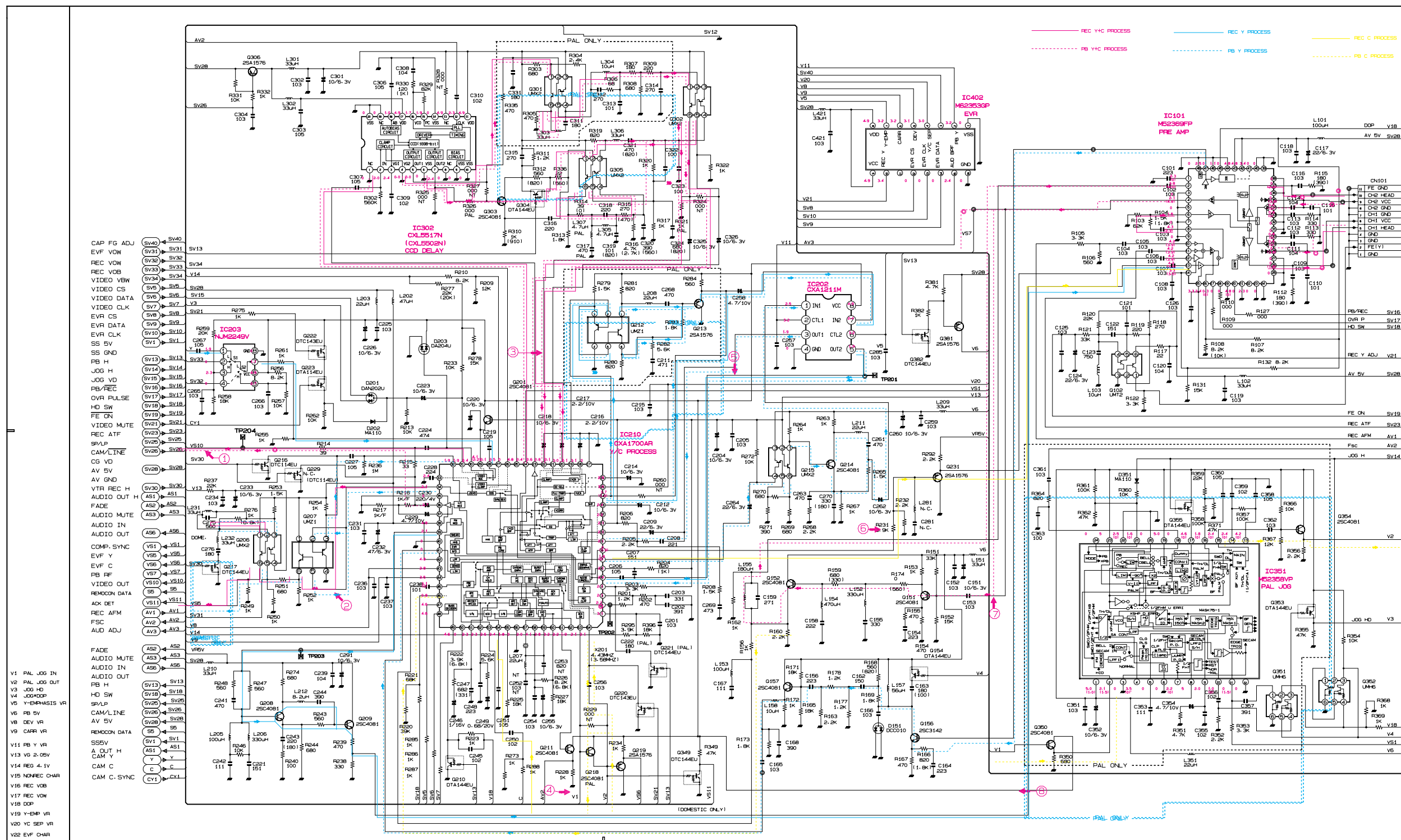

### 11-4 Audio (Mono)

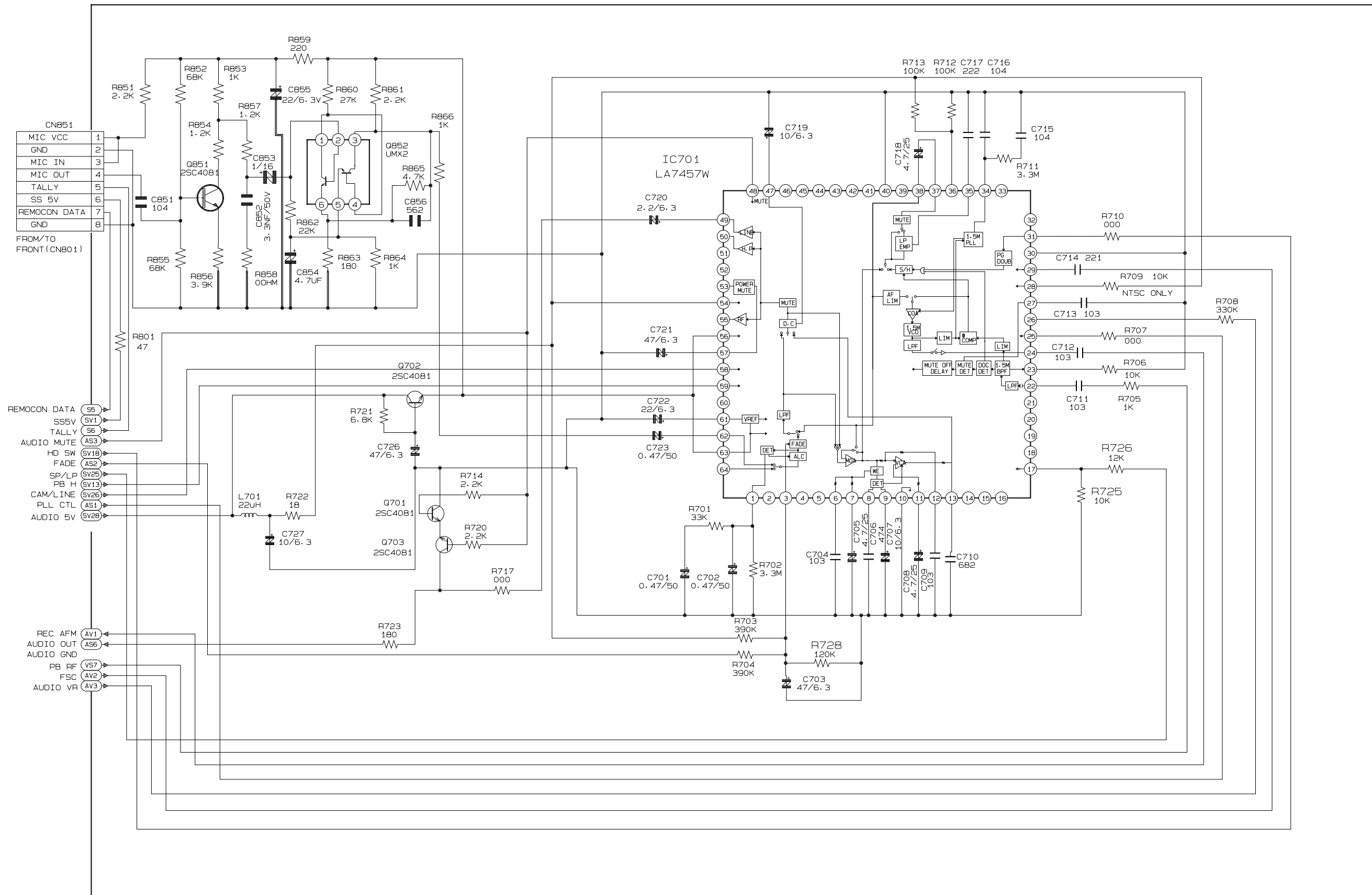

11-5 Rear

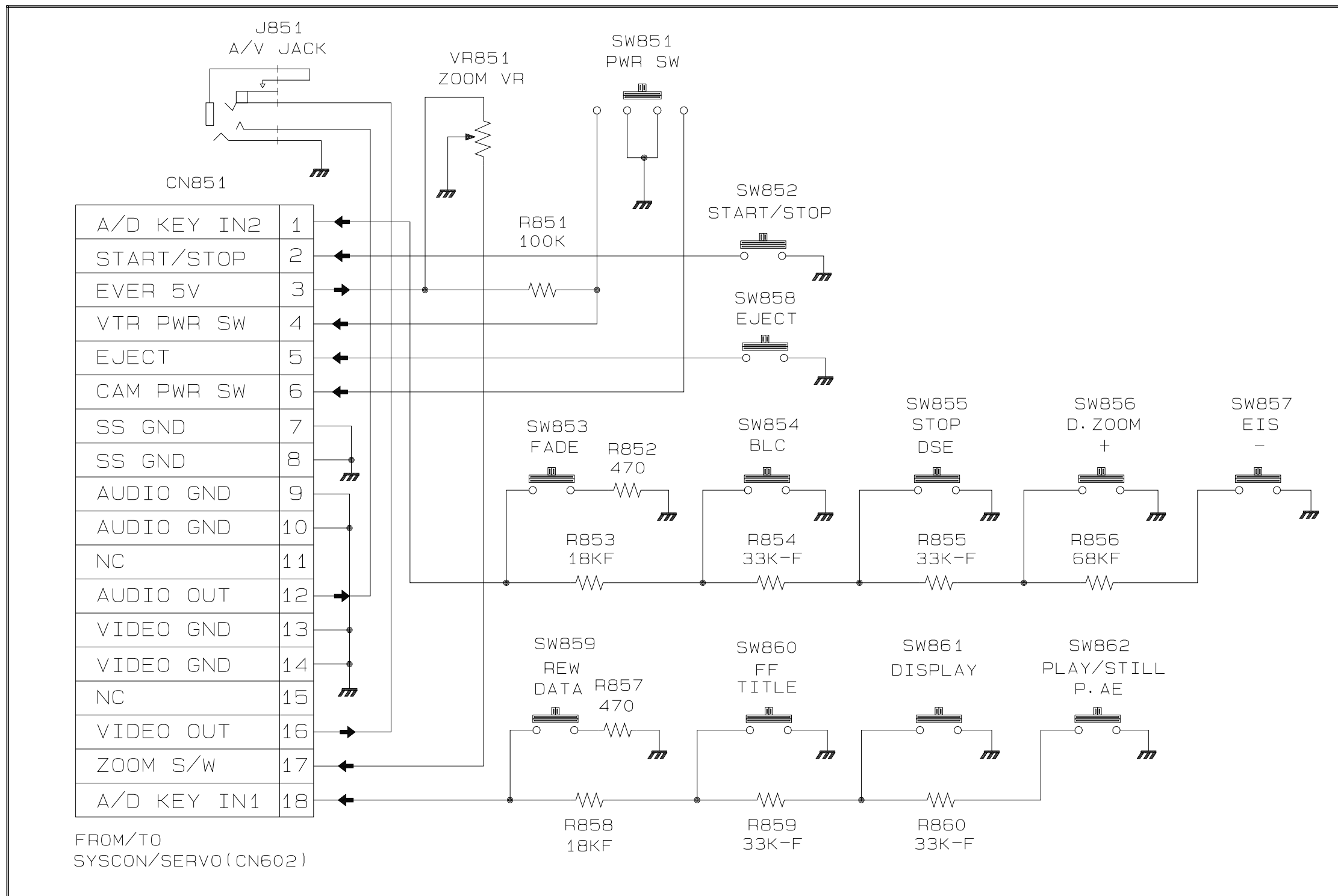

### 11-6 Terminal

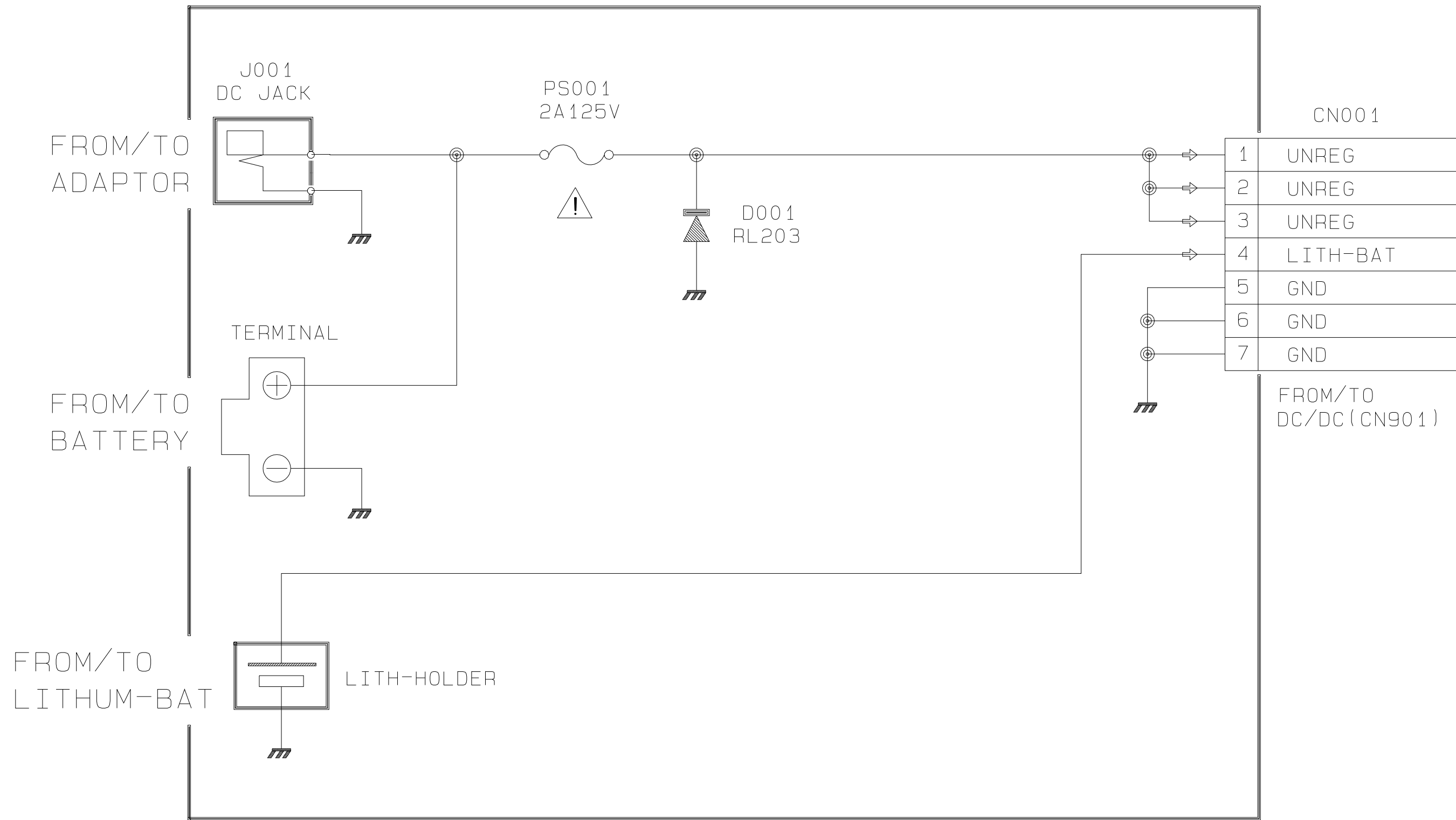

# 11-7 Camera Main

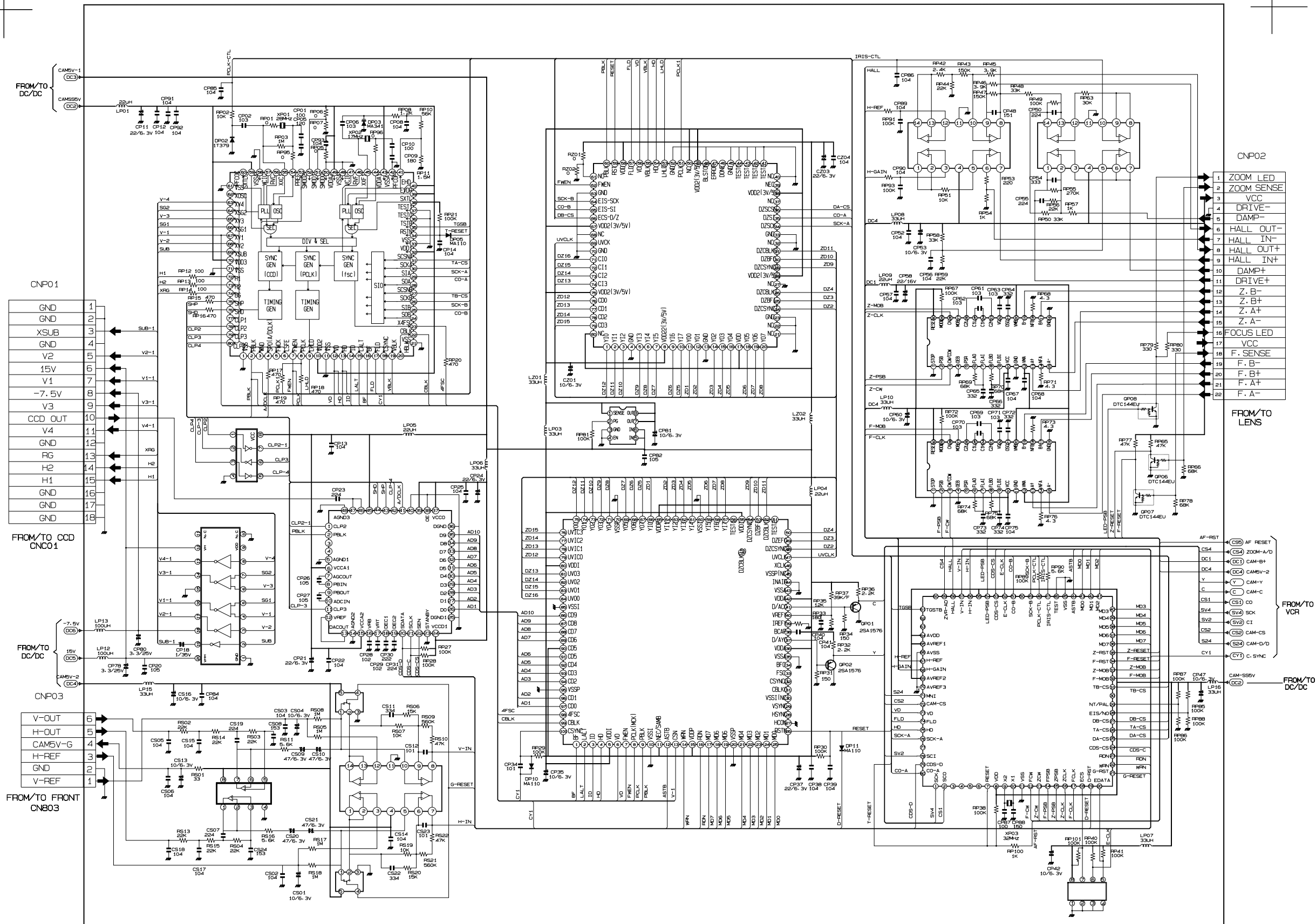

- 1
- 2
- 3
- 4
- 5
- 6
- 7

11-8 CCD

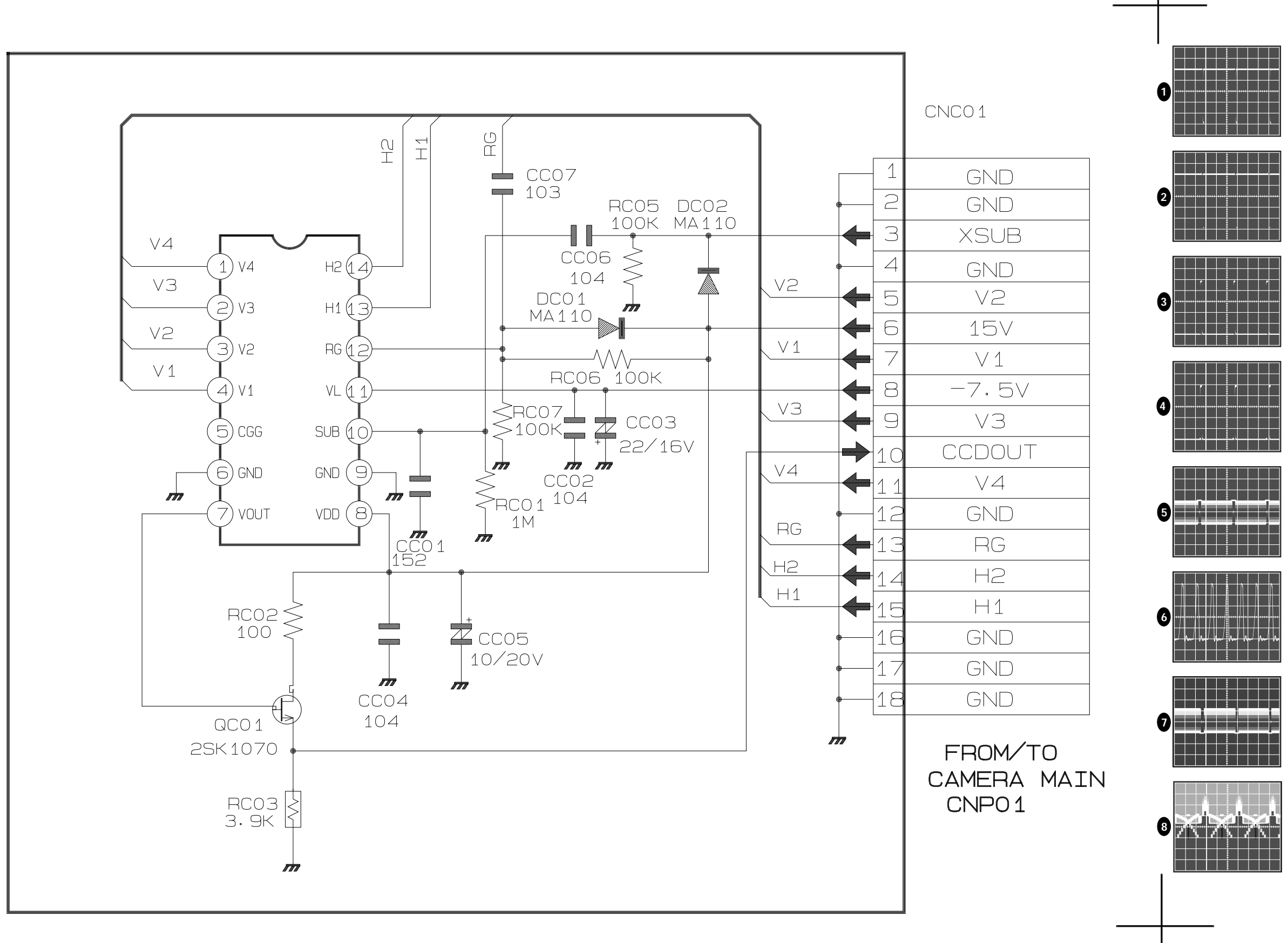

1

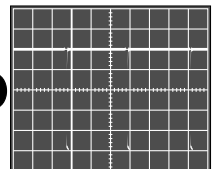

2

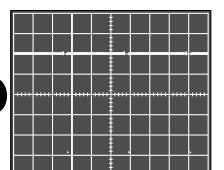

3

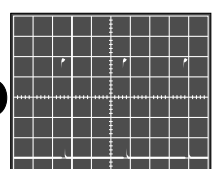

4

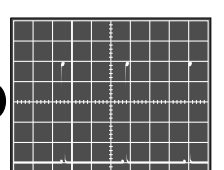

5

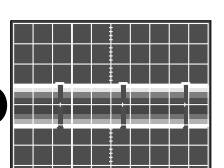

6

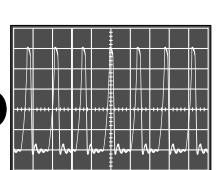

7

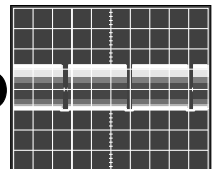

8

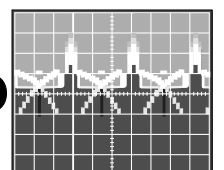

11-9 EVF (VP-A20/A22)

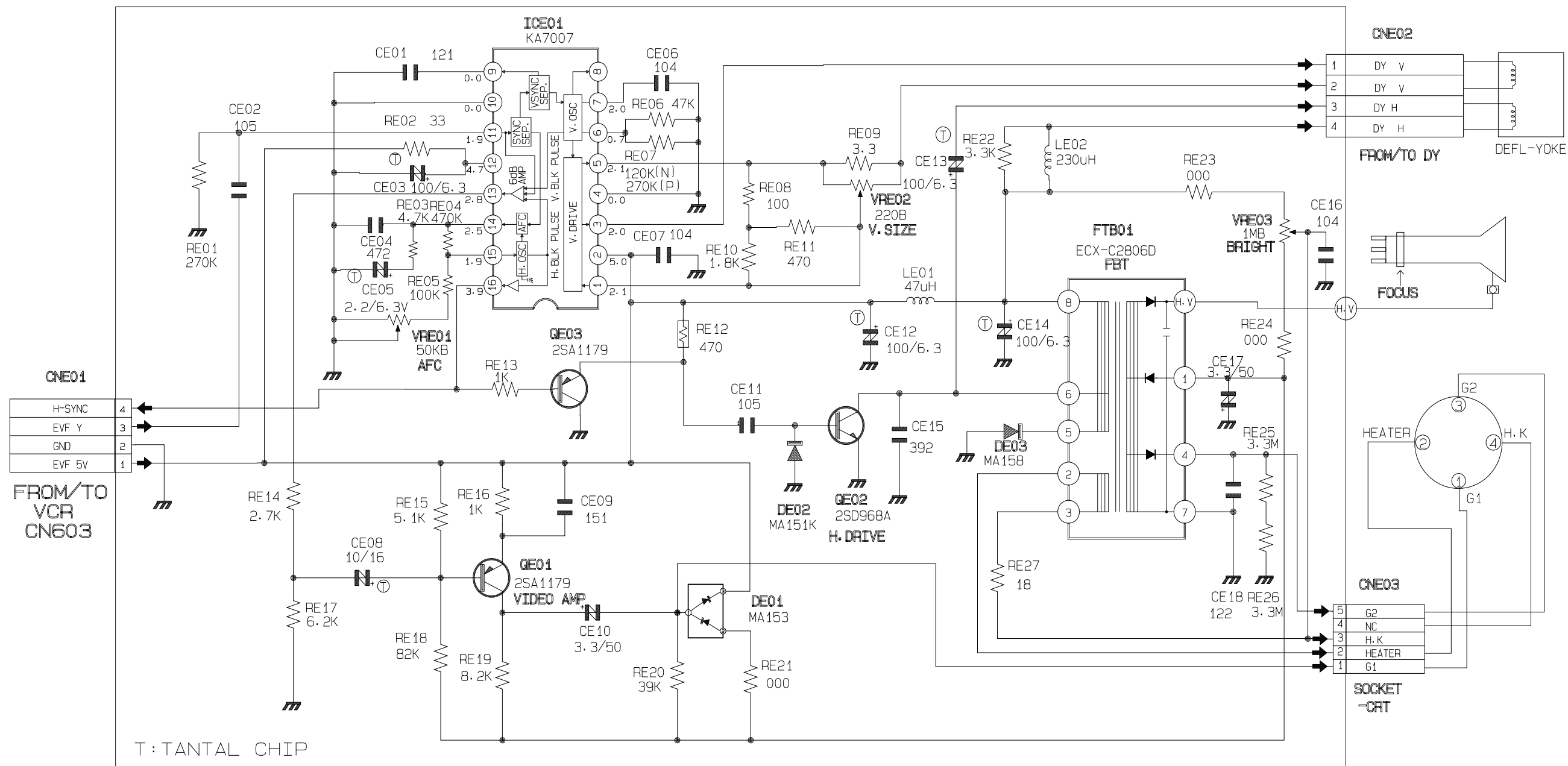

### 11-10 CVF (VP-A21/A23)

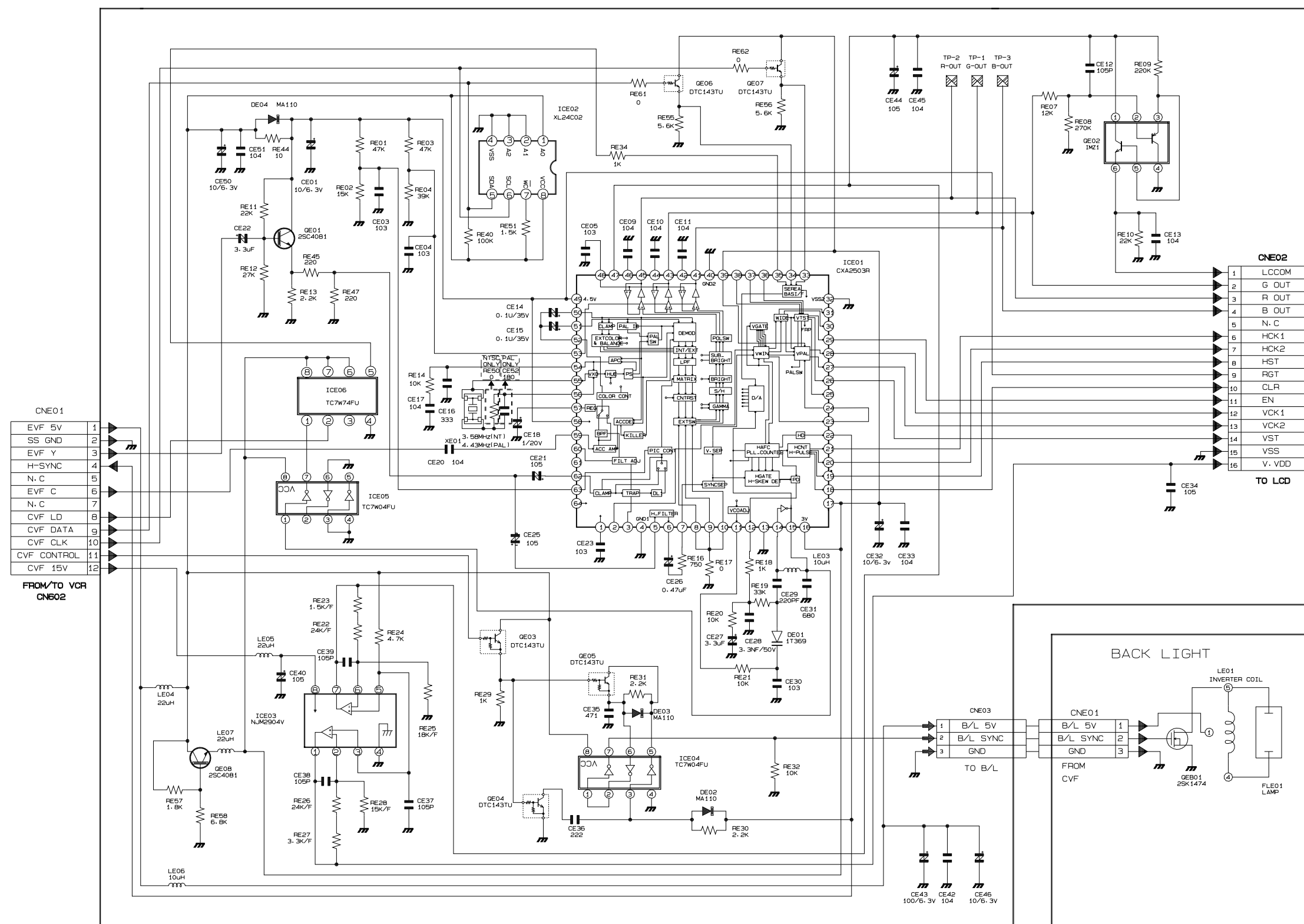

# 11-11 Adaptor

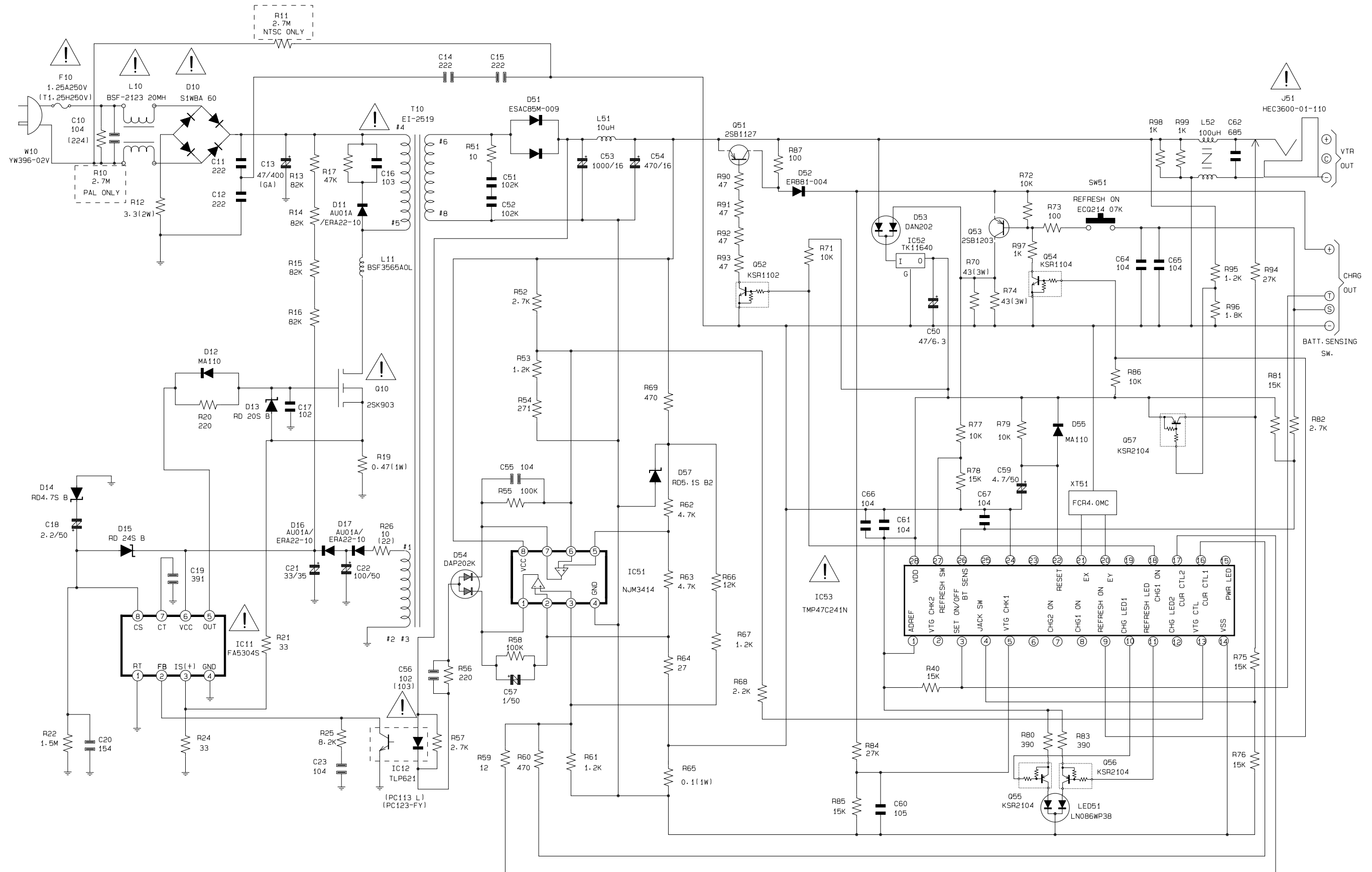

11-12 Front

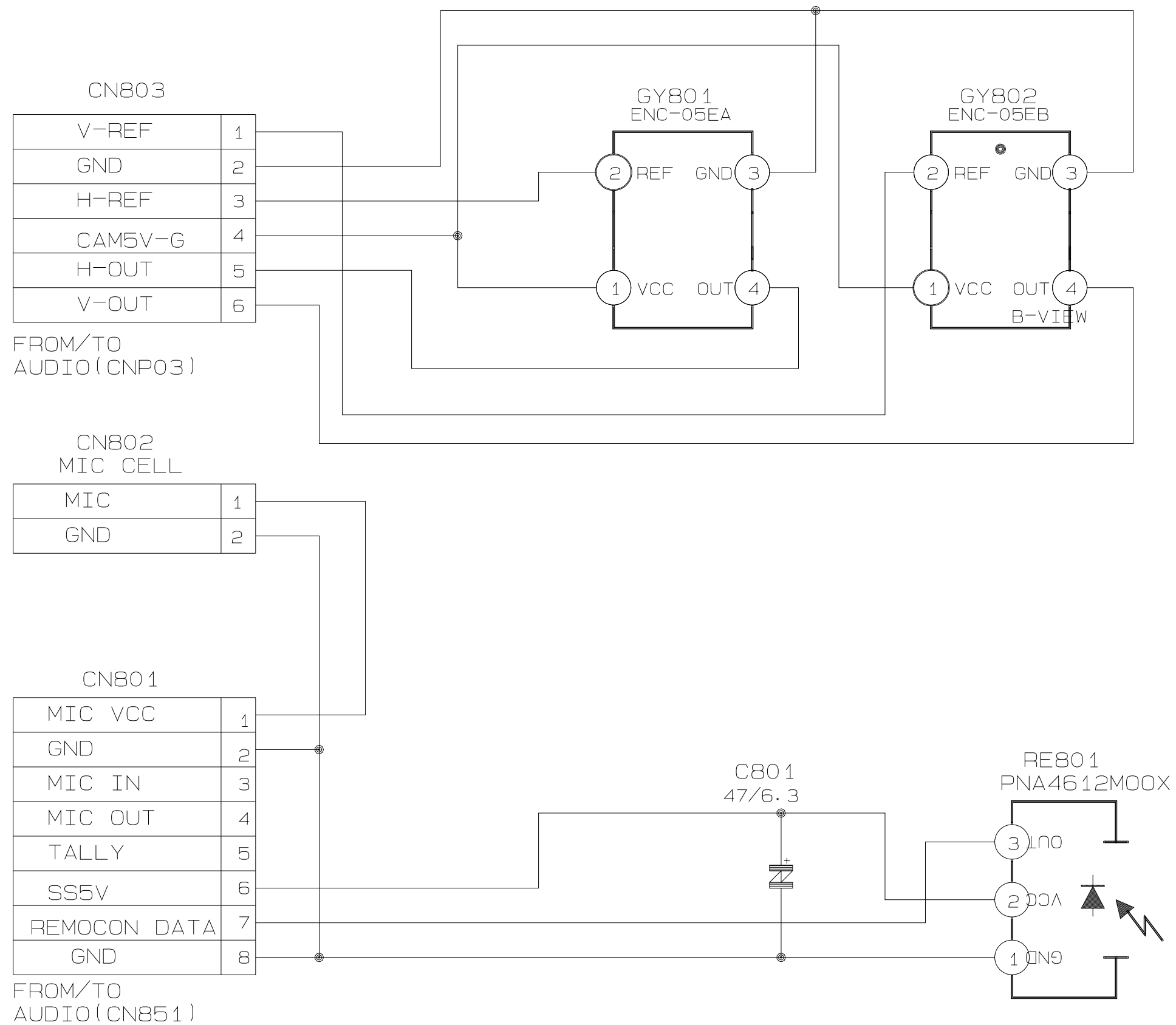

11-2 System Control/Servo(11-4 Page RED) ————— DRUM SPEED SERVO  
- - - - - DRUM PHASE SERVO

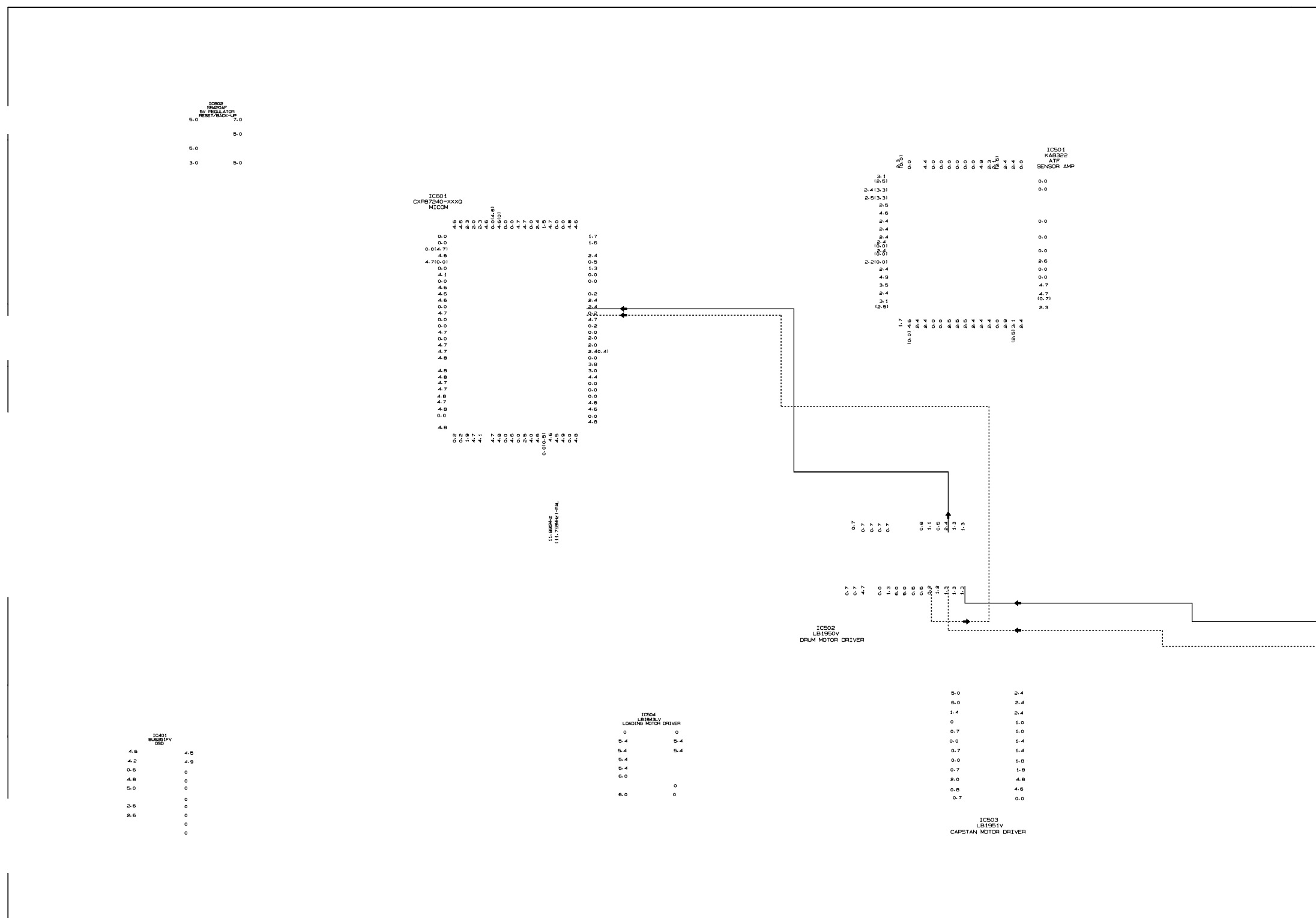

11-2 System Control/Servo (11-4 Page BLUE)

————— CAPSTAN SERVO (SPEED AND PHASE)  
- - - - - CAPSTAN PHASE SERVO

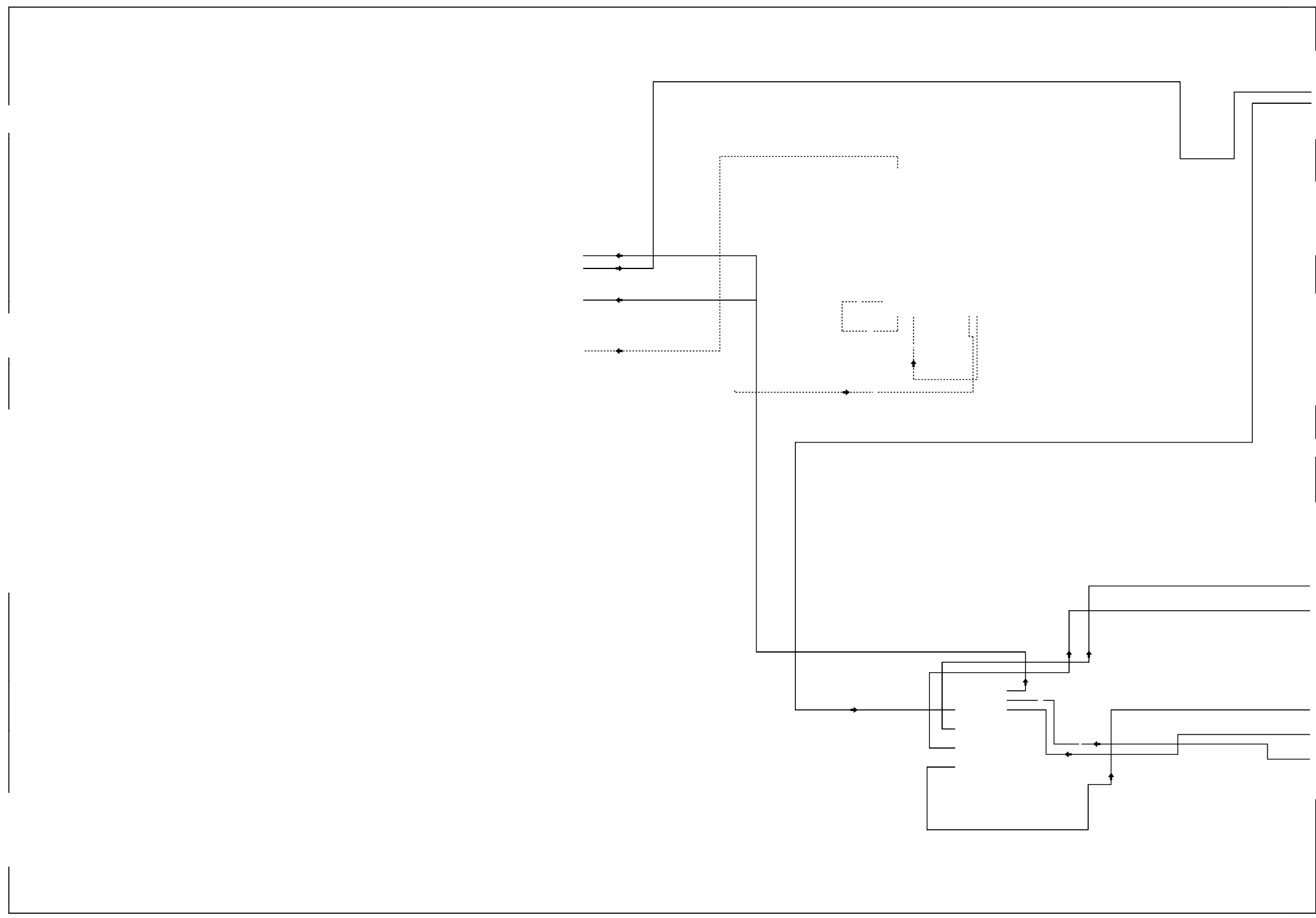

11-2 System Control/Servo (11-4 Page GREEN)

————— DRUM SERVO (SPEED AND PHASE)

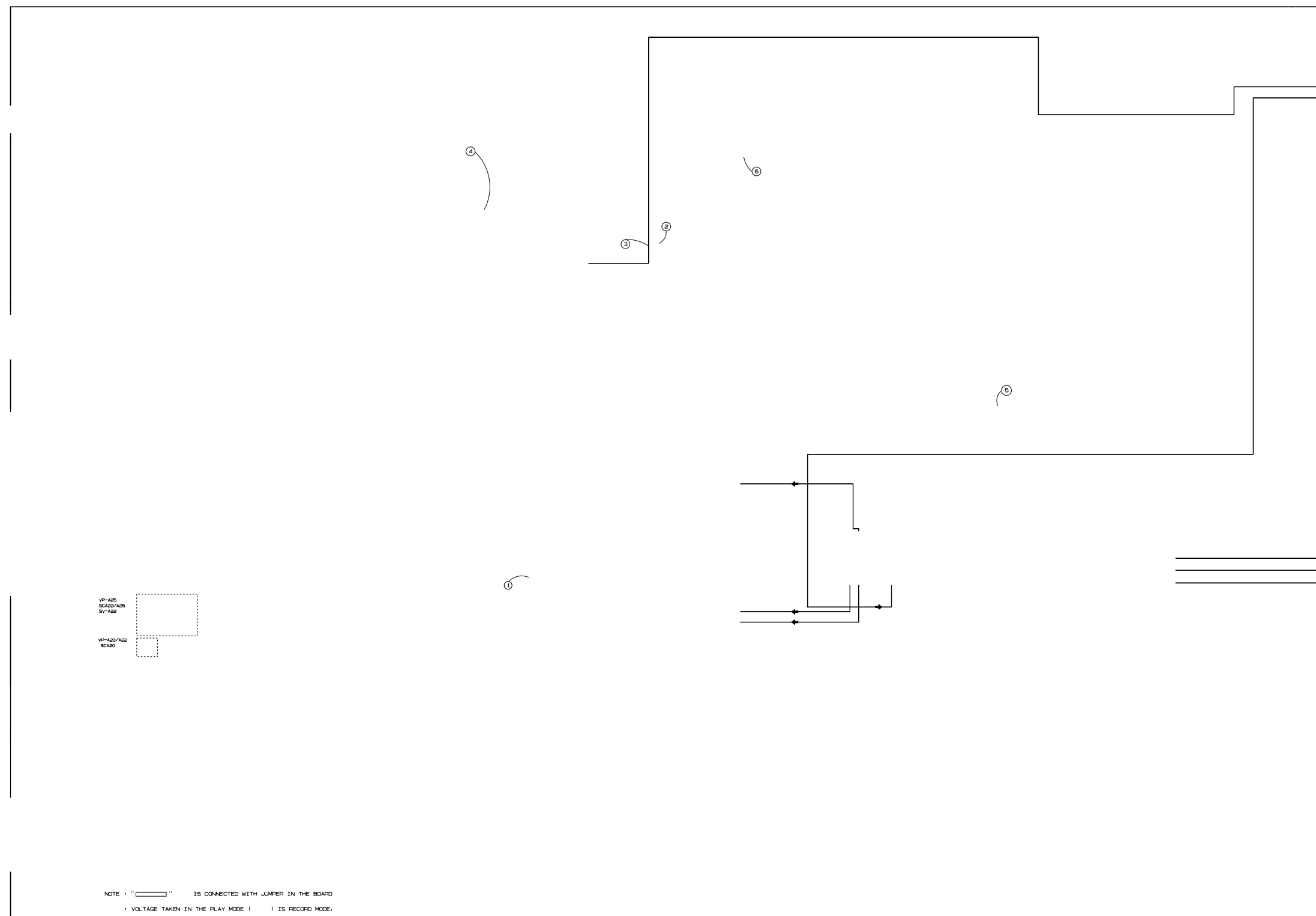

# 11-7 Camera Main (11-9 Page RED)

———— ANALOG SIGNAL  
 - - - - - DIGITAL SIGNAL

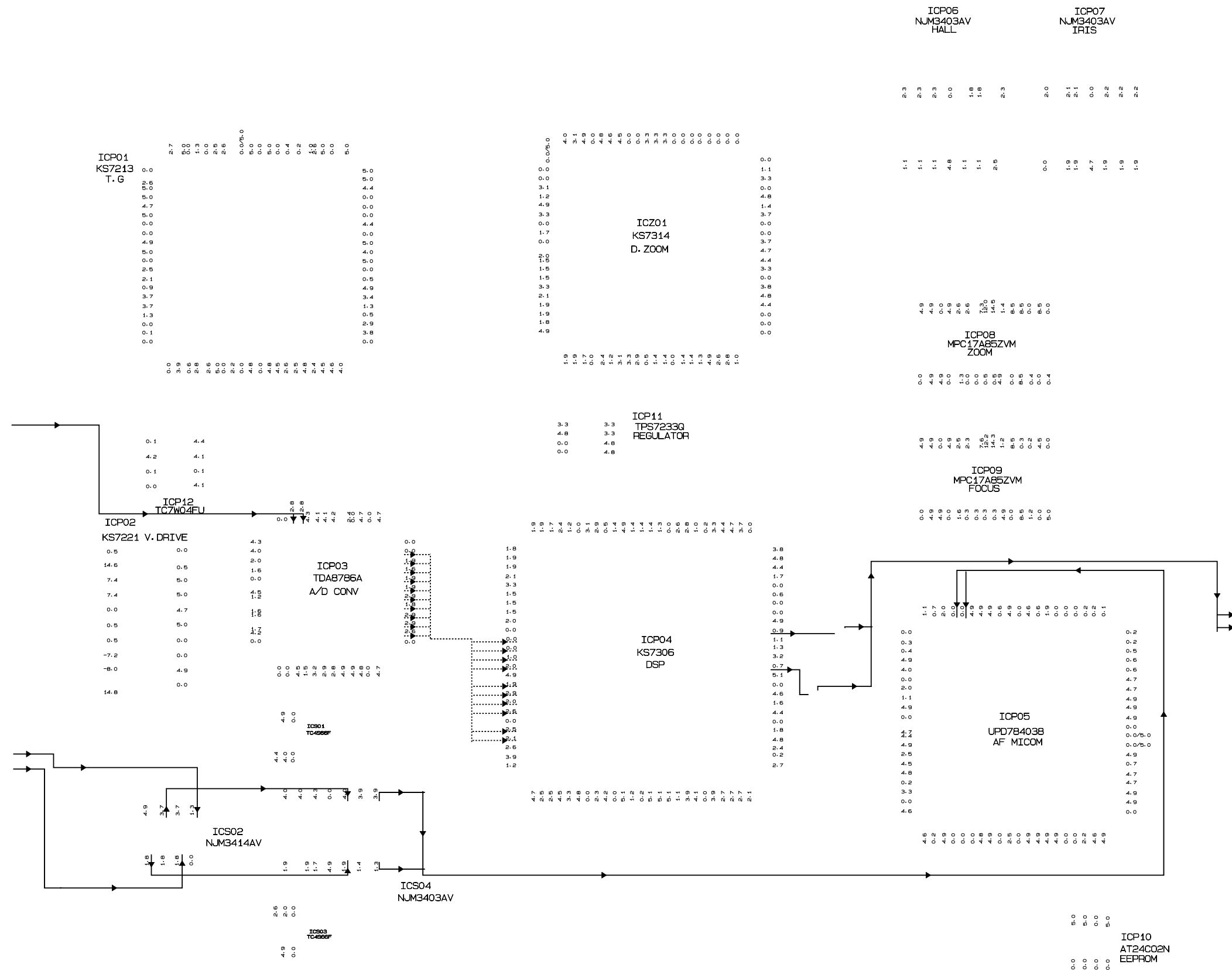
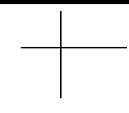
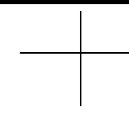

# 11-7 Camera Main (11-9 Page BLUE)

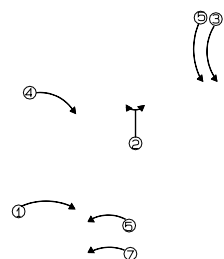
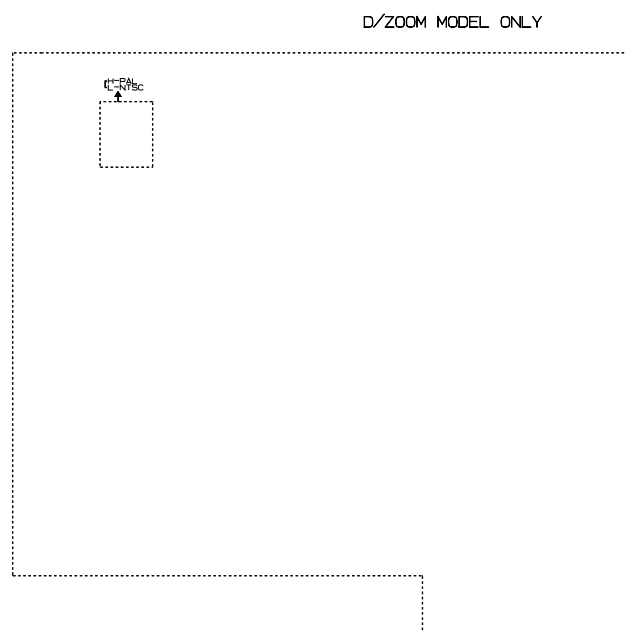
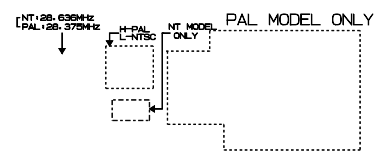
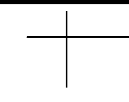

EIS MODEL ONLY

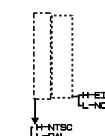

11-9 CCD (11-12 Page RED)

— CCD OUT

ICCO1 [ NTSC : ICX086AK-9  
PAL : ICX087AK-9

ICCO1  
CCD IMAGE SENSOR

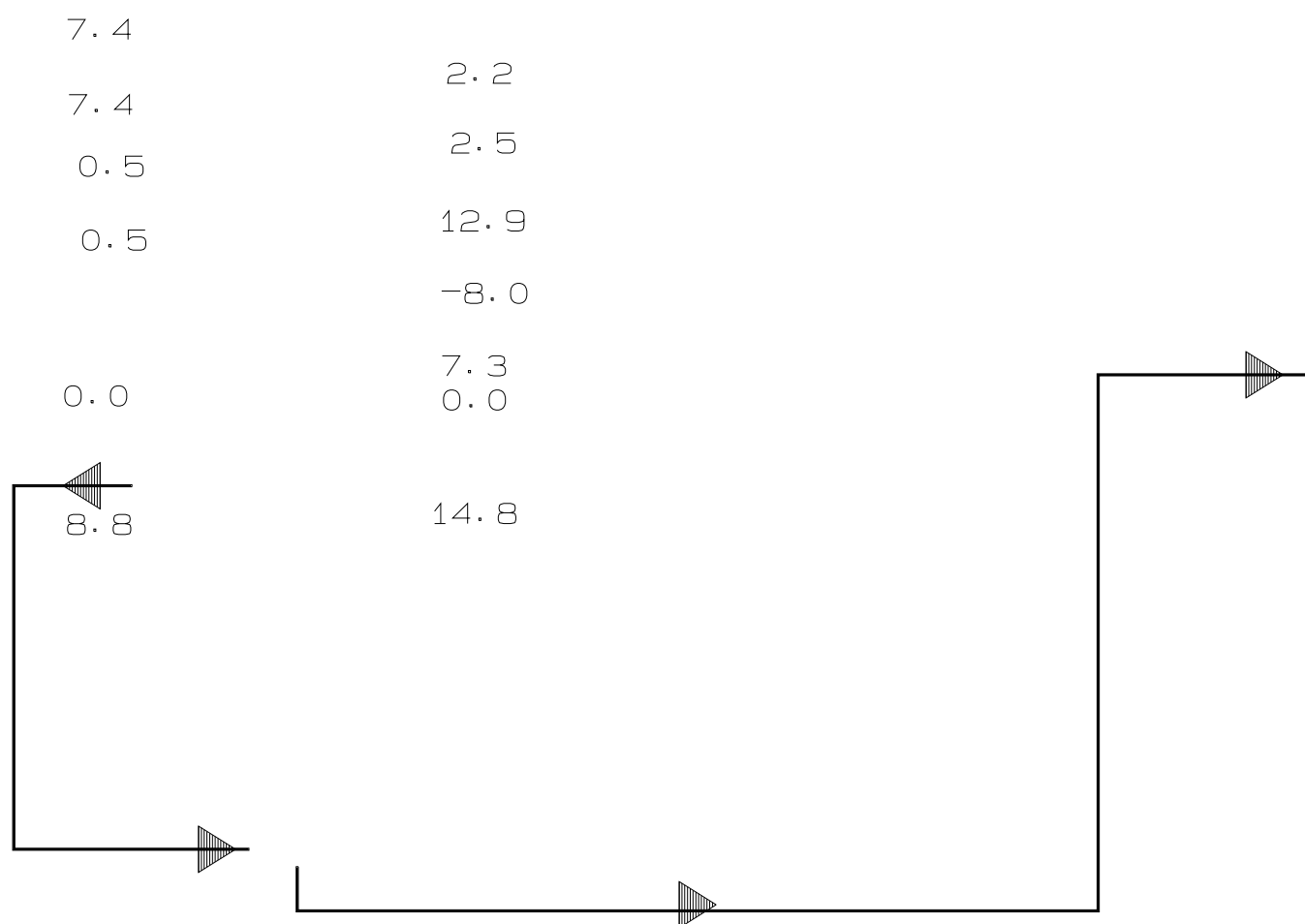

11-9 CCD (11-12 Page BLUE)

