



Macintosh[™]
Reference

Reference

Limited Warranty on Media and Replacement

If you discover physical defects in the manuals distributed with an Apple product or in the media on which a software product is distributed, Apple will replace the media or manuals at no charge to you, provided you return the item to be replaced with proof of purchase to Apple or an authorized Apple dealer during the 12-month period after you purchased the software. In addition, Apple will replace damaged software media and manuals for as long as the software product is included in Apple's Media Exchange Program. While not an upgrade or update method, this program offers additional protection for two years or more from the date of your original purchase. See your authorized Apple dealer for program coverage and details. In some countries the replacement period may be different; check with your authorized Apple dealer.

ALL IMPLIED WARRANTIES ON THE MEDIA AND MANUALS, INCLUDING IMPLIED WARRANTIES OF MERCHANTABILITY AND FITNESS FOR A PARTICULAR PURPOSE, ARE LIMITED IN DURATION TO TWELVE (12) MONTHS FROM THE DATE OF THE ORIGINAL RETAIL PURCHASE OF THIS PRODUCT.

Even though Apple has tested the software and reviewed the documentation, **APPLE MAKES NO WARRANTY OR REPRESENTATION, EITHER EXPRESSED OR IMPLIED, WITH RESPECT TO SOFTWARE, ITS QUALITY, PERFORMANCE, MERCHANTABILITY, OR FITNESS FOR A PARTICULAR PURPOSE. AS A RESULT, THIS SOFTWARE IS SOLD "AS IS," AND YOU, THE PURCHASER, ARE ASSUMING THE ENTIRE RISK AS TO ITS QUALITY AND PERFORMANCE.**

IN NO EVENT WILL APPLE BE LIABLE FOR DIRECT, INDIRECT, SPECIAL, INCIDENTAL, OR CONSEQUENTIAL DAMAGES RESULTING FROM ANY DEFECT IN THE SOFTWARE OR ITS DOCUMENTATION, even if advised of the possibility of such damages. In particular, Apple shall have no liability for any programs or data stored in or used with Apple products, including the costs of recovering such programs or data.

THE WARRANTY AND REMEDIES SET FORTH ABOVE ARE EXCLUSIVE AND IN LIEU OF ALL OTHERS, ORAL OR WRITTEN, EXPRESSED OR IMPLIED. No Apple dealer, agent, or employee is authorized to make any modification, extension, or addition to this warranty.

Some states do not allow the exclusion or limitation of implied warranties or liability for incidental or consequential damages, so the above limitation or exclusion may not apply to you. This warranty gives you specific legal rights, and you may also have other rights which vary from state to state.

Warning

This equipment has been certified to comply with the limits for a Class B computing device in accordance with the specifications of Part 15 of FCC rules. Only peripheral devices (computer input/output devices, terminals, printers, and so on) certified to comply with Class B limits may be attached to this computer.

Operation with noncertified peripheral devices is likely to result in interference to radio and television reception.

DOC Class B Compliance This digital apparatus does not exceed the Class B limits for radio noise emissions from digital apparatus set out in the radio interference regulations of the Canadian Department of Communications.

Observation des normes—Classe B Le présent appareil numérique n'émet pas de bruits radioélectriques dépassant les limites applicables aux appareils numériques de la Classe B prescrites dans les règlements sur le brouillage radioélectrique édictés par le Ministère des Communications du Canada.



Macintosh™
Reference

Reference

Apple Computer, Inc.

This manual and the software described in it are copyrighted, with all rights reserved. Under the copyright laws, this manual or the software may not be copied, in whole or part, without written consent of Apple, except in the normal use of the software or to make a backup copy of the software. The same proprietary and copyright notices must be affixed to any permitted copies as were affixed to the original. This exception does not allow copies to be made for others, whether or not sold, but all of the material purchased (with all backup copies) may be sold, given, or loaned to another person. Under the law, copying includes translating into another language or format.

You may use the software on any computer owned by you, but extra copies cannot be made for this purpose.

The Apple logo is a trademark of Apple Computer, Inc. Use of the "keyboard" Apple logo (Option-Shift-K) for commercial purposes without the prior written consent of Apple may constitute trademark infringement and unfair competition in violation of federal and state laws.

© Apple Computer, Inc., 1990
20525 Mariani Avenue
Cupertino, CA 95014-6299
(408) 996-1010

APDA, Apple, Apple Desktop Bus, the Apple logo, AppleLink, AppleShare, AppleTalk, Apple IIgs, A/UX, CloseView, Disk First Aid, EtherTalk, Finder, HyperCard, ImageWriter, LaserWriter, LocalTalk, Macintosh, MacroMaker, MultiFinder, ProDOS, QuickDraw, and SuperDrive are trademarks of Apple Computer, Inc

Apple *Care* is a registered service mark of Apple Computer, Inc.

Adobe and PostScript are registered trademarks, and Adobe Garamond, Adobe Separator, and Illustrator 88 are trademarks, of Adobe Systems Incorporated.

CompuServe is a registered service mark of CompuServe, Inc.

Eveready is a registered trademark of Eveready Battery Company, Inc.

FileMaker, MacDraw, MacPaint, MacProject, and MacWrite are registered trademarks of Claris Corporation.

Fourth Dimension is a registered trademark of Acius, Inc.

FreeHand is a trademark of Aldus Corporation.

FullPaint is a trademark of Ashton-Tate Corporation.

ITC Zapf Dingbats is a registered trademark of International Typeface Corporation.

Linotronic is a registered trademark of Linotype Co.

MicroPhone is a trademark of Software Ventures Corporation.

Microsoft Word and MS-DOS are registered trademarks of Microsoft Corporation.

NuBus is a trademark of Texas Instruments.

QuarkXPress is a trademark of Quark, Inc.

Studio/8 is a registered trademark of Electronic Arts.

SuperPaint is a registered trademark of Silicon Beach Software, Inc.

WriteNow is a trademark of T/Maker Company.

Mention of third-party products is for informational purposes only and constitutes neither an endorsement nor a recommendation. Apple assumes no responsibility with respect to the performance or use of these products.

	Radio and television interference	xiv
Preface	About This Book	xv
	What you should know to use this book	xvi
	How to use this book	xvi
	Complete information for each task	xvi
	Two ways to locate tasks	xvii
	Review of Macintosh fundamentals	xvii
	Summaries for expanding your Macintosh system	xvii
	A note about illustrations	xvii
	Some conventions used in this book	xviii
	About the other learning materials	xix
Chapter 1	Standard Macintosh Operations	1
	Using the mouse	2
	Pointing	3
	Clicking	4
	Double-clicking	5
	Dragging an icon	5
	Selecting an icon or other object	6
	Selecting multiple icons or objects in one area	7
	Selecting multiple objects in separate areas	8

Working on the desktop	9
Opening an icon	9
Moving a window	10
Resizing a window	11
Enlarging a window to full size	12
Making a window active	12
Closing a window	13
Discarding an icon	14
Viewing the content of a window	16
Scrolling through a window	16
Scrolling to a specific part of a window	18
Scrolling the length or width of a window	19
Using menus	20
Pulling down a menu	21
Choosing a menu command	21
Using a submenu	23
Using a pop-up menu	24
Responding to messages on the screen	26
Using a dialog box	27
Using alert boxes	28
Basic editing on the desktop	29
Changing all of an icon's name	29
Selecting part of the text in an icon's name	30
Replacing selected text in an icon's name	32
Deleting selected text from an icon's name	33
Inserting text in an icon's name	34
Using the Control Panel	35
Control Panel actions	36
Opening the Control Panel	36
Changing sections of the Control Panel	37
Changing settings in the Control Panel	38
Using the Chooser	39
Opening the Chooser	39
Selecting a printer or other device in the Chooser	40
Adjusting Chooser settings	41
Using special keys and indicators on the keyboard	42

Turning the Macintosh on and off	43
Power switch locations	43
Turning on a compact Macintosh model	44
Turning on a modular Macintosh model	45
Turning off the Macintosh	45

Chapter 2 Starting Up 47

Preparing the Macintosh hardware	48
Preparing your system software	48
Checking system software that is already installed	49
Installing system software	51
Creating a customized system	56
Installing system software on a Macintosh with only one disk drive	60
Making an extra startup disk	60
Creating a small system	62
Updating to a new version of system software	63
Installing 32-Bit QuickDraw for enhanced color images	64
Starting Up the Macintosh	65
Specifying items to be opened at startup	65
Selecting one startup program or document	66
Selecting multiple startup items	67

Chapter 3 Working With Application Programs 71

Preparing to use a program for your work	72
Installing a program	72
Starting a program	73
Creating a new document in a program	74
Opening an existing document in a program	75
Opening a document on the desktop	76
Editing documents	76
Editing text	77
Copying text and images	77
Inserting copied text and images within a document	78

Copying text and images between documents in different programs	79
Deleting text and images	82
Canceling an editing action	83
Saving documents	84
Saving a new document	85
Saving a revised document	86
Saving a document under a new name	87
Saving a second copy of a document under the same name on a single disk	88
Saving a document onto a different disk	90
Saving text and images in the Scrapbook for easy access	91
Knowing where you are on the Macintosh	94
Returning to the desktop from a program	96
Managing multiple programs using MultiFinder	97
Turning MultiFinder on	98
Switching programs or desk accessories with MultiFinder	100
Starting a new program when using MultiFinder	101
Managing system memory	102
MultiFinder's memory requirements	103
Checking the amount of RAM in your Macintosh	103
Checking the RAM available for programs in MultiFinder	104
Clearing system memory for efficient operation	104
Changing the memory allocation for a program	105
Adjusting the RAM cache	106
Ending a work session	109
Quitting an application program	109
Backing up the session's work	110
Shutting down the computer	110

Chapter 4 Printing Documents 113

- Getting ready to print 113
 - Placing printer drivers in the System Folder 114
 - Choosing a printer 116
 - Selecting Page Setup options 118
- Printing your work 120
 - Printing from within a program 122
 - Printing from the desktop 123
 - Printing a directory of disk or folder contents 124
- Color or gray-scale printing 126
 - Installing the LaserWriter drivers for color or gray-scale printing 126
 - Printing color or gray-scale documents 128
- Printing while using the computer for other work 130
 - Using background printing 130
 - Managing printing jobs 131

Chapter 5 Organizing Documents 135

- Handling documents 136
 - Moving a document 136
 - Copying a document onto another disk 137
 - Copying a document on the same disk 138
 - Renaming a document 139
- Using folders to organize your work 140
 - Creating and naming folders 141
 - Placing documents inside folders 142
 - Nesting folders 143
- Locating documents and folders 144
 - Finding documents by name or partial name 144
 - Moving quickly through levels of folders when using a program 146
 - Moving to a new folder level with a pop-up menu 148
 - Putting away items on the desktop 149

- Getting directory information 150
 - Displaying documents by name, size, date, kind, or color of icon 150
 - Getting information about an icon 151
 - Getting information about a program 153

Chapter 6 Managing Disks and Disk Drives 155

- Using floppy disks 156
 - Disk capacities 156
 - High-density disks and SuperDrive 157
 - Inserting a disk 158
 - Ejecting a disk from the desktop 159
 - Ejecting a disk from within a program 160
 - Initializing and naming a disk 161
 - Erasing a disk 163
 - Renaming a disk 164
 - Backing up a disk 165
- Using a hard disk 166
 - Hard disk precautions 167
 - Initializing and naming a hard disk for the first time 168
 - Partitioning a hard disk 170
 - Erasing a hard disk 174
 - Renaming a hard disk 175
 - Backing up a hard disk 175
- Startup disk sequence 176
 - The scanning order for a startup disk 176
 - Designating a hard disk as the startup device 177
- Protecting information on a disk 179
 - Locking a floppy disk 179
 - Locking documents 180

Chapter 7 Using the Macintosh on a Computer Network 183

- Adding the Macintosh to a network 183
 - Connecting to an existing LocalTalk network 184
 - Preparing the Macintosh system software for networking 187
 - Changing from one network to another network 190
- Using a printer on the network 192
 - Choosing a network printer 193
 - Printing your work on a network printer 194
 - Using a print server 195
- Using an AppleShare file server 196
 - Gaining access to an AppleShare file server 196
 - Storing and retrieving information on an AppleShare file server 200
 - Creating private files on a file server 200
- Connecting to another computer via modem 201

Chapter 8 Personalizing Your Macintosh Work Space 203

- Adjusting mouse operation 204
 - Setting the correlation between mouse and pointer movement 204
 - Setting the double-clicking speed 206
- Adjusting keyboard operation 208
 - Setting the keys' repeat rate 209
 - Setting the delay before keys repeat 210
- Adjusting sound and volume 211
 - Setting the speaker volume 211
 - Setting the alert sound 213
- Setting time and date 214
 - Changing the time 215
 - Changing the date 217
 - Setting an alert time with the Alarm Clock 218
- Changing the look of the desktop 222
 - Changing the pattern displayed on the desktop 223
 - Adjusting the blinking of a selected menu item 225

Adjusting the blinking of the insertion point	226
Indicating the relative positions of multiple monitors	227
Designating a main monitor	231
Adjusting screen brightness	234
Designating colors or shades of gray	235
Specifying the number of colors or shades of gray	235
Changing the highlight color	238
Changing the colors or shades of gray in the desktop pattern	242
Designating the color of icons	244
Moving fonts and desk accessories	246
Installing a font	247
Removing a font	251
Installing a desk accessory	253
Removing a desk accessory	258
Creating a file of desk accessories or fonts	260

Chapter 9 Expanding Your Macintosh System 265

Connecting SCSI devices	265
Setting the SCSI device number	266
Daisy-chaining SCSI devices	267
Connecting non-SCSI devices	269
Connecting a printer	269
Connecting a modem	271
Connecting an external floppy disk drive	272
Connecting Apple Desktop Bus devices	273
Apple Desktop Bus device connected to a Macintosh	274
Apple Desktop Bus device daisy-chained to another ADB device	275
Connecting audio devices	276
Adding an additional monitor	276
Connecting a monitor to a built-in video port	277
Connecting a monitor to a video card	279
Positioning monitors	281

Installing expansion cards	281
Using multiple expansion cards	285
Power requirements and limitations	285
Assuring adequate ventilation	286
Installing cards in a special slot	286
Expanding memory on the main circuit board	287

Chapter 10 Macintosh Maintenance and Troubleshooting 289

Safety and general care	290
All system components	290
Monitor	291
Keyboard	291
Floppy disk drives	292
Floppy disks	292
Operating environment	293
Cleaning system components	294
Computer and peripheral-device cases	294
Monitor	294
Mouse	294
Testing and repairing a disk	297
Using Disk First Aid to test or repair a floppy disk or a hard disk	297
Using HD SC Setup to test a SCSI hard disk	299
Changing the clock battery	300
Macintosh Plus	300
Other Macintosh models	301
Troubleshooting	302
Avoiding data loss or damage	302
Check regularly for viruses	302
Computer operation	304
The computer is turned on but the screen is dark	304
When you insert a disk, the screen is bright but the desktop doesn't appear	304
The mouse moves but the pointer doesn't move	306
Typing on the keyboard produces nothing on the screen	306

You can't eject a floppy disk	308
You can't start up from a hard disk or see its icon	309
A dialog box with a bomb appears	309
The pointer suddenly "freezes" on the screen	311
Printer operation	312
You give the command to print a document and the printer doesn't respond	312
You print a document on a network printer and it causes the printer to restart or to display an error message	313
General tips	313
Start over	313
Make certain that all parts of the system software are from the same version	314
Make certain that your programs are in good working order	314
Create free space on the startup disk	315
Take your time	316
Rebuild your desktop once a year	317
Back up your work and your programs frequently	317
Service and support	318

Appendix A Keyboards and Character Sets 321

Keyboard layouts	321
Macintosh Classic/Macintosh LC keyboard	322
Apple Keyboard	324
Apple Extended keyboard	326
Optional characters	328
Viweing optional characters with Key Caps	328
Typing accented characters	330

Appendix B MacroMaker Command Files 331

Installing MacroMaker	332
Creating macros with MacroMaker	333

Appendix C	Exchanging Disks and Files with MS-DOS Computers	336
	Using Apple File Exchange for MS-DOS disks and files	337
	Initializing an MS-DOS disk in a SuperDrive	337
	Converting files to and from MS-DOS format	339
	Other file-conversion options	344
	More information about Apple File Exchange Options	345
	Converting Apple II files with Apple File Exchange	345
Appendix D	Special Aids for Using the Mouse, Keyboard, and Screen	346
	Keyboard and mouse assistance with Easy Access	347
	Easier keyboard use with Sticky Keys	347
	Easier mouse use with Mouse Keys	348
	Easier screen viewing with CloseView	350
Appendix E	Where to Get More Information About Your Macintosh	353
	Macintosh user groups	354
	Technical information	354
	Apple Technical Library	355
	Apple Communications Library	355
	APDA	355
	Assistance for hardware and software developers	356
Appendix F	Glossary	357
	Index	373

Radio and television interference

The equipment described in this manual generates and uses radio-frequency energy. If it is not installed and used properly—that is, in strict accordance with Apple’s instructions—it may cause interference with radio and television reception.

This equipment has been tested and complies with the limits for a Class B computing device in accordance with the specifications of Part 15 of FCC rules. These specifications are designed to provide reasonable protection against such interference in a residential installation. However, there is no guarantee that the interference will not occur in a particular installation.

You can determine whether your computer is causing interference by turning it off. If the interference stops, it was probably caused by the computer or one of the peripheral devices.

If your computer system does cause interference to radio or television reception, try to correct the interference by using one or more of the following measures:

- Turn the television or radio antenna until the interference stops.
- Move the computer to one side or the other of the television or radio.
- Move the computer farther away from the television or radio.
- Plug the computer into an outlet that is on a different circuit from the television or radio. (That is, make certain the computer and the television or radio are on circuits controlled by different circuit breakers or fuses.)
- Consider installing a rooftop television antenna with a coaxial cable lead-in between the antenna and the television.

If necessary, consult your authorized Apple dealer or an experienced radio/television technician for additional suggestions. You may find helpful the following booklet, prepared by the Federal Communications Commission: “*How to Identify and Resolve Radio-TV Interference Problems?*” (stock number 004-000-00345-4). This booklet is available from the U.S. Government Printing Office, Washington, DC 20402.

- △ **Important:** This product was tested for FCC compliance under conditions that included the use of shielded cables and connectors between system components. It is important that you use shielded cables and connectors to reduce the possibility of causing interference to radios, television sets, and other electronic devices. For Apple peripheral devices, you can obtain the proper shielded cables from your authorized Apple dealer. For non-Apple peripheral devices, contact the manufacturer or dealer for assistance. △

About This Book

The *Macintosh Reference* is your sourcebook for using the Macintosh™ computer. This manual is a “working reference”—that is, it provides step-by-step instructions for all the tasks you are likely to perform with the computer.

No matter which Macintosh model you use, the primary operations and tasks you perform with the computer work the same way, and all of them are covered in this book.

One procedure not covered here, however, is the setup of your Macintosh system. Consult the booklet *Setting Up Your Macintosh* for the instructions you need to set up your computer hardware.

What you should know to use this book

You can use the *Macintosh Reference* most efficiently if you are already familiar with the Macintosh, because this book's instructions are concise and specific. If you're new to the Macintosh (or to using any computer), it's a good idea to go through the tutorial book, *Getting Started With Your Macintosh*, or the training disk, *Macintosh Basics*, or both.

But even if you're not familiar with the Macintosh, this reference book will give you the information you need to perform a wide variety of tasks. By simply following the prominently numbered steps, you can work your way through any task—whether it's new to you or a task you've done before for which you need a quick review.

How to use this book

As noted previously, the *Macintosh Reference* is organized according to a variety of tasks that you perform when working with your Macintosh.

Complete information for each task

Each task is presented as a set of steps. Each step consists of boldface text and an illustration, side by side; the steps are numbered with large numerals.

When you turn to a task in this book, the numbered steps provide the complete instructions you need to accomplish that task.

Two ways to locate tasks

The tasks in this book are grouped together in major categories of the work you do with the Macintosh—creating and editing documents, managing files, printing documents, working with disks, and so forth.

Two parts of the book will help you quickly locate the tasks you want to do: (1) the table of contents, which lists the major categories of information and the names of all tasks, and (2) the comprehensive index, which lists each task under several different terms that you might think of in relation to that task.

Review of Macintosh fundamentals

Chapter 1, “Standard Macintosh Operations,” provides a brief review of the the fundamentals—using the mouse, working on the desktop, using menus, basic editing, and so on.

If your Macintosh experience is limited, you can use Chapter 1 as a “refresher course” any time you need its help.

Summaries for expanding your Macintosh system

Chapter 7, “Using the Macintosh on a Computer Network,” and Chapter 9, “Expanding Your Macintosh System,” provide summaries of the procedures involved in adding your computer to a network and adding new components to your computer system. The instructions in these chapters are intended for quick review, and should be used in combination with the documentation for the components you’re adding to your system or network.

A note about illustrations

Some illustrations of the Macintosh screen include lists of options, such as the choices available for your Macintosh model when you install the system software or partition a hard disk. The lists reproduced in this book’s illustrations may differ from those that appear on your screen when you perform a task, because the options available vary from one model to another.

Some conventions used in this book

The primary information in this book is presented as step-by-step instructions for each task. All steps are numbered, and all actions are described in **boldface** type.

The Macintosh lets you do many actions in more than one way, such as choosing a command from a menu or typing a combination of keys on the keyboard to initiate the command. This book provides step-by-step instructions for one method and advises you of other methods.

❖ *Another way to perform this action:* Check paragraphs that begin with this symbol (❖) for alternative methods of taking an action. ❖

Because many tasks are related to other tasks, this book contains numerous cross-references. These cross-references always appear at the end of the related section, and they are preceded by their own typographic symbol, an arrowhead. Here is a sample.

➤ *See also:* • “Changing the Highlight Color” in Chapter 8

About the other learning materials

The *Macintosh Reference* is part of the learning materials provided with your Macintosh. The other books and disks in this set include

- the booklet *Setting Up Your Macintosh*, which provides instructions for hardware setup for the Macintosh model you have.
- the tutorial book *Getting Started With Your Macintosh*, which provides instructions for novice users and explains many of the concepts associated with using a Macintosh computer.
- the training disk *Macintosh Basics*, which provides hands-on instruction and practice for new users of the Macintosh. The training disk and the tutorial book cover much of the same material; you can use one or both, according to your preferred style of learning.
- the booklet *Special Options and Technical Information* for your Macintosh model. This booklet contains details about special features of that model and instructions for using those features, as well as the technical specifications for that model of the Macintosh.
- one or more additional training or information disks may be included with the learning materials, depending on the Macintosh model.
- the learning materials for HyperCard™, consisting of a series of books and disks.

You can choose from these learning materials as your experience and information needs require.



Standard Macintosh Operations

The Apple™ Macintosh™ computer is designed for ease of use and learning. It presents you with a simulated desktop on your screen, where you can see and manipulate *icons*—graphic depictions of documents, disks, file folders, and the other parts of your system and the information you work with. (See Figure 1-1.)

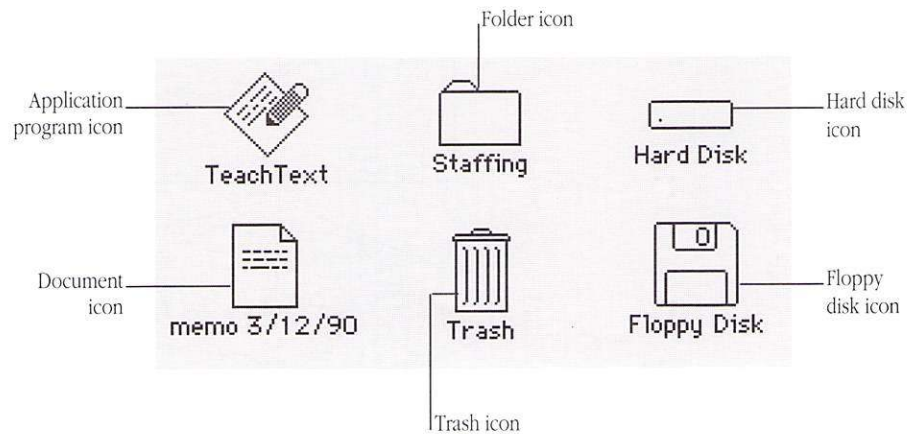

Figure 1-1 Examples of Macintosh icons

Most important, you use about two dozen simple operations to work with your Macintosh, and these operations are the same regardless of the program you're using or the task you're performing.

This chapter introduces the standard Macintosh operations and provides brief, illustrated instructions for performing each one. If you are new to the Macintosh, you will probably want to use the tutorial, *Getting Started With Your Macintosh*, or the training disk, *Macintosh Basics*, before reading this chapter. If you are familiar with the Macintosh, you may want to review this chapter before beginning your work.

Using the mouse

You use the *mouse*—a kind of pointing device—to initiate most operations on the Macintosh. When you move the mouse on your desk, a corresponding *pointer*—such as the arrow pointer or I-beam pointer—makes the same movement on the screen. (See Figure 1-2.)

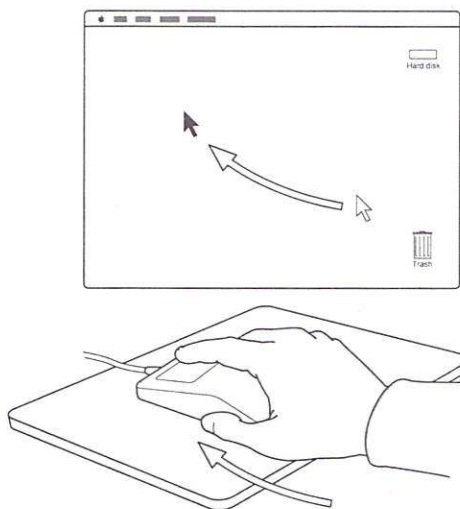

Figure 1-2 Mouse and pointer movement

To initiate an action with the mouse, you place the pointer where you want the action to take place, then press and release the mouse button (the mechanical button near the top of the mouse). This action is called *clicking*. (See Figure 1-3.)

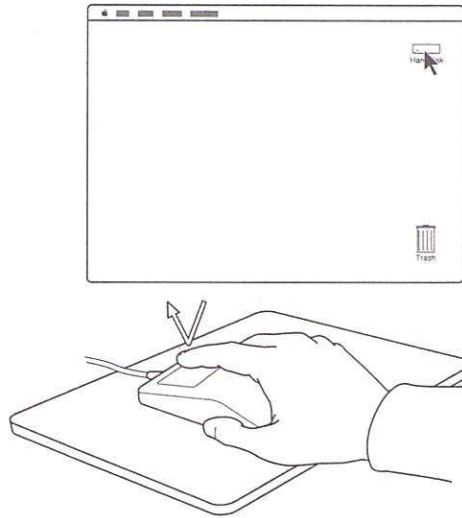
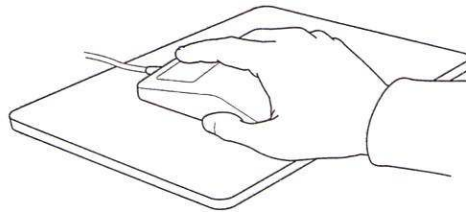

Figure 1-3 Initiating an action with the mouse

Pointing Pointing is simply moving the pointer onto an object or area on the screen.



1 To point, first grasp the mouse and slide it across the table top, as you watch the pointer on the screen.

The pointer's movement corresponds to that of the mouse.

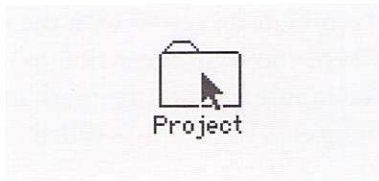

2 Continue moving the mouse until the tip of the pointer is on the item you want.

If you run out of room, you can pick up the mouse and place it at another spot. The pointer on the screen will not move while the mouse is off the pad or other surface.

Clicking *Clicking* initiates an action at the pointer's location.

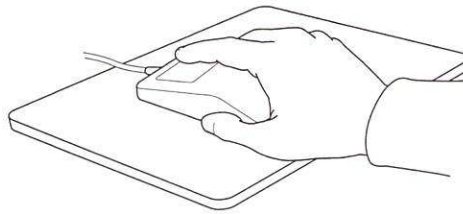

1 To click, first point to an object on the screen by moving the mouse.

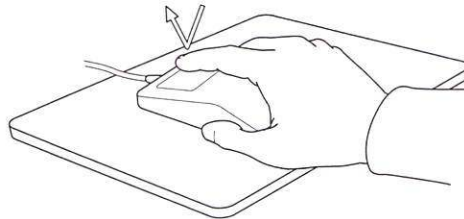

2 Without moving the mouse, quickly press and release the mouse button with your index finger.

Double-clicking *Double-clicking* is a way to display the contents of an icon or document or to start an application by opening a window for it.

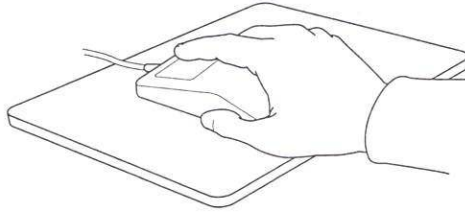

1 To double-click, first point to an object on the screen by moving the mouse.

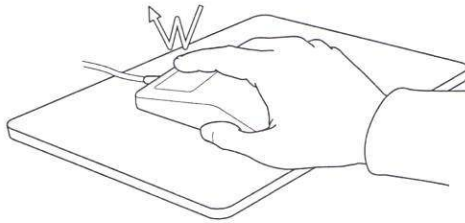

2 Without moving the mouse, press and release the mouse button twice in rapid succession.

Dragging an icon *Dragging* allows you to move an icon on the screen as you move the mouse.

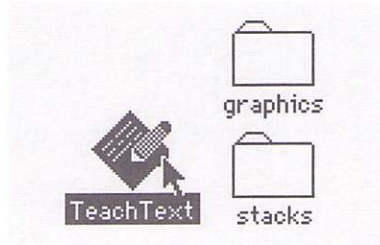

1 To drag an icon, first point to the icon you want to move and press and hold the mouse button.

The object becomes *highlighted* when you press the mouse button; that is, its appearance changes, usually from outline form to solid black (or other color).

An outline of the icon being dragged shows its movement.

The highlighted icon stays in its original position while you drag.

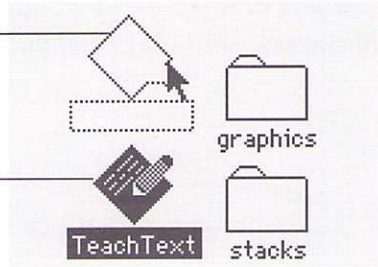

The highlighted object jumps to a new position when you release the mouse button.

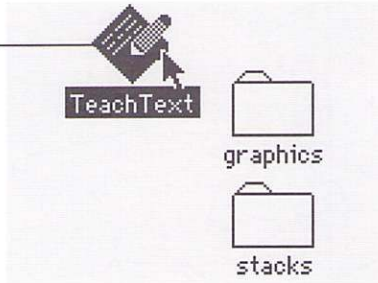

2 Move the mouse while continuing to hold down the button.

An outline of the icon moves with the pointer, indicating the location of the icon as you drag.

3 Release the mouse button when the move is complete.

The object remains highlighted when you release the button.

Selecting an icon or other object

Selecting designates an object for action. When selected, the object appears *highlighted*.

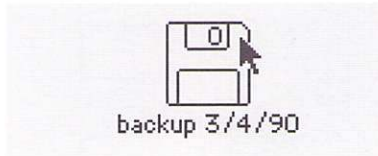

1 To select an object, first point to the object you want to select.

2 Click the object.

When you press the mouse button, the object becomes highlighted to show that it is selected.

➤ *See also:* • “Changing the Highlight Color” in Chapter 8

Selecting multiple icons or objects in one area

You can drag the pointer to select a group of icons or other objects that are located in one area of the screen. A dotted rectangle indicates the area covered as you drag.

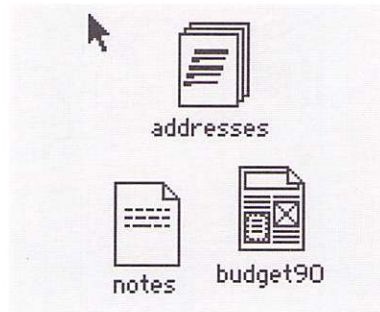

1 To select multiple objects in one area, place the pointer near one edge of the group of objects, then drag diagonally over them.

A dashed outline encloses the objects as you drag across them. Dragging diagonally from one corner of the area is most efficient.

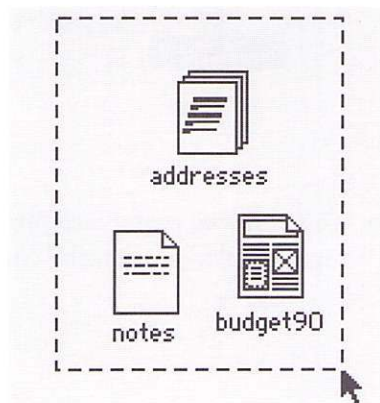

2 Release the mouse button when the objects you want to select are completely or partially inside the dashed outline.

When you release the mouse button, the selected objects become highlighted.

❖ *Dragging is also used for:* (1) selecting a group of items together in a list; (2) selecting text when editing; and (3) choosing a command from a menu. ❖

➤ *See also:*

- “Basic Editing on the Desktop” in this chapter
- “Using Menus” in this chapter

Selecting multiple objects in separate areas

You can select objects that are not near each other by clicking each one while holding down the Shift key (called *Shift-clicking*).

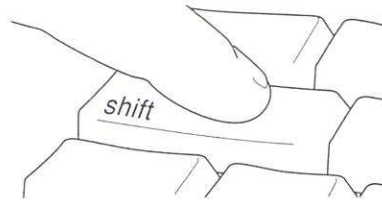

1 To select multiple objects in separate areas, press down the Shift key (on either side of the main keyboard area).

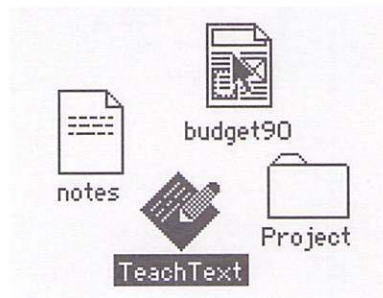

2 While holding down the Shift key, click each object that you want to select.

Each object becomes highlighted when you click it. Clicking an already-selected object with the Shift key held down deselects (removes the highlighting from) that object.

- ❖ *Shift-clicking is also used for:* selecting multiple items in separate places when the contents of a window are displayed as a list. ❖

Working on the desktop

You use the standard mouse operations to manage the objects on the desktop. Most icons can be opened as windows, and you can have multiple windows displayed at the same time. You can also move the windows, change their size, and change the window in which you are working. (See Figure 1-4.)

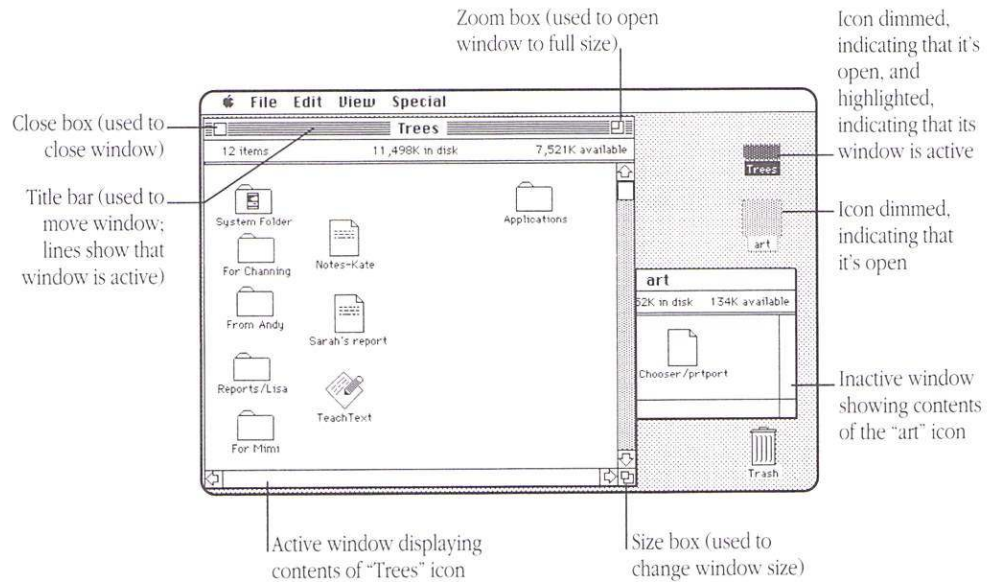
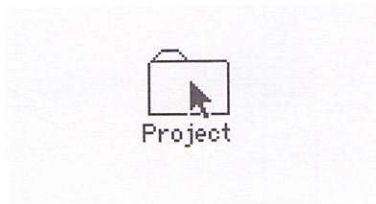

Figure 1-4 Two open windows on the desktop

Opening an icon

The quickest way to open an icon is to double-click it.



1 To open an icon, first point to the icon.

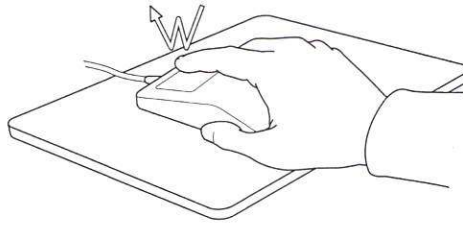

2 Double-click the icon.

If the icon does not open, you may not have clicked quickly enough. Double-click again, with the second click following the first as rapidly as possible.

❖ *Another way to open an icon:* You can also select an icon and use the Open command in the File menu. ❖

➤ *See also:* • “Setting the Double-Clicking Speed” in Chapter 8

Moving a window You drag a window’s title bar to move the window.

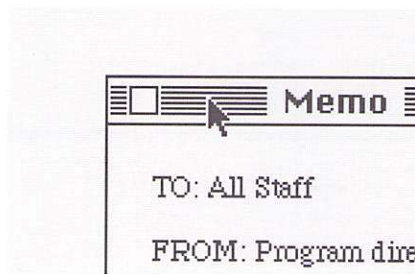

1 To move a window, point to the window’s title bar and drag.

The pointer and an outline of the window move as you drag, indicating the new location. The window remains in its original position until you complete step 2.

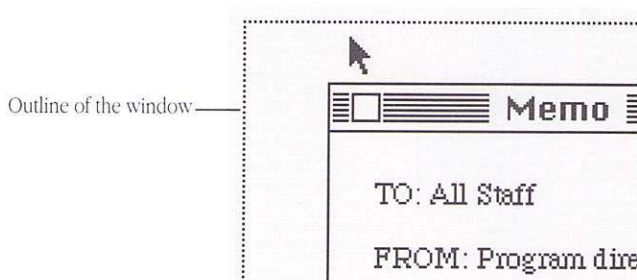

2 Release the mouse button when the outline reaches the location you want.

The window moves to the location of the outline when you release the button.

Resizing a window

You use the size box in the lower-right corner to change a window's size or shape.

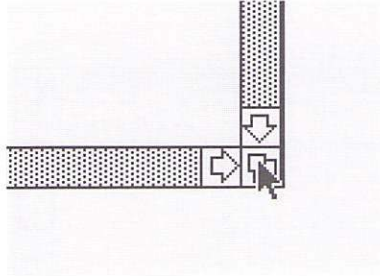

1 To resize a window, point to the size box in the lower-right corner and drag.

Dragging vertically changes height; dragging horizontally changes width; dragging diagonally changes both dimensions. The pointer and an outline of the window's borders move as you drag, indicating the new dimensions.

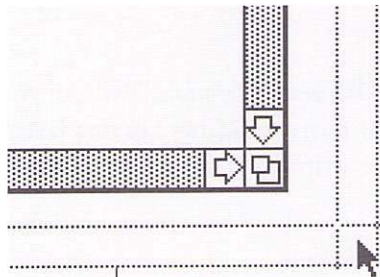

Outline of the window

2 Release the mouse button when the outline indicates the size you want.

The window changes to the size of the outline when you release the button.

Enlarging a window to full size

The zoom box at the right end of a window's title bar offers a quick way to resize a window to its largest standard size (it covers most of the screen).

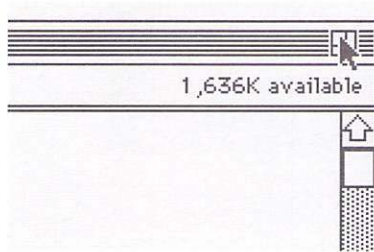

1 To enlarge the window to full size, point to the zoom box at the upper-right corner of the window.

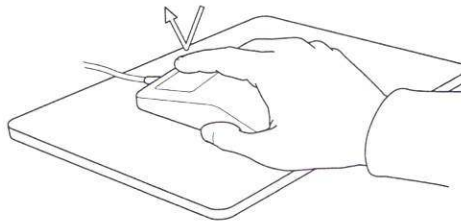

2 Click the zoom box to expand the window.

To return the window to its previous dimensions, click the zoom box again.

Making a window active

The *active window* is where your actions take place. When two or more windows are displayed, only one of them can be active at a time.

You can tell an active window by the horizontal lines in its title bar.

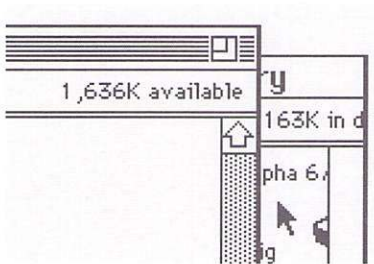

1 To make a window active, first place the pointer anywhere inside the window.

Any part of the window will do, even if most of the window is hidden.

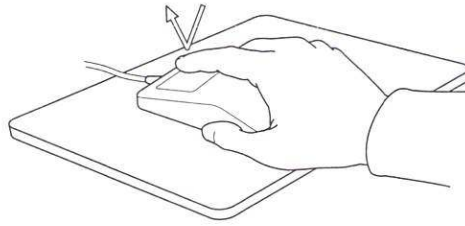

2 Click in the window to make it active.

The window moves to the top layer on the screen. Lines appear in the title bar.

- ❖ *Another way to make a window active:* If you can't see the window you want to make active, you can double-click the icon it belongs to. (You may have to make the currently active window smaller to see the icon.) ❖

Closing a window You use the close box in the upper-left corner to close a window.



1 To close a window, point to the close box at the upper-left corner.

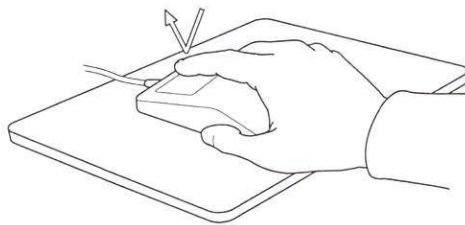

2 Click the box to close the window.

The icon remains selected after the window closes.

- ❖ *Another way to close a window:* You can use the Close command in the File menu to close the active window. ❖

Discarding an icon

You can clear an icon from the desktop by dragging it to the Trash, located at the bottom-right corner of the desktop. To erase that icon's content, however, you have to choose the Empty Trash command from the Special menu.

- ▲ **Warning:** The Trash is emptied automatically when you shut down or turn off the computer, when you start a program, or when you eject a floppy disk from which you discarded any items. ▲

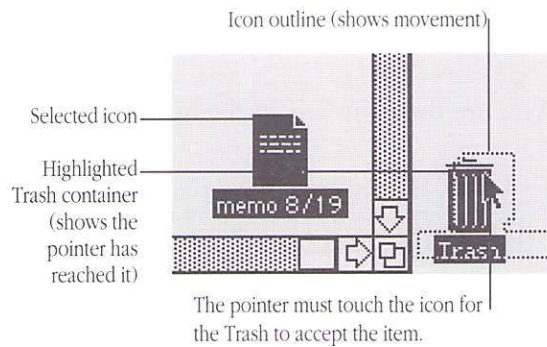

1 To remove an icon, first drag the icon over the Trash so that the Trash icon is highlighted.

The pointer and an outline of the icon move as you drag; the Trash icon becomes highlighted when the pointer reaches it.

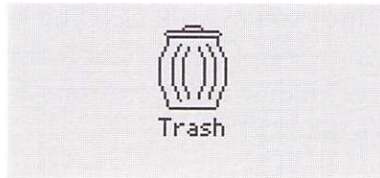

2 Release the mouse button when the Trash icon is highlighted.

When you release the button, the Trash icon bulges to show that something is inside it; the icon is no longer highlighted.

If you change your mind, simply open the Trash as you would any other icon, and drag the icon you discarded back to its original window.



3 To erase the contents, choose Empty Trash from the Special menu.

Once you empty the Trash, the discarded icon and its content are gone.

If you attempt to throw away a program or a locked document, you'll see a message on the screen. You have to confirm that you want to throw away any unlocked program, and the system won't let you discard a locked document or a program that's currently being used.

❖ *Another use for the Trash container:* You can eject a floppy disk from a disk drive by dragging the disk icon to the Trash. This action does *not* erase the disk. ❖

➤ *See also:* • "Ejecting a Disk From the Desktop" in Chapter 6

Viewing the content of a window

When you're working within a window, you can easily change your view of the content by scrolling. The amount you see in the window at any one time depends on the window's size. (See Figure 1-5.)

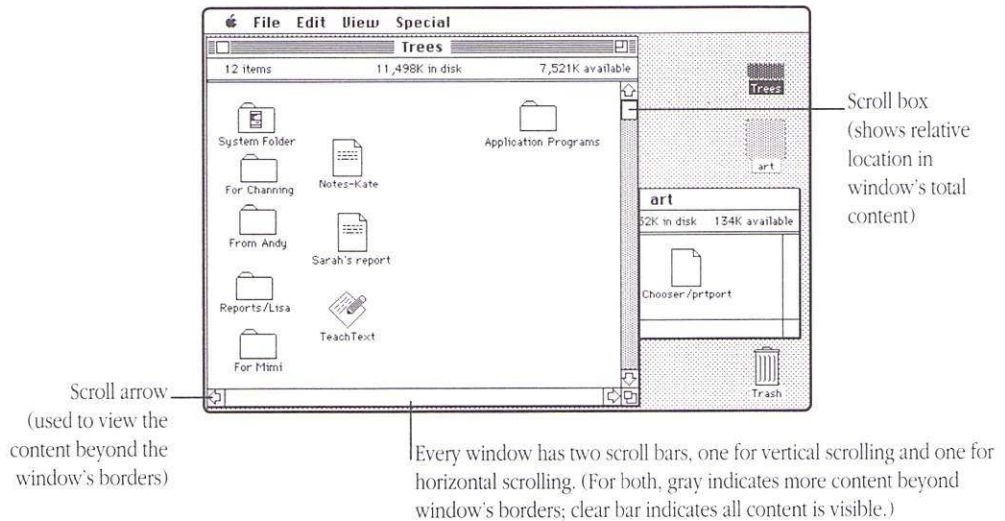
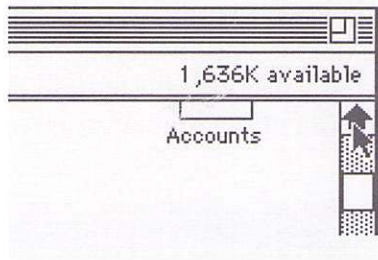

Figure 1-5 Scrolling areas in an active window

Scrolling through a window

You can see the complete content of a window by scrolling through it. To scroll continuously, use the scroll arrows.

The up arrow displays content above the window's top border; the down arrow displays content below the window's bottom border. The left and right arrows display content to the left and right borders of the window, respectively.



1 To scroll through the content of a window, first place the pointer on one of the scroll arrows and hold down the mouse button.

The window's content moves to show the part that had previously been beyond the border in the direction the arrow points. The scroll box also moves in the direction of the arrow.

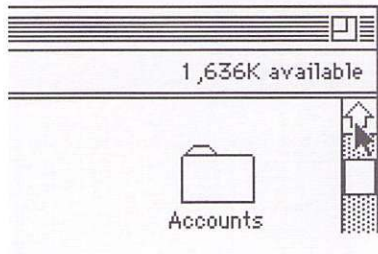

2 Release the mouse button when the part of the content you want is visible.

❖ *Another way to use the scroll arrows:* Simply clicking a scroll arrow scrolls in increments of about one-half inch. ❖

Scrolling to a specific part of a window

You use the scroll box to see the window content corresponding to the box's position in the scroll bar. For example, when the scroll box is near the bottom of a window, you'll see what's near the end of the window's content.

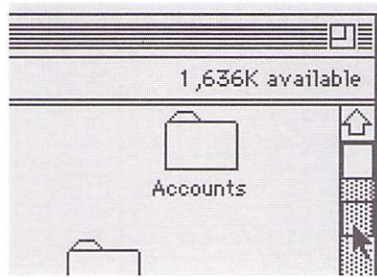

1 To scroll to a specific part of a window, drag the scroll box in the direction of the content you want to see.

The pointer and an outline of the scroll box move as you drag.

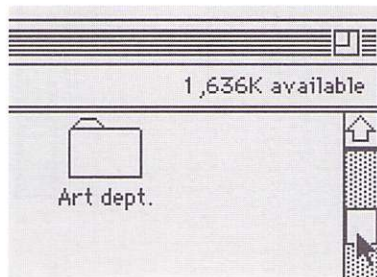

2 Release the mouse button when the scroll box is where you want it.

The scroll box appears in the position where its outline had been when you released the button, and the window's content moves to reveal new content.

Scrolling the length or width of a window

If the right or bottom scroll bar is white, then the entire content of the window vertically or horizontally is visible. But if the scroll bar is gray, then there's more to see. A gray scroll bar is active, and you can click in the gray area to see content beyond what's visible.

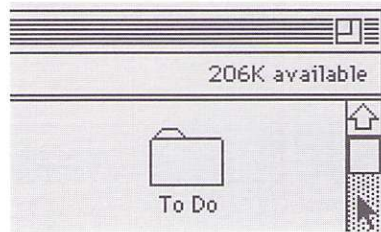

1 To display the next screenful of content, place the pointer in the gray area on the side of the scroll box where you want to see items that are not presently visible.

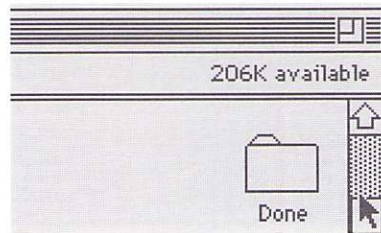

2 Click once to display the next windowful of content.

When you click, a new windowful of content is displayed and the scroll box moves to a new position.

- ❖ *Another way to see more of a window's content:* Resizing the window to larger dimensions, if possible, displays more of its content. ❖

Using menus

Another of the standard Macintosh operations is using menus. Whether you are working on the desktop or in a program, you use menus in a consistent way.

In addition, certain menus and core commands are provided as part of all Macintosh software. These core elements include the Apple, File, and Edit menus and commands such as Cut, Copy, and Paste. (See Figure 1-6.)

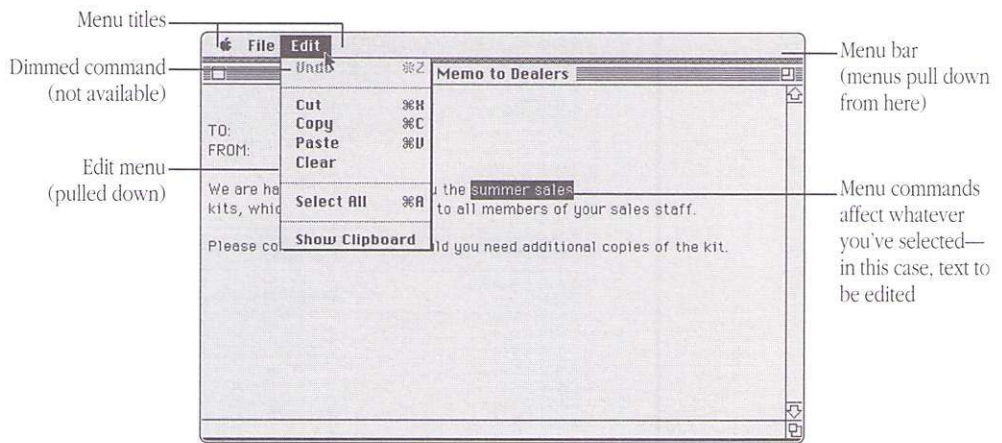
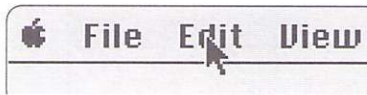

Figure 1-6 Menu bar with the Edit menu pulled down

Pulling down a menu

The principal type of Macintosh menu is called a *pull-down menu*.



1 To pull down a menu, first point to the title of the menu you want in the menu bar at the top of the screen.



2 Press and hold the mouse button to open the menu.

The menu closes when you release the mouse button.

Choosing a menu command

You choose a command with the menu pulled down.



1 To choose a menu command, first pull down the menu by pointing to its title and holding down the mouse button.

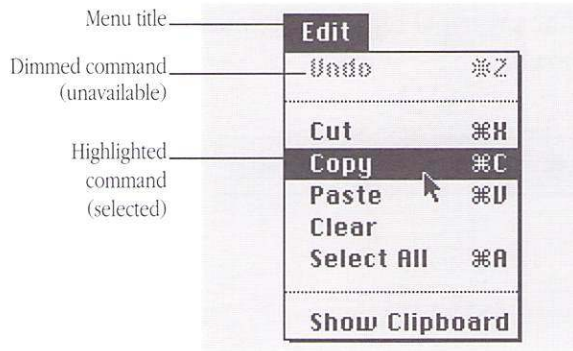

2 Drag the pointer to the command you want.

As you drag, a command that is not dimmed becomes highlighted when the pointer is on it. (Dimmed commands are not available and thus cannot be chosen.)

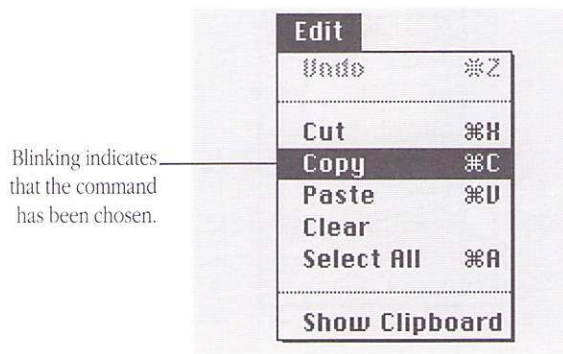

3 Release the mouse button to choose the highlighted command.

The command blinks in the menu, then the menu closes and the command takes effect.

- ❖ *Another way to choose a command:* Many commands have a keyboard equivalent, usually made up of the Command key (indicated by a propeller symbol), which is held down with one other key. Each of these keyboard shortcuts is displayed to the right of the command it represents in the menu. ❖

- *See also:*
 - “Using Special Keys and Indicators on the Keyboard” in this chapter
 - “Adjusting the Blinking of a Selected Menu Item” in Chapter 8

Using a submenu

Some menus have submenus associated with them. You use a variation of dragging to choose commands from the submenus. A submenu is indicated by a small black triangle pointing to the right, next to the command name. The submenu is displayed when you drag over the menu item to which it is subsidiary.

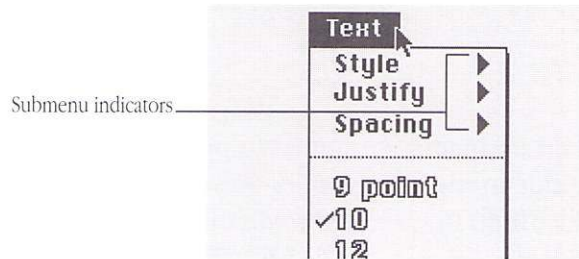

1 To use a submenu, first pull down its corresponding menu.

A small triangle at the right of a menu item shows that the item has a submenu.

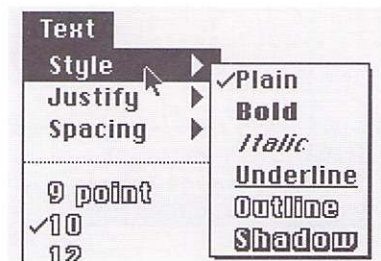

2 Drag the pointer to the item with a submenu you want to open.

When the item is highlighted in the menu, the submenu opens.

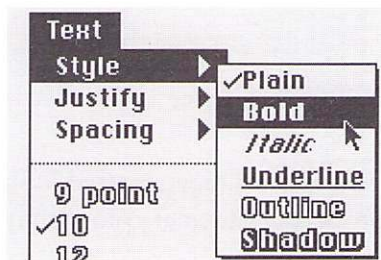

3 Drag diagonally onto the submenu until the command you want becomes highlighted.

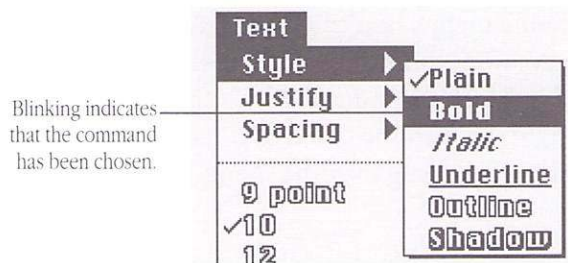

4 Release the mouse button to choose the highlighted submenu command.

The command blinks in the submenu, then the submenu and menu close and the command is initiated.

Using a pop-up menu

Pop-up menus are similar to pull-down menus, but they don't reside in the menu bar. A common example is the pop-up menu that indicates levels of folders on a disk, in the on-screen box called a *directory dialog box* with which you sometimes open and save documents. (See Figure 1-7.)

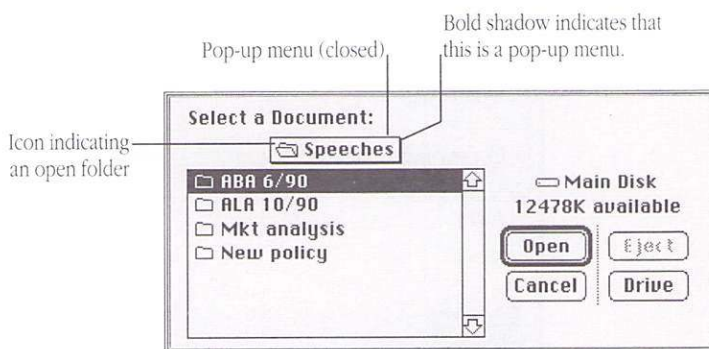
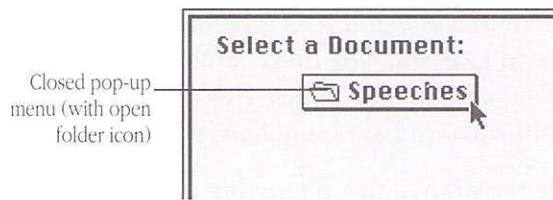

Figure 1-7 A pop-up menu in a directory dialog box

This type of menu is used in some programs to choose settings or variables such as color or units of measure.

A pop-up menu can extend above or below its title, and some extend in both directions. The item displayed as the menu title is the item that is currently in effect.



1 To use a pop-up menu, first point to the menu's title and hold down the mouse button.

The menu opens, showing some or all of the items available. (Some pop-up menus extend up as well as down from the title; you drag upward to see the additional items in such menus.)

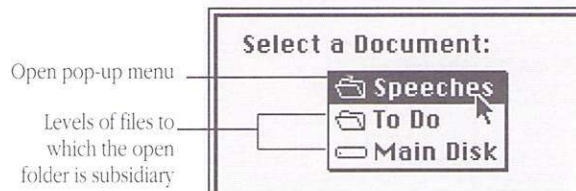

2 Drag the pointer to the item you want in the pop-up menu.

The item becomes highlighted when the pointer is on it.

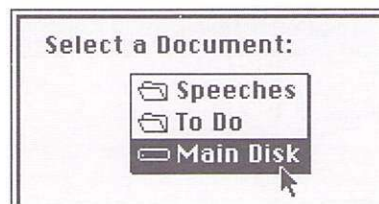

3 Release the mouse button to select the highlighted item.

The pop-up menu closes and the item selected now appears as the menu title.

➤ *See also:* • “Moving Quickly Through Levels of Folders When Using a Program” in Chapter 5

Responding to messages on the screen

The Macintosh has several standard ways of displaying messages on the screen. The most common form of message is a *dialog box*, which requires that you choose an option or supply needed information before the Macintosh does what you want it to do.

Some of the most frequently used commands on the Macintosh present dialog boxes. You can readily spot such commands, because their names are followed by three dots in the menu. For example, the Open command in the File menu displays a directory dialog box, which shows a list of the files on the current disk or in the open folder. (See Figure 1-8.)

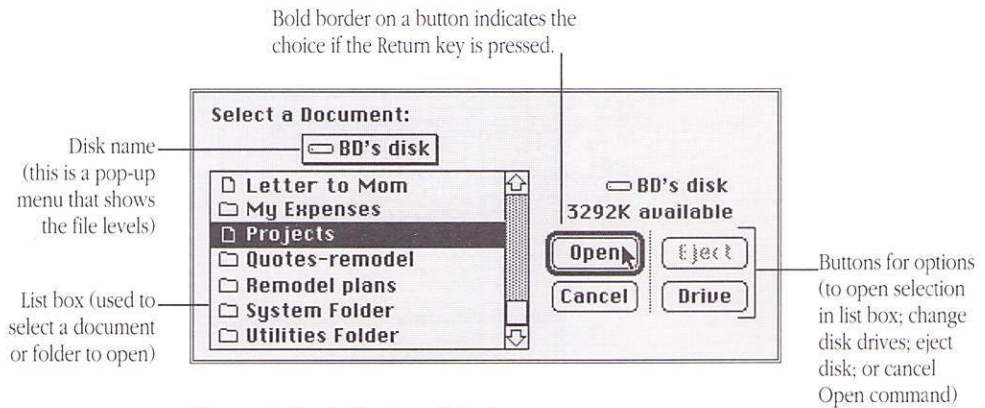
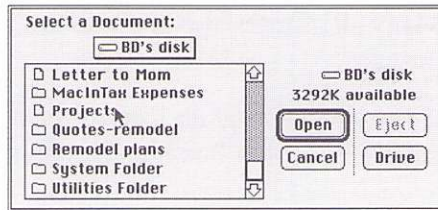

Figure 1-8 A directory dialog box

➤ See also: •“Using Menus” in this chapter

Using a dialog box

You select items and choose options in a dialog box with standard operations—scrolling, pointing, and clicking. Here's how you would use the directory dialog box to open the document “Projects” in Figure 1-8.



1 To use the directory dialog box, first click the name of the document or folder you want to open.

The name appears highlighted in the list when you select it.

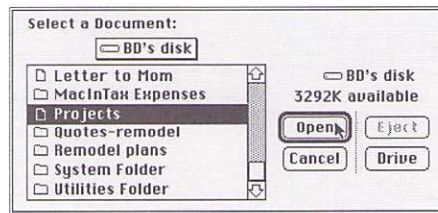

2 Click the Open button.

The dialog box disappears and the item you selected opens.

❖ *Another way to open a document or folder:* Double-clicking the name of a document or folder in the list opens it. ❖

Using alert boxes

Another type of dialog box, the *alert box*, is designed to keep you from mistakenly losing some of your work or discarding an application program. Its message warns you that you may be doing something you didn't intend and asks that you confirm that you want to go ahead with the action.

Many alert boxes also add a sound to warn you of a possible mistake.

If you drag a program icon to the Trash (thereby discarding it), you'll see an alert box like the one in the following steps.

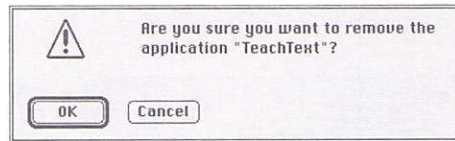

1 To use an alert box, first read the message displayed and make sure that you want to complete the action you initiated.

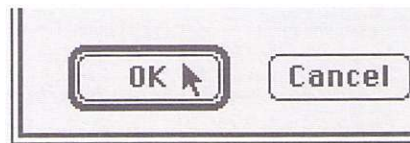

2 Click the OK button to complete the action, or click the Cancel button to cancel the action.

❖ *Return key shortcut:* You can press Return instead of clicking the OK button. (Pressing Return initiates the action for the button with a bold outline.) ❖

➤ *See also:* • "Setting the Alert Sound" in Chapter 8

Basic editing on the desktop

The Macintosh has a number of standard editing capabilities, which you can use on the desktop or in an application program. These built-in features allow you to change disk and document names with ease, to copy text or graphics between programs, and to save frequently used information for quick retrieval.

This section introduces the fundamental text-editing operations you can use on the desktop or in programs.

► *See also:* • “Editing Documents” in Chapter 3

Changing all of an icon’s name

You can easily change an icon’s name.



1 To change an icon’s name, first select the icon by clicking it.

Selecting the icon also selects its entire name.

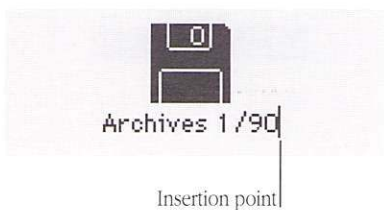

2 Type a new name for the icon.

When you begin typing, the new text appears in place of the old. The *insertion point*—a thin vertical line that marks the place of current activity—blinks at the end of the text you type.

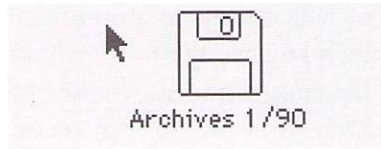

3 Place the pointer anywhere outside the icon and click.

When you move the mouse, the pointer reappears. When you click, the insertion point disappears and the icon is deselected.

- ❖ *Another way to save an icon's name change:* Pressing the Return key after typing new text for an icon's name saves the change; the icon remains highlighted. ❖

Selecting part of the text in an icon's name

You use dragging to select part of an icon's text. Dragging across text is the way you select it in application programs as well as on the desktop.



1 To select part of the text in an icon's name, first select the icon by clicking it.

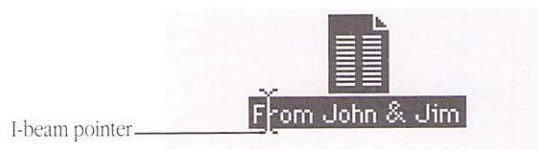

2 Place the pointer over the name.

When you place the pointer over the text portion of the icon, the arrow changes to an *I-beam*—a vertical symbol that resembles a capital letter 'I'.



3 Position the I-beam just to the left of the first character in the section you want to select, and press and hold the mouse button.

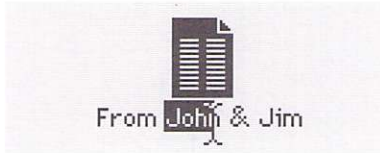

4 Drag the I-beam over the part of the name you want to select.

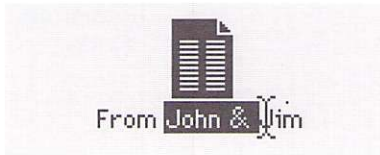

5 Release the mouse button when the I-beam is just to the right of the last character in the part you want to select.

- ❖ *Selecting and deselecting text:* When you're editing text other than icon names, you can extend selected text one character by pressing Shift–Right Arrow, and you can deselect one character by pressing Shift–Left Arrow. Repeat these actions as necessary to change the amount of text selected. ❖

Replacing selected text in an icon's name

You simply type over selected text to replace it.



1 To replace selected text, first select the text you want to replace.

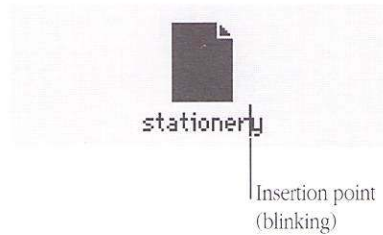

2 Type the new text you want to replace the selection.

The selected text disappears as you begin typing. The insertion point blinks at the end of the new text you type.

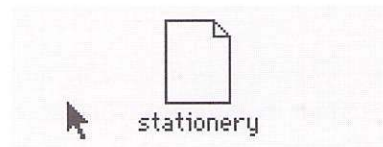

3 Place the pointer anywhere outside the icon and click.

When you click, the insertion point disappears and the icon is deselected.

- ❖ *Another way to save an icon's name change:* Pressing the Return key after typing new text for an icon's name saves the change; the icon remains highlighted. ❖

Deleting selected text from an icon's name

You use the Delete key to remove selected text. (On some keyboards, this key is labeled Backspace rather than Delete.)



1 To delete text from an icon's name, first select the text you want to delete.

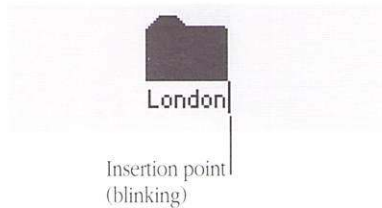

2 Press the Delete or Backspace key to delete the selected text.

The selected text disappears; the insertion point blinks at the place where text was deleted.

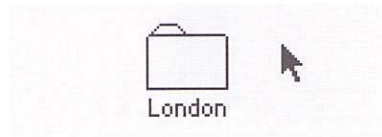

3 Place the pointer anywhere outside the icon and click.

When you click, the insertion point disappears and the icon is deselected.

- ❖ *Another way to delete text:* You can also use the Cut command or Clear command in the Edit menu to delete selected text. Cut removes text and places it in the computer's memory in an area called the *Clipboard*, from which it can be pasted elsewhere. Clear simply removes the text. ❖

➤ *See also:* • "Deleting Text and Images" in Chapter 3

Inserting text in an icon's name

You can easily insert text without deleting what's already there.



1 To insert text in an icon's name, first select the icon.

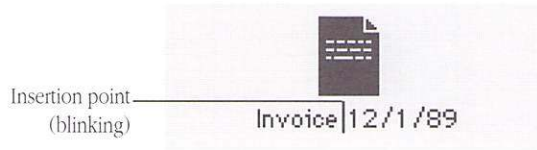

2 Place the I-beam pointer at the spot in the name where you want to insert text and click.

A blinking insertion point appears at the spot where you clicked.

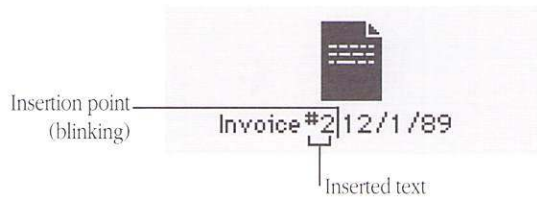

3 Type the text you want to insert.

As you type, the text on either side of the insertion point moves to make room for the new characters.

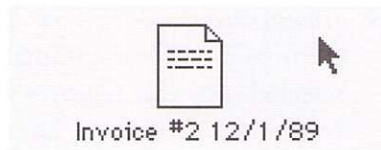

4 Place the pointer anywhere outside the icon and its name and click.

When you click, the insertion point disappears and the icon is deselected.

Using the Control Panel

You can change many of the standard settings for your Macintosh by using the Control Panel. This panel operates as a *desk accessory*, a “mini-application” that is available no matter what other work you’re doing with the computer.

The Control Panel has several different sections; the ones included with your system depend on the model of the Macintosh you use. For example, if you have a Macintosh IIfx with a color monitor, you will have sections of the Control Panel for the monitor and for color, as well as the standard sections for the keyboard, mouse, and general settings.

Figure 1-9 shows the General Control Panel.

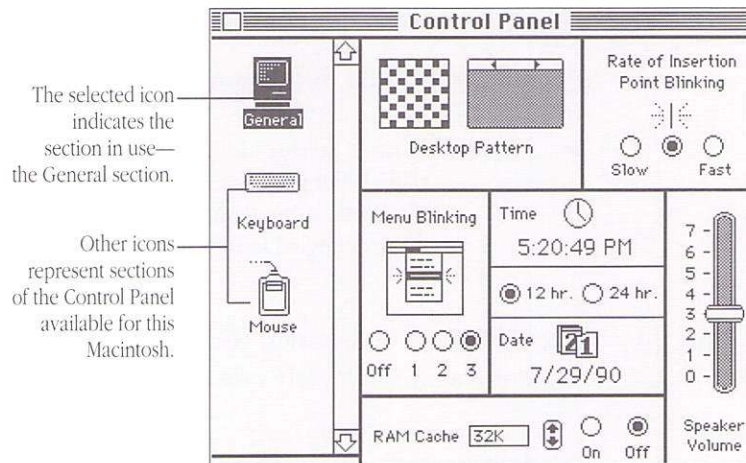

Figure 1-9 The General Control Panel

Control Panel actions

The settings you can adjust in the Control Panel include:

- pattern and colors on the desktop
- speed of blinking of selected menu items
- speed of blinking of insertion point for editing
- date, time, and display of time as 12-hour or 24-hour clock
- speaker volume
- size of RAM cache
- rate of character repetition when a key is pressed
- movement of the pointer from one monitor to another
- disk drive to be used for startup of system
- sound to be used for warning from system

- *See also:*
- “Basic Editing on the Desktop” in this chapter
 - “Specifying Items to Be Opened at Startup” in Chapter 2
 - “Adjusting the RAM Cache” in Chapter 3
 - “Installing a Desk Accessory” in Chapter 8

Opening the Control Panel

Like other desk accessories, the Control Panel resides in the Apple menu at the far left side of the menu bar.



1 To open the Control Panel, first open the Apple menu at the left side of the menu bar.



2 Drag the pointer to the Control Panel command, then release the mouse button.

The Control Panel appears. The General section of the Control Panel is always shown initially.

Changing sections of the Control Panel

You change Control Panel sections by selecting the icon for the part of the system you want to adjust at the left side of the panel.

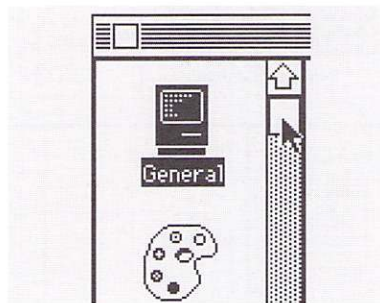

1 To change sections of the Control Panel, first scroll if necessary to locate the icon for the section you want.

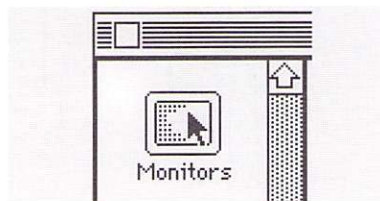

2 Click the icon of the Control Panel section you want to display.

When you click, the section of the panel represented by the icon appears.

❖ *Special sections of the Control Panel:* If your Macintosh model has its own special section of the Control Panel, refer to *Special Options and Technical Information* for your Macintosh model for details of using that panel. ❖

Changing settings in the Control Panel

For most settings, you click a button to make a change.

A few settings, such as time and date, are adjusted by selecting one of the existing numbers (the hour or month, for example) and then using small up and down arrows to change to the desired number.

You adjust the speaker volume by dragging the bar up or down the numeric scale.

Figure 1-10 shows the adjustments in the General Control Panel.

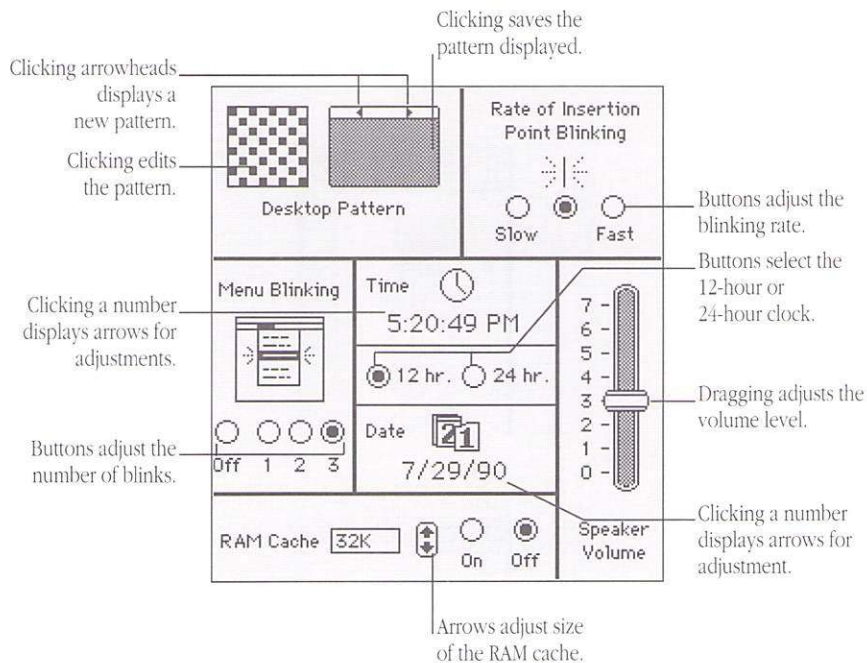

Figure 1-10 Adjustments for settings in the General Control Panel

- See also:
- "Adjusting the RAM Cache" in Chapter 3
 - Chapter 8, "Personalizing Your Macintosh Work Space"

Using the Chooser

The Chooser is a desk accessory, supplied with the system software, that you use to specify which printer you will use. You also use the Chooser to select devices such as file servers on the AppleTalk™ network system and to adjust some settings related to printing and network use. (See Figure 1-11.)

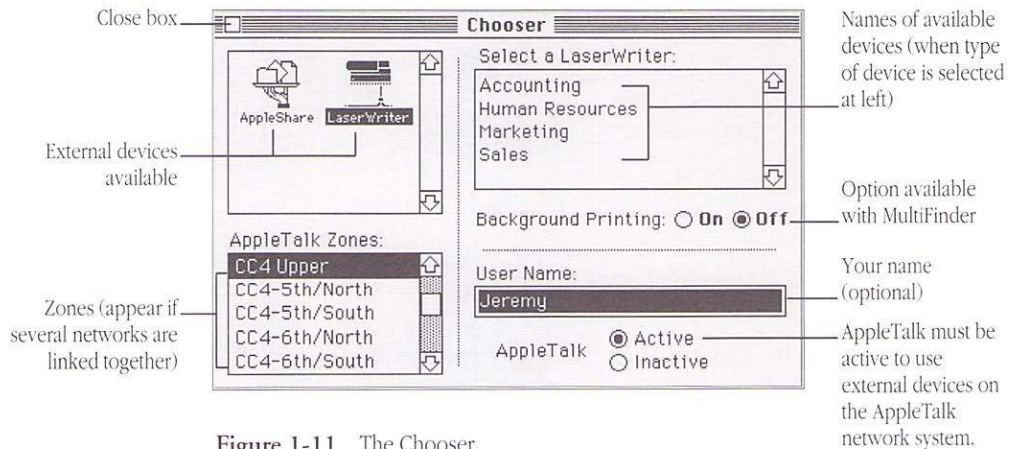
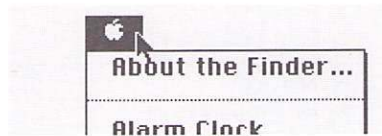

Figure 1-11 The Chooser

Opening the Chooser

Like the Control Panel, the Chooser is a desk accessory.



1 To open the Chooser, first open the Apple menu at the far left side of the menu bar.

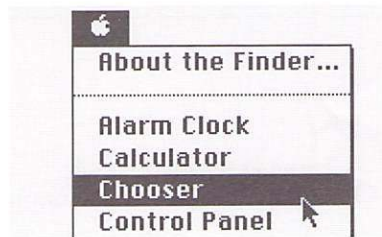

2 Drag the pointer to the Chooser command, then release the mouse button.

The menu closes and the Chooser appears.

Selecting a printer or other device in the Chooser

You designate a printer or other device by selecting its icon, its location (if necessary), and its name in the Chooser.

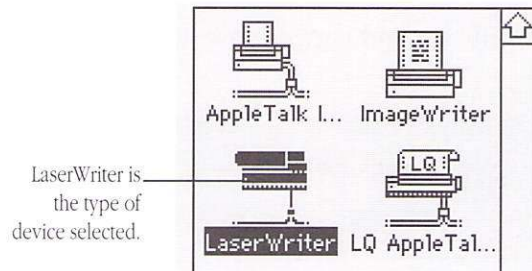

1 Select the type of device you want to use by clicking its icon in the upper-left area of the Chooser.



2 If necessary, select the zone in which you want to use a device by clicking its name in the lower-left area of the Chooser.

The list of zones appears only if your Macintosh is on a network that is linked to other networks.

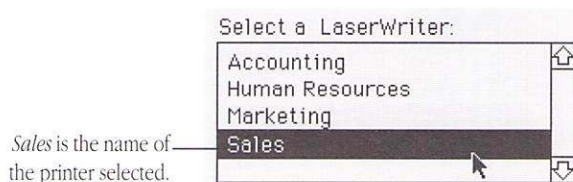

3 Select the specific device you want to use by clicking its name in the list at the upper-right area of the Chooser.

It's a good idea to close the Chooser, although you can leave it open.

Once you've selected the name of a device, such as a LaserWriter™, your Macintosh will use that device until you select a different one with the Chooser.

Adjusting Chooser settings

You also use the Chooser to adjust three settings that relate to using a printer or a network device. You can

- make AppleTalk active or inactive
- turn background printing on or off (for MultiFinder™ use)
- enter or change your user name

Figure 1-12 shows the adjustments for these settings.

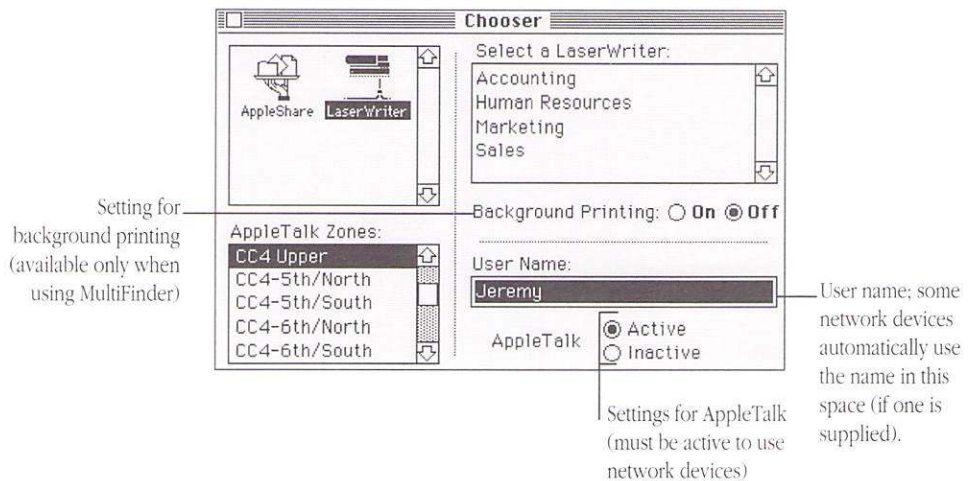

Figure 1-12 Adjustments for settings in the Chooser

Once you've adjusted a Chooser setting, your Macintosh maintains that setting until you change it.

- *See also:*
- “Managing Multiple Programs Using MultiFinder” in Chapter 3
 - “Printing While Using the Computer for Other Work” in Chapter 4
 - “Preparing the Macintosh System Software for Networking” in Chapter 7
 - “Gaining Access to an AppleShare File Server” in Chapter 7

Using special keys and indicators on the keyboard

The Macintosh keyboard resembles a typewriter keyboard, but some of its keys have special purposes. These special keys and their primary uses are summarized in Figure 1-13.











 <p>Escape key—used for special purposes in some programs.</p>	 <p>Power On key—turns on the Macintosh.</p>
 <p>Function key—each of these can be assigned a command with a special program.</p>	 <p>Lights that are on when a locking key is engaged.</p>
 <p>Control key—works in combination with other keys to provide shortcuts and modify other actions.</p>	 <p>Enter key—used in some programs; often has the same function as the Return key.</p>
 <p>Option key—used in combination with other keys to produce special characters.</p>	 <p>Delete key—used to delete selected items.</p>
 <p>Command key—used in combination with other keys to initiate commands.</p>	 <p>Arrow keys—move the insertion point; often an alternative to the mouse.</p>

Figure 1-13 Special keys and indicators used on Macintosh keyboards

The location of special keys varies on the different keyboards available for use with Macintosh models; some keyboards do not include all of these special keys and lights.

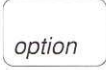
➤ *See also:* • Appendix A, “Keyboards and Character Sets”

Turning the Macintosh on and off

All Macintosh models have a power switch on the back of their cases. The location of the switch varies among different Macintosh models, however, and the switch is not the principal method for turning some models on and off.

Power switch locations

On compact models—models with a built-in monitor—the power switch is located at the right rear side of the computer. (See Figure 1-14.)

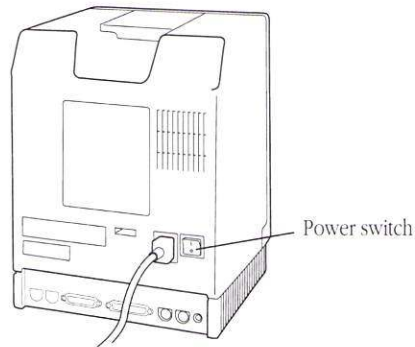

Figure 1-14 The power switch on the Macintosh SE/30

On modular Macintosh models—models with separate monitors—the power switch is located on the left rear side of the computer. (See Figure 1-15.)

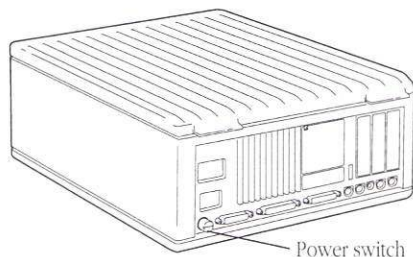

Figure 1-15 Power switch on the Macintosh IIci

One type of Macintosh, the Macintosh Portable, does not have a power switch. It operates on battery power.

Turning on a compact Macintosh model

You turn on a compact Macintosh model with the power switch.

- ❖ *Turning on an external hard disk drive:* If your system has an external hard disk drive, you must turn the external drive on before you turn on the Macintosh. Otherwise, the Macintosh will not recognize the external drive. ❖

➤ *See also:* • “Troubleshooting” in Chapter 10

Turning on a modular Macintosh model

The recommended way to turn on the most modular Macintosh models is by pressing the Power On key on the keyboard. This key is located at the top of the keyboard and has a triangle symbol on it. On some keyboards the Power On key is rectangular; on others it is square. (See Figure 1-16.)

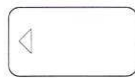

Power On key,
top center of keyboard



Power On key,
top right corner of keyboard

Figure 1-16 The rectangular and square Power On keys

If the Power On key does not work for your model, use the power switch on the back of the computer to turn the Macintosh on.

❖ *Turning on an external hard disk drive:* If your system has an external hard disk drive, you must turn on the external drive before you turn on the Macintosh. Otherwise, the Macintosh will not recognize the external drive. ❖

➤ *See also:*

- “Troubleshooting” in Chapter 10
- Appendix A, “Keyboards and Character Sets”

Turning off the Macintosh

The recommended way to turn off all Macintosh models is by using the Shut Down command in the Special menu. This command signals the system software to prepare all files and disks in use for shutdown.

The Shut Down command also turns off power in some Macintosh models. In other models, this command prepares the system for shutdown and then displays a message that the computer’s power switch can now be turned off.

➤ *See also:*

- “Shutting Down the Computer” in Chapter 3



Starting Up

Setting up your computer has two phases: the first is assembling the hardware components; the second is preparing the *system software*, which the Macintosh uses for its basic operations.

This chapter provides instructions for preparing the system software to work efficiently with all devices in your Macintosh system.

If your system has a hard disk drive, you may want to review “Installing System Software,” “Creating a Customized System,” and “Specifying Items to Be Opened at Startup,” later in this chapter.

If your system has only floppy disk drives, you will probably want to review “Installing System Software,” “Making an Extra Startup Disk,” and “Creating a Small System.”

Preparing the Macintosh hardware

The precise steps in setting up your Macintosh hardware depend on which model of the computer you have. The setup guide, *Setting Up Your Macintosh*, that came with your model provides detailed instructions for putting the system together.

If you set up the Macintosh and the computer or monitor does not turn on, see “Troubleshooting” in Chapter 10 for assistance.

Preparing your system software

The system software manages Macintosh operations. It transmits information to and from disks, printers, and other hardware components, establishes and tracks files, and directs processing inside the computer. Most system software activity is invisible, but *application programs*—the software used for word processing, spreadsheets, and other specialized work—rest on the foundation system software provides.

❖ *System software already installed:* If you purchased a Macintosh model with an internal hard disk drive, the system software was probably already installed at the factory. You’ll recognize a ready-to-run Macintosh when you turn it on; after a few seconds you’ll see a “happy Macintosh” icon, then the desktop will appear on the screen, with icons for the hard disk and the Trash. ❖

▲ **Warning:** If you received a hard disk with A/UX™ installed on it, *do not* initialize that disk; doing so will erase A/UX. Instead, see the *A/UX Installation Guide* for instructions on installing system software. ▲

You prepare the system software for your Macintosh by installing it on a disk and thereby creating one or more *startup disks*—disks that contain the system software necessary to use your Macintosh model and the devices connected to it.

Installing system software creates a System Folder that contains the *system files*, *drivers*, and other kinds of resources your Macintosh needs. Figure 2-1 shows the icons for a system file and a driver.

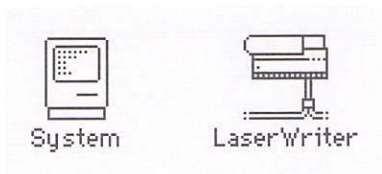
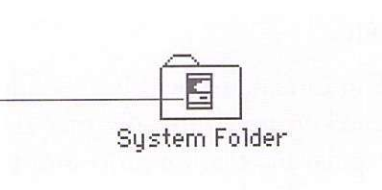

Figure 2-1 Icons for a system file (System) and a driver (LaserWriter)

Checking system software that is already installed

If your system software is already installed, you can skip the installation steps. But it's a good idea to check the contents of the System Folder on your hard disk to verify that it contains the system files and drivers you need.

The Macintosh icon indicates that this system has been installed.



Open the System Folder and check to see that it contains icons for the devices used with your Macintosh.

Figure 2-2 shows the System Folder for a Macintosh configured for a separate monitor and LaserWriter and ImageWriter™ printers.

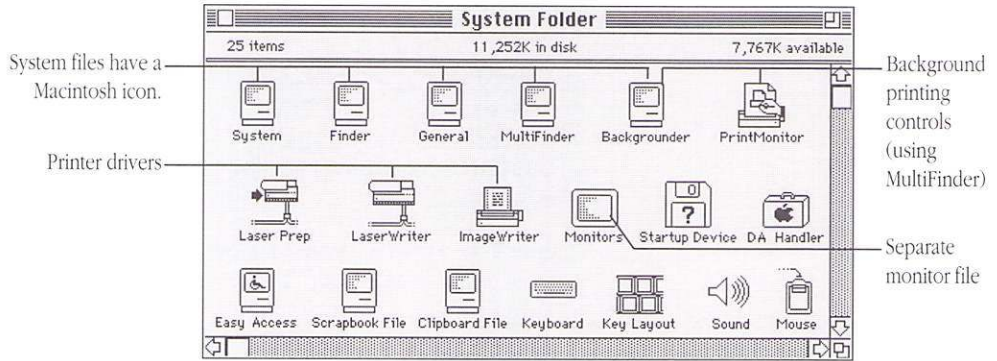

Figure 2-2 System Folder contents for a Macintosh with a separate monitor

If your System Folder does not contain drivers for optional devices used with your Macintosh, you can add the necessary ones.

You can add some drivers—including the ones for the LaserWriter II, ImageWriter II, and Apple Scanner—during the regular installation process or by copying them into the System Folder.

Consult the documentation for the printer, scanner, or other devices connected to your Macintosh for information about which drivers they require and instructions for adding them to your system.

Installing system software

You use the program named Installer to prepare the system software for your Macintosh model, either when you first begin using the computer or when you want to update your system with a new version of system software.

To install the system software, you will need

- the *System Tools* disk (which contains the Installer program)
- the *Printing Tools* disk
- *Utilities* disks 1 and 2 (you may not need to use both, however)
- an initialized hard disk or an initialized floppy disk

△ **Important:** Apple recommends one of two minimum hardware configurations for installation and use of System 6.0 or later versions of the Macintosh system software: (1) a hard disk and one floppy disk drive; or (2) two floppy disk drives. (It is possible to install the system software on a Macintosh with one floppy disk drive, however.) △

The Installer provides two options—Easy Install and Customize. These instructions cover the Easy Install process, which is suitable for most Macintosh users. (To learn more about the Customize option, see “Creating a Customized System” later in this chapter.)

When you start the Installer, the software determines which Macintosh model you are using and prepares to install the standard software for that model. The Easy Install process installs the drivers for all available printers on Macintosh models that have a hard disk.

You begin the installation procedure with your Macintosh turned off.

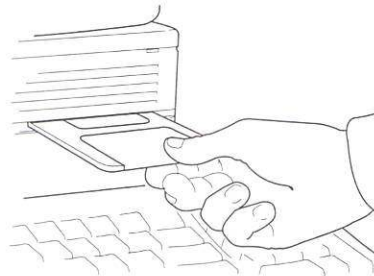

1 To install the system software, first put the *System Startup* disk into the internal disk drive, and turn on the computer.

(Use the *System Tools* if you are updating your system software with an upgrade kit.)

If your Macintosh has two internal drives, use the lower drive or the rightmost drive.

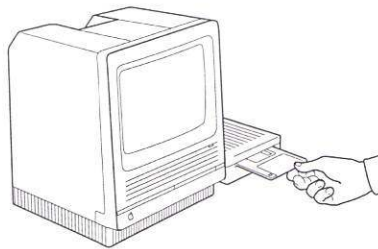

2 If you do not have a hard disk, put an initialized floppy disk in the second drive; otherwise, go on to the next step.



System Startup

3 If necessary, double-click the *System Startup* disk icon .

(If you have inserted the *System Tools* disk from an upgrade kit, double-click the *System Tools* icon.)



4 Double-click the Installer icon to open it.

The Installer's Welcome dialog box appears.



5 Click OK to clear the Welcome box.

The Installer's primary dialog box appears.

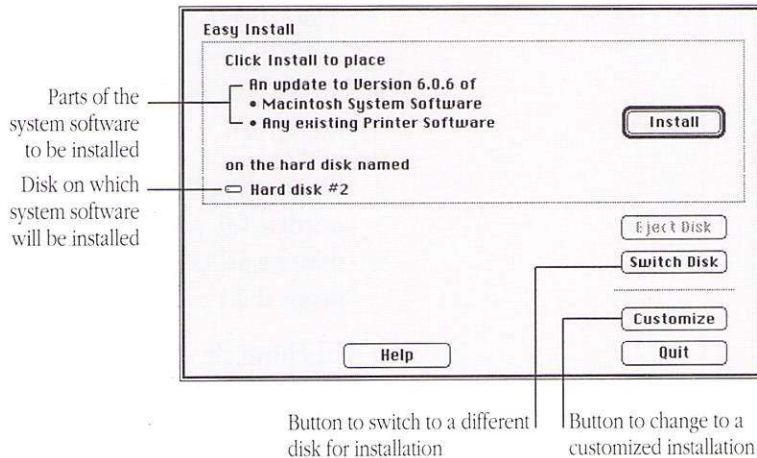

6 Make sure that the disk indicated on the screen is the one on which you want to install the system.

If the wrong hard disk or floppy disk is indicated, click the Switch Disk button until the correct hard disk's name appears, or click Eject Disk to change floppy disks.

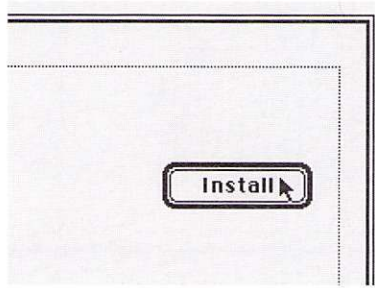

7 Click Install.

The Installer begins to install the system software for your Macintosh model. On-screen messages list the disks needed and report copying status.

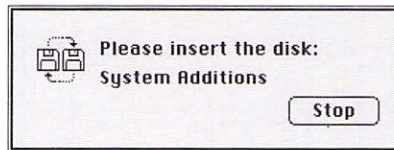

8 When the *System Startup* disk is ejected and you see a message to insert the *System Additions disk*, insert the disk.

(If you are updating your System software with an upgrade kit and the *Systems Tools* disk is ejected, you are asked to insert a different disk; just follow the instructions on the screen.)

Depending on the software needed for your system, you may be asked to switch disks more than once.

Clicking the Stop button cancels the installation.

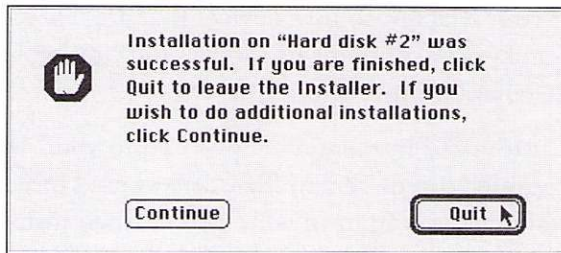

9 When you see a message reporting that the installation was successful, click **Quit**.

The Installer window closes. (If for some reason the installation was not successful, you'll see a different message, and you can begin installation again.)



10 Choose **Restart** from the **Special** menu to begin working with your new system.

The Macintosh restarts with the newly installed system.

If you do not have a hard disk, you'll need to reinsert the newly created startup disk into a disk drive when you see the blinking question mark icon.

- *See also:*
- "Printing Color or Gray-Scale Documents" in Chapter 4
 - "Initializing and Naming a Disk" in Chapter 6
 - "Initializing and Naming a Hard Disk for the First Time" in Chapter 6
 - "Moving Fonts and Desk Accessories" in Chapter 8

If your Macintosh uses devices that are not included in the standard software for its model, you can use the customized installation process to create or modify your system.

Customized installation allows you to select the exact combination of system files, drivers, and other kinds of resources you want in your system, then installs them in your System Folder. You can use this process for initial system installation, for updating to a new version of system software, or for saving space on your startup disk by eliminating drivers that aren't essential.

You begin the installation procedure with your Macintosh turned off.

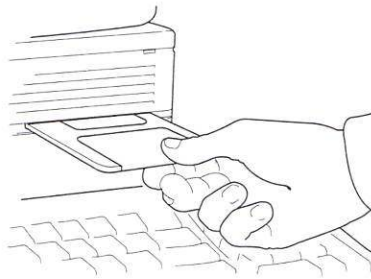

1 To create a customized system, first put the *System Startup* disk into the internal disk drive, then turn on the computer.

Use the System Tools disk if you are updating your system software with an upgrade kit.

If your Macintosh has two internal drives, use the lower drive or the rightmost drive.

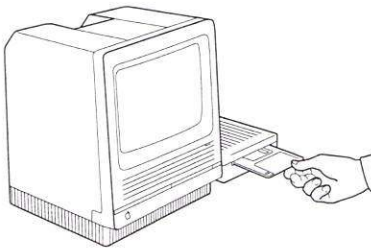

2 If you do not have a hard disk, put an initialized floppy disk in the second drive; otherwise, go on to the next step.

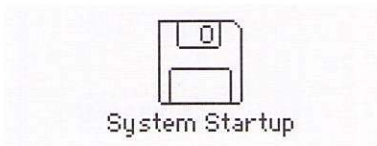

3 If necessary, double-click to open the *System Startup* (or *Systems Tools*) disk icon.



4 Double-click to open the Installer icon.

The Installer's Welcome dialog box appears.



5 Click OK to clear the Welcome box.

The Installer's primary dialog box appears.

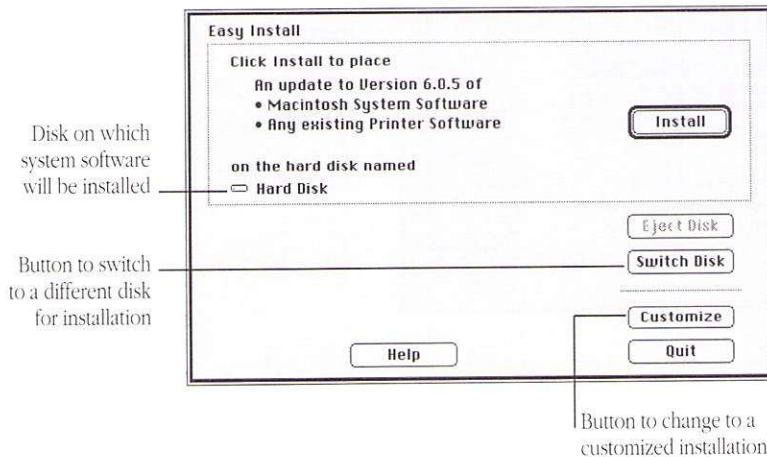

6 Make sure that the disk indicated on the screen is the one on which you want to install the system.

If the wrong hard disk or floppy disk is indicated, click the Switch Disk button until the correct hard disk's name appears, or click Eject Disk to change floppy disks.

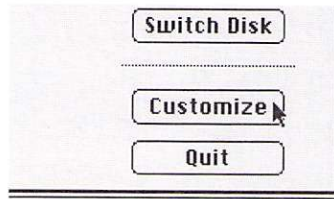

7 Click Customize.

The custom installation screen appears, with a list box showing all drivers provided with the system software and a choice of standard or minimal system files for each Macintosh model.

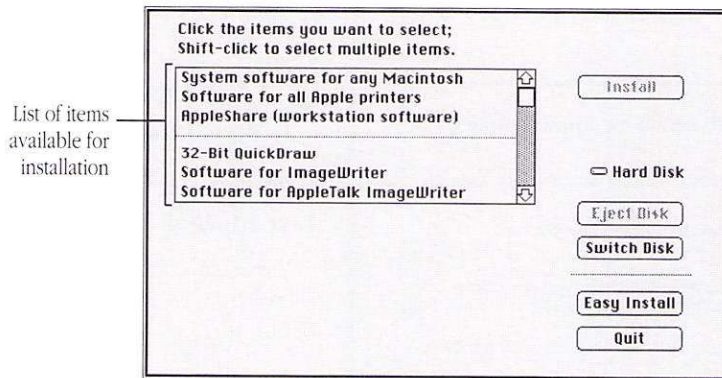

8 Scroll through the list of items and Shift-click the ones you want to install.

As you select items, their names appear at the lower-left portion of the dialog box. (If you select only one item, details about it appear.)

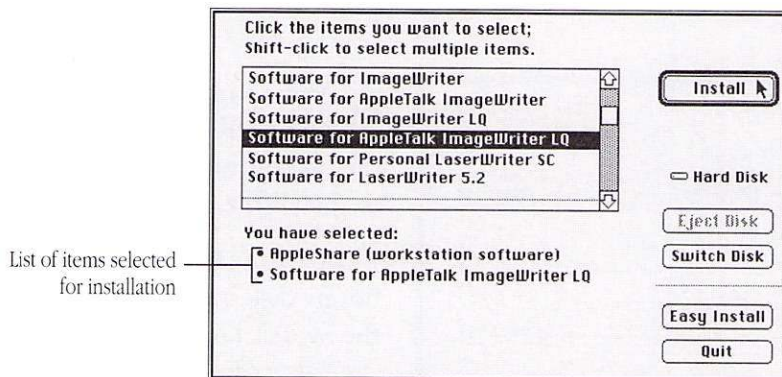

9 Click the Install button to install the selected items.

The Installer begins the installation. On-screen messages report copying status.

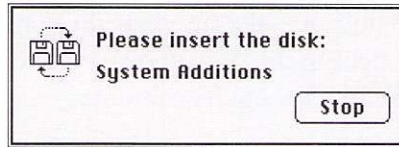

10 If the *System Startup* disk is ejected, insert the *System Additions* disk as requested.

(If you are updating your system software with an upgrade kit and the *System Tools* disk is ejected, you are asked to insert a different disk; just follow the instructions on the screen.)

Clicking the Stop button cancels the installation.



11 When you see a message reporting that installation was successful, click Quit.

The Installer window closes. (If you see a message that the installation was not successful, begin the process again.)



12 Choose Restart from the Special menu.

The Macintosh restarts with the newly installed system.

If you do not have a hard disk, reinsert the newly created startup disk when you see the blinking question mark icon. If you see a dialog box asking you to name your Macintosh, type a name and click OK.

You can make sure that the correct items were installed by opening the startup disk's icon, then opening the System Folder and reviewing its contents.

- See also:
- “Printing Color or Gray-Scale Documents” in Chapter 4
 - “Moving Fonts and Desk Accessories” in Chapter 8

Installing system software on a Macintosh with only one disk drive

You can install the system software if your Macintosh has only one floppy disk drive (and no hard disk), but the process will involve many disk swaps as you copy the necessary files from the four system software disks to the disk on which the system is being installed.

The installation process follows the same steps as those in “Installing System Software” earlier in this chapter, except that you will have to eject the *System Startup* (or *System Tools*) disk and insert an initialized disk after starting the Installer program.

The Installer automatically creates a minimum-sized system and installs only the ImageWriter printer driver when you install on a floppy disk.

Making an extra startup disk

Your Macintosh requires a startup disk—that is, a disk with a System Folder installed on it—whenever you turn on or restart the computer.

If your Macintosh has a hard disk and you have installed the system software on it or the computer came with the system on its hard disk, you already have your startup disk and don't need to create any floppy disks to use as startup disks.

If your Macintosh has only floppy disk drives, you may want to create several startup disks to use with different application programs for convenience.

Once you have installed the system software on one floppy disk, you can simply copy its System Folder to one or more initialized disks to make duplicate startup disks.

To make a new startup disk you need

- a disk with your installed system software (in one disk drive)
- an initialized disk (in the second disk drive)

If your computer has only one disk drive, you can create a startup disk, but you will have to make several disk swaps in the process.

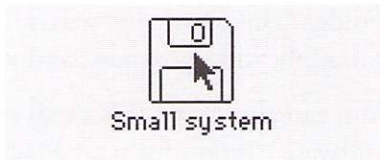

1 To make an extra startup disk, first double-click the icon of a disk that contains your installed system software to open it.

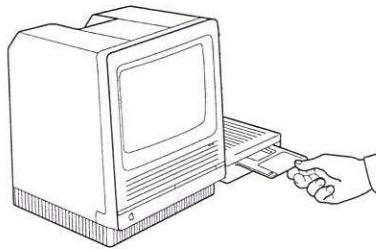

2 Place an initialized disk in the second disk drive.

If you have only one floppy disk drive, eject the disk containing the installed software and then insert an initialized disk. This disk will be your new startup disk.

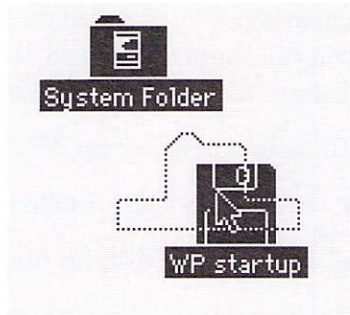

3 Drag the System Folder to the icon of the startup disk you want to create.

The System Folder is copied onto the new startup disk.

This process will require a number of disk swaps on a one-floppy-drive system.

Creating a small system

When you install the system software on a floppy disk, the Installer automatically creates the smallest practical System Folder. This allows the maximum room on your startup disks for application programs and your own work.

You can also create this small system by selecting the “Minimal software” option for your Macintosh model from the Customize dialog box of the Installer.

If you didn't originally install the minimum-sized system or you've added drivers, fonts, or desk accessories since installation, you can remove items that aren't essential. You remove drivers by dragging them out of the System Folder; you remove fonts and desk accessories with the Font/DA Mover.

Depending on the devices connected to your Macintosh, you should consider removing these items:

- drivers for printers or other devices you don't use (such as ImageWriter, AppleTalk ImageWriter, LaserWriter, LaserPrep)
 - networking drivers, if you are not on a network (such as AppleShare™)
 - extra desk accessories (you will definitely need the Control Panel, but you may not need the Alarm Clock, Calculator, Chooser, Find File, Key Caps, or Scrapbook)
 - extra fonts you have installed
- See also:
- “Creating a Customized System” in this chapter
 - “Making an Extra Startup Disk” in this chapter
 - “Moving Fonts and Desk Accessories” in Chapter 8

Updating to a new version of system software

If you have been using an older version of the system software and you get a newer version, you can update your system by installing the newer software.

To accommodate all Macintosh models, the system software upgrade is supplied on four 800K disks instead of the two 1.4 MB system disks provided with new computers.

To install the new system software, follow the instructions in “Installing System Software” or “Creating a Customized System” earlier in this chapter.

Installing 32-Bit QuickDraw for enhanced color images

If your Macintosh can display color images, you can enhance the computer's color capabilities by placing the 32-Bit QuickDraw™ file in the System Folder of your startup disk.

The 32-Bit QuickDraw file is provided in the Apple Color folder on the *System Additions* disk. (If you are updating your system software with an upgrade kit, you'll find the Apple Colour folder on the *Printing Tools* disk.)



1 To install 32-Bit QuickDraw, first locate its icon in the Apple Colour folder.

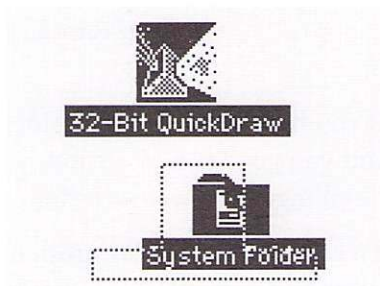

2 Drag the 32-Bit QuickDraw icon to the System Folder of the startup disk.

32-bit QuickDraw is copied into your System Folder.



3 Restart your system by choosing Restart from the Special menu.

The capabilities of 32-bit QuickDraw are in effect once you restart.

➤ *See also:* • "Specifying the Number of Colors or Shades of Grey" in Chapter 8

Starting up the Macintosh

If your Macintosh has a hard disk that's a startup disk, you simply turn on the computer to start up. If you're using a floppy startup disk, place the disk in the internal disk drive and turn on the Macintosh. To restart with a floppy disk, reinsert the disk after it is ejected.

- *See also:*
- "Installing System Software" in this chapter
 - "Creating a Customized System" in this chapter
 - "Turning the Macintosh On and Off" in Chapter 2
 - "Inserting a Disk" in Chapter 6

Specifying items to be opened at startup

You can designate one or more application programs, desk accessories, and documents to be opened automatically when you start up the Macintosh. To specify items for opening at startup, you use the dialog box that appears when you choose the Set Startup command from the Special menu. (See Figure 2-3.)

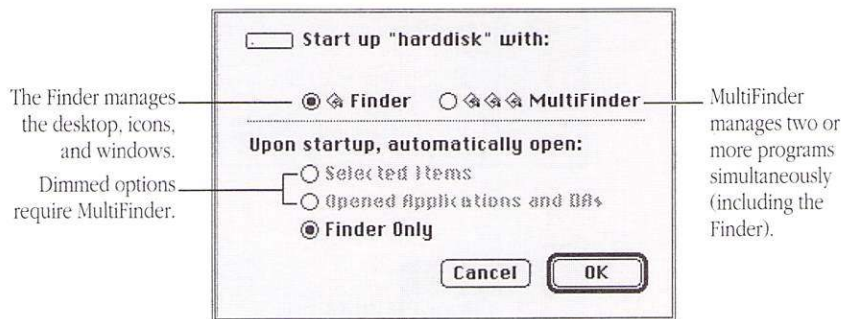

Figure 2-3 The Set Startup dialog box

The procedure for using the Set Startup command varies somewhat according to the number and type of items you want to open at startup.

Table 2-1, at the end of the instructions for "Selecting Multiple Startup Items," summarizes the procedures for opening programs, documents, and desk accessories at startup.

Selecting one startup program or document

Whether you use the Finder™ or the MultiFinder option, you can easily specify a program or document for opening at startup.



1 To specify a program or document for opening at startup, first select its icon by clicking.



2 Choose Set Startup from the Special menu.

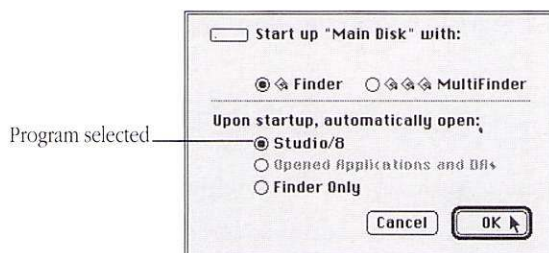

3 Check that the program or document you selected is shown, then click OK.

Changing from Finder to MultiFinder or vice versa will not affect your selection of a startup program or document.



4 Choose Restart from the Special menu.

The program or document you selected is opened when the Macintosh restarts.

Your startup selection remains in effect until you change it with the Set Startup command.

Selecting multiple startup items

To open more than one item at startup, you must use MultiFinder, the system file that permits the Macintosh to work with two or more programs simultaneously. You use the Set Startup command to turn on MultiFinder, as well as to specify the startup items.

Until you turn MultiFinder on, the Macintosh automatically uses the Finder, the system file that manages the desktop, windows, and icons. (You can still use the Finder when MultiFinder is turned on.)

The instructions that follow show how to select a group of items for opening at startup. Consult Table 2-1 for a summary of the procedures required to select several different types and combinations of startup items.

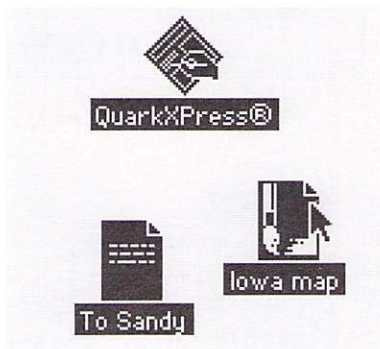

1 To specify multiple startup items, first select the programs and documents you want to have opened by Shift-clicking their icons.

All the items must be at the same level—on the desktop or in the same folder.

If you want to specify desk accessories as startup items, you must first turn on MultiFinder and then open the desk accessories.



2 Choose Set Startup from the Special menu.

The Set Startup dialog box opens.



3 If necessary, click the **MultiFinder** button to turn it on.

Skip this step if MultiFinder is already selected.

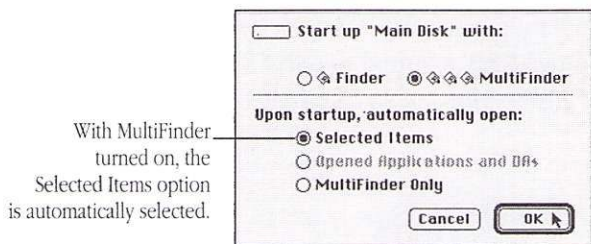

4 Check that the button labeled **"Selected Items"** is selected, then click **OK**.



5 Choose **Restart** from the **Special** menu.

The items you selected are opened when the Macintosh restarts.

Your startup selection remains in effect until you change it with the **Set Startup** command.

- *See also:*
- "Managing Multiple Programs Using MultiFinder" in Chapter 3
 - "Managing System Memory" in Chapter 3

Table 2-1 Summary of procedures for opening items at startup

To open at startup	Requires	Do before choosing Set Startup
1 application program	Finder or MultiFinder	Select program icon
2 or more programs	MultiFinder	Open or select program icons
1 or more desk accessories	MultiFinder turned on*	Open desk accessories
1 or more desk accessories plus 1 or more programs	MultiFinder turned on*	Open desk accessories and program icons
1 or more documents	MultiFinder	Select document icons
1 or more documents plus 1 or more application programs	MultiFinder	Select document icons and program icons
1 or more documents plus 1 or more desk accessories	Not possible	

*MultiFinder must already be in effect before you open any desk accessories to specify them as startup items.



Working With Application Programs

Application programs determine what kinds of work a Macintosh can do—such as writing, drawing, designing, calculating, controlling a variety of processes, and managing vast amounts of information.

This chapter outlines some fundamental operations common to all application programs, regardless of a program's specific purpose and product.

These operations include

- preparing to use an application program
- moving text and images within a document
- copying text and images from one document to another
- saving documents—under various names, in various locations
- storing frequently used text and images for easy access
- recognizing whether you're in a program or on the desktop and moving from one "place" to the other

This chapter also presents procedures for managing several application programs (often just called *programs* for simplicity) and summarizes the appropriate steps for ending a work session.

Preparing to use a program for your work

You use standard Macintosh operations to install and start most programs, and to create documents with them. Once you've created a document with a program, you can either start the program and then open the document, or simply open the document's icon on the desktop, which automatically starts the program.

Installing a program

In most instances, you install an application program by copying it from its original disk to your hard disk or to a floppy disk. (A few programs have more elaborate installation procedures.)



1 To install an application program, first open the program's disk by double-clicking its icon.

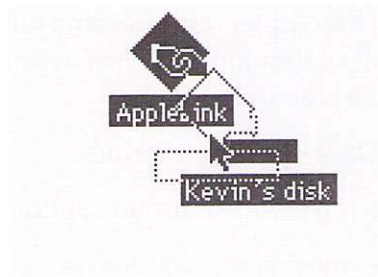

2 Copy the program by dragging its icon to the icon of your hard disk or startup floppy disk.

Release the mouse button when the disk's icon becomes highlighted. The program is then copied onto the disk. (You can also copy a program to a folder by dragging its icon to the folder icon, or copy the program to an open directory window by dragging its icon to the window.)

If your system has only one floppy disk drive, you'll have to swap disks several times.

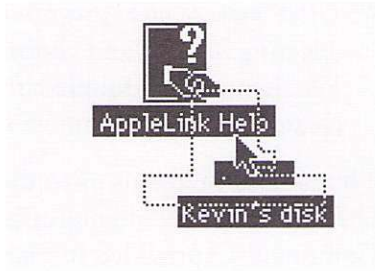

3 If necessary, copy any additional files the program needs by dragging their icons to the hard disk or to the startup floppy disk.

The program's documentation should specify whether any such files are needed.

It's a good idea to open the icon of the hard disk or the floppy disk to make sure that the program and other files were copied.

Consult the program's documentation to determine whether additional installation steps are necessary.

- *See also:*
- "Installing System Software" in Chapter 2
 - "Creating a Small System" in Chapter 2
 - "Making an Extra Startup Disk" in Chapter 2

Starting a program You start a program by opening it.



1 To start a program, first point to its icon.

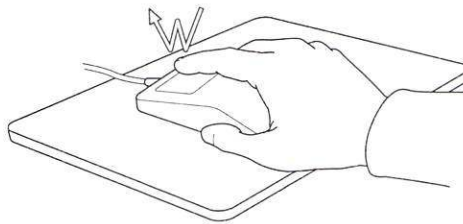

2 Double-click the mouse button to open the program.

The program's window appears, usually with a new, blank document displayed.

- ❖ *Other ways to open programs:* You can also open a program by selecting its icon and choosing the Open command from the File menu or by double-clicking the icon of a document created by the program. ❖

The program remains open until you quit, usually by choosing Quit from the File menu (or by using the keyboard shortcut Command-Q provided in many programs).

- *See also:*
- “Opening a Document on the Desktop” in this chapter
 - “Knowing Where You Are on the Macintosh” in this chapter

Creating a new document in a program

You create a new document while working in a program by choosing the New command.

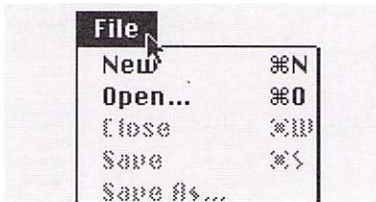

1 To create a new document in a program, first open the File menu.



2 Drag the pointer to the New command and release the mouse button.

The program opens a new document. If another document was already open, the new one covers it. (Some programs don't permit more than one open document at a time.)

Opening an existing document in a program

You open an existing document while working in a program with the Open command.

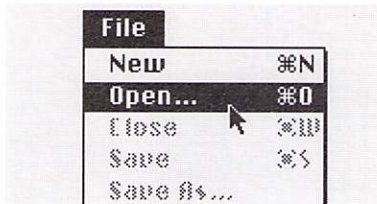

1 To open an existing document in a program, first choose Open from the File menu.

The program's directory dialog box appears, with a list of documents and folders on the disk in use.

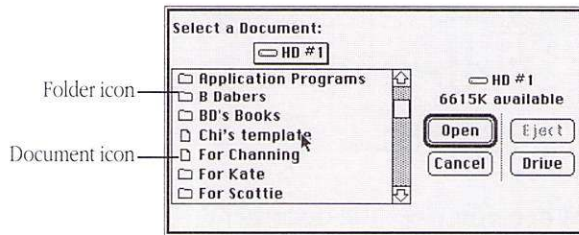

2 If necessary, scroll to locate the document, then click its name to select it.

You can display the documents in a folder by selecting the folder and clicking the Open button.

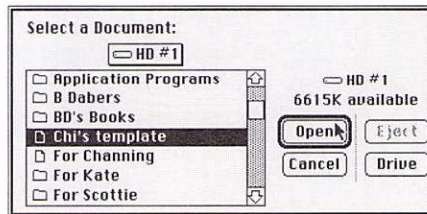

3 Click the Open button to open the selected document.

➤ See also: • “Knowing Where You Are on the Macintosh” in this chapter

If you are using the desktop rather than working in a program, you can open a document and start the program at the same time. (This technique may not work if the program is already open when you're using MultiFinder.)



1 To open a document on the desktop, first point to its icon.



2 Double-click the mouse button to open the document and simultaneously start the program.

The program starts, with the document open in its window.

When you close the document, the program stays open until you quit, usually by choosing Quit from the File menu (or by using the keyboard shortcut Command-Q).

- *See also:*
- “Knowing Where You Are on the Macintosh” in this chapter
 - “Managing Multiple Programs Using MultiFinder” in this chapter

The Macintosh computer's standard operations allow you to edit text and to copy both text and images between parts of a document, from one document to another within a program, and between documents in different programs.

Editing text You can use the standard text-editing operations available on the desktop when you're in a program. These include

- selecting text
- replacing text
- deleting text
- inserting text

If necessary, review the instructions in “Basic Editing on the Desktop” in Chapter 1 for instructions for basic text editing. You can also get practice editing in *Getting Started With Your Macintosh* and in *Macintosh Basics*, the training disk.

Copying text and images You can easily copy selected text and images.

Many graphics programs identify a selected item with a moving dashed outline.

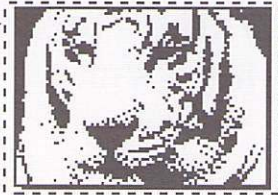

1 To copy text and images, first select the item you want to copy.

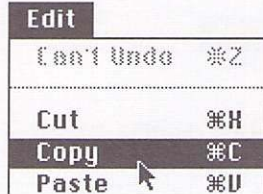

2 Choose Copy from the Edit menu.

Your selection is copied and stored in a part of the computer's memory called the Clipboard until you copy or delete another item or you turn off the computer.

- ❖ *A keyboard shortcut for copying:* You can also use the keyboard shortcut Command-C to copy selected items. ❖
- ❖ *To check the Clipboard:* You can see the current contents of the Clipboard by choosing the Show Clipboard command from the Edit menu. This command is available in some programs, and it's always available when you're working on the desktop. ❖

➤ *See also:* •“Deleting Text and Images” in this chapter

Inserting copied text and images within a document

Once you've copied text, images, or both, you can insert that material anywhere in an open document.

Insertion point



White Tiger
Has Twins!

1 To insert text and images in a document, first click at the exact spot where you want the item to appear.

A blinking insertion point appears at the spot where you click.

2 Choose Paste from the Edit menu.

The item you copied previously is inserted.

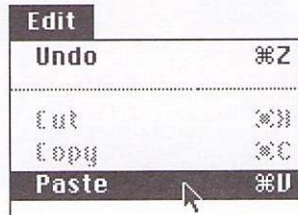



White Tiger Has Twins!

3 Check the document to make sure that the copied item was inserted as you want it.

You can paste the copied item as many times as you wish.

- ❖ *Pasting shortcut:* You can also use the keyboard shortcut Command-V to paste copied material into a document. ❖

Copying text and images between documents in different programs

You can easily copy text and images from one document to another in the same program or from a document in one program to a document in another program. The instructions that follow cover the slightly more complicated task of copying between documents in two different programs.

A moving dashed outline indicates a selected item in many graphics programs

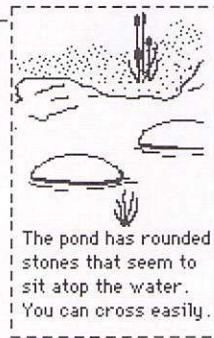

1 To copy an item between documents in different programs, first select the desired material from a document in the first program.

In a graphics program, a selection is often marked by a moving dashed outline; in a text program, a selection is highlighted.

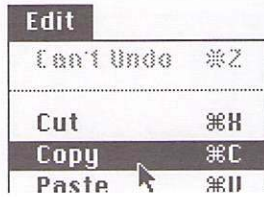

2 Choose Copy from the Edit menu.

The selection is copied to the Clipboard.

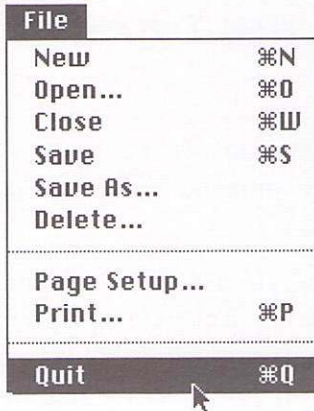

3 Choose Quit from the File menu to leave the first program.

If you're using MultiFinder, you don't have to quit the first program; you can simply switch to the Finder or to the second program if it's already open.



4 Double-click the icon of the document into which you want to paste the item you copied.

Opening the document automatically starts the program.

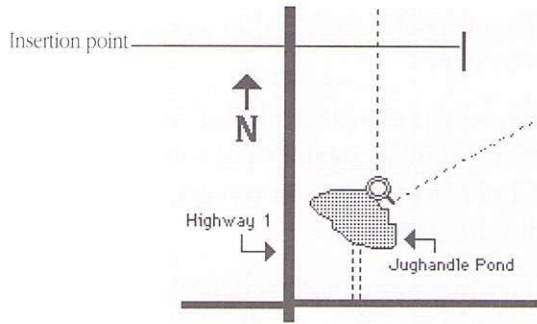

5 Click at the exact spot where you want the item to appear in the document just opened.

A blinking insertion point appears at the spot where you clicked.

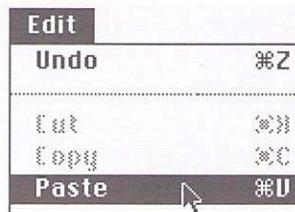

6 Choose Paste from the Edit menu.

The selected item appears at the insertion point.

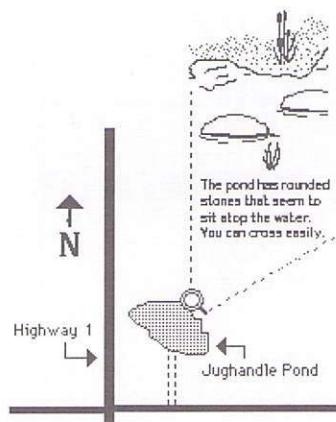

7 Check the screen to be sure that the copied material was pasted where you want it.

You can always delete the pasted item, select another insertion point, then paste again.

If you are not making other changes in this document, save and close it.

- *See also:*
- “Switching Programs or Desk Accessories With MultiFinder” in this chapter
 - “Starting a New Program When Using MultiFinder” in this chapter

Deleting text and images

You can delete text and images from a document in either of two ways.

One method, using the Cut command, places the deleted material in an area of the computer's memory called the Clipboard so that you can get it back (until you copy or cut another item).

The second method, using the Clear command, removes the material and does not place it on the Clipboard.

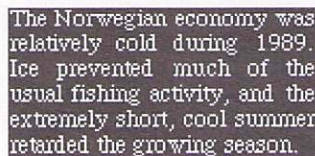

The Norwegian economy was relatively cold during 1989. Ice prevented much of the usual fishing activity, and the extremely short, cool summer retarded the growing season.

The outlook is much brighter for the 1990s in Norway. New manufacturing centers have been constructed, more

1 To delete text or images, first select the item to be removed.

The selection becomes highlighted (if it's text) or enclosed by a moving dashed outline (if it's graphics).

2 Choose Cut or Clear from the Edit menu.

The selected item disappears from the screen.

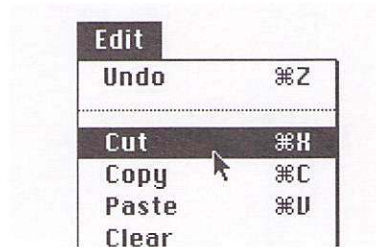

❖ *Another way to clear text and images:* Pressing the Delete key also clears selected material. ❖

Canceling an editing action

You can cancel many editing actions with the Undo command, which reverses your most recent action (if it is possible to reverse that action).

The actions that you can undo with this command vary among programs.

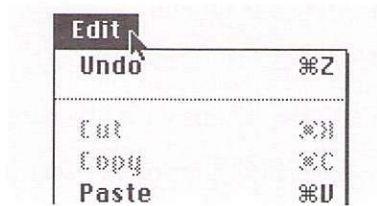

1 To undo an action, first open the Edit menu to see if the Undo command is available.

The command is black if available; it is dimmed and sometimes reads “Can’t undo” if it can’t be used to reverse your most recent action.

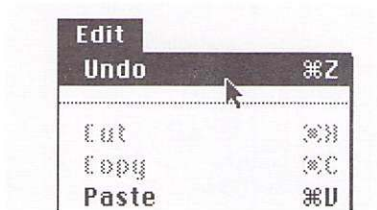

2 If Undo is available, drag to it and release the mouse button.

The Undo command reverses your previous action. Choosing Undo a second time restores your original action.

- ❖ *Shortcut for Undo:* You can use the keyboard shortcut Command-Z to initiate the Undo command. ❖

Saving documents

Saving your work often is the best safeguard against lost data. Macintosh programs offer several ways to save documents, providing great flexibility in managing and storing your work.

When you save, you can

- name the document
- change its name
- change its location
- save revisions with no change in name or location
- save all or part of a document in the Scrapbook desk accessory for access any time

Most saving options use a form of the directory dialog box, in which you name a document and select its storage location. (See Figure 3-1.)

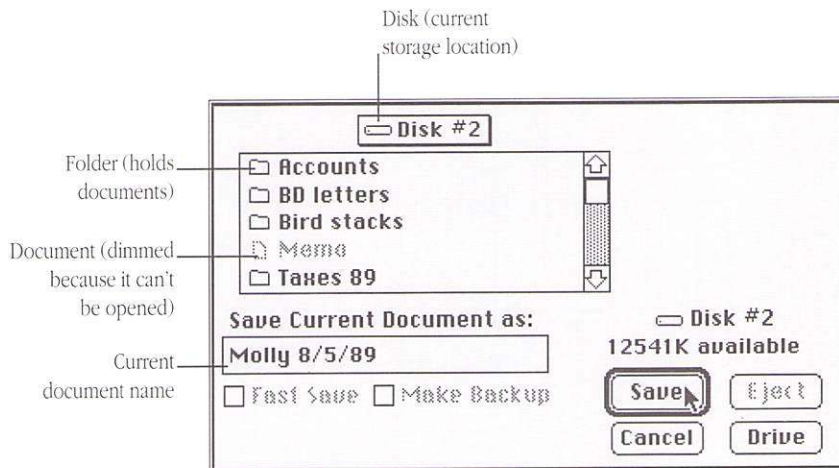
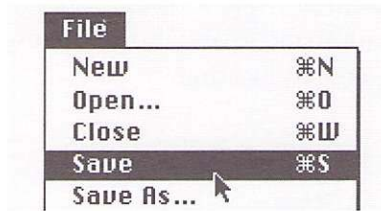

Figure 3-1 A directory dialog box for saving files

Saving a new document

When you create a new document and save it for the first time, you must name it.

When a document has not yet been named, the directory dialog box automatically appears when you choose the Save command. This dialog box also appears when you choose the Save As command.



1 To save a new document, first choose Save from the File menu.

The directory dialog box opens. An insertion point is blinking in the name box.

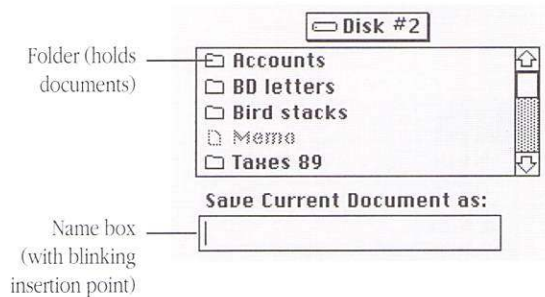

2 Type a name for the document.

If you make a typing error, you can use the Delete key to backspace, or you can drag across the part of the name to be corrected, and then retype.

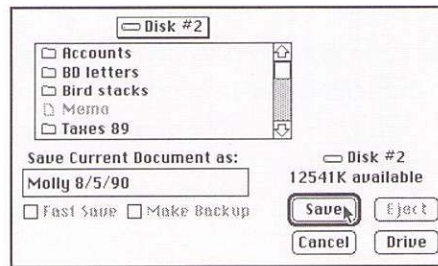

3 Click the Save button to save the document.

The program saves the document and the dialog box closes. The name of the document now appears in the window's title bar.

- ❖ *A different way to save:* Some software, such as HyperCard and many database programs, saves your document automatically after you make a change and when you close the document. In these programs, you name a document at the time you open it. ❖

Saving a revised document

When you make changes to a previously saved document, you can save your revisions quickly with the Save command. This command saves your revisions without changing the document's name or location.

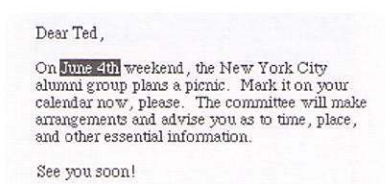

1 Make the revision to your document.

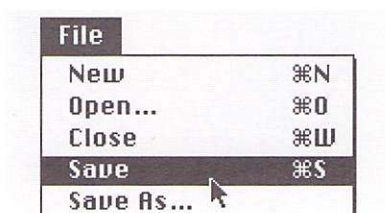

2 Choose Save from the File menu.

The pointer becomes a wristwatch while the document is being saved. (Some programs use a different icon.)

- ❖ *Save command shortcut:* You can save revisions most efficiently by using the keyboard shortcut Command-S, which is available in many programs. ❖

Saving a document under a new name

You can change the name of an existing document with the Save As command.

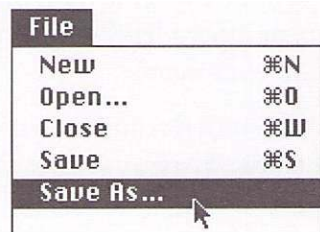

1 To save a document under a new name, first choose Save As from the File menu.

A directory dialog box opens, with the document's current name selected in the name box.

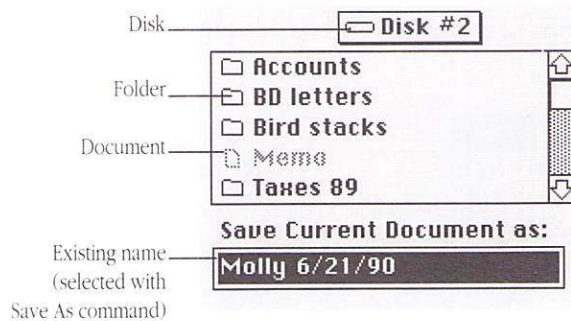

2 Type a new name for the document.

Your typing replaces the selected name. If you make a typing error, you can use the Delete key to backspace, or you can drag across the part of the name to be corrected, and then retype.

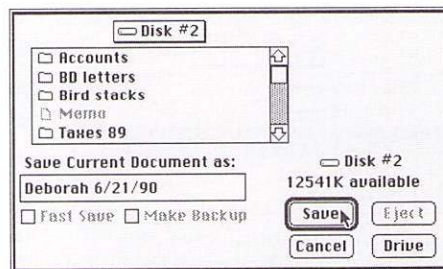

3 Click the Save button to save the document under its new name.

The document is saved and the dialog box closes. The new document's name appears at the top of the active window.

❖ *Return key shortcut:* You can press Return instead of clicking the Save button. (Pressing Return initiates the action for the button with a bold outline.) ❖

When you save with a new name, the original document (with its original name) remains intact, in the version you last saved before changing the name. To avoid confusion with different versions of a document, it's a good idea to include a number, date, or other identifying element whenever you change a document's name.

To rename a document without retaining a version under the old name, change its name on the desktop.

- *See also:*
- “Renaming a Document” in Chapter 5
 - “Basic Editing on the Desktop” in Chapter 1

Saving a second copy of a document under the same name on a single disk

You can make two copies of a document with the same name by placing them in different locations on the disk.

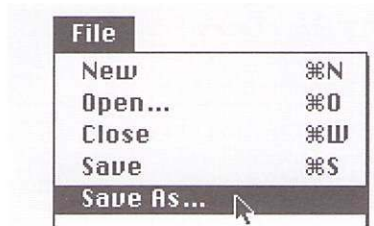

1 To save a second copy of a document under the same name, first choose **Save As** from the **File** menu.

The directory dialog box opens, with the document's current name selected.

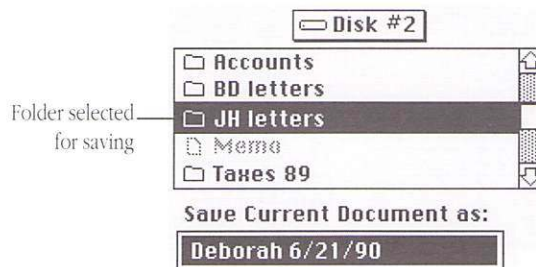

2 If necessary, scroll to locate the folder in which you want to save the second copy of your document, then click the folder's name and click the **Save** button to open the folder.

The folder opens, and a list of the folder's contents is displayed.

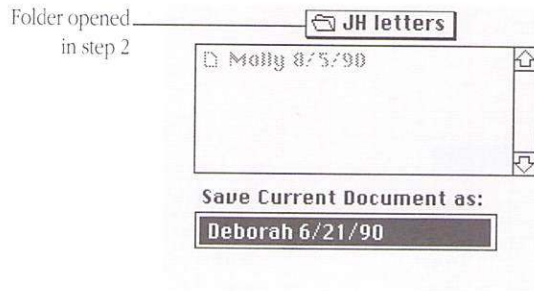

3 Click the Save button again to save the document in the open folder.

The dialog box closes as the program saves the document.

If you open a folder that already contains a document with the same name as the one you're saving, you'll see a message alerting you that the version you're saving will replace the one already there. (See Figure 3-2.)

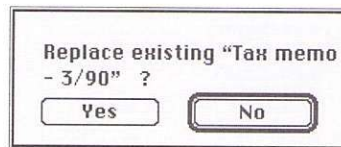

Figure 3-2 Alert box to confirm replacing old version with new

You can avoid replacing the old version by clicking No. Clicking Yes replaces the old version with the new one.

- *See also:*
- “Copying a Document on the Same Disk” in Chapter 5
 - “Using Folders to Organize Your Work” in Chapter 5

Saving a document onto a different disk

You can easily change the disk on which you plan to store a document.

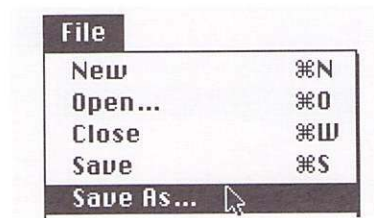

1 To save a document on a different disk, first choose **Save As** from the **File** menu.

The directory dialog box opens, with the document's name selected.



2 Click the **Drive** button to display the name of a different disk.

If you are using floppy disks, you may have to eject a disk—using the **Eject** button—and then insert the desired disk.

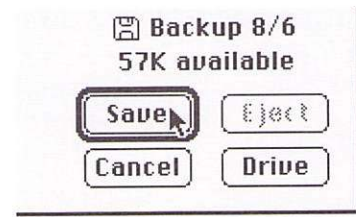

3 If necessary, select a new location by double-clicking the folder where you want to save the document, then click **Save**.

The program saves the document and the dialog box closes. The newly saved document becomes the active version (that is, you are now working on a different disk, and your changes will be saved there).

If you try to save a document on a disk or in a folder that already contains a document with the same name, you'll see a message alerting you that the version you're saving will replace the one already there. (See Figure 3-2.)

You can avoid replacing the old version by clicking No. Clicking Yes replaces the old version with the new one.

Saving text and images in the Scrapbook for easy access

The Scrapbook desk accessory provides an excellent storage place for text and images you use frequently. The Scrapbook is automatically included when you install system software. (See Figure 3-3.)

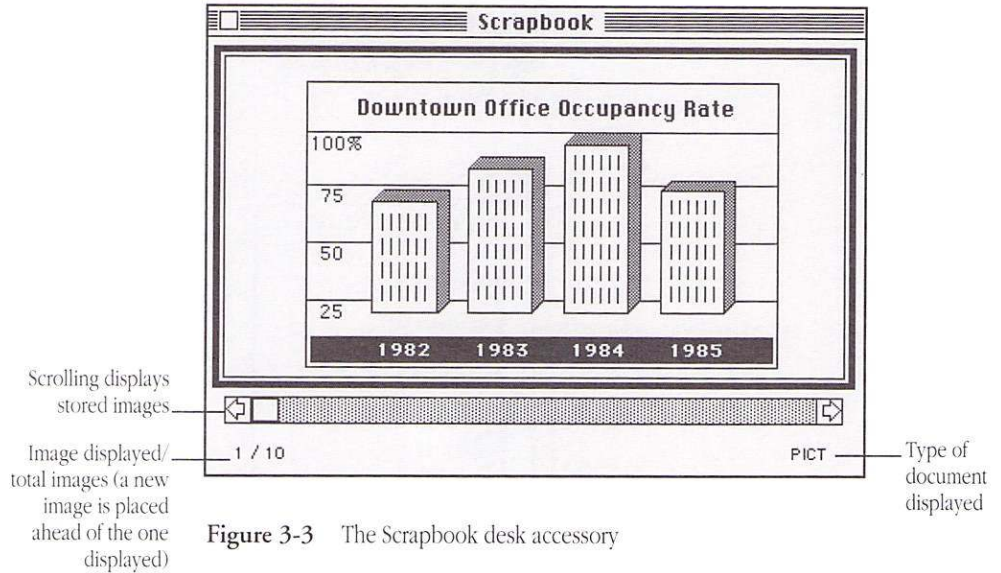
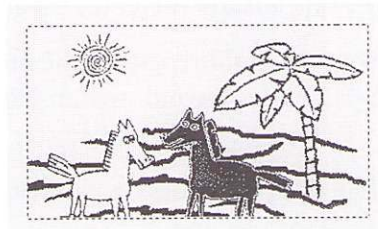
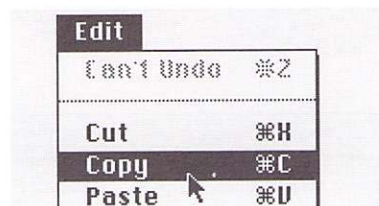

Figure 3-3 The Scrapbook desk accessory

When the Scrapbook is open, the standard editing commands Cut, Copy, and Clear operate on the contents of its window.



1 To put text or images in the Scrapbook, first select the material you want to copy.



2 Choose Copy from the Edit menu.

The selection is copied onto the Clipboard in the computer's memory.



3 Choose Scrapbook from the Apple menu.

The Scrapbook window opens, displaying the first item in it.

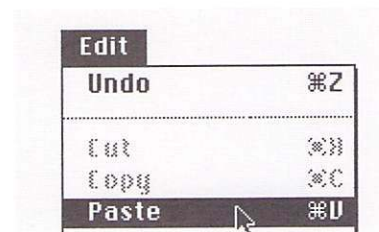

4 Choose Paste from the Edit menu.

The selection is pasted in front of the item previously displayed in the Scrapbook, and the number of items is adjusted to reflect the addition.

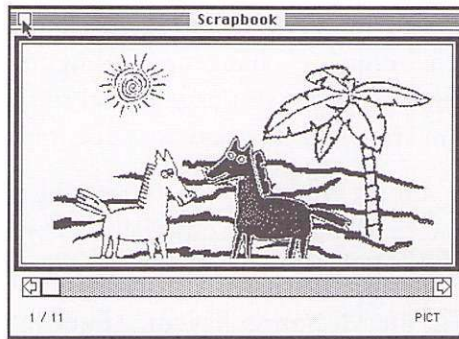

5 Close the Scrapbook by clicking its close box.

- ❖ *Copy and Paste command shortcuts:* You can use keyboard shortcuts to copy and paste—Command-C for copy, Command-V for paste. ❖

Editing operations in the Scrapbook include

- Cut—delete the item displayed and store it on the Clipboard (see “Copying Text and Images” earlier in this chapter)
- Copy—copy the item displayed and store it on the Clipboard (for pasting into desired document)
- Clear—delete the item displayed

You can create more than one version of the Scrapbook, but the system can only work with one such file at a time. If you maintain several scrapbook files, be sure to store them under different names so that you don’t inadvertently replace one of them with the content of another.

To swap Scrapbook files,

- remove the current Scrapbook File from the System Folder and give it a different name
- then rename the file you want to substitute “Scrapbook File,” and place it in the System Folder

Knowing where you are on the Macintosh

When you work with programs and documents, the screen's "environment" changes according to the type of program you're using. At times you may look at the screen and wonder where you are—in a program, in a document, or on the desktop.

If you use MultiFinder, recognizing where you are from what you're seeing can be especially tricky, because you can see parts of the desktop even when you're using a program.

But the Macintosh has some built-in clues to help you determine where you are. The figures that follow show some easy ways to get your bearings.

Figure 3-4 shows the menu bar of an otherwise blank screen.

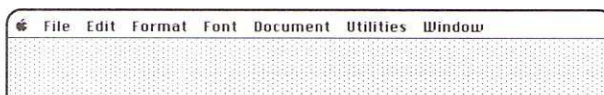

Figure 3-4 Only the menu bar is showing on the screen

Figure 3-5 shows how to determine where you are.

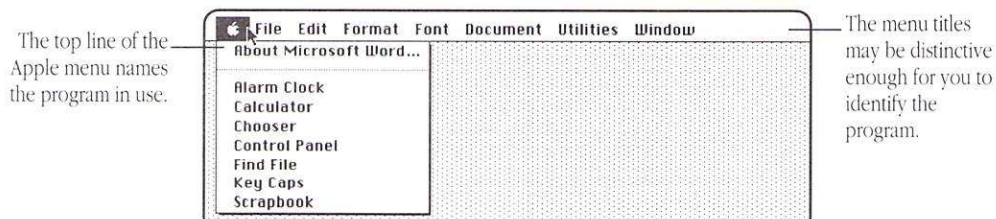

Figure 3-5 The menu bar's clues to what program you're in

Figure 3-6 shows assorted windows and icons when using MultiFinder.

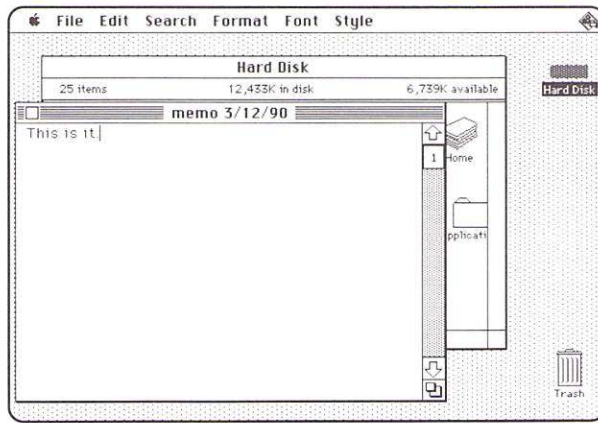

Figure 3-6 Screen with program and desktop windows open

Figure 3-7 shows how to see where you are and what else is open.

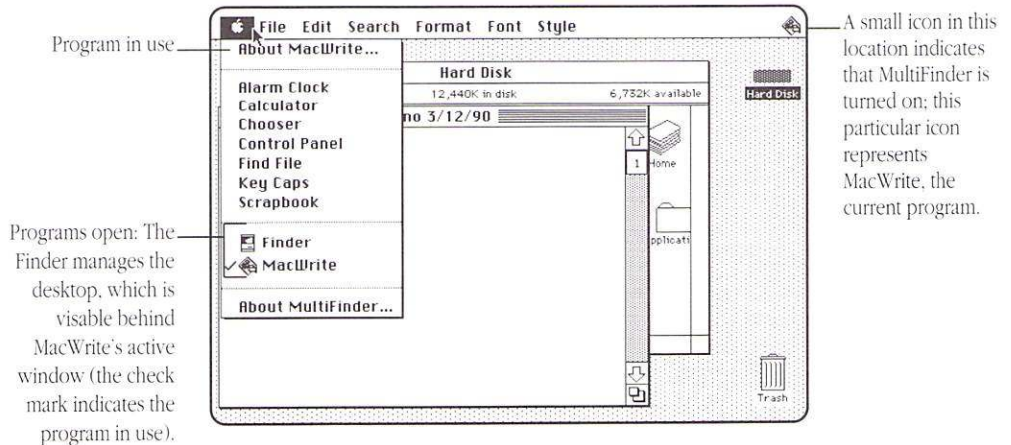
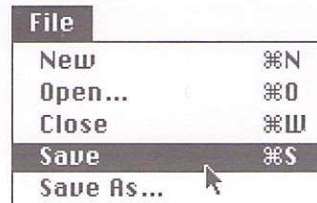

Figure 3-7 Clues to the programs open and the one currently active

➤ See also: • “Managing Multiple Programs Using MultiFinder” in this chapter

Returning to the desktop from a program

To return to the desktop when you're using a program (and MultiFinder is not turned on), save your work and quit the program.



1 To return to the desktop from a program, first save any new work in the open windows by choosing **Save** from the File menu.

Most programs warn you if you try to close a window or quit the program without saving your work.

You can also close the open windows after saving. If you don't, the program will close them when you quit.

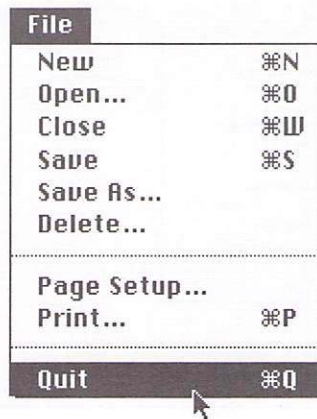

2 Choose **Quit** from the File menu.

The program's window and menu titles disappear and the desktop appears.

➤ *See also:* • “Managing Multiple Programs Using MultiFinder” in this chapter

Managing multiple programs using MultiFinder

Macintosh system software includes MultiFinder, which can open and manage multiple programs at the same time.

MultiFinder provides

- automatic opening of specified programs, documents, and desk accessories at startup
- quick and easy switching between open programs
- copying and pasting of text and graphics between documents in different programs, without having to close the documents or quit the programs
- continuous access to the desktop for starting new programs, moving or deleting documents, and changing floppy disks
- background printing

To make most efficient use of MultiFinder, you should also know how to manage your system's memory, discussed later in this chapter.

- *See also:*
- “Managing System Memory” in this chapter
 - “Specifying Items to Be Opened at Startup” in Chapter 2
 - “Using Background Printing” in Chapter 4

Turning MultiFinder on You turn MultiFinder on with the Set Startup command, which provides several options once MultiFinder is selected. (See Figure 3-8.)

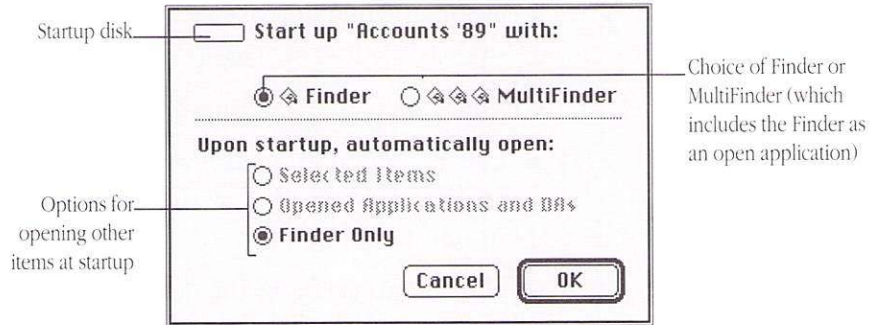
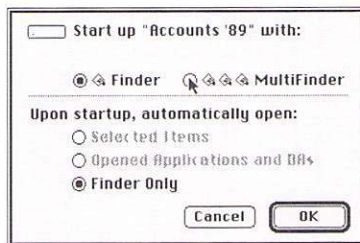

Figure 3-8 Set Startup dialog box with the Finder selected



1 To turn MultiFinder on, choose Set Startup from the Special menu.

The Set Startup dialog box opens.



2 Click the MultiFinder button.

The options in the lower part of the dialog box change when you click.

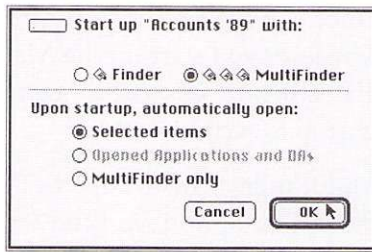

3 Click the OK button.
The dialog box closes.



4 Choose Restart from the Special menu.
MultiFinder takes effect when the Macintosh restarts.

You'll know that MultiFinder is in effect by the small icon displayed at the top-right corner of the menu bar. (See Figure 3-9.)

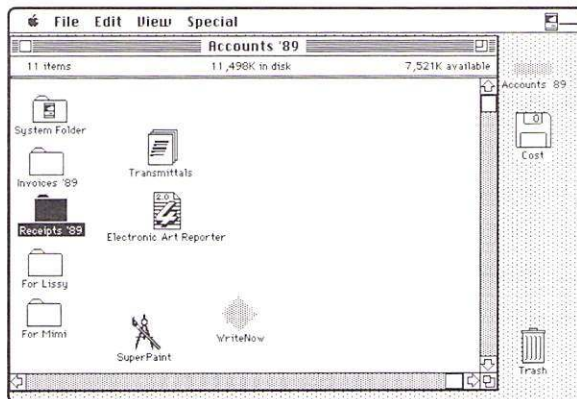

Active-application icon (indicates the application in use when MultiFinder is on)

Figure 3-9 Menu bar with active-application icon in top-right corner

Once you have turned on MultiFinder, it goes into effect whenever you start up the Macintosh. You use the Set Startup dialog box to specify programs and documents to be opened at startup as well.

MultiFinder remains in effect until you turn it off (by choosing the Finder option with the Set Startup command) and restart the computer.

➤ *See also:* • “Specifying Items to Be Opened at Startup” in Chapter 2

Switching programs or desk accessories with MultiFinder

You switch between open programs or desk accessories simply by clicking the active-application icon in the right corner of the menu bar. (See Figure 3-9.)

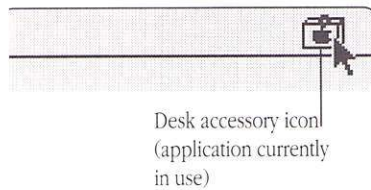

1 To switch programs or desk accessories, click the active-application icon.

The icon changes and a different program or desk accessory appears in the active window.

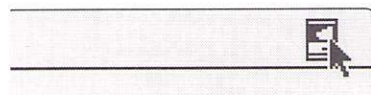

2 If necessary, click the active-application icon several more times, until the program or desk accessory you want is visible.

❖ *Other ways to switch programs:* You can also click in a document window or choose the name of an active program from the Apple menu to change programs. ❖

Starting a new program when using MultiFinder

When MultiFinder is in effect, you can start a program that is not currently open by opening it from the desktop.

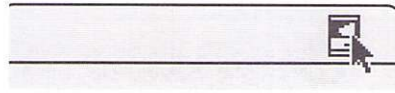

1 To open a new program, click the active-application icon until the small Macintosh appears.

The small Macintosh icon indicates the Finder, which manages the desktop. The window of the icon opened most recently on the desktop appears.



2 Locate the icon of the program you want and open it by double-clicking.

You may have to close or resize the windows of one or more documents if the icon you want is on the desktop and is hidden by them.

You'll see an alert box if there is not enough RAM for the new program to be opened. (See Figure 3-10.)

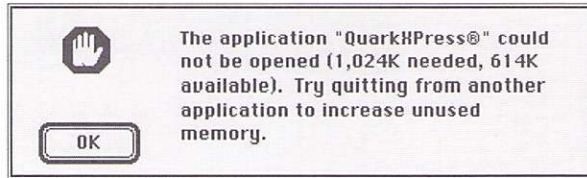

Figure 3-10 MultiFinder alert box reporting insufficient memory

❖ *Other desktop operations:* You can perform all the standard operations on the desktop when the Finder is the active program. ❖

➤ *See also:* • “MultiFinder’s Memory Requirements” in this chapter

Managing system memory

Occasionally you may have to make an adjustment in your use of the computer’s random-access memory (RAM) to continue working efficiently with large programs or with several programs open at once.

Becoming familiar with the amount of memory your Macintosh has and the memory requirements of the primary programs you use can help you take full advantage of the computer’s capabilities.

Multifinder's memory requirements

Your computer must have 1 megabyte (MB) of RAM to use MultiFinder. One megabyte usually allows you to open one program and one or more desk accessories, or two programs that are not too complex (and thus do not require a large amount of memory).

If you want to use two or more complex programs at the same time, your Macintosh probably should have at least 2 MB of RAM. Most Macintosh models can use 4 MB of system memory or more; consult the *Special Options and Technical Information* booklet for your model for its memory specifications.

Checking the amount of RAM in your Macintosh

You can check the amount of RAM in your system with the About the Finder command.

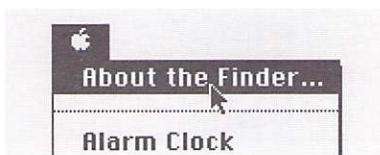

1 To check the RAM, choose About the Finder from the Apple menu while using the desktop.

The About window appears, displaying details about the Finder.

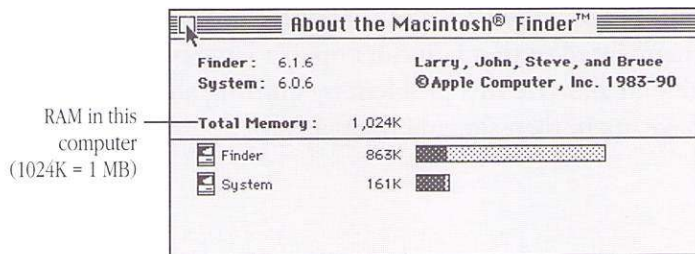

2 Click the close box to close the About window.

Consult your authorized Apple representative if you want to expand the RAM in your Macintosh.

Checking the RAM available for programs in MultiFinder

The Finder's About window also displays a graph depicting how much RAM is available for programs and how much memory each open program is currently using.

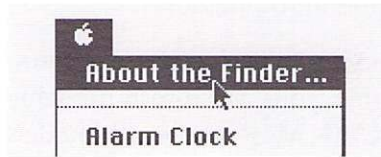

1 To find out how much RAM is available for programs, choose About the Finder from the Apple menu.

The About window opens, displaying a bar graph that indicates memory allocation.

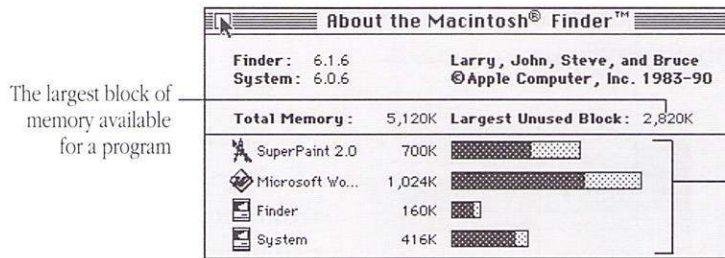

The largest block of memory available for a program

2 Click the close box to close the About window.

The bars show memory available for each open program; the dark areas show how much is currently in use.

Clearing system memory for efficient operation

If you're using MultiFinder and have opened and closed a number of programs, your Macintosh memory can become fragmented so that you can't open a large program. You may be able to alleviate this problem by quitting all the programs you have open, then starting them again.

Changing the memory allocation for a program

On rare occasions you may need to allocate additional memory for a program. You can do this by adjusting the program's memory size in the Get Info window.



1 To change the memory allocation for a program, first click the program's icon to select it.

The program must not be in use when you reallocate memory.



2 Choose Get Info from the File menu.

The Info window appears.

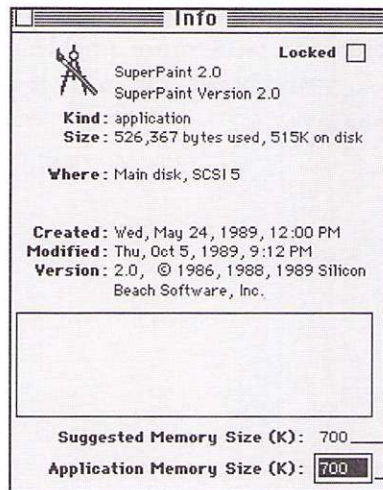

3 Drag across the number in the small box at the bottom of the window to select it.

Program manufacturer's suggested memory size

Current memory allocation

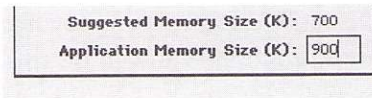

4 Type the new number for the memory you want to allocate.



5 Close the Info window to complete the allocation.

△ **Important:** Do not set the memory allocation for a program to a size that's smaller than the manufacturer's suggested size. This could cause the program to function improperly or not at all. △

Adjusting the RAM cache

The number of programs and desk accessories you can use at the same time in MultiFinder is also affected by the size of the RAM cache, if you are using it.

The RAM cache is a specified amount of memory that helps programs work more quickly and efficiently. The memory assigned to the RAM cache is not available to MultiFinder, however.

The maximum size of RAM cache depends on how much memory is available at a given time. If the available memory is less than the RAM cache size you have set, the system will temporarily reduce the RAM cache to the maximum allowable size.

To maximize MultiFinder's ability to handle multiple programs, turning off the RAM cache or setting it to a very small size—such as 32K—is advisable.

You set the RAM cache in the General Control Panel. (See Figure 3-11).

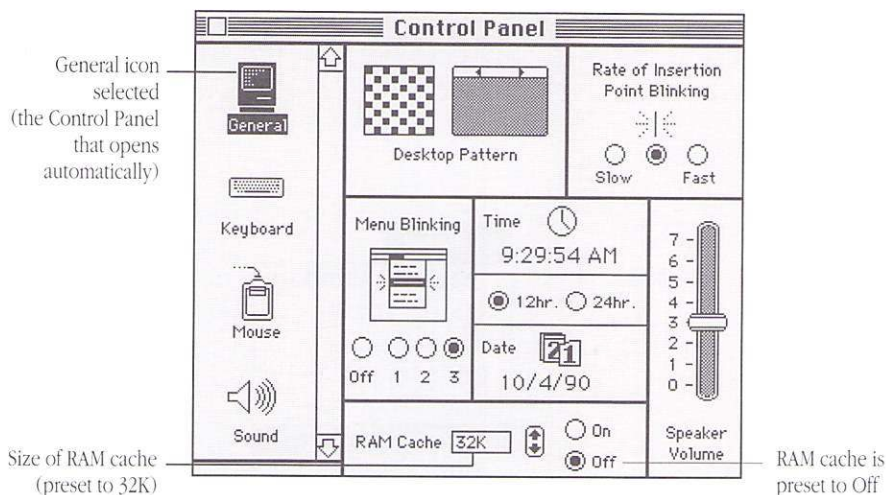
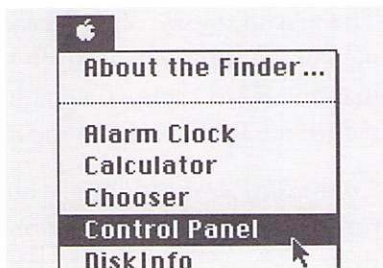

Figure 3-11 General Control Panel showing preset RAM cache status



1 To check the RAM cache, choose Control Panel from the Apple menu while on the desktop.

The General Control Panel appears.

Size increases or decreases in increments preset at the factory

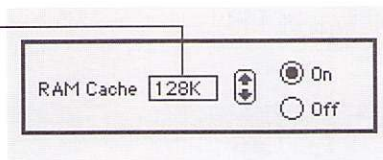

2 Click the up or down arrow to adjust the size of the RAM cache, or click Off to turn it off.

It's a good idea to close the Control Panel.



3 Choose Restart from the Special menu.

The adjusted RAM cache takes effect when the Macintosh restarts.

Ending a work session

When you've finished your work—with a program or for the day—it's a good idea to do some housekeeping before leaving the computer.

Quitting an application program

If you are finished using a program, use the Quit command to return to the desktop.

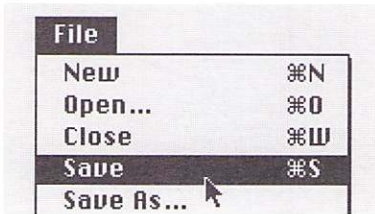

1 To quit, first save any work done since you last saved the current document.

Even though the program will prompt you to save if you try to quit before saving new work, it's good practice to save your work regularly, rather than relying on the program's safeguards.

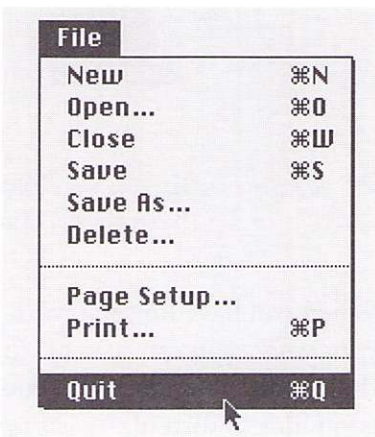

2 Choose Quit from the File menu.

Backing up the session's work

If you haven't made backup copies of your work as part of the saving process, be sure to copy any important documents you've revised during the session. The safest backup practice is to copy your work on a disk different from the one on which the original documents are stored.

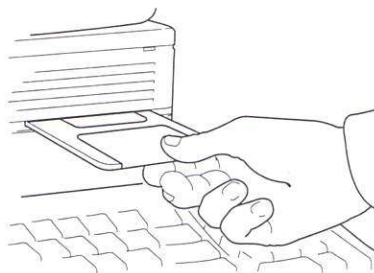

1 To back up your work, first insert a backup disk in one of the system's disk drives.

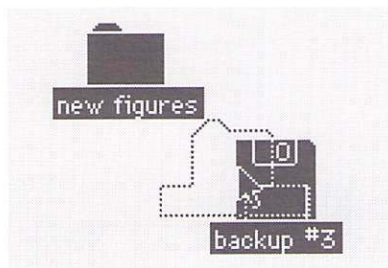

2 Copy the new files by dragging their icons to the icon of the backup disk.

You can back up on a hard disk, of course, but making separate copies of your work on floppy disks is advisable as well.

- *See also:*
- “Backing Up a Disk” in Chapter 6
 - “Backing Up a Hard Disk” in Chapter 6

Shutting down the computer

When you have finished work for the day and have backed up your work, you can turn off the Macintosh. (Many people leave their computers turned on continuously by preference; it's a good idea to turn off the computer if you will not be using it for a few days.)

The procedure for turning off the Macintosh varies somewhat depending on the model you use, but you should not simply turn off the power switch.

△ **Important:** Always use the Shut Down command before turning off your Macintosh. This command prepares the system software for shutdown. △



1 Choose Shut Down from the Special menu.

You'll see a message on the screen telling you that it's all right to turn off the switch.

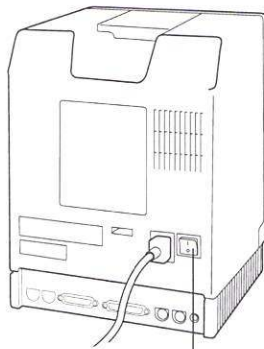

Power switch

2 If your model turns off with a switch, turn it off now.

Modular Macintosh models that are turned off by the Shut Down command can be turned on with the Power On key at the top of the keyboard.

- *See also:*
- “Using Special Keys and Indicators on the Keyboard” in Chapter 1
 - “Turning the Macintosh On and Off” in Chapter 1

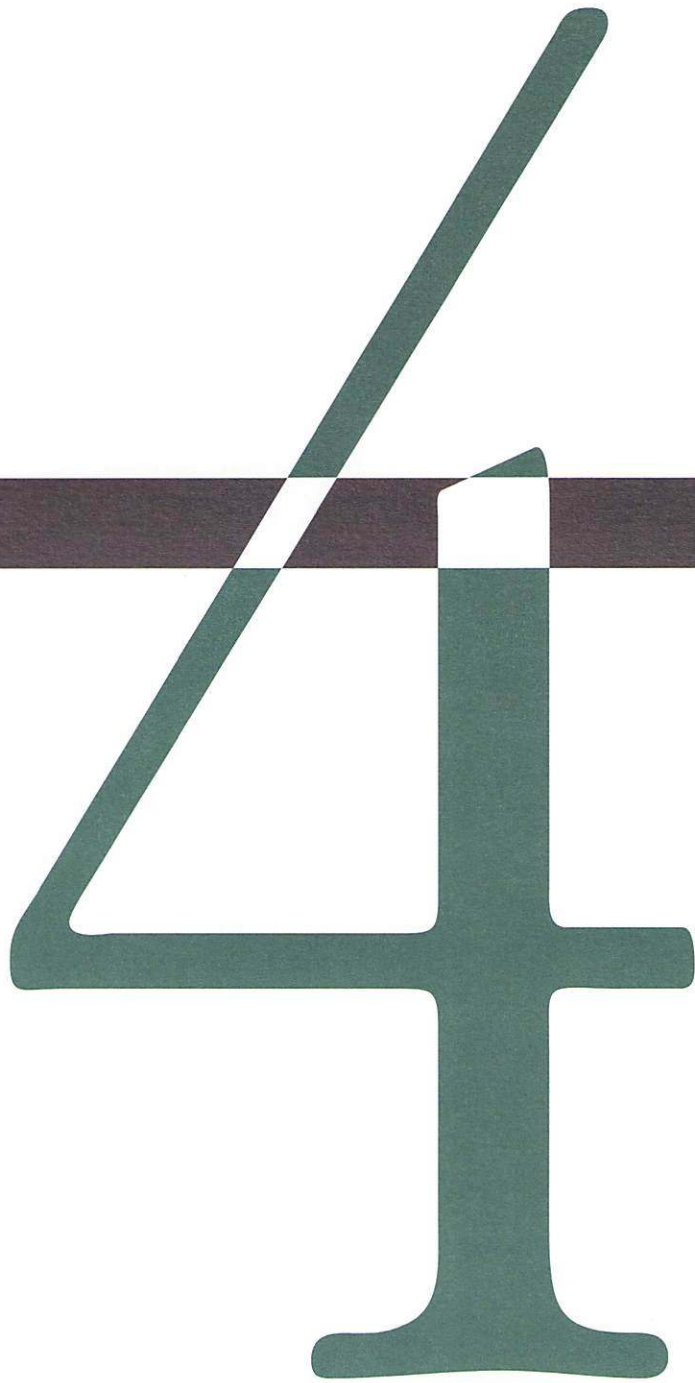

Printing Documents

The Macintosh provides several different ways to print documents, whether you are using a program or working on the desktop.

This chapter explains the preparations you make for printing, summarizes the options you can choose for paper, image size, and print quality, and presents brief instructions for each printing operation.







Getting ready to print

Before you can print a document, you must connect a printer to your Macintosh and prepare the system software to use the printer.

➤ *See also:* • “Connecting a Printer” in Chapter 9

Placing printer drivers in the System Folder

You must place a printer driver in your System Folder for each type of printer you want to use. Figure 4-1 shows the printer drivers provided with Macintosh system software.

	Connects directly	Connects via AppleTalk*
LaserWriter		  Laser Prep LaserWriter
LaserWriter SC	 Personal LaserWriter SC	
ImageWriter LQ	 LQ ImageWriter	 LQ AppleTalk ImageWriter
ImageWriter	 ImageWriter	 AppleTalk ImageWriter

*Cable in icon indicates connection to AppleTalk network.

Figure 4-1 Printer drivers supplied with system software

If you've installed the system software with the Installer, you can skip this procedure; the Installer's standard installation copies the printer drivers to the System Folder.

- ❖ *Color printing:* You must use a special version of the LaserWriter drivers to print with a color printer that is compatible with the LaserWriter. Instructions for using these drivers appear later in this chapter. ❖

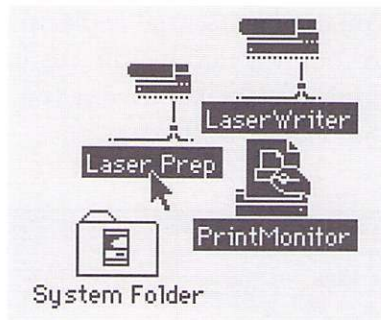

1 To put printer drivers in the System Folder, select the icon or icons for the printer drivers you need.

You'll find these drivers in the Printing folder or the *System Additions* disk. (If you are updating your system software with an upgrade kit, you'll find the printer drivers on the *Printing Tools* disk.)

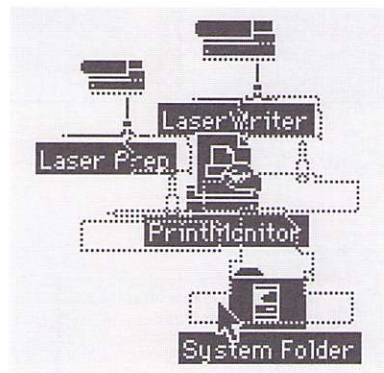

2 Drag the driver icons to the System Folder on your startup disk.

If you have multiple startup disks, repeat this process for each one.

➤ *See also:* • “Printing Color or Gray-Scale Documents” in this chapter

Choosing a printer

You can have several *output devices*, such as printers, connected to your Macintosh—directly or by network. You select the printers and other devices you want to use with the Chooser. (See Figure 4-2.)

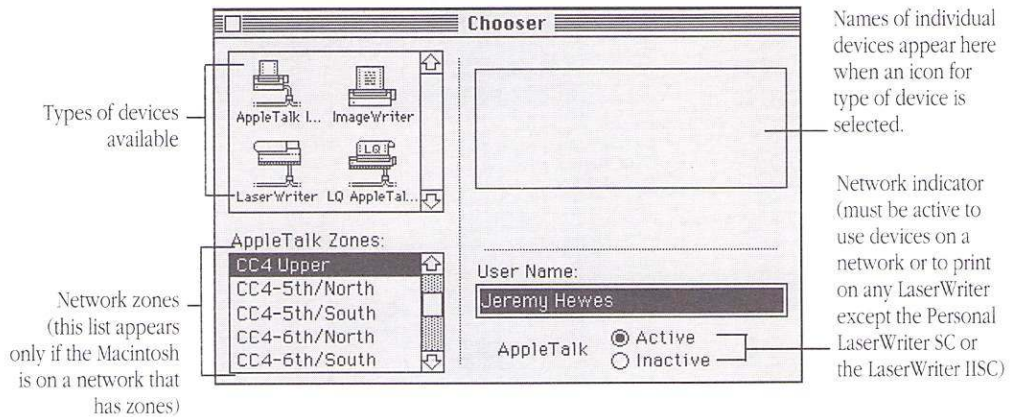
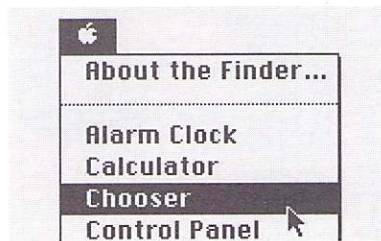
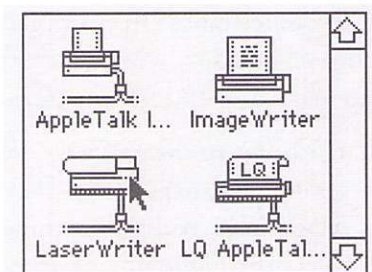

Figure 4-2 The Chooser



1 To designate a printer, select the Chooser in the Apple menu.

The Chooser window opens.



2 Click the icon for the type of printer you want to use from the upper-left area of the Chooser.

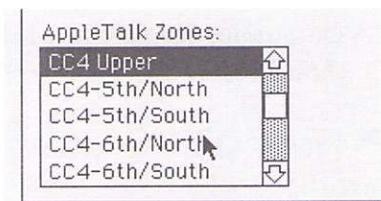

3 If necessary, select the network zone in which you want to choose a printer in the bottom-left area.

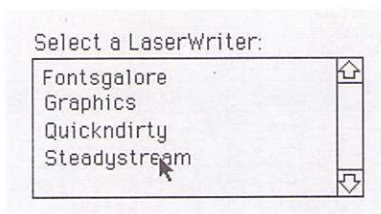

4 Select the name of the printer you want to use in the top-right area of the Chooser.

Your choice takes effect immediately. It's a good idea to close the Chooser window when you've chosen a printer (although you can leave it open if you prefer).

- ❖ *Choosing an ImageWriter:* When you use the Chooser to choose an ImageWriter that is connected directly to your Macintosh, you follow the steps above, except that you don't select the name of a printer. Instead, you specify which of the computer's two connection areas, called *ports*, the printer uses. The Chooser displays a dialog box in which you select the icon for the port to which your ImageWriter is connected. ❖

➤ *See also:* • "Connecting a Printer" in Chapter 9

Selecting Page Setup options

The Page Setup dialog box provides a number of choices for paper size and printing enhancements.

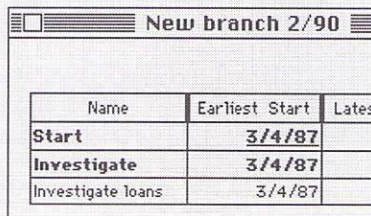

Name	Earliest Start	Lates
Start	3/4/87	
Investigate	3/4/87	
Investigate loans	3/4/87	

1 First, prepare the document you want to print.

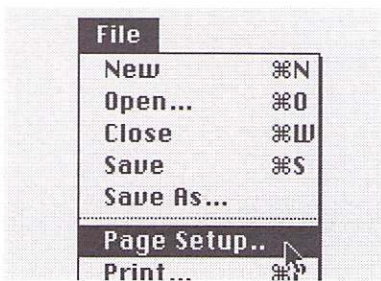

2 To select Page Setup options, choose Page Setup from the File menu.

The preset choices (or those selected most recently) are displayed when the dialog box opens.

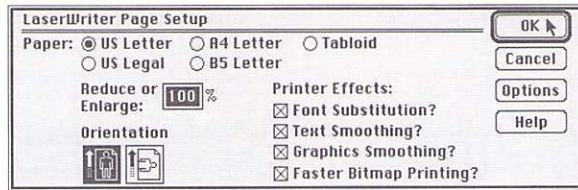

3 Select the paper size and printing enhancements you want and click OK.

Figure 4-3 shows the Page Setup options for the LaserWriter.

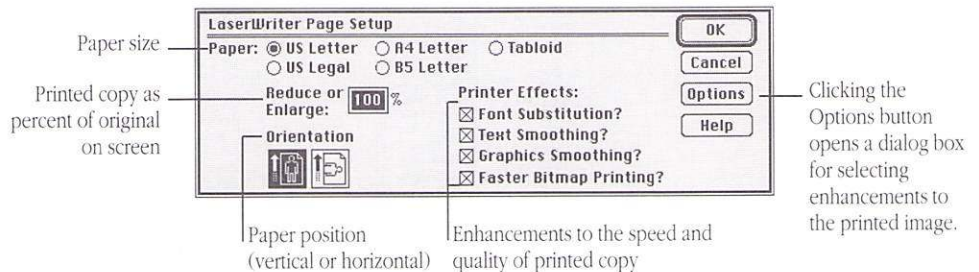

Figure 4-3 Page Setup dialog box for the LaserWriter

The enhancements provided in the Options dialog box include

- a flipped image (vertical or horizontal)
- an inverted image (black-white reversal)
- alignment of bit-mapped areas (provides greater image resolution but reduces the image by 4 percent)
- a larger print area (which uses more printer memory and therefore limits the number of downloadable fonts)
- unlimited downloadable fonts

(Downloadable fonts are type styles stored separately from the printer and transmitted to it at the time of printing.)

Figure 4-4 shows the Page Setup options for the ImageWriter.

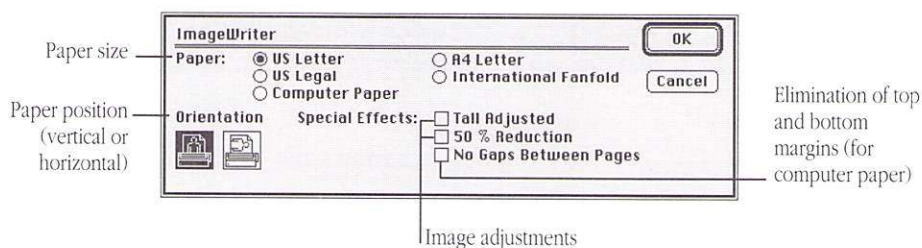

Figure 4-4 Page Setup dialog box for the ImageWriter

The ImageWriter LQ provides two additional choices: paper size includes a #10 envelope, and images can be reduced to 33 percent and 66 percent of original size.

You'll see different options for each type of printer you use. Some programs provide additional options in their version of Page Setup.

Selections made in the Page Setup dialog box remain in effect until you change them.

Printing your work

Printing while using an application program is probably the most common method, but the Macintosh also lets you print one or more documents from the desktop. In addition, you can print documents on any color printer that can use the LaserWriter drivers.

Wherever you initiate printing (by choosing the Print command from the File menu), you use the Print dialog box to specify printing options. Figure 4-5 shows the Print dialog box for the LaserWriter.

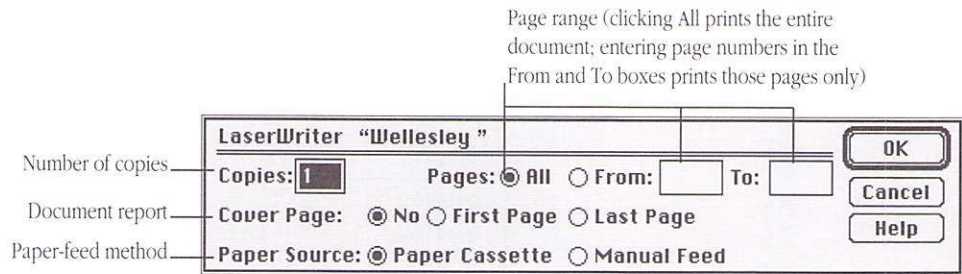

Figure 4-5 The Print dialog box for the LaserWriter

The ImageWriter models offer some different options for printing. These include

- print quality (best, faster, draft—a choice that affects printing speed as well as quality)
- bidirectional printing (ImageWriter LQ only)—the printing element prints continuously as it moves back and forth across the paper, making for very fast output
- cut sheet feeder use (ImageWriter LQ only)

Some programs offer additional printing options, such as printing from first to last page or from last to first page of a document.

Printing from within a program

You can easily print a document while working in a program's active window.

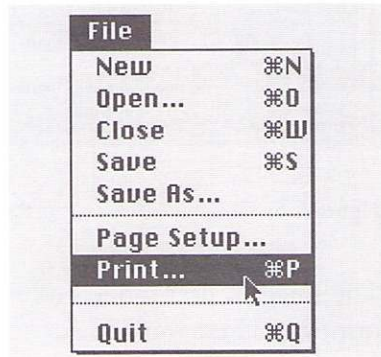

1 To print from within a program, choose Print from the File menu.

The Print dialog box appears.

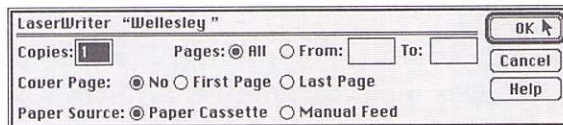

2 Select the options you want in the Print dialog box, then click OK.

After a moment, a status box appears and remains on the screen until printing is completed.

- ❖ *Keyboard shortcuts for printing:* You can use the keyboard shortcut Command-P to initiate printing in most programs, and you can press Return instead of clicking OK in the Print dialog box. ❖

Printing from the desktop

You can print one or more documents created in the same application program from the desktop—without starting the program first.

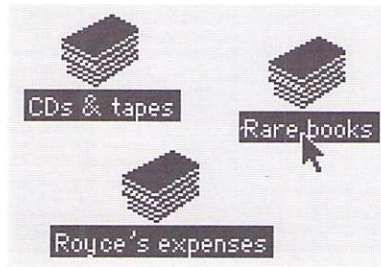

1 To print from the desktop, select the documents you want to print.

The group of documents must all be created by the same program and must reside on the desktop or in the same folder.

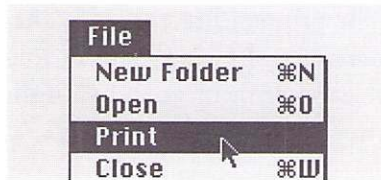

2 Choose Print from the File menu.

The program starts automatically after you choose the Print command; then the Print dialog box appears.

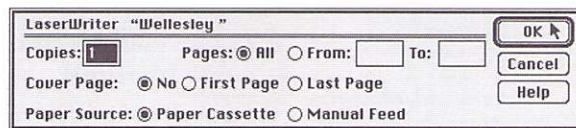

3 Select the options you want in the Print dialog box, then click OK.

The printing status box appears, remaining on the screen until printing is complete. The program closes, and you see the desktop again.

- ❖ *Return key shortcut for printing:* You can press Return instead of clicking OK in the Print dialog box. ❖

Printing a directory of disk or folder contents

You can print a directory of the files in the open window on the desktop. Figure 4-6 shows a directory arranged by the names of items in a folder.

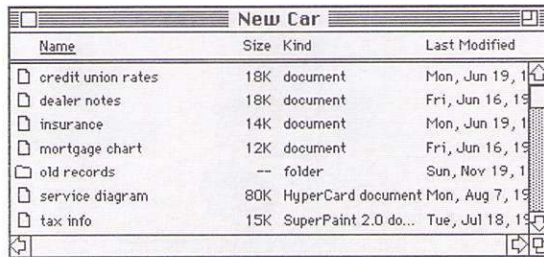
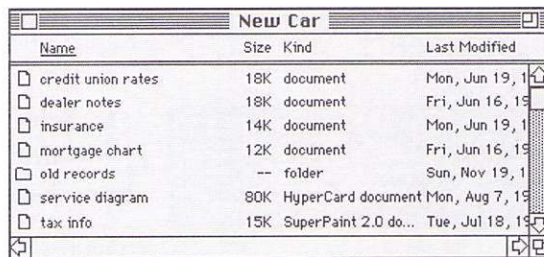
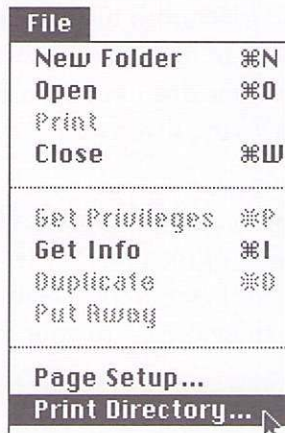

Figure 4-6 Directory arranged by name

The printed directory is a “snapshot” of the window’s entire contents, showing icons of folders and documents in their relative positions or a list of the items in the same order that they appear in the window.



1 Make sure that the directory you want to print is displayed in the active window on the desktop.



2 To print a directory, choose **Print Directory** from the **File** menu.

The **Print** dialog box opens.

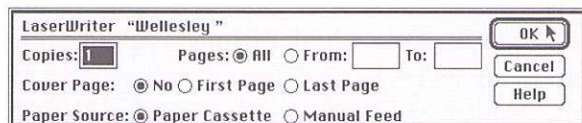

3 Select the options you want from the **Print** dialog box, then click **OK**.

The directory is printed in the format currently displayed.

❖ *Return key shortcut for printing:* You can press Return instead of clicking OK in the Print dialog box. ❖

➤ *See also:* • “Displaying Documents by Name, Size, Date, Kind, or Color of Icon” in Chapter 5

Color or gray-scale printing

Some Macintosh models can create and display documents in color or in multiple shades of gray (called *gray scale*). You can print these documents on any color printer that can use the LaserWriter drivers.

Installing the LaserWriter drivers for color or gray-scale printing

To print color or gray-scale documents, you must use special versions of the LaserWriter drivers; these files are version 6.0 (or later) of Laser Prep, version 6.0 (or later) of LaserWriter. You drag these drivers to your System Folder to install them.

Two sets of LaserWriter drivers are supplied as part of the system software with most Macintosh models; only those with version numbers 6.0 (or later) can be used for color printing. The drivers for color or gray-scale printing are on the *System Additions* disk, in a folder named "Apple Color." (If you are updating your system software with an upgrade kit, you'll find the Apple Color folder on the *Printing Tools* disk.

△ **Important:** If you use the 6.0 version of the LaserWriter drivers, make certain that everyone who uses the same printer you're using has installed the 6.0 drivers. Different driver versions will cause the printer to reinitialize frequently. △

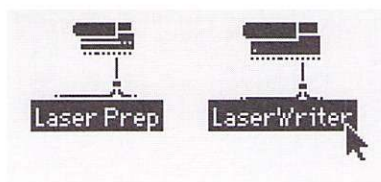

1 Select the icons for the LaserWriter drivers you plan to use for color printing.

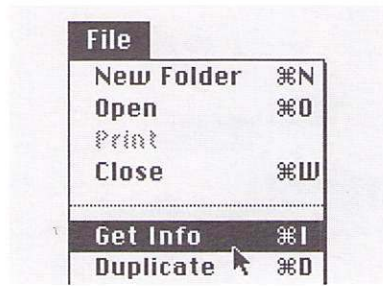

2 Choose Get Info from the File menu.

When multiple icons are selected, an Info window opens for each one.

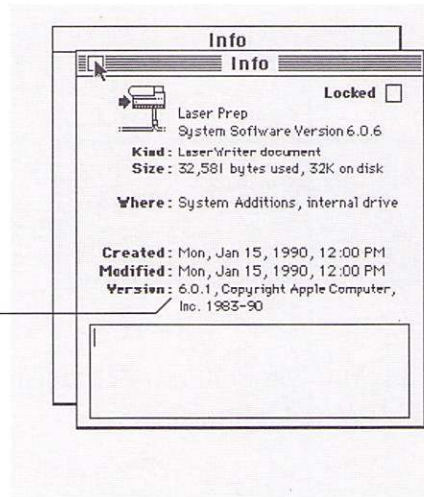

3 Check the version number of each LaserWriter driver.

Verify that the version numbers are 6.0 or later for the two LaserWriter files. Close the Info window for each file after you check its number.

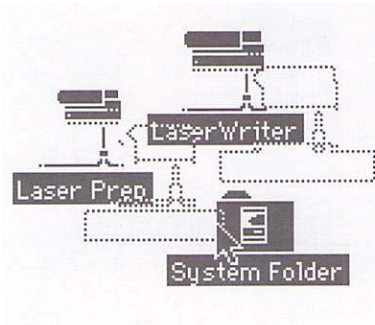

4 If necessary, drag the correct versions of the LaserWriter drivers to the System Folder of your startup disk.

If your System Folder already contains LaserWriter drivers, a message will appear asking you to confirm that you want to replace the drivers in the folder.

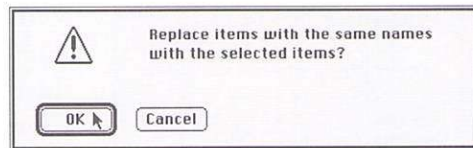

5 Click OK to confirm that you want the new drivers placed in the System Folder.

Printing color or gray-scale documents

You print color or gray-scale documents in much the same way as black-and-white ones.

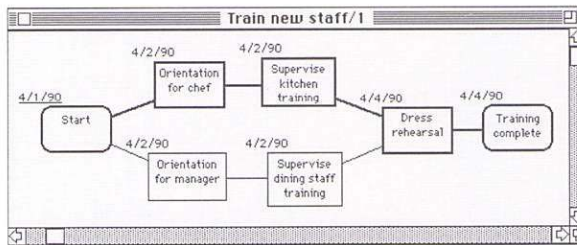

1 Prepare the color or gray-scale document you want to print and display it in the active window.

Alternatively, you can print from the desktop by selecting the icon of the document or documents you want to print.

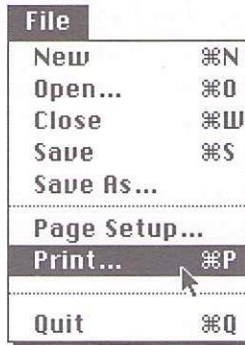

2 Choose Print from the File menu.

The Print dialog box appears, showing options for color/gray-scale and black and white. Color/gray-scale is the preset selection.

Color option is available only in the 6.0 LaserWriter driver (or a later version).

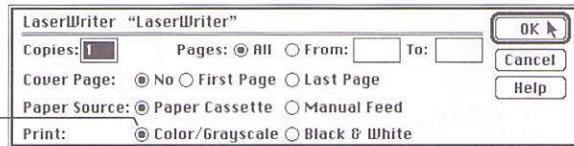

3 Select the options you want, then click OK.

If you are not printing a color or gray-scale document, it's a good idea to select the black-and-white option in the Print dialog box, because printing is faster when this option is selected.

If you print a color document on a printer that prints only in black and white, the document will be produced in a *halftone* format; that is, it will be composed of patterns of dots that vary in intensity according to the colors they represent in the document.

➤ *See also:* • "Installing 32-Bit QuickDraw for Enhanced Color Images" in Chapter 2

Printing while using the computer for other work

By using MultiFinder, you can print on a LaserWriter while continuing to work with one or more programs. This feature, known as *background printing*, doesn't work with the ImageWriter.

- See also:
- “Managing Multiple Programs Using MultiFinder” in Chapter 3
 - “Using a Print Server” in Chapter 7

Using background printing

With MultiFinder in effect, you use the Chooser to turn on background printing.

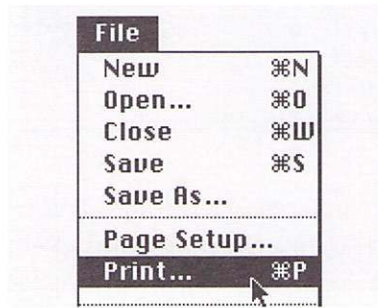

1 To use background printing, select the Chooser from the Apple menu.

The Chooser window opens.

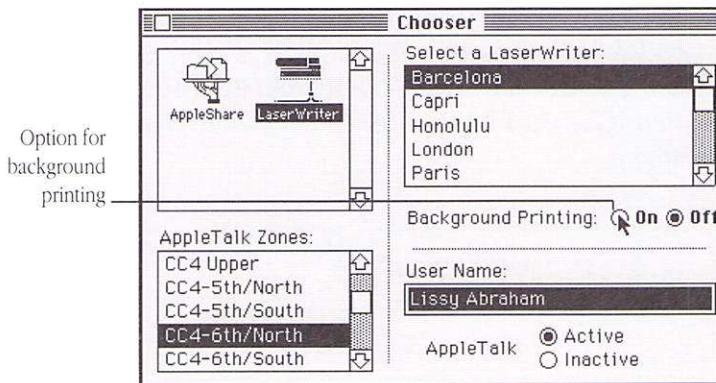

2 Make sure that a LaserWriter is selected, then click the On button in the middle area of the window to turn on background printing.

A LaserWriter must be selected in the Chooser for the Background Printing option to be displayed.

It's a good idea to close the Chooser before you activate the window containing the document you want to print.

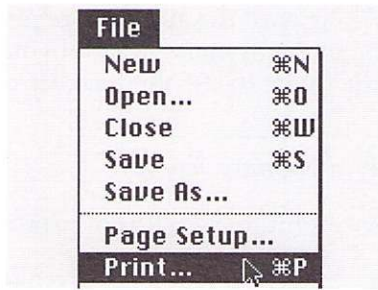

3 Print a document as usual.

Select the icons of documents you want to print on the desktop, or display a document in the active window of a program, and then choose the Print command from the File menu.

The Print dialog box appears; select the options you want and click OK.

Background printing is under way as soon as the printing status box disappears. You may notice an occasional pause as you continue your work while the Macintosh processes the document for printing.

Managing printing jobs

You can control background printing with PrintMonitor, a resource supplied with the system software. (See Figure 4-7.)



Figure 4-7 PrintMonitor window

Along with the appropriate printer driver, PrintMonitor must be in the System Folder of your startup disk. (You can drag it to the folder or use the Installer to copy it in your System Folder.)

PrintMonitor lets you

- monitor the status of printing
- cancel a document currently printing or waiting to print
- set printing time (date, hour) or postpone a job indefinitely
- monitor paper supply (PrintMonitor's icon blinks over the Apple symbol at the left of the menu bar when the printer is out of paper)
- signal when to feed paper manually (PrintMonitor's icon blinks over the Apple symbol to signal that you must confirm the manual operation)



PrintMonitor

1 To manage print jobs, make sure that **PrintMonitor is in the System Folder of your startup disk and that background printing is turned on in the Chooser.**

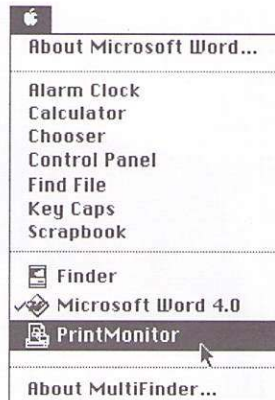

2 After you have started printing a document, choose PrintMonitor from the Apple menu.

The PrintMonitor window opens. (PrintMonitor is available only when background printing is under way.)

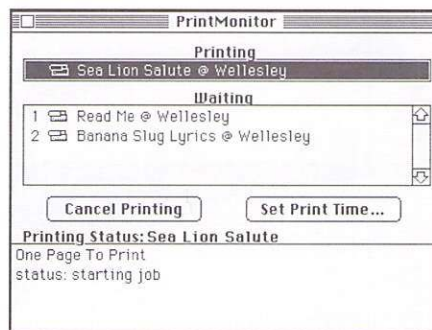

3 Select the option you want, then click the close box.

You can cancel printing of the current document or select one of the documents waiting to print. (The Cancel button changes to Remove from List when a waiting document is selected.) You can set a time and date for printing a selected document by clicking the Set Print Time button and entering the time and date in the dialog box that appears.

❖ *PrintMonitor shortcut:* You can also open the PrintMonitor window by clicking the MultiFinder icon in the top-right corner of the menu bar until the PrintMonitor's icon appears. ❖

➤ *See also:*

- “Managing Multiple Programs Using MultiFinder” in Chapter 3
- “Using a Print Server” in Chapter 7

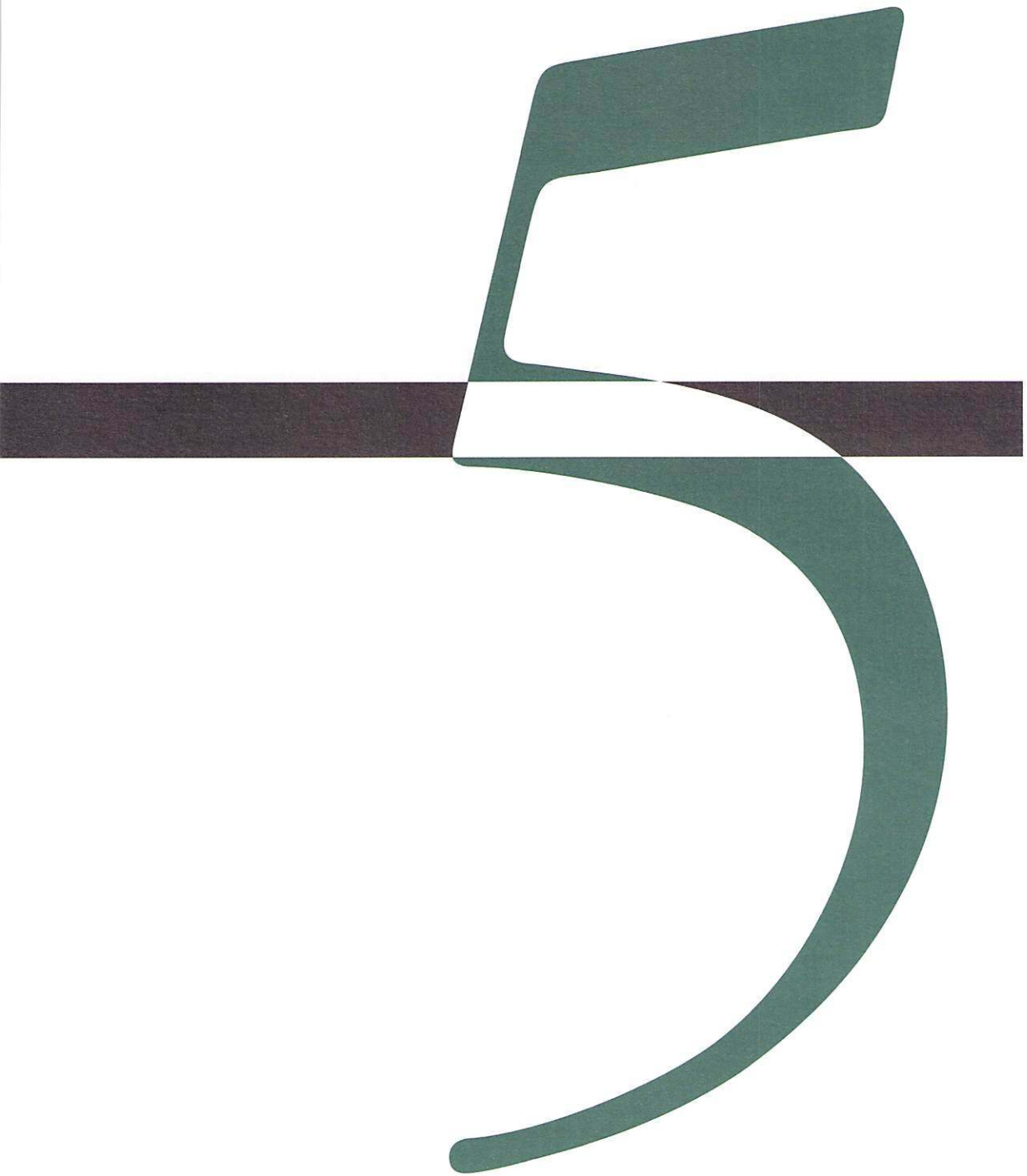

Organizing Documents

The Macintosh desktop simulates an office filing system—with icons representing documents, folders, and even a Trash container. Other icons represent application programs, disks, and other types of files.

The computer's electronic environment permits rapid handling of information, and Macintosh system software provides a number of tools for storing and locating documents easily and efficiently.

These include

- simple, versatile methods for naming and renaming documents and folders
- a “visual” filing system that's easy to move through by opening containers such as folders or disk icons
- a powerful desk accessory, Find File, to locate items by name or partial name
- directories of disk or folder contents arranged by icon, name, date, size, or type of document.
- easy display of important information about a document

Handling documents

You use standard Macintosh operations to name and rename documents, copy them, and move their icons. In addition, you can make one or more duplicates of any document without changing its name or location.

All these operations take place on the desktop.

Moving a document You drag a document to move it.



1 To move a document, first point to its icon.

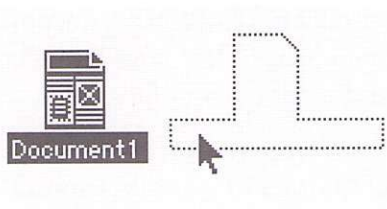

2 Drag the document's icon to the new location.

As you drag, an outline of the icon moves with the pointer. When you release the mouse button, the icon appears at the new location.

Copying a document
onto another disk

You drag the document's icon to the icon of a disk to copy it
onto that disk.

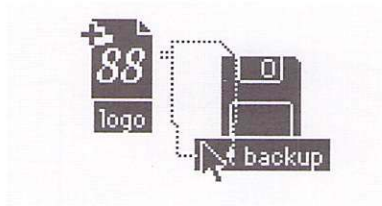
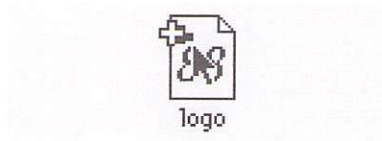

1 To copy a document
onto another disk, first
point to its icon.

2 Drag the document's
icon to the icon of the
disk onto which you want to
copy it.

As you drag, an outline of the
document's icon moves with
the pointer.

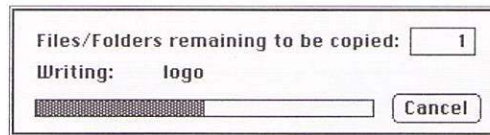

3 Release the mouse
button when the disk
icon becomes highlighted.

When you release the button,
the document is copied on the
disk. A dialog box reports the
status of copying.

Copying a document on the same disk

You can make a copy of a document on the same disk by using the Duplicate command.



1 To make a copy of a document on the same disk, first select the document.

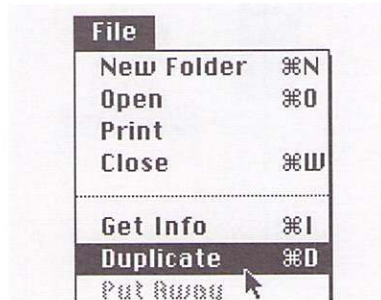

2 Choose Duplicate from the File menu.

The document is duplicated; it has the original's name, preceded by "Copy of." A dialog box reports copying status.

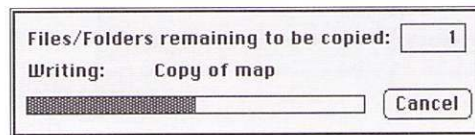

3 If necessary, rename the document or move it to another location on the disk.

You can't give the duplicate exactly the same name as the original if you keep both of them on the desktop or in the same folder.

- ❖ *Duplicating shortcut:* You can also use the keyboard shortcut Command-D to duplicate a selected document. ❖

Retaining a document

You use the standard desktop editing techniques to change a document's name.



1 To rename a document, first select it.



2 Type the new name for the document.

When you begin typing, the old name disappears and an insertion point blinks to the right of the characters you type.



3 Click anywhere outside the document's icon.

The insertion point disappears when you click, and the icon is deselected.

Using folders to organize your work

Like traditional filing systems, the Macintosh uses folders to store and organize documents. Unlike a bulky paper filing system, however, you can easily place folders inside one another to create up to 12 levels of files on the Macintosh.

Figure 5-1 shows an example of a floppy disk that contains three levels of folders.

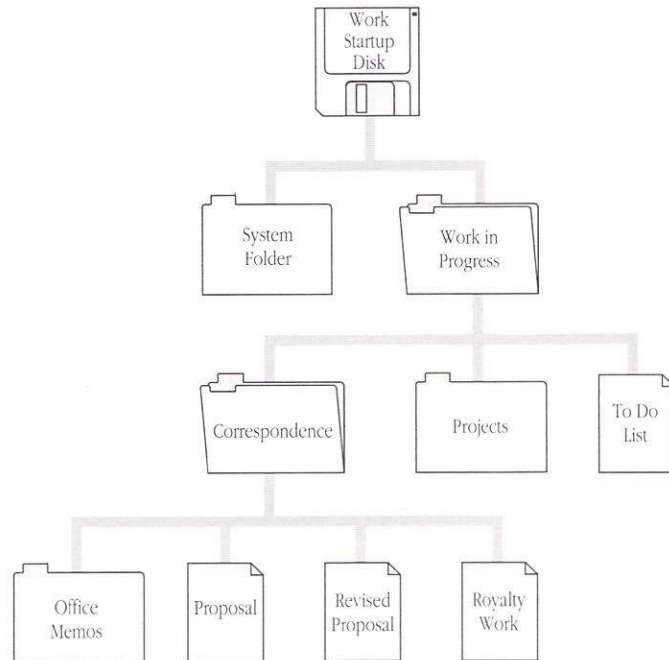
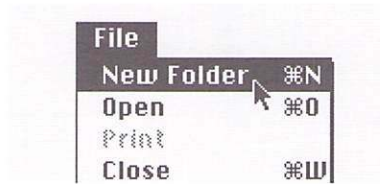

Figure 5-1 Three levels of folders and documents on a floppy disk

Whether you use a hard disk, which can store hundreds of folders and documents, or floppy disks for your files, you can establish an efficient filing system with folders.

Creating and naming folders

You use the New Folder command to create a new folder.



1 Choose New Folder from the File menu.

A new folder named “Empty Folder” appears in the active window; it is already selected, so you can easily rename it.



2 Type a name for the folder.

When you begin typing, the old name disappears, and an insertion point blinks to the right of the characters you type.



3 Click anywhere outside the folder's icon.

The insertion point disappears when you click, and the icon is deselected.

- ❖ *New folder shortcut:* You can also use the keyboard shortcut Command-N to create a new folder on the desktop. ❖

Placing documents inside folders

You drag documents to place them in folders.



1 To place a document inside a folder, first point to the document's icon.

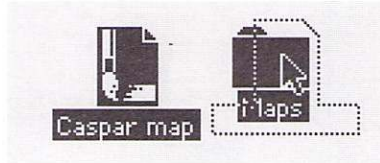

2 Drag the icon to the folder.

An outline of the document's icon moves with the pointer as you drag.



3 Release the mouse button when the folder's icon becomes highlighted.

The document disappears inside the folder when you release the mouse button. You can verify this action by opening the folder and viewing its contents.

Nesting folders

You can store folders inside other folders to create as many as 12 levels of storage. You nest folders by dragging them.



1 To place a folder inside another folder, point to the first folder's icon.

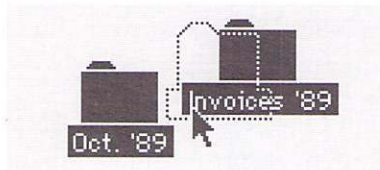

2 Drag the first folder's icon to the folder in which you want to nest it.

An outline of the first folder's icon moves with the pointer as you drag.



3 Release the mouse button when the destination folder's icon becomes highlighted.

The first folder disappears inside the destination folder when you release the mouse button. You can check this action by opening the folder and viewing its contents.

Locating documents and folders

Macintosh system software provides a desk accessory called Find File for locating documents and folders anywhere on a disk. When you're working with documents in a program, some dialog boxes provide menus that show levels of folders.

➤ See also: • "Installing a Desk Accessory" in Chapter 8

Finding documents by name or partial name

You can use the desk accessory Find File to locate a document or folder anywhere on a disk. It is installed as part of the standard system software for all Macintosh models with an internal hard disk drive.

Find File lets you specify the word or phrase for which it will search, reporting all documents and folders whose names contain the search text. Then, when you select a document from those listed, Find File shows that document's location. (See Figure 5-2.)

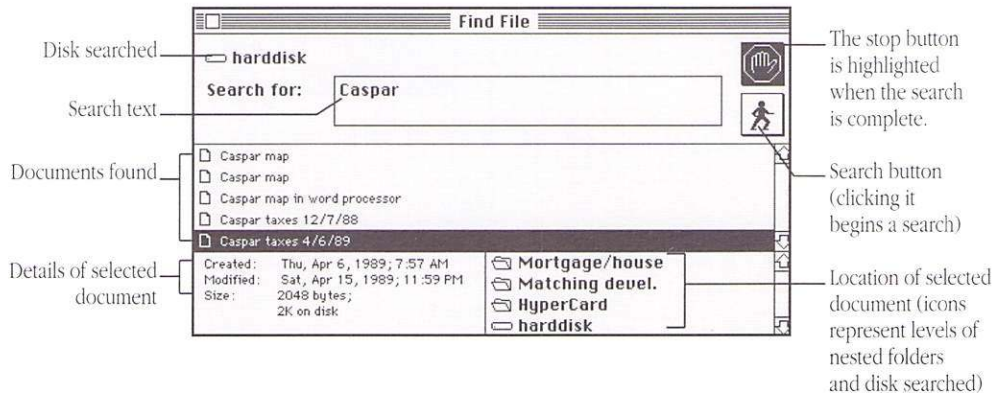
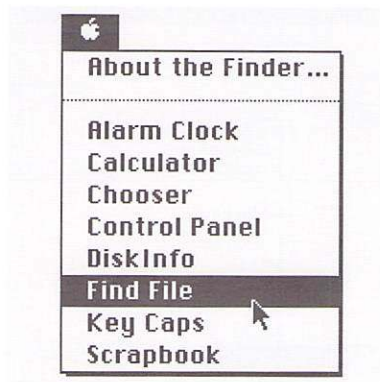
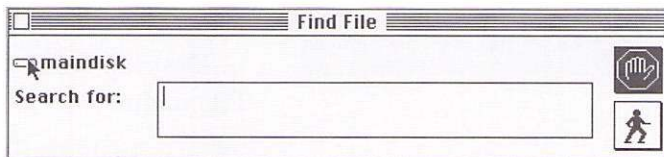

Figure 5-2 Find File showing search report and location of selected document



1 To search for a file, first choose Find File from the Apple menu.

The Find File window opens. A blinking insertion point is in the text box.



2 If necessary, click the disk icon at the upper-left corner of the window to switch disks for searching.

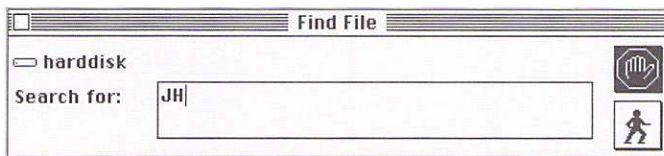

3 Type the text you want to locate.

The text can be the complete name or a partial name.

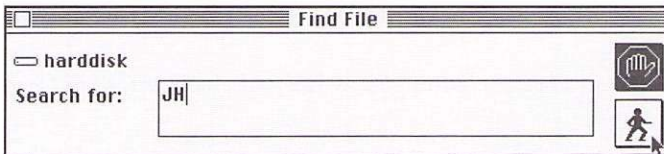

4 Click the search button (the icon of a walking figure).

Find File searches for the text, and then displays the names of documents and folders that contain the text.

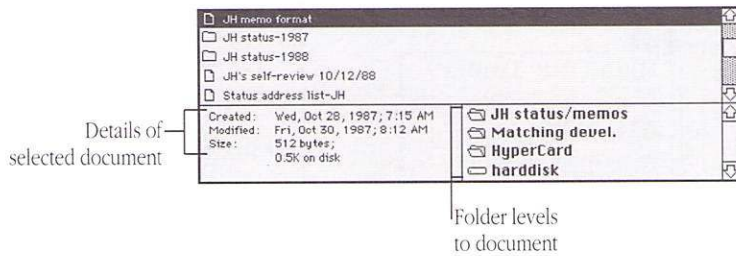

5 Select the document you want to locate (scrolling if necessary).

Information about the document and its location are displayed in the bottom panes of the Find File window.

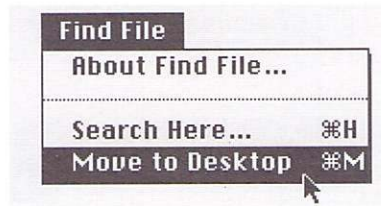

6 (Optional) To move the selected document or folder to the desktop immediately, choose Move to Desktop from the Find File menu.

The Find File menu, which appears to the right of other menu titles in the menu bar, is available only when the Find File window is open.

❖ *Another searching feature:* Find File also allows you to limit a search to a folder's contents with its Search Here command. This command is also available in the Find File menu. ❖

➤ *See also:* • "Putting Away Items on the Desktop" in Chapter 5

Moving quickly through levels of folders when using a program

When you're working in a program and want to open or save a document, you have a quick way to move around in multiple levels of folders on a disk: a *directory dialog box* that lets you change levels of nesting and even switch drives and eject disks. (See Figure 5-3.)

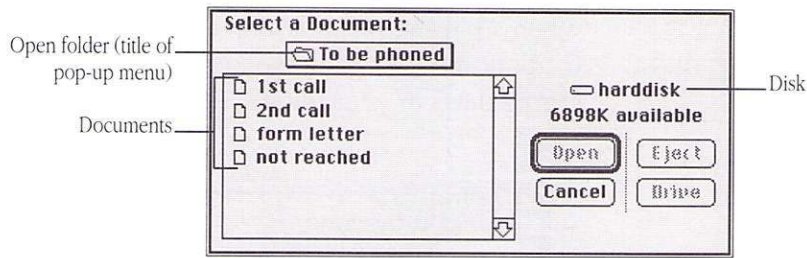

Figure 5-3 A directory dialog box showing a folder's contents

If the document used most recently is in a folder, the folder's name in the dialog box is actually the title of a menu that “pops up” when you place the pointer on it and press the mouse button.

The folder “To be phoned” in Figure 5-3 and Figure 5-4 is nested inside other levels of folders. Figure 5-4 shows those levels of folders; “To be phoned” is inside “'89 overdue,” which is inside “Oct. unpaid,” and so on. The last level in the pop-up menu is the disk.

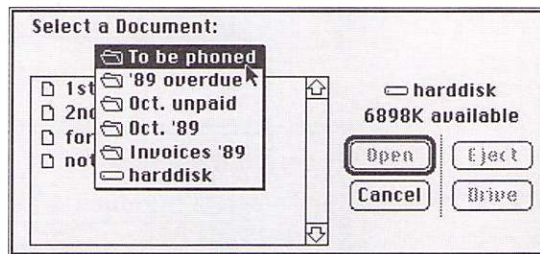
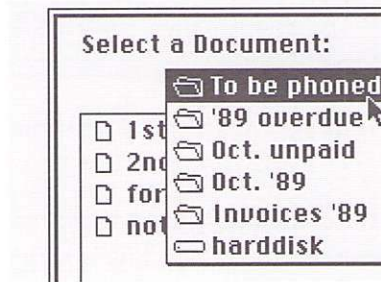

Figure 5-4 Open pop-up menu showing levels of folders and disk

Moving to a new folder level with a pop-up menu

When a pop-up menu is available in the directory dialog box of an application program, you can use it to move rapidly to another level of your filing system.



1 To move to a new level, first open the pop-up menu by pointing to its title and holding down the mouse button.

The pop-up menu opens, showing the levels of folders and the disk name.

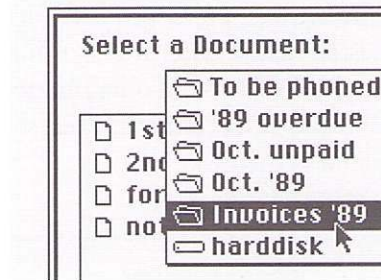

2 Drag the pointer to the name of the folder or disk to which you want to move.

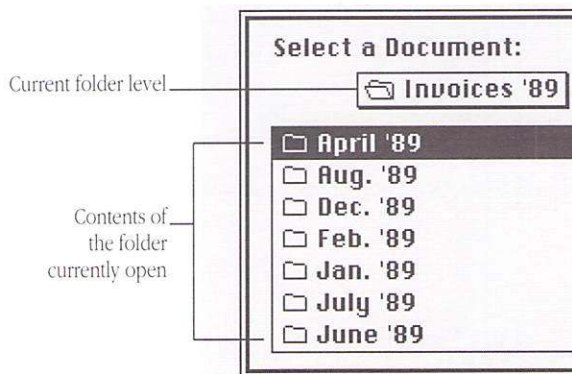

3 Release the mouse button to move to the new level.

When you release the button, the folder or disk name you chose appears as the title of the pop-up menu in the dialog box.

Putting away items on the desktop

Often the simplest way to use a program, document, or folder is to drag its icon out of a window onto the desktop. Then the icon stays on the desktop until you remove the disk on which the program, document, or folder actually is stored.

If you've placed an icon on the desktop, you can replace it in its original location quickly and easily with the Put Away command.



1 To put an item away, first select its icon.

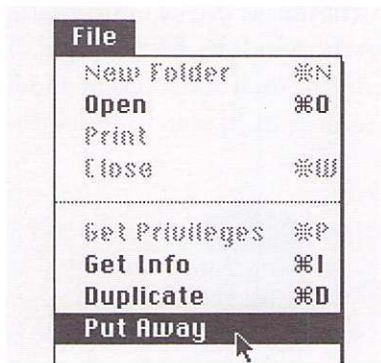

2 Choose Put Away from the File menu.

The selected item disappears from the desktop and is put back at the level where it originated. (You can check that the item has been put away by looking in its original location.)

Getting directory information

The Macintosh provides quick access to details about the documents and disks it manages.

The View menu, which is always available from the desktop, offers several different ways to view the contents of a disk or folder. Two other commands—Get Info and About—present details about individual documents and applications.

Displaying documents by name, size, date, kind, or color of icon

Using the View menu, you can list the contents of a window according to name, size, date, kind, or color of icon, in addition to by icon or small icon.

An icon view is useful when you want to move and select icons frequently. A directory arranged by name, size, date, kind of document, or color of icon is useful when one of those attributes is the key information you need about the documents in the window. For example, listing documents by the date and time of their most recent modification makes backing up a large number of files an orderly task.

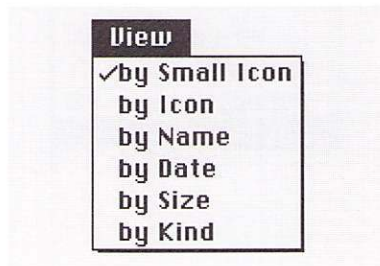

1 To change the way you view a window's contents, first open the View menu by pointing to its title and holding down the mouse button.

The View menu opens, showing the choices available. A check mark indicates the view currently visible in the active window.

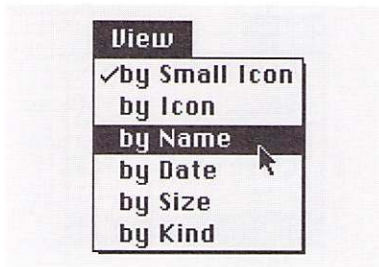

2 Drag until the view you want becomes highlighted.

Name	Size	Kind	Last Modified
April '89	--	folder	Wed, Nov
Aug. '89	--	folder	Wed, Nov
Dec. '89	--	folder	Wed, Nov
Feb. '89	--	folder	Wed, Nov
Jan. '89	--	folder	Wed, Nov
July '89	--	folder	Wed, Nov

3 Release the mouse button to change to the new view.

When you release the button, the view in the active window changes to the item you chose from the View menu.

Getting information about an icon

The Get Info command displays information about a single item on the desktop or in an open window.



1 To get information, first select the icon for which you want details.

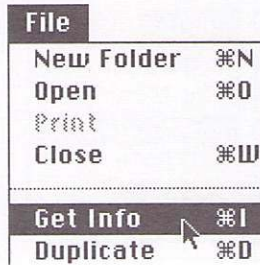

2 Choose Get Info from the File menu.

The Info window appears, displaying information about the selected icon.

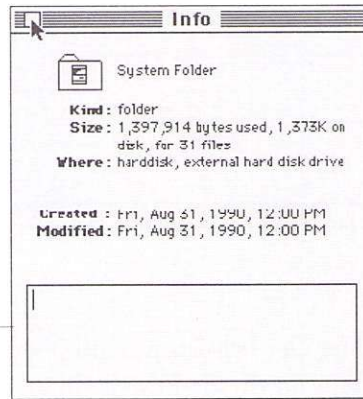

3 Click the close box to close the Info window when you're finished.

Text box for adding notes

- ❖ *Get Info shortcut:* You can use the keyboard shortcut Command-I to display information about the selected item. ❖
- ❖ *Another use for the Info window:* You can also use the Info window to lock the contents of a document. ❖
- *See also:* • “Protecting Information on a Disk” in Chapter 6

Getting information about a program

You use the About command in the Apple menu to get information about the program currently in use. From the desktop, the About command provides details about the Finder.

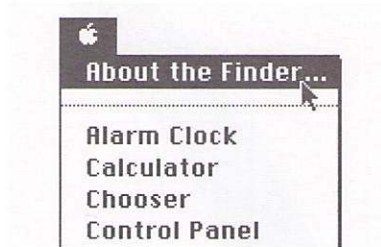

1 To get information about a program, choose About from the Apple menu. (The program's name is part of the command.)

The About window appears, displaying details about the program.

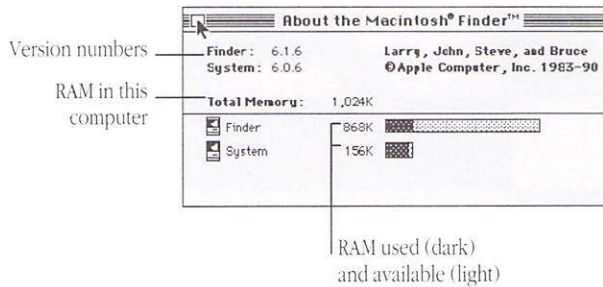

2 Click the close box to close the About window when you're finished.



Managing Disks and Disk Drives

Disks are the Macintosh's principal storage medium. Every Macintosh model has at least one internal *floppy disk drive*, and many models offer an internal *hard disk* as well.

The system software and most applications are supplied on 3.5-inch floppy disks, which are ideal for transporting data and backing up important work.

Hard disks offer the advantages of large storage capacity and speed of operation, although they are not as easily transported as floppy disks.

Using floppy disks

The floppy disks used in a Macintosh are flexible plastic disks (the source of the name “floppy”) inside a hard plastic case 3.5 inches wide. A metal shutter at one end of the disk slides to one side when the disk is in the drive, exposing the flexible plastic on which information is stored. The plastic is coated with a magnetic layer similar to that of recording tape (such as in tape cassettes).

Disk capacities

The amount of information a floppy disk can store depends on the type of disk drive in which it is used and on the way the disk is *initialized*—that is, the way its magnetic surface is electronically prepared to store data.

Macintosh disks have one of three capacities:

- 400 kilobytes (K)
- 800K
- 1.4 megabytes (MB)

Consult the *Special Options and Technical Information* booklet that came with your computer for the capacity of floppy disks used in your Macintosh model.

High-density disks and SuperDrive

Disks with a capacity of 1.4 MB are *high-density* disks and are used in the Apple SuperDrive™ high-density disk drive. High-density disks usually have the letters “HD” on their case or metal shutter. High-density disks also have an extra hole in their plastic case (on the opposite side from the disk-locking tab), which allows the SuperDrive to recognize them.

△ **Important:** Use high-density disks in the SuperDrive only. You cannot use these disks in drives that accept only 800K or 400K disks. (See Figure 6-1.) △

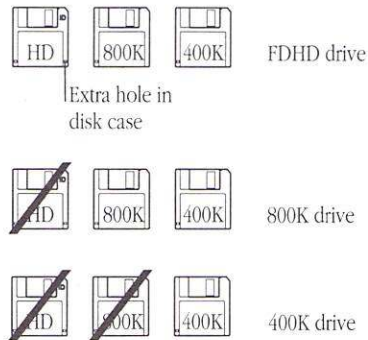
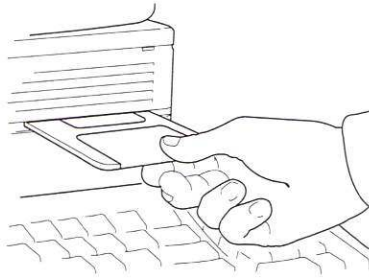

Figure 6-1 Proper use of floppy disks

The SuperDrive accepts all three types of floppy disks—400K, 800K, and 1.4 MB. This drive can also read 3.5-inch disks from computers that use the MS-DOS operating system.

- *See also:*
- “Locking a Floppy Disk” in this chapter
 - Appendix C, “Exchanging Disks and Files With MS-DOS Computers”

Inserting a disk



1 Slide the disk, metal end first and label side up, into the drive.

The disk snaps into place.

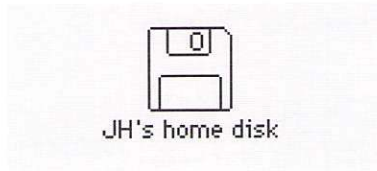

2 Check the screen to be sure that the disk has been recognized.

The screen will show either an icon for the disk or a dialog box reporting that the disk is unreadable.

- *See also:*
- “Initializing and Naming a Disk” in this chapter
 - “Testing and Repairing a Disk” in Chapter 10

Ejecting a disk from the desktop

You can easily eject a floppy disk from the desktop.



1 Point to the icon of the disk you want to eject.

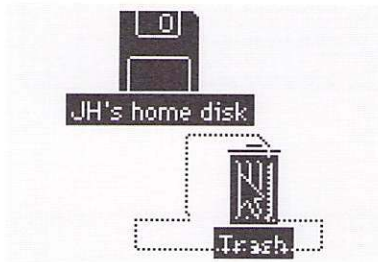

2 Drag the disk icon to the Trash icon.

When the Trash icon becomes highlighted, release the mouse button. The disk is then ejected.

- ❖ *Other ways to eject a disk:* You can also select a floppy disk and choose Eject from the File menu, or use either of two keyboard shortcuts to eject a floppy disk. Command-E ejects the selected floppy disk; Command-Shift-1 ejects the disk in the internal drive (the first drive if there are two); Command-Shift-2 ejects the disk in the second internal drive or an external floppy disk drive. ❖

- *See also:*
 - “Initializing and Naming a Disk” in this chapter
 - “Testing and Repairing a Disk” in Chapter 10

Ejecting a disk from within a program

You can eject a disk when you're working in a program by using a command, such as Open or Save As, that displays a directory dialog box.

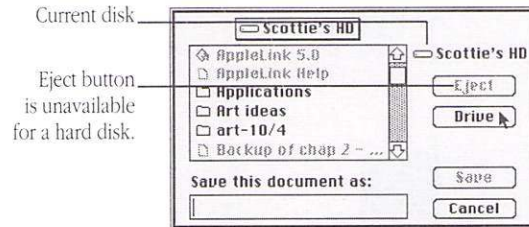

1 With the directory dialog box displayed in a program, click the Drive button to locate the disk you want to eject.

Skip this step if the displayed disk is the one you want.

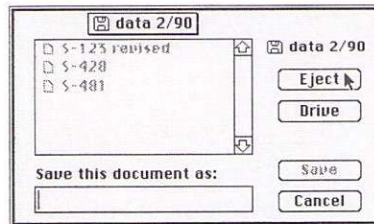

2 Click the Eject button to eject the current disk.

The disk is ejected. You can then insert a different floppy disk. (The Eject button is dimmed, and thus doesn't operate, when a hard disk is selected.)

Initializing and naming a disk

You name a disk when you initialize it. *Initializing* (also called *formatting*) prepares a new disk to store information; if a disk already contains data, initializing it erases that data.

- ▲ **Warning:** Be sure that any disk you plan to initialize contains no information you want to save, because you'll lose that information during initialization. ▲

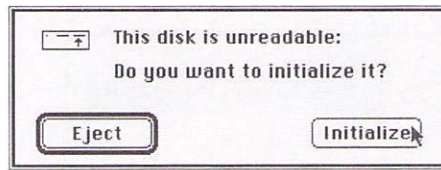

High-density disk

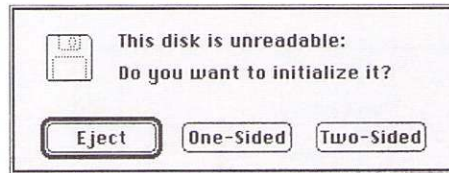

800K disk

1 After placing a new disk in the disk drive, click Initialize (if the disk is a high-density one), Two-Sided (for an 800K disk), or One-Sided (for a 400K disk).

A second dialog box appears, advising you that initializing will erase the disk. (If the disk has already been initialized and is not damaged, neither dialog box will appear—you'll just see the disk icon.)

You can click Eject if you don't want to initialize the disk.

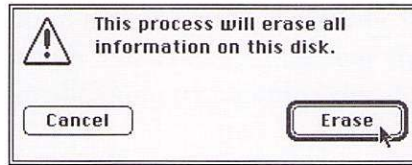

2 Click the Erase button to continue initialization.

You can click Cancel to avoid erasing the disk.

If you click Erase, a third dialog box appears, asking you to name the disk.

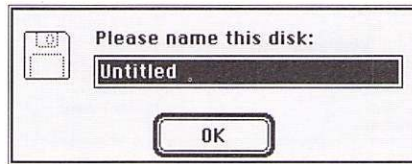

3 Type the name you want for the disk.

If you don't name the disk, it will have the name "Untitled" when it is initialized.

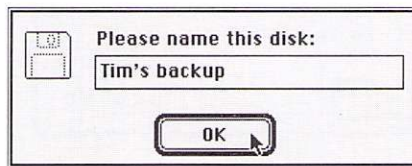

4 Click OK to complete the initialization process.

Initialization proceeds, with a status box reporting its progress. When the process is complete, the disk icon appears on the desktop, with the name you typed.

➤ *See also:* • Appendix C, "Exchanging Disks and Files With MS-DOS Computers"

Erasing a disk Initializing a disk erases any information on it. To erase an already initialized disk, use the Erase Disk command in the Special menu; this command actually reinitializes the disk.

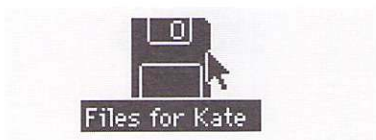

1 To erase a disk, first select the icon of the disk you want to erase.



2 Choose Erase Disk from the Special menu.

An alert box appears, giving you a chance to cancel the erasure and asking you to select the capacity of the disk after it is erased.

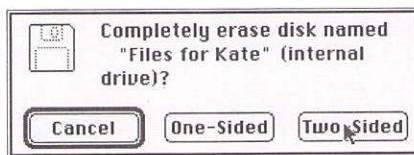

3 Click the button for the disk capacity you want.

The disk is erased and initialized for the selected capacity (one-sided is 400K, two-sided is 800K). A status box on the screen reports the progress of this procedure. (If you're initializing a high-density disk, the buttons are named Cancel and Initialize. Click Initialize.)

Renaming a disk You can easily rename a disk.



1 To rename a floppy disk, first select its icon.



2 Type a new name for the disk.

When you begin typing, the pointer disappears. The insertion point blinks at the end of the text you type.

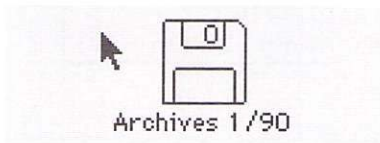

3 Click anywhere outside the disk icon.

When you click, the insertion point disappears and the icon is deselected.

Backing up a disk

Although floppy disks are designed to last through thousands of hours of use, they can become damaged or worn. So it's wise to make backup copies of important work and application programs, especially if you use only floppy disks with your Macintosh.

You can make backup copies of individual documents as necessary, but you probably will want to back up such essential disks as startup disks, system software master disks, and program master disks.



1 To make a backup copy, first point to the icon of the floppy disk you want to back up (the source disk).

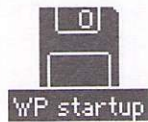

2 Drag the icon of the floppy disk you want to back up to the icon of the disk on which the copy will be made (the destination disk).



The destination disk can be either a floppy disk (as pictured) or a hard disk. If the destination disk is a floppy disk, an alert box appears, asking you to confirm that the information being copied will replace the contents of the destination disk.

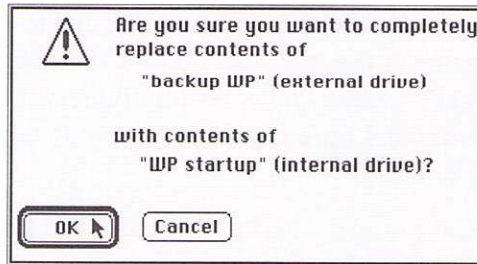

3 Read the message to make sure you're making the correct decision, then click OK to begin the backup procedure.

Your disk is backed up; a dialog box reports the progress of copying.

(If you click Cancel rather than OK, no backup takes place.)

- ❖ *One floppy disk drive:* If your Macintosh has only one floppy disk drive (and no hard disk), you can use this backup procedure, but you'll have to swap disks a number of times. ❖
- *See also:* • "Backing Up a Hard Disk" in this chapter

Using a hard disk

A *hard disk* consists of metal disks permanently sealed inside a drive compartment. The drive's sealed environment permits extremely fast reading and writing of information, and the multiple disks inside a drive store 20 to 160 megabytes, or even more.

Hard disk precautions

Because the components inside a hard disk drive are very close together and moving very fast when the drive is turned on, these drives should be handled with care.

Observe these precautions when working with a hard disk:

- Avoid jostling or rough handling of the drive (and thus of the Macintosh with an internal hard disk). Never move a Macintosh when the hard disk drive is operating.
- Some models of the Macintosh are designed to operate either sitting flat or turned on one side. *Setting Up Your Macintosh* for your model includes special instructions if your model can be placed on one side. Do not place the computer on its side unless it is designed to operate this way; it could affect hard disk operation.
- Always keep the drive on a sturdy, level surface.
- Operate a hard disk at temperatures between 50 and 104 degrees Fahrenheit and at a relative humidity of 20 to 80 percent.
- Avoid spilling any liquids on or near the drive.
- Do not expose the drive to hazardous vapors, such as those from cleaning solvents.

Initializing and naming a hard disk for the first time

You use the Apple HD SC Setup program, supplied on one of the system software disks, to initialize and name a hard disk for the first time. *Initializing* (also called *formatting*) prepares the disk's surface to store information.

The internal hard disks in many Macintosh models are initialized at the factory; these drives do not have to be initialized again before you use the computer. If the disk in your computer has been initialized, you'll see the disk's icon on the desktop when you first turn on the computer.

- ▲ **Warning:** If you received a hard disk with A/UX on it, *do not* initialize that disk; doing so will erase A/UX. Instead, see the A/UX documentation for instructions. ▲



- 1 To initialize a hard disk, start Apple HD SC Setup by double-clicking its icon.

The program's main dialog box appears.

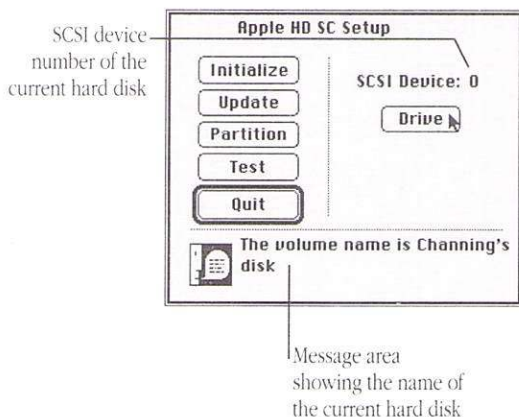

- 2 If necessary, click the Drive button to select the disk you want to initialize.

The current disk's SCSI device number is displayed above the Drive button; the disk's name is shown in the message area at the bottom of the dialog box.

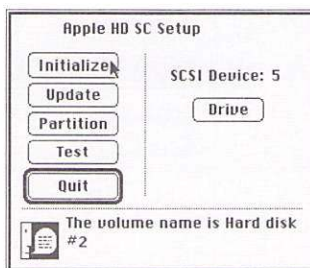

3 When the number and name of the hard disk you want are displayed, click **Initialize** to begin initializing.

A dialog box appears in which you must confirm or cancel your decision to initialize.

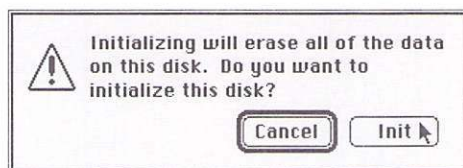

4 Click **Init** to initialize the hard disk.

When you click, the pointer becomes a spinning beach ball and the message area of the dialog box reports the status of initialization. After a short while, the computer's alert sound signals the end of the process, and a message reports successful initialization. (If you see a report that initialization has failed, begin the process again.)

A dialog box appears, asking you to name the disk.

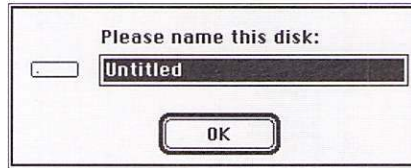

5 If necessary, type a name for the hard disk, then click OK.

If the disk has been initialized previously, the naming dialog box will not appear.



6 Click Quit when the message reports successful initialization.

- See also:
- “Setting the SCSI Device Number” in Chapter 9
 - “Testing and Repairing a Disk” in Chapter 10

Partitioning a hard disk

You *partition* a hard disk—that is, divide its storage area into two or more separate sections—so that the disk can be used by different types of computers, such as the Macintosh and the Apple IIgs™, or by different operating systems, such as the standard Macintosh system and A/UX.

Δ **Important:** Apple recommends that, whenever possible, a separate hard disk be used for each different operating system. This strategy is preferable to partitioning a single hard disk for use by two operating systems. Δ

The instructions that follow provide a summary of the partitioning process; be sure to consult the documentation for the other operating system or systems you will use on the partitioned hard disk for details regarding your choice of partitioning options.

- ▲ **Warning:** If you received a hard disk with A/UX on it, *do not* partition that disk; doing so will erase A/UX. Instead, see the A/UX documentation for instructions on partitioning. ▲



- 1 To partition a hard disk, start Apple HD SC Setup by double-clicking its icon.

The program's main dialog box appears.

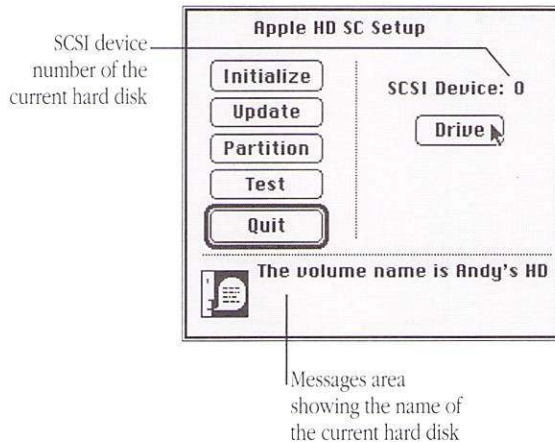

- 2 If necessary, click the Drive button to select the disk you want to partition.

The current disk's SCSI device number is displayed above the Drive button; the disk's name is shown in the message area at the bottom of the dialog box.

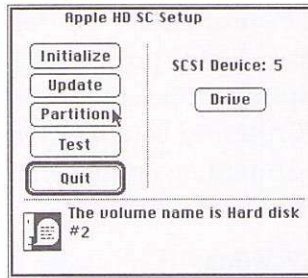

3 When the number and name of the hard disk you want are displayed, click Partition to begin the partitioning process.

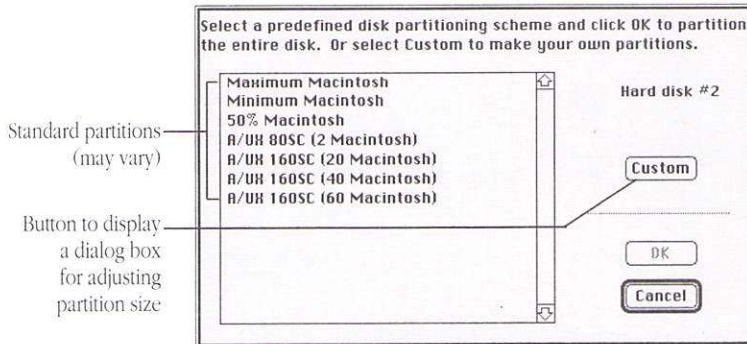

4 Select a standard partition from the list, or click Custom to adjust partition size, then click OK to partition the hard disk.

Consult the documentation for the other operating system you plan to use for specific partitioning instructions. The standard partitions available may vary; the list shown here is representative.

When you click OK, a dialog box appears giving you a chance to confirm or cancel your decision to partition.

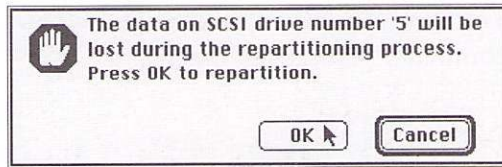

5 Click OK to partition the hard disk.

When you click OK, the pointer becomes a wristwatch and the message area of the dialog box reports the status of partitioning. After a short while, the computer's alert sound signals the end of the process, and a message reports successful partitioning. (If you see a report that partitioning has failed, begin the process again.)

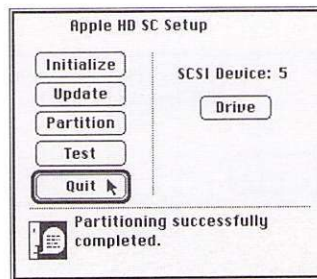

6 Click Quit when the message reports successful partitioning.

➤ *See also:* • "Setting the SCSI Device Number" in Chapter 9

Erasing a hard disk

You can erase a hard disk using the Erase Disk command. This command reinitializes the disk.



1 To erase a hard disk, first select the icon of the disk you want to erase.



2 Choose Erase Disk from the Special menu.

An alert box appears, asking you to confirm that you want to initialize the disk and giving you a chance to cancel the erasure.

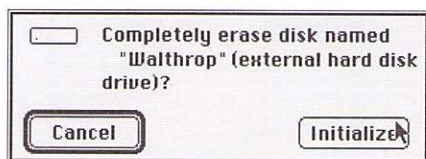

3 Click the Initialize button.

The disk is erased and reinitialized. A status box on the screen reports the progress of this procedure.

(Clicking Cancel rather than Initialize cancels the erasure.)

Renaming a hard disk You rename a hard disk with the standard editing steps.



1 To rename a hard disk, first select its icon.

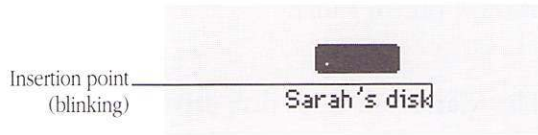

2 Type a new name for the disk.

When you begin typing, the pointer disappears. The insertion point blinks at the end of the text you type.

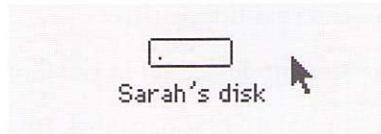

3 Click anywhere outside the disk icon.

When you click, the insertion point disappears and the icon is deselected.

Backing up a hard disk You can back up the work you store on a hard disk by copying individual files in the usual way (dragging their icons to the icon of another disk).

You can also use a commercial backup program to copy some or all files from a hard disk to another hard disk, to a tape drive, or to a series of floppy disks.

Whatever method you use, be sure to back up important files and programs on your hard disk regularly.

- *See also:*
- “Backing Up a Disk” in this chapter
 - “Backing Up the Session’s Work” in Chapter 3

Startup disk sequence

The Macintosh follows a set procedure, called the *scanning order*, to locate a startup disk. The computer always looks first in the floppy disk drives, then it looks at external and internal hard disks.

You can specify which device will be the first hard disk in the computer's scanning order by using the Startup Device section of the Control Panel.

The scanning order for a startup disk

The Macintosh scans disk drives for a startup disk in the following order:

- internal floppy disk drive
- second internal floppy drive
- external floppy drive
- startup device set in the Control Panel
- internal SCSI hard disk (the computer waits 15 seconds for the internal drive to warm up)
- external SCSI hard disk (if more than one, in descending order of device numbers)
- internal hard disk (the computer returns to this drive and waits another 15 seconds)
- floppy disk drive (if no startup disk has been recognized, the computer displays a blinking question mark over a floppy disk icon and waits for a startup disk to be inserted in a floppy drive)

➤ *See also:*

- “Specifying Items to Be Opened at Startup” in Chapter 2
- “Setting the SCSI Device Number” in Chapter 9

Designating a hard disk as the startup device

If you use more than one hard disk with your Macintosh, you should specify which one is the startup disk. You use the Startup Device section of the Control Panel for this task. (See Figure 6-2.)

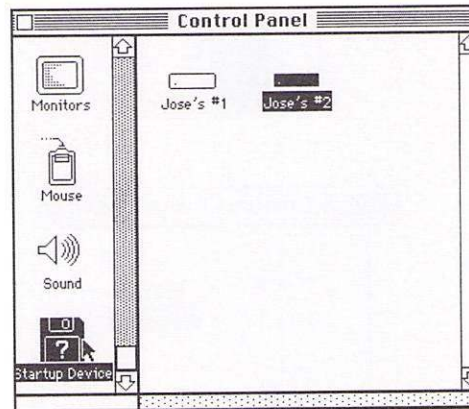
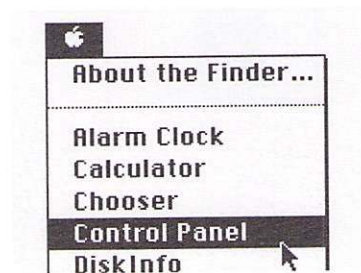

Figure 6-2 The Startup Device section of the Control Panel

When you designate a startup device, it precedes all other devices except floppy disks in the scanning order.



1 To set a startup device, first choose the Control Panel desk accessory from the Apple menu.

The General Control Panel appears.

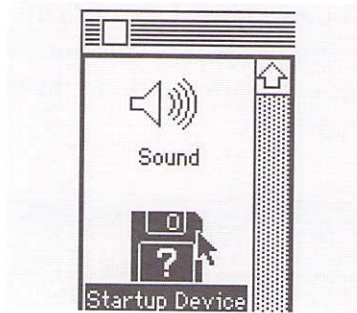

2 Scroll if necessary, then select the Startup Device icon in the left area of the Control Panel.

The Startup Device section appears.

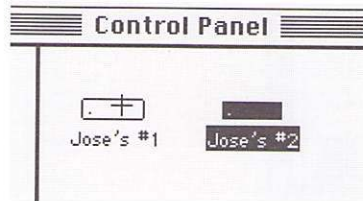

3 Click the icon of the disk you want to be the startup device.

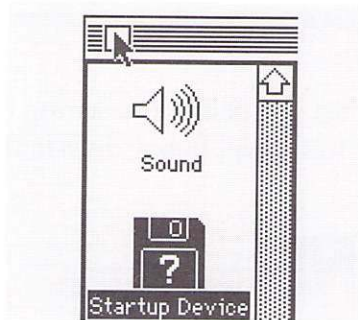

4 Click the close box to close the Control Panel.

It's a good idea to close the Control Panel, although you can leave its window open.



5 Choose Restart from the Special menu.

The computer restarts, using the disk you specified as the startup device.

➤ *See also:* • “The Scanning Order for a Startup Disk” in this chapter

Protecting information on a disk

You can protect all the information on a disk by locking the disk itself, or you can lock individual documents and applications in the Info window.

The information in a locked document or disk can't be changed or thrown away; it can usually be opened or copied, however.

Locking a floppy disk

You adjust a tab on the disk's plastic case to lock it.

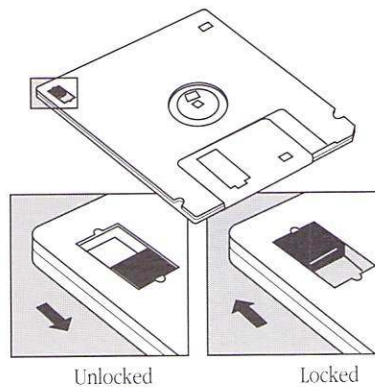

1 To lock a floppy disk, first locate the tab at the top-left corner on the back of the disk.

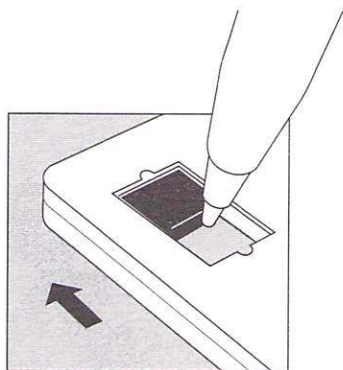

2 Slide the tab upward with the tip of a ballpoint pen (or a similar tool).

The disk is locked when the tab is in the upper position and an opening is visible in the disk's case below the tab.

Sliding the tab down (covering the opening in the case) unlocks a floppy disk.

Locking documents You use the Get Info command to lock a document.

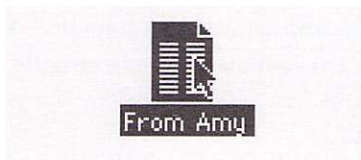

1 To lock a file, first select its icon.

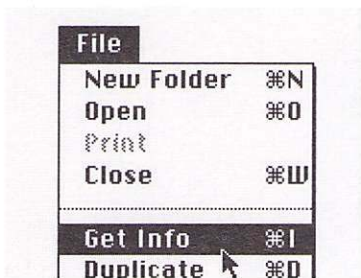

2 Choose Get Info from the File menu.

The Info window opens.

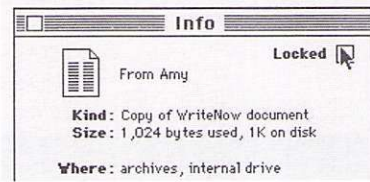

3 Click the Locked box in the upper-right corner.

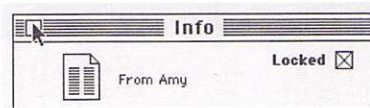

4 Click the close box to close the Info window.

The document is now locked.

You can also lock a program using the Info window (to prevent the program's being erased, for example), but locking a program may affect its operation.

- ❖ *Locking folders:* You can't use Get Info to lock folders; however, you can protect the contents of folders on an AppleShare file server by using the Access Privileges desk accessory in the Apple menu. ❖

➤ *See also:* • "Creating Private Files on a File Server" in Chapter 7

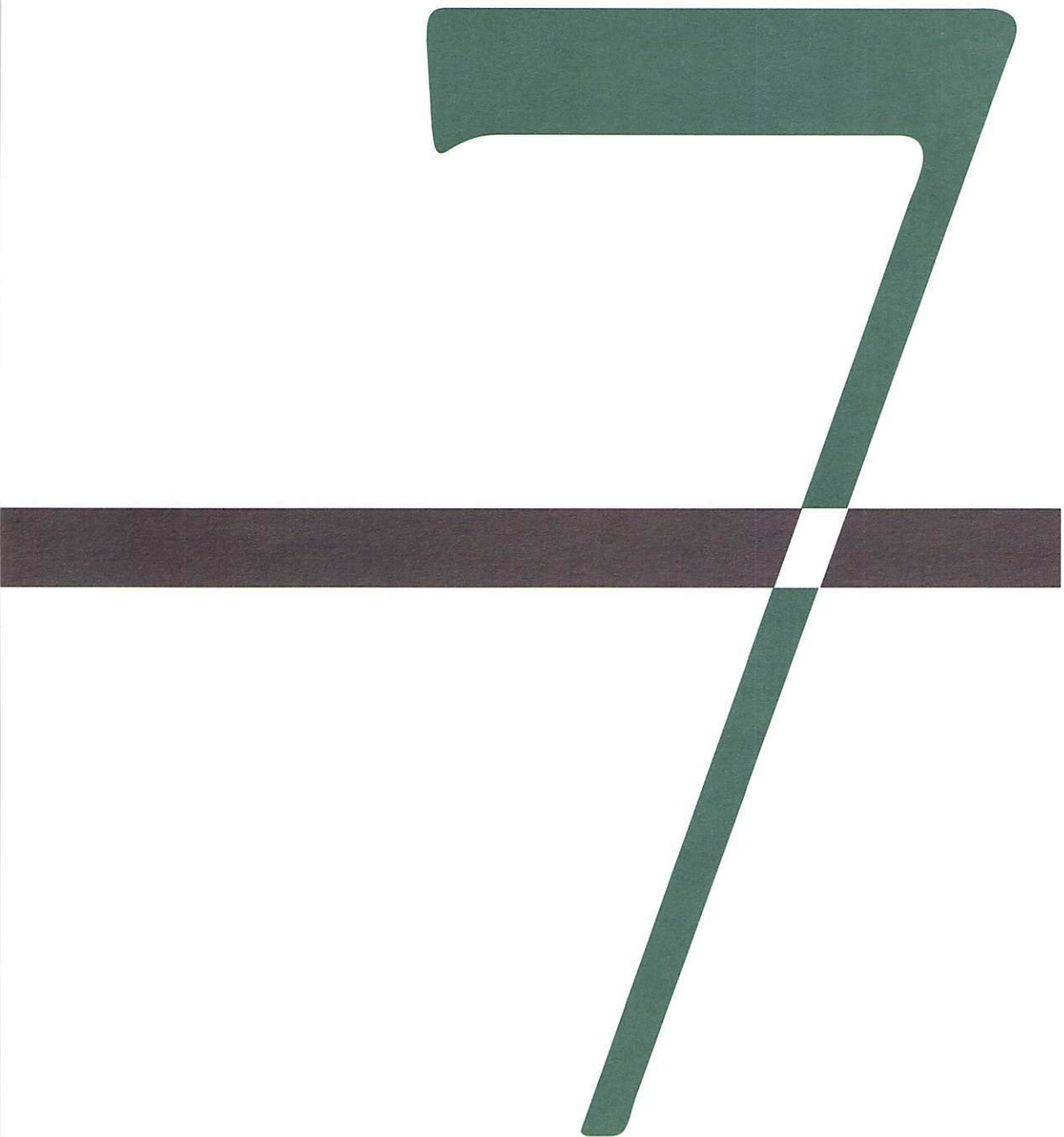

Using the Macintosh on a Computer Network

All Macintosh models have built-in circuitry for connecting to a LocalTalk™ network. LocalTalk is one of the network types available in the AppleTalk™ network system—a means to connect computers, printers, and other devices so that their users can share information and resources. Some Macintosh models can use expansion cards that provide connections for other types of AppleTalk networks in addition to LocalTalk.

This chapter provides an introduction to using the Macintosh as part of a network and instructions for using the parts of the system software that are designed for network operations.

Adding the Macintosh to a network

You can easily connect the Macintosh to a network that uses the computer's built-in LocalTalk circuitry. If your Macintosh model has slots for expansion cards, you can install a card to provide a connection to a different type of network, such as Ethernet.

Connecting to an existing LocalTalk network

You can add your Macintosh to an existing LocalTalk network, or you can connect one or more LocalTalk devices to the Macintosh and create your own small network.

The instructions that follow provide a summary of procedures for connecting to an existing network. Consult the documentation provided with the LocalTalk connector and cable for a more detailed treatment of this task.

To make the LocalTalk connection, you use a built-in connector on the Macintosh—the printer port—and a LocalTalk cable (or a compatible cable).

Δ Important: If you are adding the Macintosh to an existing network, notify the other computer users on that network, and arrange to make your connection at a time that won't disrupt the network's operation. Δ

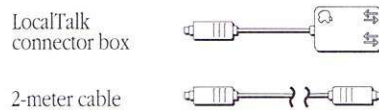

1 To connect to an existing LocalTalk network, first assemble the components you need: LocalTalk connector box and cable, extender and extra cable if necessary, and the Macintosh.

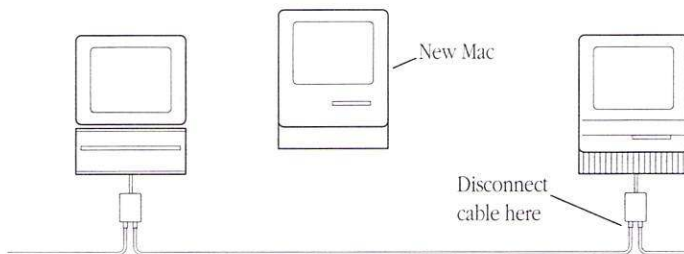

2 Unplug the LocalTalk cable from the LocalTalk connector box of the device that will be next to your Macintosh on the network.

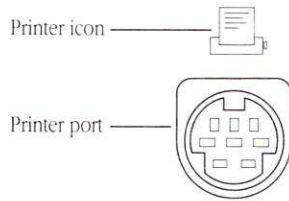

3 Plug the cable end of the LocalTalk connector box into the Printer port on the back panel of the Macintosh.

You can recognize the Printer port by the icon above it on the case.

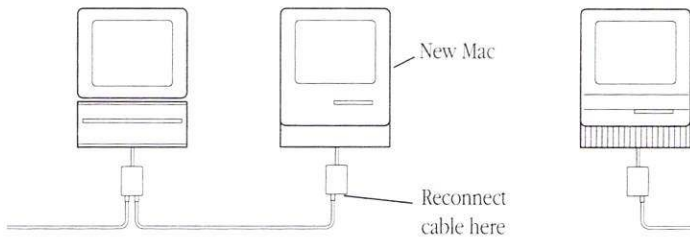

4 Plug the cable you unplugged earlier into one of the sockets in the the LocalTalk connector box now attached to your computer.

If the cable isn't long enough, you can attach a cable extender and additional cable to it.

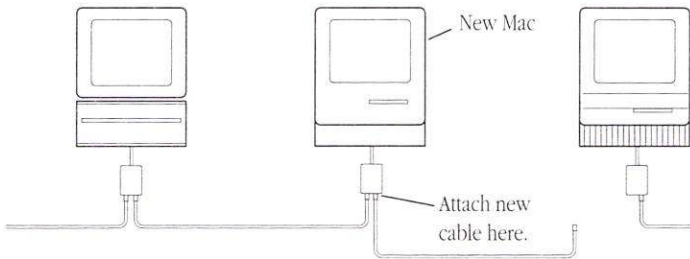

5 Plug one end of your LocalTalk cable into the second socket in the LocalTalk connector box attached to your Macintosh.

If the cables aren't long enough, you can attach a cable extender and additional cable to one or both of them.

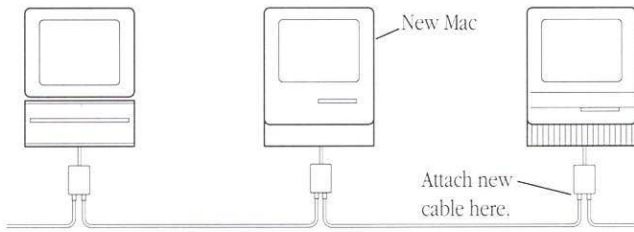

6 Plug the other end of your LocalTalk cable into the empty socket of the LocalTalk connector box attached to the computer next to yours on the network (the one from which you originally detached a cable).

Now your Macintosh is part of the network.

When you've completed the network cable connections, it's a good idea to make sure that all cables and devices you worked with have been reconnected to a LocalTalk connector box. Two cables should be attached to the connector box for all devices on the network except for those at either end of the network. Devices at the end should have only one cable in their connector boxes. (See Figure 7-1.)

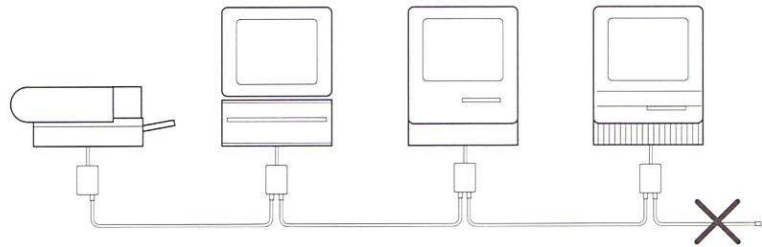

Figure 7-1 A LocalTalk network with one too many cables

As noted, some Macintosh models can also connect to other types of AppleTalk networks. Instructions for these connections are provided with their specialized hardware and software.

Preparing the Macintosh system software for networking

The system software supplied with the Macintosh contains elements for some network operations. Depending on what devices your Macintosh network uses, you may need to install some or all of these parts of the system software on your startup disk:

- LaserWriter printer drivers—LaserPrep and LaserWriter
- ImageWriter printer driver—AppleTalk ImageWriter
- ImageWriter LQ printer driver—LQ AppleTalk ImageWriter
- AppleShare driver (for using an AppleShare file server or print server)
- Access Privileges desk accessory (for checking your access to files on an AppleShare file server)
- any special software supplied with networking cards or other network devices, such as Ethernet software if you install an EtherTalk™ card.

You also need to be sure that AppleTalk is turned on if you want your Macintosh to use the services of an AppleTalk network system.

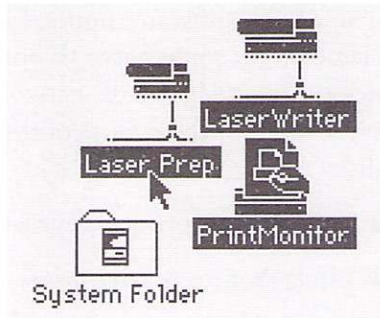

1 To prepare the Macintosh system software for network use, first place all the drivers for your network's AppleTalk devices in the System Folder of your startup disk.

You can copy these drivers by dragging them into the System Folder of your startup disk, or you can use the Installer to add them to your system. They include the printer drivers.

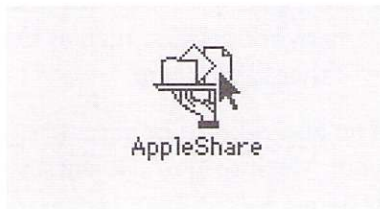

2 If necessary, install the AppleShare resource by following any special AppleShare instructions supplied with your Macintosh model or by dragging it to the System Folder of your startup disk.

If no special instructions for AppleShare installation are provided with your Macintosh and you plan to use an AppleShare file server, be sure to place the AppleShare resource in your System Folder by dragging its icon or by using the Installer program's Custom option.

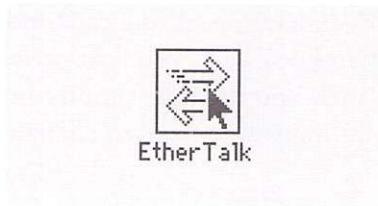

3 Copy or install any other necessary software for network devices on your startup disk.

Consult the documentation for that software for specific instructions.

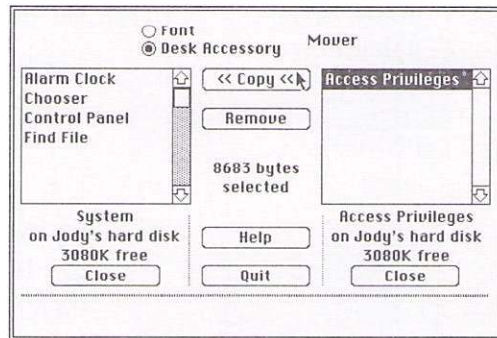

4 If you are using an AppleShare file server, use the Font/DA Mover to install the Access Privileges desk accessory.

Skip this step if you are not using an AppleShare file server.

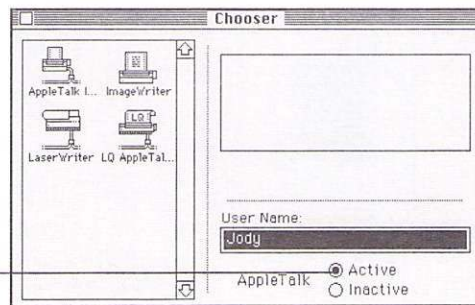

Active button selected indicates that AppleTalk is on.

5 Confirm that AppleTalk is turned on in the Chooser. If it's not, click the Active button to turn it on.

- See also:
- "Creating a Customized System" in Chapter 2
 - "Installing a Desk Accessory" in Chapter 8

Changing from one network to another network

If you have installed a card and software for a network other than LocalTalk, you have a Network section in the Control Panel. You use this section to designate which type of network you want to use and to change from one network to another.

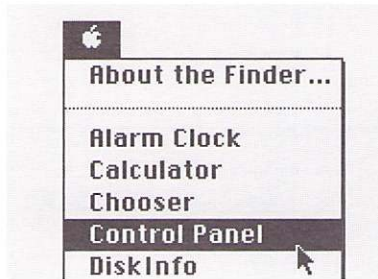

1 To change from one type of network to another, first choose Control Panel from the Apple menu.

The Control Panel opens, with the General section displayed.

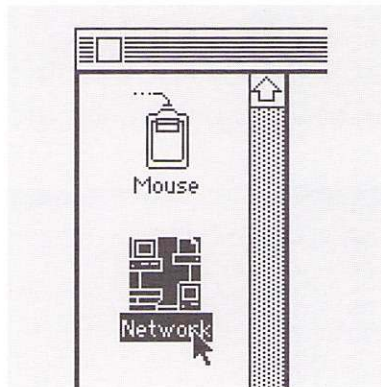

2 Scroll if necessary to locate the Network icon, then click it to display the Network section.

The Network Control Panel appears, with the icon of the network currently in use selected. The pointer becomes a crosshair when you place it in the area where the network icons are located.

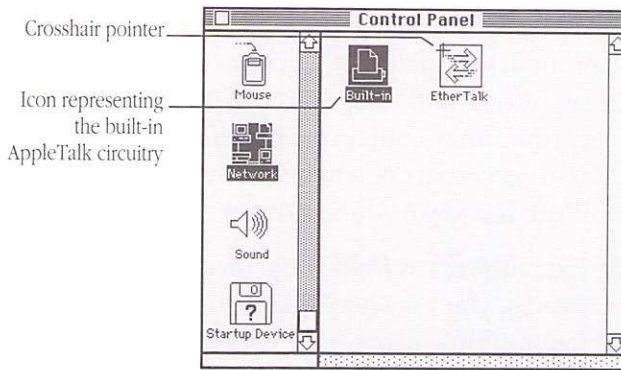

3 Click the icon for the network you want to select.

When you select the icon, it becomes highlighted. You may then see a message alerting you that you will lose your connection with the devices on your currently connected network.

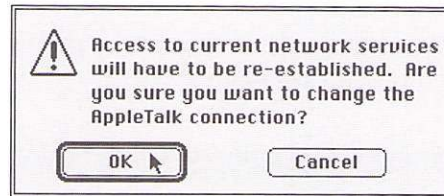

4 Click the OK button to confirm the change of networks.

If you aren't sure that you want to change networks, click Cancel and consult the network administrator or the documentation for the network products you're using.

After you close the Control Panel, your choice remains in effect until you choose a different network.

Using a printer on the network

Like the Macintosh, most models of the LaserWriter printer have built-in AppleTalk circuitry and connectors. The ImageWriter and ImageWriter LQ printers can also be used on a network if they contain an AppleTalk adapter. If your Macintosh is part of a network that has more than one printer, you can use any of those printers.

If your network is linked together with other AppleTalk networks, you may have access to printers on other networks. When multiple networks are interconnected, the resulting *internet* may be divided into AppleTalk *zones* for easier management. You can select any zone listed in the Chooser to use printers and servers available in that zone.

You specify the zone and the printer you want to use with the Chooser. (See Figure 7-2.)

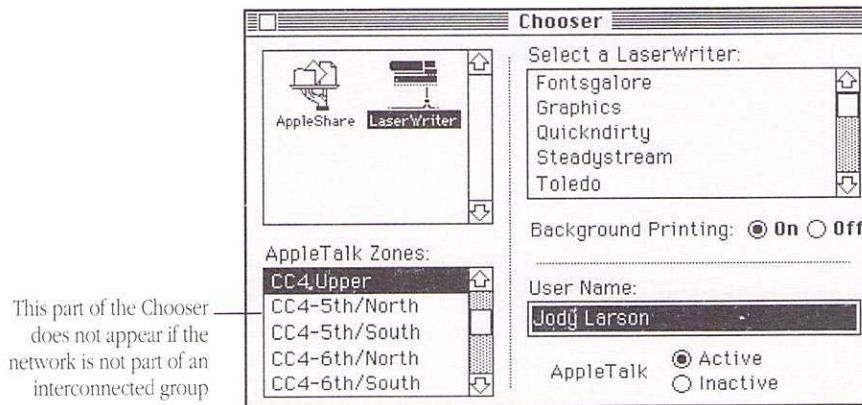
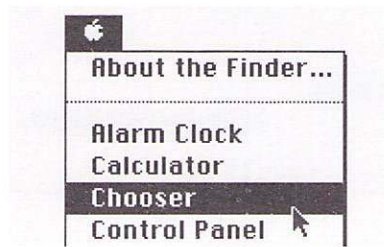

Figure 7-2 The Chooser showing zones and LaserWriter printers

Choosing a network printer

You use the Chooser to designate both network printers and any connected directly to your Macintosh.



1 To specify a network printer, first select the Chooser from the Apple menu.

The Chooser opens.

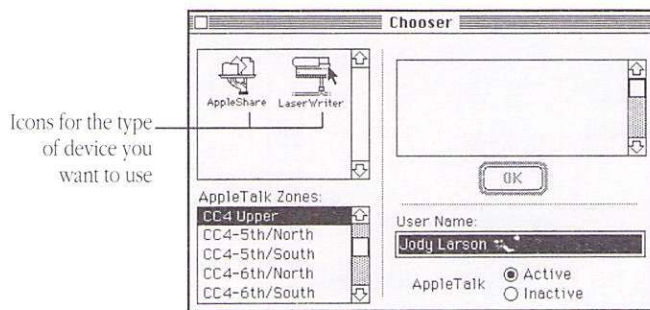

2 If necessary, locate the icon for the type of printer you want to use, then click the icon to select it.

You may have to scroll to locate the icon. When you select a different type of device, the list in the box on the upper right changes to the names of available devices.

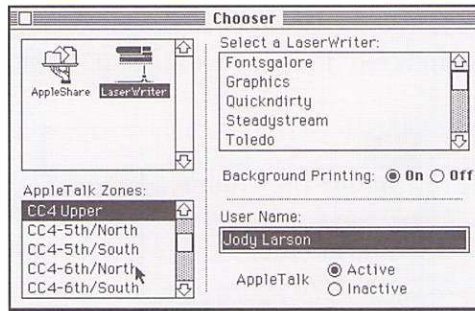

3 If necessary, locate the name of the zone in which you want to use a printer, then click that zone to select it.

You may have to scroll to locate the zone you want. When you select a different zone, the printer names change in the upper-right part of the window.

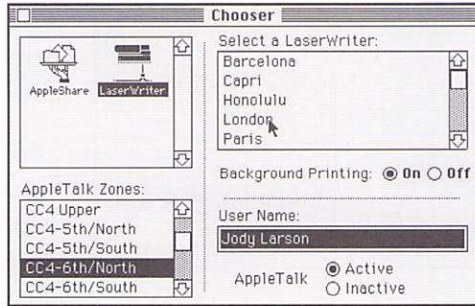

4 Click the name of the printer you want to use.

You may have to scroll to locate the name.

Your choice takes effect immediately and remains in effect until you choose a different printer. (It's a good idea to close the Chooser window.)

Printing your work on a network printer

Once you have designated the printer you want to use (with the Chooser), you simply print your documents in the usual way—by using the Print command in an application program or by selecting one or more documents on the desktop and choosing Print from the File menu.

➤ See also: • “Printing Your Work” in Chapter 4

Using a print server

A *print server* is a combination of hardware and software that manages printing jobs sent to it by a number of computers on a network. A print server is often called a *spooler*, a term that is generally used as part of its name on the network.

If your Macintosh is part of a network that contains a print server, you can send printing jobs to it and make the most efficient use of your computer for other work. You may wish to turn off background printing if you use a print server.

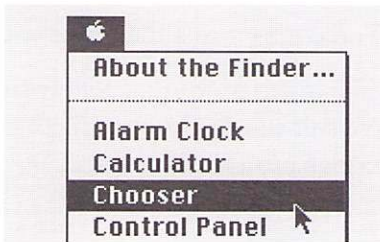

1 To use a print server, first open the Chooser desk accessory in the Apple menu.

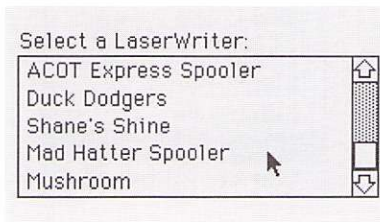

2 Follow the regular steps for choosing a printer, but select one that has Spooler in its name.

You may have to scroll to locate the name.

When you print a document, the printing status box appears for a few moments, then closes. You can now use your Macintosh for other work while printing.

► *See also:* • “Using Background Printing” in Chapter 4

Using an AppleShare file server

If your Macintosh is part of a network that has an AppleShare file server, you can expand your access to programs and data significantly without adding any components to your own computer. You can also create private files on the server and designate who will have access to them.

In addition, a file server allows you to exchange information with anyone else on your network or in a zone that you can reach from your computer.

Gaining access to an AppleShare file server

You connect to a file server with the Chooser.

The instructions that follow summarize the connection process; consult the AppleShare file server documentation for a complete explanation of all options.

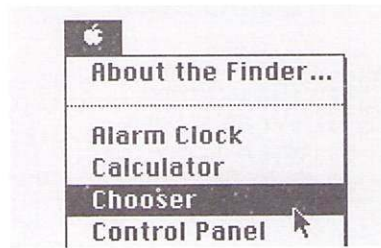

1 To gain access to an AppleShare file server, first select the Chooser from the Apple menu.

The Chooser opens.

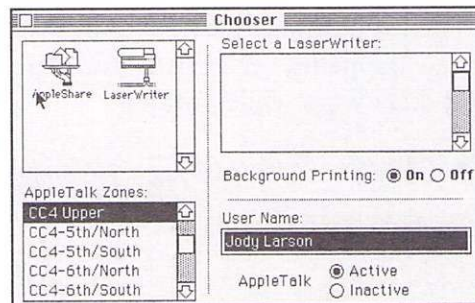

2 Click the AppleShare icon to select it.

When you select a type of device, the names of the devices available appear in the upper-right list box.

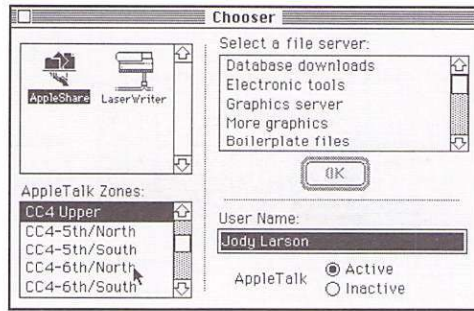

3 If necessary, click the name of the zone in which you want to use a file server.

You may have to scroll to locate the zone you want. When you select a different zone, the server names change in the list box at the upper-right side of the window.

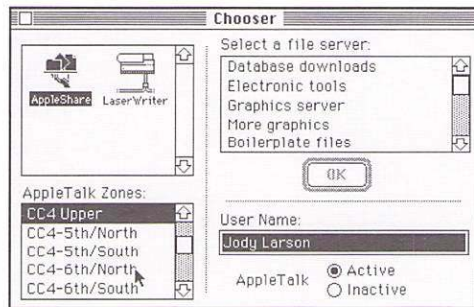

4 Click the name of the file server you want to use.

You may have to scroll to locate the name.

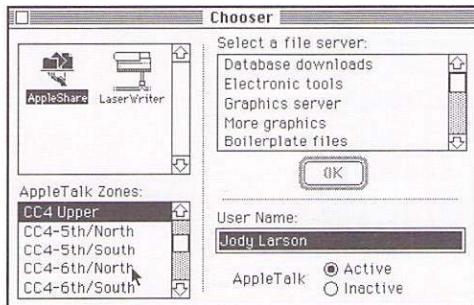

5 Click OK when the name of the file server you want to use is selected.

A dialog box appears when you click OK, in which you provide information for connecting to the server.

Guest does not require name or password (but may have limited access to information).

Registered user's name and password must match those in a master file on the server or access will be denied.

Connect to the file server "Budgets 91 & 92"
as:
 Guest
 Registered User
Name: Jody Larson
Password: ***** (Scrambled)
Cancel Set Password OK

6 To connect to the server as a Registered User, type or correct your name if necessary. (Your name must match the form with which you are registered.) Then, type your password. If you're not a registered user, click the Guest button, if it's not dimmed.

Your name will be inserted automatically if you've supplied a user name in the Chooser. When you type your password, you won't see the characters on the screen (for security), so type carefully.

If the Guest option is dimmed and you're not a registered user, you won't be able to connect to the server.

Connect to the file server "Budgets 91 & 92"
as:
 Guest
 Registered User
Name: Jody Larson
Password: ***** (Scrambled)
Cancel Set Password OK

7 Click OK.

When you click OK, another dialog box appears, in which you select the portions of the file server you want to use.

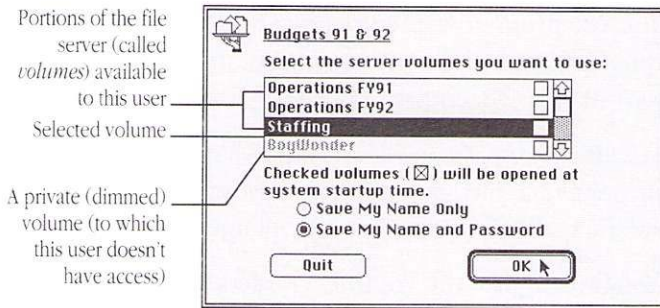

8 Select the name or names of the volumes you want to use, then click OK.

You may have to scroll to locate the volume or volumes you want. When you click OK, the dialog box closes and the selected volume or volumes appear as AppleShare icons on your desktop in the area where disk icons appear.



9 Use a file server volume as you would a disk, opening it and using the documents and folders in its window or creating new documents on it.

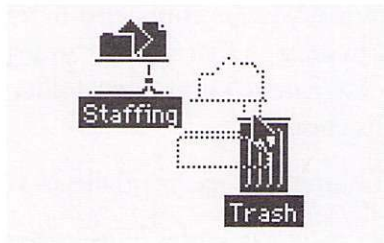

10 When you're finished using a file server volume, drag its icon to the Trash to disconnect your Macintosh from it.

Storing and retrieving information on an AppleShare file server

You use programs, documents, and folders on a file server in much the same way you use them on a disk in a drive that is part of your Macintosh system.

Because an AppleShare file server provides a means of limiting access to programs and files, however, you may not be able to use some server volumes and some folders on the volumes that are available to you.

You'll recognize the volumes, folders, and documents to which you do not have access because their icons (or their names in a list) are dimmed in the server window.

With the exception of dimmed items, you can copy items from the file server to your disks, create and edit documents on the server, use programs on the server, and copy or save items from your Macintosh to the server.

Consult the AppleShare file server documentation or see the network administrator for your work group for more detailed information about file server use.

Creating private files on a file server

When you are connected to a file server as a registered user, you can create and assign access privileges to folders. That is, you designate who can use a folder and what the users can do with its contents.

In brief, the access privileges you can assign include

- three categories of users—owner (you), group (any group registered on the server by the administrator), and everyone (all registered users and guests who have access to the server)
- three types of privileges for each of these user categories—the privilege to see any folders inside the folder you created; the privilege to read or copy any documents or programs in the folder (but not to change any); and the privilege to make changes to any of the folder's contents, including deleting items from it

Consult the AppleShare file server documentation or the network administrator for your work group for more detailed information about AppleShare's access privileges.

Connecting to another computer via modem

You can obtain a great deal of electronic information by using a *modem*—a device that converts computer signals for transmission over telephone lines—to communicate with other computers.

You can connect to numerous commercial information services and free bulletin boards by modem, and you can also connect directly with another individual computer user if that person's system is equipped with a compatible modem and controlling software.

You need a *communications program* to direct the modem's operations and a telephone line that is relatively free of static or other interference. The documentation for a modem and for communications programs can provide specific instructions for connecting with other computers via modem.

Once you've made a connection with another computer, you can use the communications program to send and receive files and to perform many activities on the other computer.

➤ *See also:* • “Connecting a Modem” in Chapter 9



Personalizing Your Macintosh Work Space

The Macintosh is designed to let you adjust some aspects of its operation and its screen's appearance. These customizable items include

- mouse operation
- keyboard operation
- sound and volume
- time and date
- the look of the desktop
- colors or shades of gray
- fonts and desk accessories

Most of these adjustments are made in the Control Panel. Some use desk accessories or other parts of the system software supplied with the Macintosh. A few adjustments, such as screen brightness and monitor position, are made with the hardware.

Adjusting mouse operation

You can modify two aspects of mouse operation—pointer movement and double-clicking speed—in the Mouse section of the Control Panel. (See Figure 8-1).

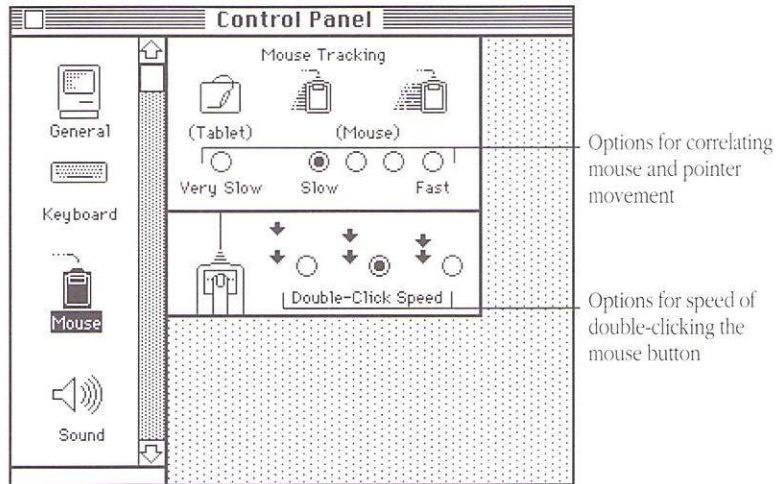

Figure 8-1 The Mouse Control Panel

Setting the correlation between mouse and pointer movement

The correlation between mouse and pointer movement, called mouse tracking, can be adjusted so that the pointer moves the same distance on the screen as the mouse moves, or so that the pointer moves up to two times as far on the screen as the mouse moves, depending on how fast you move the mouse.

Mouse tracking is preset to slow when you install the system software. The options for tracking are

- Slow—the mouse and the pointer move the same distance
- Fast—the pointer moves twice as far as the mouse

- Buttons between Slow and Fast—graduations between one-for-one and two-for-one pointer and mouse movement
- Very Slow/Tablet—the pointer moves at a constant speed when the mouse is moved, a useful setting for drawing with the mouse or using a graphics tablet

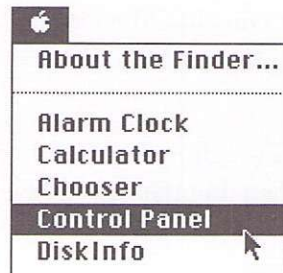

1 To set mouse tracking, first choose Control Panel from the Apple menu.

The Control Panel opens, with the General section displayed.

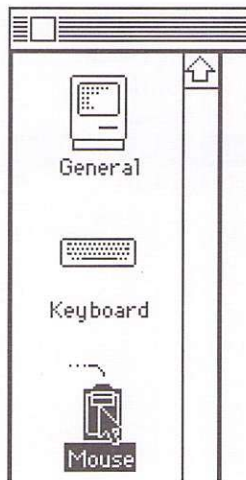

2 Scroll if necessary to locate the Mouse icon, then click it to display the Mouse section.

The Mouse Control Panel appears. The pointer becomes a crosshair when you place it in the Mouse Tracking area.

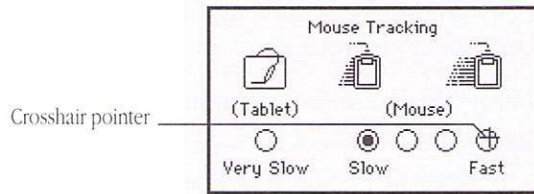

3 Click the button for the tracking option you want.

The new tracking option is in effect; you can test it by moving the mouse.

After you close the Control Panel, your choice remains in effect until you choose a different tracking option.

Setting the double-clicking speed

You can adjust the double-clicking speed of the mouse button by changing the interval between clicks.

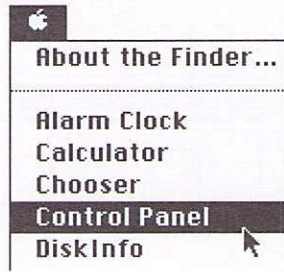

1 To set the double-clicking speed, first choose Control Panel from the Apple menu.

The Control Panel opens, with the General section displayed.

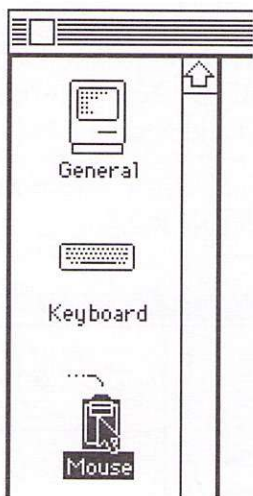

2 Scroll if necessary to locate the Mouse icon, then click it to display the Mouse section.

The Mouse Control Panel appears. The pointer becomes a crosshair when you place it in the double-click area.

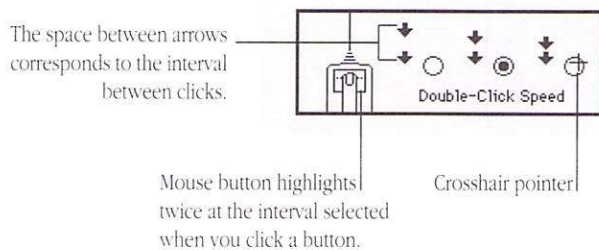

3 Click the double-clicking speed you want.

When you click, the mouse button on the screen is highlighted twice at the interval you selected.

Your choice remains in effect until you choose a different double-clicking speed.

Adjusting keyboard operation

You can adjust the rate of character repetition when a key is held down as well as the delay before the character begins repeating. These adjustments can be made with any Macintosh model and keyboard.

You make these adjustments in the Keyboard Control Panel. (See Figure 8-2.)

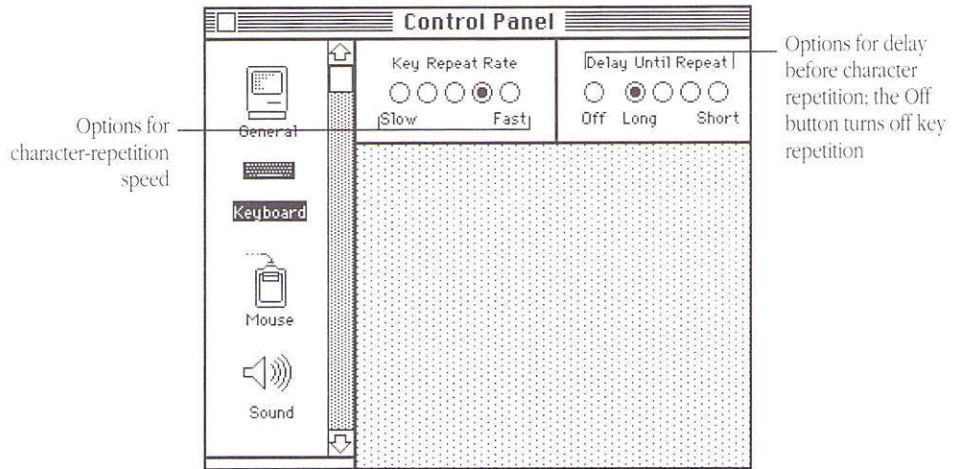
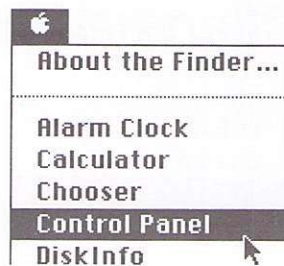

Figure 8-2 The Keyboard Control Panel

Setting the keys' repeat rate

On all Macintosh keyboards, holding down most keys causes the character to appear repeatedly on the screen until you release the key. You can adjust the rate of repetition from very slow to quite fast.



1 To set the repeat speed for a key held down, first choose Control Panel from the Apple menu.

The Control Panel opens, with the General section displayed.

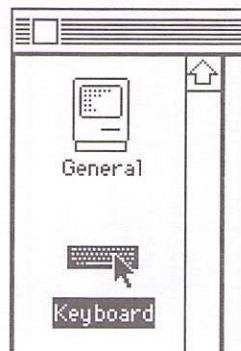

2 Scroll if necessary to locate the Keyboard icon, then click it to display the Keyboard section.

The Keyboard Control Panel appears. The pointer becomes a crosshair when you place it in the Key Repeat Rate area.

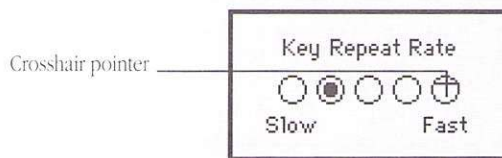

3 Click the button for the repeat rate you want.

Your choice remains in effect until you choose a different key repeat rate.

Setting the delay before keys repeat

You can adjust the keyboard's operation to your "touch" by setting the delay before a character begins repeating when a key is held down.

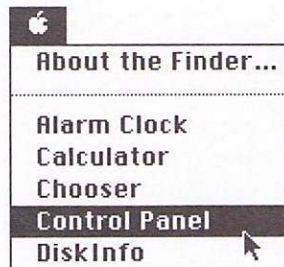

1 To set the delay until characters repeat when a key is held down, first choose Control Panel from the Apple menu.

The Control Panel opens, with the General section displayed.

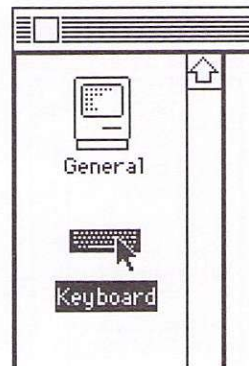

2 Scroll if necessary to locate the Keyboard icon, then click it to display the Keyboard section.

The Keyboard Control Panel appears. The pointer becomes a crosshair when you place it in the Delay Until Repeat area.

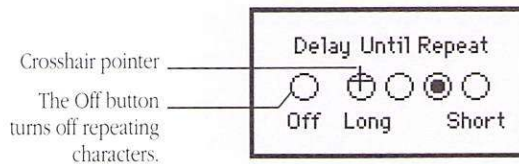

3 Click the button for the repeat delay you want.

Clicking the Off button overrides the character-repeat feature.

Your choice remains in effect until you choose a different delay option.

Adjusting sound and volume

You use the Sound Control Panel to set the speaker volume and to choose the sound the Macintosh makes when it signals you. (See Figure 8-3.)

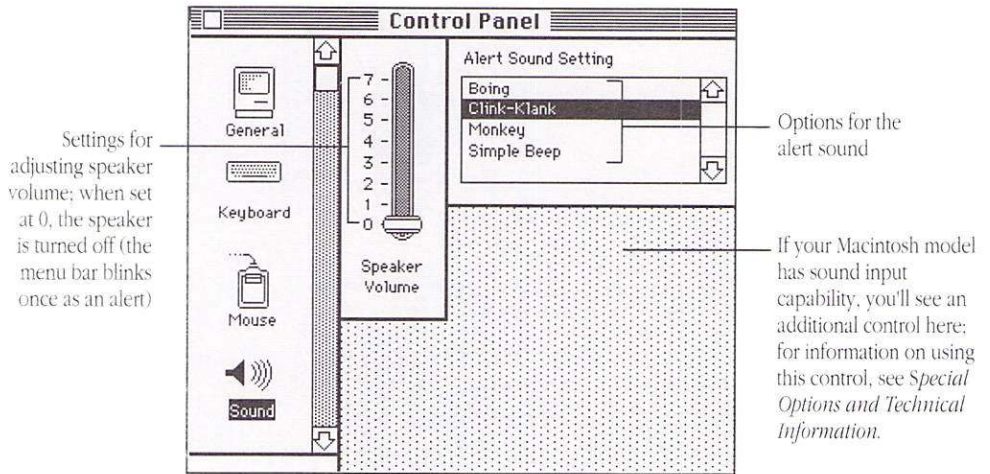
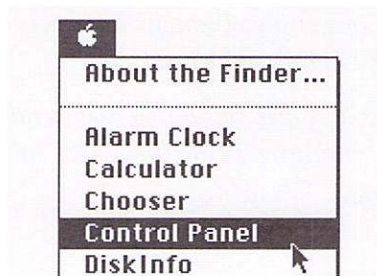

Figure 8-3 The Sound Control Panel

Setting the speaker volume

You can choose one of eight volume settings for the Macintosh's built-in speaker.



1 To adjust the speaker volume, first choose Control Panel from the Apple menu.

The General Control Panel appears.

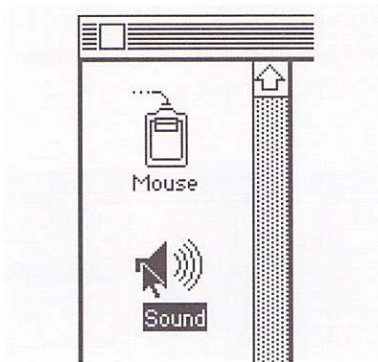

2 Scroll if necessary to locate the Sound icon, then click it to display the Sound section.

The Sound Control Panel appears. The pointer becomes a crosshair when you place it in the Speaker Volume area.

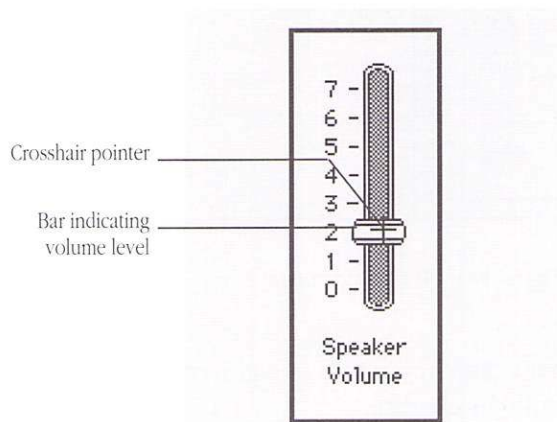

3 Using the crosshair pointer, drag the bar to the number you want for the level of speaker volume.

When you release the mouse button, the alert sound plays at the volume level you selected.

Your choice remains in effect until you choose a different level for speaker volume.

❖ *Speaker volume in two sections:* You can also set the speaker volume in the General Control Panel. ❖

➤ See also: • “Setting the Alert Sound” (next section)

Setting the alert sound

Many programs are designed to play a sound when an alert message is displayed or when you try to give a command that the Macintosh cannot recognize. You can choose one of several options for the alert sound.



1 To set the alert sound, first choose Control Panel from the Apple menu.

The General Control Panel appears.

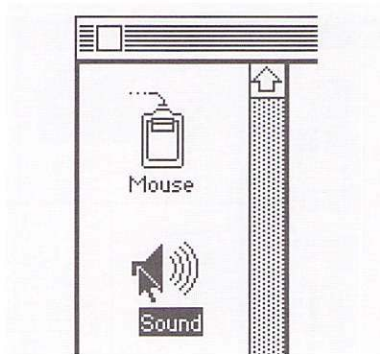

2 Scroll if necessary to locate the Sound icon, then click it to display the Sound section.

The Sound Control Panel appears. The pointer becomes a crosshair when you place it in the Alert Sound Setting area.

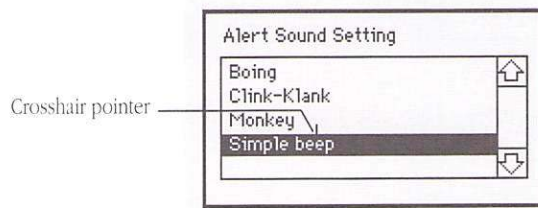

3 Scroll if necessary, then click the name of the sound you want.

When you release the mouse button, the selected sound plays.

Your choice remains in effect until you choose a different alert sound.

❖ *Flash instead of sound:* When the speaker volume is set to zero, the menu bar flashes in place of an alert sound. ❖

➤ *See also:* • “Setting the Speaker Volume” (previous section)

Setting time and date

The Macintosh has an internal clock that runs continuously. A battery inside the computer maintains the time and date when the machine is turned off.

You set the time and date in the General Control Panel. (See Figure 8-4.)

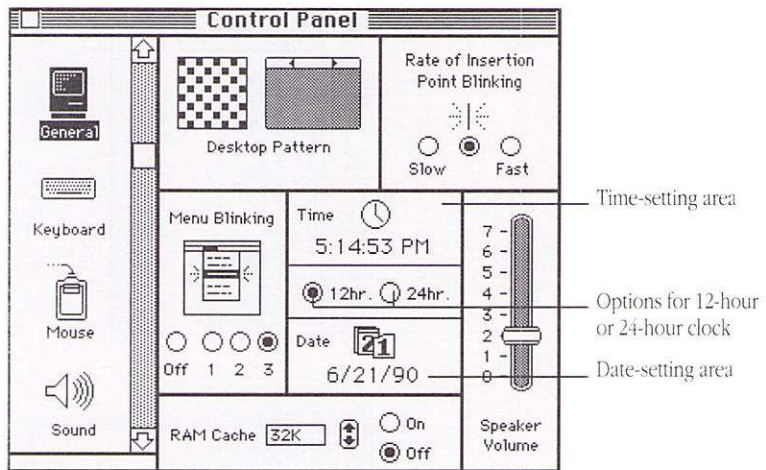
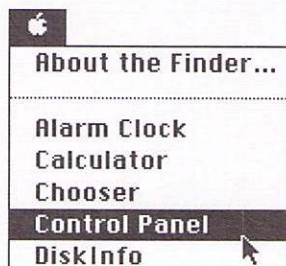

Figure 8-4 The General Control Panel showing time and date areas

➤ *See also:* • “Installing a Desk Accessory” in this chapter
• “Changing the Clock Battery” in Chapter 10

Changing the time

You can specify a standard 12-hour clock (showing A.M. and P.M. with the time) or a 24-hour clock when you set the time.



1 To set the time, first choose Control Panel from the Apple menu.

The General Control Panel appears. The pointer changes to a crosshair when you place it in the time area.

Crosshair pointer

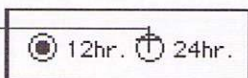

2 If you want to change the type of clock selected (12-hour or 24-hour), click the appropriate button.

The time changes in the Time area to reflect the type of clock selected.

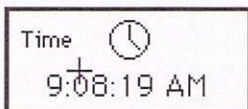

3 Click the part of the time you want to change (hours, minutes, or seconds).

The part of the time you click becomes highlighted, and small up and down arrows appear at the right.

Selected section
of the time

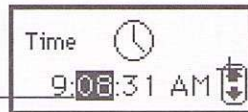

4 Click repeatedly on the up or down arrow until the time you want is displayed.

The selected part of the time changes in the direction of the arrow each time you click.

You can also type a new number for the time when it is selected.

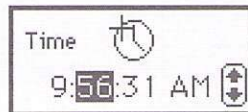

5 To save the new time, click the clock icon.

The clock icon becomes highlighted briefly, then the new time is displayed.

After you close the Control Panel, the time you set remains in effect until you change it.

❖ *Another way to set the time:* You can also set the time, as well as an alert time, in the Alarm Clock, a desk accessory that is part of the system software supplied with the Macintosh. ❖

Changing the date You change the date in much the same way as you change the time.

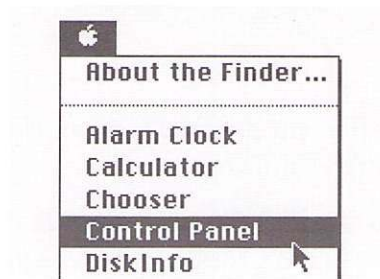

1 To set the date, first choose Control Panel from the Apple menu.

The General Control Panel appears. The pointer changes to a crosshair when you place it in the Date area.

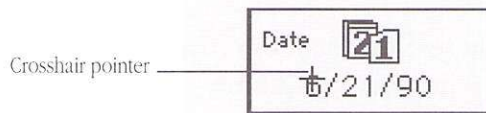

2 Click the part of the date you want to change (month, day, or year).

The part of the date selected becomes highlighted, and small up and down arrows appear at the right.

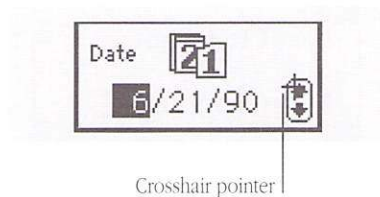

3 Click the up or down arrow repeatedly until the date you want is displayed.

The selected part of the date changes in the direction of the arrow each time you click.

You can also type a new number for the date when it is selected.

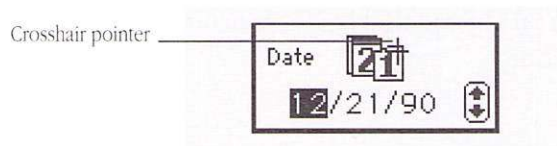

4 To save the new date, click the calendar icon.

The calendar icon becomes highlighted briefly, then the new date takes effect.

After you close the Control Panel, the date you set remains in effect until you change it.

❖ *Another way to set the date:* You can also set the date in the Alarm Clock, a desk accessory that is part of the system software supplied with the Macintosh. ❖

Setting an alert time with the Alarm Clock

You can set the Macintosh Alarm Clock desk accessory to alert you at a predetermined time.

The Alarm Clock is part of the system software and is usually installed when you install the system software. If necessary, you can install it with the Font/DA Mover.

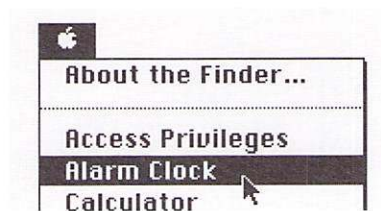

1 To set an alert time, first choose Alarm Clock from the Apple menu.

The Alarm Clock appears at the top right of the screen, just below the menu bar. It displays the current time on the system clock.

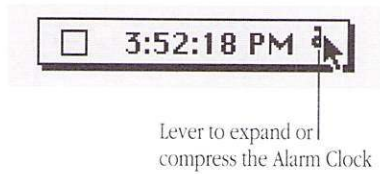

2 Click the upward-pointing lever to the right of the time.

The lever points downward, and the Alarm Clock expands to its full size.

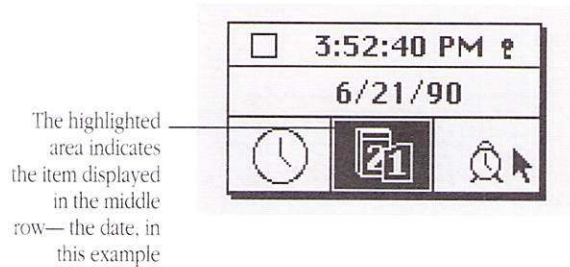

3 If necessary, click the alarm clock icon in the lower-right area to select it.

The alarm clock area is highlighted when you select it. (Skip this step if the alarm clock is already highlighted.) The time showing in the middle row is the last time to which the alarm was set.

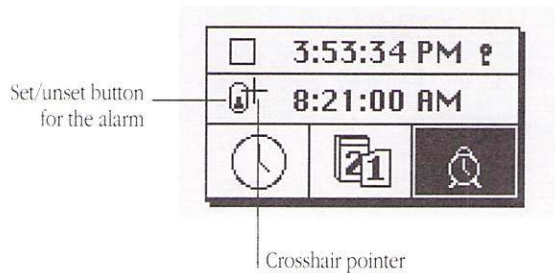

4 Click the button to the left of the time in the middle row to turn the alarm on.

The pointer becomes a crosshair when you place it in the middle row. When you click, the button moves up and the alarm clock icon changes to show a ringing alarm, indicating that the alarm is turned on. (Clicking again moves the button down and turns the alarm off.)

Button in the upper position indicates that the alarm is on.

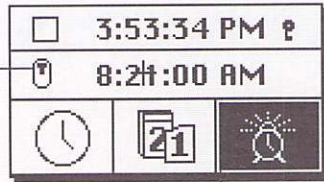

Icon showing ringing alarm

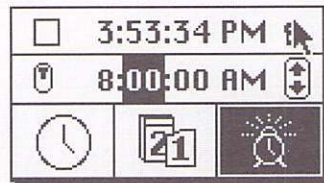

5 Click the part of the time you want to change.

The part of the time selected becomes highlighted, and small up and down arrows appear to the right of the time.

6 Click the up or down arrow repeatedly until the time you want is displayed.

The selected part of the time changes each time you click.

7 Click the lever at the right side of the top row to compress the Alarm Clock.

The alarm will not go off unless you click the lever to return to the compact clock, select another area of the clock, or click the close box.

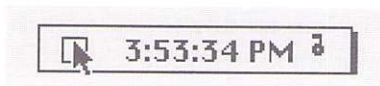

8 Click the close box to close the Alarm Clock.

When the system clock reaches the time set for the alarm, the alert sound plays once (the menu bar flashes once if the speaker volume is set to zero) and an alarm clock icon blinks alternately with the Apple icon at the left side of the menu bar. (See Figure 8-5.)

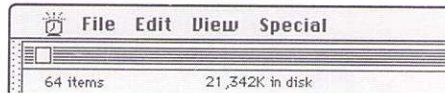

Figure 8-5 The alarm clock icon in the menu bar

After the alarm has gone off, you must open the Alarm Clock and turn the alarm off to stop the alarm clock icon blinking in the menu bar.

- ❖ *Setting the time and date:* You can also set the system clock's time and date in the Alarm Clock, by first selecting the time or date icon and then changing the numbers. ❖
- *See also:* • “Installing a Desk Accessory” in this chapter

Changing the look of the desktop

You can modify several aspects of the desktop's and screen's appearance with the Control Panel as well as with controls on the Macintosh or its monitor.

Three of these items—the desktop pattern, blinking of a chosen menu item, and blinking of the insertion point—are adjusted in the General Control Panel. (See Figure 8-6.)

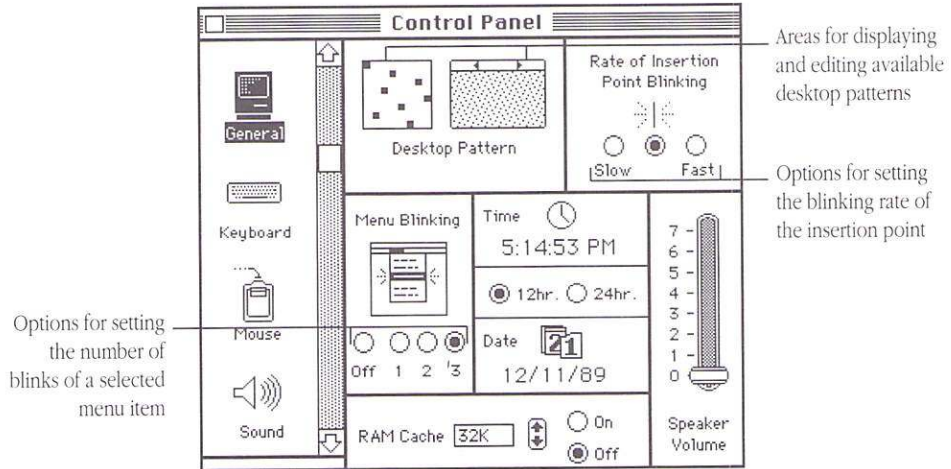
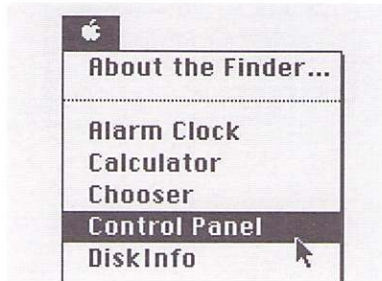

Figure 8-6 The General Control Panel showing desktop adjustments

Changing the pattern displayed on the desktop

You can choose from a variety of patterns provided for the Macintosh desktop, or you can create your own design by editing one of the patterns supplied.



1 To adjust the desktop pattern, first choose Control Panel from the Apple menu.

The General Control Panel appears. The pointer changes to a crosshair when you place it in the Desktop Pattern area.

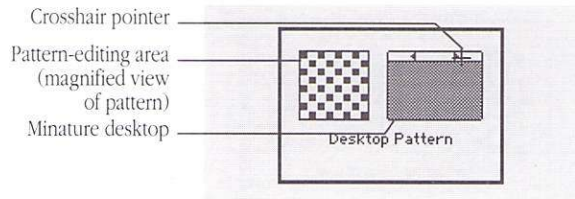

2 To see the patterns available, click either small arrowhead at the top of the miniature desktop on the right side of the Desktop Pattern area.

The pattern changes each time you click. Clicking the opposite arrowhead reverses the order of patterns displayed.

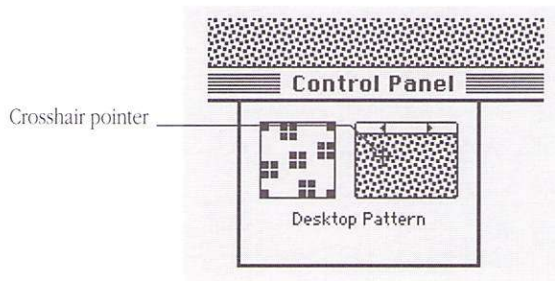

3 When you see a pattern you like, click the miniature desktop to see the new pattern on your full screen.

The new pattern replaces the current pattern for the desktop. If you decide not to keep that pattern, begin the selection process again.

Crosshair pointer

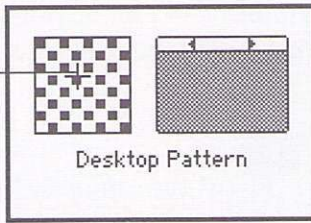

4 To edit a pattern, place the crosshair pointer in the pattern-editing area, then click where you want to make a change.

Tiny squares (called *pixels*) turn from black to white or white to black (or change color) when clicked. The changes you make when editing a pattern are displayed immediately in the miniature desktop.

Crosshair pointer

Edited pattern

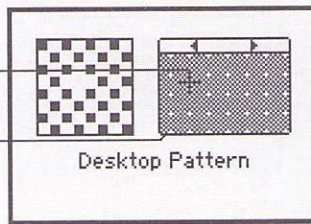

5 When you have finished editing, click in the miniature desktop to display the new pattern on your full screen.

After you close the Control Panel, the new pattern you selected or created remains in effect until you change it.

➤ See also: • “Changing the Colors or Shades of Gray in the Desktop Pattern” in this chapter

Adjusting the blinking of a selected menu item

Menu items are preset to blink three times when you choose them. You can reduce or eliminate the blinking of a chosen menu item in the General Control Panel.



1 To adjust the blinking of a chosen menu item, first choose Control Panel from the Apple menu.

The General Control Panel appears. The pointer changes to a crosshair when you place it in the Menu Blinking area.

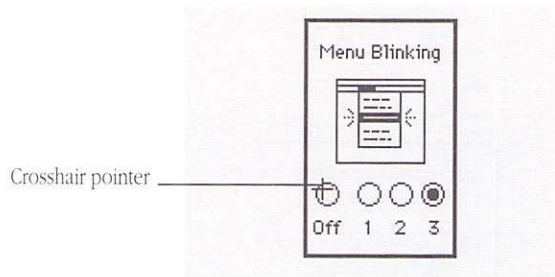

2 Click the button for the number of times you want the menu item to blink.

Clicking the Off button prevents a menu item from blinking.

After you close the Control Panel, the blinking option you selected remains in effect until you change it.

Adjusting the blinking of the insertion point

You can change the blinking rate of the insertion point—used to designate the place in a document or an icon name where you will add or change the content—in the General Control Panel.



1 To adjust the blinking rate of the insertion point, first choose Control Panel from the Apple menu.

The General Control Panel appears. The insertion point is blinking at the rate currently selected. The pointer changes to a crosshair when you place it in the Rate of Insertion Point Blinking area.

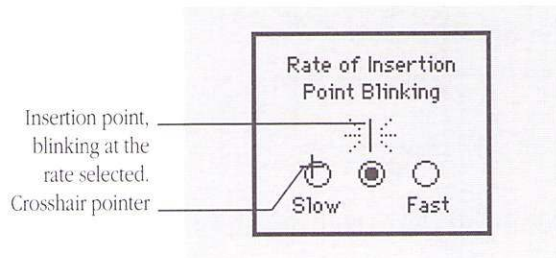

2 Click the button for the rate of blinking you want.

When you click, the insertion point changes to the rate of blinking you selected.

Indicating the relative positions of multiple monitors

If you use two or more monitors, you must indicate their relative positions so that the pointer can move from one monitor to another. You specify monitor positions in the Monitors Control Panel. (See Figure 8-7.)

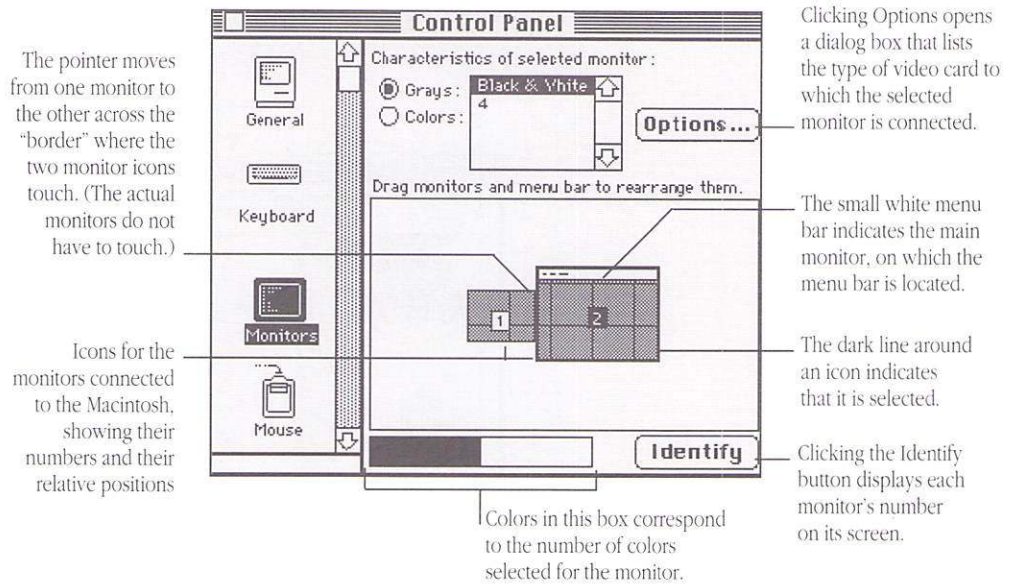
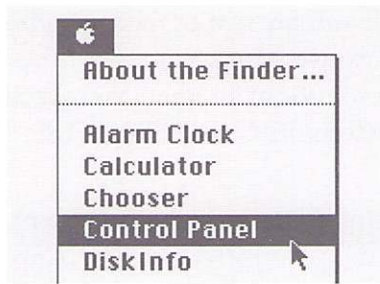

Figure 8-7 The Monitors Control Panel showing two monitors

The number of each monitor is determined by the location of the video card or built-in video socket to which it is connected. The monitor numbers remain the same unless you change the location of their video connections.



1 To specify monitor positions, first choose Control Panel from the Apple menu.

The General Control Panel appears.

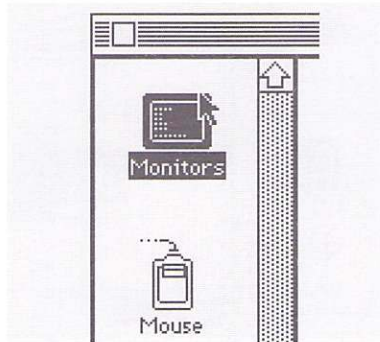

2 Scroll if necessary to locate the Monitors icon, then click it to display the Monitors section.

The Monitors Control Panel appears.

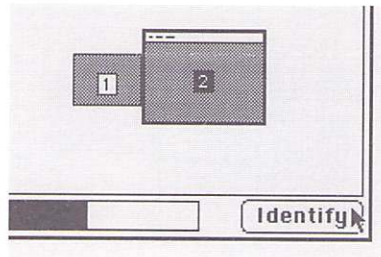

3 If necessary, check the numbers of your monitors by placing the pointer on the Identify button at the lower-right corner of the Control Panel and holding down the mouse button.

A large number appears in the center of each monitor's screen while the mouse button is held down; that number corresponds to the number of the icon in the Control Panel.

Skip this step if you don't need to verify the monitors' numbers.

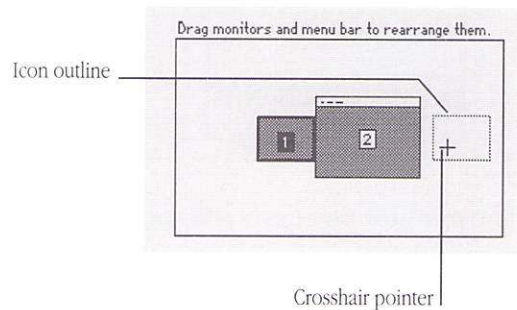

4 Drag the icon of the monitor whose position you want to adjust to a location on the screen that corresponds to that monitor's actual position.

Because you're adjusting the monitor's position relative to the other monitor or monitors near it, you can't move the icon away from the other icon or icons. If you drag the icon to an isolated location on the screen, it will snap back to border on the closest other icon when you release the mouse button.

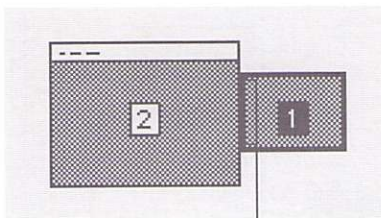

Border between monitors; the pointer moves from one monitor to the other only along this border on the actual monitors.

5 Release the mouse button when the outline of the icon you're repositioning is where you want it.

The icon appears at or near where you dragged its outline, with one side bordering the closest other icon.

If necessary, repeat steps 3 through 5 to adjust the relative positions of other monitors.



6 Choose Restart from the Special menu to implement the new monitor positions.

You don't have to close the Control Panel before choosing the Restart command.

The monitor positions you specified remain in effect until you change them.

After you have specified the monitor positions, the pointer moves from one screen to another across the borders where the monitors' icons touch in the Control Panel.

Designating a main monitor

You can designate a main monitor, where the Finder's menu bar will always be displayed.

- ❖ *Monitors of different sizes:* It's a good idea to make your larger monitor the main monitor. If the smaller one is the main monitor, some programs will restrict the window size to the size of the smaller monitor. ❖

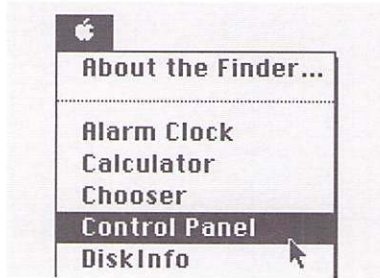

1 To designate a main monitor, first choose Control Panel from the Apple menu.

The General Control Panel appears.

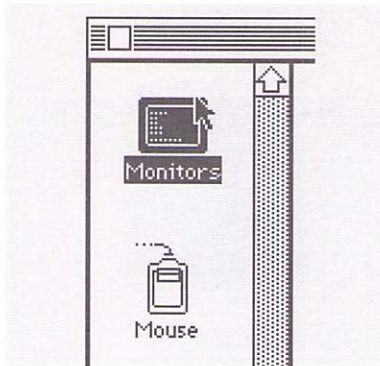

2 Scroll if necessary to locate the Monitors icon, then click it to display the Monitors section.

The Monitors Control Panel appears.

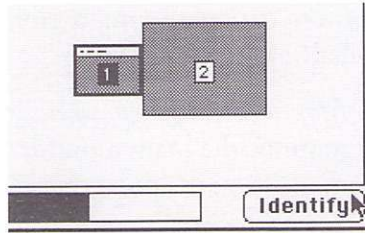

3 If necessary, check the numbers of your monitors by placing the pointer on the Identify button at the lower-right corner of the Control Panel and holding down the mouse button.

A large number appears in the center of each monitor's screen while the mouse button is held down; that number corresponds to the number of the icon in the Control Panel.

Skip this step if you don't need to verify the monitors' numbers.

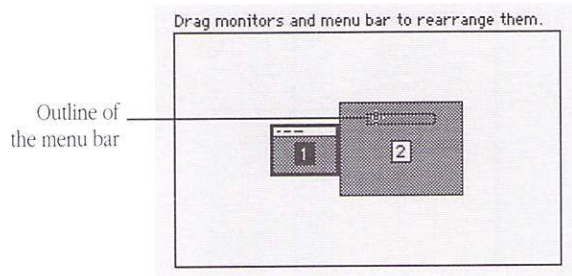

4 Drag the white menu bar from the top of one monitor icon to the icon of the monitor you want to be your main one.

An outline of the menu bar moves with the crosshair pointer as you drag.

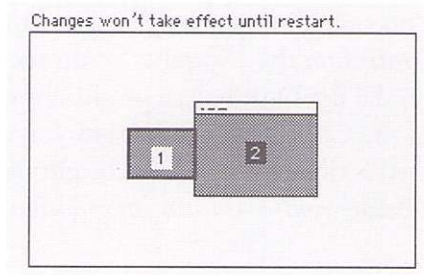

5 Release the mouse button when the menu bar's outline is where you want it.

The menu bar appears across the top of the new icon for the new main monitor.



6 Choose Restart from the Special menu to implement the new main monitor.

You don't have to close the Control Panel before choosing the Restart command.

The monitor you specified will be the main one until you change it in the Monitors Control Panel.

Adjusting screen brightness

You can adjust the brightness of most Macintosh models with a control on the computer or on the monitor. (If your Macintosh model does not have a brightness control, it has a special section of the Control Panel that lets you adjust screen brightness. For instructions on using the Brightness Control Panel, see *Special Options and Technical Information*.)

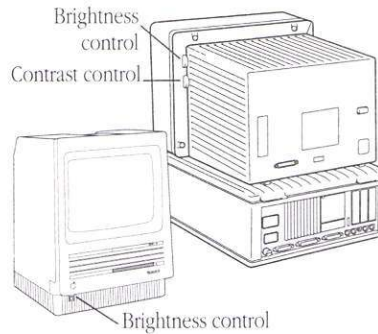

1 Locate the brightness control or controls on your Macintosh model or monitor. If your Macintosh has a separate monitor, check the monitor's manual for specific instructions.

Certain compact models (Macintosh Plus, Macintosh SE models) have one control on the front of the computer. Modular Macintosh models usually have two controls—brightness and contrast—on one side of the monitor. Some of these controls are marked with an icon of a sun.

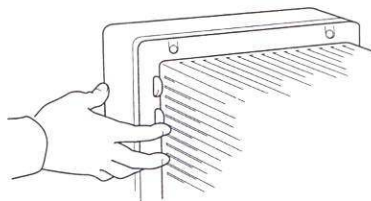

2 Turn the control dial or dials until the screen's appearance is satisfactory.

Designating colors or shades of gray

If your Macintosh model and its monitor can display color or multiple shades of gray, you can designate the number of colors or shades of gray to be displayed and then specify how the available colors or shades of gray will be used in highlighting, in the desktop pattern, and in icons.

Specifying the number of colors or shades of gray

You use the Monitors Control Panel to specify the number of colors or shades of gray displayed on your Macintosh. (See Figure 8-8.)

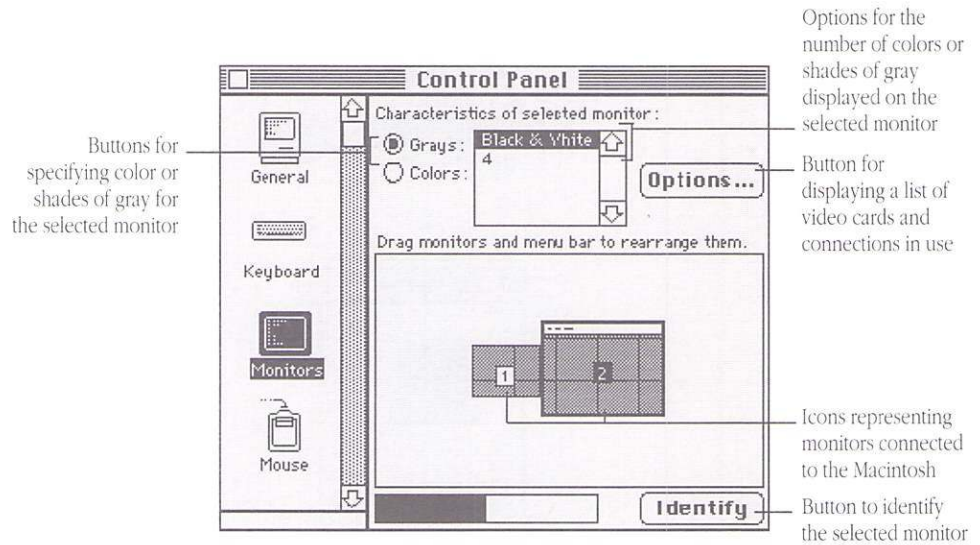
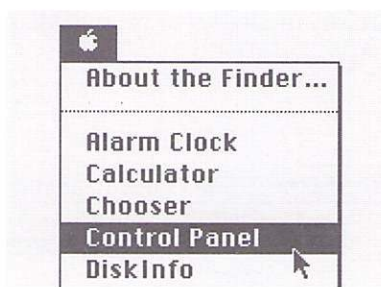

Figure 8-8 The Monitors Control Panel

The number of colors or shades of gray your Macintosh model can display depends on the type of video capability it has. Some Macintosh models require a video card to connect a monitor. Other models don't require a video card (because they have a built-in video connector), but they can use a video card if one is installed.



1 To specify the number of colors or shades of gray to be displayed on a monitor, first choose Control Panel from the Apple menu.

The General Control Panel appears.

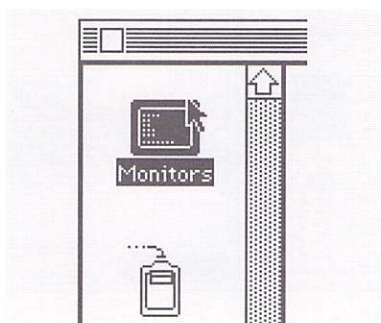

2 Scroll if necessary to locate the Monitors icon, then click it to display the Monitors section.

The Monitors Control Panel appears. The pointer becomes a crosshair when you place it in the monitor-position or monitor-characteristics area.

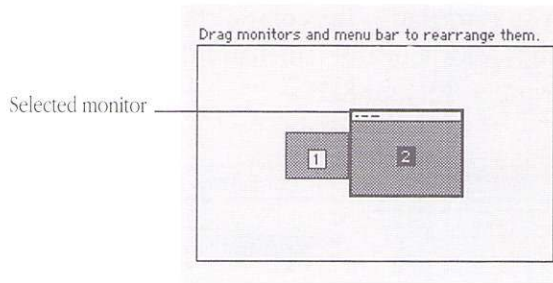

3 If you have more than one monitor, click the icon of the monitor for which you want to specify the number of colors or shades of gray.

The monitor is selected.

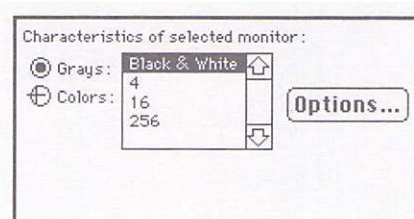

4 Click the Grays or the Colors button to specify the characteristics of the selected monitor.

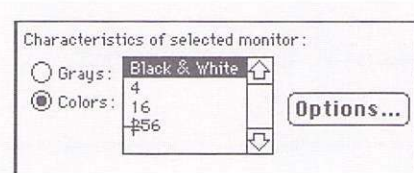

5 Click the number of colors or shades of gray you want displayed on the selected monitor.

The number of colors or shades of gray you specified remains in effect until you change it.

Changing the highlight color

You can change the color of the highlight on your screen, using the Color Control Panel and the color wheel dialog box. (See Figures 8-9 and 8-10.)

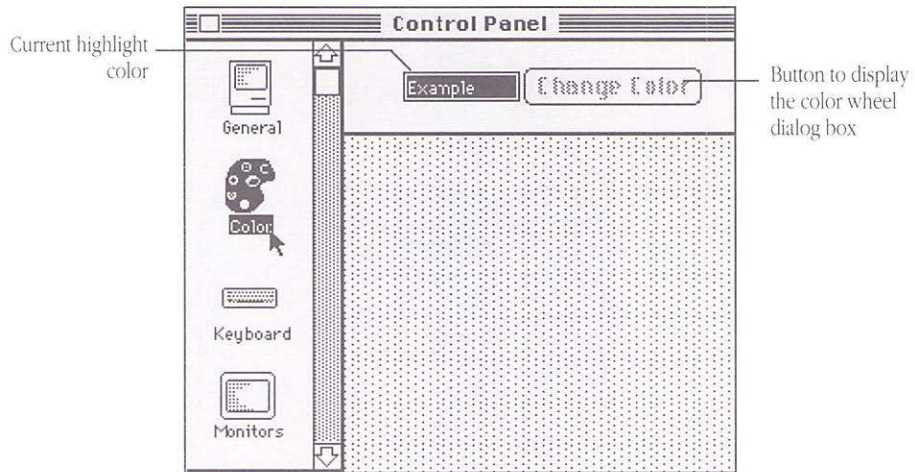

Figure 8-9 The Color Control Panel

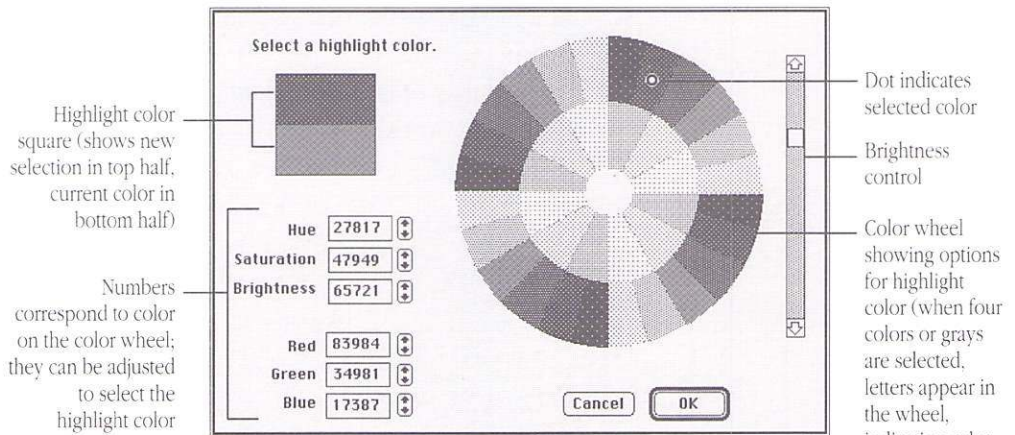
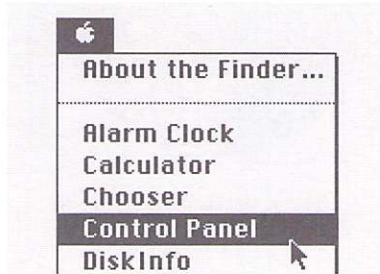

Figure 8-10 A simulation of the color wheel dialog box

To change the highlight color, the number of colors or shades of gray selected in the Monitors Control Panel must be four or more.



1 To change the highlight color, first choose Control Panel from the Apple menu.

The General Control Panel appears.

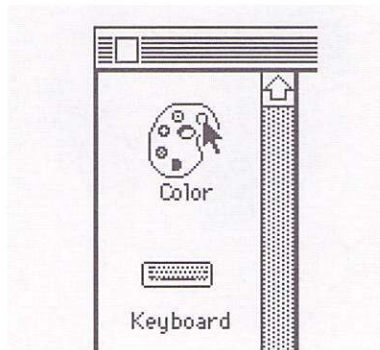

2 Scroll if necessary to locate the Color icon, then click it to display the Color section.

The Color Control Panel appears, showing an example of the current highlight color. The pointer becomes a crosshair when you place it in the color changing area.

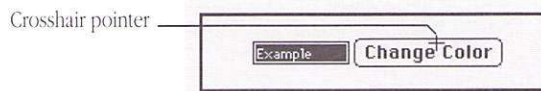

3 Click the Change Color button to display the color wheel dialog box.

The color wheel dialog box opens, showing the current highlight color and brightness.

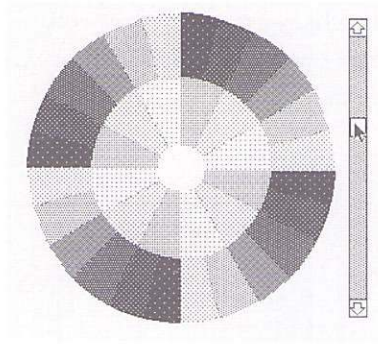

4 If necessary, change the brightness of the color wheel by dragging the scroll box up or down.

Scrolling up makes the color wheel brighter; scrolling down makes it darker.

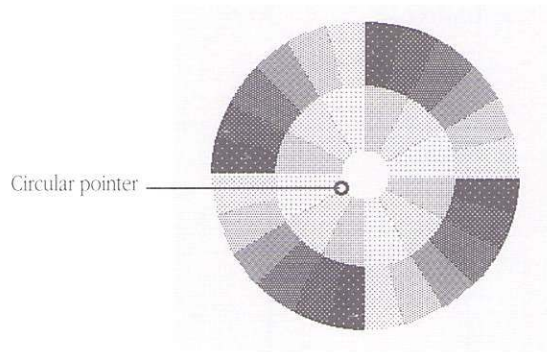

5 Place the pointer on the color wheel and click to select a new color or shade of gray.

The pointer is circular when it is on the color wheel.

The new color or shade of gray is displayed in the top half of the square at the upper left of the dialog box. The current highlight color or shade remains in the bottom half of the square for comparison.

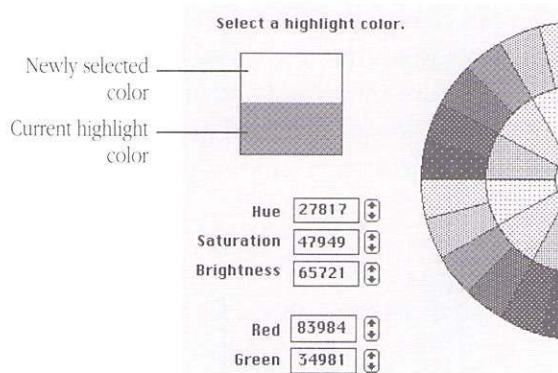

6 To experiment with other highlight colors or shades, drag the pointer around the color wheel or click at another point on the wheel.

A new color or shade is displayed in the upper half of the square as you drag or each time you click.

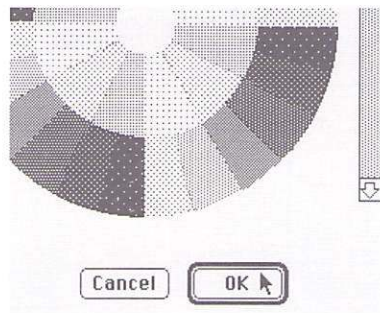

7 When you are satisfied with the highlight color or shade, click OK to confirm your choice.

The dialog box closes, revealing the Color Control Panel with the new highlight color displayed in the Example box.

After you close the Control Panel, the highlight color or shade of gray you specified remains in effect until you change it.

➤ *See also:* • “Specifying the Number of Colors or Shades of Gray” in this chapter

Changing the colors or shades of gray in the desktop pattern

You can change the colors or shades of gray displayed in the desktop pattern in the General Control Panel. You change colors in the pattern by editing one of the standard patterns provided, using the colors or shades of gray displayed in the Control Panel to replace the original colors or shades in that pattern.

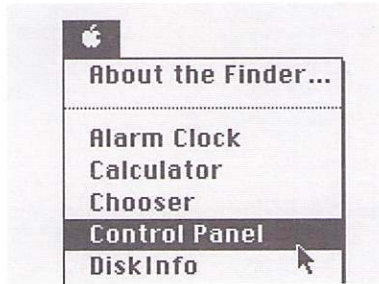

1 To change the colors or shades of gray in the desktop pattern, first choose Control Panel from the Apple menu.

The General Control Panel appears. The pointer becomes a crosshair when you place it in the Desktop Pattern area at the top center of the panel.

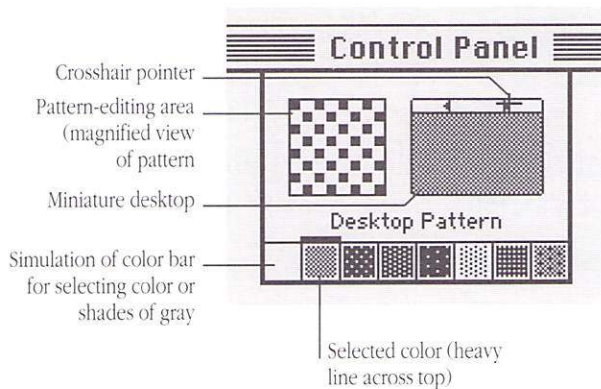

2 To see the patterns available, repeatedly click either small arrowhead at the top of the miniature desktop on the right side of the Desktop Pattern area.

The pattern changes each time you click. Clicking the opposite arrowhead reverses the order of patterns displayed.

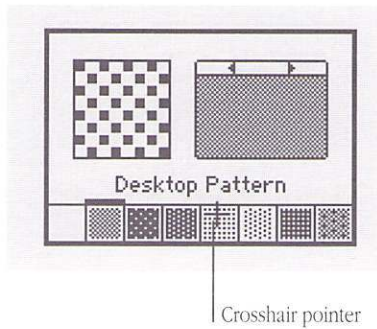

3 When you see a pattern you want to edit, click the color or shade of gray with which you want to replace some or all of the original colors.

The selected color or shade is indicated by a heavy line at its top edge.

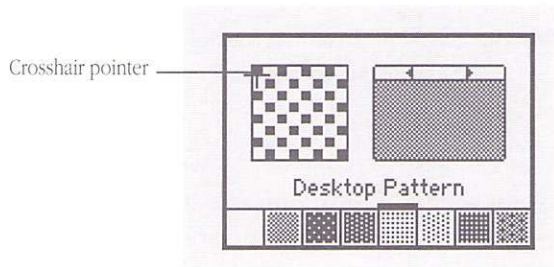

4 Click in the pattern-editing area where you want to make a change.

The dark or light squares (called *pixels*) change to the color you've selected when you click them. The changes you make when editing a pattern are displayed immediately in the miniature desktop.

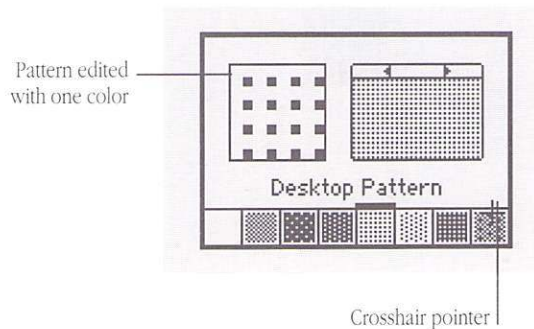

5 If you want to edit with another color or shade of gray, select that color or shade, and then click the pixels you want to change to that color or shade.

Clicking a pixel once changes it to the selected color or shade; clicking it a second time restores its original color.

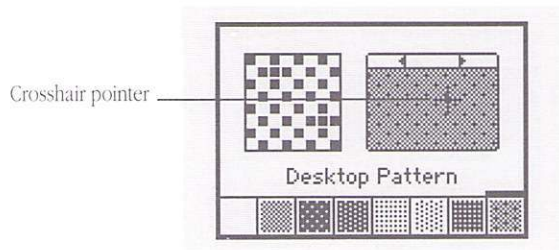

6 When you have finished editing, click in the miniature desktop to display the new pattern on your full screen.

After you close the Control Panel, the number of colors or shades of gray you specified remains in effect until you change it.

➤ *See also:* • “Changing the Pattern Displayed on the Desktop” in this chapter

Designating the color of icons

You can easily change an icon’s color or shade of gray in the Color menu. This menu is available only if your Macintosh is capable of displaying color or shades of gray and if you have specified at least 16 colors or shades of gray in the Monitors Control Panel.

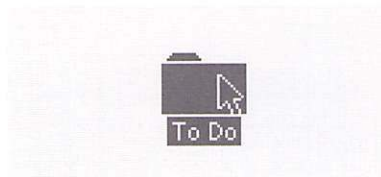

1 To change an icon’s color or shade of gray, first click the icon to select it. The icon becomes highlighted.

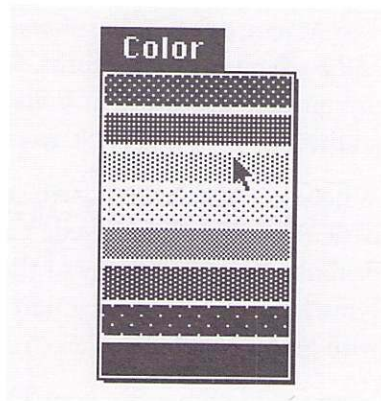

2 Choose the color or shade of gray you want from the Color menu.

The icon's color or shade changes to the one selected.

The icon retains the new color or shade of gray until you change it.

❖ *Viewing icons by color:* Macintosh models that can display color or shades of gray include an option for organizing files by icon color in the View menu. ❖

➤ *See also:*

- “Specifying the Number of Colors or Shades of Gray” in this chapter
- “Displaying Documents by Name, Size, Date, Kind, or Color of Icon” in Chapter 5

Moving fonts and desk accessories

The Macintosh system software includes several desk accessories and a selection of type fonts. Independent manufacturers and user groups or computer bulletin boards provide many additional fonts and desk accessories.

When you install the system software, a core set of fonts and desk accessories is installed. You can add more desk accessories or fonts—or remove any of the ones already installed—with the Font/DA Mover, another part of the system software supplied with your Macintosh.

Figure 8-11 shows the Font/DA Mover's primary dialog box.

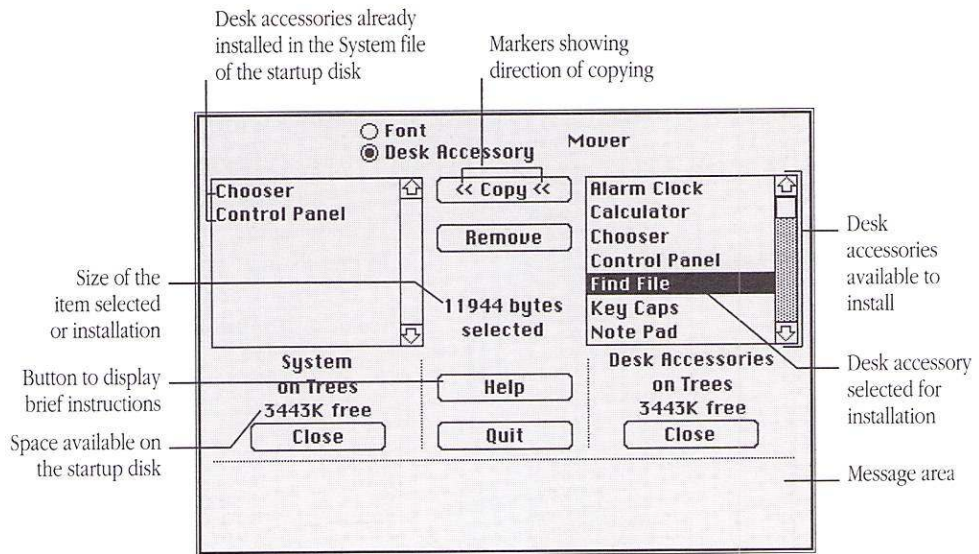

Figure 8-11 The Font/DA Mover showing desk accessories

Installing a font The Font/DA Mover and a file of fonts are supplied on the system software disks with the Macintosh. (See Figure 8-12.)

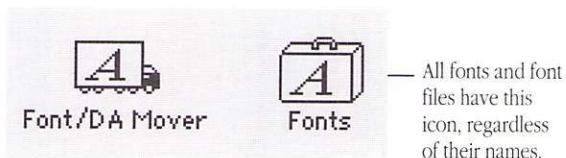
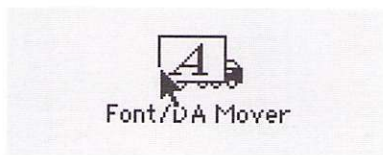

Figure 8-12 The Font/DA Mover and fonts file

Locate the disk or disks containing these files (or the font file you want to use) if you do not have them on your startup disk already.



1 To install a font, first open the Font/DA Mover by double-clicking its icon.

The Font/DA Mover opens, with the Font option selected in its window. The box on the left shows a list of the fonts currently installed in the System file of the startup disk.

If you want to install a font that is on a different disk, click the Close button, then use the Open button that replaces it to open the System file on the other disk.

Fonts installed in the System file (numbers indicate type size for screen display)

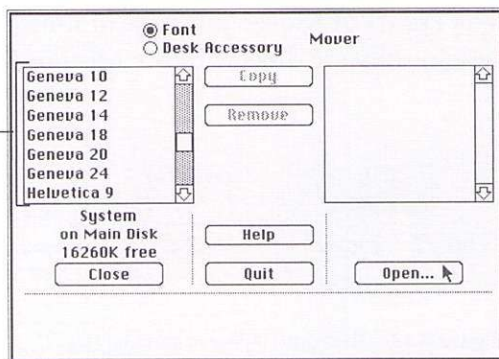

2 Click the Open button below the empty list box on the right side of the window.

A directory dialog box appears, with which you locate and open a fonts file.

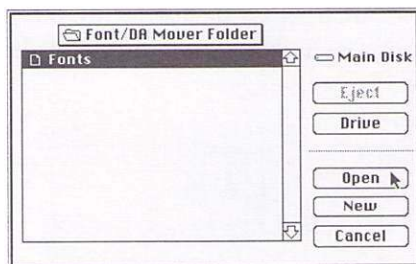

3 If necessary, use the Drive, Eject, and Open buttons to locate the fonts file you want, select the file's name, then click Open.

The dialog box closes, and the fonts in the file are listed in the box at the right side of the Font/DA Mover window.

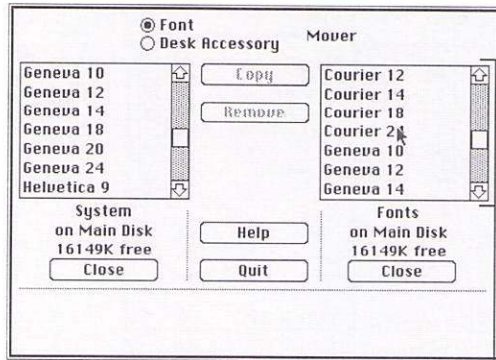

Fonts available in the fonts file just opened

4 Scroll if necessary, then select the font you want to install by clicking its name in the list on the right.

Small markers appear on the Copy button, showing the direction that the selected item will move. A sample of the font appears in the message area at the bottom of the window, and the amount of disk space occupied by the font is displayed between the two list boxes. If you select more than one font from the list (by Shift-clicking), the combined size of your selection is displayed, but no sample appears in the message area.

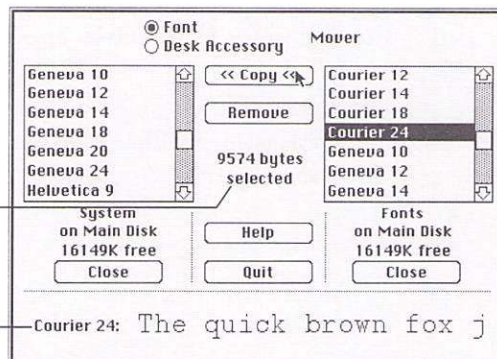

Size of the selected font

Sample of the selected font

5 Click the Copy button to add the selected font or fonts to your System file's fonts.

The name or names of the new fonts appear in the list on the left in alphabetical order when copying is completed.

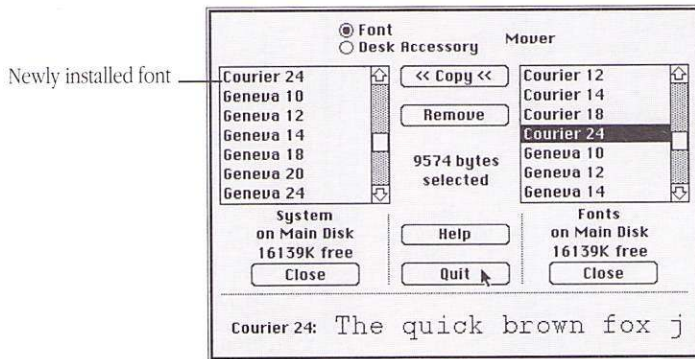

6 Click the Quit button at the bottom center of the window when you have finished installing fonts.



7 If you're using MultiFinder, choose Restart from the Special menu.

By restarting, you ensure that the new fonts will be available. You can skip this step if you're not using MultiFinder.

❖ *Copying fonts from one file to another:* You can also copy fonts from one System or fonts file to another System or fonts file. ❖

➤ *See also:* • "Managing Multiple Programs Using MultiFinder" in Chapter 3

Removing a font

You may need to remove one or more fonts to make more room on a startup disk. You use the Font/DA Mover to remove fonts.

If you're using MultiFinder, you can't remove fonts from the System of the startup disk. Start up with a different system disk, then use the Font/DA Mover to open the System of the disk from which you want to remove fonts and proceed according to the steps that follow.

- ❖ *Saving a font when you remove it:* If you want to remove a font and be certain that you still have a copy of it, you can use the Font/DA Mover to copy that item to a separate fonts file, and then remove it from the System. ❖

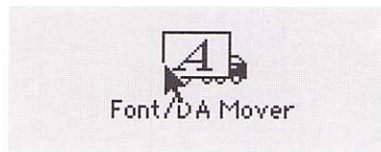

1 To remove a font, first open the Font/DA Mover by double-clicking its icon.

The Font/DA Mover's window opens, with the Font option selected. The box on the left shows a list of the fonts currently installed in the System file of the startup disk.

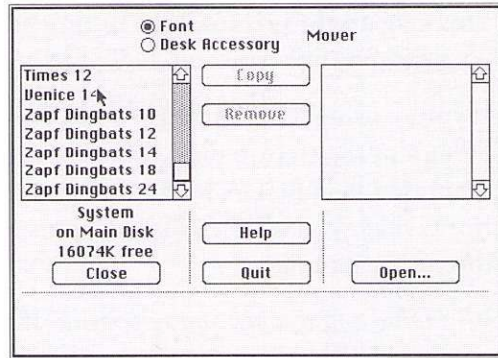

2 Scroll if necessary, then click the name of the font you want to remove in the list on the left.

A sample of the font is displayed in the message area at the bottom of the window, and the space the item occupies on the disk is displayed between the two list boxes. If you select more than one font from the list (by Shift-clicking), the combined size of your selection is displayed, but no sample appears in the message area.

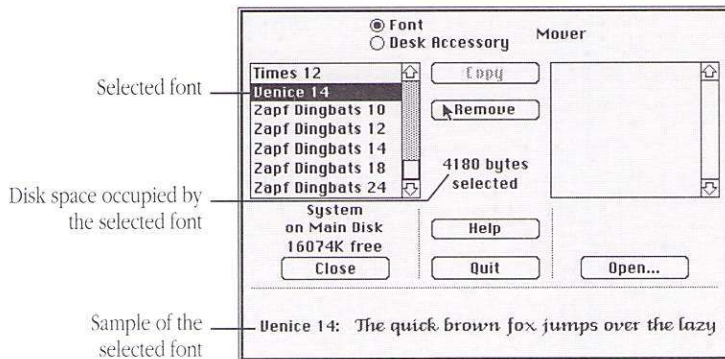

3 Click the Remove button to remove the selected item or items from your System's fonts.

An alert dialog box appears, asking you to confirm or cancel the action.

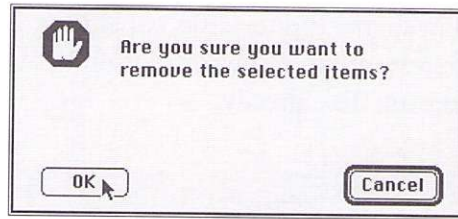

4 Click the OK button to proceed with removal of the selected font.

If you change your mind, you can use the Cancel button to stop the action.

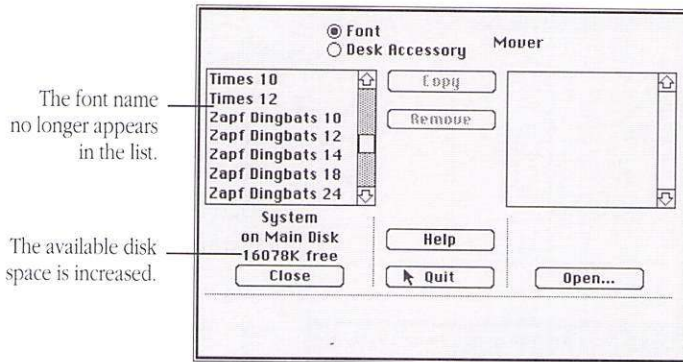

The font name no longer appears in the list.

The available disk space is increased.

5 Click the Quit button at the bottom center of the window when you have finished removing fonts.

➤ See also: • “Creating a File of Desk Accessories or Fonts” in this chapter

Installing a desk accessory

The Font/DA Mover and a file of desk accessories are supplied on the system software disks with the Macintosh. (See Figure 8-13.)



Figure 8-13 The Font/DA Mover and desk accessories file

Locate the disk or disks containing these files (or the desk accessory file you want to use) if you do not have them on your startup disk already.

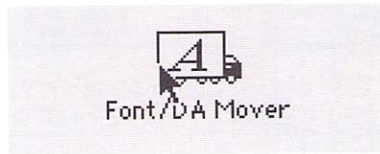

1 To install a desk accessory, first open the Font/DA Mover by double-clicking its icon.

The Font/DA Mover opens, with the Font option selected in its window. The box on the left shows a list of the fonts currently installed in the System of the startup disk.

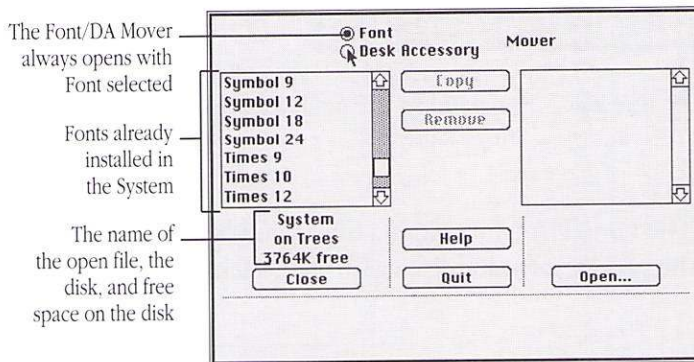

2 Click the Desk Accessory button at the top of the window.

The list on the left changes to the desk accessories currently installed in the System file on the startup disk.

If you want to install a desk accessory on a different disk, click the Close button, then use the Open button that replaces it to open the System file on the other disk.

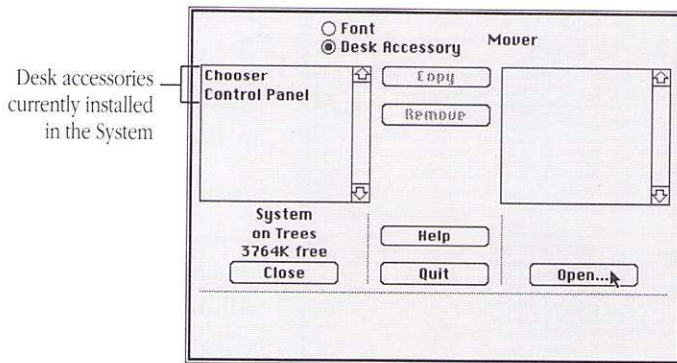

3 Click the Open button below the empty list box on the right side of the window.

A directory dialog box appears with which you locate and open a file of desk accessories.

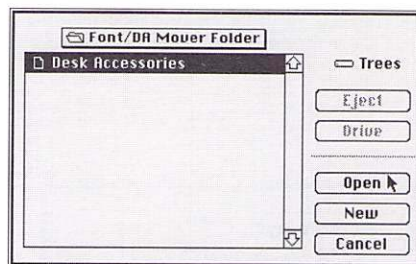

4 If necessary, use the Drive, Eject, and Open buttons to locate the desk accessories file you want, select the file's name, and then click Open.

The dialog box closes and the desk accessories in the file are listed in the box at the right side of the Font/DA Mover window.

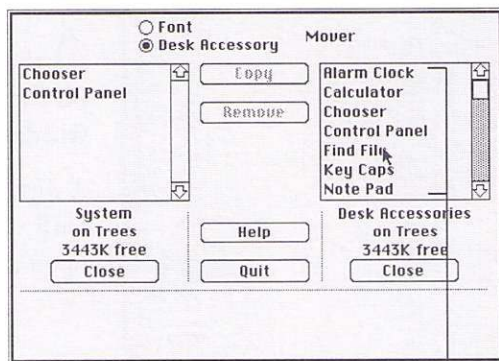

Desk accessories in the file just joined

5 Select the desk accessory you want to install by clicking its name in the list on the right.

Small markers appear on the Copy button, showing the direction that the selected item will move. The size of the item is displayed between the two list boxes. If you select more than one desk accessory from the list (by Shift-clicking), the combined size of your selection will be displayed.

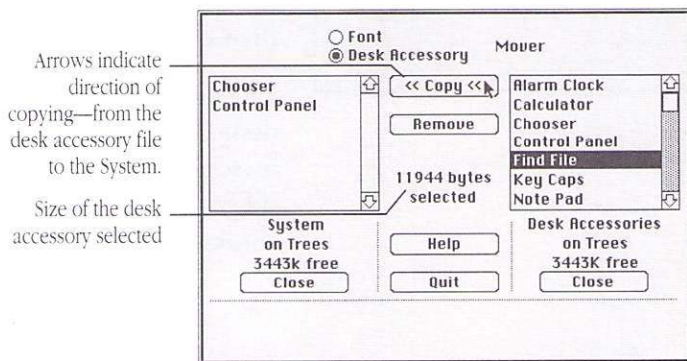

Arrows indicate direction of copying—from the desk accessory file to the System.

Size of the desk accessory selected

6 Click the Copy button to add the selected item or items to your System's desk accessories.

The item or items are copied into the System. The name or names of the new desk accessories appear in the list on the left in alphabetical order.

The name of the desk accessory installed in the System appears in the list when copying is completed.

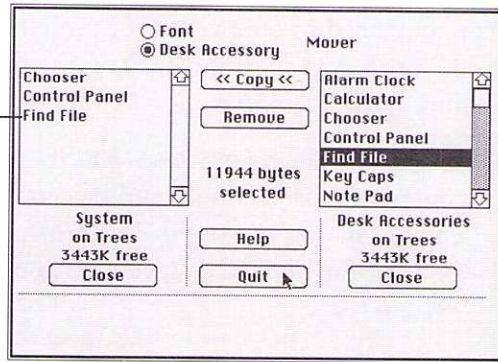

7 Click the Quit button at the bottom center of the window when you have finished installing desk accessories.



8 If you're using MultiFinder, choose Restart from the Special menu.

By restarting, you ensure that the new desk accessories will be available in the Apple menu. Skip this step if you're not using MultiFinder.

❖ *Starting the Font/DA Mover with the Desk Accessory option selected:* If you hold down the Option key when you start the Font/DA Mover, the Desk Accessory option is automatically selected. ❖

➤ *See also:* • "Managing Multiple Programs Using MultiFinder" in Chapter 3

Removing a desk accessory

You may need to remove one or more desk accessories to make more room on a startup disk. You use the Font/DA Mover to remove desk accessories.

- ❖ *Saving a desk accessory when you remove it:* If you want to remove a desk accessory and be certain that you still have a copy of it, you can use the Font/DA Mover to copy that item to a separate desk accessories file and then remove it from the System. ❖



1 To remove a desk accessory, first open the Font/DA Mover by double-clicking its icon.

The Font/DA Mover opens, with the Font option selected in its window. The box on the left shows a list of the fonts currently installed in the System of the startup disk.

The Font/DA Mover always opens with Font selected

Fonts installed in the System

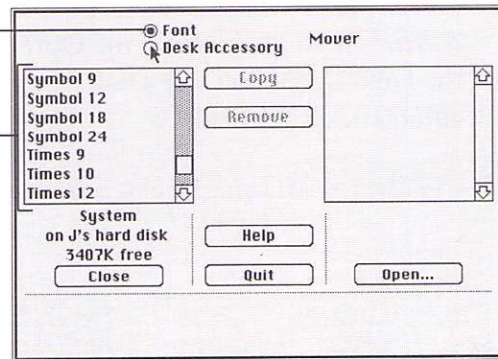

2 Click the Desk Accessory button at the top of the window.

The list on the left changes to the desk accessories currently installed in the System file on the startup disk.

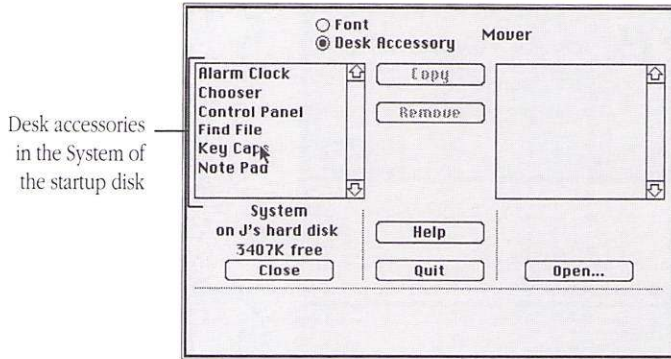

3 Select the desk accessory you want to remove by clicking its name in the list on the left.

The size of the item is displayed between the two list boxes. If you select more than one desk accessory from the list (by Shift-clicking), the combined size of your selection will be displayed.

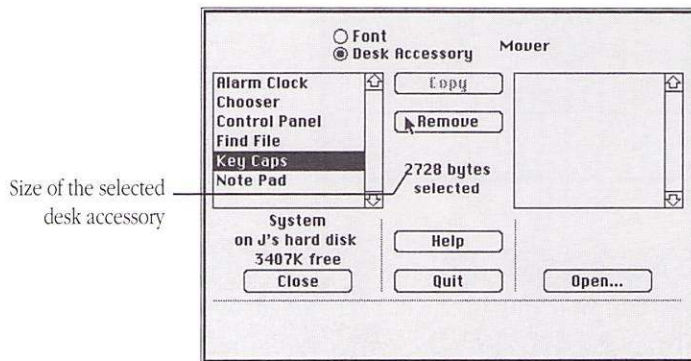

4 Click the Remove button to remove the selected item or items from your System's desk accessories.

An alert dialog box appears, asking you to confirm or cancel the action.

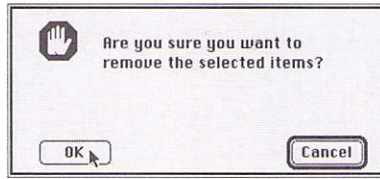

5 Click the OK button to proceed with removal of the selected desk accessory.

If you change your mind, you can use the Cancel button to stop the action.

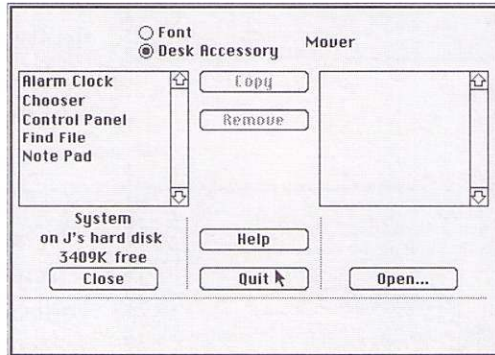

6 Click the Quit button at the bottom center of the window when you have finished removing desk accessories.

Creating a file of desk accessories or fonts

When you move desk accessories and fonts into and out of the System on a startup disk, you can easily create the special types of files used to store these items. Figure 8-14 shows the icons for a desk accessories file and a fonts file.



Figure 8-14 The icons for a desk accessories file and a fonts file

You use the Font/DA Mover to create these files.



1 To create a fonts file, first open the Font/DA Mover by double-clicking its icon.

The Font/DA Mover opens, with the Font option selected in its window. The box on the left shows a list of the fonts currently installed in the System file of the startup disk.

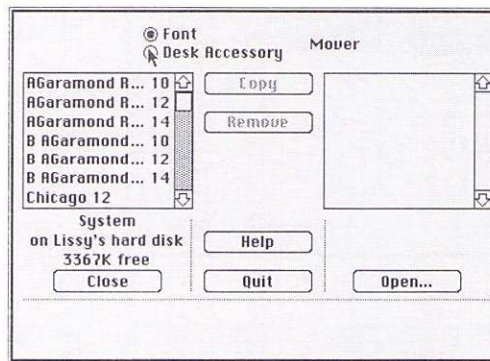

2 If you want to create a desk accessories file, click the Desk Accessory button.

Skip this step if you want to create a fonts file.

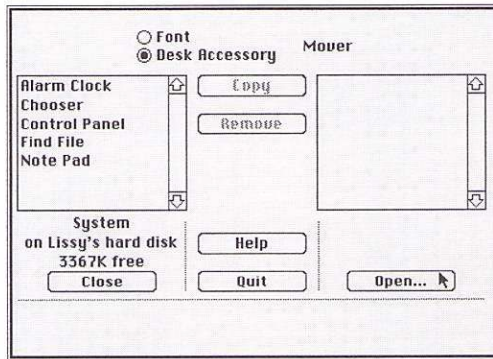

3 Click the Open button below the empty list box on the right side of the window.

A directory dialog box appears, in which you specify the file to open.

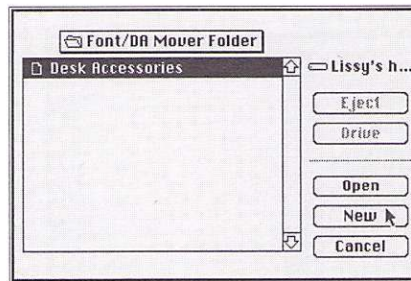

4 Click the New button to create a new file.

Another directory dialog box appears, in which you name the new file. An insertion point is blinking in the name box.

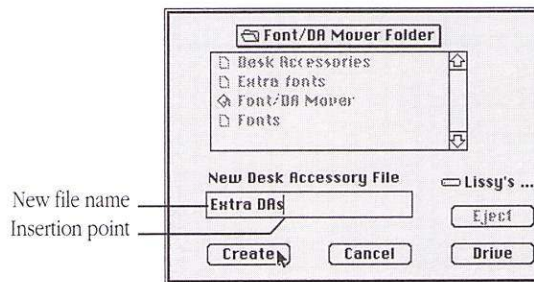

5 Type a name for the new file, then click Create to create the new file.

The dialog box closes, again revealing the Font/DA Mover window. The new file is open on the right side of the window.

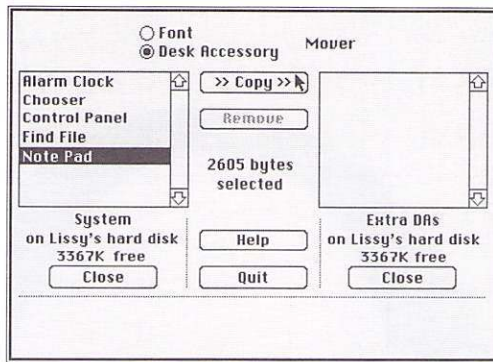

6 Copy the item or items you want to move into the new file.

If you don't copy at least one font or desk accessory into the new file, that file will not be saved when you finish using the Font/DA Mover.

When you have finished copying the item or items you want to store in the new file, remove any of them you no longer want in the System, then quit the Font/DA Mover.



Expanding Your Macintosh System

The Macintosh is the heart of a powerful and versatile computer system. This system can include such external devices as disk and tape drives, printers, multiple monitors, a scanner, a modem, a graphics tablet, and audio devices. All of these devices can be connected to the computer when it is originally set up or added later to expand its power.

The Macintosh can be expanded internally by installing additional memory and—in some models—coprocessor cards, specialized video and graphics cards, memory cache cards, and communications cards.

This chapter provides an overview of hardware connections and component installation for all Macintosh models. When you are connecting a specific device to your Macintosh, be sure to follow the detailed instructions that came with your Macintosh model and with the device itself.

Connecting SCSI devices

All Macintosh models have a socket, or port, for connecting devices that use the Small Computer System Interface (SCSI). The SCSI port permits high-speed communication between the computer and the device. (SCSI is commonly pronounced “skuh-zee.”)

Among the SCSI devices that are commonly used with the Macintosh are internal and external hard disk drives, tape backup drives, CD-ROM drives, scanners, and printers.

Because SCSI devices can be connected to one another, or *daisy-chained*, rather than having to be connected directly to the computer, the Macintosh can support up to seven of these devices, including one internally.

Setting the SCSI device number

Each SCSI device has an ID number from 0 to 7 that you can change if necessary. Apple assigns each type of SCSI device it manufactures a number at the factory; in most instances, you should not need to change the number unless two of the devices in your system have the same number.

The Macintosh uses the ID number to assign each device a priority on a chain of SCSI devices. The higher the number, the higher the device's priority; the computer itself is number 7 and an Apple internal hard disk is number 0 (so nothing else can have those numbers). The devices you use most often should have the highest priority numbers.

- ▲ **Warning:** Be sure to change the ID number of one device if you have two SCSI devices with the same ID number. You could lose information on one or both devices if you try to use two SCSI devices with the same ID number. ▲

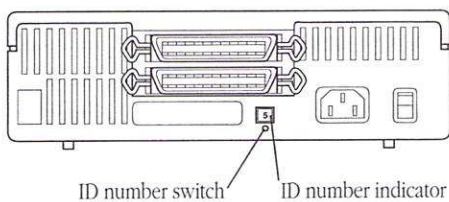

1 With the SCSI device turned off and unattached to anything, locate the ID number and the ID number switch on the back panel of the device.

The preset number is showing.

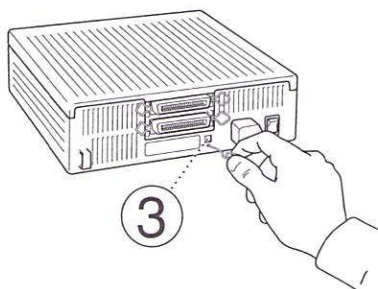

2 Insert the point of a pushpin or an opened paper clip into the ID number switch and push gently until the number you want is showing.

The number increases to 7, then starts over at 0. Some devices have blank spaces between the numbers 7 and 0.

Daisy-chaining SCSI devices

SCSI devices can be linked together by cables to form a chain. The arrangement of devices in a SCSI chain does not determine their priority in communicating with the Macintosh; the devices' ID numbers determine priority.

To assure accurate transmission of information to and from the computer and the SCSI devices connected to it, you must place special connectors, *SCSI cable terminators*, at each end of a SCSI chain. (See Figure 9-1.)

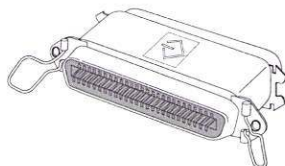

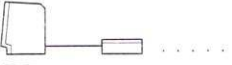
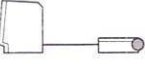

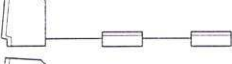
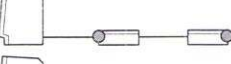
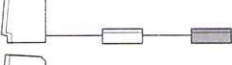

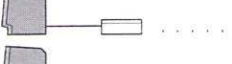
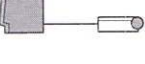

Figure 9-1 SCSI cable terminator





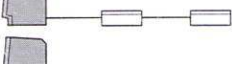
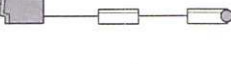
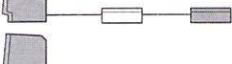
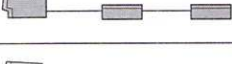
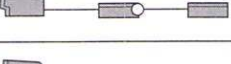

Every Macintosh that has an internal Apple hard disk has a built-in SCSI terminator. For most models, the computer's internal terminator serves as the terminator for one end of the SCSI chain. If you have a Macintosh Portable, consult the *Macintosh Portable Handbook* for instructions about using terminators. You may need to use an additional terminator if you connect an external SCSI device to the Macintosh Portable.

You use terminators with *SCSI cables*, which connect the first device to the computer and other devices in a chain to each other.

Table 9-1 shows how to arrange the SCSI cables and terminators with several different configurations of equipment.

Table 9-1 Guidelines for using terminators when connecting SCSI devices to the Macintosh

If		then	
If		then	no action needed
If		then	
If		then	no action needed
If		then	no action needed
If		then	
If		then	no action needed
If		then	
If		then	no action needed
If		then	

	Macintosh without an internal hard disk		Macintosh with an internal hard disk
	Peripheral without an internal terminator		Peripheral with an internal terminator
	Add terminator between device and cable into device		Add terminator to connector not used for cable
	Remove terminator		

When you connect a SCSI cable to the Macintosh, you place the cable in the SCSI port on the computer's back panel. You can recognize the SCSI port by its icon, shown in Figure 9-2.



Figure 9-2 The SCSI icon

- △ **Important:** Always turn on your SCSI device before turning on your computer. △

Connecting non-SCSI devices

The Macintosh has several ports to which you can connect other types of peripheral devices. Each port is marked by a distinctive icon on the back panel of the computer and on the Apple cable that connects the appropriate device to it.

Connecting a printer

You connect most printers to the Macintosh through the *printer port*. This port is a *serial* port, meaning that it transmits the *bits* that make up the computer's information in single file, or serially.

Some printers, such as the LaserWriter IINT and LaserWriter IINTX, are designed for use on the AppleTalk network system. Others, such as the ImageWriter II and ImageWriter LQ, can operate either as stand-alone printers for one Macintosh or as LocalTalk devices. (*LocalTalk* is the name for work-group networks that are part of the AppleTalk network system.)

All these printers connect to the Macintosh's printer port. Exceptions are the Personal LaserWriter SC and the LaserWriter IISC which connect to the SCSI port.

If necessary, a printer can be connected to the modem port, which is also a serial port. You indicate the port to which a printer is connected in the Chooser.

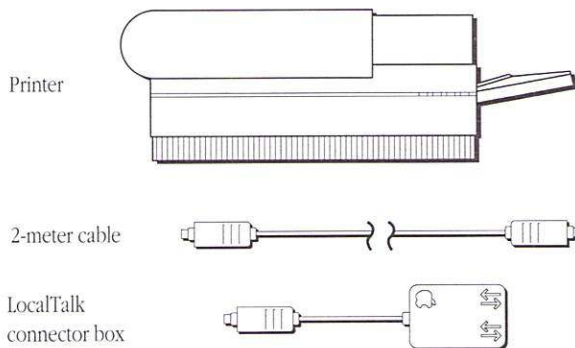

1 Assemble the components you need: printer, appropriate cable, LocalTalk connector boxes if needed, and setup instructions.

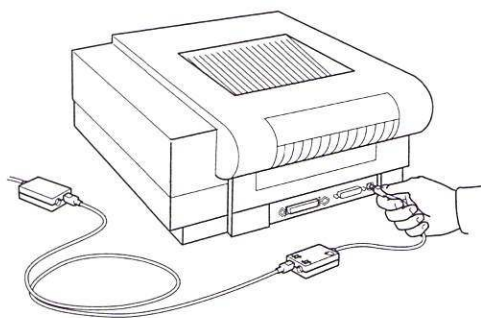

2 Attach the larger connector on the printer cable to the printer, or attach one end of the LocalTalk cable to the connector box and attach the printer's LocalTalk connector to the printer. (Consult the printer's setup instructions for details.)

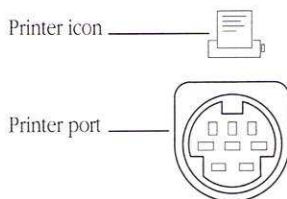

3 Attach the small, round connector on the printer cable to the printer port on the back panel of your Macintosh, or attach the LocalTalk connector to the printer port and plug the LocalTalk cable into the box.

You can easily recognize the printer port by its icon.

- *See also:*
- "Choosing a Printer" in Chapter 4
 - "Choosing a Network Printer" in Chapter 7

Connecting a modem

The *modem port* on the Macintosh back panel is a serial port that is almost identical to the printer port. You use it to connect an external *modem*, a device that converts the computer's signals for transmission over telephone lines.

This port is preferable for modem connection because the computer gives it priority over the printer port when checking for activity, which helps to assure that the modem's communications link will remain intact.

If necessary, you can connect a printer to the modem port or a modem to the printer port, however.

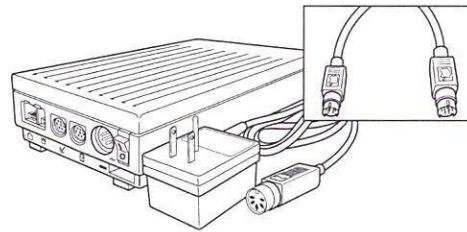

1 Assemble the components you need: modem, appropriate cable, and setup instructions.

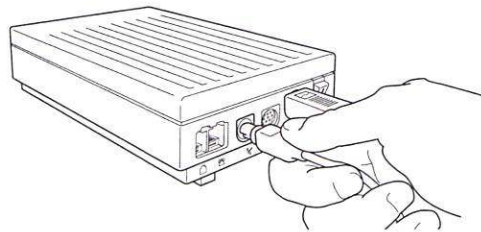

2 Attach the appropriate connector on the modem cable to the modem. (Consult the modem's setup instructions for details.)

Modem icon — 

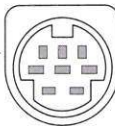
Modem port — 

3 Attach the small, round connector on the modem cable to the modem port on the back panel of your Macintosh.

You can easily recognize the modem port by its icon of a telephone handset.

Connecting an external floppy disk drive

Some Macintosh models have a *disk drive port*, to which you can attach a floppy disk drive.

You can also connect a non-SCSI hard disk such as the Apple HD 20 (no longer manufactured or supported with system software).

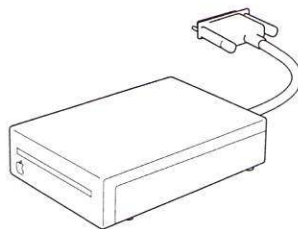

1 Make sure that your Macintosh has a disk drive port, then assemble the components you need: external drive, appropriate cable, and setup instructions.

Disk drive port icon — 

Disk drive port — 

2 Attach the free end of the disk drive cable to the disk drive port on the back panel of your Macintosh.

You can recognize the disk drive port by its icon of a disk.

Connecting Apple Desktop Bus devices

On most Macintosh models, you connect the mouse and the keyboard to Apple Desktop Bus™ (ADB) ports. These ports allow you to use a variety of input devices with your system, such as a graphics tablet, a specialized keyboard, a trackball, a light pen, or a barcode reader.

You can daisy-chain ADB devices and thereby connect several to each ADB port on the computer's back panel. Most Macintosh keyboards also contain an extra ADB port, and some monitors have an ADB port.

The number of input devices you can connect to the computer is limited by the combined power they require and by their performance. The practical limit of devices is probably six—three for each ADB port on the Macintosh. Performance of the devices is likely to be unacceptably slow with more devices than three per port.

- △ **Important:** Do not exceed the Apple Desktop Bus power requirements when using ADB input devices. The combined power used by all devices must not exceed 500 mA (milliamperes). Be sure to check the power required for each device you use and make certain that the total needed is less than 500 mA. Consult the *Special Options and Technical Information* for your Macintosh model for more information. △

Apple Desktop Bus device connected to a Macintosh

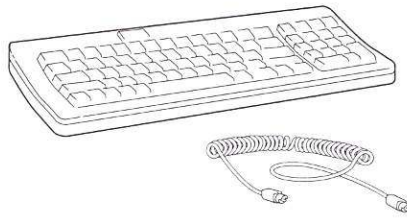

1 Confirm that the device meets ADB power requirements, then assemble the components you need: keyboard, mouse, or other device; ADB cable; and setup instructions.

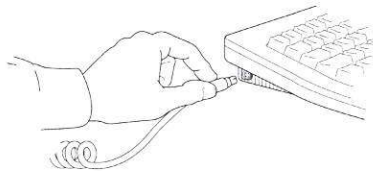

2 Attach one end of the ADB cable to the device, if necessary. (Consult the device's setup materials for any special instructions.)

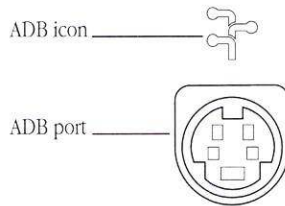

3 Attach the other end of the cable to the ADB port on the back panel of your Macintosh.

You can recognize the ADB port by its icon.

Apple Desktop Bus device daisy-chained to another ADB device

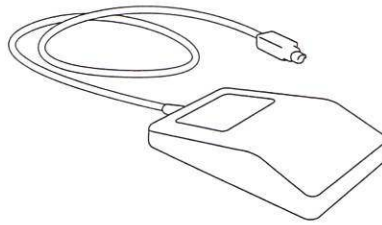

1 Confirm that the device meets ADB power requirements, then assemble the components you need: mouse, graphics tablet, or other device; ADB cable; and setup instructions.

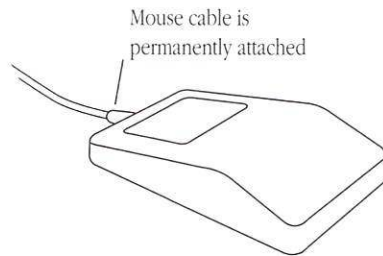

2 If necessary, attach one end of the cable to the ADB port on the device you are adding. (Consult the device's setup materials for any special instructions.)

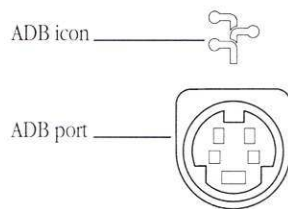

3 Attach the other end of the cable to the ADB port on the device at the end of the daisy chain.

You can recognize the ADB port by its icon. The icon may not be located directly above the socket as shown here.

- ❖ *Macintosh Plus mouse and keyboard:* The Macintosh Plus does not have ADB ports; its mouse connects to a mouse port on the back panel of the computer and its keyboard plugs into the front of the computer. ❖

Connecting audio devices

You can attach an audio device, such as an amplifier or headphones, to the audio jack on the back of the Macintosh. The audio jack accepts a standard stereo miniplug, like that used to attach headphones to a portable stereo player.

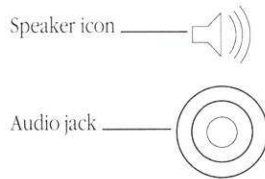

Connect the audio device to the audio jack on the back panel of the Macintosh, using a stereo miniplug.

You can recognize the audio jack by its icon of a speaker.

Adding an additional monitor

You can use two different monitors simultaneously with most Macintosh models.

On some modular Macintosh models, such as the Macintosh IICX, you connect the additional monitor to a video card installed in the computer. On other models, such as the Macintosh IIfx, you can connect the additional monitor to a video card or to the computer's built-in video port.

Connecting a monitor to a built-in video port

Some Macintosh models provide a built-in video port to which you can attach the first or second monitor for your system.

△ **Important:** If you're connecting a monitor to the built-in video port of your Macintosh, make certain that the computer is turned off before connecting the monitor. If it is turned on while the monitor is connected, no system RAM will be reserved for the built-in video. △

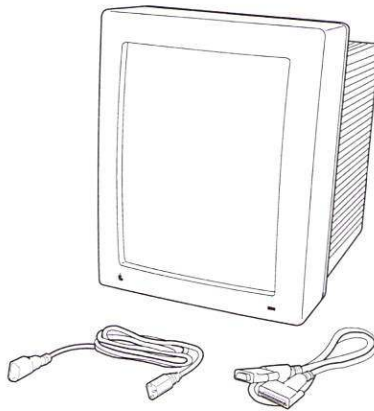

1 Assemble the components you need: monitor, appropriate cable, power cord, and setup instructions.

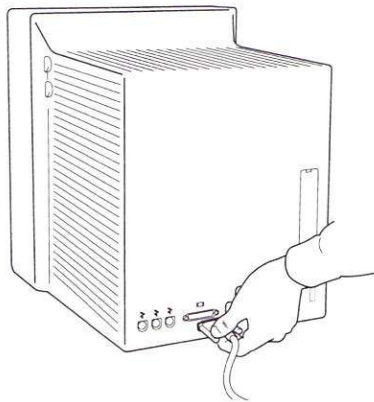

2 Attach one end of the monitor cable to the monitor. (Consult the monitor's setup materials for special instructions.)

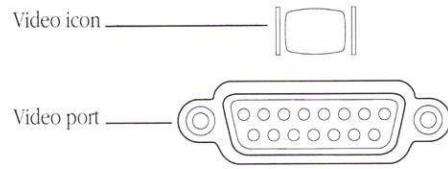

3 Attach the free end of the monitor cable to the video port on the back panel of your Macintosh.

You can recognize the video port by its icon.

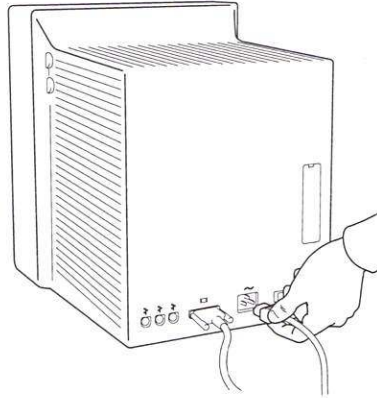

4 Attach the power cord to its socket on the monitor, then plug the other end into a grounded outlet.

You can plug one monitor into the back panel of the Macintosh; a second monitor must be plugged directly into an outlet.

Connecting a monitor to a video card

You can connect a monitor to a video card installed in the Macintosh. The card must be installed in the computer before you connect the monitor.

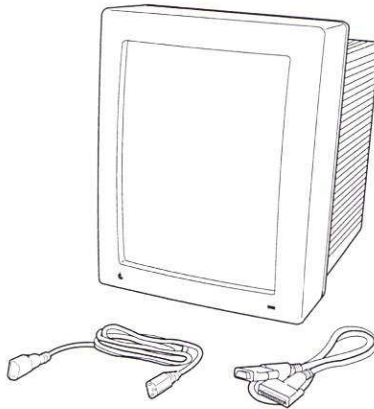

1 Assemble the components you need: monitor, appropriate cable, power cord, and setup instructions.

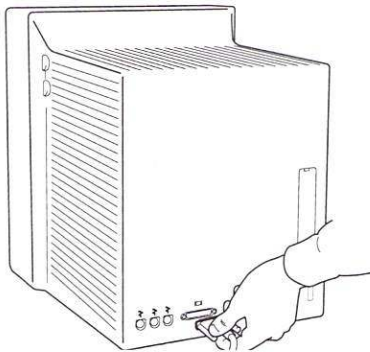

2 Attach one end of the monitor cable to the monitor. (Consult the monitor's setup materials for special instructions.)

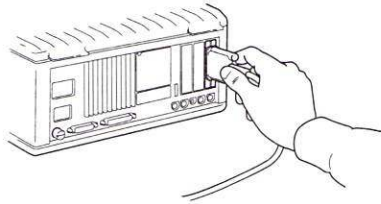

3 Attach the free end of the monitor cable to the port on the video card at the rear of your Macintosh.

Most video cards do not have an icon to identify the video port. Consult your dealer or Apple representative if you are unsure about the purpose of the port on a card in the computer.

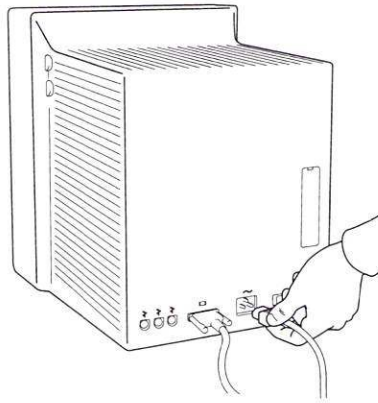

4 Attach the power cord to its socket on the monitor, then plug the other end into a grounded outlet.

You can plug one monitor into the back panel of the Macintosh; a second monitor must be plugged directly into an outlet.

- ❖ *Additional monitor for compact models:* On models that have a built-in monitor and can also use an external monitor, such as the Macintosh SE, the external monitor is connected to an adapter that must be installed by an authorized Apple representative. ❖

Positioning monitors When you're using two monitors, you may need to position them to avoid interference on the screen of one monitor caused by signals from the other.

▲ **Warning:** When setting up your monitors, be sure not to cover the ventilation openings on the monitors or on the Macintosh. Check the setup guide for your Macintosh model and the monitor's documentation for special instructions. ▲

➤ *See also:* • "Indicating the Relative Positions of Multiple Monitors" in Chapter 8

Installing expansion cards

Macintosh II family computers contain slots into which you can install expansion cards. The interface through which these cards exchange signals with the computer's microprocessor is the NuBus™ interface; consequently, the cards are known collectively as NuBus cards, and the expansion slots are called NuBus slots.

Most video cards used with monitors are NuBus cards; other NuBus expansion cards include memory cards, specialized graphics and video cards, coprocessor cards, and network interface cards.

The number of NuBus expansion slots varies among the Macintosh II models, though most have either three or six slots.

Figure 9-3 shows the expansion slots in some Macintosh II-family computers.

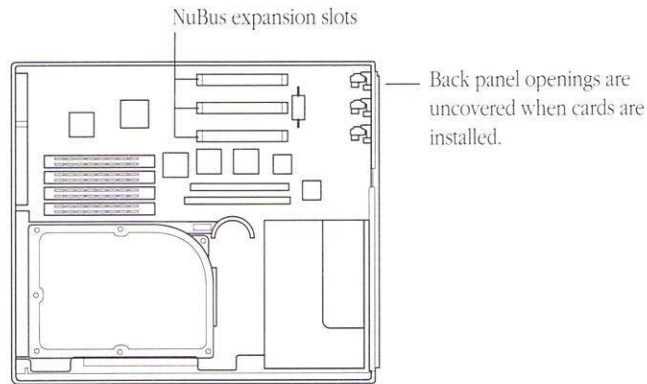
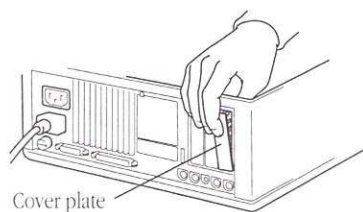

Figure 9-3 The three NuBus slots in a Macintosh IIci

△ **Important:** If you are installing fewer cards than the number of expansion slots in your Macintosh, position the cards for maximum airflow and cooling: leave an empty slot between cards, and use the slot closest to the fan last. △

The instructions that follow summarize installation of a NuBus expansion card. See the guide *Setting Up Your Macintosh* for your Macintosh model for more detailed instructions. The illustrations in this summary show the Macintosh IICX.



1 Take the lid off your Macintosh and remove the plastic cover plate from the end of the slot into which you will install a NuBus card.

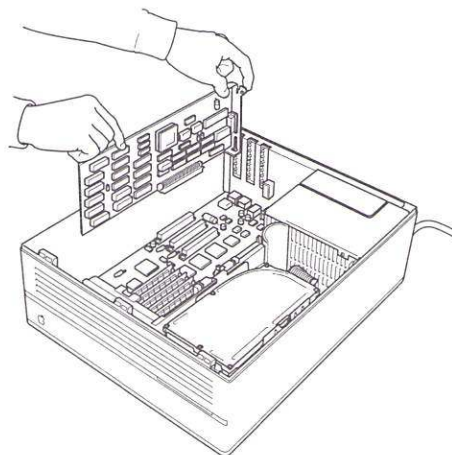

2 Gently slide the NuBus card, with the gold-tipped connector pointing downward, into the slot.

Hold the card carefully at the outside top edges. Press the card down to be sure that it's seated in the slot.

As you position the card, take care to fit the connector on the end of the card into the slot on the computer's back panel.

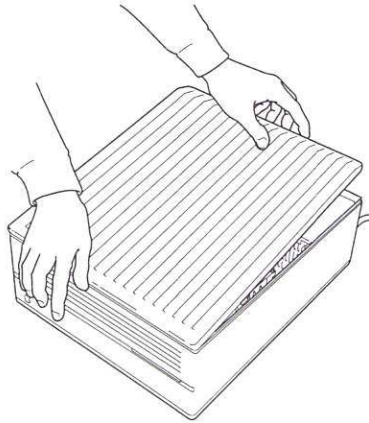

3 Replace the lid on the computer.

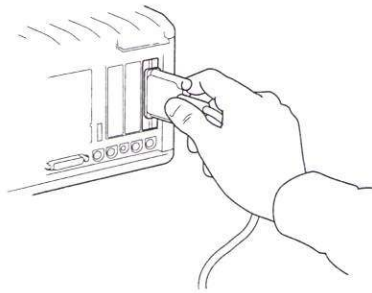

4 Attach the appropriate cable or cables to the connector on the NuBus card.

Consult the documentation for the card and the device to be connected to it for detailed instructions.

Using multiple expansion cards

If you use two or more NuBus expansion cards in your Macintosh, you must observe the following precautions to assure safe operation of the computer.

Power requirements and limitations

The combined power consumption of all NuBus cards in your Macintosh must not exceed the limits established for that model.

Expansion cards can draw three types of power from a NuBus slot:

- +5 volt current
- +12 volt current
- -12 volt current

Each card may draw from these currents in varying amounts. Consult the *Special Options and Technical Information* booklet for your Macintosh model and the specifications for each card that you use to determine the combined power consumption for each type of current. Then make certain that the totals do not exceed the recommended limits. (You can calculate the total limits by multiplying the recommended limit per card by the number of slots in your model.)

Type of current	Recommended limit per card
+5 volt	2.0 amps
+12 volt	0.175 amps
-12 volt	0.100 amps

- ▲ **Warning:** Exceeding the power limits could damage one or more NuBus cards or the computer. ▲

Assuring adequate ventilation

When operating, NuBus cards generate heat. If you use several cards in your Macintosh, make certain that you position them to allow maximum air circulation around the cards.

For example, if your Macintosh has six NuBus slots and you are using three cards, place the cards in the second, fourth, and sixth slots (counting from the end opposite the disk drive) to assure the maximum amount of air circulation.

Installing cards in a special slot

Some Macintosh models can use a type of expansion card that does not use the NuBus interface. This card fits into a special slot, called the memory cache slot in some models and the processor-direct slot in other models.

- △ **Important:** If you plan to use a card in a special slot, make certain that the card you install is designed for your Macintosh model. Installing a card designed for this slot in a different model could damage the card and the computer. △

Instructions for installing a card in the memory cache slot or the processor-direct slot vary among the models that use these cards. Consult *Setting Up Your Macintosh* and *Special Options and Technical Information* for your Macintosh model for details.

Expanding memory on the main circuit board

The RAM in most Macintosh models is provided in packages called *Single In-line Memory Modules*, or *SIMMs*. Each SIMM consists of a group of RAM chips on a circuit board that has electrical contacts along one edge. This board is plugged into a SIMM socket on the computer's main circuit board.

The RAM in your Macintosh can be expanded by adding to the SIMM modules already installed or exchanging the modules for ones that contain chips with greater storage capacity. (The system RAM can also be expanded by installing a NuBus memory card.)

If you plan to expand the computer's memory, make certain that the chips or SIMMs used are the correct ones for your Macintosh model. Consult the *Special Options and Technical Information* booklet for your Macintosh model for information about the RAM chips and SIMMs.

- ▲ **Warning:** RAM expansion on the main circuit board should only be done by an authorized Apple representative or another qualified technician. Modification or expansion by anyone except qualified personnel voids the equipment's warranty and could cause damage. ▲

10



Macintosh Maintenance and Troubleshooting

Your Macintosh computer is sturdy and requires little maintenance. But like any piece of electrical equipment, it should be handled carefully and positioned in accordance with its design and specifications.

This chapter provides some general precautions for setting up and working with the computer, as well as guidelines for maintaining a safe operating environment for the Macintosh, instructions for cleaning system components, and a note about Apple service and support.

Safety and general care

Follow the suggestions in this section to ensure that your Macintosh stays in good operating condition.

All system components

When setting up and using the computer and its components, be sure to

- Handle all equipment with care and always place components on a sturdy, flat surface.
- Follow the setup instructions provided with your Macintosh and its components precisely.
- Always hold a cable by the connector at one end when attaching it to or removing it from a component; don't force a connector into a socket or plug on the Macintosh or a component. If you can't get the pieces to join easily, consult your Apple dealer or a technician for help.
- Turn off the computer and all components before adding or removing any part of the system. If you add or remove a component or its cable while the computer is on, you may damage the Macintosh, the component, or both.
- Keep food and liquids away from the immediate area of your Macintosh if possible, and be extremely careful not to spill any liquid on the computer, keyboard, mouse, or other components.
- If you do spill food or liquid into the computer, be sure to turn it off and unplug it before attempting to deal with the situation.

▲ **Warning:** Plug the power cords for the computer and its components only into three-prong, grounded outlets. The Macintosh's grounding-type plug is a safety feature; do not defeat the purpose of this plug. Disconnect the power plug if it becomes frayed or otherwise damaged. ▲

- ▲ **Warning:** Your power supply is a high-voltage component and should not be opened for any reason. There are no serviceable parts inside. If you think that your power supply needs servicing, please contact your authorized Apple service provider. ▲

Monitor Whether your Macintosh has a built-in screen or a separate monitor, be sure to

- Turn down the brightness control on the screen if you leave the computer turned on for extended periods; if the brightness is not turned down, the image on the screen could “burn in” and permanently damage the screen. (If your Macintosh model does not have a brightness control, it has a special section of the Control Panel that lets you adjust screen brightness. For instructions on using the Brightness Control Panel, see *Special Options and Technical Information*.)

You can use a “screen-saver” program to remove or vary the image on the monitor’s screen when the computer is turned on but idle for a specified period of time. These programs are available from independent suppliers or user groups.

- If your Macintosh has a separate monitor, position the monitor so that none of its ventilation openings are covered or obstructed.
- Follow positioning instructions for a monitor precisely— don’t put it on any surface not strong enough to support it. Some large monitors, such as the Apple Two-Page Monochrome Monitor, cannot safely be placed on top of the main unit of a modular Macintosh.

Keyboard

Take special care not to spill any liquid on the keyboard or to get greasy or sticky substances on it. If you should spill a liquid on the keyboard and it stops working, follow these procedures:

- If the liquid is thin and clear, try unplugging the keyboard, turning it upside down to let the liquid drain out, and drying it for 24 hours at room temperature. If the keyboard still doesn't work, take it to your authorized Apple dealer for repair.
- If the liquid is sweet or sticky, unplug the keyboard and take it to your authorized Apple dealer for repair.

Floppy disk drives

Whenever you transport the Macintosh or an external floppy disk drive, be sure to

- Place the plastic disk-shaped piece (placed in the drive at the factory) in the internal floppy disk drive and in any external drives when you move them. If your Macintosh model has a SuperDrive, you don't need to use a plastic disk—SuperDrives can be moved without the protector.

Floppy disks

Figure 10-1 summarizes the correct and incorrect ways to handle floppy disks.

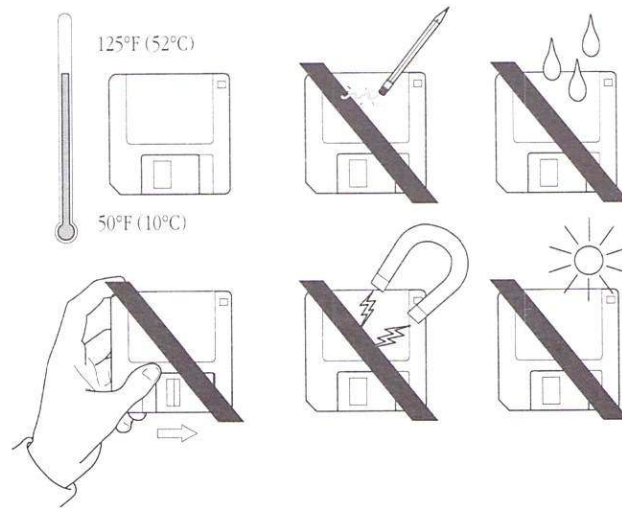

Figure 10-1 Dos and don'ts of handling floppy disks

Operating environment

The Macintosh is designed to operate reliably in a suitable environment. To maintain this environment:

- Keep the Macintosh and components out of direct sunlight and free from exposure to rain or other moisture.
- Operate the Macintosh only at temperatures between 50 degrees and either 95 or 104 degrees Fahrenheit (10 degrees and either 35 degrees or 40 degrees Centigrade), depending on the model, and at a humidity ranging from 5 percent to 95 percent. (See the *Special Options and Technical Information* booklet for your model for details.)
- Be certain that all components are positioned so that none of their ventilation areas are blocked or partially blocked. Do not put papers, disks, or other items over the air circulation areas of the system, even temporarily. Preventing proper air circulation could result in overheating of a component and possible damage or unreliable operation.
- If your Macintosh and components are positioned so that you see interference on the monitor's screen or see or hear interference on a nearby television or radio, move the affected components farther apart.

Cleaning system components

Computer and peripheral-device cases

You can clean the exterior of most Macintosh system components, the monitor's screen, and the mouse's mechanical parts.

To clean the case of your Macintosh or a peripheral device:

- Use a damp, soft, lint-free cloth to clean the computer's exterior. Avoid getting moisture in any openings.
- Don't use aerosol sprays, solvents, or abrasives when cleaning the computer or other components.

Monitor

Follow this guideline when cleaning the monitor's screen:

- Put household glass cleaner on a soft cloth and wipe the screen. Don't spray the cleaner directly on the screen, because the liquid may drip into the monitor's or computer's interior.

Mouse

The mouse contains a small ball that rolls as you move the device. You can keep this ball free of dirt and grease by using the mouse on a clean, hard surface and cleaning it occasionally.

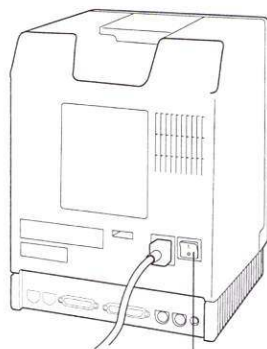

Power switch

1 To clean the mouse, first turn off the Macintosh.

You should always turn off electrical equipment before disassembling any part.

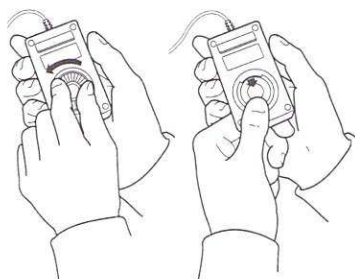

2 Turn the mouse over and open the plastic ring on the bottom that holds the ball.

Macintosh models use two different types of rings on the mouse; one is opened by turning the ring counter-clockwise, the other is opened by pulling the ring straight down until it snaps.



3 Remove the ring and the ball beneath it.

You may be able to lift off the ring while holding the mouse upside down; if not, turn the mouse over while holding one hand underneath it to catch the ring and ball.



4 Clean the three small rollers inside the mouse with a cotton swab moistened with alcohol.

Rotate the rollers to clean all their surfaces.

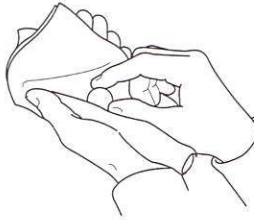

5 Wipe the mouse ball with a clean, soft, dry cloth.

Don't use any liquid to clean the ball.

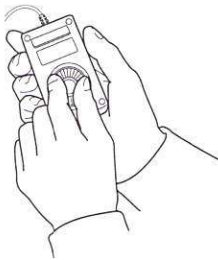

6 Gently blow into the mouse case to remove any dust that has collected there, then replace the ball and ring.

Testing and repairing a disk

Both floppy disks and hard disks can become damaged from repeated use and handling. The Macintosh system software provides some tools for testing disks and repairing some types of damage or wear.

If you see a message reporting that a disk is damaged or unreadable, these tools may help to diagnose and correct the problem.

Using Disk First Aid to test or repair a floppy disk or a hard disk

You can test and repair either type of disk with the Disk First Aid™ application, supplied with system software.



1 To test or repair a disk, start Disk First Aid by double-clicking its icon.

The application opens and presents a dialog box for you to select a disk.

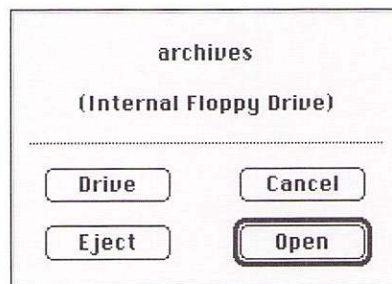

2 Select the disk you want to test and repair, using the Drive and Eject buttons as necessary. Then click Open.

The disk you selected is the volume listed, and a message reports that Disk First Aid is ready.

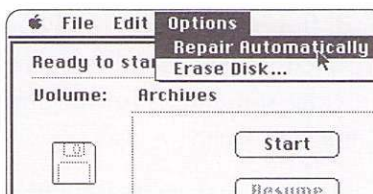

3 If you want automatic repair, choose Repair Automatically from the Options menu.

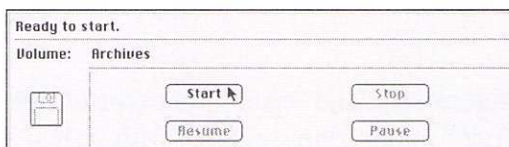

4 Click Start to begin testing the disk.

A message at the top of the screen reports testing and repair progress and results.

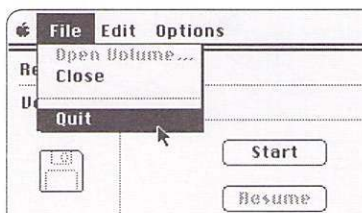

5 When testing and repair are completed, choose Quit from the File menu.

Alternatively, to test another disk, choose Close from the File menu, then select and open the disk and follow steps 3 and 4 above.

Using HD SC Setup
to test a SCSI hard disk

You can test a SCSI hard disk with the HD SC Setup application, supplied with the system software.



1 Start HD SC Setup by double-clicking its icon.

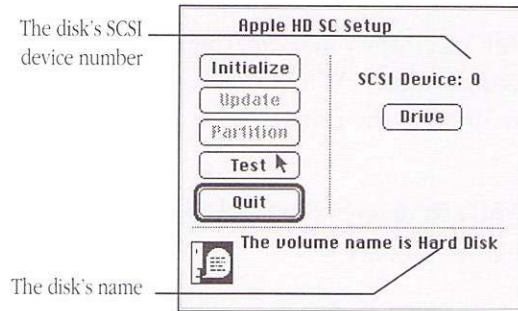

2 Select the disk you want to test, using the Drive button if necessary. Then click Test.

The disk's SCSI device number is displayed above the Drive button; the disk name is displayed in the message box at the bottom of the screen.

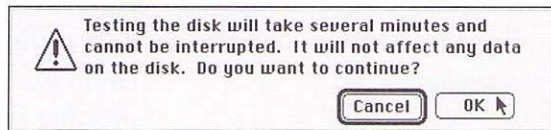

3 An alert box appears before testing begins, asking you to confirm or cancel the test. Click OK to continue.

Testing begins; the spinning beach ball icon indicates that testing is under way.



4 When a dialog box appears telling you that testing is complete, click **Quit**.

Changing the clock battery

All Macintosh models have a system clock that runs continuously. When the computer is turned off, a battery maintains the time.

Macintosh Plus

You can change the clock battery in the Macintosh Plus and earlier models.

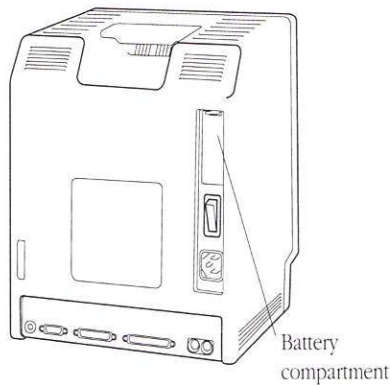

1 To change the clock battery, first locate the battery compartment on the back right side of the computer and open it by pressing the latch.

Remove the cover of the battery compartment.

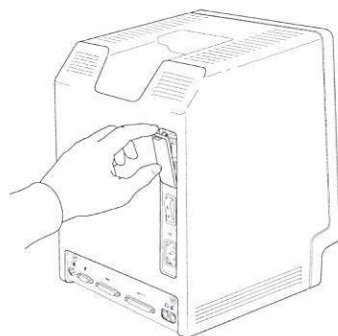

2 Remove the battery from the compartment and replace it with another battery of the same type, in the same position.

The battery you need is a 4.5-volt unit—the Eveready 523 or its equivalent.

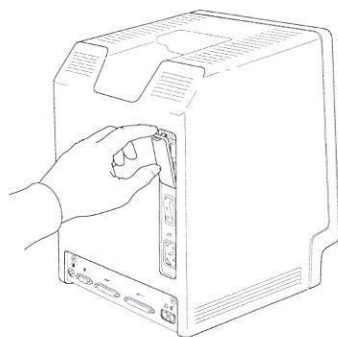

3 Replace the cover on the battery compartment.

Other Macintosh models

The clock battery on all other Macintosh models is located inside the computer's case. If your system clock begins to keep inaccurate time or stops when the computer is turned off, have your authorized Apple dealer or representative replace the battery.

Troubleshooting

At some time you may experience a problem with your Macintosh. The descriptions of problems and possible solutions that follow should help you in troubleshooting difficulties with your Macintosh's operation.

Be sure to check the *Special Options and Technical Information* booklet for your model for any additional troubleshooting information. If you have a Macintosh Portable, consult both the *Special Options and Technical Information* and the *Macintosh Portable Handbook*.

Avoiding data loss or damage

In recent years, many computer users have experienced problems with viruses—malicious programs that damage files or erase disks. A virus could be introduced into your Macintosh system from a disk you or someone else puts in its drive, from a network device such as a file server, or from an electronic bulletin board service.

Check regularly for viruses

You can use any of several virus-detection and elimination programs to check your Macintosh disks for viruses. Such programs are available from user groups, computer bulletin boards, and dealers.

Even if you don't notice problems with your computer's operation or the information on your disks, you should check for viruses frequently if you exchange disks or information with other users.

A good virus strategy includes these elements:

- Check your primary disk or disks regularly with a virus-detection program and correct any problems it finds.
- Whenever you get a disk from anyone—even commercial software—check it for viruses before using it or copying anything from it to your system.
- If your Macintosh is on a network or you use a modem to connect with information services or bulletin boards, check for viruses as often as it's practical—ideally after each time you copy any information from an outside source.
- If you are part of a work group that includes a number of Macintosh users, set up a “virus-detection station” that everyone can use to check disks (and to copy the latest version of virus-detection software if your group has a site license for it).
- If you give information to other Macintosh users on disk or send information electronically, make certain that there are no viruses on your system before distributing the information.

Computer operation

Here are some potential problems, likely causes, and suggested solutions.

The computer is turned on but the screen is dark

Cause: The Macintosh is not getting power, or the screen isn't getting light.

Try these actions:

- Check that the power cord is plugged in and firmly connected to the computer and that the electrical socket has power.
- Check the screen's brightness control and turn it up if necessary.
- If you use a screen-saving program, press a key or move the mouse to activate the screen's image.

When you start up, the screen is bright but the desktop doesn't appear

Cause: The system software is not on the disk or the disk drive is not operating properly.

When you turn on the Macintosh and insert a disk (if your system doesn't have an internal hard disk), you should see one of the icons shown in Figure 10-2. (If you turn on the Macintosh and don't insert a disk, you'll see the disk icon with the blinking question mark.)

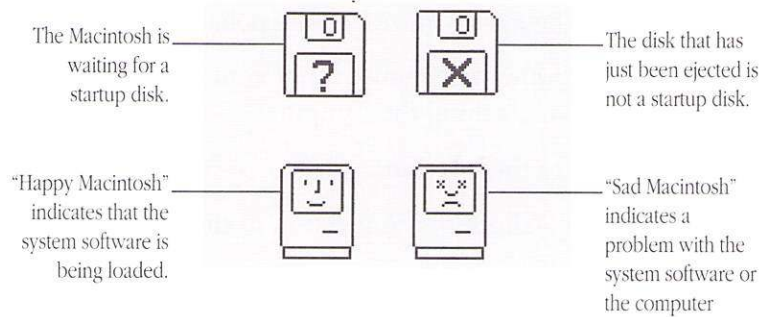

Figure 10-2 Icons the Macintosh might display at startup

Try these actions:

- If you see the “happy Macintosh” icon, you don’t need to do anything. The system software is being loaded.
- If you see a disk icon with a blinking question mark on it, your system is waiting for you to insert a startup disk. If your Macintosh has an internal hard disk, this icon means that the computer doesn’t recognize that disk.

If this happens, use a startup disk to start up and check to see if the hard disk icon appears on the desktop. (If not, see your dealer.)

- If you see the disk icon with an X on it, you need to insert a startup disk—one that contains an installed System Folder.
- If you see the “sad Macintosh” icon, there’s a problem with the system software on the disk or possibly with the computer.

Eject the disk (by turning off the computer, then holding down the mouse button while you turn the computer on again). Try starting up with a different startup disk. If the “sad Macintosh” icon appears again, see your dealer.

The mouse moves but the pointer doesn't move

Cause: The mouse is not connected properly or its signals are not reaching the computer.

Try these actions:

- Check the connection of the mouse cable.
- See whether the mouse needs cleaning, and if so, clean it. (See the instructions in this chapter.)
- Restart the Macintosh with a different startup disk. If the pointer still doesn't move, consult your dealer.

Typing on the keyboard produces nothing on the screen

Cause: The keyboard is not connected properly or its signals are not reaching the computer.

Try these actions:

- Check the connection of the keyboard cable at both ends.
- If the connections are secure and typing still yields no results, shut down and turn off the Macintosh, then unplug the keyboard cable. Place the computer end of the cable in the other Apple Desktop Bus port on the computer and the keyboard end in the other ADB port on the keyboard. (You may have to unplug the mouse to do this.) If typing still shows nothing on the screen, the problem is most likely in the keyboard itself.
- Restart the Macintosh with a different startup disk. If typing still doesn't produce text on the screen, consult your dealer.

You can't save anything onto a floppy

Cause: The disk can't accept information, it is damaged or locked, or the disk drive is not working properly.

Try these actions:

- If you see a message reporting that the disk is not initialized, and you know that it has been initialized, eject the disk and carefully insert it again. If the same message appears, the disk is probably damaged. (You may be able to recover the information on it with a disk-recovery program.)
- If you see a message that the disk is full, eject that disk and insert another that has adequate space for your document, or erase some unneeded data from the disk. If you see this message while working in a program, you can eject the disk by choosing the Save As command from the File menu and using the buttons in the directory dialog box.
- Check the disk for obvious damage to the plastic case or the sliding metal shutter.
- Make sure the locking tab on the back of the disk at the top left is in the down (unlocked) position. See Chapter 6 for more information.
- Insert a different disk and try saving again. If you can't save on the second disk, the problem may be with the disk drive.
- Before concluding that the disk drive is the problem, save your files onto a disk in a different drive, if you have one, and then restart the Macintosh. Try saving something on a disk you know is not damaged placed in the suspect drive. See your dealer if saving fails again.

You can't eject a floppy disk

Cause: The signal to eject the disk is not reaching the computer or the disk or drive is damaged.

Try these actions, in the order presented here:

- Hold down the Command and Shift keys and press the number 1 key in the top row of the keyboard to eject a disk in the internal drive; press Command-Shift and the number 2 to eject a disk in an external floppy drive or the second internal drive.
- If the preceding action doesn't work, turn off the Macintosh, then hold down the mouse button when you turn it on again.
- If neither of the preceding actions works, locate the small hole to the right of the disk drive's opening, and carefully insert the end of a straightened paper clip into it. Press gently until the disk is ejected, but *do not force it*. (See Figure 10-3.) This method of ejecting a disk should be used only when the other suggested methods do not work. If this method doesn't work, take the computer or disk drive to your dealer to have the disk removed.

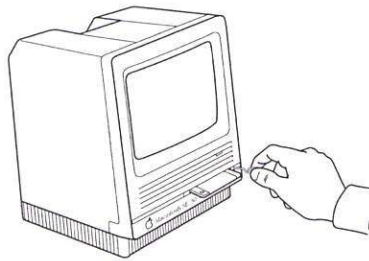

Figure 10-3 Ejecting a disk with a straightened paper clip—a last resort

You can't start up from a hard disk or see its icon

Cause: The computer did not recognize the disk's signals or the disk drive is not working properly.

Try these actions:

- If the hard disk drive is an external one, make sure it is turned on and its cable is connected firmly, then restart the Macintosh.
- If the disk drive is an internal one, turn off the Macintosh, wait at least 10 seconds, then turn it on again.
- If the hard disk is your startup disk, start up with a different disk and reinstall the system software on the hard disk.
- If the hard disk is not your startup disk and you have more than one hard disk in your Macintosh system, check the SCSI ID number of each external hard disk and all other SCSI devices connected to your computer. If two devices have the same ID number, one of the devices will not be recognized by the computer. Change the duplicate number to a number not currently used. See Chapter 9 for more information.

➤ *See also:* • “Testing and Repairing a Disk” in this chapter

A dialog box with a bomb appears

Cause: Your system has a software problem.

Try these actions:

- Click the Restart button on the screen (if one is displayed as part of the message). The computer may start up normally.
- If no Restart button is displayed (or clicking it doesn't work), use the power switch to turn off the Macintosh, wait at least 10 seconds, then turn it on again. The system may start up normally.

- If the Macintosh doesn't restart with the same startup disk, try to start up with a different startup disk.
- If the Macintosh starts up with a different disk, check the startup disk and program you were using when the bomb message appeared. You may have been using elements of the system software that were incompatible with each other or with the program you were using. For example, if you used the newest version of the System and Finder with an old version of the Font/DA Mover, you could get the bomb message. Reinstalling the system software may correct the problem with the first startup disk.
- Sometimes incompatible desk accessories can cause the system to display a bomb message. Try removing any recently installed desk accessories to see if the computer works all right.
- Occasionally it's necessary to pull the plug, if the power switch doesn't succeed in cutting power to the computer.

△ **Important:** Always be sure to upgrade all parts of your system software when you install a new version of the Macintosh system software, and always verify that the programs you use are compatible with the version of system software you have installed. △

The pointer suddenly “freezes” on the screen

Cause: Your system has a software problem.

Try these actions:

- Turn off the Macintosh with the power switch on the back, wait at least 10 seconds, then turn it on again. The system may start up normally.
- If the Macintosh doesn't restart with the same system disk, try to start up with a different startup disk.
- If the Macintosh starts up with a different disk, check the startup disk and program you were using when the system froze. You may have been using elements of the system software that were incompatible with each other or with the program you were using. Reinstalling the system software may correct the problem with the first disk.
- Occasionally the system may freeze when you are using MultiFinder. With the same combination of programs open, check the allocation of system memory in the About the Finder window. See “Managing System Memory” in Chapter 3 for more information.

Δ **Important:** Always be sure to upgrade all parts of your system software when you install a new version of the Macintosh system software, and always verify that the programs you use are compatible with the version of system software you have installed. Δ

Printer operation

If you have a printer connected to your Macintosh, you might encounter one of the following situations.

You give the command to print a document and the printer doesn't respond

Cause: The command isn't reaching the printer or the printer isn't working properly.

Try these actions:

- Check that the printer is turned on and warmed up (if it's a LaserWriter, it should have printed the sample page).
- Check the cable connections to the printer.
- If your printer is an ImageWriter, make sure that the Select light is on. (Press the Select button to turn the light on.)
- Check that the printer is selected in the Chooser. See "Choosing a Printer" in Chapter 4.
- If the Chooser does not show an icon for the type of printer you want to use, place the driver or drivers for that printer in the System Folder of your startup disk and restart the Macintosh. See Chapter 4 for more information.

You print a document on a network printer and it causes the printer to restart or to display an error message.

Cause: The printer has received conflicting signals.

Try these actions:

- Make sure that you are using the same version of the printer driver as all other people on your network. (If not, place that driver in your System Folder and restart the Macintosh.)
- If you see an error message stating that the printer could not print your document, turn off the printer for at least 10 seconds, then turn it on again and wait for the printer to warm up before trying to print again.

General tips If your Macintosh or a component is not working properly but its problem is not described in this chapter, you can try some general measures that may solve the problem.

Start over

Often you can eliminate a problem simply by clearing the computer's memory and starting over.

- If possible, save any open documents in which you've made new changes before restarting the Macintosh. (If your system is frozen or you have a bomb message on the screen, saving won't be possible.)
- Choose Restart from the Special menu, if possible, or turn off the Macintosh, wait at least 10 seconds, then turn it on again.
- If your problem is with a peripheral device, such as a printer or external hard disk, turn it off for 10 seconds or more, then turn it on again and restart the Macintosh.

Make certain that all parts of the system software are from the same version

These tips help keep your system software in good working order:

- When you install a new version of system software, be sure to copy it on all startup disks that you use, to avoid inadvertently working with two different system versions later.
- If the System Folder becomes damaged on one of your startup disks, either reinstall the software on that disk or copy the System Folder from a good disk onto the disk with the damaged folder.
- When you install a new version of system software, verify that the new versions of drivers for the printer and other types of devices you use are in the System Folder of your startup disks.

Make certain that your programs are in good working order

Here are tips for keeping your application programs working effectively:

- If you have problems with an application program, make another working copy of that program from the original program disk.
- If a new copy of the application program doesn't correct the problems with it, check with the program's manufacturer to make sure that the version of the program you have is compatible with the version of the Macintosh system software you are using. (You can often upgrade to a newer version of the program for a modest fee.)

- If you use a hard disk, be sure to keep only one System Folder and only one version of each application program on your disk.
- If you use any special programs that customize your System file (these programs are usually called *INITs*, *Control Panel devices*, or *CDEVs*), always check with the sources or developers of those programs before you install them to make sure that they are compatible with the version of Macintosh system software you're using.

Create free space on the startup disk

Occasionally you may see an error message reporting that the Macintosh doesn't have enough memory to start up.

Try these actions:

- Start up with another disk, then open the startup disk that didn't work and remove some items from it.
- If your Macintosh starts up from a hard disk, you can use a program that reduces the fragmentation of data on the disk. This procedure makes disk operation faster and creates larger areas of free space for startup. (You can obtain a utility program to reduce fragmentation from your Apple dealer.)

Take your time

When you see an error message on the screen, you don't have to take an action immediately. The message will stay on the screen until you click the button that's part of it or turn off the Macintosh.

To help you diagnose and correct the problem, try to gather as much information about the situation as you can before starting over:

- Make a note of exactly what you were doing when the problem occurred. Write down the message on the screen and its ID number. (This information will help a service person diagnose the problem should you need to take the computer to your authorized Apple dealer for repair.)
- Check the screen for any clues that are visible—a menu title selected, the program and document icons that are open, and anything else that seems relevant to the current situation.
- If you were writing new text, and were not able to save it before the problem occurred, you can write down the parts of the text still visible on the screen so that some of your work will be easy to replace.
- Ask other experienced Macintosh users about the problem you're having; they may have a solution for it.

Rebuild your desktop once a year

A process known as “rebuilding the desktop” helps your Macintosh keep track of data on your startup disks.

- To rebuild the desktop of a startup disk, hold down the Option and Command keys while starting up your computer.
- Follow the rebuilding procedure for each of your startup disks once a year.

Back up your work and your programs frequently

To ensure that the information and the programs you use with your Macintosh will always be available, back up your work regularly and back up each program when you begin using it.

- If you use a hard disk for most of your work, be sure to make copies of all key programs and files on floppy disks.
- To protect essential information, such as business archives and financial records, consider making duplicate backup copies on floppy disks and storing them in a location different from your regular Macintosh work place.

Service and support

To help you get the best performance from you Macintosh, Apple Computer, Inc. has established a worldwide network of full-support authorized Apple dealers. If you need answers to technical questions or information about product updates, your authorized Apple dealer can help you. Apple's Technical Support organization backs each dealer and international technical support group via AppleLink™, a state-of-the-art on-line electronic information service, to ensure prompt, reliable assistance.

Your dealer has the latest information on new hardware and software products as well as product updates. If you wish to upgrade your system, your dealer can help you select compatible components.

If your Macintosh or a peripheral device requires service, your local authorized Apple dealer is trained and ready to support you. Apple provides factory-quality parts and the latest available diagnostic equipment to the more than three thousand authorized Apple service centers throughout the world. Apple guarantees parts and warranty labor. (Regulations in each country determine the length of warranty. Some restrictions may apply, depending on the country of original purchase.)

If for some reason you cannot return to the authorized dealer from whom you purchased your system, go to the nearest service location. For the location nearest you, in the United States call (800) 538-9696; in Canada, call (800) 268-7796 or (800) 268-7637. For locations in other countries, either call the Apple headquarters in your country or write to

Apple Computer, Inc.	or	Apple Canada, Inc.
Customer Relations		7495 Birchmount Road
20525 Mariani Avenue		Markham, Ontario
Cupertino, CA 95014		L3R 5G2
USA		Canada

Apple also offers service options designed to meet your needs. One of these is the AppleCare™ Service Agreement (available in the United States, Canada, and Australia only), which extends full warranty coverage up to three years. Your AppleCare contract will be honored at any participating authorized Apple dealer within the country of purchase—an added benefit if you relocate. Local service means time saved in getting your Apple system back to work.

You can purchase AppleCare at any time, but it's a good idea to purchase it with your system, or at least before your warranty has expired, to avoid an owner-paid inspection.

There are also self-service plans designed to allow large installations to repair their own equipment. Whether you use your computer at home, in the office, or at school, Apple has a low-cost service plan for you. For details, please see your authorized Apple dealer.

Appendixes



Keyboards and Character Sets

Along with the mouse, you use the keyboard to communicate with your Macintosh. You can choose from several keyboards for use with most Macintosh models; the layout and selection of keys varies somewhat among the different keyboards.

No matter which keyboard you use with your Macintosh, you can use certain keys, such as Option, Command, and Shift, to type optional characters. The Key Caps desk accessory shows the location of optional characters for each font installed in the System file.

Keyboard layouts

The illustrations that follow show the layouts of the keyboards that can be used for various Macintosh models.

- *See also:*
- “Using Special Keys and Indicators on the Keyboard” in Chapter 1
 - Appendix B, “MacroMaker Command Files”
 - Appendix D, “Special Aids for Using the Mouse, Keyboard, and Screen”

Macintosh Classic/ Macintosh LC Keyboard

Power On key: On some Macintosh models, you press this key to switch on your computer. On the Macintosh Classic, this key has no function.

Tab key: Moves the insertion point horizontally to the next stopping place (such as a tab stop or data field in a dialog box or program).

Caps Lock key: A locking Shift key for letters only (numbers and symbols aren't affected).

Shift key: Produces uppercase letters (for the upper character on the key).

Control key: Like the Command key, works in combination with other keys to provide shortcuts or modify other operations.

Option key: Produces an optional set of special characters when pressed in combination with other keys.

Command key: Works with other keys as a shortcut to choosing a menu command or (in some programs) canceling an operation in progress, such as printing.

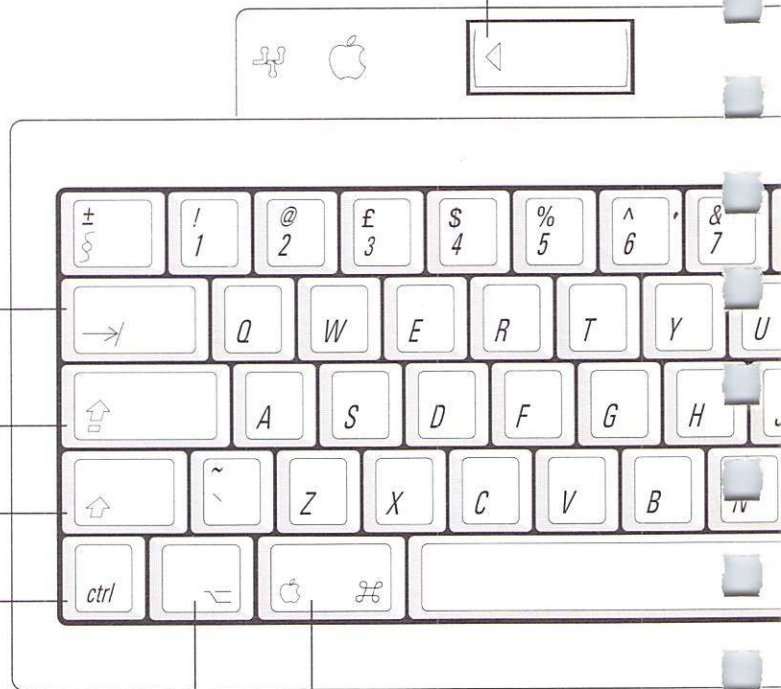

Delete key: Deletes any text currently selected, or whatever character is to the left of the insertion point.

Return key: Ends the current paragraph and moves the insertion point to the beginning of the next line. In a dialog box, pressing Return is the same as clicking the outlined button.

Numeric keys: These keys produce numbers and mathematical symbols.

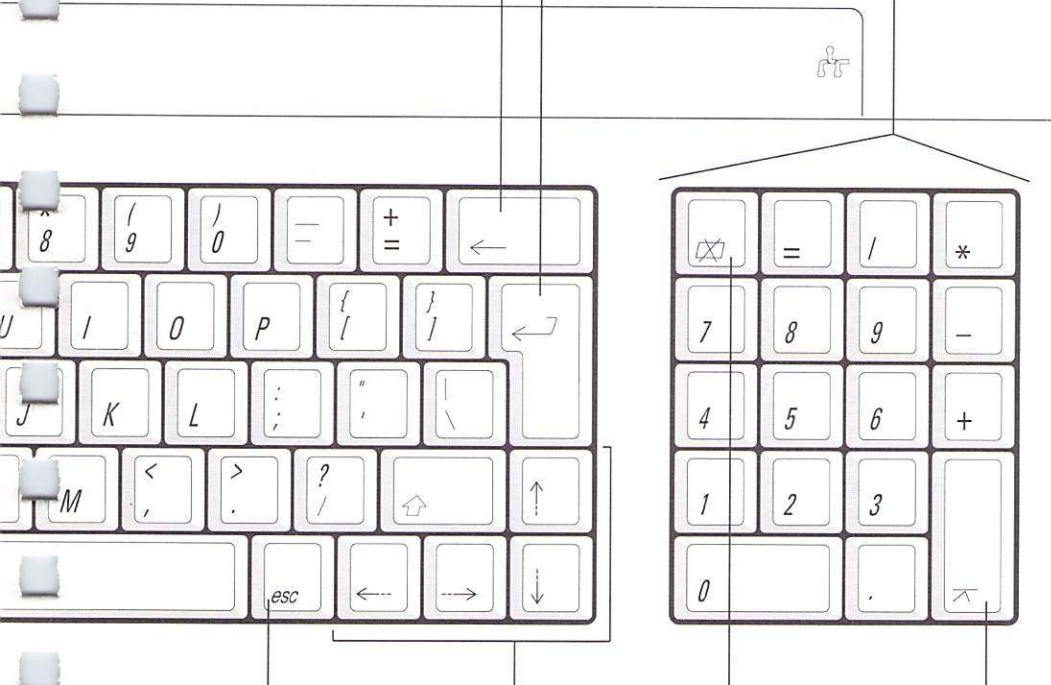

Esc key: Esc stands for *Escape*; the function of this key depends on the program you're using.

Arrow keys: Move the insertion point, as an alternative to using the mouse.

Clear key: Deletes the current selection, just as the Delete key does. In some programs, Clear may have other functions.

Enter key: In a dialog box, pressing Enter is the same as clicking the outlined button (or pressing Return); some programs require that you use Enter (not Return) to put data into specific fields.

Apple Keyboard

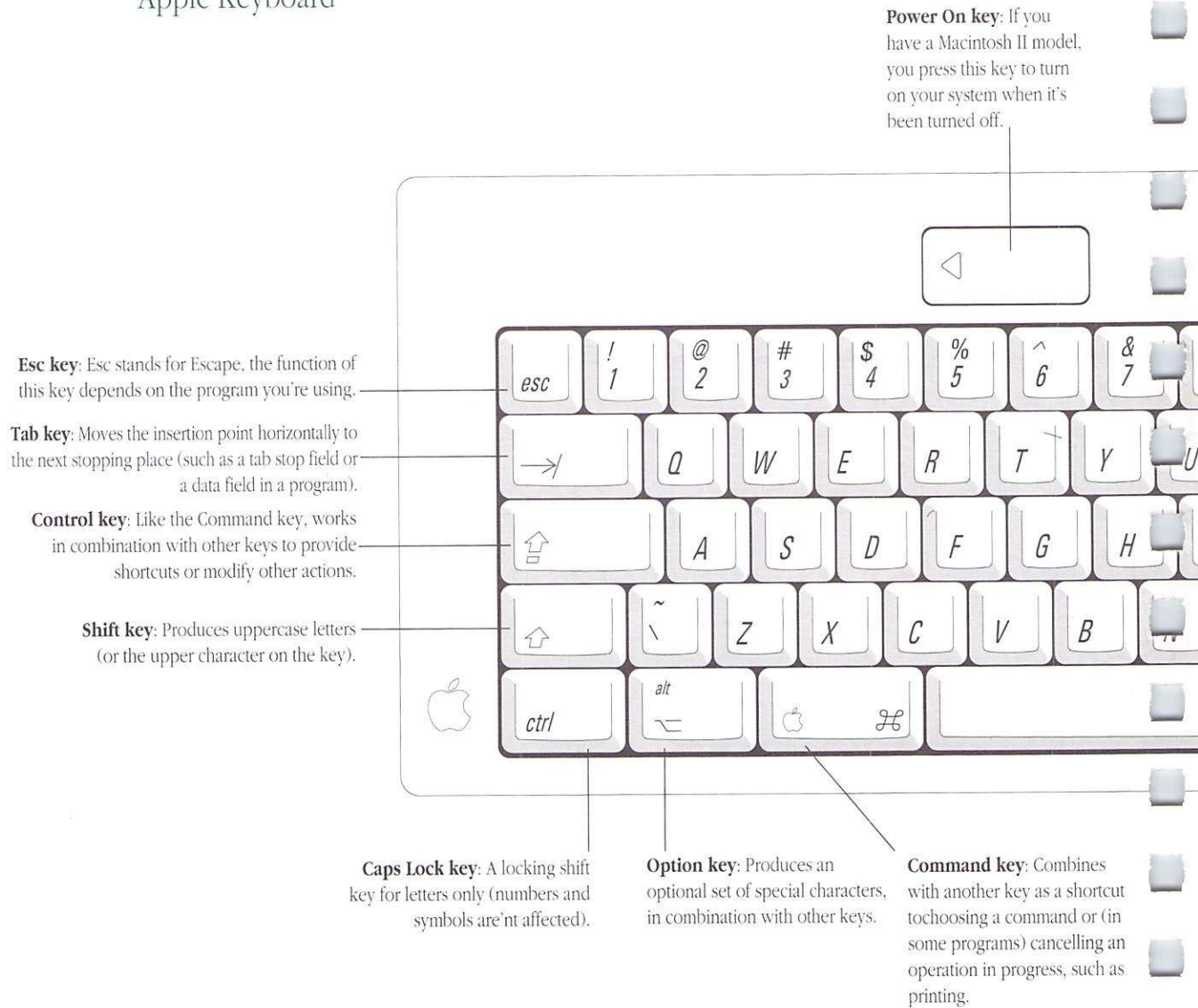

Figure A-2 The Apple keyboard

Delete key: Deletes any text currently selected, or whatever character is to the left of the insertion point.

Return key: Moves the insertion point to the beginning of the next line. In a dialog box, pressing Return is the same as clicking the outlined button.

Numeric key: These keys produce numbers and mathematical symbols; their arrangement matches that on the Calculator desk accessory.



Arrow key: Move the insertion point, as an alternative to using the mouse.

Clear key: Deletes the current selection, just as the Delete key does. In some programs, Clear may have other functions.

Enter key: In a dialog box, pressing Enter is the same as clicking the outlined button (or pressing Return); some programs require that you use Enter (not Return) to put data into specific fields.

Apple Extended Keyboard

Function keys: Designed to work in alternative operating systems such as A/UX or MS-DOS. With the help of the MacroMaker utility program, you can use these keys in the Macintosh Operating System.

Esc key: Esc stands for Escape, the function of this key depends on the program you're using.

Tab key: Moves the insertion point horizontally to the next stopping place (such as a tab stop field or a data field in a program).

Caps Lock key: A locking shift key for letters only (numbers and symbols aren't affected).

Shift key: Produces uppercase letters (or the upper character on the key).

Control key: Like the Command key, works in combination with other keys to provide shortcuts or modify other actions.

Option key: Produces an optional set of special characters, in combination with other keys.

Command key: Combines with another key as a shortcut to choosing a command or (in some programs) cancelling an operation in progress, such as printing.

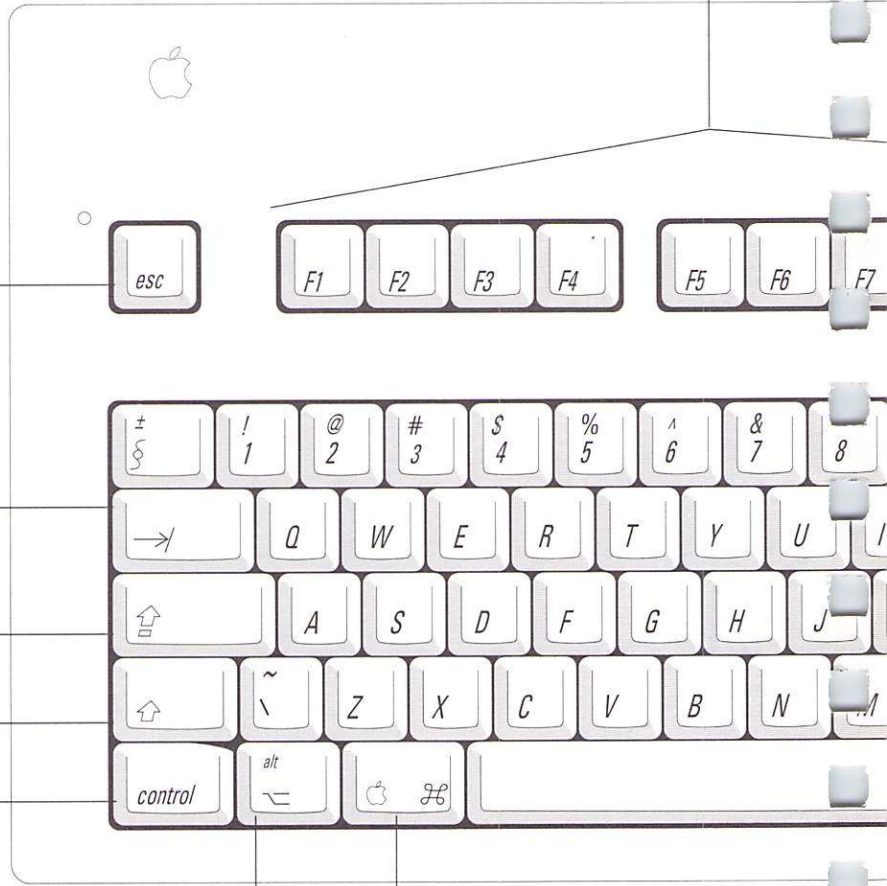

Delete key: Deletes any text currently selected, or whatever character is to the left of the insertion point.

Special keys: These keys are designed to work in alternative operating systems. In most cases, the function of these keys depends on the operating system and program you're using.

Numeric key: These keys produce numbers and mathematical symbols; their arrangement matches that on the Calculator desk accessory.

Power On key: If you have a Macintosh II model, you press this key to turn on your system when it's been turned off.

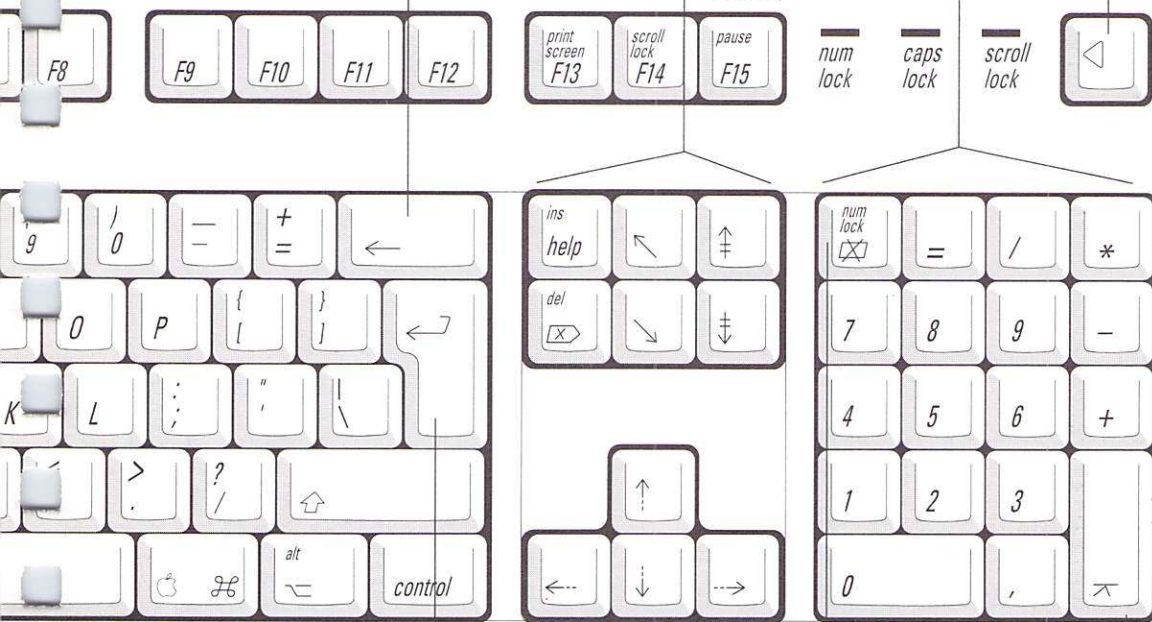

Return key: Moves the insertion point to the beginning of the next line. In a dialog box, pressing Return is the same as clicking the outlined button.

Arrow key: Move the insertion point, as an alternative to using the mouse.

Clear key: Deletes the current selection, just as the Delete key does. In some programs, Clear may have other functions.

Enter key: In a dialog box, pressing Enter is the same as clicking the outlined button (or pressing Return); some programs require that you use Enter (not Return) to put data into specific fields.

Optional characters

You can produce a variety of optional characters by pressing the Option key or Option-Shift keys in combination with certain character and number keys.

Viewing optional characters with Key Caps

The Key Caps desk accessory shows you the standard and optional character sets produced when modifier keys are pressed, such as the Shift and Option keys. Key Caps is supplied with the Macintosh system software and installed as part of the standard desk accessories on all Macintosh models with an internal hard disk.

You start Key Caps like any desk accessory—by choosing its name from the Apple menu.

Figure A-4 shows the Key Caps window with each of two sets of optional characters available in the Chicago font when the Option key is pressed and when Option-Shift is pressed on the Apple keyboard.

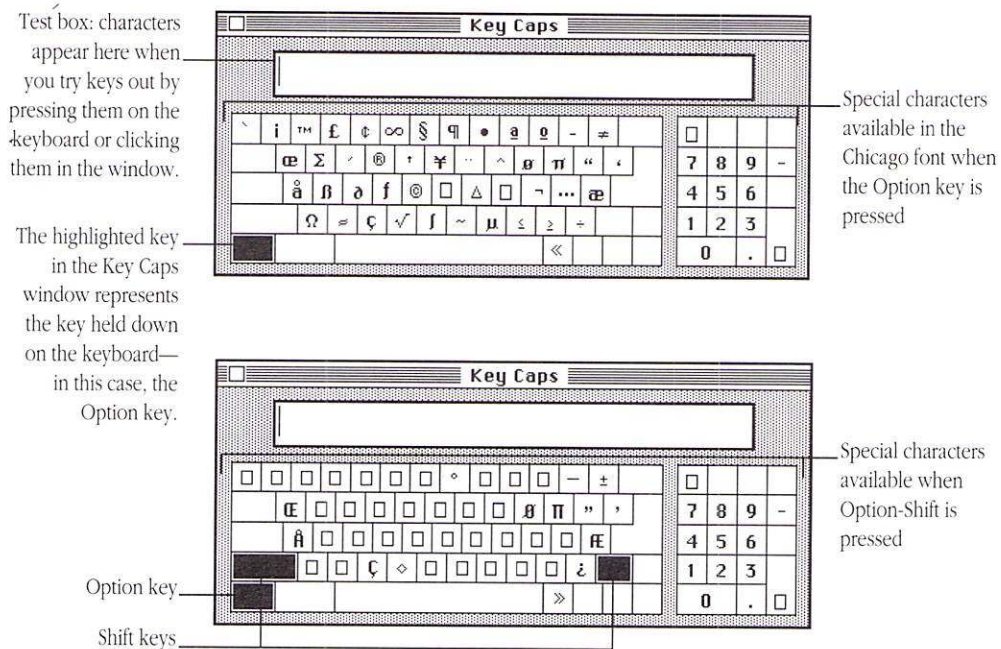

Figure A-4 Special characters displayed by the Key Caps desk accessory

The Control key available on some keyboards also produces optional characters for some keys.

You can display the character sets for other fonts installed in your System file by choosing the name of the font from the Key Caps menu when the Key Caps window is open. (See Figure A-5.)



Figure A-5 The Key Caps menu (available when Key Caps is in use)

Typing accented characters

Using the Option key with certain other keys lets you enter international language characters. Table A-1 shows the accent marks and the key combinations that produce them.

Table A-1 Option-key combinations for accent marks

Accent mark	Key combination
Grave accent (`)	Option-` , then type the character to be accented
Acute accent (´)	Option-e , then type the character
Circumflex (^)	Option-i , then type the character
Umlaut (¨)	Option-u , then type the character
The letter c with a cedilla (ç)	Option-c

MacroMaker Command Files

The MacroMaker™ utility program provided with the Macintosh system software lets you record keystrokes and commands in special files called *scripts* or *macros*, and assign the scripts to a key or a combination of keys on the keyboard. When you press the key or combination of keys that has a MacroMaker script, the script is “played.”

Installing MacroMaker

MacroMaker is supplied in the MacroMaker Folder on the *System Additions* disk. (If you are updating your system software with an upgrade kit, you'll find MacroMaker on *Utilities Disk 2*.) Figure B-1 shows the icons of the three files in the MacroMaker Folder.

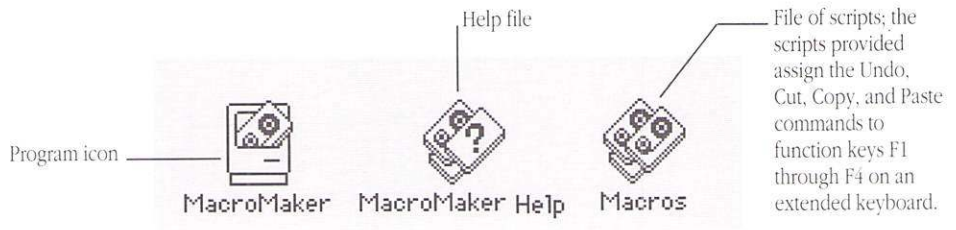

Figure B-1 Icons for the MacroMaker program, plus help and script files

To install MacroMaker, follow these steps:

1. Drag the icons for the program, its help file, and (if you have an extended keyboard) the script file "Macros" to the System Folder of your startup disk.
2. Restart the Macintosh.

Once the program is installed, a MacroMaker menu appears to the right of the other menus in the menu bar. The MacroMaker menu's title resembles a cassette tape. (See Figure B-2.)

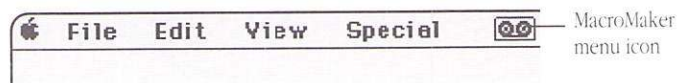

Figure B-2 The tape icon that identifies the MacroMaker menu

You remove MacroMaker by dragging its icons out of the System Folder of your startup disk and restarting the computer.

Creating macros with MacroMaker

You create a macro in the MacroMaker window. (See Figure B-3.)

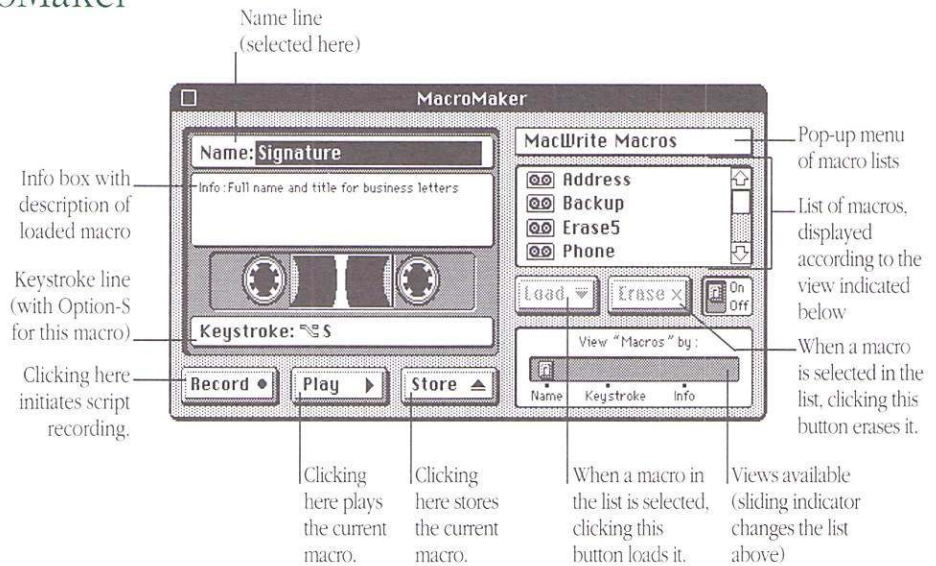

Figure B-3 The MacroMaker window

Follow these steps to create a macro.

1. Open a new document in the program you're using.

If you're working on the desktop (which means you're using the Finder), you can skip this step.

2. Open the MacroMaker window by choosing Open MacroMaker from the MacroMaker menu.
3. Type a name for the macro on the Name line.

The name can be up to 16 characters long.

4. If you want to add a description of the macro, click to select the Info box and type the information.

5. Click the **Keystroke** line to select it and type the keystroke or key combination that you want to trigger the macro.

You can include modifier keys, such as Command, Option, and Shift, in your keystroke; MacroMaker displays a symbol to represent each of these keys. (See Figure B-4.)



Figure B-4 Symbols for modifier keys used in keystrokes for macros

6. Click the **Record** button.

MacroMaker returns you to the current program. The cassette icon blinks in the menu bar to remind you that all keystrokes, mouse clicks, and menu commands you use will be recorded until you stop recording.

7. Enter the script you wish to record by typing, clicking, and choosing menu commands.

If you make a mistake while typing, use the Delete (Backspace) key to remove the incorrect characters.

8. To stop recording, choose **Stop Recording** from the **MacroMaker** menu.

Recording stops, and the MacroMaker window opens.

9. If you want to check your script, click the Play button.

MacroMaker returns you to the program in which you recorded the script, repeats the script, then reopens the MacroMaker window.

10. If you want to change the script, you can record it again without changing the name or keystroke.
11. Click the Store button to save the macro and move it into the macro list on the right side of the MacroMaker window.

If the list already contains a macro with the same name or keystroke, you'll see a dialog box asking if you want to replace the existing macro with the new one or to cancel the store command. If you cancel, you can rename the macro or change the keystroke and then store it.

If you don't store a macro and you close the MacroMaker window, you'll see a message asking if you want to store the macro before closing. If you don't store it, the macro will be lost.

- ❖ *Creating a global macro:* You can create a global macro, which is available regardless of the program you're using, by selecting Global Macros from the pop-up menu above the macro list box on the right side of the MacroMaker window, then following the regular steps to make a macro. Because menu commands vary among programs, it's a good idea to avoid using them in a global macro unless you're certain that they are provided on the same menu, at the same position, in all programs. ❖

- *See also:*
 - “Using Special Keys and Indicators on the Keyboard” in Chapter 1
 - Appendix A, “Keyboards and Character Sets”
 - Appendix D, “Special Aids for Using the Mouse, Keyboard, and Screen”

Exchanging Disks and Files With MS-DOS Computers

Some Macintosh models have the Apple SuperDrive as the internal floppy disk drive. The SuperDrive can read and initialize 3.5-inch disks for both Macintosh computers and for computers that use the MS-DOS operating system.

You use the utility program Apple File Exchange to initialize disks in the MS-DOS format and to convert files from MS-DOS computers for use in a Macintosh computer.

Using Apple File Exchange for MS-DOS disks and files

Apple File Exchange is supplied on one of the *System Additions* disk provided with Macintosh system software. (If you are updating your system software with an upgrade kit, you'll find Apple File Exchange on *Utilities Disk 2*.) The program and one or more special *translator* files, which convert files, are stored in the Apple File Exchange Folder.

Figure C-1 shows the Apple File Exchange icon.



Figure C-1 The Apple File Exchange icon

Initializing an MS-DOS disk in a SuperDrive

To initialize a 3.5-inch disk in MS-DOS format, follow these steps:

1. Start Apple File Exchange by double-clicking its icon.

The program's window opens, showing a directory dialog box that lists the contents of the active window on the left side and has an empty list box on the right side.

2. Place a blank high-density disk in the SuperDrive.

A dialog box appears, reporting that the program can't read the disk and asking if you want to initialize it. This dialog box shows the names of formats available in Apple File Exchange, including Macintosh and MS-DOS. (See Figure C-2.)

(You can initialize a disk that is not blank by inserting it, clicking the drive button until its name appears above the right list box in the Apple File Exchange window, and choosing Erase Disk from the File menu.)

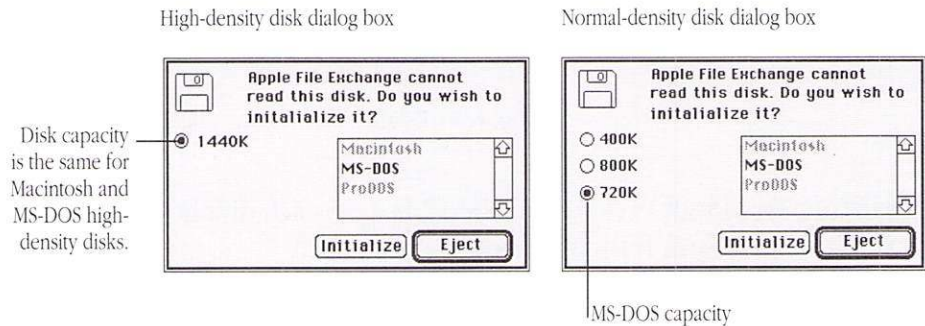

Figure C-2 Dialog boxes for initializing high-density and normal-density disks

3. Click MS-DOS, then click the Initialize button.

The disk is initialized in MS-DOS format. When initialization is completed, a dialog box appears, asking you to name the disk.

4. Type a name for the disk, then click OK.

The name must be valid for MS-DOS—up to 11 characters, with no period.

The dialog box closes, and the name of the disk you initialized appears in the Apple File Exchange window, above an empty directory. This disk's icon doesn't appear on your Macintosh screen (because it is in MS-DOS format).

5. Choose Quit from the File menu when you are finished using Apple File Exchange.

- ❖ *Initializing a normal-density disk in MS-DOS format:* You can also use Apple File Exchange to initialize a regular (normal-density) 3.5-inch disk for MS-DOS files. Follow the preceding steps, but place an 800K disk in a SuperDrive and click 720K in the dialog box that asks whether you want to initialize. (See Figure C-2.) ❖
- ❖ *5.25-inch disks:* Some Macintosh models can use an external 5.25-inch floppy disk drive that can read data files from MS-DOS disks. An internal adapter or expansion card is required to connect a 5.25-inch disk drive to the Macintosh. Apple File Exchange can translate files from these disks and store files on them. ❖

Converting files to and from MS-DOS format

Apple File Exchange converts Macintosh files into MS-DOS format and MS-DOS files into Macintosh format. The program provides two built-in methods of translation—text translation for use with text files, and binary translation, which copies a file in binary form.

In addition, Apple File Exchange can use separate translator files designed to convert files into formats for specific programs. One translator file provided with Apple File Exchange is the DCA-RFT/MacWrite file, which converts documents between MacWrite format for the Macintosh and Document Content Architecture/Revisable Form Text format (used by many word processing programs) for MS-DOS.

Figure C-3 shows the Apple File Exchange window with a Macintosh hard disk on the left and an MS-DOS disk on the right.

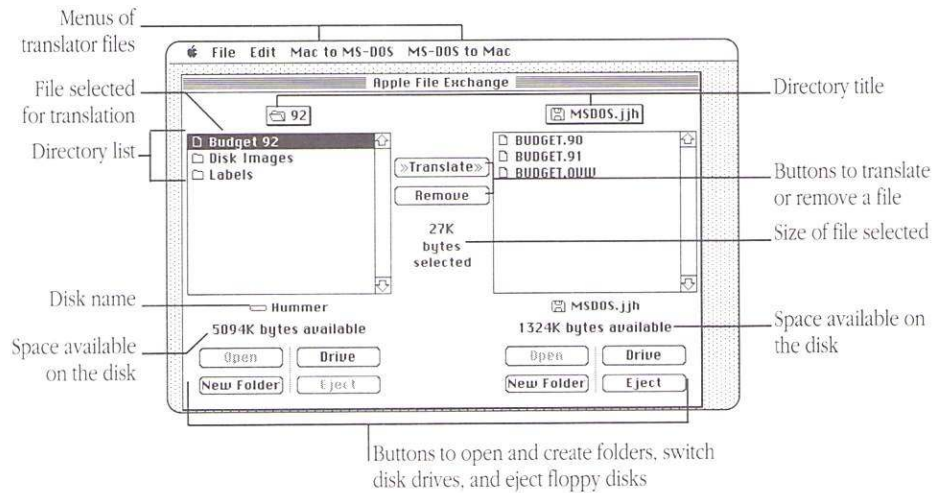

Figure C-3 The Apple File Exchange window and menu bar

Follow these steps to translate a file:

1. Start Apple File Exchange by double-clicking its icon.

The program's window opens, showing a directory dialog box that lists the contents of the active window on the left side and has an empty list box on the right side.

2. Use the Open, Drive, and Eject buttons, if necessary, to display the files you want to translate and the destination disk or folder where you want to store the translated files.

3. Click the name or names of the files or folders you want to translate to select them. To select multiple files or folders, hold down the Command key and click each name. You may have to scroll to locate the names of some files or folders.
4. Open the translation menu for the kind of file translation you want by pointing to its title and holding down the mouse button.

If you are translating MS-DOS files into Macintosh files, open the MS-DOS to Mac menu. This menu shows the DCA-RFT/MacWrite translator provided in the Apple File Exchange Folder, the built-in “Text translation” and “Default translation” (binary translation), and any other translators you’ve added. (See Figure C-4.)

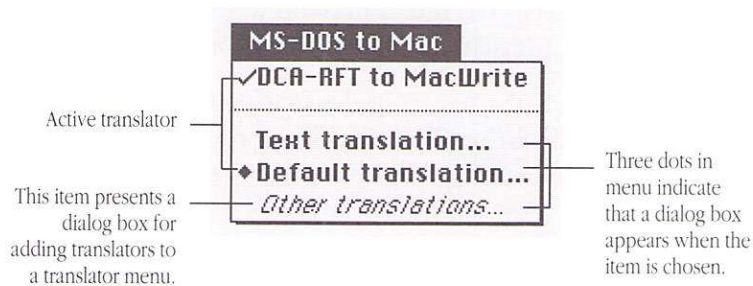

Figure C-4 The MS-DOS to Mac translator menu in Apple File Exchange

5. Make sure that all translators for the types of files you’ve selected are active; if not, select them.

An active translator has a check mark beside it or, for the default translator, a diamond (indicating that it’s always active). (Selecting an active translator makes it inactive.)

6. Compare the size of the files or folders selected for translation with the space available on the destination disk.

The total space for the items selected appears between the two directory lists; the space available on the destination disk appears below the name of the destination disk.

7. If the size of the selected items is greater than the space available on the destination disk, then either deselect some of the items selected, select and remove some files on the destination disk (using the Remove button), or change disks in the destination drive (using the Eject button).
8. When sufficient space is available for the selected items, click the Translate button.

If Apple File Exchange finds two or more active translators—other than Text or Default—capable of translating any selected file, it presents a dialog box asking you to select the translator you want from a list of active translators.

If the names of destination files or folders conflict with existing files or folders, or with each other, Apple File Exchange presents a dialog box in which you can rename the destination file.

If a translator requires you to select options before a file is translated, it presents a dialog box in which you select the options. (Translator names followed by three dots in a translator menu present an options dialog box.)

9. If necessary, select the appropriate translator from the list, and then either click the Continue button in the dialog box, rename the destination file and click Translate, or select the options you want and then click OK.

The selected files or folders are translated. A dialog box reports the status of copying, showing a horizontal bar that fills progressively with a gray pattern as the translation is completed.

If Macintosh files are being translated into MS-DOS files, the names of translated files are shortened to conform to the naming conventions of MS-DOS (maximum 11 characters, with a period between the eighth and ninth).

10. When all translations are finished, choose Quit from the File menu.
 - ❖ *Converting MS-DOS files on a file server:* Some file servers can store information created by Macintosh computers and MS-DOS computers. For example, the AppleShare PC program allows MS-DOS computers to store and translate files on an AppleShare file server. ❖

Other file-conversion options

Apple File Exchange provides several other options to assist you with file conversions. Figure C-5 shows the program's File menu, where you choose these options.

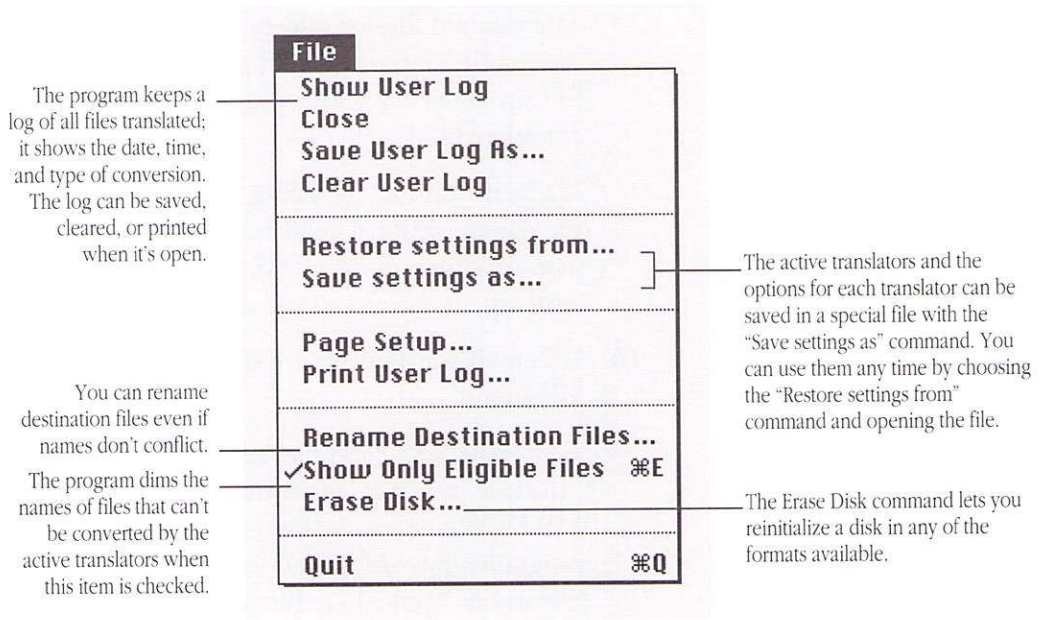

Figure C-5 The File menu options in Apple File Exchange

More information about Apple File Exchange options

The program itself contains explanations of the translators it uses. Choose About the Apple File Exchange from the Apple menu to see the list of translators, select an item in the list, then click the About button for information about that item. (Click the Done button to return to the program's window.)

Converting Apple II files with Apple File Exchange

You can also translate files to and from the format for the ProDOS™ operating system for Apple II computers. Apple File Exchange converts ProDOS files to and from Macintosh format and MS-DOS format. You can obtain translators for ProDOS and other operating systems from your authorized Apple dealer.

Special Aids for Using the Mouse, Keyboard, and Screen

The Macintosh system software includes utility programs designed to assist users who have difficulty using the keyboard or the mouse or reading the monitor's screen. These programs are Easy Access, which provides alternative ways to use the mouse and keyboard, and CloseView™, which magnifies the images displayed on the screen.

Keyboard and mouse assistance with Easy Access

Easy Access is a file in your System Folder that provides two features—Sticky Keys and Mouse Keys. These features assist people who have difficulty typing with both hands or with manipulating the mouse. They're also useful to anyone who wants to use the keyboard with one hand or to make very fine movements of the pointer with better control.

Easier keyboard use with Sticky Keys

The Sticky Keys feature of Easy Access lets you type combination keystrokes, consisting of a modifier key and another key, without actually pressing the keys simultaneously. The modifier keys covered by Sticky Keys are

- Shift key
- Command key
- Option key
- Control key (not on the Macintosh Plus keyboard)

To use Sticky Keys, follow these steps:

1. Press the Shift key five times without moving the mouse.

(If you bump or move the mouse during this sequence, begin again.)

When you turn Sticky Keys on, its icon appears at the far-right end of the menu bar. (See Figure D-1.)

2. Press the key combination you want to use.

When you press a modifier key, the Sticky Keys icon changes to indicate that the modifier key is set or locked. (See Figure D-1.) Pressing a modifier key once sets it; pressing the key twice locks it.

3. To turn off Sticky Keys, press the Shift key five times again.

You can also turn off Sticky Keys by pressing any two modifier keys at the same time.

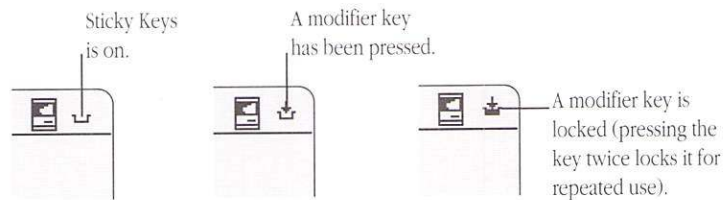

Figure D-1 Icons for the Sticky Keys feature of Easy Access

Easier mouse use with Mouse Keys

The Mouse Keys feature of Easy Access lets you manipulate the pointer using the numeric keypad on your keyboard instead of the mouse. You can click, drag, and perform all the usual mouse activities, and you can gain precise control of mouse movements when needed.

To use Mouse Keys, follow these steps:

1. To turn on Mouse Keys, press **Command-Shift-Clear**. (You can use **Sticky Keys** for this combination if you wish.)
2. Use the numeric keypad to move the pointer and to click, drag, and make other mouse movements.

Figure D-2 shows the pointer movement produced by pressing keys on the numeric keypad. The 5 key serves as the mouse button: press once to click; press twice to double-click. The 0 key locks the mouse button down for dragging. The decimal point key (to the right of 0) unlocks the mouse button.

3. To turn off Mouse Keys, press **Command-Shift-Clear** again.



Figure D-2 Pointer movements and mouse control with Mouse Keys turned on

- *See also:*
- “Using Special Keys and Indicators on the Keyboard” in Chapter 1
 - Appendix A, “Keyboards and Character Sets”
 - Appendix B, “MacroMaker Command Files”

Easier screen viewing with CloseView

CloseView is a utility program supplied with Macintosh system software that makes the screen easier to view or read for people who have difficulty with standard-sized screen images.

You install CloseView by dragging its icon to the System Folder of your startup disk. (See Figure D-3.)

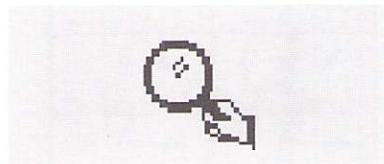

Figure D-3 The CloseView icon

You turn CloseView on and select its features in the Control Panel. With the General Control Panel open, locate and click the CloseView icon to display the CloseView Control Panel. (See Figure D-4.) Then select the options you want to use.

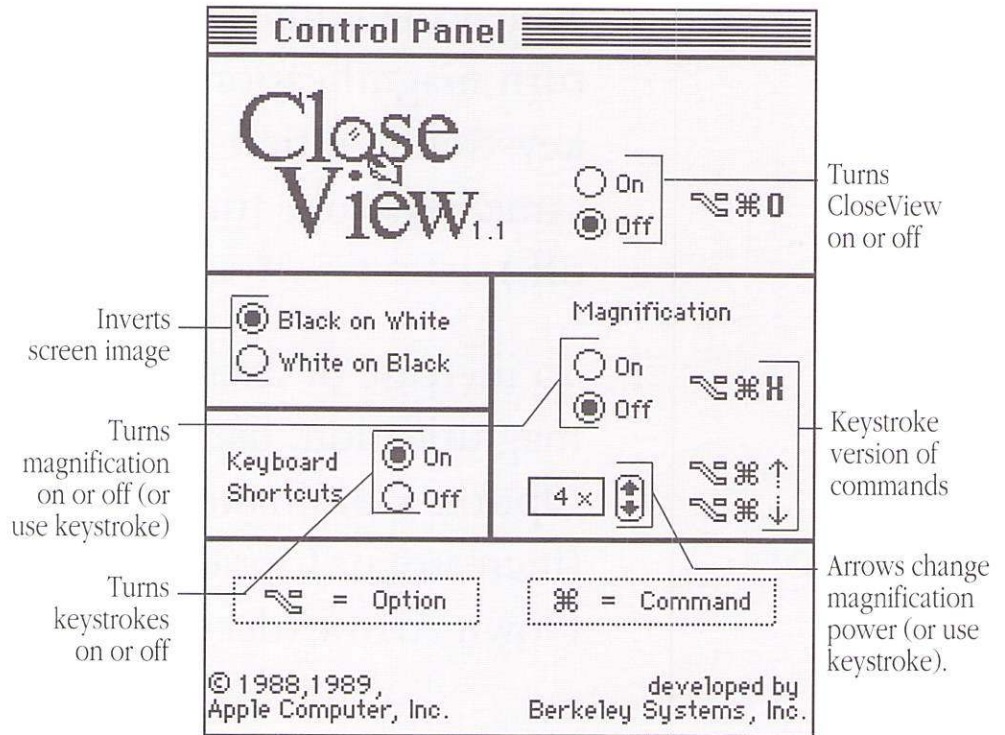

Figure D-4 CloseView Control Panel

When CloseView is on, you'll see its frame (a heavy box covering a portion of the screen). The frame moves when you move the pointer on the screen.

When the frame is displayed, you can turn magnification on with the keystroke Option-Command-X. (The same keystroke turns magnification off.)

To increase or decrease the power of magnification, use the keystroke Option-Command-Up Arrow (increase) or Option-Command-Down Arrow (decrease).

Where to Get More Information About Your Macintosh

As you increase your knowledge of computers and develop new uses for your Macintosh, you may want to learn more about programming, hardware design, or other technical topics. Or you may simply want to know what other Macintosh users in your area are doing with their computers.

The information presented in this appendix provides a starting point for you to expand your Macintosh knowledge and contacts, no matter what your interests.

Macintosh user groups

Whatever your level of computer experience, you can get lots of support by joining a Macintosh user group. Macintosh user groups are composed of people who work with Macintosh computers and who enjoy sharing what they know with others. Activities may include new product demonstrations, information question-and-answer sessions, and regular classes on using popular programs or learning to write your own programs. Many user groups have special beginners' meetings.

Ask your authorized Apple dealer for the name of the Macintosh user group nearest you, or call 1-800-538-9696 for more information. For user groups outside the United States, or if you're interested in starting your own user group, contact

Berkeley Macintosh User Group	or	Boston Computer Society
1442-A Walnut Street, #62		One Center Plaza
Berkeley, CA 94709		Boston, MA 02108
(415) 849-9114		(617) 367-8080

Technical information

A variety of technical documentation is available for the Macintosh. Apple Computer releases technical information through three primary outlets: the Apple Technical Library and the Apple Communications Library, both published by Addison-Wesley Publishing Company, and APDA™.

Apple Technical Library

The Apple Technical Library includes comprehensive technical documentation for all Macintosh computer models and the multiple-volume guide to the Macintosh operating system for all models, *Inside Macintosh*.

Other books in the Apple Technical Library cover design of expansion cards and programming of device drivers for the Macintosh, programming for the Macintosh, and designing the user interface for Macintosh programs.

You'll find the Apple Technical Library in most well-stocked bookstores.

Apple Communications Library

The Apple Communications Library offers complete technical information about Macintosh communications products and the Macintosh in a network environment. The library includes an introductory volume, *Understanding Computer Networks*, and the comprehensive guide to the AppleTalk network system, *Inside AppleTalk*.

The books in the Apple Communications Library are available in bookstores.

APDA

APDA provides a wide range of technical products and documentation, from Apple and other suppliers, for programmers and developers who work on Apple equipment. For information about APDA, contact

APDA
Apple Computer, Inc.
Mailstop 33-G
20525 Mariani Avenue
Cupertino, CA 95014

1-800-282-APDA (1-800-282-2732)
FAX: (408) 562-3971
Telex: 171-576
AppleLink: APDA

Assistance for hardware and
software developers

If you plan to develop hardware or software products for sale through retail channels, you can get valuable support from Apple Developer Programs. Write to

Apple Developer Programs
Apple Computer, Inc.
Mailstop 75-2C
20525 Mariani Avenue
Cupertino, CA 95014-6299

Glossary

A

active application The application program currently being used. With MultiFinder, a number of application programs can be open, but only one of them is the active application. The active application is represented by a small icon at the top-right corner of the menu bar. You can switch from one application to another by clicking the icon.

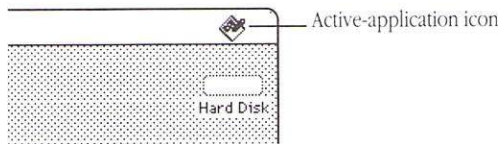

active window The frontmost window on the desktop, where the next action will take place. An active window's title bar is highlighted (with a series of lines).

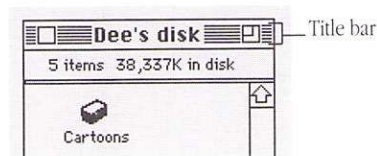

ADB See **Apple Desktop Bus**.

Alarm Clock A desk accessory that displays the current time and date, and can be set to function as an alarm.

alert box A box that appears on the screen to give a warning or to report an error message during use of an application program. Its appearance is usually accompanied by a beep.

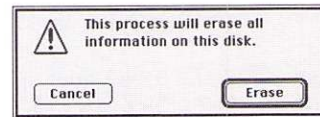

Apple Desktop Bus (Abbreviated *ADB*.) Built-in circuitry of Apple computers. Apple Desktop Bus ports are on the computer's back panel and marked with a "branching" icon. You use them to attach the keyboard, mouse, and other devices, such as graphics tablets, hand controls, and specialized keyboards. See also **bus**.



Apple menu The menu farthest to the left in the menu bar, indicated by an Apple symbol, from which you choose application programs and desk accessories.

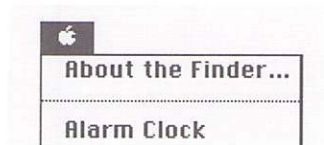

AppleTalk network The AppleTalk connectors, cables, cable extenders, and software that link computers and peripheral devices—such as printers or file servers—together in a network. AppleTalk capability is built into every Macintosh and most LaserWriter models.

application program A program written for some specific purpose, such as word processing, database management, graphics, or telecommunication. Most application programs are represented by icons that show a hand working with a document.



audio jack A connector on the back panel of the Macintosh marked with a “sound” icon. You use the audio jack to attach headphones or other audio devices.



B

back panel The rear surface of the computer, which includes the power switch, the power connector, and ports for peripheral devices.

back up (v) To make a copy of a disk or of a file on a disk. Backing up your files and disks ensures that you won't lose information if the original is lost or damaged.

bit A contraction of *binary digit*. The smallest unit of information that a computer can hold. The value of a bit (1 or 0) represents a simple two-way choice, such as on or off, true or false, black or white, and so on.

bitmap A set of bits that represents the graphic image of an original document in memory. Used by the Macintosh to construct graphic images and typefaces.

bitmapped character A character that exists in a computer file or in memory as a bitmap, is drawn as a pixel pattern on the graphics screen, and is sent to the printer as graphics data. See also **pixel**.

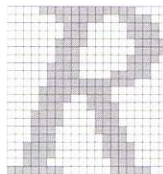

bitmapped font A font made up of bitmapped characters. For example, fonts stored in a Macintosh System file are bitmapped fonts.

buffer A “holding area” in memory where information can be stored by one program or device and then read at a different rate by another. For example, some printers have built-in memory to store text coming from the computer faster than it can be printed. This memory is called a *print buffer*.

bus Circuits inside the computer that transmit information from one part of a computer system to another; for example, the Apple Desktop Bus. In a network, a bus is a line of cable with connectors linking devices together.

button A pushbutton-like image in dialog boxes which you click to designate, confirm, or cancel an action. Compare **mouse button**.



byte A unit of information consisting of a fixed number of bits. One byte usually consists of a series of eight bits, and represents one character (such as a letter, numeral, or punctuation mark). See also **kilobyte**, **megabyte**.

C

cache See **memory cache**, **RAM cache**.

Calculator A desk accessory that works like a four-function pocket calculator. Calculation results can be cut and pasted into your documents using the Cut and Paste commands from the Edit menu.

Cancel button A button that appears in some dialog boxes. Clicking it cancels the command just chosen.

central processing unit (Abbreviated *CPU*.) The “brain” of the computer; the microprocessor that performs the actual computations. See also **processor**, **coprocessor**.

character Any symbol that has a widely understood meaning and thus can convey information, such as the letters, numerals, and punctuation marks indicated on the computer’s keyboard.

check box A small box associated with an option in a dialog box or window. When you click the check box, you may change the option or affect related options.

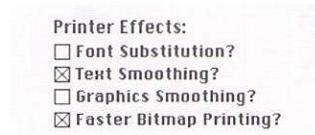

chip See integrated circuit.

choose To pick a command by dragging through a menu. You normally choose a command after you’ve selected something for the command to act on.

Chooser A desk accessory that lets you designate devices, such as printers, that your Macintosh will use.

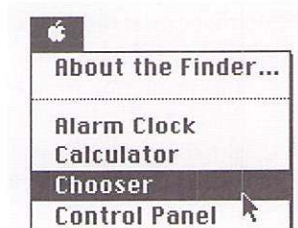

Clear A command in the Edit menu that removes selected material without placing it on the Clipboard. You can use the Undo command immediately after using Clear if you change your mind. Compare **Cut**.

click To position the pointer on something, and then to press and quickly release the mouse button. Clicking is normally used to select an icon, a word or object in a document, a choice in a window, or to confirm a choice in a dialog box.

Clipboard An area in the computer's memory that functions as a holding place for what you last cut or copied. Information on the Clipboard can be pasted into documents.

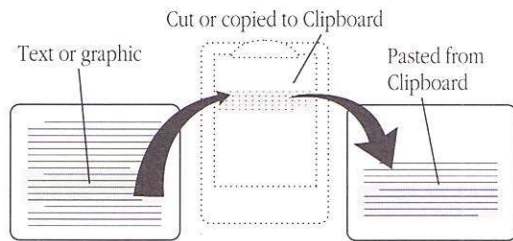

close box The small white box on the left side of an active window's title bar. Clicking it closes the window.



color wheel A feature that appears in a dialog box when you click the Change Color button in the Control Panel desk accessory. The color wheel lets you adjust hue, saturation, and brightness of the highlight color. It is also used to adjust shades of gray.

command An instruction that causes the computer to perform some action. The most common form of Macintosh commands are the commands listed in a menu. These are chosen by using the mouse and pointer. Others can be typed from a keyboard.

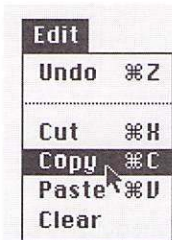

configuration (1) A general-purpose computer term that can refer to the way you have your computer set up. (2) The combined hardware components—computer, monitor(s), keyboard, and peripheral devices—that make up a computer system. (3) The software settings that allow various hardware components of a computer system to communicate with each other.

Control Panel A desk accessory that lets you change various Macintosh features, such as speaker volume and keyboard repeat speed and delay.

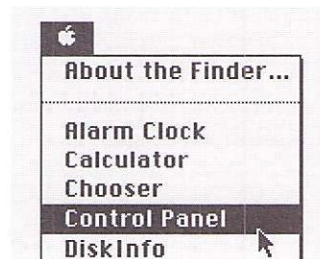

coprocessor An auxiliary processor designed to relieve the demand on the main processor by performing a few specific tasks. Generally, coprocessors handle tasks that could be performed by the main processor but much more slowly.

Copy A command in the Edit menu that copies selected material and places it on the Clipboard, without removing the material from the original document. See also **Clipboard**.

copy-protect To make a disk uncopyable. Software publishers sometimes copy-protect their disks to prevent them from being illegally duplicated. See also **lock**.

CPU See **central processing unit**.

current application See **active application**.

current startup disk The disk that contains the System file the computer is currently using. The startup disk icon always appears in the upper-right corner of the desktop.

cursor See **pointer**.

Cut A command in the Edit menu that removes selected material and places it on the Clipboard; from there you can paste it elsewhere. Compare **Clear**. See also **Clipboard**.

cut and paste To move something from one place in a document to another in the same document or a different one. It's the computer equivalent of using scissors to clip something and glue to paste the clipping somewhere else.

D

data disk A disk that contains your work—letters, budgets, pictures, and so on—in the form of documents.

default A value, action, or setting that a computer system assumes, unless you give it a different instruction. (Also called *preset*.)

deselect To change a selected item, such as an icon, so that it is no longer selected. On the desktop, you deselect highlighted icons by pressing the Shift key and clicking the icon you want to deselect, or by selecting something else without pressing the Shift key.

desk accessories “Mini-application programs” that are available from the Apple menu at all times, regardless of the program you're using. Desk accessories provided with the Macintosh include the Alarm Clock, Calculator, Chooser, Control Panel, Find File, Key Caps, and Scrapbook. You use the Font/DA Mover to install desk accessories.

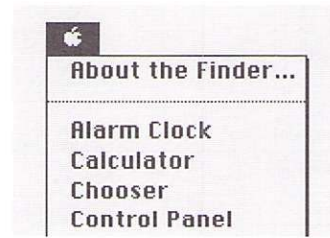

desktop Your working environment on the computer—the menu bar and the background area on the screen. You can have a number of documents open on the desktop at the same time.

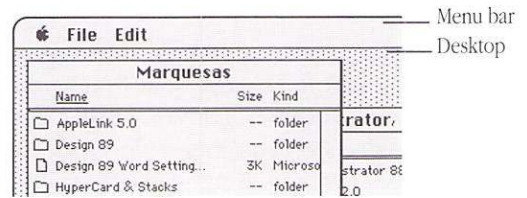

destination The disk or folder that receives a copied or translated file, as in *destination disk*.

dialog box A box that contains a message, often requesting more information from you. Sometimes the message is accompanied by a beep.

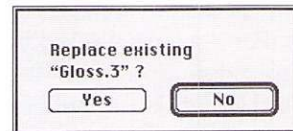

dimmed A term used to describe words or icons that appear in gray. For example, menu commands appear dimmed when they are unavailable. A dimmed icon represents an opened disk or folder, or a disk that has been ejected. Double-clicking a dimmed disk or folder icon causes the window for the disk or folder to become the frontmost, or active, window.

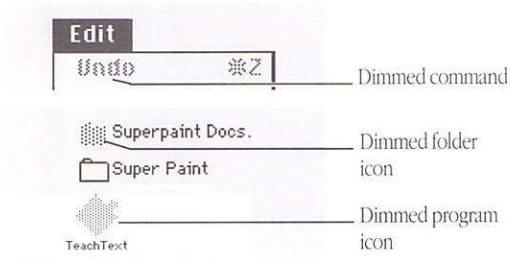

directory A list of the contents of a folder or a disk. By using commands from the View menu, you can set a directory window to present this list pictorially, alphabetically, chronologically, or according to size.

directory dialog box A type of dialog box you use to locate files and change disks from within an application program. Directory dialog boxes appear whenever you choose the Open or Save As commands from within an application program.

disk A flat, circular, magnetic surface on which information can be recorded in the form of small magnetized spots, in a manner similar to the way sounds are recorded on tape. See **floppy disk**, **hard disk**.

disk capacity The maximum amount of data a disk can hold, usually measured in kilobytes (K) or megabytes (MB). For instance, Apple 3.5-inch disks typically have a disk capacity of 400K, 800K, or 1.4 MB. Hard disks can hold from 20 MB to 160 MB, and some even more.

disk drive The device that holds a disk, retrieves information from it, and saves information on it. All models of Macintosh computers contain at least one built-in disk drive.

document Whatever you create with an application program. Documents are usually represented by icons derived from the icons of the programs that created them. See also **file**.



double-click To position the pointer on an object, such as an icon, and then press and release the mouse button twice in quick succession without moving the mouse. Double-clicking an icon opens the document, application program, or disk that the icon represents.

drag To position the pointer on something, press and hold the mouse button, move the mouse, and release the mouse button. When you release the mouse button, you either confirm a selection or move an object to a new location.

driver A system program that allows the microprocessor to direct the operation of a peripheral device, such as a printer or scanner. (Also called a *resource*.) Drivers are represented by icons; to begin using drivers with the devices connected to your Macintosh, you usually drag their icons to your System Folder and restart the computer.



E

Easy Access A feature of Macintosh system software that assists people who have difficulty typing on the keyboard or manipulating the mouse.

Edit menu A menu that is available in most programs and lists editing commands—such as Cut, Copy, and Paste.

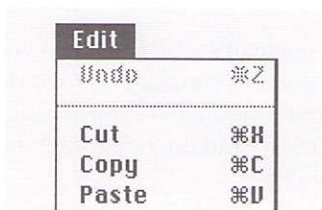

eject To remove a disk from a disk drive.

error message A displayed message that tells you of an error or problem in the execution of a program or in your communication with the computer system. An error message is often shown in an alert box and accompanied by a sound.

expansion card A removable circuit board that plugs into expansion slots in some models of Macintosh computers. Expansion cards enable the computer to use some types of devices or to perform special functions.

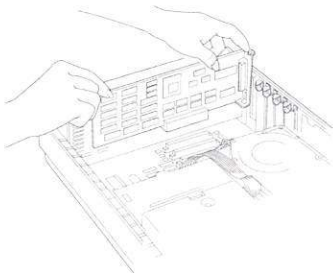

expansion slot A long, thin socket on the main circuit board of some Macintosh models into which you can install an expansion card that expands the computer's capabilities.

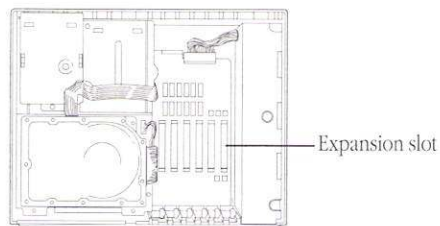

F, G

file server A combination of a mass-storage device (such as a hard disk) and software that allows computer users to share common files and application programs through a network.

file Any named, ordered collection of information stored on a disk. Application programs and documents are examples of files. You make a file when you create text or graphics, give the material a name, and save it on a disk.

File menu A menu that lists commands that affect whole documents—commands such as Save, Print, and Quit.

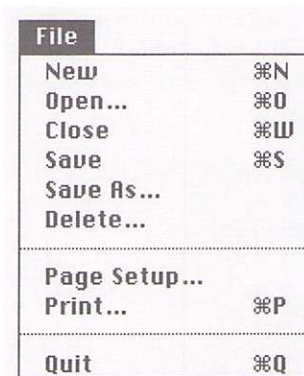

Finder A part of Macintosh system software that's always available, creating the desktop environment. You use the Finder to manage documents and application programs, and to get information to and from disks.



Find File A desk accessory that enables you to find any folder or file on a disk.

floppy disk A disk made of flexible plastic that stores computer data. The 3.5-inch disks used in Macintosh disk drives are floppy disks housed in rigid, plastic containers for support and protection.

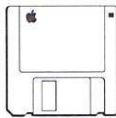

folder A holder for documents, programs, and other folders on the desktop. Folders let you organize information in any way you want.

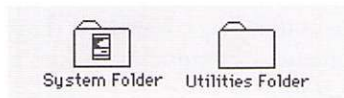

font A collection of letters, numbers, punctuation marks, and other typographical symbols with a consistent appearance; the size and style can be changed readily.

This is New York font.

This is Geneva font.

Font/DA Mover A utility program, supplied with Macintosh system software, that lets you add or remove fonts and desk accessories from a disk's System file.



format See **initialize**.

H

hard disk A disk made of metal and permanently sealed into a drive or cartridge. A hard disk stores very large amounts of information (20 MB–160 MB) and operates much faster than a floppy disk.

I, J

I-beam A type of pointer shaped like the capital letter 'I' and used for entering and editing text. See also **insertion point**.

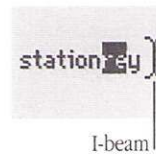

icon An image that represents an object, a concept, or a message. For example, an unopened HyperCard stack's icon looks like a stack of cards; a floppy disk's icon is a miniature of that type of disk.

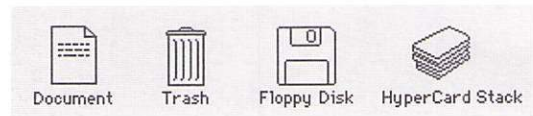

initialize To prepare a blank disk to receive information by organizing its surface into tracks and sectors; same as *format*.

input Information transferred into a computer from some external source, such as the keyboard, the mouse, a disk drive, or a modem. Compare **output**.

insertion point The place in a document where something will be added; it is placed by clicking at the spot where you want to make the change and is represented by a blinking vertical bar.

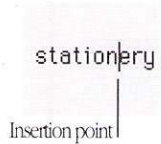

Installer A program that lets you install or update your system software or add resources.



integrated circuit (IC) An electronic circuit entirely contained in a single piece of semiconducting material, usually silicon. Often referred to as a *chip*.

interface The point of communication between a person and a computer. Often referred to as the computer's *human interface* or *user interface*.

K

K See **kilobyte**.

Key Caps A desk accessory that shows you the optional character set available for a given font family.

keyboard equivalent A combination of key presses that you can use instead of a mouse action to perform a task. Keyboard equivalents almost always include the Command key, and are convenient alternatives to using the mouse to choose menu commands. Also called a *Command-key equivalent* or *keyboard shortcut*.



kilobyte A unit of measurement consisting of 1024 bytes. See also **byte**, **megabyte**.

L

LocalTalk cable system A system of cables, cable extenders, and connector boxes that connect computers and network devices as part of the AppleTalk network system.

lock To prevent files or disks from being altered.

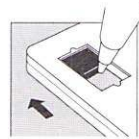

Individual files are locked with software commands. A disk can be physically locked by sliding the small tab on the back of the plastic case of a 3.5-inch disk toward the edge of the disk.

M

main logic board A large circuit board that holds RAM, ROM, the microprocessor, custom-integrated circuits, and other components that make the computer work.

main memory The part of a computer's memory whose contents are directly accessible to the microprocessor; usually synonymous with random-access memory (RAM). Programs are loaded into main memory, where the computer keeps information while you're working. Sometimes simply called *memory*. See also **random-access memory**, **read-only memory**.

megabyte (MB) A unit of measurement equal to 1024 kilobytes, or 1,048,576 bytes. See also **byte**, **kilobyte**.

memory A hardware component of a computer system that can store information for later retrieval. See **main memory**, **random-access memory**, **read-only memory**.

memory cache Memory that is dedicated to increasing the efficiency and operating speed of the computer. Some models of Macintosh computers offer an internal connector for an optional memory cache card. Compare **RAM cache**.

menu A list of actions from which you can choose. Menus commonly appear when you point to and press menu titles in the menu bar or in a dialog box. You choose a command by dragging through the menu and releasing the mouse button when the command you want becomes highlighted.

menu bar The white strip across the top of your screen that contains the titles of the menus available to you.

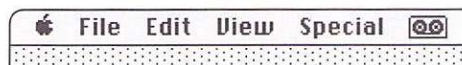

menu title A word, phrase, or icon that is in the menu bar and that designates one menu. Positioning the pointer on a menu title and holding down the mouse button causes the title to be selected and its menu to appear below it. You then drag to choose a command.

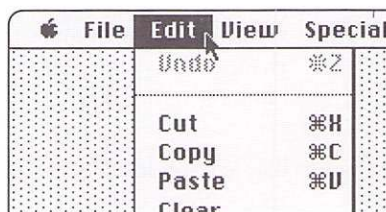

modem Short for *modulator/demodulator*. A device that links your computer to other computers and information services over telephone lines.

modem port A connector on the computer's back panel marked by a telephone icon. A port that you can use to attach a modem to the computer, or to connect the computer to the AppleTalk network system.



monitor See **video monitor**.

mouse A small device that controls a pointer on the screen. When you move the mouse on a flat surface, the pointer moves.

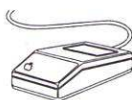

mouse button The mechanical button on top of the mouse. In general, pressing the mouse button initiates some action on whatever is under the pointer on the screen, and releasing the button confirms the action.

Mouse Keys An Easy Access feature that lets you use keys on the numeric keypad to move the pointer.

MS-DOS An acronym for Microsoft Disk Operating System. This is the operating system for computers manufactured by many computer companies.

MultiFinder A part of Macintosh system software that allows the computer to use multiple programs simultaneously by alternating between programs. An icon at the top-right corner of the menu bar shows the current application program. Clicking the icon changes applications.

N

network A collection of interconnected, individually controlled computers, together with the hardware and software used to connect them. A network lets users share data and peripheral devices such as printers and file servers, exchange electronic mail, and so on.

Note Pad A desk accessory that lets you enter and edit small amounts of text while working on another document.

NuBus An address bus and data bus incorporated into the Macintosh II line of computers. NuBus lets you add a variety of components to the computer system, through expansion cards installed in NuBus expansion slots inside the computer. See **expansion slot**.

numeric keypad A calculator-style keypad, to the right of the main keyboard, that you can use to type numbers. The layout of numbers on the keypad makes it easier and faster to use than the number keys on the regular keyboard. Some application programs designate the keys on the numeric keypad as special function keys.



O

open To make available. You open files in order to work with them. Opening an icon causes a window to come into view, revealing the document or application program the icon represents. You may then perform further actions on the contents of the window.

operating system A program that organizes the internal activities of the computer and its peripheral devices; an operating system performs basic tasks such as moving data to and from devices, managing information in memory, and so on.

output Information transferred from the computer's microprocessor to some external device, such as the display screen, a disk drive, a printer, or a modem. Compare **input**.

P, Q

password A secret word that gives you, but no one else, access to your data or to messages sent to you through electronic mail or an information service.

Paste A command in the Edit menu that puts the contents of the Clipboard—whatever was last cut or copied—at the insertion point. See also **Clipboard**.

peripheral device A piece of hardware—such as a video monitor, disk drive, printer, or modem—used with a computer and under the computer's control. Peripheral devices are often (but not always) physically separate from the computer and connected to it by cables.

pixel Short for *picture element*. The visual representation of a bit on the screen (white if the bit is 0, black if it's 1). Also a location in video memory that corresponds to a point on the screen. See also **bit**.

pointer An arrow or other symbol on the screen that moves as you move the mouse.



You use the pointer to choose commands, move data, and draw in graphics programs.

port A socket on the back panel of the computer where you can plug in a cable to connect a peripheral device, another computer, or a network.

printer port A connector on the computer's back panel marked with a printer icon. A serial port that you can use to attach a printer to the computer, or to serve as an attachment point for an AppleTalk connector.



processor The computer hardware component that performs the actual computations directed by software commands. In microcomputers such as the Macintosh, the processor is a single integrated circuit called a microprocessor. See also **central processing unit**.

program A set of instructions describing actions for a computer to perform to accomplish a task, conforming to the rules and conventions of a particular programming language. Computer programs are collectively referred to as *software*.

pull-down menu A menu that is hidden until you move the pointer to its title and press the mouse button. See also **menu**, **menu bar**, and **menu title**.

R

RAM See **random-access memory**.

RAM cache A portion of the Macintosh main memory (RAM) that you can set aside for special use. You use the Control Panel to turn the RAM cache on or off. Compare **memory cache**.

random-access memory (Abbreviated *RAM*.) Memory in which information can be referred to in an arbitrary or random order. RAM usually means the part of memory available for programs and documents that the computer reads from a disk; the contents of RAM are lost when the computer is turned off. Compare **read-only memory**.

Read Me document A document that is included on some application program and system software disks to provide you with late-breaking information about the product.

read-only memory (Abbreviated *ROM*.) Memory whose contents can be read, but not changed. Information is placed into read-only memory only once, during manufacturing. The contents of ROM are not erased when the computer's power is turned off. Compare **random-access memory**.

resource A file that is contained in the System Folder and that the computer uses for its operations. System files and drivers are examples of resources.

RGB monitor A type of color monitor that receives separate signals for each color (red, green, and blue).

ROM See **read-only memory**.

S

save To store information by transferring it from main memory (RAM) to a disk. Work not saved disappears when you turn off the computer or when the power is interrupted. It's a good idea to save your work frequently so that you lessen the risk of losing data.

scanning order The order in which the operating system searches the disk drives for a startup disk. See also **startup disk**.

Scrapbook A desk accessory in which you can save frequently used pictures or passages of text. The Scrapbook can store multiple images. You can cut, copy, or paste images from the Scrapbook into documents created with most application programs. Compare **Clipboard**; see also **cut and paste**.

screen fonts The fonts provided with Macintosh system software; also known as bitmapped fonts. You use a version of the font for each size of type you want to display on the screen. (A different version of fonts is used for printing.)

scroll To move a document or directory in its window so that a different part of it is visible. To scroll through a document or directory, you use the scroll arrows, scroll bars, or the scroll box.

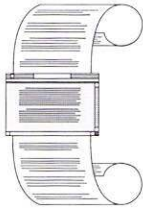

SCSI See **Small Computer System Interface**.

SCSI cable terminator A device used in a SCSI chain to maintain the integrity of the signals passing along the SCSI chain. A SCSI chain should always have two terminators, one at each end of the chain. With some devices, the terminator is built-in.

SCSI chain A group of SCSI devices linked to one another through SCSI peripheral interface cables and linked to the SCSI port on the computer through a SCSI system cable.

SCSI port The connector on the back panel of the computer to which you connect SCSI devices.



select To designate where the next action will take place. To select something with a mouse, you click an icon or drag across text or graphics.

selection The information or items that will be affected by the next command. A selected item is usually highlighted.

serial ports The connectors for peripheral devices that receive data in a serial format (that is, one bit at a time), such as the printer and modem ports on the Macintosh.

Shift-click A technique that allows you to extend or shorten a selection by holding down the Shift key while you select (or deselect). You can also Shift-click multiple items in a list or group to select them all.

Shift-drag A technique that allows you to select two or more groups of objects by holding down the Shift key while you drag diagonally to enclose each group of objects in a rectangle.

SIMM An acronym for Single In-line Memory Module, a circuit board that contains eight RAM chips. SIMMs attach to SIMM sockets on the computer's main circuit board. See also **random-access memory**.

size box A box on the bottom-right corner of some active windows. Dragging the size box resizes the window.

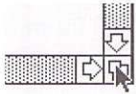

Small Computer System Interface (Abbreviated *SCSI*.) A specification of mechanical, electrical, and functional standards for connecting peripheral devices such as certain kinds of hard disks, printers, and optical disks to small computers. Macintosh computers use the SCSI interface for hard disks and other peripheral devices.

source The disk or folder that holds the original of a file to be copied or translated, as in *source disk*.

startup disk A disk with all the necessary program files—such as the Finder and System files contained in the System Folder—to set the computer into operation.

startup drive The disk drive from which you start your computer system.

Sticky Keys An Easy Access feature that lets you type combination keystrokes without actually pressing the keys simultaneously. Sticky Keys are especially helpful for users with impaired motor skills.

System file A file that Macintosh computers use to start up and to provide systemwide information. The System file must be in the System Folder.



System Folder A folder containing the software that Macintosh computers use to start up. A disk that contains a System Folder is a startup disk.

system software Software components that support application programs by managing system resources—such as memory—and input and output devices. Also known as the *operating system*.

T

TeachText A utility program on the *System Tools* disk that functions as a limited word-processing program.



terminator See **SCSI cable terminator**.

3.5-inch disk A flexible, plastic disk measuring 3.5 inches in diameter and having a rigid plastic jacket. On the Macintosh, 3.5-inch disks are the standard type of floppy disk used. These disks store 400K, 800K, or 1.4 MB of information, depending on the type of disk drive and formatting used. See also **kilobyte**, **megabyte**.

title bar The horizontal bar, at the top of a window, that shows the name of the window's contents. When the window is active, the title bar is highlighted with a series of horizontal lines.

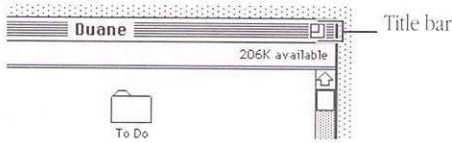

Trash An icon on the desktop that you use to discard documents, folders, and application programs. You can also drag disk icons into the Trash to eject disks.



U

unlock To remove the restriction on the use of a disk or a document so that it can once again be changed, deleted, or renamed. See also **lock**.

user group A computer club where computer users exchange tips and information.

user interface See **interface**.

utility programs Programs you use to perform special operations, such as installing or updating software, seeing a magnified version of the screen's contents, and so on.

V

version A number indicating the release edition of a particular piece of software.

video monitor A display device that can receive video signals by direct connection only, unlike a television set, which can receive broadcast signals. Sometimes simply called a *monitor*.

virus A malicious program that damages files. Virus programs can be spread through networks and bulletin board services as well as on disks. Virus-detection and elimination programs are available through dealers and user groups.

volume A general term referring to a storage device; a source of or a destination for information. Often used in reference to hard disks and file servers. A volume can be an entire disk or only part of a disk.

W, X, Y

window The area that displays information on the desktop; you create and view a document through a window. You can open or close a window, move it around on the desktop, and sometimes change its size, scroll through it, and edit its contents.

write To transfer information from the computer to a destination external to the computer (such as a disk drive, printer, or modem), or from the computer's processor to a destination external to the processor (such as main memory).

Z

zoom box A small box in the top-right corner of the title bar of some windows.

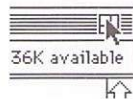

Clicking the zoom box expands the window to its maximum size; clicking it again returns the window to its original size.

Index

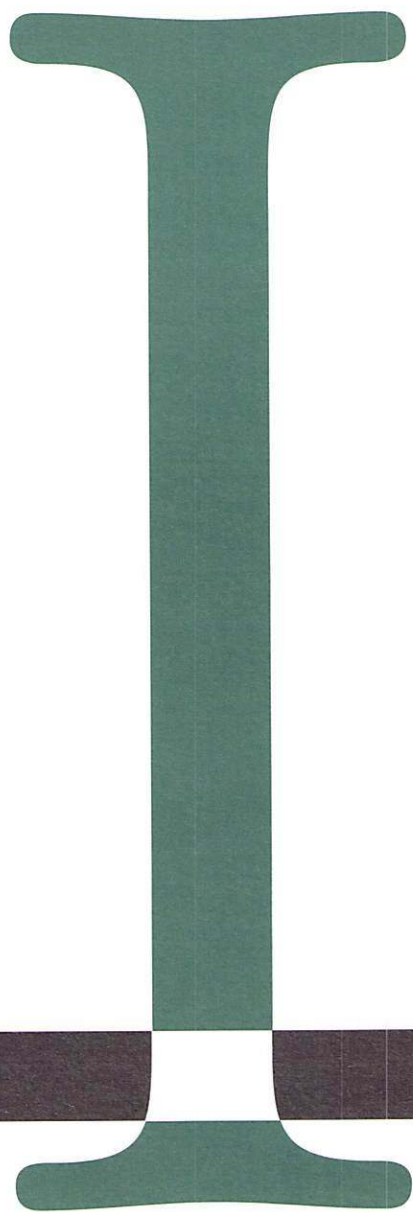

Numeric Entries

- 12-hour clock
 - setting and location 214, 215
- 24-hour clock
 - setting and location 214, 215
- 3.5 inch disks (MS-DOS). *See also* devices; disks
 - initializing 337
 - reading with Apple SuperDrive 336
- 32-Bit QuickDraw
 - installing 64
- 5.25 inch disks (MS-DOS). *See also* devices; disks
 - reading from an external floppy drive 339
- 720K
 - MS-DOS normal-density floppy disk size, initializing 339

A

- A/UX. *See also* alternative operating systems; Apple File Exchange
 - Function keys, use with 326
 - setting up a hard disk to run with 170
 - warnings about hard disks containing 48, 168, 171
- About command (Apple menu)
 - Apple File Exchange, investigating options 345
 - displaying information about application programs with 150, 153
 - Finder, verifying memory amount with 103
- access. *See also* security privileges, on a file server 200
- accessing. *See also* opening file servers
 - on AppleShare 196
 - private files on 200
 - menus 20, 21, 23, 24
- Access Privileges (desk accessory). *See also* file servers; networks
 - AppleShare file server and 187
 - protecting folder contents with 181
- access protection. *See* passwords; security
- activating. *See also* selecting windows 12
- active window 12
- acute accent (')
 - entering with Option-c 330
- ADB. *See* Apple Desktop Bus
- adding. *See also* connecting
 - desk accessories 253
 - devices 265–287
 - fonts 249
 - Macintosh to a network 183–193
- adjusting. *See* changing
- air circulation. *See also* maintenance; ventilation
 - importance for heat dispersion 293

- alarm
 - setting and turning off 218–220
 - Alarm Clock. *See also* desk accessories
 - desk accessory, setting alarm, date, and time with 216, 218–220
 - icon, on menu bar 221
 - turning off the alarm 221
 - alert
 - boxes, using 28
 - flashing, setting the 214
 - sound, setting the 213
 - time, setting with the Alarm Clock desk accessory 216
 - alignment. *See also* graphics; printing
 - of bit-mapped areas, with LaserWriter 119
 - allocating memory. *See* memory
 - alternative operating systems. *See also* A/UX; MS-DOS; ProDOS
 - converting files from 336–345
 - Special keys, use with 327
 - amplifier. *See also* devices; sound
 - attaching to the audio jack 276
 - APDA 355
 - Apple
 - service and support information 318
 - technical information available from 354
 - AppleCare Service Agreement
 - characteristics of 319
 - Apple Communications Library
 - description 355
 - Apple Desktop Bus (ADB)
 - devices, connecting 273–276
 - ports
 - connecting devices to 273
 - diagnosing input problems 306
 - power requirements 273
 - Apple Developer Programs
 - description 356
 - Apple Extended Keyboard
 - key descriptions (figure) 326
 - Apple File Exchange. *See also* networks
 - use with MS-DOS files and disks 336–345
 - Apple HD SC Setup program
 - using 168–170
 - Apple IIgs
 - sharing a hard disk with (partitioning) 170
 - Apple Keyboard
 - key descriptions (figure) 324
 - Apple menu. *See also* menus
 - About command
 - as clue to where you are 94
 - for application programs 20, 150, 153
 - About the Apple File Exchange command 345
 - About the Finder command, verifying memory amount with 103
 - Chooser desk accessory
 - 39–41
 - file server connection with 196
 - output devices, selecting 116
 - printers, designating in 116–118
 - printers, network setup 192
 - printers, setting up
 - background 130
 - printers, solving problems with 312
 - finding active programs 95
 - Find File desk accessory 144–146
 - General Control Panel
 - location in 36
 - Key Caps desk accessory 328, 329
 - Scrapbook desk accessory, editing operations in 91
 - top line of, as clue to where you are 94
- AppleShare. *See also* networks
 - driver, installing as preparation for networking 187
 - file server 196–200
 - file server, using MS-DOS files on 343
- AppleShare PC program
 - converting MS-DOS files with 343
- AppleTalk network 183–201. *See also* LocalTalk; networks
 - activating with the Chooser (figure) 41
 - connecting printers to 269
 - selecting devices on with the Chooser 39
 - zones, listed in the Chooser window (figure) 41
- Apple Technical Library
 - description 355
- application programs. *See also* desk accessories; software; system software
 - active, finding out which is 95
 - copying, as installation method 72

- creating new documents from within 74
 - displaying information about 153
 - ejecting disks from within 160
 - importance of keeping only one version on hard disks 315
 - installing 72
 - in use, effect on discarding icons 15
 - managing multiple 97
 - memory
 - changing allocation for 105
 - checking allocation for 104
 - open
 - at startup, specifying 66 (table), 98–100
 - finding out which are 95
 - opening 73, 76, 101
 - operations common to all 71–111
 - printing from 122, 194
 - quitting 74, 109
 - relationship with system software 48
 - returning to desktop from 96
 - starting 73, 76, 101
 - switching with MultiFinder 100
- arrow keys. *See also* keyboard
- alternative to mouse for pointer movement 323, 325, 327
 - primary use, in summary of special keys (figure) 42
- arrow(s)
- pointer as 2
 - scroll, displaying window contents with 16
- attaching. *See* connecting
- audio devices. *See also* devices; sound
- connecting to audio jack 276
- automatic repair. *See also* troubleshooting
- with Disk First Aid 297
- ## B
- background. *See also* MultiFinder
- editing desktop pattern 223, 242
 - printing
 - controlling with PrintMonitor program 131
 - turning on and off in the Chooser (figure) 41
 - using a print server with 195
- backing up. *See also* security; viruses
- data, by saving documents 84–93
 - date view useful for 150
 - devices for, SCSI tape drives as 266
 - disks 165, 175
 - documents, by copying individually 137
 - files 110
 - strategies for 317
- Backspace (Delete) key
- deleting selected text 33, 323
- barcode readers 273. *See also* Apple Desktop Bus devices; devices
- battery. *See also* maintenance
- clock, changing 300
- beep. *See also* sound
- changing type of sound 213
 - volume of sound 211
- Berkeley Macintosh User Group address 354
- binary translation
- Apple File Exchange use for 339
- bits 269
- blinking. *See also* Control Panel; customizing
- alarm icon in menu bar, meaning of 221
 - command, meaning of 22
 - menu item, changing speed of 225
 - question mark icon, meaning of 305
- BMUG
- See* Berkeley Macintosh Users Group
- bomb icon 309. *See also* troubleshooting
- boot. *See* startup
- Boston Computer Society address 354
- brightness control. *See also* monitors; screen saving
- adjusting 234
 - diagnosing monitor problems with 304
 - screen saving with 291
- bulletin boards. *See also* networks
- accessing with a modem 201
- ## C
- cables. *See also* devices
- daisy chaining SCSI devices with 267
 - handling precautions 290
 - LocalTalk network 185
- calendar icon
- changing date with 217

- canceling. *See also* deleting
 - background printing jobs 132
 - editing actions 83
- Caps Lock key
 - keyboard diagrams (figures) 322, 324, 326
- cards. *See also* devices
 - expansion, installing and use 281–285
- cassette tape icon (MacroMaker) 332
- CDEV (Control Panel devices)
 - as potential cause of software incompatibility 315
- CD-ROM drives. *See also* devices; disks
 - connecting 266
- cedilla (ç). *See also* characters
 - entering with Option-c 330
- changing. *See also* adding; deleting; installing
 - beep
 - type of sound 213
 - volume of sound 211
 - blinking
 - insertion point, speed 225
 - menu item, speed 225
 - Chooser settings 41
 - clock battery 300
 - Control Panel 38, 203–263
 - date 38, 217
 - desktop
 - appearance 221
 - patterns 238, 23, 242
 - disks
 - from the desktop 159
 - from within a program 160
 - documents, saving after 86
 - General Control Panel 37, 38
 - highlight color or gray shade 244
- icon
 - color or gray shade 244
 - name 29–34
 - MacroMaker scripts 335
 - memory allocation for a program 105
 - mouse operation 204–207
 - networks 190
 - pointer movement between multiple monitors 227
 - programs, in MultiFinder 100
 - RAM cache size 106
 - screen brightness 234
 - sound 211–214
 - speaker volume 38
 - startup disk 176
 - time of day 38, 215
 - windows 11
- characters. *See also* customizing; editing
 - deselecting 31
 - entering
 - international 330
 - optional 328
 - repeating, adjusting the rate of 209
 - manipulating (appendix) 321
- checking
 - Clipboard contents 78
 - installed system software 49
 - memory available 104
- Chooser desk accessory 39–41.
 - See also* desk accessories
- file server connection with 196
- output devices, selecting 116
- printers
 - designating in 116–118
 - network setup 192
 - solving problems with 312
- printing, setting up
 - background 130
- choosing. *See also* selecting
 - commands 7, 21
 - font name, for Key Caps display 330
 - printers 116–118
- circumflex (^). *See also* characters
 - entering with Option-i 330
- classes
 - Macintosh, where to find 354
- cleaning. *See also* maintenance
 - mouse 294, 306
 - system components 294–296
- Clear command (Edit menu). *See also* Cut command
 - deleting
 - selected text in an icon name with 33
 - text and images permanently 82
 - with Scrapbook, use of 93
- Clear key 323, 325, 327
- clearing. *See also* deleting
 - icons from the desktop 14
 - system memory 104
- clicking 4. *See also* double-clicking; mouse; selecting
 - double-clicking, description of 5
 - in scroll bar 19
 - selecting objects by 8
 - in window to make it active 13
- Clipboard. *See also* editing
 - checking contents of 78
 - copying text and images to 77
 - Cut command use of 33
 - deleting (cutting) text and images to 82
 - inserting text and images into a document from 78
- clock
 - battery, changing 300
 - icon, clicking to change time 215

- internal 214
- system, purpose of 300
- Close box
 - closing windows with 13 (figure) 9
- Close command (File menu)
 - closing windows with 13
- CloseView Control Panel 350, 351
- closing. *See also* opening windows 13
- cloverleaf. *See* Command key
- color. *See also* gray shade; monitors
 - desktop patterns, editing 224, 242
 - display of, designating 235
 - highlight, changing 244
 - how to use 235
 - icons
 - designating and viewing by color 244, 245
 - listing the contents of a folder by 150
 - images, enhancing with 32-Bit QuickDraw 64
 - numbers of 235
 - printing, installing drivers for 114
 - wheel dialog box 238, 240
- Color bar (Desktop Pattern area of General Control Panel) 242
- Color button (Monitors Control Panel) 237
- Color Control Panel
 - components of (figure) 235
- Color menu
 - changing icon colors with 244
- Command key
 - menu equivalent use of 22, 322, 324, 326
 - primary use, in summary of special keys (figure) 42
 - Sticky Keys combinations 347
- Command-C (Copy command, Edit menu) 78
- Command-D (Duplicate command, Edit menu) 138
- Command-E (Eject command, File menu) 159
- Command-I (Get Info command, File menu) 152
- Command-Q (Quit command, File menu) 74
- Command-S (Save command, File menu) 86
- Command-Shift-1
 - ejecting, floppy disks with 159, 308
- Command-Shift-2
 - ejecting, external floppy disks with 159, 308
- Command-Shift-Clear
 - turning Mouse Keys on and off with 349
- Command-V (Paste command, Edit menu) 79
- Command-X (Cut command, Edit menu) 82
- Command-Z (Undo command, Edit menu) 83
- commands. *See also* keyboard shortcuts, *specific command names*
 - choosing 7, 21
 - core, list of (figure) 20
 - creating macros for 331
 - dimmed, meaning of 22
 - dots following, meaning of 26
 - highlighted, meaning of 22
- initiated, blinking as indicator of 22
- keyboard equivalents,
 - displayed in menu 22
 - special keyboard keys for 42
- commercial information services
 - accessing with a modem 201
- communications. *See also*
 - AppleShare; networks link, establishing 271
 - programs, directing modem operation with 201
- compact Macintosh models
 - attaching additional monitors to 280
 - turning on 44
- computers
 - networks, using the Macintosh on 183–201
 - operation, problems 304
 - sharing
 - with hard disk partition 170
 - by use of a network 183
- configuration
 - hardware, recommended minimum 51
- connecting. *See also* adding; installing
 - Apple Desktop Bus (ADB) devices 273–276
 - audio devices 276
 - computers with a modem 201
 - keyboard 273
 - Macintosh to a network 183–193
 - modems 271
 - monitors 276–281
 - mouse 275
 - non-SCSI devices 269
 - printers 269, 271
 - SCSI devices 266

- Control key
 - generating optional characters with (figure) 329
 - primary use, in summary of special keys (figure) 42
 - Sticky Keys combinations 347
 - use similar to Command key (figure) 324, 326
- Control Panel desk accessory 203–263. *See also* customizing; desk accessories
- CloseView Control Panel 351
- Color Control Panel, components of (figure) 235
- customizing the work space with 203–263
- General Control Panel 214
 - changing, blinking of insertion point, menu item 225, 226
 - changing, desktop pattern 223–224
 - changing, desktop pattern in color or gray shades 242–244
 - changing, networks 190
 - changing, RAM cache 106
 - changing, sections and settings 37, 38, 203–263
 - changing, speaker volume 212
 - description and use (figure) 35–38
 - designating a startup disk from 177
 - opening 36
 - position in startup scanning order 176
 - setting date and time 214
 - settings that may be adjusted, list of 36
- Keyboard Control Panel, adjusting character repetition with 208–210
- Monitors Control Panel
 - specifying main monitor with 231–233
 - specifying number of colors or gray shades with 235
 - specifying relative monitors position with 227
- Mouse Control Panel 204, 206
- Network Control Panel, changing networks with 190–191
- Sound Control Panel
 - adjusting sound volume with 211
 - setting alert sound with 213
- Control Panel devices (CDEV)
 - as potential cause of software incompatibility 315
- conventions
 - document version naming 88
- converting
 - Apple II files with Apple File Exchange 345
 - Macintosh files into MS-DOS format 339
 - MS-DOS files 339, 345
- coprocessor cards
 - installing on Macintosh II models 281
- Copy button (Font/DA Mover) 256
- Copy command (Edit menu)
 - application programs use of (figure) 20
 - copying text and images 77, 79
 - Scrapbook use of 93
- copying. *See also* Clipboard; editing; Scrapbook desk accessory
 - application programs, as installation method 72
 - desk accessories, from one file to another 258
 - disks, as backup method 165
 - documents
 - between disks 137, 90
 - on the same disk 88, 138
 - files
 - as backup procedure 110, 175
 - from a file server 200
 - fonts, from one file to another 250
 - images 77, 79, 91
 - network software onto a startup disk 188
 - selected graphics or text, effect on contents of Clipboard 77
 - text
 - between application programs 91
 - between documents 78, 79
- correcting. *See also* changing problems, strategies for 313
 - typing errors 85
- crash. *See also* maintenance; security
 - system, strategies for handling 309
- creating. *See also* changing; editing
 - documents
 - and saving them 85
 - hierarchy of 143
 - multiple versions of 88
 - procedures for 74
 - files of desk accessories and fonts 260

- folders 141–143
- log, translated files 344
- macros 331–335
- startup disks 60–63
- systems
 - customized 56–60
 - small 62
 - standard 52
- crosshair pointer. *See* pointers
- current (electric). *See* power
- cursor. *See also* pointers
 - movement, arrow keys as
 - mouse alternative 42
- customizing
 - hardware by adding devices
 - 265–287
 - working environment
 - 203–263
- Cut command (Edit menu). *See also* editing; Paste command
 - application programs use of
 - (figure) 20
 - compared with Clear
 - command 82
 - deleting
 - selected text in an icon
 - name with 33
 - text and images without
 - losing them 82
 - Scrapbook use of 93
- cut sheet feeder use. *See also* printers
 - setting for ImageWriter 121

D

- daisy-chaining. *See also* devices
 - ADB devices 273, 275
 - description 266
 - SCSI devices 267

- data. *See also* application programs; editing; hierarchical file system (HFS); translating
 - avoiding loss 302
 - backing up, by saving
 - documents 84–93
 - deleting 161, 168, 174
 - preventing damage to 302
 - sending to other computers by
 - modems 201
- date. *See also* time
 - listing the contents of a folder
 - by 150
 - setting 38, 221, 217
- DCA-RFT/MacWrite translator file. *See also* files
 - converting MacWrite and MS-DOS files 339
- delaying key repeat interval 210
- Delete key
 - compared with, Clear key 327
 - correcting typing errors with
 - 85
 - deleting
 - characters to the left of
 - insertion point with
 - 325, 327
 - selected text in an icon
 - name with 33
 - text and images
 - permanently 82
 - primary use, in summary of
 - special keys (figure) 42
- deleting. *See also* Clear command; Cut command; erasing; removing
 - desk accessories 258
 - files 161, 168, 174
 - fonts 251
 - from the Scrapbook 93
 - icons 14

- images 82
 - selected items 77
 - text
 - in an icon name 33
 - in a document 82
- deselecting. *See also* selecting
 - active translators 341
 - characters 31
 - icons 30, 33
 - selected objects 8
 - text 31
- designating
 - icon color 244
 - main monitor 231–233
 - printers 40, 192
 - zones 192
- designing expansion cards 355
- desktop
 - changing 221–234
 - pattern 38, 223, 242
 - clearing icons from 14
 - components of (figure) 9
 - editing, basic procedures 29
 - moving around the 9
 - opening
 - documents from 76
 - programs from using
 - MultiFinder 101
 - pattern 223, 242
 - printing from 123
 - putting away items on the 149
 - rebuilding, avoiding problems
 - by 317
 - renaming
 - disks from the 164
 - documents from the 139
 - returning to 96
- desk accessories. *See also* Apple menu; application programs; fonts; software; system software; *specific desk accessories*

- creating file of 260–263
- description 35
- incompatible, as potential cause of system crash 310
- list of required and optional 63
- managing 253–263
- moving 246
- removing from System Folder 62
- sources of 246
- specifying for startup (table) 66
- switching with MultiFinder 100
- destination disk
 - specifying in Apple File Exchange procedures 340
- destroying. *See* deleting
- detecting viruses 302
- devices. *See also* Apple Desktop Bus (ADB) devices; cables; disks; drivers; modems; monitors; output devices; printers; resources; storage devices
 - adding 265–287
 - connecting
 - non-SCSI 269
 - SCSI 266
 - selecting 40
- diagnosing problems. *See also* troubleshooting
 - disk 297
 - strategies for
 - general 313
 - virus 302
- dialog boxes
 - alert boxes as a type of 28
 - description and use (figure) 26
 - pop-up menu use in (figure) 24
- dimmed commands
 - meaning of 22
- directories. *See also* files; folders; hierarchical file system (HFS)
 - obtaining information about 150
 - printing 124
- directory dialog box
 - for saving files (figure) 84
 - moving around folder hierarchy with 146
 - using a 26
- discarding. *See also* deleting icons 14
- disconnecting. *See also* connecting from a file server volume 199
- Disk First Aid
 - repairing disks with 297
- disk(s). *See also* floppy disks; hard disks; high-density disks
 - backing up 165, 175
 - creating startup 60–63
 - drives
 - installing system software on a one-drive system 60
 - managing 155–181
 - port, connecting floppy disk drives to 273
 - ejecting 159, 160
 - erasing 161, 163, 168, 174
 - exchanging, with MS-DOS computers 336–345
 - 5.25-inch disks 339
 - floppy
 - characteristics and use 156–166
 - creating small systems on 62
 - installing system software on 60
 - fragmentation, reducing 315
- hard
 - characteristics and use 166–175
 - initializing 168–170
 - partitioning 170
 - renaming 175
- initializing 161, 168
- installing fonts on different 247
- locking, to protect information 179
- managing 155–181
- moving
 - desk accessories between 254, 258
 - fonts between 250
- naming 29, 162, 164, 168
- partitioning, hard 170
- problems, causes and suggested solutions 307
- repairing 297
- startup, designating a 176
- testing 297
- 3.5-inch 288, 289
- displaying
 - background patterns, available 223
 - character sets for fonts 330
 - document contents 5
 - files, information about 150
 - folders, information about 150
 - icon contents 5
 - information, with Get Info command 151
 - messages on the screen 26
 - window contents by the screenful 19
- Document Content Architecture. *See* DCA-RFT
- documents. *See also* application programs; editing; fonts; text

- changing, names 29
 - copying
 - between disks 90, 137
 - on the same disk 138
 - text and images between 79
 - to different folders on the same disk 88
 - creating 74
 - hierarchy of 143
 - multiple versions of 88
 - displaying the contents of 5
 - editing 76–83
 - finding 144
 - handling, Macintosh tools for 136–153
 - icons, double-clicking, to start an application program 74
 - moving 136
 - naming
 - correcting typing errors in 85
 - in application programs that automatically save 86
 - new 85
 - version conventions 88
 - opening
 - from the desktop 76
 - from within an application program 75
 - in a directory dialog box 27
 - documents (*continued*)
 - organizing 135–153
 - pasting, text and images into 78
 - placing in folders 142
 - printing 113–133
 - failure, causes and suggested solutions 312
 - on the network 194
 - renaming 139
 - when saving 87
 - without retaining a version 88
 - replacing, Alert box verification 89
 - saving 84–93
 - specifying for startup 66, 98–100
 - version handling 88
 - dotted rectangle
 - significance of 7
 - double-clicking. *See also* selecting icons, to start an application program 73, 74
 - saving new desktop patterns with 224
 - speed, setting 206
 - windows, to make them active 13
 - downloadable fonts. *See also* characters; fonts; printing description 119
 - dragging. *See also* moving
 - correcting typing errors with 85
 - documents 136
 - ejecting floppy disks by
 - dragging to Trash icon 15
 - objects 5
 - pointer
 - to choose a submenu 23
 - in menus 22
 - resizing windows with 11
 - scroll box 18
 - selecting part of an icon's name by 30
 - windows 10
 - drawing. *See also* graphics
 - with the mouse, adjusting mouse tracking for 205
 - drivers. *See also* devices
 - adding by copying into System Folder 50
 - finding a list of system-supplied 52
 - installing, as preparation for networking 187
 - printer, installing 114
 - programming, where to find help with 355
 - removing from System Folder 62
 - system resources in the System Folder (figure) 49
 - Duplicate command (File menu)
 - copying documents with 138
 - duplicating. *See also* copying files 138
- ## E
- Easy Access program
 - characteristics and use 347–349
 - Easy Install option (Installer program) 52–55
 - editing. *See also* adding; Clipboard; copying; creating; deleting; Scrapbook desk accessory
 - canceling most recent action 83
 - desktop
 - basic procedures 29
 - changing document names with 139
 - patterns 223, 242
 - renaming disks 164
 - documents 76–83
 - on the file server 200

- reversing Undo command 83
- Scrapbook contents 93
- text 77–83
 - actions common to all application programs 76–83
 - selecting while 7
- Edit menu
 - application programs use of (figure) 20
- Clear command
 - deleting selected text in an icon name with 33
 - deleting text and images permanently 82
 - Scrapbook use of 93
- Copy command
 - copying text and images with 77, 79
 - Scrapbook use of 93
- Cut command
 - compared with Clear command 82
 - deleting selected text in an icon name with 33
 - deleting text and images without losing them 82
 - Scrapbook use of 93
- Paste command
 - copying text and images with 81
 - inserting text and images into a document from 78
 - Scrapbook use of 93
- Show Clipboard command 78
- Undo command, canceling editing actions with 83
- Eject command (File menu)
 - ejecting floppy disks with 159
- ejecting floppy disks 159–160
 - after display of “sad Macintosh” icon 305
 - failure, causes and suggested solutions 308
 - from within a program 160
- electrical safety. *See also* maintenance; troubleshooting
 - precautions when setting up 290
- Empty Trash command (Special menu)
 - erasing icon contents with 14
- ending
 - macro recording 334
 - work sessions, good methods for 109–111
- enlarging. *See also* resizing
 - paper size, implications of 119
 - windows 11
- entering. *See also* characters
 - optional characters 328
- Enter key
 - initiating actions with 324, 325, 327
 - primary use, in summary of special keys (figure) 42
- environment
 - clues to finding out where you are 94
- Erase Disk command (File menu, Apple File Exchange), erasing non-Macintosh disks 344 (Special menu), erasing disks with 163, 174
 - erasing. *See also* deleting; editing; removing
 - disks
 - floppy 161
 - hard 168, 174
 - non-Macintosh 344
 - with Erase Disk command 163
 - macros (figure) 333
 - error messages 26. *See also* problems
 - errors
 - See* changing; correcting; editing; mistakes
 - Escape
 - See* Esc key
 - Esc key
 - primary use, in summary of special keys (figure) 42
 - program-dependent function key 324, 327
 - Ethernet
 - connecting Macintosh to 183
 - installing 187
 - everyone
 - file server access privilege, description 200
 - exchanging
 - disks and files, with MS-DOS computers 336–345
 - files, reading MS-DOS 3.5-inch disks on SuperDrive 157
 - memory modules, as expansion method 287
 - expansion
 - cards
 - designing 355
 - installing 281–285
 - slots, NuBus in Macintosh II models 281, 282
 - extending
 - selected text 31
 - external floppy disk drives
 - ejecting floppy disks from 159
 - reading MS-DOS disks with 5.25-inch drives 339

F

File menu

- application programs use of (figure) 20
- Close Command, closing windows with 13
- Duplicate command, copying documents with 138
- Eject command, ejecting floppy disks with 159
- Get Info command
 - changing memory allocation for a program with 105
 - displaying information about icons with 151
 - locking application programs and documents with 152
- New command, creating new documents with 74
- New Folder command, creating and naming folders with 141
- Open command
 - opening icons with 10
 - starting programs with 74
- Page Setup command, options, choosing 118–120
- Print command
 - application programs use of 194
 - options 121
 - printing on a network 194
- Print Directory command 125
- Put Away command 149
- Quit command 74, 109
- Save As command, saving revised documents, by changing the document name 87
- Save command 85, 86

- file(s). *See also* application programs; documents; folders; hierarchical file system (HFS); networks
 - backing up 110, 150
 - copying desk accessories between 258
 - exchanging
 - reading MS-DOS 3.5-inch disks with SuperDrive 157
 - with MS-DOS computers 336–345
 - font
 - copying fonts from one file to another 250
 - using 247
 - managing, methods for 84–93
 - naming 85, 86, 88
 - opening in a directory dialog box 27
 - organizing, with View menu 150
 - printing a directory of 124
 - private, creating on a file server 200
 - receiving across a network 201
 - renaming 139
 - saving 84–93
 - disk problems, causes and suggested solutions 307
 - in application programs 84–93
 - Scrapbook, handling 93
 - sending across a network 201
 - servers
 - selecting with the Chooser 39
 - using 196–200
 - sharing across a network 183
 - translating
 - creating a log 344
 - non-Macintosh files 339
 - versions 88
- file system

- managing documents with 140–153
- Finder. *See also* MultiFinder; system software
 - obtaining information about 103
 - specifying items to be opened under 66
- Find File desk accessory. *See also* desk accessories
 - Apple Menu, using 144–146
- finding. *See also* organizing documents 144
 - files, limiting search 146
 - folders 144
- 5.25 inch disks (MS-DOS). *See also* devices; disks
 - reading from an external floppy drive 339
- flipped image
 - LaserWriter Page Setup option 119
- floppy disks. *See also* devices; disks
 - capacities 156
 - characteristics and use 156–166
 - creating small systems on 62
 - drives
 - connecting 273
 - protecting during transport 292
 - ejecting 15, 159
 - 5.25-inch 339
 - handling precautions 292
 - installing system software on 60
 - locking 179
 - managing 156–166
 - MS-DOS format, initializing
 - 3.5-inch 337
 - repairing 297
 - testing 297

- folders. *See also* documents; files; hierarchical file system (HFS)
 - contents, viewing 150
 - moving through levels of 24
 - opening in a directory dialog box 27
 - organizing documents with 140–149
 - protecting the contents of 181
 - Font/DA Mover. *See also* desk accessories; fonts; system software
 - creating files of fonts and desk accessories 260
 - installing, desk accessories with 189, 253
 - moving fonts and desk accessories with 246–263
 - removing
 - desk accessories with 258
 - fonts with 251, 252
 - window layout description (figure) 246
 - fonts. *See also* desk accessories; documents; editing; text downloadable 119
 - managing 246–263
 - removing, from System Folder 62
 - substitution, LaserWriter Page Setup option 119
 - formatted disk. *See* initializing
 - fragmentation
 - disk, reducing 315
 - memory, handling 104
 - freezing pointer
 - causes and suggested solutions 311
 - Function keys
 - Apple Extended Keyboard, alternative operating system use of 327
 - creating macros for, using MacroMaker 331
 - primary use, in summary of special keys (figure) 42
- G**
- General Control Panel. *See* Control Panel, General
 - Get Info command (File menu)
 - changing memory allocation with 105
 - displaying information about icons with 150, 151
 - locking application programs and documents with 152
 - global macros 335. *See also* MacroMaker
 - glossary
 - term and concept definitions 357–371
 - graphics. *See also* Apple Desktop Bus (ADB); images; text cards, NuBus, installing 281
 - tablets
 - adjusting mouse tracking for operation with 205
 - connecting 273
 - graphic smoothing
 - LaserWriter enhancement 119
 - grave accent (`)
 - entering with Option-` 330
 - grayed-out commands
 - meaning of 22
 - gray shades. *See also* color; monitors
 - changing 242, 244
 - specifying the number of 235
 - viewing icons by 245
 - grounding. *See also* maintenance electrical, importance of 290
 - group. *See also* security
 - file server access privilege, description 200
 - guidelines
 - programming and user interface design for the Macintosh, where to find 355
- H**
- handicapped
 - physically, Easy Access features for 346–349
 - visually, aids for 350–352
 - “happy Macintosh” icon
 - meaning of 305
 - hard disks. *See also* devices; disks
 - connecting non-SCSI 273
 - connecting SCSI 266–269
 - drives 266
 - managing 166–175
 - problems, diagnosing 309
 - repairing 297
 - testing 297
 - hardware. *See also* devices; software
 - design, finding information on Macintosh 355
 - developers, assistance for 356
 - HD SC Setup program
 - testing SCSI hard disks with 299
 - headphones. *See also* Apple Desktop Bus (ADB)
 - devices; sound
 - connecting to the Macintosh 276
 - help
 - Macintosh organizations, user groups, and literature 354

- technical information 354
 - HFS.
 - See* hierarchical file system
 - hierarchical file system (HFS).
 - See also* directories; files; folders; organizing
 - using 140–149
 - high-density disks. *See also* devices; disks
 - characteristics and use 157
 - highlighted commands
 - meaning of 22
 - highlighting. *See also* selecting color
 - brightness of 240
 - changing 244
 - objects 5
 - removing 8
 - hooking up. *See* connecting
 - horizontal tab character.
 - See* characters
 - humidity. *See also* maintenance
 - optimal for Macintosh operation 293
 - HyperCard
 - automatic save feature of 86
- I, J
- I-beam pointer. *See also* pointers
 - description 30
 - inserting text with 34
 - icons. *See also* user interface
 - Apple Desktop Bus 274
 - application program, starting by double-clicking 73
 - bomb, causes and suggested solutions 309
 - color 239, 244
 - deselecting 30, 33
 - dimmed, meaning of 9
 - discarding 14
 - disk
 - as potential cause of software incompatibility 315
 - initializing disks
 - floppy 161
 - hard 168
 - MS-DOS 3.5 inch 337
 - normal-density, in MS-DOS format 339
 - initiating. *See* starting
 - input devices. *See also* devices
 - connecting 273
 - inserting
 - floppy disks, in a disk drive 158
 - text, in an icon name 34
 - and images, into a document 78
 - insertion point. *See also* pointers
 - arrow keys as alternative to mouse for moving 42
 - changing the blinking speed 225
 - deleting character to the left of with Delete key 325
 - description 29
 - Installer program
 - Customize options 56–60
 - Easy Install option 52–55
 - options for 51
 - installing. *See also* connecting; devices; maintenance; software
 - 32-Bit QuickDraw 64
 - application programs 72
 - CloseView 350
 - customized systems 56–60
 - desk accessories 253
 - expansion cards, on Macintosh II models 281
 - fonts 247
 - MacroMaker 331
 - memory cache cards 286
 - disk
 - with blinking question mark 305
 - with X character 305
 - disk drive port 272
 - displaying the contents of 5
 - examples of (figure) 1
 - listing the contents of a folder by 150
 - modem (figure) 272
 - name
 - changing 29–34
 - deleting selected text in 33
 - inserting text in 34
 - selecting text in 29
 - opening 9
 - retrieving from the Trash 15
 - selecting 6
 - color or gray shade for 235
 - multiple icons 7
 - viewing by color 245
- images. *See also* graphics
 - copying 77, 79, 91
 - deleting 82
 - inserting, from Clipboard into a document 78
 - pasting, into a document 78
 - saving, Scrapbook desk
 - accessory use for 91
- ImageWriter printers. *See also* devices; LaserWriter printers; printers
 - background printing not available on 130
 - choosing 118
 - connecting to 269
 - network use of 192
 - printing options for 120, 121
 - problems, causes and suggested solutions 312
- INIT files

- network software 188
- NuBus cards, procedures and ventilation warnings 282
- printer drivers 114
- system software 51–56
 - on floppy disks 60
 - insurance. *See also* security
 - saving documents as 84–93
- interface
 - NuBus, description 281
- interference. *See also* maintenance
 - radio and television 293
- international language characters.
See also characters
- typing 330
- internet. *See also* networks; zones
 - connecting multiple networks into 192
- inverted image
 - LaserWriter page setup option 119

K

- keyboard. *See also* Apple Desktop Bus (ADB) devices; Control Panel
 - adjusting character repetition 209
 - connecting 273
 - Control Panel, changing keyboard parameters with 208–210
 - diagnosing cable problems 306
 - equivalents, for commands, displayed in menu 22
 - handicapped assistance 347
 - handling spills 291
 - layouts and character sets 321–330

- Macintosh Plus, connecting to the Macintosh 275
- one-handed use 347
- problems, diagnosing 306
- shortcuts
 - Copy command (Command-C) 78
 - Get Info command (Command-I) 152
 - Duplicate command (Command-D) 138
 - New Folder command (Command-N) 141
 - Paste command (Command-V) 79
 - Print command (Command-P) 122
 - printing with Return key 123
 - Quit command (Command-Q) 74
 - Return key, shortcut for Save button in Save dialog box 87
 - Save command (Command-S) 86
 - Undo command (Command-Z) 83
 - special keys, using (figure) 42
- keys. *See also specific keys*
 - arrow, alternative to mouse for pointer movement 323, 325
 - Mouse Keys 348–349
 - repeating by holding down 209
- Key Caps desk accessory
 - using 328

L

- LAN (local area network).
See LocalTalk; networks
- languages
 - entering international characters 330
- LaserWriter printers. *See also* devices, ImageWriter printers; printers
 - connecting 269
 - network use of 192
 - Page Setup options for (figure) 119
 - problems, causes and suggested solutions 312
- light pens. *See also* Apple Desktop Bus (ADB)
 - connecting 273
- lights
 - locking key indicators, (figure) 42
- linking. *See* connecting list
 - selecting items in a 7, 8
- loading. *See also* installing; starting
 - macros (figure) 333
- local area network (LAN).
See LocalTalk; networks
- LocalTalk. *See also* AppleTalk; networks
 - connecting to 184–186
 - description
 - as an AppleTalk network type 183
 - as a work group network 269
- locating. *See* finding
- location
 - clues to 94
- locking (and unlocking). *See also* protecting; security

- application programs, with
 - Get Info command 152, 180
- disks
 - as cause of inability to save to disk 307
 - to protect information 179
- documents
 - effect on discarding icons 15
 - with Get Info command 152, 180
 - implications of 179
- log
 - translated files, creating 344

M

- Macintosh
 - expanding the system 265–287
 - format, converting non-Macintosh files and disks to 345
 - operations, description of standard 1–45
 - ready to run, how to recognize 49
 - setting up the system 47–69
 - shutting down 110
 - startup, specifying items to automatically open on 65–69
 - technical help, where to find 354
 - turning on and off 43–45
 - user groups, names and addresses 354
- MacroMaker
 - command files, creating and using 331–335
- macros. *See also* customizing
 - creating and using 331–335

- MacWrite format
 - converting to and from MS-DOS 339
- magnetic tape. *See also* devices
 - connecting to the Macintosh 266
- magnification
 - screen, increasing and decreasing with CloseView 352
- maintenance. *See also* security
 - avoiding trouble, positioning of monitors 281
 - maintaining a safe and reliable operating environment 289–319
 - managing. *See also* maintenance; organizing
 - application programs 71–111
 - desk accessories 253–263
 - disks and disk drives 155–181
 - files 84–93
 - fonts 246–263
 - multiple application programs 97
 - printing jobs
 - with a spooler 195
 - with PrintMonitor 131–133
 - system memory 102
 - work environment
 - backing up files 110
 - maintaining a safe and reliable operating environment 289–319
- manipulating
 - mouse, Mouse Keys as alternative to 348
- manual paper feed. *See also* printing
 - handling with PrintMonitor 132
- mathematical symbols
 - Numeric keys used for 325

- memory. *See also* devices
 - allocating for programs 105
 - cache cards, installing 286
 - cards, installing on a Macintosh II–family computer 281
 - expanding on the main circuit board 287
 - fragmentation, handling 104
 - installing 287
 - insufficient
 - MultiFinder alert that reports 102
 - suggested solutions 314
 - MultiFinder
 - checking the amount available 104
 - RAM cache, adjusting for efficient use 106
 - requirements 97, 103
 - system
 - clearing 104
 - managing 102
 - reserving for additional monitors 277
 - verifying the amount in your system 103
- menu bar
 - clues to finding out where you are (figure) 94
 - using 20–21
- menus. *See also* user interface
 - accessing 20–21
 - pop-up 24
 - pull-down 21
 - application programs use of (figure) 20
 - choosing commands from 7, 21
 - commands, avoid using in global macros 335
 - in dialog boxes, recognizing 26

- submenus, using 23
- messages 26. *See also* problems; troubleshooting
- microprocessor
 - exchanging signals with 281
- mistakes. *See also* problems
 - strategies for correcting problems 313
 - typing, correcting 85
- modem port
 - connecting printers to 269
 - use and advantages 271
- modems. *See also* devices; networks
 - connecting 201, 271
- modifier keys. *See also* keyboards
 - entering optional characters with 328
 - including in a macro 334
- modifying. *See* changing
- monitors. *See also* Control Panel; devices; graphics; video
 - adding additional 276
 - adjusting the brightness of 234
 - connecting to
 - compact Macintosh models 280
 - video cards 279
 - Control Panel, changing
 - monitor parameters with 227–245
 - maintenance of 291, 293
 - multiple
 - avoiding interference among 281
 - changing pointer movement between 227
 - designating the main monitor 231–233
 - indicating relative positions of 227
 - specifying color characteristics of 237
- mouse. *See also* Apple Desktop Bus (ADB); pointers
 - arrow keys as alternative for moving the mouse 42, 323
 - button
 - description of 2
 - double-clicking speed 206
 - changing mouse operation 204–207
 - cleaning the 294
 - Control Panel, changing
 - mouse operaton with 204–207
 - Macintosh Plus, connecting to the Macintosh 275
 - Mouse Keys, as alternative to 348
 - moving (figure) 2
 - picking up, effect on pointer 4
 - pointer
 - changing mouse movement relationship 204
 - moving mouse relative to 2
 - picking up mouse, effect on pointer 4
 - port
 - connecting mouse to Apple Desktop Bus (ADB) port 273
 - Macintosh Plus different from the Apple Desktop Bus (ADB) port 275
 - problems, diagnosing 306
 - tracking, options for 204
- Mouse Keys 348
- moving. *See also* dragging; shift-clicking
 - around the
 - desktop 9
 - folder hierarchy 146
 - desk accessories 246
 - documents 136, 142
 - folders 143
 - fonts 246
 - insertion point
 - horizontally, with Tab key 327
 - to the beginning of the next line with Return key 325
 - objects on the screen, by dragging 5
 - pointer (figure) 2
 - to a new folder level 148
 - windows 10, 12
 - MS-DOS. *See also* alternative operating systems
 - 3.5-inch disks
 - reading on the SuperDrive 157, 336
 - converting files
 - on a file server 343
 - to and from MacWrite format 339
- MultiFinder
 - capabilities 97
 - clues to finding out where you are 94
 - copying between application programs 80
 - installing
 - desk accessories 257
 - fonts 250
 - memory requirements and availability 103, 104
 - pointer freezing, possible cause 311
 - printing from the background 41, 130
 - RAM cache, adjusting for efficient MultiFinder use 106

- required for
 - printing from the background 41, 130
 - running multiple applications 97, 101
 - starting up with multiple open documents 68
- specifying items to be opening under 66
- turning on and off 98–100
- multiple application programs managing, with MultiFinder 97

N

- naming. *See also* renaming
 - disks 162, 168
 - documents 85
 - folders 141
 - icons 29
- nesting. *See also* hierarchical file system (HFS); organizing
 - folders 143
 - networks 183–201. *See also* AppleShare; communications; modems
 - AppleTalk, selecting devices with the Chooser 39
 - Control Panel, changing networks with 190
 - devices, selecting with the Chooser 40
 - EtherTalk cards, installing 187
 - files, sharing on 196
 - interface cards, installing 187, 281
 - LocalTalk 185
 - printers
 - connecting to 269

- print spoolers on 195
- selecting within zones 40, 117
- specifying with the Chooser 193
- software, installing 187, 188
- virus prevention when using 303
- New command (File menu)
 - creating new documents with 74
- New Folder command (File menu)
 - creating and naming folders with 141
- NuBus. *See also* hardware cards, installing 282–285
- numeric keypad
 - keyboard descriptions 324, 325, 327
 - Mouse Keys defined on 348

O

- objects
 - manipulating 5
 - selecting multiple objects in one area 7
 - separate areas 8
- office filing system
 - Macintosh metaphor, components of 135
- Open command (File menu)
 - dialog box, (figure) 26
 - opening icons with 10
 - starting programs with 74
- opening. *See also* closing; starting application program(s)
 - icons 73
 - with MultiFinder 101
- Chooser 39
- documents 75, 76

- General Control Panel 36
- icons 9
 - with Open command in File menu 10
 - on startup, specifying 65–69
- menus 21
- pop-up menus 24
- submenus 23
- windows, by double-clicking 5
- operating systems. *See also* alternative operating systems
 - multiple, running on the Macintosh 170
- operations
 - initiating with the mouse 2, 3
 - standard Macintosh 1–45
- Option key
 - primary use, in summary of special keys (figure) 42
 - special characters
 - Chicago font (figure) 329
 - producing 322, 324, 328
 - starting Font/DA Mover with 257
 - Sticky Keys combinations 347
 - typing accented characters with 330
- Option-`
 - grave accent, entering with 330
- Option-c
 - cedilla (ç), entering with 330
- Option-Command-Down Arrow
 - decreasing screen magnification with 352
- Option-Command-Up Arrow
 - increasing screen magnification with 352
- Option-Command-X
 - turning screen magnification on and off with 352

- Option-e
 - acute accent, entering with 330
- Option-i
 - circumflex (^), entering with 330
- Option-Shift key combination
 - entering optional characters with 328
 - special characters produced in Chicago font (figure) 329
- Option-u
 - umlaut (¨), entering with 330
- optional characters. *See also* characters
 - entering 328
- organizing. *See also* hierarchical file system (HFS); managing
 - documents 135–153
 - files
 - by icon color 245
 - with View menu 150
- outline
 - of object, significance of 5
- output devices. *See also* devices; printers
 - selecting 116
- overheating. *See also* maintenance precautions on 293
- overwriting. *See also* replacing; saving
 - documents 86, 89
 - selected text in an icon name 32
- owner
 - file server access privilege, description 200
- P
 - Page Setup command (File menu)
 - choosing options 118–120
 - paper. *See also* printing
 - clip, as a hardware troubleshooting tool 308
 - positioning, LaserWriter page setup options for 119
 - size, ImageWriter LQ options 120
 - supply, monitoring the 132
 - partitioning
 - hard disks 170
 - passwords. *See also* access protection; security
 - entering in AppleShare 198
 - Paste command (Edit menu)
 - application programs use of (figure) 20
 - copying text and images with 81
 - inserting text and images into a document from 78
 - Scrapbook use of 93
 - pasting. *See* Paste command
 - pattern (desktop). *See also* customizing
 - changing
 - bit pattern 223
 - colors and gray shades 242 (figure) 38
 - displaying available 223
 - personalizing. *See* customizing
 - pixels
 - background, editing the color of 243
 - description 224
 - playing
 - macros (figure) 333
- pointers
 - arrow 2
 - crosshair, use in changing Control Panel parameters (figures) 209–245
 - diagnosing problems 306, 311
 - dragging
 - to choose a command 22
 - to open a submenu 23
 - freezing, causes and suggested solutions 306, 311
 - I-beam
 - description 32
 - inserting text with 34
 - manipulating pointers with Mouse Keys 348
 - movement
 - between monitors, changing 227
 - changing the speed of 204
 - picking up mouse, effect on 4
 - wristwatch, indicator of save operation 86
- pointing
 - description of 3
- pop-up menus. *See also* menus
 - moving to a new folder level with 148
 - opening and using 24
 - seeing items that extend up from the title 25
- ports. *See also* Apple Desktop Bus (ADB); devices
 - modem 269, 271
 - non-SCSI, how to recognize 269
 - printer 184, 269, 271
 - SCSI description 266
- positioning
 - monitors 281

- power (electric). *See also*
 - installing; maintenance
 - consumption, NuBus cards 283
 - limits, NuBus cards 283
 - requirements 273, 283
 - switch, location of on different models 43
- powering down. *See also* shutting down
 - effect on Trash 14
- Power On key
 - Macintosh II model, turning on computer with 45
 - primary use, in summary of special keys (figure) 42
 - starting system with 324, 327
- precautions. *See also*
 - maintenance; managing; problems; troubleshooting
 - electrical 290
 - floppy disks 292
 - power requirements, NuBus cards 283
 - system upgrade, importance of 310
- preventing virus damage 302
- Print command (File menu)
 - application programs use of 194
 - options 121
 - printing on a network 194
- Print Directory command (File menu) 124–125
 - printing file directory for open window 125
- printers. *See also* devices; ImageWriter printers; LaserWriter printers
 - choosing 40, 116, 193
 - color, installing drivers for 114
 - connecting to the Macintosh 266, 269
 - drivers
 - installing 114, 187
 - supplied with system
 - software (figure) 114
 - network use of 187, 192, 193, 194
 - Page Setup options 118–120
 - port
 - connecting printers to 269, 271
 - connecting to a LocalTalk network through the 184
 - print
 - area, implications of large 119
 - quality setting for ImageWriter 121
 - server description 195
 - problems, causes and suggested solutions 312
 - sharing by use of a network 183
- printing. *See also* documents
 - background printing
 - procedures for 130
 - turning on and off (figure) 41
 - direction of, setting for ImageWriter 121
 - directories 124
 - documents 113–133
 - on a network printer 194
 - keyboard shortcut, Command-P 122
 - monitoring the status of 132
 - options 122
 - problems, causes and suggested solutions 312
 - time, setting the 132
- PrintMonitor. *See also* MultiFinder
 - using 131–133
- print server 195
- priority
 - modem port compared with the printer port 271
 - SCSI devices, setting the 266
- privileges. *See also* access
 - protection; password; protecting; security
 - file server access, description and use 200
- problems. *See also* troubleshooting
 - computer operation, causes and suggested solutions 304
 - disk not initialized message 307
 - disk unusable, causes and suggested solutions 307
 - disk won't eject, causes and suggested solutions 308
 - floppy disks, causes and suggested solutions 308
 - hard disk, causes and suggested solutions 309
 - keyboard, causes and suggested solutions 306
 - memory, not enough 314
 - mouse doesn't move the pointer, causes and suggested solutions 306

- pointer freezing, causes and suggested solutions 311
- printers, causes and suggested solutions 312
- screen, causes and suggested solutions 304
- software, symptoms, causes and suggested solutions 309
- startup, causes and suggested solutions 309
- strategies for solving 313
- viruses, strategies for preventing 302
- processor-direct slot. *See also* cards; customizing installing memory cache cards in 286
- ProDOS operating system. *See also* alternative operating systems for Apple II computers, converting files from 345
- products
 - new, where to see demonstrations 354
- program. *See* application programs; system software
- programming
 - help with 355
- propeller key or symbol. *See* Command key
- protecting
 - data. *See* backing up; copying; locking; saving
 - hardware. *See* maintenance
 - software. *See* backing up; locking; security; viruses
- pull-down menus 21. *See also* menus
- pulling the power plug. *See* troubleshooting
- Put Away command (File menu)
 - putting away items on the desktop with 149
- Q**
 - question mark
 - on disk icon, meaning 305
 - Quit command (File menu)
 - copying between application programs, use of 80
 - quitting application programs with 74, 109
 - quitting
 - application programs 74, 109
- R**
 - radio
 - interference, handling 293
 - RAM (random access memory). *See also* memory chips, SIMMs as a group of 287 expanding 287
 - RAM cache
 - MultiFinder use 106
 - setting in General Control Panel 106
 - random access memory. *See* RAM
 - rebuilding. *See also* maintenance desktop, avoiding problems by 317
 - receiving. *See also* networks files across a network 201
 - recording. *See also* MacroMaker keystrokes in a macro 331
 - recovery. *See also* troubleshooting crash 309
 - rectangle
 - dotted, significance of 7
 - reducing. *See also* printing paper size 119
 - removing. *See also* deleting; erasing
 - desk accessories 62, 258
 - device drivers, from System Folder 62
 - floppy disks 14
 - fonts 62, 251
 - highlighting 8
 - icons 14
 - MacroMaker 332
 - resources, from System Folder 62
 - renaming. *See also* naming disks 164, 175 documents 86, 139 non-Macintosh files 344
 - repairing. *See also* troubleshooting disks, with Disk First Aid 297
 - repeating characters. *See also* characters; customizing setting the rate and delay before 209
 - replacing. *See also* copying desktop patterns, without saving 224 documents, Alert box verification 89 selected text, in an icon name 32
 - resizing. *See also* windows windows 11, 19
 - resources. *See also* devices; drivers description (figure) 49 removing from System Folder 62 sharing by use of a network 183
 - Restart command (Special menu)
 - changing startup device with 179

- Restore settings command (File menu, Apple File Exchange) 344
 - restoring. *See also* maintenance; troubleshooting
 - editing actions 83
 - translator settings 344
 - retrieving
 - files on the file server 200
 - icons from the trash 15
 - Return key
 - Enter key use for some functions 42
 - keyboard shortcut for Save button in Save dialog box 87
 - moving the insertion point to the next line 323, 325, 327
 - reversing. *See also* editing
 - Undo command use for 83
 - revised. *See also* editing
 - documents, saving methods 86
 - RGB monitor.
 - See* color; monitors
 - ringing alarm icon
 - significance of 220
- S
- “sad Macintosh” icon
 - meaning of 305
 - Save As command (File menu)
 - saving revised documents by changing the document name 85, 87
 - Save command (File menu)
 - saving new documents with 85
 - saving revised documents, by overwriting previous versions 86
 - saving. *See also* backing up; editing
 - automatically, HyperCard feature 86
 - desktop patterns 224
 - desk accessories 258
 - documents 84–93
 - files
 - disk problems, causes and suggested solutions 307
 - on the file server 200
 - fonts 251
 - icon name changes 30–32
 - images, Scrapbook desk
 - accessory use for 91
 - information for quick retrieval. *See* Clipboard
 - macros 335
 - text, Scrapbook desk accessory use for 91
 - translator settings 344
 - version handling
 - documents 88
 - Scrapbook files 93
 - scanner. *See also* devices; SCSI
 - connecting to the Macintosh 266
 - scanning order 176
 - Scrapbook desk accessory. *See also* desk accessories
 - editing
 - contents of 93
 - operations in 91
 - saving text and images in 91
 - version handling 93
 - screen. *See also* devices; monitors
 - changing
 - brightness level 234
 - highlight color on 244
 - cleaning 294
 - designating color or gray shade 235
 - magnification with CloseView 352
 - messages
 - displaying 26
 - responding to 26
 - moving pointer on, adjusting the speed 204
 - problems, causes and solutions 304
 - saving
 - precautions 291
 - programs for 304
 - turning down brightness control 234
 - viewing
 - enhancing through magnification 350
 - icons by color 245
 - scripts 331. *See also* MacroMaker
 - initiating recording of (figure) 333
 - scroll arrows
 - displaying window contents with 16
 - scroll bar
 - clicking to display window contents 19
 - description and use 16
 - scroll box
 - dragging to display window contents 18
 - scrolling 16. *See also* user interface; windows
 - SCSI (Small Computer Systems Interface) devices. *See also* devices
 - connecting 266–269
 - ID number duplicated, as cause of failure to recognize a hard disk 309
 - Search Here command (Find File menu) 146

- searching. *See also* Find File command
 - for documents 144–146
- security. *See also* access
 - protection; locking; passwords
 - password protection in AppleShare 198
- selected
 - menu item, blinking rate, adjusting the 225
 - objects, deselecting 8
 - text, extending 31
- selecting. *See also* choosing; designating; editing
 - colors, number 235
 - commands 21
 - devices 40, 116
 - fonts to install 249
 - gray shades, number of 235
 - icons 6
 - colors 244
 - list
 - group of items in a 7
 - separate items in a 8
 - monitors 231–233
 - multiple
 - desk accessories 256
 - files for translation 341
 - icons and objects 7
 - startup items 68
 - networks 190
 - objects 6
 - printers 40, 193
 - text
 - in an icon name 29
 - while editing 7
 - translators 343
- sending. *See also* networks
 - data to other computers by modems 201
 - files across a network 201
- serial
 - ports, description 269, 271
 - transmission 269
- service
 - Apple, information about 318
- setting. *See also* changing; Control Panel
 - SCSI device number 266
- Set Startup command (Special menu)
 - specifying items to be opened with (figure) 65–69
 - turning MultiFinder on with 98
- setting up
 - monitors 281
 - networks 183
 - pages 118
 - printers 114, 187
 - system components 290
 - system software 48
- 720K
 - MS-DOS normal-density floppy disk, initializing 339
- sharing
 - computers and other resources with network users 183
 - files 183, 196
- shift-clicking 8. *See also* selecting
- Shift-Left Arrow
 - deselecting characters with 31
- Shift-Right Arrow
 - extending selected text with 31
- Shift key
 - deselecting objects with 8
 - entering optional characters with 328
 - producing uppercase letters 322, 324, 327
 - Sticky Keys combinations 347
- shortcuts
 - keyboard. *See* keyboard shortcuts
- Show Clipboard command (Edit menu) 78
- Shut Down command (Special menu) 111
- shutting down. *See also* screen saving; turning off
 - effect on Trash 14
 - procedures for 110–111
- SIMM (single-in-line memory module) 287
- size
 - box
 - resizing windows with 11 (figure) 9
 - desk accessories, obtaining the 256
 - fonts, obtaining the 249
 - listing folder contents by 150
 - windows, changing the 11
- slots
 - NuBus, description of 281
- socket.
 - See* port
- software. *See also* application
 - programs; desk accessories; system software
 - developers, assistance for 356
 - problems
 - bomb icon, causes and suggested solutions 309
 - pointer freezing, causes and suggested solutions 311
 - version, incompatibilities as source of problems 314
- sound
 - changing
 - volume 211
 - type of alert 213
 - connecting audio devices 276
 - Control Panel, changing sound settings with 211–214

- speaker. *See also* sound
 - built-in, adjusting the sound
 - volume of 211
 - volume, changing (figure) 38
- Special keys
 - Apple Extended Keyboard,
 - alternative operating system keys 327
- Special menu
 - Empty Trash command, erasing icon contents with 14
 - Erase Disk command 163, 174
 - Restart command, changing startup device with 179
 - Set Startup command
 - specifying items to be opened with (figure) 65–69
 - turning MultiFinder on with 98
 - Shut Down command 45, 111
- specifying. *See* designating
- spooler 195. *See also* printers; PrintMonitor
- starting. *See also* startup; stopping
 - application programs 5, 73
 - by opening documents 76
 - with MultiFinder 101
 - Font/DA Mover with Desk
 - Accessories option selected 257
 - Macintosh
 - preparing system for use 47–69
 - with MultiFinder on 98–100
 - macro script recording (figure) 333
 - operations with the mouse 2
 - printing 120
- startup. *See also* starting
 - disks
 - adding network software to 188
 - creating 48, 60–63
 - designating 176
 - making more room on 258
 - removing fonts restrictions 251
 - problems with, causes and suggested solutions 309
 - specifying, items to be opened on 65–69
 - stereo miniplug. *See also* devices; sound
 - connecting audio devices with 276
 - Sticky Keys. *See also* handicapped
 - turning on and off 348
 - stopping. *See also* starting
 - macro recording 334
 - work sessions, good methods for 109–111
 - storage devices. *See* devices
 - storage media
 - disks, managing 155–181
 - storing
 - documents, in folders 142
 - files, on the file server 200
 - floppy disks 292
 - folders, within folders 143
 - macros (figure) 333
 - strategies. *See also* maintenance; problems, troubleshooting
 - problem solving 313
 - submenus. *See also* menus
 - opening and using 23
 - sunlight. *See also* maintenance
 - precaution against 293
 - SuperDrive
 - characteristics and use 157
 - support. *See also* troubleshooting
 - Apple, information about 318
- swapping
 - disks 160
 - Scrapbook files 93
- switching
 - application programs or desk accessories, with MultiFinder 100
 - disks 160
- system
 - clock, purpose of 300
 - components, setting up 290
 - crash, strategies for handling 309
 - creating
 - customized 56–60
 - small 62
 - standard 52
 - files
 - finding a list of system-supplied 52
 - system resources in the System Folder (figure) 49
 - verifying what you need 49
 - memory
 - clearing 104
 - managing 102
 - System Additions disk
 - needed for installation
 - System 6.0
 - minimum recommended configuration 51
 - System Folder
 - contents
 - description and verification 49
 - for a Macintosh with a separate monitor (figure) 50
 - driver installation, printers 114
 - importance of keeping only one version on hard disks 315
 - PrintMonitor location 132

system software. *See also*
application programs;
desk accessories; software
installing 48, 49, 51–56
network, using 183
preparing for use 48
updating 63
upgrade, importance of 310
System Startup disk
needed for installation 51

T

Tab key

moving the insertion point
horizontally to the right
322, 324, 327

tablet. *See also* Apple Desktop Bus
(ADB); devices
graphics, adjusting mouse
tracking for operation
with 205

tape backup. *See also* devices
connecting to the Macintosh
266

technical documentation
Macintosh, where to find 354

telecommunications. *See also*
networks
connecting with another
computer by 201
linking the Macintosh in
telephone networks 271

telephone
lines, sending data to other
computers by 201
networks, linking the
Macintosh into 271

television. *See also* maintenance
interference on, handling of
293

temperature. *See also* maintenance

safe range 293
terminating
work sessions, good methods
for 109–111

terminators
connecting SCSI devices with
267
guidelines for using with SCSI
devices (table) 268

testing. *See also* maintenance
disks 297

text. *See also* documents; editing
copying 77, 79, 91
deleting 33, 82
desktop editing operations 29
editing 77
icon name 29
extending selected 31
inserting, in an icon name 34
pasting, into a document 78
saving, Scrapbook desk

accessory use for 91
selecting, while editing 7
smoothing, LaserWriter
capability 119
translation, Apple File
Exchange use for 339

32-Bit QuickDraw
installing 64
3.5 inch disks (MS-DOS). *See also*
devices; disks
initializing 337
reading with Apple SuperDrive
336

throwing away. *See also* deleting
unwanted applications,
documents, and icons in
Trash 14

time. *See also* date
changing 38, 215, 216
setting alert with Alarm Clock
desk accessory 218

title
pop-up menus, meaning of 24
title bar. *See also* user interface
meaning of 9
moving windows with 10
trackball. *See also* Apple Desktop
Bus (ADB); devices
connecting 273

tracking
mouse, adjusting 204
transferring.

See copying

translating
files 339

translator. *See also* Apple File
Exchange
active 341, 344
files, description 337
options, saving 344
selecting a 343

transmission. *See also* networks
of data, by modems 201

Trash
discarding icon contents with
14
disconnecting from a file server
with 199
ejecting floppy disks by
dragging to 15, 159
icon meaning 14

triangle
in menu, meaning of 23

troubleshooting. *See also*
maintenance
keyboard, handling spills 291
maintenance and 289–319
problems, causes and solutions
302–317
strategies 302
turning off
alarm 221

Macintosh 43, 45
 effect on Trash 14
turning on
 alarm 218
 Macintosh 43
 MultiFinder 98
12-hour clock
 setting and location 214, 215
24-hour clock
 setting and location 214, 215
type fonts, sources of 246
typing. *See also* characters
 accented characters 330
 difficulties, using Easy Access
 to help with 347
 errors, correcting 85
 touch, adjusting for 210

U

umlaut (¨)
 entering using Option-u 330
Undo command (Edit menu).
 See also editing
 canceling editing actions with
 83

Unix.

See A/UX

unlocking.

See locking

unreadable disk

 repairing with Disk First Aid
 297

updating

 system software 63, 310

uppercase letters

 typing with Caps Lock key
 322

user interface.

See desktop; icons; menus;
 mouse; title bar;
 windows

user name

changing with the Chooser
 (figure) 41

V

ventilation. *See also* maintenance
 monitor, warning against
 blocking 291
 NuBus cards 282, 286
 opening, warning against
 blocking 281

verifying

 memory amount in a
 particular system 103
 System Folder contents 49

versions. *See also* editing; saving
 document, creating 88
 Scrapbook, handling of 93

video. *See also* color; graphics;
 gray shades; monitors

 capability, effect on number of
 colors and gray shades
 236

cards

 connecting a monitor to
 276, 279

 listing those in use 236

 monitor number

 determined by 227

 NuBus, installing 281

 port, connecting a monitor to
 276

 socket, monitor number

 determined by 227

viewing. *See also* organizing

 desk accessory sizes 256

 fonts and font sizes 249

 icons by color 245

 optional characters with Key
 Caps 328

 window contents 16, 150

View menu

 displaying information about

 directory contents with
 150

 viewing icons by color 245

viruses. *See also* maintenance;
 security; troubleshooting
 strategies for prevention and
 elimination 302, 303

vision. *See also* handicapped
 aids for visually handicapped
 350

volume. *See also* sound

 sound, changing 211

W

warnings. *See also* maintenance;
 troubleshooting

 alert box use for 28

 A/UX, against initializing disk
 48

 automatic emptying of Trash
 14

 data loss during disk
 initialization 161

 disk programs, diagnosing
 with Disk First Aid 297

 electrical 290, 295

 floppy drives 292

 hard disk care 167

 memory expansion 287

 overwriting documents 89

 monitors, position of large
 291

 power requirements, NuBus
 cards 283

 screen damage 291

 SuperDrive, plastic
 placeholder should not
 be used 292

 system software upgrade,
 importance of 310

ventilation, importance of
 281, 282
 for monitors and
 Macintosh 281
where you are on the Macintosh
 finding out 94
windows. *See also* user interface
 activating 12
 changing shape of 11
 closing 13
 components of (figure) 9
 enlarging with zoom box 12
 listing the contents of 150
 moving 9, 12
 opening 5
 printing a directory of the files
 in 124
 resizing 11
 scrolling 16
 viewing contents by scrolling 16
work groups. *See also* networks
 connecting printers to
 networks 269
 setting up virus-detection
 stations in 303
work sessions. *See also*
 maintenance; managing
 good methods for ending
 109–111
world. *See also* protecting
 file server access privilege,
 description 200
wristwatch. *See also* pointers
 pointer change to, during save
 operation 86
write-protect. *See* locking

X, Y

X character. *See also*
 troubleshooting
 on disk icon 305

Z

zones (network). *See also*
 networks
 dividing a multiple network
 internet into 192
 meaning of (figure) 39
 selecting 40
 printers within 117
 sharing files through 197
zoom box
 enlarging windows with 12
 meaning of (figure) 9

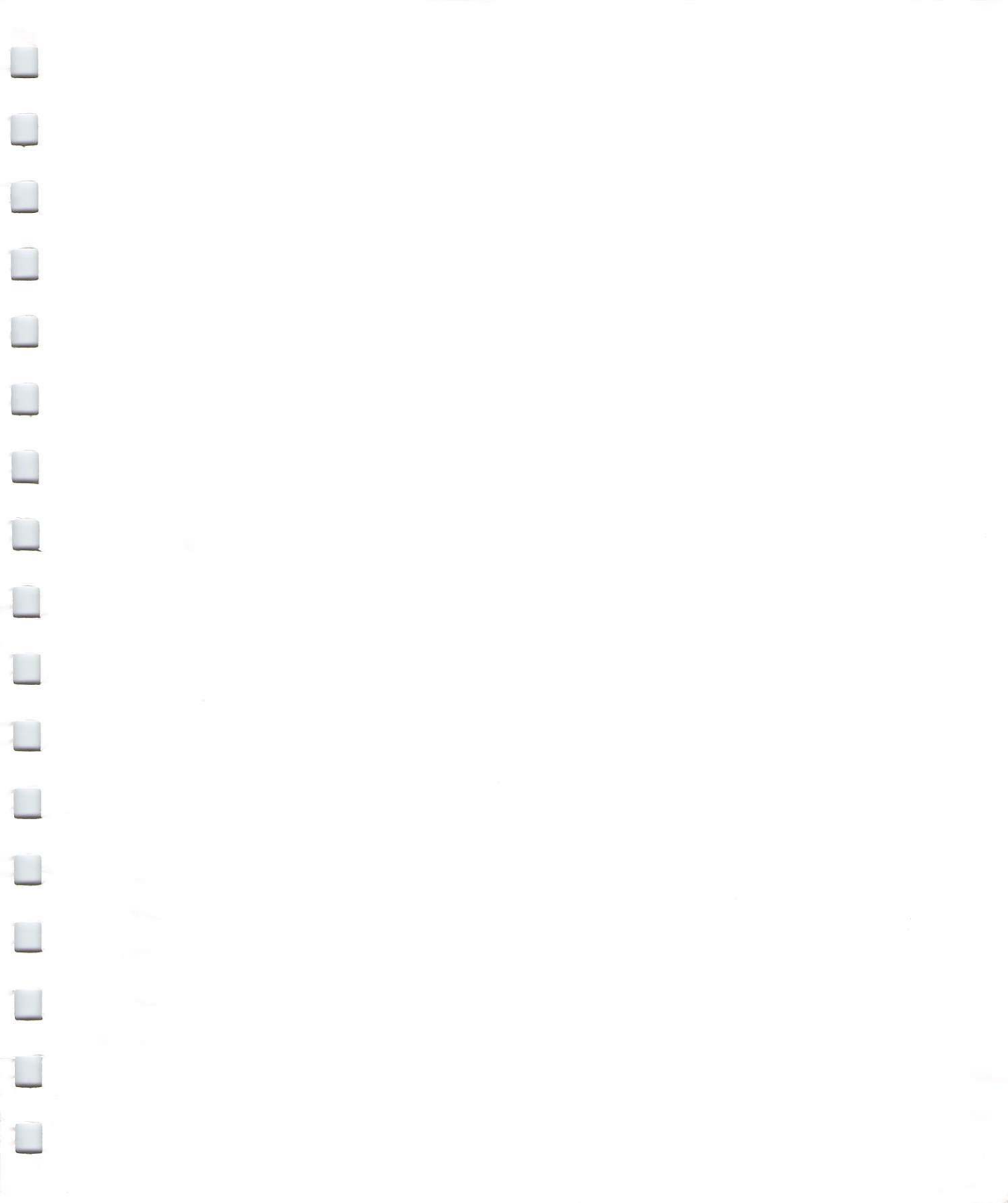

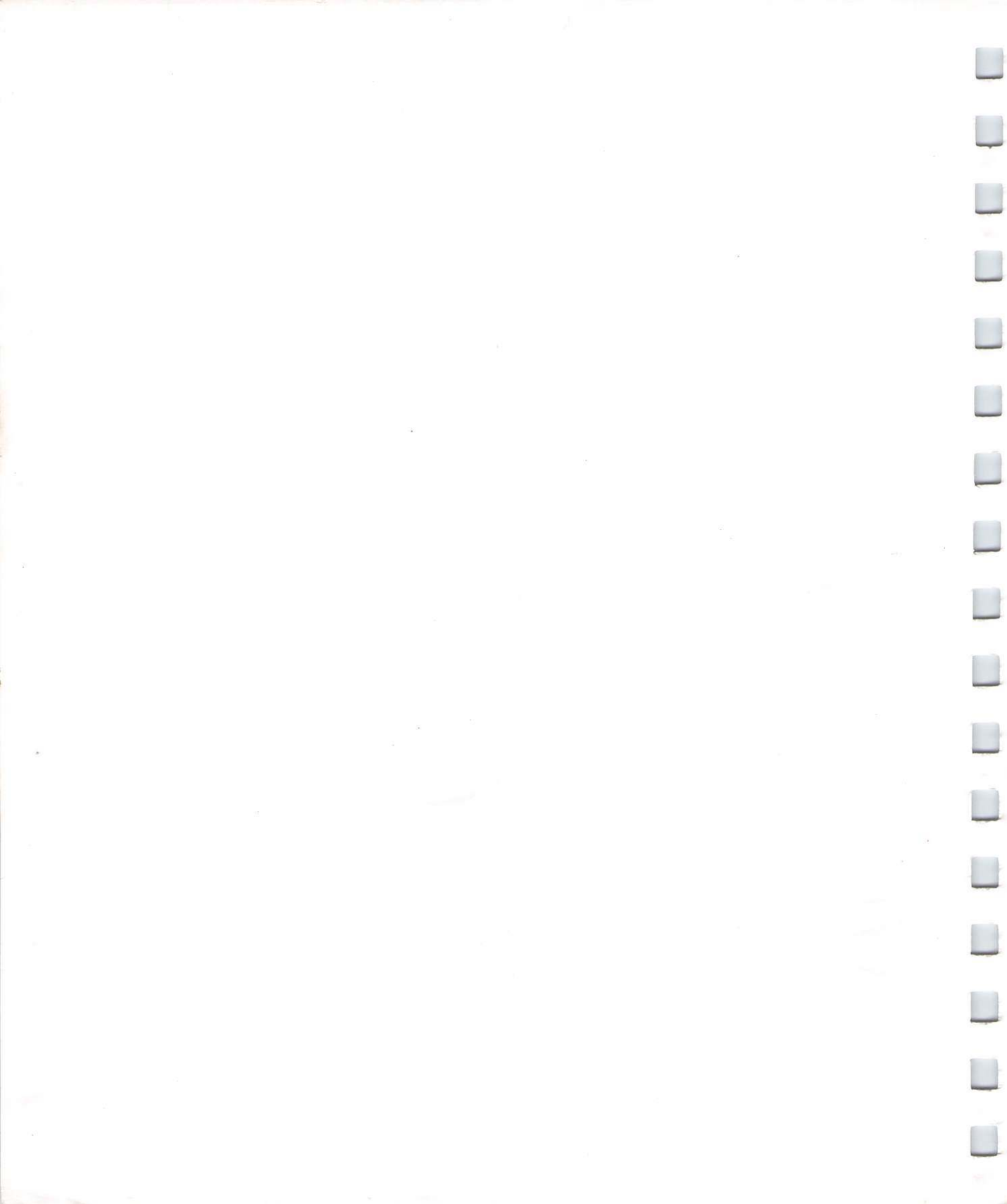

The Apple Publish

This Apple™ manual was
and composed on a des
system using Apple Mac
computers and Microsof
pages were created on A
LaserWriter™ printers. F
produced in QuarkXPre
directly to film on Linotr
Imagesetters.

Display type is Apple's c
condensed version of G
type is Adobe Garamon
ITC Zapf Dingbats.

POSTSCRIPT® , the LaserW
description language, w
Adobe Systems Incorpo



Tuck end flap inside back
cover when using manual.



Apple Computer, Inc.
20525 Mariani Avenue
Cupertino, CA 95014
(408) 996-1010
TLX 171-576

Z030-4015-A