

## SERVICE MANUAL

## Remote Control Color Television

## DS31650 (U.S.A.) ORIGINAL VERSION

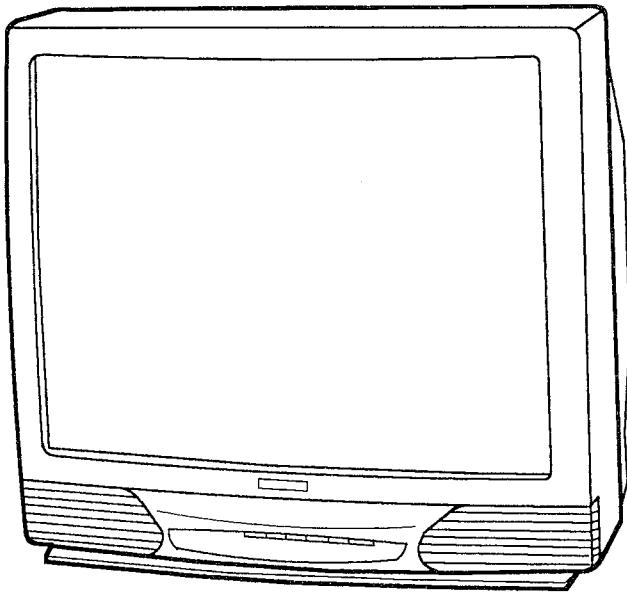

**Chassis No. 31650-00**

**NOTE:** Match the Chassis No. on the unit's back cover with the Chassis No. in the Service Manual.

**If the Original Version Service Manual Chassis No. does not match the unit's,** additional Service Literature is required. You **must** refer to "Notices" to the Original Service Manual prior to servicing the unit.

### Contents

Safety Instructions .....	2
Service Adjustments .....	3 - 5
P.I.F. Alignment	
Instructions .....	5
Service Hints .....	6
Mechanical Disassemblies .....	7 - 8
Chassis Electrical Parts list .....	9 - 17
Cabinet Parts list .....	18
Component and Testpoint	
Locations .....	19 - 20
Schematic Diagram .....	21 - 26

### Specifications

Power Rating .....	120V 60Hz
Antenna Input Impedance .....	75 $\Omega$
	UHF/VHF/CATV
Receiving Channel .....	2-13(VHF), 14-69(UHF), 01, 14-125(CATV)
Remote Ready .....	32 Key Remote Control
Sound Output .....	1.0W/CH
Intermediate Frequency	
Picture IF Carrier .....	45.75MHz
Sound Carrier .....	41.25MHz
Color Sub Carrier .....	42.17MHz
Picture Tube .....	M78JUA069X71
Semiconductors	
Integrated Circuits .....	8
Transistors .....	32
	Except within Tuner and RC Pre-Amp.
Cabinet Dimensions	
Width .....	766mm
Height .....	716mm
Depth .....	525.5mm

# SAFETY INSTRUCTIONS

## SAFETY PRECAUTIONS

**WARNING:** The chassis of this receiver has a floating ground with the potential of one half the AC line voltage in respect to earth ground. Service should not be attempted by anyone not familiar with the precautions necessary when working on this type of equipment.

The following precautions must be observed:

1. An isolation transformer should be connected in the power line between the receiver and the AC line before any service is performed on the receiver.
2. Comply with all cautions and safety-related notes provided on the side of the cabinet, inside the cabinet, on the chassis, and the picture tube.
3. When replacing a chassis in the cabinet, always be certain that all the protective devices are installed properly, such as control knobs, adjustment covers, shields and barriers.

DO NOT OPERATE THIS TELEVISION RECEIVER IF THE PROTECTIVE SHIELD IS NOT IN POSITION AND PROPERLY SECURED.

4. Before replacing the back cover of the set, thoroughly inspect the inside of the cabinet to see that no stray parts or tools have been left inside.  
Before returning any television to the customer, the service technician must perform the following safety checks to be sure that the unit is completely safe to operate without danger of electrical shock.

## ANTENNA COLD CHECK

Remove AC plug from the 120VAC outlet and place a jumper across the two blades. Connect one lead of an ohmmeter to the jumpered AC plug, and touch the other lead to each exposed antenna terminal (UHF and VHF combination antenna terminal). The resistance must measure between 1M ohm and 5.2M ohm. Any resistance value below or above this range indicates an abnormality which requires corrective action.

## LEAKAGE CURRENT CHECK

Plug the AC line cord directly into a 120 VAC outlet. (Do not use an isolation transformer for this check.) Use an AC voltmeter, that has 5000 ohms per volt or more sensitivity. Connect a 1500 ohm 10 watt resistor, paralleled by a 0.15  $\mu$ F 150 VAC capacitor, between a known good earth ground (water pipe, conduit, etc.) and all exposed metal parts of the cabinet (antennas, handle bracket, metal cabinet, screw heads, metal overlays, control shafts, etc.). Measure the AC voltage across the 1500 ohm resistor. The AC voltage should not exceed 750 mV. A reading exceeding 750 mV indicates that a dangerous potential exists. The fault must be located and corrected. Repeat the above test with the receiver power plug reversed.

NEVER RETURN A RECEIVER TO THE CUSTOMER WITHOUT TAKING THE NECESSARY CORRECTIVE ACTION.

READING SHOULD NOT EXCEED 750 mV  
AC VOLT METER  
(5000 ohms per volt or more sensitivity)

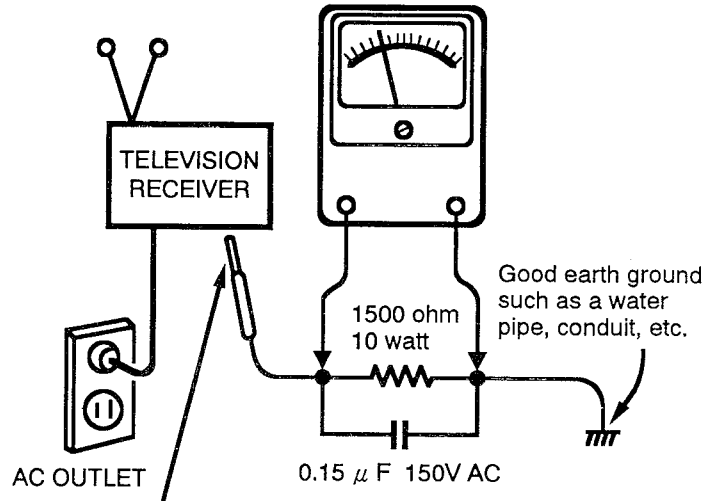

To be touched to all of exposed metal parts.

Voltmeter Hook-up for Leakage Current Check

## X-RADIATION PRECAUTION

The primary source of X-RADIATION in solid-state receiver is the picture tube. The picture tube is specially constructed to limit X-Ray emission. For continued X-RADIATION protection, the replacement tube must be the same type as the original (including the suffix letter in the part numbers). Excessive high voltage may produce potentially hazardous X-RADIATION. To avoid such hazards, the high voltage must be maintained within specific limits. Refer to the X-RADIATION WARNING NOTE on the CHASSIS SCHEMATIC in this service manual for specific high voltage limits. If the high voltage exceeds specified limits, check the components specified on the chassis schematic diagram and take the necessary corrective action. Carefully follow the instructions for the +B Voltage Check and the High Voltage Check to maintain the high voltage within the specified limits.

## HIGH VOLTAGE HOLD-DOWN TEST

To prevent X-RADIATION from the picture tube due to excessive high voltage, a HOLD-DOWN circuit is provided in the high voltage circuits. Every time the receiver is serviced, the high voltage HOLD-DOWN circuit must be tested for proper operation. Refer to the "HIGH VOLTAGE HOLD-DOWN TEST" in service adjustments.

## PRODUCT SAFETY NOTICE

When replacing components in a receiver, always keep in mind the necessary product safety precautions. Pay special attention to the replacement of components marked with a star (★) in the parts list and in the schematic diagram. To ensure safe product operation, it is necessary to replace those components with the exact same PARTS.

# SERVICE ADJUSTMENTS

## ANTENNA CONNECTION

This receiver is designed for UHF/VHF reception. A 75 ohm terminal is provided for UHF and VHF receptions.

When connecting the CATV antenna system, connect the 75 ohm coaxial cable directly to 75 ohm terminal. For 300 ohm UHF/VHF antenna, use an adapter (not included with the TV set).

## CIRCUIT PROTECTION

Fuse F601 (4A) is included in the AC line. This fuse must be replaced with the proper fuse. (See Parts List.)

### CAUTION

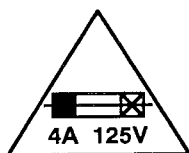

**FOR CONTINUED PROTECTION AGAINST A RISK OF FIRE, REPLACE ONLY WITH THE SAME TYPE 4A, 125V FUSE.**

**ATTENTION : POUR MAINTENIR LA PROTECTION CONTRE LES RISQUES D'INCENDIE UTILISER UN FUSIBLE DE RECHANGE DE MEME TYPE 4A, 125V.**

## +B VOLTAGE CHECK

Connect voltmeter + lead to "TJ1 130V" and - lead to ground (TE7). Connect receiver to AC 120V line. Tune receiver to an active channel. Reset the PICTURE ADJUST to "FACTORY PRESET" level. Voltage must measure between +128.0V and +132.0V. If the voltage is out of this range, the power circuit must be checked. No +B adjustment is provided on this chassis.

## RF-AGC ADJUSTMENT

1. Tune receiver to strongest VHF station in your area.
2. Set contrast and brightness controls for maximum.
3. Turn RF-AGC Control (VR141) in the direction which causes snow to appear, then in the opposite direction until the snow just disappears.

## VERTICAL SIZE ADJUSTMENT

Tune receiver to an active channel. Adjust Vert. Size Control (VR501) for full scan.

## VERTICAL CENTERING ADJUSTMENT

Tune receiver to an active channel. Check that picture is in the center of TV screen. If picture center is too low, connect resistor R513 (470 ohm, 1W). If picture center is too high, connect resistor R512 (470 ohm, 1W).

## FOCUS ADJUSTMENT

Adjust Focus Control (T402) for well-defined scanning lines.

## GRAYSCALE ADJUSTMENT

1. Set Red (VR704) and Blue (VR705) Drive Controls to mid position. Set Blue (VR703), Green (VR702) and Red (VR701) Bias Controls to minimum (fully counter-clockwise).
2. Set Screen Control (T402) to minimum (fully counter-clockwise).
3. Set Service Switch (SW701) to "SERVICE" position on Pix Tube Board.
4. Advance Screen Control (T402) clockwise to obtain just visible one color line. If line does not appear, place this control to maximum (fully clockwise).
5. Advance each Bias Control to obtain just visible white line.

6. Set Service Switch (SW701) to "NORMAL" position.
7. Adjust Red and Blue Drive Controls alternately to produce normal black and white picture in highlight areas.
8. Check for proper grayscale at all brightness levels.

**Note:** If Grayscale Adjustment is made after picture tube replacement, check brightness level adjustment.

## BRIGHTNESS LEVEL ADJUSTMENT

**Note:** High Voltage Check, and AGC and Grayscale Adjustments must be completed before attempting Brightness Level Adjustment.

1. Connect a color bar generator to the antenna terminal.
2. Switch the generator to the crosshatch pattern.
3. Reset the PICTURE ADJUST to "FACTORY PRESET" level.
4. Connect Voltmeter (high impedance) + lead to terminal "TP51" and - lead to terminal "TP50" as shown in Figure 1.
5. Turn off the receiver and disconnect the AC power cord (AC 120V line).
6. While pressing the "MENU" key, connect the AC power cord again. Then "SUBBRIGHT ADJUST" display appears. (See Figure 2.)
7. Adjust Sub-Brightness Level with "+" or "-" key for 650mVdc.
8. Press the "MENU" key to turn off the SUBBRIGHT ADJUST display.
9. Check brightness level on every active channels. Readjust (repeat step 5-9 above) if necessary.

**Note:** Do not set to excessive brightness levels, otherwise the contrast level is suppressed.

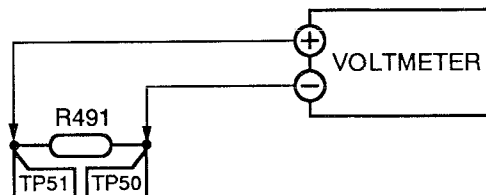

Figure 1. Connecting Voltmeter

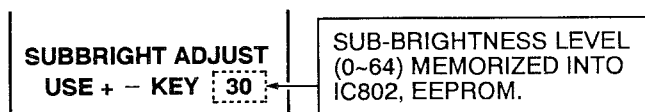

Figure 2. SUBBRIGHT ADJUST Display

## HIGH VOLTAGE CHECK

**Note:** +B (+130V) Voltage Check and Grayscale Adjustment must be completed before attempting High Voltage Check.

1. Connect high voltage voltmeter + lead to anode of picture tube, and connect - lead to ground.
2. Tune receiver to an active channel and confirm TV is operating properly.
3. Eliminate the beam current by adjusting contrast and brightness controls to minimum.
4. Confirm high voltage is within 28.5KV to 30.5KV. If reading is not within range, check horizontal circuit. No high-voltage adjustment is provided on this chassis.

### HIGH VOLTAGE HOLD-DOWN TEST

Every time the receiver is serviced, the HIGH VOLTAGE HOLD-DOWN circuit must be tested for proper operation by following these steps:

1. Connect receiver to AC 120V line. Tune receiver to an active channel. Reset the PICTURE ADJUST to FACTORY PRESET level.
2. Check that the voltage measured between "TP7" and "TE7" (ground side) is within 16.5V to 21V.  
If the voltage is out of this range, the hold-down circuit must be checked.
3. Connect DC Voltage supply (+23V) to "TP7" through a 100 ohm, 1/4W resistor and "TE7"(ground side). Set the DC supply to 23V. The receiver should shutdown, losing raster and sound. Then the receiver should turn off automatically. This reaction indicates that the hold-down circuit is functioning properly. If the receiver does not shutdown, a malfunction is indicated and its cause must be found and corrected.
4. To obtain picture again, remove the DC supply and wait a short time. Now turn on the receiver.

### AFT FIELD ADJUSTMENT

1. Disconnect the AC power cord (AC 120V line).
2. Connect voltmeter + lead to "TP113" on Main Board and - lead to Main Board ground. Ground "TP113" with a short jumper lead.
3. Connect the AC power cord again, and then press the "POWER" key to turn on the receiver.
4. Tune TV set to a good-quality active color channel, using keys 0 ~ 9 on the remote control transmitter.  
Wait a few seconds until properly tuned, and then remove the short lead from terminal "TP113".
5. Turn AFT Centering Coil (T161) on Main Board fully clockwise, and then gradually turn the coil counterclockwise until voltage is at the maximum level (approximately 3.8V). Continue to turn the coil counterclockwise until voltage is at the minimum level (approximately 1.2V), and then turn the coil clockwise until voltage indicates 2.5V. Voltage change in the coil adjustment is shown in Figure 3.
6. Disconnect voltmeter from chassis.  
Select every active channel with keys 0 ~ 9 and scanning keys, and check to be sure the AFT is operating properly.

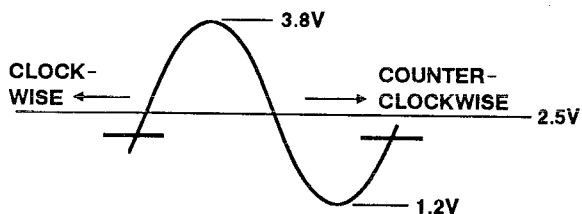

Figure 3. Voltage Change in Coil Adjustment

### REMOTE CONTROL TRANSMITTER SERVICE NOTE

To repair remote control transmitter, check as follows:

1. Check battery installation and battery voltage.  
If necessary, replace batteries.
2. Connect oscilloscope to Q9901 "Base" and ground.

3. Check the amplitude of the pulse on the base by pressing the remote control transmitter keys.
4. If pulse does not appear, replace with a new unit.

### DISPLAY PLL ADJUSTMENT

1. Connect Voltmeter + lead to "TP501" (PLL Filter) and - lead to ground.
2. Tune receiver to an active channel.
3. Check the voltage if it is within  $2.45 \pm 0.75$  Vdc.
4. If it is out of the range, change the value of capacitor VC801 as below:
  - If it is higher than the range, change the value of VC801 from 18 pF to 15 pF.
  - If it is lower than the range, change the value of VC801 from 18 pF to 22 pF.

### SOUND ADJUSTMENT

1. Tune receiver to strongest VHF station in your area.
2. Set volume control to middle level.
3. Adjust Sound I.F. Transformer (T131) for the best sound and minimum noise.

### MULTI-SOUND SECTION ADJUSTMENTS

#### 1.5 fH B.P.F. Adjustment

1. Connect DC Supply (+15.0V) to "TP2" and ground.
2. Connect Signal Generator to "TP301" through capacitor (10  $\mu$  F, 16V, Non-Polarized Electrolytic) and ground.
3. Ground "TP20" with a jumper lead.
4. Connect an Audio Voltmeter to "TP310" and ground.
5. Set Signal Output to 22.9kHz, 290mVp-p.
6. Adjust 1.5fH B.P.F. Adjustment (VR3403) for a reading of minimum voltage.

#### Stereo VCO Adjustment

7. Remove Audio Voltmeter from "TP310".
8. Connect DC Voltmeter to "TP312" and ground.
9. Change Signal Output to 15.734kHz, 140mVp-p.
10. Read DC voltage at "TP312".
11. Change connection of DC Voltmeter to "TP313" and ground.
12. Adjust Stereo VCO Adjustment (VR3406) for "TP313" voltage to conform to "TP312" voltage.

#### Multi-Sound Section Alignment

Variable resistors VR3411 and VR3421 are adjusted for stereo separation and have been preset at the factory. If these parts are to be replaced, first check the resistance values or adjustment positions of the original parts and set the replacement parts to the same values or positions.

If these parts are replaced, check the stereo and bilingual sound on a received broadcast multi-sound program.

If separation is unacceptable, tune the adjustment positions of the replacement parts slightly. Adjust VR3421 (Low Separation) for minimum low frequencies in the right speaker. Adjust VR3411 (High Separation) for minimum high frequencies in the left speaker. Repeat adjustments for best separation.

### COMB FILTER ADJUSTMENT

1. Connect color-bar generator to antenna terminal.
2. Reset the PICTURE ADJUST to "FACTORY PRESET" level.
3. Connect scope to TP27-GND.
4. Adjust VR300 for minimum chroma components in the video signals.

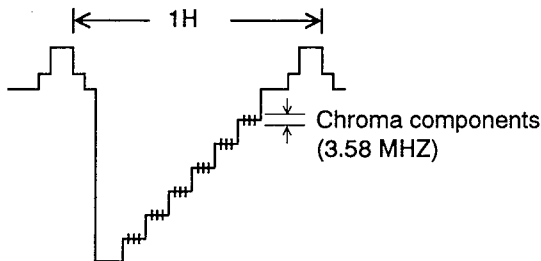

### PURITY AND CONVERGENCE ADJUSTMENT

Convergence and Purity have been aligned at the factory. No re-alignment is necessary.

## P.I.F. ALIGNMENT INSTRUCTIONS

**GENERAL:** Shielding around the P.I.F. circuit must be in place. To prevent possible damage to the TV circuit, the TV set should be OFF when you connect the alignment equipment to the circuit.

### P.I.F. ALIGNMENT

Connect the test equipment and set the TV controls as follows:

#### BIAS SUPPLY

Apply IF AGC +6.0V to TP12, and +15.0V DC supply to TP2.

#### SCOPE

Connect scope VERT INPUT to SCOPE VERT on SWEEP/MARKER GENERATOR.  
Connect scope EXTERNAL HORIZ IN to scope HORIZ on SWEEP/MARKER GENERATOR.

#### SWEEP/MARKER GENERATOR

Connect SWEEP OUTPUT to TP132 through the matching pad as shown in Figure 1. Connect INPUT PROBE to TP16 through scope input pad as shown in Figure 2.

#### TELEVISION

Ground TP11 with jumper lead.  
Turn on the TV set and tune to an inactive channel.

Align P.I.F. as follows:

STEP AND MARKERS
P.I.F. Detection Stage Adjustment : 41.67MHz, 42.17MHz, 42.67MHz, and 45.75MHz markers ON.
ALIGNMENT PROCEDURES
Response characteristics should be similar to Figure 3. Adjust P.I.F. Detection Transformer(T151) so that the Picture Marker point of the P.I.F. detection spectrum is at 45.75MHz as shown in Figure 3.

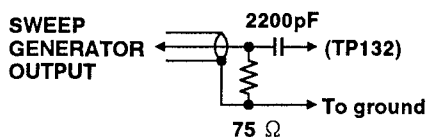

Figure 1. Matching Pad

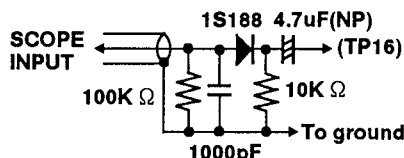

Figure 2. Scope Input Pad

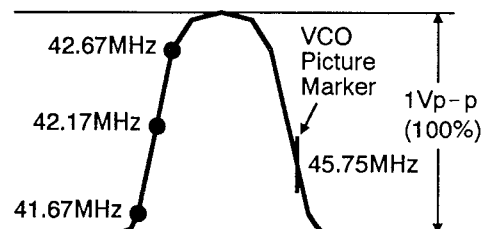

Figure 3. P.I.F. Detection Stage

# SERVICE HINTS

## POWER FAILURE DETECTOR

This set is equipped with "Power Failure detector" installed on the CPU which checks abnormal failure for several of the power supply circuits and some including power supply from the Horizontal Output Trans.

If unexpected failure is caused by any of the following which then results in lower voltage supply, the set will turn off by itself in 1.5 seconds to prevent any damages:

- Failure within the power supply circuits.
- Unexpected short circuit by load side from the supply.
- Stoppage of the Horizontal Output Oscillation caused by the Hold Down Circuit for X-Radiation protection.

The power will shut off itself within 3.0 seconds as long as any of these failures remain uncorrected.

Check the following if the set is turned off caused by the power failure detector.

1. Connect a DC Voltmeter to the following TEST POINT and check proper voltage supply.

TJ4	26V
TJ6	12V

2. If at least one of the voltage is lower, the power failure detector circuit should work to turn the set off.

# MECHANICAL DISASSEMBLIES

## CABINET BACK REMOVAL

1. Refer to Figure 1, remove 13 screws.
2. Pull cabinet back off and remove cabinet back.

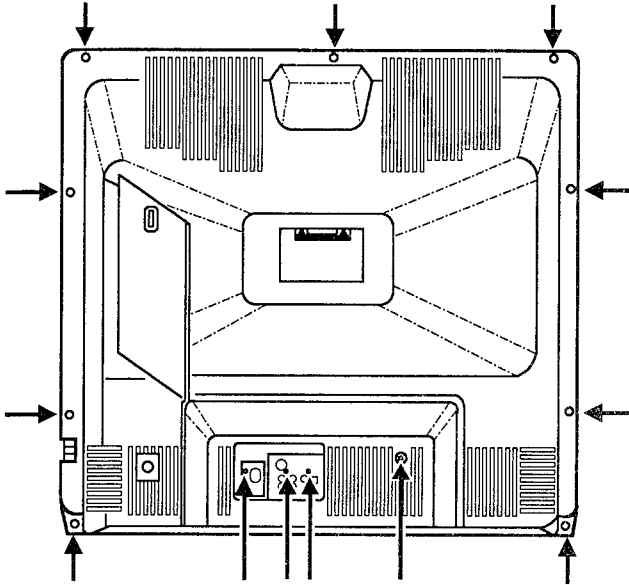

Figure 1. Cabinet Back Removal

## CHASSIS REMOVAL

1. Remove cabinet back.
2. Unplug degaussing coil socket (KD), and anode lead, speaker socket (K58R), Deflection yoke (KX), Pix Tube board and Pix Tube ground leads.
3. Remove chassis completely by sliding straight back.

## PICTURE TUBE REMOVAL

**CAUTION:** Do not disturb the deflection yoke or magnet assembly on the picture tube neck. Care must be taken to keep these assemblies intact, unless picture tube is being replaced. Discharge the picture tube to the coating before handling the tube.

1. Remove chassis, referring to "Chassis Removal" instructions.
2. Place cabinet's front face down on a soft surface.
3. Remove the screw on each corner of the picture tube and GENTLY lift the picture tube out of the cabinet.
4. Install a replacement picture tube in reverse order. Properly install the degaussing coil and picture tube grounding lead on the picture tube. See Figure 2.

**Note:** If Picture Tube is being replaced, mount the Degaussing Coil properly on the tube. See Figure 2.

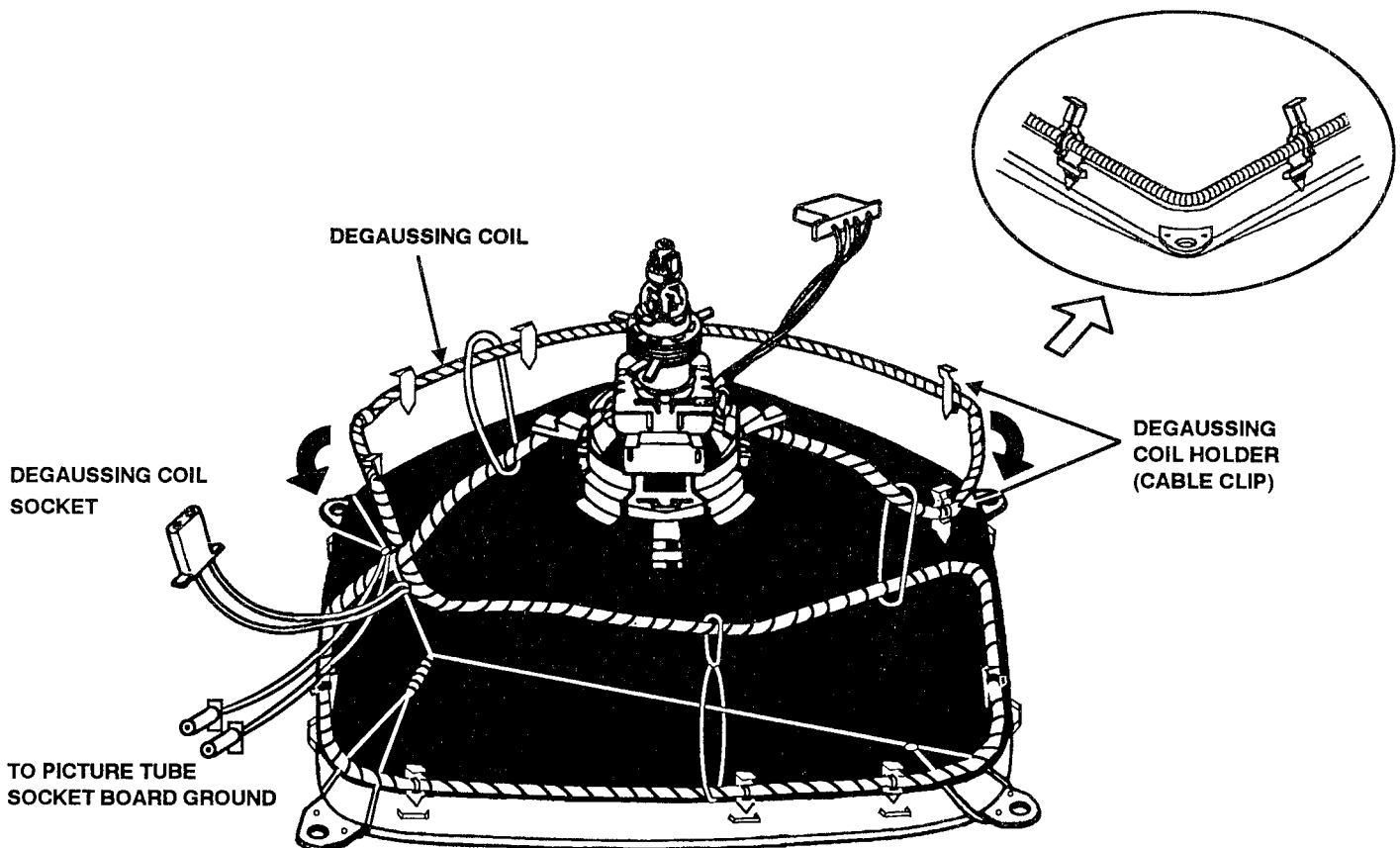

Figure 2. Picture Tube Replacement

## REMOTE CONTROL TRANSMITTER DISASSEMBLY

1. Press the hook of battery cover forward and lift it up in the direction of the arrow to remove it. See Figure 1.
2. Remove two screws. See Figure 1.
3. Starting at the rear of the remote, push the top section of the cabinet in and pull up the bottom sections. Proceed by pressing in at the sides of top section, while pulling the bottom from the top. See Figure 2.

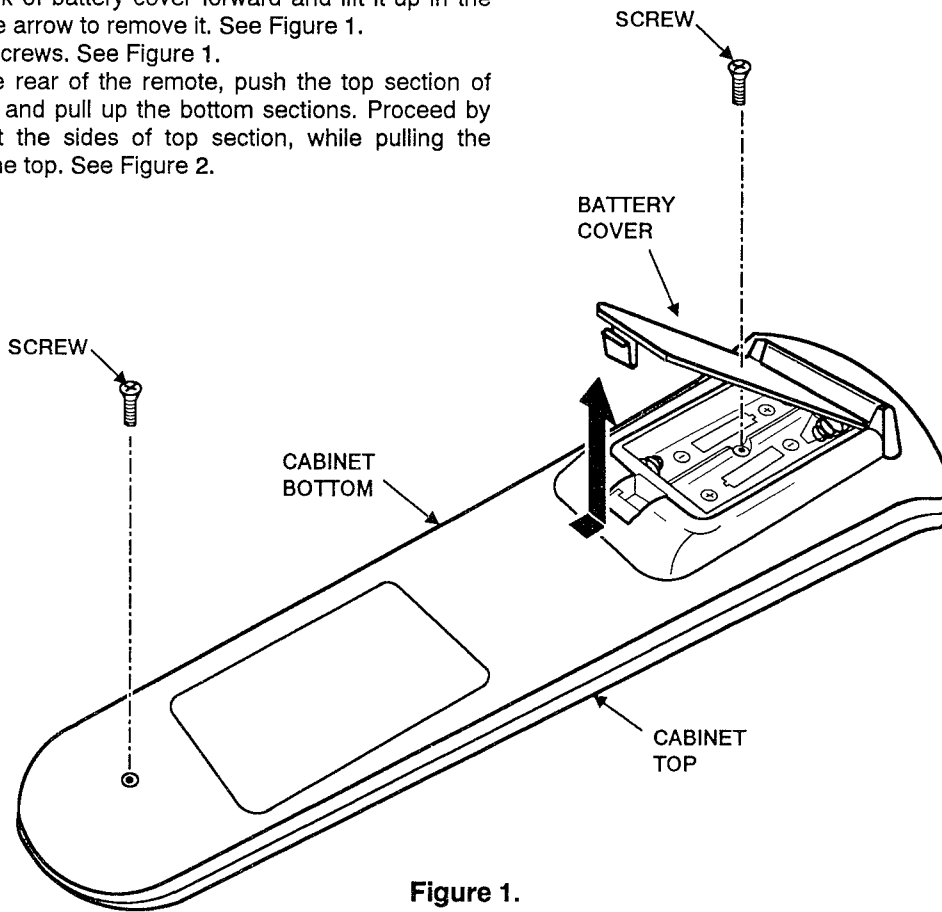

Figure 1.

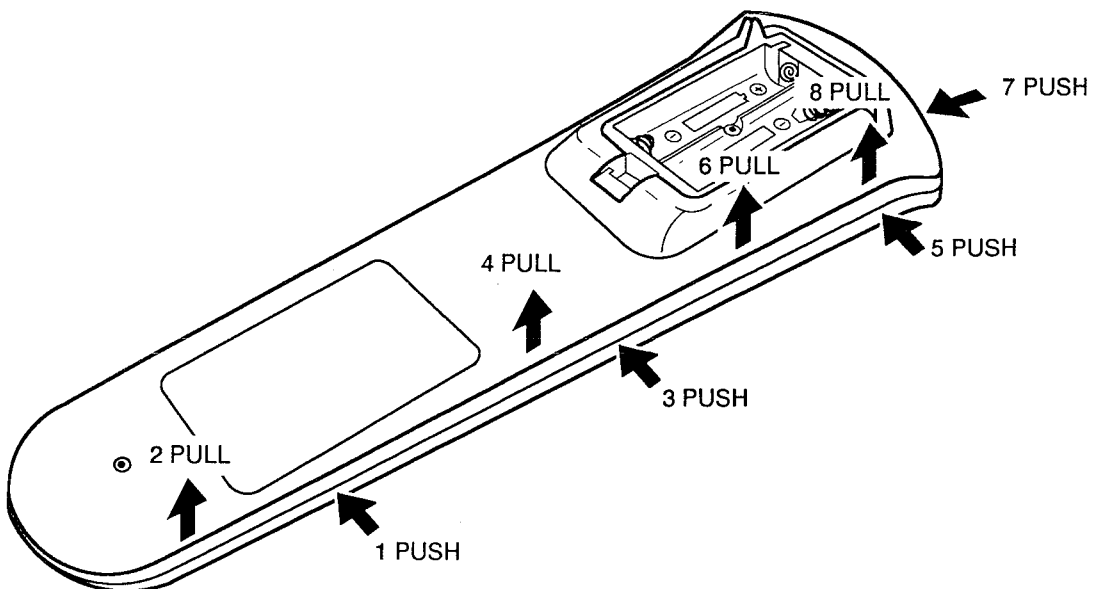

Figure 2.

## Remote Control Transmitter Disassembly

# CHASSIS ELECTRICAL PARTS LIST

**CAUTION:** To protect against electric shock and for continued product safety, refer to Safety Precautions, X-Radiation Precaution, High Voltage Hold-Down Test and Product Safety Notice on Page 2.

## PRODUCT SAFETY NOTICE

PRODUCT SAFETY SHOULD BE CONSIDERED WHEN A COMPONENT REPLACEMENT IS MADE IN ANY AREA OF A RECEIVER. COMPONENTS INDICATED BY A STAR(★) IN THIS PARTS LIST AND THE SCHEMATIC DIAGRAM DESIGNATE COMPONENTS IN WHICH SAFETY CAN BE OF SPECIAL SIGNIFICANCE. IT IS PARTICULARLY RECOMMENDED THAT ONLY PARTS DESIGNATED ON THE FOLLOWING PARTS LIST BE USED FOR COMPONENT REPLACEMENT DESIGNATED BY A STAR. NO DEVIATIONS FROM RESISTANCE, WATTAGE AND VOLTAGE RATINGS MAY BE MADE FOR REPLACEMENT ITEMS DESIGNATED BY A STAR.

**NOTE ;** Parts having Location Number are located in the following boards.

- Numbers under 600 Series ..... In the Main Board.
- Numbers 700 Series ..... In the Picture Tube Socket Board.
- Numbers 800 Series ..... In the Main Board.
- Numbers 900 Series ..... Out of Board.
- Numbers 1000 Series ..... In the AV Board.
- Numbers 1900 Series ..... In the Main Board.
- Numbers 3400 Series ..... In the Main Board.
- Numbers 3500 Series ..... In the AV Board.
- Numbers 3600 Series ..... In the AV Board.
- Numbers 7900 Series ..... In the Main Board.

Schematic Location	Part No.	Description	Schematic Location	Part No.	Description
--------------------	----------	-------------	--------------------	----------	-------------

## CAPACITORS

**NOTES:**  
Read description in the Capacitor as follows:

(Example)  
CERAMIC 100P K 50V

Rated Voltage

Tolerance Symbols:  
less than 10PF  
A...Not specified  
B... ± 0.1PF  
D... ± 0.5PF  
G... ± 2PF  
S...+0 - 0.25PF  
more than 10PF  
A...Not specified  
B... ± 0.1%  
D... ± 0.5%  
G... ± 2%  
J... ± 5%  
L... ± 15%  
N... ± 30%  
Q...+30 - 10%  
U...+75 - 10%  
W...+100 - 10%  
Y...+150 - 10%

C... ± 0.25PF  
F... ± 1PF  
R...+0.25 - 0PF  
E...+0 - 1PF

C... ± 0.25%  
F... ± 1%  
H... ± 3%  
K... ± 10%  
M... ± 20%  
P...+100 - 0%  
T...+50 - 10%  
V...+20 - 10%  
X...+40 - 20%  
Z...+80 - 20%

Rated Value: P...Pico Farad U...Micro Farad

Material:  
CERAMIC ..... Ceramic  
MT-PAPER ..... Metalized Paper  
POLYESTER ..... Polyester  
MT-POLYEST ..... Metalized Polyester  
POLYPRO ..... Polypropylene  
MT-POLYPRO ..... Metalized Polypropylene  
COMPO-FILM ..... Composite Film  
MT-COMPO ..... Metalized Composite  
STYRENE ..... Styrene  
TA-SOLID ..... Tantalum Solid  
AL-SOLID ..... Aluminum Solid  
ELECT ..... Electrolytic  
NP-ELECT ..... Non-Polarized Electrolytic  
OS-SOLID ..... Aluminum Solid with Organic Semiconductive Electrolytic

C001	403 049 0008	ELECT	1U M	50V
C002	403 049 0008	ELECT	1U M	50V
C003	403 074 5702	CERAMIC	560P K	50V
C004	403 074 5702	CERAMIC	560P K	50V
C005	403 044 9501	ELECT	100U M	25V
C006	403 044 9501	ELECT	100U M	25V
C007	403 044 9501	ELECT	100U M	25V
C008	403 057 3107	POLYESTER	0.1U K	50V
	403 067 5603	MT-COMPO	0.1U J	50V
	403 166 6808	MT-POLYEST	0.1U J	63V
C009	403 057 3107	POLYESTER	0.1U K	50V
	403 067 5603	MT-COMPO	0.1U J	50V
	403 166 6808	MT-POLYEST	0.1U J	63V
C010	403 044 1703	ELECT	470U M	16V
C011	403 044 1703	ELECT	470U M	16V
C015	403 042 4805	ELECT	1000U M	16V
C101	403 039 9004	ELECT	1000U M	10V
C102	403 049 0008	ELECT	1U M	50V
C103	403 069 8305	CERAMIC	0.01U Z	50V
C104	403 038 8602	ELECT	33U M	6.3V
C131	403 067 6709	MT-COMPO	0.22U J	50V
	403 166 8109	MT-POLYEST	0.22U J	63V
C133	403 069 8305	CERAMIC	0.01U Z	50V
C141	403 069 8305	CERAMIC	0.01U Z	50V
C142	403 069 8305	CERAMIC	0.01U Z	50V
C143	403 043 9106	ELECT	47U M	16V
C144	403 069 8305	CERAMIC	0.01U Z	50V
C151	403 048 6308	ELECT	0.47U M	50V
C152	403 041 8804	ELECT	10U M	16V
C153	403 069 8305	CERAMIC	0.01U Z	50V
C154	403 068 9006	CERAMIC	100P K	50V
C155	403 069 0507	CERAMIC	1000P K	50V
C156	403 060 8403	POLYESTER	0.033U K	50V
	403 060 8809	POLYESTER	0.033U K	50V
C161	403 028 2009	CERAMIC	56P J	50V
C202	403 069 8305	CERAMIC	0.01U Z	50V
C203	403 009 3100	CERAMIC	100P J	50V
C205	403 028 1705	CERAMIC	56P J	50V
C208	403 011 3501	CERAMIC	120P J	50V
C209	403 041 8804	ELECT	10U M	16V

Schematic Location	Part No.	Description	Schematic Location	Part No.	Description
C214	403 049 0008	ELECT 1U M 50V		403 186 2804	CERAMIC 4700P K 1K
C215	403 048 6308	ELECT 0.47U M 50V	C609	404 051 8303	ELECT 680U M 200V
C216	403 049 0008	ELECT 1U M 50V		404 059 6905	ELECT 680U M 200V
C217	403 012 4101	CERAMIC 15P J 50V	C611	403 082 6302	POLYPRO 0.01U J 200V
C219	403 069 8305	CERAMIC 0.01U Z 50V	C612	403 067 6501	MT-COMPO 0.18U J 50V
C241	403 042 2405	ELECT 100U M 16V		403 166 8208	MT-POLYEST 0.18U J 63V
C251	403 043 9106	ELECT 47U M 16V	C613	403 057 7303	POLYESTER 0.012U J 50V
C252	403 058 3403	POLYESTER 0.015U K 50V		403 214 5203	POLYESTER 0.012U J 50V
	403 058 3809	POLYESTER 0.015U K 50V	C621	403 075 7101	CERAMIC 1000P K 500V
C253	403 049 9803	ELECT 2.2U M 50V	C622	403 047 5005	ELECT 470U M 25V
C281	403 069 0507	CERAMIC 1000P K 50V	★C625	403 185 9002	CERAMIC 2700P K 1K
C301	403 069 8305	CERAMIC 0.01U Z 50V	C626	403 045 9807	ELECT 2200U M 25V
C302	403 033 3305	CERAMIC 82P J 50V	C627	403 045 7803	ELECT 220U M 25V
C303	403 042 2405	ELECT 100U M 16V	C628	404 037 0703	ELECT 470U M 160V
C304	403 013 1703	CERAMIC 150P J 50V		404 038 0900	ELECT 470U M 160V
C307	403 011 3501	CERAMIC 120P J 50V	★C632	404 008 6604	CERAMIC 1000P K 125V
C324	403 069 0507	CERAMIC 1000P K 50V	C681	403 075 7101	CERAMIC 1000P K 500V
C351	403 049 0008	ELECT 1U M 50V	C682	403 047 5005	ELECT 470U M 25V
C352	403 069 0507	CERAMIC 1000P K 50V	C683	403 044 6609	ELECT 10U M 25V
C371	403 048 6308	ELECT 0.47U M 50V	C684	403 043 9106	ELECT 47U M 16V
C401	403 042 2405	ELECT 100U M 16V	C701	403 075 9709	CERAMIC 1800P K 500V
C402	403 049 9803	ELECT 2.2U M 50V	C703	403 069 0507	CERAMIC 1000P K 50V
C403	403 060 8403	POLYESTER 0.033U K 50V	C705	403 069 0507	CERAMIC 1000P K 50V
	403 060 8809	POLYESTER 0.033U K 50V	C707	403 069 0507	CERAMIC 1000P K 50V
C404	403 073 6403	CERAMIC 470P K 50V	★C708	403 077 2708	CERAMIC 1000P P 2K
C406	403 076 3607	CERAMIC 470P K 500V		403 175 3409	CERAMIC 1000P P 2K
C407	403 076 0507	CERAMIC 2200P K 500V	C801	403 067 5603	MT-COMPO 0.1U J 50V
C408	403 134 1903	ELECT 4.7U M 160V		403 166 6808	MT-POLYEST 0.1U J 63V
★C411	404 052 1907	MT-POLYPRO 8200P H 1.5K	C802	403 041 8804	ELECT 10U M 16V
★C412	404 052 1907	MT-POLYPRO 8200P H 1.5K	C803	403 067 5603	MT-COMPO 0.1U J 50V
★C413	403 083 5304	POLYPRO 0.033U J 400V		403 166 6808	MT-POLYEST 0.1U J 63V
★C414	403 083 3904	POLYPRO 0.018U J 400V	C806	403 069 8305	CERAMIC 0.01U Z 50V
★C416	403 082 9808	POLYPRO 0.33U J 200V	C811	403 049 0008	ELECT 1U M 50V
★C417	403 082 8405	POLYPRO 0.22U J 200V	C814	403 023 9706	CERAMIC 39P J 50V
C419	403 066 0005	MT-POLYEST 2.2U J 100V	C818	403 071 7402	CERAMIC 2200P K 50V
C421	403 038 6301	ELECT 220U M 6.3V	C819	403 049 9803	ELECT 2.2U M 50V
C422	403 066 6106	MT-POLYEST 0.47U J 250V	C821	403 041 8804	ELECT 10U M 16V
C461	403 049 9803	ELECT 2.2U M 50V	C826	403 049 9803	ELECT 2.2U M 50V
C462	403 038 1603	ELECT 100U M 6.3V	C827	403 072 5308	CERAMIC 2700P K 50V
C466	403 047 3100	ELECT 47U M 25V	C829	403 049 0008	ELECT 1U M 50V
C470	403 067 7805	MT-COMPO 0.47U J 50V	C830	403 069 8305	CERAMIC 0.01U Z 50V
	403 166 7706	MT-POLYEST 0.47U J 63V	C831	403 076 2006	CERAMIC 330P K 500V
C481	403 043 0202	ELECT 220U M 16V	C832	403 061 9805	POLYESTER 0.047U J 50V
C482	403 115 0802	ELECT 22U M 100V		403 062 0207	POLYESTER 0.047U J 50V
C483	403 042 2405	ELECT 100U M 16V	C834	403 058 2604	POLYESTER 0.015U J 50V
C484	403 051 0607	ELECT 4.7U M 50V		403 058 3007	POLYESTER 0.015U J 50V
C486	403 076 3607	CERAMIC 470P K 500V	C851	403 041 8804	ELECT 10U M 16V
C487	403 052 8503	ELECT 1000U M 35V	C856	403 041 8804	ELECT 10U M 16V
C491	403 043 9106	ELECT 47U M 16V	C861	403 041 8804	ELECT 10U M 16V
C492	403 043 9106	ELECT 47U M 16V	C868	403 041 8804	ELECT 10U M 16V
C493	404 056 5307	NP-ELECT 2.2U M 100V	C871	403 041 8804	ELECT 10U M 16V
C501	403 044 1703	ELECT 470U M 16V	C883	403 049 0008	ELECT 1U M 50V
C502	403 057 0601	POLYESTER 0.01U K 50V	C886	403 049 0008	ELECT 1U M 50V
	403 057 1004	POLYESTER 0.01U K 50V	C892	403 041 8804	ELECT 10U M 16V
C503	403 205 4703	ELECT 4.7U K 25V	C1002	403 046 9905	ELECT 4.7U M 25V
C504	403 045 9807	ELECT 2200U M 25V	C1003	403 046 9905	ELECT 4.7U M 25V
C505	403 072 4400	CERAMIC 270P K 50V	C1011	403 049 0800	ELECT 1U M 50V
C506	403 204 6104	ELECT 1U M 50V	C1012	403 049 0008	ELECT 1U M 50V
C507	403 053 2104	ELECT 220U M 35V	C1021	403 049 0008	ELECT 1U M 50V
C508	403 054 1502	ELECT 470U M 35V	C1022	403 049 0008	ELECT 1U M 50V
C509	403 069 0507	CERAMIC 1000P K 50V	C3401	403 046 9905	ELECT 4.7U M 25V
C511	403 063 2309	POLYESTER 0.068U K 50V	C3402	403 048 6308	ELECT 0.47U M 50V
	403 063 2705	POLYESTER 0.068U K 50V	C3404	403 046 9905	ELECT 4.7U M 25V
C556	403 041 8804	ELECT 10U M 16V	C3406	403 046 9905	ELECT 4.7U M 25V
★C601	404 047 3909	MT-POLYEST 0.22U M 125V	C3407	403 073 8308	CERAMIC 4700P K 50V
	404 066 2105	MT-POLYEST 0.22U M 275V	C3408	403 046 9905	ELECT 4.7U M 25V
★C606	404 008 6802	CERAMIC 2200P M 125V	C3409	403 062 0504	POLYESTER 0.047U K 50V
★C608	403 165 9404	CERAMIC 4700P K 1K		403 062 1006	POLYESTER 0.047U K 50V

Schematic Location	Part No.	Description	Schematic Location	Part No.	Description
C3411	403 046 9905	ELECT 4. 7U M 25V		407 007 9904	DIODE GMA01
C3412	403 046 9905	ELECT 4. 7U M 25V		407 012 4406	DIODE 1SS133
C3413	403 090 6004	TA-SOLID 3. 3U K 10V		407 012 5809	DIODE 1SS176
	403 124 7908	TA-SOLID 3. 3U K 10V		407 013 1206	DIODE 1S1555
C3414	403 049 0008	ELECT 1U M 50V		407 013 4207	DIODE 1S2076
C3416	403 090 3607	TA-SOLID 10U K 10V		407 013 7109	DIODE 1S2473
	403 090 3706	TA-SOLID 10U K 10V		408 008 2406	DIODE 1N4148
C3417	403 046 9905	ELECT 4. 7U M 25V	D463	407 013 1008	DIODE 1S1553
C3418	403 060 0001	POLYESTER 2700P J 50V		407 013 4306	DIODE 1S2076A
	403 060 0308	POLYESTER 2700P J 50V		407 013 6508	DIODE 1S2471
C3419	403 041 2109	ELECT 47U M 10V		408 008 2406	DIODE 1N4148
C3422	403 048 6308	ELECT 0. 47U M 50V	D481	407 007 6606	DIODE ES1
C3423	403 046 9905	ELECT 4. 7U M 25V		407 124 5506	DIODE RMPG06G
C3424	403 062 4908	POLYESTER 5600P J 50V		407 124 6404	DIODE ERA18-04
	403 138 5600	POLYESTER 5600P J 50V	D482	407 011 4407	DIODE TVR1G
C3426	403 057 7303	POLYESTER 0. 012U J 50V	D483	407 007 6606	DIODE ES1
	403 214 5203	POLYESTER 0. 012U J 50V		407 124 5506	DIODE RMPG06G
C3436	403 041 8804	ELECT 10U M 16V		407 124 6404	DIODE ERA18-04
C3602	403 058 3403	POLYESTER 0. 015U K 50V	D486	407 054 0008	ZENER DIODE RD10EB2(10V)
	403 058 3809	POLYESTER 0. 015U K 50V		407 151 1304	ZENER DIODE UZ-10BCB(10V)
C3603	403 048 4205	ELECT 0. 33U M 50V	D487	407 005 8602	DIODE ERA15-02
C3604	403 043 9106	ELECT 47U M 16V		407 011 3004	DIODE S5277B
C3606	403 049 0008	ELECT 1U M 50V		407 088 6502	DIODE MPG06D
C3607	403 048 4205	ELECT 0. 33U M 50V		408 009 9404	DIODE 1N40021D
C3608	403 058 3403	POLYESTER 0. 015U K 50V	D501	407 005 8602	DIODE ERA15-02
	403 058 3809	POLYESTER 0. 015U K 50V		407 011 3004	DIODE S5277B
C3611	403 069 0507	CERAMIC 1000P K 50V		407 088 6502	DIODE MPG06D
C3613	403 069 0507	CERAMIC 1000P K 50V		408 009 9404	DIODE 1N40021D
C7921	403 042 7707	ELECT 22U M 16V	D503	407 056 2307	ZENER DIODE RD36EB1(36V)
C7922	403 041 8804	ELECT 10U M 16V		407 163 9503	ZENER DIODE UZ-36BCA(36V)
VC801	403 014 0309	CERAMIC 18P J 50V	★D601	407 005 7605	DIODE EM2B
				407 013 3200	DIODE 1S1887A
				408 008 8606	DIODE GP15G
			★D602	407 005 7605	DIODE EM2B
				407 013 3200	DIODE 1S1887A
				408 008 8606	DIODE GP15G
			★D603	407 005 7605	DIODE EM2B
				407 013 3200	DIODE 1S1887A
				408 008 8606	DIODE GP15G
D102	407 056 8002	ZENER DIODE RD5. 1EB2(5. 1V)	★D604	407 005 7605	DIODE EM2B
	407 056 8200	ZENER DIODE RD5. 1EB3(5. 1V)		407 013 3200	DIODE 1S1887A
	407 151 8402	ZENER DIODE UZ-5. 1BCB(5. 1V)		408 008 8606	DIODE GP15G
	407 163 8209	ZENER DIODE UZ-5. 1BCC(5. 1V)		407 005 7605	DIODE EM2B
D201	407 005 4505	DIODE DS442X		407 013 3200	DIODE 1S1887A
	407 007 9904	DIODE GMA01		408 008 8606	DIODE GP15G
	407 012 4406	DIODE 1SS133	D609	407 007 6903	DIODE ES1Z
	407 012 5809	DIODE 1SS176		407 124 5605	DIODE RMPG06D
	407 013 1206	DIODE 1S1555		407 124 6503	DIODE ERA18-02
	407 013 4207	DIODE 1S2076		408 009 9008	DIODE BYD33D
	407 013 7109	DIODE 1S2473	D610	407 013 1008	DIODE 1S1553
	408 008 2406	DIODE 1N4148		407 013 4306	DIODE 1S2076A
D351	407 013 1008	DIODE 1S1553		407 013 6508	DIODE 1S2471
	407 013 4306	DIODE 1S2076A		408 008 2406	DIODE 1N4148
	407 013 6508	DIODE 1S2471	D611	407 057 6304	ZENER DIODE RD7. 5EB1(7. 5V)
	408 008 2406	DIODE 1N4148		407 151 8808	ZENER DIODE UZ-7. 5BCA(7. 5V)
D361	407 005 4505	DIODE DS442X	★D612	407 002 9602	PHOTO COUPLE TLP621-1-GB
	407 007 9904	DIODE GMA01		407 104 2402	PHOTO COUPLE PC817C
	407 012 4406	DIODE 1SS133		407 106 6101	PHOTO COUPLE PC817D
	407 012 5809	DIODE 1SS176		407 147 5705	PHOTO COUPLE ON3131S
	407 013 1206	DIODE 1S1555	D614	407 013 1008	DIODE 1S1553
	407 013 4207	DIODE 1S2076		407 013 4306	DIODE 1S2076A
	407 013 7109	DIODE 1S2473		407 013 6508	DIODE 1S2471
	408 008 2406	DIODE 1N4148		408 008 2406	DIODE 1N4148
D406	407 006 4108	DIODE ERB44-04	★D621	407 007 7603	DIODE EU2
D407	407 095 8001	DIODE ERD07-15L	D622	407 054 1807	ZENER DIODE RD11EB3(11V)
★D421	407 158 1307	ZENER DIODE HZ11B2L(11V)		407 164 6709	ZENER DIODE UZ-11BCC(11V)
★D422	407 158 1307	ZENER DIODE HZ11B2L(11V)	★D624	407 129 6706	DIODE RU4YX LF-L1
D428	407 054 7007	ZENER DIODE RD16EB1(16V)	★D625A	407 129 7000	DIODE RU4AM LF-L1
	407 054 7205	ZENER DIODE RD16EB3(16V)	D681	407 005 8602	DIODE ERA15-02
	407 163 9305	ZENER DIODE UZ-16BCA(16V)		407 011 3004	DIODE S5277B
	407 164 7201	ZENER DIODE UZ-16BCC(16V)		407 088 6502	DIODE MPG06D
D429	407 005 4505	DIODE DS442X			



Schematic Location	Part No.	Description	Schematic Location	Part No.	Description
	405 004 3109	TR 2SA564A-Q(CU)		405 006 1707	TR 2SA933S-Q
	405 004 3208	TR 2SA564A-R(CU)		405 006 1806	TR 2SA933S-R
	405 004 4205	TR 2SA608-E-CTV-NP	0372	405 001 7407	TR 2SA1015-O(SAN)
	405 004 4809	TR 2SA608-F-CTV-NP		405 001 7605	TR 2SA1015-Y(SAN)
	405 006 1707	TR 2SA933S-Q		405 004 3109	TR 2SA564A-Q(CU)
Q202	405 006 1806	TR 2SA933S-R		405 004 3208	TR 2SA564A-R(CU)
	405 001 7407	TR 2SA1015-O(SAN)		405 004 4205	TR 2SA608-E-CTV-NP
	405 001 7605	TR 2SA1015-Y(SAN)		405 004 4809	TR 2SA608-F-CTV-NP
	405 004 3109	TR 2SA564A-Q(CU)		405 006 1707	TR 2SA933S-Q
	405 004 3208	TR 2SA564A-R(CU)		405 006 1806	TR 2SA933S-R
	405 004 4205	TR 2SA608-E-CTV-NP	0401	405 013 6207	TR 2SC2271-D-CTV
	405 004 4809	TR 2SA608-F-CTV-NP		405 013 6306	TR 2SC2271-E-CTV
	405 006 1707	TR 2SA933S-Q	★Q402	405 082 2407	TR 2SD1879-CTV-YB
	405 006 1806	TR 2SA933S-R	0461	405 011 8401	TR 2SC1740S-Q
Q213	405 001 7605	TR 2SA1015-Y(SAN)		405 011 8500	TR 2SC1740S-R
	405 004 3208	TR 2SA564A-R(CU)		405 011 8609	TR 2SC1740S-S
	405 004 4809	TR 2SA608-F-CTV-NP		405 012 2002	TR 2SC1815-GR
	405 006 1806	TR 2SA933S-R		405 012 2309	TR 2SC1815-Y
Q281	405 001 7407	TR 2SA1015-O(SAN)		405 019 1909	TR 2SC536-E-NP
	405 001 7605	TR 2SA1015-Y(SAN)		405 019 2708	TR 2SC536-F-NP
	405 004 3109	TR 2SA564A-Q(CU)		405 019 3804	TR 2SC536-G-NP
	405 004 3208	TR 2SA564A-R(CU)		405 020 7501	TR 2SC945A-PA
	405 004 4205	TR 2SA608-E-CTV-NP	0462	405 020 7709	TR 2SC945A-QA
	405 004 4809	TR 2SA608-F-CTV-NP		405 064 7307	TR 2SB1274-Q-RA
	405 006 1707	TR 2SA933S-Q	0481	405 064 7406	TR 2SB1274-R-RA
	405 006 1806	TR 2SA933S-R		405 023 5009	TR 2SD400-E-MP
Q303	405 011 8401	TR 2SC1740S-Q	0486	405 023 5306	TR 2SD400-F-MP
	405 011 8500	TR 2SC1740S-R		405 023 5009	TR 2SD400-E-MP
	405 011 8609	TR 2SC1740S-S	0491	405 023 5306	TR 2SD400-F-MP
	405 012 2002	TR 2SC1815-GR		405 011 8401	TR 2SC1740S-Q
	405 012 2101	TR 2SC1815-O		405 011 8500	TR 2SC1740S-R
	405 012 2309	TR 2SC1815-Y		405 011 8609	TR 2SC1740S-S
	405 019 1909	TR 2SC536-E-NP		405 012 2002	TR 2SC1815-GR
	405 019 2708	TR 2SC536-F-NP		405 012 2101	TR 2SC1815-O
	405 019 3804	TR 2SC536-G-NP		405 012 2309	TR 2SC1815-Y
	405 020 7501	TR 2SC945A-PA		405 019 1909	TR 2SC536-E-NP
	405 020 7709	TR 2SC945A-QA		405 019 2708	TR 2SC536-F-NP
	405 020 7907	TR 2SC945A-RA		405 019 3804	TR 2SC536-G-NP
Q304	405 011 8401	TR 2SC1740S-Q		405 020 7501	TR 2SC945A-PA
	405 011 8500	TR 2SC1740S-R		405 020 7709	TR 2SC945A-QA
	405 011 8609	TR 2SC1740S-S	★Q601	405 020 7907	TR 2SC945A-RA
	405 012 2002	TR 2SC1815-GR	0604	405 095 9004	TR 2SC4423-CTV
	405 012 2101	TR 2SC1815-O	0605	405 058 0208	TR 2SC3807-R-CTV-YA
	405 012 2309	TR 2SC1815-Y		405 001 7407	TR 2SA1015-O(SAN)
	405 019 1909	TR 2SC536-E-NP		405 001 7605	TR 2SA1015-Y(SAN)
	405 019 2708	TR 2SC536-F-NP		405 004 3109	TR 2SA564A-Q(CU)
	405 019 3804	TR 2SC536-G-NP		405 004 3208	TR 2SA564A-R(CU)
	405 020 7501	TR 2SC945A-PA		405 004 4205	TR 2SA608-E-CTV-NP
	405 020 7709	TR 2SC945A-QA		405 004 4809	TR 2SA608-F-CTV-NP
	405 020 7907	TR 2SC945A-RA		405 006 1707	TR 2SA933S-Q
Q306	405 011 8401	TR 2SC1740S-Q	0621	405 006 1806	TR 2SA933S-R
	405 011 8500	TR 2SC1740S-R		405 059 9804	TR 2SD1913-Q-RA
	405 011 8609	TR 2SC1740S-S	0681	405 059 9903	TR 2SD1913-R-RA
	405 012 2002	TR 2SC1815-GR		405 011 8401	TR 2SC1740S-Q
	405 012 2101	TR 2SC1815-O		405 011 8500	TR 2SC1740S-R
	405 012 2309	TR 2SC1815-Y		405 011 8609	TR 2SC1740S-S
	405 019 1909	TR 2SC536-E-NP		405 012 2002	TR 2SC1815-GR
	405 019 2708	TR 2SC536-F-NP		405 012 2309	TR 2SC1815-Y
	405 019 3804	TR 2SC536-G-NP		405 019 2708	TR 2SC536-F-NP
	405 020 7501	TR 2SC945A-PA		405 019 3804	TR 2SC536-G-NP
	405 020 7709	TR 2SC945A-QA		405 020 7501	TR 2SC945A-PA
	405 020 7907	TR 2SC945A-RA	0682	405 020 7709	TR 2SC945A-QA
Q371	405 001 7407	TR 2SA1015-O(SAN)		405 023 5009	TR 2SD400-E-MP
	405 001 7605	TR 2SA1015-Y(SAN)	0701	405 023 5306	TR 2SD400-F-MP
	405 004 3109	TR 2SA564A-Q(CU)		405 014 8408	TR 2SC2568(1)-K
	405 004 3208	TR 2SA564A-R(CU)		405 014 8507	TR 2SC2568(1)-L
	405 004 4205	TR 2SA608-E-CTV-NP		405 014 8606	TR 2SC2568(1)-M
	405 004 4809	TR 2SA608-F-CTV-NP		405 041 6507	TR 2SC2621-D-RA
				405 041 6705	TR 2SC2621-E-RA

Schematic Location	Part No.	Description	Schematic Location	Part No.	Description
--------------------	----------	-------------	--------------------	----------	-------------

Q703	405 066 4304	TR 2SC2621-C-RA	
	405 066 9903	TR 2SC2688(1)-K	
	405 067 0008	TR 2SC2688(1)-L	
	405 067 0107	TR 2SC2688(1)-M	
	406 000 3605	TR 2SC3620(LB-SAN-1)	
	405 014 8408	TR 2SC2568(1)-K	
	405 014 8507	TR 2SC2568(1)-L	
	405 014 8606	TR 2SC2568(1)-M	
	405 041 6507	TR 2SC2621-D-RA	
	405 041 6705	TR 2SC2621-E-RA	
	405 066 4304	TR 2SC2621-C-RA	
	405 066 9903	TR 2SC2688(1)-K	
	405 067 0008	TR 2SC2688(1)-L	
	405 067 0107	TR 2SC2688(1)-M	
Q705	406 000 3605	TR 2SC3620(LB-SAN-1)	
	405 014 8408	TR 2SC2568(1)-K	
	405 014 8507	TR 2SC2568(1)-L	
	405 014 8606	TR 2SC2568(1)-M	
	405 041 6507	TR 2SC2621-D-RA	
	405 041 6705	TR 2SC2621-E-RA	
	405 066 4304	TR 2SC2621-C-RA	
	405 066 9903	TR 2SC2688(1)-K	
	405 067 0008	TR 2SC2688(1)-L	
	405 067 0107	TR 2SC2688(1)-M	
	406 000 3605	TR 2SC3620(LB-SAN-1)	
	405 001 7407	TR 2SA1015-O(SAN)	
	405 001 7605	TR 2SA1015-Y(SAN)	
	405 004 3109	TR 2SA564A-Q(CU)	
405 004 3208	TR 2SA564A-R(CU)		
405 004 4205	TR 2SA608-E-CTV-NP		
405 004 4809	TR 2SA608-F-CTV-NP		
405 006 1707	TR 2SA933S-Q		
405 006 1806	TR 2SA933S-R		
Q881	405 011 8401	TR 2SC1740S-Q	
	405 011 8500	TR 2SC1740S-R	
	405 011 8609	TR 2SC1740S-S	
	405 012 2002	TR 2SC1815-GR	
	405 012 2101	TR 2SC1815-O	
	405 012 2309	TR 2SC1815-Y	
	405 019 1909	TR 2SC536-E-NP	
	405 019 2708	TR 2SC536-F-NP	
	405 019 3804	TR 2SC536-G-NP	
	405 020 7501	TR 2SC945A-PA	
	405 020 7709	TR 2SC945A-QA	
	405 020 7907	TR 2SC945A-RA	
	Q882	405 011 8401	TR 2SC1740S-Q
		405 011 8500	TR 2SC1740S-R
405 011 8609		TR 2SC1740S-S	
405 012 2002		TR 2SC1815-GR	
405 012 2101		TR 2SC1815-O	
405 012 2309		TR 2SC1815-Y	
405 019 1909		TR 2SC536-E-NP	
405 019 2708		TR 2SC536-F-NP	
405 019 3804		TR 2SC536-G-NP	
405 020 7501		TR 2SC945A-PA	
405 020 7709		TR 2SC945A-QA	
405 020 7907		TR 2SC945A-RA	
Q1011		405 011 8401	TR 2SC1740S-Q
		405 011 8500	TR 2SC1740S-R
	405 011 8609	TR 2SC1740S-S	
	405 012 2002	TR 2SC1815-GR	
	405 012 2101	TR 2SC1815-O	
	405 012 2309	TR 2SC1815-Y	
	405 019 1909	TR 2SC536-E-NP	
	405 019 2708	TR 2SC536-F-NP	
	405 019 3804	TR 2SC536-G-NP	
	405 020 7501	TR 2SC945A-PA	
	405 020 7709	TR 2SC945A-QA	
	405 020 7907	TR 2SC945A-RA	
	405 011 8401	TR 2SC1740S-Q	
	405 011 8500	TR 2SC1740S-R	
405 011 8609	TR 2SC1740S-S		
405 012 2002	TR 2SC1815-GR		
405 012 2101	TR 2SC1815-O		
405 012 2309	TR 2SC1815-Y		
405 019 1909	TR 2SC536-E-NP		
405 019 2708	TR 2SC536-F-NP		
405 019 3804	TR 2SC536-G-NP		
405 020 7501	TR 2SC945A-PA		
405 020 7709	TR 2SC945A-QA		
405 020 7907	TR 2SC945A-RA		

Q1021	405 020 7907	TR 2SC945A-RA
	405 011 8401	TR 2SC1740S-Q
	405 011 8500	TR 2SC1740S-R
	405 011 8609	TR 2SC1740S-S
	405 012 2002	TR 2SC1815-GR
	405 012 2101	TR 2SC1815-O
	405 012 2309	TR 2SC1815-Y
	405 019 1909	TR 2SC536-E-NP
	405 019 2708	TR 2SC536-F-NP
	405 019 3804	TR 2SC536-G-NP
	405 020 7501	TR 2SC945A-PA
	405 020 7709	TR 2SC945A-QA
	405 020 7907	TR 2SC945A-RA
	Q3431	405 011 8401
405 011 8500		TR 2SC1740S-R
405 011 8609		TR 2SC1740S-S
405 012 2002		TR 2SC1815-GR
405 012 2101		TR 2SC1815-O
405 012 2309		TR 2SC1815-Y
405 019 1909		TR 2SC536-E-NP
405 019 2708		TR 2SC536-F-NP
405 019 3804		TR 2SC536-G-NP
405 020 7501		TR 2SC945A-PA
405 020 7709		TR 2SC945A-QA
405 020 7907		TR 2SC945A-RA

## RESISTORS

### NOTES:

Read description in the Resistor as follows:

(Example)

CARBON 4.7K J A 1/4W

Rated Wattage

Performance Symbols:

A...General B...Non-flammable

Z...Low noise

Other...Temperature coefficient

Tolerance Symbols:

A... ± 0.05% B... ± 0.1% C... ± 0.25%

D... ± 0.5% F... ± 1% G... ± 2%

J... ± 5% K... ± 10% M... ± 20%

P...+5 - 15%

Rated Value, ohms:

K...1,000 M...1,000,000

Material:

CARBON ..... Carbon

MT-FILM ..... Metal Film

OXIDE-MT ..... Oxide Metal Film

SOLID ..... Composition

MT-GLAZE ..... Metal Glaze

WIRE WOUND ..... Wire Wound

CERAMIC RES .... Ceramic

FUSIBLE RES .... Fusible

R001	401 026 4308	CARBON	3.3K JA	1/6W
R002	401 026 4308	CARBON	3.3K JA	1/6W
R005	401 026 9907	CARBON	4.7K JA	1/6W
R006	401 026 9907	CARBON	4.7K JA	1/6W
R007	401 027 2303	CARBON	560 JA	1/6W
R008	401 027 2303	CARBON	560 JA	1/6W
★R009	401 015 6603	CARBON	2.2 JB	1/4W
★R010	401 015 6603	CARBON	2.2 JB	1/4W
R011	401 026 0607	CARBON	270 JA	1/6W
R012	401 027 2600	CARBON	5.6K JA	1/6W

Schematic Location	Part No.	Description	Schematic Location	Part No.	Description
R101	401 010 2501	CARBON 47 JA 1/2W	R461	401 026 0607	CARBON 270 JA 1/6W
R103	401 024 9701	CARBON 12K JA 1/6W	R467	401 010 8305	CARBON 5.6K JA 1/2W
★R104	401 059 2807	OXIDE-MT 150 JA 1W	R468	401 027 5205	CARBON 680 JA 1/6W
R106	401 010 0309	CARBON 39K JA 1/2W	R471	401 027 5205	CARBON 680 JA 1/6W
R107	401 009 4806	CARBON 33 JA 1/2W	R473	401 027 3003	CARBON 56K JA 1/6W
R111	401 024 9008	CARBON 120 JA 1/6W	R474	401 025 4903	CARBON 180K JA 1/6W
R112	401 024 9008	CARBON 120 JA 1/6W	R475	401 027 5205	CARBON 680 JA 1/6W
R133	401 027 8602	CARBON 8.2K JA 1/6W	★R481	401 009 4905	CARBON 33 JB 1/2W
R141	401 025 1605	CARBON 1.5K JA 1/6W	★R482	401 011 9004	CARBON 1 JB 1/4W
R142	401 024 7707	CARBON 100K JA 1/6W	★R483	401 006 7701	CARBON 1 JB 1/2W
R151	401 025 1308	CARBON 150 JA 1/6W	★R484	401 064 6302	OXIDE-MT 10 JA 2W
R152	401 025 7805	CARBON 2.2K JA 1/6W	R485	401 027 5205	CARBON 680 JA 1/6W
R153	401 024 7400	CARBON 10K JA 1/6W	★R486	401 063 4606	OXIDE-MT 8.2 JA 1W
R155	401 026 1604	CARBON 270K JA 1/6W	R487	401 025 1308	CARBON 150 JA 1/6W
R156	401 026 1604	CARBON 270K JA 1/6W	R488	401 026 6609	CARBON 390 JA 1/6W
R157	401 026 4902	CARBON 330K JA 1/6W	R489	401 027 5007	CARBON 68 JA 1/6W
R159	401 025 7409	CARBON 220 JA 1/6W	R491	401 012 5708	CARBON 1K JA 1/4W
R161	401 026 1604	CARBON 270K JA 1/6W	R492	401 097 3903	MT-FILM 39K FA 1/6W
R162	401 024 7004	CARBON 1K JA 1/6W	R493	401 018 5801	CARBON 330K JA 1/4W
R163	401 024 9008	CARBON 120 JA 1/6W	R494	401 017 3808	CARBON 270K JA 1/4W
R164	401 024 7004	CARBON 1K JA 1/6W	R496	401 024 7707	CARBON 100K JA 1/6W
R202	401 026 0607	CARBON 270 JA 1/6W	★R497	401 057 9907	OXIDE-MT 1.5 JA 1W
R204	401 020 0801	CARBON 470 JA 1/4W	R501	401 024 6700	CARBON 100 JA 1/6W
R205	401 027 5205	CARBON 680 JA 1/6W	R502	401 027 3003	CARBON 56K JA 1/6W
R212	401 025 3807	CARBON 180 JA 1/6W	R503	401 026 1307	CARBON 27K JA 1/6W
R213	401 025 7409	CARBON 220 JA 1/6W	R504	401 026 4308	CARBON 3.3K JA 1/6W
R216	401 024 8001	CARBON 1M JA 1/6W	R506	401 024 7004	CARBON 1K JA 1/6W
R217	401 024 8001	CARBON 1M JA 1/6W	R507	401 006 8104	CARBON 1.2 JA 1/2W
R251	401 024 7400	CARBON 10K JA 1/6W	R508	401 022 3107	CARBON 6.8K JA 1/4W
R252	401 027 8602	CARBON 8.2K JA 1/6W	R509	401 025 4200	CARBON 1.8K JA 1/6W
R271	401 024 6700	CARBON 100 JA 1/6W	★R511	401 060 2704	OXIDE-MT 220 JA 1W
R272	401 024 6700	CARBON 100 JA 1/6W	★R601	402 057 5104	WIRE WOUND 1 KA 8W
R273	401 024 6700	CARBON 100 JA 1/6W	★R602	402 000 0705	SOLID 3.3M KA 1/2W
R281	401 024 6700	CARBON 100 JA 1/6W	R603	401 007 5805	CARBON 120K JA 1/2W
R282	401 027 2303	CARBON 560 JA 1/6W	★R604	401 068 6209	OXIDE-MT 5.6 JA 2W
R304	401 027 3003	CARBON 56K JA 1/6W	★R613	401 068 6902	OXIDE-MT 56 JA 2W
R305	401 027 2303	CARBON 560 JA 1/6W	R614	401 011 1107	CARBON 68 JA 1/2W
R308	401 025 7805	CARBON 2.2K JA 1/6W	R615	401 014 5201	CARBON 15K JA 1/4W
R309	401 026 0607	CARBON 270 JA 1/6W	R616	401 026 4209	CARBON 3.3K GA 1/6W
R310	401 024 7004	CARBON 1K JA 1/6W	R617	401 024 6908	CARBON 1K GA 1/6W
R311	401 026 0607	CARBON 270 JA 1/6W	★R618	401 068 6902	OXIDE-MT 56 JA 2W
R312	401 024 7004	CARBON 1K JA 1/6W	R619	401 025 8208	CARBON 22K JA 1/6W
R313	401 024 7004	CARBON 1K JA 1/6W	R620	401 027 2600	CARBON 5.6K JA 1/6W
R351	401 026 9600	CARBON 470 JA 1/6W	R622	401 026 5701	CARBON 3.6K GA 1/6W
R352	401 026 4902	CARBON 330K JA 1/6W	★R623	401 067 4206	OXIDE-MT 33 JA 2W
R354	401 024 9701	CARBON 12K JA 1/6W	R624	401 025 1605	CARBON 1.5K JA 1/6W
R355	401 026 4308	CARBON 3.3K JA 1/6W	R625	401 008 0908	CARBON 180 JA 1/2W
R358	401 026 4605	CARBON 33K JA 1/6W	★R626	401 066 9103	OXIDE-MT 27 JA 2W
R361	401 024 7400	CARBON 10K JA 1/6W	R630	401 010 4307	CARBON 47K JA 1/2W
R363	401 027 2600	CARBON 5.6K JA 1/6W	R681	401 012 4503	CARBON 100 JA 1/4W
R371	401 026 4605	CARBON 33K JA 1/6W	R682	401 026 4308	CARBON 3.3K JA 1/6W
R372	401 024 7400	CARBON 10K JA 1/6W	R683	401 026 4308	CARBON 3.3K JA 1/6W
R373	401 024 7707	CARBON 100K JA 1/6W	R684	401 026 1000	CARBON 2.7K JA 1/6W
R374	401 027 3003	CARBON 56K JA 1/6W	R703	401 024 6700	CARBON 100 JA 1/6W
R375	401 024 7400	CARBON 10K JA 1/6W	R706	401 024 6700	CARBON 100 JA 1/6W
R401	401 021 1906	CARBON 560 JA 1/4W	R707	401 027 8107	CARBON 82 JA 1/6W
R403	401 025 7805	CARBON 2.2K JA 1/6W	R710	401 024 6700	CARBON 100 JA 1/6W
R404	401 026 3905	CARBON 330 JA 1/6W	★R711	401 065 4604	OXIDE-MT 12K JA 2W
R406	401 010 8305	CARBON 5.6K JA 1/2W	★R712	401 065 4604	OXIDE-MT 12K JA 2W
★R407	401 068 4700	OXIDE-MT 4.7K JA 2W	★R713	401 065 4604	OXIDE-MT 12K JA 2W
★R413	402 057 9706	WIRE WOUND 4.7 KA 6W	R715	401 009 1508	CARBON 2.7K JA 1/2W
★R418	401 009 1607	CARBON 2.7K JB 1/2W	R716	401 009 1508	CARBON 2.7K JA 1/2W
★R421	401 148 7201	MT-FILM 1.8K FA 1/6W	R717	401 009 1508	CARBON 2.7K JA 1/2W
★R422	401 052 6802	MT-FILM 10K FA 1/6W	R804	401 024 7400	CARBON 10K JA 1/6W
★R423	401 053 2605	MT-FILM 3.3K FA 1/6W	R807	401 024 7400	CARBON 10K JA 1/6W
R426	401 027 5205	CARBON 680 JA 1/6W	R808	401 024 7400	CARBON 10K JA 1/6W
R428	401 025 1902	CARBON 15K JA 1/6W	R811	401 024 7400	CARBON 10K JA 1/6W
R460	401 026 3905	CARBON 330 JA 1/6W	R813	401 024 7400	CARBON 10K JA 1/6W



Schematic Location	Part No.	Description	Schematic Location	Part No.	Description
VR3406	645 006 2421	VR B-20K (VCO)			
	645 006 5132	VR B-20K			
VR3411	645 006 2476	VR B-5K (HI-SEP.)			
	645 006 5200	VR B-5K			
VR3421	645 001 9319	VR B-10K (LOW-SEP.)			
	645 006 5095	VR B-10K			

### FILTERS/CRYSTALS

X141	421 001 9104	SAW F TSF1228L
X153	610 015 2946	CERAMIC FILTER 4.5MHZ
X161	610 015 3059	TRAP, CERAMIC 4.5MHZ
	610 015 3066	CERAMIC TRAP
X251	610 012 0655	CRYSTAL OSCILLATOR
	610 204 4195	CRYSTAL OSCILLATOR
	610 245 9746	CRYSTAL OSCILLATOR
X401	610 012 2970	OSC, CERAMIC 503.5KHZ
	645 003 4107	OSC, CERAMIC 503KHZ
X801	645 000 5299	OSC, CERAMIC 12.0MHZ

### MISCELLANEOUS

A100	610 260 1992	ASSY, PWB, MAIN
★A101	645 012 2156	TUNER, U/V
A102	610 246 9660	HOLDER ANT A-VC
A102B	610 011 8492	CABLE
	610 245 2716	CABLE
A102C	412 018 8402	SCREW 3X10E
A700	610 249 5119	ASSY, PWB, SOCKET
A1000	610 258 4080	ASSY, PWB, AV
A1901	645 007 1546	UNIT, RC RECEIVER
A9901	610 259 4423	ASSY, PWB, RC-PWB UNIT
★F601	423 007 1601	FUSE 125V 4A
	423 007 1809	FUSE 125V 4A
	423 018 8101	FUSE 125V 4A
F601A	610 012 4356	FUSE CLIP
	645 006 4760	HOLDER, FUSE
F601B	610 012 4356	FUSE CLIP
	645 006 4760	HOLDER, FUSE
★K701	610 010 4181	CRT SOCKET
K1001	610 010 3689	JACK, RCA
K1002	610 010 3665	JACK, RCA
K1003	610 010 3672	JACK, RCA
K1011	610 010 3665	JACK, RCA
K1021	610 010 3672	JACK, RCA
★PS601	408 002 5205	TH PTH451C260BF5ROM140
★Q900	414 008 3800	CRT M78JUA069X71
★RL601	645 000 4155	RELAY (POWER OFF/ON)
	645 011 2713	RELAY
	645 015 8629	RELAY
SP901	645 013 6306	SPEAKER, 8
SP902	645 013 6306	SPEAKER, 8
★W601	645 014 2444	CORD, POWER
★W900	610 236 0509	(MEX)GND CONNECTOR

# CABINET PARTS LIST

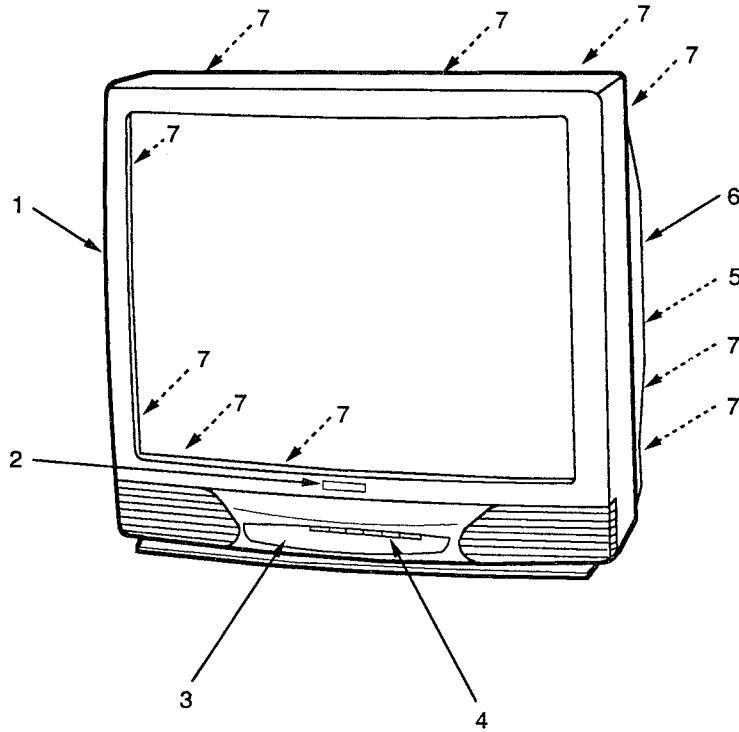

## CABINET PARTS LIST

## ACCESSORY PARTS LIST

KEY NO.	PARTS NO.	DESCRIPTION
1.	610 257 8645	CABINET FRONT
2.	610 236 9274	SANYO BADGE
3.	610 257 8799	DEC SHEET
4.	610 245 5816	BUTTON UNITED
	411 078 1101	SCREW 4X14(3 USED)
OR	412 036 1805	SCREW
5.	610 258 7968	DEC AV SHEET
6.	610 257 8911	CABINET BACK
	411 078 1101	SCREW 4X14(11 USED)
OR	412 036 1805	SCREW
	412 009 6301	SCREW 4X12E(2 USED)
7.	610 261 4220	CABLE CLIP (10 USED FOR MTG D-COIL)
	412 000 7505	SCREW 6X30E(4 USED FOR MTG CRT)
OR	412 032 0406	SCREW
OR	412 053 3905	SCREW
OR	412 053 4001	SCREW
OR	412 054 0002	SCREW
OR	412 054 0101	SCREW
	412 051 7806	WASHER(4 USED FOR MTG CRT)
	411 078 1101	SCREW 4X14 (8 USED FOR MTG SPEAKERS)
OR	412 036 1805	SCREW

KEY NO.	PARTS NO.	DESCRIPTION
	645 014 5346	ASSY, RC TRANSMITTER
	610 259 4522	RC-BATTERY COVER
	610 258 3243	OWNER'S MANUAL

# COMPONENT AND TESTPOINT LOCATIONS

## CAUTION

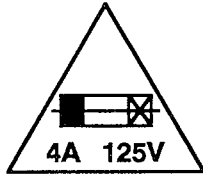

FOR CONTINUED PROTECTION AGAINST A RISK OF FIRE, REPLACE ONLY WITH THE SAME TYPE 4A, 125V FUSE.  
 ATTENTION : POUR MAINTENIR LA PROTECTION CONTRE LES RISQUES D'INCENDIE UTILISER UN FUSIBLE DE RECHANGE DE MEME TYPE 4A, 125V.

## MAIN BOARD

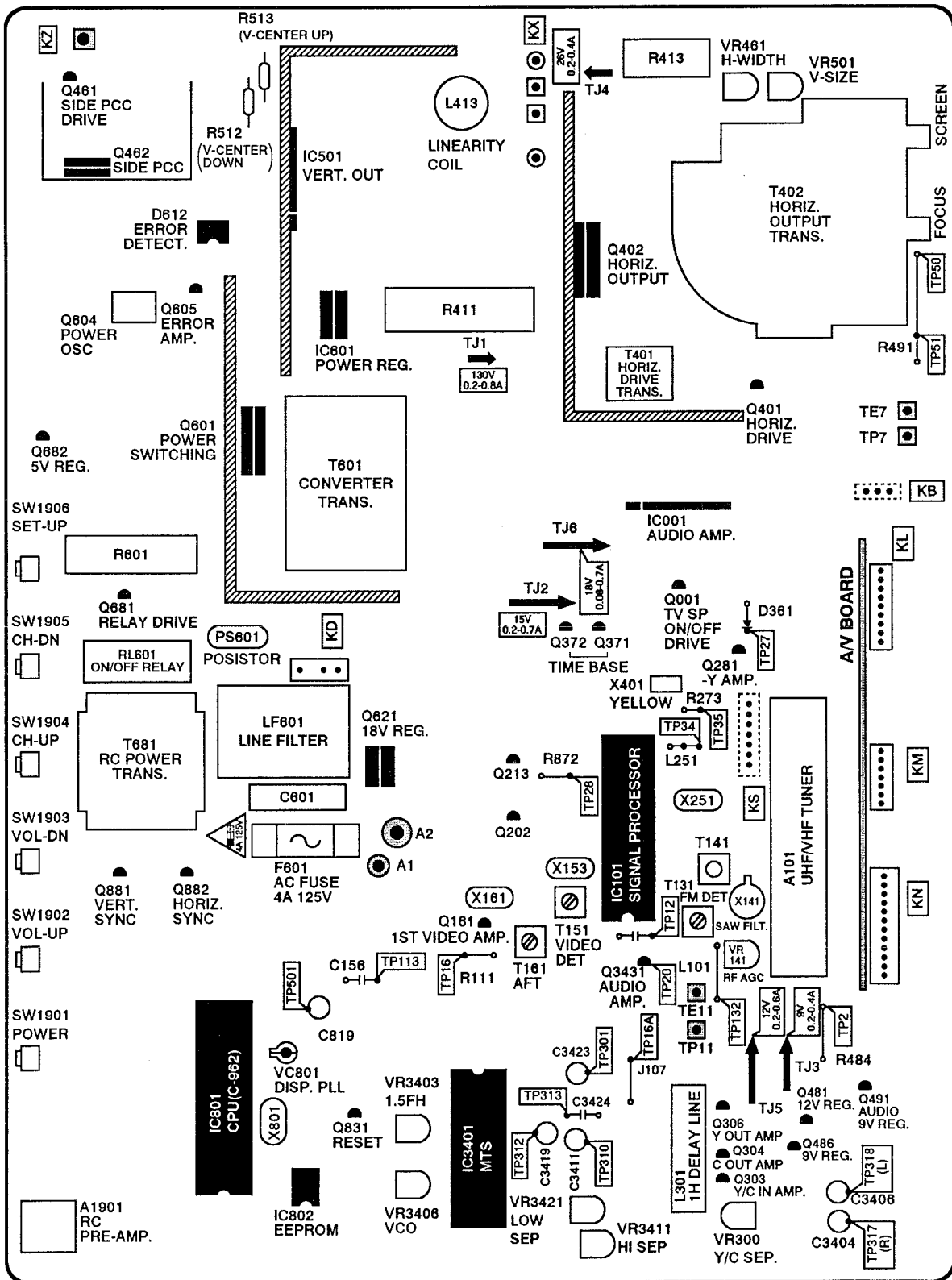

## A/V BOARD

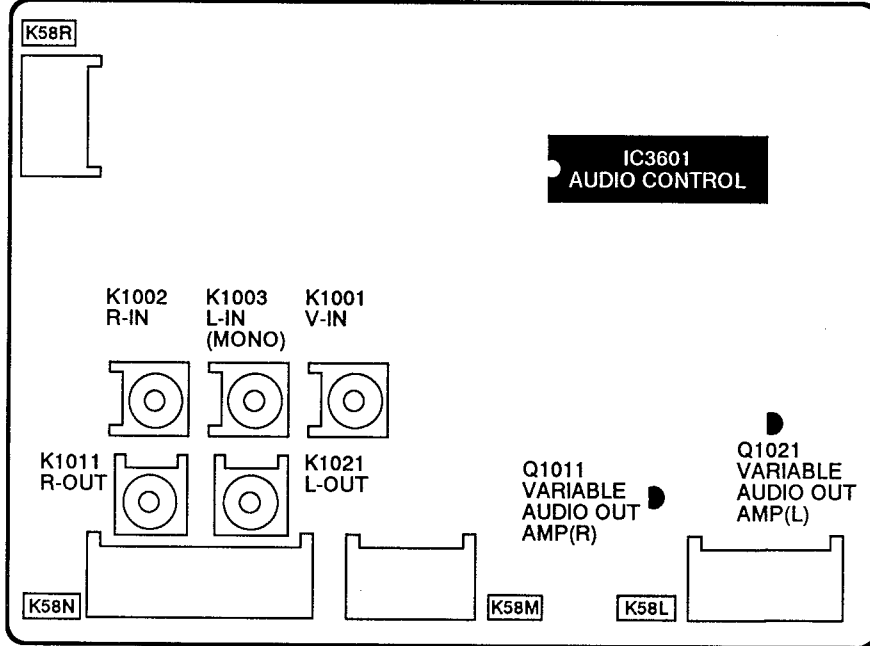

## PIX TUBE SOCKET BOARD

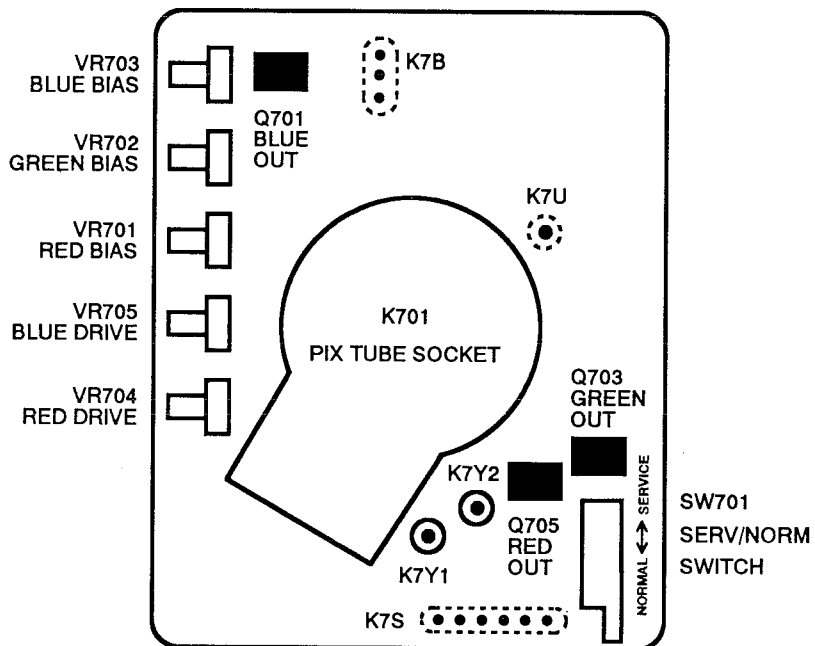



## CAPACITOR AND RESISTOR CODE CHART

### CAPACITOR (Example)

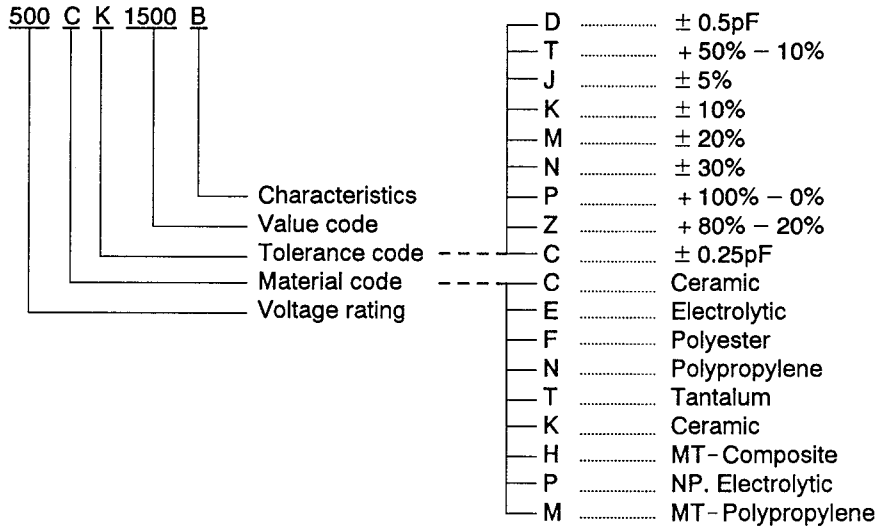

### RESISTOR (Example)

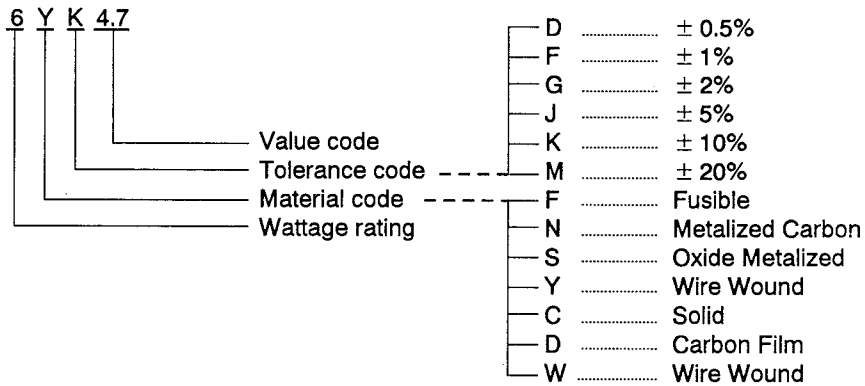



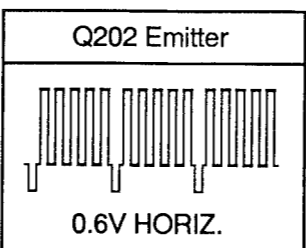
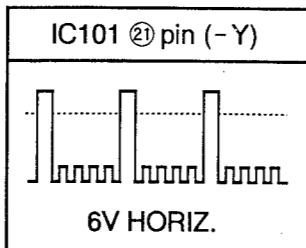
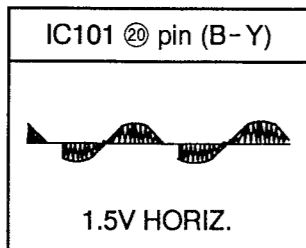
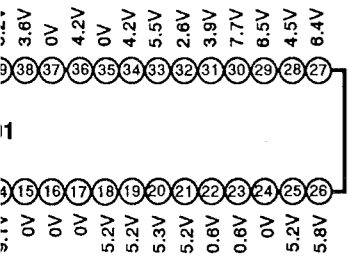

Q161	
VOLT.	
B	3.0V
C	0V
E	3.7V

Q213	
VOLT.	
B	3.6V
C	0V
E	4.3V

Q481	
VOLT.	
B	12.5V
C	11.9V
E	11.8V

Q491	
VOLT.	
B	9.6V
C	9.7V
E	8.9V

Q3431	
VOLT.	
B	3.4V
C	9.1V
E	2.8V

Q202	
VOLT.	
B	3.6V
C	0V
E	4.3V

Q486	
VOLT.	
B	9.8V
C	10.1V
E	9.1V

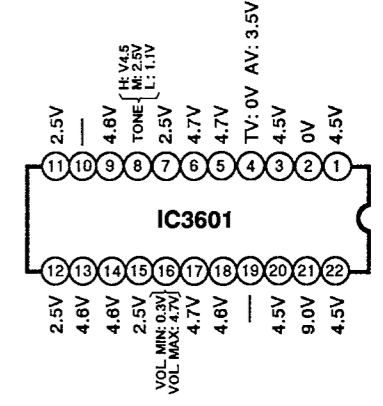
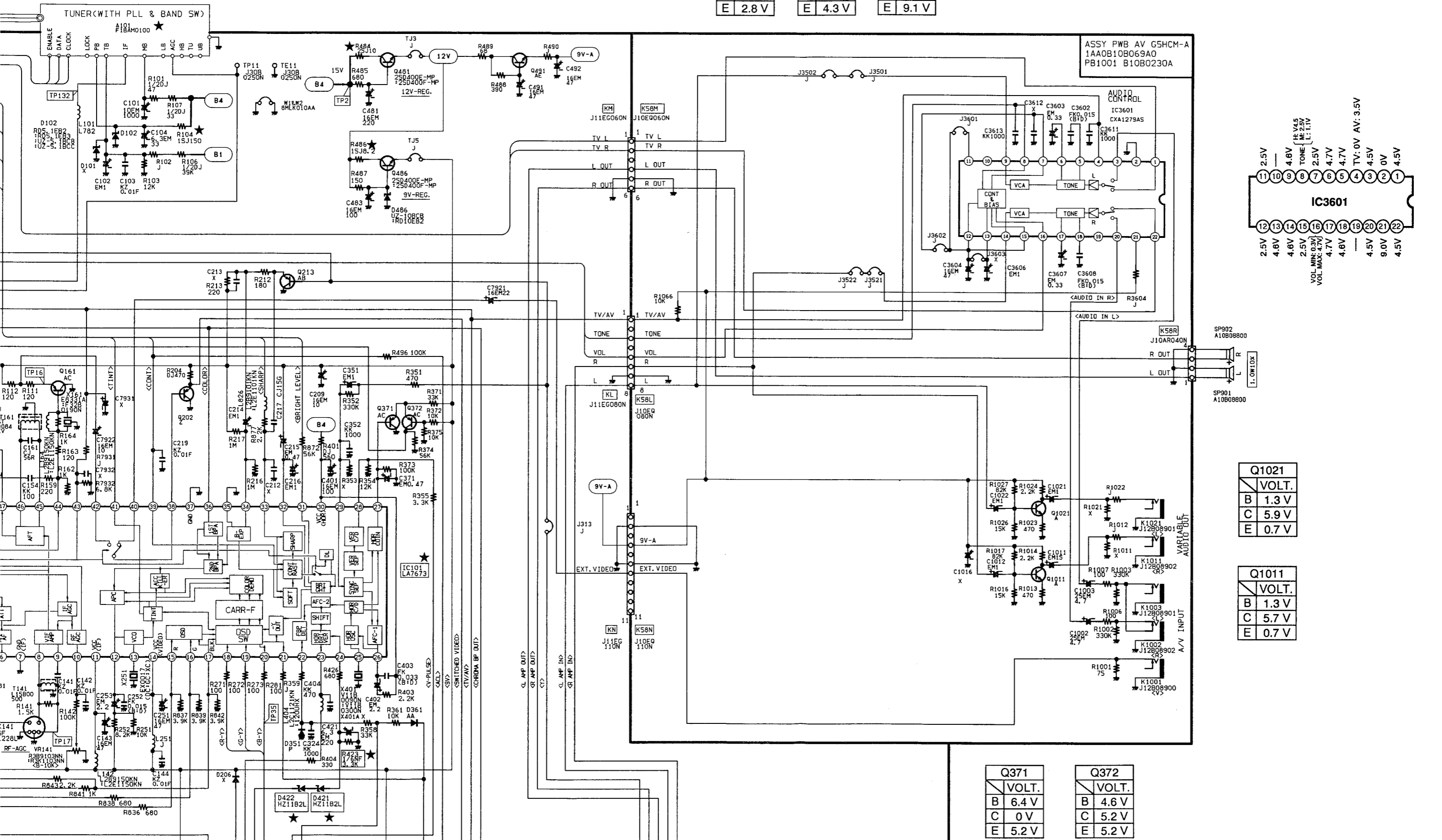

Q1021	
VOLT.	
B	1.3V
C	5.9V
E	0.7V

Q1011	
VOLT.	
B	1.3V
C	5.7V
E	0.7V

Q371	
VOLT.	
B	6.4V
C	0V
E	5.2V

Q372	
VOLT.	
B	4.6V
C	5.2V
E	5.2V

R304 56K D201 AA

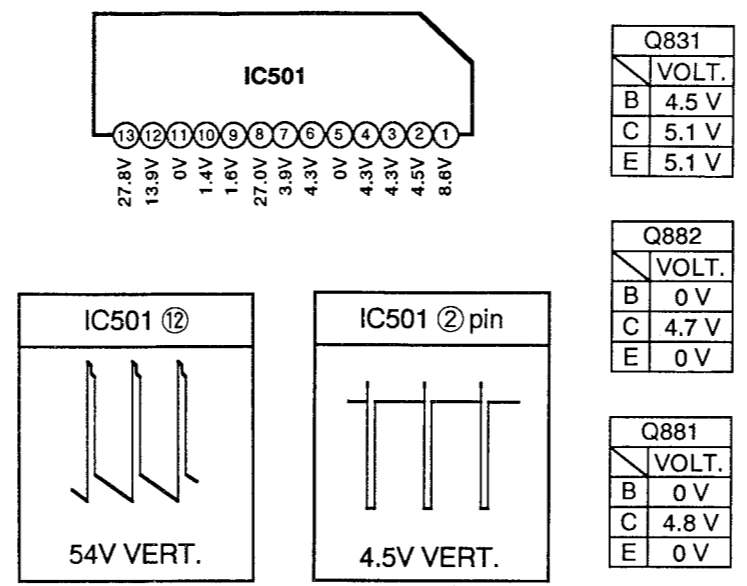
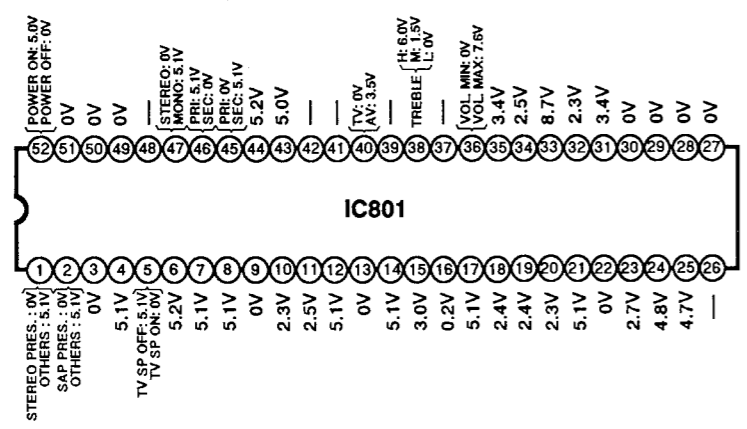
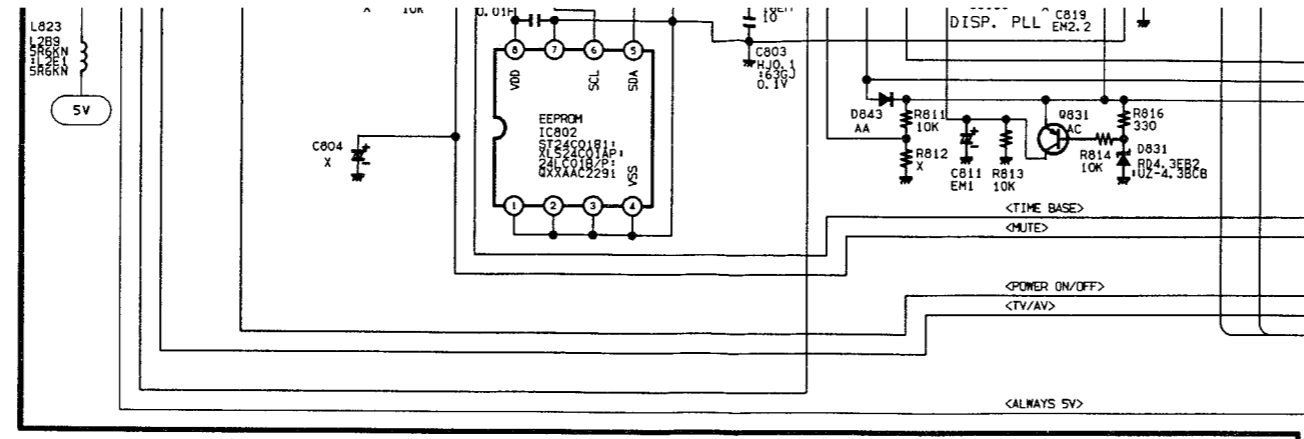
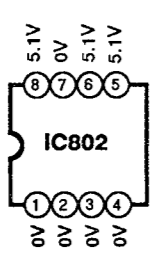

Q701	VOLT.
B	5.3 V
C	193.8 V
E	5.3 V

Q703	VOLT.
B	5.2 V
C	199.1 V
E	5.3 V

Q705	VOLT.
B	5.2 V
C	195.8 V
E	5.4 V

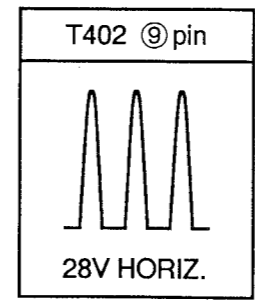
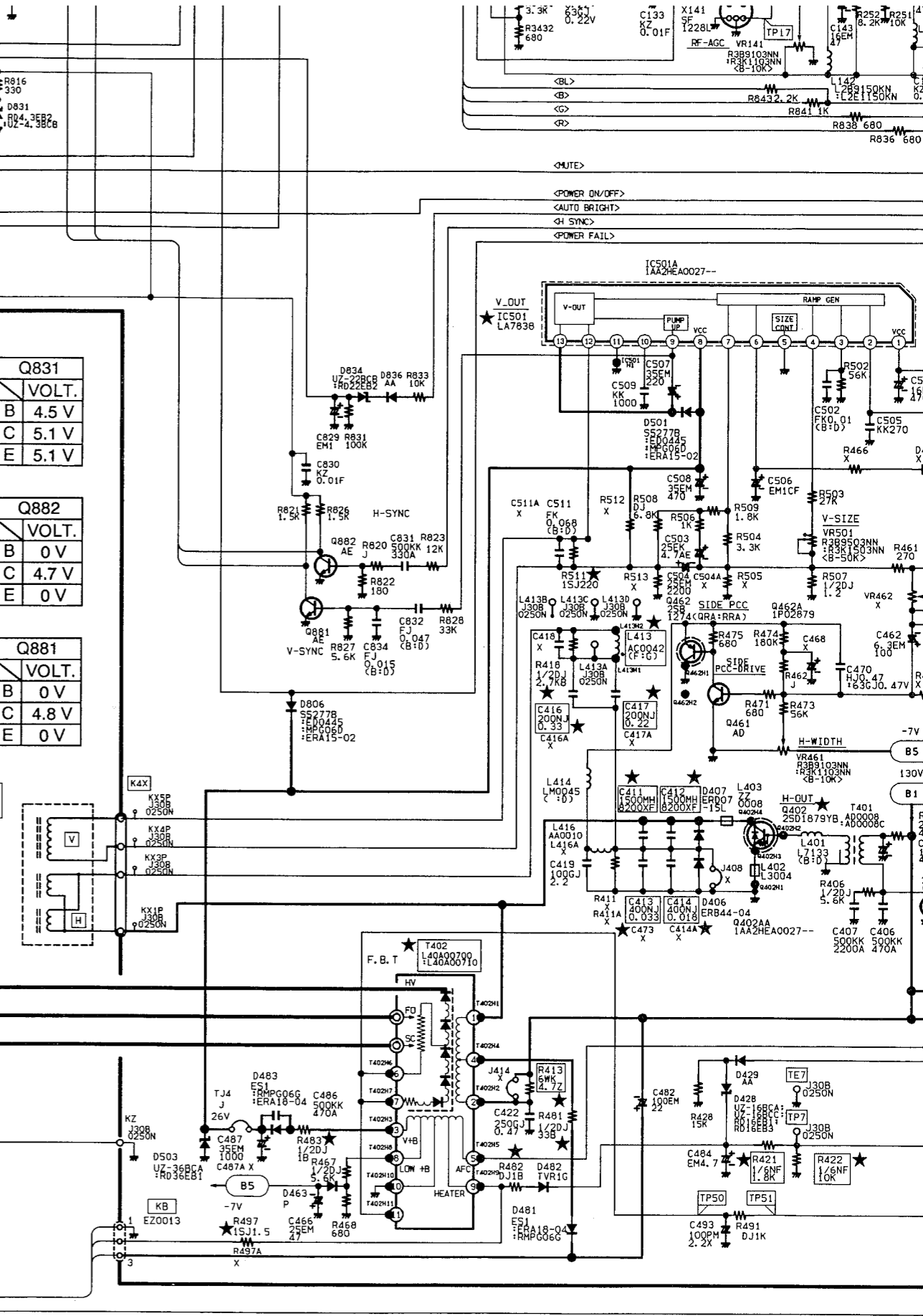
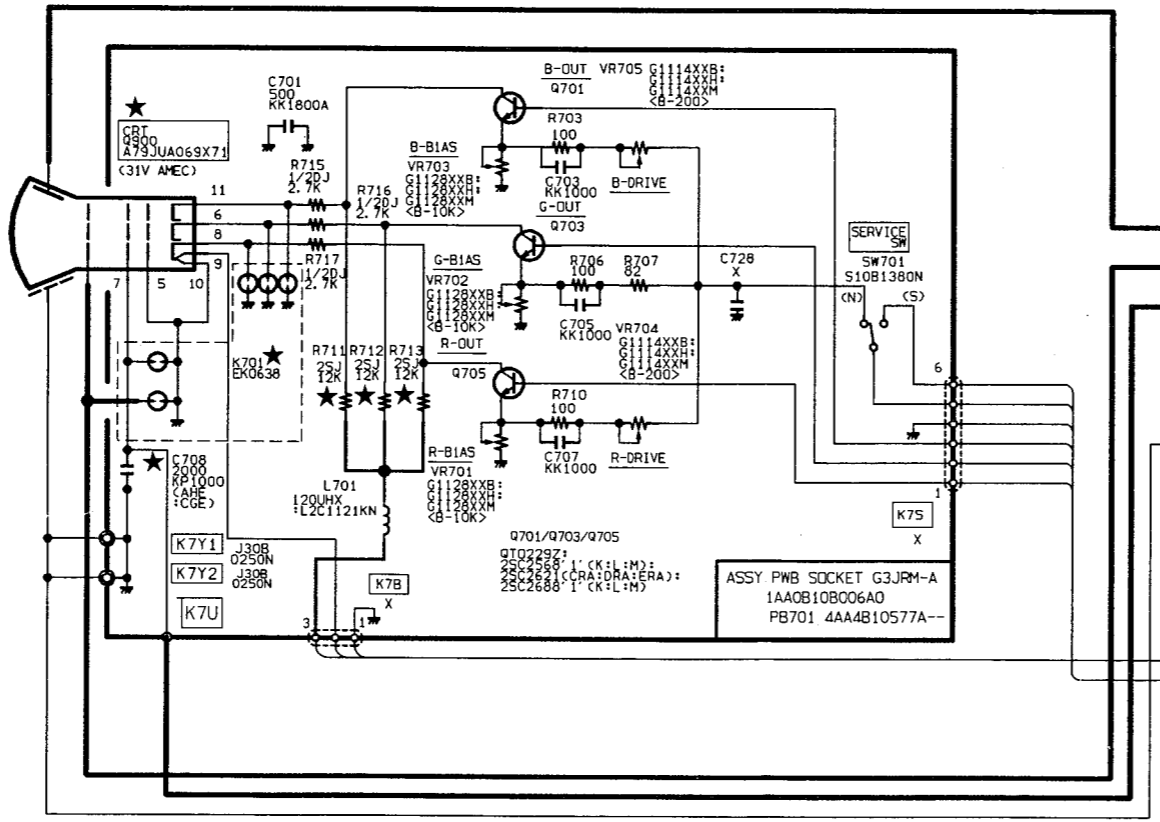

Q462	VOLT.
B	17.0 V
C	0 V
E	17.6 V

Q461	VOLT.
B	0.6 V
C	17.0 V
E	0 V

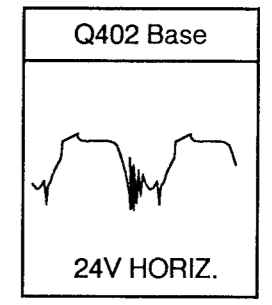

Q402	VOLT.
B	0.2 V
C	0 V
E	0 V

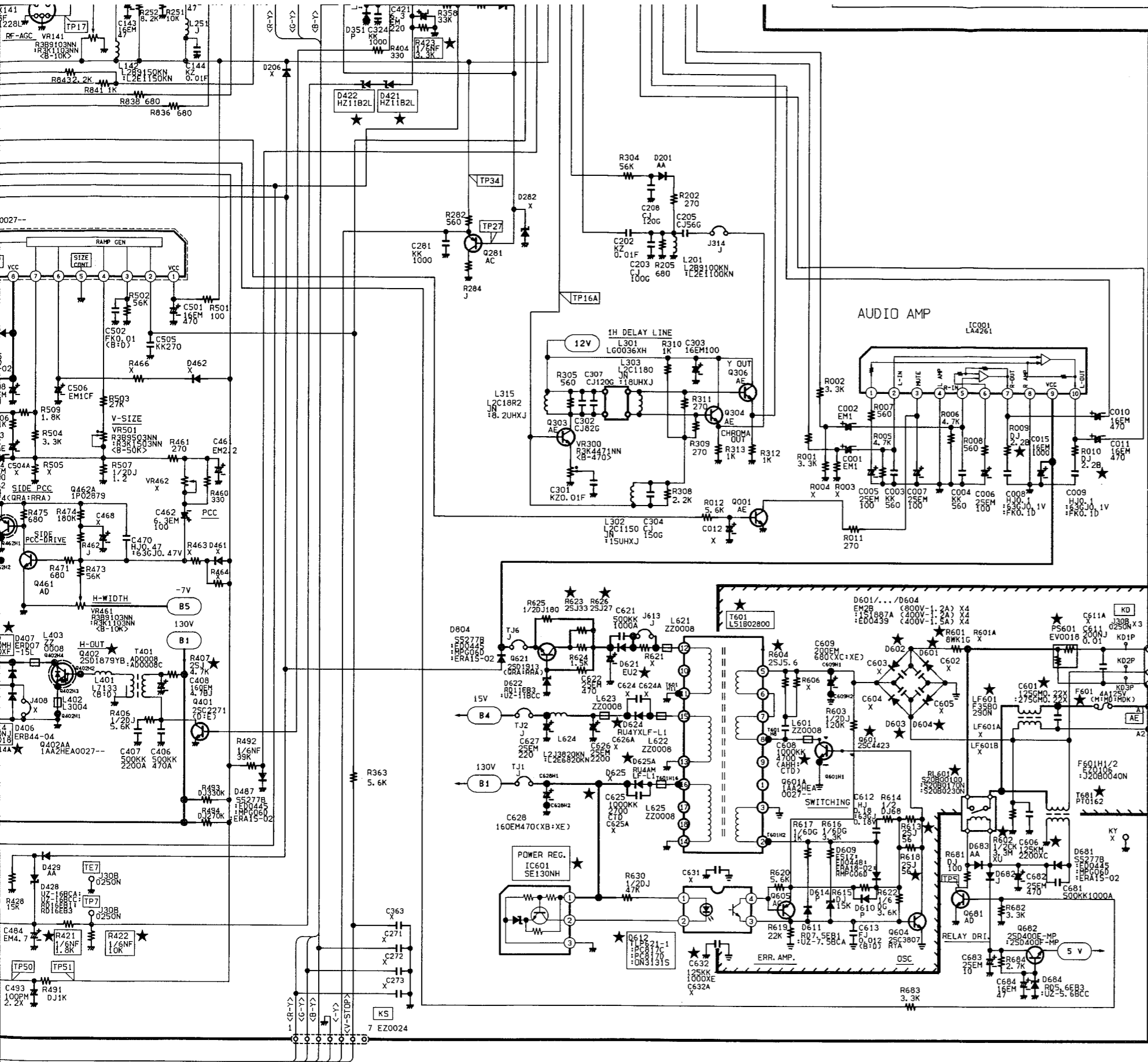

Q371	
VOLT.	
B	6.4 V
C	0 V
E	5.2 V

Q372	
VOLT.	
B	4.6 V
C	5.2 V
E	5.2 V

Q281	
VOLT.	
B	5.3 V
C	0 V
E	5.3 V

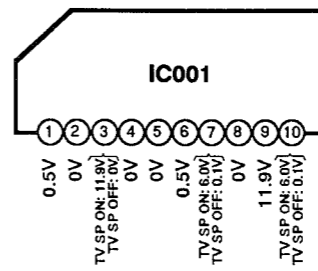

Q001		
TV SP ON		TV SP OFF
B	0 V	0.7 V
C	11.9 V	0 V
E	0 V	0 V

Q303	
VOLT.	
B	4.3 V
C	11.8 V
E	3.6 V

Q304	
VOLT.	
B	4.3 V
C	11.8 V
E	3.6 V

Q306	
VOLT.	
B	4.3 V
C	11.8 V
E	3.6 V

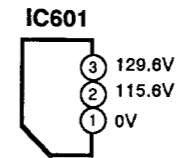

Q601	
VOLT.	
B	-1.2 V
C	161.0 V
E	0 V

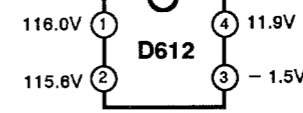

Q681		
POWER ON	POWER OFF	
B	0.7 V	0 V
C	0.1 V	18.3 V
E	0 V	0 V

Q682		
POWER ON	POWER OFF	
B	5.8 V	5.8 V
C	15.9 V	18.2 V
E	5.2 V	5.2 V

Q604	
VOLT.	
B	-1.5 V
C	-1.2 V
E	0 V



Q402	
VOLT.	
B	0.2 V
C	0 V
E	0 V

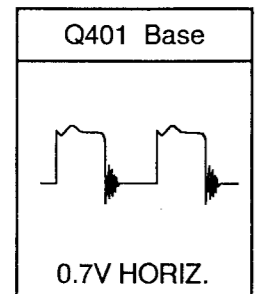

Q401	
VOLT.	
B	0.4 V
C	46.5 V
E	0 V

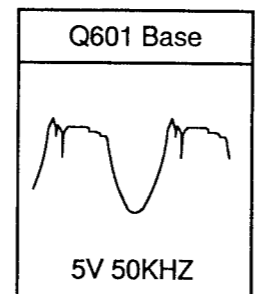

Q621	
VOLT.	
B	11.3 V
C	17.9 V
E	11.9 V

Q605	
VOLT.	
B	11.9 V
C	-1.5 V
E	12.4 V

