

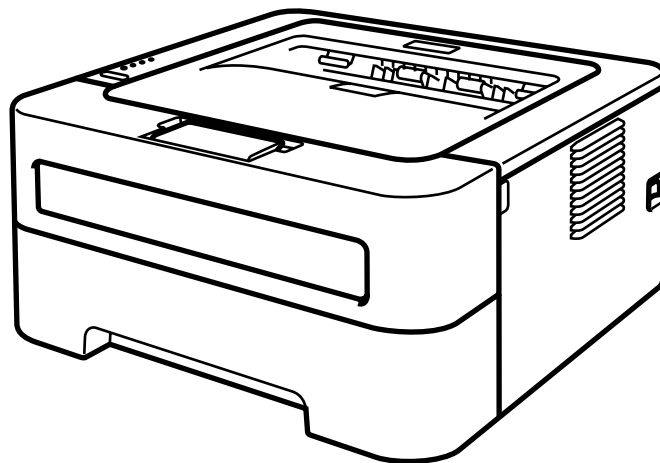


# Brother Laser Printer **SERVICE MANUAL**

---

---

**MODEL:  
HL-2130/2220/2230/2240/  
2240D/2250DN/2270DW**



Read this manual thoroughly before maintenance work.  
Keep this manual in a convenient place for quick and easy reference at all times.

September 2010  
SM-PRN079  
84UC0\*  
(3)

The function comparative table for models as described in this Service Manual are shown below.

Model	HL-2130	HL-2220	HL-2230	HL-2240	HL-2240D	HL-2250DN	HL-2270DW
LAN	No	No	No	No	No	Wired	Wired/ Wireless
Paper edge sensor	No	No	No	No	No	Yes	Yes
Duplex printing	No	No	No	No	Yes	Yes	Yes
Manual paper tray cover	No	No	Yes	Yes	Yes	Yes	Yes

© Copyright Brother Industries, Ltd. 2010

Compilation and Publication:

This manual has been compiled and published, under the supervision of Brother Industries Ltd., covering the latest product descriptions and specifications. The contents of this manual and the specifications of this product are subject to change without notice. Brother reserves the right to make changes without notice in the specifications and materials contained herein and shall not be responsible for any damages (including consequential) caused by reliance on the materials presented, including but not limited to typographical and other errors relating to the publication. This product is designed for use in a professional environment.

# TABLE OF CONTENTS

<b>REGULATION</b> .....	<b>vi</b>
<b>SAFETY INFORMATION</b> .....	<b>x</b>
<b>CHAPTER 1 SPECIFICATIONS</b> .....	<b>1-1</b>
<b>1. SPECIFICATIONS LIST</b> .....	<b>1-1</b>
1.1 General .....	1-1
1.2 Network Connectivity .....	1-4
1.3 Service Information .....	1-5
1.4 Supplies .....	1-6
1.5 Paper .....	1-7
1.5.1 Paper handling .....	1-7
1.5.2 Media specifications .....	1-7
1.6 Printable Area .....	1-8
<b>CHAPTER 2 TROUBLESHOOTING</b> .....	<b>2-1</b>
<b>1. INTRODUCTION</b> .....	<b>2-1</b>
1.1 Precautions .....	2-1
1.2 Initial Check .....	2-2
<b>2. OVERVIEW</b> .....	<b>2-4</b>
2.1 Cross-section Drawing .....	2-4
2.2 Paper Feeding .....	2-5
2.3 Operation of each part .....	2-6
2.4 Block Diagram .....	2-7
2.5 Components .....	2-8
<b>3. LED ERROR INDICATION AND FAILURES</b> .....	<b>2-9</b>
3.1 LED indication at Operator Calls .....	2-9
3.2 LED indication at Service Calls .....	2-12
3.3 Error messages in the Status Monitor .....	2-17
3.4 Error indication at Service Calls .....	2-18
3.5 Image Defect Examples .....	2-20
<b>4. ERROR SYMPTOM/ERROR CAUSE AND REMEDY</b> .....	<b>2-21</b>
4.1 Paper Feeding Problems .....	2-21
4.1.1 Pickup function of Paper tray does not work. ....	2-21
4.1.2 No feeding .....	2-21
4.1.3 No paper fed manual feed slot .....	2-22
4.1.4 Double feeding .....	2-22
4.1.5 Paper jam .....	2-23

4.1.6	Dirt on paper .....	2-25
4.1.7	Paper feeding at an angle .....	2-25
4.1.8	Wrinkles or creases .....	2-26
4.1.9	Curl in the paper .....	2-27
4.1.10	Prints only single side of the paper when duplex-printing .....	2-28
4.1.11	Cannot make print through duplex-printing .....	2-28
4.1.12	Paper size error .....	2-28
4.1.13	Paper size error through duplex-printing .....	2-28
4.2	Troubleshooting Image Defect .....	2-29
4.2.1	Light .....	2-29
4.2.2	Faulty registration .....	2-31
4.2.3	Dark .....	2-31
4.2.4	Poor fixing .....	2-32
4.2.5	Completely blank .....	2-32
4.2.6	Image distortion .....	2-33
4.2.7	All black .....	2-33
4.2.8	The back of paper gets dirty .....	2-33
4.2.9	Vertical streaks .....	2-34
4.2.10	Black vertical streaks in a light background .....	2-34
4.2.11	Black horizontal stripes .....	2-35
4.2.12	White vertical streaks .....	2-36
4.2.13	White horizontal streaks .....	2-36
4.2.14	Faint print .....	2-36
4.2.15	White spots .....	2-37
4.2.16	Black spots .....	2-37
4.2.17	Black band .....	2-38
4.2.18	Downward fogging of solid black .....	2-38
4.2.19	Horizontal lines .....	2-38
4.2.20	Ghost .....	2-39
4.2.21	Fogging .....	2-39
4.3	Software Setting Problems .....	2-40
4.3.1	Cannot print data .....	2-40
4.4	Network Problems (Network model only) .....	2-41
4.4.1	Cannot make a print through network connection .....	2-41
4.5	Toner & Drum Problems .....	2-42
4.5.1	If replace toner, cannot delete "Replace Toner". .....	2-42
4.5.2	Cannot detect toner .....	2-42
4.5.3	Toner low .....	2-42
4.5.4	Replace toner .....	2-42
4.5.5	The number of rotations of the developer roller reaches the upper limit .....	2-43
4.5.6	No toner .....	2-43
4.5.7	Drum life end soon .....	2-43
4.5.8	Drum error .....	2-43
4.5.9	Drum stop .....	2-43
4.6	Fuser Unit Problems .....	2-44
4.6.1	Fuser Unit failure .....	2-44

4.7	Laser Unit Problems .....	2-44
4.7.1	Laser Unit failure .....	2-44
4.8	PCB Problems .....	2-45
4.8.1	Main PCB failure .....	2-45
4.8.2	Memory full .....	2-45
4.8.3	Print overrun .....	2-45
4.8.4	High voltage power supply PCB ASSY failure .....	2-45
4.8.5	Low voltage power supply PCB ASSY failure .....	2-46
4.9	Other Problems .....	2-46
4.9.1	The printer is not turned on, or the LED indication does not appear. ....	2-46
4.9.2	Fuser fan does not rotate. ....	2-46
4.9.3	Main motor failure .....	2-47
4.9.4	Front cover open .....	2-47
4.9.5	Back cover open .....	2-47

## **CHAPTER 3 DISASSEMBLY AND ASSEMBLY ..... 3-1**

<b>1.</b>	<b>SAFETY PRECAUTIONS .....</b>	<b>3-1</b>
<b>2.</b>	<b>PACKING .....</b>	<b>3-2</b>
<b>3.</b>	<b>SCREW CATALOGUE .....</b>	<b>3-3</b>
<b>4.</b>	<b>SCREW TORQUE LIST .....</b>	<b>3-4</b>
<b>5.</b>	<b>LUBRICATION .....</b>	<b>3-5</b>
<b>6.</b>	<b>OVERVIEW OF GEARS .....</b>	<b>3-6</b>
<b>7.</b>	<b>HARNES ROUTING .....</b>	<b>3-9</b>
<b>8.</b>	<b>DISASSEMBLY FLOW .....</b>	<b>3-17</b>
<b>9.</b>	<b>DISASSEMBLY PROCEDURE .....</b>	<b>3-18</b>
9.1	Paper Tray .....	3-19
9.2	Back Cover .....	3-22
9.3	Outer Chute ASSY .....	3-24
9.4	Fuser Cover .....	3-25
9.5	Inner Chute ASSY, Eject Pinch Roller R ASSY and Eject Pinch Roller L ASSY .....	3-26
9.6	Front Cover ASSY, Support Flap 1 .....	3-28
9.7	Side Cover L .....	3-29
9.8	Side Cover R .....	3-30
9.9	Top Cover ASSY .....	3-31
9.10	Fuser Unit .....	3-35
9.11	Low voltage power supply PCB ASSY .....	3-38
9.12	Fuser fan .....	3-41
9.13	High voltage power supply PCB ASSY .....	3-42
9.14	Panel PCB ASSY .....	3-43
9.15	Filter .....	3-44

9.16 Laser Unit .....	3-45
9.17 Wireless LAN PCB ASSY (Wireless network model only) .....	3-47
9.18 Pick-up Roller Holder ASSY .....	3-48
9.19 Rubber Foot .....	3-49
9.20 Main PCB ASSY .....	3-50
9.21 T1 Clutch ASSY, REG Clutch ASSY .....	3-51
9.22 Main Frame L ASSY .....	3-53
9.23 Develop Drive Sub ASSY, Develop Gear Joint/52 .....	3-55
9.24 Motor Drive Sub ASSY, Main Motor .....	3-57
9.25 Paper Eject Sensor PCB ASSY .....	3-59
9.26 Fuser Gear 28/34 .....	3-61

## **CHAPTER 4 ADJUSTMENTS AND UPDATING OF SETTINGS, REQUIRED AFTER PARTS REPLACEMENT ..... 4-1**

<b>1. IF YOU REPLACE THE MAIN PCB ASSY .....</b>	<b>4-1</b>
1.1 Rewriting the Firmware (Main Program) .....	4-2
1.1.1 Checking firmware version .....	4-2
1.1.2 Rewriting the firmware .....	4-2
1.2 Setting the default paper size .....	4-3
1.3 Setting the serial number .....	4-4
1.4 Inputting the adjusted value of the laser unit .....	4-6
<b>2. IF YOU REPLACE THE LASER UNIT .....</b>	<b>4-10</b>
2.1 Inputting the adjusted value of the laser unit .....	4-10
<b>3. IF YOU REPLACE THE LOW VOLTAGE POWER SUPPLY PCB ASSY .....</b>	<b>4-14</b>
3.1 Reset of Irregular Power Supply Detection Counter .....	4-14

## **CHAPTER 5 SERVICE FUNCTIONS ..... 5-1**

<b>1. MAINTENANCE MODE .....</b>	<b>5-2</b>
1.1 How to Enter the End User-accessible Maintenance Mode .....	5-2
1.2 How to Enter the Service Personnel-accessible Maintenance Mode .....	5-2
1.3 List of Maintenance Mode Functions .....	5-3
1.4 Detailed Description of Maintenance-mode Functions .....	5-5
<b>2. PRINTER SETTINGS .....</b>	<b>5-13</b>
2.1 Printout of Printer Settings .....	5-13
<b>3. OTHER SERVICE FUNCTIONS .....</b>	<b>5-20</b>
3.1 Reprint Function .....	5-20
3.2 Job Cancel Function .....	5-20
3.3 Wireless LAN setting (Wireless Network Model only) .....	5-21
3.4 Wireless Connecting Diagnostic Report Print (Wireless Network Model only) .....	5-21
3.5 Continue Mode/Stop Mode settings of Toner Cartridge .....	5-22
3.6 Drum Cleaning Function .....	5-22

<b>CHAPTER 6</b>	<b>CIRCUIT DIAGRAMS, WIRING DIAGRAM .....</b>	<b>6-1</b>
<b>CHAPTER 7</b>	<b>PERIODICAL MAINTENANCE .....</b>	<b>7-1</b>
<b>1.</b>	<b>PERIODICAL PEPLACEMENT PARTS .....</b>	<b>7-1</b>
<b>APPENDIX 1</b>	<b>SERIAL NUMBERING SYSTEM .....</b>	<b>App. 1-1</b>
<b>APPENDIX 2</b>	<b>DELETION OF USER SETTING INFORMATION .....</b>	<b>App. 2-1</b>
<b>APPENDIX 3</b>	<b>INSTALLING THE MAINTENANCE PRINTER DRIVER .....</b>	<b>App. 3-1</b>
<b>APPENDIX 4</b>	<b>HOW TO MAKE PROTECTIVE MATERIAL OF DRUM UNIT .....</b>	<b>App. 4-1</b>

## REGULATION

### <For Europe and Other countries>

#### ■ Radio interference (220 to 240 volt model only)

This printer follows EN55022 (CISPR Publication 22)/Class B.

#### ■ IEC 60825-1: 2007 specification (220 to 240 volt model only)

This printer is a Class 1 laser product as defined in IEC 60825-1: 2007 specifications.  
The label shown below is attached in countries where it is needed.



This printer has a Class 3B laser diode which produces invisible laser radiation in the laser unit. You should not open the laser unit under any circumstances.

#### Caution

Use of controls or adjustments or performance of procedures other than those specified in this manual may result in hazardous radiation exposure.

#### For Finland and Sweden

**LUOKAN 1 LASERLAITE**

**KLASS 1 LASER APPARAT**

#### Varoitus!

Laitteen käyttäminen muulla kuin tässä käyttöohjeessa mainitulla tavalla saattaa altistaa käyttäjän turvallisuusluokan 1 ylittävälle näkymättömälle lasersäteilylle.

#### Varning

Om apparaten används på annat sätt än i denna Bruksanvisning specificerats, kan användaren utsättas för osynlig laserstrålning, som överskrider gränsen för laserklass 1.

■ **Internal laser radiation**

Maximum radiation power: 25 mW  
Wave length: 770 - 800 nm  
Laser class: Class 3B

■ **EU Directive 2002/96/EC and EN50419**

(European Union only)

This equipment is marked with the recycling symbol below. It means that at the end of the life of the equipment you must dispose of it separately at an appropriate collection point and not place it in the normal domestic unsorted waste stream. This will benefit the environment for all. (European Union only)



**<For USA and Canada>**

■ **Federal Communications Commission (FCC) Declaration of Conformity  
(For USA)**

Responsible Party: Brother International Corporation  
100 Somerset Corporate Boulevard  
P.O. Box 6911  
Bridgewater, NJ 08807-0911  
USA  
Telephone: (908) 704-1700

declares, that the products

Product name: Laser Printer HL-2130, HL-2220, HL-2230, HL-2240, HL-2240D,  
HL-2250DN and HL-2270DW

Model number: HL-22

complies with Part 15 of the FCC Rules. Operation is subject to the following two conditions:  
(1) This device may not cause harmful interference, and (2) this device must accept any  
interference received, including interference that may cause undesired operation.

This equipment has been tested and found to comply with the limits for a Class B digital  
device, pursuant to Part 15 of the FCC Rules. These limits are designed to provide  
reasonable protection against harmful interference in a residential installation. This  
equipment generates, uses, and can radiate radio frequency energy and, if not installed and  
used in accordance with the instructions, may cause harmful interference to radio  
communications. However, there is no guarantee that interference will not occur in a  
particular installation. If this equipment does cause harmful interference to radio or television  
reception, which can be determined by turning the equipment off and on, the end user is  
encouraged to try to correct the interference by one or more of the following measures:

- Reorient or relocate the receiving antenna.
- Increase the separation between the equipment and receiver.
- Connect the equipment into an outlet on a circuit different from that to which the receiver is  
connected.
- Consult the dealer or an experienced radio/TV technician for help.

**Important**

A shielded interface cable should be used to ensure compliance with the limits for a Class B  
digital device. Changes or modifications not expressly approved by Brother Industries, Ltd.  
could void the user's authority to operate the equipment.

■ **Industry Canada Compliance Statement (For Canada)**

This Class B digital apparatus complies with Canadian ICES-003.

Cet appareil numérique de la classe B est conforme à la norme NMB-003 du Canada.

■ **Laser Safety (110 to 120 volt model only)**

This printer is certified as a Class 1 laser product under the U.S. Department of Health and Human Services (DHHS) Radiation Performance Standard according to the Radiation Control for Health and Safety Act of 1968. This means that the printer does not produce hazardous laser radiation.

Since radiation emitted inside the printer is completely confined within protective housings and external covers, the laser beam cannot escape from the printer during any phase of user operation.

■ **FDA Regulations (110 to 120 volt model only)**

The U.S. Food and Drug Administration (FDA) has implemented regulations for laser products manufactured on and after August 2, 1976. Compliance is mandatory for products marketed in the United States. The following label on the back of the printer indicates compliance with the FDA regulations and must be attached to laser products marketed in the United States.

MANUFACTURED:

Brother Technology (Shenzhen) Ltd.

NO6 Gold Garden Ind., Nanling Buji, Longgang, Shenzhen, China

This product complies with FDA performance standards for laser products except for deviations pursuant to Laser Notice No.50, dated Jun 24, 2007.

■ **Internal laser radiation**

Maximum radiation power: 25 mW

Wave length: 770 - 800 nm

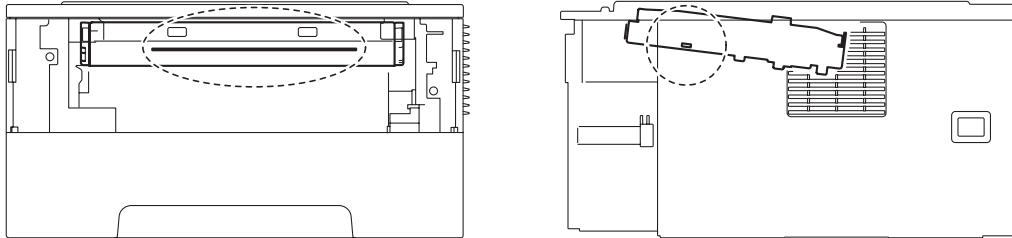
Laser class: Class 3B

## SAFETY INFORMATION

### ■ Caution for Laser Product (WARNHINWEIS für Laser drucker)

- CAUTION:** When the printer during servicing is operated with the cover open, the regulations of VBG 93 and the performance instructions for VBG 93 are valid.
- CAUTION:** In case of any trouble with the laser unit, replace the laser unit itself. To prevent direct exposure to the laser beam, do not try to open the enclosure of the laser unit.
- ACHTUNG:** Im Falle von Störungen der Lasereinheit muß diese ersetzt werden. Das Gehäuse der Lasereinheit darf nicht geöffnet werden, da sonst Laserstrahlen austreten können.

<Location of the laser beam window>



### ■ Additional Information





When servicing the optical system of the printer, be careful not to place a screwdriver or other reflective object in the path of the laser beam. Be sure to take off any personal accessories such as watches and rings before working on the printer. A reflected beam, though invisible, can permanently damage the eyes.

Since the beam is invisible, the following caution label is attached on the laser unit.





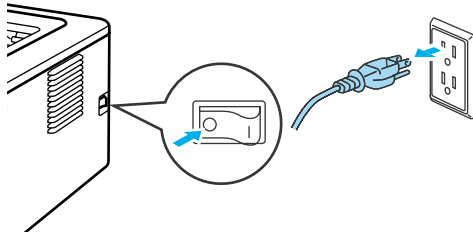

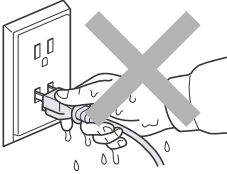

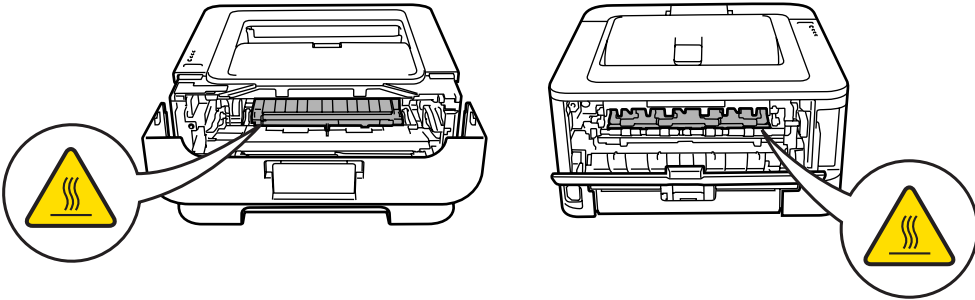
## ■ Definitions of Warnings, Cautions, Notes and Memos

The following conventions are used in this manual:

Mark	Contents
	Warnings tell you what to do to prevent possible personal injury.
	Electrical Hazard icons alert you to a possible electrical shock.
	Hot Surface icons warn you not to touch printer parts that are hot.
	Cautions specify procedures you must follow or avoid to prevent possible damage to the printer or other objects.
<b>Note</b>	Notes tell you useful tips when servicing the printer.
<b>Memo</b>	Memo tells you bits of knowledge to help understand the printer.

## ■ Safety Precautions

Listed below are the various kinds of “WARNING” messages included in this manual.

<p> <b>WARNING</b></p>
<p></p> <p>There are high voltage electrodes inside the printer. Before you clean the inside of the printer or replace parts, make sure that you have turned off the power switch and unplugged the printer from the AC power outlet.</p> 
<p></p> <p>DO NOT handle the plug with wet hands. Doing this might cause an electrical shock.</p> 
<p></p> <p>The fuser unit becomes extremely hot during operation. Wait until it has cooled down sufficiently before replacing consumable items. DO NOT remove or damage the caution label located on or around the fuser.</p> 

 **WARNING**

DO NOT use flammable substances such as alcohol, benzene, thinner or any type of spray to clean the inside or outside of the printer. Doing this may cause a fire or electrical shock.



If the printer becomes hot, blows smoke, or generates obscure odor, immediately turn off the power switch and unplug the printer from the AC power outlet.

If metal objects, water or other liquids get inside the printer, immediately turn off the power switch and unplug the printer from the AC power outlet.

**Caution**

Lightning and power surges can damage this product! We recommend that you use a quality surge protection device on the AC power line, or unplug the printer during a lightning storm.

# CHAPTER 1 SPECIFICATIONS

## 1. SPECIFICATIONS LIST

### 1.1 General

Model		HL-2130	HL-2220	HL-2230	HL-2240
Print method		Electrophotographic / Laser			
Resolution		600 x 600 dpi, HQ1200 (2400 x 600 dpi) quality			
Print speed		Up to 20/21 ppm (A4/Letter size)		Up to 24/24 ppm (A4/Letter size)	
		* When loading A4 or Letter-size paper from the paper tray.			
Warm-up time	From Sleep mode	Less than 7 seconds at 23°C (73.4 F)			
	From Power OFF: → ON	Less than 25 seconds at 23°C (73.4 F)			
First print time	From Ready mode	Less than 10 seconds		Less than 8.5 seconds	
	From Sleep mode	Less than 19 seconds		Less than 16.5 seconds	
CPU		ARM9 200MHz			
Memory		8 MB			
Interface		Hi-Speed USB 2.0			
Power Consumption	Peak	1056W			
	Printing	Average: Approx. 421 W		Average: Approx. 495 W	
	Ready	Average: Approx. 62 W		Average: Approx. 65 W	
	Sleep, Wireless LAN: ON	N/A			
	Deep Sleep	Average: Approx. 0.8 W		Average: Approx. 0.9 W	
Noise level	Sound pressure	Printing	LWAd = 53 dB(A)		
		Ready	LWAd = 31 dB(A)		
	Sound power	Printing	For U.S.A./China LWAd = 6.60 B(A) Except for U.S.A./China LWAd = 6.40 B(A)		LWAd = 6.70 B(A)
		Ready	For U.S.A./China LWAd = 4.60 B(A) Except for U.S.A./China LWAd = 4.54 B(A)		LWAd = 4.60 B(A)
Environment	Temperature	Operating: 10 to 32.5°C Storage: 0 to 40°C			
	Humidity	Operating: 20 to 80 % Storage: 10 to 90 %			
Dimensions (WxDxH)	Carton	475 x 454 x 331 mm (18.7 x 17.9 x 13.0 in.)			
	Printer	368 x 360 x 183 mm (14.5 x 14.2 x 7.2 in.)			
Weights	without Carton, with toner/drum	6.7kg / 14.8lb			

Specifications are subject to change without prior notice.

Model		HL-2240D	HL-2250DN	HL-2270DW	
Print method		Electrophotographic / Laser			
Resolution		600 x 600 dpi, HQ1200 (2400 x 600 dpi) quality			
Print speed		Up to 24/24 ppm (A4/Letter size)	Up to 26/27 ppm (A4/Letter size)		
		* When loading A4 or Letter-size paper from the paper tray.			
Warm-up time	From Sleep mode	Less than 7 seconds at 23°C (73.4 F)			
	From Power OFF: → ON	Less than 25 seconds at 23°C (73.4 F)	Less than 26 seconds at 23°C (73.4 F)		
First print time	From Ready mode	Less than 8.5 seconds			
	From Sleep mode	Less than 16.5 seconds			
CPU		ARM9 200MHz			
Memory		8 MB	32 MB		
Interface		Hi-Speed USB 2.0	Hi-Speed USB 2.0, Ethernet 10/100 BASE-TX	Hi-Speed USB 2.0, Ethernet 10/100 BASE-TX, IEEE802.11b/g (Infrastructure Mode/Adhoc Mode)	
Power Consumption	Peak	1056W			
	Printing	Average: Approx. 495 W			
	Ready	Average: Approx. 65 W			
	Sleep, Wireless LAN: ON	N/A		Average: Approx. 2.8 W	
	Deep Sleep	Average: Approx. 0.9 W			
Noise level	Sound pressure	Printing	LWAd = 53 dB(A)		
		Ready	LWAd = 31 dB(A)		
	Sound power	Printing	For U.S.A./China LWAd = 6.70 B(A) Except for U.S.A./China LWAd = 6.65 B(A)	For U.S.A./China LWAd = 6.70 B(A) Except for U.S.A./China LWAd = 6.67 B(A)	
		Ready	For U.S.A./China LWAd = 4.60 B(A) Except for U.S.A./China LWAd = 4.50 B(A)	For U.S.A./China LWAd = 4.60 B(A) Except for U.S.A./China LWAd = 5.02 B(A)	
Environment	Temperature	Operating: 10 to 32.5°C Storage: 0 to 40°C			
	Humidity	Operating: 20 to 80 % Storage: 10 to 90 %			
Dimensions (WxDxH)	Carton	475 x 454 x 331 mm (18.7 x 17.9 x 13.0 in.)			
	Printer	368 x 360 x 183 mm (14.5 x 14.2 x 7.2 in.)			
Weights	without Carton, with toner/drum	7.0kg / 15.4lb			

Specifications are subject to change without prior notice.

**<Computer requirements>**

Computer Platform & Operating System Version		Processor Minimum Speed	Minimum RAM	Recommended RAM	Hard Disk Space to install	Supported PC Interface *2
Windows® Operating System *1	Windows® 2000 Professional	Intel® Pentium® II or equivalent	64 MB	256 MB	50 MB	USB, 10BASE-T / 100BASE-TX (Ethernet), Wireless 802.11b/g
	Windows® XP Home Edition		128 MB			
	Windows® XP Professional					
	Windows® XP Professional x64 Edition	64-bit (Intel® 64 or AMD 64) supported CPU	256 MB	512 MB		
	Windows Vista®	Intel® Pentium® 4 or equivalent 64-bit (Intel® 64 or AMD 64) supported CPU	512 MB	1 GB		
	Windows® 7	Intel® Pentium® 4 or equivalent 64-bit (Intel® 64 or AMD 64) supported CPU	1 GB (32-bit) 2 GB (64-bit)	1 GB (32-bit) 2 GB (64-bit)		
	Windows Server® 2003	Intel® Pentium® III or equivalent	256 MB	512 MB		
	Windows Server® 2003 x64 Edition	64-bit (Intel® 64 or AMD 64) supported CPU				
	Windows Server® 2008	Intel® Pentium® 4 or equivalent 64-bit (Intel® 64 or AMD 64) supported CPU	512 MB	2 GB		
Windows Server® 2008 R2	64-bit (Intel® 64 or AMD 64) supported CPU					
Macintosh Operating System	Mac OS X 10.4.11 and 10.5.x	Power PC® G4/G5 Intel® Core™ Processor	512 MB	1 GB	80 MB	
	Mac OS X 10.6.x	Intel® Core™ Processor	1 GB	2 GB		

\*1 Microsoft® Internet Explorer® 6.0 or greater.

\*2 Third party USB ports are not supported.

Specifications are subject to change without prior notice.

## 1.2 Network Connectivity

Model		HL-2130	HL-2220	HL-2230	HL-2240
Wired network	Network node type	N/A			
	Network type	N/A			
Wireless network	Network node type	N/A			
	Network type	N/A			
	Network security	N/A			

Model		HL-2240D	HL-2250DN	HL-2270DW
Wired network	Network node type	N/A	NC-8200h	
	Network type	N/A	10/100BASE-TX	
Wireless network	Network node type	N/A		NC-7800w
	Network type	N/A		IEEE 802.11b/g (Infrastructure Mode / Adhoc Mode)
	Network security	N/A		WEP 64/128 bit, WPA-PSK (TKIP/AES), WPA2-PSK (AES), APOP, POP before SMTP, SMTP-AUTH

Specifications are subject to change without prior notice.

### 1.3 Service Information

Model		HL-2130	HL-2220	HL-2230	HL-2240
Printer life		50,000 pages (A4 / Letter) or 5 years under normal use at normal temperature and humidity.			
MTBF		4,000 hours			
MTTR		0.5 hours			
Maximum monthly volume		Up to 8,000 pages		Up to 10,000 pages	
Parts life	Fuser Unit	50,000 pages or 5 years			
	Laser Unit				
	PF kit				

Model		HL-2240D	HL-2250DN	HL-2270DW
Printer life		50,000 pages (A4 / Letter) or 5 years under normal use at normal temperature and humidity.		
MTBF		4,000 hours		
MTTR		0.5 hours		
Maximum monthly volume		Up to 10,000 pages		
Parts life	Fuser Unit	50,000 pages or 5 years		
	Laser Unit			
	PF kit			

Specifications are subject to change without prior notice.

## 1.4 Supplies

Model		HL-2130	HL-2220	HL-2230	HL-2240
Toner cartridge	Starter Toner	Approx. 700 pages			
	Standard Toner	Except for Asia Approx. 1,000 pages For Asia: 700 pages	Approx. 1,200 pages		
	High Capacity Toner	N/A	Approx. 2,600 pages		
Approx. cartridge yield is declared in accordance with ISO/IEC 19752 Shelf life: 2 years without opening (6 months after opening)					
Drum unit		Life expectancy: Approx. 12,000 pages/drum unit The life expectancy varies according to the use condition. Shelf life: 2 years			

Model		HL-2240D	HL-2250DN	HL-2270DW
Toner cartridge	Starter Toner	Except for Asia/Russia Approx. 700 pages For Asia/Russia: Approx. 1,200 pages		Except for Europe: Approx. 700 pages For Europe: Approx 1,200 pages
	Standard Toner	Approx. 1,200 pages		
	High Capacity Toner	Approx. 2,600 pages		
Approx. cartridge yield is declared in accordance with ISO/IEC 19752 Shelf life: 2 years without opening (6 months after opening)				
Drum unit		Life expectancy: Approx. 12,000 pages/drum unit The life expectancy varies according to the use condition. Shelf life: 2 years		
<p>The shelf life of toner cartridge and drum unit is guaranteed under the normal condition as below;</p> <p>(Temperature) Normal condition: 0 to 40 °C</p> <p>* Storage condition at the temperature of 40 to 50 °C: Up to 5 days</p> <p>* Storage condition at the temperature of -20 to 0 °C: Up to 5 days</p> <p>(Humidity) Normal condition: 35 to 85 %</p> <p>* Storage condition at the humidity of 85 to 95 %: Up to 5 days</p> <p>* Storage condition at the humidity of 10 to 35%: Up to 5 days</p>				

Specifications are subject to change without prior notice.

## 1.5 Paper

### 1.5.1 Paper handling

Model		HL-2130	HL-2220	HL-2230	HL-2240
Paper Input	Manual feed slot	1 sheet			
	Paper tray	250 sheets			
Paper Output	Face-down	100 Sheets (80g/m <sup>2</sup> )			
	Face-up	1 sheet (straight paper path)			

Model		HL-2240D	HL-2250DN	HL-2270DW
Paper Input	Manual feed slot	1 sheet		
	Paper tray	250 sheets		
Paper Output	Face-down	100 Sheets (80g/m <sup>2</sup> )		
	Face-up	1 sheet (straight paper path)		

### 1.5.2 Media specifications

Model		HL-2130	HL-2220	HL-2230	HL-2240
Media type	Paper tray	Plain Paper, Thin Paper, Recycled Paper			
	Manual Feed Slot	Plain Paper, Thin Paper, Thick Paper, Recycled Paper, Bond Paper, Labels, Envelopes			
	Duplex printing	N/A			
Media weight	Paper tray	60 - 105 g/m <sup>2</sup> (16 - 28 lb)			
	Manual Feed Slot	60 - 163 g/m <sup>2</sup> (16 - 43 lb)			
	Duplex printing	N/A			
Media size	Paper tray	A4, Letter, B5 (ISO/JIS), A5, A5 (Long Edge), B6 (ISO), A6, Executive, Legal, Folio 16K (only for China)			
	Manual Feed Slot	Width 76.2 to 216 mm, Length 116 to 406.4 mm (Width 3.0 to 8.5 in., Length 4.6 to 16 in.)			
	Duplex printing	N/A			

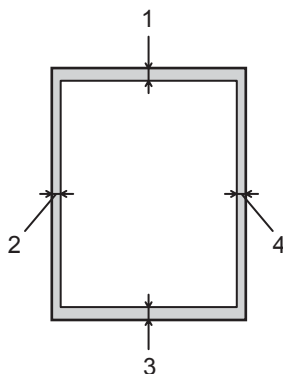
Model		HL-2240D	HL-2250DN	HL-2270DW
Media type	Paper tray	Plain Paper, Thin Paper, Recycled Paper		
	Manual Feed Slot	Plain Paper, Thin Paper, Thick Paper, Recycled Paper, Bond Paper, Labels, Envelopes		
	Duplex printing	Plain Paper, Thin Paper, Recycled Paper		
Media weight	Paper tray	60 - 105 g/m <sup>2</sup> (16 - 28 lb)		
	Manual Feed Slot	60 - 163 g/m <sup>2</sup> (16 - 43 lb)		
	Duplex printing	60 - 105 g/m <sup>2</sup> (16 - 28 lb)		
Media size	Paper tray	A4, Letter, B5 (ISO/JIS), A5, A5 (Long Edge), B6 (ISO), A6, Executive, Legal, Folio 16K (only for China)		
	Manual Feed Slot	Width 76.2 to 216 mm, Length 116 to 406.4 mm (Width 3.0 to 8.5 in., Length 4.6 to 16 in.)		
	Duplex printing	For U.S.A. : Letter, Legal, Folio Except for U.S.A. : A4		

Specifications are subject to change without prior notice.

## 1.6 Printable Area

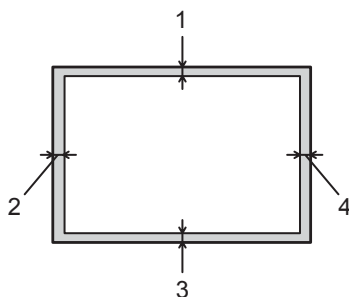
The area of the paper that cannot be printed on is shown in the table below:

Portrait



	<b>A4</b>	<b>Letter</b>	<b>Legal</b>	<b>B5 (ISO)</b>	<b>Executive</b>	<b>A5</b>	<b>A6</b>	<b>B6 (ISO)</b>
1	4.23 mm (0.16 in.)	4.23 mm (0.16 in.)	4.23 mm (0.16 in.)	4.23 mm (0.16 in.)	4.23 mm (0.16 in.)	4.23 mm (0.16 in.)	4.23 mm (0.16 in.)	4.23 mm (0.16 in.)
2	6.01 mm (0.24 in.)	6.35 mm (0.25 in.)	6.35 mm (0.25 in.)	6.01 mm (0.24 in.)	6.35 mm (0.25 in.)	6.01 mm (0.24 in.)	6.01 mm (0.24 in.)	6.01 mm (0.24 in.)
3	4.23 mm (0.16 in.)	4.23 mm (0.16 in.)	4.23 mm (0.16 in.)	4.23 mm (0.16 in.)	4.23 mm (0.16 in.)	4.23 mm (0.16 in.)	4.23 mm (0.16 in.)	4.23 mm (0.16 in.)
4	6.01 mm (0.24 in.)	6.35 mm (0.25 in.)	6.35 mm (0.25 in.)	6.01 mm (0.24 in.)	6.35 mm (0.25 in.)	6.01 mm (0.24 in.)	6.01 mm (0.24 in.)	6.01 mm (0.24 in.)

Landscape



	<b>A4</b>	<b>Letter</b>	<b>Legal</b>	<b>B5 (ISO)</b>	<b>Executive</b>	<b>A5</b>	<b>A6</b>	<b>B6 (ISO)</b>
1	4.23 mm (0.16 in.)	4.23 mm (0.16 in.)	4.23 mm (0.16 in.)	4.23 mm (0.16 in.)	4.23 mm (0.16 in.)	4.23 mm (0.16 in.)	4.23 mm (0.16 in.)	4.23 mm (0.16 in.)
2	5.0 mm (0.19 in.)	5.08 mm (0.2 in.)	5.08 mm (0.2 in.)	5.0 mm (0.19 in.)	5.08 mm (0.2 in.)	5.0 mm (0.19 in.)	5.0 mm (0.19 in.)	5.0 mm (0.19 in.)
3	4.23 mm (0.16 in.)	4.23 mm (0.16 in.)	4.23 mm (0.16 in.)	4.23 mm (0.16 in.)	4.23 mm (0.16 in.)	4.23 mm (0.16 in.)	4.23 mm (0.16 in.)	4.23 mm (0.16 in.)
4	5.0 mm (0.19 in.)	5.08 mm (0.2 in.)	5.08 mm (0.2 in.)	5.0 mm (0.19 in.)	5.08 mm (0.2 in.)	5.0 mm (0.19 in.)	5.0 mm (0.19 in.)	5.0 mm (0.19 in.)

Specifications are subject to change without prior notice.

---

## CHAPTER 2 TROUBLESHOOTING

---

### 1. INTRODUCTION


---

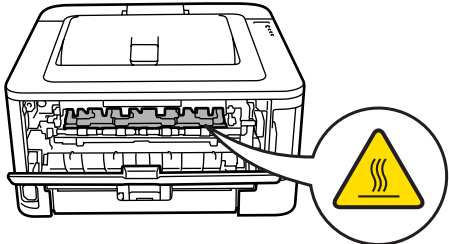
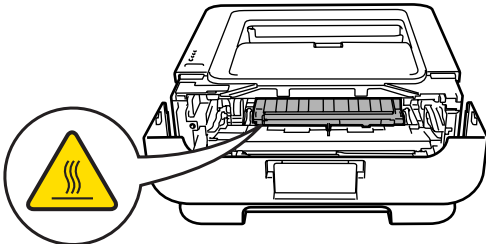
Troubleshooting is the countermeasure procedures that the service personnel should follow if an error or malfunction occurs with the printer. It is impossible to anticipate all of the possible troubles which may occur in future and determine the troubleshooting procedures, so this chapter covers some sample troubles. However, those samples will help the service personnel pinpoint and repair other defective elements.


#### 1.1 Precautions

Be sure to observe and follow all the precautions to prevent any secondary problems from happening during troubleshooting.




- (1) Always turn off the power and unplug the power cable before removing any covers or PCBs, adjusting the printer and so on. If you need to take voltage measurements with the power switched on, take the greatest of care not to receive an electric shock.
- (2) When connecting or disconnecting cable connectors, make sure that you hold the connector body and not the cables.
- (3) Static electricity charged in your body may damage electronic parts. Before handling the PCBs, touch a metal portion of the printer to discharge static electricity charged in your body. When transporting PCBs, be sure to wrap them in conductive sheets. When replacing the PCBs, put on a grounding wrist band and perform the job on a conductive mat. Also take care not to touch the conductor sections on the flat cables.
- (4) Follow the warning by all means.

 The fuser unit becomes extremely hot during operation. Wait until it has cooled down sufficiently before replacing consumable items. **DO NOT** remove or damage the caution label located on or around the fuser.



 **WARNING**

**DO NOT** use flammable substances such as alcohol, benzine, thinner or any type of spray to clean the inside or outside of the printer. Doing this may cause a fire or electrical shock.



- (5) Verify again that the repaired portion works properly.

## 1.2 Initial Check

Check the following items before attempting to repair the printer.

### ■ Operating Environment

- (1) Put your printer on a flat, stable surface such as a desk that is free of vibration and shocks.
- (2) Use the printer in a well-ventilated room; use the printer within the following ranges of temperature and humidity: temperature between 10°C and 32.5°C (50°F to 90.5°F), and the relative humidity is maintained between 20% and 80%.
- (3) The printer is not exposed to direct sunlight, excessive heat, moisture, or dust.
- (4) Keep the printer horizontal when you carry it.

### ■ Power Supply

- (1) The AC input power supply described on the rating plate of the printer should be within  $\pm 10\%$  of the rated voltage.
- (2) The AC input power supply is within the regulated value.
- (3) The cables and harnesses are connected correctly.
- (4) The fuses are not blown.

### ■ Paper

- (1) A recommended type of paper is being used.  
(Refer to "[1.5.2 Media specifications](#)" in Chapter 1.)
- (2) The paper is not damp.
- (3) The paper is not short-grained paper or acid paper.

### ■ Consumable Parts

- (1) The drum unit (including the toner cartridge) is installed correctly.

## ■ Others

### (1) Condensation

When the printer is moved from a cold place into a warm room, condensation may occur inside the printer, causing various problems as listed below.

- Condensation on the optical surfaces such as the lenses, the reflection mirror and the protection glass may cause the print image to be light.
- If the exposure drum is cold, the electrical resistance of the photosensitive layer is increased, making it impossible to obtain the correct contrast when printing.
- Condensation on the charge unit may cause corona charge leakage.
- Condensation on the plate and separation pad may cause paper feed failures.

If condensation has occurred, leave the printer for at least two hours to allow it to reach room temperature.

If the drum unit is unpacked soon after it is moved from a cold place to a warm room, condensation may occur inside the unit which may cause incorrect images. Instruct the user to allow the unit to come to room temperature before unpacking it. This will take one or two hours.

### (2) Low temperature

The motor may not drive normally under the low temperature environment. This is due to there being too much load to drive each unit. In this case, increase the room temperature.

## ■ Cleaning

Use a soft dry lint-free cloth.

### **CAUTION:**

DO NOT use flammable substances, any type of spray or any organic solvent/liquids contains alcohol or ammonia to clean the inside or outside of the printer. Doing this may cause a fire or electrical shock.



## 2. OVERVIEW

### 2.1 Cross-section Drawing

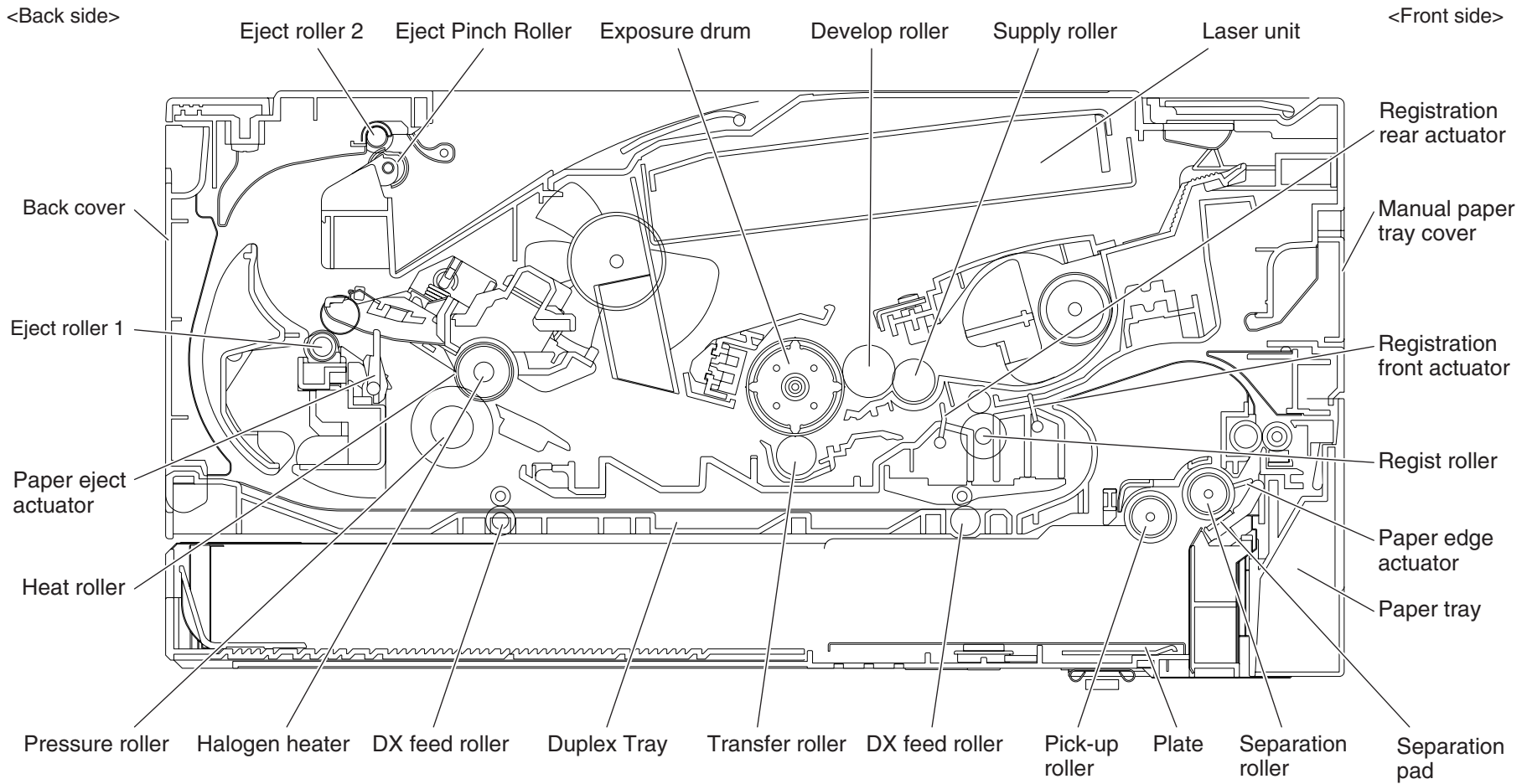


Fig. 2-1

## 2.2 Paper Feeding

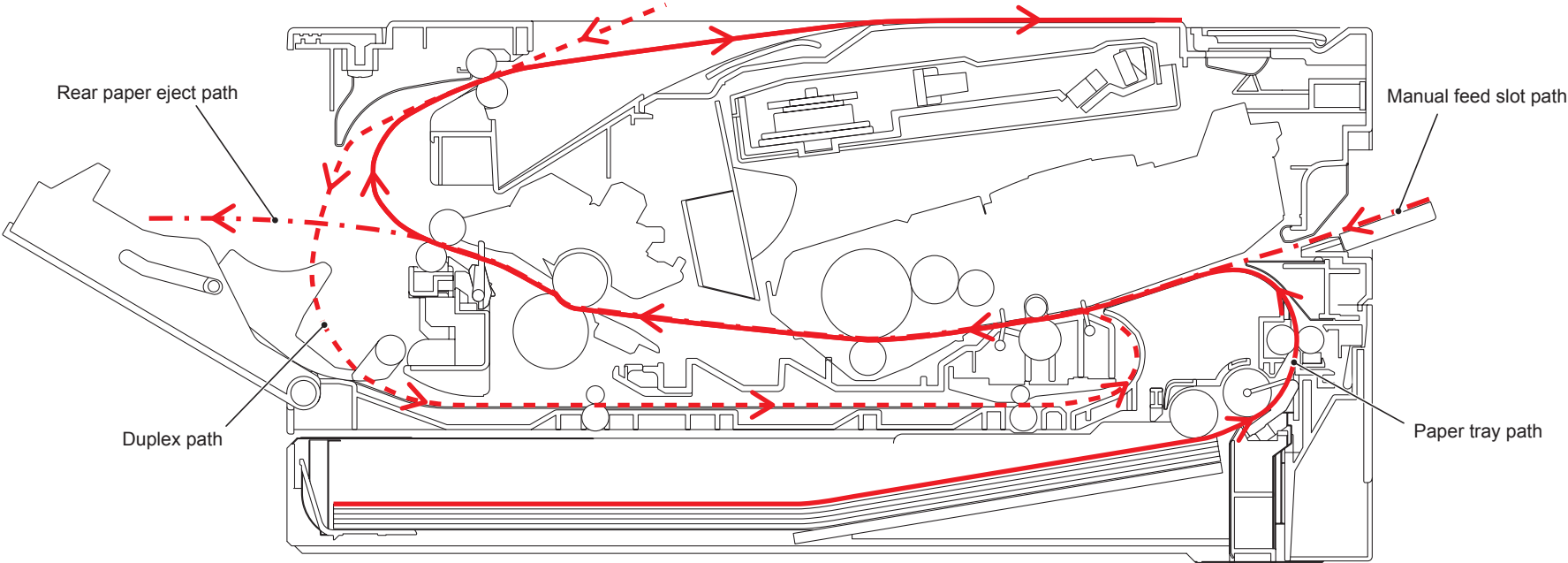


Fig. 2-2

## 2.3 Operation of each part

Part name	Operation
Pick-up roller	Feed the paper from the paper tray.
Separation roller and Separation pad	Separate into single sheet from the paper tray.
Paper edge actuator (HL-2250DN/2270DW only)	Detect the rear edge of paper, and identify the paper size.
Registration front actuator	Detect the front edge of paper, and control the drive of registration roller. When feeding from the manual feed slot, detect the passage of paper. Detect the paper jam of front part.
Registration roller	When the front edge of the paper hit the stopped registration roller and the inclination of the paper is corrected.
Registration rear actuator	Detect the passage of paper and adjust the starting position for writing on a sheet of paper. When the duplex printing, detect the rear edge of paper and adjust the timing of eject roller 2 switching.
Transfer roller	By applying a minus charge to the transfer roller, the toner adhered to the exposure drum is transferred to paper, and feed the paper to the fuser unit.
Heat roller and Pressure roller	The toner transferred on paper being fused by heat and pressure, and feed the paper to the eject roller 1.
Paper eject actuator	Detect whether or not paper is ejected from the fuser unit.
Eject roller 1	Feed the paper ejected from the fuser unit to the eject roller 2.
Eject roller 2	Eject the paper to the face-down output tray. When the duplex printing, after the paper is fed from the eject roller 2 with the front of sheet printed, the eject roller 2 rotates conversely and feed the paper to the duplex tray.
DX feed roller (HL-2240D/2250DN/2270DW only)	Feed the paper passed in the duplex tray to the registration roller.

## 2.4 Block Diagram

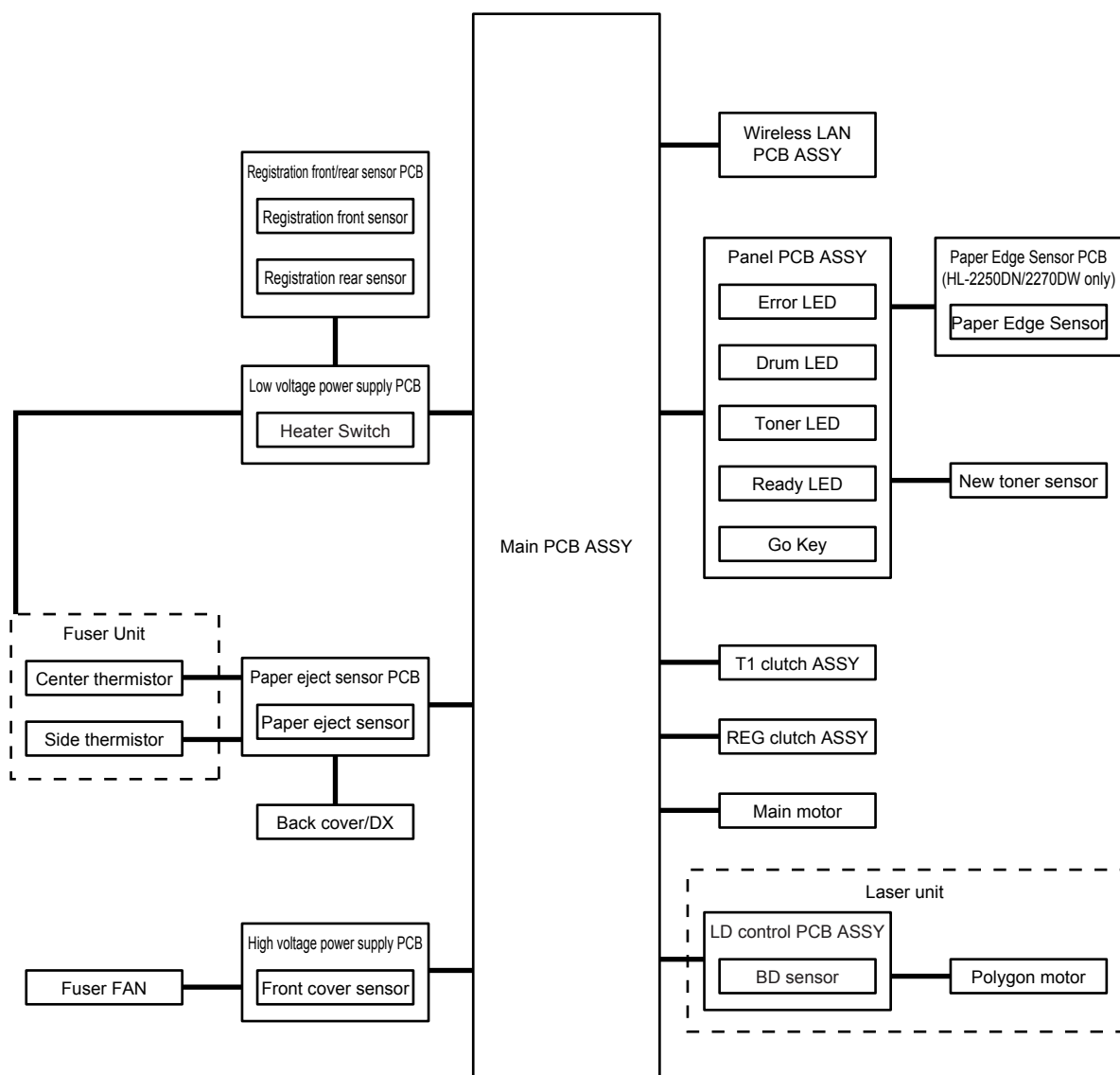


Fig. 2-3

## 2.5 Components

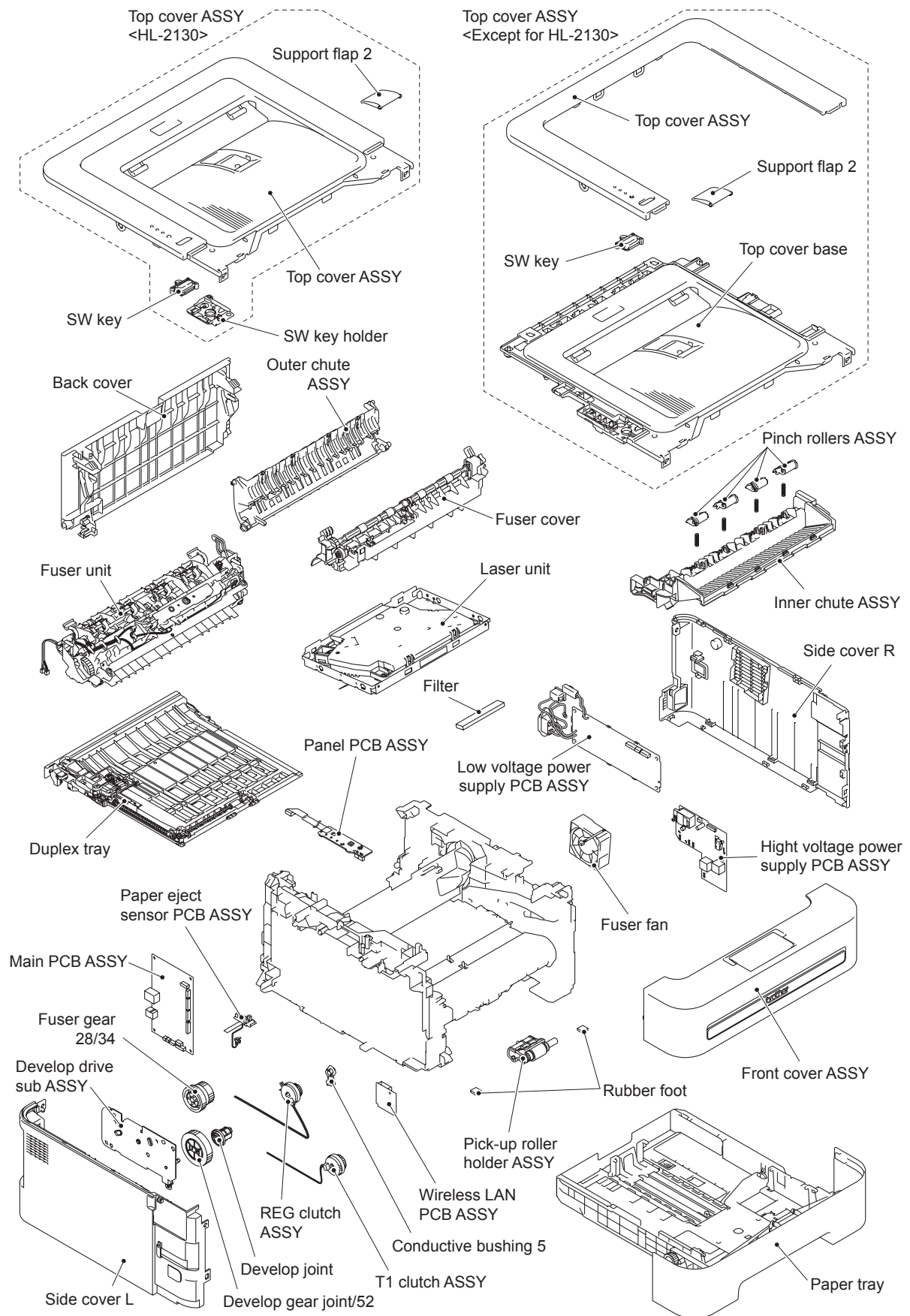


Fig. 2-4

### 3. LED ERROR INDICATION AND FAILURES

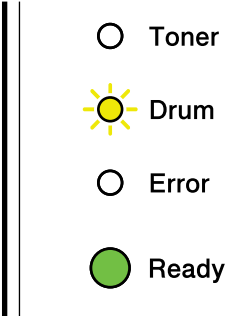
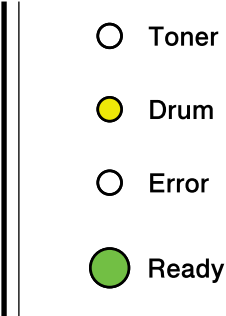
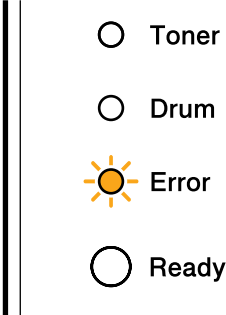
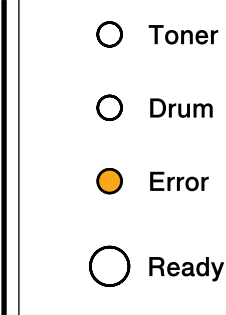
#### 3.1 LED indication at Operator Calls

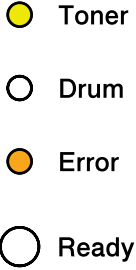
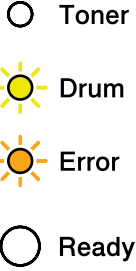
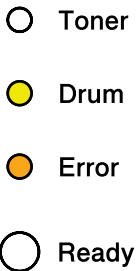
Distinguish the contents of error by LED indication in the control panel. See the reference page and take the corrective action described for each indication to correct it. When the red Error LED is ON or blinking to indicate it, the printer automatically recovers from most errors. But some of errors are necessary to reset the printer by holding down the [Go] button.

LED indication of the following table is that

- LED is OFF, ● LED is ON and ☀ LED is blinking.

LED	Type of error	Refer to:
<p>Error LED and Ready LED : ( Turn on alternately ) for 0.5 seconds</p>	<b>JOB CANCELING</b>	—
<p>Toner LED : (On for 2 seconds) (Off for 3 seconds)</p>	<b>TONER LOW</b>	4.5.3
	<b>REPLACE TONER</b>	4.5.4
	<b>CARTRIDGE ERROR</b>	4.5.2
	<b>NO TONER</b>	4.5.6

LED	Type of error	Refer to:
 <p>Drum : (On for 2 seconds) LED : (Off for 3 seconds)</p>	<b>DRUM END SOON</b>	4.5.7
	<b>REPLACE DRUM</b>	4.5.9
 <p>Error : (On for 0.5 seconds) LED : (Off for 0.5 seconds)</p>	<b>FRONT COVER OPEN</b>	4.9.4
	<b>FUSER COVER OPEN</b>	4.9.5
	<b>JAM TRAY1/JAM INSIDE</b>	4.1.5
	<b>JAM REAR</b>	4.1.5
	<b>JAM DUPLEX</b>	4.1.5
	<b>MEMORY FULL</b>	4.8.2
	<b>PRINT OVERRUN</b>	4.8.3
	<b>SIZE ERROR DX</b>	4.1.13
	<b>NO PAPER T1</b>	4.1.2
	<b>MANUAL FEED</b>	4.1.3

LED	Type of error	Refer to:
	<b>TONER ENDED</b>	<p style="text-align: center;">4.5.5</p>
 <p data-bbox="295 952 526 1052">Drum LED and Error LED : ( On for 0.5 seconds ) ( Off for 0.5 seconds )</p>	<b>DRUM ERROR</b>	<p style="text-align: center;">4.5.8</p>
	<b>DRUM STOP</b>	<p style="text-align: center;">4.5.9</p>

### 3.2 LED indication at Service Calls

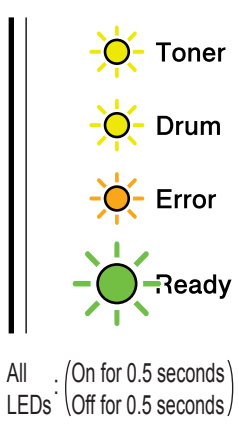
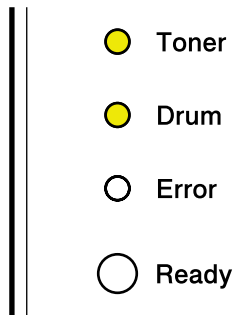
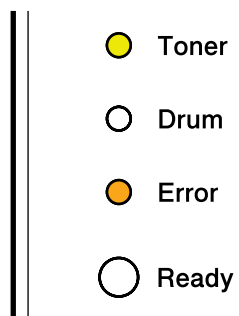
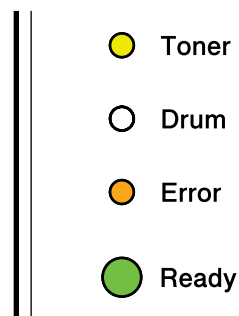
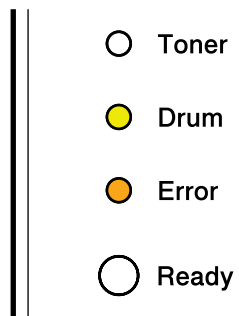
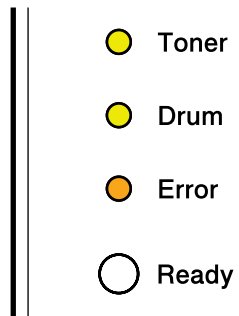
If service calls occur, all four LEDs blink on and off to notice it. And then when press the [Go] button, distinguish a fault from the specific combination of ON/OFF and status color of the LEDs. When entering this state, instruct the end user to turn off the power switch once, and wait a few seconds. Then, turn on the power switch again. However, if the error is not cleared and the service call is appeared, see the reference page to take the corrective action.

LED	Pressing one time of the [Go] button	Pressing two times of the [Go] button	Type of error	Refer to:
<p>All LEDs: (On for 0.5 seconds) (Off for 0.5 seconds)</p>	<p>(Fuser Unit Failure)</p>	<ul style="list-style-type: none"> <li><input type="radio"/> Toner</li> <li><input type="radio"/> Drum</li> <li><input type="radio"/> Error</li> <li><input checked="" type="radio"/> Ready</li> </ul>	Fuser unit failure	4.6.1
		<ul style="list-style-type: none"> <li><input checked="" type="radio"/> Toner</li> <li><input type="radio"/> Drum</li> <li><input type="radio"/> Error</li> <li><input checked="" type="radio"/> Ready</li> </ul>		
		<ul style="list-style-type: none"> <li><input type="radio"/> Toner</li> <li><input checked="" type="radio"/> Drum</li> <li><input type="radio"/> Error</li> <li><input checked="" type="radio"/> Ready</li> </ul>		
		<ul style="list-style-type: none"> <li><input type="radio"/> Toner</li> <li><input type="radio"/> Drum</li> <li><input checked="" type="radio"/> Error</li> <li><input checked="" type="radio"/> Ready</li> </ul>		

LED	Pressing one time of the [Go] button	Pressing two times of the [Go] button	Type of error	Refer to:
<p>All LEDs : (On for 0.5 seconds)           : (Off for 0.5 seconds)</p>	<p>( Fuser Unit Failure )</p>	  	<p>Fuser unit failure</p>	<p>4.6.1</p>

LED	Pressing one time of the [Go] button	Pressing two times of the [Go] button	Type of error	Refer to:	
<p>All LEDs : (On for 0.5 seconds) LEDs : (Off for 0.5 seconds)</p>	<ul style="list-style-type: none"> <li><input type="radio"/> Toner</li> <li><input checked="" type="radio"/> Drum</li> <li><input type="radio"/> Error</li> <li><input type="radio"/> Ready</li> </ul> <p>(Laser Unit Failure)</p>	<ul style="list-style-type: none"> <li><input type="radio"/> Toner</li> <li><input checked="" type="radio"/> Drum</li> <li><input type="radio"/> Error</li> <li><input checked="" type="radio"/> Ready</li> </ul>	Laser unit failure	4.7.1	
		<ul style="list-style-type: none"> <li><input type="radio"/> Toner</li> <li><input checked="" type="radio"/> Drum</li> <li><input checked="" type="radio"/> Error</li> <li><input checked="" type="radio"/> Ready</li> </ul>	Polygon motor failure		4.7.1
	<ul style="list-style-type: none"> <li><input type="radio"/> Toner</li> <li><input type="radio"/> Drum</li> <li><input checked="" type="radio"/> Error</li> <li><input type="radio"/> Ready</li> </ul> <p>(Main PCB Failure)</p>	<ul style="list-style-type: none"> <li><input checked="" type="radio"/> Toner</li> <li><input type="radio"/> Drum</li> <li><input type="radio"/> Error</li> <li><input checked="" type="radio"/> Ready</li> </ul>	<ul style="list-style-type: none"> <li><input type="radio"/> Toner</li> <li><input type="radio"/> Drum</li> <li><input type="radio"/> Error</li> <li><input checked="" type="radio"/> Ready</li> </ul>	Main PCB failure	4.8.1
		<ul style="list-style-type: none"> <li><input type="radio"/> Toner</li> <li><input type="radio"/> Drum</li> <li><input checked="" type="radio"/> Error</li> <li><input checked="" type="radio"/> Ready</li> </ul>			

LED	Pressing one time of the [Go] button	Pressing two times of the [Go] button	Type of error	Refer to:
<p>All LEDs (On for 0.5 seconds) LEDs (Off for 0.5 seconds)</p>	<p>(Main PCB Failure)</p>		Main PCB failure	4.8.1

LED	Pressing one time of the [Go] button	Pressing two times of the [Go] button	Type of error	Refer to:
 <p>All LEDs : (On for 0.5 seconds) (Off for 0.5 seconds)</p>	 (High Voltage Failure)	—	High voltage power supply PCB ASSY failure	4.8.4
			Main motor failure	4.9.3
		—	Fuser fan failure or Harness connection failure of T1 clutch ASSY	4.9.2
		—	Irregular power supply detection error	4.8.5

### 3.3 Error messages in the Status Monitor

The Status Monitor will report problems with the printer. Take the proper action by seeing to the reference page.

Error message	Refer to:
CANNOT DETECT TONER	<a href="#">4.5.2</a>
DRUM END SOON	<a href="#">4.5.7</a>
DRUM ERROR	<a href="#">4.5.8</a>
DRUM STOP	<a href="#">4.5.9</a>
DUPLEX DISABLED*	<a href="#">4.1.11</a>
FRONT COVER OPEN	<a href="#">4.9.4</a>
FUSER COVER OPEN	<a href="#">4.9.5</a>
FUSER ERROR	<a href="#">4.6.1</a>
JAM TRAY1 JAM INSIDE JAM REAR JAM DUPLEX*	<a href="#">4.1.5</a>
MANUAL FEED	<a href="#">4.1.3</a>
MEMORY FULL	<a href="#">4.8.2</a>
NO PAPER T1	<a href="#">4.1.2</a>
NO TONER	<a href="#">4.5.6</a>
PRINT OVERRUN	<a href="#">4.8.3</a>
REPLACE DRUM	<a href="#">4.5.9</a>
REPLACE TONER	<a href="#">4.5.4</a>
Service call error	—
SIZE ERROR DX*	<a href="#">4.1.13</a>
TONER ENDED	<a href="#">4.5.5</a>
TONER LOW	<a href="#">4.5.3</a>

\* This message is for HL-2240D/2250DN/2270DW only.

### 3.4 Error indication at Service Calls

If LED indication does not operate when service calls occur, distinguish the type of error by operating the Printer Settings printing or Maintenance printing. If you can not print, you can use a Maintenance tool to distinguish the type of error.

Error indication (Printout of Printer Settings)	Error indication (Printing for Maintenance)	Type of error	Refer to:
ERROR S01	ERROR S01	Main PCB failure	4.8.1
ERROR S02	ERROR S02		
ERROR S03	ERROR S03		
ERROR S04	ERROR S04		
ERROR S05	ERROR S05		
ERROR S06	ERROR S06		
ERROR S07	ERROR S07		
ERROR S08	ERROR S08		
ERROR S09	ERROR S09		
ERROR S10	ERROR S10		
ERROR S11	ERROR S11		
ERROR S12	ERROR S12		
ERROR S13	ERROR S13		
ERROR E49	FUSER MALF 2	Fuser unit failure	4.6.1
ERROR E50	FUSER MALF		
FUSER ERROR	FUSER ERROR		
ERROR E51	LASER BD MALF	Laser unit failure (Laser beam detection error)	4.7.1
ERROR E52	SCANNER MALF	Laser unit failure (Scanner motor failure)	4.7.1
ERROR E54	MOTOR MALF	Main motor failure	4.9.3
ERROR E55	HIGH VOL MALF	High voltage power supply PCB ASSY failure	4.8.4
ERROR E60	ERROR E60	Fuser fan failure or Harness connection failure of T1 clutch ASSY	4.9.2
ERROR H61	PROG ERROR	Main PCB failure	4.8.1
ERROR H63	ERROR H63		
ERROR H66	NV-W ERROR		
ERROR H67	NV-R ERROR		
ERROR H68	NV-B ERROR		
ERROR H75	ERROR H75	Irregular power supply detection error	4.8.5

## ■ How to start Maintenance tool

### Note :

- The printer driver of the relevant model must have been installed.

- (1) Connect the printer to PC with USB cable.
- (2) Double-click the “brmainte.exe” file (maintenance tool) to start.
- (3) Select the “Get Information” from Menu.
- (4) Select the applicable model name.
- (5) Check the port (USB) that the printer is connected through.
- (6) Click the [OK] button.
- (7) Appear the “Printer Information” window on the PC screen, and check the error indication.

### 3.5 Image Defect Examples

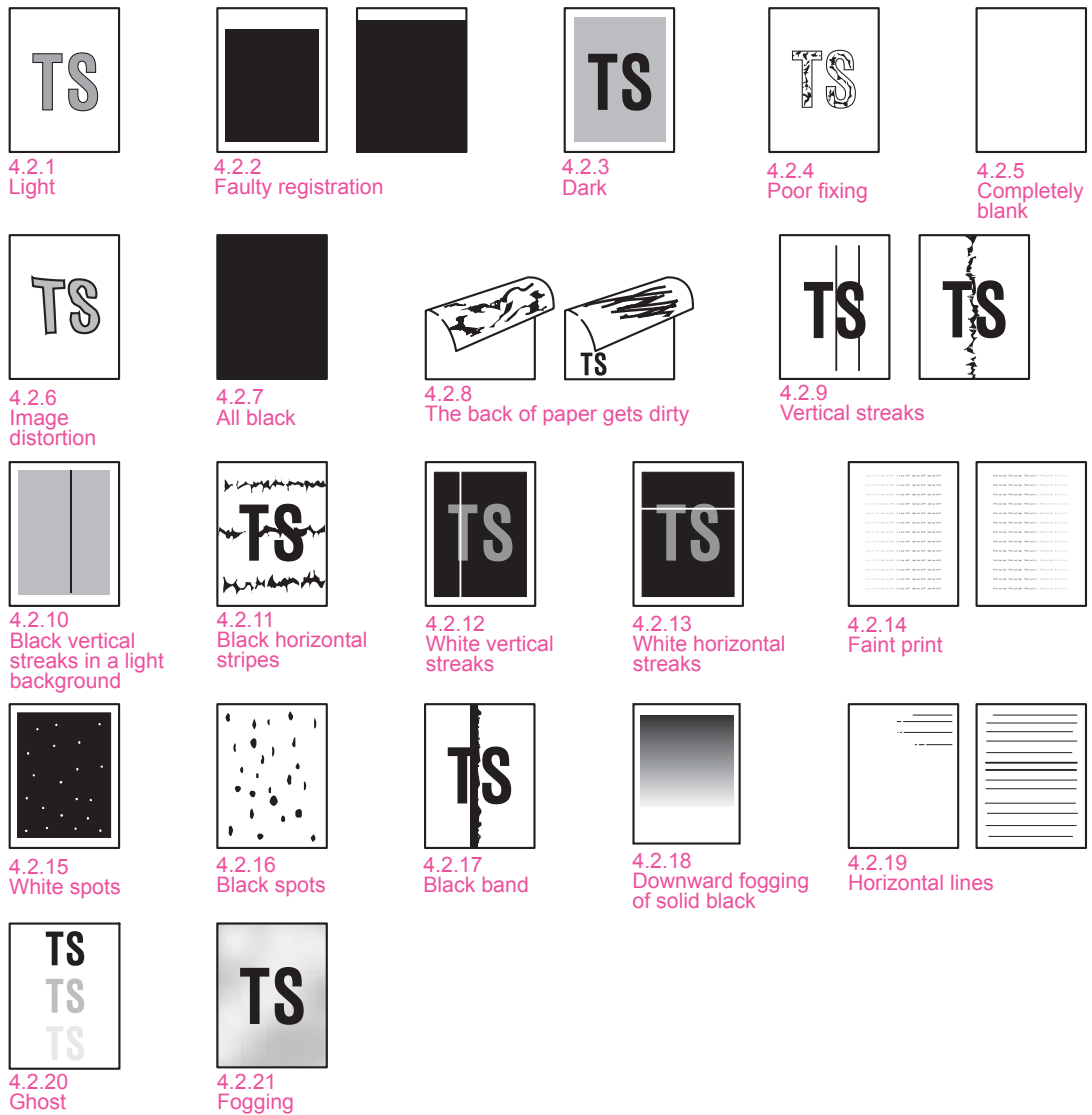


Fig. 2-5

## 4. ERROR SYMPTOM/ERROR CAUSE AND REMEDY

### 4.1 Paper Feeding Problems

Problems related to paper feeding are end user recoverable if following the User Check items. If the same problem occurs again, follow each procedure in the order of the number described in the Step column in the tables below.

#### 4.1.1 Pickup function of Paper tray does not work.

Step	Cause	Remedy
1	Link arm catching on some position	Re-assemble the link arm.
2	Pick-up roller holder ASSY catching on some position	Re-assemble the pick-up roller holder ASSY.
3	Harness connection failure of main motor	Reconnect the harness of the main motor.
4	Plate-up gear (gear Z19M10 or lift gear 46) failure	Replace the plate-up gear (gear Z19M10 or lift gear 46).
5	Main motor failure	Replace the main motor.
6	Low voltage power supply PCB ASSY failure	Replace the low voltage power supply PCB ASSY.
7	Main PCB failure	Replace the main PCB ASSY.

#### 4.1.2 No feeding

Not detect paper at feeding input

##### User Check

- Check if the paper tray is loaded correctly.
- Check if the paper is loaded into the paper tray correctly. Then press the [Go] button.
- Check that the paper smaller than the specified size is not loaded.
- Adjust the paper guide corresponding to the position of paper guide.
- Check if too much paper is loaded in the tray.
- Clean the surface of the separation pad or pick-up roller.

Step	Cause	Remedy
1	Lift arm and pick-up roller holder ASSY not assembled correctly	Re-assemble the lift arm and pick-up roller holder ASSY.
2	Harness connection failure of T1 clutch ASSY	Check the harness connections of the T1 clutch ASSY, and reconnect it.
3	Harness connection failure of paper edge sensor harness ASSY (HL-2250DN/2270DW only)	Check the harness connections of the paper edge sensor harness ASSY, and reconnect it.
4	Paper feeding roller failure	Replace the paper feeding kit.
5	Plate-up gear (gear Z19M10 or lift gear 46) failure	Replace the plate-up gear (gear Z19M10 or lift gear 46).
6	T1 clutch ASSY failure	Replace the T1 clutch ASSY.
7	Panel PCB failure	Replace the panel PCB ASSY.
8	Main PCB failure	Replace the main PCB ASSY.
9	Paper edge sensor failure (HL-2250DN/2270DW only)	Check the sensor performance following the procedure in " <a href="#">Operational Check of Sensors</a> " (Chapter 5). If any problem occurs, replace the PF frame ASSY.

### 4.1.3 No paper fed manual feed slot

Not detect paper at feeding from manual feed slot

#### User Check

- Load the paper into the manual feed slot.

Step	Cause	Remedy
1	Harness connection failure of registration front/rear sensor PCB ASSY	Check the harness connection of the registration front/rear sensor PCB ASSY, and reconnect it.
2	Low voltage power supply PCB ASSY failure	Replace the low voltage power supply PCB ASSY.
3	Main PCB failure	Replace the main PCB ASSY.
4	Registration front/rear sensor failure	Check the sensor performance following the procedure in " <a href="#">Operational Check of Sensors</a> " (Chapter 5). If any problem occurs, replace the regist frame ASSY.

### 4.1.4 Double feeding

#### User Check

- Check if the paper is loaded into the paper tray correctly.
- Check if the thickness of the paper is 60 to 105 g/m<sup>2</sup>.
- Clean the separation pad.
- Check that too much paper is not loaded in each tray.

Step	Cause	Remedy
1	Paper feeding roller failure	Replace the paper feeding kit.

## 4.1.5 Paper jam

- **Paper tray and front cover section**

Paper jam at paper tray and front cover section

### User Check

- Check if the paper is jammed in the paper tray and front cover section. If jammed, remove it.
- Adjust the paper guide corresponding to the paper size.
- Check if the thickness of the paper is 60 to 105 g/m<sup>2</sup>.
- Check if too much paper is loaded in the tray.

Step	Cause	Remedy
1	Paper edge actuator (HL-2250DN/2270DW only) or registration front actuator catching on some position	Correct catching of the paper edge actuator or registration front actuator.
2	Harness connection failure of registration front/rear sensor PCB ASSY	Check the harness connection of the registration front/rear sensor PCB ASSY, and reconnect it.
3	Paper feeding roller worn out	Replace the paper feeding kit.
4	Low voltage power supply PCB ASSY failure	Replace the low voltage power supply PCB ASSY.
5	Main PCB failure	Replace the main PCB ASSY.
6	Registration front/rear sensor PCB ASSY failure	Check the registration front sensor and registration rear sensor performance following the procedure in " <b>Operational Check of Sensors</b> " (Chapter 5). If any problem occurs, replace the regist frame ASSY.

- **Jam inside/Jam rear**

Paper jam inside and rear of the printer

**User Check**

- Check if the paper is jammed inside and rear side of the printer.  
If jammed, remove it.
- Check if the back cover is closed certainly.
- Remove the protective material of the bottom side of the drum unit.

Step	Cause	Remedy
1	Registration front actuator catching on some position	Correct catching of the registration front actuator.
2	Registration rear actuator or paper eject actuator catching on some position	Correct catching of the registration rear actuator or paper eject actuator.
3	Harness connection failure of registration front/rear sensor PCB ASSY or paper eject sensor PCB ASSY	Check the harness connection of the registration front/rear sensor PCB ASSY or paper eject sensor PCB ASSY, and reconnect it.
4	REG clutch ASSY failure	Replace the REG clutch ASSY.
5	Paper eject sensor PCB ASSY failure	Check the sensor performance following the procedure in "Operational Check of Sensors" (Chapter 5). If any problem occurs, replace the paper eject sensor PCB ASSY.
6	Low voltage power supply PCB ASSY failure	Replace the low voltage power supply PCB ASSY.
7	Main PCB failure	Replace the main PCB ASSY.
8	Fuser unit failure	Replace the fuser unit.
9	Registration front/rear sensor PCB ASSY failure	Check the sensor performance following the procedure in "Operational Check of Sensors" (Chapter 5). If any problem occurs, replace the regist frame ASSY.

Waves in the paper / folds in the paper at the eject roller

**User Check**

- Check that the problem is solved if new paper is used.

Step	Cause	Remedy
1	Foreign object around eject roller	Remove the foreign object around the eject roller.
2	Eject roller failure	Replace the top cover ASSY.

- **Duplex unit**

Paper jam in the duplex tray

**User Check**

- Insert the duplex tray correctly.
- Check if the paper is jammed in the duplex tray.

Step	Cause	Remedy
1	Foreign object around duplex tray	Remove the foreign object around the duplex tray.
2	Duplex tray failure	Replace the duplex tray.
3	DX gears damaged	Replace the main frame L ASSY.

#### 4.1.6 Dirt on paper

**User Check**

- Check if the paper is loaded into the paper tray correctly.
- Replace the toner cartridge with a new one.

Step	Cause	Remedy
1	Fuser unit dirty	Clean the entrance of the fuser unit, or clean the pressure roller.

#### 4.1.7 Paper feeding at an angle

**User Check**

- Check if the paper is loaded into the paper tray correctly.
- Adjust the paper guide corresponding to the paper size.
- Check if too much paper is loaded in the tray.
- Check if the thickness of the paper is 60 to 105 g/m<sup>2</sup>.
- Remove the protective sheet of the bottom side of the drum unit.

Step	Cause	Remedy
1	Main PCB failure	Replace the main PCB ASSY.

## 4.1.8 Wrinkles or creases

### User Check

- Check if the paper is no damp.
- Check if the paper is loaded into the paper tray correctly.
- Check if the thickness of the paper is 60 to 105 g/m<sup>2</sup>.
- Turn over the stack of paper in the paper tray, or try rotating the paper 180° in the paper tray.
- Turn the green envelope levers to the direction of the black arrow. (Refer to [Fig. 2-6.](#))

Step	Cause	Remedy
1	Foreign object inside fuser unit	Remove the foreign object inside the fuser unit.
2	Fuser unit failure	Replace the fuser unit.

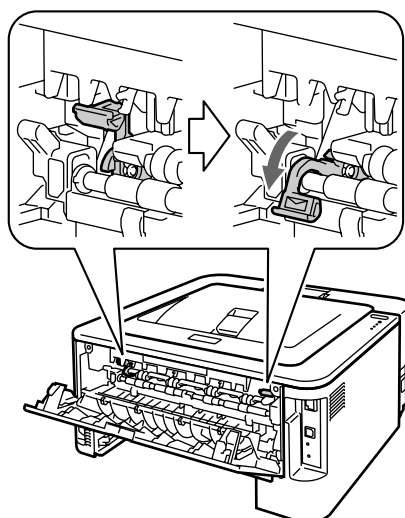


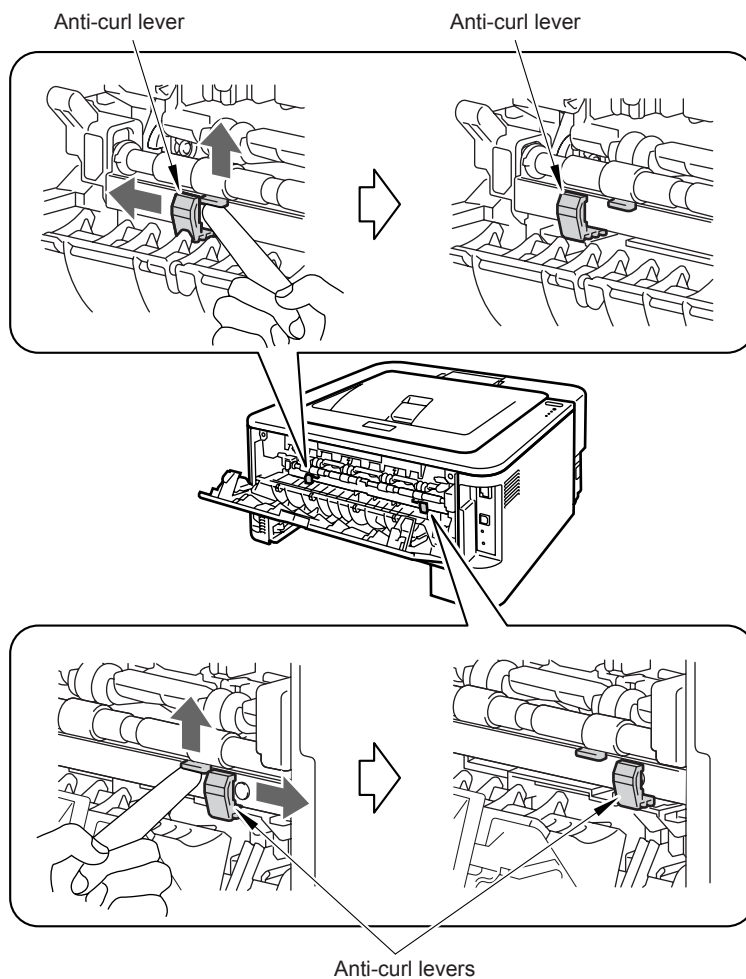
Fig. 2-6

### 4.1.9 Curl in the paper

#### User Check

- Choose Reduce Paper Curl mode in the driver.
- Turn the anti-curl levers to the direction of the black arrow. (Refer to Fig. 2-7.)
- Lift up the support flap2, and then print.

Step	Cause	Remedy
1	Fuser unit failure	Replace the fuser unit.



**Fig. 2-7**

#### 4.1.10 Prints only single side of the paper when duplex-printing

##### User Check

- Set the driver setting to the duplex-printing.
- Use the paper of the A4/LETTER.

#### 4.1.11 Cannot make print through duplex-printing

##### User Check

- Check if the back cover is closed certainly.
- Set the driver setting to the duplex-printing.
- Insert the duplex tray correctly.

Step	Cause	Remedy
1	Harness connection failure of paper eject sensor PCB ASSY	Check the harness connection of the paper eject sensor PCB ASSY, and reconnect it.
2	Duplex tray failure	Replace the duplex tray.
3	Back cover sensor failure	Replace the paper eject sensor PCB ASSY.
4	Main PCB failure	Replace the main PCB ASSY.
5	DX gears damaged	Replace the main frame L ASSY.

#### 4.1.12 Paper size error

##### User Check

- Load the specified paper size into the tray.

Step	Cause	Remedy
1	Registration front actuator catching on some position	Correct catching of the registration front actuator.
2	Main PCB failure	Replace the main PCB ASSY.

#### 4.1.13 Paper size error through duplex-printing

##### User Check

- Load the specified paper size into the tray.

Step	Cause	Remedy
1	Registration front actuator catching on some position	Correct catching of the registration front actuator.
2	Main PCB failure	Replace the main PCB ASSY.

## 4.2 Troubleshooting Image Defect

Image defect related problems are end user recoverable if following the User Check items. If the same problem occurs, follow each procedure in the order of the number described in the Step column in the tables below.

### 4.2.1 Light



#### User Check

- Check the printer's environment. High temperature and high humidity or low temperature and low humidity conditions can cause this problem.
- If the whole page is light, toner save mode may be on. Off the toner save mode.
- Adjust the density by the Density Adjustment.
- Replace the drum unit with a new one.
- Replace the toner cartridge with a new one. If remove the used toner cartridge and replace a relatively new used toner cartridge, this case is caused.

Step	Cause	Remedy
1	Dirt on electrodes of the drum unit and printer body	Clean the electrodes of the drum unit and printer body. (Refer to <a href="#">Fig. 2-8</a> , <a href="#">Fig. 2-9</a> .)
2	Develop bias failure	Reset the counter of develop roller.
3	High voltage power supply PCB ASSY failure	Replace the high voltage power supply PCB ASSY.
4	Main PCB failure	Replace the main PCB ASSY.
5	Laser unit failure	Replace the laser unit.

■ **Electrodes location of the toner cartridge and drum unit**

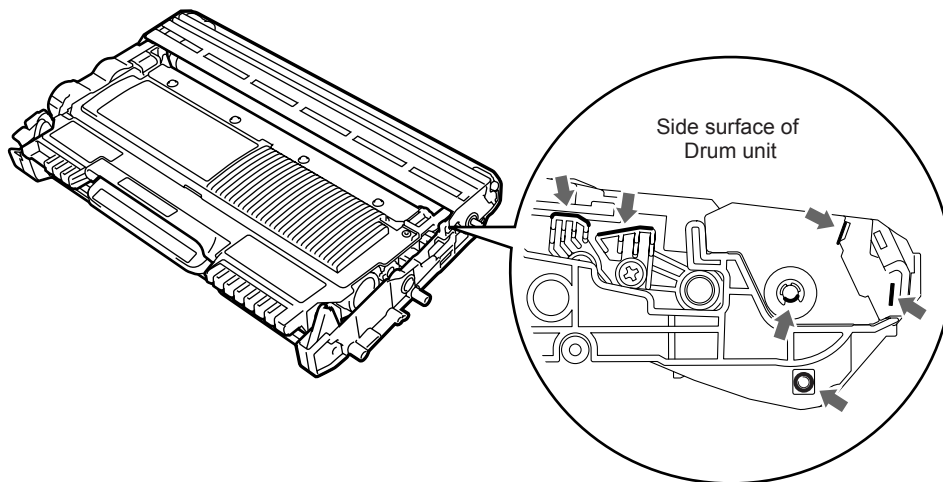


Fig. 2-8

■ **Electrodes location of the printer**

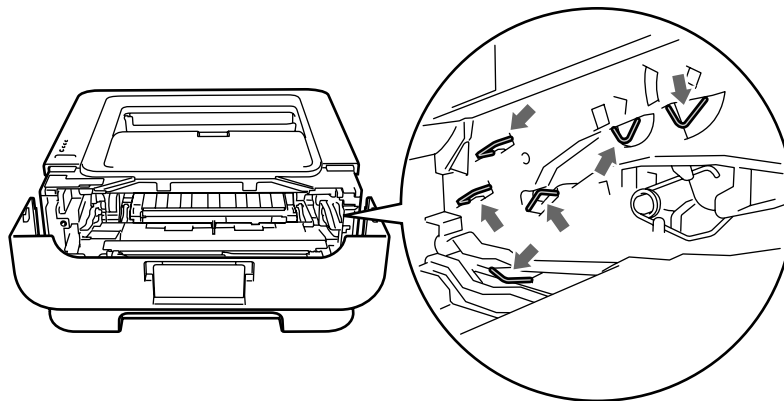


Fig. 2-9

**<How to clean the electrodes>**

Turn off the power switch. Unplug the printer from the AC power outlet, and leave the printer for a few minutes. Then, wipe the electrodes above carefully with a dry lint-free cloth. Be careful not to change the shapes of the electrodes.

## 4.2.2 Faulty registration



### User Check

- Check that the appropriate media type is selected in the driver.

Step	Cause	Remedy
1	Adjusted value of the laser unit mistake	Refer to "2.1 Inputting the adjusted value of the laser unit" (Chapter 4), and enter the adjusted value of the laser unit again.
2	Registration rear actuator catching on some position	Correct catching of the registration rear actuator.

## 4.2.3 Dark

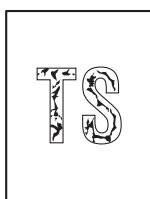


### User Check

- Check the printer's environment. High temperature and high humidity or low temperature and low humidity conditions can cause this problem.
- Adjust the density by the Density Adjustment.
- Clean the corona wire of drum unit.
- Replace the drum unit with a new one.
- Replace the toner cartridge with a new one. If remove the used toner cartridge and replace a relatively new used toner cartridge, this case is caused.

Step	Cause	Remedy
1	Dirt on the electrodes of the drum unit and the printer body	Clean the electrodes of the drum unit and printer body. (Refer to Fig. 2-8, Fig. 2-9.)
2	High voltage power supply PCB ASSY failure	Replace the high voltage power supply PCB ASSY.
3	Main PCB failure	Replace the main PCB ASSY.
4	Laser unit failure	Replace the laser unit.

## 4.2.4 Poor fixing

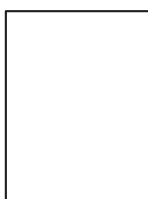


### User Check

- Check the printer's environment. High temperature and high humidity or low temperature and low humidity conditions can cause this problem.
- Clean the corona wire of drum unit.
- Replace the drum unit with a new one.
- Replace the toner cartridge with a new one.
- Return the green envelope levers to the home position. (Refer to [Fig. 2-6.](#))

Step	Cause	Remedy
1	Fuser unit failure	Replace the fuser unit.
2	Laser unit failure	Replace the laser unit.
3	Low voltage power supply PCB ASSY failure	Replace the low voltage power supply PCB ASSY.
4	Main PCB failure	Replace the main PCB ASSY.

## 4.2.5 Completely blank



### User Check

- Check the printer's environment. High temperature and high humidity or low temperature and low humidity conditions can cause this problem.
- Clean the corona wire of drum unit.
- Replace the drum unit with a new one.
- Replace the toner cartridge with a new one.
- Remove the elastic band from the drum unit.

Step	Cause	Remedy
1	Dirt on the electrodes of the drum unit and the printer body	Clean the electrodes of the drum unit and printer body. (Refer to <a href="#">Fig. 2-8</a> , <a href="#">Fig. 2-9.</a> )
2	Scanner harness of the laser unit connection failure	Reconnect the scanner harness of the laser unit.
3	Laser unit not assembled correctly	Assemble the laser unit correctly and secure the screw.
4	Laser unit failure	Replace the laser unit.
5	High voltage power supply PCB ASSY failure	Replace the high voltage power supply PCB ASSY.
6	Main PCB failure	Replace the main PCB ASSY.

## 4.2.6 Image distortion



Step	Cause	Remedy
1	Laser unit not assembled correctly	Assemble the laser unit correctly and secure the screw.
2	Laser unit failure	Replace the laser unit.
3	Main PCB failure	Replace the main PCB ASSY.

## 4.2.7 All black



### User Check

- Clean the corona wire of drum unit.
- Replace the drum unit with a new one.

Step	Cause	Remedy
1	Dirt on drum unit and printer body electrodes	Clean the electrodes of the drum unit and printer body. (Refer to Fig. 2-8, Fig. 2-9.)
2	Scanner harness of the laser unit connection failure	Reconnect the scanner harness of the laser unit.
3	FG plate connection failure	Reconnect the FG plate between the laser unit and develop drive sub ASSY securely, and secure the screw.
4	High voltage power supply PCB ASSY failure	Replace the high voltage power supply PCB ASSY.
5	Main PCB failure	Replace the main PCB ASSY.
6	Laser unit failure	Replace the laser unit.

## 4.2.8 The back of paper gets dirty



### User Check

- This problem may disappear after printing approximately 10 pages of completely blank sheets.

Step	Cause	Remedy
1	Dirt on the fuser unit	Replace the fuser unit.
2	Dirt in the paper feed system	Wipe dirt off.

## 4.2.9 Vertical streaks



### User Check

- This problem may occur with noise which is caused by dirt on the corona wire in the drum unit. In this case, clean the corona wire.
- If the same problem occurs after printing a few pages, the adhesive of the label or the like, paper powder or dirt may be attached on the surface of the exposure drum. Wipe off the dirt on the exposure drum. (Refer to User's guide, and perform the Drum Cleaning.)
- Replace the drum unit with a new one.
- Replace the toner cartridge with a new one.

Step	Cause	Remedy
1	Dirt in the paper feed system	Wipe dirt off.
2	Dirt on the heat roller	Clean the heat roller in the following procedures.
3	Scratch on the heat roller	Replace the fuser unit.

### **CAUTION :**

- If the printer prints the same pattern, especially including vertical streaks, continuously, black vertical streaks may appear on the paper since the electrostatic performance of the exposure drum is decreased temporarily.

### ■ How to clean the heat roller

- (1) Make the black pattern as shown in the figure below by the Word, PowerPoint or other applications and print it.



100% Black  
All-black

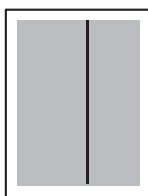
- (2) Put the paper that is printed in the procedure (1) into the paper tray. The printed side must be face down.
- (3) Make the white pattern as shown in the figure below by the Word, PowerPoint or other applications and print it.



100% White  
All-white (Blank page)

- (4) Print any image, and check whether there is any dirt on the paper.
- (5) If there is still the dirt, repeat the procedure (2) to (4).
- (6) If the dirt is not removed after repeating the procedure (2) to (4) several times, replace the fuser unit.

## 4.2.10 Black vertical streaks in a light background



### User Check

- Clean the inside of the printer and the corona wire in the drum unit.
- Replace the drum unit with a new one.
- Replace the toner cartridge with a new one.

## 4.2.11 Black horizontal stripes



### User Check

- Clean the inside of the printer and the corona wire in the drum unit.
- When the horizontal stripes at 94.2 mm are intervals, replace the drum unit with a new one.
- The paper tray ground terminal provided in the printer body may be dirty. Clean the contact with a dry cloth.

Step	Cause	Remedy
1	Dirt on the electrodes of the drum unit and the printer body	Clean the electrodes of the drum unit and printer body. (Refer to Fig. 2-8, Fig. 2-9.)
2	Bend of tray ground spring	(1) Correct bending of the tray ground spring. (2) Replace the paper tray.
3	Toner attached on the develop roller (horizontal stripes at 32.5 mm)	This problem will disappear by printing approximate 10 pages. If the same problem occurs, replace the toner cartridge.
4	Scratch and Dirt on the heat roller (horizontal stripes at 53.4 mm)	Replace the fuser unit.
5	High voltage power supply PCB ASSY failure	Replace the high voltage power supply PCB ASSY.
6	Main PCB failure	Replace the main PCB ASSY.

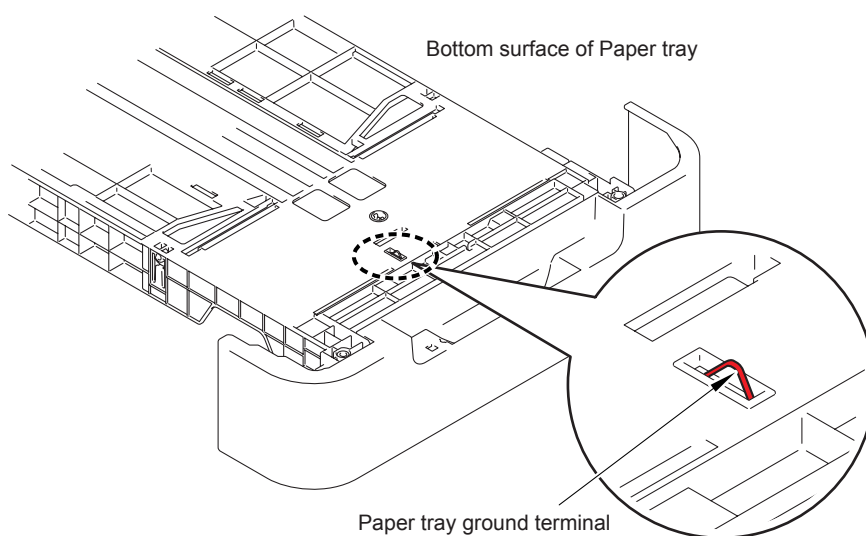


Fig. 2-10

### CAUTION :

- Image defects which appear periodically may be caused by failure of a roller. Specify the cause referring to the diameter of the rollers or pitch which appears in the image as shown in the table below

No.	Parts name	Diameter	The pitch which appears in the image
1	Develop roller	Ø16 mm	32.5 mm
2	Exposure drum	Ø30 mm	94.2 mm
3	Heat roller in the fuser unit	Ø17 mm	53.4 mm
4	Pressure roller in the fuser unit	Ø25 mm	78.5 mm

#### 4.2.12 White vertical streaks



##### User Check

- Check if there is no dust in the gap between the toner cartridge and drum unit.
- Replace the toner cartridge with a new one.
- Check the printer's environment. High temperature and high humidity or low temperature and low humidity conditions can cause this problem.
- Damp (wet) paper might be used. Try to change to freshly unpacked paper.
- Replace the drum unit with a new one.
- Leave the printer for a while as the power remains ON.

Step	Cause	Remedy
1	Laser unit failure	Replace the laser unit.

#### 4.2.13 White horizontal streaks

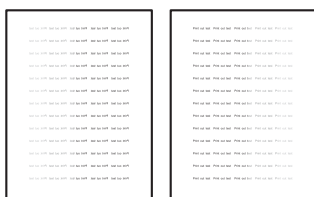


##### User Check

- This problem may disappear If print several sheets of page. Print several sheets of page if the printer has not been used for a long time.
- Replace the drum unit with a new one.
- Replace the toner cartridge with a new one.

Step	Cause	Remedy
1	Dirt on the electrodes of the drum unit and the printer body	Clean the electrodes of the drum unit and printer body. (Refer to <a href="#">Fig. 2-8</a> , <a href="#">Fig. 2-9</a> .)

#### 4.2.14 Faint print

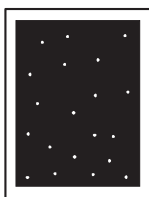


##### User Check

- Check that the printer is installed on a level surface.
- Replace the toner cartridge with a new one.

Step	Cause	Remedy
1	Main PCB failure	Replace the main PCB ASSY.
2	Laser unit failure	Replace the laser unit.
3	Fuser unit failure	Replace the fuser unit.

## 4.2.15 White spots

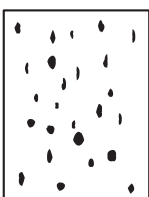


### User Check

- When the white spots at 32.5 mm are intervals, replace the toner cartridge with a new one.
- If the same problem occurs after printing a few pages, the adhesive of the label or the like, paper powder or dirt may be attached on the surface of the exposure drum. Wipe off the dirt on the exposure drum. (Refer to User's guide, and perform the Drum Cleaning.)
- When the white spots at 94.2 mm are intervals, replace the drum unit with a new one.

Step	Cause	Remedy
1	Dirt on the electrodes of the drum unit and the printer body	Clean the electrodes of the drum unit and printer body. (Refer to <a href="#">Fig. 2-8</a> , <a href="#">Fig. 2-9</a> .)
2	High voltage power supply PCB ASSY failure	Replace the high voltage power supply PCB ASSY.
3	Main PCB failure	Replace the main PCB ASSY.

## 4.2.16 Black spots



### User Check

- When the black spots at 32.5 mm are intervals, replace the toner cartridge with a new one.
- If the same problem occurs after printing a few pages, the adhesive of the label or the like, paper powder or dirt may be attached on the surface of the exposure drum. Wipe off the dirt on the exposure drum. (Refer to User's guide, and perform the Drum Cleaning.)
- When the black spots at 94.2 mm are intervals, replace the drum unit with a new one.

Step	Cause	Remedy
1	Dirt on the electrodes of the drum unit and the printer body	Clean the electrodes of the drum unit and printer body. (Refer to <a href="#">Fig. 2-8</a> , <a href="#">Fig. 2-9</a> .)
2	Dirt on the heat roller	Refer to " <a href="#">2-34 How to clean the heat roller</a> ", and clean the heat roller.
3	Scratch and Dirt on the heat roller (Black spots at 53.4 mm)	Replace the fuser unit.
4	High voltage power supply PCB ASSY failure	Replace the high voltage power supply PCB ASSY.
5	Main PCB failure	Replace the main PCB ASSY.

#### 4.2.17 Black band



##### User Check

- Clean the inside of the printer and the corona wire in the drum unit. If the same problem occurs after cleaning, replace the drum unit with a new one.
- The paper tray ground terminal provided in the printer body may be dirty. Clean the contact with a dry cloth.

Step	Cause	Remedy
1	Bend of tray ground spring	(1) Correct bending of the tray ground spring. (2) Replace the paper tray.

#### 4.2.18 Downward fogging of solid black

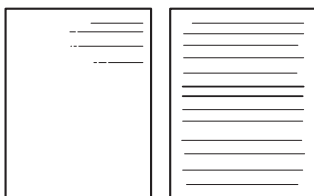


##### User Check

- Replace the toner cartridge with a new one.

Step	Cause	Remedy
1	High voltage power supply PCB ASSY failure	Replace the high voltage power supply PCB ASSY.
2	Main PCB failure	Replace the main PCB ASSY.

#### 4.2.19 Horizontal lines



##### User Check

- The paper tray ground terminal provided in the printer body may be dirty. Clean the contact with a dry cloth.
- Replace the drum unit with a new one.
- Replace the toner cartridge with a new one.

Step	Cause	Remedy
1	Dirt on the electrodes of the drum unit and the printer body	Clean the electrodes of the drum unit and printer body. (Refer to <a href="#">Fig. 2-8</a> , <a href="#">Fig. 2-9</a> .)
2	Bend of tray ground spring	(1) Correct bending of the tray ground spring. (2) Replace the paper tray.
3	Laser unit failure	Replace the laser unit.
4	Scratch and Dirt on the heat roller (horizontal stripes at 53.4 mm)	Replace the fuser unit.

#### 4.2.20 Ghost



##### User Check

- Check the printer's environment. High temperature and high humidity or low temperature and low humidity conditions can cause this problem.
- Choose Reduce Ghosting mode in the driver.
- Replace the toner cartridge with a new one.

Step	Cause	Remedy
1	High voltage power supply PCB ASSY failure	Replace the high voltage power supply PCB ASSY.
2	Main PCB failure	Replace the main PCB ASSY.

#### 4.2.21 Fogging



##### User Check

- This problem may disappear after printing approximately 10 pages of completely blank sheets.
- Replace the drum unit with a new one.
- Replace the toner cartridge with a new one.
- Do not use acid paper.

Step	Cause	Remedy
1	High voltage power supply PCB ASSY failure	Replace the high voltage power supply PCB ASSY.
2	Main PCB failure	Replace the main PCB ASSY.

##### **CAUTION :**

- This problem often occurs when the drum unit or toner cartridge is nearly at the end of life.

## 4.3 Software Setting Problems

The end user can solve problems pertaining to software, for instance, print cannot be made from a computer although test print and Printer Settings print can be made from the printer, by following the User Check items. If the same problem occurs, follow each procedure in the order of the number described in the Step column in the tables below.

### 4.3.1 Cannot print data

#### User Check

- Check that the USB cable or LAN cable is not damaged.
- Check that the correct printer is selected if you have an interface switching device.
- Check the descriptions on the software setting in the user's guide.
- Reset the printer back to its default printer settings.  
(Refer to "Settings Reset" in Chapter 5.)

Step	Cause	Remedy
1	Printer connection	For Macintosh, check the product ID*. When it is wrong, update the firmware.
2	Main PCB failure	Replace the main PCB ASSY.

\* Check the product ID of Macintosh as follows:

- (1) Select the "About This Mac" from the "Apple" menu.
- (2) Press the "More Info..." button within the "About This Mac" dialogue.
- (3) Select the "USB" at the bottom of "Hardware" in left side "Content".
- (4) Select the "HL-XXXX" in the "USB Device Tree".
- (5) Check the "Product ID" in the "HL-XXXX".

Product ID (Hexadecimal)

- HL-2130 : 003Fh
- HL-2220 : 0046h
- HL-2230 : 0044h
- HL-2240 : 0045h
- HL-2240D : 0040h
- HL-2250DN : 0041h
- HL-2270DW : 0042h

## 4.4 Network Problems (Network model only)

### 4.4.1 Cannot make a print through network connection

#### User Check

- Check the descriptions in the network user's guide.
- Reset the printer back to its default printer settings.  
(Refer to "Settings Reset" in Chapter 5.)
- Check the connection of the network.

Step	Cause	Remedy
1	Harness connection failure of wireless LAN PCB (HL-2270DW only)	Reconnect the harness of the wireless LAN PCB.
2	Wireless LAN PCB failure (HL-2270DW only)	Replace the wireless LAN PCB ASSY.
3	Main PCB failure	Replace the main PCB ASSY.

## 4.5 Toner & Drum Problems

### 4.5.1 If replace toner, cannot delete "Replace Toner".

#### User Check

- Install a new toner cartridge certainly.

Step	Cause	Remedy
1	New toner actuator catching on some position	Correct catching of the new toner actuator.
2	Harness connection failure of Panel PCB	Reconnect the harness of the Panel PCB.
3	Panel PCB failure	Replace the panel PCB ASSY.
4	Main PCB failure	Replace the main PCB ASSY.

### 4.5.2 Cannot detect toner

Identification failure for a new toner cartridge

Step	Cause	Remedy
1	Power off or front cover opened while detecting a new toner cartridge.	Reset the developing bias voltage and develop roller counter.
2	New toner actuator loose	Re-assemble the new toner actuator
3	New toner sensor failure	Replace the panel PCB ASSY.

### 4.5.3 Toner low

Toner is low

#### User Check

- Prepare a new toner cartridge.

Step	Cause	Remedy
1	Main PCB failure	Replace the main PCB ASSY.

### 4.5.4 Replace toner

#### User Check

- Replace the toner cartridge with a new one.
- Press the [Go] button seven times to clear the stop mode\*, and shift to the continue mode.

Step	Cause	Remedy
1	Main PCB failure	Replace the main PCB ASSY.

\* When the printer is in the stop mode, LEDs indicate REPLACE TONER to guarantee the print quality. On the other hand, when the continue mode is turned on, the end user can choose either to continue printing or replace the toner cartridge with a new one.

#### 4.5.5 The number of rotations of the developer roller reaches the upper limit

##### User Check

- Replace the toner cartridge with a new one.

Step	Cause	Remedy
1	New toner actuator loose (If replace the new toner, "TONER ENDED" does not disappear.)	Re-assemble the new toner actuator
2	Install the used toner to printer (If replace the new toner, "TONER ENDED" does not disappear.)	Reset the develop roller counter.
3	Main PCB failure	Replace the main PCB ASSY.

#### 4.5.6 No toner

##### User Check

- Install the toner cartridge.

Step	Cause	Remedy
1	Dirt on the electrodes of the drum unit and the printer body	Clean the electrodes of the drum unit and printer body. (Refer to <a href="#">Fig. 2-8</a> , <a href="#">Fig. 2-9</a> .)
2	Harness connection failure of high voltage power supply PCB	Check the harness connection of high voltage power supply PCB and reconnect it.
3	High voltage power supply PCB ASSY failure	Replace the high voltage power supply PCB ASSY.
4	Main PCB failure	Replace the main PCB ASSY.

#### 4.5.7 Drum life end soon

Replacing of drum unit

##### User Check

- Prepare a new drum unit.

#### 4.5.8 Drum error

Dirt on drum unit

##### User Check

- Clean the corona wire in the drum unit.
- Replace the drum unit with a new one, and reset the drum counter.

Step	Cause	Remedy
1	Dirt on the electrodes of the drum unit and the printer body	Clean the electrodes of the drum unit and printer body. (Refer to <a href="#">Fig. 2-8</a> , <a href="#">Fig. 2-9</a> .)
2	High voltage power supply PCB ASSY failure	Replace the high voltage power supply PCB ASSY.
3	Main PCB failure	Replace the main PCB ASSY.

#### 4.5.9 Drum stop

##### User Check

- Replace the drum unit with a new one, and reset the drum counter.

## 4.6 Fuser Unit Problems

### 4.6.1 Fuser Unit failure

Step	Cause	Remedy
1	Harness connection failure between fuser unit connector and paper eject sensor PCB ASSY	Check the harness connection between fuser unit connector and paper eject sensor PCB ASSY, and reconnect it.
2	Harness connection failure between fuser unit connector and low voltage power supply PCB ASSY	Check the harness connection between fuser unit connector and low voltage power supply PCB ASSY, and reconnect it.
3	Harness connection failure between paper eject sensor PCB ASSY and main PCB.	Check the harness connection between paper eject sensor PCB ASSY and main PCB, and reconnect it.
4	Paper eject sensor PCB ASSY failure	Replace the paper eject sensor PCB ASSY.
5	Low voltage power supply PCB ASSY failure	Replace the low voltage power supply PCB ASSY.
6	Main PCB failure	Replace the main PCB ASSY.
7	Fuser unit failure	Replace the fuser unit.

#### CAUTION :

- Turn off the power switch once, and after checking that the fuser unit sufficiently cools down, turn on the power switch again and leave the printer for ten minutes. Then, this problem may be cleared.

Turn the power on while pressing the [Go] button, when the front cover is open. After Toner, Drum and Error LEDs light up, release the [Go] button. Check that all LEDs go off, press the [Go] button once, and after all LEDs light up again, press the [Go] button once again. Then, this problem may be cleared. However, be careful because the fuser unit melts if the fuser unit does not sufficiently cool down.

## 4.7 Laser Unit Problems

### 4.7.1 Laser Unit failure

#### User Check

- There is a possibility that the condensation has occurred. Turn off the power, and leave the machine at least one hour in a well-ventilated place. And then turn on the power.

Step	Cause	Remedy
1	Harness connection failure of laser unit	Check the harness connection of the laser unit, and reconnect them.
2	Main PCB failure	Replace the main PCB ASSY.
3	Laser unit failure	Replace the laser unit.

## 4.8 PCB Problems

### 4.8.1 Main PCB failure

#### User Check

- Turn the power off and on.

Step	Cause	Remedy
1	Firmware update failure	Rewrite the latest firmware.
2	Main PCB failure	Replace the main PCB ASSY.

### 4.8.2 Memory full

Memory full

#### User Check

- Press the [Go] button, then print the stored data.
- Reduce the data capacity or reduce the print resolution.

Step	Cause	Remedy
1	Main PCB failure	Replace the main PCB ASSY.

### 4.8.3 Print overrun

Data expansion is not in time

#### User Check

- Reduce the data capacity or reduce the print resolution.

Step	Cause	Remedy
1	Main PCB failure	Replace the main PCB ASSY.

### 4.8.4 High voltage power supply PCB ASSY failure

Step	Cause	Remedy
1	Harness connection failure of high voltage power supply PCB ASSY	Check the harness connection between the high voltage power supply PCB ASSY and main PCB, and reconnect it.
2	High voltage power supply PCB ASSY failure	Replace the high voltage power supply PCB ASSY.
3	Low voltage power supply PCB ASSY failure	Replace the low voltage power supply PCB ASSY.
4	Main PCB failure	Replace the main PCB ASSY.

## 4.8.5 Low voltage power supply PCB ASSY failure

### User Check

- Turn the power off and on.

Step	Cause	Remedy
1	Harness connection failure of low voltage power supply PCB ASSY	Check the harness connection of the low voltage power supply PCB ASSY, and reconnect it.
2	Low voltage power supply PCB failure	Replace the low voltage power supply PCB ASSY. Then, reset the irregular power supply detection counter following the procedure described in "3.1 Reset of Irregular Power Supply Detection Counter" in Chapter 4.
3	Main PCB failure	Replace the main PCB ASSY.

### **CAUTION :**

- The irregular power supply detection error (After blinking the Toner/Drum/Error/Ready LED, the Toner/Drum/Error LED light up by pressing the [Go] button once. ) occurs when there is a large distortion in the power supply voltage supplied to the printer. In this case, if the same power supply is used, the same error may occur even when the low voltage power supply PCB ASSY is replaced. Ask the user to review the installation environment.

## 4.9 Other Problems

### 4.9.1 The printer is not turned on, or the LED indication does not appear.

#### User Check

- Replace the AC power cord.

Step	Cause	Remedy
1	Harness connection failure of panel PCB ASSY	Reconnect the harness of the panel PCB ASSY correctly.
2	Panel PCB failure	Replace the panel PCB ASSY.
3	Low voltage power supply PCB ASSY failure	Replace the low voltage power supply PCB ASSY.
4	Main PCB failure	Replace the main PCB ASSY.

### 4.9.2 Fuser fan does not rotate.

Step	Cause	Remedy
1	Harness connection failure of the fuser fan	Reconnect the harness of the fuser fan correctly.
2	Fuser fan failure	Replace the fuser fan.
3	Harness connection failure of high voltage power supply PCB	Reconnect the harness of the high voltage power supply PCB ASSY.
4	High voltage power supply PCB ASSY failure	Replace the high voltage power supply PCB ASSY.
5	Main PCB failure	Replace the main PCB ASSY.

### 4.9.3 Main motor failure

Step	Cause	Remedy
1	Flat cable connection failure of the main motor	Check the flat cable connection of the main motor, and reconnect it.
2	Main motor failure	Replace the main motor.
3	Low voltage power supply PCB ASSY failure	Replace the low voltage power supply PCB ASSY.
4	Main PCB failure	Replace the main PCB ASSY.

### 4.9.4 Front cover open

Front cover opened

#### User Check

- Check if the front cover is closed certainly.

Step	Cause	Remedy
1	Harness connection failure of high voltage power supply PCB ASSY (Front cover sensor is mounted in high voltage power supply PCB ASSY.)	Check the harness connection of the high voltage power supply PCB ASSY, and reconnect it.
2	Part pressing the front cover sensor is broken, which is provided at inside of front cover	Replace the front cover ASSY.
3	Front cover sensor failure	Check the registration front sensor and registration rear sensor performance following the procedure in "Operational Check of Sensors" (Chapter 5). If any problem occurs, replace the high voltage power supply PCB ASSY.
4	Main PCB failure	Replace the main PCB ASSY.

### 4.9.5 Back cover open

Back cover opened

#### User Check

- Check if the back cover is closed certainly.
- Install the duplex tray certainly.

Step	Cause	Remedy
1	Harness connection failure of paper eject sensor PCB ASSY	Check the harness connection of the paper eject sensor PCB ASSY, and reconnect it.
2	Part pressing the back cover sensor is broken, which is provided at inside of back cover	Replace the back cover ASSY.
3	Part pressing the back cover sensor is broken, which is provided at inside of duplex tray	Replace the duplex tray.
4	Back cover sensor failure	Replace the paper eject sensor PCB ASSY.
5	Main PCB failure	Replace the main PCB ASSY.

---


## CHAPTER 3 DISASSEMBLY AND ASSEMBLY

---

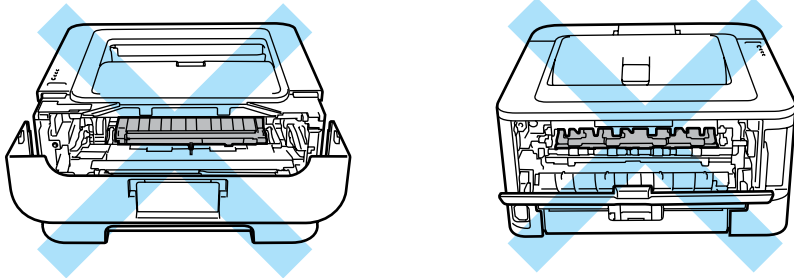
### 1. SAFETY PRECAUTIONS

---

To avoid creating secondary problems by mishandling, follow the warnings and precautions below during maintenance work.

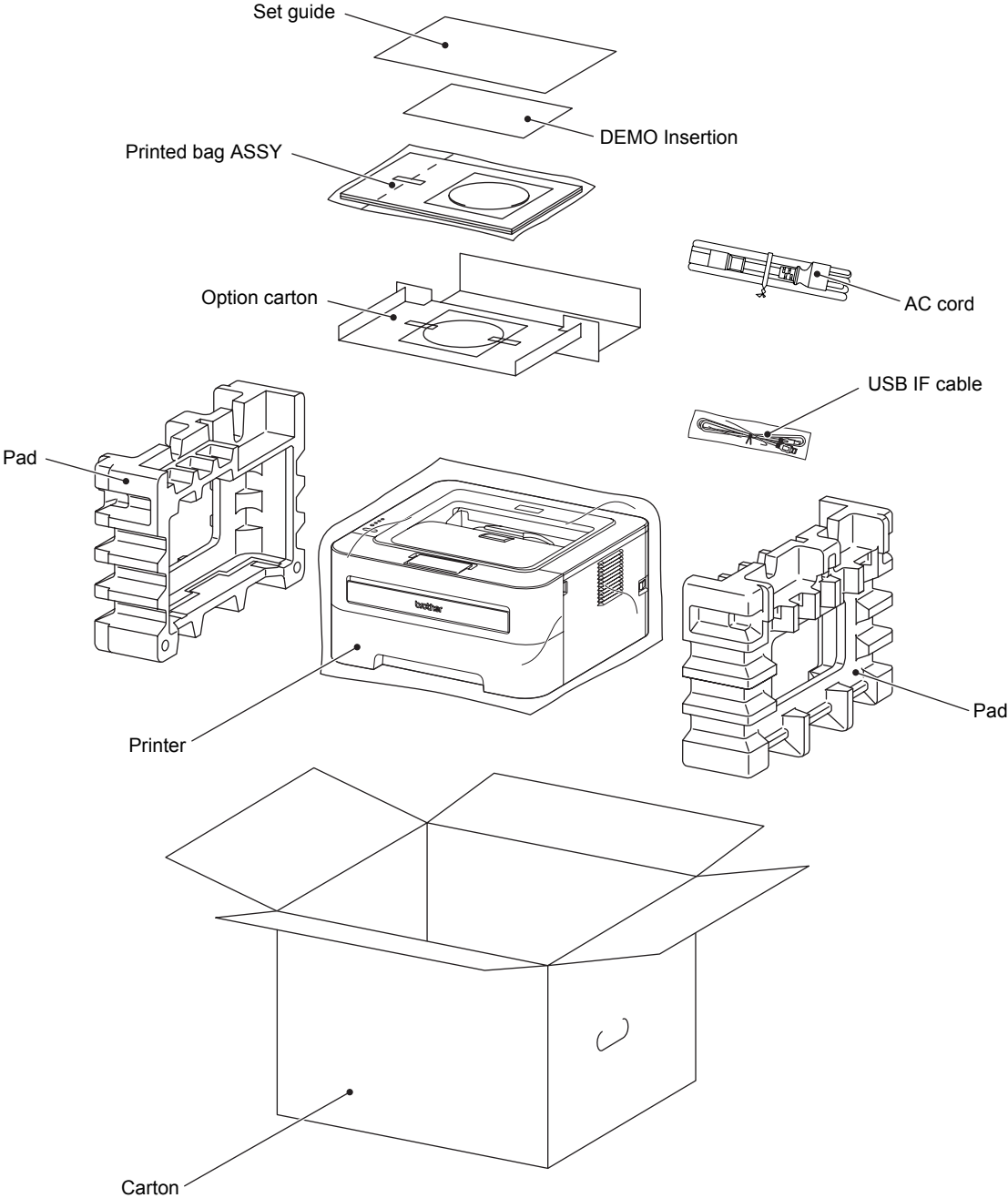
 **WARNING**

- Always turn off the power switch and unplug the power cord from the power outlet before accessing any parts inside the printer.
- When opening the front cover or back cover to access any parts inside the printer, never touch the shaded parts shown in the following figures.
- DO NOT use flammable substances such as alcohol, benzene, thinner or any type of spray to clean the inside or outside of the printer. Doing this may cause a fire or electrical shock.



- Be careful not to lose screws, washers, or other parts removed.
- Be sure to apply grease to the gears and applicable positions specified in this chapter.
- When using soldering irons or other heat-generating tools, take care not to accidentally damage parts such as wires, PCBs and covers.
- Static electricity charged in your body may damage electronic parts. When transporting PCBs, be sure to wrap them in conductive sheets.
- When replacing the PCB and all the other related parts, put on a grounding wrist band and perform the job on a static mat. Also take care not to touch the conductor sections on the flat cables or on the wire harness.
- When connecting or disconnecting cable connectors, hold the connector body, not the cables. If the connector has a lock, release the connector lock first to release it.
- After a repair, check not only the repaired portion but also all connectors. Also check that other related portions are functioning properly before operational checks.
- After disconnecting flat cables, check that each cable is not damaged at its end or short-circuited.
- When connecting flat cables, do not insert them at an angle. After insertion, check that the cables are not at an angle.
- After an assembly, recommend the operation of "dielectric strength voltage check" and "continuity check".

**2. PACKING**



**Fig. 3-1**

### 3. SCREW CATALOGUE

#### Taptite bind B

Taptite bind B M3x10	
Taptite bind B M4x12	

#### Screw bind B

Screw bind M3x4	
--------------------	--

#### Taptite pan B

Taptite pan B M3x8	
Taptite pan B M4x14	

#### Taptite cup B

Taptite cup B M3x8	
-----------------------	--

#### Taptite cup S

Taptite cup S M3x6 SR	
Taptite cup S M3x8 SR	

#### Taptite flat B

Taptite flat B M3x10	
-------------------------	--

#### Screw pan (S/P washer)

Screw pan (S/P washer) M3.5x6	
Screw pan (S/P washer) M3x12DB	

Fig. 3-2

## 4. SCREW TORQUE LIST

Location of screw	Screw type	Q'ty	Tightening torque N · m (kgf · cm)
Tray cover	Taptite bind B M4x12	2	0.8±0.1 (8±1)
Inner chute ASSY	Taptite bind B M4x12	2	0.8±0.1 (8±1)
Top cover base (Top cover ASSY <except for HL-2130>)	Taptite bind B M4x12	2	0.8±0.1 (8±1)
SW key holder (Top cover ASSY <HL-2130>)	Taptite pan B M3x8	1	0.4±0.1 (4±1)
Fuser unit	Taptite pan B M4x14	2	0.8±0.1 (8±1)
LV shield plate cover	Taptite bind B M4x12	3	0.8±0.1 (8±1)
	Screw pan (S/P washer) M3.5x6	1	0.5±0.05 (5±0.5)
	Screw pan (S/P washer) M3x12DB	1	0.5±0.1 (5±1)
Low voltage power supply PCB ASSY	Screw pan (S/P washer) M3.5x6	1	0.5±0.05 (5±0.5)
	Taptite flat B M3x10	1	0.45±0.05 (4.5±0.5)
	Taptite bind B M4x12	1	0.8±0.1 (8±1)
High voltage power supply PCB ASSY	Taptite bind B M4x12	1	0.8±0.05 (8±0.5)
Laser unit	Taptite cup S M3x8 SR	4	0.8±0.05 (8±0.5)
Main PCB ASSY	Taptite cup S M3x6 SR	4	0.6±0.1 (6±1)
Front chute ASSY	Taptite bind B M4x12	2	0.8±0.1 (8±1)
Under bar	Taptite bind B M4x12	1	0.8±0.1 (8±1)
Chute ground plate	Taptite bind B M3x10	1	0.55±0.05 (5.5±0.5)
PF frame ASSY	Taptite bind B M4x12	1	0.8±0.1 (8±1)
FG plate laser L	Taptite cup S M3x6 SR	1	0.8±0.1 (8±1)
Main frame L ASSY	Taptite bind B M4x12	2	0.8±0.1 (8±1)
	Taptite cup S M3x6 SR	2	0.8±0.1 (8±1)
Develop drive sub ASSY	Taptite cup S M3x6 SR	1	0.8±0.1 (8±1)
	Taptite bind B M4x12	3	0.8±0.1 (8±1)
Motor drive sub ASSY	Taptite bind B M4x12	6	0.8±0.1 (8±1)
Main motor	Screw bind M3x4	3	0.65±0.05 (6.5±0.5)
Main PCB shield	Taptite cup S M3x6 SR	1	0.6±0.1 (6±1)
	Taptite bind B M4x12	2	0.8±0.1 (8±1)

## 5. LUBRICATION

The kind of the lubricating oil (Maker name)	Lubrication point	Quantity of lubrication
BG-10KS (Kanto Kasei)	Dev gear joint/52	2mm dia. ball (BG2)

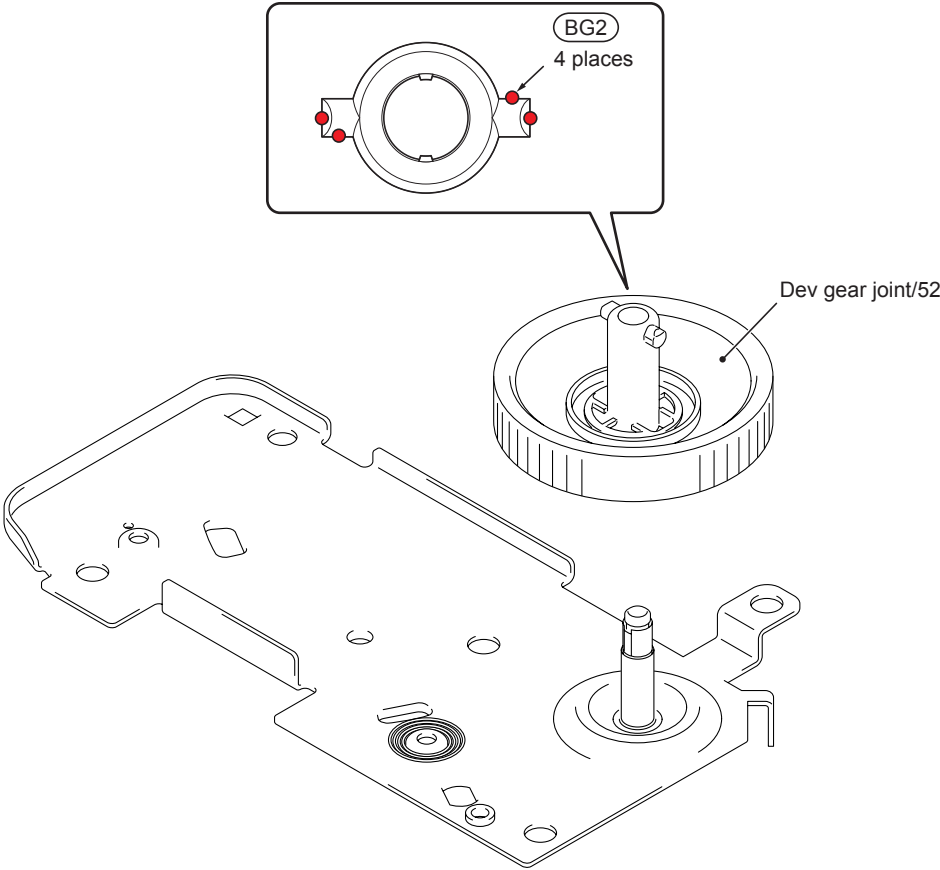


Fig. 3-3

## 6. OVERVIEW OF GEARS

### ■ Paper feeder part

<Development view>

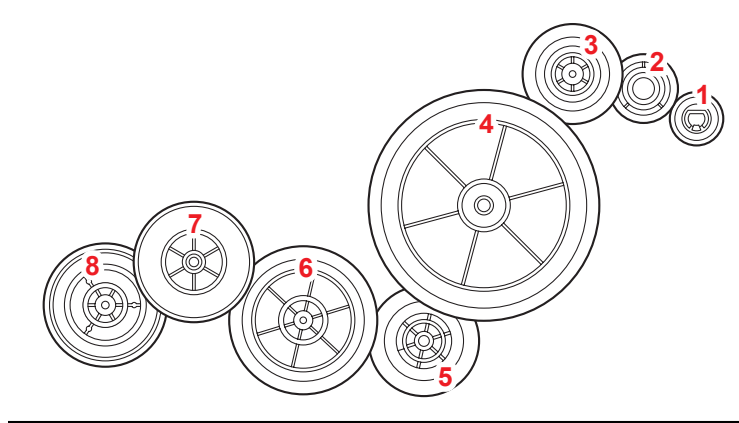


Fig. 3-4

<Layout view>

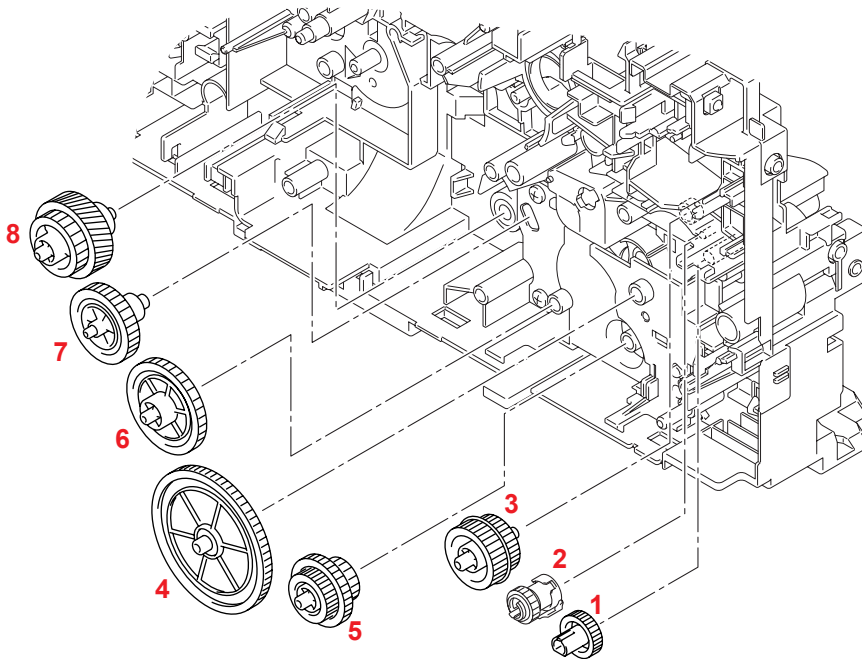


Fig. 3-5

<Name of gears>

1	LY2584	Feeder gear 17	4	LY2046	Feeder gear idle 65
2	LY2047	Feeder gear	5	LY2045	Feeder gear 21/30/17
	LY2581	Feeder gear holder	6	LY2044	Feeder gear 41
	LY2582	Feeder gear spring	7	LY2043	Feeder gear 31 pendulum
	LY2583	Feeder holder spring	8	LY2042	Feeder gear 26/52R
3	LY2048	Feeder gear 24/27			

\* These parts are subject to change without prior notice

■ **Development part**

<Development view>

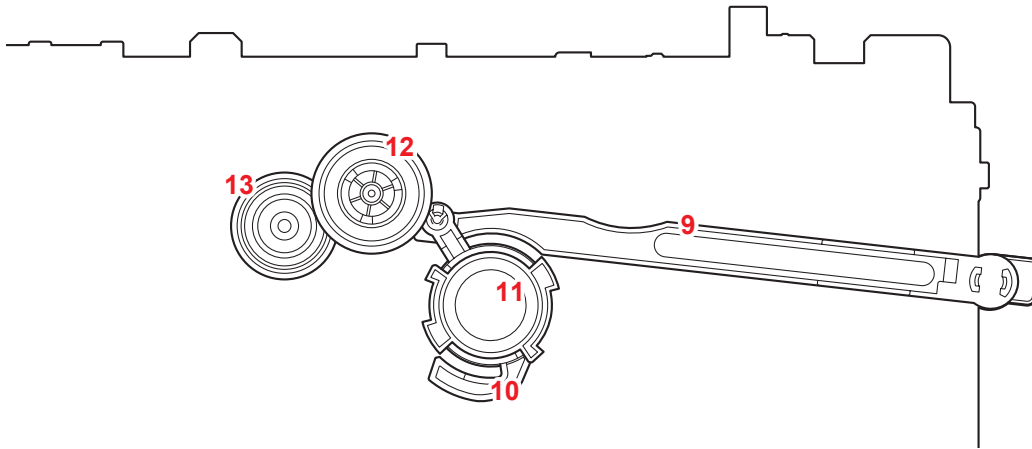


Fig. 3-6

<Layout view>

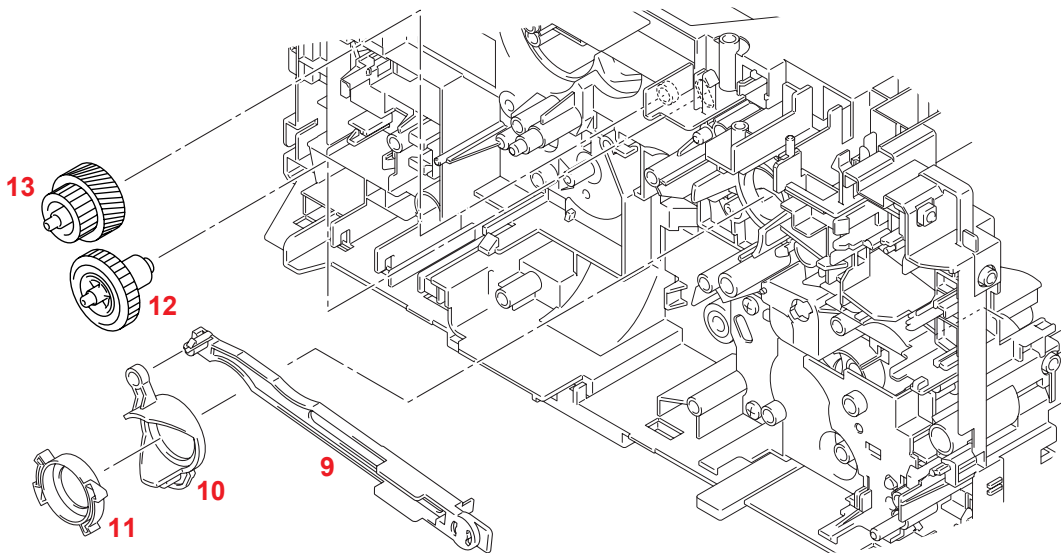


Fig. 3-7

<Name of gears>

9	LY2064	Develop joint link	12	LY2063	DEV gear 33
10	LY2458	Develop joint lift cam	13	LY2062	DEV gear 21/45R
11	LU2041	Develop joint lift disk			

\* These parts are subject to change without prior notice

■ Paper eject & Duplex part

<Development view>

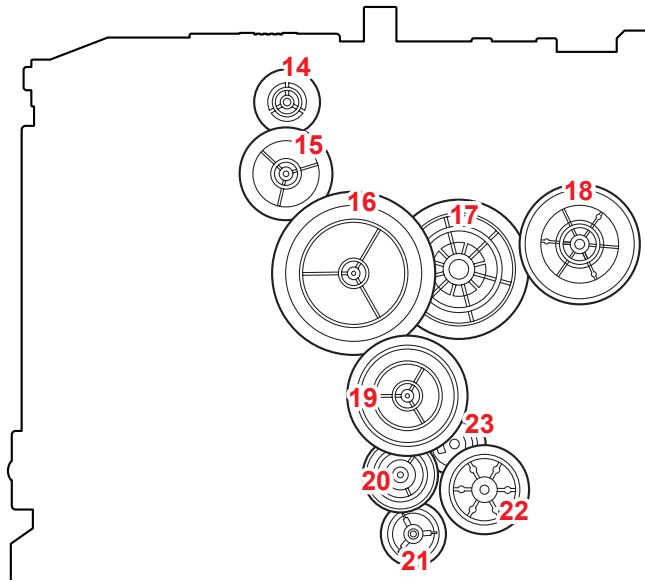


Fig. 3-8

<Layout view>

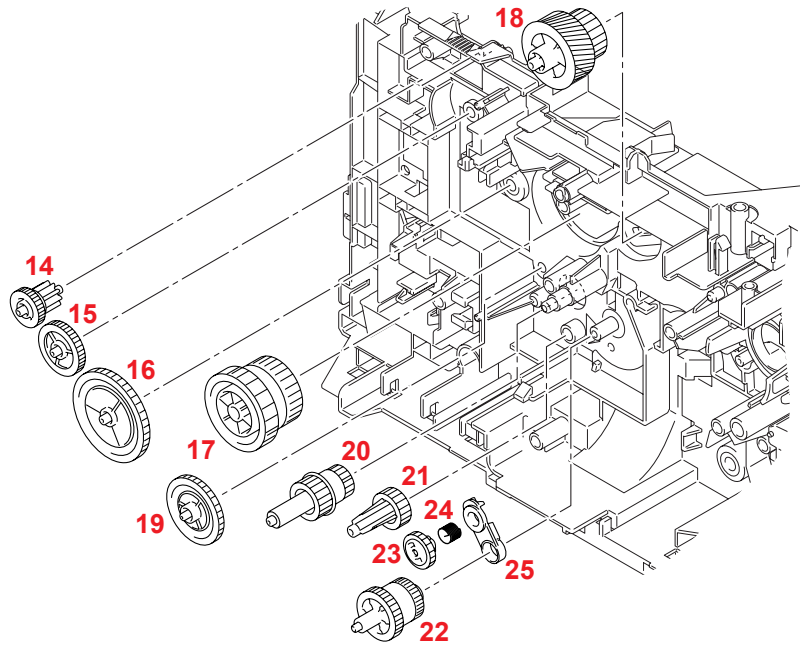


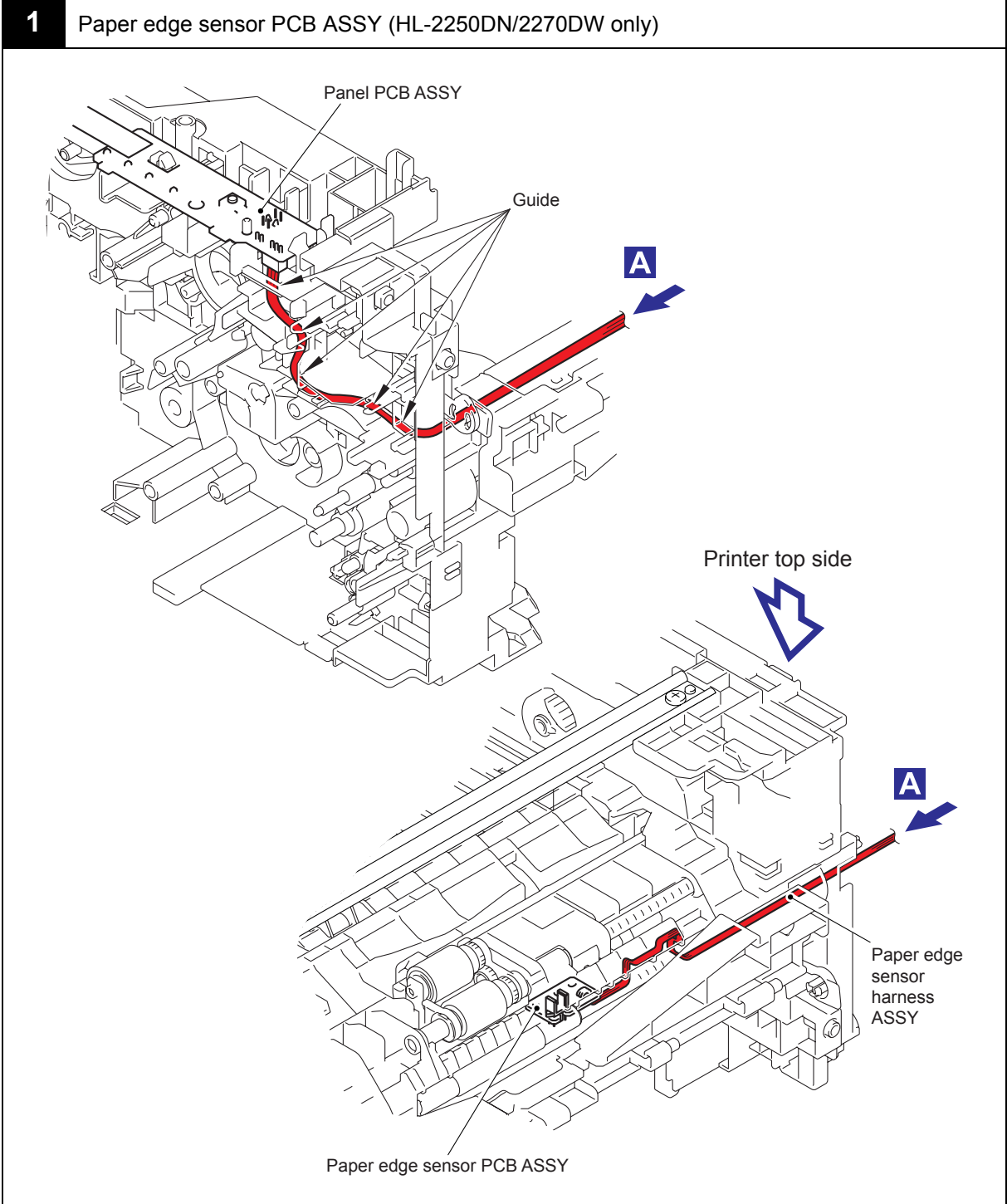
Fig. 3-9

<Name of gears>

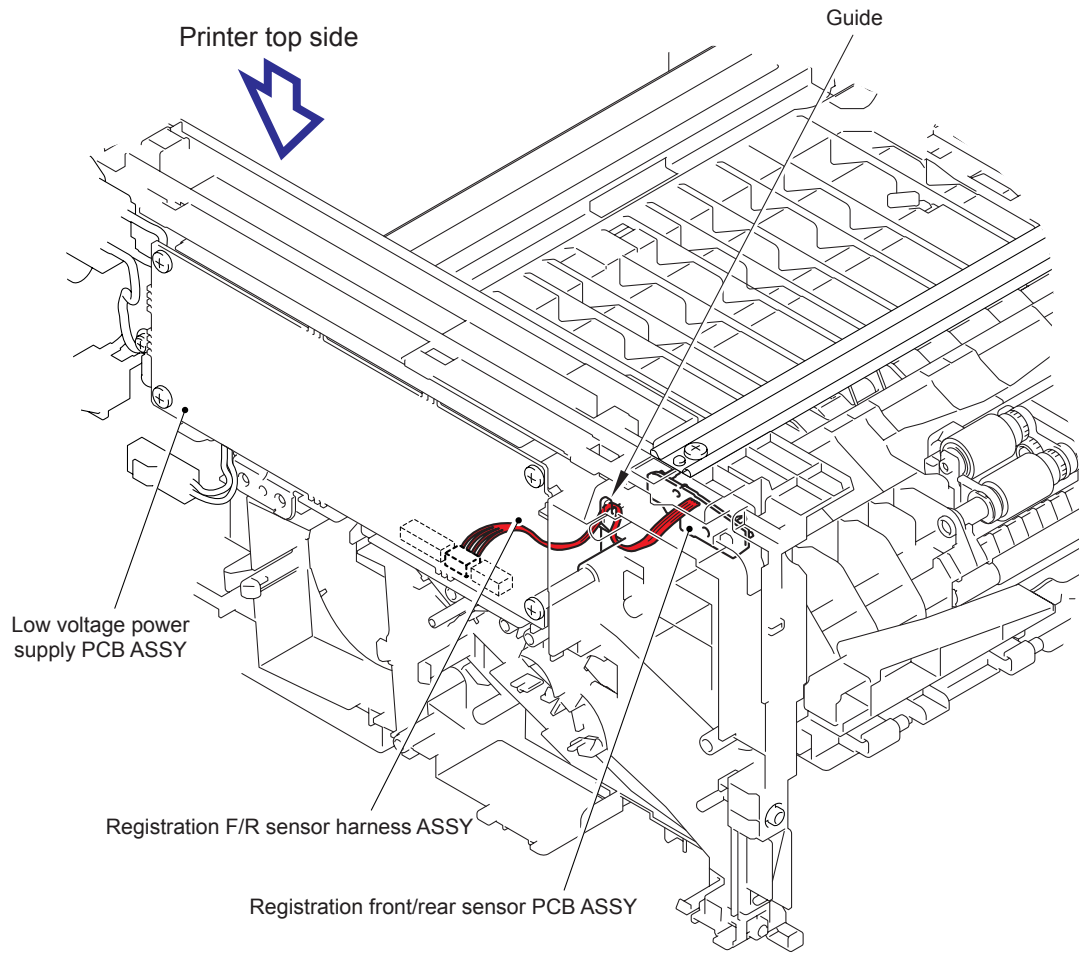
14	LY2011	Ejector gear 10/15	20	LY2015	DX gear 16/20
15	LY2012	Ejector gear 22	21	LY2016	DX gear 19
16	LY2013	Ejector gear 40	22	LY2454	DX gear 21M1/21M0.8
17	LY2010	Fuser gear 28/34	23	LY2038	DX gear 18 pendulum
18	LY2066	Fuser gear 20/54R pendulum	24	LY2037	DX pendulum gear spring
19	LY2014	Ejector gear 29	25	LY2036	DX pendulum holder

\* These parts are subject to change without prior notice

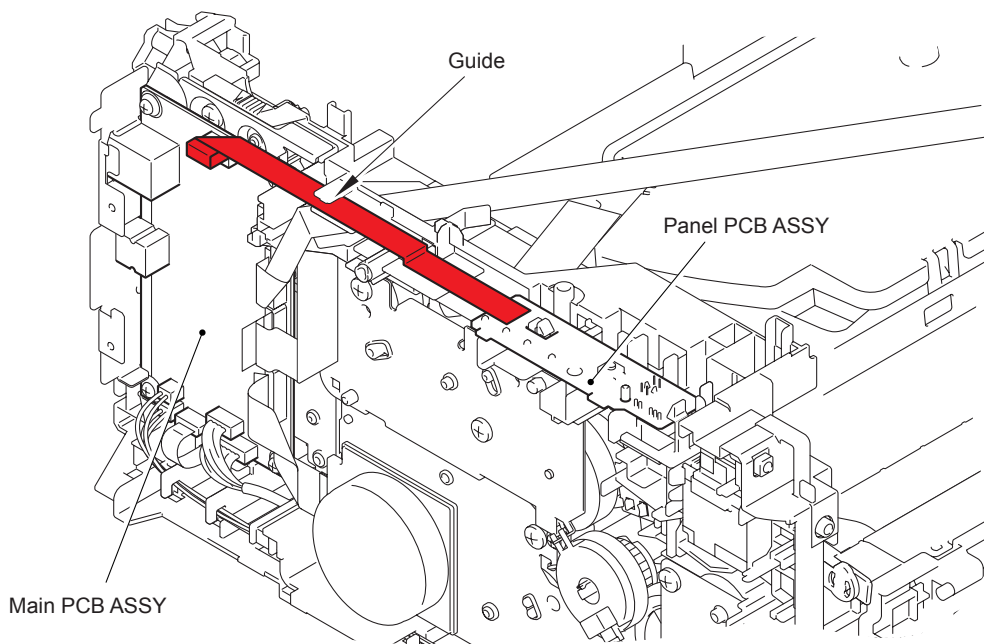
# 7. HARNESS ROUTING



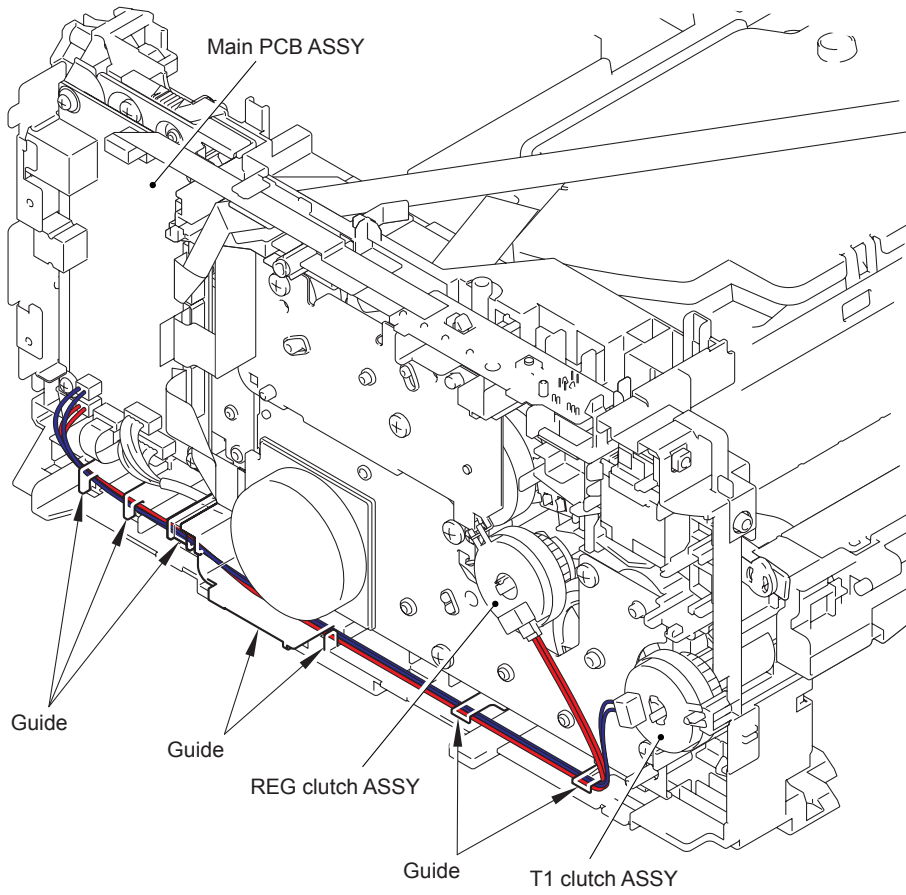
## 2 Registration front/rear sensor PCB ASSY



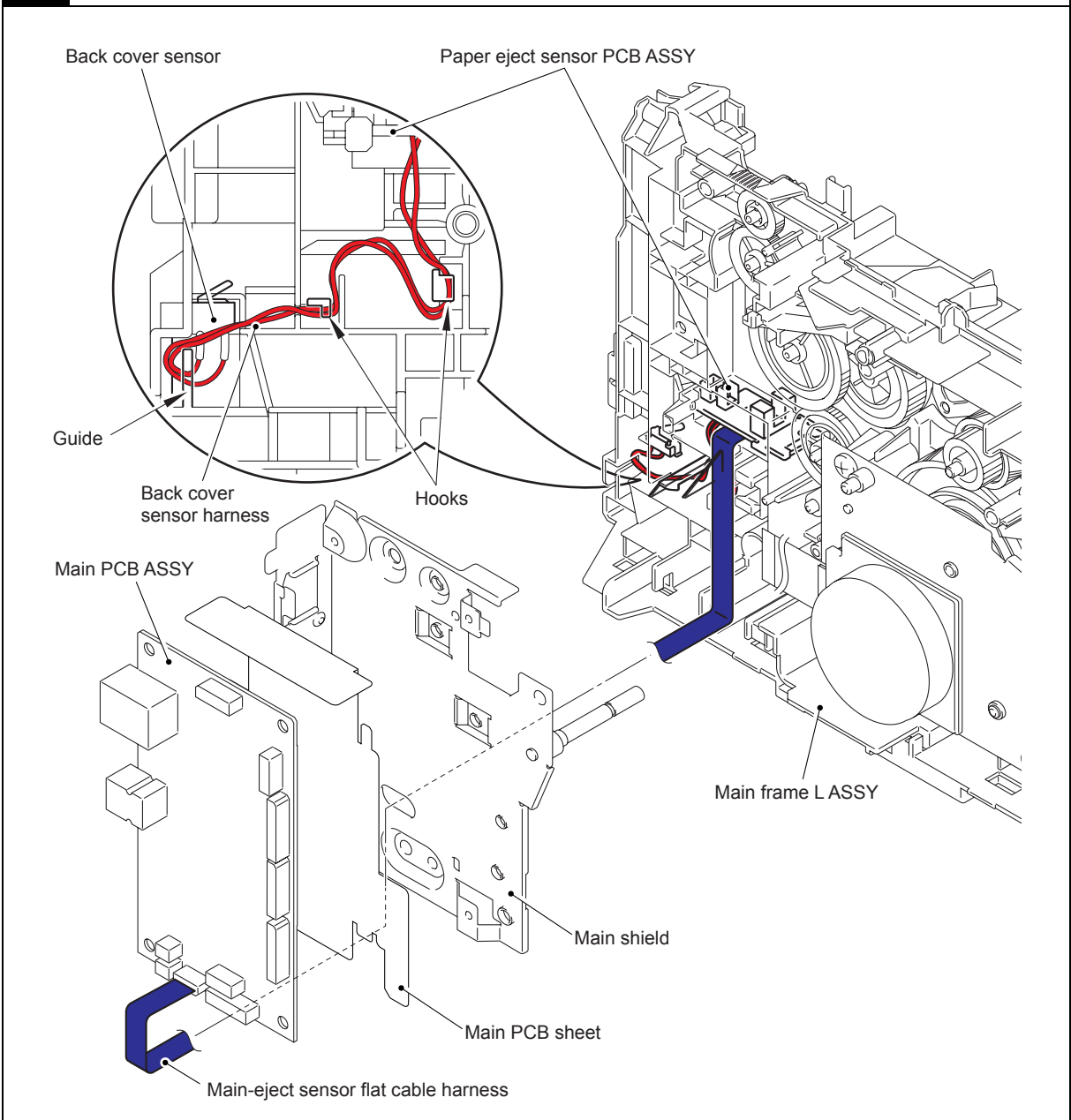
## 3 Panel PCB ASSY



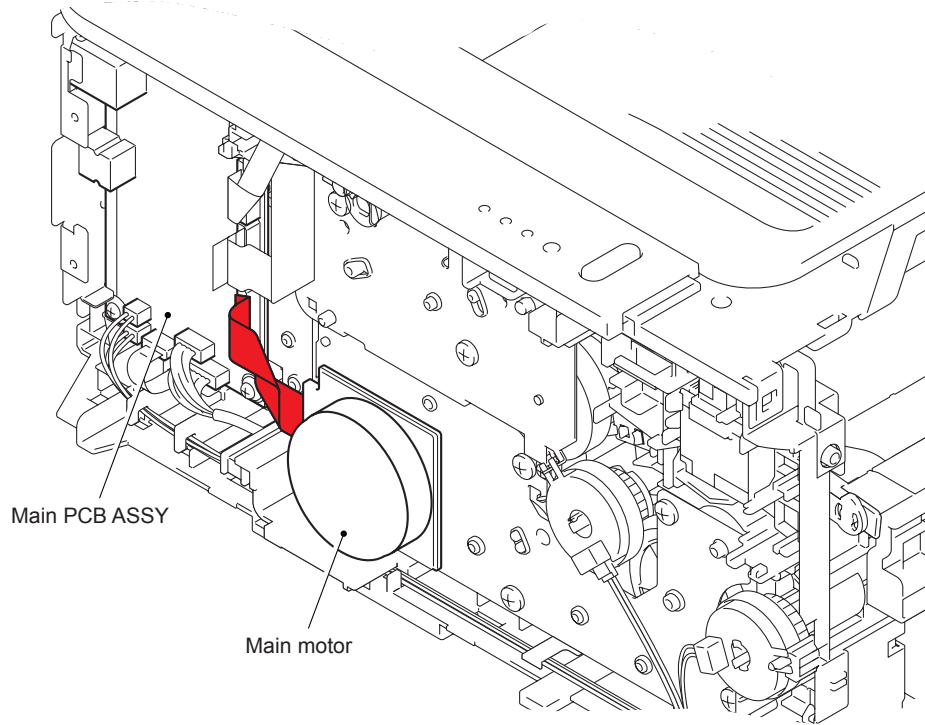
**4** T1 Clutch ASSY, REG Clutch ASSY



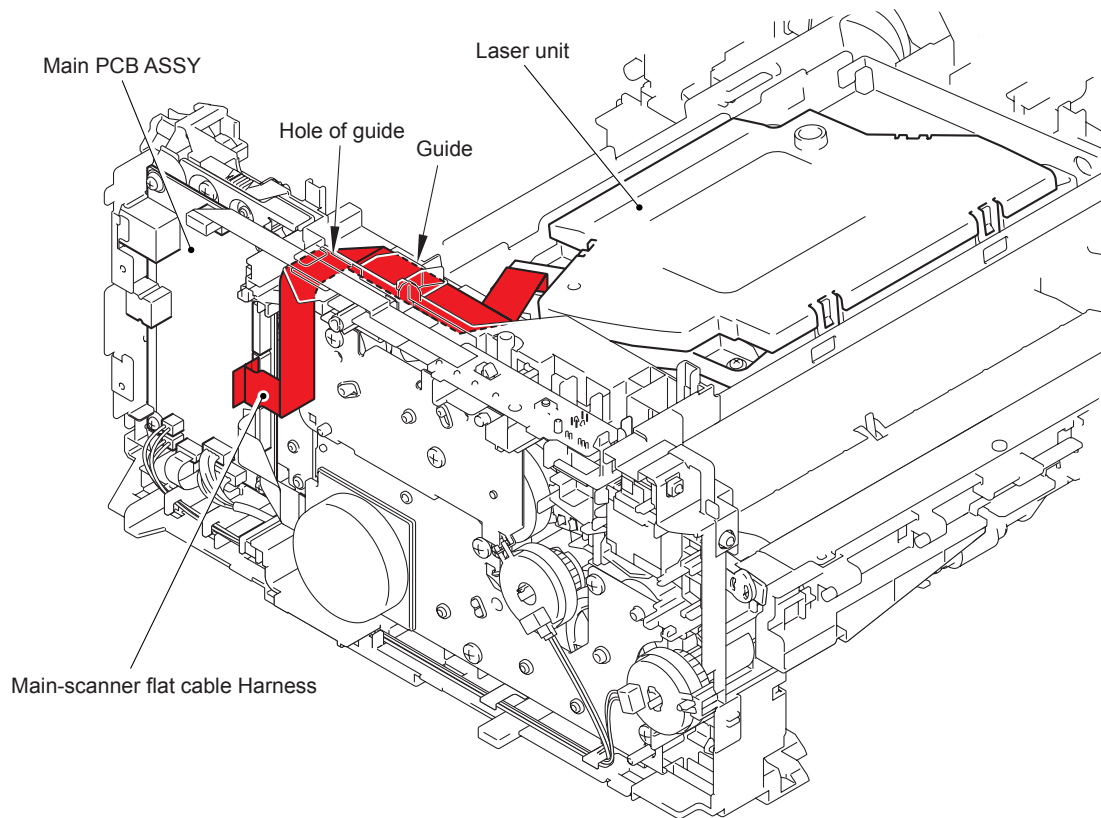
**5** Paper eject sensor PCB ASSY



**6** Main Motor

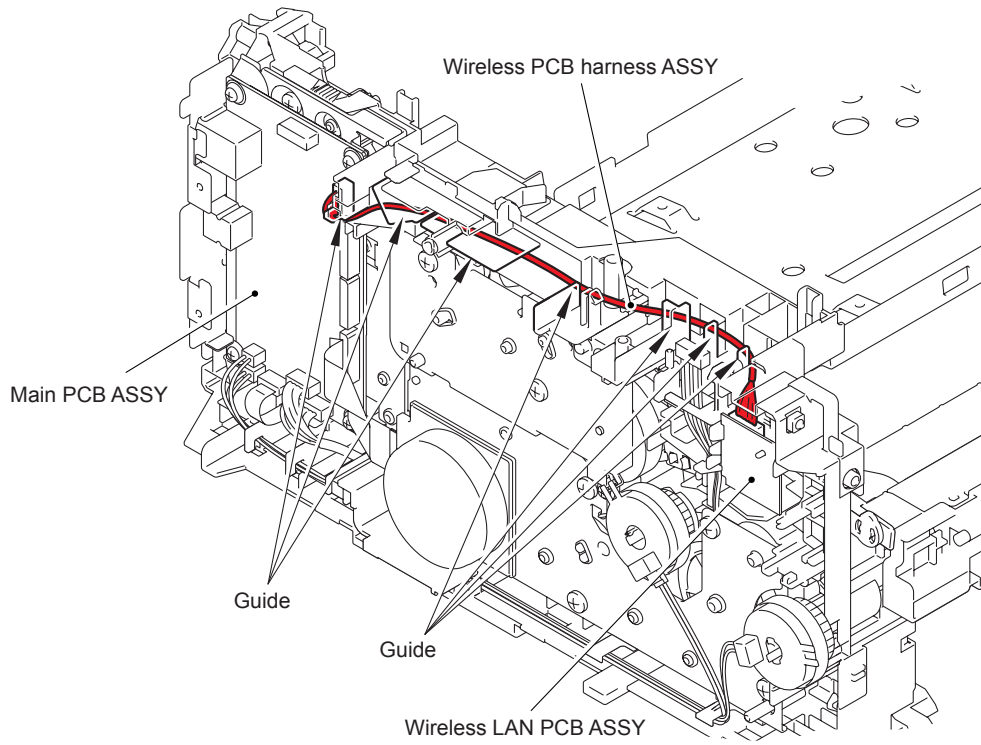


**7** Laser Unit



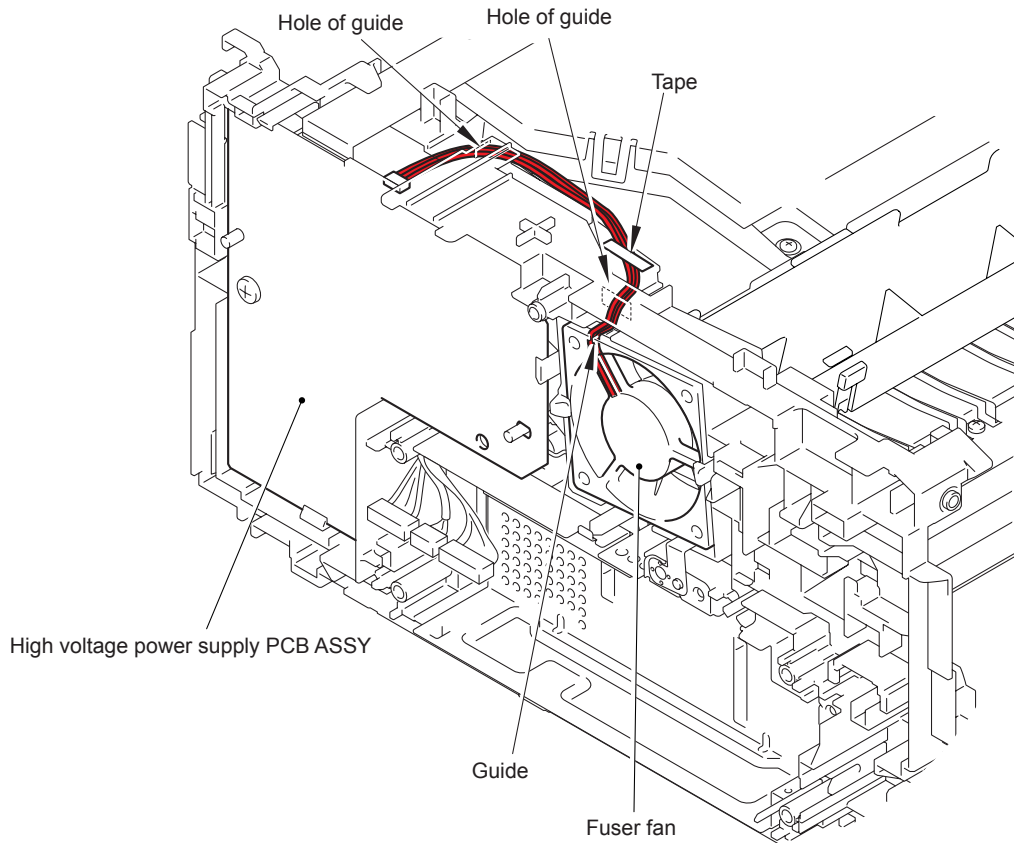
8

Wireless LAN PCB ASSY (Wireless network model only)

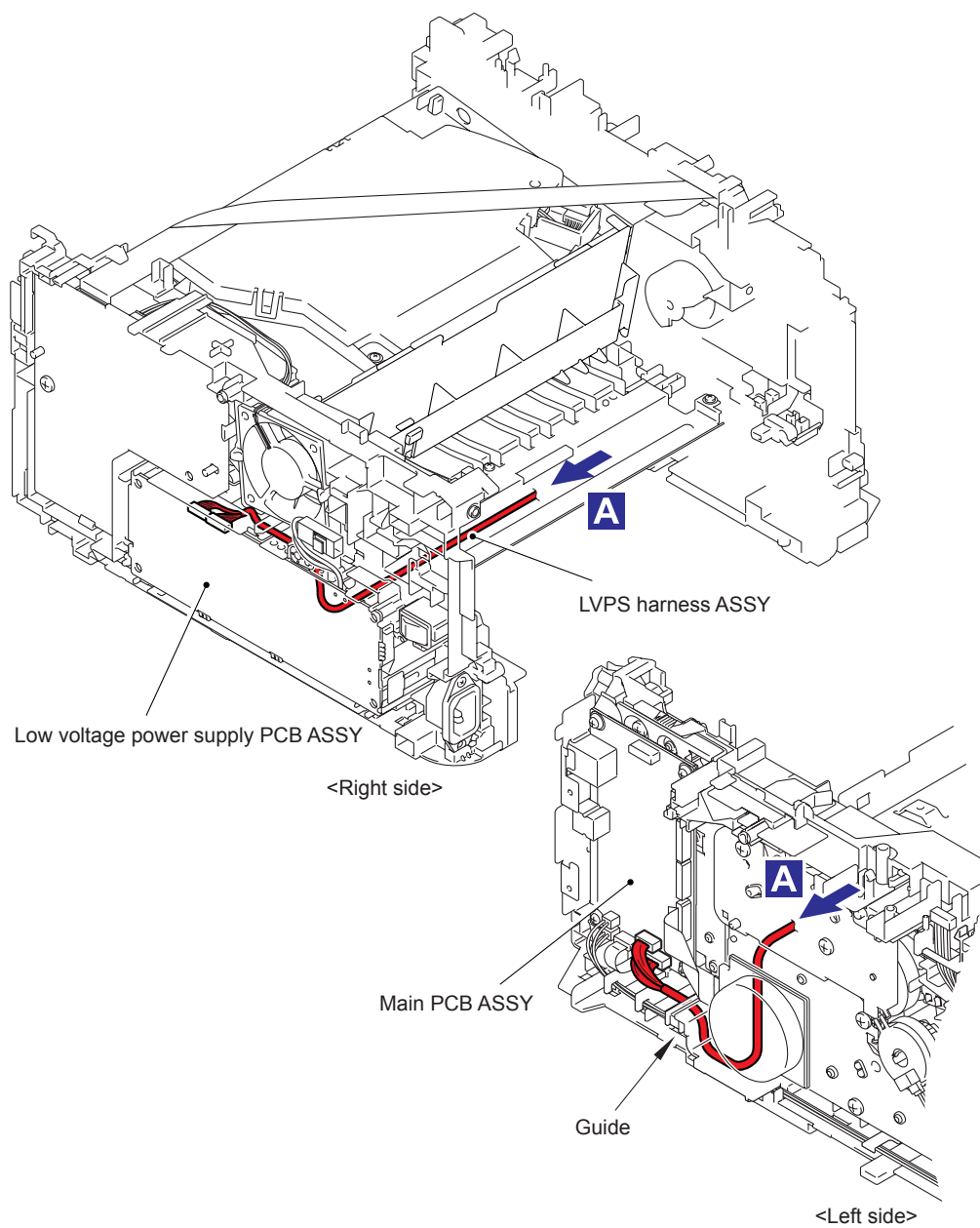


9

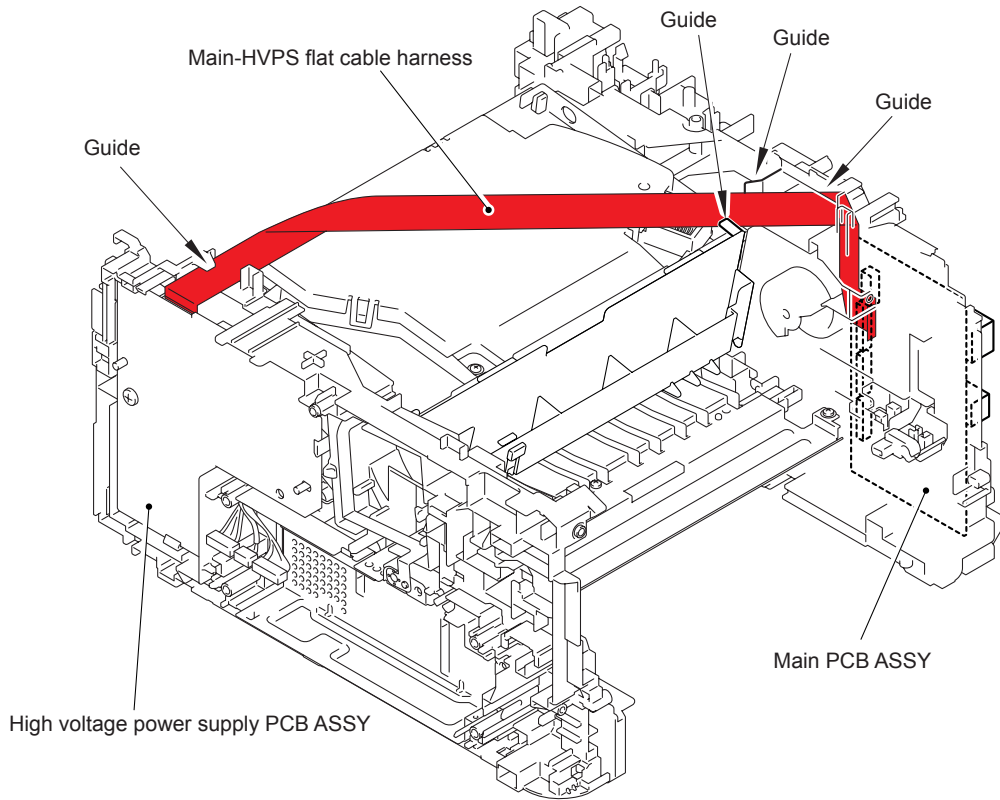
Fuser fan



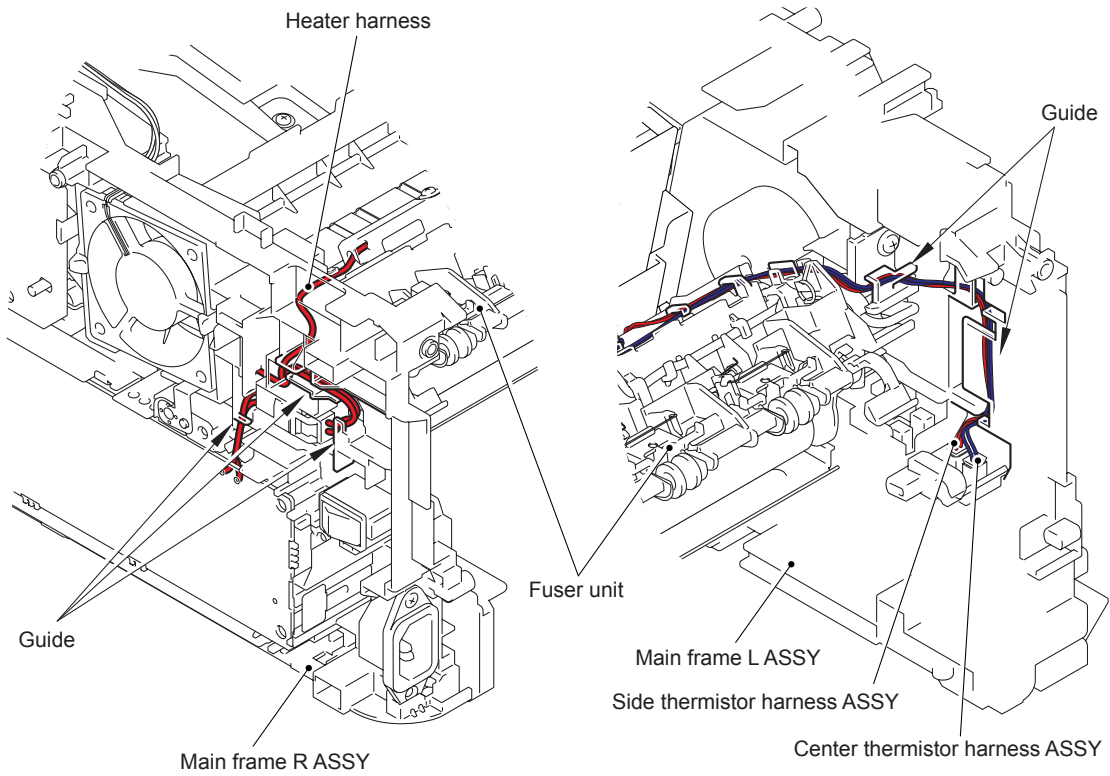
**10** Low voltage power supply PCB ASSY



**11** High voltage power supply PCB ASSY



**12** Fuser Unit



## 8. DISASSEMBLY FLOW

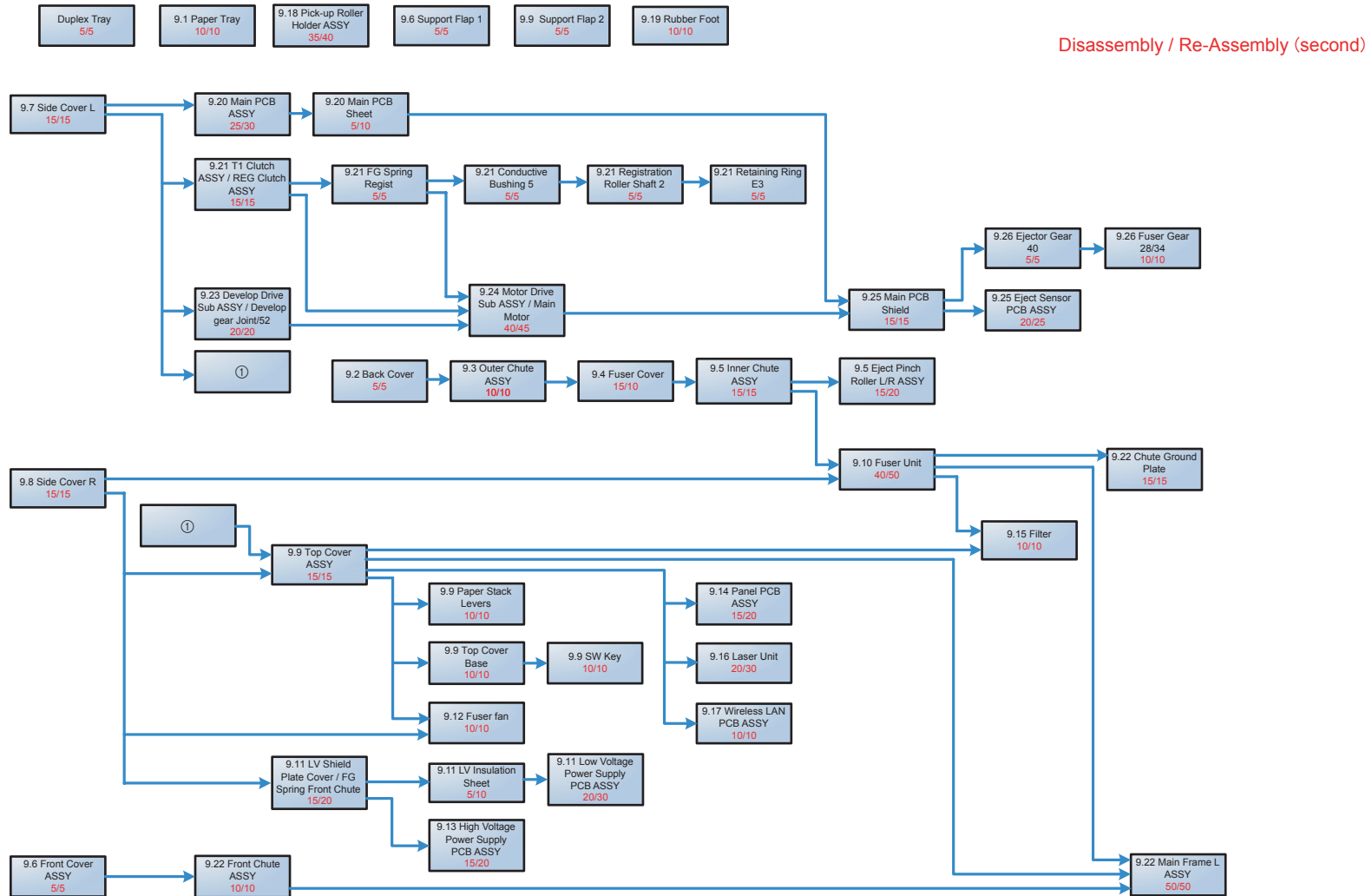


Fig. 3-10

## 9. DISASSEMBLY PROCEDURE

### ■ Preparation

Prior to proceeding with the disassembly procedure,

#### (1) Unplug

- the AC cord,
- the USB cable, if connected,
- the LAN cable, if connected.

#### (2) Remove

- the Paper tray,
- the Toner cartridge and Drum unit,
- the Duplex tray, (HL-2240D/2250DN/2270DW only)
- the LAN port cap. (HL-2250DN/2270DW only)

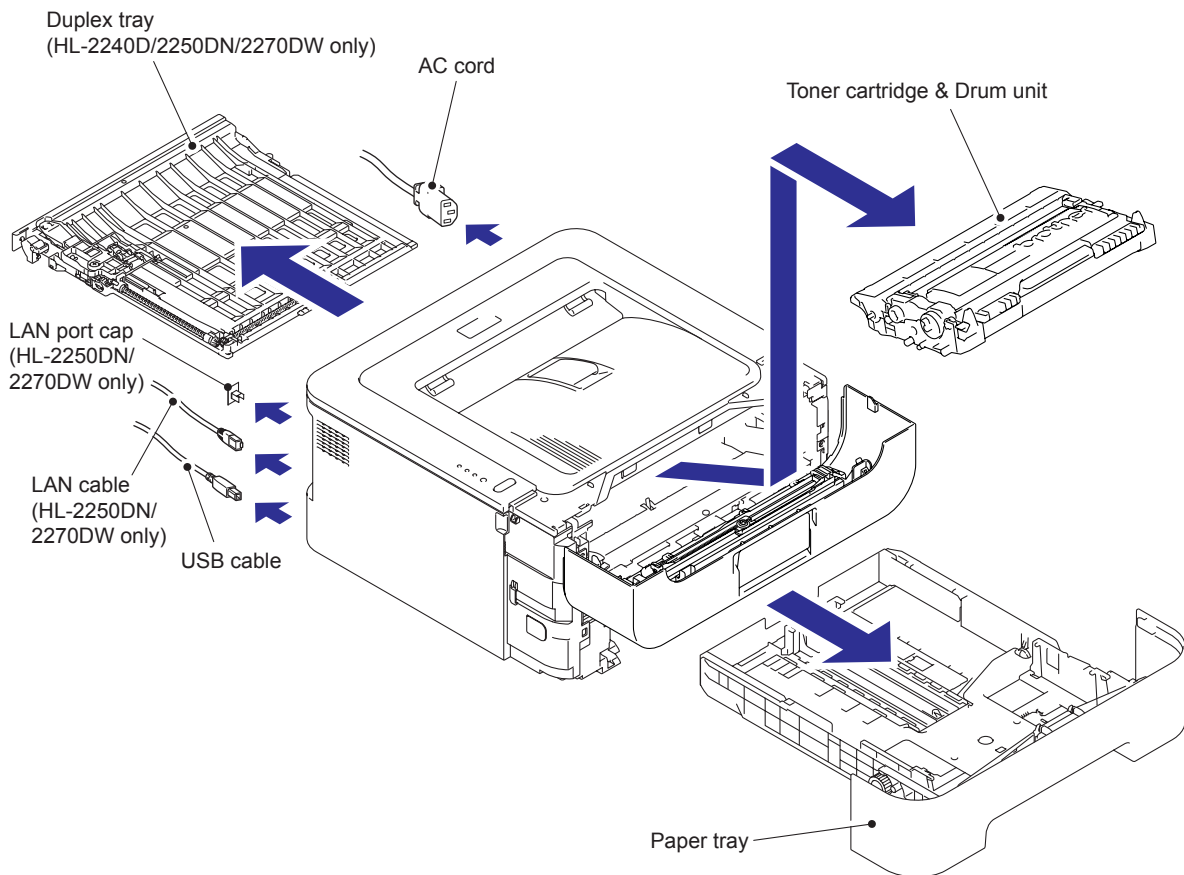
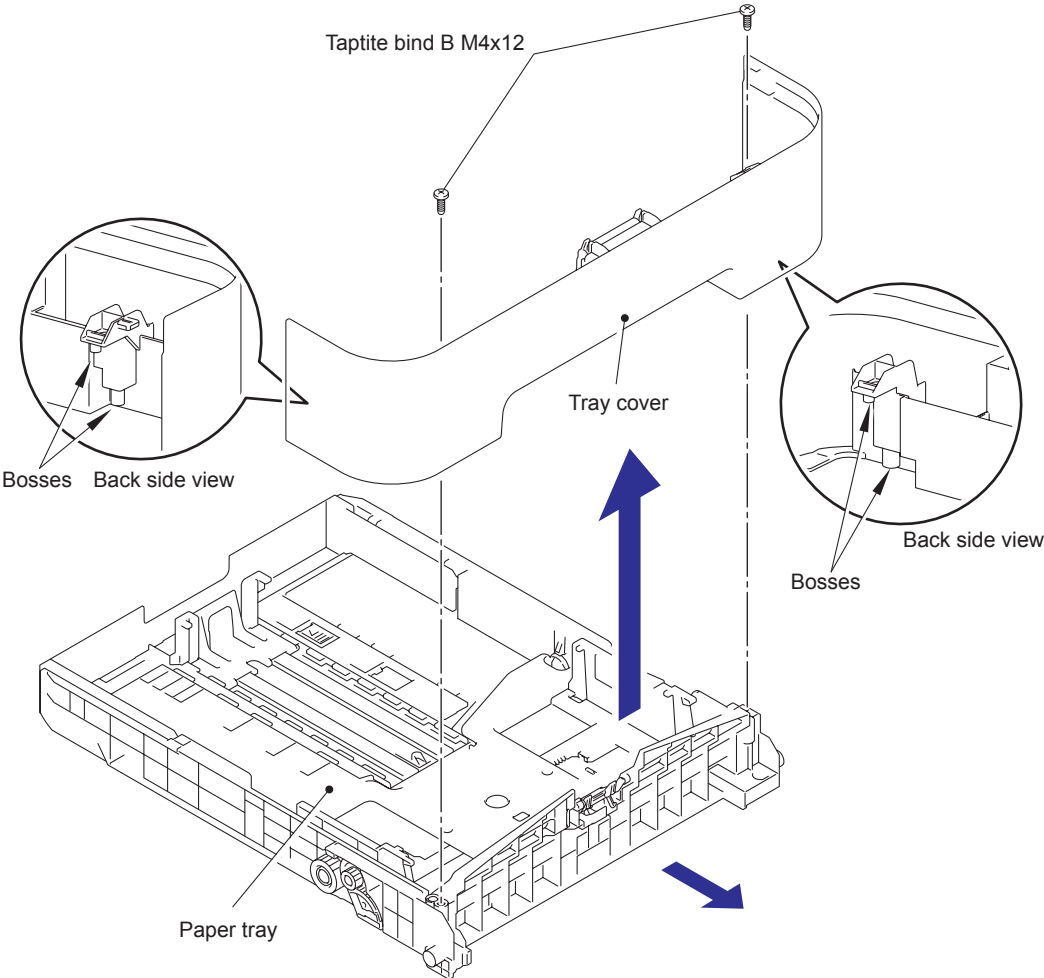


Fig. 3-11

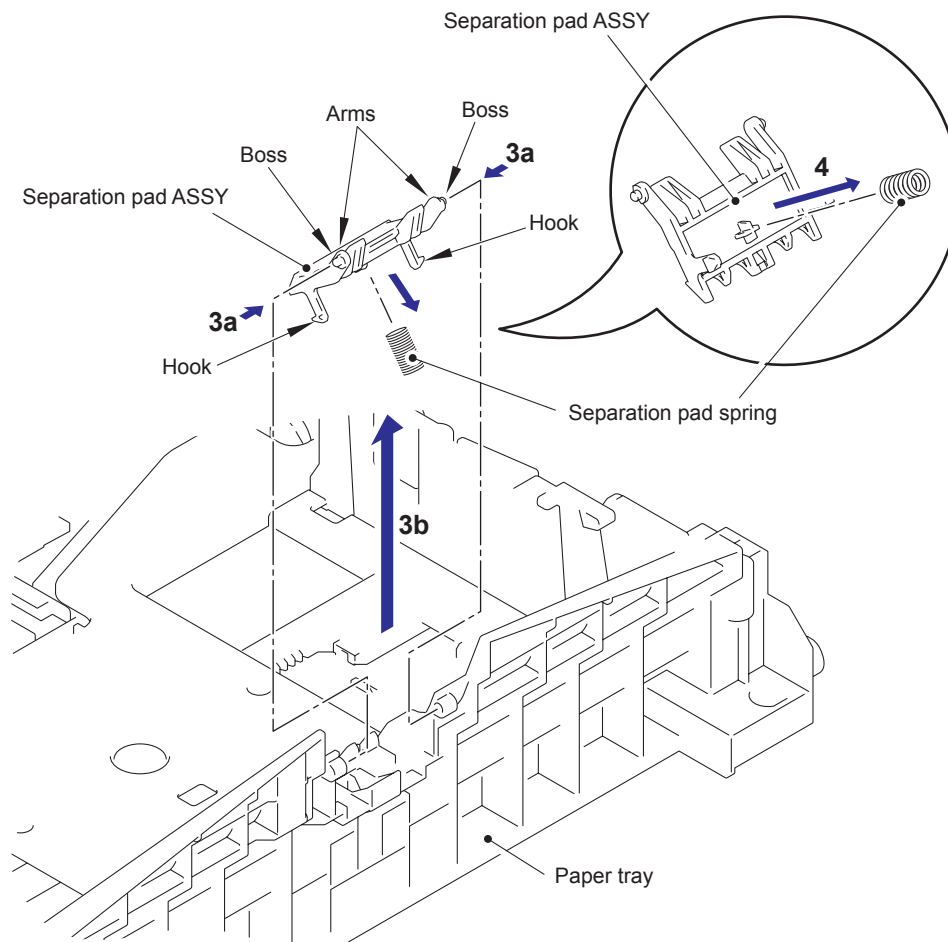
**9.1 Paper Tray**

- (1) Remove the two Taptite bind B M4x12 screws, and release the two Bosses (Upper side), and remove the Tray cover from the Paper tray.



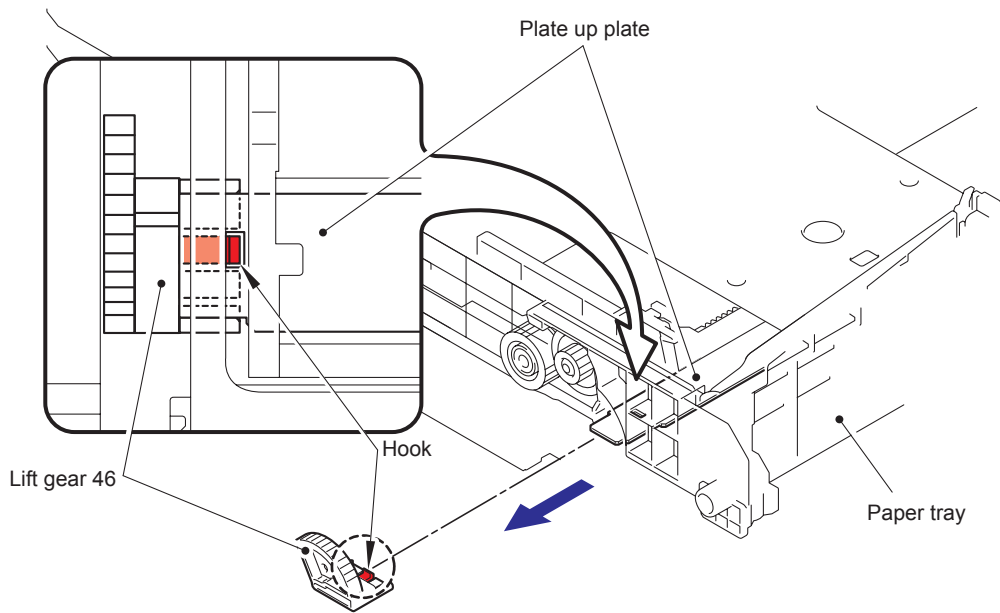
**Fig. 3-12**

- (2) Release the Hooks of the Separation pad ASSY from the Paper tray.
- (3) Press both side Arms of the Separation pad ASSY to remove the Bosses, and remove the Separation pad ASSY from the Paper tray.
- (4) Remove the Separation pad spring from the Separation pad ASSY.



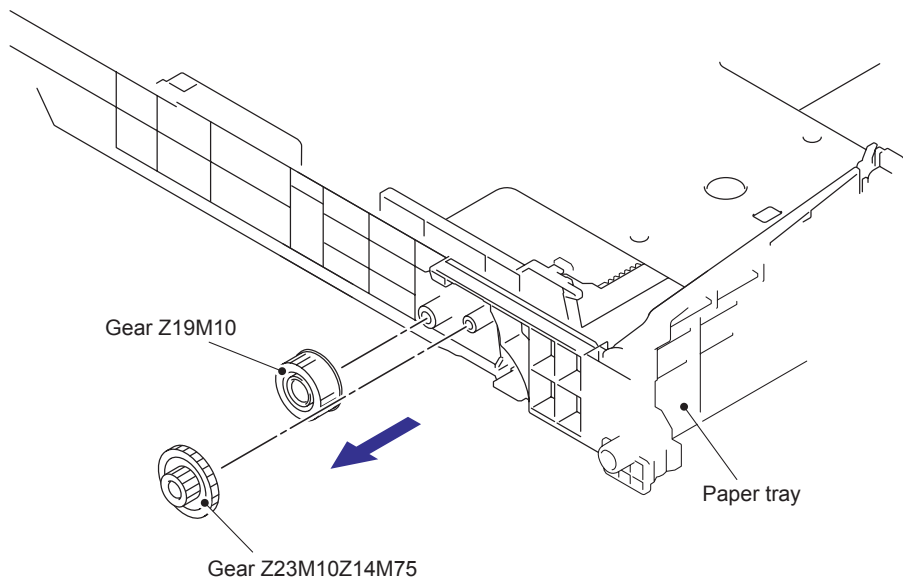
**Fig. 3-13**

- (5) Push the Hook of the Lift gear 46 while pushing up the Plate up plate, and remove the Lift gear 46.



**Fig. 3-14**

- (6) Remove the Gear Z23M10Z14M75 and the Gear Z19M10.



**Fig. 3-15**

## 9.2 Back Cover

<With Duplex Tray model>

- (1) Open the Back cover.
- (2) Push the both side Ribs of the Back cover to the direction of the arrow 2, and release the Boss of the Outer chute ASSY.
- (3) Release the Boss of the Main body while pulling the Back cover to the direction of the arrow 3a, and remove the Back cover.

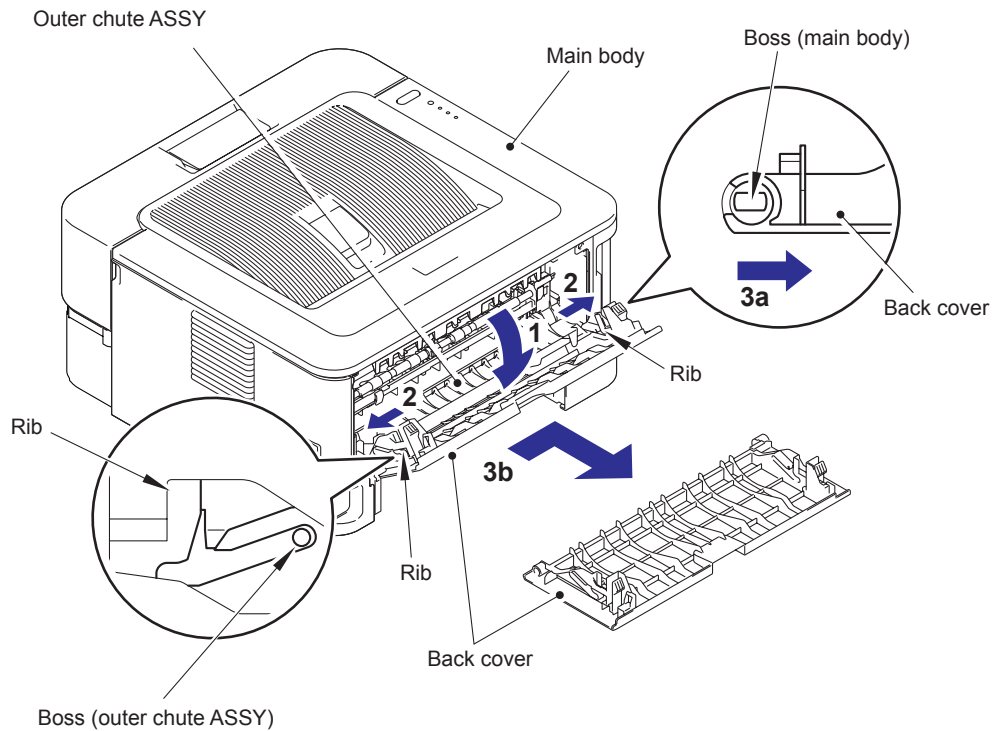


Fig. 3-16

### Assembling Note:

- When assembling the Back cover, close the Back cover with aligning the Boss of the Outer chute ASSY with the groove of both side Ribs of the Back cover.

<Without Duplex Tray model>

- (1) Open the Back cover.
- (2) Push the both side Ribs of the Back cover to the direction of the arrow 2, and release the Boss of the Outer chute ASSY.
- (3) Release the Boss of the Main body while pulling the Back cover to the direction of the arrow 3a, and remove the Back cover.
- (4) Remove the Back cover actuator from the Back cover.

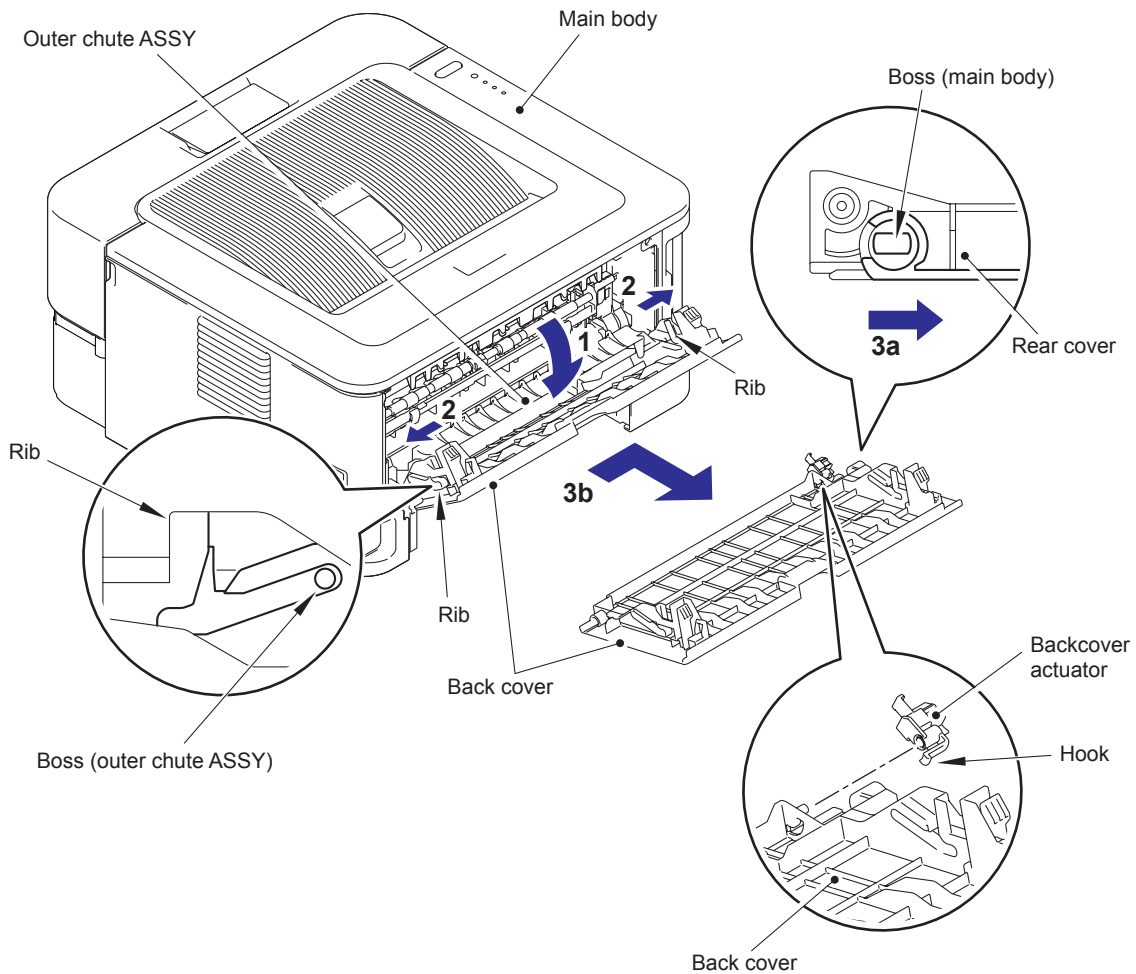


Fig. 3-17

**Assembling Note:**

- When assembling the Back cover, close the Back cover with aligning the Boss of the Outer chute ASSY with the groove of both side Ribs of the Back cover.

### 9.3 Outer Chute ASSY

- (1) Pull the Outer chute ASSY to the direction of the 1a, and release the Boss of the Outer chute ASSY from the Main frame L ASSY, and remove the Outer chute ASSY.

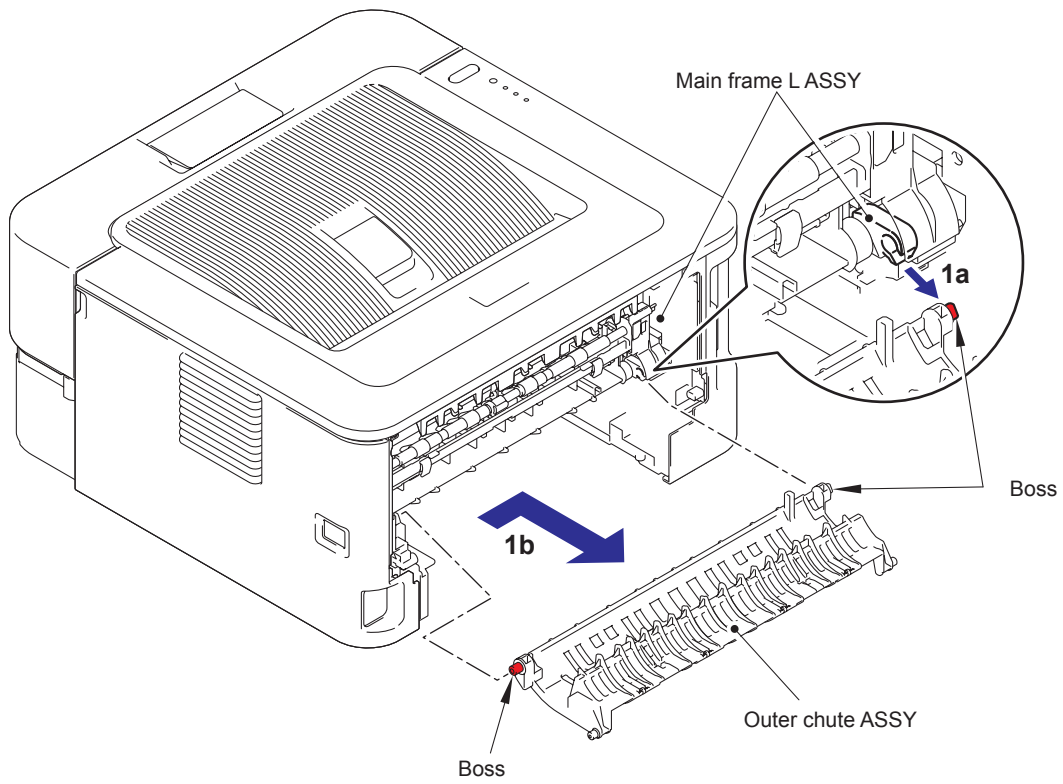


Fig. 3-18

## 9.4 Fuser Cover

- (1) Hold the Knobs on the Fuser cover, and pull down this to your side.
- (2) Release the boss of the main body while pulling the Fuser cover to the direction of the arrow 2a, and remove Fuser cover.

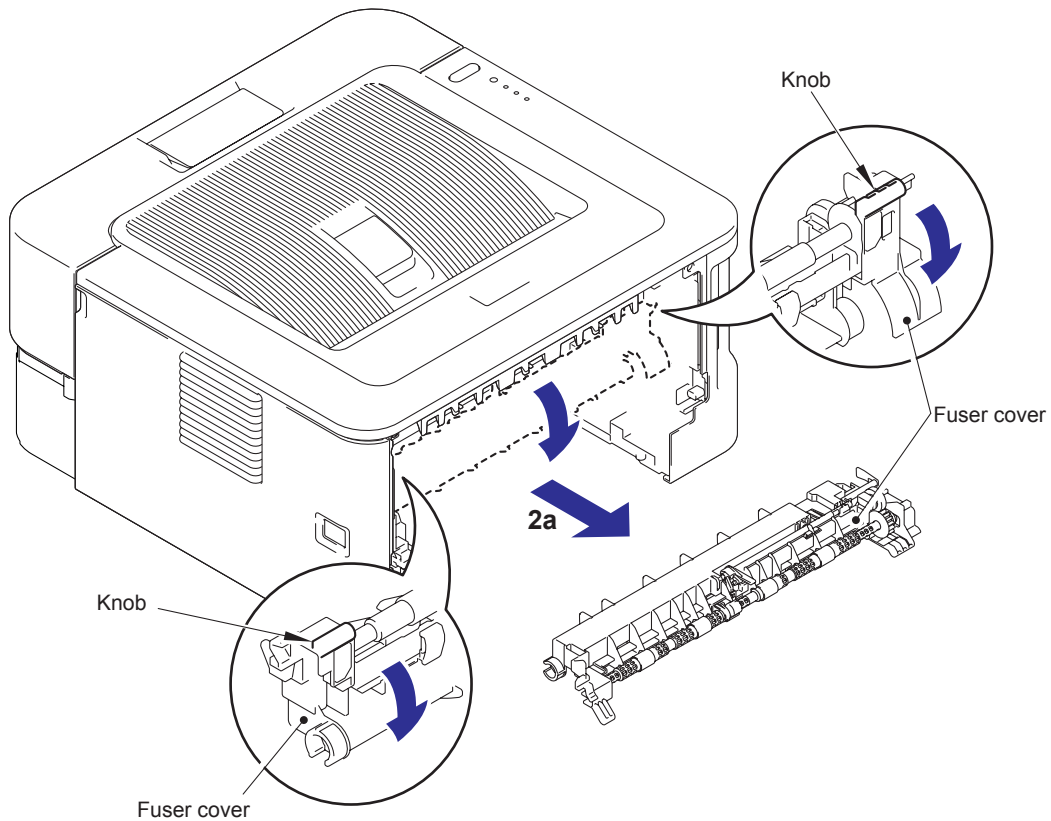


Fig. 3-19

### Assembling Note:

- When assembling the Fuser cover, Check that only one of roller does not lift up. (Check the position of the Anti-curl levers. Refer to [Fig. 2-7](#) in Chapter 2.)

## 9.5 Inner Chute ASSY, Eject Pinch Roller R ASSY and Eject Pinch Roller L ASSY

- (1) Pull down both side Green envelope levers of the Fuser unit.
- (2) Remove the two Taptite bind B M4x12 screws to remove the Inner chute ASSY.

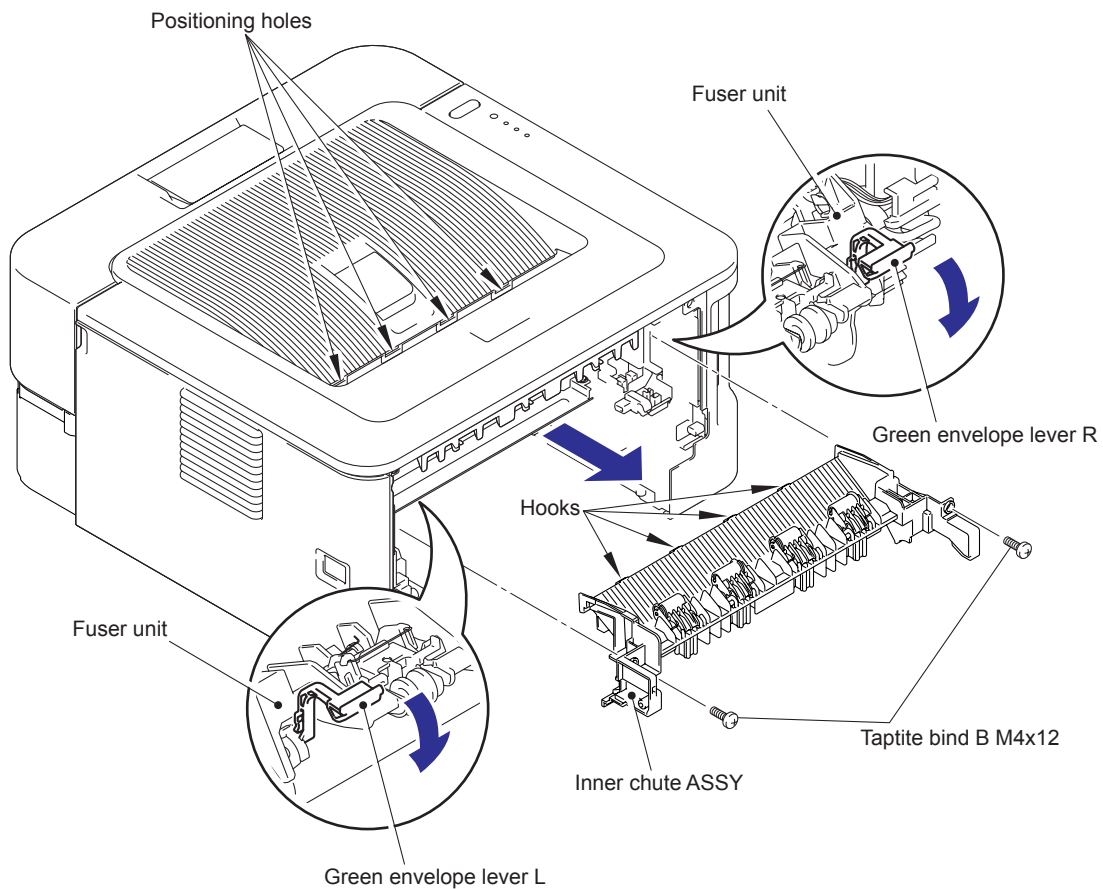
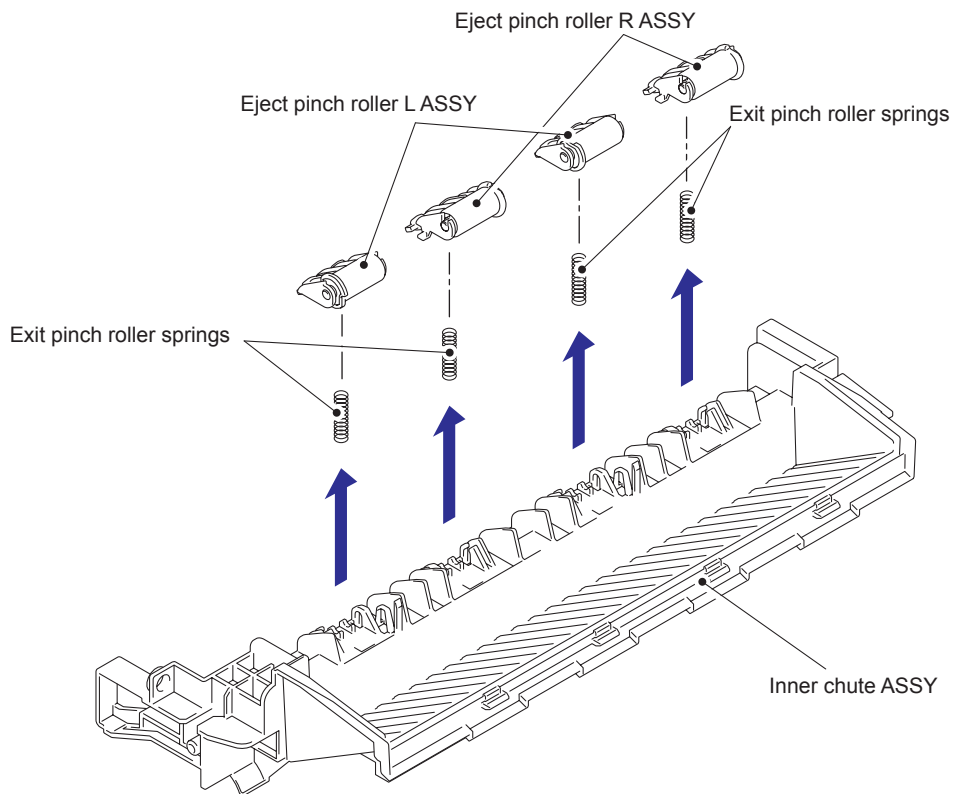


Fig. 3-20

### Assembling Note:

- When assembling the Inner chute ASSY, align the Hooks of the Inner chute ASSY with the Positioning holes of the Top cover ASSY.
- Pull up both side Green levers of the Fuser unit after assembling the Inner chute ASSY.

- (3) Remove the two Eject pinch roller L ASSY and the two Eject pinch roller R ASSY from the Inner chute ASSY.
- (4) Remove the four Exit pinch roller springs from the Eject pinch roller L ASSY and the Eject pinch roller R ASSY.



**Fig. 3-21**

## 9.6 Front Cover ASSY, Support Flap 1

- (1) Open the Front cover ASSY.
- (2) Release the Hooks of the Develop joint link to remove the Develop joint link from the Front cover ASSY.
- (3) Pull up the Rib of the Front chute ASSY to the direction of the arrow 3a, and slid the Front cover ASSY to the direction of the arrow 3b and 3c, and remove it.

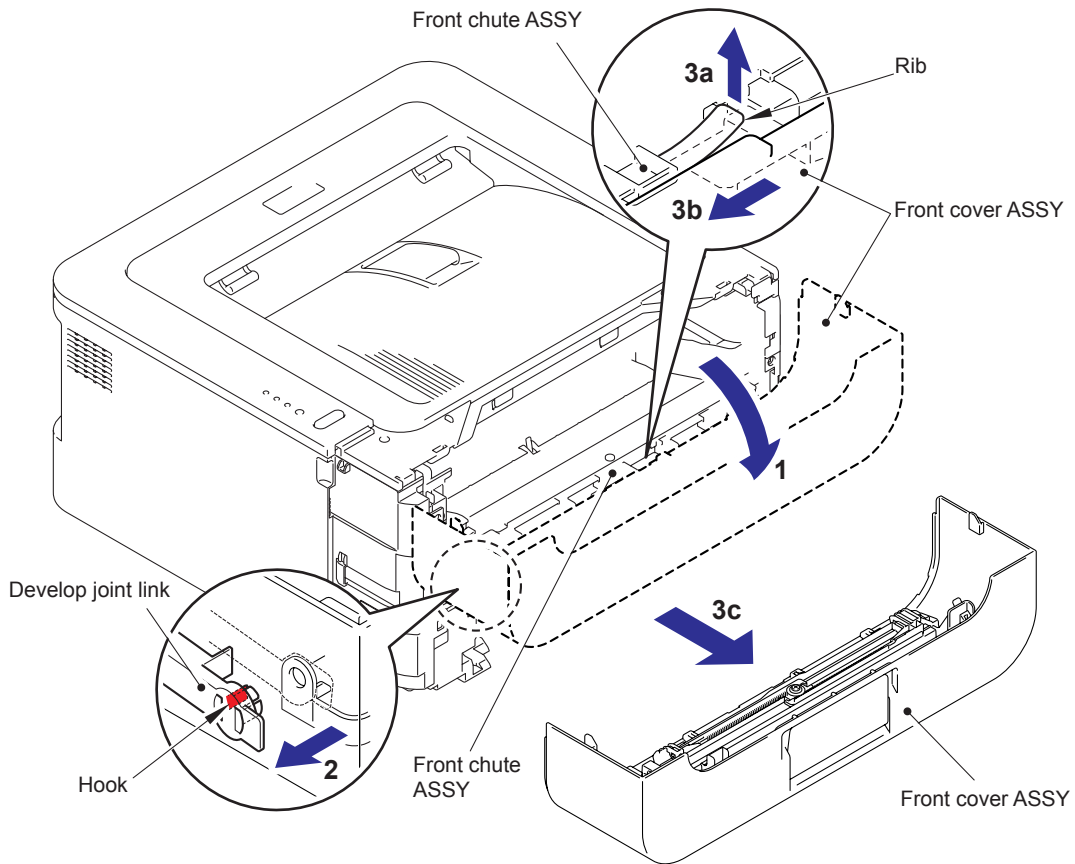


Fig. 3-22

- (4) Remove the Support flap 1 from the Front cover ASSY.

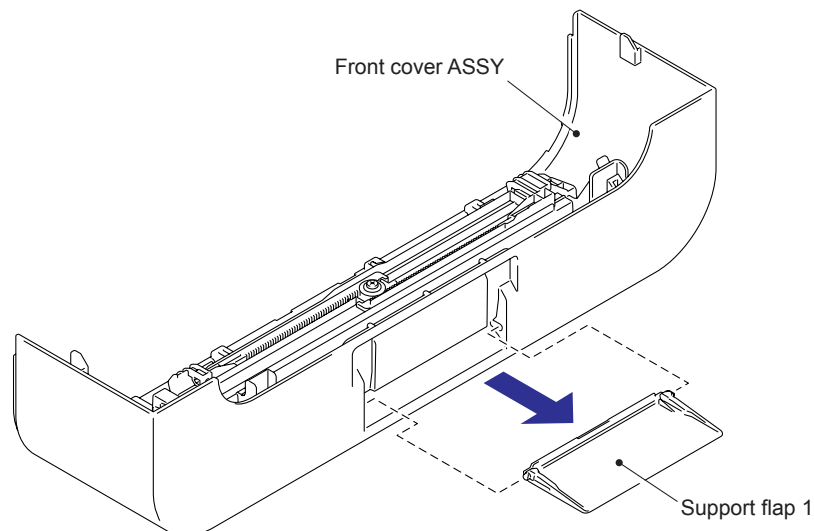
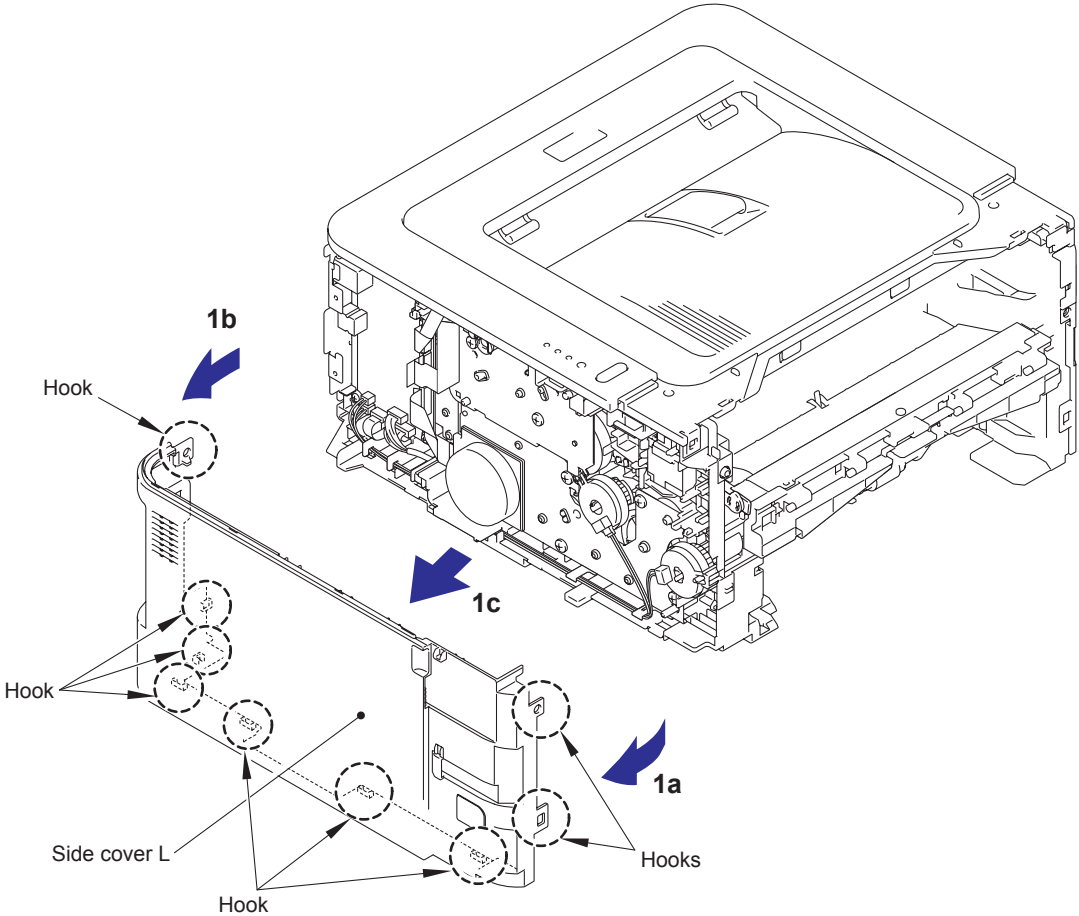


Fig. 3-23

**9.7 Side Cover L**

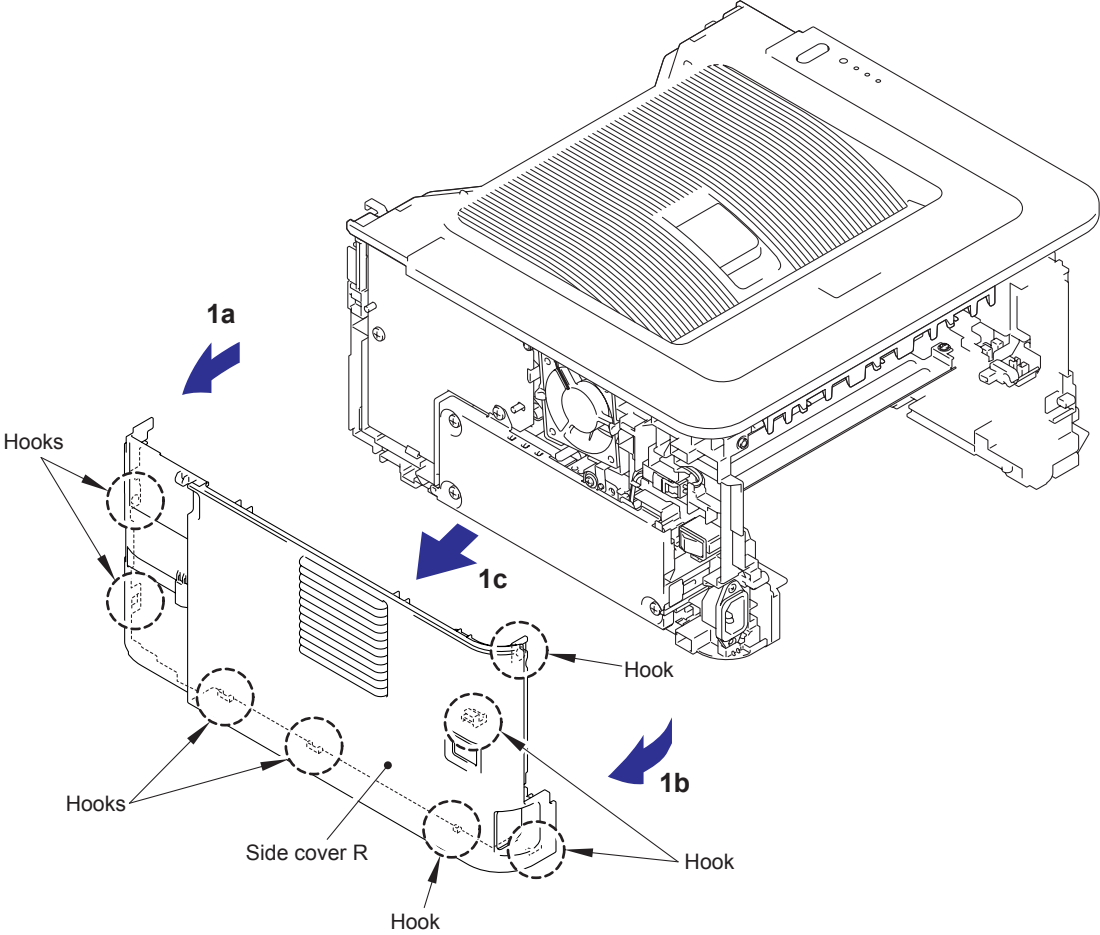
(1) Release the Hooks in the order of 1a, 1b and 1c, and remove the Side cover L.



**Fig. 3-24**

**9.8 Side Cover R**

(1) Release the Hooks in the order of 1a, 1b and 1c, and remove the Side cover R.



**Fig. 3-25**

## 9.9 Top Cover ASSY

- (1) Release the Hooks of the Top cover ASSY from A to F.
- (2) Pull the Top cover ASSY to the direction of the arrow 2a, and remove it from the Main body.

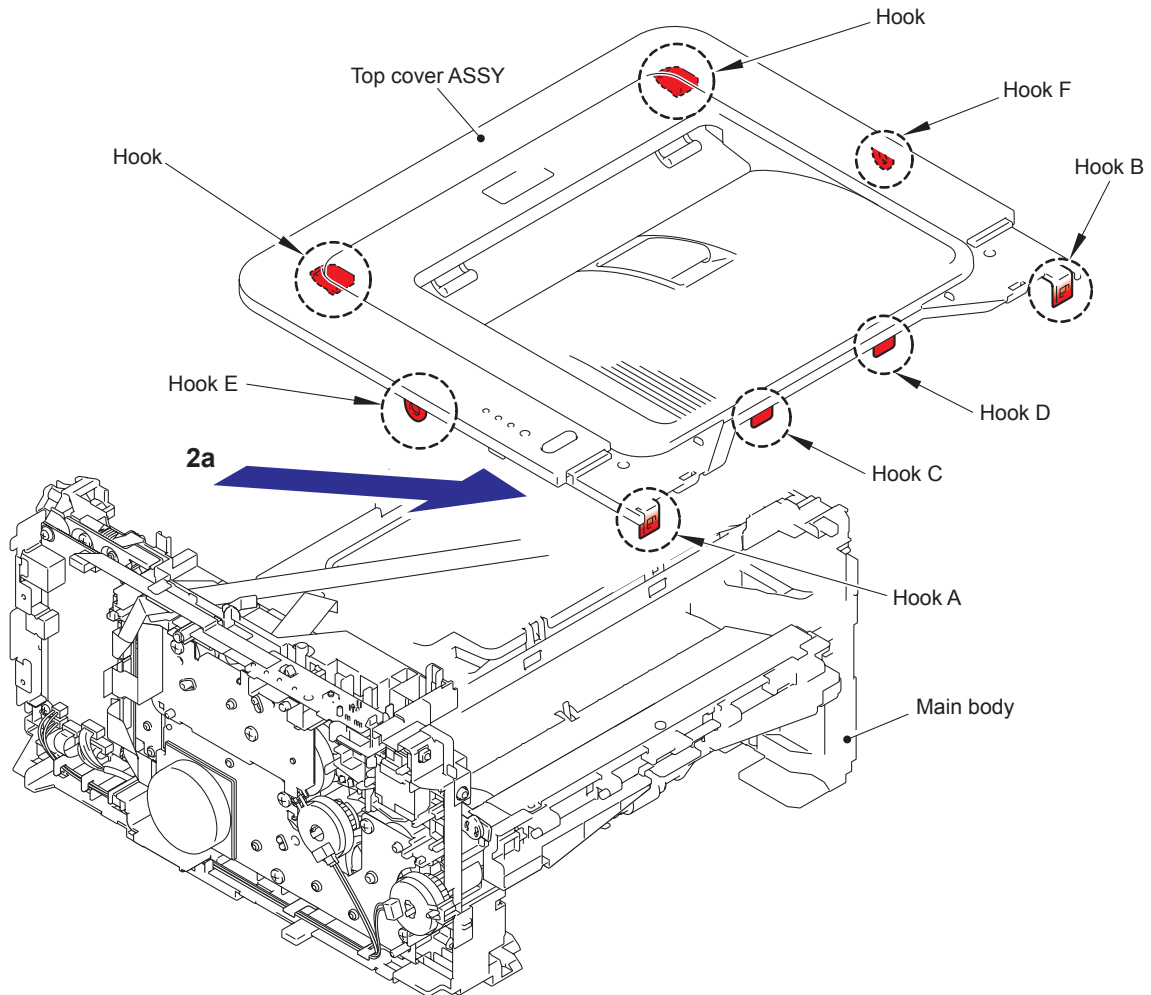
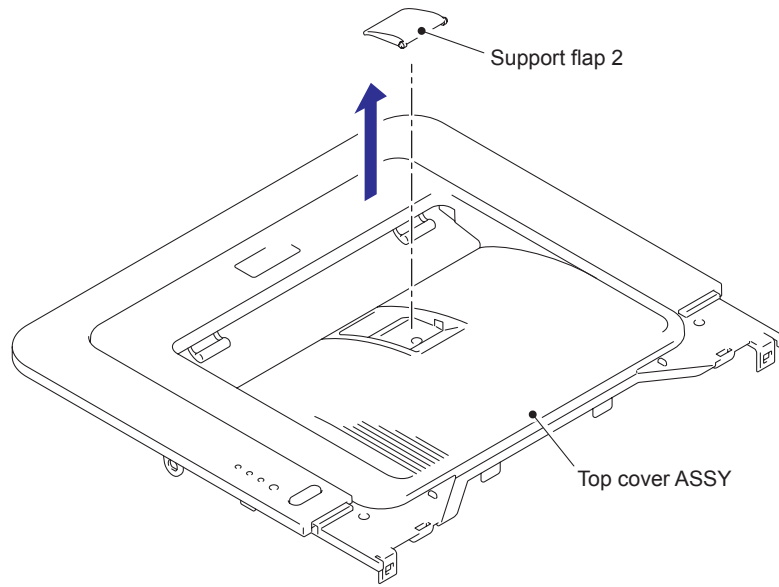


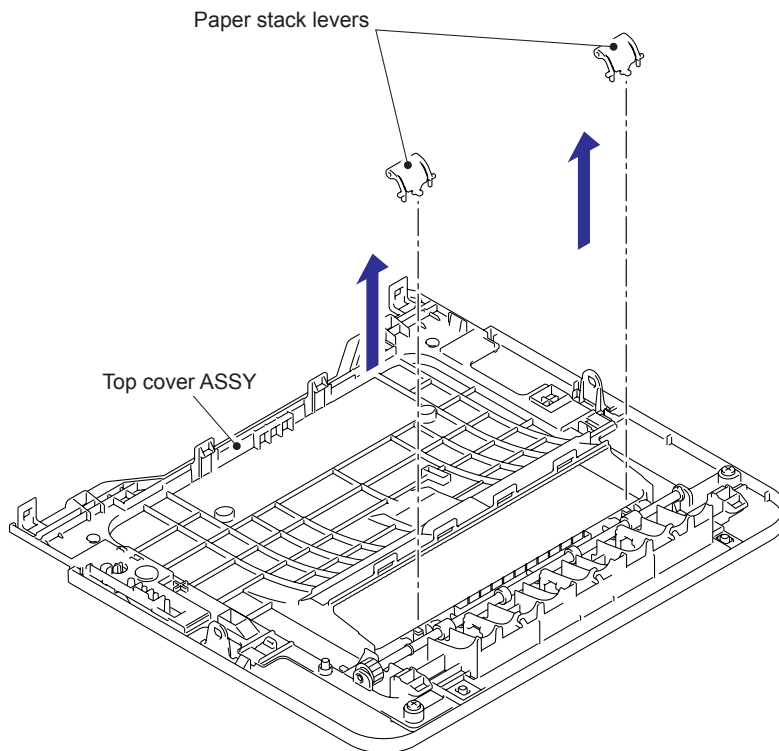
Fig. 3-26

- (3) Remove the Support flap 2 from the Top cover ASSY.



**Fig. 3-27**

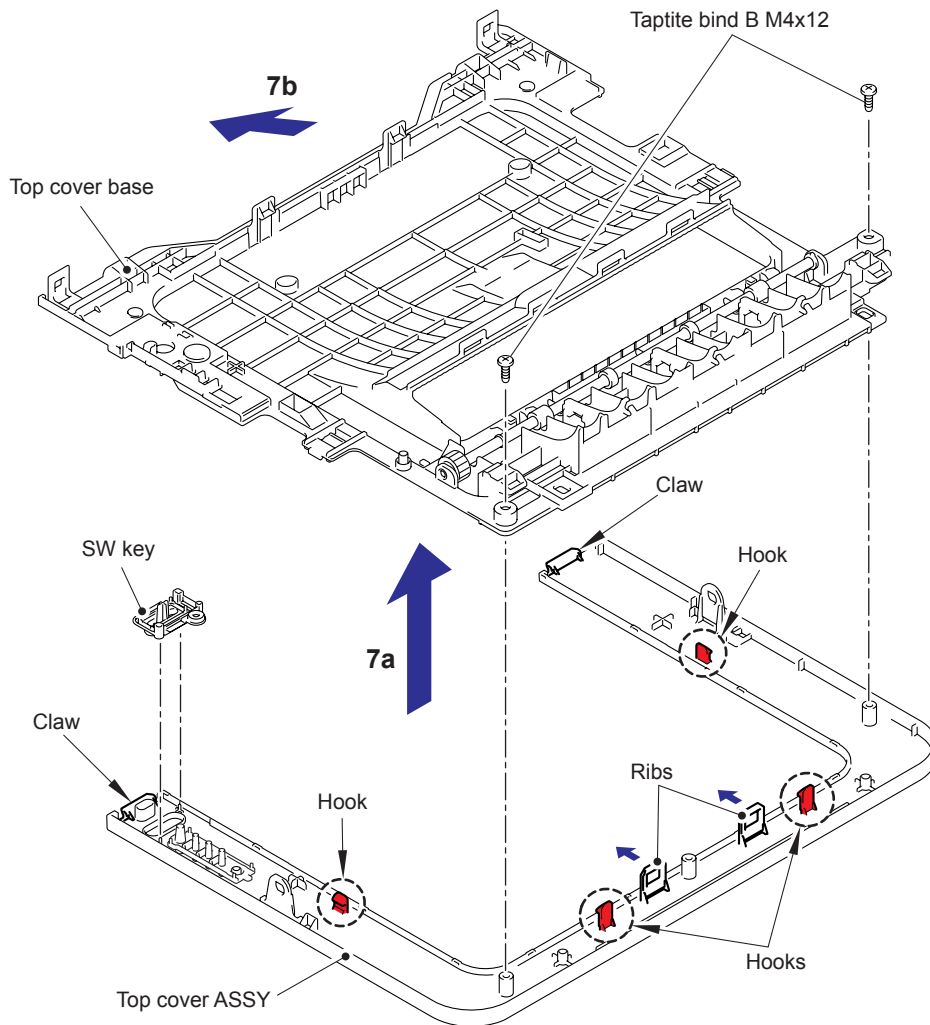
- (4) Turn the Top cover ASSY upside down.  
(5) Remove the two Paper stack levers from the Top cover ASSY.



**Fig. 3-28**

**(Top cover ASSY <except for HL-2130>)**

- (6) Remove the two Taptite bind B M4x12 screws.
- (7) Release the four Hooks and two Ribs of the Top cover ASSY, and remove the Top cover base from the Top cover ASSY.
- (8) Remove the SW key from the Top cover ASSY.



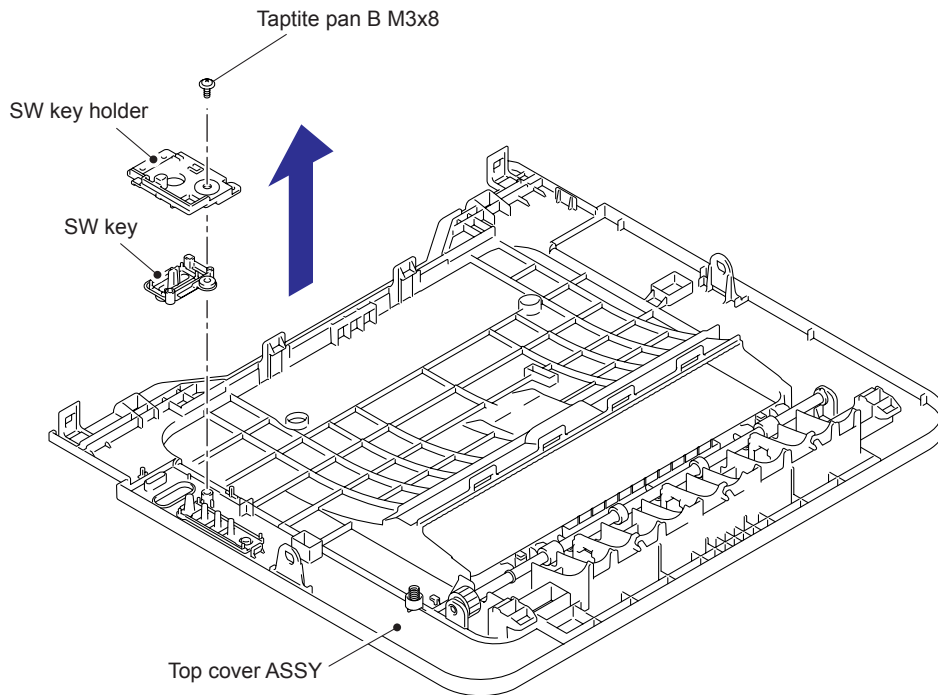
**Fig. 3-29**

**Assembling Note:**

- When assembling the Top cover ASSY and the Top cover base, check that the Claws of the Top cover base is inserted into the positioning holes of the Top cover ASSY.

**(Top cover ASSY <HL-2130>)**

- (6) Remove the Taptite pan B M3x8 screw, and remove the SW key holder and the SW key from the Top cover ASSY.



**Fig. 3-30**

## 9.10 Fuser Unit

- (1) Release the Harness of the Fuser unit from the Guides of the Main frame R ASSY.
- (2) Disconnect the Connector of the Low voltage power supply PCB ASSY while pushing the Hook of the Connector of the Fuser unit.

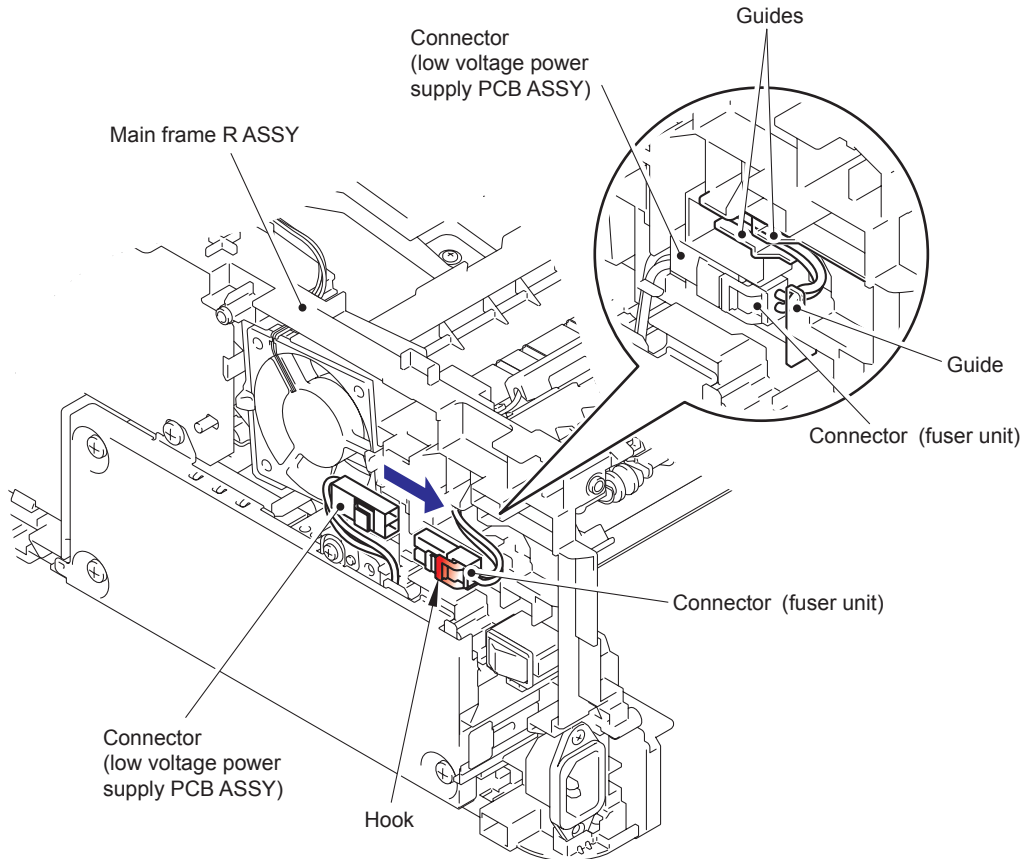


Fig. 3-31

- (3) Put the Connector of the Fuser unit through the Hole of the Main frame R ASSY.

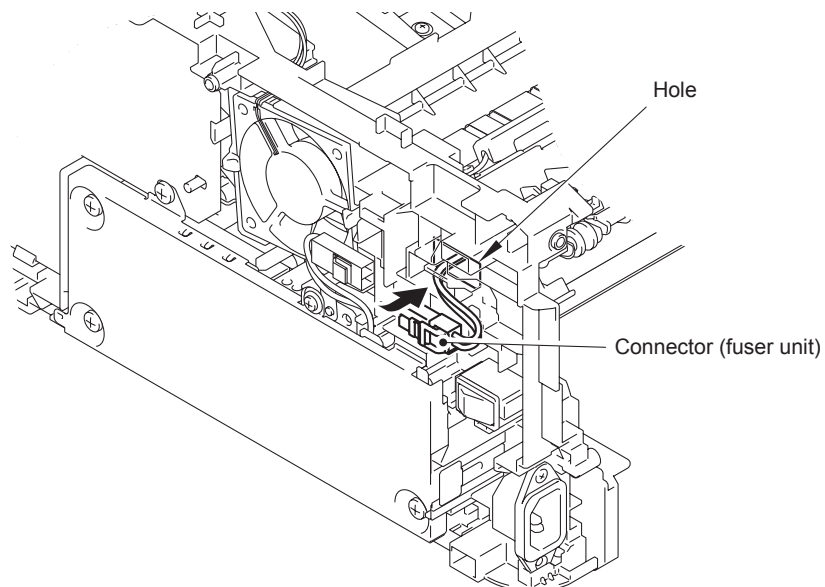
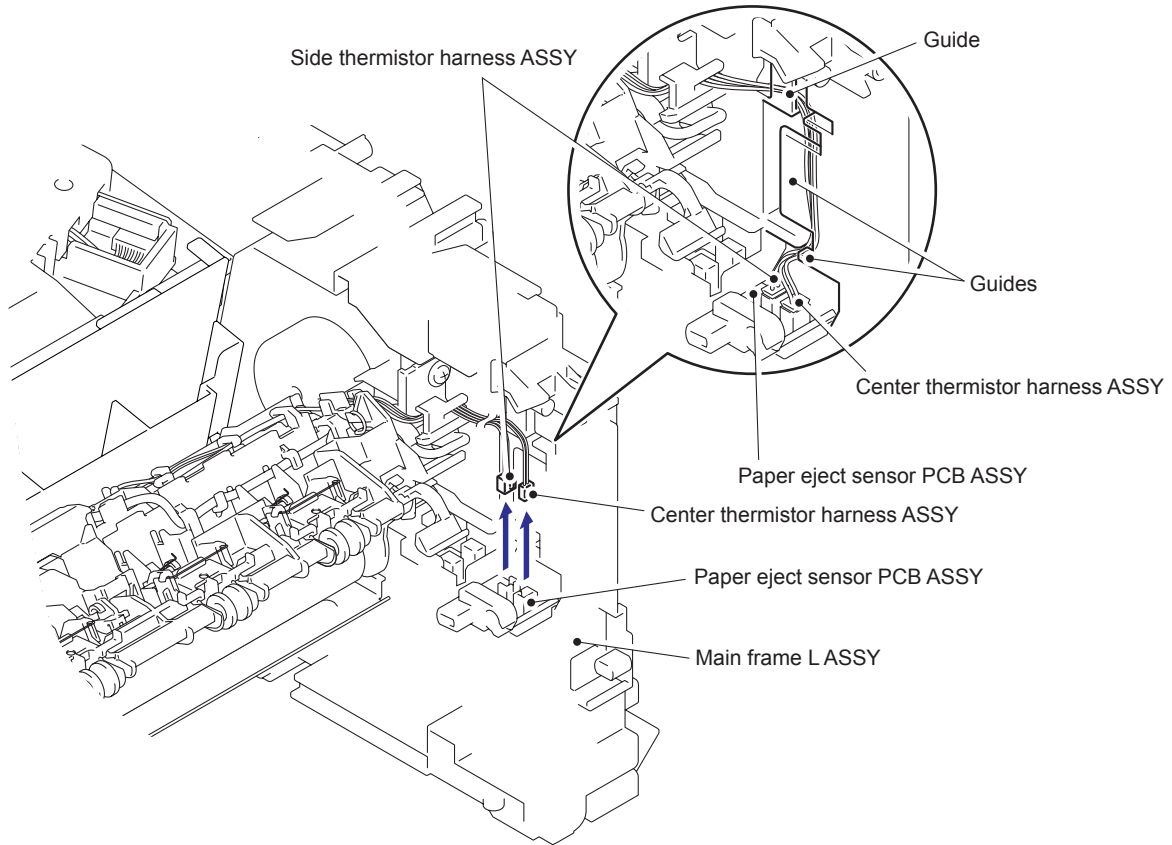


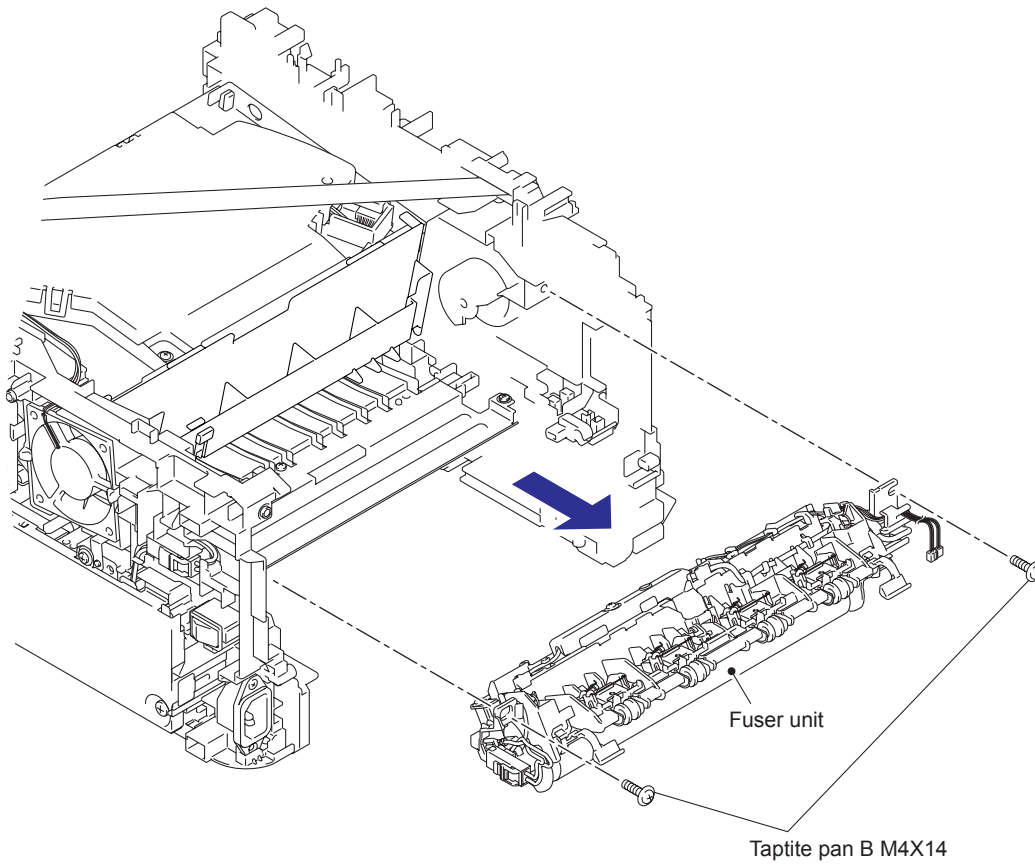
Fig. 3-32

- (4) Disconnect the Connectors of the center thermistor harness ASSY and the side thermistor harness ASSY from the Paper eject sensor PCB ASSY.
- (5) Release the harnesses of the center thermistor harness ASSY and the side thermistor harness ASSY from the Guides of the Main frame L ASSY.



**Fig. 3-33**

(6) Remove the two Taptite pan B M4x14 screws to remove the Fuser unit.



**Fig. 3-34**

## 9.11 Low voltage power supply PCB ASSY

- (1) Remove the FG spring front chute from the LV shield plate cover and the Front chute ASSY.
- (2) Release the Hook part of the FG wire under R from the LV shield plate cover.
- (3) Remove the three Taptite bind B M4x12 screws, the Screw pan (S/P washer) M3.5x6 screw and the Screw pan (S/P washer) M3x12DB screw to remove the LV shield plate cover.

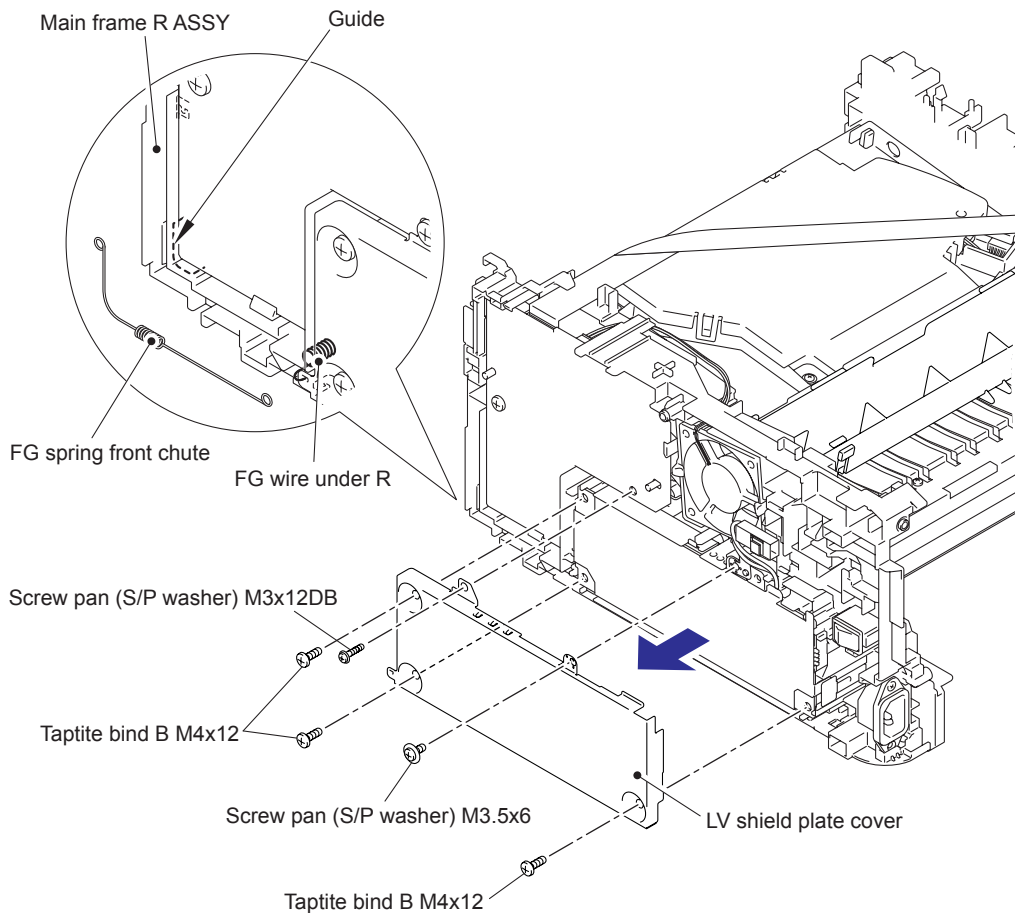
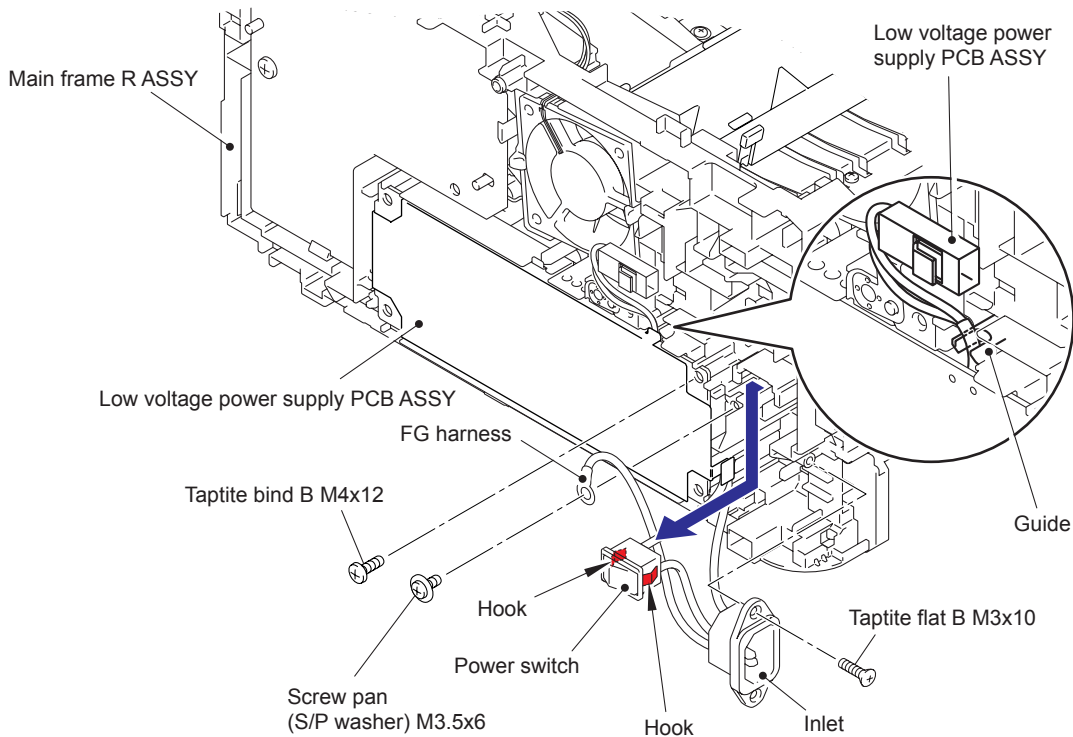


Fig. 3-35

### Assembling Note:

- Hang the FG spring front chute on the Guide of the Main frame R ASSY.

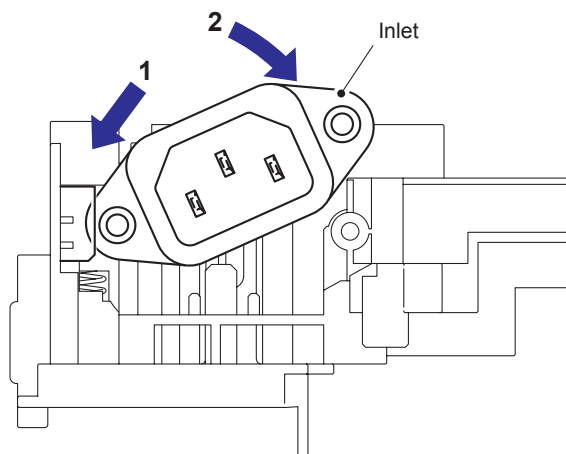
- (4) Remove the Screw pan (S/P washer) M3.5x6 screw to remove the FG harness from the Low voltage power supply PCB ASSY.
- (5) Remove the Taptite flat B M3x10 screw to remove the Inlet of the Low voltage power supply PCB ASSY.
- (6) Release the Hooks to remove the Power switch of the Low voltage power supply PCB ASSY.
- (7) Remove the Taptite bind B M4x12 screw.
- (8) Release the harness of the Low voltage power supply PCB ASSY from the Guide of the Main frame R ASSY.



**Fig. 3-36**

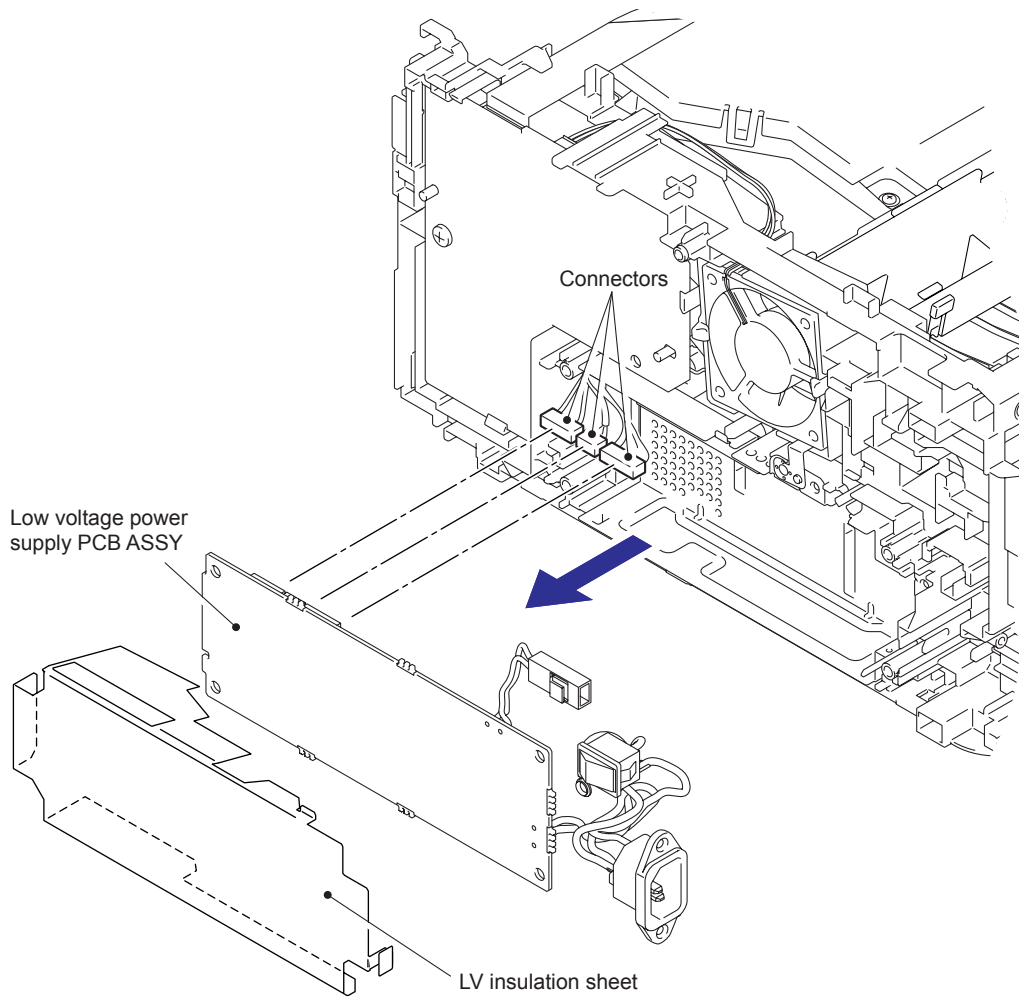
**Assembling Note:**

- When assembling the Inlet, attach as shown in the figure below.



**Fig. 3-37**

- (9) Remove the Low voltage power supply PCB ASSY, and disconnect the three connectors from the rear side.
- (10) Remove the LV insulation sheet.



**Fig. 3-38**

## 9.12 Fuser fan

- (1) Disconnect the Connector of the Fuser fan from the High voltage power supply PCB ASSY.
- (2) Remove the Harness of the Fuser fan from the Guides of the Main frame R ASSY.
- (3) Release the Hooks to remove the Fuser fan.

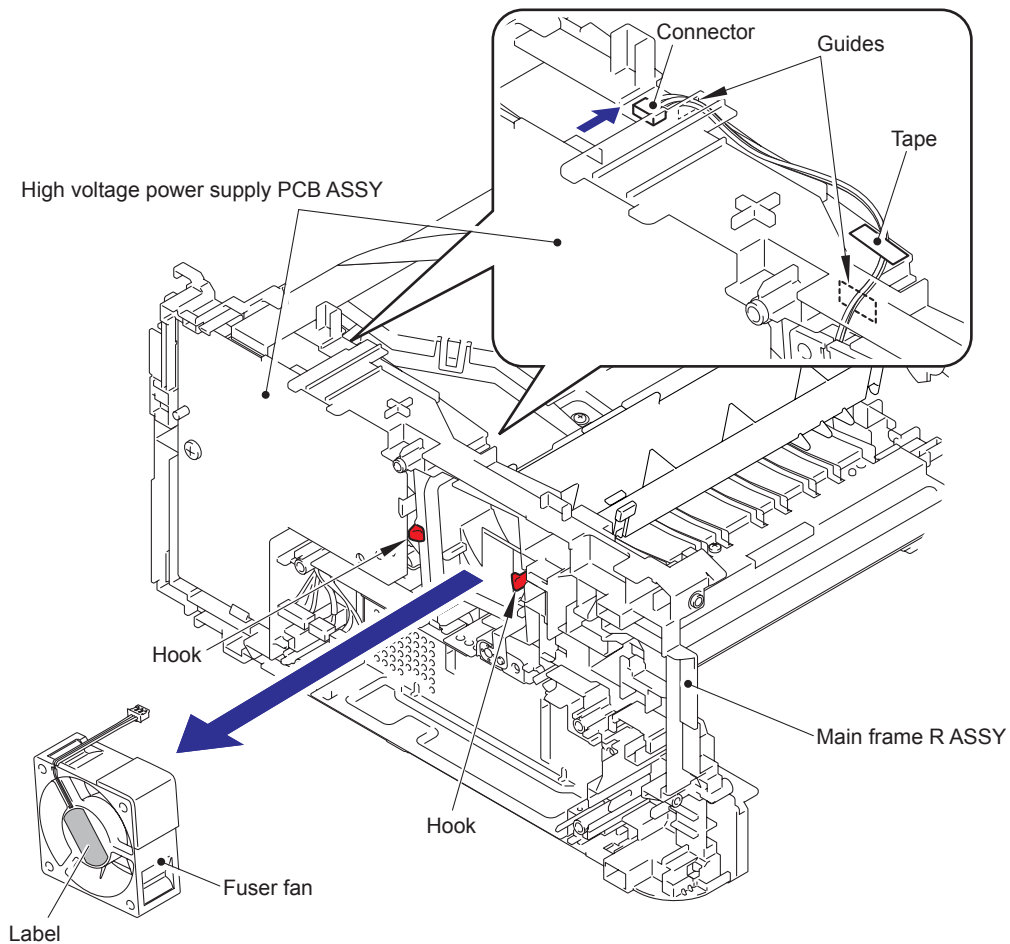


Fig. 3-39

### Assembling Note:

- When assembling the Fuser fan, attach the Fuser fan after inserting the Harness into the Guides of the Main frame R ASSY.
- When assembling the Fuser fan, place it so that the attached label faces outwards.
- When assembling the Fuser fan, secure the harness to the position of figure above with the Tape.

### 9.13 High voltage power supply PCB ASSY

- (1) Remove the Flat cable from the Guides of the Main frame L ASSY, and disconnect the connector from the High voltage power supply PCB ASSY.
- (2) Remove the Taptite bind B M4x12 screw.
- (3) Release the Hooks to remove the High voltage power supply PCB ASSY.

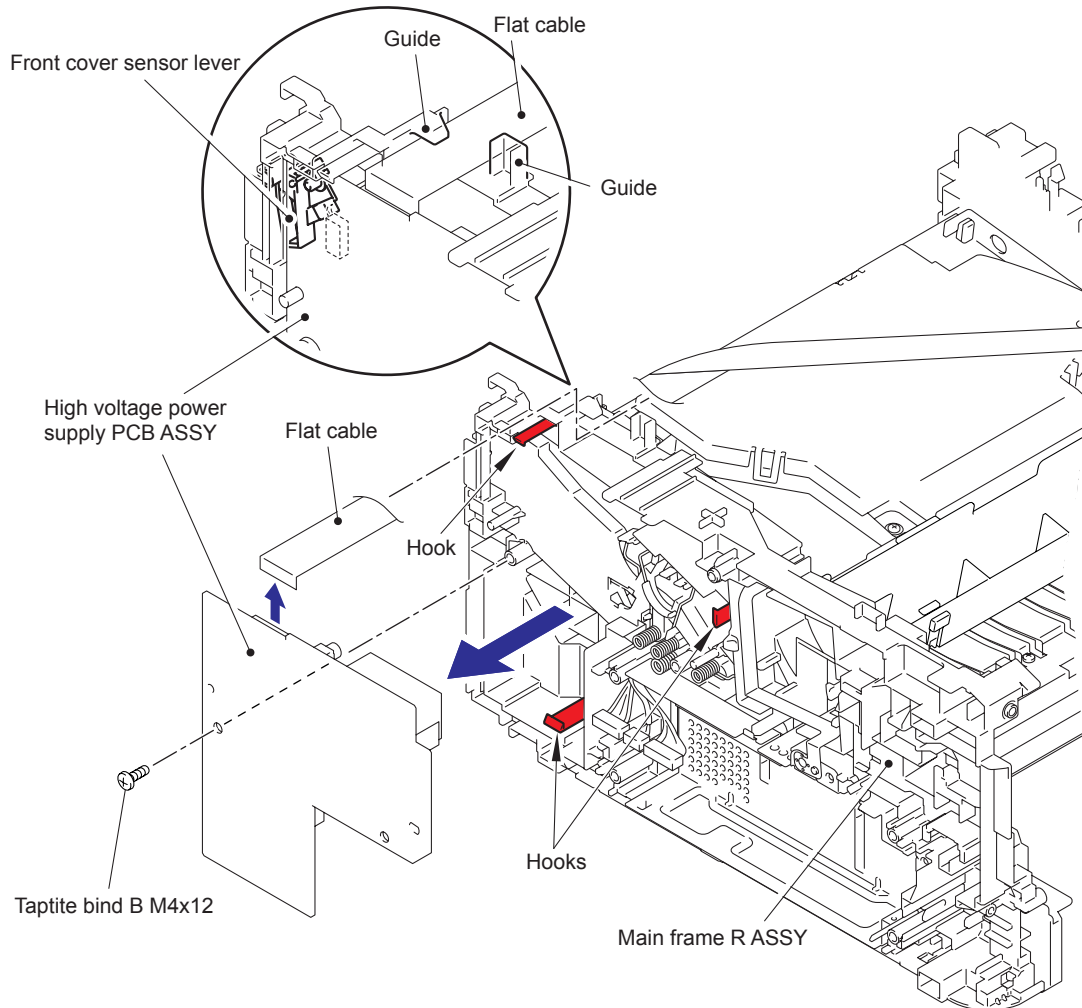


Fig. 3-40

**Assembling Note:**

- Assemble the Front cover sensor lever after assembling the High voltage power supply PCB ASSY.

## 9.14 Panel PCB ASSY

- (1) Rotate the Main body 180° to the side of Main frame L ASSY.
- (2) Disconnect the Flat cable of the Panel PCB ASSY from the Main PCB ASSY, and remove the Flat cable of the Panel PCB ASSY from the Guide of the Main frame L ASSY.
- (3) Release the Hooks to remove the Panel PCB ASSY.
- (4) Disconnect the Connector from the bottom side of the Panel PCB ASSY.

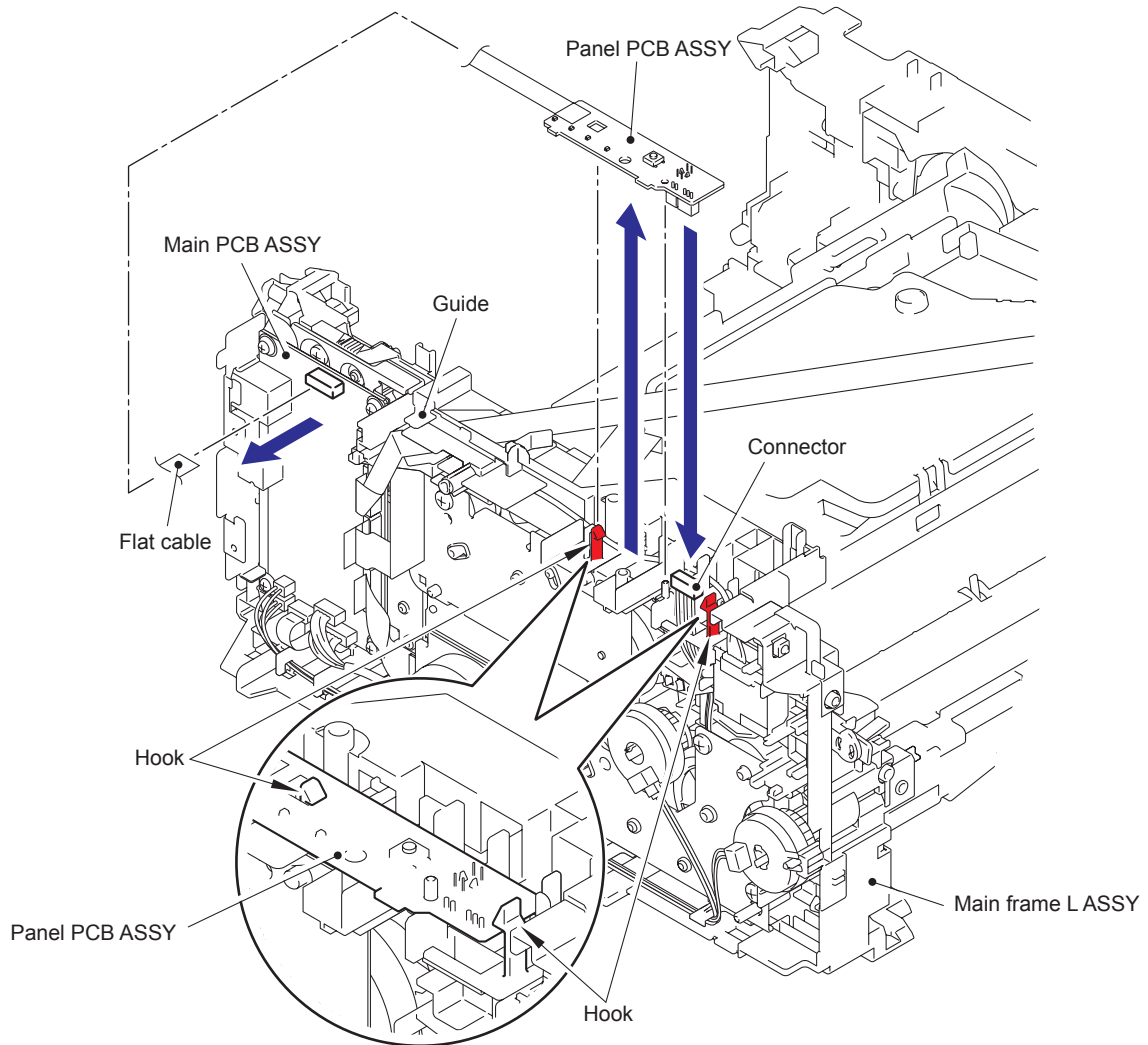


Fig. 3-41

## 9.15 Filter

- (1) Release the Hooks to remove the Air duct.
- (2) Pull the Rib of the Air duct to the direction of the arrow 2a, and remove the Filter.

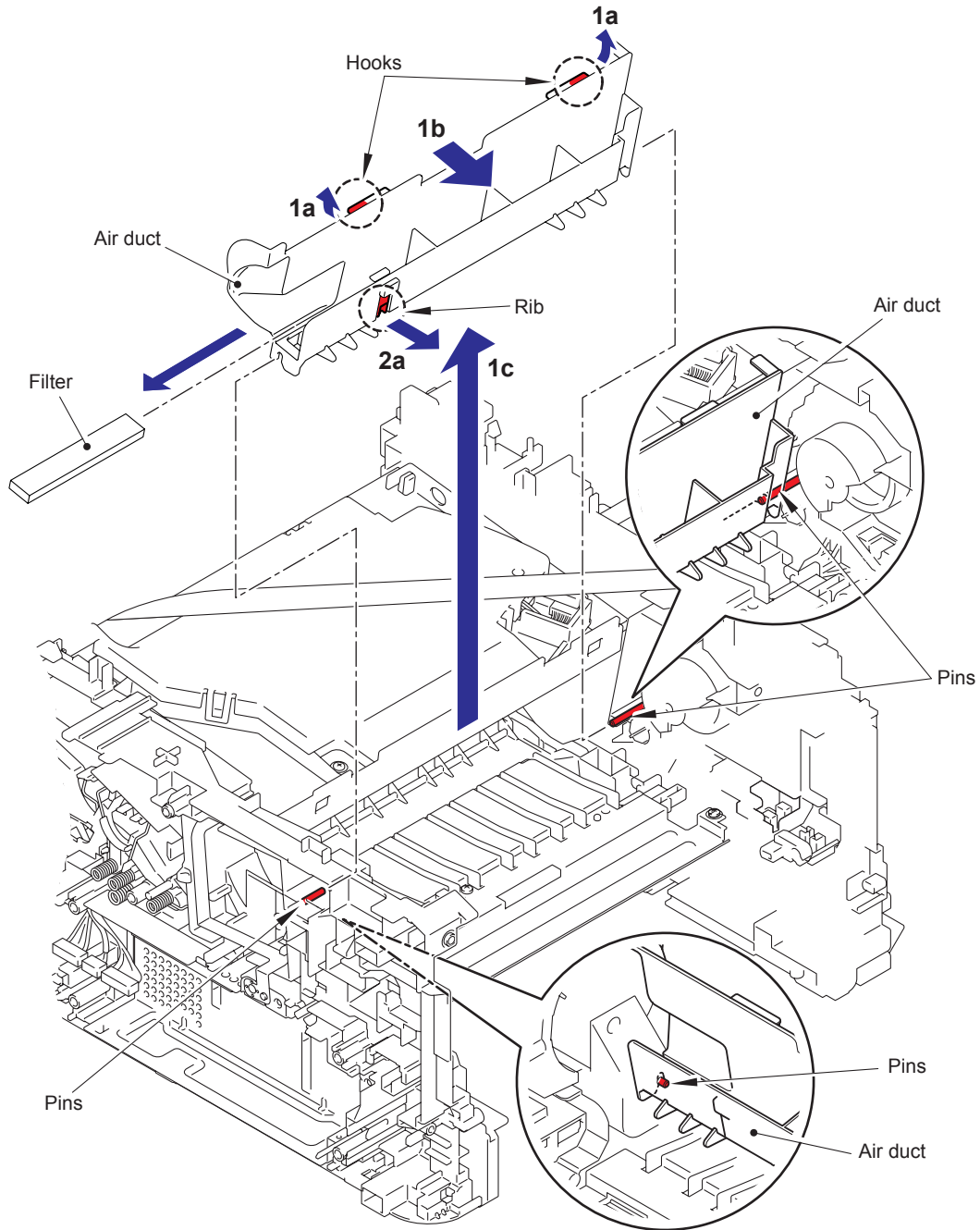


Fig. 3-42

### Assembling Note:

- When assembling the Air duct, align the notch part of the Air duct with the Pins of the main body.

## 9.16 Laser Unit

- (1) Disconnect the flat cable of the high voltage power supply PCB ASSY from the main PCB ASSY, and remove the flat cable of the high voltage power supply PCB ASSY from the guide of the main frame L ASSY.
- (2) Disconnect the flat cable of the laser unit from the laser unit.
- (3) Remove the flat cable of the laser unit from the guide of the main frame L ASSY, and disconnect the flat cable of the laser unit from the main PCB ASSY.
- (4) Remove the four taptite cup S M3x8 SR screws, and remove the laser unit.

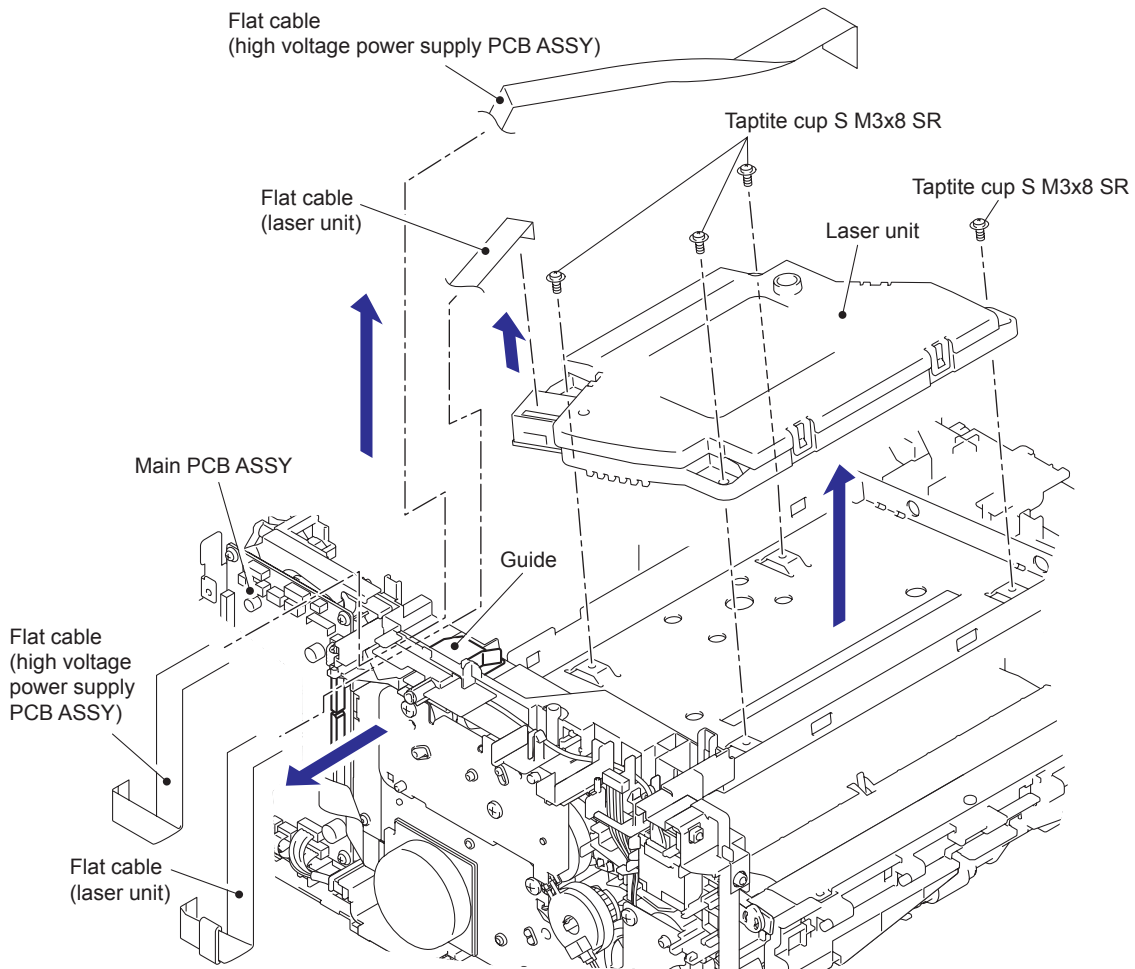


Fig. 3-43

### Assembling Note:

- Do not touch the Lens of the Laser unit directly.

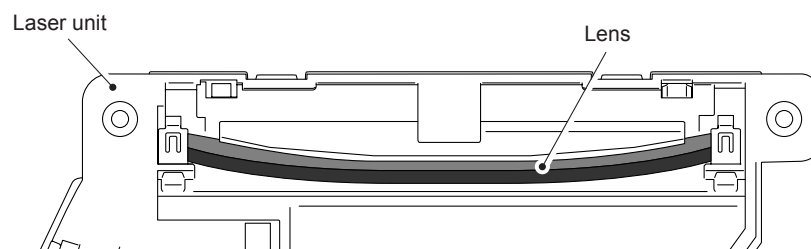


Fig. 3-44

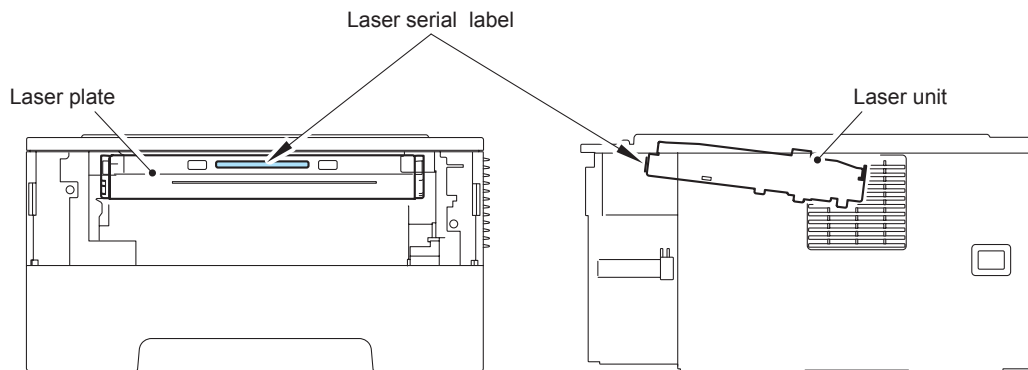
**Assembling Note:**

- There are two types of Laser Unit that can be ordered as a spare part. (SF type and SH type)  
When replacing the Laser unit, be sure to order and assemble the same type of the Laser unit that was attached to the printer.

**<How to identify the type of Laser unit and the position of label>**

Check the first two characters of the Laser serial label.

- SF type : SFxxxxxxVXXYY
- SH type : SHxxxxxxVXXYY



**Fig. 3-45**

**Assembling Note:**

- Attach the Laser serial label as shown in the figure (on laser plate) above after replacing the laser unit.

### 9.17 Wireless LAN PCB ASSY (Wireless network model only)

- (1) Remove the Harness of the Wireless LAN PCB ASSY from the Guides of the Main frame L ASSY.
- (2) Disconnect the Connector of the Wireless LAN PCB ASSY from the Main PCB ASSY.
- (3) Release the Hooks to remove the Wireless LAN PCB ASSY.

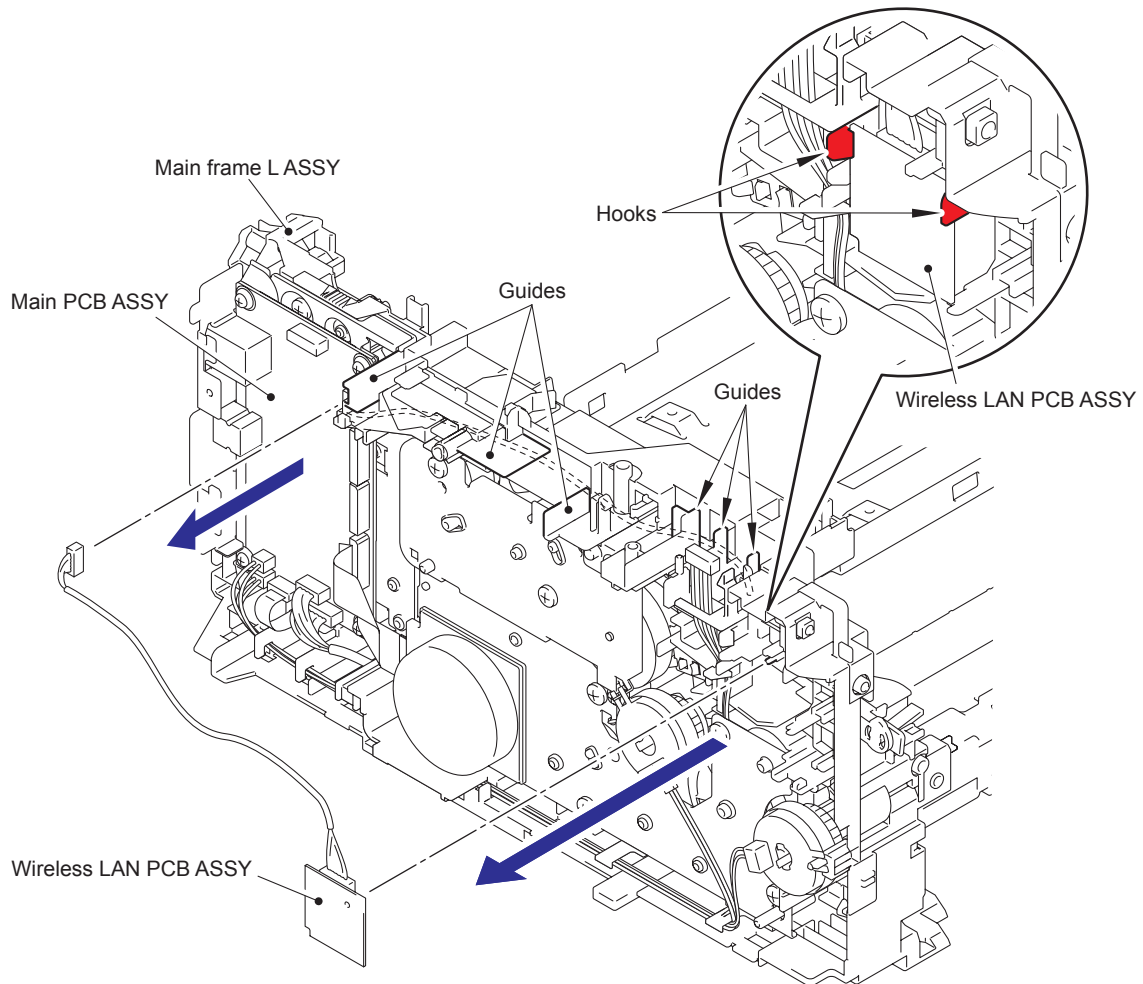


Fig. 3-46

## 9.18 Pick-up Roller Holder ASSY

- (1) Turn the Printer upside down.
- (2) Push the Link arm to the direction of the arrow 2, and turn the Pick-up roller holder ASSY to release the boss.
- (3) Slide the Pick-up roller holder ASSY to the direction of the arrow 3 to release it from the shaft, and remove the Pick-up roller holder ASSY from the Main body.

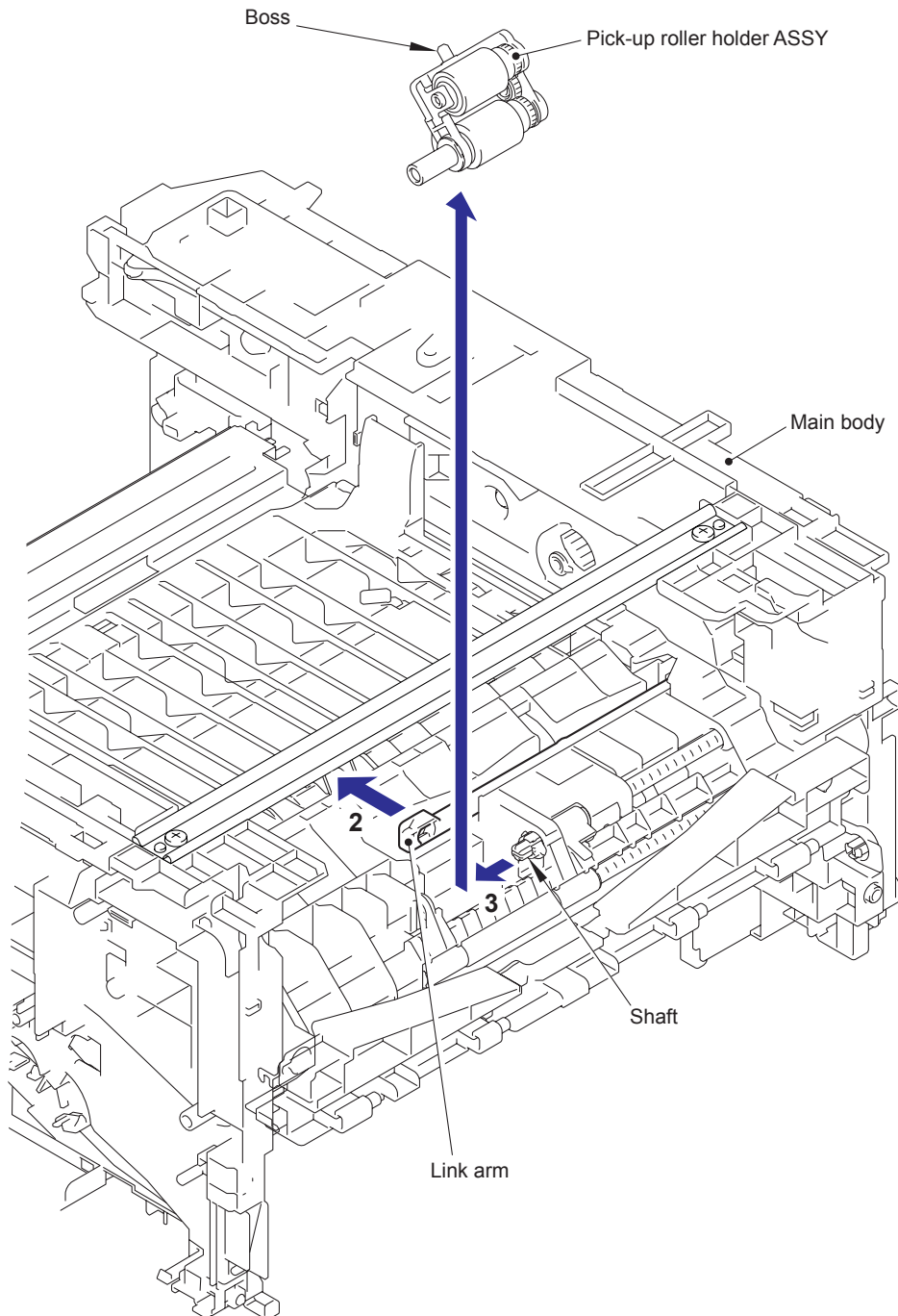
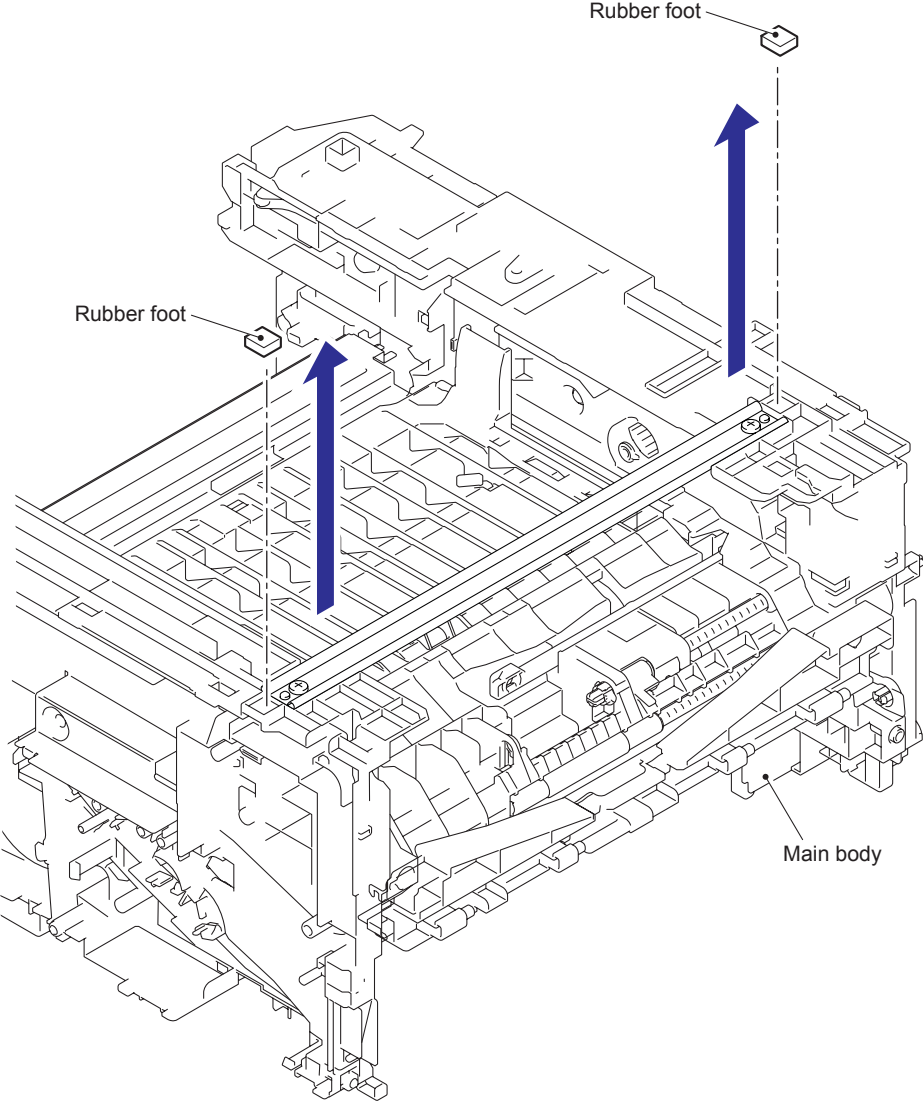


Fig. 3-47

**9.19 Rubber Foot**

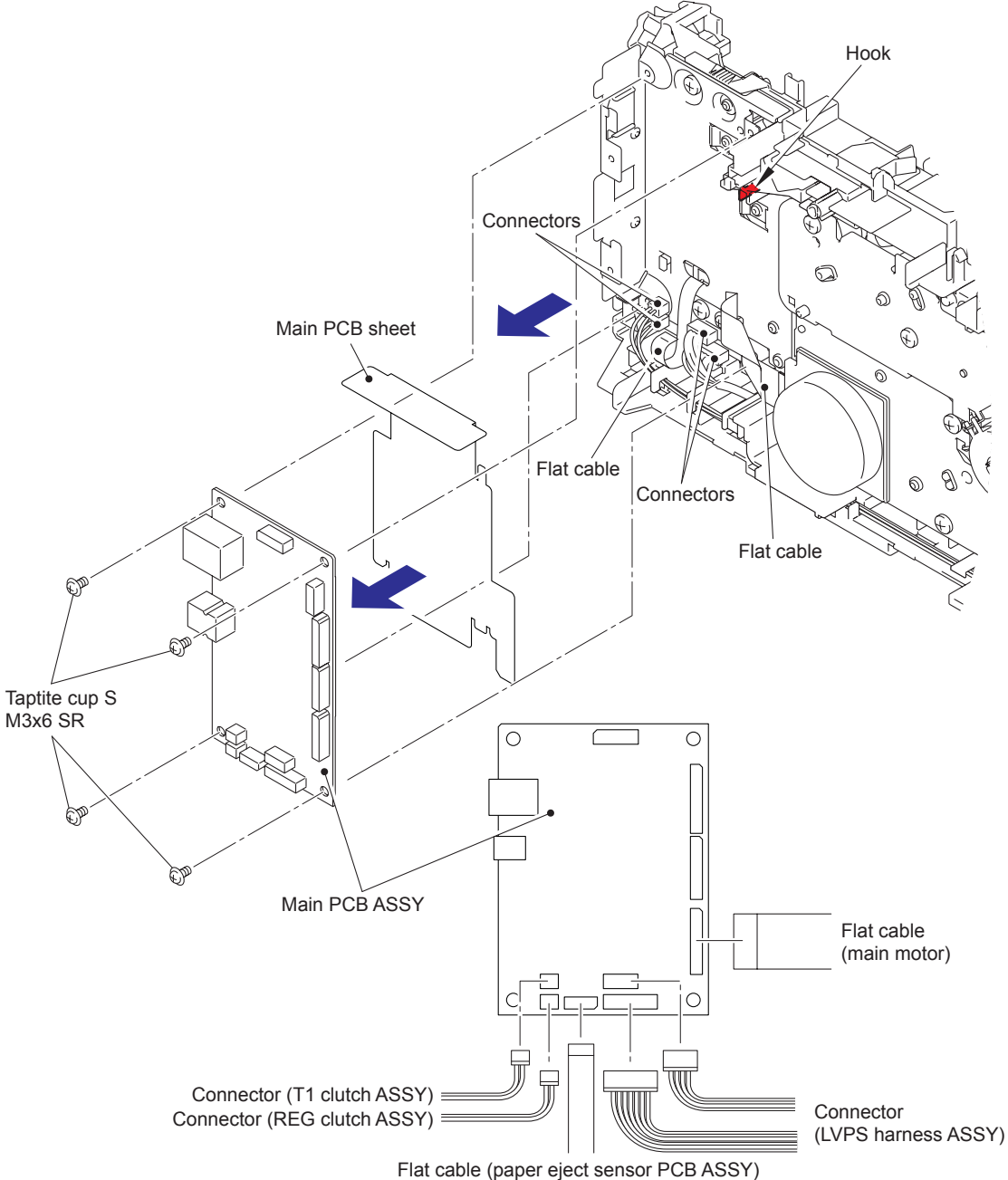
(1) Remove the two Rubber foots from the Main body.



**Fig. 3-48**

### 9.20 Main PCB ASSY

- (1) Turn the Printer upside down.
- (2) Disconnect the two Flat cables and the four Connectors from the Main PCB ASSY.
- (3) Remove the four Taptite cup S M3x6 SR screws.
- (4) Release the Hook to remove the Main PCB ASSY and the Main PCB sheet.



**Fig. 3-49**

## 9.21 T1 Clutch ASSY, REG Clutch ASSY

- (1) Remove the Harness of the T1 clutch ASSY and the REG clutch ASSY from the Guides of the Main frame L ASSY.
- (2) Release the Hook to remove the T1 clutch ASSY.
- (3) Remove the retaining ring.
- (4) Release the hook to remove the REG clutch ASSY.

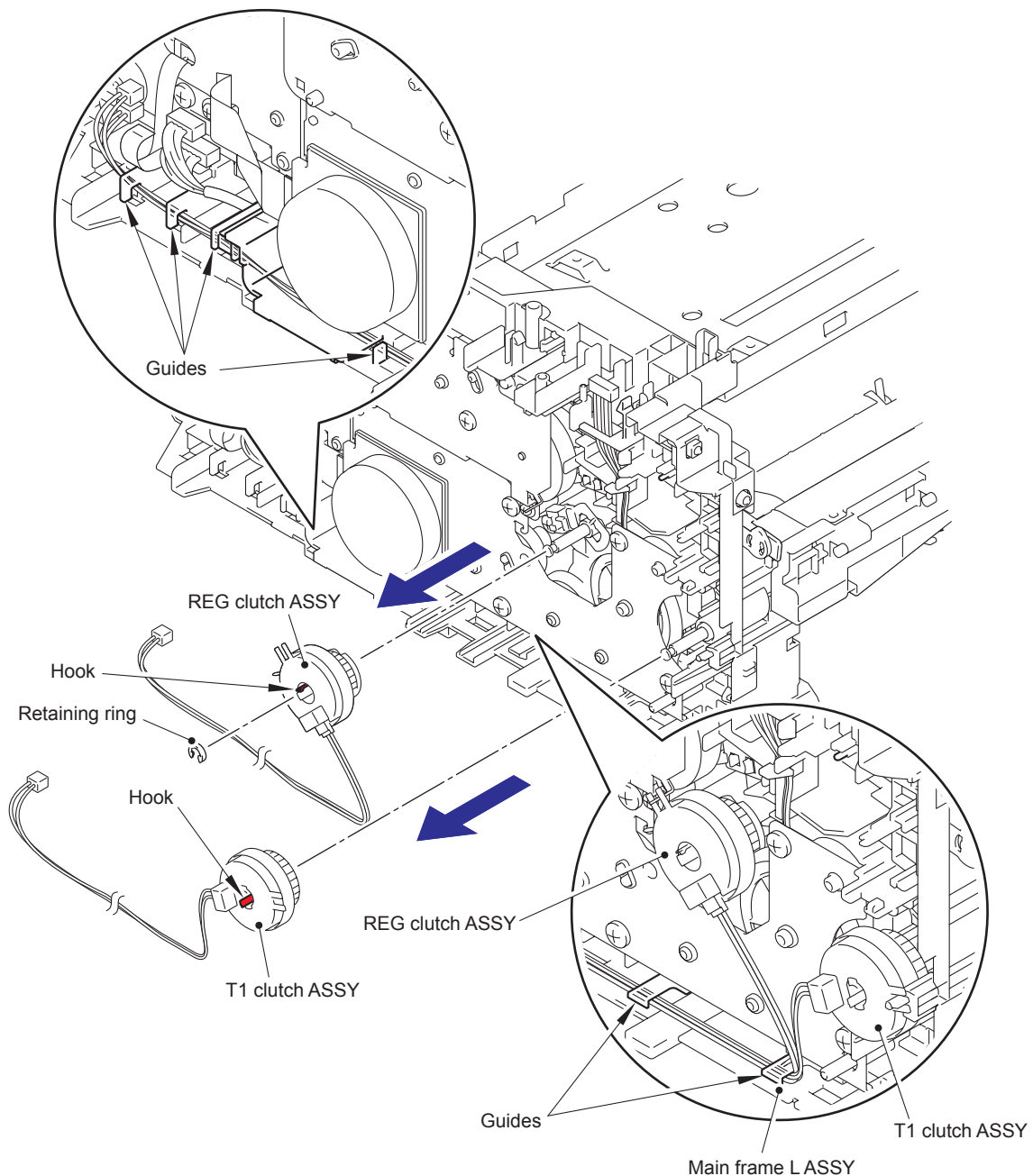
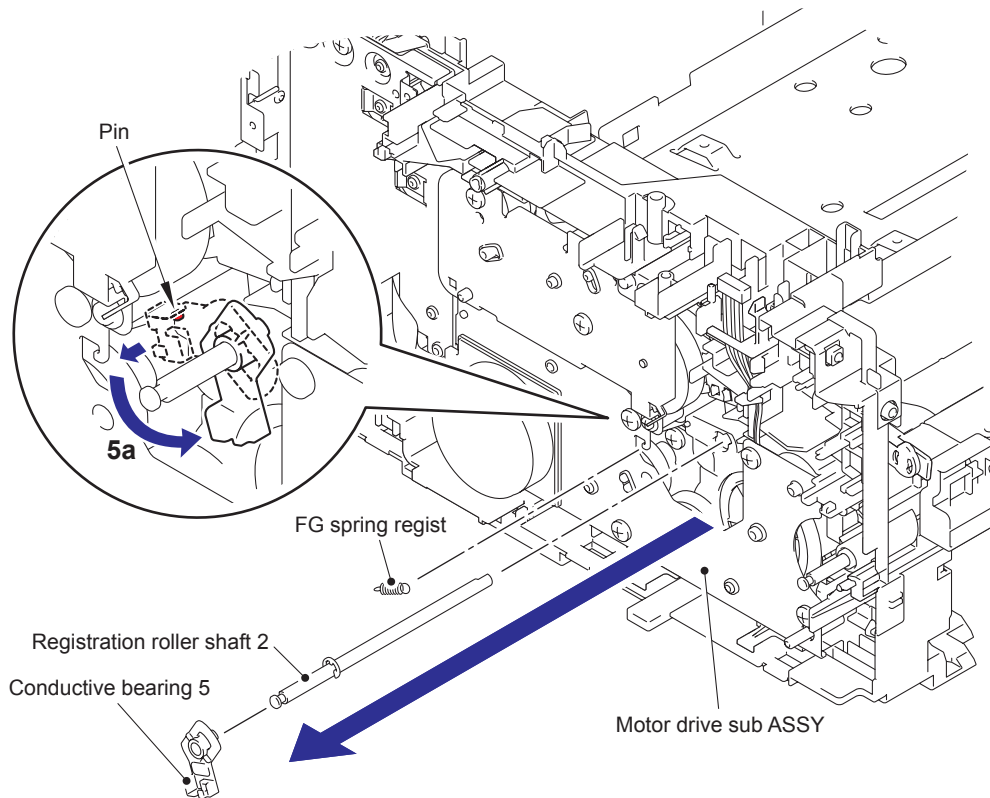


Fig. 3-50

### Assembling Note:

- When wiring the Harnesses of the T1 clutch ASSY and the REG clutch ASSY to the Guides of the Main frame L ASSY, check that there is no slack in the Harnesses.

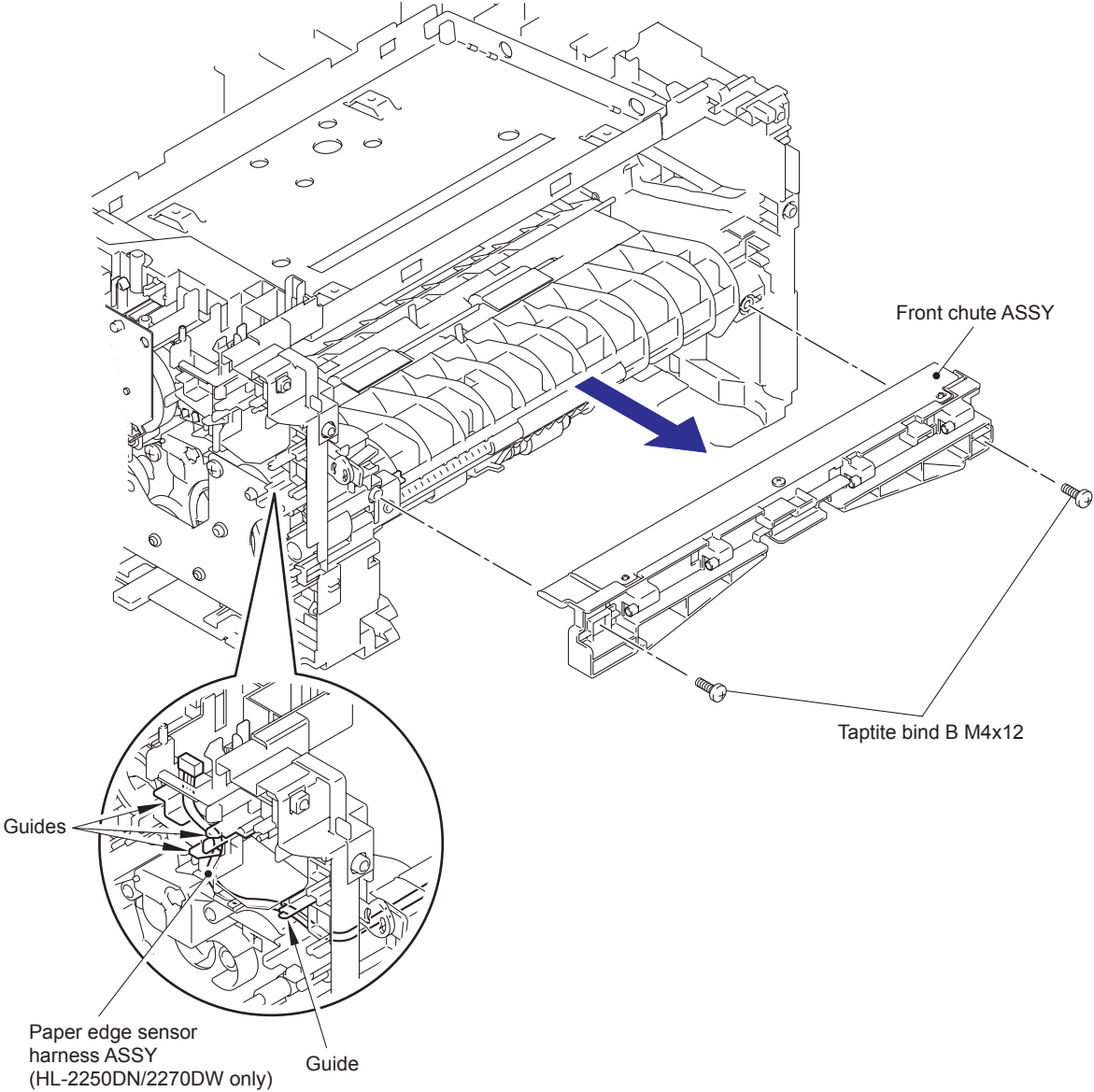
- (5) Remove the FG spring regist from the Motor drive sub ASSY and the Conductive bearing 5.
- (6) Remove the Conductive bearing 5 from the Pin of the Main frame L ASSY, and turn it to the direction of the arrow 5a until the releasing position, and pull out the Conductive bearing 5 from the Registration roller shaft 2.
- (7) Pull out the Registration roller shaft 2.



**Fig. 3-51**

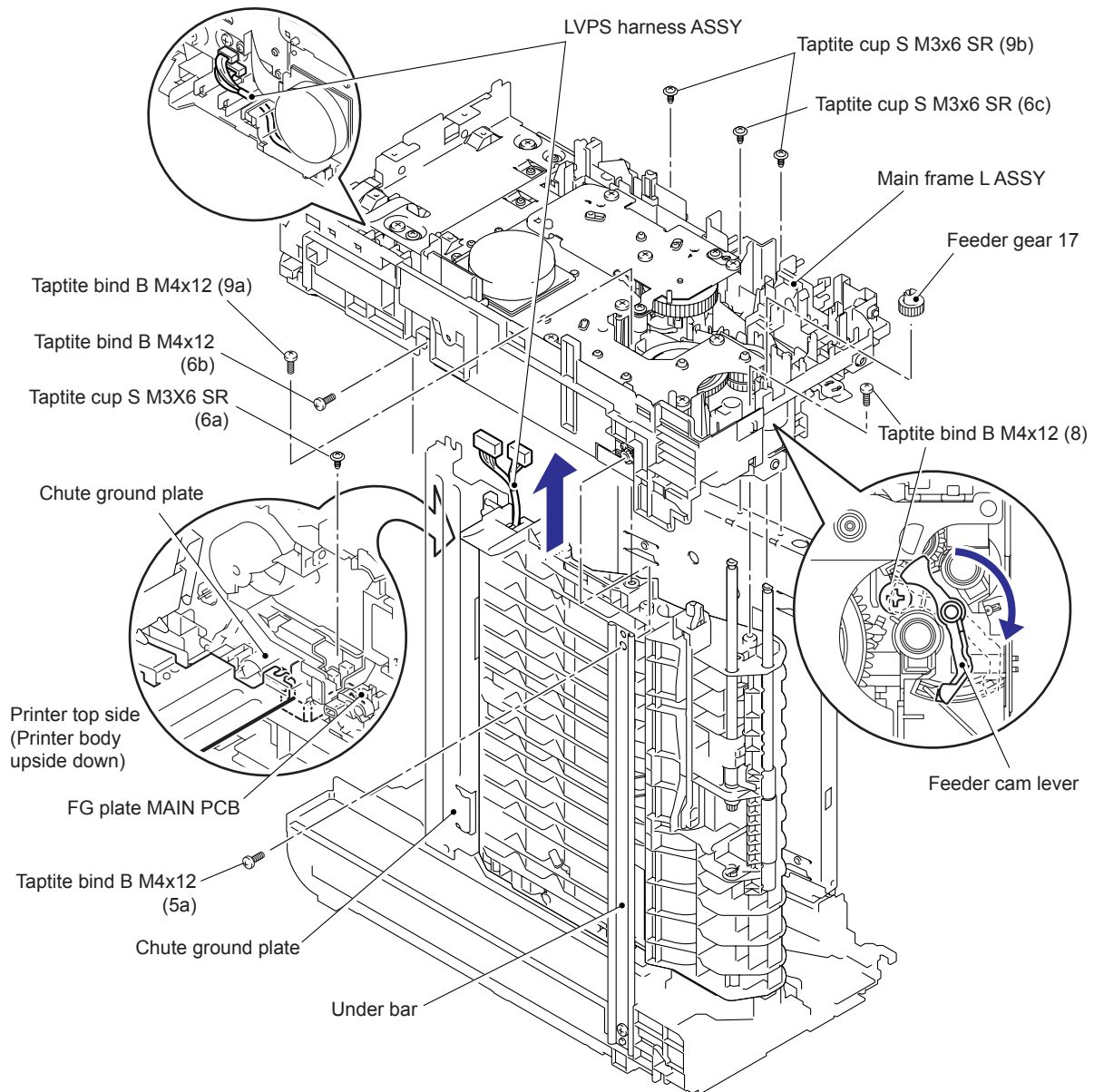
**9.22 Main Frame L ASSY**

- (1) Remove the two Taptite bind B M4x12 screws to remove the Front chute ASSY.
- (2) Remove the Paper edge sensor harness ASSY from the Guides of the Main frame L ASSY.



**Fig. 3-52**

- (3) Place the printer so that the Main frame L ASSY is at the top.
- (4) Remove the LVPS harness ASSY from the Guide of the Main frame L ASSY.
- (5) Remove the Taptite bind B M4x12 screw 5a (for Under bar).
- (6) Remove the Taptite cup S M3X6 SR screw 6a (for Chute ground plate), the Taptite bind B M4x12 screw 6b (for PF frame ASSY) and the Taptite cup S M3x6 SR screw 6c (for FG plate laser L).
- (7) Release the Hook to remove the Feeder gear 17.
- (8) Turn the Feeder cam lever to the direction of the arrow, and remove the Taptite bind B M4x12 screw 8.
- (9) Remove the Taptite bind B M4x12 screw 9a and the two Taptite cup S M3x6 SR screws 9b to remove the Main frame L ASSY.



**Fig. 3-53**

**Assembling Note:**

- When assembling the Main frame L ASSY, check that there is the Chute ground plate on the upper side of the FG plate MAIN PCB.

## 9.23 Develop Drive Sub ASSY, Develop Gear Joint/52

- (1) Remove the Taptite cup S M3X6 SR screw and three Taptite bind B M4x12 screws to remove the Develop drive sub ASSY.

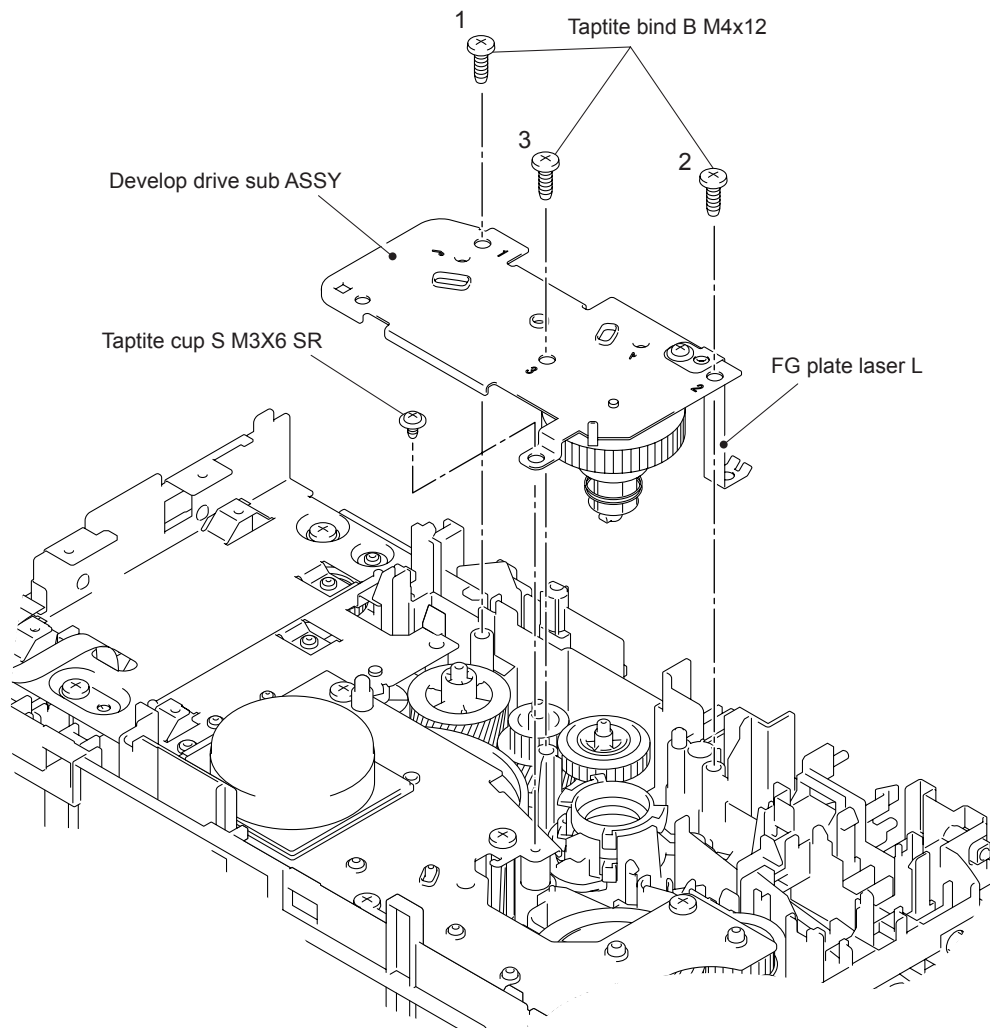
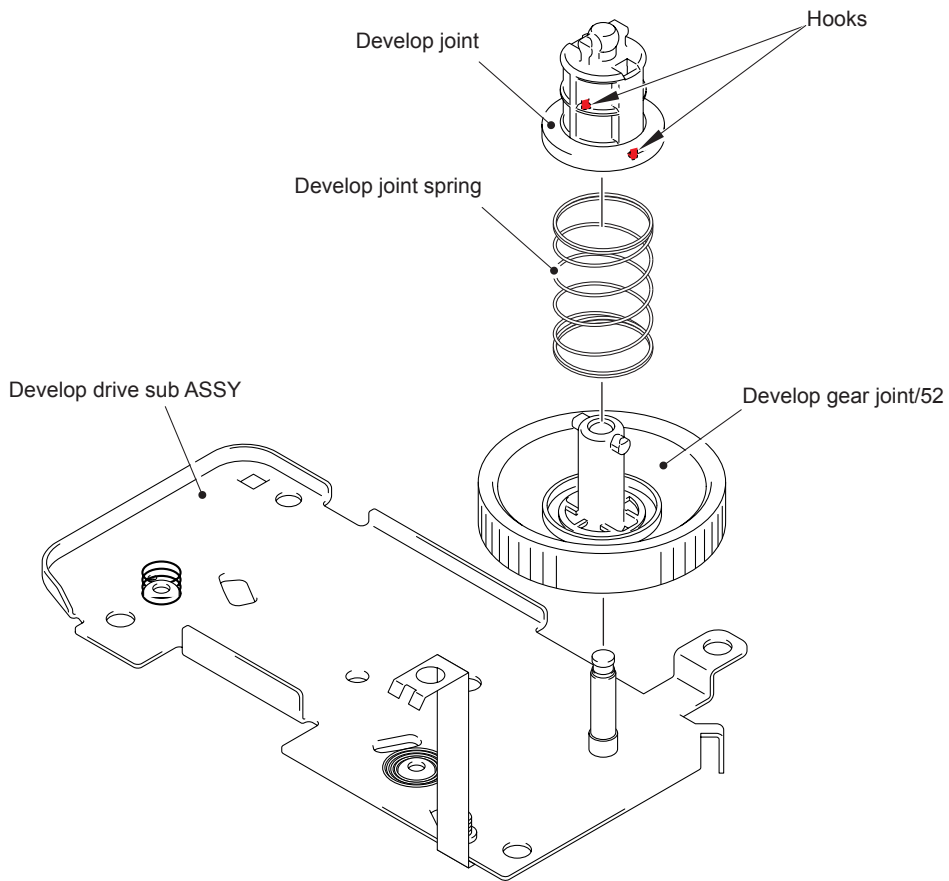


Fig. 3-54

### Assembling Note:

- When assembling the Develop drive sub ASSY, tighten the three Taptite bind B M4x12 screws in numerical order written in the plate.
- Be careful not to bent the FG plate laser L.

- (2) Place the Develop drive sub ASSY as shown in the figure below.
- (3) Be careful not to damage the Hooks of the Develop joint and release the Hooks to remove the Develop joint, and then remove the Develop joint spring and the Develop gear joint/52.



**Fig. 3-55**

## 9.24 Motor Drive Sub ASSY, Main Motor

- (1) Remove the six Taptite bind B M4x12 screws to remove the Stopper and Motor drive sub ASSY.

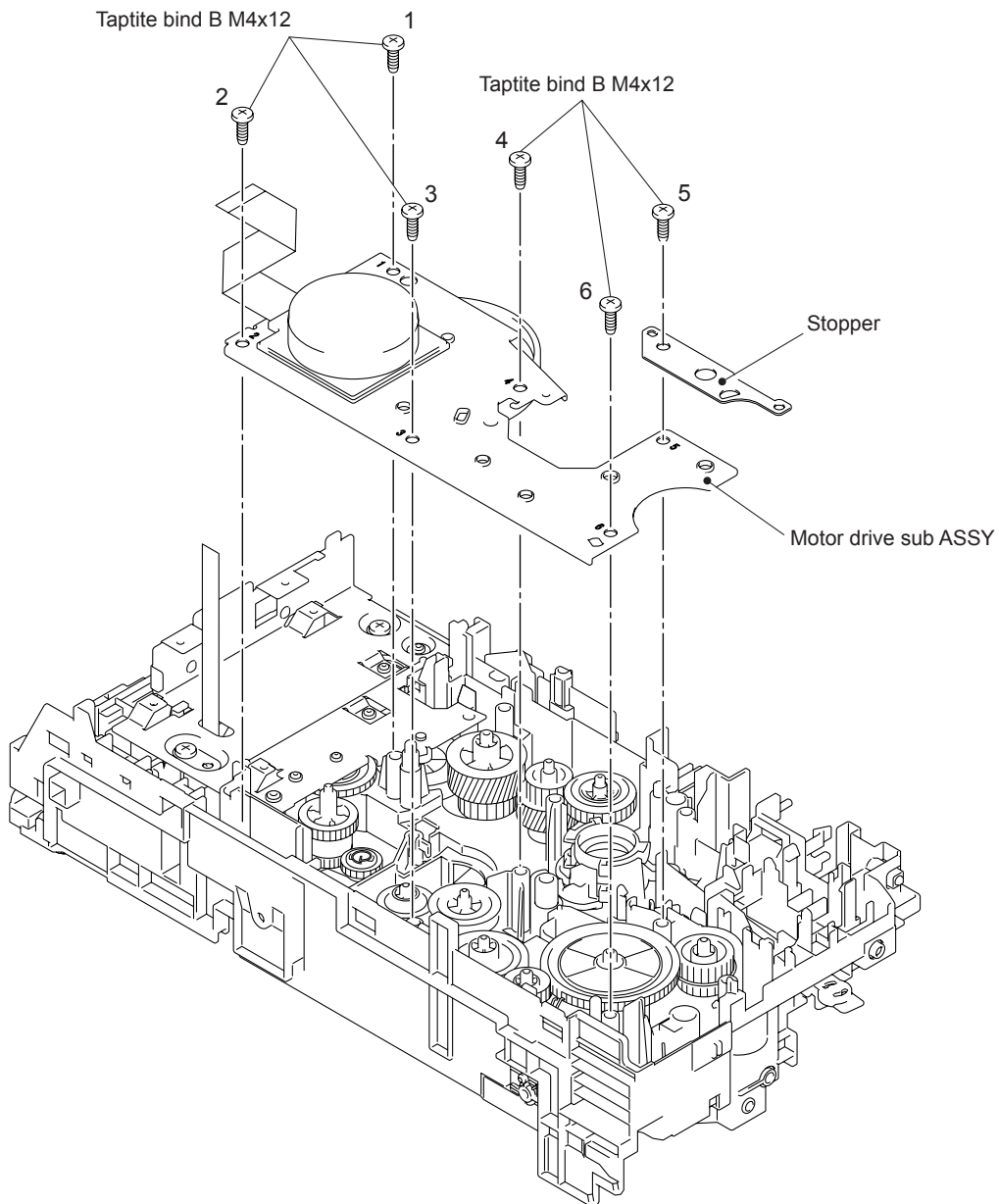
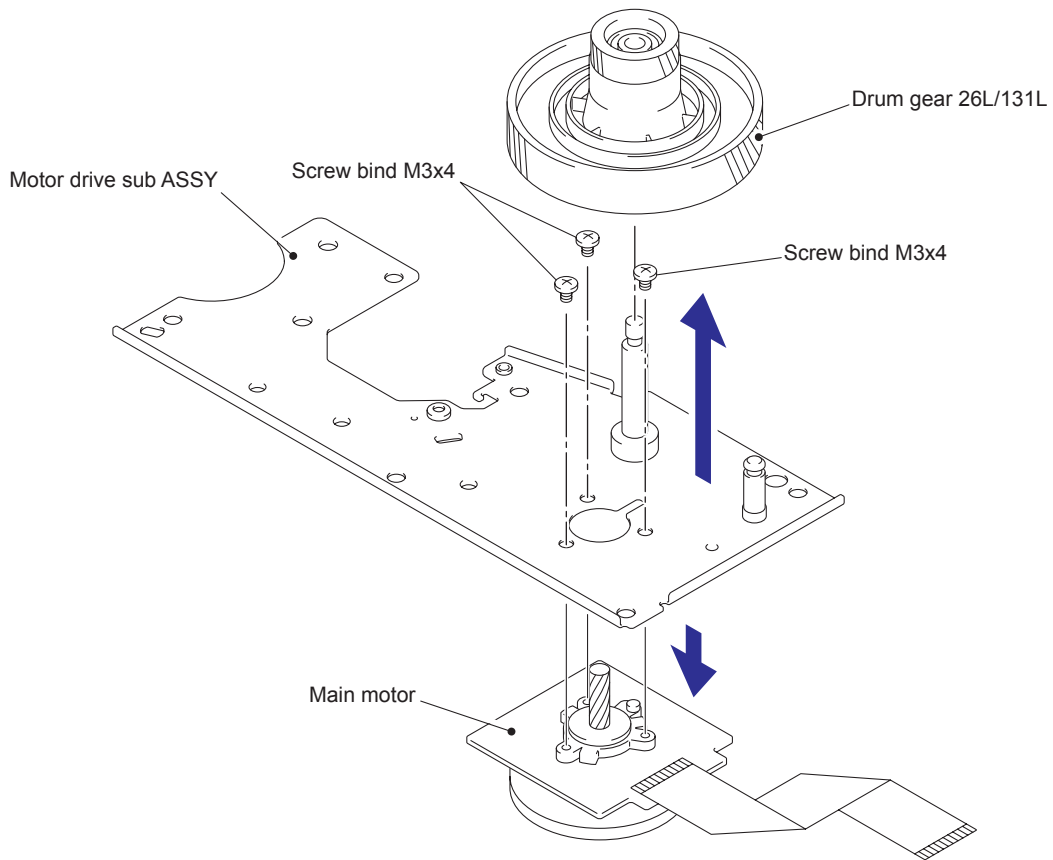


Fig. 3-56

### Assembling Note:

- When assembling the Motor drive sub ASSY, tighten the six Taptite bind B M4x12 screws in numerical order written in the plate.

- (2) Place the Motor drive sub ASSY as shown in the figure below.
- (3) Remove the Drum gear 26L/131L.
- (4) Remove the three Screw bind M3x4 screws to remove the Main motor.



**Fig. 3-57**

## 9.25 Paper Eject Sensor PCB ASSY

- (1) Remove the Taptite cup S M3x6 SR screw and the two Taptite bind B M4x12 screws.
- (2) Release the Hooks to remove the Main PCB shield.

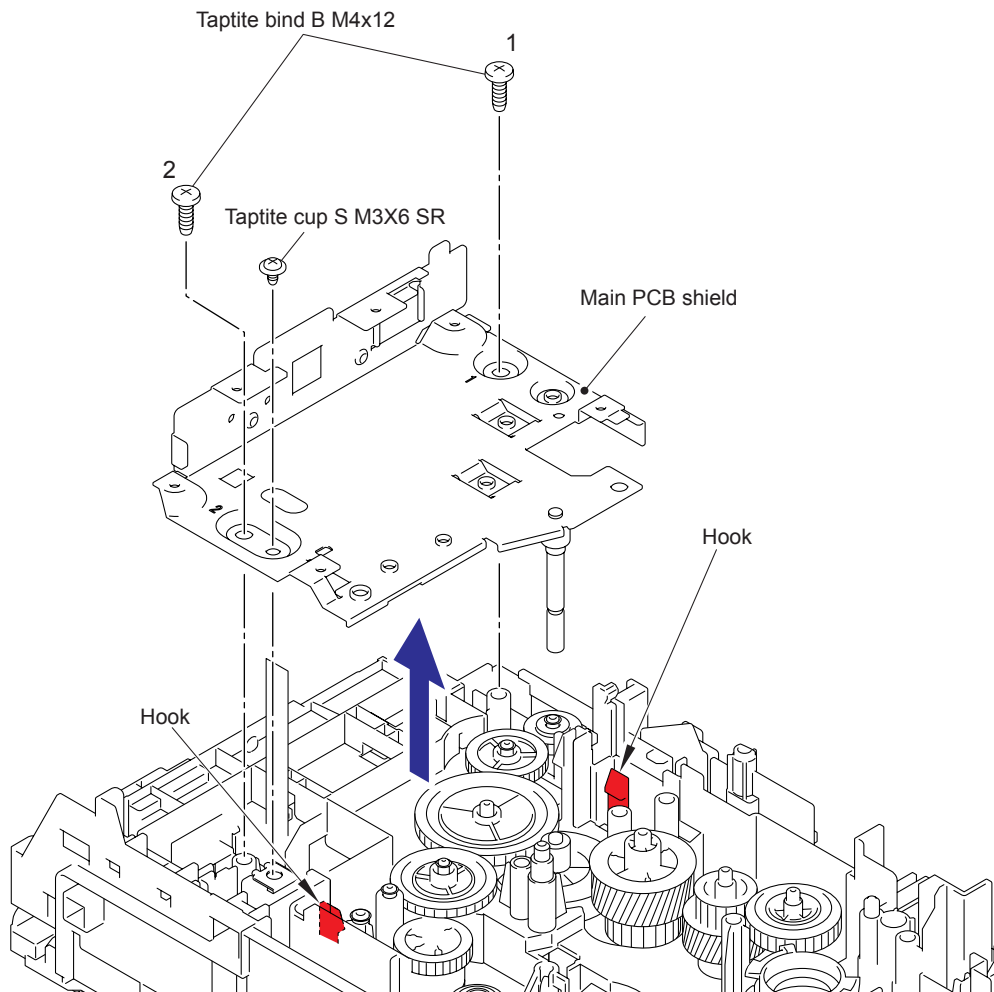
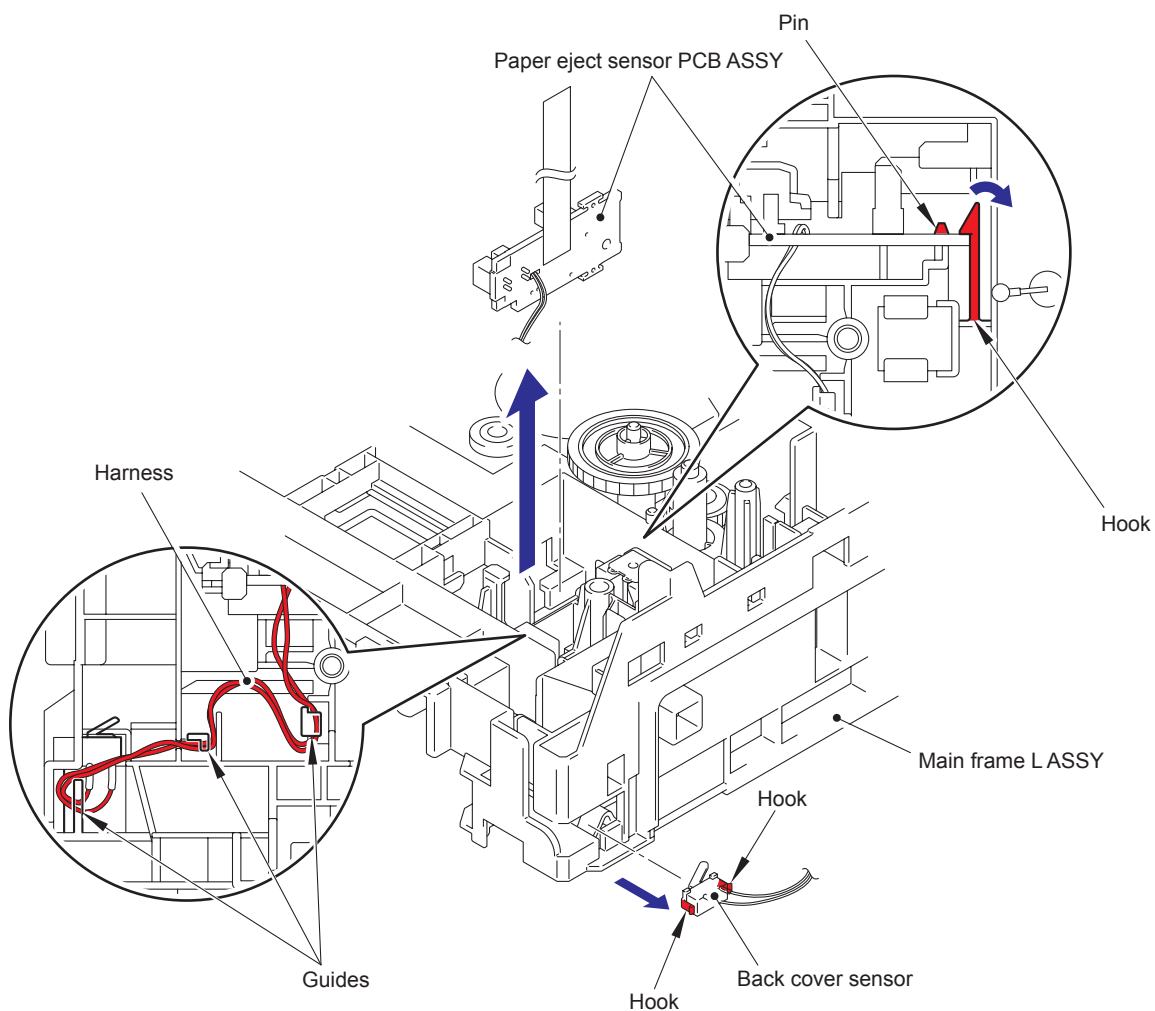


Fig. 3-58

### Assembling Note:

- When assembling the Main PCB shield, insert the Flat cable of the Paper eject sensor PCB ASSY into the hole of the Main PCB shield.
- When assembling the Main PCB shield, tighten the two Taptite bind B M4x12 screws in numerical order written in the plate.

- (3) Release the Hook to remove the Paper eject sensor PCB ASSY from the Pin of the Main frame L ASSY.
- (4) Remove the Harness of the Paper eject sensor PCB ASSY from the Guides of the Main frame L ASSY.
- (5) Release the Hooks to remove the Back cover sensor.



**Fig. 3-59**

**Assembling Note:**

- When assembling the Back cover sensor, attach it while pushing the center of the rear side of the Back cover sensor.

## 9.26 Fuser Gear 28/34

- (1) Remove the Ejector gear 40.
- (2) Remove the Fuser gear 28/34.

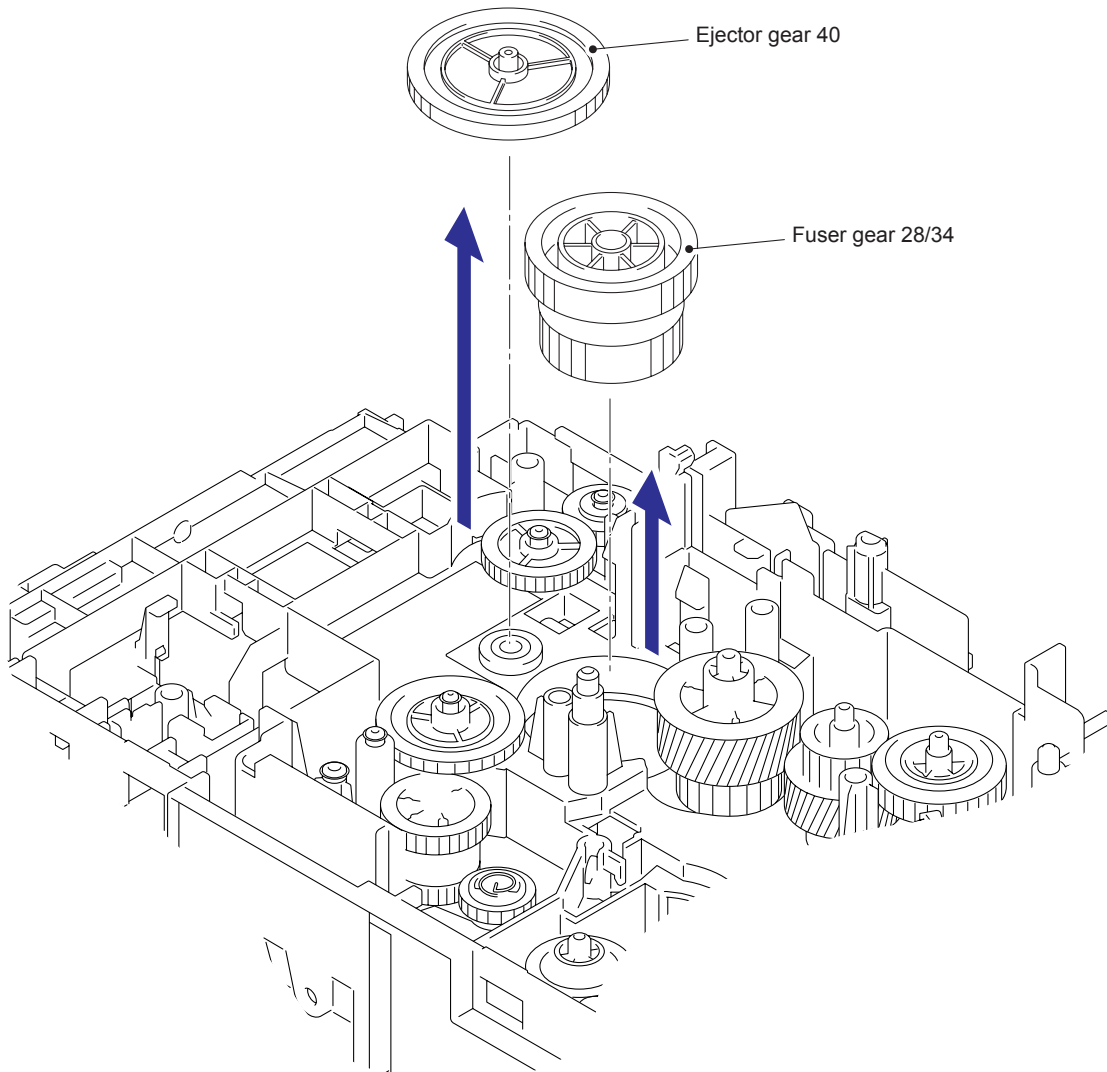


Fig. 3-60

---

## CHAPTER 4 ADJUSTMENTS AND UPDATING OF SETTINGS, REQUIRED AFTER PARTS REPLACEMENT

---

### 1. IF YOU REPLACE THE MAIN PCB ASSY

---

#### <What to do when replacing the main PCB ASSY>

- Rewriting the Firmware (Main Program)
- Setting the default paper size
- Setting the serial number
- Inputting the adjusted value of the laser unit

#### Note:

- Since the counters are reset when the main PCB ASSY is replaced, the consumables and/ or periodical replacement parts might reach the end of the life before the message is displayed.

#### <What you need to prepare>

- (1) A USB cable
- (2) Computer (Windows<sup>®</sup> XP/2000 or later)  
Create folder, for example "hl2200" folder on the C drive.
- (3) Service Setting Tool (brusbn.zip)  
Copy it into the "hl2200" folder that has been created on the C drive. Extract the copied file and run "BrUsbsn.exe" file by double-clicking.
- (4) Download Utility (FILEDG32.EXE)  
Copy it into the "hl2200" folder that has been created on the C drive.
- (5) Maintenance Driver (MaintenanceDriver.zip)  
If Maintenance Printer Driver is not installed to your PC, copy it into the "hl2200" folder that has been created on the C drive. Extract the copied file. (Refer to "INSTALLING THE MAINTENANCE PRINTER DRIVER" in APPENDIX 3.)
- (6) Firmware

Main Program : LZXXXX_\$.bif	LZXXXX: First six digits are a parts number of the firmware. \$: Alphabet representing the revision of the firmware
------------------------------	--

- (7) Setting file of the default paper size  
DefaultPaperA4.pjl (A4 size)  
DefaultPaperLtr.pjl (Letter size)  
DefaultPaperIsr.pjl (A4 size, Israeli font for Israel)

## 1.1 Rewriting the Firmware (Main Program)

### 1.1.1 Checking firmware version

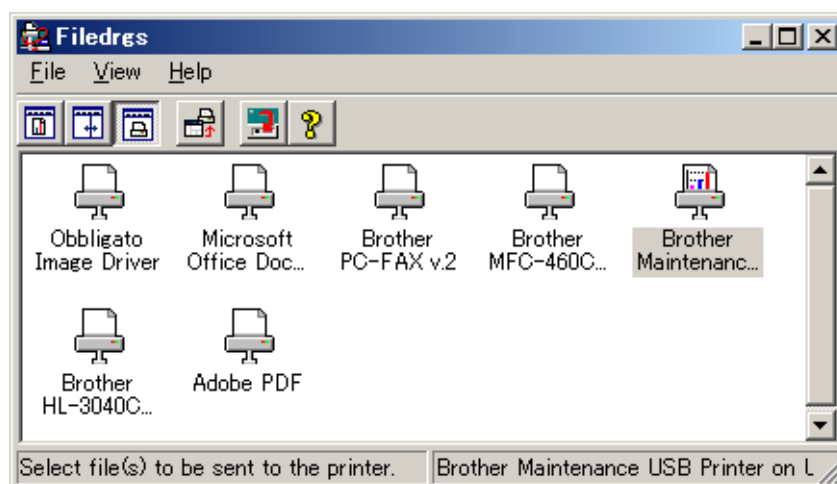
Check if the firmware written on the main PCB ASSY is the latest version or not. If it is the latest version, there is no need to write the firmware. If it is not, make sure to write the firmware to the main PCB ASSY in accordance with "1.1.2 Rewriting the firmware".

#### <How to check firmware version>

When the front cover is closed, press the [Go] button three times. And print the Printer Settings to check the firmware version.

### 1.1.2 Rewriting the firmware

- (1) Turn off your PC, and turn the power supply of the printer off.
- (2) Connect the PC and printer with the USB cable.
- (3) Open the front cover of the printer. Turn on the power supply while pressing the [Go] button, and then release the [Go] button after checking the lighting of the Toner/Drum/Error LED.
- (4) Check that all LEDs light off, and then press the [Go] button four times. Wait a few seconds and check that blink the Toner/Drum/Error LED once, and check that all LEDs light off. And then the printer shift to the "Rewrite firmware mode".
- (5) Turn on your PC.
- (6) Open the "hl2200" folder, and Double-click the "FILEDG32.EXE" to start. The following screen appears. Select the "Brother Maintenance USB Printer".



- (7) Drag the firmware (LZXXXX\_\$.bif) and drop it onto the Brother Maintenance USB Printer icon. The firmware files are sent to the printer and they are written into the flash ROM automatically.
- (8) The Ready LED and Error LED blink irregularly while the firmware being rewritten. The all LEDs light up when rewriting the firmware is completed. Be sure not to disconnect the USB cable or to turn off the power supply of the PC before the rewriting is completed.
- (9) When the front cover is closed, press the [Go] button three times. And print the "Printer Settings" to recheck the firmware version.
- (10) Turn the power supply of the printer off.

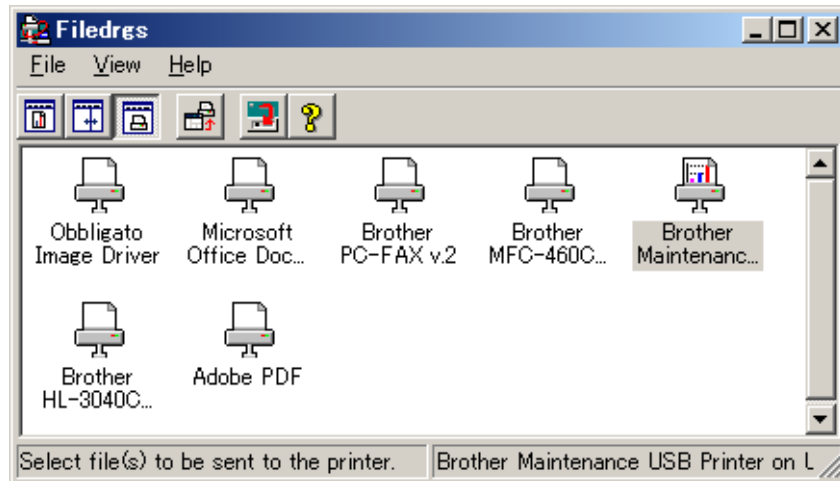
## 1.2 Setting the default paper size

### <Procedures>

#### Note :

- The maintenance driver must have been installed. (Refer to "APPENDIX 3 INSTALLING THE MAINTENANCE PRINTER DRIVER".)

- (1) Open the front cover, and turn the power supply of the printer on while pressing down the [Go] button. Make sure that the Toner/Drum/Error LED light up.
- (2) Release the [Go] button, and then make sure that all LEDs light off.
- (3) Press the [Go] button for over 2 seconds, and the Error LED light up. And then the printer goes into the PIT3 mode.
- (4) Connect the printer to PC with USB cable.
- (5) Double-click the "FILEDG32.EXE" on PC to start. The following screen appears. Select the "Brother Maintenance USB Printer".



- (6) Drag "DefaultPaperA4.pjl" (A4 size), "DefaultPaperLtr.pjl" (Letter size) or "DefaultPaperIsr.pjl" (A4 size, Israel font for Israel) and drop it onto the Brother Maintenance USB Printer icon.

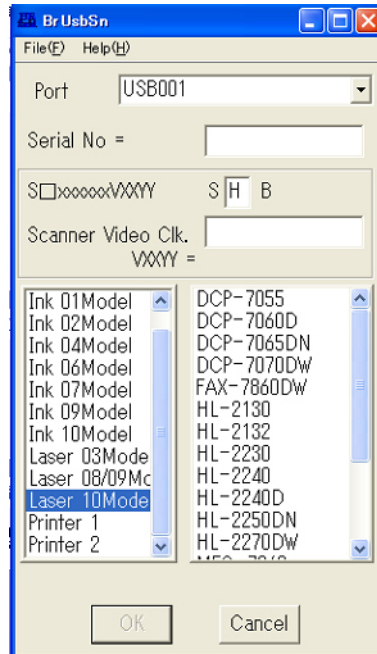
#### Note :

- The default setting of the new supply main PCB is A4 size.

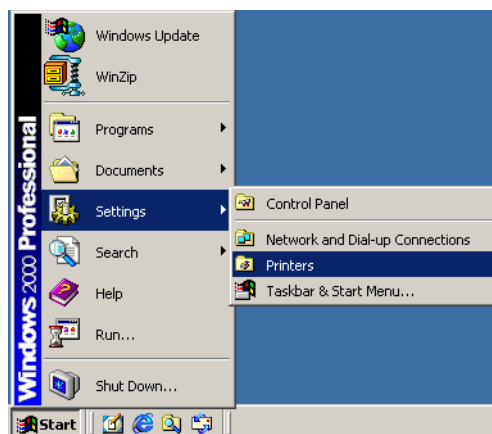
### 1.3 Setting the serial number

#### <Procedures>

- (1) Connect the PC and printer with the USB cable.
- (2) Double-click the brusbsn.exe file which has been copied in the "hl2200" folder to start.

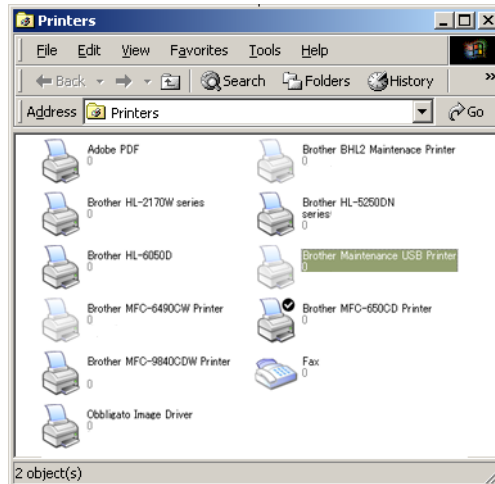


- (3) Click the Laser 10Model.
- (4) In Port on the brusbsn screen, select the port number assigned to the Brother Maintenance USB Printer. If the port number is unknown, follow steps below.
  - 1) Click Start | Settings | Printers.

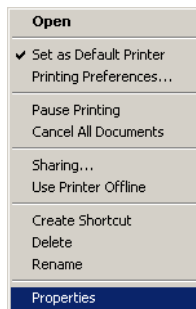


The Printers window appears as shown below.

- 2) Right-click the Brother Maintenance USB Printer icon.

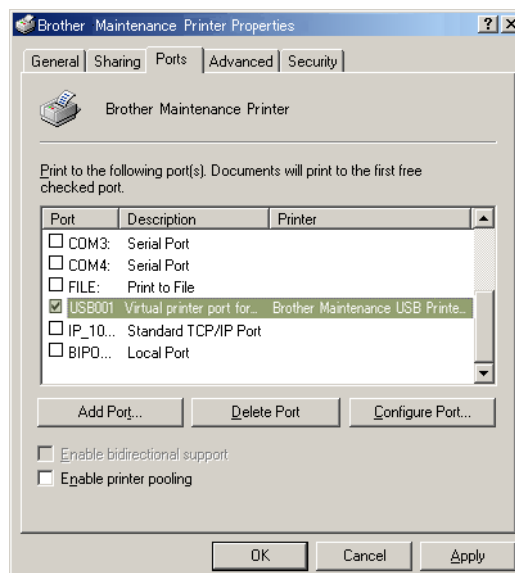


- 3) Click Properties.



The Brother Maintenance USB Printer Properties window appears as shown below.

- 4) Click the Ports tab.



In this example, the port number assigned to the Brother Maintenance USB Printer is USB001.

- (5) Enter the serial number (the fifteen digits) of the printer into the box on the "Serial No".
- (6) Click the **[OK]** button. The serial number is written in the printer.

### 1.4 Inputting the adjusted value of the laser unit

**Note:**

- When replace the laser unit, make sure to attach the laser serial label which is provided with the new laser unit to the laser plate.
- When input the adjusted value, make sure to refer to the laser serial label which is provided with the new laser unit.

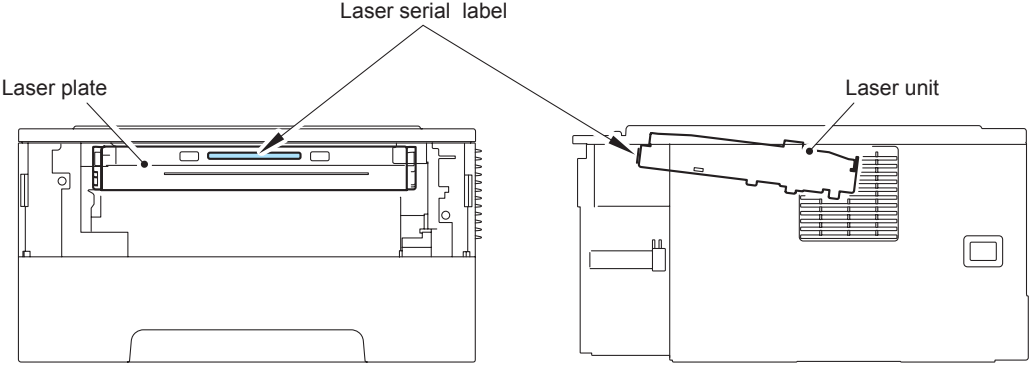
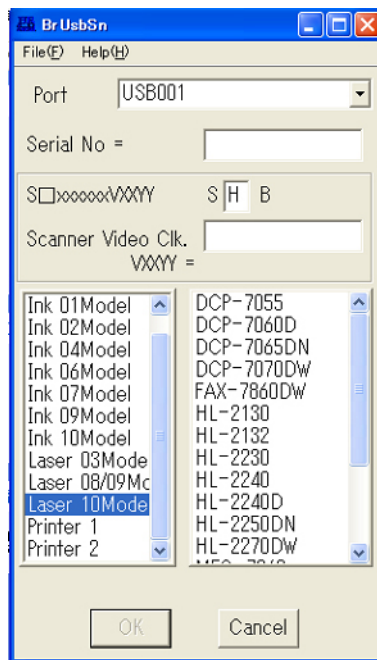
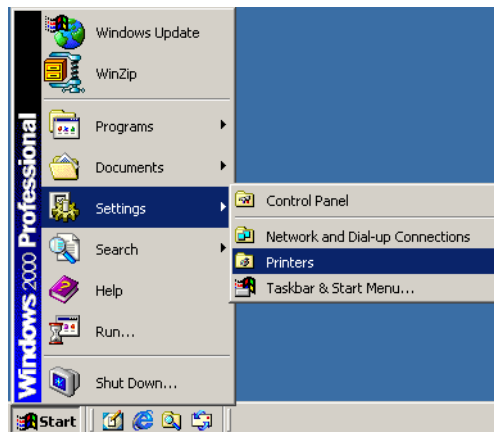


Fig. 4-1

- (1) Double-click the brusbsn.exe file to start.

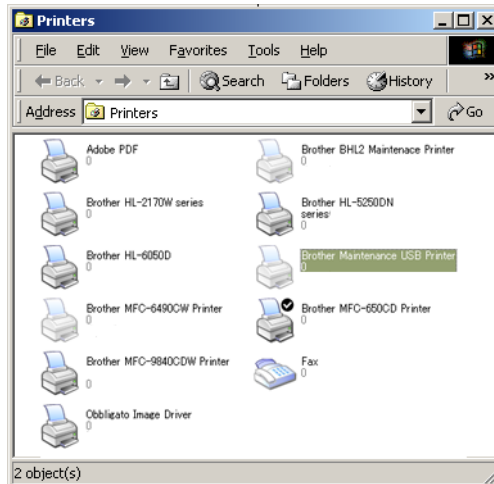


- (2) Click the Laser 10Model.
- (3) In Port on the brusbsn screen, select the port number assigned to the Brother Maintenance USB Printer. If the port number is unknown, follow steps below.
  - 1) Click Start | Settings | Printers.

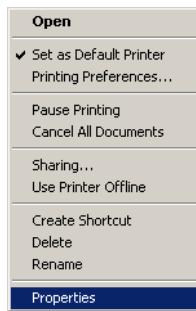


The Printers window appears as shown below.

- 2) Right-click the Brother Maintenance USB Printer icon.

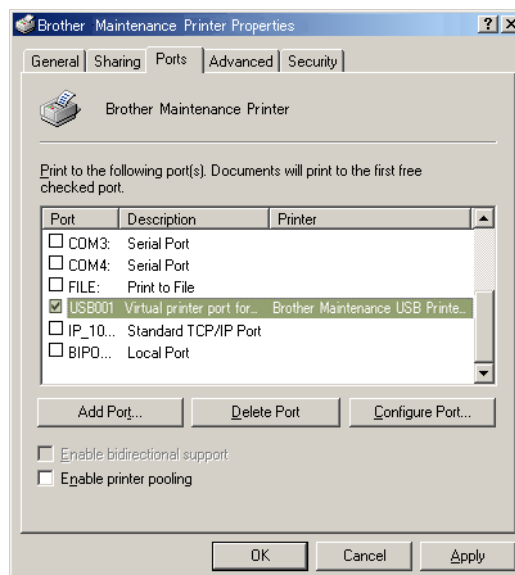


- 3) Click Properties.



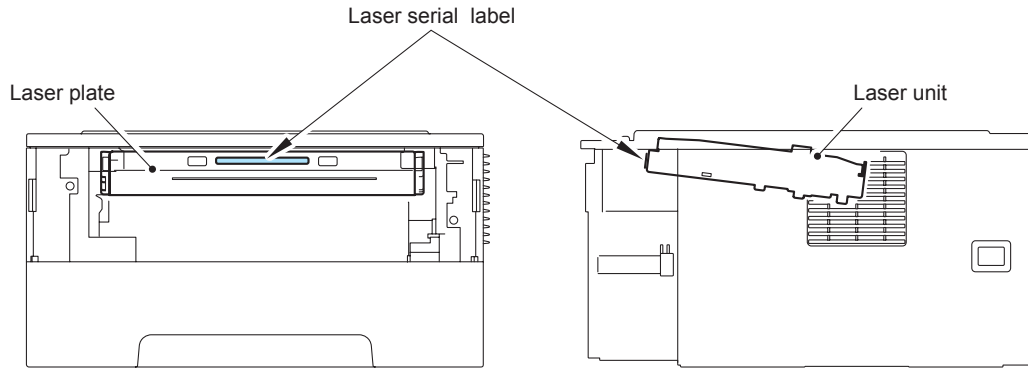
The Brother Maintenance USB Printer Properties window appears as shown below.

- 4) Click the Ports tab.



In this example, the port number assigned to the Brother Maintenance USB Printer is USB001.

- (4) Enter the serial number (second digit) shown on the laser serial label attached on the figure below into the box on the “S xxxxxxVXXYY”.
- (5) Enter the serial number (the last five digits) into the box on the “Scanner Video Clk.”.
- (6) Click the [OK] button. The corrected value of the laser unit is written in the printer.



**Fig. 4-2**

---

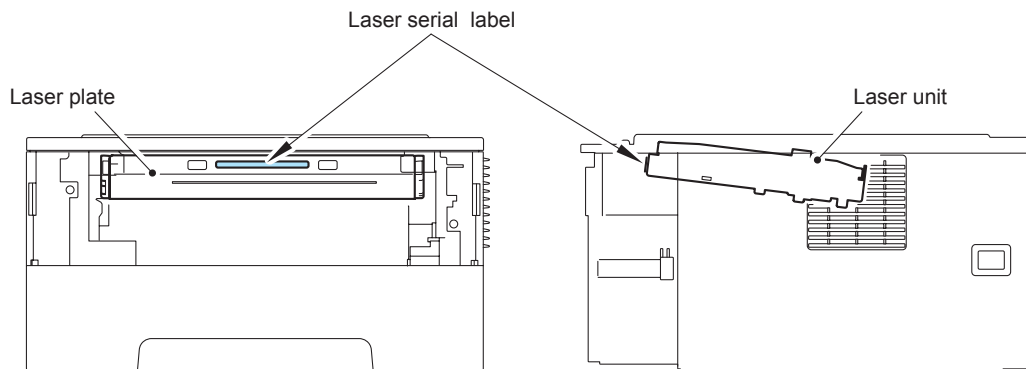
## 2. IF YOU REPLACE THE LASER UNIT

---

### 2.1 Inputting the adjusted value of the laser unit

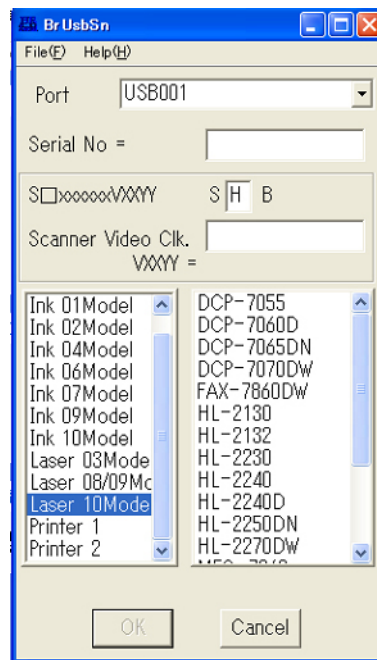
**Note:**

- When replace the laser unit, make sure to attach the laser serial label which is provided with the new laser unit to the laser plate.
- When input the adjusted value, make sure to refer to the laser serial label which is provided with the new laser unit.

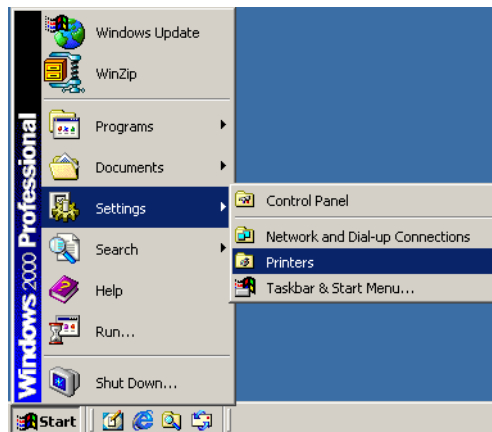


**Fig. 4-3**

- (1) Double-click the brusbsn.exe file to start.

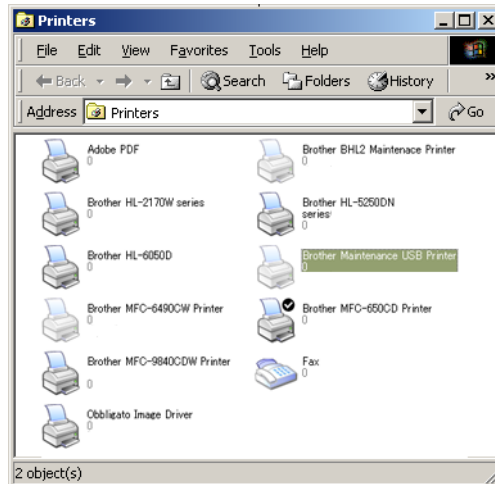


- (2) Click the Laser 10Model.
- (3) In Port on the brusbsn screen, select the port number assigned to the Brother Maintenance USB Printer. If the port number is unknown, follow steps below.
  - 1) Click Start | Settings | Printers.

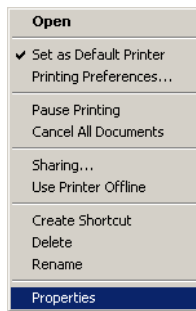


The Printers window appears as shown below.

- 2) Right-click the Brother Maintenance USB Printer icon.

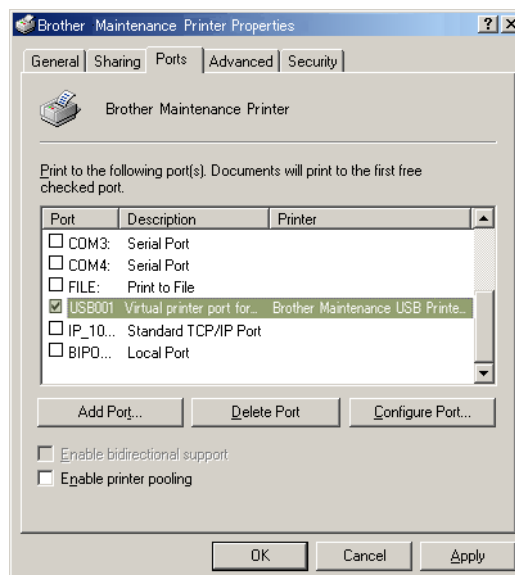


- 3) Click Properties.



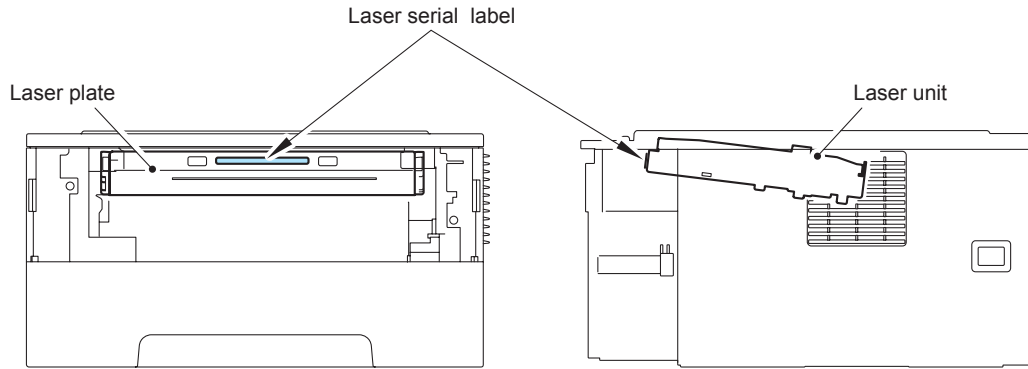
The Brother Maintenance USB Printer Properties window appears as shown below.

- 4) Click the Ports tab.



In this example, the port number assigned to the Brother Maintenance USB Printer is USB001.

- (4) Enter the serial number (second digit) shown on the laser serial label attached on the figure below into the box on the “S xxxxxxVXXYY”.
- (5) Enter the serial number (the last five digits) into the box on the “Scanner Video Clk.”.
- (6) Click the [OK] button. The corrected value of the laser unit is written in the printer.



**Fig. 4-4**

---

## 3. IF YOU REPLACE THE LOW VOLTAGE POWER SUPPLY PCB ASSY

---

### 3.1 Reset of Irregular Power Supply Detection Counter

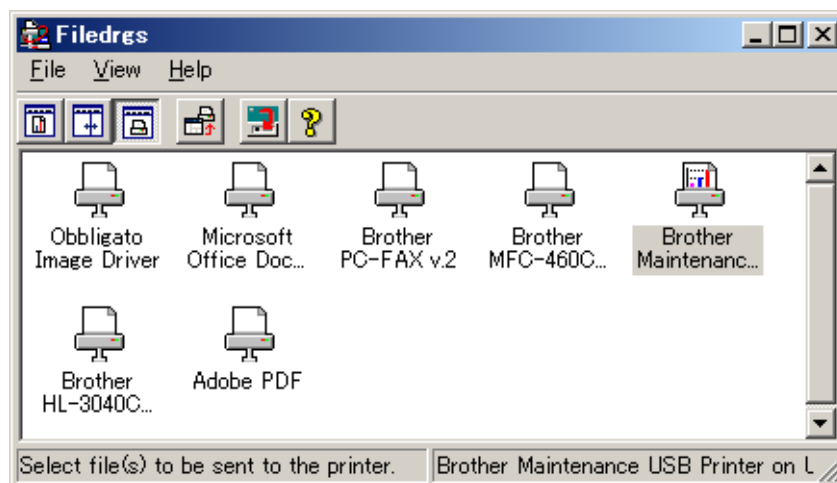
The irregular power supply detection counter is counted up when the printer detects irregular power supply. If the counter reaches to the limit, the printer shows the service error to replace the low voltage power supply PCB because it might be damaged by recursive irregular power supply.

In this case, if the same power supply is used, the same error may occur even when the low voltage power supply PCB ASSY is replaced. Ask the user to review the installation environment.

**Note :**

- The maintenance driver must have been installed. (Refer to "[APPENDIX 3 INSTALLING THE MAINTENANCE PRINTER DRIVER](#)".)

- (1) Open the front cover, and turn the power supply of the printer on while pressing down the [Go] button. Make sure that the Toner/Drum/Error LED light up.
- (2) Release the [Go] button, and then make sure that all LEDs light off.
- (3) Press the [Go] button for over 2 seconds, and the Error LED light up. And then the printer goes into the PIT3 mode.
- (4) Connect the printer to PC with USB cable.
- (5) Double-click the "FILEDYG32.EXE" on PC to start. The following screen appears. Select the "Brother Maintenance USB Printer".



- (6) Drag the SQWAVE.PJL and drop it onto the Brother Maintenance USB Printer icon.

---

## CHAPTER 5 SERVICE FUNCTIONS

---

The maintenance mode is exclusively designed for the purpose of checks, settings and adjustments using the buttons on the control panel or open/close of the front cover. You can perform operational checks of sensors, perform a print test, display the log information or error codes.

Various modes can be used if the power switch is set to ON while the [Go] button is held. There are two types of modes: End user-accessible maintenance mode and Service personnel-accessible maintenance mode. Three types of LED display are used to indicate that present state.

LED indication	Contents
Toner/Drum/Error LEDs light up at the same time	Show that transfer to the specified mode is completed.
Ready LED lights up	Show that the [Go] button is held when the mode or function is selected. Ready LED lights off if the [Go] button is not held.
All LEDs light for 1 second at the same time	Show that initialization or change of set values is completed.

---

## 1. MAINTENANCE MODE

---

### 1.1 How to Enter the End User-accessible Maintenance Mode

Basically, the maintenance-mode functions should be accessed by service personnel only. However, you can allow end users to access some of these under the guidance of service personnel (e.g., by telephone).

#### <Procedure>

- (1) Check that the front cover is closed.
- (2) Turn ON the power switch while holding down the [Go] button. Check that the Ready LED lights off after that the all LEDs light up, and then release the [Go] button.
- (3) Check that all LEDs light off, and then press the [Go] button depending on the necessary number of times.

### 1.2 How to Enter the Service Personnel-accessible Maintenance Mode

This mode function should be accessed by service personnel only for the checking and setting of the printer.

#### <Procedure>

- (1) Check that the front cover is opened.
- (2) Turn ON the power switch while holding down the [Go] button. Check that the Ready LED lights off after that the all LEDs light up, and then release the [Go] button.
- (3) Check that all LEDs light off, and then press the [Go] button depending on the necessary number of times.

#### **CAUTION :**

- Each mode starts 2 seconds after pressing the [Go] button.
- If the [Go] button is pressed, the Ready LED lights up. If the [Go] button is released, the LED lights off.

### 1.3 List of Maintenance Mode Functions

<How to enter the end user-accessible maintenance mode>

Front cover	Press the [Go] button when sifting the mode	Press the [Go] button when selecting the function	Function	Refer to:
Close	None	Once	1) Test Sample Page	5-5
		Twice	2) Print Fonts (Network model only) *2	5-5
		Three times	3) USB Number Return Value Setting	5-5
		Four times	4) Hex Dump Mode	5-5
		Five times	1) Test Sample Page	5-5
		Six times	5) Network Default Settings (Network Model only) *2	5-6
		Seven times	1) Test Sample Page	5-5
		Eight times	6) Factory Reset	5-6
		Nine times	1) Test Sample Page	5-5
		Ten times	7) Settings Reset	5-6
		Eleven times	1) Test Sample Page	5-5
		Twelve times	8) Engine Error Ignoring Mode	5-6
		Thirteen times	9) One Push Printing Recovery Function	5-6
More than fourteen times	1) Test Sample Page	5-5		

<How to enter the service personnel-accessible maintenance mode>

Front cover	Press the [Go] button when sifting the mode	Press the [Go] button when selecting the function	Function	Refer to:
Open	Once	Once	10) Operational Check of Sensors	5-7
		Twice	11) Continuous Grid Pattern Print Mode	5-8
		Three times	12) Fuser Unit Test Print	5-8
		Four times	13) EEPROM Value Dump Mode	5-8
		Five times	14) RAM Check	5-8
		Six times	15) Printer Quality Test Pattern Print	5-8
		Seven times	16) Duplex Setting (ON/OFF) *1	5-9
		Eight times	17) Paper Size Setting (A4/ Letter)	5-9
		Nine times	8) Engine Error Ignoring Mode	5-6
		More than ten times	Shift to ready state	

Front cover	Press the [Go] button when sifting the mode	Press the [Go] button when selecting the function	Function	Refer to:
Open	Twice	Once	<b>18) Printing for Maintenance</b>	<b>5-9</b>
		Twice	<b>19) Maintenance and Frame Pattern Print <sup>*3</sup></b>	<b>5-11</b>
		Three times	<b>20) Network Configuration Print (Network Model Only) <sup>*2</sup></b>	<b>5-11</b>
		Four times	<b>21) Sleep Mode Setting (ON/OFF)</b>	<b>5-11</b>
		Five times	<b>22) Develop Roller Counter Reset (For the starter toner cartridge)</b>	<b>5-11</b>
		Six times	<b>23) Develop Roller Counter Reset (For the standard toner cartridge)</b>	<b>5-11</b>
		Seven times	<b>24) Develop Roller Counter Reset (For the high-capacity toner cartridge)</b>	<b>5-11</b>
		Eight times	<b>25) USB Speed Fix Mode</b>	<b>5-11</b>
		Nine times	<b>26) Sleep Mode Indication (OFF/Dimmed)</b>	<b>5-11</b>
		More than ten times	Shift to ready state	
	Three times	Once	Factory use (not used)	
		Twice	Factory use (not used)	
		Three times	Factory use (not used)	
		Four times	Factory use (not used)	
		Five times	Factory use (not used)	
		Six times	Factory use (not used)	
		Seven times	Factory use (not used)	
		Eight times	Invalidity	
		Nine times	<b>27) Inspection Mode Unlock</b>	<b>5-12</b>
		Ten times	Factory use (not used)	
		Eleven times	Invalidity	
		Twelve times	Factory use (not used)	
		More than thirteen times	Shift to ready state	
		Four times	None	Factory use (not used)
	Five times	Once	Factory use (not used)	
	More than six times		Invalidity	
	More than 2 seconds		<b>28) PIT3 Mode</b>	<b>5-12</b>

**CAUTION :**

\*1 Start the test printing, when the function is performed with HL-2130/2220/2230/2240.

\*2 Start the test printing, when the function is performed with HL-2130/2220/2230/2240/2240D.

\*3 Start the Maintenance printing, when the function is performed with the models of the non-installing duplex.

## 1.4 Detailed Description of Maintenance-mode Functions

### ■ End user-accessible maintenance mode

#### 1) Test Sample Page

The printer prints a demo page. The printer returns to the ready state after printing.

#### 2) Print Fonts (Network model only)

The printer prints a list of the internal fonts. The printer returns to the ready state after printing.

#### 3) USB Number Return Value Setting

When the OS used the USB 2.0 FULL in Windows Vista<sup>®</sup>, do not recognize the ID of USB device depending on a combination of PC and USB device. To avoid this, the return value of ID can be locked to "0". It is switched to a set value opposite to a current set value, whenever switching.

The setting change of return value is distinguished by the LED display when the [Go] button is released.

The printer returns to the ready state after the setting is completed.

LED	Setting of return value
Toner LED lights for one second	Returns the serial number of the printer. (default) → Returns "0".
Drum LED lights for one second	Returns "0". → Return the serial number of the printer.

#### 4) Hex Dump Mode

This mode is printed as Hex data. without emulation processing the print data which received from the PC it is used for defectiveness analysis of the transmitted print data.

**5) Network Default Settings (Network Model only)**

**6) Factory Reset**

**7) Settings Reset**

Delete area of each reset is as follows.

Data item	Network default settings	Factory reset	Settings reset
Printer switch - Counter information			
Error history			
MAC address			
User switches (Items to be initialized when resetting to the factory default settings)		✓	✓
Function settings except user switches (Items except the factory default settings) - Languages - Reprint - Interfaces			✓
Macro/Font			✓
LAN area (Network settings)	✓		✓
PCL core area (Emulation settings)		✓	✓

**8) Engine Error Ignoring Mode**

Even when the engine error occurs and the main PCB ASSY exchange is required for recovery, the printer can be started, ignoring the engine error if this mode is used. EEPROM data can be obtained.

**9) One Push Printing Recovery Function**

The One Push Demo function is to implement demo printing by pressing the [Go] button, which is mainly used for sales promotion at the shop. It is disabled if printing from a computer even once.

This mode enables to recover One Push Printing. However, the design of printing is not demo page printing, but test printing after the recovery.

## ■ Service personnel-accessible maintenance mode

### 10) Operational Check of Sensors

This function allows you to check each of the sensors, electromagnetic clutch and motor.

In the operational check of sensors, the Ready LED blinks once when the state of a sensor or a switch is changed (from ON to OFF, or from OFF to ON). When the inspection is completed, the printer does not return to the ready state unless the power is turned off and on.

#### <Procedure>

#### ■ Operational check of sensors

Manually activate the sensors listed below, and verify that the Ready LED is lit. When the state is changed continuously, the Ready LED keeps blinking. When the verification of all the sensors is completed, the Toner LED becomes lit.

The sensors are as shown below;

- Front cover sensor
- New toner sensor
- Registration front sensor
- Registration rear sensor
- Eject sensor
- Back cover sensor/Duplex tray sensor
- Paper edge sensor (HL-2250DN/2270DW only)

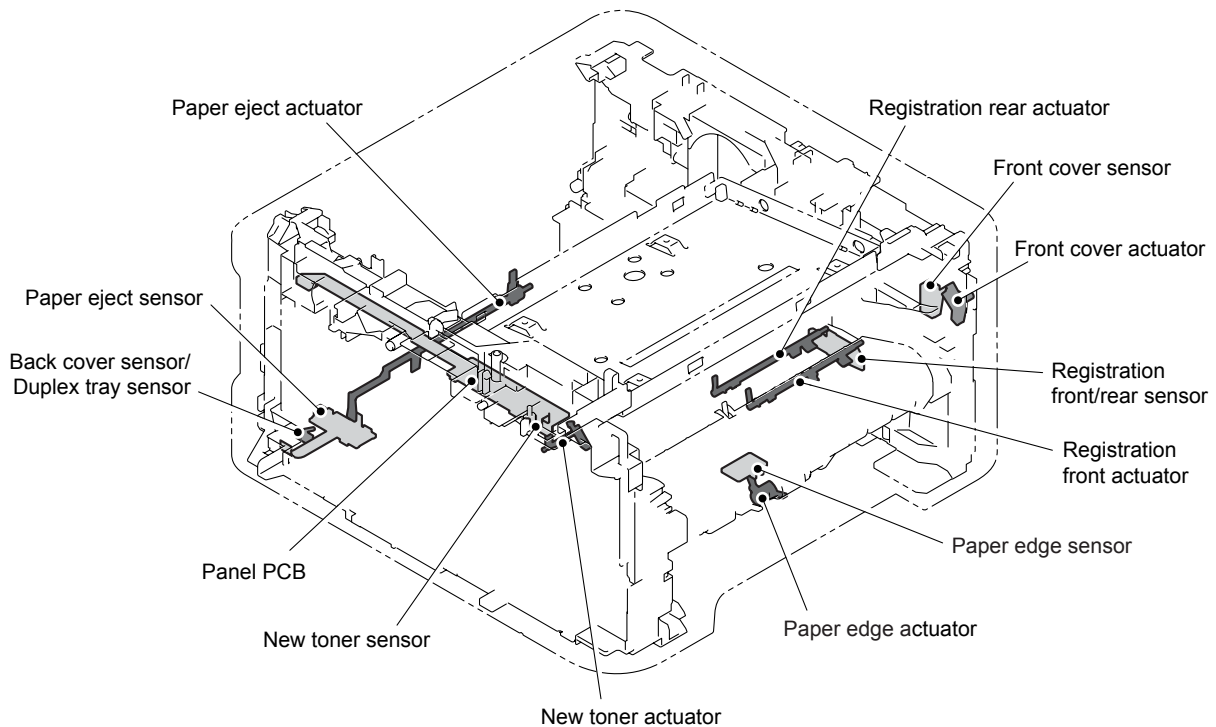


Fig. 5-1

## ■ Operational check of electromagnetic clutch

When detect that the state of registration front sensor is changed, the regist electromagnetic clutch is 200msON. When detect that the state of new toner sensor is changed, the pickup electromagnetic clutch is 200msON.

### CAUTION :

- When the operational check of electromagnetic clutch, the sounds is very low.

## ■ Operational check of motor

In the operational check of sensors, when the front cover is opened, close and open and close the fuser cover while pressing the [Go] button. Release the [Go] button, and close the front cover. and then the scanner motor is driven. The main motor is driven after two seconds from the scanner motor driving. When the open the front cover, the driving of the main motor and the scanner motor is stopped.

### 11) Continuous Grid Pattern Print Mode

This mode is to continuously print a grid pattern. The number of grid pattern prints is displayed at the same time. The printer does not go back to the ready state unless the power is turned off and on.

### 12) Fuser Unit Test Print

This is to print the following three patterns to check the fuser unit.

- Grid pattern
- Gray pattern
- Black pattern

When this operation is completed, the printer automatically return to the ready state.

### 13) EEPROM Value Dump Mode

This is to collectively print the present state of the EEPROM of all printers. When this operation is completed, the printer automatically return to the ready state.

### 14) RAM Check

This is to execute a stricter RAM check than a standard one. If the result turns out unaccepted, it considers an error, and all the LEDs blink. If it turns out accepted, the Ready LED blink once, and then Error LED blink eight times. The printer does not return to the ready state unless the power is turned off and on.

### 15) Printer Quality Test Pattern Print

This is to print four patterns to check the printer quality. The fourth pattern is continuous printing, and continue the printing until unlock the function by keeping the [Go] button pressed down.

## 16) Duplex Setting (ON/OFF)

Switch the ON/OFF of the duplex setting. Whenever you switch this mode, the setting is changed over from the present one to the other.

You can verify the setting change by LEDs when releasing the [Go] button. When the setting is completed, the printer return to the ready state.

LED	Setting of duplex
Toner LED and Drum LED light for one second	Duplex OFF → Duplex ON
Not light	Duplex ON → Duplex OFF

## 17) Paper Size Setting (A4/Letter)

Switch the ON/OFF of the paper size setting (A4/Letter) of the printer. Whenever you switch this mode, the setting is changed over from the present one to the other.

You can verify the setting change by LEDs when releasing the [Go] button. When the setting is completed, the printer return to the ready state.

LED	Setting of paper size
Toner LED and Drum LED light for one second	A4 → LETTER
Not light	LETTER → A4

## 18) Printing for Maintenance

This is to print a list of all maintenance information including printer coverage information. (There is not the development of each national language, and only English.)

Display terms is as follows.

Series Name	Model name of printer
Serial Number	Serial number of printer
Count. Rom Version	Rom version of printer
Device Status	Page Count, Drum Count, Average Coverage The maximum count for each item is 1 million times.
Drum Information	Estimated Pages Remaining, % of Life Remaining.
Total Pages Printed <sup>*1</sup>	Previously Used Toner, Current Toner. The maximum count for each item is 1 million times. % of Toner Life Remaining.
Total Pages Printed	Total Pages Printed (Tray 1, Manual Feed and Duplex Tray). The maximum count for each item is 1 million times. The information above is not cleared when replacing the PF kit.
Total Pages Printed	The number of A4/Letter, Legal/Folio, B5/Executive, Envelope, A5 and other paper types used. The maximum count for each item is 1 million times.
Total Pages Printed	The number of Plain/Thin/Recycled, Thick/Thicker/Bond, Envelopes/Env. Tick/Env. Thin, Label and Hagaki types used. The maximum count for each item is 1 million times.
Total Paper Jams	The number of paper jam occurrence in each of the Tray1, Inside, Rear and DX Tray. The paper jam occurs when the printer is turned ON is not counted.

Error History	The error history including the latest 10 errors and the number of pages when these errors occur are indicated. However, the Cover Open error, No Paper and Manual Feed is excluded. *2
Replace Count	The number of replacement of drum unit and toner cartridge. The maximum count for each item is 255 times.
Develop Roller Count *1	The rotation number of develop roller after replacing the toner cartridge.
Developing Bias *1	Developing Bias of now
Power On Time *1	Power ON time of printer (including the sleep)
Power On Count *1	Power ON count of printer

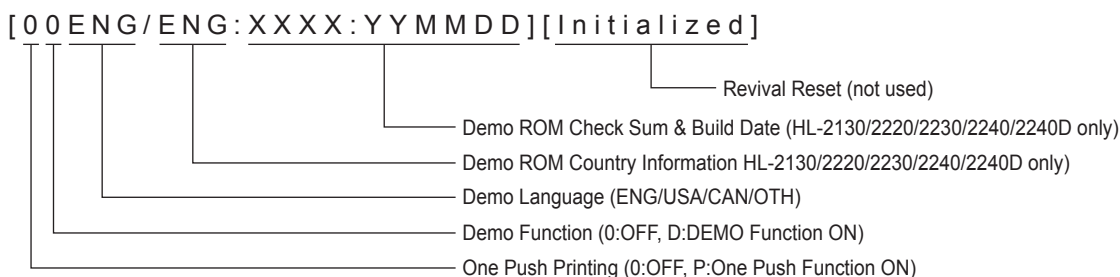
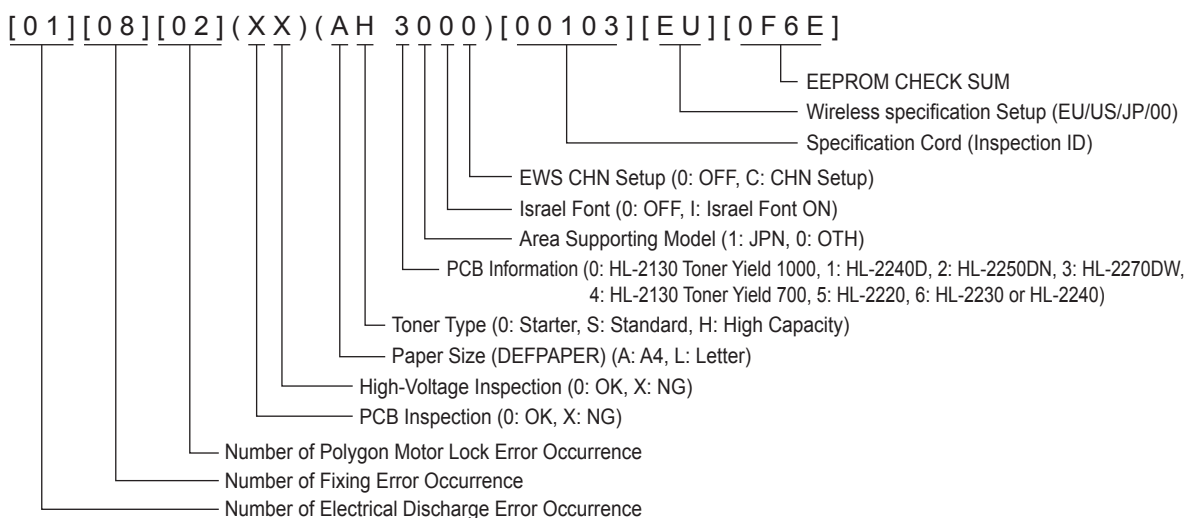
\*1 Display only in Maintenance information.

\*2 A period is attached before Page of the printing number of sheets of a jam error indication, when the power supply is switched on and jam has already happened and a jam generated when the front cover is opened and closed during feed of paper.

A period is attached to the Replace Toner indication in the time of Continue Mode at the end of the error message.

**CAUTION :**

- Some margin of error must be taken into consideration because coverage for the printable area of A4-size paper is calculated using printing image signals.



### 19) Maintenance and Frame Pattern Print

Page 1: Print the Maintenance printing. Page 2: Print the specification frame pattern printing with duplex printing. When set the duplex to OFF with “16) Duplex Setting (ON/OFF)”, the duplex printing is printed.

### 20) Network Configuration Print (Network Model Only)

Print the various network settings information of the printer.

### 21) Sleep Mode Setting (ON/OFF)

Switch the ON/OFF of the sleep function of the printer. Whenever you switch this mode, all LEDs light for one second and the setting is changed over from the present one to the other. When the setting is completed, the printer return to the ready state.

### 22) Develop Roller Counter Reset (For the starter toner cartridge)

### 23) Develop Roller Counter Reset (For the standard toner cartridge)

### 24) Develop Roller Counter Reset (For the high-capacity toner cartridge)

Since print density is likely to become darker as toner is getting older, the developing bias is lowered by degrees according to the number of prints so that an almost fixed density can be maintained from the start of the use of brand-new toner to the end of it. (The value of the developing bias is printed on the Maintenance sheet.) The developing bias is a parameter which depends on the toner cartridge, so it needs to be reset when the toner cartridge is replaced. (Usually, it is reset automatically.) At that time, the develop roller counter reading is also reset. This mode is to enable to execute these operations (equivalent to those done when the toner cartridge is replaced) manually from the service mode.

### 25) USB Speed Fix Mode

Switch the setting of USB FULL Fixing/Automatic switching (High/FULL). Whenever you switch this mode, the setting is changed over from the present one to the other. You can verify the setting change by LEDs when releasing the [Go] button. When the setting is completed, the printer return to the ready state.

LED	Setting of FULL Fixing/Automatic switching (High/FULL)
Toner LED lights for one second	Automatic switching (default) → FULL fixing
Drum LED lights for one second	FULL fixing → Automatic switching

### 26) Sleep Mode Indication (OFF/Dimmed)

This is to select whether the Ready LED is turned off completely or lit in green with low light intensity during the Sleep mode. Whenever you switch this mode, the setting is changed over from the present one to the other.

You can verify the setting change by LEDs when releasing the [Go] button. When the setting is completed, the printer return to the ready state.

LED	Setting of Ready LED intensity during the Sleep mode
Ready LED lights for one second with low light intensity	OFF → Low light intensity
Drum LED lights for one second with 100% light intensity in green	Low light intensity → OFF

## **27) Inspection Mode Unlock**

When find the entered inspection mode PCB in the market. Unlock the inspection mode with this function.

## **28) PIT3 Mode**

To identify terminals connected via USB interface, the PC requires the corresponding virtual USB devices to be implemented by driver. If you connect any number of the printer to your PC, therefore, the same number of virtual USB devices will be automatically configured on your PC. To prevent virtual USB devices from being configured limitlessly, enables your PC to identify terminals via single virtual USB device by entering the PIT3 mode.

## 2. PRINTER SETTINGS

### 2.1 Printout of Printer Settings

The printer prints "PRINTER SETTINGS". All pages have following items in common; Title, Model name, Serial number.

#### <Procedure>

- (1) The printer prints the "Printer Settings" by pressing the [Go] button three times when the printer is in the ready state.
- (2) Upon completion of printing, the printer returns to the ready state.

- HL-2130/2220/2230/2240/2240D

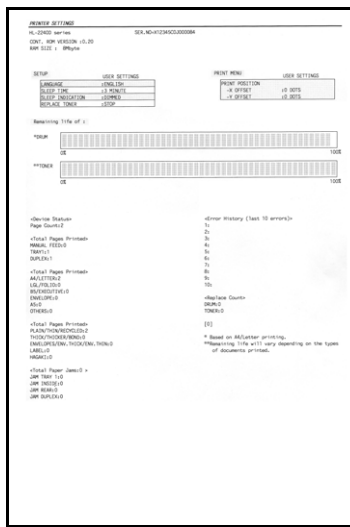


Fig. 5-2

- HL-2250DN/2270DW

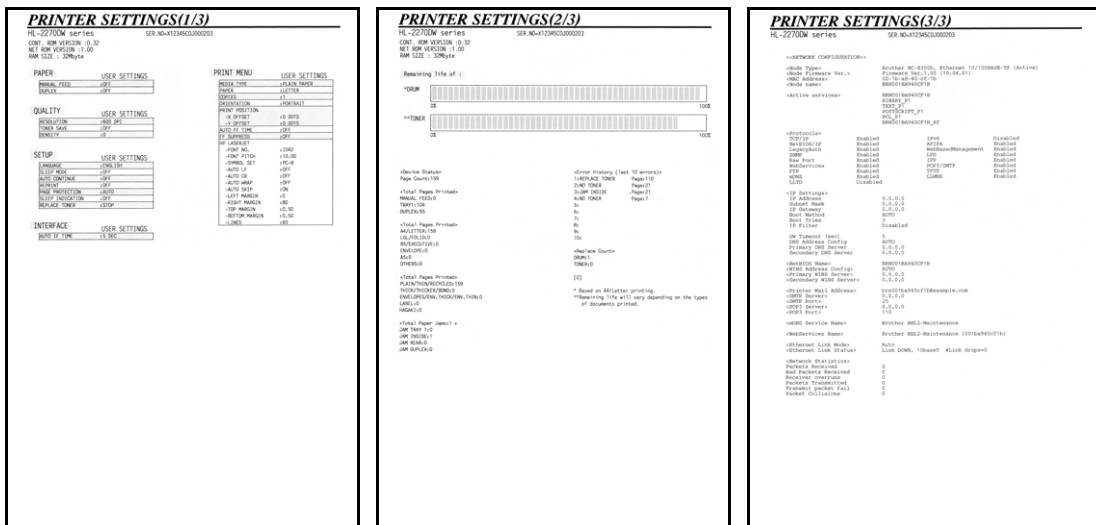


Fig. 5-3

## ■ Printer settings (Page 1)

This page includes various setting information of the printer. Each item is indicated when it fulfills the condition.

### CAUTION :

- HL-2130/2220/2230/2240/2240D include the maintenance information in Page 1.

## ■ Printer settings (Page 2)

This page includes the printer information and the maintenance information in the following order.

### (1) Printer information

This page includes the printer information and the maintenance information in the following order.

- 1) Main Controller Main ROM Version (Main controller firmware version)
- 2) NET ROM Version (Network model only)
- 3) RAM Size (MB)

### (2) Maintenance information

#### 1) Consumable information

The percentage of life remained over the total printable pages is indicated in numerical value and bar graph.

A sample indication (Drum unit) is as follows:

From the top left, the parts name, the number of printable pages remained, and the percentage of life remained are indicated. The column graph shows the percentage of the remaining life, and one block indicates 2%.

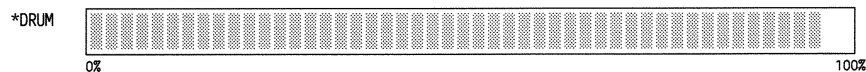


Fig. 5-4

The consumable parts indicated are as follows:

- Toner Cartridge
- Drum Unit

<Life of Toner Cartridge>

This product detects the remaining toner only by the dot count and the number of rotations of the develop roller. The function to detect by the light sensor is not installed. As this printer is not equipped with a toner sensor as conventional models are, it manages the level of remaining toner by dot count during printing and the number of rotations of the develop roller. Therefore printing may stop with the error message “Replace Toner” even though some toner remains. Even if “Replace Toner” is displayed on the printer, printing can be continued if the user chooses to change the mode to Continue Mode. In Continue Mode, however, the printing result when the toner runs out is not assured, meaning that the user shall be responsible for it. In addition to this, even when the mode is set to Continue Mode, printing stops when the number of rotations of the develop roller reaches the upper limit, and remains stopped until the toner cartridge is replaced to prevent any problems, such as toner leakage.

The life of the toner cartridge varies according to the average number of print pages per job. (See the table below.) The number of printable pages is larger when making continuous prints in one job because deterioration of the develop roller is low.

Relationship between average print page per 1 job and life of toner cartridges

26/27ppm model

Average print page (page/job)	1	2	3	...	Continuance
Cartridge life (Starter)	630	950	1200		2100
Cartridge life (Standard)	1080	1600	2000		3600
Cartridge life (High-capacity)	2340	3500	4300		7800

Page

24ppm model

Average print page (page/job)	1	2	3	...	Continuance
Cartridge life (Starter)	630	930	1100		2000
Cartridge life (Standard)	1080	1600	2000		3400
Cartridge life (High-capacity)	2340	3500	4200		7400

Page

20/21ppm model

Average print page (page/job)	1	2	3	...	Continuance
Cartridge life (Starter)	630	930	1100		2000
Cartridge life (Standard)	900	1300	1600		2900
Cartridge life (Standard) (HL-2220)	1080	1600	2000		3500
Cartridge life (High-capacity) (HL-2220)	2340	3500	4200		7600

Page

The develop roller also rotates for the warm-up operation when the power is turned ON and when the cover is opened or closed. Therefore, when these operations are frequently performed, the life of toner cartridges is shortened. (The table below shows the worst case in which the warm-up operation is performed when the power is turned ON.)

Life of the toner cartridges in the case that the power is turned OFF/ON for every print job  
26/27ppm model

Average print page (page/job)	1	2	3	...	Continuance
Cartridge life (Starter)	380	640	850		2100
Cartridge life (Standard)	650	1100	1500		3600
Cartridge life (High-capacity)	1400	2400	3100		7800

Page

24ppm model

Average print page (page/job)	1	2	3	...	Continuance
Cartridge life (Starter)	380	630	820		2000
Cartridge life (Standard)	640	1100	1400		3400
Cartridge life (High-capacity)	1400	2400	3000		7400

Page

20/21ppm model

Average print page (page/job)	1	2	3	...	Continuance
Cartridge life (Starter)	310	540	710		2000
Cartridge life (Standard)	440	770	1000		2900
Cartridge life (Standard) (HL-2220)	530	920	1200		3500
Cartridge life (High-capacity) (HL-2220)	1150	2000	2600		7600

Page

The life in Continue Mode is shown below. However, print may become light within the use upper limit value on the way.

Relationship between average print page per 1 job in Continue Mode and life of toner cartridges

26/27ppm model

Average print page (page/job)	1	2	3	...	Continuance
Cartridge life (Starter)	4500	6800	8300		15000
Cartridge life (Standard)	4500	6800	8300		15000
Cartridge life (High-capacity)	4500	6800	8300		15000

Page

24ppm model

Average print page (page/job)	1	2	3	...	Continuance
Cartridge life (Starter)	4500	6700	8100		14000
Cartridge life (Standard)	4500	6700	8100		14000
Cartridge life (High-capacity)	4500	6700	8100		14000

Page

20/21ppm model

Average print page (page/job)	1	2	3	...	Continuance
Cartridge life (Starter)	4500	6700	8100		15000
Cartridge life (Standard)	4500	6700	8100		15000
Cartridge life (High-capacity)	4500	6700	8100		15000

Page

Life of the toner cartridges in the case that the power is turned OFF/ON for every print job in Continue Mode

26/27ppm model

Average print page (page/job)	1	2	3	...	Continuance
Cartridge life (Starter)	2700	4600	6000		15000
Cartridge life (Standard)	2700	4600	6000		15000
Cartridge life (High-capacity)	2700	4600	6000		15000

Page

24ppm model

Average print page (page/job)	1	2	3	...	Continuance
Cartridge life (Starter)	2690	4500	5900		14000
Cartridge life (Standard)	2690	4500	5900		14000
Cartridge life (High-capacity)	2690	4500	5900		14000

Page

20/21ppm model

Average print page (page/job)	1	2	3	...	Continuance
Cartridge life (Starter)	2920	4900	6300		15000
Cartridge life (Standard)	2920	4900	6300		15000
Cartridge life (High-capacity)	2920	4900	6300		15000

Page

The numeral values provided in this page are as of June 2010. These values are subject to change without prior notice.

<Life of Drum Unit>

The drum unit life is based on the "drum counter" or the "number of drum rotations". Printing does not stop even when the drum unit reaches the end of life.

The drum counter is based on the total printed pages on each drum unit. This total printed pages should be reset every time you replace the drum unit with a new one. (Refer to <How to reset the drum counter> below.)

However, if the power switch is turned OFF/ON frequently or if you print few pages per one job, only the number of drum rotations increases. Then, the number of drum rotation exceeds the "drum counter" based on the total printed pages and the drum unit may reach the end of life.

Average print page per one job and life of drum unit

26/27ppm model

Average print page (page/job)	1	2	3	...	Continuance
Drum unit	12000	18000	22000		40000

Page

20/21ppm model, 24ppm model

Average print page (page/job)	1	2	3	...	Continuance
Drum unit	12000	18000	22000		39000

Page

Drum rotations are required for the warm-up operation when the power is turned ON or when the cover is opened or closed. Therefore, when these operations are frequently performed, the life of drum unit is shortened. (The table below shows the worst case in which the warm-up operation is performed when the power is turned ON.)

Life of the drum unit in the case that the power is turned OFF/ON for every print job

26/27ppm model

Average print page (page/job)	1	2	3	...	Continuance
Drum unit	7000	12000	16000		40000

Page

20/21ppm model, 24ppm model

Average print page (page/job)	1	2	3	...	Continuance
Drum unit	7000	12000	15000		39000

Page

The numeral values provided in this page are as of June 2010. These values are subject to change without prior notice.

<How to reset the drum counter>

- (1) Open the front cover, and press the [Go] button for over 4 seconds. Make sure that all LEDs light up.
- (2) Release the [Go] button, and then make sure that all LEDs light off.
- (3) Close the front cover, and press the [Go] button three times. Print the Printer Settings, and then check whether the drum counter is reset or not.

2) Counter information, history information

The counter and history information related to the following term are included.  
When it reaches the maximum count, each term is no longer counted.

Device Status	Page Count (The total number of printed pages). The maximum count is 1 million pages.
Total Pages Printed	The number of times that each of the Manual Feed, Tray1 and Duplex tray is used. The maximum count for each item is 1 million times. The information above is not cleared when replacing the PF kit.
Total Pages Printed	The number of A4/Letter, Legal/Folio, B5/Executive, Envelope, A5 and other paper types used. The maximum count for each item is 1 million times.
Total Pages Printed	The number of Plain/Thin/Recycled, Thick/Thicker/Bond, Envelopes/Env. Tick/Env. Thin, Label and Hagaki types used. The maximum count for each item is 1 million times.
Total Paper Jams	The number of paper jam occurrence in each of the Tray1, Inside, Rear and Duplex. The paper jam occurs when the printer is turned ON is not counted. The maximum count for each item is 65,535 times. Total number of jam occurrences is printed after "Total Paper Jams:."
Error History	The error history including the latest 10 errors and the number of pages when these errors occur are indicated. The errors such as Cover Open, No Paper and Manual Feed are not included.
Replace Count	The number of replacement of each of Drum Unit and Toner Cartridge. The maximum count for each item is 255 times.

■ **Printer settings (Page 3, Page 4)**

These pages include various network settings information of the printer.

HL-2250DN	Page3: Wired Network Information
HL-2270DW	LAN: Wired Enable setting = ON and WLAN Enable setting = ON Page3: Wired Network Information Page4: Wireless Network Information
	LAN: Wired Enable setting = ON and WLAN Enable setting = OFF Page3: Wired Network Information Page4: Not available
	LAN: Wired Enable setting = OFF and WLAN Enable setting = ON Page3: Wireless Network Information Page4: Not available
	LAN: Wired Enable setting = OFF and WLAN Enable setting = OFF Page3 and 4: Not available

---

## 3. OTHER SERVICE FUNCTIONS

---

### 3.1 Reprint Function

When there is no Receiving/Processing data in the printer, shift to the “Reprint Menu” by pressing [Go] button for four seconds. And reprint the last printed data in the interval before turning OFF after ON of the power supply last.

**CAUTION :**

- The reprint function is OFF by default. The long-pushing the [Go] button is invalid in the state of the Reprint is OFF.

**<Procedure>**

- (1) Keep the [Go] button pressed down in the state of the Reprint is ON, and release the [Go] button after lighting the Toner LED, Drum LED, Error LED and Ready LED in this order.
- (2) Light off the Ready LED, and then push the [Go] button only the number of necessary print number of documents within two seconds in the state of the Toner LED, Drum LED and Error LED is ON (Print copies setting mode in this state).
- (3) After pressing the [Go] button only the number of necessary print number of documents in the procedure (2), press the [Go] button within two seconds again. and add the number of times of pushing and perform the Reprint. (The maximum printing is 999 times)
- (4) When the printing is completed, the printer return to the ready state.

**CAUTION :**

- Perform the Repeat printing only one page, when there is no pressing [Go] button within two seconds after shifting the “print copies setting mode”.

### 3.2 Job Cancel Function

When there is no Receiving/Processing data in the printer, perform the Job Cancel by pressing [Go] button for four seconds. Also, press the [Go] button during the Job Cancel, and start the multiple Job Cancel.

**<Procedure>**

- (1) Keep the [Go] button pressed down in the ready state, and release the [Go] button after lighting the Toner LED, Drum LED, Error LED and Ready LED in this order. Start the Job Cancel of the Receiving/Processing data. Blink the Error LED and Ready LED alternately during the Job Cancel.
- (2) Press the [Go] button once during processing the Cancel in the procedure (1) to cancel the various Receiving/Processing data.

### 3.3 Wireless LAN setting (Wireless Network Model only)

When the printer is in the ready state, you can switch to the Effective/Invalidity of the wireless LAN setting by pressing the [Go] button for ten seconds.

#### <Procedure>

- (1) Keep the [Go] button pressed down in the ready state, and check the lighting of the Toner LED, Drum LED, Error LED and Ready LED in this order. Keep the [Go] button pressed down, and Start the printing of the wireless network information after lighting off the Toner LED, Drum LED and Error LED. And switch to the Effective/Invalidity of the wireless LAN setting
- (2) Release the [Go] button.
- (3) It is switched to a set value opposite to a current set value, whenever switching. and then the wireless network information (Network Configuration) printing is implement. Check that which of wireless LAN or wired LAN became effective. Judge by the Active or Inactive from “Node Type” which is mentioned in “Network Configuration” of “Printer Settings”.

#### CAUTION :

- When keep the [Go] button pressed down in the procedure (2), Start the lighting of the Toner LED, Drum LED, Error LED and Ready LED in this order. And switch to a set value opposite. Then, the setting is not changed even if it continues pushing the [Go] button.

### 3.4 Wireless Connecting Diagnostic Report Print (Wireless Network Model only)

When press the [Go] button five times in the ready state, print the Wireless Connecting Diagnostic Report Print (WLAN report).

```
<< WLAN report >>
*****
* Connection : Failed (Error : EB-01)
*****
* Connection Failed.
* For details, please refer Troubleshooting in Quick Setup Guide.
*****

*** Solution ***
The WLAN setting is not activated, turn the WLAN setting to ON
(see Troubleshooting in Quick Setup Guide).
- If a LAN cable is connected to your machine, disconnect it and
  turn the WLAN setting of your machine to ON.

<Configuration>
Network Name (SSID)          SETUP
Hardware Address (MAC)      01:21:58:10:01:45
Communication Mode          Ad-Hoc
Authentication Type         Open System
Encryption                  NONE
Network Channel             -
```

Fig. 5-5

### 3.5 Continue Mode/Stop Mode settings of Toner Cartridge

You can switched to the “Continue mode” that usable toner cartridge after displaying the “Replace Toner” in the LED.

#### <Procedure>

- (1) Press the [Go] button seven times in the ready state. The Continue mode and Stop mode settings of the toner cartridge are switched. It is switched to a set value opposite to a current set value, whenever switching. You can verify the setting change by LEDs when releasing the [Go] button. When the setting is completed, the printer return to the ready state.

LED	Settings of Continue mode/Stop mode
All LEDs light two times	Stop mode → Continue mode
All LEDs light once	Continue mode → Stop mode

#### Note:

- Printing is not guaranteed in the continue mode.
- If the toner cartridge is replaced, the printer returns to the default setting.

### 3.6 Drum Cleaning Function

#### <Procedure>

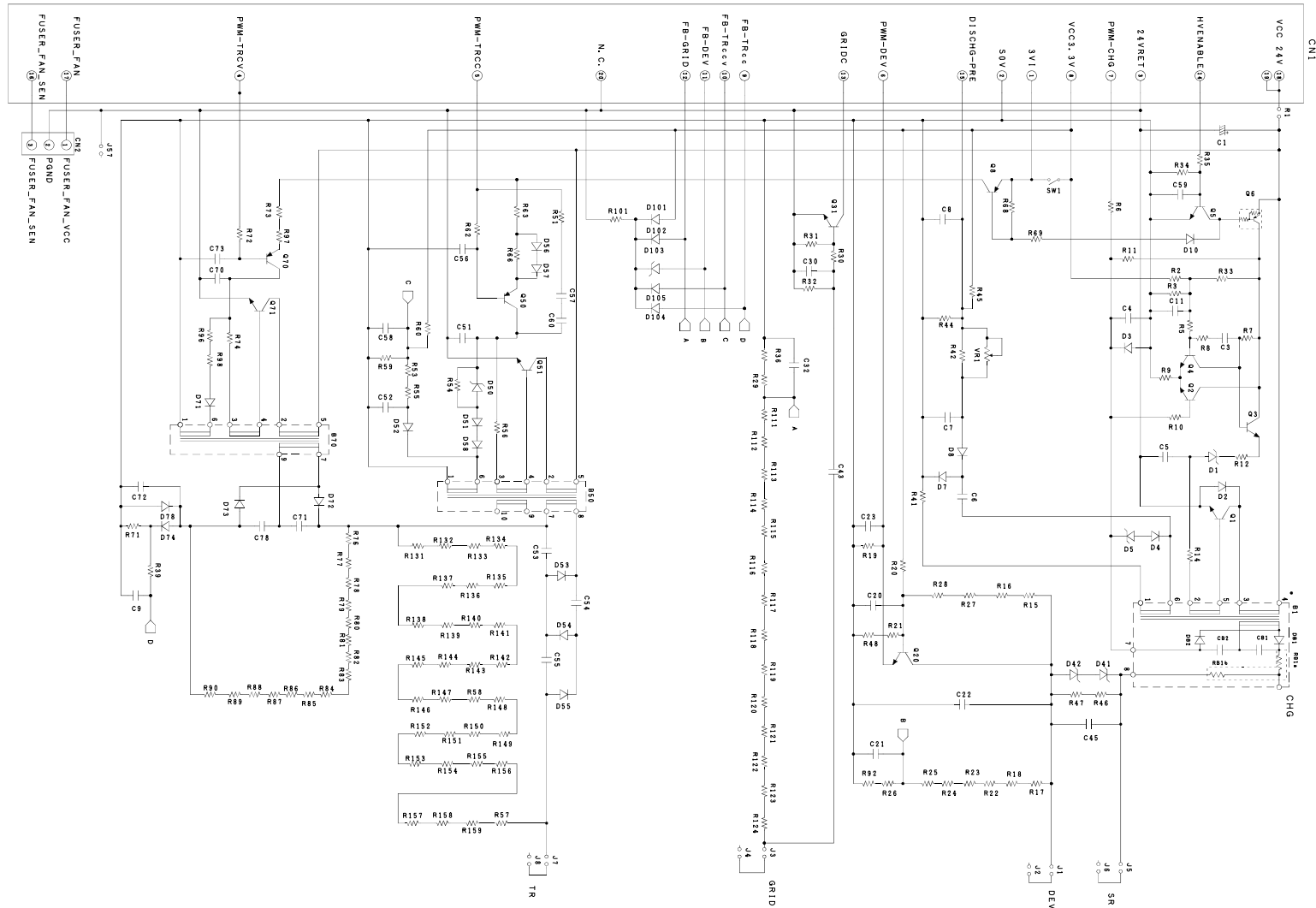
- (1) Check that the front cover and Back cover are opened in the ready state, and press the [Go] button five times. Shift to the “Drum Cleaning mode”.
- (2) Close the front cover. Install the plain paper in the manual feed slot to start the paper feeding, and perform the “Drum Cleaning”. When the cleaning is completed, the printer automatically return to the ready state.

#### CAUTION :

- When the error of jam during the Drum Cleaning, Drum Cleaning mode is canceled automatically and becomes the error display.

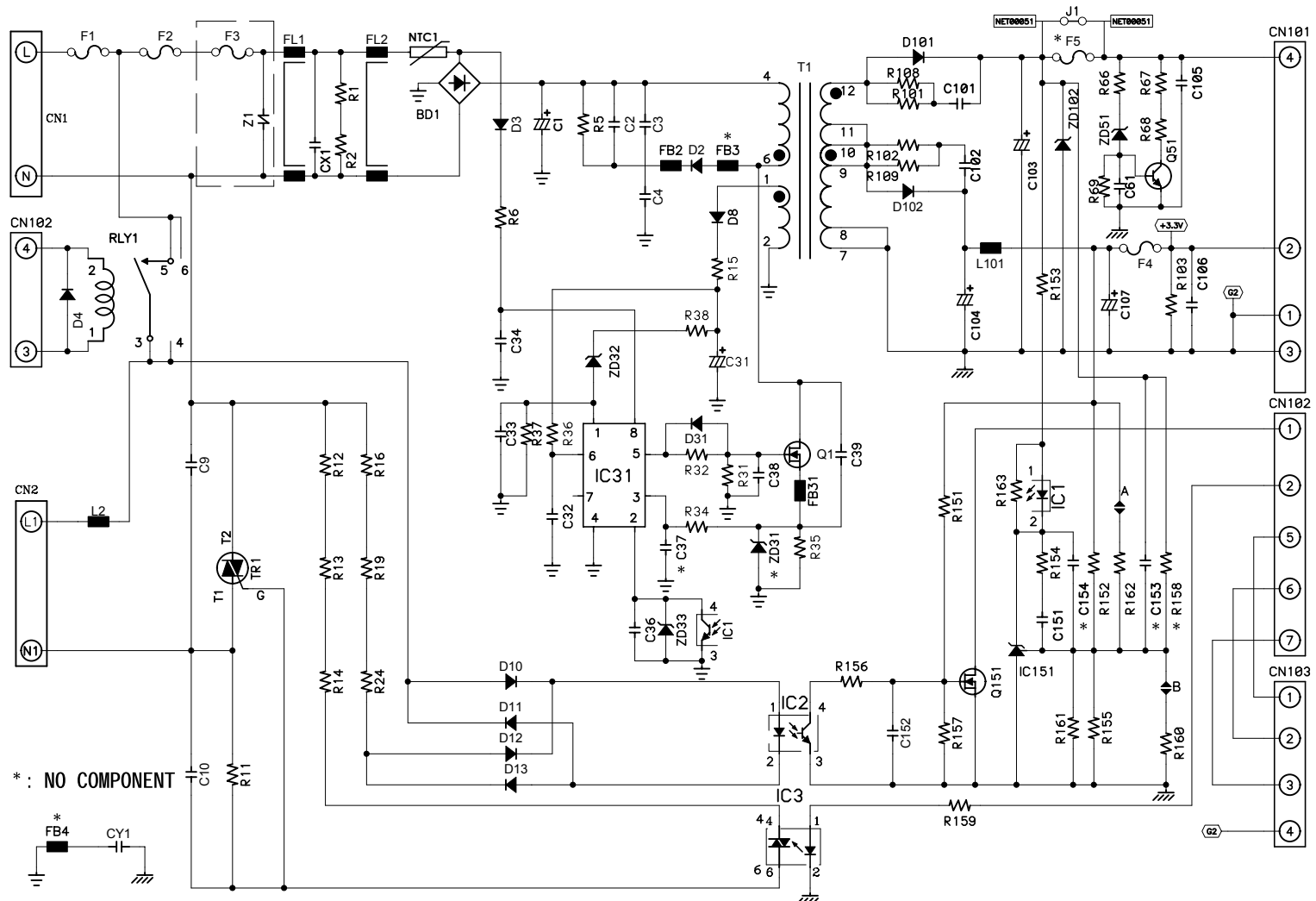
# CHAPTER 6 CIRCUIT DIAGRAMS, WIRING DIAGRAM

## High Voltage Power Supply PCB Circuit Diagram (MURATA)



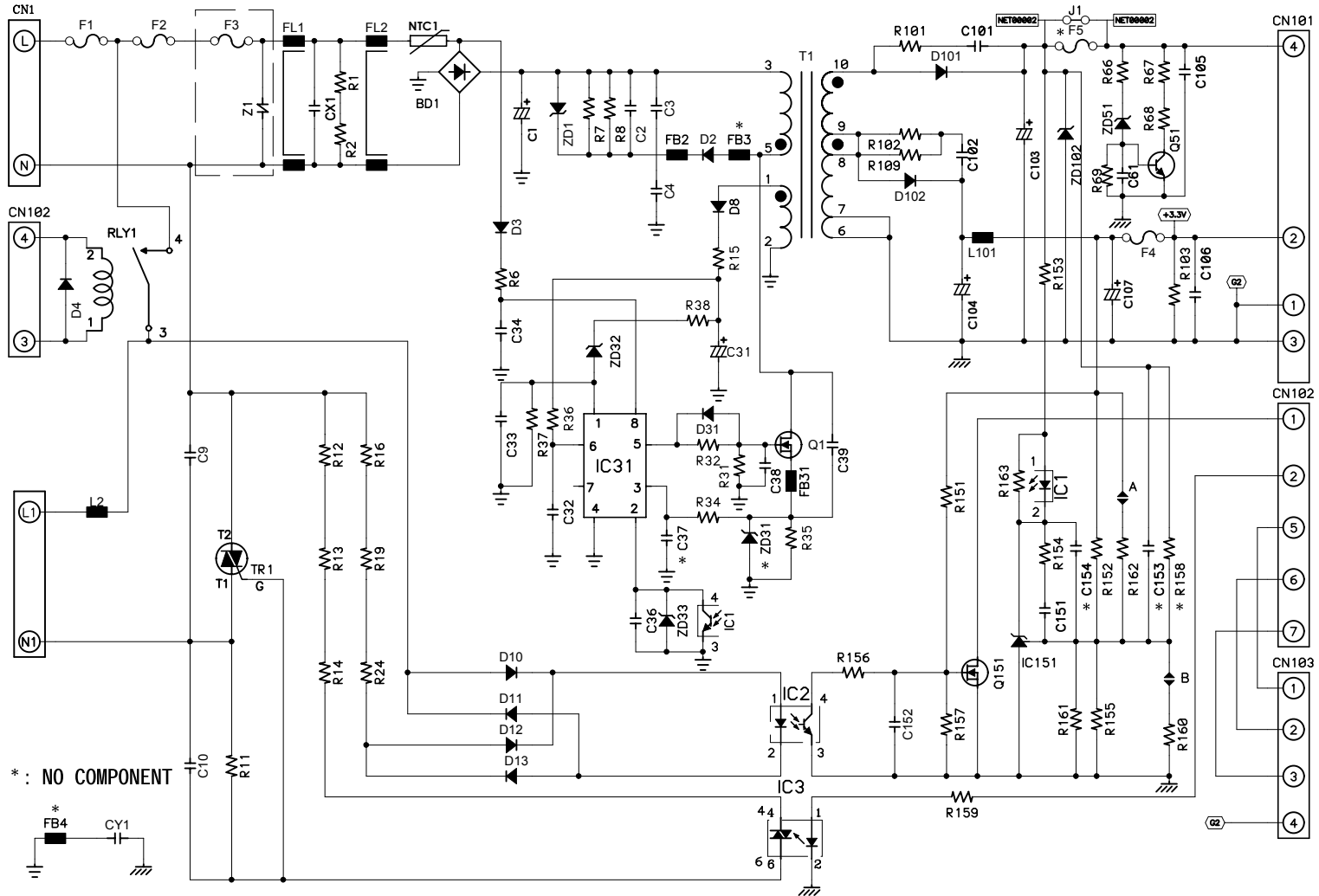


■ Low Voltage Power Supply PCB Circuit Diagram (115V) EDPS-52AF A (Delta)

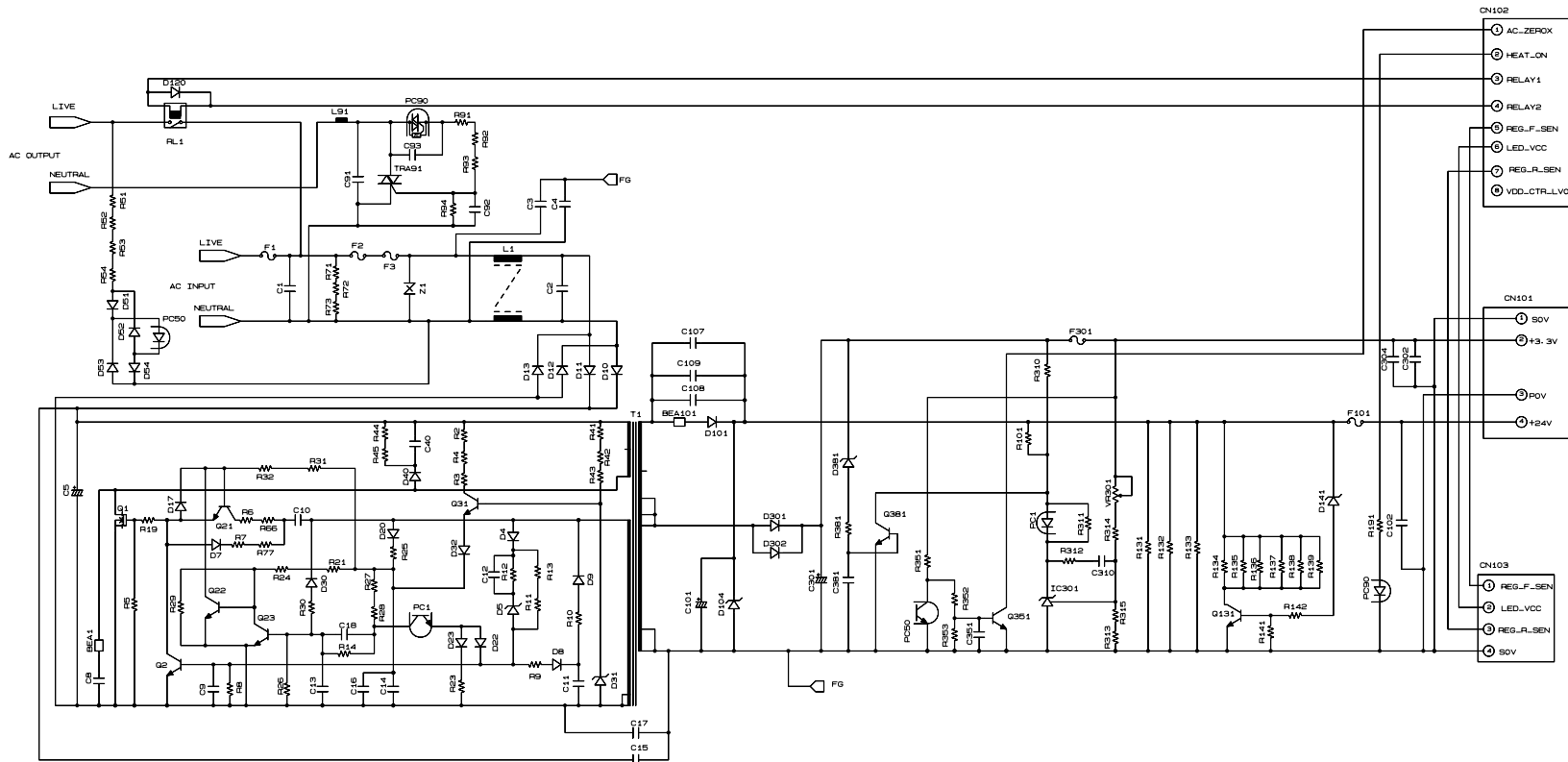




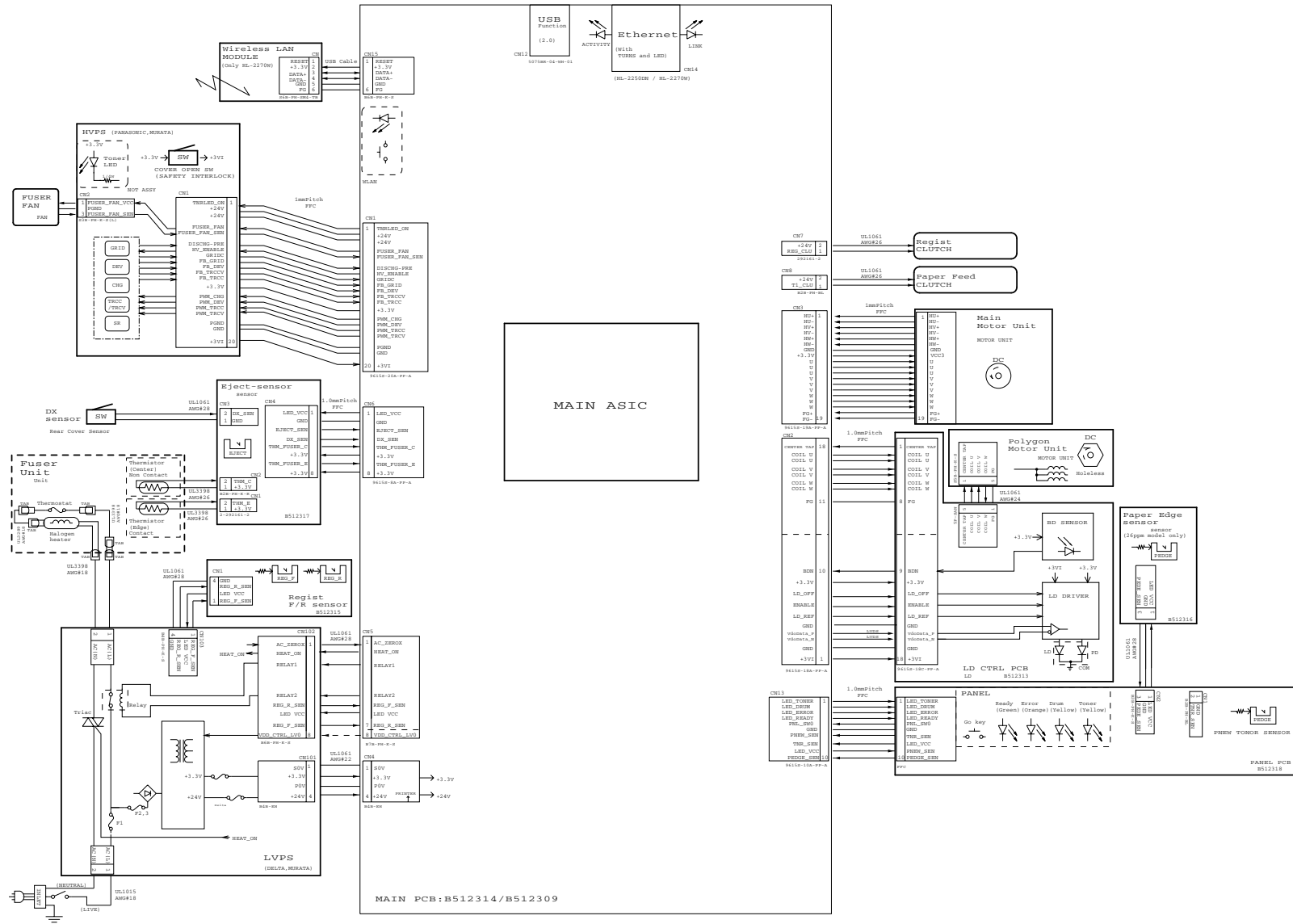
■ Low Voltage Power Supply PCB Circuit Diagram (230V) EDPS-52BF A (Delta)



■ Low Voltage Power Supply PCB Circuit Diagram (230V) MPW3053 (MURATA)



# ■ Wiring Diagram



---

## **CHAPTER 7 PERIODICAL MAINTENANCE**

---

### **1. PERIODICAL REPLACEMENT PARTS**

---

There are no parts to be replaced periodically.

## APPENDIX 1 SERIAL NUMBERING SYSTEM

Refer to the information below for the meaning of the serial number and property codes and the location of each label.

### ■ Serial number labels for the printer itself

#### <How to Read>

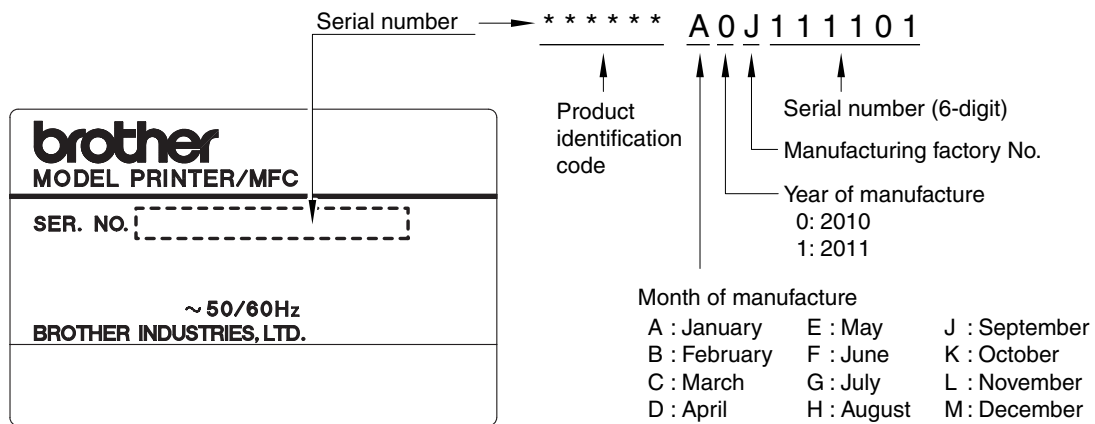


Fig. App. 1-1

#### <Location>

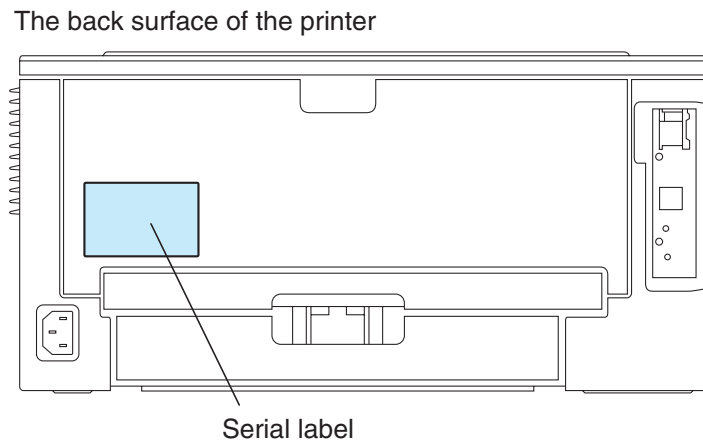


Fig. App. 1-2

---

## **APPENDIX 2 DELETION OF USER SETTING INFORMATION**

---

The user setting information of the printer is recorded in the main PCB. Reset the printer back to its default printer settings in the following procedures.

- (1) Close the front cover, and turn the power supply of the printer on while pressing down the [Go] button. Make sure that all LEDs light up.
- (2) Release the [Go] button, and then make sure that all LEDs light off.
- (3) Press the [Go] button ten times.
- (4) When this operation is completed, the printer automatically return to the ready state.

---

## APPENDIX 3 INSTALLING THE MAINTENANCE PRINTER DRIVER

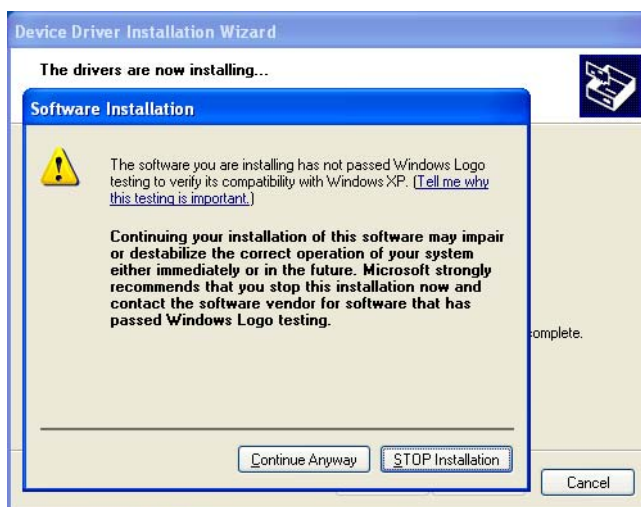
---

To identify terminals connected via USB interface, the PC requires the corresponding virtual USB devices to be implemented by driver. If you connect any number of the printer to your PC, therefore, the same number of virtual USB devices will be automatically configured on your PC. To prevent virtual USB devices from being configured limitlessly, use the unique driver installation procedure described below that enables your PC to identify terminals via single virtual USB device.

- (1) Check that the power switch of the printer is turned off. Disconnect the USB cable that connects the printer with PC.
- (2) Turn on your PC.
- (3) Open the front cover, and turn the power supply of the printer on while holding down the [Go] button. Make sure that the Toner/Drum/Error LED lights up.
- (4) Release the [Go] button, and then make sure that all LEDs are off.
- (5) Press the [Go] button for the 2 seconds, and the Error LED lights up.
- (6) Click the “maintenance.exe” of the Printer Maintenance Driver which has been copied in the “hl2200” folder to start.
- (7) The following screen appears, indicating the detection of device installation wizard. Click Next to proceed.



- (8) Alert warning message of WHQL appears three times. Click Continue Anyway to proceed.

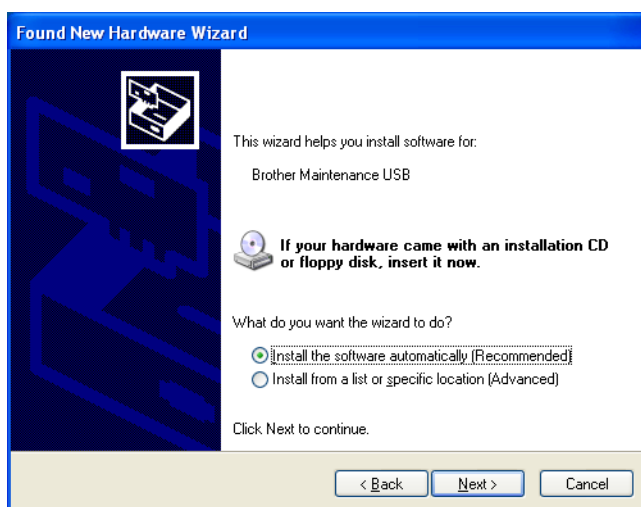


- (9) If the device driver is successfully installed, the following message screen appears. Click Finish to return.

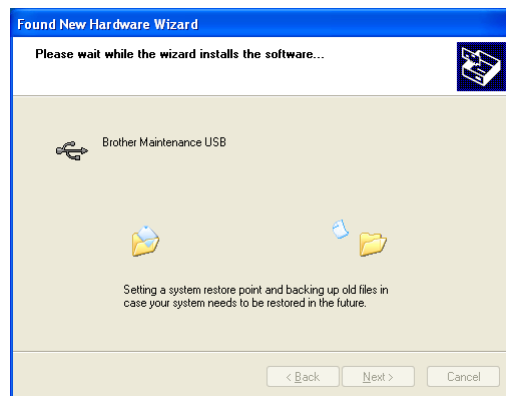
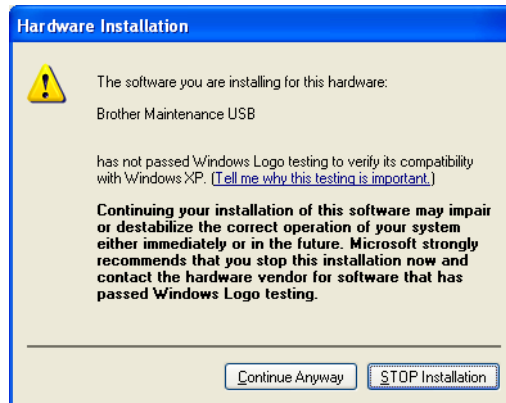


- (10) Connect the printer to your PC using the USB cable.

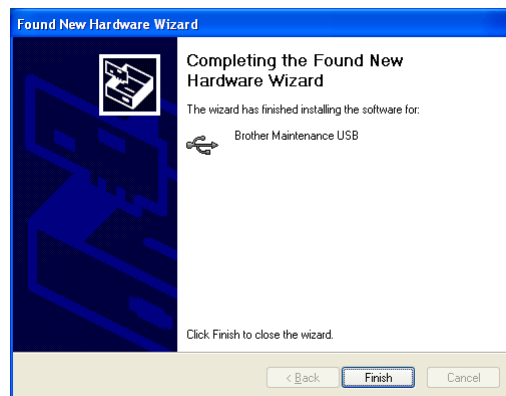
- (11) Select "Install the software automatically (Recommended)" and click Next.



(12) Alert warning message of WHQL appears. Click Continue Anyway to proceed.



(13) If the Brother Maintenance USB Printer driver is successfully installed, the following message screen appears. Click Finish to return.



## APPENDIX 4 HOW TO MAKE PROTECTIVE MATERIAL OF DRUM UNIT

There are old and new parts for Protective material and Paper strip of drum unit respectively. Each Protective material and Paper strip is compatible.

### Protective material

#### ■ Old type



#### ■ New type

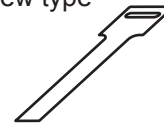


### Paper strip

#### ■ Old type



#### ■ New type

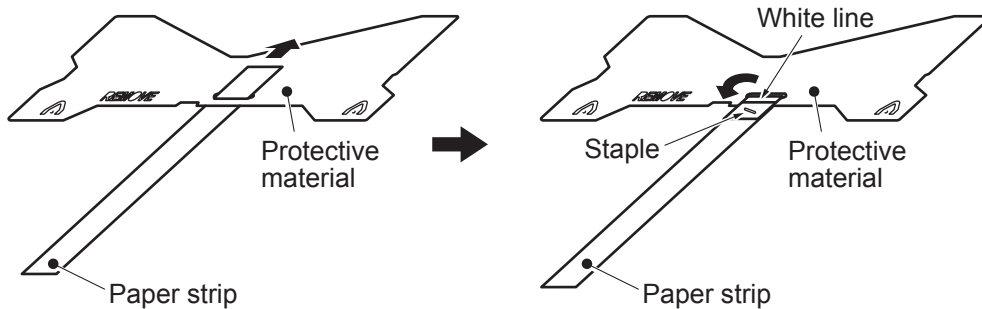


Make the protective material of drum unit by the following procedures, and use it at the time of packing.

### ■ In the case of old type Paper strip

<Procedure>

- (1) Pass the white line side of the Paper strip through the hole of Protective material.
- (2) Bent the Paper strip at the white line part, and then secure it with the Staple.



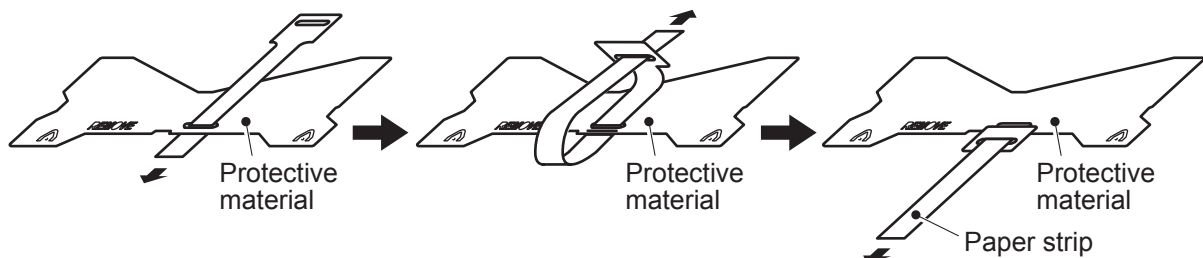
\* The old type of Paper strip can be used for the new type of Protective material.

Fig. APP. 4-1

### ■ In the case of new type Paper strip

<Procedure>

- (1) Pass the Paper strip through the hole of Protective material. (The white surface of Paper strip is the upper side.)
- (2) Pass the end of Paper strip through the hole of Paper strip, and then pull the end of Paper strip to the direction of the arrow.



\* The new type of Paper strip can be used for the old type of Protective material.

Fig. APP. 4-2