

**IBM**

*Personal Computer XT*

---

**Guida  
Operativa**

62X9115

**ATTENZIONE.** Le condizioni di garanzia applicabili al Personal Computer IBM nel paese di acquisto sono disponibili presso i fornitori locali. In Italia valgono solo le condizioni di garanzia in lingua italiana disponibili presso gli appositi centri della IBM o i concessionari IBM. La scheda di garanzia, ove prevista, deve essere conservata insieme alla apposita documentazione comprovante la data di acquisto.



*Personal Computer XT*

---

**Guida  
Operativa**

## Prima edizione (Marzo 1986)

La IBM Italia fornisce questo manuale senza offrire le garanzie usuali come per i prodotti IBM. La IBM si riserva il diritto di apportare miglioramenti o modifiche al prodotto od al programma descritto nel manuale in qualsiasi momento e senza preavviso.

Questa pubblicazione potrebbe contenere informazioni tecniche inconsistenti od errori tipografici. Le correzioni relative saranno incluse nelle nuove edizioni della pubblicazione.

È possibile che questo materiale contenga riferimenti od informazioni su prodotti (macchine o programmi), programmi o servizi IBM, non annunciati. Tali riferimenti od informazioni non possono significare in alcun modo che la IBM Italia intende annunciare tali prodotti, programmi o servizi.

Richieste di ulteriori copie di questo prodotto od informazioni tecniche sullo stesso vanno indirizzate al punto di vendita autorizzato.

© Copyright International Business Machines Corporation 1986

La corrente elettrica che viene dai cavi di alimentazione, telefonici e di comunicazione è pericolosa. Durante l'installazione, il trasferimento o quando si apre il coperchio dei Personal Computer o delle unità collegate, collegare e scollegare i cavi come mostrato in figura.

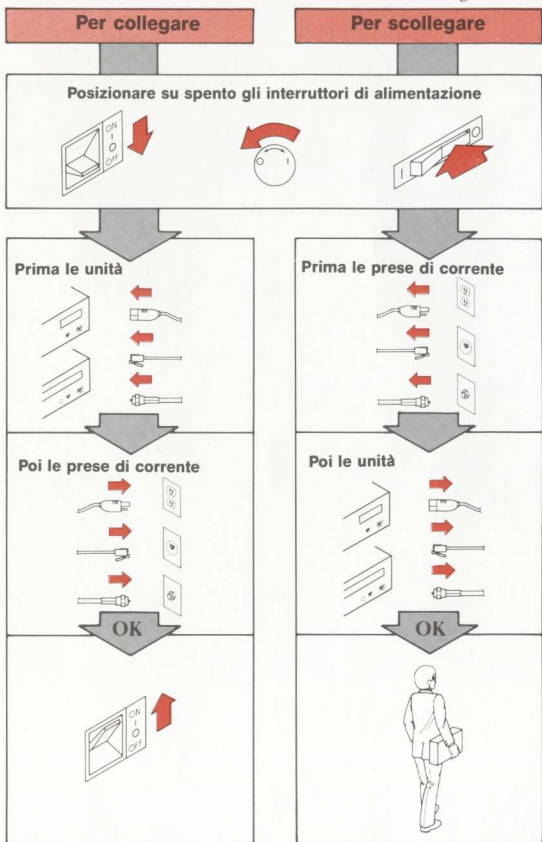

La IBM Italia S.p.A. dichiara a norma dell'articolo 2  
D.M. 9 Ottobre 1980 che il prodotto è conforme alle  
disposizioni del decreto ministeriale stesso e suoi  
allegati (Disposizioni per la prevenzione e  
l'eliminazione dei radiodisturbi provocati da  
apparecchi elettrodomestici, utensili portatili ed  
apparecchi analoghi- G.U. 28/10/1980 n. 296 pag. 9196 e  
segg.). Direttiva CEE/76/889.

# Indice

<b>Sezione 1. Introduzione</b> .....	<b>1-1</b>
Hardware .....	1-2
Software .....	1-3
Utente .....	1-4
<b>Sezione 2. Avviamento</b> .....	<b>2-1</b>
Lista di controllo del sistema .....	2-3
Collegamento .....	2-5
<b>Sezione 3. Come operare sul sistema</b> ..	<b>3-1</b>
Viaggio nel Personal Computer XT IBM	3-3
Unità di sistema .....	3-7
Tastiera .....	3-8
Unità minidisco .....	3-12
A proposito dei minidischi .....	3-13
Protezione da scrittura .....	3-14
Caricamento dell'unità minidisco ..	3-15
Unità a disco fisso .....	3-16
Video .....	3-17
Trasferimento del sistema .....	3-18
Trasferimento a lungo raggio .....	3-22
Installazione nella nuova sede ....	3-22
<b>Sezione 4. Installazione delle opzioni</b> ..	<b>4-1</b>
Opzioni interne .....	4-3
Rimozione del coperchio .....	4-5
Interruttori della scheda di sistema ....	4-8
Coproprocessore .....	4-10
Memoria .....	4-10
Video .....	4-11
Unità minidisco .....	4-12
Installazione del coperchio .....	4-13
Opzioni esterne .....	4-15
<b>Sezione 5. Prova del sistema</b> .....	<b>5-1</b>
Software .....	5-3
Hardware .....	5-4

Hardware .....	5-4
Prova automatica .....	5-5
Messaggi di errore della prova automatica .....	5-8
Sintomi di errore .....	5-13
Prove di sistema .....	5-15
Problemi riguardanti il video .....	5-20
Problemi riguardanti la stampatrice .....	5-24
<b>Appendice A. Mascherine di tastiera .....</b>	<b>A-1</b>
Introduzione .....	A-2
Francese .....	A-4
Tedesco .....	A-6
Italiano .....	A-8
Spagnolo .....	A-10
Inglese U.K. ....	A-12
Inglese U.S. ....	A-14
<b>Appendice B. Numeri di serie .....</b>	<b>B-1</b>
<b>Glossario .....</b>	<b>X-1</b>
<b>Indice analitico .....</b>	<b>X-5</b>

# Sezione 1. Introduzione

Il Personal Computer XT IBM è un sistema con una tastiera ed almeno un'unità minidisco. L'unità di sistema è la parte centrale e prevede una varietà di opzioni. La tastiera, che viene usata per inviare i dati al sistema, è collegata tramite un cavo a spirale. L'unità minidisco installata nell'unità di sistema può leggere e registrare dati da o su un minidisco.

Per adattare il sistema alle proprie necessità, è possibile scegliere opzioni interne ed esterne che eseguano le funzioni desiderate. Un esempio di opzione interna è l'Adattatore video colore/grafici che consente di collegare al sistema un video a colori, che a sua volta è un'opzione esterna. Per espandere il sistema è possibile aggiungere un video, una stampatrice, memoria addizionale o altre opzioni.

L'hardware da solo non forma un sistema PC XT IBM completo e funzionante. Per averlo completo e funzionante, sono necessari tre elementi:

- L'hardware
- Il software
- L'utente.

# Hardware

I requisiti hardware minimi sono:

- L'unità di sistema con una unità minidisco
- La tastiera
- Il video.

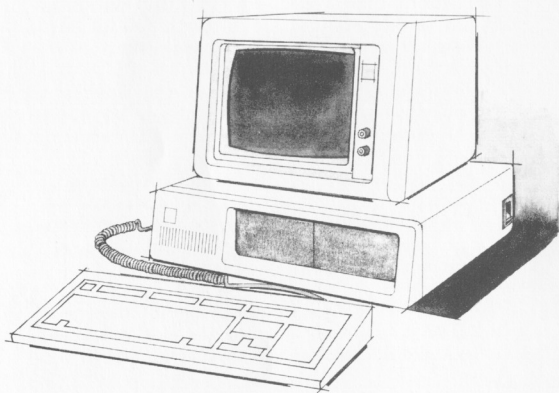

# Software

Il software può essere costituito da uno dei seguenti elementi:

- Sistema operativo su disco (DOS)
- Programma giochi
- Programma finanziario
- Linguaggio di programmazione, come per esempio il BASIC
- Altri programmi.

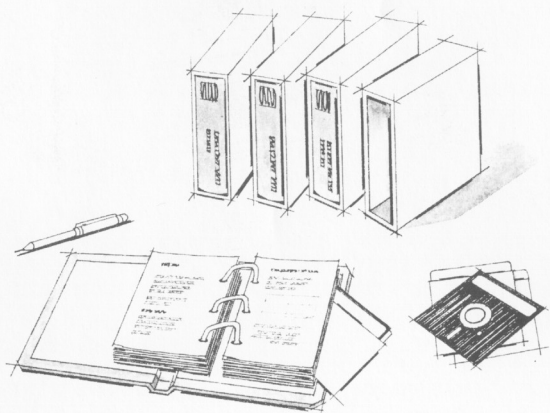

# Utente

L'utente è l'elemento più importante di un efficiente PC XT IBM. L'utente unisce gli elementi dell'hardware e del software. La *Guida operativa*, questo manuale, aiuterà a familiarizzare con la parte hardware del sistema.



La *Guida operativa* può essere utilizzata come manuale di riferimento. Probabilmente, ogni volta che si usa questo manuale, verranno usate solo una parte delle informazioni in esso contenute. Le risposte alle domande della sezione successiva, "Avviamento", saranno di guida nella lettura del manuale.

Continuare con la sezione successiva.

## Sezione 2. Avviamento

A questo punto si è pronti per iniziare. I passi seguenti aiuteranno a determinare quale sezione della *Guida operativa* utilizzare.

**1** **Nell'unità di sistema sono state installate tutte le opzioni interne?**

*Nota:* Le opzioni interne sono parti installate *all'interno* dell'unità di sistema, come per esempio l'adattatore al quale è collegato il video.

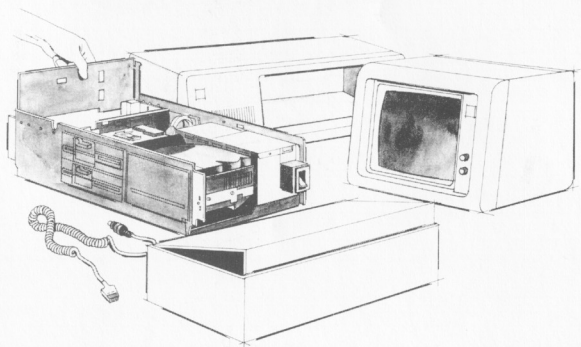

**SI** Continuare con il passo successivo.

**NO** Andare a "Opzioni interne" a pagina 4-3.

2 Il PC XT IBM è collegato e pronto per essere utilizzato?

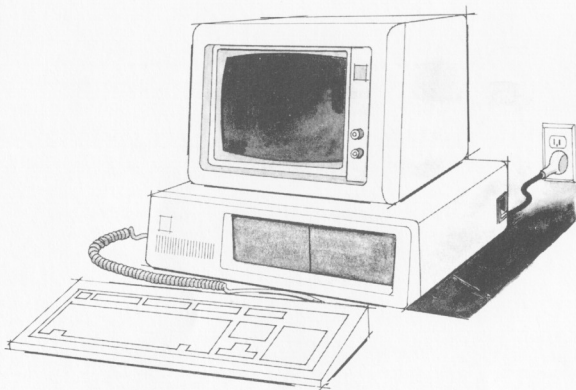

**SI** Andare a “Viaggio nel Personal Computer XT IBM” a pagina 3-3.

**NO** Continuare con “Lista di controllo del sistema” a pagina 2-3.

# Lista di controllo del sistema

**IMPORTANTE:** Prima di collegare il cavo di alimentazione all'unità di sistema, assicurarsi che:

- Il coperchio dell'unità di sistema sia montato e che siano installate le viti di fissaggio del coperchio.

Viti di fissaggio del coperchio

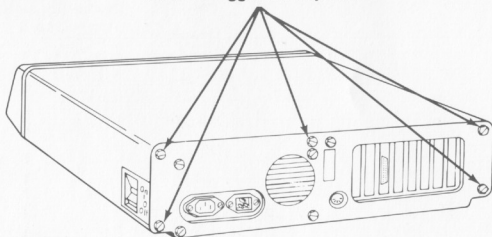

- I numeri di serie dei componenti del sistema siano riportati nell'apposito schema dell'"Appendice B".

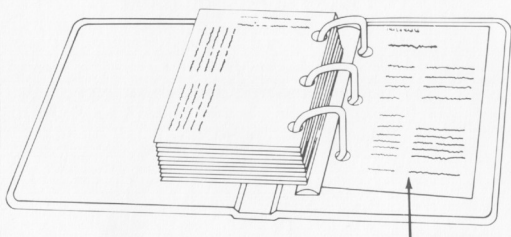

**Numeri di serie  
Appendice B**

Nella figura che segue viene mostrata la posizione del numero di serie dell'unità di sistema.

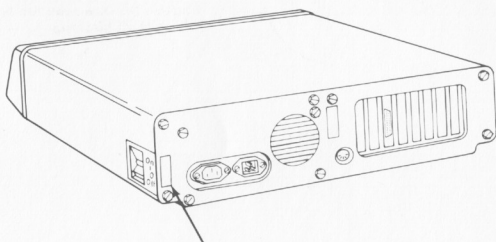

**Numero di serie dell'unità di sistema**

# Collegamento

- 1 Spegnere l'unità di sistema.

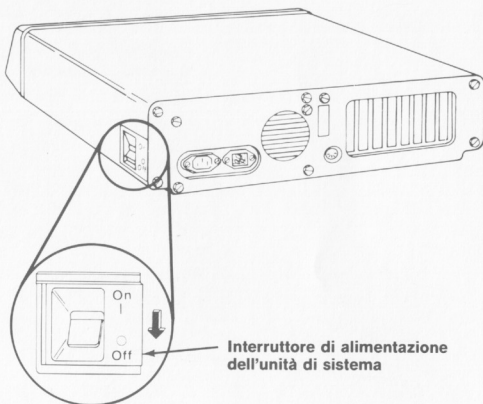

- 2 Spegnere tutte le opzioni esterne (stampante, video ed altre eventuali).

- 3 Collegare all'unità di sistema e alla tastiera i cavi del video e della tastiera, come mostrato di seguito.

**Attenzione:** Il video monocromatico IBM potrebbe subire danni se collegato ad un Adattatore video colore/grafici IBM.

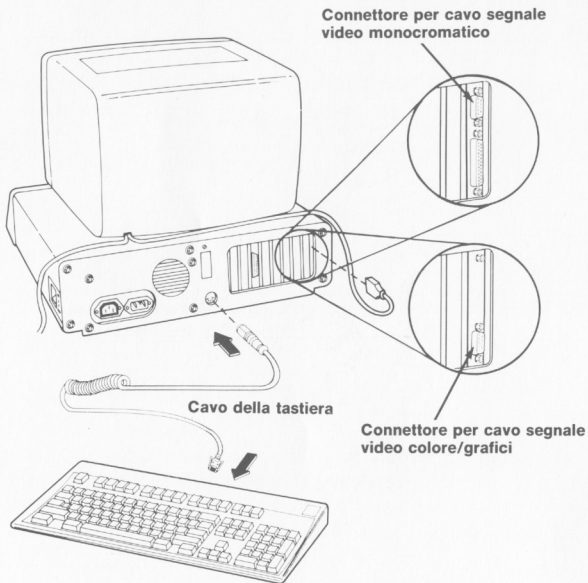

4 **Si sta installando una stampatrice?**

**SI.** Continuare con il passo successivo.

**NO** Andare al passo 9 a pagina 2-9.

5 Collegare il cavo della stampatrice all'adattatore appropriato sull'unità di sistema.

*Nota:* Collegare la stampatrice all'Adattatore video monocromatico e stampatrice IBM, se presente. Altrimenti, collegare la stampatrice ad un qualsiasi adattatore per stampatrici.

**Adattore video monocromatico e stampatrice IBM**

**o Adattatore stampatrice**



6 Fissare le viti.

- 7 Se la stampatrice non è ancora attivata, per completarne l'installazione fare riferimento alle istruzioni con essa fornite.
- 8 Collegare il cavo di alimentazione della stampatrice alla stampatrice e quindi inserirlo nella presa di corrente.

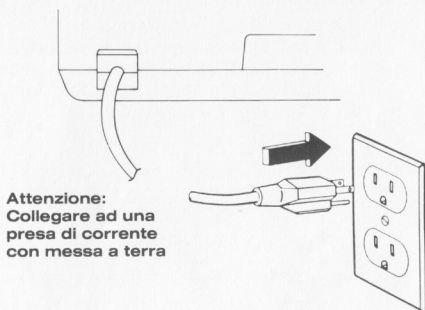

### Avvertenza

Questo prodotto viene fornito con un cavo ed una spina disegnati per la sicurezza dell'utente. Per evitare possibili scariche elettriche deve essere usato con una presa di corrente con messa a terra.

- 9 Collegare il cavo di alimentazione all'unità di sistema e quindi inserirlo nella presa di corrente.

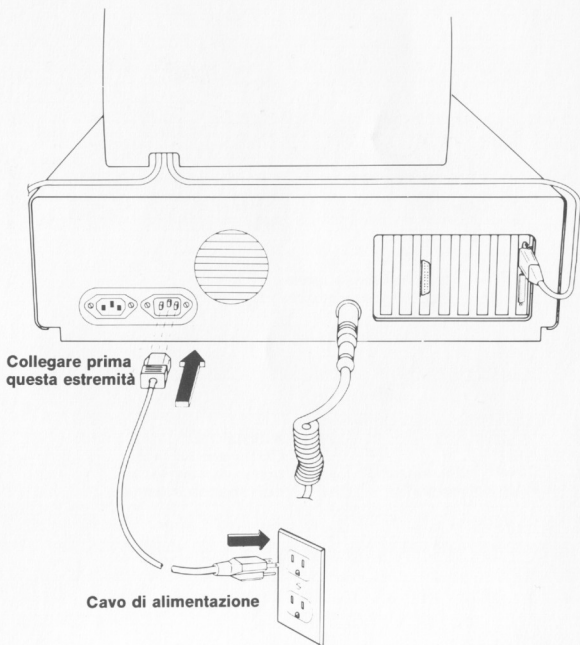

- 10 Collegare, come indicato, i cavi di alimentazione per le altre opzioni esterne.

*Nota:* Se l'opzione esterna ha un cavo di alimentazione separabile, collegarlo prima all'opzione e dopo inserirlo nella presa di corrente.

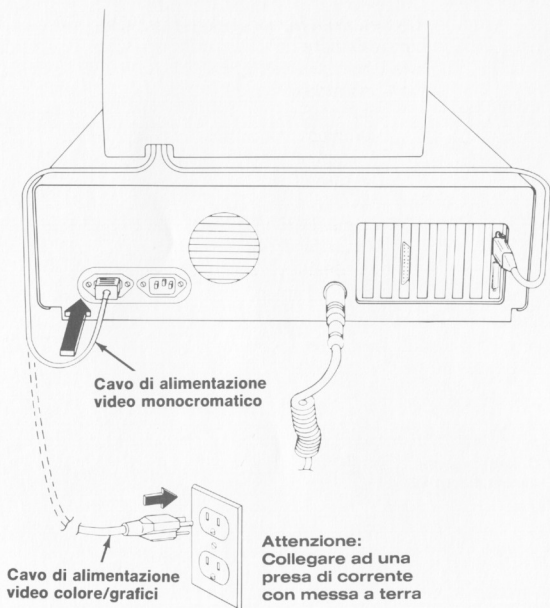

- 11 Continuare con la sezione successiva.

## Sezione 3. Come operare sul sistema

Esplorando il Personal Computer IBM XT ...	3-3
Unità di sistema .....	3-7
Tastiera .....	3-8
Unità minidisco .....	3-13
A proposito dei minidischi .....	3-14
Protezione da scrittura .....	3-15
Caricamento dell'unità minidisco .....	3-16
Unità a disco fisso .....	3-17
Video .....	3-18
Trasferimento del sistema .....	3-19
Trasferimento a lungo raggio .....	3-23
Installazione nella nuova sede .....	3-23

Note:

# Viaggio nel Personal Computer XT IBM

Alla *Guida operativa* è allegato un minidisco chiamato "Viaggio nel Personal Computer XT IBM". Il programma su questo minidisco è concepito per essere di aiuto nella comprensione e nell'uso del sistema. Prendere il minidisco "Viaggio nel Personal Computer XT IBM" in fondo a questo manuale e continuare con la pagina successiva.

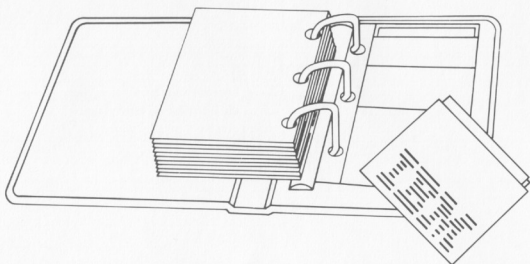

- 1 Spegnere l'unità di sistema.

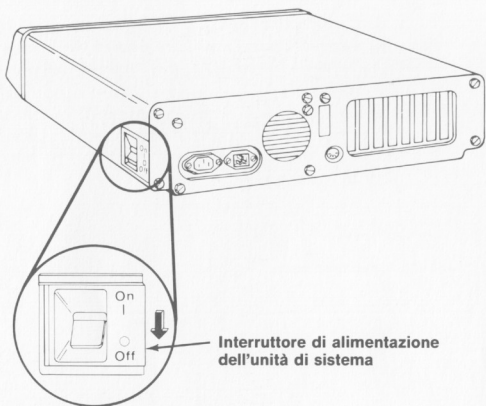

- 2 Inserire il minidisco "Viaggio nel Personal Computer XT IBM" nell'unità A.

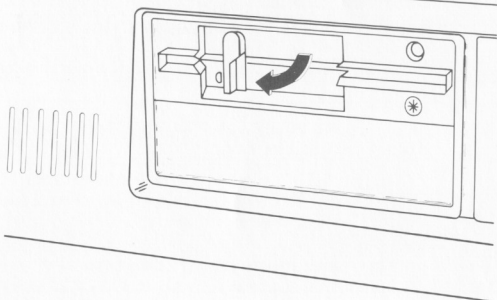
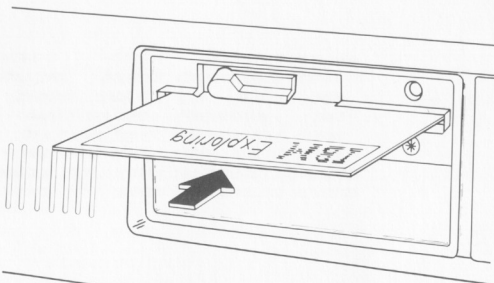

- 3 Girare in senso orario le manopole di controllo del video.
- 4 Accendere tutte le opzioni esterne (stampatrice, video ed altre eventuali).
- 5 Accendere l'unità di sistema.
- 6 Regolare appropriatamente le manopole di controllo del video.

7 Appare lo schermo seguente?



Presenta

**SI** Seguire le istruzioni sullo schermo.

**NO** Rimuovere il minidisco e verificare che:

- Sia il minidisco "Viaggio nel Personal Computer XT IBM".
- Sia stato caricato appropriatamente. Per verificare questo, cominciare dal passo 1 a pagina 3-4.

Se il minidisco è stato caricato correttamente e non appare lo schermo sopra riportato, andare alla "Sezione 5, Prova del sistema".

# Unità di sistema

La parte principale del PC XT IBM è l'unità di sistema. Essa elabora i dati e controlla le operazioni del sistema attraverso una serie di istruzioni chiamate *software* o *programma*. Il PC XT IBM viene fornito con un linguaggio di programmazione installato chiamato BASIC IBM. Presso il proprio fornitore viene distribuita una grande varietà di programmi.

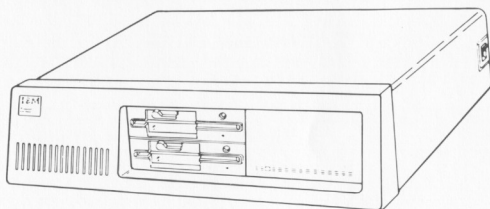

# Tastiera

La tastiera è divisa in quattro sezioni: l'area dattilografica, i tasti funzionali, la tastierina numerica e l'area dei tasti di controllo.

*Nota:* In questi esempi viene usata la tastiera a 101 tasti. I caratteri dei tasti della parte superiore della tastiera a 102 tasti vengono mostrati nella sezione "Mascherine di tastiera" di questo manuale.

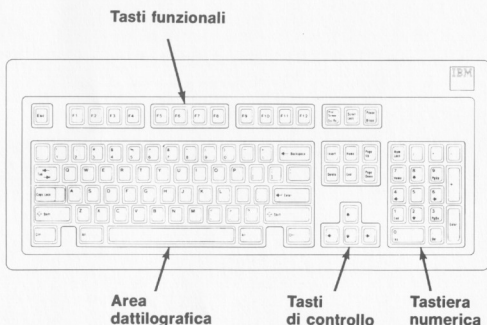

## Area dattilografica

La maggior parte dei tasti sono ripetitivi, cioè in grado di ripetere la battuta per tutta la durata del tempo in cui è esercitata la pressione. I tasti dell'area dattilografica sono simili a quelli di una comune macchina per scrivere, con le seguenti eccezioni.

Ci sono due identificatori di inizio riga. Questi identificatori sono righe orizzontali in rilievo che si trovano sui tasti **F** e **J** e che permettono di

localizzare la riga base senza dover guardare la tastiera.

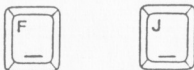

## Area dei tasti funzionali

Dodici tasti funzionali, al di sopra dell'area dattilografica, si trovano sotto il controllo del programma. La loro funzione è definita nel sistema operativo o nel manuale del programma applicativo.



## Area della tastierina numerica

Premendo una volta il tasto BlocNum, i tasti di controllo del cursore diventano tasti numerici e i tasti delle maiuscole lavorano in modo inverso. In modo **BlocNum**, per usare i tasti della tastierina numerica come tasti di controllo cursore, è necessario tenere premuto il tasto Maius (⇧). Per comodità dell'utente, la tastierina è predisposta come una calcolatrice. Premendo nuovamente il tasto **BlocNum**, i tasti da 0 a 9 tornano ad essere tasti controllo cursore.



La tastierina numerica ha un identificatore sul tasto 5. Tale identificatore è una riga orizzontale in rilievo sul tasto che consente di localizzare il centro della tastierina numerica senza doverla guardare.



### Area dei tasti di controllo

I tasti di controllo vengono usati per il controllo del cursore e del programma.

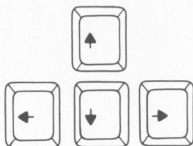
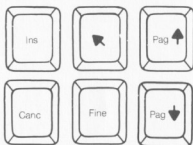

Tali tasti sono separati dalla tastierina numerica e funzionano nello stesso modo dei tasti di

controllo del cursore presenti sulla tastierina.  
Servono comunque esclusivamente per il  
controllo del cursore e non vengono influenzati  
dal tasto **BlocNum**.

## Regolazione altezza tastiera

Per comodità di battuta, è possibile regolare la tastiera in due diverse posizioni.

Per far ciò, capovolgere la tastiera e mettere i relativi piedini nella posizione desiderata.

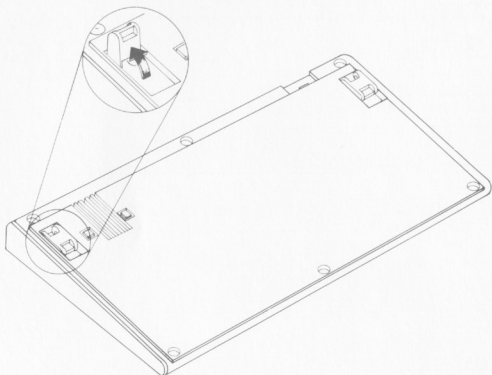

# Unità minidisco

Le unità minidisco vengono usate per leggere e registrare i dati sui minidischi. Nel sistema è possibile installare due unità minidisco.

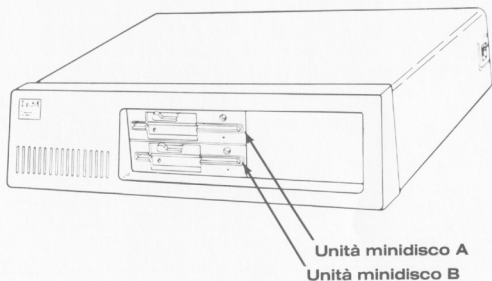

# A proposito dei minidischi

Un minidisco è un disco magnetico da 5-1/4 pollici contenuto in un involucro di plastica protettivo. I minidischi vengono usati per memorizzare i dati.

La scelta del minidisco corretto è *importante* per la riuscita delle operazioni eseguite con il PC XT IBM.

## Uso dei minidischi

Le seguenti illustrazioni mostrano alcuni modi corretti e non corretti nel maneggiare i minidischi. Seguendo queste indicazioni, si ridurrà considerevolmente la possibilità di danneggiarli.



## Protezione da scrittura

Quando un minidisco è protetto da scrittura, nessuna informazione può esservi registrata (scritta). Per rendere un minidisco protetto da scrittura, coprire la tacca laterale con una fascetta di protezione dalla scrittura. Se si desidera registrare (scrivere) informazioni sul minidisco, rimuovere la fascetta.

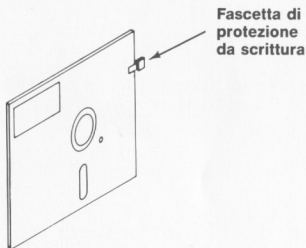

# Caricamento dell'unità minidisco

- 1 Quando il minidisco è stato completamente inserito, si avverte uno scatto. Quando la luce di segnalazione di utilizzo dell'unità è accesa, il sistema sta utilizzando l'unità minidisco.

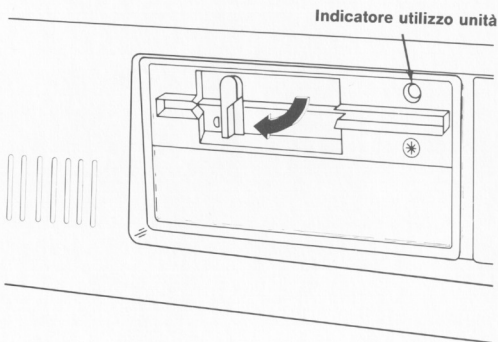
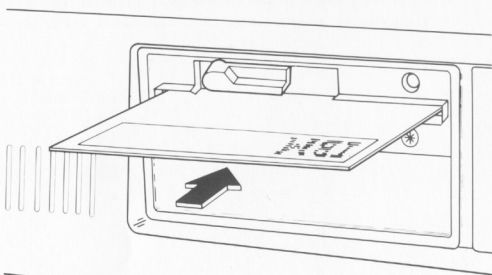

- 2 Per rimuovere un minidisco dalla relativa unità, ruotare la levetta in senso antiorario ed estrarre il minidisco. Non rimuovere il minidisco quando la luce di segnalazione di utilizzo dell'unità è accesa.

# Unità a disco fisso

Per memorizzare e recuperare i dati, il disco fisso ha bisogno di un sistema operativo, come per esempio il DOS IBM.

Nel sistema è possibile installare un'unità a disco fisso (così come una o due unità minidisco).

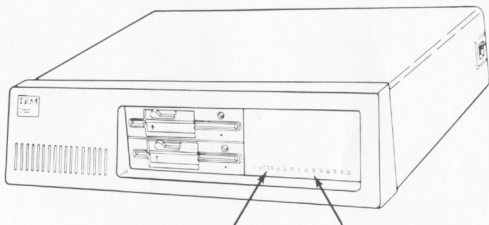

**Indicatore utilizzo unità      Unità a disco fisso C**

# Video

Tutti i video a colori IBM hanno una manopola di accensione. Una spia luminosa segnala quando il video è acceso.

Il video monocromatico IBM è collegato al retro dell'unità di sistema e si accende e si spegne insieme all'unità.

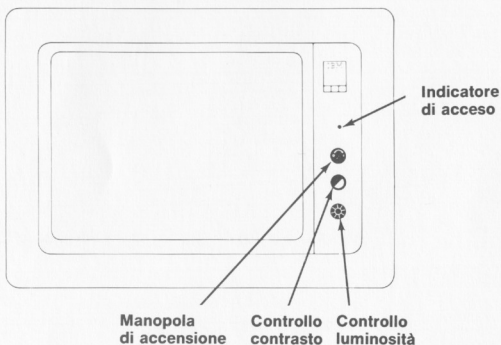

# Trasferimento del sistema

**L'unità è un'unità a disco fisso?**

**SI** Per evitare la perdita dei dati memorizzati su un'unità a disco fisso, prima di trasferire il sistema fare una copia di riserva di tutti i file. (Per le istruzioni relative alla copia di riserva dei file, vedere il manuale del sistema operativo).

Quando tutti i file sono stati copiati, continuare con il passo 1.

**NO** Andare al passo 7.

- 1** Caricare nell'unità **A** il minidisco dei Diagnostici (che si trova in fondo a questo manuale).
- 2** Accendere l'unità di sistema.

- 3 Sullo schermo appare quanto segue.

DIAGNOSTICI del Personal Computer IBM  
Livello X.XX (C) Copyright IBM Corp. 1986

SELEZIONARE UNA SCELTA

- 0 - PROVA SISTEMA
- 1 - FORMATTAZIONE MINIDISCO
- 2 - COPIA MINIDISCO
- 3 - PREPARAZ. SISTEMA PER TRASFERIMENTO
- 9 - FINE DIAGNOSTICI

IMMETTERE NUMERO FUNZIONE DESIDERATA  
?

- 4 Immettere **3** e quindi premere il tasto di **Invio** (←↵).

- 5 Quando sullo schermo appare il seguente messaggio, l'unità a disco fisso è pronta per essere trasferita.

SELEZIONARE UNA SCELTA

- 0 - PROVA SISTEMA
- 1 - FORMATTAZIONE MINIDISCO
- 2 - COPIA MINIDISCO
- 3 - PREPARAZ. SISTEMA PER TRASFERIMENTO
- 9 - FINE DIAGNOSTICI

IMMETTERE NUMERO FUNZIONE DESIDERATA

? 3

SISTEMA PRONTO PER TRASFERIMENTO

- 6 Rimuovere il minidisco dei Diagnostici.
- 7 Spegnere l'unità di sistema.
- 8 Spegnere tutte le opzioni esterne.

- 9 Inserire in ciascuna unità minidisco un cartoncino di protezione. Ruotare la levetta dell'unità minidisco in senso orario.

*Nota:* Se il cartoncino di protezione non è disponibile, usare un minidisco vuoto.

**Cartoncino di protezione**

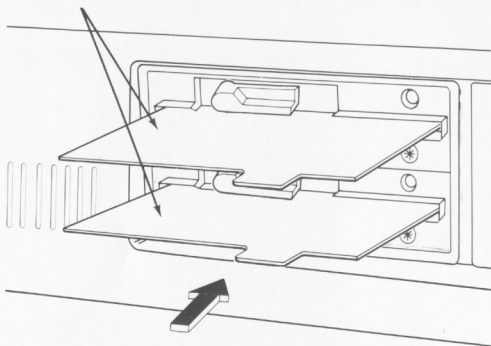

- 10 Scollegare il cavo di alimentazione dell'unità di sistema dalla presa di corrente. Scollegare anche tutte le opzioni esterne.
- 11 Scollegare ed assicurare tutti i cavi.

## **Trasferimento a lungo raggio**

Se possibile, utilizzare tutti i materiali di imballaggio originali del PC XT IBM.

Altrimenti, usare altri imballaggi avvolgendo attentamente le unità per impedirne qualsiasi danneggiamento.

## **Installazione nella nuova sede**

Quando il sistema arriva nella nuova sede, togliere l'imballaggio con cura.

Per installare e collegare il sistema, fare riferimento a "Lista di controllo del sistema" a pagina 2-3.

**Note:**

## Sezione 4. Installazione delle opzioni

Opzioni interne .....	4-3
Rimozione del coperchio .....	4-5
Interruttori della scheda di sistema ....	4-8
Coproprocessore .....	4-10
Memoria .....	4-10
Video .....	4-11
Unità minidisco .....	4-12
Installazione del coperchio .....	4-14
Opzioni esterne .....	4-15

Note:

# Opzioni interne

Le opzioni interne sono parti installate all'interno dell'unità di sistema. Di seguito sono riportate alcune opzioni interne disponibili per il sistema.

- Opzioni di espansione di memoria
- Adattatori video
- Unità minidisco
- Adattatori stampatrice o di comunicazione.

Le opzioni sono fornite di istruzioni scritte per il PC XT IBM. Inserire nella sezione appropriata le istruzioni dell'opzione che si desiderano conservare.

Prima di tutto, installare le opzioni di memoria sulla scheda di sistema. Solo l'Adattatore per le comunicazioni asincrone può essere installato nell'alloggiamento di espansione 8 del PC XT IBM. Installare le altre opzioni nell'ordine più appropriato.

**Prima di poter installare qualsiasi opzione interna, rimuovere il coperchio seguendo le procedure riportate in questa sezione.**

## Strumenti necessari

- Giravite medio a lama piatta
- Giravite piccolo a lama piatta.

Note:

# Rimozione del coperchio

- 1 Spegnere l'unità di sistema.

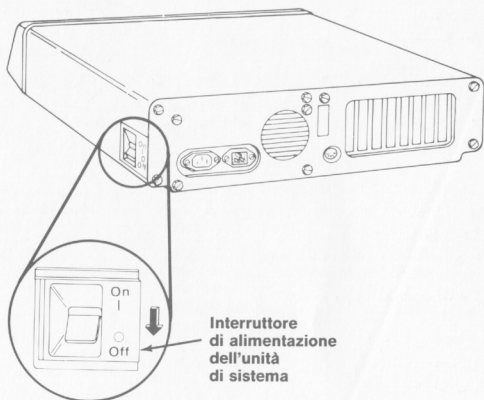

- 2 Spegnere tutte le opzioni esterne (stampatrice, video ed altre eventuali).
- 3 Scollegare il cavo di alimentazione dell'unità di sistema dalla presa di corrente.
- 4 Scollegare le opzioni esterne dalla presa di corrente.

- 5 Prendere nota della posizione dei cavi e scollegarli dalla parte posteriore dell'unità di sistema.

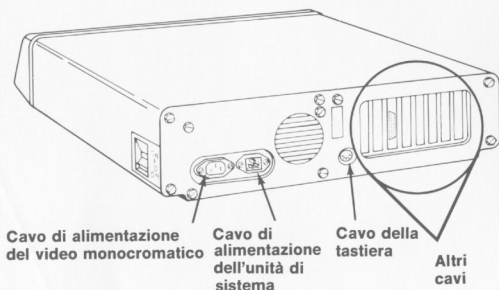

- 6 Rimuovere le viti di fissaggio del coperchio.

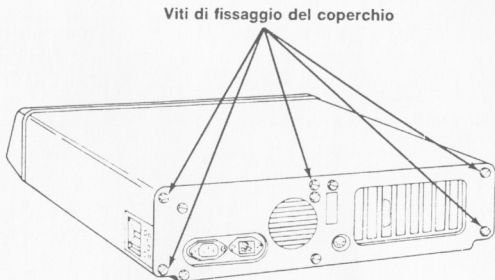

- 7 Per rimuovere il coperchio:
- Farlo scivolare in avanti fino a che si ferma.
  - Piegarlo verso l'alto per rimuoverlo dalla base.

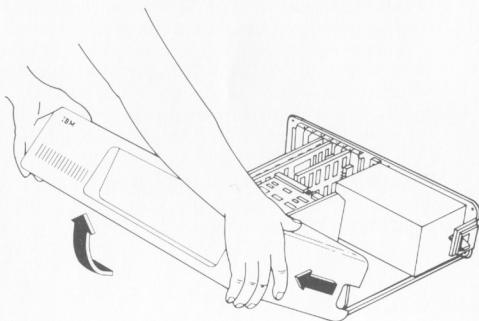

- 8 Continuare con le istruzioni fornite con l'opzione che si sta installando.

# Interruttori della scheda di sistema

Alloggiamenti espansione  
unità di sistema

Connettore per  
cavo della tastiera

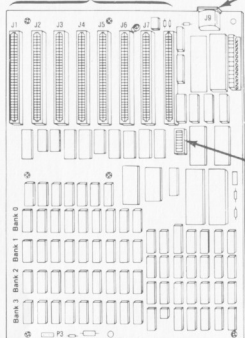

Blocco degli  
interruttori

Parte frontale

Gli interruttori sulla scheda di sistema sono impostati come mostrato nella figura che segue e nelle pagine successive. Queste impostazioni sono necessarie al sistema per riconoscere le opzioni collegate e per specificare la quantità di memoria sulla scheda di sistema. Impostare l'interruttore a levetta abbassando la levetta nella posizione desiderata. Per gli interruttori a cursore, spingere il cursore nella posizione desiderata.

**Attenzione:** Prima di cambiare l'impostazione degli interruttori, prendere nota della loro posizione attuale.

**Nota:** Alcuni blocchi degli interruttori sono etichettati ON e OFF; altri ON e OPEN. OPEN equivale a OFF.

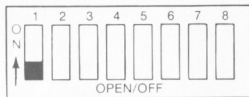

Blocco degli interruttori

<i>Interruttore</i>	<i>Funzione</i>
1	Operazione normale; impostato sempre su Off (spento)
2	Coprocessore
3-4	Quantità di memoria sulla scheda di sistema
5-6	Tipo di video collegato
7-8	Numero di unità minidisco installate

# Coprocessore

L'interruttore 2 viene impostato per indicare se il coprocessore è installato.

Con coprocessore

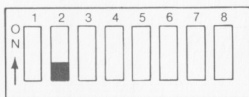

Senza coprocessore

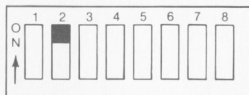

# Memoria

Le figure che seguono mostrano l'impostazione degli interruttori 3 e 4 per la quantità di memoria sulla scheda di sistema.

256K



512K

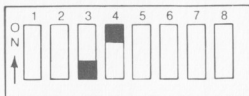

640K

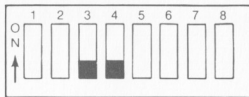

# Video

Le figure che seguono indicano come devono essere impostati gli interruttori 5 e 6 per il tipo di adattatore video installato nel sistema. Se il video non si trova tra quelli sotto riportati, controllare le istruzioni fornite con l'adattatore video.

**Attenzione:** Se al sistema è collegato un video monocromatico IBM, esso deve essere collegato ad un Adattatore Video Monocromatico e Stampatrice o ad un Adattatore Video Grafici Avanzati. Gli interruttori 5 e 6 devono essere installati correttamente a seconda del tipo di adattatore installato. Se non si segue attentamente questa avvertenza, il video potrebbe subire danni.



Adattatore Grafici Avanzati IBM (da solo o con un altro adattatore) o NESSUN adattatore.



Adattatore Colore/Grafici IBM in modo Colore 40x25.

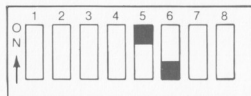

Adattatore Colore/Grafici IBM in modo Colore 80x25.



Adattatore Monocromatico e Stampatrice IBM o Adattatore Monocromatico e Stampatrice IBM insieme all'Adattatore Colore/Grafici.

*Nota:* Il modo 40x25 indica uno schermo largo 40 caratteri per 25 righe di altezza. Il modo 80x25 indica uno schermo largo 80 caratteri per 25 righe di altezza. Il modo 80x25, quando usato con apparecchi televisivi e vari video, può causare una perdita nella qualità dei caratteri.

# Unità minidisco

Le figure che seguono mostrano l'impostazione degli interruttori 7 ed 8 a seconda del numero di unità minidisco installate.

**1 Unità minidisco**

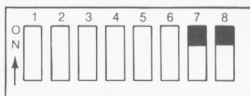

**2 Unità minidisco**

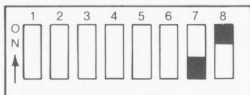

Note:

# Installazione del coperchio

- 1 Installare il coperchio dell'unità di sistema.

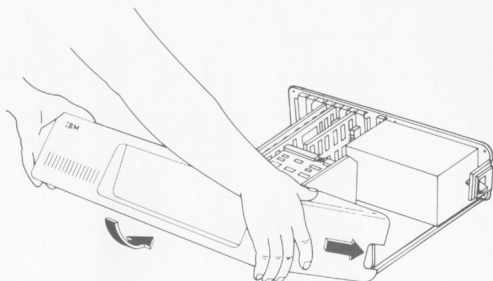

- 2 Installare le viti di fissaggio del coperchio.

Viti di fissaggio del coperchio

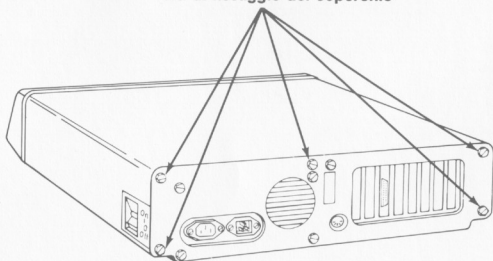

- 3 Se è necessario installare altre opzioni esterne all'unità di sistema, continuare con "Opzioni esterne" a pagina 4-15. Altrimenti, andare a "Lista di controllo del sistema" a pagina 2-3.

# Opzioni esterne

Le opzioni esterne si collegano *all'esterno* del PC XT IBM. Alcune opzioni esterne disponibili per il sistema sono:

- Video
- Stampatrice o unità di comunicazione
- Cavi.

Usare le procedure di installazione ed operative fornite con l'opzione.

*Nota:* Quando le opzioni sono fornite di istruzioni operative separate, è possibile inserire tali istruzioni in questo manuale.

## Strumenti necessari

- Giravite medio a lama piatta
- Giravite medio a croce (solo per le stampatrici)

- 1 Spegnere l'unità di sistema.
- 2 Spegnere tutte le opzioni esterne (stampatrice, video ed altre eventuali).
- 3 Scollegare dalle prese di corrente i cavi di alimentazione (sistema, stampatrice, video ed altri eventuali).

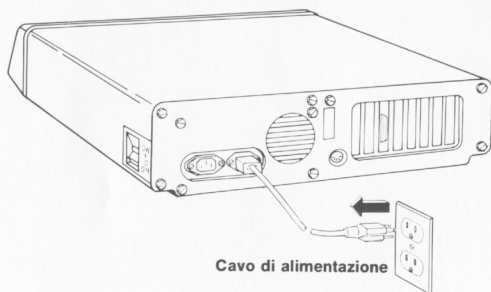

- 4 Continuare con le istruzioni fornite con l'opzione che si sta installando.

## Sezione 5. Prova del sistema

I problemi riguardanti il sistema possono essere causati dal software, dall'hardware o da entrambi. Questa sezione aiuterà a determinare la causa di un problema e l'azione da intraprendere.

*Nota:* Usare questa sezione per provare *solamente* prodotti IBM. Prodotti non IBM possono dare errori o risposte di sistema non validi.

Alcune unità che si collegano al sistema sono fornite di manuali con istruzioni di prova, alle quali è necessario far riferimento al momento di provare tali unità.

In caso non si abbiano problemi con il sistema ma si voglia solamente verificare che esso operi correttamente, cominciare con "Prove di sistema".

Se si decide di richiedere assistenza tecnica per il sistema, ricordarsi di portare i cavi di alimentazione e le chiavi. Questo manuale riporta le informazioni necessarie al trasferimento del sistema nella Sezione 3.

Alcune opzioni che è possibile aggiungere al sistema sono fornite di pagine sostitutive o addizionali per questa sezione e di un minidisco dei Diagnostici. Confrontare la data delle pagine sostitutive con quella della pagine di questa sezione di "Prova". Mantenere le pagine con la data più recente. Confrontare il numero di versione del minidisco dei Diagnostici con il numero di versione del minidisco dei Diagnostici allegato a questo manuale. Tenere il minidisco con il numero di versione più alto.

Prima di tutto, fare una nota di qualsiasi sintomo o messaggio ricevuto e quindi continuare con la pagina successiva.

# Software

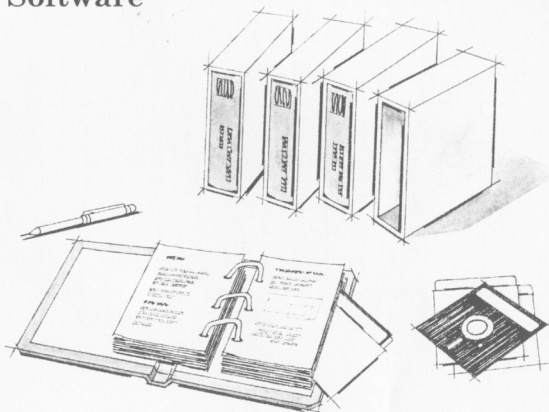

Utilizzando il software, è possibile ricevere messaggi di errore. Per una descrizione di tali messaggi, fare riferimento al manuale software.

Prima di continuare, assicurarsi che:

- Il software sia disegnato per il sistema.
- Il sistema abbia i requisiti minimi per usare il software.
- Il software dell'utente operi correttamente su un altro sistema.

Se quanto riportato sopra non è di aiuto, continuare con "Hardware" nella pagina successiva.

# Hardware

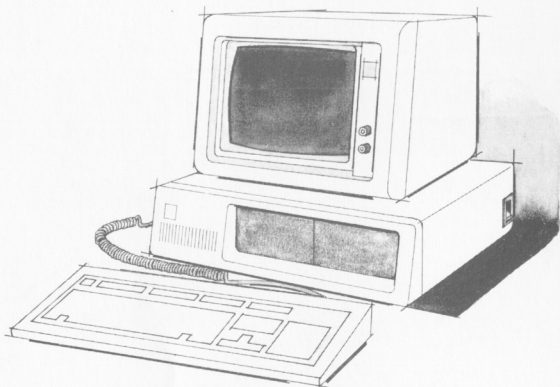

Prima di continuare, assicurarsi che:

- La presa di corrente sia funzionante.
- Tutti i cavi, sia di collegamento che di alimentazione, siano collegati appropriatamente.
- Sia tutto acceso.
- Le manopole di controllo del contrasto e della luminosità siano regolate appropriatamente.

Se un'opzione è stata appena installata, assicurarsi che:

- L'opzione sia disegnata per il sistema.
- L'opzione sia stata installata secondo le relative istruzioni.

Se quanto riportato sopra non è di aiuto, continuare con "Prova automatica" nella pagina successiva.

## Prova automatica

Ogni volta che viene acceso, il sistema esegue una prova automatica. Seguire questi passi per osservare la prova automatica.

**Fare molta attenzione ai segnali acustici.**

- 1 Spegnere il sistema.
- 2 Prendere il minidisco dei Diagnostici in fondo a questo manuale.
- 3 Caricare il minidisco nell'unità A.
- 4 Accendere il sistema.

- 5 Il Personal Computer XT mostra la quantità di memoria nell'angolo superiore sinistro dello schermo. Tale numero si incrementa fino a corrispondere alla quantità di memoria installata nel sistema.



XXX KB OK

**Nota:** Durante la prova automatica, invece della quantità di memoria, il PC XT mostra un cursore lampeggiante.



---

- La spia dell'unità minidisco lampeggia.
- Si sente un segnale acustico.

- 6 Quando la prova automatica si completa, appare lo schermo seguente.

DIAGNOSTICI del Personal Computer IBM  
Livello XXX (C) Copyright IBM Corp 1986

SELEZIONARE UNA SCELTA

- 0 - PROVA SISTEMA
- 1 - FORMATTAZIONE MINIDISCO
- 2 - COPIA MINIDISCO
- 3 - PREPARAZ. SISTEMA PER TRASFERIMENTO
- 9 - FINE DIAGNOSTICI

IMMETTERE NUMERO FUNZIONE DESIDERATA  
?

- 7 Il sistema ha risposto nel modo descritto?

**SI** Andare a "Prove di sistema".

**NO** Continuare con "Messaggi di errore della prova automatica" nella pagina successiva.

# Messaggi di errore della prova automatica

Trovare il messaggio ricevuto ed intraprendere l'azione descritta.

6XX - Diskette Boot Record Error  
or  
Diskette Boot Failure

(X può essere un numero qualsiasi).

**Azione** Assicurarsi di usare il minidisco dei Diagnostici e che tale minidisco sia caricato correttamente.

Cercare di avviare nuovamente il minidisco dei Diagnostici. Se non è possibile, richiedere assistenza tecnica per l'unità di sistema.

1801

XXX KB OK

ERROR.(RESUME="F1"KEY)

**Azione** Spegner e l'unità di sistema e l'unità di espansione per alcuni secondi.

Accendere l'unità di espansione.

Accendere l'unità di sistema.

Se l'errore **1801** rimane, richiedere assistenza tecnica per l'unità di espansione.

Se non si è ricevuto alcuno dei messaggi di errore sopra riportati, continuare con la pagina successiva.

Se è stato ricevuto il messaggio che segue, intraprendere l'azione descritta.

XX 301

(X può essere un numero qualsiasi).

**Azione** Assicurarsi che la tastiera sia collegata correttamente e che non ci sia qualcosa sopra che tenga premuto qualche tasto. Se nessun tasto risulta premuto, tentare una delle seguenti azioni:

Spegnere l'unità di sistema. Attendere qualche secondo.

Accendere l'unità di sistema.

Se l'errore **301** rimane, richiedere assistenza tecnica per l'unità di sistema, la tastiera ed il relativo cavo.

Se non è stato ricevuto il messaggio di errore sopra riportato, continuare con la pagina successiva.

Se è stato ricevuto qualcuno dei seguenti messaggi, intraprendere l'azione descritta. Altrimenti, andare a "Sintomi di errore". (X può essere un numero qualsiasi).

1XX  
601  
17XX  
22XX-Cluster Failure  
30XX-Network Failure  
    except 3015\* and 3042\*  
31XX-Network Failure  
    except 3115\* and 3142\*  
CC000  
C8000  
FXXXX  
Parity Check X  
ROM Error  
XXXXX  
XXXX 20X  
XXXXX XX 20X

\*Se è stato ricevuto uno di questi errori, richiedere assistenza tecnica per la rete.

**Azione** All'unità di sistema è collegata un'unità di espansione?

**NO** Richiedere assistenza tecnica per l'unità di sistema.

**SI** Speggnere l'unità di sistema e l'unità di espansione.

Scollegare il cavo dell'unità di espansione dall'unità di sistema.

Accendere l'unità di sistema.

Continuare con la pagina successiva.

Quando si scollega l'unità di espansione, si verifica un errore 1801. Non tener conto di tale errore e continuare la prova.

**Rimane lo stesso errore?**

**NO** Richiedere assistenza tecnica per l'unità di espansione.

**SI** Richiedere assistenza tecnica per l'unità di sistema.

Se non è stato ricevuto alcuno dei messaggi di errore sopra riportati, continuare con "Sintomi di errore" nella pagina successiva.

# Sintomi di errore

Se il sistema presenta uno dei seguenti sintomi, intraprendere l'azione descritta. Se ne presenta più di uno, intraprendere l'azione descritta per il primo sintomo.

SINTOMO	AZIONE
Nessun segnale acustico	Richiedere assistenza tecnica per l'unità di sistema.
Più di un segnale acustico	Richiedere assistenza tecnica per il video.
I tasti della tastiera non funzionano	Richiedere assistenza tecnica per l'unità di sistema, la tastiera e il cavo.
Funzionano solo alcuni tasti della tastiera	Richiedere assistenza tecnica per la tastiera e il cavo.
Schermo totalmente vuoto	Continuare con "Problemi riguardanti il video".
Non appare il cursore	Richiedere assistenza tecnica per l'unità di sistema.
Appare solo il cursore	Richiedere assistenza tecnica per l'unità di sistema.
Lo schermo è illeggibile	Continuare con "Problemi riguardanti il video".
Sullo schermo mancano dei caratteri	Continuare con "Prove di sistema" nella pagina successiva.

SINTOMO	AZIONE
Sullo schermo ci sono dei caratteri sbagliati	Richiedere assistenza tecnica per l'unità di sistema.
Ampiezza di memoria errata	Richiedere assistenza tecnica per l'unità di sistema.
Appare uno schermo sbagliato	Richiedere assistenza tecnica per l'unità di sistema.

Se il sistema non presenta alcuno dei sintomi sopra riportati, continuare con "Prove di sistema" nella pagina successiva.

# Prove di sistema

Se il minidisco dei Diagnostici è già stato caricato, cominciare dal passo 6.

- 1 Spegnere l'unità di sistema.
- 2 Prendere il minidisco dei Diagnostici in fondo a questo manuale.
- 3 Caricare il minidisco nell'unità A.
- 4 Accendere l'unità di sistema.
- 5 Se appare il seguente messaggio, premere **F1** e continuare.

(RESUME="F1"KEY)

- 6 Per ogni unità installata nel sistema sarà necessario un minidisco vuoto formattato.
- Se non si riesce a formattare il minidisco, tentare con un altro. Se non si riesce a formattare neanche il secondo minidisco, richiedere assistenza tecnica per l'unità di sistema.
- 7 Selezionare **1 - FORMATTAZIONE MINIDISCO** e seguire le istruzioni sullo schermo per formattare un minidisco per **OGNI** unità minidisco.

DIAGNOSTICI del Personal Computer IBM  
Livello XXX (C)Copyright IBM Corp XXXX, XXXX

SELEZIONARE UNA SCELTA

0 - PROVA SISTEMA  
1 - FORMATTAZIONE MINIDISCO  
2 - COPIA MINIDISCO  
3 - PREPARAZ. SISTEMA PER TRASFERIMENTO  
9 - FINE DIAGNOSTICI

IMMETTERE NUMERO FUNZIONE DESIDERATA  
?

- 8 Quando appare nuovamente lo schermo sopra riportato, assicurarsi che il minidisco dei Diagnostici si trovi nell'unità A.
- 9 Selezionare **0 - PROVA SISTEMA**.

Durante la prova, possono apparire delle domande riguardanti le opzioni installate. Rispondere come richiesto.



- 12 E' apparso il seguente schermo per indicare che il sistema ha terminato la prova?

SELEZIONARE UNA SCELTA

- 0 - PROVA SISTEMA
- 1 - FORMATTAZIONE MINIDISCO
- 2 - COPIA MINIDISCO
- 3 - PREPARAZ. SISTEMA PER TRASFERIMENTO
- 9 - FINE DIAGNOSTICI

IMMETTERE NUMERO FUNZIONE DESIDERATA  
?

**SI** Se è stato annotato un messaggio di errore o ancora si sospetta l'esistenza di un problema, continuare con il passo successivo.

**NO** Richiedere assistenza tecnica per l'unità di sistema.

- 13 Cercare il sintomo nella seguente figura. Se il sistema ne presenta più di uno, intraprendere l'azione descritta per il primo sintomo.

SINTOMO	AZIONE
Messaggi di errore 3XX	Richiedere assistenza tecnica per la tastiera ed il cavo.
Errore - Unità di espansione XXXX	Richiedere assistenza tecnica per l'unità di espansione.
Problemi riguardanti il video	Continuare con "Problemi riguardanti il video" nella pagina successiva.
Messaggio di errore 432	Continuare con "Problemi riguardanti la stampatrice".
Errore o problemi riguardanti la stampatrice	Continuare con "Problemi riguardanti la stampatrice".
Le prove si interrompono e non è possibile continuare	Richiedere assistenza tecnica per l'unità di sistema.
Qualsiasi altro messaggio di errore	Richiedere assistenza tecnica per l'unità di sistema.

(X può essere un numero qualsiasi).

Se si è giunti a questo punto ed ancora si sospetta l'esistenza di qualche problema, si potrebbe voler ricercare assistenza tecnica. Una persona addestrata a dare supporto in caso di problemi tecnici specifici, come le comunicazioni, potrebbe essere disponibile presso il proprio punto di vendita.

# Problemi riguardanti il video

Assicurarsi che le manopole di controllo del video o dell'apparecchio televisivo siano regolate appropriatamente.

Se si sta usando un apparecchio televisivo, verificare che l'apparecchio lavori correttamente scollegandolo dal sistema ed usandolo normalmente.

Alcuni video dispongono di prove specifiche. Controllare le istruzioni fornite con il video per qualsiasi prova automatica che possa esservi inclusa.

## **Video Monocromatico IBM**

Se si hanno dei problemi con un video monocromatico e al momento dell'accensione dell'unità di sistema viene emesso un segnale acustico, richiedere assistenza tecnica per il video. Se si riceve qualsiasi altra risposta audio, richiedere assistenza tecnica per l'unità di sistema.

## **Video a Colori IBM**

Se si hanno dei problemi con un video a colori IBM, continuare con la pagina successiva.

- 1 Accendere l'unità di sistema.
- 2 Accendere il video.
- 3 Girare le manopole di controllo della luminosità e del contrasto completamente in senso orario.
- 4 Spegnere l'unità di sistema.

**Lo schermo è diventato bianco?**

**SI** Andare al passo 8.

**NO** Continuare con il passo successivo.

- 5 Spegnere il video.
- 6 Scollegare dal sistema il cavo dei segnali del video.
- 7 Accendere il video.

**Lo schermo è bianco?**

**SI** Richiedere assistenza tecnica per l'unità di sistema.

**NO** Richiedere assistenza tecnica per il video.

- 8 Guardando lo schermo, accendere l'unità di sistema.

**Lo schermo è cambiato da bianco a nero?**

**SI** Continuare con il passo successivo.

**NO** Richiedere assistenza tecnica per il video.

- 9 Se il video presenta uno dei sintomi seguenti, intraprendere l'azione descritta.

SINTOMO	AZIONE
Schermo vuoto	Richiedere assistenza tecnica per l'unità di sistema.
Colori sbagliati o mancanti	Richiedere assistenza tecnica per il video.

Se il sintomo non è riportato, continuare con il passo successivo.

- 10 Effettuare i controlli elencati di seguito.

- Luminosità
- Contrasto
- Stabilità verticale
- Ampiezza verticale

Se qualcuno dei controlli sopra riportati non funziona, richiedere assistenza tecnica per il video. Se tutti i controlli funzionano, continuare con il passo successivo.

11 Il problema è simile a uno degli esempi riportati di seguito?

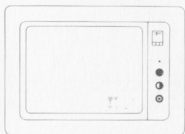

**Troppo debole**

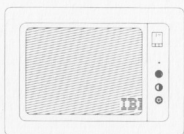

**Troppo vivo**

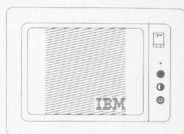

**Troppo stretto**



**Troppo largo**



**Troppo piccolo**



**Inclinato**

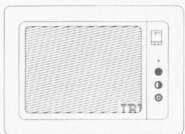

**Ruotando la  
luminosità cambia  
l'ampiezza**

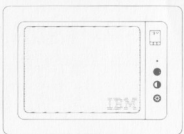

**Sfocato**

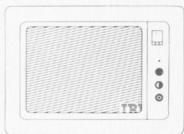

**I caratteri escono  
fuori dall'area  
del video**

**SI** Richiedere assistenza tecnica per il video.

**NO** Richiedere assistenza tecnica per l'unità di sistema.

# Problemi riguardanti la stampatrice

Fare riferimento al manuale fornito con la stampatrice ed assicurarsi che la stampatrice sia:

- Accesa
- Pronta (In Linea).

Le stampatrici potrebbero essere fornite di prove specifiche. Fare riferimento al manuale fornito con la stampatrice ed eseguire le relative prove. Se le prove riescono, richiedere assistenza tecnica per l'unità di sistema. In caso contrario, richiedere assistenza tecnica per la stampatrice ed il cavo.

# Appendice A. Mascherine di tastiera

Introduzione .....	A-2
Francese .....	A-4
Tedesco .....	A-6
Italiano .....	A-8
Spagnolo .....	A-10
Inglese U.K. ....	A-12
Inglese U.S. ....	A-14

# Introduzione

Questa sezione contiene la disposizione dei tasti (maschere) per alcune delle tastiere disponibili per il PC IBM. Vengono mostrati i caratteri dei tasti della parte superiore della tastiera e la posizione dei tasti prevista da un minidisco DOS nazionale. I caratteri aggiuntivi disponibili sono riportati nella parte posteriore di ogni maschera. Tutte le mascherine e le lingue (eccetto l'Inglese U.S.), sono per una tastiera a 102 tasti. Se vengono usate con una tastiera Inglese U.S. a 101 tasti, non tutti i caratteri saranno disponibili. Le zone più scure delle mascherine indicano i tasti non disponibili per questo tipo di tastiera (U.S.).

Se non si usa il DOS, la tastiera converte tutte le battute come se si disponesse di una tastiera modello Inglese U.S.. Come guida deve essere usata la mascherina Inglese U.S..

*Nota:* Per immettere un carattere che si trova sulla parte frontale di uno dei tasti superiori, mantenere premuto il tasto **Alt** destro e quindi premere il tasto con il carattere desiderato.

Note:

# Francese

Questa mascherina può essere riprodotta dal possessore di questo manuale per un uso proprio. Se il proprietario trasferisce questo manuale, le copie della mascherina devono essere distrutte o trasferite con il manuale.

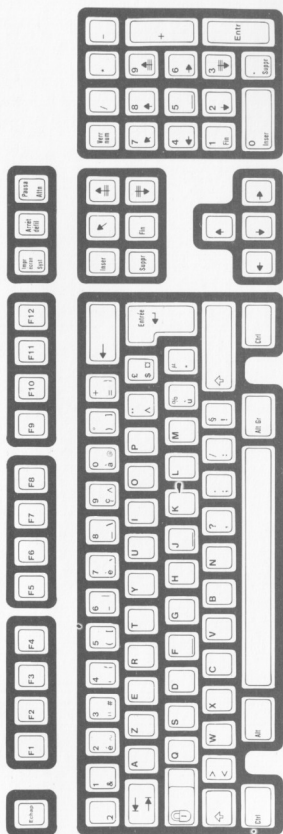

## CARACTERES SUPPLEMENTAIRES



1. Appuyez et maintenez

2. Frappez le code de trois chiffres sur le clavier numérique.



3. Relâchez

096	143	160	169	226	235	244	254
123	144	161	170	227	236	245	
124	145	162	171	228	237	246	
125	146	163	172	229	238	247	
126	149	164	173	230	239	249	
127	155	165	174	231	240	250	
128	157	166	175	232	241	251	
134	158	167	224	233	242	252	
141	159	168	225	234	243	253	

Questa tabella può essere riprodotta dal possessore di questo manuale per un uso proprio. Se il proprietario trasferisce questo manuale, le copie della mascherina devono essere distrutte o trasferite con il manuale.

# Tedesco

Questa mascherina può essere riprodotta dal possessore di questo manuale per un uso proprio. Se il proprietario trasferisce questo manuale, le copie della mascherina devono essere distrutte o trasferite con il manuale.

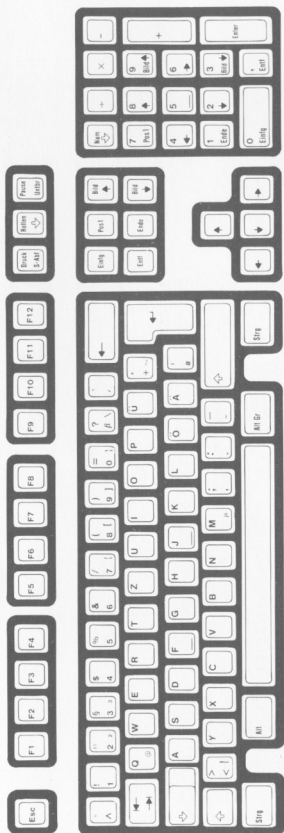

## ZUSÄTZLICHE ZEICHEN



1.

Betätigen und halten.

2. Ein 3-Zahlencode auf der Addiermaschinentastatur eingeben.



3.

loslassen.

123		136	∧	152	ÿ	167	∅	224	∞	234	Ω	243	≤	252	∧
124		139	∴	155	€	168	∫	226	∩	235	∂	244	∫	253	≥
125		140	∴	156	£	169	∩	227	∩	236	∞	245	∫	254	■
126	~	141		157	∫	170	∩	228	Σ	237	∅	246	-		
127	∩	143	A	158	Pts	171	½	229	σ	238	€	247	≈		
128	∩	145	α	159	∫ <sub>1</sub>	172	¼	230	μ	239	∩	248	°		
131	∫	146	€	164	∧	173		231	∩	240	≡	249	•		
134	∫	147	∂	165	∩	174	∩	232	∩	241	±	250	•		
135	∫	150	∂	166	±	175	∫	233	∩	242	≥	251	√		

Questa tabella può essere riprodotta dal possessore di questo manuale per un uso proprio. Se il proprietario trasferisce questo manuale, le copie della mascherina devono essere distrutte o trasferite con il manuale.

# Italiano

Questa mascherina può essere riprodotta dal possessore di questo manuale per un uso proprio. Se il proprietario trasferisce questo manuale, le copie della mascherina devono essere distrutte o trasferite con il manuale.



## CARATTERI AGGIUNTIVI



1. Premere e tenere premuto il tasto
2. Battere un codice di tre cifre sulla tastiera numerica.
3. Rilasciare il tasto



096	·	137	†	148	°	160	‡	169	⌈	226	⌋	235	∂	244	²
127	⊖	139	‡	150	⊙	161	‡	170	⌈	227	‡	236	∞	245	■
128	⊖	140	‡	152	∇	162	°	171	½	228	Σ	237	∅	246	≈
129	u	142	A	153	⊙	163	⊙	172	¼	229	σ	238	€	247	≈
131	‡	143	A	154	U	164	‡	173	‡	230	μ	239	∩	248	°
132	‡	144	E	155	€	165	N	174	⊆	231	‡	240	≡	249	•
134	‡	145	a	157	‡	166	‡	175	⌋	232	⊙	241	‡	250	•
135	⊖	146	€	158	Ph	167	°	224	≈	233	⊕	242	‡	251	√
136	‡	147	°	159	f	168	€	225	∩	234	∩	243	‡	252	n

**Questa tabella può essere riprodotta dal possessore di questo manuale per un uso proprio. Se il proprietario trasferisce questo manuale, le copie della mascherina devono essere distrutte o trasferite con il manuale.**

# Spagnolo

Questa mascherina può essere riprodotta dal possessore di questo manuale per un uso proprio. Se il proprietario trasferisce questo manuale, le copie della mascherina devono essere distrutte o trasferite con il manuale.

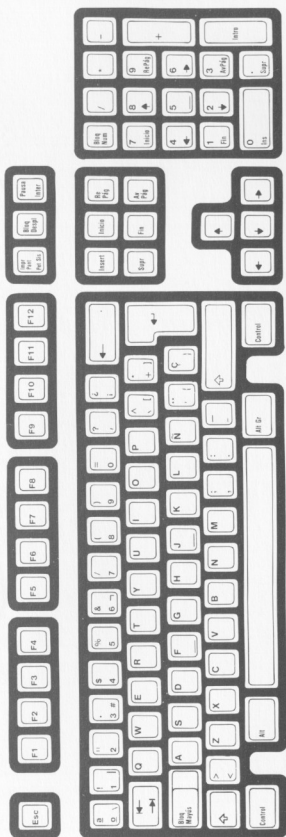

## CARACTERES ADICIONALES



1. Pulse y mantenga pulsada la tecla
2. Teclee un código de 3 dígitos en el teclado numérico (Lado derecho del teclado)



3. Libere

123	156 £	172 ¼	230 μ	239 ∩	248 °
124	157 ₤	174 ⋈	231 τ	240 ≡	249 •
125	158 ₣	175 }⋈	232 ⚡	241 ±	250 •
126 ~	159 /	224 ∞	233 ⚡	242 >	251 √
127 ∅	166 ½	225 ∩	234 Ω	243 ≤	252 ∞
134 ½	167 ¾	226 ∩	235 ⚡	244 }	253 ∞
145 α	169 ∩	227 π	236 ∞	245 }	254 ■
146 ₤	170 ∩	228 ∞	237 ∅	246 +	
155 €	171 ½	229 σ	238 €	247 //	

Esta tabla può essere riprodotta dal possessore di questo manuale per un uso proprio. Se il proprietario trasferisce questo manuale, le copie della mascherina devono essere distrutte o trasferite con il manuale.

# Inglese U.K.

Questa mascherina può essere riprodotta dal possessore di questo manuale per un uso proprio. Se il proprietario trasferisce questo manuale, le copie della mascherina devono essere distrutte o trasferite con il manuale.



### ADDITIONAL CHARACTERS

127	136	145	154	163	172	172	228	239	248
128	137	146	155	164	173	173	229	240	249
129	138	147	156	165	174	174	230	241	250
130	139	148	157	166	175	175	231	242	251
131	140	149	158	167	176	176	232	243	252
132	141	150	159	168	177	177	233	244	253
133	142	151	160	169	178	178	234	245	254
134	143	152	161	170	179	179	235	246	255
135	144	153	162	171	180	180	236	247	



1. Press and hold

2. Type 3-digit code on numeric keypad.



3. Release

Questa tabella può essere riprodotta dal possessore di questo manuale per un uso proprio. Se il proprietario trasferisce questo manuale, le copie della mascherina devono essere distrutte o trasferite con il manuale.

# Inglese U.S.

Questa mascherina può essere riprodotta dal possessore di questo manuale per un uso proprio. Se il proprietario trasferisce questo manuale, le copie della mascherina devono essere distrutte o trasferite con il manuale.



### ADDITIONAL CHARACTERS



1. Press and hold

2. Type 3-digit code on numeric keypad.



3. Release

096	135	144	153	163	172	229	238	247
127	136	145	154	164	173	230	239	248
128	137	146	155	165	174	231	240	249
129	138	147	157	166	175	232	241	250
130	139	148	158	167	224	233	242	251
131	140	149	159	168	225	234	243	252
132	141	150	160	169	226	235	244	253
133	142	151	161	170	227	236	245	254
134	143	152	162	171	228	237	246	

**Questa tabella può essere riprodotta dal possessore di questo manuale per un uso proprio. Se il proprietario trasferisce questo manuale, le copie della mascherina devono essere distrutte o trasferite con il manuale.**

Note:

## Appendice B. Numeri di serie

Riportare in questa sezione i numeri di serie riguardanti l'hardware.

Unità di sistema	
Video monocromatico	
Video a colori	
Stampatrice	

Note:

# Glossario

Questo glossario include termini e definizioni estratte dall'*IBM Vocabulary for Data Processing, Telecommunications, and Office Systems*, GC20-1699.

**adattatore.** (1) Scheda con un circuito stampato che si inserisce nella scheda di sistema consentendo il collegamento all'unità di sistema di un'opzione esterna. (2) Qualsiasi scheda con un circuito stampato che si inserisca nella scheda di sistema.

**avviamento.** Preparazione del sistema per le normali operazioni.

**BASIC.** (1) Beginner's all-purpose symbolic instruction code. (2) Linguaggio di programmazione che usa parole inglesi comuni.

**caricare.** In programmazione, immissione di dati in memoria o nei registri di lavoro.

**configurazione.** Unità e programmi che formano un sistema, un sottosistema o una rete.

**controllo di parità.** (1) Controllo ridondante che usa un bit di parità. (2) Sinonimo di controllo pari-dispari.

**copia di riserva.** Duplicazione dei dati di un'unità a disco fisso o di un minidisco su un minidisco che assicura la disponibilità dei dati anche in caso di perdita o danno dell'originale.

**corrente.** Velocità con la quale scorrono i carichi elettrici.

**cursore.** (1) Nei grafici di sistema, un trattino mobile che viene usato per indicare una posizione sul video. (2) Simbolo visualizzato che si comporta come un trattino per aiutare l'utente a localizzare un punto nel testo, in un comando di sistema o in memoria. (3) Una lineetta luminosa mobile sullo schermo di un'unità video, che di solito indica dove il carattere successivo deve essere immesso, sostituito o cancellato.

**dati.** (1) Rappresentazione di fatti, concetti o istruzioni in un formato compatibile per la comunicazione, l'interpretazione o l'elaborazione da parte dell'uomo o da parte di mezzi automatici.

**disco flessibile.** Sinonimo di minidisco.

**DOS.** Vedere sistema operativo.

**eseguire.** Esecuzione singola continua di un programma o routine.

**FCC.** Federal Communication Commission.

**file.** (1) Gruppo di record correlati come un file di dati. (2) Memorizzare dati sotto forma di file, in modo che possano essere richiamati.

**formattare.** Preparare un minidisco per ricevere dati in modo organizzato.

**hardware.** (1) Apparato fisico usato nell'elaborazione dati, diverso da programmi, procedure, regole e documentazione associata. (2) Opposto a software.

**K.** 1024 byte.

**KB.** 1024 byte.

**linguaggio di programmazione.** (1) Linguaggio artificiale stabilito per esprimere programmi. (2) Serie di caratteri e regole, con un significato assegnato prima del loro uso, per scrivere programmi.

**M.** 1.048.576 byte.

**MB.** 1.048.576 byte.

**memoria.** (1) Unità di memoria. (2) Unità o parte di unità che può mantenere dati. (3) Minidisco. (4) Unità a disco fisso.

**memoria di sistema.** Termine per la memoria principale.

**memorizzare.** Porre i dati in un'unità di memoria. (2) Mantenere i dati in un'unità di memoria.

**minidisco.** Un disco magnetico sottile e flessibile ed un involucro protettivo semirigido, nel quale il disco è racchiuso permanentemente. Sinonimo di disco flessibile.

**minidisco a doppia faccia.** Disco sottile e flessibile trattato magneticamente per memorizzare i dati su entrambe le facce.

**minidisco a singola faccia.** Disco sottile e flessibile trattato magneticamente per memorizzare i dati solo su una faccia.

**minidisco dei Diagnostici.** Minidisco con programmi disegnati per individuare ed isolare le parti guaste del sistema.

**opzione esterna.** Unità collegate alla parte esterna dell'unità di sistema che ne estendono e ne migliorano l'operatività. Esempi: video, stampatrice o modem.

**opzione interna.** Parti installate all'interno del coperchio dell'unità di sistema che migliorano l'operatività del sistema, come per esempio gli adattatori e le opzioni di memoria.

**personal computer.** Un elaboratore per uso domestico o di ufficio che comprende un processore ed una tastiera e che può essere collegato ad un apparecchio televisivo o ad un altro schermo tester.

**programma.** (1) Serie di azioni disegnate per raggiungere un certo risultato. (2) Serie di istruzioni che indica al sistema come gestire un problema o una funzione. (3) Disegnare, scrivere e provare i programmi di sistema.

**programma di sistema.** Sequenza di istruzioni adatta per essere elaborata da un sistema.

**ripetitivo.** Tasto che ripete la funzione se mantenuto premuto.

**schermo tester.** Sinonimo di video con tubo a raggi catodici (video CRT).

**scrivere.** Fare una registrazione permanente o momentanea dei dati in una unità di memoria o in un supporto dati.

**sistema.** Configurazione di sistema che comprende almeno un'unità di sistema, una tastiera ed un video.

**sistema operativo.** Software che controlla l'esecuzione dei programmi; un sistema operativo può fornire dei servizi, come allocazione risorse, schedulazione, controllo di immissione/emissione e gestione dei dati.

**sistema PC.** Unità funzionale che può eseguire calcoli complessi, comprese numerose operazioni aritmetiche o logiche, senza intervento dell'uomo durante l'esecuzione.

**software.** (1) Programmi di sistema, procedure e regole riguardanti le operazioni di un sistema di elaborazione dati. (2) Opposto a hardware.

**unità.** Parte elettronica di un apparato con uno scopo specifico.

**unità a disco fisso.** Nel PC IBM, unità consistente di dischi magnetici non rimovibili e un'unità per memorizzare e recuperare i dati dai dischi.

**unità di sistema.** Parte principale della configurazione del sistema.

**unità minidisco.** Unità per memorizzare e recuperare i dati da un minidisco.

**video.** Unità per la presentazione visuale di informazioni su qualsiasi unità per la visualizzazione di caratteri temporanei.

**video monocromatico.** Video sul quale i dati appaiono in un unico colore.

# Indice analitico

## A

- a proposito dei minidischi 3-14
- Adattatore colore/grafici  
IBM 4-11
- Adattatore grafici avanzati  
IBM 4-11
- Adattatore monocromatico e  
stampatrice IBM 4-11
- area dei tasti di controllo 3-10
- area dei tasti funzionali 3-9
- area della tastierina  
numerica 3-9

## B

- BASIC 3-7

## C

- caricamento dell'unità  
minidisco 3-16
- cavo del video 2-6
- collegamento dell'unità di  
sistema 2-3
- coperchio  
installazione 4-13  
rimozione 4-5

## D

- disco fisso  
unità 3-17

## H

- hardware 1-2

## I

- IBM BASIC 3-7
- identificatore della tastierina  
numerica 3-10
- identificatori di inizio riga 3-8
- indicatore  
accensione 3-18  
stato 3-8  
utilizzo 3-16
- indicatore di accensione 3-18
- interruttore di accensione 2-5
- interruttori della scheda di  
sistema 4-8

## L

- luce di segnalazione di  
utilizzo 3-16

## M

- mascherine  
Francese A-4  
Inglese U.K. A-12  
Inglese U.S. A-14  
Italiano A-8  
Spagnolo A-10  
Tedesco A-6
- mascherine delle tastiere A-2
- minidischi 3-14
- minidisco  
caricamento 3-16  
inserimento 3-16  
protetto da scrittura 3-15

rimozione 3-16  
Viaggio nel Personal  
Computer XT IBM 3-3

## N

numeri di serie B-1  
unità di sistema 2-4

## O

opzione  
esterna 1-1, 4-15  
installazione 4-3, 4-16  
interna 1-1, 2-1, 4-3  
opzione esterna 1-1  
opzione interna 1-1, 4-3

## P

preparazione al trasferimento del  
sistema 3-19  
programma 1-3, 3-7  
protetto da scrittura 3-15

## R

rimozione minidisco 3-16  
ripetitivo 3-8  
riportare numeri di serie  
unità di sistema 2-4

## S

sicurezza elettrica v  
sistema  
completo 1-1  
lista di controllo 2-3  
unità 3-7  
sistema, lista di controllo 2-3

software 1-3  
stampatrice  
collegamento 2-7

## T

tasti di controllo del  
cursore 3-10  
tastiera  
area dattilografica 3-8  
area dei tasti di  
controllo 3-10  
area dei tasti funzionali 3-9  
area della tastierina  
numerica 3-9  
mascherine A-2  
regolazione altezza 3-12  
tastiera 3-8  
tastiere, mascherine  
Francese A-4  
Inglese U.K. A-12  
Inglese U.S. A-14  
Italiano A-8  
Spagnolo A-10  
Tedesco A-6  
tasto BlocNum 3-9  
trasferimento del PC XT IBM  
nuova sede 3-23  
preparazione al trasferimento  
del sistema 3-19  
trasferimento a lungo  
raggio 3-23  
trasferimento del sistema 3-19

## U

unità  
a disco fisso 3-17  
unità di sistema  
indicatore di accensione 3-18  
unità minidisco  
luce di segnalazione di  
utilizzo 3-16  
operazioni 3-14



Viaggio nel Personal Computer

XT IBM 3-3

video

a colori 3-18, 5-20

contrasto 5-22

controlli 5-22

luminosità 5-22  
monocromatico 3-18, 5-20  
video a colori 3-18  
video monocromatico 3-18

Note:



IBM United Kingdom  
International Products Limited  
PO Box 41, North-Harbour  
Portsmouth, PO6 3AU  
England

Printed in Great Britain by Ben Johnson & Co. Ltd., York.

**IBM**

# PROBLEM DETERMINATION PROCEDURES

## Introduction

If you experience a problem with either your IBM Personal Computer or IBM Personal Computer XT, the problem determination procedures will help you find which unit in your system is failing. The procedures also can be used to check that your system is operating correctly. Simply follow the step-by-step instructions and answer yes or no to the questions asked.

As part of the problem determination, you may have to use the Diagnostics diskette, which is at the back of the manual. The diskette has a series of tests that check the five units of your system—system unit, expansion unit, keyboard, display, and printer—as well as other installed options. The tests are performed in sequence. As one test finishes successfully, the next one automatically starts.

**Note:** If you have a non-U.S. English keyboard and use the diskette in the back of this manual, use a U.S. English keyboard template.

For a screen-alignment problem, start on the following page. To do a complete system check or find the cause of a problem, start with “Checking Electrical Connections” on page Start 20-1.

### Other Options

Some options may have separate manuals. For a description of problem diagnosis, go to that option's manual.



# Screen Alignment Procedure

- 1 Remove the Diagnostics diskette from the back of this manual.

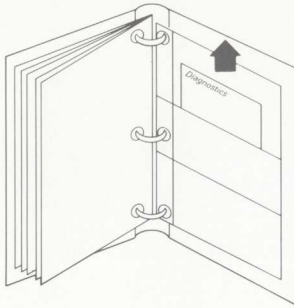

- 2 Set the Power switch on the system unit (and expansion unit, if attached) to Off.

| Is the International symbol for On.

O Is the International symbol for Off.

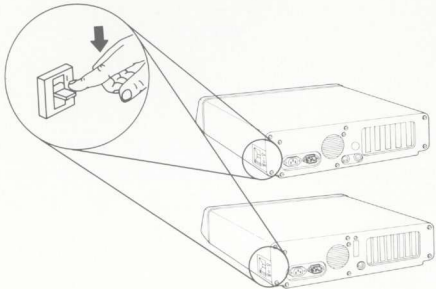

- 3 Set the Power switches on all attached devices to Off.
- 4 Lift the diskette-drive load lever.
- 5 Insert the Diagnostics diskette into drive A.

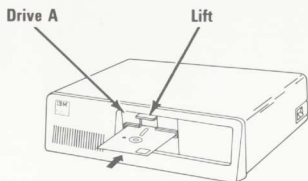

- 6 Push the load lever down.

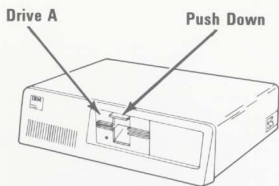

- 7 Set the Power switches on all attached devices to On.
- 8 If an expansion unit is attached, set its Power switch to On.
- 9 Set the system unit's Power switch to On.

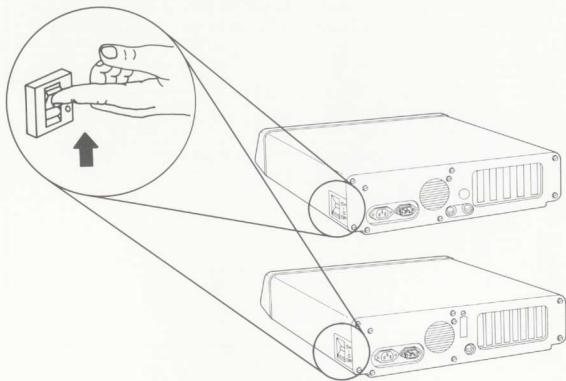

If you are using your TV or a non-IBM display with your system, and its screen image is similar to the one below, do the step following the figure to correct the problem.



**Note:** If the alignment on any IBM display is incorrect, have it serviced.

IBM Personal Computer DIAGNOSTICS  
Version XXX (C) Copyright IBM Corp XXXX

SELECT AN OPTION

- RUN DIAGNOSTIC ROUTINES
- FORMAT DISKETTE
- COPY DISKETTE
- PREPARE SYSTEM FOR RELOCATION
- EXIT TO SYSTEM DISKETTE

ENTER THE ACTION DESIRED

**10** Press function key  to move the presentation to the right, or  to move the presentation to the left, as appropriate.

Your screen should match the one shown in the figure below. If it does, remove the Diagnostics diskette and return it to the back of the manual. If not, have your TV or non-IBM display serviced.

**The IBM Personal Computer DIAGNOSTICS  
Version XXX (C) Copyright IBM Corp XXXX, XXXX**

**SELECT AN OPTION**

**0 - RUN DIAGNOSTIC ROUTINES**

**1 - FORMAT DISKETTE**

**2 - COPY DISKETTE**

**3 - PREPARE SYSTEM FOR RELOCATION**

**9 - EXIT TO SYSTEM DISKETTE**

**ENTER THE ACTION DESIRED**

**?**

Continue with the next Test.



# Checking Electrical Connections

- 1** Set the Power switch on the system unit (and expansion unit, if attached) to Off.
- 2** Set the Power switches on all attached devices to Off.
- 3** Disconnect all devices.
- 4** Unplug the system unit's (and expansion unit's) power cord from the wall outlet.

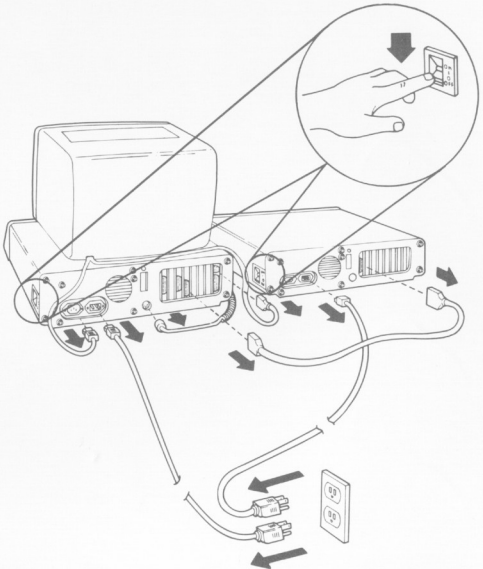

- 5 Check the wall outlet by plugging in a working lamp.



Outlet O.K.

- 6 Connect each cable to the proper connector on the system unit (and expansion unit, if attached) to ensure correct electrical connection.
- 7 Plug the system unit's (and expansion unit's) power cord into the wall outlet.

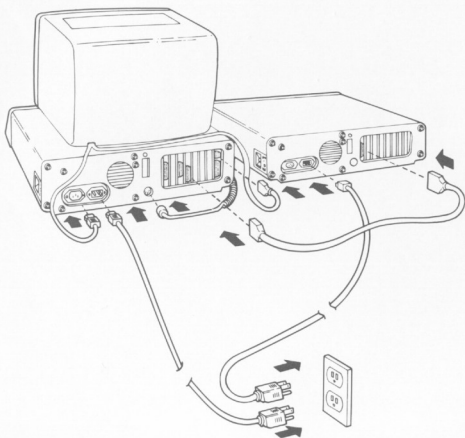

**Note:** If you do not have an IBM Communications Adapter Cable attached to your system unit, go to the next page.

**8** If you have an IBM Communications Adapter Cable, it came with a wrap plug. Disconnect the Communications Adapter Cable at the modem end (refer to the Communications Adapter Cable's "Option Installation Instructions" for the cable-removal procedure).

**9** See the figure below and install the wrap plug (IBM part number 8529280) on the modem end of the cable (end farthest from the system unit).

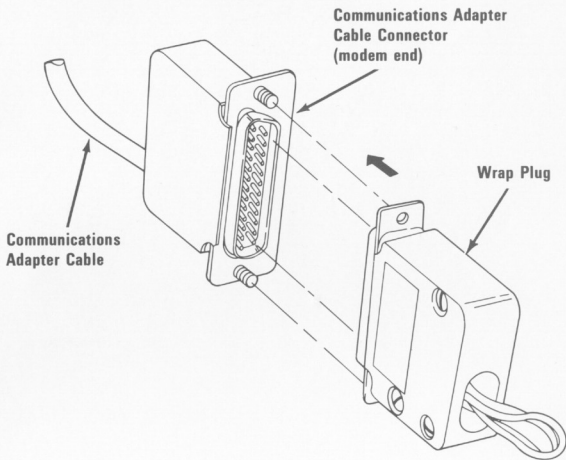

**Note:** If you do not have an IBM Cluster Adapter, continue with “Power-On Self Test (POST)” on the following page.

**10** If you have an IBM Cluster Adapter, it came with a terminating plug. Disconnect the coaxial cable from the Cluster Adapter’s connector.

**11** Refer to the figure below and install the terminating plug (IBM part number 6323481) on the Cluster Adapter’s connector.

Continue with “Power-On Self Test (POST)” on the following page.

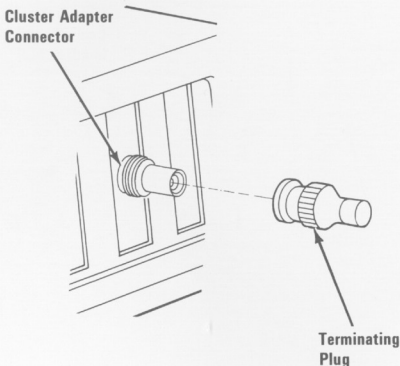

# Power-On Self Test (POST)

- 1 Turn the Brightness and Contrast controls fully clockwise. When the first screen presentation appears, adjust the controls for eye comfort.

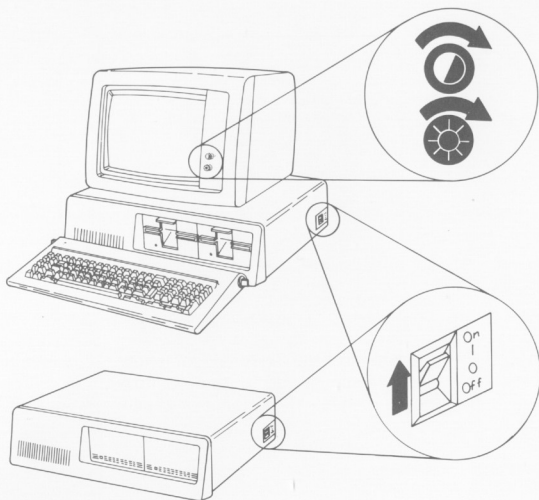

- 2 Set the Power switches on all attached devices to On.
- 3 If the expansion unit is attached, set its Power switch to On.
- 4 Set the system unit's Power switch to On.

POST will finish in 13 to 90 seconds, depending on the amount of memory in your system. Normally, you will receive the following responses:

- A Look in the upper left-hand corner of the screen during POST.

If you have the Personal Computer, a blinking cursor should appear.

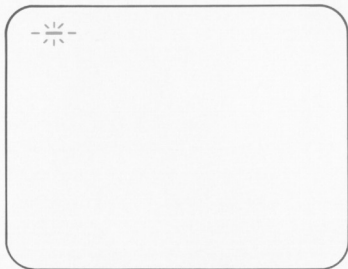

If you have the Personal Computer XT, a number should appear and continue to increase in value until it equals the amount of memory in your system.

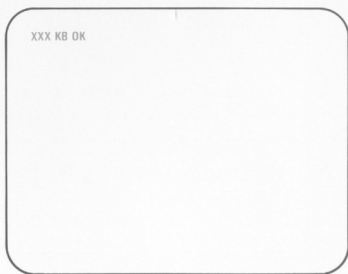

- B One short beep will be heard when the test finishes successfully.
- C The "IBM Personal Computer BASIC" message should appear. (If, at the end of POST, a program from a diskette, or an operating system from the fixed disk drive, is automatically loaded, the first screen presentation of the program or operating system should appear).

The IBM Personal Computer Basic  
Version CX.XX Copyright IBM Corp. XXXX  
XXXXX Bytes free  
Ok

1LIST 2RUN 3LOAD" 4SAVE 5CONT 6LPT1 '7TRON 8TROFF 9KEY 0SCREEN

Did A, B, and C occur?

**YES** - Go to "Formatting a Diskette" on page Start 40-1.

**NO** - Personal Computer users go to "Personal Computer POST Errors" on the next page.

Personal Computer XT users go to "Personal Computer XT POST Errors" on Start 30-8.

## Personal Computer POST Errors

In the following examples, find your screen response and audio response, then follow the instructions in the box marked "Action."

**Warning:** If the instructions are to have a unit serviced, and that unit has a fixed disk drive, we recommend that you back up all disk files onto diskettes. Normal shipping and handling can result in permanent loss of data on your fixed disk drives. Refer to the IBM *DOS* manual for a description of the Backup command.

## Example 1

### Screen Response

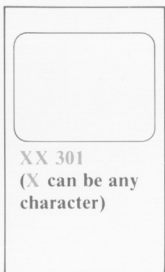

### Audio Response

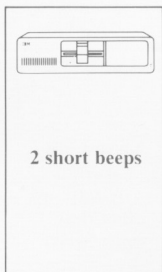

### Action



**Note:** Ensure the keyboard is connected correctly and check for any objects or foreign material on the keyboard. If error 301 still appears after the keyboard has been serviced, have the system unit serviced.

## Example 2

### Screen Response



### Audio Response

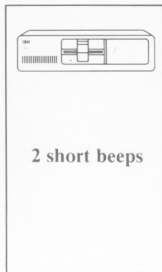

### Action

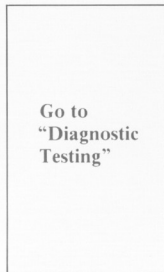

### Example 3

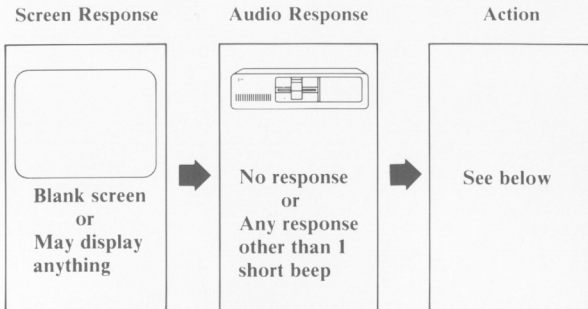

Do you have an expansion unit attached?

**NO** - Have the system unit serviced.

**YES** - Do the following:

1. Set the Power switches on the system unit and expansion unit to Off.
2. Set the Power switches on all attached devices to Off.
3. Disconnect the expansion unit cable from the system unit.
4. Set the Power switch on the system unit to On.

If the error is the same, have the system unit serviced.  
If the error changes, have the expansion unit and its cable serviced.

#### Example 4 (Color Display Only)

##### Screen Response

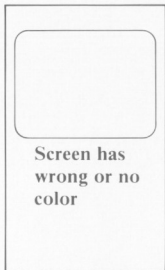

##### Audio Response

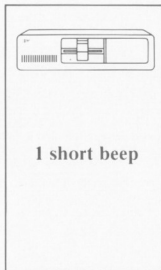

##### Action

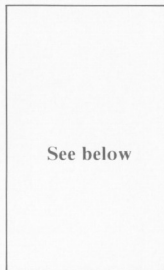

If you are using a TV as your display, verify that the color is correct by disconnecting your TV from the unit and operating the TV normally. Also, ensure your TV is compatible with the NTSC standard. If you have an IBM Color Display, go to Test 9000.

#### Example 5

##### Screen Response

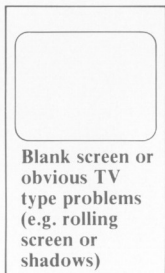

##### Audio Response

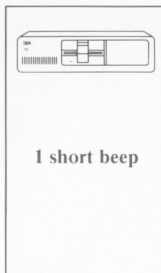

##### Action

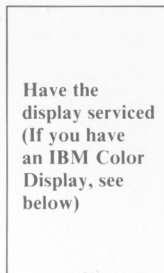

If you have an IBM Color Display, go to Test 9000.

# Personal Computer XT POST Errors

In the following examples, find your screen response and audio response, then follow the instructions in the box marked "Action."

**Warning:** If the instructions are to have a unit serviced, and that unit has a fixed disk drive, we recommend that you back up all disk files onto diskettes. Normal shipping and handling can result in permanent loss of data on your fixed disk drives. Refer to the IBM *DOS* manual for a description of the Backup command.

## Example 1

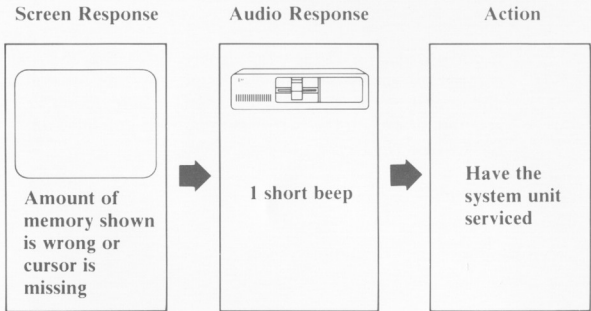

## Example 2

### Screen Response



### Audio Response

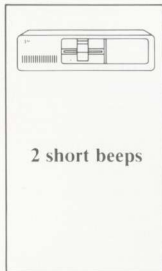

### Action



**Note:** Ensure the keyboard is connected correctly and check for any objects or foreign material on the keyboard. If error 301 still appears after the keyboard has been serviced, have the system unit serviced.

## Example 3

### Screen Response



### Audio Response

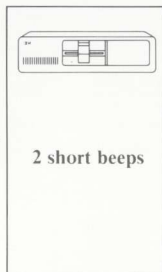

### Action

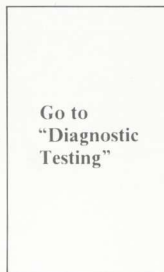

## Example 4

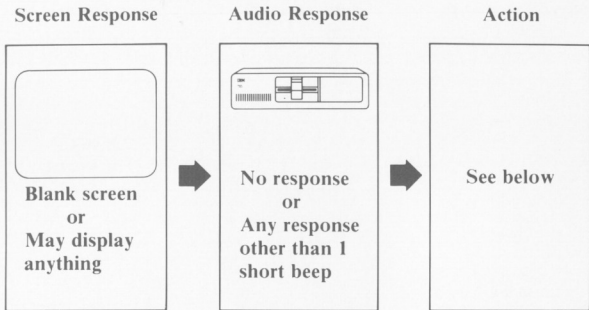

Do you have an expansion unit attached?

**NO** - Have the system unit serviced.

**YES** - Do the following:

1. Set the Power switches on the system unit and expansion unit to Off.
2. Set the Power switches on all attached devices to Off.
3. Disconnect the expansion-unit cable from the system unit.
4. Set the Power switch on the system unit to On.

If the error is the same, have the system unit serviced.  
If the error changes, have the expansion unit and its cable serviced.

### Example 5 (Color Display Only)

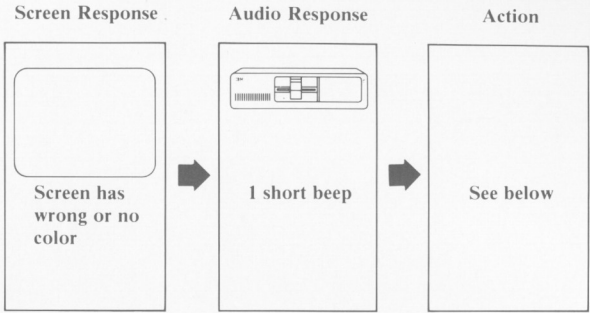

If you are using a TV as your display, verify that the color is correct by disconnecting your TV from the unit and operating the TV normally. Also, ensure your TV is compatible with NTSC standard. If you have an IBM Color Display, go to Test 9000.

### Example 6

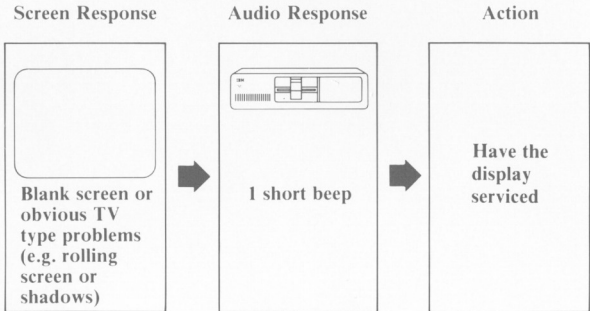

If you have an IBM Color Display, go to Test 9000.



# Formatting a Diskette

During the diagnostic tests that follow, you will need a scratch diskette (a *scratch* diskette is a formatted diskette with no data on it). If you already have a scratch diskette, skip this section and proceed to Diagnostic Testing on page Test 000-1. If you do not have a scratch diskette, continue with this procedure.

- 1 Remove the Diagnostics diskette from the back of this manual.

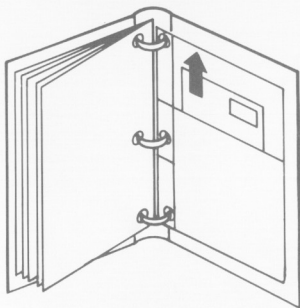

- 2 Set the Power switch on the system unit (and expansion unit, if attached) to Off.

- 3 Set the Power switches on all attached devices to Off.
- 4 Lift the diskette drive's load lever and insert the Diagnostics diskette into drive A.
- 5 Push the load lever down.

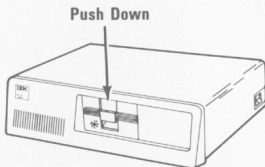

If you have trouble inserting your diskette, turn to the operating section of your *Guide to Operations* for more information.

- 6 Set the Power switches on all attached devices to On.
- 7 If an expansion unit is attached, set its Power switch to On.
- 8 Set the Power switch on the system unit to On.

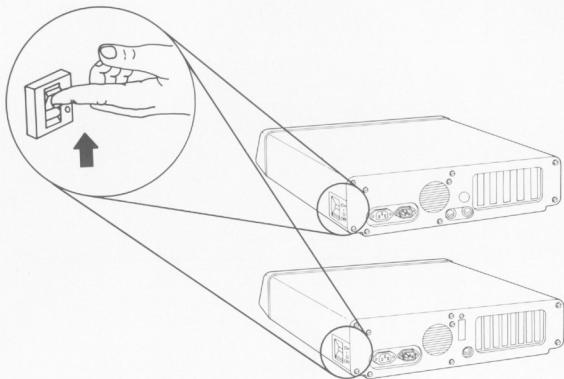

9

Did the following appear on your screen?

(X can be any character.)

```
XXXX
XXX KB OK
ERROR. (RESUME="F1" KEY)
```

YES - Press  , then go to the next step.

NO - Go to the next step.

**10** Did the following appear on your screen?

THE IBM PERSONAL COMPUTER DIAGNOSTICS  
VERSION XXX (C) COPYRIGHT IBM CORP XXXX

SELECT AN OPTION

0 - RUN DIAGNOSTIC ROUTINES

1 - FORMAT DISKETTE

2 - COPY DISKETTE

3 - PREPARE SYSTEM FOR RELOCATION

9 - EXIT TO SYSTEM DISKETTE

ENTER THE ACTION DESIRED

?

**YES** - Go to the next step.

**NO** - Remove the diskette and verify that it:

- Is the Diagnostics diskette.
- Was inserted correctly.

If the Diagnostics diskette was inserted correctly, have the system unit serviced.

**11** Press  to select **FORMAT DISKETTE**,

then

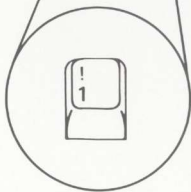

Go to the next step.

**12** Did the following appear on your screen?

The IBM Personal Computer DIAGNOSTICS  
Version XXX (C) Copyright IBM Corp XXXX, XXXX

SELECT AN OPTION

0 - RUN DIAGNOSTIC ROUTINES

1 - FORMAT DISKETTE

2 - COPY DISKETTE



3 - PREPARE SYSTEM FOR RELOCATION

9 - EXIT TO SYSTEM DISKETTE

ENTER THE ACTION DESIRED

? 1

WHICH DRIVE CONTAINS DISKETTE  
TO BE FORMATTED?

YES - Press  then  and go to the  
next step.

NO - Have your system unit serviced.

**13** Did the following appear on your screen?

The IBM Personal Computer DIAGNOSTICS  
Version XXX (C) Copyright IBM Corp XXXX

SELECT AN OPTION

0 - RUN DIAGNOSTIC ROUTINES

1 - FORMAT DISKETTE

2 - COPY DISKETTE

3 - PREPARE SYSTEM FOR RELOCATION

9 - EXIT TO SYSTEM DISKETTE

ENTER THE ACTION DESIRED

? 1

WHICH DRIVE CONTAINS DISKETTE  
TO BE FORMATTED? A

INSERT DISKETTE TO BE FORMATTED  
IN DRIVE A:

PRESS ENTER WHEN READY

**YES** - Remove the Diagnostics diskette from drive A, insert a blank diskette push the load lever down.

Press  and go to the next step.

**NO** - Have your system unit serviced.

**14** The blank diskette will be formatted. When the In-Use light goes out, remove the scratch diskette and go to the next step.

- 15 Did the following appear on your screen after the diskette was formatted?

**SELECT AN OPTION**

**0 - RUN DIAGNOSTIC ROUTINES**

**1 - FORMAT DISKETTE**

**2 - COPY DISKETTE**

**3 - PREPARE SYSTEM FOR RELOCATION**

**9 - EXIT TO SYSTEM DISKETTE**

**ENTER THE ACTION DESIRED**

**? - ☼ -**

**YES -** Continue with “Diagnostic Testing” on page Test 000-1.

**NO -** Return to Step 10 and try another blank diskette. Be sure you insert the diskette correctly. If the problem still exists, have the system unit serviced.



# Diagnostic Testing

During the diagnostic tests that follow, you will need a scratch diskette. If you do not have a scratch diskette, go to "Diskette Format Procedure" on page Start 40-1.

During the diagnostic tests, you may be asked to record an error message. This information is needed when you have your system serviced.

Following are examples of error messages you may receive. A message ending in **00** means the test finished successfully.

In the examples, X can be any character.

## Example 1

```
XX:XX:XX  
ERROR - SYSTEM UNIT  XXXX
```

## Example 2

```
XX:XX:XX  
ERROR - EXPANSION UNIT  XXXX
```

The unit in which your options are installed determines if the error message reads **SYSTEM UNIT** or **EXPANSION UNIT**.

### Example 3

```
XX:XX:XX  
XXX KB OK  
ERROR. (RESUME="F1"KEY)
```

**Warning:** If the above message appears on your screen, it means the POST detected an error. The message also will appear if you have an expansion unit that is not connected to your system or that does not have its Power switch set to On.

Pressing the F1 key allows the system to bypass the error condition for the diagnostic tests, but your system may not function correctly unless it is serviced.

Continue with "Loading Diagnostics" on the next page.

# Loading Diagnostics

- 1 Remove the Diagnostics diskette from the back of this manual.

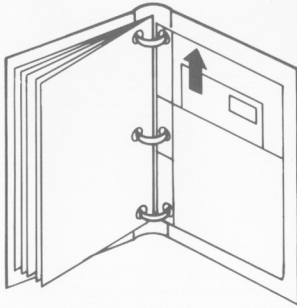

- 2 Set the Power switch on the system unit (and expansion unit, if attached) to Off.
- 3 Set the Power switches on all attached devices to Off.

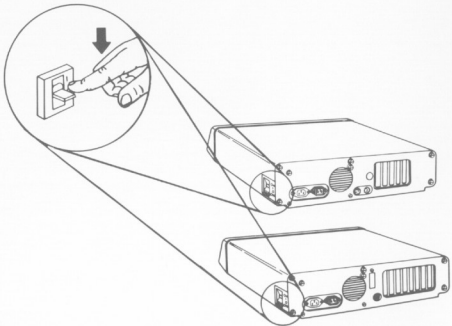

- 4 Raise the diskette drive's load lever and insert the Diagnostics diskette into drive A.
- 5 Push the load lever down.

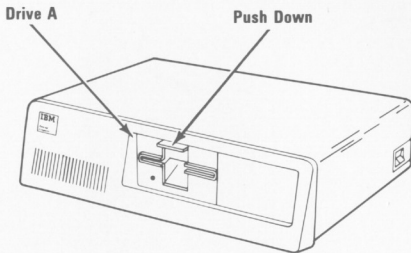

If you have trouble inserting your diskette, turn to the operating section of your *Guide to Operations* for more information.

- 6 Set the Power switches on all attached devices to On.
- 7 If an expansion unit is attached, set its Power switch to On.
- 8 Set the Power switch on the system unit to On.

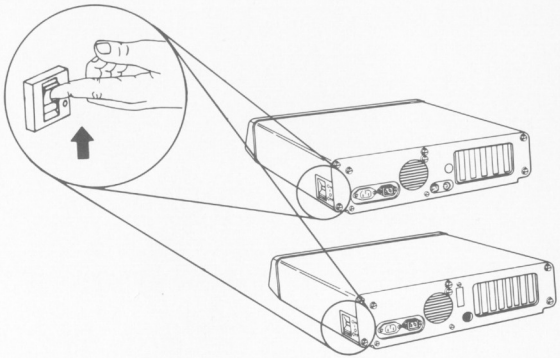

9

Did the following appear on your screen?

XXXX  
XXX KB OK  
ERROR. (RESUME= "F1" KEY)

YES - Press  , then go to the next step.

NO - Go to the next step.

**10** Did the following appear on your screen?

The IBM Personal Computer **DIAGNOSTICS**  
Version XXX (C) Copyright IBM Corp XXXX, XXXX

**SELECT AN OPTION**

**0 - RUN DIAGNOSTIC ROUTINES**

**1 - FORMAT DISKETTE**

**2 - COPY DISKETTE**

**3 - PREPARE SYSTEM FOR RELOCATION**

**9 - EXIT TO SYSTEM DISKETTE**

**ENTER THE ACTION DESIRED**

**?**



**YES** - Go to the next step.

**NO** - Remove the diskette and verify that it:

- Is the Diagnostics diskette.
- Was inserted correctly.

If the Diagnostics diskette was inserted correctly, have the system unit serviced.

**Note:** If you are using your TV or a non-IBM display, you could experience data errors when you operate your diskette drive. To correct this problem, move your TV or display a minimum of 30 cm (12 in.) away from your system unit.

11 Press  , then  to select

**RUN DIAGNOSTIC ROUTINES.**

The IBM Personal Computer DIAGNOSTICS  
Version XXX (C) Copyright IBM Corp XXXX

**SELECT AN OPTION**

**0 - RUN DIAGNOSTIC ROUTINES**

**1 - FORMAT DISKETTE**

**2 - COPY DISKETTE**

**3 - PREPARE SYSTEM FOR RELOCATION**

**9 - EXIT TO SYSTEM DISKETTE**

**ENTER THE ACTION DESIRED**

**?**

**Note:** Depending on the configuration of your system, questions about attached devices may appear on your screen.

Press  or  as required,

then press  .

- 12** Complete the list of installed devices and options and show their locations with check marks. Also enter the amount of memory you have in your system. Then go to the next step.

System Unit	Expansion Unit	Installed Device/Option
		System Board
		Expansion Option
		XXX KB of Memory
		Keyboard
		Monochrome and Printer Adapter
		X Diskette Drive(s) and Adapter
		Math Coprocessor
		X Fixed Disk Drive(s) and Adapter
		Asynchronous Communications Adapter



**Installed Devices, Options, and Memory**



In the following sample, **S** means the device or option is installed in the system unit, and **E** means it is installed in the expansion unit.

- 13 Does the screen presentation correctly list all the installed devices and options?



**Note:** The IBM Communications Cable and the Printer Cable will not appear in the list, and the Graphics Printer will be listed as "Matrix Printer." The Game Control Adapter may not be listed if the joysticks or paddles are not connected when the Power switch is set to On.

**YES** - Press  then  and go to the next step.

**NO** - Press  then , and record the error message. If your printer was not

listed, press  and go to the next

step. If any other device or option was not listed, have the unit that contains that option serviced.

14 Press  to select **RUN TESTS ONE TIME**,

then



#### SYSTEM CHECKOUT

- 0 - RUN TESTS ONE TIME
- 1 - RUN TESTS MULTIPLE TIMES
- 2 - LOG UTILITIES
- 9 - EXIT DIAGNOSTIC ROUTINES

ENTER THE ACTION DESIRED

?

The diagnostic programs have successfully loaded. Continue with the tests on the following pages to perform a complete system checkout.



# Test 100

Did you receive a **SYSTEM UNIT 100** message, as shown below?

**SYSTEM UNIT      100**  
**THIS TEST TAKES UP TO TWO MINUTES**  
**PLEASE STAND BY**

**YES -** Your system has completed this test successfully. Continue with the next Test.

**NO -** Have the system unit serviced.



# Test 200

1 Do you have an IBM Expansion Unit attached to your system?

NO - Continue with the next Test.

YES - Did you receive an **SYSTEM UNIT 1800** message, as shown below?

<b>SYSTEM UNIT</b>	<b>100</b>
<b>SYSTEM UNIT</b>	<b>1800</b>

**THIS TEST TAKES UP TO TWO MINUTES  
PLEASE STAND BY**

YES - Your system has completed this test successfully. Continue with the next test, Test 300.

NO - Go to the next step.

**2**

Did you receive an **1819** error message, as shown below?

```
SYSTEM UNIT      100  
  
XX:XX:XX  
ERROR EXPANSION UNIT      1819  
  
PRESS ENTER TO CONTINUE  
?
```

**YES** - Have the expansion unit and its cable serviced.

**NO** - Go to the next step.

**3** Did you receive an **1820** or **1821** error message?

**SYSTEM UNIT 100**

**XX:XX:XX**

**ERROR EXPANSION UNIT 182X**

**PRESS ENTER TO CONTINUE**

**?**

**YES** - Have the expansion unit and its cable serviced.

**NO** - Do the following:

1. Set the Power switches on the system unit and expansion unit to Off.
2. Set the Power switches on all attached devices to Off.
3. Disconnect the expansion-unit cable from the system unit.
4. Set the Power switch on the system unit to On.
5. Go to the next step.

4

When the POST finished, did the following appear on your screen?

1801

XX KB OK

ERROR. (RESUME = "F1" KEY)

YES - Press  and go to the next step.

NO - Go to the next step.

5

Press , then  to select

**RUN DIAGNOSTIC ROUTINES.**

The IBM Personal Computer **DIAGNOSTICS**  
Version XXX (C) Copyright IBM Corp XXXX

**SELECT AN OPTION**

**0 - RUN DIAGNOSTIC ROUTINES**

**1 - FORMAT DISKETTE**

**2 - COPY DISKETTE**

**3 - PREPARE SYSTEM FOR RELOCATION**

**9 - EXIT TO SYSTEM DISKETTE**

**ENTER THE ACTION DESIRED**

? -  -

**Note:** Depending on the configuration of your system, questions about attached devices may appear on your screen.

Press  or  as required,

then press





- 6 Are any of the options or devices installed in your expansion unit missing from the list?

THE INSTALLED DEVICES ARE

S SYSTEM BOARD  
S 256KB MEMORY  
S KEYBOARD  
S COLOR/GRAPHICS MONITOR ADAPTER  
S 2 DISKETTE DRIVE(S) AND ADAPTER  
E PRINTER ADAPTER  
S ASYNCHRONOUS COMMUNICATIONS ADAPTER  
S MATRIX PRINTER  
IS THE LIST CORRECT (Y/N)?

**Note:** The IBM Communications Cable and the Printer Cable will not appear in the list, and the Graphics Printer will be listed as "Matrix Printer." The Game Control Adapter may not be listed if the joysticks or paddles are not connected when the Power switch is set to On.

YES - Press  then  and go to the next step.

NO - Have the system unit serviced.

7 Press  to select

**RUN TESTS ONE TIME**, then .

**SYSTEM CHECKOUT**

- 0 - RUN TESTS ONE TIME
- 1 - RUN TESTS MULTIPLE TIMES
- 2 - LOG UTILITIES
- 9 - EXIT DIAGNOSTIC ROUTINES

**ENTER THE ACTION DESIRED**

?

Did you get an **1820** error message?

**YES** - Have the expansion unit and its cable serviced.

**NO** - Have the system unit serviced.





# Test 300

- 1 After approximately 2 minutes, did the following appear on your screen?



PRESS EACH KEY, HOLD FOR TYPOMATIC TEST  
IF OK PRESS "Y ENTER"  
IF NOT OK PRESS "N ENTER"

**YES** - Press each key once, then go to the next step.

**NO** - Press  then . Record the error message. Have the system unit serviced.

2



Did all the blocks change to characters as shown below?



1	2	←	1	2	3	4	5	6	7	8	9	Ø	-	=	↔	N	S		
3	4	⌞	Q	W	E	R	T	Y	U	I	O	P	[	]		7	8	9	-
5	6	C	A	S	D	F	G	H	J	K	L	;	'	`	R	4	5	6	
7	8	S	\	Z	X	C	V	B	N	M	,	.	/	S	*	1	2	3	+
9	0	A						S					C	Ø	.				

**PRESS EACH KEY HOLD FOR TYPEMATIC TEST**  
**IF OK PRESS "Y ENTER"**  
**IF NOT OK PRESS "N ENTER"**

**YES -** Press and hold any key. The corresponding character on the screen will blink. This is the typematic test.

If the typematic test works correctly,

press  then  and go to the next test. If the typematic test fails,

press  then . Record the error message. Have the keyboard serviced.

**NO -** Have the keyboard serviced.

# Test 400

**1** Do you have an IBM Monochrome Display and Printer Adapter installed in your system?

**NO** - Continue with the next Test.

**YES** - Did the following appear on your screen?

```
XX:XX:XX  
ERROR SYSTEM UNIT 4XX
```

**NO** - Continue with the next step.

**YES** - Record the error message and have the unit that contains the adapter serviced.

2

Do you have an IBM Monochrome Display attached to the IBM Monochrome Display and Printer Adapter installed in your system?

NO - Continue with the next Test.

YES - Did the following appear on your screen?

**DISPLAY ATTRIBUTES**

THIS LINE IS AT NORMAL INTENSITY.



THIS LINE IS INTENSIFIED.



THIS LINE IS IN REVERSE VIDEO.

THIS LINE IS BLINKING

THIS LINE IS UNDERLINED

IS THE SCREEN CORRECT? (Y/N)

YES - Press  then  and go to the next step.

NO - Press  then . Record the error message and have the unit that contains the adapter serviced.





**80X25 DISPLAY**



```

! " # $ % & ' ( ) * + , - . / 0 1 2 3 4 5 6 7 8 9 : ; < = > ? @ A B C D E F G H I J K L M N
! " # $ % & ' ( ) * + , - . / 0 1 2 3 4 5 6 7 8 9 : ; < = > ? @ A B C D E F G H I J K L M N O
" # $ % & ' ( ) * + , - . / 0 1 2 3 4 5 6 7 8 9 : ; < = > ? @ A B C D E F G H I J K L M N O P
# $ % & ' ( ) * + , - . / 0 1 2 3 4 5 6 7 8 9 : ; < = > ? @ A B C D E F G H I J K L M N O P Q
$ % & ' ( ) * + , - . / 0 1 2 3 4 5 6 7 8 9 : ; < = > ? @ A B C D E F G H I J K L M N O P Q R
% & ' ( ) * + , - . / 0 1 2 3 4 5 6 7 8 9 : ; < = > ? @ A B C D E F G H I J K L M N O P Q R S
& ' ( ) * + , - . / 0 1 2 3 4 5 6 7 8 9 : ; < = > ? @ A B C D E F G H I J K L M N O P Q R S T
' ( ) * + , - . / 0 1 2 3 4 5 6 7 8 9 : ; < = > ? @ A B C D E F G H I J K L M N O P Q R S T L
( ) * + , - . / 0 1 2 3 4 5 6 7 8 9 : ; < = > ? @ A B C D E F G H I J K L M N O P Q R S T U
) * + , - . / 0 1 2 3 4 5 6 7 8 9 : ; < = > ? @ A B C D E F G H I J K L M N O P Q R S T U V
* + , - . / 0 1 2 3 4 5 6 7 8 9 : ; < = > ? @ A B C D E F G H I J K L M N O P Q R S T U V W
+ , - . / 0 1 2 3 4 5 6 7 8 9 : ; < = > ? @ A B C D E F G H I J K L M N O P Q R S T U V W X Y
, - . / 0 1 2 3 4 5 6 7 8 9 : ; < = > ? @ A B C D E F G H I J K L M N O P Q R S T U V W X Y Z
- . / 0 1 2 3 4 5 6 7 8 9 : ; < = > ? @ A B C D E F G H I J K L M N O P Q R S T U V W X Y Z [
. / 0 1 2 3 4 5 6 7 8 9 : ; < = > ? @ A B C D E F G H I J K L M N O P Q R S T U V W X Y Z [ \
/ 0 1 2 3 4 5 6 7 8 9 : ; < = > ? @ A B C D E F G H I J K L M N O P Q R S T U V W X Y Z [ \ :

```

**IS THE SCREEN CORRECT? (Y/N)**

**YES** - Press  then . Your system has completed this test successfully. Continue with the next Test.

**NO** - Press  then . Record the error message and have the unit that contains the adapter serviced.

# Test 500

**1** Do you have a color display or TV attached to your system?

**NO** - Continue with the next Test.

**YES** - Did the following appear on your screen?

## DISPLAY ATTRIBUTES

THIS LINE IS AT NORMAL INTENSITY.



THIS LINE IS INTENSIFIED.



THIS LINE IS IN REVERSE VIDEO.

THIS LINE IS BLINKING.

	BLUE
	GREEN
	CYAN
	RED
	MAGENTA
	YELLOW
	WHITE

IS THE SCREEN CORRECT ? (Y/N)

**YES** - Press  then  and go to the next step.

**NO** - Press  then  . Record the error message and have the unit that contains the adapter serviced.







## 40X25 DISPLAY



```

! "$%&'()*+,-./0123456789:;<=>?@ABCDEF
! "$%&'()*+,-./0123456789:;<=>?@ABCDEFGH
! "$%&'()*+,-./0123456789:;<=>?@ABCDEFGHI
! "$%&'()*+,-./0123456789:;<=>?@ABCDEFGHIJ
! "$%&'()*+,-./0123456789:;<=>?@ABCDEFGHIJK
! "$%&'()*+,-./0123456789:;<=>?@ABCDEFGHIJKL
! "$%&'()*+,-./0123456789:;<=>?@ABCDEFGHIJKLM
! "$%&'()*+,-./0123456789:;<=>?@ABCDEFGHIJKLMN
! "$%&'()*+,-./0123456789:;<=>?@ABCDEFGHIJKLMNO
! "$%&'()*+,-./0123456789:;<=>?@ABCDEFGHIJKLMNOP
! "$%&'()*+,-./0123456789:;<=>?@ABCDEFGHIJKLMNOPQ
! "$%&'()*+,-./0123456789:;<=>?@ABCDEFGHIJKLMNOPQR
! "$%&'()*+,-./0123456789:;<=>?@ABCDEFGHIJKLMNOPQRS

```

IS THE SCREEN CORRECT? (Y/N)

YES - Press  then  and go to the next step.

NO - Press  then . Record the error message and have the unit that contains the adapter serviced.



5

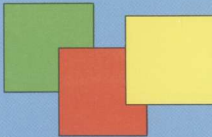

Did the following appear on your screen, with the correct colors?

320X200 GRAPHICS  
COLOR SET 0





IS THE SCREEN CORRECT? (Y/N)

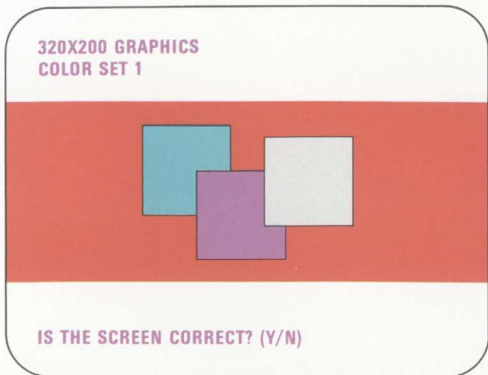

YES - Press  then  and go to the next step.

NO - Press  then . Record the error message and have the unit that contains the adapter serviced.

- 6 Did the following appear on your screen, with the correct colors?





**YES** - Press  then  and go to the next step.

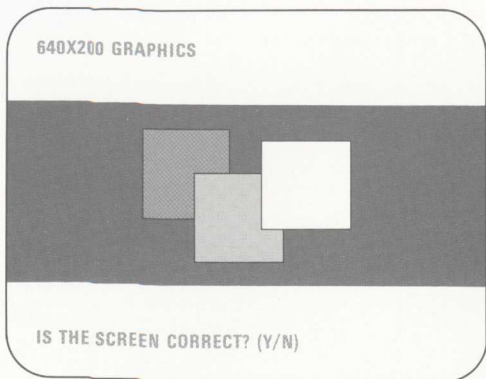

**NO** - Press  then  . Record the error message and have the unit that contains the adapter serviced.

**7**

Did the following appear on your screen?



**YES** - Press  then  and go to the next step.

**NO** - Press  then  . Record the error message and have the unit that contains the adapter serviced.







# Test 600

- 1 Remove the Diagnostics diskette.
- 2 Does your screen match the one shown in the figure below?

```
SYSTEM UNIT      XXX
**** WARNING ****
DATA WILL BE DESTROYED
INSERT SCRATCH DISKETTE IN DRIVE A:
PRESS ENTER WHEN READY
? -  -
```



**YES** - Go to the next step.

**NO** - Record the error message and have the system unit serviced.

- 3 Insert a scratch diskette into drive A,  
and press .

- 4 Did the following appear on your screen and is the drive type correct?

**DISKETTE DRIVE A: IS DOUBLE SIDED  
IS THE DISKETTE DRIVE TYPE  
CORRECT - (Y/N)?**

**YES -** Press  then . If you have two diskette drives installed in your system, go to the next step. If you have only one diskette drive, your system has completed this test successfully. Continue with the next Test.

**NO -** Have the system unit serviced.

5

Did the following appear on your screen?



\*\*\* WARNING \*\*\*  
DATA WILL BE DESTROYED  
INSERT SCRATCH DISKETTE IN DRIVE B:  
PRESS ENTER WHEN READY  
? -  -

**YES** - Remove the scratch diskette from drive  
A, place it in drive B, and press  .  
Go to the next step.

**NO** - Have the system unit serviced.

- 6** Did the following appear on your screen and is the drive type correct?

**DISKETTE DRIVE B: IS DOUBLE SIDED  
IS THE DISKETTE DRIVE TYPE  
CORRECT - (Y/N)?**

**YES** - Press  then  . Your system has completed this test successfully. Continue with the next Test.

**NO** - Have the system unit serviced.

# Test 700

**1** Do you have an IBM Math Coprocessor installed in your system?

**NO** - Continue with the next Test.

**YES** - Did the following appear and remain on your screen for more than 10 seconds?



SYSTEM UNIT                      600

**YES** - Have the system unit serviced.

**NO** - Go to the next step.

2

Did the following appear on your screen?

XX:XX:XX

ERROR - SYSTEM UNIT

7XX

**YES** - Have the System unit serviced.

**NO** - Your system has completed this test successfully. Continue with the next Test.

# Test 900

Do you have an IBM Printer Adapter installed in your system?

**NO** - Continue with the next Test.

**YES** - Did either of the following error messages appear on your screen?

```
XX:XX:XX  
ERROR - SYSTEM UNIT      9XX
```

```
XX:XX:XX  
ERROR EXPANSION UNIT     9XX
```

**YES** - Have the unit that contains the adapter serviced.

**NO** - Your system has completed this test successfully. Continue with the next Test.



# Test 1100

Do you have an IBM Asynchronous Communications Adapter installed in your system?

**NO** - Continue with the next Test.

**YES** - Did any of the following error messages appear on your screen?

XX:XX:XX ERROR - SYSTEM UNIT	11XX
XX:XX:XX ERROR - SYSTEM UNIT	12XX
XX:XX:XX ERROR EXPANSION UNIT	11XX
XX:XX:XX ERROR EXPANSION UNIT	12XX

**YES** - Have the unit that contains the adapter serviced.

**NO** - Your system has completed this test successfully. Continue with the next Test.



# Test 1300

**1** Do you have an IBM Game Control Adapter installed in your system?



**NO** - Continue with the next Test.

**YES** - Did the following appear on your screen?

**DO YOU HAVE JOYSTICKS, PADDLES,  
OR NOTHING ATTACHED (J P N)?**

**YES** - For joysticks press  then  and go to Step 2.

For paddles press  then  and go to Step 5.

For nothing press  then   
and continue with the next Test.

**NO** - Continue with the next Test.

2 Press  then  .

3 Check for correct operation of your joysticks as follows:

1. Press each button and watch the word **RELEASED** change to **PRESSED**
2. Move each joystick and watch the character **A** or **B** move inside the box.

HOW MANY BUTTONS DO YOU HAVE (2/4)? 2

BUTTON A

BUTTON B

RELEASED

RELEASED

\*\*\*\*\*

\*\*\*\*\*

\* \* \*

\* \* \*

\* \* \*

\* \* \*

\* A \*

\* B \*

\* \* \*

\* \* \*

\* \* \*

\* \* \*

\*\*\*\*\*



\*\*\*\*\*

PRESS AND RELEASE ALL BUTTONS,  
EXERCISE ALL JOYSTICKS/PADDLES  
AND PRESS ANY KEY WHEN DONE

**4** Did all buttons and joysticks operate correctly?

**YES** - Your system has completed this test successfully. Press any key and continue with the next Test.

**NO** - Have the joysticks and the unit in which the Game Control Adapter is installed serviced.

5 Press  or  for the number of paddles attached to your Game Control Adapter and press .

6 Press the same number for the number of buttons and press .

7 Check for correct operation of your paddles as follows:

1. Press each button and watch the word **RELEASED** change to **PRESSED**.
2. Turn each paddle control and check that **A**, **B**, **C**, or **D** moves inside the box.

HOW MANY BUTTONS DO YOU HAVE (2/4)?

BUTTON A	BUTTON B	BUTTON C	BUTTON D
RELEASED	RELEASED	RELEASED	RELEASED

\*\*\*\*\*

\* A \*

\*\*\*\*\*

\*\*\*\*\*

\* C \*

\*\*\*\*\*

\*\*\*\*\*

\* B \*

\*\*\*\*\*

\*\*\*\*\*

\* D \*

\*\*\*\*\*

**PRESS AND RELEASE ALL BUTTONS,  
EXERCISE ALL JOYSTICKS/PADDLES  
AND PRESS ANY KEY WHEN DONE**

Go to the next step.

**8**

Did all buttons and paddle controls operate correctly?

**YES** - Your system has completed this test successfully. Press any key and continue with the next Test.

**NO** - Have the paddles and the unit in which the Game Control Adapter is installed serviced.



# Test 1500

Do you have an IBM Synchronous Data Link Control Adapter installed in your system?

**NO** - Continue with the next Test.

**YES** - Did either of the following error messages appear on your screen?

```
XX:XX:XX  
ERROR - SYSTEM UNIT      15XX
```

```
XX:XX:XX  
ERROR EXPANSION UNIT     15XX
```

**YES** - Have the unit that contains the adapter serviced.

**NO** - Your system has completed this test successfully. Continue with the next Test.







# Test 1700

1 Do you have a fixed disk drive installed in one of your units?

NO - Continue with the next Test.

YES - The following appears on your screen.

\*\*\* WARNING \*\*\*  
DATA ON CYLINDER 305 WILL BE  
OVERWRITTEN BY FIXED DISK WRITE TESTS  
DO YOU WANT TO INCLUDE FIXED DISK  
WRITE TESTS ON DRIVE C: (Y/N) ?

Press  and then  if you want to include fixed-disk write tests, or  and then  if you do not.

Go to the next step.

This test can take up to 5 minutes.

**2** Did the following appear on your screen?

**Note:** If you pressed N (no write test), **PERFORMING WRITE TEST** will not appear.

**\*\*\* WARNING \*\*\***  
**DATA ON CYLINDER 305 WILL BE**  
**OVERWRITTEN BY FIXED DISK WRITE TESTS**

**DO YOU WANT TO INCLUDE FIXED DISK**  
**WRITE TESTS ON DRIVE C: (Y/N) ? y**  
**PERFORMING SEEK TEST**  
**PERFORMING WRITE TEST**  
**PERFORMING TRACK ZERO TEST**  
**PERFORMING SURFACE SCAN**  
**PLEASE STAND BY**





- YES** - If you have one fixed disk drive, your system has successfully completed this test. Continue with the next Test. If you have two fixed disk drives, continue.
- NO** - Record the error message and have the unit that contains the fixed disk drive serviced.

3

Did the following appear on your screen?

**\*\*\* WARNING \*\*\***  
**DATA ON CYLINDER 305 WILL BE**  
**OVERWRITTEN BY FIXED DISK WRITE TESTS**

**DO YOU WANT TO INCLUDE FIXED DISK**  
**WRITE TESTS ON DRIVE D: (Y/N) ?**

**YES** - Press  and then  if you  
want to include fixed-disk write tests, or  
 and then  if you do not.  
Go to the next step.

**NO** - Record the error message and have the  
expansion unit serviced.

4

Did the following appear on your screen?

**Note:** If you pressed N (no write test), **PERFORMING WRITE TEST** will not appear.

DO YOU WANT TO INCLUDE FIXED DISK  
WRITE TESTS ON DRIVE D: (Y/N) ? y  
PERFORMING SEEK TEST  
PERFORMING WRITE TEST  
PERFORMING TRACK ZERO TEST  
PERFORMING SURFACE SCAN  
PLEASE STAND BY

**YES** - Your system has successfully completed this test. Continue with the next Test.

**NO** - Record the error message and have the expansion unit serviced.

# Test 2000

Do you have an IBM Binary Synchronous Communications Adapter installed in your system?

**NO** - Continue with the next Test.

**YES** - Did any of the following error messages appear on your screen?

```
XX:XX:XX  
ERROR - SYSTEM UNIT      20XX
```

```
XX:XX:XX  
ERROR - SYSTEM UNIT      21XX
```

```
XX:XX:XX  
ERROR EXPANSION UNIT     20XX
```

```
XX:XX:XX  
ERROR EXPANSION UNIT     21XX
```

**YES** - Have the unit that contains the adapter serviced.

**NO** - Your system has completed this test successfully. Continue with the next Test.



# Test 2200

**1** Do you have an IBM Personal Computer Cluster Adapter installed in your system?

**NO** - Continue with the next Test.

**YES** - Did either of the following error messages appear on your screen?

```
XX:XX:XX  
ERROR-SYSTEM UNIT          22XX X
```

```
XX:XX:XX  
ERROR-EXPANSION UNIT       22XX X
```

**YES** - Have the unit that contains the adapter and the terminating plug serviced.

**NO** - Go to the next step.

- 2** Did either of the following error messages appear on your screen?

```
TESTING - CLUSTER ADAPTER X  
THE STATION ADDRESS IS XX  
REMOTE IPL IS NOT SELECTED  
  XX:XX:XX  
ERROR - SYSTEM UNIT 22XX  
ERROR - EXPANSION UNIT 22XX  
PRESS ENTER TO CONTINUE  
?
```

- YES** - Have the unit that contains the adapter and the terminating plug serviced.
- NO** - Go to the next step.

**3** The following will appear on your screen.

**Note:** When more than one Cluster Adapter is installed in a Personal Computer, each of the adapters will be tested.

**TESTING – CLUSTER ADAPTER X  
THE STATION ADDRESS IS XX  
REMOTE IPL IS NOT SELECTED  
DO YOU WANT TO DISPLAY THE  
CLUSTER STATUS (Y/N) ?**

Go to the next step.

**4**

Does the adapter number, station address, and remote IPL information shown on your screen match the switch setting information you entered below?

Cluster Adapter Number \_\_\_\_\_

Station Address \_\_\_\_\_

Remote IPL (Is/Is Not) Selected \_\_\_\_\_

**YES** - Go to the next step.

**NO** - If the adapter number, station address, or remote IPL information is not correct, have the unit that contains the adapter serviced.



Do you want to display the cluster status?

**Note:** The cluster-status screen presentation will show 64 boxes that represent the stations in the cluster that have their Power switch set to On and are connected to the cluster bus.



**TESTING – CLUSTER ADAPTER X  
THE STATION ADDRESS IS XX  
REMOTE IPL IS NOT SELECTED**

**DO YOU WANT TO DISPLAY THE  
CLUSTER STATUS (Y/N)?**

**YES -** Set the Power switch on all cluster system units (and expansion units, if installed) to On,

press  then , then go to the next step.

**NO -** Your system has successfully completed this test. Remove the terminating plug and attach the coaxial cable to the Cluster Adapter connector.

Press , then  and continue with the next Test.

**6** The following will appear on your screen.

TESTING - CLUSTER ADAPTER X  
THE STATION ADDRESS IS X  
REMOTE IPL IS NOT SELECTED

DO YOU WANT TO DISPLAY THE  
CLUSTER STATUS (Y/N) ? y

CONNECT THE CABLE TO THE  
CLUSTER ADAPTER

PRESS ENTER WHEN READY  
?

Disconnect the terminating plug and attach the  
coaxial cable to the Cluster Adapter's connector.

Press  and go to the next page.

This page explains the cluster status that may appear on your screen.

NN is any station address from 0 to 63.

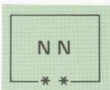

The system you are using is indicated on the screen in blinking reverse video, and the box is marked by two asterisks.

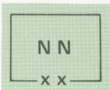

Stations that have their Power switch set to On are displayed in reverse video, and their boxes are marked by two Xs.

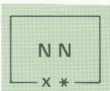

If another Personal Computer has the same station address as your Personal Computer, a long beep will sound every 3 seconds, the box will be displayed in blinking reverse video and will be marked by an X and an asterisk.



A station address not in the cluster is indicated by a box displayed in normal video and not marked with Xs or asterisks.

A Cluster-Access Error message may be displayed in reverse video.

Go to next step.

7

Wait 15 seconds. Do all stations in the cluster appear and remain on the screen presentation?

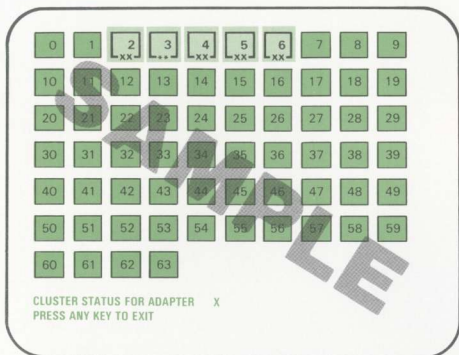

### Notes:

1. Your installation manager has a cluster map that lists the station addresses and the order in which the stations are connected. Compare the map and the status screen presentation to determine that all stations in the cluster are operating properly.
2. The status screen shows all stations installed on your cluster, and is updated every 3 seconds to show stations that are added to or removed from the cluster.

**YES** - Your system has successfully completed this test. Press any key and continue with the next Test.

**NO** - Go to the next step.

8

Did a box appear in blinking reverse video with an X and asterisk, and did a beep sound every 3 seconds?

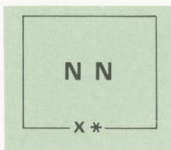

**YES** - Another Personal Computer has the same station address as your Personal Computer. Compare your cluster map with the status screen presentation. Do the system diagnostic tests on the Personal Computer missing from the cluster-status screen presentation.

Have the unit that contains the failing adapter serviced.

**NO** - Go to the next step.

9

Did a box appear in normal video with no Xs or asterisks, for a station address that is in the cluster?

**Note:** Multiple grounds on cluster cables may cause stations to appear on the status screen presentation intermittently. If this happens, notify your installation manager.



**YES -** Go to Step 11.

**NO -** Go to the next step.

# 10 Do you have a cluster-access error?

0	1	2	3	4	5	6	7	8	9
10	11	12	13	14	15	16	17	18	19
20	21	22	23	24	25	26	27	28	29
30	31	32	33	34	35	36	37	38	39
40	41	42	43	44	45	46	47	48	49
50	51	52	53	54	55	56	57	58	59
60	61	62	63						

CLUSTER ACCESS ERROR  
PRESS ENTER TO CONTINUE

**YES** - Go to Step 11.

**NO** - Your system has successfully completed this test. Continue with the next Test.

**11** You have stations that are not indicated on any status screen presentation, or by a cluster-access error message.

1. Do the system diagnostic tests on a station that is not indicated on any status screen presentation, or that has a cluster-access error.
2. If the diagnostic test fails, have the unit that contains the adapter serviced.
3. If the diagnostic test passes, continue doing the diagnostic tests until you test all of the stations that did not appear on any status screen presentation or that had a cluster-access error.
4. If the Cluster Adapters check good and the stations did not appear on the cluster-status screen presentations, notify your installation manager that you suspect the coaxial cable or a terminating plug.

**Note:** If you have more than one Cluster Adapter installed in your system, go back to page 2200-1 and continue until all Cluster Adapters are tested.

# Test 7000

Do you have an IBM Printer attached to your system?

**YES** - Continue with the next Test.

**NO** - You have completed the Problem Determination Procedures with no failures. Remove the scratch diskette from your drive. Return the Diagnostics diskette to the back of this manual. Your system unit is ready to load your operating system.

If you should have any other problems, contact your place of purchase for additional help.







**2** Did the printer test finish without any errors and the printer test pattern print correctly?

**NO** - Record the error message, and go to Test 8000.

**YES** - Continue with the next Test.



# Test 7020

**1** Do you have an IBM PC Compact Printer attached to your system?

**NO** - Continue with the next Test.

**YES** - The following printer test pattern should print.

## Compact Printer Example

```
!"#$%&'()*+,-./
0 1 2 3 4 5 6 7 8 9 : ; < = > ?
@ABCDEFGHIJKLMNO
PQRSTUVWXYZ[\]^_
!"#$%&'()*+,-./
0 1 2 3 4 5 6 7 8 9 : ; < = > ?
ABCDEFGHIJKLMNO

```

**2** Did the printer test finish without any errors and the printer test pattern print correctly?

**NO** - Go to Test 8010.

**YES** - Continue with the next Test.



# Test 7030

**1** Do you have an IBM Personal Computer Color Printer attached to your system?

**NO** - Continue with the next Test.

**YES** - Does your screen match the screen shown below?

**SELECT PAPER WIDTH**

**1 - 8 1/2 INCH PAPER WIDTH**

**2 - 14 1/2 INCH PAPER WIDTH**

**ENTER THE OPTION DESIRED**

**?**

**NO** - Go to Test 8020.

**YES** - Go to the next step.

2

Select the width of paper you are using.



**SELECT PAPER WIDTH**



1 - 8 1/2 INCH PAPER WIDTH

2 - 14 1/2 INCH PAPER WIDTH

**ENTER THE OPTION DESIRED**

?

Press  then  for paper  
8-1/2 inches wide.

Press  then  for paper  
14-1/2 inches wide.



**Note:** If the print example shows the incorrect character set, check the DIP switches. If the DIP switches are set correctly, have your printer serviced.

**4** Did the printer test pattern finish without any errors and the printer test pattern print correctly?



**YES -** Go to the next step.



**NO -** If the test pattern is correct but the colors are wrong, go to the next step. If the test pattern is not correct or you received an error message, record the error message and go to Test 8020.

5

Are the characters in your test pattern correct and is each character only one color?

ARE THE CHARACTERS ON THE PRINTED  
TEST PATTERN CORRECT, AND EACH  
CHARACTER A SINGLE COLOR (Y/N)  
?

YES - Press  then  and  
go to Step 8.

NO - Press  then  and  
continue on the next step.

**Note:** Refer to the "Ribbon-Color Knob Adjustment" procedure in the "IBM Personal Computer Color Printer Installation and Operating Instructions" in your *Guide to Operations*.

- 6** Perform the ribbon adjustment procedure. Then press  to print the test pattern and verify the adjustment.

**Warning:** Wait until the printer stops before making any adjustments.

- 7** Return to Step 4.

**Note:** If you are unable to adjust the ribbon, have the printer serviced.

- 8** Continue with the next Test.

# Test 7900

You have completed the problem determination procedures. Remove the scratch diskette from your drive. Return the Diagnostics diskette to the back of this manual. Your system unit is now ready for you to load your operating system.

If you encounter any other problems, contact your place of purchase for additional help.



# Test 8000

- 1 Check your wall outlet for proper operation (use a working lamp).
- 2 Verify that the Printer Cable is properly connected to the printer and the system unit.

Did you find any problem while doing the above step?

**NO** - Go to the next step.

**YES** - Correct the problem and perform the system diagnostic tests again.

- 3 Set the Power switches on the printer and system unit to Off. (If an expansion unit is attached, also set its Power switch to Off.)
- 4 Disconnect the Printer Cable.

## 5

Perform the printer self-test:

1. Press and hold the Line Feed button while you set the printer's Power switch to On.
2. When the test starts, release the Line Feed button.

**Note:** The printer self-test takes approximately 10 minutes.

3. To stop the test before it finishes, set the printer's Power switch to Off.



Sample Printout for International Graphics  
Printer

...?@A  
...; <=>?@AB  
...() \*+, -./0123456789: ; <=>?@ABC  
##%&? () \*+, -./0123456789: ; <=>?@ABCD  
!"##%&? () \*+, -./0123456789: ; <=>?@ABCDE  
!"##%&? () \*+, -./0123456789: ; <=>?@ABCDEF  
!"##%&? () \*+, -./0123456789: ; <=>?@ABCDEFG  
!"##%&? () \*+, -./0123456789: ; <=>?@ABCDEFGH  
##%&? () \*+, -./0123456789: ; <=>?@ABCDEFGHI  
%&? () \*+, -./0123456789: ; <=>?@ABCDEFGHI  
%&? () \*+, -./0123456789: ; <=>?@ABCDEFGH  
%&? () \*+, -./0123456789: ; <=>?@ABC  
() \*+, -./0123456789: ; <=>?@ABC  
() \*+, -./0123456789: ; <=>?@ABC

Did the self-test finish without failures?

YES - Go to Step 13.

NO - Go to the next step.

- 7 Ensure the ribbon is installed properly.
- 8 Ensure the forms or paper is inserted properly.
- 9 Ensure the forms or paper path has no obstructions.
- 10 Ensure the tractors are adjusted properly.

If you need help with any of the above, refer to the operating instructions that came with your printer.

- 11 Did you find any problem while doing the above steps?

**NO** - Go to the next step.

**YES** - Correct the problem and restart the printer self-test.

**Note:** If you are using a non-U.S. English keyboard and your printout does not match the desired character set, have your printer serviced.

**12** Does your printer have any of the following problems?

- It beeps even though the paper is inserted properly.
- It does not beep even when out of paper.
- Some lights on the control panel do not work.
- Some buttons on the control panel do not work.
- The printer continues to print when out of paper.
- The printer fails to print or prints incorrectly.

**NO** - Go to Step 14.

**YES** - Have your printer serviced.

**13** Did you receive any of the following error messages during diagnostic testing?

199

432

901

1401

**YES** - Go to the next step.

**NO** - If you are still having a problem, go to step 16.

**14** Leave the Printer Cable disconnected from the printer and do the system diagnostic tests again. Verify that the list of installed devices and options is correct (your printer will be missing from the list).

**15** Did you receive the same error message during the system diagnostic tests?

**YES** - If your printer is attached to an adapter in your system unit, have the system unit serviced. If your printer is attached to an adapter in the expansion unit, have the expansion unit serviced.

**NO** - Have the printer and cable serviced.

**16** Your printer also is controlled by program commands from the system unit. If you still have a printer problem, or if the problem occurs only during a particular program, examine the program thoroughly for commands that might cause the printer to produce undesired results.

If you complete the printer self-test and have no apparent program problems, have the unit to which the printer is attached serviced.

# Test 8010

- 1** Check your wall outlet for proper operation (use a working lamp).
- 2** Verify that the Printer Cable is properly connected to the printer and system unit.

Did you find any problem while doing the above step?

**NO** - Go to the next step.

**YES** - Correct the problem and perform the system diagnostic tests again.

- 3** Set the Power switches on the printer and system unit to Off. (If an expansion unit is attached, also set its Power switch to Off.)
- 4** Disconnect the Printer Cable.

**5** Perform the printer self-test:

1. Be sure that nothing prevents the paper from moving.
2. Be sure the top cover is closed properly.
3. Press and hold down the Form Feed button while you set the printer's Power switch to On.
4. When the test starts, release the Form Feed button.

**6** This test will run until you set the printer's Power switch is set to Off.



**8** Does your printer have any of the following problems?

- Its Ready light blinks continuously.
- It prints reversed question marks continuously.
- It prints characters with extra or missing dots.
- It sounds as if it is operating but does not print. (Be sure the paper is inserted properly.)
- It does not do anything.

**YES** - Have your IBM PC Compact Printer serviced.

**NO** - Go to the next step.

**9** Your printer also is controlled by program commands from the system unit. If you still have a printer problem, or a problem occurs only during a particular program, examine the program thoroughly for commands that might cause the printer to produce undesired results.

**10** If you have completed the printer self-test and have no apparent program problems, have the unit to which the printer is attached serviced.

# Test 8020

**1** Check your wall outlet for proper operation (use a working lamp).

**2** Verify that the Printer Cable is properly connected to the printer and system unit.

Did you find any problem while doing the above step?

**NO** - Go to the next step.

**YES** - Correct the problem and perform the system diagnostic tests again.

**3** Set the Power switches on the printer and system unit to Off. (If an expansion unit is attached, also set its Power switch to Off.)

**4** Disconnect the Printer Cable.

# 5

Perform the printer self-test:

1. Open the access cover and set all DIP switches to Off.
2. Close the access cover.
3. Set the printer's Power switch to On.
4. Press the Ready button to set the printer to the Not Ready state (Ready light is off).
5. Press the Test Mode button.
6. To stop the test, press the Test Mode button again.

6

Below is a sample of the printout for the IBM Personal Computer Color Printer. Compare your printout with the sample.



Did the self-test finish without failures?

YES - Go to Step 15.

NO - Go to the next step.

- 7 Ensure the ribbon is installed properly.
- 8 Ensure your forms or paper is inserted properly.
- 9 Ensure the forms path or paper path has no obstructions.
- 10 Ensure the tractors are adjusted properly.

If you need help with any of the above, refer to the operating instructions that came with your printer.

Did you find any problem while doing the above steps?

**NO** - Go to the next step.

**YES** - Correct the problem and restart the printer self-test.

**Note:** If you are using a non-U.S. English keyboard and your printout does not match the desired character set, verify that the switch settings are correct for the desired character set. If the switch settings are correct, have your printer serviced.

**11** Does your printer have any of the following problems?

- It beeps even though the paper is inserted properly.
- It does not beep even when out of paper.
- Some lights on the control panel do not work.
- Some buttons on the control panel do not work.
- The printer continues to print when out of paper.
- The printer fails to print or prints incorrectly.

**NO** - Go to Step 18.

**YES** - Go to the next step.

**12** Ensure that all DIP switches are set to Off. (See the switch setting charts in your printer's installation and operating instructions.)

**13** Ensure the Forms Thickness Control lever is properly adjusted.

**14** Ensure the Feed Mode lever is in the correct position.

Did you find any problem while doing the above steps?

**NO** - Have your printer serviced.

**YES** - Correct the problem and restart the printer self-test.

**15** If you receive any of the following error messages during diagnostic testing, continue with the next step:

199

432

901

1401

2901

2902

If you did not receive any of the error messages but still have a problem, go to Step 18.

**16** Leave the Printer Cable disconnected from the printer and do the system diagnostic tests again. Verify that the list of installed devices and options is correct (your printer will be missing from the list).

**17** Did you receive the same error message during the tests?

**YES** - If your printer was attached to an adapter in your system unit, have the system unit serviced. If your printer was attached to an adapter in the expansion unit, have the expansion unit serviced. Remember to reset the DIP switches.

**NO** - Have the printer and its cable serviced.

**18** Your printer also is controlled by program commands from the system unit. If you are still having a printer problem, or if a problem occurs only during a particular program, examine the program thoroughly for commands that might cause the printer to produce undesired results.

If you have completed the printer self-test and have no apparent program problems, have the unit to which the printer is attached serviced.

Remember to reset the DIP switches.



# Test 9000

**Note:** If your IBM Color Display requires service, it must be returned with the power cord.

- 1** Set the Power control to On.

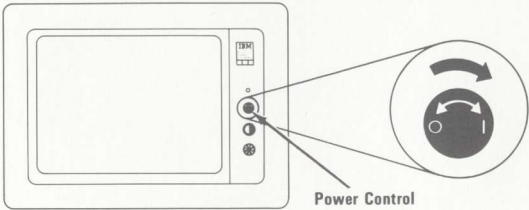

- 2** Is the Power-On indicator lit?

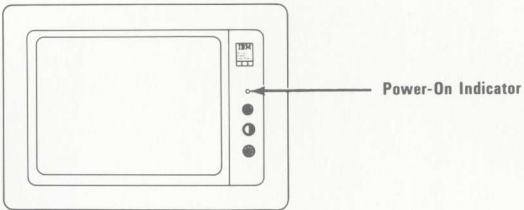

**YES** - Go to the next step.

**NO** - Check that the power cord is plugged into a functioning wall outlet and into the rear of the display. If it is, have the display serviced.

- 3 Set the Power switch on the system unit (and expansion unit, if attached) to Off.
- 4 Turn the Brightness and Contrast controls fully clockwise.

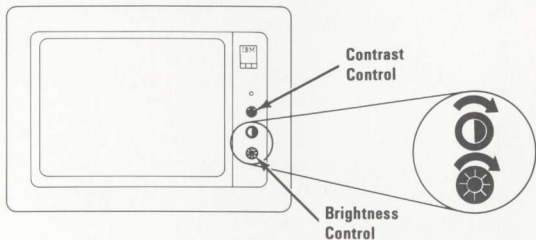

- 5 Turn the Vertical Size control fully counterclockwise. A black area should appear across the top and bottom of the screen.

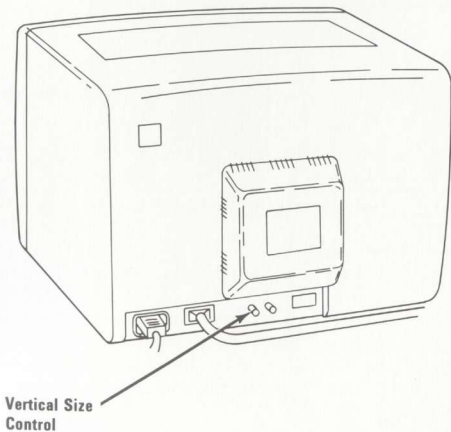

- 6 Does the black area appear across the top and bottom of the screen?

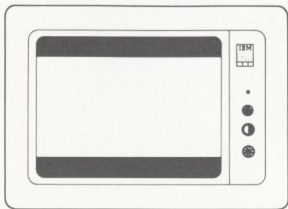

YES - Go to the next step.

NO - Have the display serviced.

- 7 Are the black areas approximately the same size?



YES - Go to the next step.

NO - Have the display serviced.

- 8** Turn the Vertical Size control clockwise until the black areas just disappear. If one of the black areas disappears before the other, continue to turn the control until the second black area is gone.

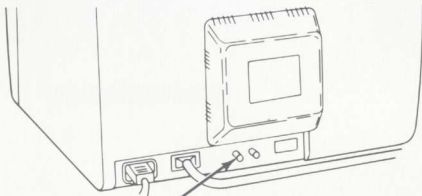

**Vertical Size  
Control**

- 9** Is the entire screen white?

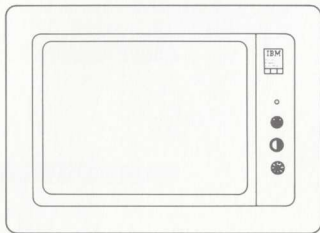

**YES** - Go to Step 14.

**NO** - Go to the next step.

- 10 Set the display's Power control to Off.
- 11 Disconnect the display's signal cable from the system unit (or expansion unit).

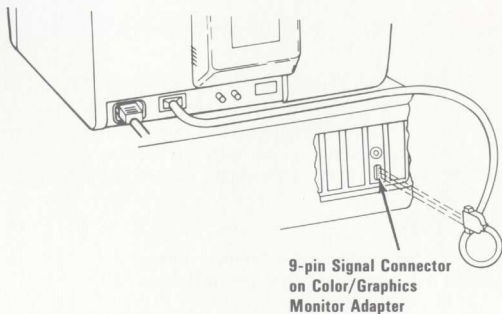

- 12 Set the display's Power control to On.
- 13 Is the screen white?
  - YES - Have the unit to which the display was attached serviced.
  - NO - Have the display serviced.
- 14 Watch the screen and set the Power switch on the expansion unit (if attached) to On. Then set the system unit's Power switch to On.

- 15** Did the screen change from white to black when the Power switch was set to On? (The screen may remain black for only 13 seconds before changing again.)

**YES** - Go to the next step.

**NO** - Have the display serviced.

- 16** Wait for the power-on self test (POST) to finish. The IBM Personal Computer BASIC message, with a blinking cursor, appears unless a diskette is inserted or an operating system is automatically loaded from a fixed disk drive.

The IBM Personal Computer Basic  
Version CX.XX Copyright IBM Corp. XXXX  
XXXXX Bytes free  
Ok

1LIST 2RUN 3LOAD" 4SAVE" 5CONT 6LPT1 7TRON 8TROFF 9KEY 0SCREEN

**17** Is your screen blank?

**NO** - Go to the next step.

**YES** - Have the unit to which the display was attached serviced.

**18** Is the screen presentation steady?

**YES** - Go to Step 21.

**NO** - Go to the next step.

**19** Turn the Vertical Hold control clockwise as far as it will go, then turn it counterclockwise until the presentation is steady.

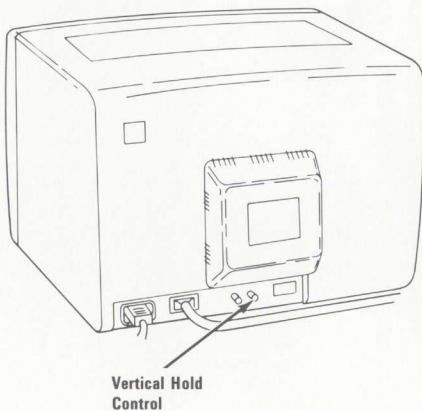

**20** Were you able to make the presentation steady?

**YES** - Go to the next step.

**NO** - Have the display serviced.

**21** Does the screen have white characters on a dark background?

**YES** - Go to Step 27.

**NO** - Go to the next step.

**17** Is your screen blank?

**NO** - Go to the next step.

**YES** - Have the unit to which the display was attached serviced.

**18** Is the screen presentation steady?

**YES** - Go to Step 21.

**NO** - Go to the next step.

**19** Turn the Vertical Hold control clockwise as far as it will go, then turn it counterclockwise until the presentation is steady.

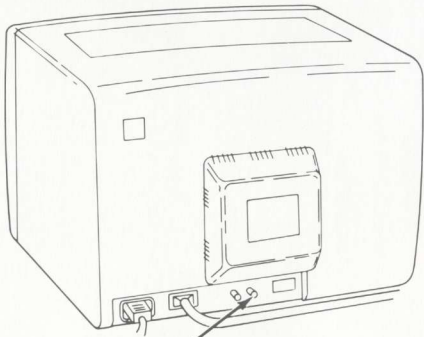

**Vertical Hold  
Control**

**20** Were you able to make the presentation steady?

**YES** - Go to the next step.

**NO** - Have the display serviced.

**21** Does the screen have white characters on a dark background?

**YES** - Go to Step 27.

**NO** - Go to the next step.

**22** Set the Power switch on the system unit (and expansion unit, if attached) to Off.

**23** Set the display's Power control to Off.

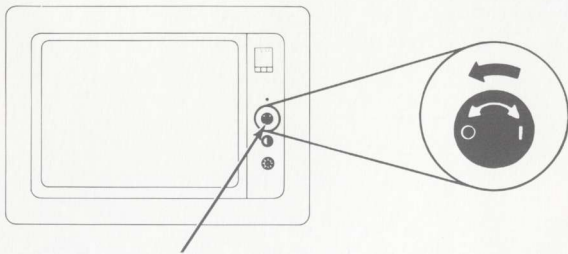

**Power Control**

**24** Disconnect the display's signal cable from the system unit (or expansion unit).

**25** Set the display's Power control to On.

**26** Is the screen white?

**YES** - Have the unit to which the display was attached serviced.

**NO** - Have the display serviced.

**27** Turn the Brightness control fully counterclockwise.

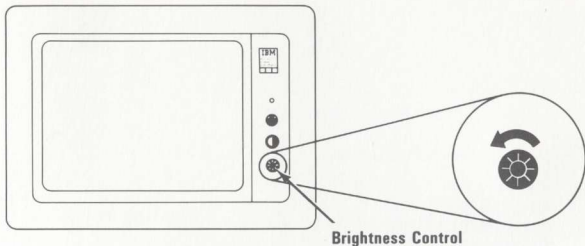

**28** Does the intensity of the characters decrease?

**YES** - Go to the next step.

**NO** - Have the display serviced.

- 29** Turn the Brightness control fully clockwise and the Contrast control fully counterclockwise.

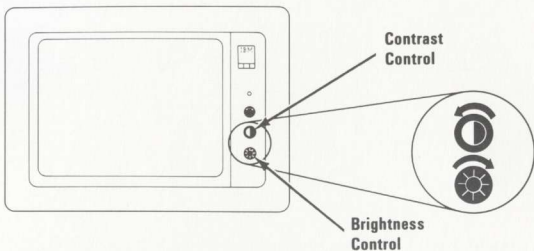

- 30** Does the intensity of the characters decrease?  
YES - Go to the next step.  
NO - Have the display serviced.

**31** Turn the Contrast control fully clockwise. Can you find your problem in the following examples?



**Too Dim**



**Too Wide**



**Too Narrow**



**Out of Focus**



**Shrunken**



**Characters shifted left or right or up and down off the display area**



**Tilted**

**YES** - Have your display serviced.

**NO** - Go to "Diagnostic Testing" on page Test 000-1 earlier in this section.

# Test 2400

1

Do you have an IBM Enhanced Graphics Adapter installed in your system?

**NO** - Continue with the next Test.



**YES** - Is the amount of graphics memory displayed the correct amount for your system?

**XXXXKB GRAPHICS MEMORY INSTALLED.**

**IS THIS CORRECT(Y/N)?**

**Note:** **XXXXKB** will be either 64KB, 128KB, or 256KB.

**YES** - Press  then  and go to Step 3.

**NO** - Press  then  and go to the next step.

**2** Did the following screen appear?

**XXXKB GRAPHICS MEMORY INSTALLED.**

**IS THIS CORRECT(Y/N)?**

**HOW MUCH MEMORY IS INSTALLED(KB)?**

**YES** - Type in the correct amount of graphics memory installed and press  and go to the next step.

**NO** - Go to the next step.

**3** Do you have an IBM Enhanced Color Display connected to your Enhanced Graphics Adapter?

**NO** - Go to Step 19.

**YES** - Did the following appear on your screen (ignore color problems)?

**DISPLAY ATTRIBUTES**

**THIS LINE IS AT NORMAL INTENSITY.**

**THIS LINE IS INTENSIFIED.**

**THIS LINE IS IN REVERSE VIDEO.**

**THIS LINE IS BLINKING.**



red



green



blue



grays

**IS THE SCREEN CORRECT? (Y/N)** 

**YES** - Go to the next step.

**NO** - Press  then  . Record the

error message and have the unit that contains the adapter serviced.

- 4** Examine the Display attributes screen. Are the colors correct?

**Note:** There should be three different shades of each color.

**DISPLAY ATTRIBUTES**

THIS LINE IS AT NORMAL INTENSITY.

THIS LINE IS INTENSIFIED.

THIS LINE IS IN REVERSE VIDEO.

THIS LINE IS BLINKING.



red



green





blue



grays

IS THE SCREEN CORRECT? (Y/N) 

**YES** - Press  then  and go to the next step.

**NO** - Have the display serviced.

- 5 Did the following appear on your screen (ignore color problems)?

DISPLAY ATTRIBUTES

THIS LINE IS AT NORMAL INTENSITY.

THIS LINE IS INTENSIFIED.

THIS LINE IS IN REVERSE VIDEO.

THIS LINE IS BLINKING.

	BLUE
	GREEN
	CYAN
	RED
	MAGENTA
	BROWN
	WHITE

IS THE SCREEN CORRECT ? (Y/N)

**YES** - Go to the next step.

**NO** - Press  then  . Record the

error message and have the unit that contains the adapter serviced.

- 6** Examine the Display attributes screen. Are the colors correct?

**Note:** There should be two different shades of each color.

DISPLAY ATTRIBUTES

THIS LINE IS AT NORMAL INTENSITY.



THIS LINE IS INTENSIFIED.

THIS LINE IS IN REVERSE VIDEO.

THIS LINE IS BLINKING.



IS THE SCREEN CORRECT ? (Y/N)

**YES** - Press  then  and go to the next step.

**NO** - Have the display serviced.









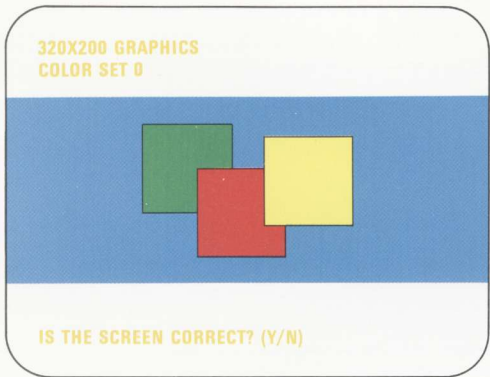

- 10** Did the following appear on your screen, and are the colors correct?





**YES** - Press  then  and go to the next step.

**NO** - Press  then . Record the error message and have the unit that contains the adapter serviced.

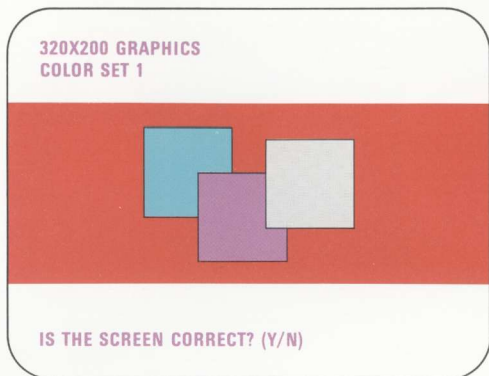
- 11** Did the following appear on your screen, and are the colors correct?





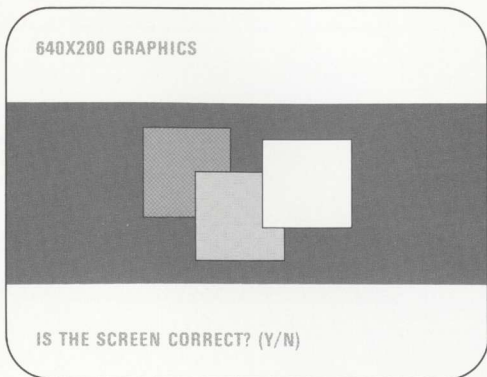

**YES** - Press  then  and go to the next step.

**NO** - Press  then  . Record the error message and have the unit that contains the adapter serviced.

## 12 Did the following appear on your screen?



**YES** - Press  then  and go to the next step.

**NO** - Press  then  . Record the error message and have the unit that contains the adapter serviced.

- 13 Did the following appear on your screen, and are the colors correct?

640X200 16-COLOR GRAPHICS







BLACK BLUE GREEN CYAN RED MAG BROWN WHITE



DARK LGHT LGHT LGHT LGHT LGHT YELLOW INT  
GRAY BLUE GREEN CYAN RED MAG WHITE

IS THE SCREEN CORRECT? (Y/N)

YES - Press  then  and go to the next step.

NO - Press  then  . Record the

error message and have the unit that contains the adapter serviced.



- 14** The following will appear if you have only 64KB of memory on your Enhanced Graphics Adapter.

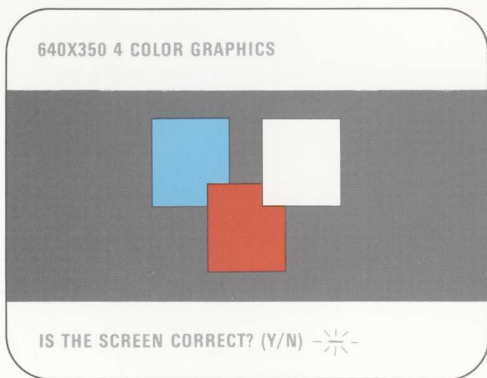

Did the following appear on your screen?

**NO** - Go to the next step.

**YES** - Is the screen as shown below and are the colors correct?



**YES** - Press  then  and go to the next step.

**NO** - Press  then . Record the

error message and have the unit that contains the adapter serviced.



- 15** The following will appear if you have 128 or more KB of memory on your Enhanced Graphics Adapter.

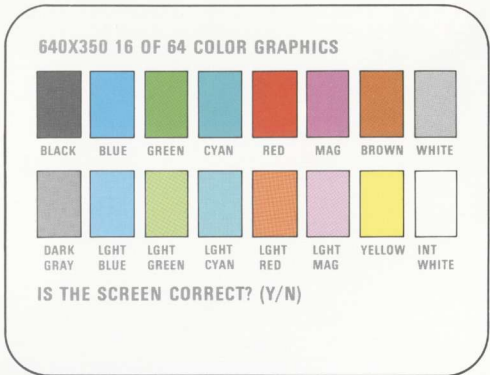

Did the following appear on your screen?

**NO** - Go to the next step.

**YES** - Is the screen as shown below and are the colors correct?



**YES** - Press  then  and go to the next step.

**NO** - Press  then  . Record the

error message and have the unit that contains the adapter serviced.





**19** Do you have an IBM Color Display connected to your Enhanced Graphics Adapter?

**NO** - Go to Step 31.

**YES** - Did the following appear on your screen (ignore color problems)?

DISPLAY ATTRIBUTES

THIS LINE IS AT NORMAL INTENSITY.

THIS LINE IS INTENSIFIED.



THIS LINE IS IN REVERSE VIDEO.

THIS LINE IS BLINKING.

	BLUE
	GREEN
	CYAN
	RED
	MAGENTA
	BROWN
	WHITE

IS THE SCREEN CORRECT ? (Y/N)

**YES** - Go to the next step.

**NO** - Press  then . Record the

error message and have the unit that contains the adapter serviced.

- 20** Examine the Display attributes screen. Are the colors correct?

**Note:** There should be two different shades of each color.

DISPLAY ATTRIBUTES

THIS LINE IS AT NORMAL INTENSITY.



THIS LINE IS INTENSIFIED.

THIS LINE IS IN REVERSE VIDEO.

THIS LINE IS BLINKING.

	BLUE
	GREEN
	CYAN
	RED
	MAGENTA
	BROWN
	WHITE

IS THE SCREEN CORRECT ? (Y/N)

**YES** - Press  then  and go to the next step.

**NO** - Have the display serviced.









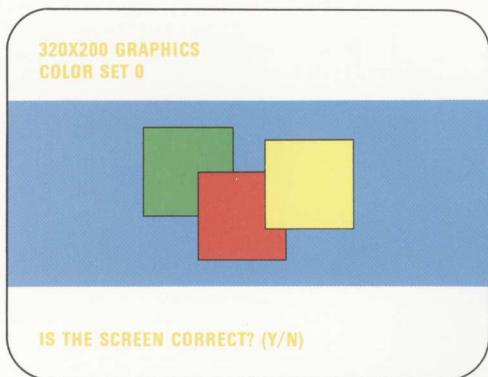

24. Did the following appear on your screen, and are the colors correct?





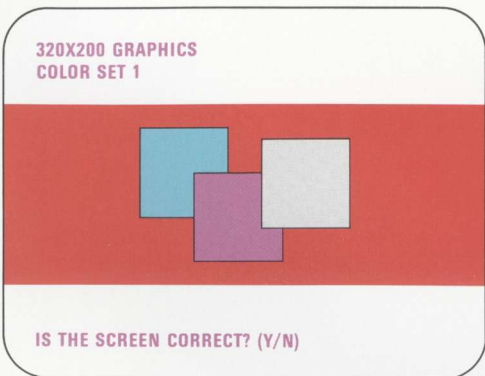

YES - Press  then  and go to the next step.

NO - Press  then . Record the error message and have the unit that contains the adapter serviced.

- 25** Did the following appear on your screen, and are the colors correct?





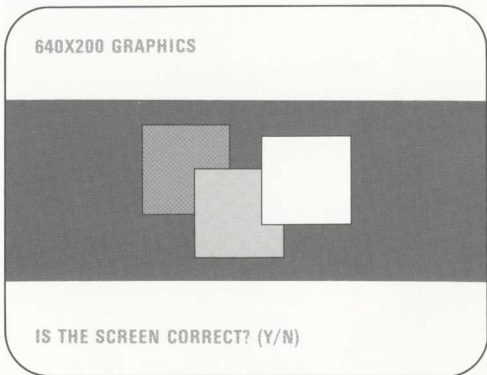

**YES** - Press  then  and go to the next step.

**NO** - Press  then . Record the error message and have the unit that contains the adapter serviced.

**26** Did the following appear on your screen?





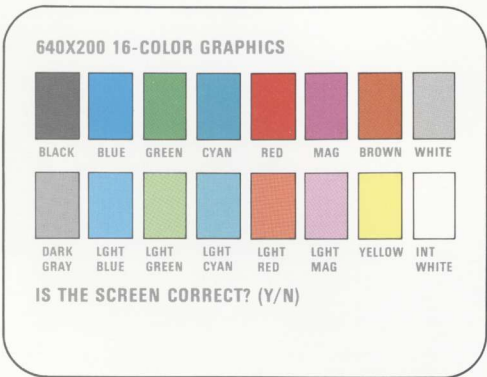

**YES** - Press  then  and go to the next step.

**NO** - Press  then . Record the error message and have the unit that contains the adapter serviced.

- 27 Did the following appear on your screen, and are the colors correct?



**YES** - Press  then  and go to the next step.

**NO** - Press  then . Record the error message and have the unit that contains the adapter serviced.





**31** Do you have an IBM Monochrome Display connected to your Enhanced Graphics Adapter?

**NO** - Continue with the next Test.

**YES** - Did the following appear on your screen?

**DISPLAY ATTRIBUTES**

**THIS LINE IS AT NORMAL INTENSITY**



**THIS LINE IS INTENSIFIED**



**THIS LINE IS IN REVERSE VIDEO**

**THIS LINE IS BLINKING**

**THIS LINE IS UNDERLINED**

**IS THE SCREEN CORRECT? (Y/N)**

**YES** - Press  then  and go to the next step.

**NO** - Press  then . Record the

error message and have the unit that contains the adapter serviced.







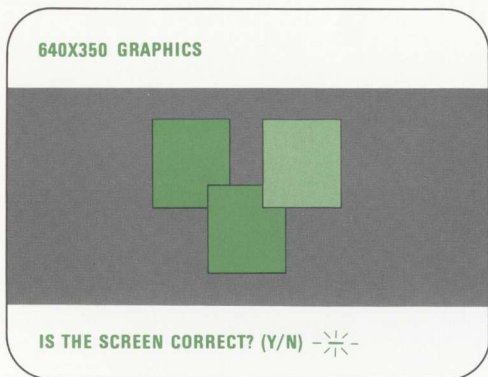

### 34 Did the following appear on your screen?



**Note:** The right block is blinking.

**YES** - Press  then  and go to the next step.

**NO** - Press  then . Record the error message and have the unit that contains the adapter serviced.





# Test 9010

If your IBM Enhanced Color Display does not work properly, this test will help you decide if the display or the system unit needs to be serviced.

If your IBM Enhanced Color Display requires service, it must be returned *with* the Power Cord.

- 1 Set the Power control to On.

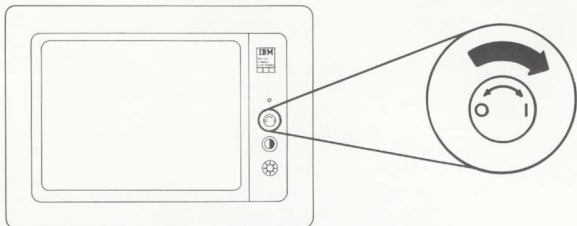

**2** Is the Power-On indicator lit?

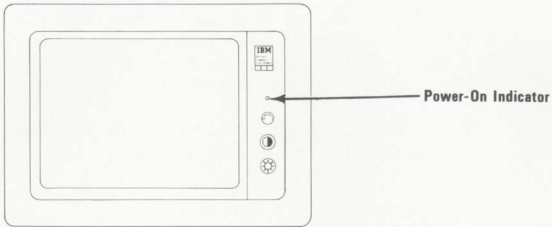

**YES** - Go to the next step.

**NO** - Check that the power cord is plugged into a functioning wall outlet and into the rear of the display. If so, have the display serviced.

**3** Set the Power switch on the system unit (and expansion unit, if attached) to Off.

- 4** Turn the Brightness control fully clockwise.

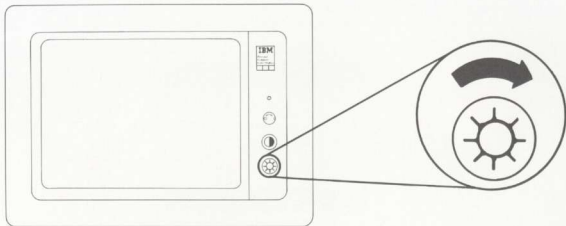

- 5** Turn the Mode 1 Vertical Size control fully counterclockwise. A black area should appear across the top and the bottom of the screen.

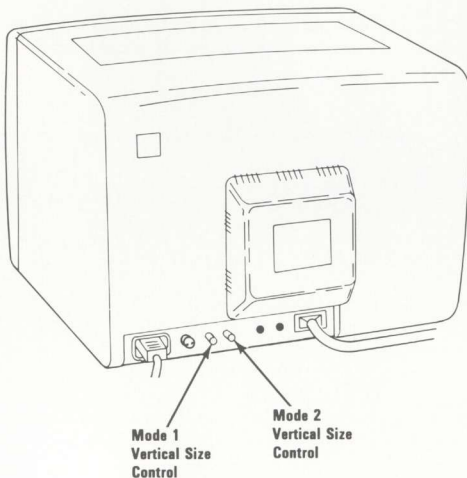

- 6** Does a black area appear across the top and the bottom of the screen?

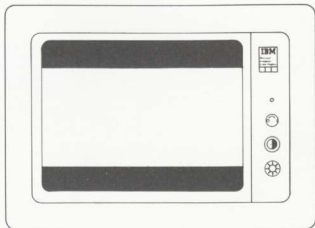

**YES** - Go to the next step.

**NO** - Have the display serviced.

- 7** Are the black areas at the top and bottom of the the screen approximately equal in size?

**YES** - Go to the next step.

**NO** - Have the display serviced.

- 8** Turn the Mode 1 Vertical Size control clockwise until the black areas at the top and bottom of the screen just disappear. If one of the black areas disappears before the other, continue to turn the control until the second black area is gone.
- 9** Is the screen all white?
- YES - Go to Step 14.
- NO - Go to the next step.
- 10** Set the display's Power control to Off.
- 11** Disconnect the display's signal cable from the system unit or expansion unit.

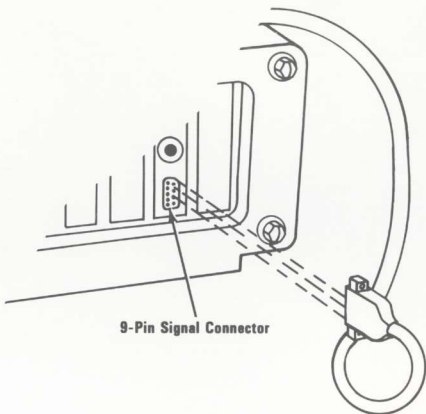

- 12** Set the Power control on the display to On.

**13** Is the screen all white?

**YES** - Have the unit that the display was attached to serviced.

**NO** - Have the display serviced.

**14** Turn the Brightness control counterclockwise until the white area of the screen starts to disappear. Pull out and turn the Contrast control counterclockwise; the brightness of the screen should decrease. Turn the Contrast control clockwise, the brightness of the screen should increase. Push the Contrast control in, the screen should return to a preset value.

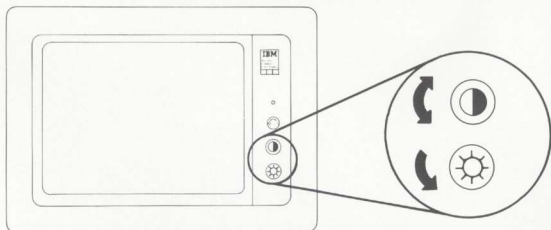

**15** Did the Contrast control work correctly?

**YES** - Go to the next step.

**NO** - Have the display serviced.

- 16** While watching the screen, set the Power switch on the expansion unit (if attached) to On. Then set the system unit's Power switch to On.
- 17** Did the screen change when the Power switch was set to On? (The change may be instantaneous.)
- YES** - Go to the next step.
- NO** - Have the unit the display is attached to serviced.
- 18** Wait for the power-on self test (POST) to end. The IBM Personal Computer BASIC message, with a blinking cursor, will appear (if a diskette is not inserted, or an operating system is not automatically loaded from a fixed disk drive).

The IBM Personal Computer Basic  
Version CX.XX Copyright IBM Corp XXXX  
XXXXX Bytes free  
OK

1LIST 2RUN 3LOAD" 4SAVE 5CONT 6LPT1 '7TRON 8TROFF 9KEY 0SCREEN

- 19** Is your screen blank?
- NO** - Go to the next step.
- YES** - Have the unit that the display was attached to serviced.
- 20** Is your screen steady?
- YES** - Go to the next step.
- NO** - Have the display serviced.
- 21** Look at the screen. Does it have white characters on a dark background?
- YES** - Go to Step 27.
- NO** - Go to the next step.
- 22** Set the Power switch on the system unit (and expansion unit, if attached) to Off.
- 23** Set the display's Power control to Off.

- 24** Disconnect the display's signal cable from the system unit or expansion unit.

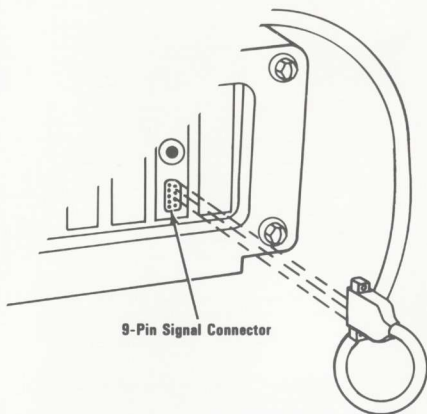

- 25** Set the display's Power control to On.
- 26** Is the screen all white?
- YES** - Have the unit that the display was attached to serviced.
- NO** - Have the display serviced.

- 27** Turn the Brightness control fully counterclockwise.

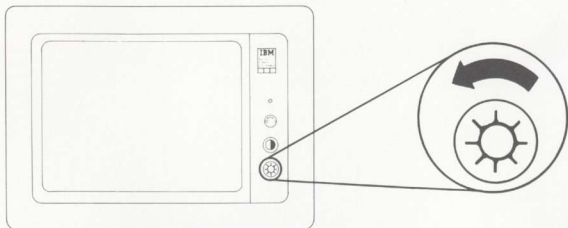

- 28** Does the intensity of the characters decrease?  
YES - Go to the next step.  
NO - Have the display serviced.

- 24** Disconnect the display's signal cable from the system unit or expansion unit.

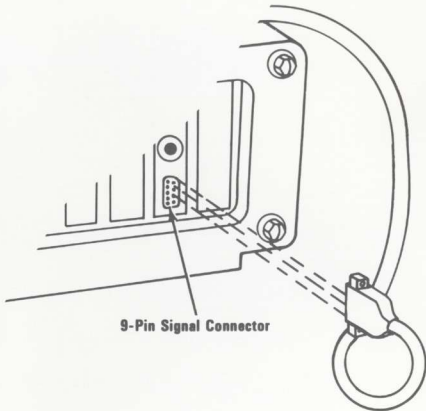

- 25** Set the display's Power control to On.

- 26** Is the screen all white?

**YES** - Have the unit that the display was attached to serviced.

**NO** - Have the display serviced.

- 27** Turn the Brightness control fully counterclockwise.

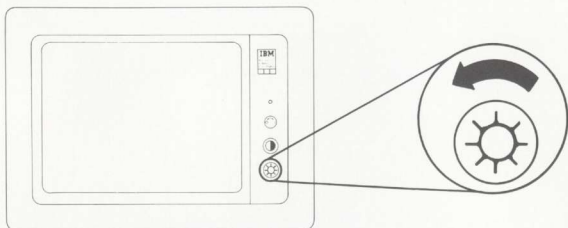

- 28** Does the intensity of the characters decrease?

**YES** - Go to the next step.

**NO** - Have the display serviced.

- 29** Adjust the Brightness and Contrast controls to your preferred settings.

Look at the following examples.



**Too Dim**



**Too Wide**



**Too Narrow**



**Out of Focus**



**Shrunk**



**Characters shifted left or right or up and down off the display area**



**Tilted**

- 30** Is the problem similar to one of the examples?

**YES** - Have your display serviced.

**NO** - Go to "Diagnostic Testing" earlier in this section.

**Notes:**

# Test 500

**1** Do you have a color display or TV attached to an IBM Color/Graphics Adapter?

**NO** - Continue with the next Test.

**YES** - Did the following appear on your screen?

## DISPLAY ATTRIBUTES

THIS LINE IS AT NORMAL INTENSITY.



THIS LINE IS INTENSIFIED.



THIS LINE IS IN REVERSE VIDEO.

THIS LINE IS BLINKING.

	BLUE
	GREEN
	CYAN
	RED
	MAGENTA
	BROWN
	WHITE

IS THE SCREEN CORRECT ? (Y/N)

**YES** - Press  then  and go to the next step.

**NO** - Press  and then . Record the error message and have the unit that contains the adapter serviced.



# Power-On Self Test (POST)

- 1 Turn the Brightness and Contrast controls fully clockwise. When the first screen presentation appears, adjust the controls for eye comfort.

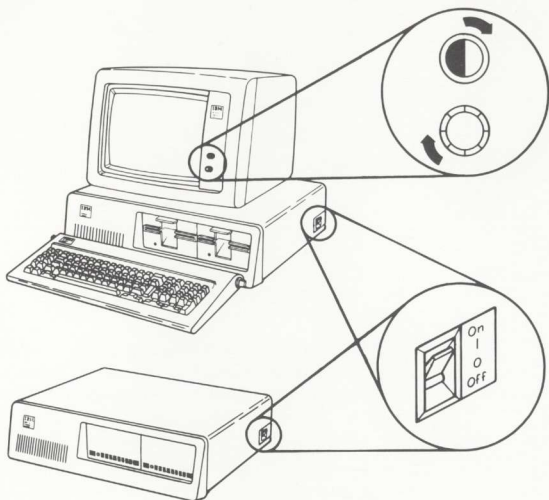

- 2 Set the Power switches on all attached devices to On.
- 3 If the expansion unit is attached, set its Power switch to On.
- 4 Set the system unit's Power switch to On.

POST will finish in 13 to 90 seconds, depending on the amount of memory in your system. Normally, you will receive the following responses:

- A Look in the upper left-hand corner of the screen during POST.

If you have the Personal Computer, a blinking cursor should appear.

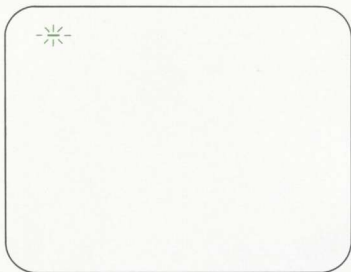

If you have the Personal Computer XT, a number should appear and continue to increase in value until it equals the amount of memory in your system.



- B One short beep will be heard when the test finishes successfully.
- C The "IBM Personal Computer BASIC" message should appear. (If, at the end of POST, a program from a diskette, or an operating system from the fixed disk drive, is automatically loaded, the first screen presentation of the program or operating system should appear).

```
The IBM Personal Computer Basic  
Version CX.XX Copyright IBM Corp XXXX  
XXXXX Bytes free  
OK
```

```
1LIST 2RUN 3LOAD" 4SAVE 5CONT 6LPT1 '7TRON 8TROFF 9KEY 0SCREEN
```

Did A, B, and C occur?

**YES** - Go to "Formatting a Diskette" on page Start 40-1.

**NO** - Personal Computer users go to "Personal Computer POST Errors" on the next page.

Personal Computer XT users go to "Personal Computer XT POST Errors" on Start 30-9.

## Personal Computer POST Errors

In the following examples, find your screen response and audio response, then follow the instructions in the box marked "Action."

**Warning:** If the instructions are to have a unit serviced, and that unit has a fixed disk drive, we recommend that you back up all disk files onto diskettes. Normal shipping and handling can result in permanent loss of data on your fixed disk drives. Refer to the IBM *DOS* manual for a description of the Backup command.

## Example 1

### Screen Response

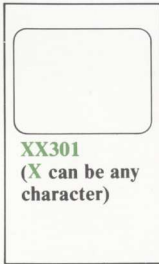

### Audio Response

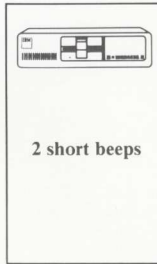

### Action



**Note:** Ensure the keyboard is connected correctly and check for any objects or foreign material on the keyboard. If error 301 still appears after the keyboard has been serviced, have the system unit serviced.

## Example 2

### Screen Response



### Audio Response

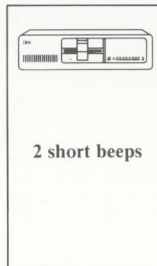

### Action

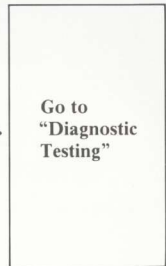

### Example 3

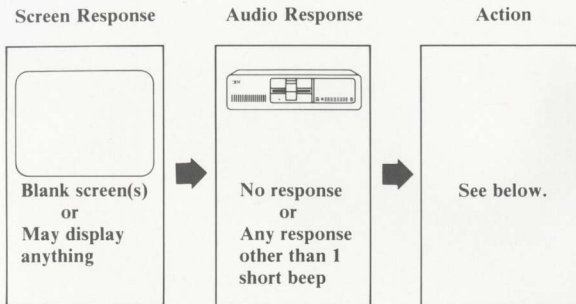

Do you have an expansion unit attached?

**NO** - Have the system unit serviced.

**YES** - Do the following:

1. Set the Power switches on the system unit and expansion unit to Off.
2. Set the Power switches on all attached devices to Off.
3. Disconnect the expansion unit cable from the system unit.
4. Set the Power switch on the system unit to On.

If the error is the same, have the system unit serviced.  
If the error changes, have the expansion unit and its cable serviced.

#### Example 4 (Color Display Only)

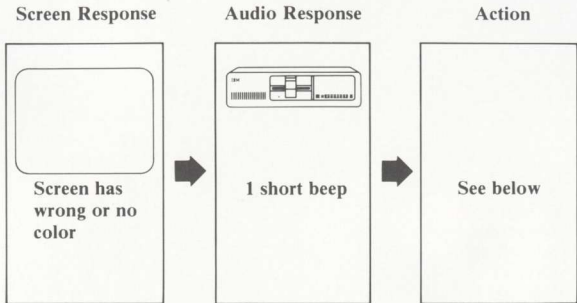

If you are using a TV as your display, verify that the color is correct by disconnecting your TV from the unit and operating the TV normally. Also, ensure your TV is compatible with the NTSC standard. If you have an IBM Color Display, go to "Test 9000". If you have an IBM Enhanced Color Display to "Test 9010".

## Example 5

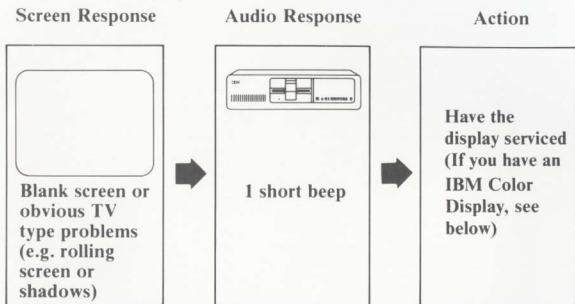

If you have an IBM Color Display, go to "Test 9000".  
If you have an IBM Enhanced Color Display go to "Test 9010".

# Personal Computer XT POST Errors

In the following examples, find your screen response and audio response, then follow the instructions in the box marked "Action."

**Warning:** If the instructions are to have a unit serviced, and that unit has a fixed disk drive, we recommend that you back up all disk files onto diskettes. Normal shipping and handling can result in permanent loss of data on your fixed disk drives. Refer to the IBM *DOS* manual for a description of the Backup command.

## Example 1

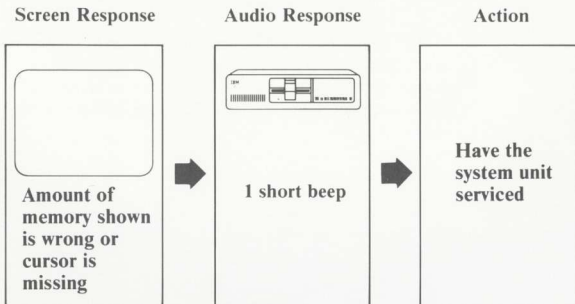

## Example 2

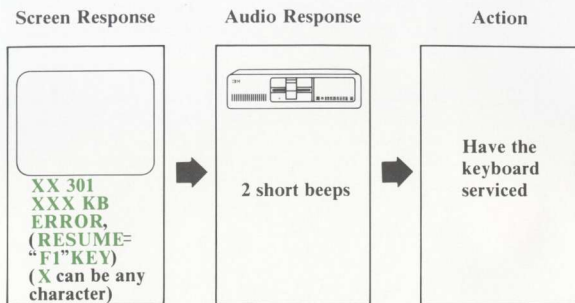

**Note:** Ensure the keyboard is connected correctly and check for any objects or foreign material on the keyboard. If error 301 still appears after the keyboard has been serviced, have the system unit serviced.

## Example 3

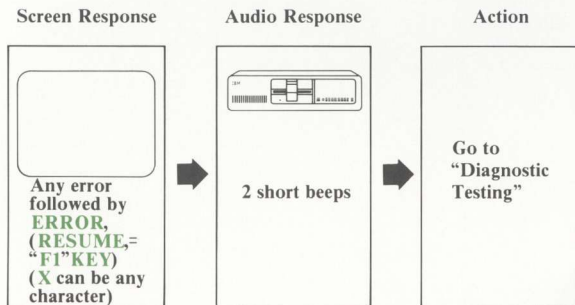

#### Example 4

#### Screen Response

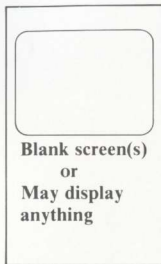

#### Audio Response

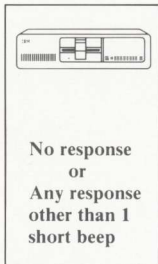

#### Action

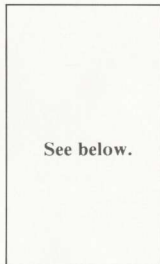

Do you have an expansion unit attached?

**NO** - Have the system unit serviced.

**YES** - Do the following:

1. Set the Power switches on the system unit and expansion unit to Off.
2. Set the Power switches on all attached devices to Off.
3. Disconnect the expansion-unit cable from the system unit.
4. Set the Power switch on the system unit to On.

If the error is the same, have the system unit serviced.  
If the error changes, have the expansion unit and its cable serviced.

### Example 5 (Color Display Only)

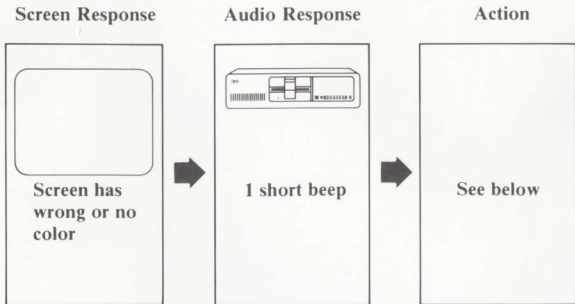

If you are using a TV as your display, verify that the color is correct by disconnecting your TV from the unit and operating the TV normally. Also, ensure your TV is compatible with NTSC standard. If you have an IBM Color Display, go to "Test 9000". If you have an IBM Enhanced Color Display, go to "Test 9010".

## Example 6

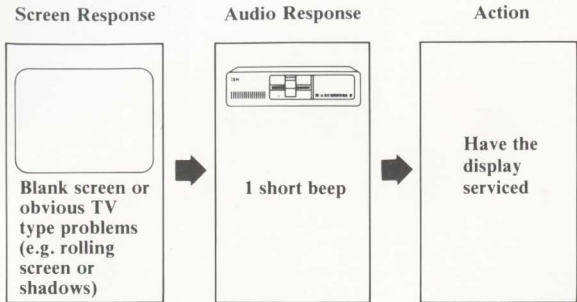

If you have an IBM Color Display, go to "Test 9000".  
If you have an IBM Enhanced Color Display, go to "Test 9010".

Notes:

# Switch Setting Charts

## System Board Switch Settings

The switches on the system board are set as shown in the following figure. These settings are necessary for the system to address the attached components, and to specify the amount of memory installed on the system board.

**Warning:** Before you change any switch settings, make a note of how the switches are presently set.

### Switch Block 1

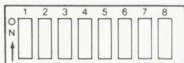

Switch	Function
1,7,8	Number of 5-1/4 inch diskette drives installed (with the PC-XT Switch 1 must be Off)
2	Coprocessor
3,4	System board memory switches
5,6	Type(s) of display adapter(s) installed

## Switch Block 2



Switch	Function
--------	----------

1,2,3,4,5	Amount of memory options installed
-----------	------------------------------------

6,7,8	Always in the Off position
-------	----------------------------

## Number of 5-1/4 Inch Diskette Drives Installed

1 - Drive



2 - Drives



## Type(s) of Display Adapter(s) Installed

**Warning:** If an IBM Monochrome Display is attached to your system, it must be attached to either a Monochrome and Printer Adapter or an Enhanced Graphics Adapter. Switches 5 and 6 must be set correctly for the type of adapter installed. Failure to follow this warning may result in damage to your display.



IBM Enhanced Graphics Adapter (alone or with another adapter) or NO adapter at all.

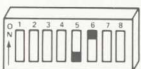

IBM Color/Graphics Adapter in 40x25 Color mode.

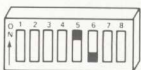

IBM Color/Graphics Adapter in 80x25 Color mode.

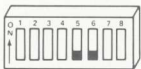

IBM Monochrome and Printer Adapter or the IBM Monochrome and Printer Adapter and the IBM Color/Graphics Adapter together.

**Note:** The 40x25 mode means the screen is 40 characters wide by 25 lines high. 80x25 is 80 characters wide by 25 lines high. The 80x25 mode, when used with home televisions and various displays, can cause loss of character quality.



# Switch Setting Charts

## System Board Switch Settings

The switches on the system board are set as shown in the following figure. These settings are necessary for the system to address the attached components, and to specify the amount of memory installed on the system board.

**Warning:** Before you change any switch settings, make a note of how the switches are presently set.

Switch Block 1

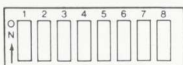

Switch	Function
1,7,8	Number of 5-1/4 inch diskette drives installed (with the PC-XT Switch 1 must be Off)
2	Coprocessor
3,4	System board memory switches
5,6	Type(s) of display adapter(s) installed

## System Board Memory Switch Settings

The following figure shows the settings for switches 3 and 4 for the amount of memory on the system board.

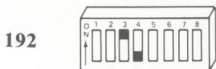

## Number of 5-1/4 Inch Diskette Drives Installed

1 - Drive



2 - Drives



## Type(s) of Display Adapter(s) Installed

**Warning:** If an IBM Monochrome Display is attached to your system, it must be attached to either a Monochrome and Printer Adapter or an Enhanced Graphics Adapter. Switches 5 and 6 must be set correctly for the type of adapter installed. Failure to follow this warning may result in damage to your display.

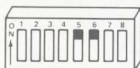

IBM Enhanced Graphics Adapter (alone or with another adapter) or NO adapter at all.

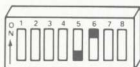

IBM Color/Graphics Adapter in 40x25 Color mode.

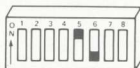

IBM Color/Graphics Adapter in 80x25 Color mode.

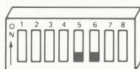

IBM Monochrome and Printer Adapter or the IBM Monochrome and Printer Adapter and the IBM Color/Graphics Adapter together.

**Note:** The 40x25 mode means the screen is 40 characters wide by 25 lines high. 80x25 is 80 characters wide by 25 lines high. The 80x25 mode, when used with home televisions and various displays, can cause loss of character quality.

# Type(s) of Display Adapter(s) Installed

**Warning:** If an IBM Monochrome Display is attached to your system, it must be attached to either a Monochrome and Printer Adapter or an Enhanced Graphics Adapter. Switches 5 and 6 must be set correctly for the type of adapter installed. Failure to follow this warning may result in damage to your display.

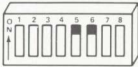

IBM Enhanced Graphics Adapter (alone or with another adapter) or NO adapter at all.



IBM Color/Graphics Adapter in 40x25 Color mode.

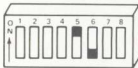

IBM Color/Graphics Adapter in 80x25 Color mode.

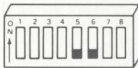

IBM Monochrome and Printer Adapter or the IBM Monochrome and Printer Adapter and the IBM Color/Graphics Adapter together.

**Note:** The 40x25 mode means the screen is 40 characters wide by 25 lines high. 80x25 is 80 characters wide by 25 lines high. The 80x25 mode, when used with home televisions and various displays, can cause loss of character quality.

## 5-1/4 Inch Diskette Drives

The following figures show how switches 7 and 8 must be set for the number of diskette drives installed. :artwork=1p 'art=4040'

1 Drive



2 Drives



## Type(s) of Display Adapter(s) Installed

**Warning:** If an IBM Monochrome Display is attached to your system, it must be attached to either a Monochrome and Printer Adapter or an Enhanced Graphics Adapter. Switches 5 and 6 must be set correctly for the type of adapter installed. Failure to follow this warning may result in damage to your display.

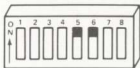

IBM Enhanced Graphics Adapter (alone or with another adapter) or NO adapter at all.

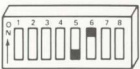

IBM Color/Graphics Adapter in 40x25 Color mode.



IBM Color/Graphics Adapter in 80x25 Color mode.

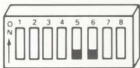

IBM Monochrome and Printer Adapter or the IBM Monochrome and Printer Adapter and the IBM Color/Graphics Adapter together.

**Note:** The 40x25 mode means the screen is 40 characters wide by 25 lines high. 80x25 is 80 characters wide by 25 lines high. The 80x25 mode, when used with home televisions and various displays, can cause loss of character quality.

# Memory Option Switches

## (16KB-64KB CPU) System Board

16K Total Memory



32K Total Memory



48K Total Memory



64K Total Memory

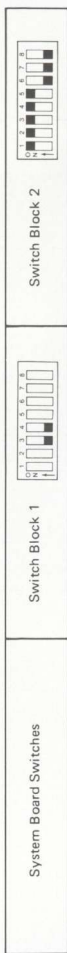

## Type(s) of Display Adapter(s) Installed

**Warning:** If an IBM Monochrome Display is attached to your system, it must be attached to either a Monochrome and Printer Adapter or an Enhanced Graphics Adapter. Switches 5 and 6 must be set correctly for the type of adapter installed. Failure to follow this warning may result in damage to your display.

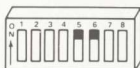

IBM Enhanced Graphics Adapter (alone or with another adapter) or NO adapter at all.



IBM Color/Graphics Adapter in 40x25 Color mode.



IBM Color/Graphics Adapter in 80x25 Color mode.

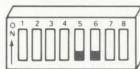

IBM Monochrome and Printer Adapter or the IBM Monochrome and Printer Adapter and the IBM Color/Graphics Adapter together.

**Note:** The 40x25 mode means the screen is 40 characters wide by 25 lines high. 80x25 is 80 characters wide by 25 lines high. The 80x25 mode, when used with home televisions and various displays, can cause loss of character quality.

## 5-1/4 Inch Diskette Drives

The following figures show how switches 1, 7 and 8 must be set for the number of diskette drives installed.

### Switch Block 1

0 Drives



1 Drive



2 Drives

