

JVC AV-N29220 SERVICE MANUAL

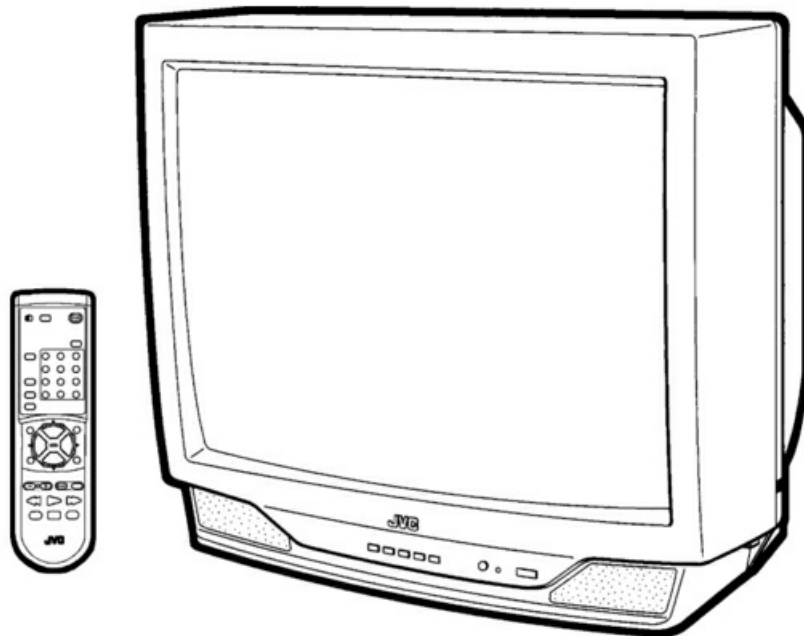

Quick Links

[Specifications](#)

Table of Contents

[Table of Contents](#)

[SPECIFICATIONS](#)

[SAFETY PRECAUTIONS](#)

[FEATURES](#)

[MAIN DIFFERENCE LIST](#)

[HOW TO IDENTIFY MODELS](#)

[FUNCTIONS](#)

[SPECIFIC SERVICE INSTRUCTIONS](#)

[disassembly procedure](#)

[SERVICE ADJUSTMENTS](#)

[adjustment items](#)

[sound mode](#)

[replacement of chip component](#)

[Other ManualsLib Projects](#)

JVC

SERVICE MANUAL

COLOR TELEVISION

AV-N29220_{/R}
AV-N29220_{/S}

BASIC CHASSIS
FV4

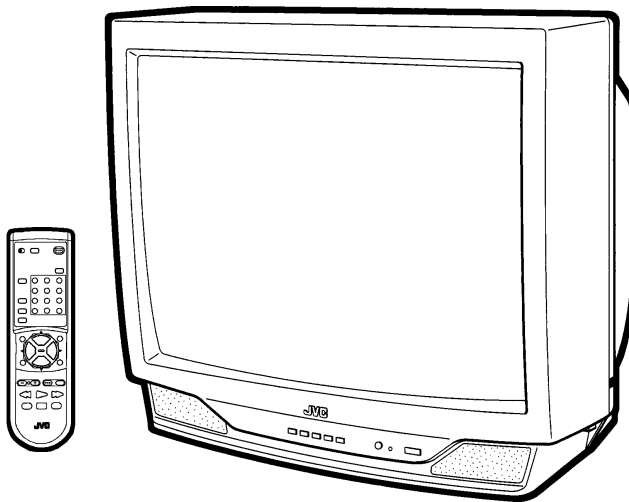

CONTENTS

■ SPECIFICATIONS	2
■ SAFETY PRECAUTIONS	3
■ FEATURES	4
■ MAIN DIFFERENCE LIST	4
■ HOW TO IDENTIFY MODELS	4
■ FUNCTIONS	5
■ SPECIFIC SERVICE INSTRUCTIONS	6
■ SERVICE ADJUSTMENTS	10
■ PARTS LIST	25
★ OPERATING INSTRUCTIONS	
★ STANDARD CIRCUIT DIAGRAM	2-1

SPECIFICATIONS

Items	Contents	
	AV-N29220/R	AV-N29220/S
Dimensions (W × H × D)	654mm × 593mm × 495mm	
Mass	31.1 kg	
TV RF System	CCIR(M)	
Color Sound System	NTSC, BTSC System (Multi Channel Sound)	
TV Receiving Channels and Frequency		
VL Band	(02~06) 54MHz~88MHz	
VH Band	(07~13) 174MHz~216MHz	
UHF Band	(14~69) 470MHz~806MHz	
CATV Receiving Channels and Frequency		
Low Band	(02~06, A-8) by (02~06&01)	
High Band	(07~13) by (07~13)	
Mid Band	(A~1) by (14~22)	
Super Band	(J~W) by (23~36)	
Hyper Band	(W+1~W+28) by (37~64)	
Ultra Band	(W+29~W+84) by (65~125)	
Sub Mid Band	(A8, A4~A1) by (01, 96~99)	
TV/CATV Total Channel	180 Channels	
Intermediate Frequency		
Video IF Carrier	45.75MHz	
Sound IF Carrier	41.25MHz (4.5MHz)	
Color Sub Carrier	3.58MHz	
Power Input	120V AC, 60Hz	
Power Consumption	113W	
Picture Tube	29" (68cm) Measured Diagonally	
High Voltage	29kV ± 1kV (at zero beam current)	
Speaker	5 × 9cm Oval type × 2	
Audio Power Output	1.2W × 2	
Input		
Video Input	1Vp-p, 75 Ω (RCA pin jack)	
Audio Input (R/L)	500mVrms (-4dBs), High Impedance (RCA pin jack)	
S-Video	Y: 1Vp-p Positive (negative sync provided, when terminated with 75 Ω) C: 0.286Vp-p (burst signal, when terminated with 75 Ω)	
Variable Audio Output (R/L)	More than 0~1550mVrms (+6dBs) Low impedance (400Hz when modulated 100%) (RCA pin jack)	
Antenna terminal	75 Ω (VHF/UHF) Terminal, F-Type Connector	
Remote Control Unit	RM-C306 (AA/R6/UM-3 battery × 2)	

Design & specifications are subject to change without notice.

SAFETY PRECAUTIONS

- The design of this product contains special hardware, many circuits and components specially for safety purposes. For continued protection, no changes should be made to the original design unless authorized in writing by the manufacturer. Replacement parts must be identical to those used in the original circuits. Qualified personnel should perform Service only.
- Alterations of the design or circuitry of the products should not be made. Any design alterations or additions will void the manufacturer's warranty and will further relieve the manufacturer of responsibility for personal injury or property damage resulting therefrom.
- Many electrical and mechanical parts in the products have special safety-related characteristics. These characteristics are often not evident from visual inspection nor can the protection afforded by them necessarily be obtained by using replacement components rated for higher voltage, wattage, etc. Replacement parts that have these special safety characteristics are identified in the parts list of Service manual. **Electrical components having such features are identified by shading on the schematics and by (Δ) on the parts list in Service manual.** The use of a substitute replacement which does not have the same safety characteristics as the recommended replacement part shown in the parts list of Service manual may cause shock, fire, or other hazards.
- Don't short between the LIVE side ground and ISOLATED (NEUTRAL) side ground or EARTH side ground when repairing.**
Some model's power circuit is partly different in the GND. The difference of the GND is shown by the LIVE : (⊥) side GND, the ISOLATED(NEUTRAL) : (⊕) side GND and EARTH : (⊕) side GND. Don't short between the LIVE side GND and ISOLATED(NEUTRAL) side GND or EARTH side GND and never measure with a measuring apparatus (oscilloscope etc.) the LIVE side GND and ISOLATED(NEUTRAL) side GND or EARTH side GND at the same time.
If above note will not be kept, a fuse or any parts will be broken.
- If any repair has been made to the chassis, it is recommended that the B1 setting should be checked or adjusted (See ADJUSTMENT OF B1 POWER SUPPLY).
- The high voltage applied to the picture tube must conform with that specified in Service manual. Excessive high voltage can cause an increase in X-Ray emission, arcing and possible component damage, therefore operation under excessive high voltage conditions should be kept to a minimum, or should be prevented. If severe arcing occurs, remove the AC power immediately and determine the cause by visual inspection (incorrect installation, cracked or melted high voltage harness, poor soldering, etc.). To maintain the proper minimum level of soft X-Ray emission, components in the high voltage circuitry including the picture tube must be the exact replacements or alternatives approved by the manufacturer of the complete product.
- Do not check high voltage by drawing an arc. Use a high voltage meter or a high voltage probe with a VTVM. Discharge the picture tube before attempting meter connection, by connecting a clip lead to the ground frame and connecting the other end of the lead through a 10kΩ 2W resistor to the anode button.
- When service is required, observe the original lead dress. Extra precaution should be given to assure correct lead dress in the high voltage circuit area. Where a short circuit has occurred, those components that indicate evidence of overheating should be replaced. Always use the manufacturer's replacement components.

9. Isolation Check

(Safety for Electrical Shock Hazard)

After re-assembling the product, always perform an isolation check on the exposed metal parts of the cabinet (antenna terminals, video/audio input and output terminals, Control knobs, metal cabinet, screw heads, earphone jack, control shafts, etc.) to be sure the product is safe to operate without danger of electrical shock.

(1) Dielectric Strength Test

The isolation between the AC primary circuit and all metal parts exposed to the user, particularly any exposed metal part having a return path to the chassis should withstand a voltage of 3000V AC (r.m.s.) for a period of one second.

(. . . Withstand a voltage of 1100V AC (r.m.s.) to an appliance rated up to 120V, and 3000V AC (r.m.s.) to an appliance rated 200V or more, for a period of one second.)

This method of test requires test equipment not generally found in the service trade.

(2) Leakage Current Check

Plug the AC line cord directly into the AC outlet (do not use a line isolation transformer during this check.). Using a "Leakage Current Tester", measure the leakage current from each exposed metal part of the cabinet, particularly any exposed metal part having a return path to the chassis, to a known good earth ground (water pipe, etc.). Any leakage current must not exceed 0.5mA AC (r.m.s.).

However, in tropical area, this must not exceed 0.2mA AC (r.m.s.).

● Alternate Check Method

Plug the AC line cord directly into the AC outlet (do not use a line isolation transformer during this check.). Use an AC voltmeter having 1000 ohms per volt or more sensitivity in the following manner. Connect a 1500Ω 10W resistor paralleled by a 0.15μF AC-type capacitor between an exposed metal part and a known good earth ground (water pipe, etc.). Measure the AC voltage across the resistor with the AC voltmeter. Move the resistor connection to each exposed metal part, particularly any exposed metal part having a return path to the chassis, and measure the AC voltage across the resistor. Now, reverse the plug in the AC outlet and repeat each measurement. Any voltage measured must not exceed 0.75V AC (r.m.s.). This corresponds to 0.5mA AC (r.m.s.).

However, in tropical area, this must not exceed 0.3V AC (r.m.s.). This corresponds to 0.2mA AC (r.m.s.).

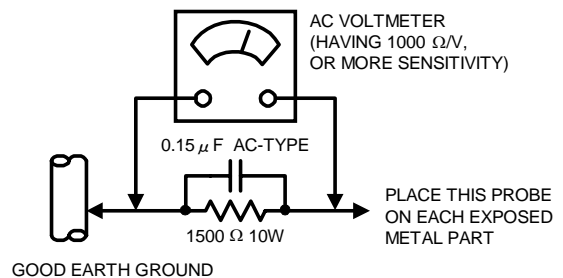

FEATURES

- New chassis design enables use of a single board with simplified circuitry.
- Provided with miniature tuner (TV/CATV).
- Multifunctional remote control permits picture adjustment.
- Adoption of the CHANNEL GUARD function prevents the specific channels from being selected, unless the "ID number" is key in.
- I²C bus control utilizes single chip ICs.
- Adoption of the VIDEO STATUS function.
- Adoption of the ON/OFF TIMER function.
- Built-in V-CHIP system.
- With 75 Ω V/U in common (F-Type) ANT Terminal.
- SLEEP TIMER for setting in real time.
- Closed-caption broadcasts can be viewed.
- Audio Video input terminal.
- Built-in MTS system.
- Built-in HYPER-SURROUND system.
- S-VIDEO input terminal for taking best advantage of Super VHS.
- Variable Audio output terminal.
- 2 LINE Digital Comb filter Improved picture quality.

MAIN DIFFERENCE LIST

△	Model name	AV-N29220/R	AV-N29220/S
	Parts Name		
	MAIN PWB	SFV-1071A-M2	SFV-1074A-M2
△	PICTURE TUBE (ITC)	A68ADT25X881	A68QDN891X001

HOW TO IDENTIFY MODELS

The difference between AV-N29220/R and AV-N29220/S is in the PICTURE TUBE.

As the result of the difference in PICTURE TUBE, the MAIN PWB also differ.

△	MODEL	AV-N29220/R	AV-N29220/s
△	Parts name		
△	RATING LABEL	<p>GQ20001-001A-A</p> <p>INDICATED AV-N29220</p> <p>INDICATED "R"</p>	<p>←</p> <p>INDICATED AV-N29220</p> <p>INDICATED "S"</p>

FUNCTIONS

FRONT CONTROL KEYS

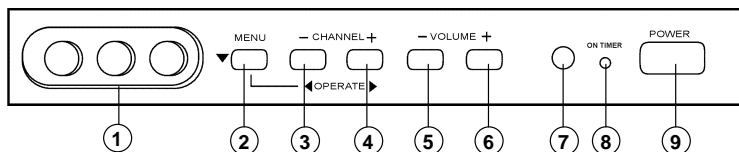

- ① INPUT 2 (V, L/MONO, R) terminals
- ② MENU button
- ③ CHANNEL - (Operate◀) button
- ④ CHANNEL + (Operate▶) button
- ⑤ VOLUME - button
- ⑥ VOLUME + button
- ⑦ REMOCON window
- ⑧ INDICATOR lamp (TIMER / POWER)
- ⑨ POWER button

REMOTE CONTROL UNIT

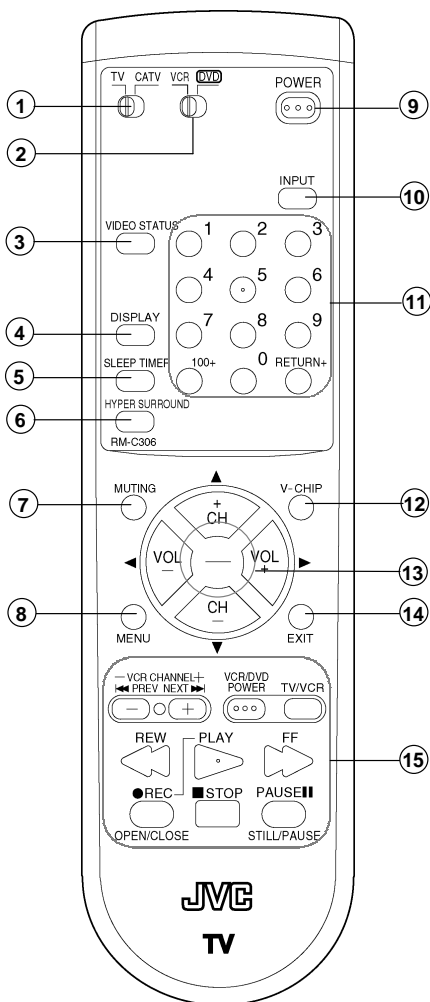

- ① TV / CATV select key
- ② VCR / DVD select keys
- ③ VIDEO STATUS key
- ④ DISPLAY key
- ⑤ SLEEP TIMER key
- ⑥ HYPER SURROUND key
- ⑦ MUTING key
- ⑧ MENU key
- ⑨ POWER key
- ⑩ INPUT key
- ⑪ CHANNEL select key
- ⑫ V-CHIP key
- ⑬ FUNCTION key
- ⑭ EXIT key
- ⑮ VCR / DVD control key

REAR TERMINAL

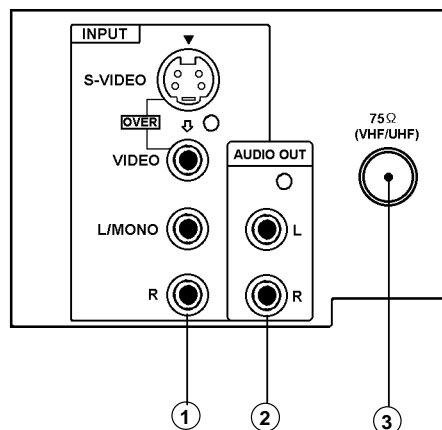

- ① INPUT1 (S-VIDEO, V, L/MONO, R) terminal
- ② AUDIO OUTPUT terminal (Variable)
- ③ ANTENNA terminal

SPECIFIC SERVICE INSTRUCTIONS

DISASSEMBLY PROCEDURE

REMOVING THE REAR COVER

1. Unplug the power supply cord.
2. Remove the 7 screws marked (A) and 2 screws marked (B) as shown in Fig.1.
3. Withdraw the REAR COVER toward you.

[CAUTION]

- When reinstalling the rear cover, carefully push it inward after inserting the MAIN PWB into the rear cover groove.

REMOVING THE MAIN PW BOARD

- After removing the rear cover.
1. Pick this side of the MAIN PWB and raise one slightly, take off the PWB stopper marked (C) from the cabinet bottom.
 2. Pull out the MAIN PWB as it is.
(If necessary, take off the wire clamp and connectors, etc.)

REMOVING THE SPEAKER

- After removing the MAIN PW board.
1. Remove the 2 screws marked (D) as shown in Fig.1.
 2. Withdraw the speaker backward.
 3. Follow the same steps when removing the other hand speaker.

CHECKING THE MAIN PW BOARD

1. To check the back side of the MAIN PW Board.
 - 1) Pull out the MAIN PWB. (Refer to REMOVING THE MAIN PWB).
 - 2) Erect the chassis vertically so that you can easily check the back side of the MAIN PW Board.

[CAUTION]

- When erecting the MAIN PWB, be careful so that there will be no contacting with other PW Board.
- Before turning on power, make sure that the CRT earth wire and other connectors are properly connected.

WIRE CLAMPING AND CABLE TYING

1. Be sure clamp the wire.
2. Never remove the cable tie used for tying the wires together.
Should it be inadvertently removed, be sure to tie the wires with a new cable tie.

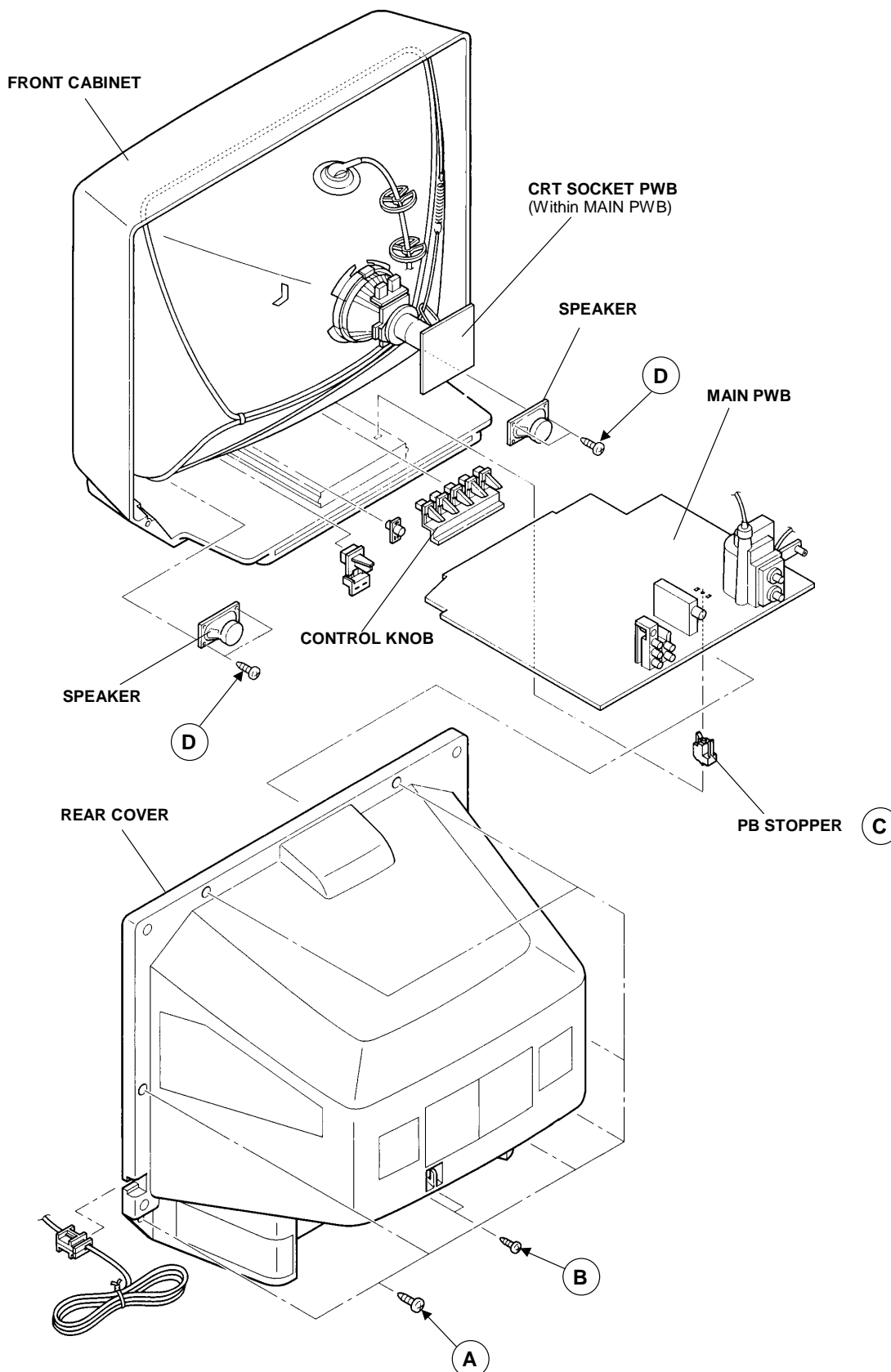

Fig.1

MEMORY IC REPLACEMENT

1. Memory IC

This model use a memory IC.

This memory IC stores data for proper operation of the video and deflection circuits.

When replacing, be sure to use an IC containing this (initial value) data.

2. Memory IC replacement procedure

Procedure	Screen display
<p>(1) Power off Switch off the power and disconnect the power cord from the outlet.</p>	
<p>(2) Replace the memory IC Initial value must be entered into the new IC.</p>	
<p>(3) Power on Connect the power cord to the outlet and switch on the power.</p>	
<p>(4) System constant check and setting</p> <ol style="list-style-type: none"> 1) Press SLEEP TIMER key and, while the indication of "SLEEP TIMER 0 MIN." is being displayed, press DISPLAY key and VIDEO STATUS key on the remote control unit simultaneously. 2) The SERVICE MENU screen of Fig.1 is displayed. 3) While the SERVICE MENU is displayed, again simultaneously press the DISPLAY and VIDEO STATUS keys to display the Fig.2 SYSTEM CONSTANT screen. 4) Refer to the SYSTEM CONSTANT table and check the setting items. Where these differ, select the setting item with the MENU UP/DOWN key and adjust the setting with the MENU LEFT/RIGHT keys. (The letters of the selected item are displayed in yellow.) 5) After adjusting, release the MENU LEFT/RIGHT key to store the setting value. 6) Press the EXIT key twice to return the normal screen. 	 <p style="text-align: center;">Fig.1</p>
<p>(5) Receive channel setting Refer to the OPERATING INSTRUCTIONS (USER'S GUIDE) and set the receive channels (Channels Preset) as described.</p>	 <p style="text-align: center;">Fig.2</p>
<p>(6) User settings Check the user setting items according to Table 2. Where these do not agree, refer to the OPERATING INSTRUCTIONS (USER'S GUIDE) and set the items as described.</p>	<p style="text-align: right;">Indicated Model No.</p>
<p>(7) SERVICE MENU setting Verify what to set in the SERVICE MENU, and set whatever is necessary.(Fig.1) Refer to the SERVICE ADJUSTMENT for setting.</p>	

TABLE 1 (System Constant setting)

Setting item	Setting content	Setting value	
		AV-N29220/R	AV-N29220/S
MODEL	Display the each application model	Comfortable model name	
V-CHIP		YES	YES
CAN V-CHIP		YES	YES

TABLE 2 (User setting value)

Setting item	Setting value
1. Use remote controller keys	
POWER	OFF
CHANNEL	CH 02
CHANNEL PRESET	See OPERATING INSTRUCTIONS.
VOLUME	10
INPUT (TV/VIDEO)	TV
DISPLAY	OFF
SLEEP TIMER	0
VIDEO STATUS	STANDARD
HYPER SURROUND	OFF
2. Setting of MENU	
TINT	CENTER
COLOR	CENTER
PICTURE	CENTER
BRIGHT	CENTER
DETAIL	CENTER
NOISE MUTING	ON
SET VIDEO STATUS	ALL CENTER
BASS	CENTER
TREBLE	CENTER
BALANCE	CENTER
MTS	STEREO
TV SPEAKER	ON
SET CLOCK	Unnecessary to set
ON/OFF TIMER	NO
LANGUAGE	SPANISH
CLOSED CAPTION	OFF
BACKGROUND	BLACK
AUTO TUNER SETUP	TUNER MODE : AIR
CHANNEL SUMMARY	Unnecessary to set
V-CHIP	OFF
SET LOCK CODE	Unnecessary to set

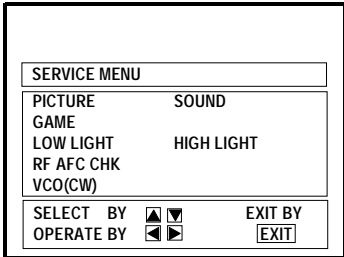
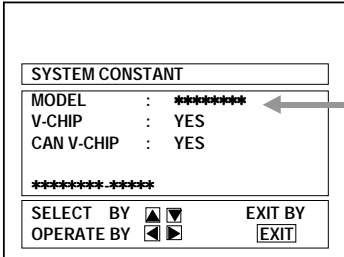
SERVICE ADJUSTMENTS

ADJUSTMENT PREPARATION

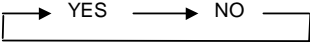
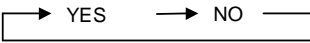
1. You can make the necessary adjustments for this unit with either the Remote Control Unit or With the adjustment tools and parts as given below.
2. Adjustment with the Remote Control Unit is made on the basis of the initial setting values, however, the new setting values which set the screen to its optimum condition may differ from the initial settings.
3. Make sure that AC power is turned on correctly.
4. Turn on the power for set and test equipment before use, and start the adjustment procedures after waiting at least 30 minutes.
5. Unless otherwise specified, prepare the most suitable reception or input signal for adjustment.

6. Never touch any adjustment parts which are not specified in the list for this adjustment - variable resistors, transformers, condensers, etc.
7. Presetting before adjustment.
Unless otherwise specified in the adjustment instructions, preset the following functions with the remote control unit:

VIDEO STATUS	STANDARD
BASS, TREBLE, BALANCE	CENTER
HYPER SURROUND	OFF
TINT, COLOR, PICTURE, BRIGHT, DETAIL	CENTER

ADJUSTMENT EQUIPMENT

1. DC voltmeter (or digital voltmeter)
2. Oscilloscope
3. Signal generator (Pattern generator) [NTSC]
4. Remote control unit
5. TV audio multiplex signal generator.
6. Frequency counter

ADJUSTMENT ITEMS

Adjustment items	Adjustment items	Adjustment items
B1 POWER SUPPLY	WHITE BALANCE (Low Light)	MTS INPUT LEVEL check
IF VCO	WHITE BALANCE (High Light)	MTS STEREO VCO
RF. AGC	SUB BRIGHT	MTS SAP VCO
FOCUS	SUB CONTRAST	MTS FILTER check
V. SIZE	SUB COLOR	MTS SEPARATION
H. POSITION	SUB TINT	

ADJUSTMENT LOCATIONS

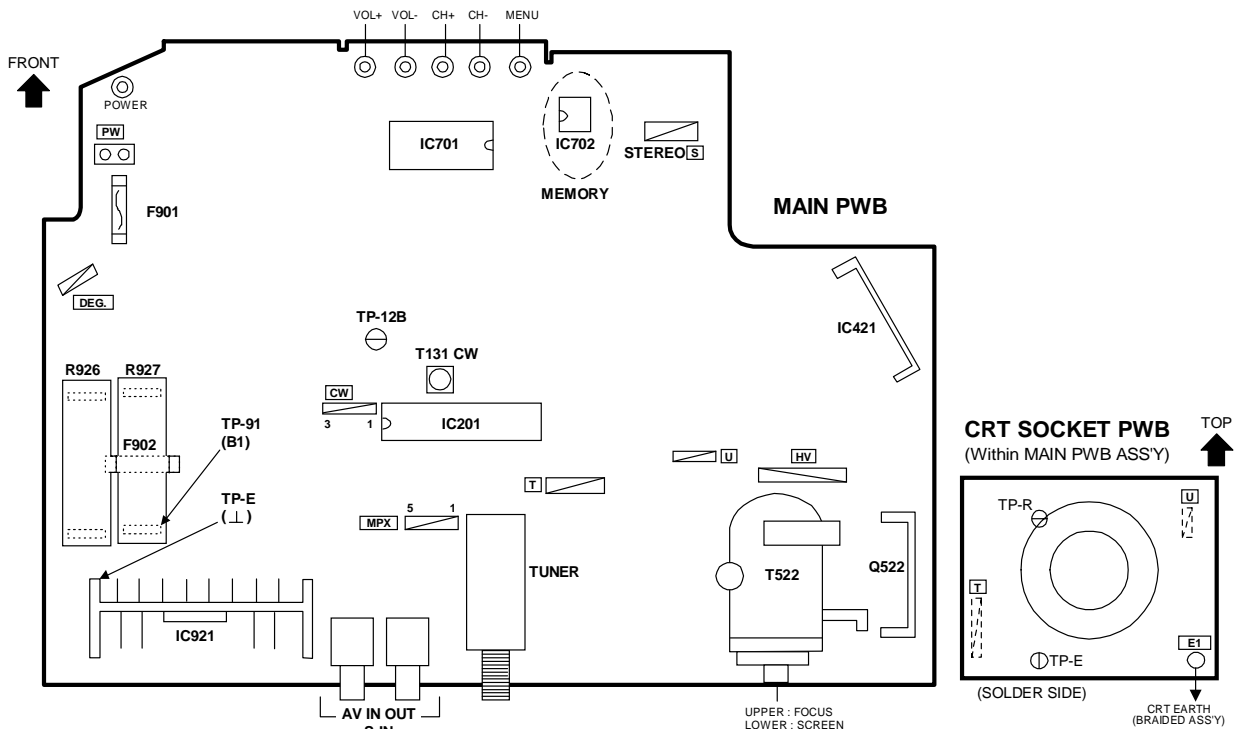

BASIC OPERATION OF SERVICE MENU

1. TOOL OF SERVICE MENU OPERATION

Operate the SERVICE MENU with the REMOTE CONTROL UNIT.

2. SERVICE MENU ITEMS

In general, basic setting (adjustments) items or verifications are performed in the SERVICE MENU.

- PICTURE This sets the setting values (adjustment values) of the VIDEO/CHROMA and DEFLECTION circuits.
- SOUND This sets the setting values (adjustment values) of the AUDIO circuit.
- GAME This is used when the GAME MODE is adjusted.
- LOW LIGHT This sets the setting values (adjustment values) of the WHITE BALANCE circuit.
- HIGH LIGHT This sets the setting values (adjustment values) of the WHITE BALANCE circuit.
- RF AFC CHK This is used when the IF VCO is adjusted. **[Do not adjust]**
- VCO (CW) This is used when the IF VCO is adjusted.

3. Basic Operations of the SERVICE MENU

(1) How to enter the SERVICE MENU.

Press **SLEEP TIMER** key and, while the indication of "**SLEEP TIMER 0 MIN.**" is being displayed, press **DISPLAY** key and **VIDEO STATUS** key on the remote control unit simultaneously to enter the **SERVICE MENU** screen ① shown in the next figure page.

(2) SERVICE MENU screen selection

Press the UP / DOWN key of the MENU to select any of the following items.

(The letters of the selected items are displayed in yellow.)

- PICTURE
- SOUND
- GAME
- LOW LIGHT
- HIGH LIGHT
- RF AFC CHK
- VCO(CW)

(3) Enter the any setting (adjustment) mode

● PICTURE and SOUND mode

- 1) If select any of PICTURE or SOUND items, and the LEFT / RIGHT key is pressed from SERVICE MENU (MAIN MENU), the screen ② will be displayed as shown in figure page later.
- 2) Then the UP / DOWN key is pressed, the PICTURE mode screen ③ or the SOUND mode screen ④ is displayed, and the PICTURE or SOUND setting can be performed.

● GAME, LOW LIGHT, HIGH LIGHT, RF AFC CHK and VCO (CW) mode

- 1) If select any of GAME / LOW LIGHT / HIGH LIGHT / RF AFC CHK / VCO (CW) items, and the LEFT / RIGHT key is pressed from SERVICE MENU (MAIN MENU), the screens ⑤ ⑥ ⑦ ⑧ ⑨ will be displayed as shown in figure page later.
- 2) Then the settings or verifications can be performed.

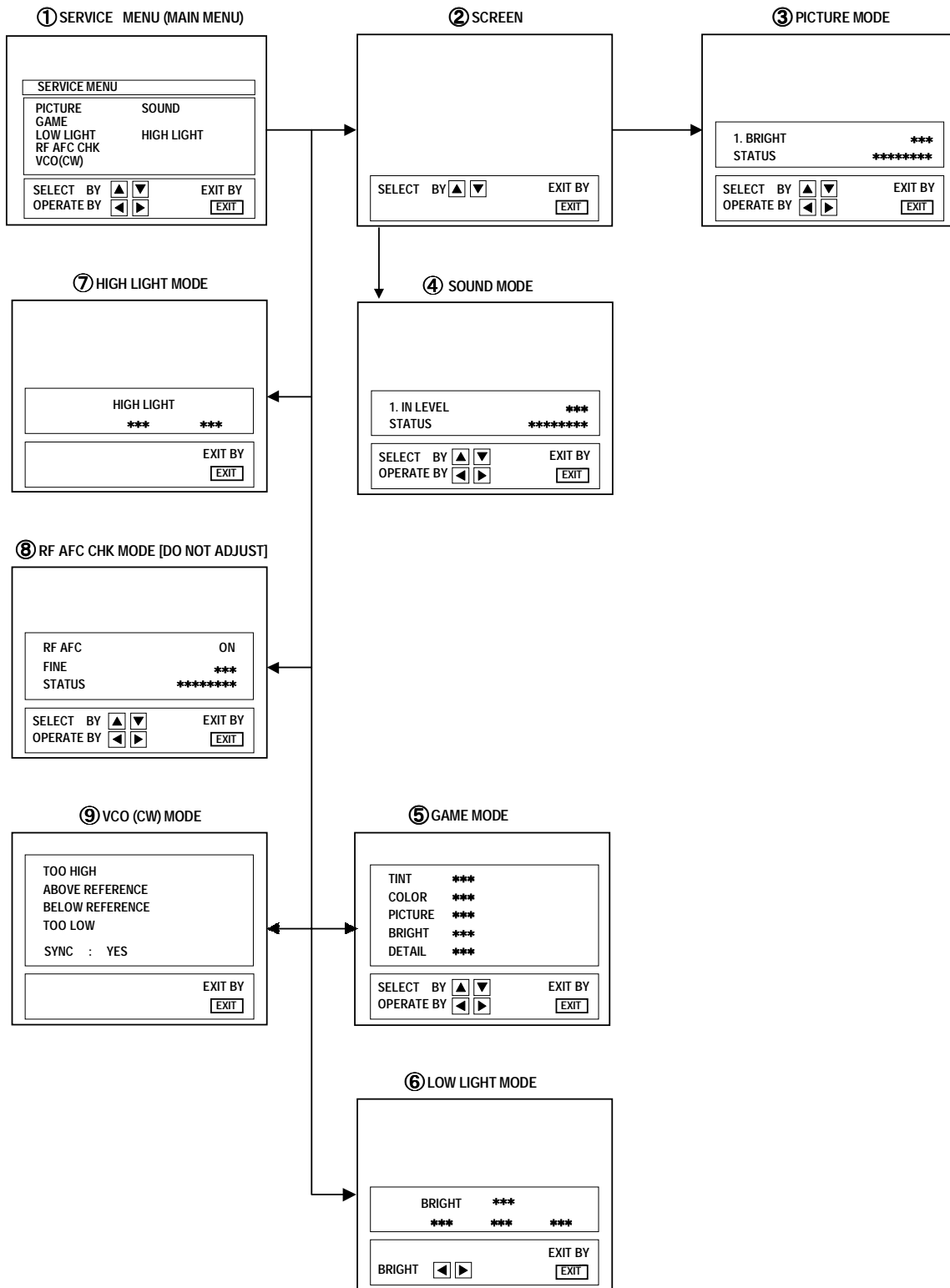

(4) Setting method

- 1) UP / DOWN key of the MENU
Select the SETTING ITEM.
- 2) LEFT / RIGHT key of the MENU
Setting (adjust) the SETTING VALUE of the SETTING ITEM.
When the key is released the SETTING VALUE will be stored (memorized).
- 3) EXIT key
Returns to the previous screen.

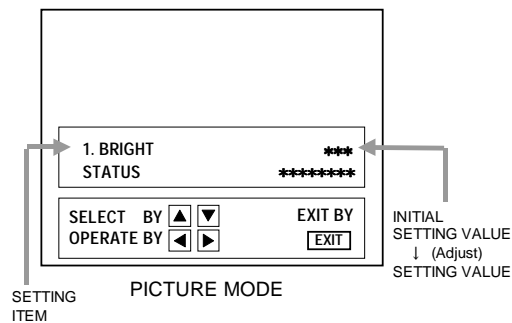

(5) Releasing SERVICE MENU

- 1) After returning to the SERVICE MENU upon completion of the setting (adjustment) work, press the EXIT key again.

- ★ The settings for LOW LIGHT and HIGH LIGHT are described in the WHITE BALANCE page of ADJUSTMENT.
- ★ The setting for VCO (CW) are described in the IF VCO page of ADJUSTMENT.

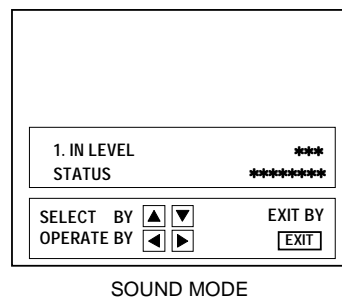

(The letter of the selected Items are displayed in yellow.)

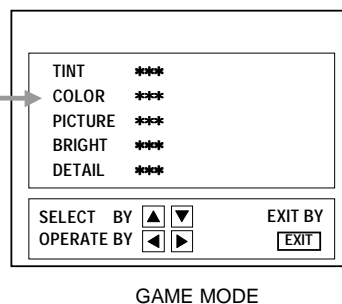

INITIAL SETTING VALUE OF SERVICE MENU

- Adjustment of the SERVICE MENU is made on the basis of the initial setting values; however, the new setting values which set the screen in its optimum condition may differ from the initial setting.
- Do not change the initial setting values of the setting (Adjustment) items not listed in "ADJUSTMENT" .

● PICTURE MODE

- ✧ The four setting items in the video mode No.7 EXT BRI., No.8 EXT PIC., No.11 EXT TINT and No.12 EXT COL. are linked to the items in the TV MODE No.1 BRIGHT, No.2 PICTURE, No.5 TINT and No.6 COLOR, respectively. When the setting items in the TV mode are adjusted, the values in the setting items in the video mode are revised automatically to the same values in the TV mode.(The initial setting values given in () are off-set values.)
- ✧ When the four items (No.7, 8, 11 and 12) are adjusted in the video mode, the setting values in each item are revised independently.

No.	Setting (Adjustment) items	Variable range	initial setting value
1.	BRIGHT	0 ~ 127	64
2.	PICTURE	0 ~ 127	77
3.	TV DTL(TV DETAIL)	0 ~ 63	26
4.	TV BPF(TV B.P.FILTER)	0 / 1	0
5.	TINT	0 ~ 127	66
6.	COLOR	0 ~ 127	50
7.	EXT BRI.(EXT.BRIGHT)	±25	(-2)
8.	EXT PIC.(EXT.PICTURE)	±25	(±0)
9.	EXT DTL(EXT.DETAIL)	0 ~ 63	26
10.	EXT BPF(EXT.B.P.FILTER)	0 / 1	0
11.	EXT TINT	±25	(±0)
12.	EXT COL.(EXT.COLOR)	±25	(+1)
13.	V SIZE	0 ~ 63	38
14.	V CENT.(V.CENTER)	0 ~ 7	0
15.	H POS.(H.POSITION)	0 ~ 31	18
16.	OSD HP (OSD H POSITION)	0 ~ 31	23
17.	OSD VP (OSD V POSITION)	0 ~ 15	14
18.	H. AFC	0 / 1	0
19.	RF AGC	0 ~ 63	40

● SOUND MODE

No.	Setting (Adjustment) item	Variable range	Initial setting value
1.	IN LEVEL (INPUT LEVEL)	0~63	29
2.	FH MON. (FM MONITOR)	0 / 1	0
3.	ST VCO (STEREO VCO)	0~63	20
4.	PILOT (PILOT CANCELER)	0 / 1	0
5.	FILTER	0~63	25
6.	LOW SEP. (LOW SEPARATION)	0~63	32
7.	HI SEP. (HI SEPARATION)	0~63	16
8.	5FH MON. (5FH MONITOR)	0 / 1	0
9.	SAP VCO	0~63	14
10.	FIL. OFF.	±10	0

● GAME MODE

Setting (Adjustment) item	Variable range	Initial setting value
TINT	± 20	± 0
COLOR	± 20	± 0
PICTURE	± 20	-10
BRIGHT	± 20	-5
DETAIL	± 15	+5

● LOW LIGHT MODE

Setting (Adjustment) item	Variable range	initial setting value
R CUTOFF	0 ~ 255	20
G CUTOFF	0 ~ 255	20
B CUTOFF	0 ~ 255	20

● HIGH LIGHT MODE

Setting (Adjustment) item	Variable range	initial setting value
G DRIVE	0 ~ 255	128
B DRIVE	0 ~ 255	128

● RF AFC CHECK MODE

Setting (Adjustment) item	Variable range	initial setting value
RF AFC	ON / OFF	ON
FINE	-77 ~ +77	$\pm \times \times$ (DO NOT ADJUST)

■ ADJUSTMENTS

B1 POWER SUPPLY

Item	Measuring instrument	Test point	Adjustment part	Description
Check of B1 POWER SUPPLY	DC Voltmeter	TP-91 (B1) TP-E(⊥)		<ol style="list-style-type: none"> 1. Receive a black-and-white signal. 2. Connect the DC Voltmeter to TP-91 (B1) and TP-E(⊥). 3. Confirm that the voltage is DC134V $\begin{matrix} +2V \\ -2.5V \end{matrix}$.

ADJUSTMENT OF VIDEO / DEF. CIRCUIT

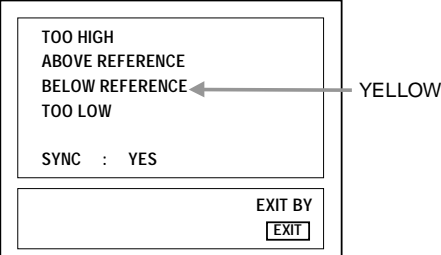
Item	Measuring instrument	Test point	Adjustment part	Description
IF VCO adjustment	Signal generator		CW TRANSF. (T131) [VCO(CW)] MODE	<ul style="list-style-type: none"> ● Under normal conditions, no adjustment is required. <ol style="list-style-type: none"> 1. Receive a NTSC broadcast. (use channels without offset frequency). 2. Select the VCO(CW) mode from the SERVICE MENU. 3. Confirm the color change (yellow) from "TOO HIGH" to "TOO LOW" by CW TRANSF. and "SYNC : YES" being shown on the screen. Then, adjust CW TRANSF. until "BELOW REFERENCE" mark turns yellow and confirm again "SYNC : YES" being shown on the screen.
				
RF. AGC adjustment			No.19 RF AGC	<ol style="list-style-type: none"> 1. Receive a broadcast. 2. Select "No.19 RF AGC" of the PICTURE MODE. 3. Press the MUTING key and turn off color. 4. With the MENU LEFT key, get noise in the screen picture. (0 side of setting value) 5. Press the MENU RIGHT key and stop when noise disappears from the screen. 6. Change to other channels and make sure that there is no irregularity. 7. Press the MUTING key and get color out.
FOCUS adjustment	Signal generator		FOCUS VR [In HVT]	<ol style="list-style-type: none"> 1. Receive a crosshatch signal. 2. While looking at the screen, adjust FOCUS VR so that the vertical and horizontal lines will be clear and in fine detail. 3. Make sure that the picture is in focus even when the screen gets darkened.

Item	Measuring instruments	Test point	Adjustment part	Description
V.SIZE Adjustment	Signal generator		No.13 V.SIZE	<ol style="list-style-type: none"> 1.Receive a crosshatch signal. 2.Select No.13 V.SIZE in the PICTURE MODE. 3.Set the initial setting value of No.13 V.SIZE with the LEFT / RIGHT key of the MENU. 4.Adjust No.13 V.SIZE until the vertical screen size is 92%.
<p>The diagram illustrates the vertical size adjustment. It shows a 10x10 grid of squares. A larger dashed rectangle represents the 'Screen size' with a width of 100% and a height of 92%. A smaller solid rectangle inside it represents the 'Picture size' with a width of 100% and a height of 100%. Arrows indicate the dimensions for both rectangles.</p>				
H.POSITION Adjustment	Signal generator		No.15 H.POS	<ol style="list-style-type: none"> 1.Receive a crosshatch signal. 2.Select the No.15 H.POS of the PICTURE MODE. 3.Set the initial setting value of the No.15 H.POS with the LEFT / RIGHT key of the MENU. 4.Adjust the No.15 H.POS until the screen will be horizontally centered.

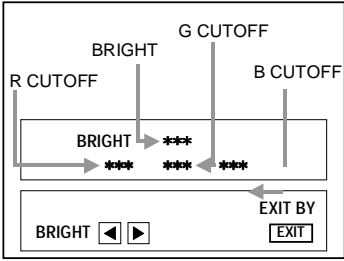
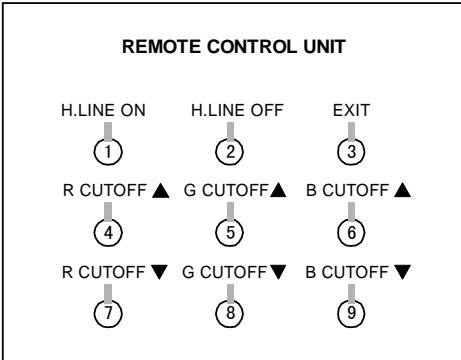
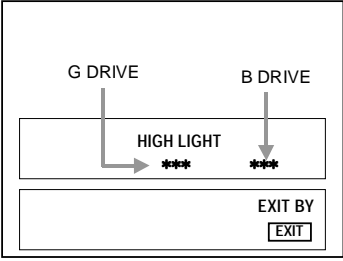
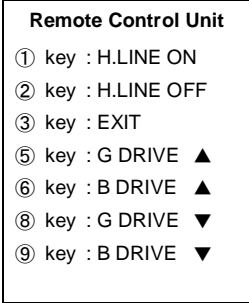
Item	Measuring instruments	Test point	Adjustment part	Description
<p>WHITE BALANCE (Low Light) Adjustment</p>	<p>Signal generator</p>		<p>BRIGHT</p> <p>R. CUTOFF</p> <p>G. CUTOFF</p> <p>B. CUTOFF</p> <p>SCREEN VR (In HVTI)</p>	<ol style="list-style-type: none"> 1. Receive a black-and-white signal.(Color off) 2. Select the LOW LIGHT MODE from the SERVICE MENU. 3. Set the initial setting value of BRIGHT with the LEFT / RIGHT key of the remote control unit. 4. Set the initial setting value of R CUTOFF, G CUTOFF and B CUTOFF with the ④ to ⑨ key of the remote control unit. 5. Display a single horizontal line by pressing the ① key of the remote control unit. 6. Turn the screen VR all the way to the left. 7. Turn the screen VR gradually to the right from the left until either one of the red, blue or green colors appears faintly. 8. Adjust the two colors which did not appear until the single horizontal line that is displayed becomes white using the ④ to ⑨ keys of the remote control unit. 9. Turn the screen VR to where the single horizontal line glows faintly. 10. Press the ② key to return to the regular screen. <p>* The ③ EXIT key is the cancel key for the WHITE BALANCE.</p>
<p style="text-align: center;">[LOW LIGHT] MODE</p>				
				
<p style="text-align: center;">REMOTE CONTROL UNIT</p>				
				
<p>WHITE BALANCE (High Light) Adjustment</p>	<p>Signal generator</p>		<p>G. DRIVE</p> <p>B. DRIVE</p>	<ol style="list-style-type: none"> 1. Receive a monoscope pattern signal. 2. Select the [HIGH LIGHT] MODE in the SERVICE MENU. 3. Set the initial setting value of G DRIVE and B DRIVE with the ⑤, ⑥, ⑧ and ⑨ keys of the remote control unit. 4. Adjust the screen until it becomes white using the ⑤, ⑥, ⑧ and ⑨ keys of the remote control unit. <p>* The ③ (EXIT) key is the cancel key for the WHITE BALANCE.</p>
<p style="text-align: center;">[HIGH LIGHT] MODE</p>				
				
<p style="text-align: center;">Remote Control Unit</p>				
				

Item	Measuring instruments	Test point	Adjustment part	Description
SUB BRIGHT Adjustment			No.1 BRIGHT	1.Receive a broadcast. 2.Select No.1 BRIGHT of the PICTURE MODE. 3.Set the initial setting value of the No.1 BRIGHT with the LEFT / RIGHT key of the MENU. 4.If the brightness is not best with the initial setting value, make fine adjustment of the No.1 BRIGHT until you get the optimum brightness.
SUB CONTRAST Adjustment			No.2 PICTURE	1.Receive a broadcast. 2.Select No.2 PICTURE of the PICTURE MODE. 3.Set the initial setting value of the No.2 PICTURE with the LEFT / RIGHT key of the MENU. 4.If the contrast is not best with the initial setting value, make fine adjustment of the No.2 PICTURE until you get the optimum contrast.
SUB COLOR adjustment	Signal generator Oscilloscope Remote control unit	TP-R TP-E(↕) [CRT SOCKET PWB]	No.6 COLOR	<p>[Method of adjustment without measuring instrument]</p> 1.Receive a broadcast. 2.Select "No.6 COLOR" of the PICTURE MODE. 3.Set the initial setting value of the "No.6 COLOR" with the LEFT/RIGHT key of the MENU. 4.If the color is not the best with the Initial setting value, make fine adjustment of the "No.6 COLOR" until you get the optimum color.
				<p>[Method of adjustment using measuring instrument]</p> 1.Input the full field color bar signal (75% white). 2.Select "No.6 COLOR" to the PICTURE MODE. 3.Set the initial setting value of the "No.6. COLOR" with the LEFT/RIGHT key of the MENU. 4.Connect the oscilloscope between TP-R and TP-E. 5.Adjust COLOR and bring the value of (A) in the illustration to the voltage +16V (V_{W-R}).

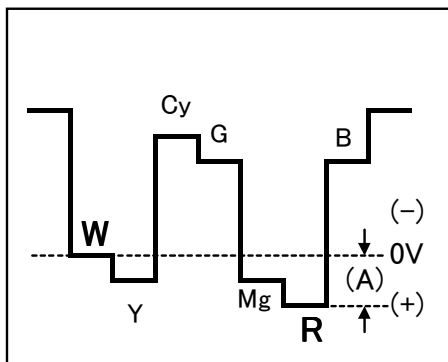

Item	Measuring instruments	Test point	Adjustment part	Description
SUB TINT adjustment	Signal generator Oscilloscope Remote control unit	TP-R TP-E(⏚) [CRT SOCKET PWB]	No.5 TINT	<p>[Method of adjustment without measuring instrument]</p> <ol style="list-style-type: none"> 1.Receive a broadcast. 2.Select "No.5 TINT" of the PICTURE MODE. 3.Set the initial setting value of the "No.5 TINT" with the LEFT/RIGHT key of the MENU. 4.If the tint is not the best with the initial setting value, make fine adjustment of the "No.5 TINT" until you get the optimum tint.
				<p>[Method of adjustment using measuring instrument]</p> <ol style="list-style-type: none"> 1.Input the full field color bar signal (75% white). 2.Select "No.5 TINT" to the PICTURE MODE. 3.Set the initial setting value of the "No.5 TINT" with the LEFT/RIGHT key to the MENU. 4.Connect the oscilloscope between TP-R and TP-E. 5.Adjust TINT and bring the value of (B) in the illustration to the voltage +9V (V_{W-Y}).

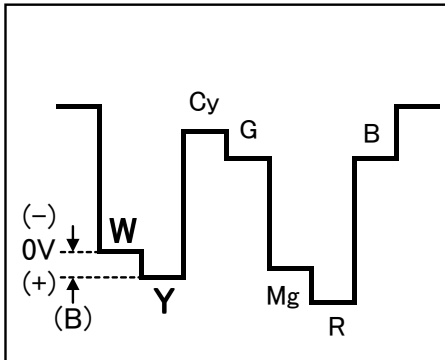

ADJUSTMENT OF MTS CIRCUIT

Item	Measuring instrument	Test point	Adjustment part	Description
MTS INPUT LEVEL check			No.1 IN LEVEL	<ol style="list-style-type: none"> 1.Select the "No.1 IN LEVEL" of the SOUND MODE. 2.Verify that the "No.1 IN LEVEL" is set at its initial setting value.
MTS STEREO VCO adjustment	Signal generator Frequency counter	R OUT [AUDIO OUT]	No.2 FH MON. No.3 ST VCO	<ol style="list-style-type: none"> 1.Receive a RF signal (nonmodulated sound signal) from the antenna terminal. 2.Select the "No.2 FH MON." of SOUND MODE, and change the setting value from 0 to 1. 3.Connect the Frequency Counter to R OUT RCA pin of the AUDIO OUT. 4.Select the "No.3 ST VCO". 5.Set the initial setting value of the "No.3 ST VCO" with the LEFT/RIGHT key of the menu. 6.Adjust the "No.3 ST VCO" so that the Frequency Counter will display $15.73\text{kHz} \pm 0.1\text{kHz}$. 7.Select the "No.2 FH MON." of the SOUND MODE, and reset the setting value from 1 to 0.

Item	Measuring instrument	Test point	Adjustment part	Description
MTS SAP VCO adjustment	Signal generator Frequency counter	[MPX] Connector [4] pin SDA [3] pin GND R OUT [AUDIO OUT]	No.8 5FH MON. No.9 SAP VCO	1.Receive a RF signal (non modulated sound signal) from the antenna terminal. 2.Connect between pin [4] of [MPX] connector and GND (Pin [3] of [MPX] connector) through 1MΩ Resistor. 3.Select the "No.8 5FH MON." of the SOUND MODE, and reset the setting value from 0 to 1. 4.Connect the Frequency Counter to R OUT RCA pin of the AUDIO OUT. 5.Select the "No.9 SAP VCO". 6.Set the initial setting value of "No.9 SAP VCO" with the LEFT/RIGHT key of the menu. 7.Adjust the "No.9 SAP VCO" so that the Frequency Counter will display 78.67kHz±0.5kHz. 8.Select the "No.8 5FH MON." of the SOUND MODE, and reset the setting value from 1 to 0.
MTS FILTER check			No.5 FILTER	1.Select the "No.5 FILTER" of the SOUND MODE. 2.Verify that the "No.5 FILTER" is set at its initial setting value.
MTS SEPARATION adjustment	TV audio multiplex signal generator Oscilloscope	L OUT R OUT [AUDIO OUT]	No.6 LOW SEP. No.7 HI SEP.	1.Input a stereo L signal (300Hz) from the TV audio multiplex signal generator to the antenna terminal. 2.Connect an oscilloscope to L OUT RCA pin of the AUDIO OUT, and display one cycle portion of the 300Hz signal. 3.Change the connection of the oscilloscope to R OUT RCA pin of the AUDIO OUT, and enlarge the voltage axis. 4.Select the "No.6 LOW SEP." of the SOUND MODE. 5.Set the initial setting value of the "No.6 LOW SEP." with the LEFT/RIGHT key of the menu. 6.Adjust the "No.6 LOW SEP." so that the stroke element of the 300Hz signal will become minimum. 7.Change the signal to 3kHz, and similarly adjust the "No.7 HI SEP.".

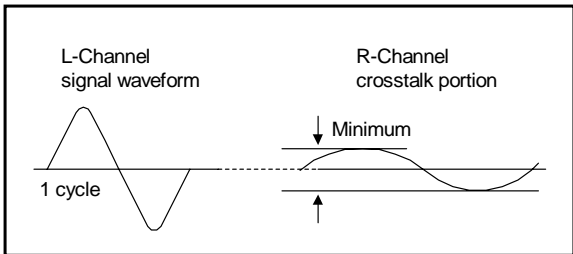

HOW TO CHECK THE HIGH VOLTAGE HOLD DOWN CIRCUIT

1. HIGH VOLTAGE HOLD DOWN CIRCUIT

After repairing the high voltage hold down circuit shown in Fig. 1.
This circuit shall be checked to operate correctly.

2. CHECKING OF THE HIGH VOLTAGE HOLD DOWN CIRCUIT

- (1) Turn the POWER SW ON.
- (2) As shown in Fig. 1, set the resistor (between connector 1 & 3).
- (3) Make sure that the screen picture disappears.
- (4) Temporarily unplug the power cord.
- (5) Remove the resistor (between connector 1 & 3).
- (6) Again plug the power cord, make sure that the normal picture is displayed on the screen.

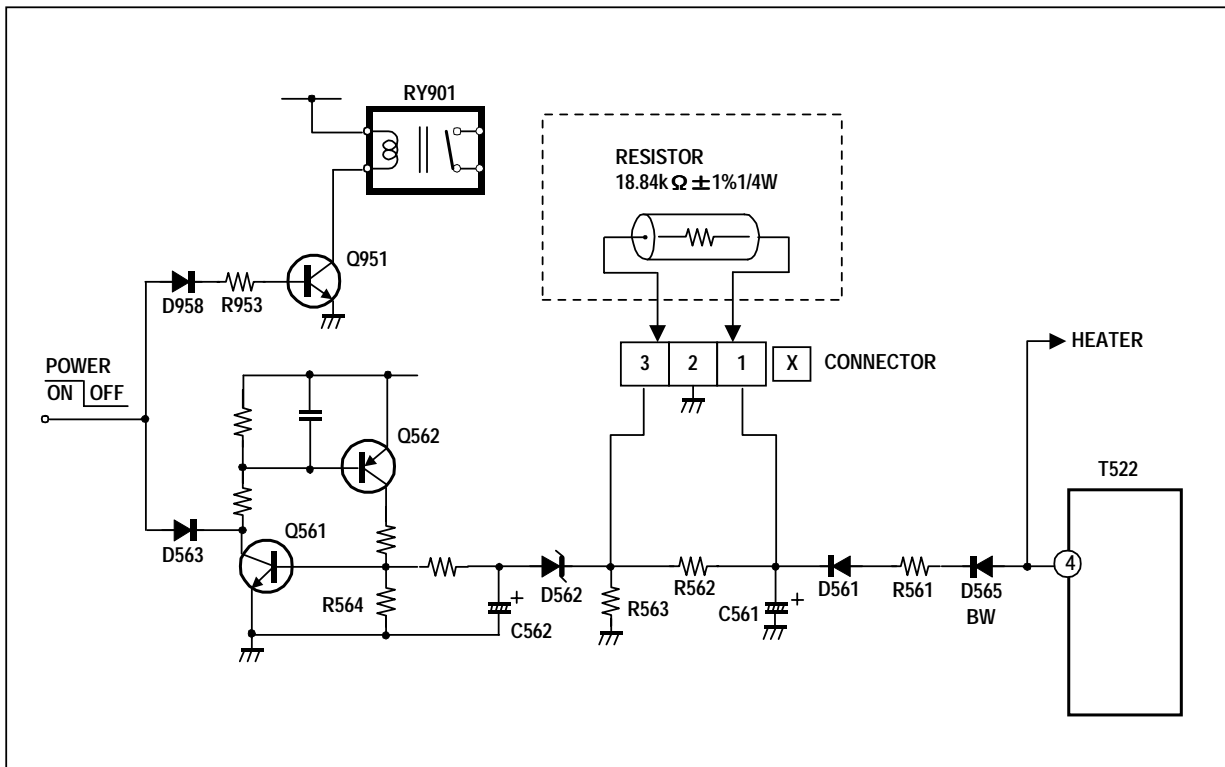

Fig. 1

SELF CHECK FUNCTIONS

1. Outline

This model has self check functions given below. When a malfunction has been detected, the POWER is turned off and the LED flashes to inform of the failure. The malfunction is detected by the signal input state of the control line connected to the microcomputer.

2. Self check items

Check item	Details of detection	Method of detection	State of malfunction
CRT NECK protector (Also detected if the power supply line output from the HVT (High voltage Transformer) has shorted with the ground.)	When the vertical circuit S-correction capacitor C427 is shorted, detect the potential drop of the C427, and prevent the burn damage to the CRT NECK. (Grounding of shorting of the power supply output from the HVT to the vertical circuit, and the small signal power supply is also detected.)	The microcomputer detects at 1 second intervals. If NG is detected for more than 1 ms, a malfunction is interpreted.	When a malfunction has been detected, the POWER is turned off. While the POWER is being turned off, the power key of the remote controller is not operational until the power code is taken out and put in again.

3. Self check indicating function

The self-check function begins detection about 5 seconds after power is supplied.

In the event a malfunction is detected, the power is cut off immediately.

At this time, the ON-TIMER LED flashes to inform of the malfunction.

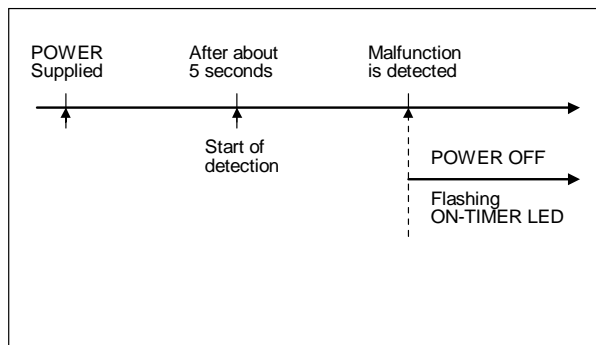

[ON-TIMER LED indication]

The ON-TIMER LED flashes at 0.5 seconds intervals.

REPLACEMENT OF CHIP COMPONENT

■ CAUTIONS

1. Avoid heating for more than 3 seconds.
2. Do not rub the electrodes and the resist parts of the pattern.
3. When removing a chip part, melt the solder adequately.
4. Do not reuse a chip part after removing it.

■ SOLDERING IRON

1. Use a high insulation soldering iron with a thin pointed end of it.
2. A 30w soldering iron is recommended for easily removing parts.

■ REPLACEMENT STEPS

1. How to remove Chip parts

◆ Resistors, capacitors, etc.

- (1) As shown in the figure, push the part with tweezers and alternately melt the solder at each end.

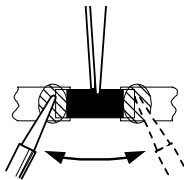

- (2) Shift with tweezers and remove the chip part.

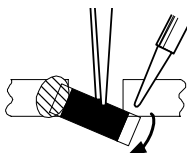

◆ Transistors, diodes, variable resistors, etc.

- (1) Apply extra solder to each lead.

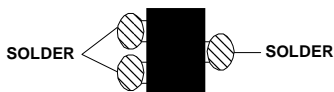

- (2) As shown in the figure, push the part with tweezers and alternately melt the solder at each lead. Shift and remove the chip part.

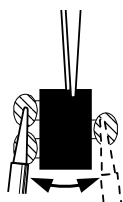

Note : After removing the part, remove remaining solder from the pattern.

2. How to install Chip parts

◆ Resistors, capacitors, etc.

- (1) Apply solder to the pattern as indicated in the figure.

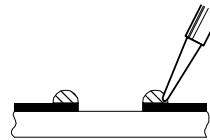

- (2) Grasp the chip part with tweezers and place it on the solder. Then heat and melt the solder at both ends of the chip part.

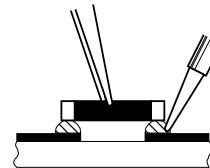

◆ Transistors, diodes, variable resistors, etc.

- (1) Apply solder to the pattern as indicated in the figure.
- (2) Grasp the chip part with tweezers and place it on the solder.
- (3) First solder lead **A** as indicated in the figure.

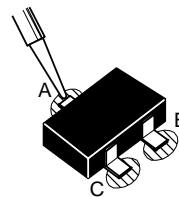

- (4) Then solder leads **B** and **C**.

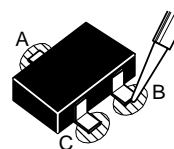



JVC

VICTOR COMPANY OF JAPAN, LIMITED
HOME AV NETWORK BUSINESS UNIT 12, 3-chome, Moriya-cho, Kanagawa-ku, Yokohama, Kanagawa-prefecture, 221-8528, Japan

N29220R-MEM #999
N29220S-MEM #3



Printed in Japan
VP 0109
DP3051

Other ManualsLib Projects



www.manualslib.com



www.manualslib.de



www.manualslib.es



www.manualslib.fr



www.manualslib.nl



www.manualslib.mx



www.manualslib.tech 30+ Languages