

# JVC

## SERVICE MANUAL

### COLOR TELEVISION

BASIC CHASSIS

AC

# AV-36230 /H    AV-36260 /H AV-36230 /R    AV-36260 /R

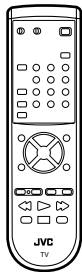

RM-C306  
[AV-36230]

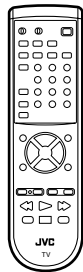

RM-C305  
[AV-36260]

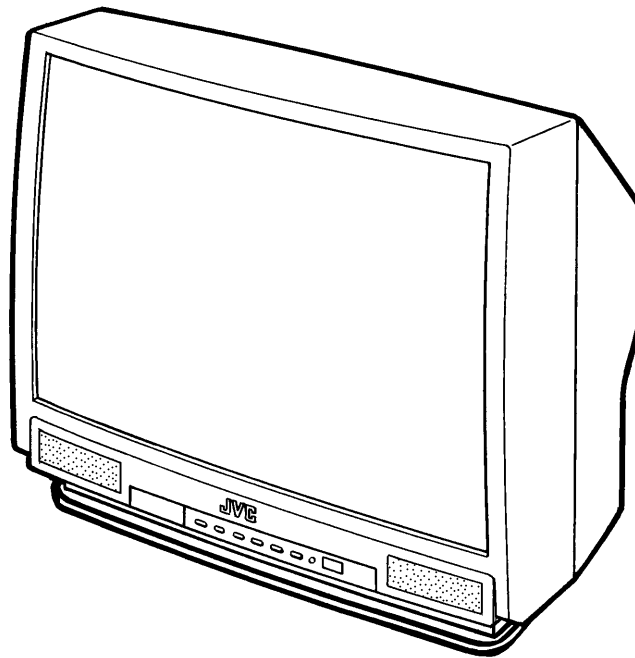

## CONTENTS

- SPECIFICATIONS .....2
- SAFETY PRECAUTIONS .....3
- FEATURES .....5
- MAIN DIFFERENCE LIST .....6
- HOW TO IDENTIFY MODELS .....6
- FUNCTIONS .....7
- SPECIFIC SERVICE INSTRUCTIONS .....8
- SERVICE ADJUSTMENTS .....13
- ★ STANDARD CIRCUIT DIAGRAM (APPENDIX) ..... 2-1
- PARTS LIST .....35

# SPECIFICATIONS

| Items  | Contents   |
|--|--|
| <b>Dimensions (W × H × D)</b>                | 30-1/4" × 26-1/4" × 21-1/2" / 76.8cm × 66.7cm × 54.7cm   |
| <b>Mass</b>                                  | 112.2 lbs / 51.0 kg  |
| <b>TV RF System</b>                          | CCIR(M)  |
| <b>Color Sound System</b>                    | NTSC, BTSC System (Multi Channel Sound)  |
| <b>TV Receiving Channels and Frequency</b>   |  |
| <b>VL Band</b>                               | (02~06) 54MHz~88MHz  |
| <b>VH Band</b>                               | (07~13) 174MHz~216MHz  |
| <b>UHF Band</b>                              | (14~69) 470MHz~806MHz  |
| <b>CATV Receiving Channels and Frequency</b> |  |
| <b>Low Band</b>                              | (02~06, A-8) by (02~06&01)   |
| <b>High Band</b>                             | (07~13) by (07~13)   |
| <b>Mid Band</b>                              | (A~1) by (14~22)   |
| <b>Super Band</b>                            | (J~W) by (23~36)   |
| <b>Hyper Band</b>                            | (W+1~W+28) by (37~64)  |
| <b>Ultra Band</b>                            | (W+29~W+84) by (65~125)  |
| <b>Sub Mid Band</b>                          | (A8, A4~A1) by (01, 96~99)   |
| <b>TV/CATV Total Channel</b>                 | 180 Channels   |
| <b>Intermediate Frequency</b>                |  |
| <b>Video IF Carrier</b>                      | 45.75MHz   |
| <b>Sound IF Carrier</b>                      | 41.25MHz (4.5MHz)  |
| <b>Color Sub Carrier</b>                     | 3.58MHz  |
| <b>Power Input</b>                           | 120V AC, 60Hz  |
| <b>Power Consumption</b>                     | 133W [AV-32260], 128W [AV-32230]   |
| <b>Picture Tube</b>                          | 32" (80cm) Measured Diagonally   |
| <b>High Voltage</b>                          | 31kV±1.3kV (at zero beam current)  |
| <b>Speaker</b>                               | 2" × 4-3/4" / 5 × 12cm Oval type × 2   |
| <b>Audio Power Output</b>                    | 3W × 2   |
| <b>Video / Audio Input (1 / 2 / 3)</b>       | Video(1,2,3) : 1Vp-p, 75Ω (RCA pin jack)<br>Audio(1,2,3) : 500mVrms (-4dBs), High Impedance (RCA pin jack)<br>S-Video ( Input 1 Over )<br>Y : 1Vp-p Positive (negative sync provided, when terminated with 75Ω)<br>C : 0.286Vp-p (burst signal, when terminated with 75Ω)<br>Component Input ( Input 2 )<br>Y : 1Vp-p positive (negative sync provided, when terminated with 75Ω)<br>P <sub>B</sub> /P <sub>R</sub> : 0.7Vp-p 75 Ω |
| <b>Audio Output (Variable)</b>               | Variable : More then 0~1550mVrms (+6dBs)<br>Low impedance (400Hz when modulated 100%) (RCA pin jack)   |
| <b>AV Compu link EX Input</b>                | 3.5mm mini jack  |
| <b>Antenna terminal</b>                      | 75Ω(VHF/UHF) Terminal, F-Type Connector  |
| <b>Remote Control Unit</b>                   | RM-C305-1A [AV-32260], RM-C306-1A [AV-32230]<br>(AA/R6/UM-3 battery × 2)   |

Design & specifications are subject to change without notice.

# SAFETY PRECAUTIONS

- The design of this product contains special hardware, many circuits and components specially for safety purposes. For continued protection, no changes should be made to the original design unless authorized in writing by the manufacturer. Replacement parts must be identical to those used in the original circuits. Service should be performed by qualified personnel only.
- Alterations of the design or circuitry of the products should not be made. Any design alterations or additions will void the manufacturer's warranty and will further relieve the manufacturer of responsibility for personal injury or property damage resulting therefrom.
- Many electrical and mechanical parts in the products have special safety-related characteristics. These characteristics are often not evident from visual inspection nor can the protection afforded by them necessarily be obtained by using replacement components rated for higher voltage, wattage, etc. Replacement parts which have these special safety characteristics are identified in the parts list of Service manual. **Electrical components having such features are identified by shading on the schematics and by ( ⚠ ) on the parts list in Service manual.** The use of a substitute replacement which does not have the same safety characteristics as the recommended replacement part shown in the parts list of Service manual may cause shock, fire, or other hazards.
- Use isolation transformer when hot chassis.**  
The chassis and any sub-chassis contained in some products are connected to one side of the AC power line. An isolation transformer of adequate capacity should be inserted between the product and the AC power supply point while performing any service on some products when the HOT chassis is exposed.
- Don't short between the LIVE side ground and ISOLATED (NEUTRAL) side ground or EARTH side ground when repairing.**  
Some model's power circuit is partly different in the GND. The difference of the GND is shown by the LIVE : ( ⊥ ) side GND, the ISOLATED(NEUTRAL) : ( ⚡ ) side GND and EARTH : ( ⊕ ) side GND. Don't short between the LIVE side GND and ISOLATED(NEUTRAL) side GND or EARTH side GND and never measure with a measuring apparatus (oscilloscope etc.) the LIVE side GND and ISOLATED(NEUTRAL) side GND or EARTH side GND at the same time.  
If above note will not be kept, a fuse or any parts will be broken.
- If any repair has been made to the chassis, it is recommended that the B1 setting should be checked or adjusted (See ADJUSTMENT OF B1 POWER SUPPLY).
- The high voltage applied to the picture tube must conform with that specified in Service manual. Excessive high voltage can cause an increase in X-Ray emission, arcing and possible component damage, therefore operation under excessive high voltage conditions should be kept to a minimum, or should be prevented. If severe arcing occurs, remove the AC power immediately and determine the cause by visual inspection (incorrect installation, cracked or melted high voltage harness, poor soldering, etc.). To maintain the proper minimum level of soft X-Ray emission, components in the high voltage circuitry including the picture tube must be the exact replacements or alternatives approved by the manufacturer of the complete product.
- Do not check high voltage by drawing an arc. Use a high voltage meter or a high voltage probe with a VTVM. Discharge the picture tube before attempting meter connection, by connecting a clip lead to the ground frame and connecting the other end of the lead through a 10kΩ 2W resistor to the anode button.
- When service is required, observe the original lead dress. Extra precaution should be given to assure correct lead dress in the high voltage circuit area. Where a short circuit has occurred, those components that indicate evidence of overheating should be replaced. Always use the manufacturer's replacement components.

## 10. Isolation Check

### (Safety for Electrical Shock Hazard)

After re-assembling the product, always perform an isolation check on the exposed metal parts of the cabinet (antenna terminals, video/audio input and output terminals, Control knobs, metal cabinet, screwheads, earphone jack, control shafts, etc.) to be sure the product is safe to operate without danger of electrical shock.

#### (1) Dielectric Strength Test

The isolation between the AC primary circuit and all metal parts exposed to the user, particularly any exposed metal part having a return path to the chassis should withstand a voltage of 1100V AC (r.m.s.) for a period of one second.

(... Withstand a voltage of 1100V AC (r.m.s.) to an appliance rated up to 120V, and 3000V AC (r.m.s.) to an appliance rated 200V or more, for a period of one second.)

This method of test requires a test equipment not generally found in the service trade.

#### (2) Leakage Current Check

Plug the AC line cord directly into the AC outlet (do not use a line isolation transformer during this check.). Using a "Leakage Current Tester", measure the leakage current from each exposed metal part of the cabinet, particularly any exposed metal part having a return path to the chassis, to a known good earth ground (water pipe, etc.). Any leakage current must not exceed 0.5mA AC (r.m.s.).

However, in tropical area, this must not exceed 0.2mA AC (r.m.s.).

#### ● Alternate Check Method

Plug the AC line cord directly into the AC outlet (do not use a line isolation transformer during this check.). Use an AC voltmeter having 1000 ohms per volt or more sensitivity in the following manner. Connect a 1500Ω 10W resistor paralleled by a 0.15μF AC-type capacitor between an exposed metal part and a known good earth ground (water pipe, etc.). Measure the AC voltage across the resistor with the AC voltmeter. Move the resistor connection to each exposed metal part, particularly any exposed metal part having a return path to the chassis, and measure the AC voltage across the resistor. Now, reverse the plug in the AC outlet and repeat each measurement. Any voltage measured must not exceed 0.75V AC (r.m.s.). This corresponds to 0.5mA AC (r.m.s.).

However, in tropical area, this must not exceed 0.3V AC (r.m.s.). This corresponds to 0.2mA AC (r.m.s.).

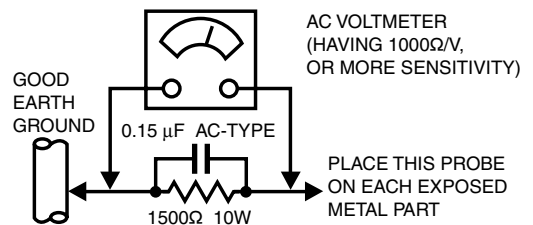

## 11. High voltage hold down circuit check.

After repair of the high voltage hold down circuit, this circuit shall be checked to operate correctly.

See item "How to check the high voltage hold down circuit".

This mark shows a fast operating fuse, the letters indicated below show the rating.



**POWER CORD REPLACEMENT WARNING**  
Connecting the white line side of power cord to "WHT" character side.

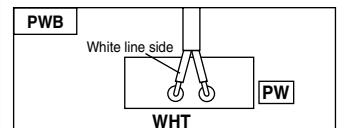

# REPLACEMENT OF CHIP COMPONENT

## ■ CAUTIONS

1. Avoid heating for more than 3 seconds.
2. Do not rub the electrodes and the resist parts of the pattern.
3. When removing a chip part, melt the solder adequately.
4. Do not reuse a chip part after removing it.

## ■ SOLDERING IRON

1. Use a high insulation soldering iron with a thin pointed end of it.
2. A 30w soldering iron is recommended for easily removing parts.

## ■ REPLACEMENT STEPS

### 1. How to remove Chip parts

#### ◆ Resistors, capacitors, etc.

- (1) As shown in the figure, push the part with tweezers and alternately melt the solder at each end.

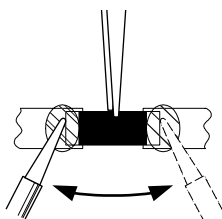

- (2) Shift with tweezers and remove the chip part.

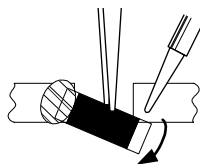

#### ◆ Transistors, diodes, variable resistors, etc.

- (1) Apply extra solder to each lead.

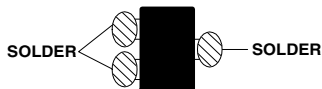

- (2) As shown in the figure, push the part with tweezers and alternately melt the solder at each lead. Shift and remove the chip part.

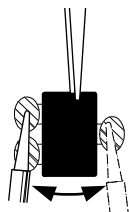

*Note : After removing the part, remove remaining solder from the pattern.*

### 2. How to install Chip parts

#### ◆ Resistors, capacitors, etc.

- (1) Apply solder to the pattern as indicated in the figure.

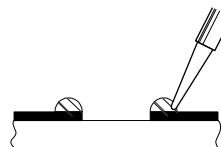

- (2) Grasp the chip part with tweezers and place it on the solder. Then heat and melt the solder at both ends of the chip part.

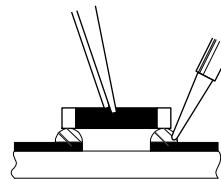

#### ◆ Transistors, diodes, variable resistors, etc.

- (1) Apply solder to the pattern as indicated in the figure.
- (2) Grasp the chip part with tweezers and place it on the solder.
- (3) First solder lead **A** as indicated in the figure.

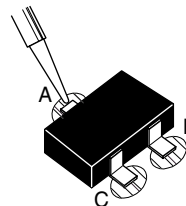

- (4) Then solder leads **B** and **C**.

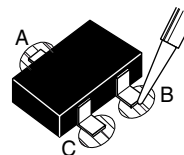

# FEATURES

- Full-square CRT (cathode ray tube) reproduces fine textured picture in every detail.
- I<sup>2</sup>C bus control utilizes single chip ICs.
- Built in Twin Tuner system. [Only for AV-32260 model]
- Built-in HYPER-SURROUND system.
- Adoption of the Picture-In-Picture (PIP) function. [Only for AV-32260 model]
- 3 LINE DIGITAL COMB FILTER circuit improved picture quality.
- Component input terminal for talking best advantage of Component Video Signal.
- Audio Video input terminal. (S-input ×1, V-input ×2)
- Variable audio output terminal.
- Closed-caption broadcasts can be viewed.
- With AV COMPU LINK EX terminal.

## ■ SYSTEM BLOCK DIAGRAM

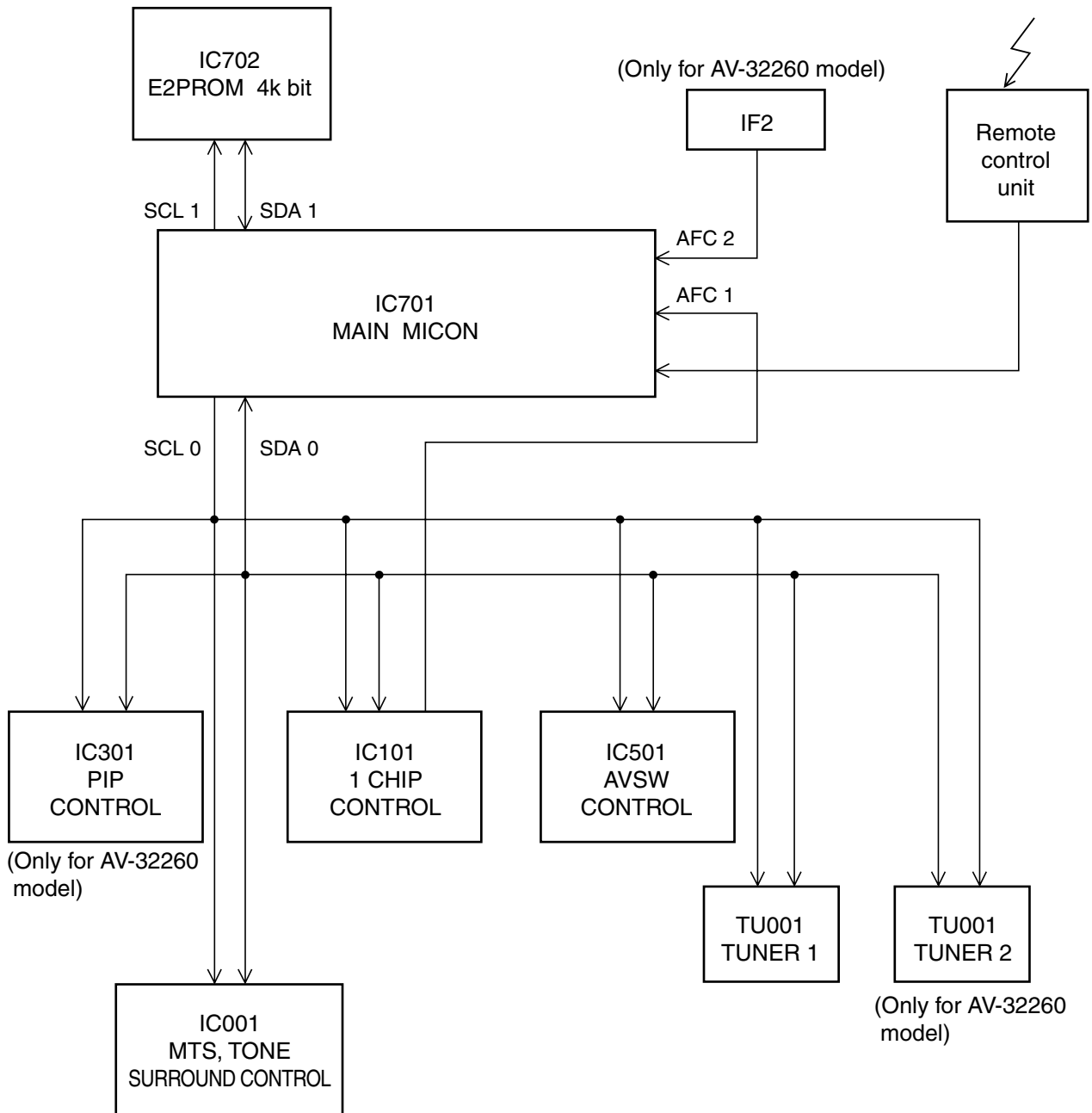

# MAIN DIFFERENCE LIST

[AV-32230/G & AV-32230/H & AV-32230/M]

| △ | Model<br>Part name | AV-32230/G    | AV-32230/H    | AV-32230/M   |
|---|--------------------|---------------|---------------|--------------|
|   | MAIN PWB           | SAC-1535A-M2  | SAC-1536A-M2  | SAC-1537A-M2 |
|   | CRT SOCKET PWB     | SAC-3508A-M2  | SAC-3509A-M2  | SAC-3510A-M2 |
| △ | PICTRE TUBE        | A80QCF240X14L | A80LJF30X08-G | M80JUA061X06 |
| △ | DEG. COIL          | QQW0086-001   | CELD066-002JA | ←            |

[AV-32260/G & AV-32260/H & AV-32260/M]

| △ | Model<br>Part name | AV-32260/G    | AV-32260/H    | AV-32260/M   |
|---|--------------------|---------------|---------------|--------------|
|   | MAIN PWB           | SAC-1529A-M2  | SAC-1530A-M2  | SAC-1531A-M2 |
|   | CRT SOCKET PWB     | SAC-3508A-M2  | SAC-3509A-M2  | SAC-3510A-M2 |
| △ | PICTURE TUBE       | A80QCF240X14L | A80LJF30X08-G | M80JUA061X06 |
| △ | DEG. COIL          | QQW0086-001   | CELD066-002JA | ←            |

# HOW TO IDENTIFY MODELS

- The difference between AV-32230/G, AV-32230/H and AV-32230/M is in the PICTURE TUBE. As the result of the difference in PICTURE TUBE, the MAIN PWB also differ.

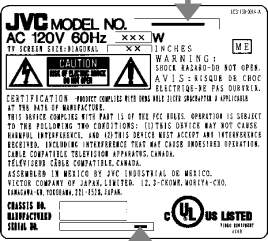
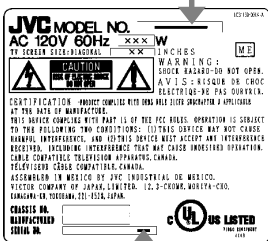
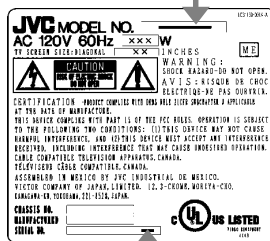
| △ | Model<br>Part name | AV-32230/G   | AV-32230/H  | AV-32230/M   |
|---|--------------------|--|---|--|
| △ | RATING LABEL       | LC31139-001A-A   | ←   | ←  |
|   |                    | <p>INDICATED AV-32230</p>  <p>INDICATED "G"</p> | <p>INDICATED AV-32230</p>  <p>INDICATED "H"</p> | <p>INDICATED AV-32230</p>  <p>INDICATED "M"</p> |

- The difference between AV-32260/G, AV-32260/H and AV-32260/M is in the PICTURE TUBE.  
As the result of the difference in PICTURE TUBE, the MAIN PWB also differ.

| Part name    | Model | AV-32260/G                                     | AV-32260/H                                     | AV-32260/M                                     |
|--------------|-------|--|--|--|
| RATING LABEL |       | LC31139-001A-A                                 | ←  | ←  |
|              |       | <p>INDICATED AV-32260</p> <p>INDICATED "G"</p> | <p>INDICATED AV-32260</p> <p>INDICATED "H"</p> | <p>INDICATED AV-32260</p> <p>INDICATED "M"</p> |

# FUNCTIONS

## FRONT PANEL

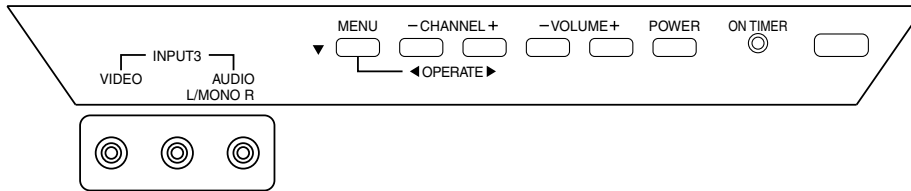

## REMOTE CONTROL UNIT (RM-C305-1A) [AV-32260]

## (RM-C306-1A) [AV-32230]

## REAR PANEL

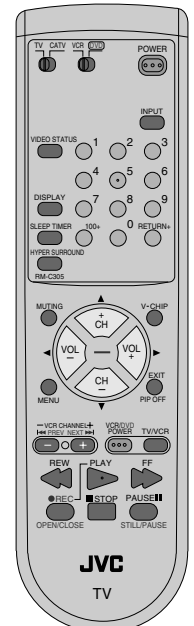
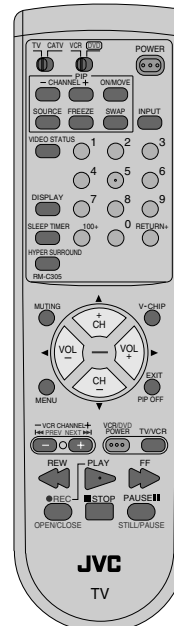
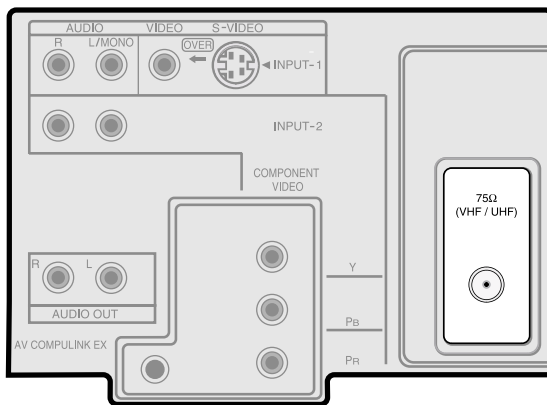

# SPECIFIC SERVICE INSTRUCTIONS

## DISASSEMBLY PROCEDURE

### REMOVING THE REAR COVER

1. Unplug the power supply cord.
2. Remove the 11 screws marked (A) as shown in Fig.1.
3. Withdraw the REAR COVER toward you.

#### [CAUTION]

- When reinstalling the rear cover, carefully push it inward after inserting the MAIN PWB into the rear cover groove.

### REMOVING THE CHASSIS

- After removing the rear cover.
1. Slightly raise the both sides of the chassis by hand and remove the 3 claws marked (B) under the chassis from the front cabinet as shown in Fig.1.
  2. Withdraw the chassis backward along the rail in the arrow direction marked (C) as shown in Fig.1.

(If necessary, take off the wire clamp, connector's etc.)

\* When conducting a check with power supplied, be sure to confirm that the CRT earth wire is connected to the CRT SOCKET PWB and the MAIN PWB.

### REMOVING THE TERMINAL BOARD

- After removing the rear cover.
1. Remove the 4 screws marked (D) as shown in Fig.1.
  2. When you pull out the TERMINAL BOARD in the direction of arrow marked (E) as shown in Fig.1, it can be removed.

### REMOVING THE FRONT CONTROL AND FRONT AV INPUT PW BOARDS

- After removing the rear cover and chassis.
1. Remove the 2 screws marked (F) and the 2 screws marked (G) as shown in Fig.1.
  2. Then remove the FRONT CONTROL PWB and FRONT AV INPUT PWB.

(If necessary, take off the wire, connector's etc.)

### REMOVING THE LF PW BOARD

- After removing the rear cover and chassis.
1. Lift the left side of the LF PWB while pressing the 2 PWB stoppers marked (H) in the arrow direction marked (I) as shown in Fig.1.
  2. Then remove the LF PWB.

(If necessary, take off the wire, connector's etc.)

### REMOVING THE SPEAKER

- After removing the rear cover.
1. Remove the 2 screws marked (K) as shown in Fig.1.
  2. Withdraw the speaker backward.
  3. Follow the same steps when removing the other hand speaker.

### CHECKING THE MAIN PW BOARD

1. To check the back side of the MAIN PW Board.
  - 1) Pull out the chassis. (Refer to REMOVING THE CHASSIS).
  - 2) Erect the chassis vertically so that you can easily check the back side of the MAIN PW Board.

#### [CAUTION]

- When erecting the chassis, be careful so that there will be no contacting with other PW Board.
- Before turning on power, make sure that the CRT earth wire and other connectors are properly connected.

### WIRE CLAMPING AND CABLE TYING

1. Be sure clamp the wire.
2. Never remove the cable tie used for tying the wires together. Should it be inadvertently removed, be sure to tie the wires with a new cable tie.

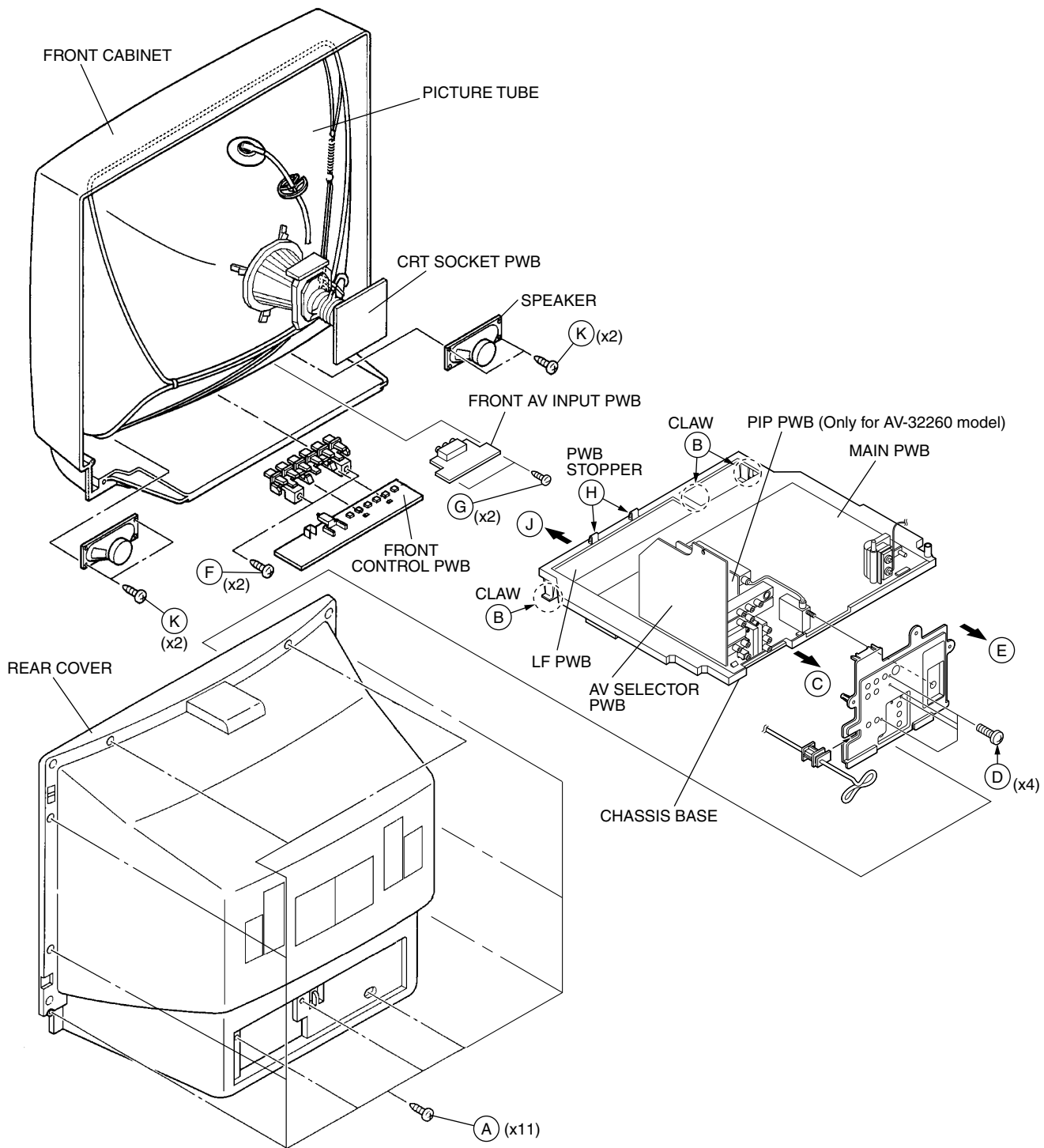

Fig.1

## REMOVING THE CRT

\* Replacement of the CRT should be performed by 2 or more persons.

- After removing the rear cover, chassis etc.,
- 1. Putting the CRT change table on soft cloth, the CRT change table should also be covered with such soft cloth (shown in Fig.2).
- 2. While keeping the surface of CRT down, mount the TV set on the CRT change table balanced will as shown in Fig.3.
- 3. Remove 4 screws marked by arrows with a box type screwdriver as shown in Fig.3.
- Since the cabinet will drop when screws have been removed, be sure to support the cabinet with hands.
- 4. After 4 screws have been removed, put the cabinet slowly on cloth (At this time, be carefully so as not to damage the front surface of the cabinet) shown in Fig.4.
- The CRT should be assembled according to the opposite sequence of its dismantling steps.

\* The CRT change table should preferably be smaller than the CRT surface, and its height be about 35cm.

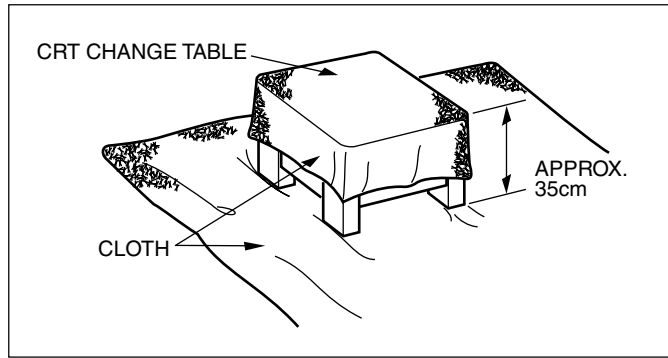

Fig. 2

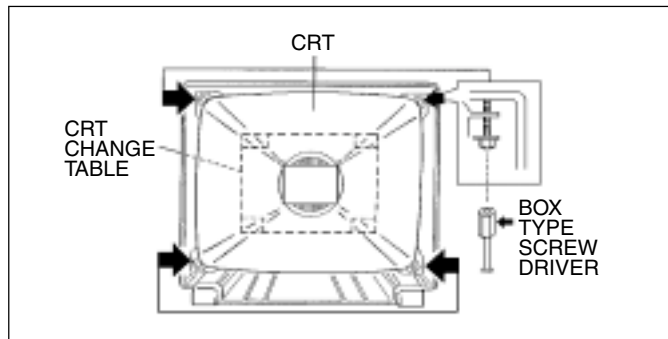

Fig. 3

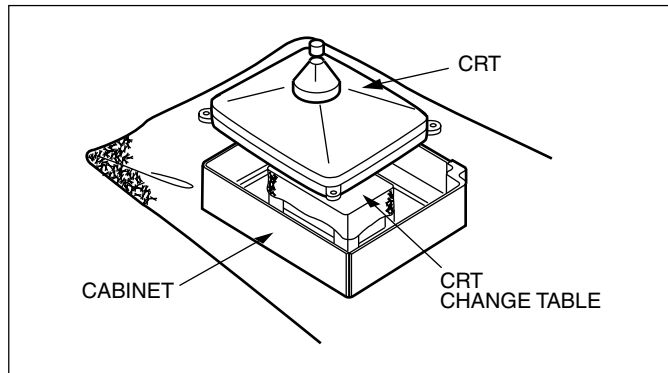

Fig. 4

## COATING OF SILICON GREASE FOR ELECTRICAL INSULATION ON THE CRT ANODE CAP SECTION.

- Subsequent to replacement of the CRT and HV transformer or repair of the anode cap, etc. by dismantling them, be sure to coat silicon grease for electrical insulation as shown in Fig.5.
- Wipe around the anode button with clean and dry cloth. (Fig.5)  
Coat silicon grease on the section around the anode button. At this time, take care so that any silicon greases dose not sticks to the anode button. (Fig.6)

★ Silicon grease product No. KS - 650N

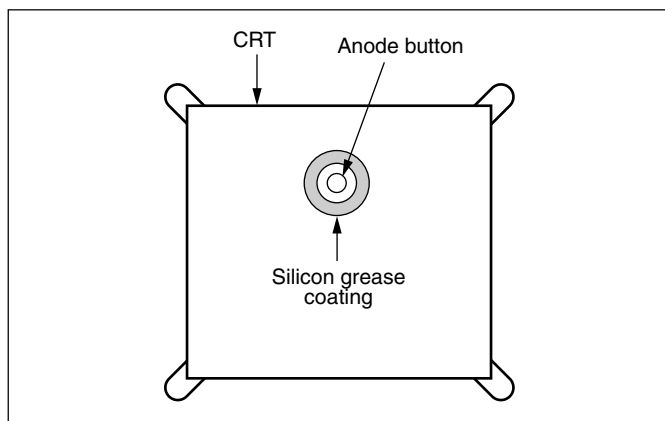

Fig. 5

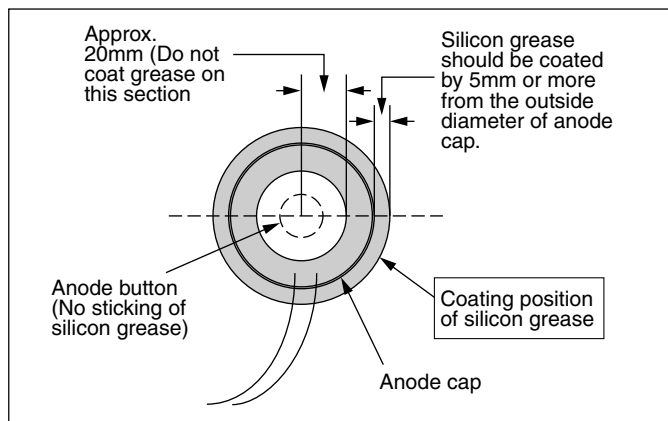

Fig. 6

# MEMORY IC REPLACEMENT

## 1. Memory IC

This model use a memory IC.

This memory IC stores data for proper operation of the video and deflection circuits.

When replacing, be sure to use an IC containing this (initial value) data.

## 2. Memory IC replacement procedure

| Procedure  | Screen display  |         |            |         |        |           |            |        |              |            |       |          |       |         |        |     |  |           |            |         |         |         |              |
|--|---|---------|------------|---------|--------|-----------|------------|--------|--------------|------------|-------|----------|-------|---------|--------|-----|--|-----------|------------|---------|---------|---------|--------------|
| <p><b>(1) Power off</b><br/>Switch off the power and disconnect the power cord from the outlet.</p>  |   |         |            |         |        |           |            |        |              |            |       |          |       |         |        |     |  |           |            |         |         |         |              |
| <p><b>(2) Replace the memory IC</b><br/>Initial value must be entered into the new IC.</p>   |   |         |            |         |        |           |            |        |              |            |       |          |       |         |        |     |  |           |            |         |         |         |              |
| <p><b>(3) Power on</b><br/>Connect the power cord to the outlet and switch on the power.</p>   |   |         |            |         |        |           |            |        |              |            |       |          |       |         |        |     |  |           |            |         |         |         |              |
| <p><b>(4) System constant check and setting</b></p> <ol style="list-style-type: none"> <li>1) Press <b>SLEEP TIMER</b> key and, while the indication of "SLEEP TIMER 0 MIN." is being displayed, press <b>DISPLAY</b> key and <b>VIDEO STATUS</b> key on the remote control unit simultaneously.</li> <li>2) The SERVICE MENU screen of Fig.1 is displayed.</li> <li>3) While the SERVICE MENU is displayed, again simultaneously press the DISPLAY and VIDEO STATUS keys to display the Fig.2 SYSTEM CONSTANT screen.</li> <li>4) Refer to the SYSTEM CONSTANT table and check the setting items. Where these differ, select the setting item with the MENU UP/DOWN key and adjust the setting with the MENU LEFT/RIGHT keys. (The letters of the selected item are displayed in yellow.)</li> <li>5) After adjusting, release the MENU LEFT/RIGHT key to store the setting value.</li> <li>6) Press the EXIT key twice to return the normal screen.</li> </ol> | <div data-bbox="1036 814 1453 1123" style="border: 1px solid black; padding: 5px;"> <p style="text-align: center;"><b>SERVICE MENU</b></p> <table style="width: 100%; border-collapse: collapse;"> <tr> <td style="width: 50%; border-bottom: 1px solid black;">PICTURE</td> <td style="width: 50%; border-bottom: 1px solid black;">SOUND</td> </tr> <tr> <td style="border-bottom: 1px solid black;">THEATER</td> <td style="border-bottom: 1px solid black;">OTHERS</td> </tr> <tr> <td style="border-bottom: 1px solid black;">LOW LIGHT</td> <td style="border-bottom: 1px solid black;">HIGH LIGHT</td> </tr> <tr> <td style="border-bottom: 1px solid black;">RF AFC</td> <td style="border-bottom: 1px solid black;">I2C BUS CTRL</td> </tr> <tr> <td style="border-bottom: 1px solid black;">VCO(CW)</td> <td></td> </tr> </table> <p>SELECT BY ▲ ▼<br/>OPERATE BY ◀ ▶ EXIT BY (EXIT)</p> </div> <p style="text-align: center;">[AV-32230]</p> <div data-bbox="1036 1180 1453 1488" style="border: 1px solid black; padding: 5px;"> <p style="text-align: center;"><b>SERVICE MENU</b></p> <table style="width: 100%; border-collapse: collapse;"> <tr> <td style="width: 50%; border-bottom: 1px solid black;">PICTURE</td> <td style="width: 50%; border-bottom: 1px solid black;">SOUND</td> </tr> <tr> <td style="border-bottom: 1px solid black;">THEATER</td> <td style="border-bottom: 1px solid black;">OTHERS</td> </tr> <tr> <td style="border-bottom: 1px solid black;">PIP</td> <td></td> </tr> <tr> <td style="border-bottom: 1px solid black;">LOW LIGHT</td> <td style="border-bottom: 1px solid black;">HIGH LIGHT</td> </tr> <tr> <td style="border-bottom: 1px solid black;">RF AFC1</td> <td style="border-bottom: 1px solid black;">RF AFC2</td> </tr> <tr> <td style="border-bottom: 1px solid black;">VCO(CW)</td> <td style="border-bottom: 1px solid black;">I2C BUS CTRL</td> </tr> </table> <p>SELECT BY ▲ ▼<br/>OPERATE BY ◀ ▶ EXIT BY (EXIT)</p> </div> <p style="text-align: center;">[AV-32260]</p> <p style="text-align: center;">Fig.1</p> | PICTURE | SOUND      | THEATER | OTHERS | LOW LIGHT | HIGH LIGHT | RF AFC | I2C BUS CTRL | VCO(CW)    |       | PICTURE  | SOUND | THEATER | OTHERS | PIP |  | LOW LIGHT | HIGH LIGHT | RF AFC1 | RF AFC2 | VCO(CW) | I2C BUS CTRL |
| PICTURE  | SOUND   |         |            |         |        |           |            |        |              |            |       |          |       |         |        |     |  |           |            |         |         |         |              |
| THEATER  | OTHERS  |         |            |         |        |           |            |        |              |            |       |          |       |         |        |     |  |           |            |         |         |         |              |
| LOW LIGHT  | HIGH LIGHT  |         |            |         |        |           |            |        |              |            |       |          |       |         |        |     |  |           |            |         |         |         |              |
| RF AFC   | I2C BUS CTRL  |         |            |         |        |           |            |        |              |            |       |          |       |         |        |     |  |           |            |         |         |         |              |
| VCO(CW)  |   |         |            |         |        |           |            |        |              |            |       |          |       |         |        |     |  |           |            |         |         |         |              |
| PICTURE  | SOUND   |         |            |         |        |           |            |        |              |            |       |          |       |         |        |     |  |           |            |         |         |         |              |
| THEATER  | OTHERS  |         |            |         |        |           |            |        |              |            |       |          |       |         |        |     |  |           |            |         |         |         |              |
| PIP  |   |         |            |         |        |           |            |        |              |            |       |          |       |         |        |     |  |           |            |         |         |         |              |
| LOW LIGHT  | HIGH LIGHT  |         |            |         |        |           |            |        |              |            |       |          |       |         |        |     |  |           |            |         |         |         |              |
| RF AFC1  | RF AFC2   |         |            |         |        |           |            |        |              |            |       |          |       |         |        |     |  |           |            |         |         |         |              |
| VCO(CW)  | I2C BUS CTRL  |         |            |         |        |           |            |        |              |            |       |          |       |         |        |     |  |           |            |         |         |         |              |
| <p><b>(5) Receive channel setting</b><br/>Refer to the OPERATING INSTRUCTIONS(USER'S GUIDE) and set the receive channels (Channels Preset) as described.</p>   |   |         |            |         |        |           |            |        |              |            |       |          |       |         |        |     |  |           |            |         |         |         |              |
| <p><b>(6) User settings</b><br/>Check the user setting items according to Table 2.<br/>Where these do not agree, refer to the OPERATING INSTRUCTIONS (USER'S GUIDE) and set the items as described.</p>  |   |         |            |         |        |           |            |        |              |            |       |          |       |         |        |     |  |           |            |         |         |         |              |
| <p><b>(7) SERVICE MENU setting</b><br/>Verify what to set in the SERVICE MENU, and set whatever is necessary.(Fig.1) Refer to the SERVICE ADJUSTMENT for setting.</p>  | <div data-bbox="1036 1587 1453 1896" style="border: 1px solid black; padding: 5px;"> <p style="text-align: center;"><b>SYSTEM CONSTANT</b></p> <table style="width: 100%; border-collapse: collapse;"> <tr> <td style="width: 50%;">MODEL</td> <td style="width: 50%;">: ***-****</td> </tr> <tr> <td>PURITY</td> <td>: NO</td> </tr> <tr> <td>CCD</td> <td>: YES</td> </tr> <tr> <td>V-CHIP</td> <td>: YES</td> </tr> <tr> <td>CAN V-CHIP</td> <td>: YES</td> </tr> <tr> <td colspan="2">***** **</td> </tr> </table> <p>SELECT BY ▲ ▼<br/>OPERATE BY ◀ ▶ EXIT BY (EXIT)</p> </div> <p style="text-align: center;">Fig.2</p>   | MODEL   | : ***-**** | PURITY  | : NO   | CCD       | : YES      | V-CHIP | : YES        | CAN V-CHIP | : YES | ***** ** |       |         |        |     |  |           |            |         |         |         |              |
| MODEL  | : ***-****  |         |            |         |        |           |            |        |              |            |       |          |       |         |        |     |  |           |            |         |         |         |              |
| PURITY   | : NO  |         |            |         |        |           |            |        |              |            |       |          |       |         |        |     |  |           |            |         |         |         |              |
| CCD  | : YES   |         |            |         |        |           |            |        |              |            |       |          |       |         |        |     |  |           |            |         |         |         |              |
| V-CHIP   | : YES   |         |            |         |        |           |            |        |              |            |       |          |       |         |        |     |  |           |            |         |         |         |              |
| CAN V-CHIP   | : YES   |         |            |         |        |           |            |        |              |            |       |          |       |         |        |     |  |           |            |         |         |         |              |
| ***** **   |   |         |            |         |        |           |            |        |              |            |       |          |       |         |        |     |  |           |            |         |         |         |              |

**TABLE 1 (System Constant setting)**

| Setting item | Setting content  | Setting value |          |
|--------------|--|---------------|----------|
|              |  | AV-32230      | AV-32260 |
| MODEL        |  | AV-32230      | AV-32260 |
| PURITY       | <input type="checkbox"/> → YES → NO <input type="checkbox"/> | NO            |          |
| CCD          | <input type="checkbox"/> → YES → NO <input type="checkbox"/> | YES           |          |
| V-CHIP       | <input type="checkbox"/> → YES → NO <input type="checkbox"/> | YES           |          |
| CAN V-CHIP   | <input type="checkbox"/> → YES → NO <input type="checkbox"/> | YES           |          |

**TABLE 2 (User setting value)**

| Setting item                         | Setting value                            |
|--------------------------------------|--|
| <b>1. Use remote controller keys</b> |  |
| POWER                                | OFF                                      |
| CHANNEL                              | CH-02                                    |
| VOLUME                               | 5  |
| INPUT                                | TV                                       |
| HYPER SURROUND                       | OFF                                      |
| DISPLAY                              | OFF                                      |
| SLEEP TIMER                          | 0  |
| VIDEO STATUS                         | CHOICE                                   |
| PIP SOURCE                           | CH-04                                    |
| PIP ON (PIP POSITION)                | LEFT LOWR SIDE } Only for AV-32260 model |
| <b>2. Setting of MENU</b>            |  |
| <b>PICTURE ADJUST</b>                |  |
| TINT                                 | CENTER                                   |
| COLOR                                | CENTER                                   |
| PICTURE                              | CENTER                                   |
| BRIGHT                               | CENTER                                   |
| DETAIL                               | CENTER                                   |
| NOISE MUTING                         | ON                                       |
| SET VIDEO STATUS                     | ALL CENTER                               |
| <b>SOUND ADJUST</b>                  |  |
| BASS                                 | CENTER                                   |
| TREBLE                               | CENTER                                   |
| BALANCE                              | CENTER                                   |
| MTS                                  | STEREO                                   |
| <b>CLOCK/TIMERS</b>                  |  |
| SET CLOCK                            | Unnecessary to set                       |
| ON/OFF TIMER                         | NO                                       |
| <b>INITIAL SETUP</b>                 |  |
| TV SPEAKER                           | ON                                       |
| COMPONENT-IN                         | NO                                       |
| LANGUAGE                             | ENG                                      |
| CLOSED CAPTION                       | OFF                                      |
| AUTO TUNER SETUP                     | TUNER MODE : AIR                         |
| CHANNEL SUMMARY                      | Unnecessary to set                       |
| V-CHIP                               | OFF                                      |
| SET LOCK CODE                        | Unnecessary to set                       |

# SERVICE ADJUSTMENTS

## ADJUSTMENT PREPARATION:

1. You can make the necessary adjustments for this unit with either the remote control unit or with the adjustment equipment and parts as given below.
2. Adjustment with the remote control unit is made on the basis of the initial setting values, however, the new setting values which set the screen to its optimum condition may differ from the initial settings.
3. Make sure that AC power is turned on correctly.
4. Turn on the power for the set and test equipment before use, and start the adjustment procedures after waiting at least 30 minutes.
5. Unless otherwise specified, prepare the most suitable reception or input signal for adjustment.
6. Never touch any adjustment parts, which are not specified in the list for this adjustment-variable resistors, transformers, capacitors, etc.
7. Presetting before adjustment.

Unless otherwise specified in the adjustment instructions, preset the following functions with the remote control unit.

- User mode setting position

|   |          |
|---|----------|
| VIDEO STATUS                            | STANDARD |
| HYPER SURROUND                          | OFF      |
| BASS, TREBLE, BALANCE                   | CENTER   |
| TINT, COLOR, PICTURE,<br>BRIGHT, DETAIL | CENTER   |

## MEASURING INSTRUMENT

1. DC voltmeter(or digital voltmeter)
2. Oscilloscope
3. Signal generator ( Pattern generator ) [NTSC]
4. Remote control unit
5. TV audio multiplex signal generator
6. Frequency counter
7. Resistor (1M $\Omega$ )

## ADJUSTMENT ITEMS

- Check of B1 POWER SUPPLY
- RF AGC adjustment
- FOCUS adjustment
- WHITE BALANCE adjustment
  - WHITE BALANCE (Low Light) adjustment
  - WHITE BALANCE (High Light) adjustment
  - PIP HIGH LIGHT WHITE BALANCE Adjustment [Only for AV-32260 model]
- BRIGHT adjustment
  - SUB BRIGHT adjustment
- CONTRAST adjustment
  - SUB CONTRAST adjustment
- DEFLECTION adjustment
  - V CENTER and TRAPEZIUM adjustment
  - V-SIZE and V-LINEARITY adjustment
  - H SIZE and H POSITION adjustment
  - SIDE PIN and CORNER PIN adjustment
  - PIP DISPLAY POSITION adjustment [Only for AV-32260 model]
- CHROMA adjustment
  - SUB COLOR adjustment
  - SUB TINT adjustment
- MTS circuit adjustment
  - INPUT LEVEL check
  - STEREO VCO adjustment
  - SAP VCO adjustment
  - FILTER check
  - SEPARATION adjustment
- PURITY and CONVERGENCE adjustments
  - PURITY adjustment
  - STATIC CONVERGENCE adjustment
  - DYNAIC CONVERGENCE adjustment

# ADJUSTMENT LOCATIONS

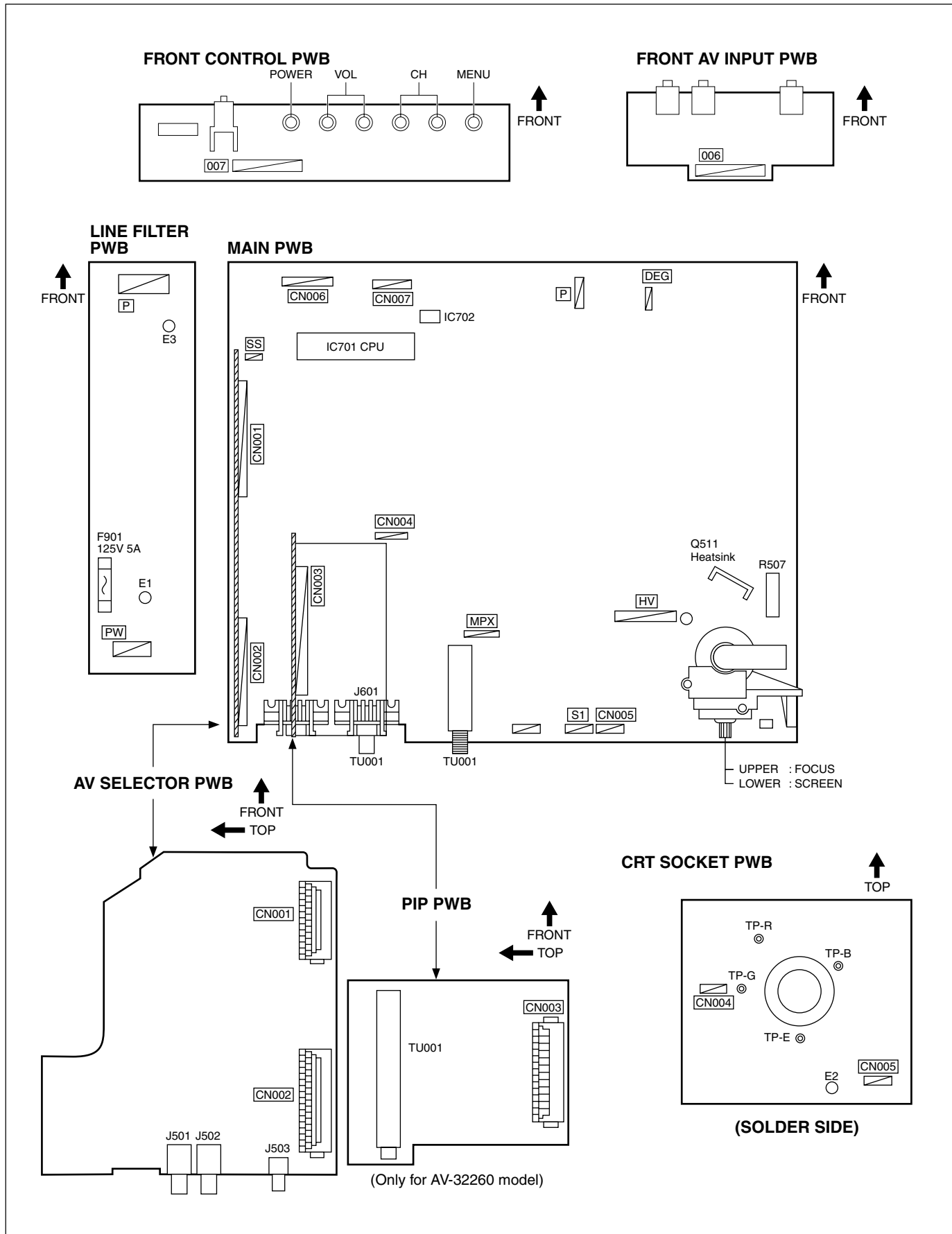

# BASIC OPERATION OF SERVICE MENU

## 1. TOOL OF SERVICE MENU OPERATION

Operate the SERVICE MENU with the REMOTE CONTROL UNIT.

## 2. SERVICE MENU ITEMS

In general, basic setting (adjustments) items or verifications are performed in the SERVICE MENU.

- PICTURE ..... This sets the setting values (adjustment values) of the VIDEO/CHROMA and DEFLECTION circuits.
- SOUND ..... This sets the setting values (adjustment values) of the AUDIO circuit.
- THEATER ..... This is used when the THEATER MODE is adjusted.
- OTHERS ..... This is used when the OTHERS MODE is adjustment.
- PIP ..... This sets the setting values (adjustment values) of the PIP circuit. **[Only for AV-32260 model]**
- LOW LIGHT ..... This sets the setting values (adjustment values) of the WHITE BALANCE circuit.
- HIGH LIGHT ..... This sets the setting values (adjustment values) of the WHITE BALANCE circuit.
- RF AFC ..... This is used when the RF AFC MODE is verified. **[Do not adjust/Only for AV-32230 model]**
- RF AFC1 ..... This is used when the RF AFC1 MODE is verified. **[Do not adjust/Only for AV-32260 model]**
- RF AFC2 ..... This is used when the RF AFC2 MODE is verified. **[Do not adjust/Only for AV-32260 model]**
- VCO (CW) ..... This is not used for service.
- I2C BUS CTRL ..... This is used when ON/OFF of the I2C BUS CTRL is set. **[Fixed ON]**

## 3. Basic Operations of the SERVICE MENU

### (1) How to enter the SERVICE MENU.

Press **SLEEP TIMER** key and, while the indication of “**SLEEP TIMER 0 MIN.**” is being displayed, press **DISPLAY** key and **VIDEO STATUS** key on the remote control unit simultaneously to enter the **SERVICE MENU** screen ① shown in the next figure page.

### (2) SERVICE MENU screen selection

Press the UP / DOWN key of the MENU to select any of the following items.

(The letters of the selected items are displayed in yellow.)

#### [AV-32230]

- PICTURE
- THEATER
- SOUND
- OTHERS
- LOW LIGHT
- RF AFC
- VCO(CW)
- HIGH LIGHT
- I2C BUS CTRL

#### [AV-32260]

- PICTURE
- THEATER
- PIP
- LOW LIGHT
- RF AFC1
- VCO(CW)
- SOUND
- OTHERS
- HIGH LIGHT
- RF AFC2
- I2C BUS CTRL

### (3) Enter the any setting ( adjustment ) mode

#### ● PICTURE, SOUND and OTHERS mode

- 1) If select any of PICTURE, SOUND or OTHERS items, and the LEFT / RIGHT key is pressed from SERVICE MENU ( MAIN MENU ), the screen ② will be displayed as shown in figure page later.
- 2) Then the UP / DOWN key is pressed, the PICTURE mode screen ③ or the SOUND mode screen ④ or the OTHER mode screen ⑤ is displayed, and the PICTURE, SOUND or OTHERS setting can be performed.

#### ● PIP mode [Only for AV-32260 model]

- 1) If select the PIP item, and the LEFT/RIGHT key is pressed from SERVICE MENU (MAIN MENU), the screen ⑥ will be displayed as shown in figure page later.
- 2) Then the UP/DOWN key is pressed, the PIP mode screen ⑦ is displayed, and the PIP setting can be performed.

#### [AV-32230]

#### ● THEATER, LOW LIGHT, HIGH LIGHT, RF AFC, VCO(CW) and I2C BUS CTRL mode

- 1) If select any of THEATER / LOW LIGHT / HIGH LIGHT / RF AFC / VCO (CW) / I2C BUS CTRL items, and the LEFT / RIGHT key is pressed from SERVICE MENU ( MAIN MENU ), the screens ⑧ ⑨ ⑩ ⑪ ⑭ ⑮ will be displayed as shown in figure page later.
- 2) Then the settings or verifications can be performed.

#### [AV-32260]

#### ● THEATER, LOW LIGHT, HIGH LIGHT, RF AFC1, RF AFC2, VCO(CW) and I2C BUS CTRL mode

- 1) If select any of THEATER / LOW LIGHT / HIGH LIGHT / RF AFC1 / RF AFC2 / VCO (CW) / I2C BUS CTRL items, and the LEFT / RIGHT key is pressed from SERVICE MENU ( MAIN MENU ), the screens ⑧ ⑨ ⑩ ⑫ ⑬ ⑭ ⑮ will be displayed as shown in figure page later.
- 2) Then the settings or verifications can be performed.

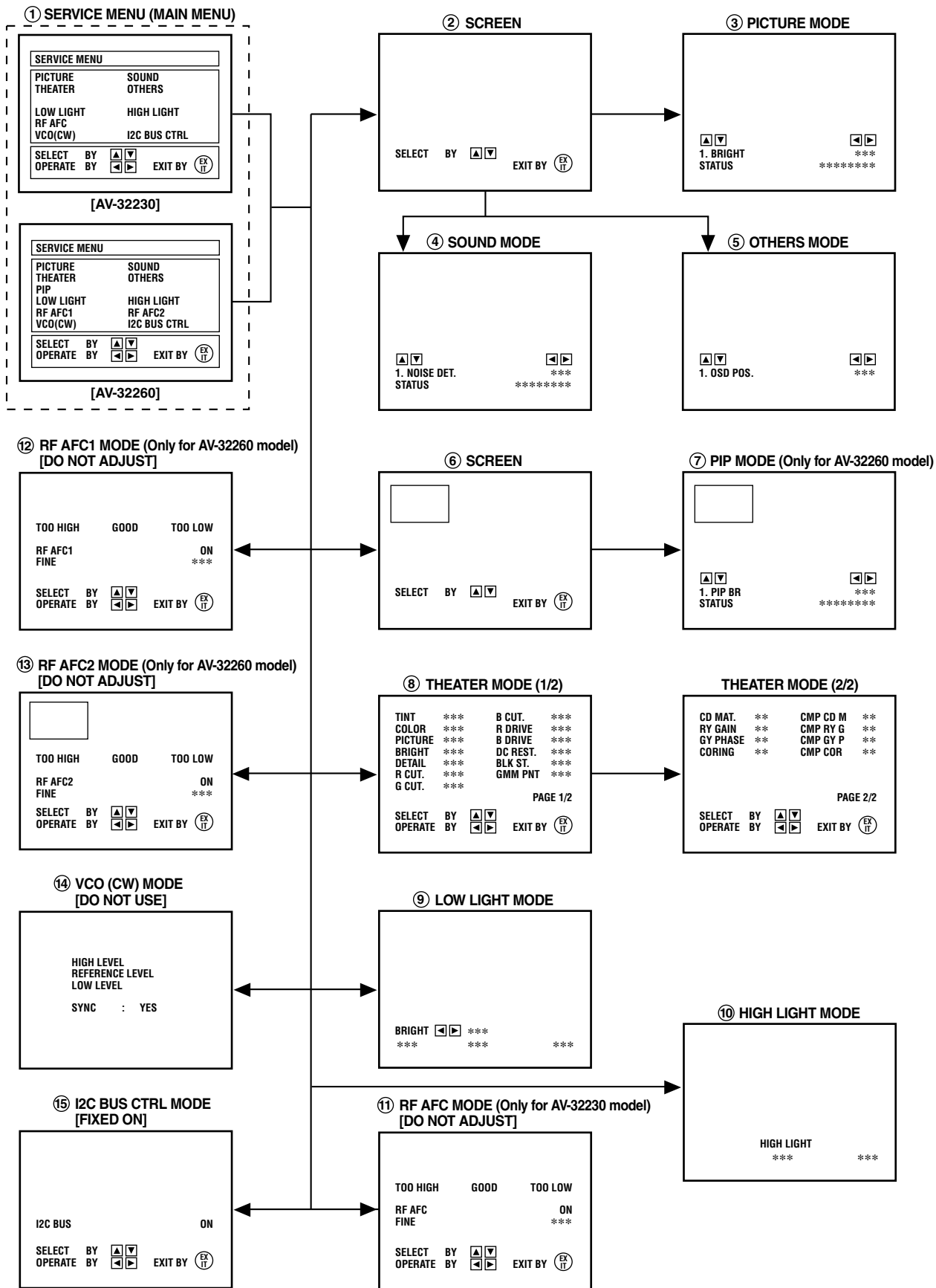

**(4) Setting method**

- 1) UP / DOWN key of the MENU  
Select the SETTING ITEM.
- 2) LEFT / RIGHT key of the MENU  
Setting (adjust) the SETTING VALUE of the SETTING ITEM.  
When the key is released the SETTING VALUE will be stored (memorized).
- 3) EXIT key  
Returns to the previous screen.

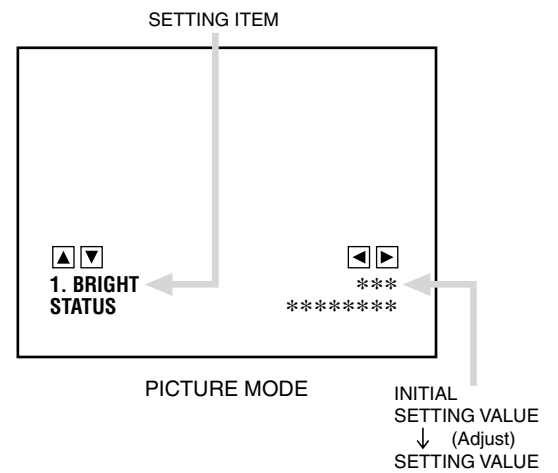

**(5) Releasing SERVICE MENU**

- 1) After returning to the SERVICE MENU upon completion of the setting (adjustment) work, press the EXIT key again.

★ The settings for LOW LIGHT and HIGH LIGHT are described in the WHITE BALANCE page of ADJUSTMENT.

## INITIAL SETTING VALUE OF SERVICE MENU

1. Adjustment of the SERVICE MENU is made on the basis of the initial setting values; however, the new setting values which set the screen in its optimum condition may differ from the initial setting.
2. Do not change the initial setting values of the setting (Adjustment) items not listed in "ADJUSTMENT".

### ● PICTURE MODE

☆ The four setting items in the video mode No.6 EXT BRI., No.7 EXT PIC., No.8 EXT COL. and No.9 EXT TINT are linked to the items in the TV MODE No.1 BRIGHT, No.2 PICTURE, No.3 COLOR and No.4 TINT, respectively. When the setting items in the TV mode are adjusted, the values in the setting items in the video mode are revised automatically to the same values in the TV mode.(The initial setting values given in ( ) are off-set values.)

☆ When the four items (No.6, 7, 8 and 9) are adjusted in the video mode, the setting values in each item are revised independently.

| No. | Setting (Adjustment) item | Variable range | Initial setting value | Remark                                 |
|-----|---------------------------|----------------|-----------------------|--|
| 1   | BRIGHT                    | 000 — 127      | 063                   |  |
| 2   | PICTURE                   | 000 — 127      | 085                   |  |
| 3   | COLOR                     | 000 — 127      | 072                   |  |
| 4   | TINT                      | 000 — 127      | 065                   |  |
| 5   | TV DETAIL                 | 000 — 063      | 045                   |  |
| 6   | EXT BRIGHT                | ±025           | +001                  |  |
| 7   | EXT PICT.                 | ±025           | +002                  |  |
| 8   | EXT COLOR                 | ±025           | +002                  |  |
| 9   | EXT TINT                  | ±025           | -003                  |  |
| 10  | EXT DETAIL                | 000 — 063      | 045                   |  |
| 11  | CMP BRIGHT                | ±025           | -003                  |  |
| 12  | CMP PICT.                 | ±025           | +006                  |  |
| 13  | CMP COLOR                 | 000 — 127      | 089                   | AV-32230 (/G & /M), AV-32260 (/G & /M) |
|     | CMP COLOR                 | 000 — 127      | 087                   | AV-32230 /H, AV-32260 /H               |
| 14  | CMP TINT                  | 000 — 127      | 068                   | AV-32230 /G, AV-32260 /G               |
|     | CMP TINT                  | 000 — 127      | 066                   | AV-32230 /H, AV-32260 /H               |
|     | CMP TINT                  | 000 — 127      | 062                   | AV-32230 /M, AV-32260 /M               |
| 15  | CMP DETAIL                | 000 — 063      | 050                   |  |
| 16  | CMP R CUT                 | ±025           | -011                  |  |
| 17  | CMP G CUT                 | ±025           | ±000                  |  |
| 18  | CMP B CUT                 | ±025           | -001                  |  |
| 19  | CMP R DRV                 | ±025           | ±000                  |  |
| 20  | CMP B DRV                 | ±025           | ±000                  |  |
| 21  | WPL                       | 000 / 001      | 001                   |  |
| 22  | B. B. SW                  | 000 / 001      | 000                   |  |
| 23  | C TRAP                    | 000 / 001      | 000                   |  |
| 24  | CORING                    | 000 / 001      | 000                   |  |
| 25  | CMP CORING                | 000 / 001      | 001                   |  |
| 26  | TV SHARPF                 | 000 / 001      | 001                   |  |
| 27  | EXT SHARPF                | 000 / 001      | 001                   |  |
| 28  | CMP SHARPF                | 000 / 001      | 001                   |  |
| 29  | RGB CONT                  | 000 — 063      | 031                   |  |
| 30  | TV ID SENS                | 000 / 001      | 000                   |  |
| 31  | EXT ID SEN                | 000 / 001      | 001                   |  |
| 32  | F ID                      | 000 / 001      | 000                   |  |
| 33  | Y MUTE                    | 000 / 001      | 000                   |  |
| 34  | AUDIO ATT                 | 000 — 127      | 127                   |  |
| 35  | SUB CONT                  | 000 — 015      | 010                   |  |

| No. | Setting (Adjustment) item | Variable range | Initial setting value | Remark |
|-----|---------------------------|----------------|-----------------------|--------|
| 36  | R Y GAIN                  | 000 / 001      | 001                   |        |
| 37  | CMP R Y GA                | 000 / 001      | 001                   |        |
| 38  | G Y PHASE                 | 000 / 001      | 000                   |        |
| 39  | CMP G Y PH                | 000 / 001      | 000                   |        |
| 40  | CD MATRIX                 | 000 — 003      | 003                   |        |
| 41  | CMP CD MAT                | 000 — 003      | 002                   |        |
| 42  | BLACK ST                  | 000 — 003      | 001                   |        |
| 43  | DC REST                   | 000 — 003      | 001                   |        |
| 44  | COLOR GMM                 | 000 / 001      | 000                   |        |
| 45  | UV/CBCR                   | 000 / 001      | 001                   |        |
| 46  | AT FLESH                  | 000 / 001      | 000                   |        |
| 47  | ABL GAIN                  | 000 — 003      | 000                   |        |
| 48  | ABL ST PNT                | 000 — 003      | 003                   |        |
| 49  | RGB ABCL                  | 000 / 001      | 001                   |        |
| 50  | TV BPF TOF                | 000 / 001      | 000                   |        |
| 51  | EXT BPF TOF               | 000 / 001      | 000                   |        |
| 52  | GMM PNT                   | 000 — 003      | 003                   |        |
| 53  | SVM GAIN                  | 000 — 003      | 003                   |        |
| 54  | CMP SVM GA                | 000 — 003      | 003                   |        |
| 55  | SVM PHASE                 | 000 / 001      | 000                   |        |
| 56  | AUDIO SW                  | 000 / 001      | 000                   |        |
| 57  | BUZZ                      | 000 / 001      | 000                   |        |
| 58  | IF FREQ                   | 000 / 001      | 000                   |        |
| 59  | RF AGC                    | 000 — 063      | 045                   |        |
| 60  | AFT MUTE                  | 000 / 001      | 000                   |        |
| 61  | AFT SENS                  | 000 / 001      | 001                   |        |
| 62  | R/G DRV SW                | 000 / 001      | 001                   |        |
| 63  | BLK SW                    | 000 / 001      | 000                   |        |
| 64  | V S COR                   | 000 — 015      | 012                   |        |
| 65  | V LIN                     | 000 — 015      | 008                   |        |
| 66  | V SIZE                    | 000 — 127      | 065                   |        |
| 67  | V AGC                     | 000 / 001      | 000                   |        |
| 68  | V CENTER                  | 000 — 063      | 053                   |        |
| 69  | TV AFC                    | 000 — 003      | 000                   |        |
| 70  | EXT AFC                   | 000 — 003      | 002                   |        |
| 71  | V POSI                    | 000 — 007      | 000                   |        |
| 72  | H POSI                    | 000 — 031      | 011                   |        |
| 73  | H SIZE                    | 000 — 063      | 023                   |        |
| 74  | TV V FREQ                 | 000 — 003      | 000                   |        |
| 75  | EXT V FREQ                | 000 — 003      | 003                   |        |
| 76  | SIDE PIN                  | 000 — 063      | 027                   |        |
| 77  | STAND BY                  | 000 / 001      | 000                   |        |
| 78  | TRAPEZ                    | 000 — 063      | 035                   |        |
| 79  | V RAMP REF                | 000 / 001      | 001                   |        |
| 80  | V 48HZ                    | 000 / 001      | 000                   |        |
| 81  | V EHT                     | 000 — 007      | 000                   |        |
| 82  | TOP PIN                   | 000 — 031      | 010                   |        |

| No. | Setting (Adjustment) item | Variable range | Initial setting value | Remark |
|-----|---------------------------|----------------|-----------------------|--------|
| 83  | H EHT                     | 000 — 007      | 000                   |        |
| 84  | BTM PIN                   | 000 — 031      | 012                   |        |
| 85  | V BLK LOW                 | 000 — 003      | 000                   |        |
| 86  | V BLK UP                  | 000 — 003      | 000                   |        |
| 87  | CAPTION IN                | 000 / 001      | 000                   |        |
| 88  | H BLK                     | 000 / 001      | 000                   |        |
| 89  | SCREEN                    | 000 / 001      | 000                   |        |
| 90  | ACB SW                    | 000 / 001      | 000                   |        |
| 91  | ACB PULSE                 | 000 — 015      | 007                   |        |
| 92  | OVER MODU                 | 000 / 001      | 001                   |        |
| 93  | APACON LIM                | 000 / 001      | 001                   |        |
| 94  | TEST                      | 000 — 255      | 128                   |        |
| 95  | RF S/N TY                 | 000 — 002      | 002                   |        |
| 96  | EXT S/N TY                | 000 — 002      | 002                   |        |
| 97  | RF SN YC E                | 000 — 255      | 005                   |        |
| 98  | RF SN YC F                | 000 — 255      | 016                   |        |
| 99  | RF SN YC G                | 000 — 063      | 032                   |        |
| 100 | RF SN YC H                | 000 — 255      | 025                   |        |
| 101 | EX SN YC E                | 000 — 255      | 005                   |        |
| 102 | EX SN YC F                | 000 — 255      | 016                   |        |
| 103 | EX SN YC G                | 000 — 063      | 032                   |        |
| 104 | EX SN YC H                | 000 — 255      | 025                   |        |
| 105 | RF SN VC 1                | 000 — 063      | 000                   |        |
| 106 | RF SN VC 2                | 000 — 063      | 007                   |        |
| 107 | RF SN VC 3                | 000 — 063      | 014                   |        |
| 108 | RF SN VC 4                | 000 — 063      | 021                   |        |
| 109 | EX SN VC 1                | 000 — 063      | 000                   |        |
| 110 | EX SN VC 2                | 000 — 063      | 007                   |        |
| 111 | EX SN VC 3                | 000 — 063      | 014                   |        |
| 112 | EX SN VC 4                | 000 — 063      | 021                   |        |
| 113 | COR LEVEL                 | 000 — 003      | 003                   |        |
| 114 | VNR CHK                   | 000 — 255      | 003                   |        |
| 115 | YC SN TIME                | 000 — 255      | 005                   |        |
| 116 | VC SN TIME                | 000 — 255      | 005                   |        |
| 117 | VM DATA A                 | ±127           | +008                  |        |
| 118 | VM DATA B                 | ±127           | -004                  |        |
| 119 | VM DATA C                 | ±127           | -016                  |        |
| 120 | VM DATA D                 | 000 / 001      | 000                   |        |
| 121 | VC SN STOP                | 000 — 255      | 010                   |        |
| 122 | CH MUTE                   | 00/001         | 000                   |        |
| 123 | VM OFF TY                 | 000/001        | 000                   |        |
| 124 | VC VM OFF                 | 000/001        | 001                   |        |
| 125 | YC VM OFF                 | 000 — 255      | 255                   |        |
| 126 | F LOCK                    | 000 — 002      | 002                   |        |
| 127 | VF LOCK EX                | 000/001        | 000                   |        |
| 128 | PURI RGB                  | 000 — 063      | 031                   |        |
| 129 | PURI BCK                  | 000/001        | 000                   |        |

## ● SOUND MODE

| No. | Setting (Adjustment) item | Variable range | Initial setting value | Remark |
|-----|---------------------------|----------------|-----------------------|--------|
| 1   | NOISE DET.                | 000 / 001      | 001                   |        |
| 2   | IN LEVEL                  | 000 — 063      | 025                   |        |
| 3   | FH MONITOR                | 000 / 001      | 000                   |        |
| 4   | STEREO VCO                | 000 — 063      | 030                   |        |
| 5   | PILOT CAN.                | 000 / 001      | 000                   |        |
| 6   | FILTER                    | 000 — 063      | 030                   |        |
| 7   | LOW SEP.                  | 000 — 063      | 028                   |        |
| 8   | HI SEP.                   | 000 — 063      | 025                   |        |
| 9   | 5FH MON.                  | 000 / 001      | 000                   |        |
| 10  | SAP VCO                   | 000 — 063      | 003                   |        |
| 11  | IN GAIN                   | 000 / 001      | 000                   |        |
| 12  | FIL. OFFSET               | ±010           | ±000                  |        |
| 13  | BBE BASS                  | ±010           | +001                  |        |
| 14  | BBE TRE                   | ±010           | +002                  |        |

## ● THEATER MODE

| Setting (Adjustment) item | Variable range | Initial setting value | Remark |
|---------------------------|----------------|-----------------------|--------|
| TINT                      | ±20            | -06                   |        |
| COLOR                     | ±20            | -03                   |        |
| PICTURE                   | ±50            | -15                   |        |
| BRIGHT                    | ±20            | ±00                   |        |
| DETAIL                    | ±20            | +03                   |        |
| R CUT.                    | ±20            | ±00                   |        |
| G CUT.                    | ±20            | ±00                   |        |
| B CUT.                    | ±20            | ±00                   |        |
| R DRIVE                   | ±99            | +07                   |        |
| B DRIVE                   | ±99            | -25                   |        |
| DC REST.                  | 00 — 03        | 01                    |        |
| BLK ST.                   | 00 — 03        | 00                    |        |
| GMM PNT                   | 00 — 03        | 01                    |        |
| CD MATRIX                 | 00 — 03        | 01                    |        |
| RY GAIN                   | 00 / 01        | 01                    |        |
| GY PHASE                  | 00 / 01        | 00                    |        |
| CORING                    | 00 / 01        | 01                    |        |
| CMP CD M                  | 00 — 03        | 01                    |        |
| CMP RY G                  | 00 / 01        | 01                    |        |
| CMP GY P                  | 00 / 01        | 00                    |        |
| CMP COR                   | 00 / 01        | 01                    |        |

● OTHERS MODE

| No. | Setting (Adjustment) item | Variable range | Initial setting value | Remark |
|-----|---------------------------|----------------|-----------------------|--------|
| 1   | OSD POS.                  | 000 — 007      | 002                   |        |
| 2   | CCD POS.                  | 000 — 015      | 003                   |        |
| 3   | EOSEL                     | 000 / 001      | 000                   |        |
| 4   | MENU COLOR                | 000 — -030     | -010                  |        |
| 5   | MENU PICT.                | 000 — -030     | -010                  |        |
| 6   | MENU BRI.                 | 000 — -030     | -010                  |        |

● PIP MODE [Only for AV-32260 model]

| No. | Setting (Adjustment) item | Variable range | Initial setting value | Remark |
|-----|---------------------------|----------------|-----------------------|--------|
| 1   | PIP BR                    | 000 — 015      | 005                   |        |
| 2   | PIP PICT                  | 030 — 045      | 045                   |        |
| 3   | PIP TINT                  | 000 — 063      | 036                   |        |
| 4   | PIP COL                   | 000 — 015      | 010                   |        |
| 5   | P R CUT                   | 000 — 015      | 003                   |        |
| 6   | P G CUT                   | 000 — 015      | 000                   |        |
| 7   | P B CUT                   | 000 — 015      | 002                   |        |
| 8   | P R DR                    | 000 — 255      | 052                   |        |
| 9   | P G DR                    | 000 — 255      | 055                   |        |
| 10  | P B DR                    | 000 — 255      | 060                   |        |
| 11  | LEFT POS.                 | 000 — 255      | 020                   |        |
| 12  | RIGHT POS.                | 000 — 255      | 017                   |        |
| 13  | UPPER POS.                | 000 — 127      | 012                   |        |
| 14  | LOWER POS.                | 000 — 127      | 011                   |        |
| 15  | PICT LOCK                 | 000 / 001      | 001                   |        |
| 16  | SELDEL                    | 000 — 015      | 000                   |        |
| 17  | AGCFIX                    | 000 / 001      | 001                   |        |
| 18  | AGCADST                   | 000 / 001      | 000                   |        |
| 19  | AGC                       | 000 — 015      | 007                   |        |
| 20  | VSPDEL                    | 000 — 031      | 000                   |        |
| 21  | VSPISQ                    | 000 / 001      | 001                   |        |
| 22  | YCOR                      | 000 / 001      | 001                   |        |
| 23  | XFREQF                    | 000 / 001      | 001                   |        |
| 24  | WTCHDG                    | 000 / 001      | 001                   |        |
| 25  | COLON                     | 000 / 001      | 000                   |        |
| 26  | ACQNEW                    | 000 / 001      | 000                   |        |
| 27  | DSTDET                    | 000 / 001      | 001                   |        |
| 28  | CRIBEOK                   | 000 / 001      | 000                   |        |
| 29  | FCBEOK                    | 000 / 001      | 000                   |        |
| 30  | NOCRID                    | 000 / 001      | 000                   |        |
| 31  | NONSED                    | 000 / 001      | 000                   |        |

● **LOW LIGHT MODE**

| Setting (Adjustment) item | Variable range | Initial setting value | Remark |
|---------------------------|----------------|-----------------------|--------|
| R CUTOFF                  | 0 — 255        | 085                   |        |
| G CUTOFF                  | 0 — 255        | 085                   |        |
| B CUTOFF                  | 0 — 255        | 085                   |        |

● **HIGH LIGHT MODE**

| Setting (Adjustment) item | Variable range | Initial setting value | Remark |
|---------------------------|----------------|-----------------------|--------|
| R DRIVE                   | 0 — 127        | 060                   |        |
| B DRIVE                   | 0 — 127        | 060                   |        |

● **RF AFC MODE [Only for AV-32230 model]**

| Setting (Adjustment) item | Variable range | Initial setting value | Remark               |
|---------------------------|----------------|-----------------------|----------------------|
| RF AFC                    | ON / OFF       | ON                    | ( DO NOT<br>ADJUST ) |
| FINE                      | -77 — +77      | ± × ×                 |                      |

● **RF AFC1 MODE [Only for AV-32260 model]**

| Setting (Adjustment) item | Variable range | Initial setting value | Remark               |
|---------------------------|----------------|-----------------------|----------------------|
| RF AFC1                   | ON / OFF       | ON                    | ( DO NOT<br>ADJUST ) |
| FINE                      | -77 — +77      | ± × ×                 |                      |

● **RF AFC2 MODE [Only for AV-32260 model]**

| Setting (Adjustment) item | Variable range | Initial setting value | Remark               |
|---------------------------|----------------|-----------------------|----------------------|
| RF AFC2                   | ON / OFF       | ON                    | ( DO NOT<br>ADJUST ) |
| FINE                      | -77 — +77      | ± × ×                 |                      |

● **I2C BUS CTRL MODE**

| Setting (Adjustment) item | Variable range | Initial setting value | Remark               |
|---------------------------|----------------|-----------------------|----------------------|
| I2C BUS                   | ON/OFF         | [FIXED ON]            | ( DO NOT<br>ADJUST ) |

## ADJUSTMENTS

### B1 POWER SUPPLY

| Item                     | Measuring instrument | Test point                                    | Adjustment part | Description  |
|--------------------------|----------------------|---|-----------------|--|
| Check of B1 POWER SUPPLY | DC Voltmeter         | R507 C504 side (B1)<br><br>Q511 heatsink (77) |                 | <ol style="list-style-type: none"> <li>1. Receive a black-and-white signal.</li> <li>2. Connect the DC Voltmeter to R507 C504 side (B1) and Q511 heatsink (77).</li> <li>3. Confirm that the voltage is DC134V <math>\begin{smallmatrix} +2V \\ -2V \end{smallmatrix}</math>.</li> </ol> |

### ADJUSTMENT OF RF AGC

| Item              | Measuring instrument | Test point | Adjustment part | Description  |
|-------------------|----------------------|------------|-----------------|--|
| RF AGC adjustment |                      |            | No.59 RF AGC    | <ol style="list-style-type: none"> <li>1. Receive a broadcast.</li> <li>2. Select the No.59 RF AGC of the PICTURE MODE.</li> <li>3. Press the MUTE key of the remote control unit and turn off color.</li> <li>4. With the LEFT key of the remote control unit, get noise in the screen picture. (0 side of setting value)</li> <li>5. Press the RIGHT key of the remote control unit and stop when noise disappears from the screen.</li> <li>6. Change to other channels and make sure that there is no irregularity.</li> <li>7. Press the MUTE key and get color out.</li> </ol> |

### ADJUSTMENT OF FOCUS

| Item             | Measuring instrument | Test point | Adjustment part                        | Description  |
|------------------|----------------------|------------|--|--|
| FOCUS adjustment | Signal generator     |            | FOCUS VR [In HVT]<br><br>H VR [In HVT] | <p><b>Notes:</b></p> <ul style="list-style-type: none"> <li>• Proceed to the following this adjustment after having completed the adjustments of B1 POWER SUPPLY, SUB BRIGHT and PICTURE.</li> <li>• Set VIDEO STATUS to "STANDARD".</li> <li>• The final adjustment of CONVERGENCE must be done after the FOCUS adjustment. (CONVERGENCE is changed by FOCUS adjustment.)</li> </ul> <p>When makes difference by FOCUS adjustment, should be reconfirming PURITY adjustment.</p> <ol style="list-style-type: none"> <li>1. Receive a crosshatch signal.</li> <li>2. While looking at the screen center, adjust the FOCUS VR so that the horizontal lines will be clear and in fine detail.</li> <li>3. Adjust the H VR so that the vertical lines will be clear and in fine detail.</li> <li>4. Make sure that the picture is in focus even when the screen gets darkened.</li> </ol> |

**ADJUSTMENT OF WHITE BALANCE**

| Item  | Measuring instrument    | Test point | Adjustment part   | Description   |
|---|-------------------------|------------|---|---|
| <p><b>WHITE BALANCE (Low Light) Adjustment</b></p>  | <p>Signal generator</p> |            | <p><b>No.1 BRIGHT</b></p> <p><b>R CUTOFF</b><br/><b>G CUTOFF</b><br/><b>B CUTOFF</b></p> <p><b>SCREEN VR [In HVT]</b></p> | <p><b>Note :</b><br/>Set VIDEO STATUS to "STANDARD".</p> <ol style="list-style-type: none"> <li>1. Receive a black-and-white signal.(Color off)</li> <li>2. Select the [LOW LIGHT] MODE from the SERVICE MENU.</li> <li>3. Set the initial setting value of BRIGHT is 063 with the LEFT / RIGHT key of the remote control unit.</li> <li>4. Set the initial setting value of R CUTOFF, G CUTOFF and B CUTOFF is 085 with the ④ to ⑨ key of the remote control unit.</li> <li>5. Display a single horizontal line by pressing the ① key of the remote control unit.</li> <li>6. Turn the screen VR all the way to the left.</li> <li>7. Turn the screen VR gradually to the right from the left until either one of the red, blue or green colors appears faintly.</li> <li>8. Adjust the two colors which did not appear until the single horizontal line that is displayed becomes white using the ④ to ⑨ keys of the remote control unit.</li> <li>9. Turn the screen VR to where the single horizontal line glows faintly.</li> <li>10. Press the ② key to return to the regular screen.</li> </ol> <p>* The ③ EXIT key is the cancel key for the WHITE BALANCE.</p> |
| <p><b>WHITE BALANCE (High Light) Adjustment</b></p> | <p>Signal generator</p> |            | <p><b>R DRIVE</b><br/><b>B DRIVE</b></p>  | <p><b>Notes:</b></p> <ul style="list-style-type: none"> <li>• Proceed to the following this adjustment after having completed the adjustment of LOW LIGHT WHITE BALANCE.</li> <li>• Set VIDEO STATUS to "STANDARD".</li> </ul> <ol style="list-style-type: none"> <li>1. Receive a black-and-white signal. (Color off)</li> <li>2. Select the [HIGH LIGHT] MODE from the SERVICE MENU.</li> <li>3. Set the initial setting value of R DRIVE and B DRIVE is 060 with the ④, ⑥, ⑦ and ⑨ keys of the remote control unit.</li> <li>4. Adjust the screen until it becomes white using the ④, ⑥, ⑦ and ⑨ keys of the remote control unit.</li> </ol> <p>* The ③ (EXIT) key is the cancel key for the WHITE BALANCE.</p>  |

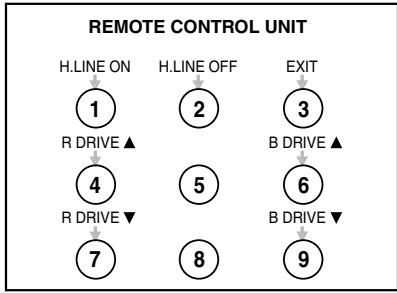
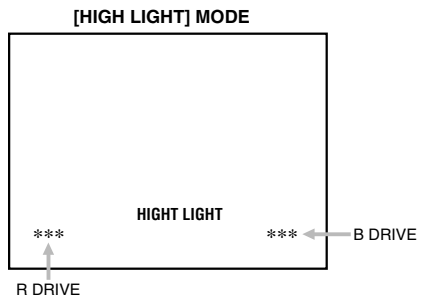
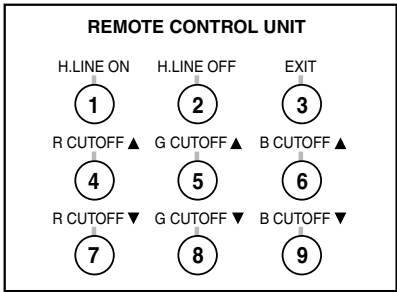
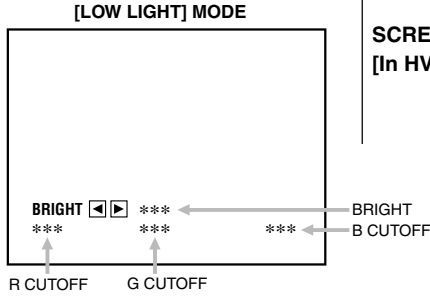

| Item  | Measuring instrument | Test point | Adjustment part             | Description  |
|---|----------------------|------------|-----------------------------|--|
| PIP<br>HIGH LIGHT<br>WHITE<br>BALANCE<br>[AV-32260] | Signal generator     |            | No.8 P R DR<br>No.10 P B DR | <p><b>Notes:</b></p> <ul style="list-style-type: none"> <li>• Proceed to the following this adjustment after having completed the adjustments of LOW LIGHT WHITE BALANCE and HIGH LIGHT WHITE BALANCE for the main picture.</li> <li>• Set VIDEO STATUS to “STANDARD”.</li> </ul> <ol style="list-style-type: none"> <li>1. Receive a black-and-white signal. (Color off)</li> <li>2. Select the PIP MODE from the SERVICE MENU.</li> <li>3. Then adjust the white color of the PIP screen using the No. 8 P R DR and the No. 10 P B DR of the PIP MODE so that it is the same brightness as the main screen.</li> </ol> |

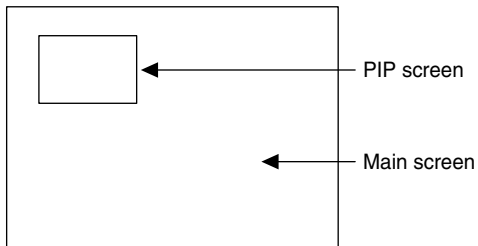

### ADJUSTMENT OF BRIGHT

| Item                     | Measuring instrument | Test point | Adjustment part | Description   |
|--------------------------|----------------------|------------|-----------------|---|
| SUB BRIGHT<br>Adjustment |                      |            | No.1 BRIGHT     | <p><b>Notes:</b></p> <ul style="list-style-type: none"> <li>• Proceed to the following this adjustment after having completed the adjustments of LOW LIGHT WHITE BALANCE and HIGH LIGHT WHITE BALANCE.</li> <li>• Set VIDEO STATUS to “STANDARD”.</li> </ul> <ol style="list-style-type: none"> <li>1. Receive a broadcast.</li> <li>2. Select the No.1 BRIGHT of the PICTURE MODE.</li> <li>3. Set the initial setting value of the No.1 BRIGHT with the LEFT / RIGHT key of the remote control unit.</li> <li>4. If the brightness is not best with the initial setting value, make fine adjustment of the No.1 BRIGHT until you get the optimum brightness.</li> </ol> |

### ADJUSTMENT OF CONTRAST

| Item                          | Measuring instrument | Test point | Adjustment part | Description   |
|-------------------------------|----------------------|------------|-----------------|---|
| SUB<br>CONTRAST<br>Adjustment |                      |            | No.2 PICTURE    | <p><b>Notes:</b></p> <ul style="list-style-type: none"> <li>• Proceed to the following this adjustment after having completed the adjustment of SUB BRIGHT.</li> <li>• Set VIDEO STATUS to “STANDARD”.</li> </ul> <ol style="list-style-type: none"> <li>1. Receive a broadcast.</li> <li>2. Select the No.2 PICTURE of the PICTURE MODE.</li> <li>3. Set the initial setting value of the No.2 PICTURE with the LEFT / RIGHT key of the remote control unit.</li> <li>4. If the contrast is not best with the initial setting value, make fine adjustment of the No.2 PICTURE until you get the optimum contrast.</li> </ol> |

**ADJUSTMENT OF DEFLECTION**

| Item                                     | Measuring instrument    | Test point | Adjustment part                        | Description  |
|--|-------------------------|------------|--|--|
| <b>V CENTER and TRAPEZIUM Adjustment</b> | <b>Signal generator</b> |            | <b>No.68 V CENTER<br/>No.78 TRAPEZ</b> | <p><b>Note:</b><br/>Proceed to the following this adjustment after having completed the adjustments of SUB BRIGHT and SUB CONTRAST.</p> <ol style="list-style-type: none"> <li>1. Receive a crosshatch signal.</li> <li>2. Adjust the No.68 V CENTER of the PICTURE MODE to be the same between the CRT vertical center and crosshatch vertical center.</li> <li>3. Adjust the No.78 TRAPEZ of the PICTUER MODE to be the vertical lines straight.</li> <li>4. Confirm the vertical lines to be straight. If it is not straight, adjust to be straight at the No.78 TRAPEZ.</li> </ol>                                   |
| <b>V-SIZE and V-LINEARITY Adjustment</b> | <b>Signal generator</b> |            | <b>No.66 V SIZE<br/>No.65 V LIN</b>    | <p><b>Note:</b><br/>Proceed to the following this adjustment after having completed the adjustments of SUB BRIGHT and SUB CONTRAST.</p> <ol style="list-style-type: none"> <li>1. Receive a crosshatch signal.</li> <li>2. Select the No.66 V SIZE of the PICTURE MODE to squeeze the laster.</li> <li>3. Adjust the No.65 V LIN of the PICTURE MODE to be symmetrical.</li> <li>4. Adjust the No.66 V SIZE until the vertical screen size is 92%.</li> </ol>  |
| <b>H SIZE and H POSITION Adjustment</b>  | <b>Signal generator</b> |            | <b>No.73 H SIZE<br/>No.72 H POSI</b>   | <p><b>Note:</b><br/>Proceed to the following this adjustment after having completed the adjustments of FOCUS, SUB BRIGHT, SUB CONTRAST, V CENTER, TRAPEZIUM, V-SIZE and V-LINEARITY.</p> <ol style="list-style-type: none"> <li>1. Receive a crosshatch signal.</li> <li>2. Select the No.73 H SIZE of the PICTURE MODE.</li> <li>3. Set the initial setting value of the No.73 H SIZE with the LEFT / RIGHT key of the remote control unit.</li> <li>4. Adjust the No.73 H SIZE until the horizontal screen size is 92%.</li> <li>5. Adjust the No.72 H POSI until the screen will be horizontally centered.</li> </ol> |

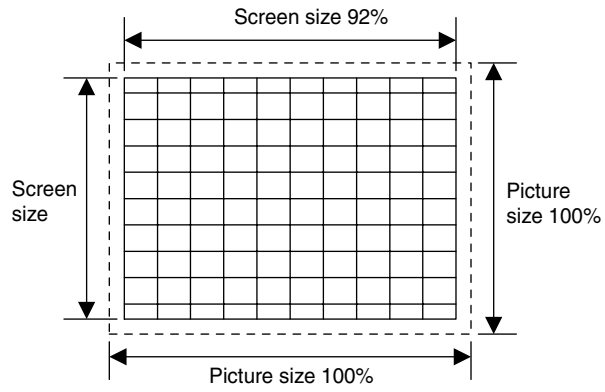
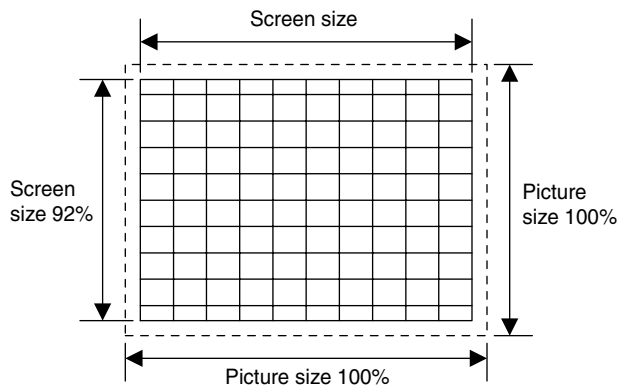
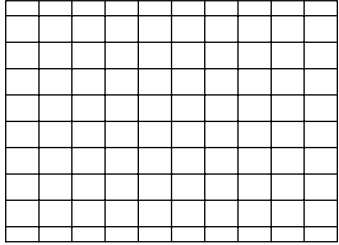

| Item  | Measuring instrument    | Test point | Adjustment part   | Description  |
|---|-------------------------|------------|---|--|
| <b>SIDE PIN and CORNER PIN Adjustment</b>         | <b>Signal generator</b> |            | <b>No.76 SIDE PIN<br/>No.82 TOP PIN<br/>No.84 BTM PIN</b>                             | <p><b>Note:</b><br/>Proceed to the following this adjustment after having completed the adjustments of FOCUS, SUB BRIGHT, SUB CONTRAST, V CENTER, TRAPEZIUM, V-SIZE and V-LINEARITY.</p> <ol style="list-style-type: none"> <li>1. Receive a crosshatch signal.</li> <li>2. Adjust such that vertical 2nd lines from left and right to be straight at the No.76 SIDE PIN of the PICTURE MODE.</li> <li>3. Adjust the end of vertical 2nd lines from left and right to be straight at the No.82 TOP PIN and the No.84 BTM PIN of the PICTURE MODE.</li> </ol> |
| <b>PIP DISPLAY POSITION Adjustment [AV-32260]</b> |                         |            | <b>No.11 LEFT POS.<br/>No.12 RIGHT POS.<br/>No.13 UPPER POS.<br/>No.14 LOWER POS.</b> | <p><b>Notes:</b></p> <ul style="list-style-type: none"> <li>• Proceed to the following this adjustment after having completed the adjustments of V CENTER, TRAPEZIUM, V-SIZE, V-LINEARITY, H SIZE, H POSITION, SIDE PIN and CORNER PIN for the main picture.</li> <li>• Set VIDEO STATUS to "STANDARD".</li> </ul> <ol style="list-style-type: none"> <li>1. Receive a broadcast.</li> <li>2. Select the PIP MODE from the SERVICE MENU.</li> <li>3. Then adjust the PIP screen size so that it occupies 80% ± 2% of the main screen area.</li> </ol>        |

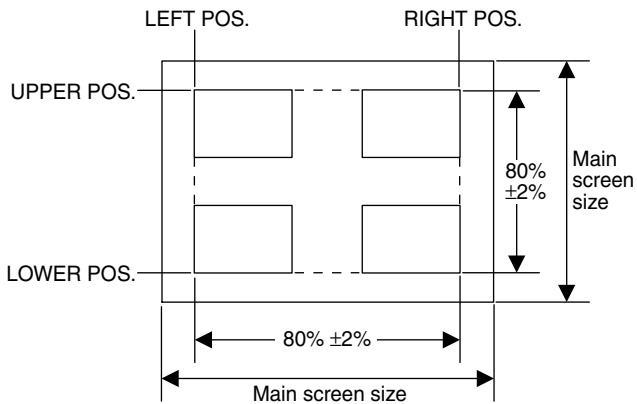
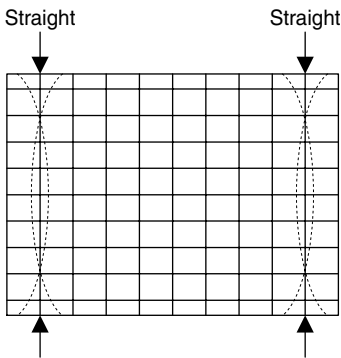

**ADJUSTMENT OF CHROMA**

| Item  | Measuring instrument                                    | Test point  | Adjustment part | Description  |  |                        |   |     |   |     |   |      |
|---|---|---|-----------------|--|--|------------------------|---|-----|---|-----|---|------|
| SUB COLOR adjustment  | Signal generator<br>Oscilloscope<br>Remote control unit | TP-B<br>TP-E ( $\overline{TT}$ )<br>[CRT SOCKET<br>PWB] | No.3 COLOR      | <p><b>Notes:</b></p> <ul style="list-style-type: none"> <li>• Proceed to the following this adjustment after having completed the adjustment of CONTRAST.</li> <li>• Set VIDEO STATUS to "STANDARD".</li> </ul> <p><b>[ Method of adjustment without measuring instrument ]</b></p> <ol style="list-style-type: none"> <li>1. Receive a broadcast.</li> <li>2. Select the No.3 COLOR of the PICTURE MODE.</li> <li>3. Set the initial setting value of the No.3 COLOR with the LEFT/RIGHT key of the remote control unit.</li> <li>4. If the color is not the best with the Initial setting value, make fine adjustment of the No.3 COLOR until you get the optimum color.</li> </ol>  |  |                        |   |     |   |     |   |      |
|   |   |   |                 | <p><b>Notes:</b></p> <ul style="list-style-type: none"> <li>• Proceed to the following this adjustment after having completed the adjustment of CONTRAST.</li> <li>• Set VIDEO STATUS to "STANDARD".</li> </ul> <p><b>[ Method of adjustment using measuring instrument ]</b></p> <ol style="list-style-type: none"> <li>1. Input the full field color bar signal (75% white).</li> <li>2. Select the No.3 COLOR of the PICTURE MODE.</li> <li>3. Set the initial setting value of the No.3. COLOR with the LEFT/RIGHT key of the remote control unit.</li> <li>4. Connect the oscilloscope between TP-B and TP-E.</li> <li>5. Adjust COLOR and bring the value of (A) in the illustration to the voltage shown in the table 1.</li> </ol> |  |                        |   |     |   |     |   |      |
|   |   |   |                 |  |  |                        |   |     |   |     |   |      |
| <table border="1"> <thead> <tr> <th></th> <th>A (V<sub>W-B</sub>)</th> </tr> </thead> <tbody> <tr> <td>AV-32260<sub>G</sub>, AV-32230<sub>G</sub></td> <td>+8V</td> </tr> <tr> <td>AV-32260<sub>H</sub>, AV-32230<sub>H</sub></td> <td>+6V</td> </tr> <tr> <td>AV-32260<sub>M</sub>, AV-32230<sub>M</sub></td> <td>+7V</td> </tr> </tbody> </table> <p><b>Table 1</b></p>   |   |   |                 |  |  | A (V <sub>W-B</sub> )  | AV-32260 <sub>G</sub> , AV-32230 <sub>G</sub> | +8V | AV-32260 <sub>H</sub> , AV-32230 <sub>H</sub> | +6V | AV-32260 <sub>M</sub> , AV-32230 <sub>M</sub> | +7V  |
|   | A (V <sub>W-B</sub> )                                   |   |                 |  |  |                        |   |     |   |     |   |      |
| AV-32260 <sub>G</sub> , AV-32230 <sub>G</sub>   | +8V   |   |                 |  |  |                        |   |     |   |     |   |      |
| AV-32260 <sub>H</sub> , AV-32230 <sub>H</sub>   | +6V   |   |                 |  |  |                        |   |     |   |     |   |      |
| AV-32260 <sub>M</sub> , AV-32230 <sub>M</sub>   | +7V   |   |                 |  |  |                        |   |     |   |     |   |      |
| SUB TINT adjustment   | Signal generator<br>Oscilloscope<br>Remote control unit | TP-B<br>TP-E ( $\overline{TT}$ )<br>[CRT SOCKET<br>PWB] | No.4 TINT       | <p><b>Notes:</b></p> <ul style="list-style-type: none"> <li>• Proceed to the following this adjustment after having completed the adjustment of CONTRAST.</li> <li>• Set VIDEO STATUS to "STANDARD".</li> </ul> <p><b>[ Method of adjustment without measuring instrument ]</b></p> <ol style="list-style-type: none"> <li>1. Receive a broadcast.</li> <li>2. Select the No.4 TINT of the PICTURE MODE.</li> <li>3. Set the initial setting value of the No.4 TINT with the LEFT/RIGHT key of the remote control unit.</li> <li>4. If the tint is not the best with the initial setting value, make fine adjustment of the No.4 TINT until you get the optimum tint.</li> </ol>   |  |                        |   |     |   |     |   |      |
|   |   |   |                 | <p><b>Notes:</b></p> <ul style="list-style-type: none"> <li>• Proceed to the following this adjustment after having completed the adjustment of CONTRAST.</li> <li>• Set VIDEO STATUS to "STANDARD".</li> </ul> <p><b>[ Method of adjustment using measuring instrument ]</b></p> <ol style="list-style-type: none"> <li>1. Input the full field color bar signal (75% white).</li> <li>2. Select the No.4 TINT of the PICTURE MODE.</li> <li>3. Set the initial setting value of the No.4 TINT with the LEFT/RIGHT key to the remote control unit.</li> <li>4. Connect the oscilloscope between TP-B and TP-E.</li> <li>5. Adjust TINT and bring the value of (B) in the illustration to the voltage shown in the table 2.</li> </ol>     |  |                        |   |     |   |     |   |      |
|   |   |   |                 |  |  |                        |   |     |   |     |   |      |
| <table border="1"> <thead> <tr> <th></th> <th>B (V<sub>W-Mg</sub>)</th> </tr> </thead> <tbody> <tr> <td>AV-32260<sub>G</sub>, AV-32230<sub>G</sub></td> <td>+8V</td> </tr> <tr> <td>AV-32260<sub>H</sub>, AV-32230<sub>H</sub></td> <td>+8V</td> </tr> <tr> <td>AV-32260<sub>M</sub>, AV-32230<sub>M</sub></td> <td>+11V</td> </tr> </tbody> </table> <p><b>Table 2</b></p> |   |   |                 |  |  | B (V <sub>W-Mg</sub> ) | AV-32260 <sub>G</sub> , AV-32230 <sub>G</sub> | +8V | AV-32260 <sub>H</sub> , AV-32230 <sub>H</sub> | +8V | AV-32260 <sub>M</sub> , AV-32230 <sub>M</sub> | +11V |
|   | B (V <sub>W-Mg</sub> )                                  |   |                 |  |  |                        |   |     |   |     |   |      |
| AV-32260 <sub>G</sub> , AV-32230 <sub>G</sub>   | +8V   |   |                 |  |  |                        |   |     |   |     |   |      |
| AV-32260 <sub>H</sub> , AV-32230 <sub>H</sub>   | +8V   |   |                 |  |  |                        |   |     |   |     |   |      |
| AV-32260 <sub>M</sub> , AV-32230 <sub>M</sub>   | +11V  |   |                 |  |  |                        |   |     |   |     |   |      |

### ADJUSTMENT OF MTS CIRCUIT

| Item                             | Measuring instrument  | Test point  | Adjustment part                                      | Description  |
|----------------------------------|---|---|--|--|
| <b>MTS INPUT LEVEL check</b>     |   |   | <b>No.2 IN LEVEL</b>                                 | <ol style="list-style-type: none"> <li>1. Select the No.2 IN LEVEL of the SOUND MODE.</li> <li>2. Verify that the No.2 IN LEVEL is set at its initial setting value.</li> </ol>  |
| <b>MTS STEREO VCO adjustment</b> | <b>Signal generator</b><br><br><b>Frequency counter</b>               | <b>[MPX] Connector</b><br><b>2 pin AUDIO R</b><br><b>3 pin GND</b>                          | <b>No.3 FH MONITOR</b><br><br><b>No.4 STEREO VCO</b> | <p><b>Note:</b> Menu "MTS" is set to "STEREO"</p> <ol style="list-style-type: none"> <li>1. Receive a RF signal (nonmodulated sound signal) from the antenna terminal.</li> <li>2. Select the No.3 FH MONITOR of SOUND MODE, and change the setting value from 0 to 1.</li> <li>3. Connect the Frequency Counter to pin 2 of [MPX] connector and GND (Pin 3 of [MPX] connector).</li> <li>4. Select the No.4 STEREO VCO.</li> <li>5. Set the initial setting value of the No.4 STEREO VCO with the LEFT/RIGHT key of the remote control unit.</li> <li>6. Adjust the No.4 STEREO VCO so that the frequency counter will display 15.73kHz±0.1kHz.</li> <li>7. Select the No.3 FH MONITOR of the SOUND MODE, and reset the setting value from 1 to 0.</li> </ol>   |
| <b>MTS SAP VCO adjustment</b>    | <b>Signal generator</b><br><br><b>Frequency counter</b>               | <b>[MPX] Connector</b><br><b>4 pin TP_952.5</b><br><b>3 pin GND</b><br><b>2 pin AUDIO_R</b> | <b>No.9 5FH MON.</b><br><br><b>No.10 SAP VCO</b>     | <ol style="list-style-type: none"> <li>1. Receive a RF signal (non modulated sound signal) from the antenna terminal.</li> <li>2. Connect between pin 4 of [MPX] connector and GND (Pin 3 of [MPX] connector) through 1MΩ Resistor.</li> <li>3. Select the No.9 5FH MON. of the SOUND MODE, and reset the setting value from 0 to 1.</li> <li>4. Connect the Frequency Counter to pin 2 of [MPX] connector and GND (Pin 3 of [MPX] connector) .</li> <li>5. Select the No.10 SAP VCO.</li> <li>6. Set the initial setting value of the No.10 SAP VCO with the LEFT/RIGHT key of the remote control unit.</li> <li>7. Adjust the No.10 SAP VCO so that the frequency counter will display 78.67kHz±0.5kHz.</li> <li>8. Select the No.9 5FH MON. of the SOUND MODE, and reset the setting value from 1 to 0.</li> </ol>  |
| <b>MTS FILTER check</b>          |   |   | <b>No.6 FILTER</b>                                   | <ol style="list-style-type: none"> <li>1. Select the No.6 FILTER of the SOUND MODE.</li> <li>2. Verify that the No.6 FILTER is set at its initial setting value.</li> </ol>  |
| <b>MTS SEPARATION adjustment</b> | <b>TV audio multiplex signal generator</b><br><br><b>Oscilloscope</b> | <b>[MPX] Connector</b><br><b>1 pin AUDIO_L</b><br><b>2 pin AUDIO_R</b><br><b>3 pin GND</b>  | <b>No.7 LOW SEP.</b><br><br><b>No.8 HI SEP.</b>      | <p><b>Note:</b> Menu "MTS" is set to "STEREO"</p> <ol style="list-style-type: none"> <li>1. Input a stereo L signal (300Hz) from the TV audio multiplex signal generator to the antenna terminal.</li> <li>2. Connect an oscilloscope to pin 1 of [MPX] connector, and display one cycle portion of the 300Hz signal.</li> <li>3. Change the connection of the oscilloscope to pin 2 of [MPX] connector, and enlarge the voltage axis.</li> <li>4. Select the No.7 LOW SEP. of the SOUND MODE.</li> <li>5. Set the initial setting value of the No.7 LOW SEP. with the LEFT/RIGHT key of the remote control unit.</li> <li>6. Adjust the No.7 LOW SEP. so that the 300Hz signal level will become minimum.</li> <li>7. Change the signal to 3kHz, and connect an oscilloscope to pin 1 of [MPX] connector.</li> <li>8. Adjust the No.8 HI SEP. so that the 3kHz signal level will become minimum.</li> </ol> |

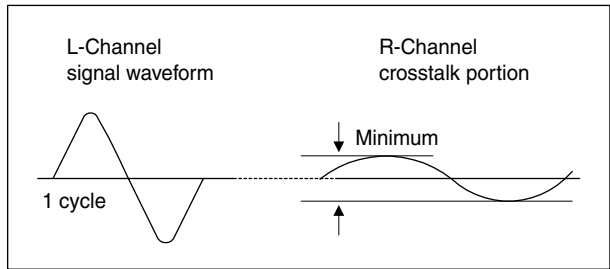

## ADJUSTMENTS OF PURITY AND CONVERGENCE

**Note:** The final adjustment of CONVERGENCE must be done after the FOCUS adjustment. (CONVERGENCE is changed by FOCUS adjustment.)  
When makes difference by FOCUS adjustment, should be reconfirming PURITY adjustment.

### PURITY ADJUSTMENT

1. Demagnetize CRT with the demagnetizer.
2. Loosen the retainer screw of the deflection yoke.
3. Remove the wedges.
4. Input a green raster signal from the signal generator, and turn the screen to green raster.
5. Move the deflection yoke backward.
6. Bring the long lug of the purity magnets on the short lug and position them horizontally. (Fig.2)
7. Adjust the gap between two lugs so that the GREEN RASTER will come into the center of the screen. (Fig.3)
8. Move the deflection yoke forward, and fix the position of the deflection yoke so that the whole screen will become green.
9. Insert the wedge to the top side of the deflection yoke so that it will not move.
10. Input a crosshatch signal.
11. Verify that the screen is horizontal.
12. Input red and blue raster signals, and make sure that purity is properly adjusted.

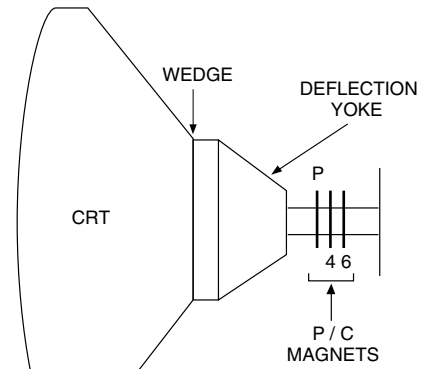

• P/C MAGNETS

|   |                                 |
|---|---------------------------------|
| P | : PURITY MAGNET                 |
| 4 | : 4 POLES (convergence magnets) |
| 6 | : 6 POLES (convergence magnets) |

Fig. 1

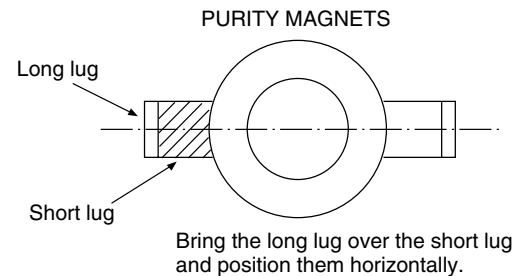

Fig. 2

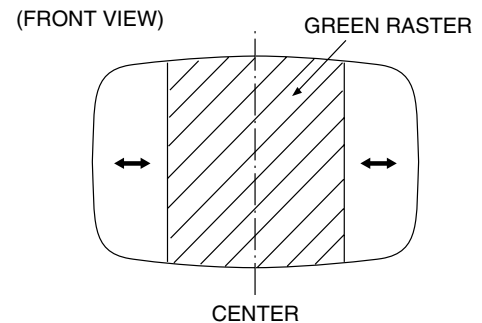

Fig. 3

### STATIC CONVERGENCE ADJUSTMENT

1. Input a crosshatch signal.
2. Using 4-pole convergence magnets, overlap the red and blue lines in the center of the screen (Fig. 4) and turn them to magenta (red/blue).
3. Using 6-pole convergence magnets, overlap the magenta (red/blue) and green lines in the center of the screen and turn them to white.
4. Repeat 2 and 3 above, and make best convergence.

### DYNAMIC CONVERGENCE ADJUSTMENT

1. Move the deflection yoke up and down and overlap the lines in the periphery. (Fig. 5)
  2. Move the deflection yoke left to right and overlap the lines in the periphery. (Fig. 6)
  3. Repeat 1 and 2 above, and make best convergence.
- After adjustment, fix the wedge at the original position.  
Fasten the retainer screw of the deflection yoke.  
Fix the 6 magnets with glue.

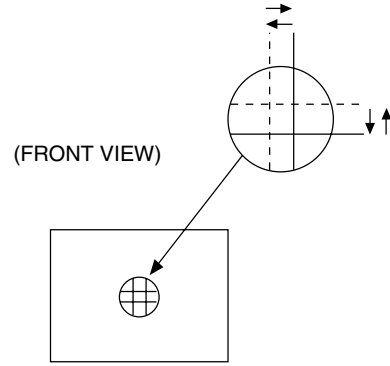

Fig. 4

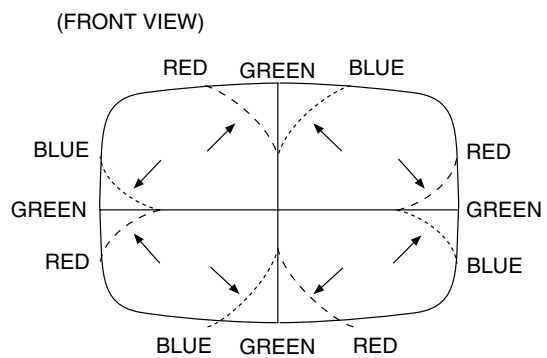

Fig. 5

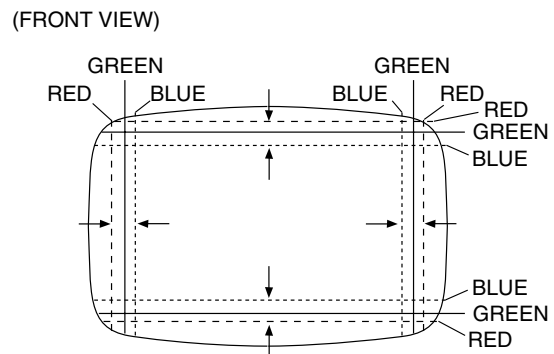

Fig. 6

# HOW TO CHECK THE HIGH VOLTAGE HOLD DOWN CIRCUIT

## 1. HIGH VOLTAGE HOLD DOWN CIRCUIT

After repairing the high voltage hold down circuit shown in Fig. 1.  
This circuit shall be checked to operate correctly.

## 2. CHECKING OF THE HIGH VOLTAGE HOLD DOWN CIRCUIT

- (1) Turn the POWER SW ON.
- (2) As shown in Fig. 1, set the resistor (between [S1] connector [2] & [3] ).
- (3) Make sure that the screen picture disappears.
- (4) Temporarily unplug the power cord.
- (5) Remove the resistor (between [S1] connector [2] & [3] ).
- (6) Again plug the power cord, make sure that the normal picture is displayed on the screen.

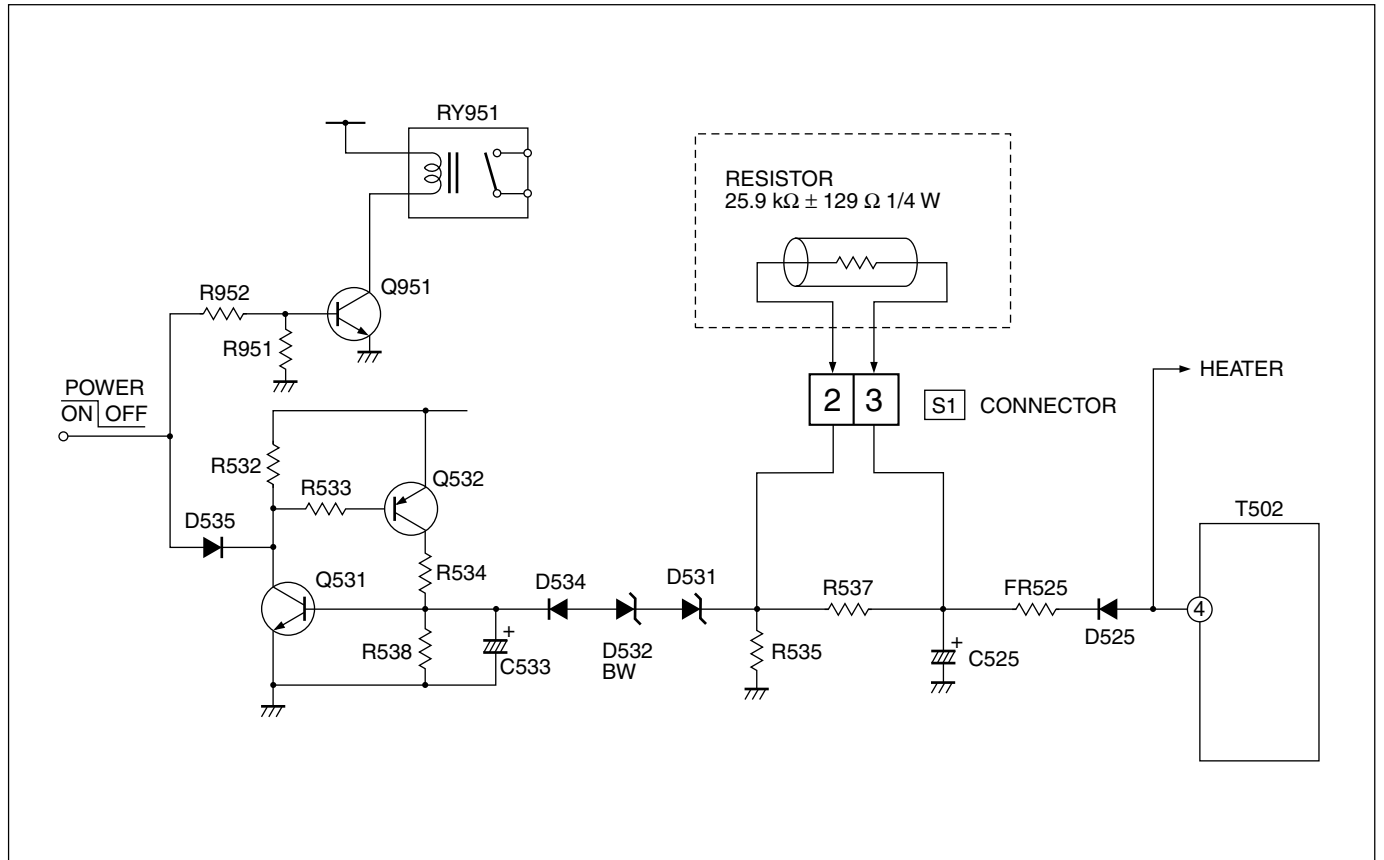

Fig. 1

# SELF CHECK FUNCTIONS

## 1. Outline

This model has self check functions given below. When a malfunction has been detected, the POWER is turned off and the LED flashes to inform of the failure. The malfunction is detected by the signal input state of the control line connected to the microcomputer.

## 2. Self check items

| Check item             | Details of detection               | Method of detection   | State of malfunction  |
|------------------------|------------------------------------|---|---|
| Over-current protector | Operation of B1 protector circuit. | The microcomputer detects at 1 second intervals.<br>If NG is detected for more than 200 ms, a malfunction is interpreted. | When a malfunction has been detected, the POWER is turned off. While the POWER is being turned off, the power key of the remote controller is not operational until the power code is taken out and put in again. |

## 3. Self check indicating function

The self-check function begins detection about 5 seconds after power is supplied.

In the event a malfunction is detected, the power is cut off immediately.

At this time, the ON-TIMER LED flashes to inform of the malfunction.

### [ON-TIMER LED indication]

The ON-TIMER LED flashes at 0.5 seconds intervals.

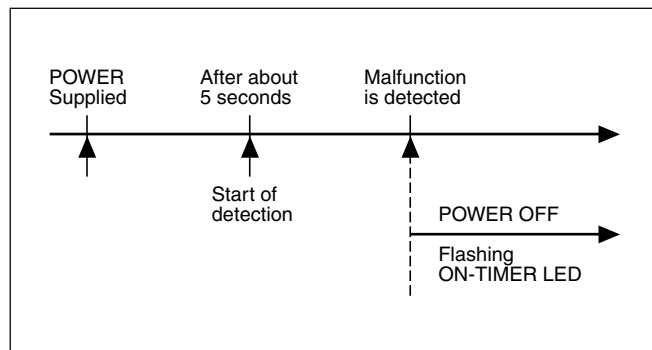

# PARTS LIST

## CAUTION

- The parts identified by the  $\triangle$  symbol are important for the safety . Whenever replacing these parts, be sure to use specified ones to secure the safety .
- The parts not indicated in this Parts List and those which are filled with lines --- in the Parts No. columns will not be supplied .
- P. W. Board Ass'y will not be supplied, but those which are filled with the Parts No. in the Parts No. columns will be supplied .

## ABBREVIATIONS OF RESISTORS, CAPACITORS AND TOLERANCES

| RESISTORS |  | CAPACITORS      |   |
|-----------|--|-----------------|---|
| C R       | Carbon Resistor                                  | C CAP.          | Ceramic Capacitor                             |
| F R       | Fusible Resistor                                 | E CAP.          | Electrolytic Capacitor                        |
| P R       | Plate Resistor                                   | M CAP.          | Mylar Capacitor                               |
| V R       | Variable Resistor                                | HV CAP.         | High Voltage Capacitor                        |
| HV R      | High Voltage Resistor                            | MF CAP.         | Metalized Film Capacitor                      |
| MF R      | Metal Film Resistor                              | MM CAP.         | Metalized Mylar Capacitor                     |
| MG R      | Metal Glazed Resistor                            | MP CAP.         | Metalized Polystyrol Capacitor                |
| MP R      | Metal Plate Resistor                             | PP CAP.         | Polypropylene Capacitor                       |
| OM R      | Metal Oxide Film Resistor                        | PS CAP.         | Polystyrol Capacitor                          |
| CMF R     | Coating Metal Film Resistor                      | TF CAP.         | Thin Film Capacitor                           |
| UNF R     | Non-Flammable Resistor                           | MPP CAP.        | Metalized Polypropylene Capacitor             |
| CH V R    | Chip Variable Resistor                           | TAN. CAP.       | Tantalum Capacitor                            |
| CH MG R   | Chip Metal Glazed Resistor                       | CH C CAP.       | Chip Ceramic Capacitor                        |
| COMP. R   | Composition Resistor                             | BP E CAP.       | Bi-Polar Electrolytic Capacitor               |
| LPTC R    | Linear Positive Temperature Coefficient Resistor | CH AL E CAP.    | Chip Aluminum Electrolytic Capacitor          |
|           |  | CH AL BP CAP.   | Chip Aluminum Bi-Polar Capacitor              |
|           |  | CH TAN. E CAP.  | Chip Tantalum Electrolytic Capacitor          |
|           |  | CH AL BP E CAP. | Chip Tantalum Bi-Polar Electrolytic Capacitor |

| RESISTORS |     |     |      |      |      |              |              |              |             |
|-----------|-----|-----|------|------|------|--------------|--------------|--------------|-------------|
| F         | G   | J   | K    | M    | N    | R            | H            | Z            | P           |
| ±1%       | ±2% | ±5% | ±10% | ±20% | ±30% | +30%<br>-10% | +50%<br>-10% | +80%<br>-20% | +100%<br>0% |

# CONTENTS

|  |           |
|--|-----------|
| <b>USING P.W. BOARD &amp; REMOTE CONTROL UNIT .....</b>              | <b>37</b> |
| <b>EXPLODED VIEW PARTS LIST .....</b>                                | <b>38</b> |
| <b>EXPLODED VIEW .....</b>   | <b>39</b> |
| <br>   |           |
| <b>PRINTED WIRING BOARD PARTS LIST (AV-36230/H)</b>                  |           |
| MAIN PW BOARD ASS'Y .....  | 40        |
| CRT SOCKET PW BOARD ASS'Y .....                                      | 43        |
| FRONT CONTROL PW BOARD ASS'Y .....                                   | 43        |
| FRONT AV INPUT PW BOARD ASS'Y .....                                  | 43        |
| LF PW BOARD ASS'Y .....  | 44        |
| AV SELECTOR PW BOARD ASS'Y .....                                     | 44        |
| <b>REMOTE CONTROL UNIT PARTS LIST (RM-C306-1A) .....</b>             | <b>45</b> |
| <b>DIFFERENCE PARTS LIST BETWEEN AV-36230/H AND AV-36230/R .....</b> | <b>46</b> |
| <br>   |           |
| <b>PRINTED WIRING BOARD PARTS LIST (AV-36260/R)</b>                  |           |
| MAIN PW BOARD ASS'Y .....  | 47        |
| CRT SOCKET PW BOARD ASS'Y .....                                      | 50        |
| FRONT CONTROL PW BOARD ASS'Y .....                                   | 50        |
| FRONT AV INPUT PW BOARD ASS'Y .....                                  | 50        |
| LF PW BOARD ASS'Y .....  | 51        |
| PIP PW BOARD ASS'Y .....   | 51        |
| AV SELECTOR PW BOARD ASS'Y .....                                     | 51        |
| <b>REMOTE CONTROL UNIT PARTS LIST (RM-C305-1A) .....</b>             | <b>53</b> |
| <b>DIFFERENCE PARTS LIST BETWEEN AV-36260/R AND AV-36260/H .....</b> | <b>54</b> |
| <br>   |           |
| <b>PACKING / PACKING PARTS LIST .....</b>                            | <b>55</b> |

## USING P.W. BOARD & REMOTE CONTROL UNIT

### [AV-36230]

| <b>P.W.B ASS'Y</b>      | <b>Model</b> | <b>AV-36230/H</b> | <b>AV-36230/R</b> |
|-------------------------|--------------|-------------------|-------------------|
| MAIN PW BOARD           |              | SAC-1540A-M2      | SAC-1539A-M2      |
| CRT SOCKET PW BOARD     |              | SAC-3505A-M2      | SAC-3504A-M2      |
| FRONT CONTROL PW BOARD  |              | SAC-8506A-M2      | ←                 |
| FRONT AV INPUT PW BOARD |              | SAC-8604A-M2      | ←                 |
| LF PW BOARD             |              | SAC-9502A-M2      | ←                 |
| AV SELECTOR PW BOARD    |              | SAC0S510A-M2      | ←                 |
| REMOTE CONTROL UNIT     |              | RM-C306-1A        | ←                 |

### [AV-36260]

| <b>P.W.B ASS'Y</b>      | <b>Model</b> | <b>AV-36260/H</b> | <b>AV-36260/R</b> |
|-------------------------|--------------|-------------------|-------------------|
| MAIN PW BOARD           |              | SAC-1534A-M2      | SAC-1533A-M2      |
| CRT SOCKET PW BOARD     |              | SAC-3505A-M2      | SAC-3504A-M2      |
| FRONT CONTROL PW BOARD  |              | SAC-8506A-M2      | ←                 |
| FRONT AV INPUT PW BOARD |              | SAC-8604A-M2      | ←                 |
| LF PW BOARD             |              | SAC-9502A-M2      | ←                 |
| PIP PW BOARD            |              | SAC0P502A-M2      | ←                 |
| AV SELECTOR PW BOARD    |              | SAC0S509A-M2      | ←                 |
| REMOTE CONTROL UNIT     |              | RM-C305-1A        | ←                 |

## EXPLODED VIEW PARTS LIST (AV-36230 & AV-36260)

| △ Ref.No. | Part No.       | Part Name       | Description  | Local |
|-----------|----------------|-----------------|--|-------|
| △ L01     | CELD067-001JA  | DEG COIL        |  |       |
| △ T1502   | QQH0092-001    | FBT             |  |       |
| △ V01     | A90LPY30X04    | CRT             | Inc. DY (AV-36230 <sup>H</sup> , AV-36260 <sup>H</sup> ) |       |
| △ V01     | A90AEJ15X01    | CRT             | Inc. DY (AV-36230 <sup>R</sup> , AV-36260 <sup>R</sup> ) |       |
| △ 1       | QMPD200-200-JC | POWER CORD      | CN90PW Within LF PWB                                     |       |
| △ 2       | CM35983-001-H  | REMOCON WINDOW  |  |       |
| △ 3       | CM46084-A01    | JVC MARK        |  |       |
| △ 4       | CM35776-B01-H  | CONTROL KNOB    |  |       |
| 5         | A48457-4-S     | SPRING          |  |       |
| 6         | WJY0016-003A   | BRAIDED WIRE    |  |       |
| 7         | WJY0013-005A   | BRAIDED WIRE    |  |       |
| △ 8       | CEBSS12D-02J2  | SPEAKER         | (x2) SP01, SP02  |       |
| △ 9       | LC11056-002B-A | CHASSIS BASE    |  |       |
| △ 10      | LC20626-004B-A | TERMINAL BOARD  |  |       |
| △ 11      | QYSBSB3010Z    | TAPPING SCREW   | (x4)   |       |
| △ 12      | CHGY0031-0C    | ANT CABLE ASSY  | (Only for AV-36260 model)                                |       |
| △ 13      | CM12634-006-MA | REAR COVER      |  |       |
| △ 14      | QYSBSFG4016Z   | TAPPING SCREW   | (x11)  |       |
| △ 15      | LC31139-001A-A | RATING LABEL    |  |       |
| △ 16      | LC20106-001D-A | CORD CLAMP      |  |       |
| △ 17      | QYSBSB4012Z    | TAPPING SCREW   | (x4)   |       |
| △ 100     | CM12747-A0G-MA | FRONT CABI ASSY | Inc. No. 101   |       |
| 101       | CM36162-005-A  | DOOR            |  |       |



**PRINTED WIRING BOARD PARTS LIST (AV-36230/H)****MAIN PW BOARD ASS'Y (SAC-1540A-M2)**

| △               | Symbol No. | Part No.     | Part Name | Description | Local | △               | Symbol No. | Part No.      | Part Name   | Description       | Local  |   |
|-----------------|------------|--------------|-----------|-------------|-------|-----------------|------------|---------------|-------------|-------------------|--------|---|
| <b>RESISTOR</b> |            |              |           |             |       | <b>RESISTOR</b> |            |               |             |                   |        |   |
|                 | R1001      | NRSA63J-473X | MG R      | 47kΩ 1/16W  | J     |                 | R1522      | NRSA63J-561X  | MG R        | 560Ω 1/16W        | J      |   |
|                 | R1002      | NRSA63J-102X | MG R      | 1kΩ 1/16W   | J     |                 | R1523      | QRJ146J-333X  | C R         | 33kΩ 1/4W         | J      |   |
|                 | R1003-04   | NRSA63J-0R0X | MG R      | 0.0Ω 1/16W  | J     | △               | R1525      | QRZ9011-470   | F R         | 47Ω 1/2W          | J      |   |
|                 | R1011      | NRSA63J-820X | MG R      | 82Ω 1/16W   | J     |                 | R1526      | QRE121J-272Y  | C R         | 2.7kΩ 1/2W        | J      |   |
|                 | R1012      | NRSA63J-182X | MG R      | 1.8kΩ 1/16W | J     |                 | R1527-28   | QRE121J-154Y  | C R         | 150kΩ 1/2W        | J      |   |
|                 | R1013      | NRSA63J-562X | MG R      | 5.6kΩ 1/16W | J     |                 | R1529      | NRSA63J-331X  | MG R        | 330Ω 1/16W        | J      |   |
|                 | R1014      | QRE121J-101Y | C R       | 100Ω 1/2W   | J     | △               | R1531      | QRJ146J-391X  | C R         | 390Ω 1/4W         | J      |   |
|                 | R1015      | NRSA63J-180X | MG R      | 18Ω 1/16W   | J     |                 | R1532      | NRSA63J-273X  | MG R        | 27kΩ 1/16W        | J      |   |
|                 | R1016      | NRSA63J-270X | MG R      | 27Ω 1/16W   | J     |                 | R1533-34   | NRSA63J-123X  | MG R        | 12kΩ 1/16W        | J      |   |
|                 | R1018      | NRSA63J-104X | MG R      | 100kΩ 1/16W | J     | △               | R1535      | NRVA02D-242X  | MF R        | 2.4kΩ 1/10W ±0.5% |        |   |
|                 | R1020      | NRSA63J-332X | MG R      | 3.3kΩ 1/16W | J     | △               | R1537      | NRZ0032-7151X | MF R        | 7.15kΩ            |        |   |
|                 | R1021      | NRSA63J-123X | MG R      | 12kΩ 1/16W  | J     |                 | R1538      | NRSA63J-333X  | MG R        | 33kΩ 1/16W        | J      |   |
|                 | R1022      | NRSA63J-151X | MG R      | 150Ω 1/16W  | J     |                 | R1543      | QRE121J-122Y  | C R         | 1.2kΩ 1/2W        | J      |   |
|                 | R1023      | NRSA63J-101X | MG R      | 100Ω 1/16W  | J     |                 | R1544      | QRE121J-392Y  | C R         | 3.9kΩ 1/2W        | J      |   |
|                 | R1024      | NRSA63J-102X | MG R      | 1kΩ 1/16W   | J     |                 | R1545      | QRE121J-822Y  | C R         | 8.2kΩ 1/2W        | J      |   |
|                 | R1025      | NRSA63J-561X | MG R      | 560Ω 1/16W  | J     |                 | R1546      | NRSA63J-331X  | MG R        | 330Ω 1/16W        | J      |   |
|                 | R1026      | NRSA63J-331X | MG R      | 330Ω 1/16W  | J     |                 | R1547      | NRSA63J-104X  | MG R        | 100kΩ 1/16W       | J      |   |
|                 | R1028      | NRSA63J-821X | MG R      | 820Ω 1/16W  | J     |                 | R1548      | QRE121J-152Y  | C R         | 1.5kΩ 1/2W        | J      |   |
|                 | R1038      | NRSA63J-272X | MG R      | 2.7kΩ 1/16W | J     |                 | R1553      | QRL039J-180   | OM R        | 18Ω 3W            | J      |   |
|                 | R1039-40   | NRSA63J-0R0X | MG R      | 0.0Ω 1/16W  | J     |                 | R1601-03   | NRSA63J-750X  | MG R        | 75Ω 1/16W         | J      |   |
|                 | R1041      | NRSA63J-272X | MG R      | 2.7kΩ 1/16W | J     |                 | R1610-12   | NRSA63J-221X  | MG R        | 220Ω 1/16W        | J      |   |
|                 | R1042-43   | NRSA63J-102X | MG R      | 1kΩ 1/16W   | J     |                 | R1700-02   | NRSA63J-102X  | MG R        | 1kΩ 1/16W         | J      |   |
|                 | R1045-46   | NRSA63J-0R0X | MG R      | 0.0Ω 1/16W  | J     |                 | R1704-05   | NRSA63J-472X  | MG R        | 4.7kΩ 1/16W       | J      |   |
|                 | R1047      | NRSA63J-153X | MG R      | 15kΩ 1/16W  | J     |                 | R1706-07   | NRSA63J-103X  | MG R        | 10kΩ 1/16W        | J      |   |
|                 | R1048      | NRSA63J-154X | MG R      | 150kΩ 1/16W | J     |                 | R1708-09   | NRSA63J-101X  | MG R        | 100Ω 1/16W        | J      |   |
|                 | R1101-02   | NRSA63J-101X | MG R      | 100Ω 1/16W  | J     |                 | R1715      | NRSA63J-103X  | MG R        | 10kΩ 1/16W        | J      |   |
|                 | R1111      | NRSA63J-105X | MG R      | 1MΩ 1/16W   | J     |                 | R1721-22   | NRSA63J-102X  | MG R        | 1kΩ 1/16W         | J      |   |
|                 | R1131      | NRSA63J-272X | MG R      | 2.7kΩ 1/16W | J     |                 | R1724      | NRSA63J-102X  | MG R        | 1kΩ 1/16W         | J      |   |
|                 | R1134      | NRSA63J-562X | MG R      | 5.6kΩ 1/16W | J     |                 | R1726-28   | NRSA63J-102X  | MG R        | 1kΩ 1/16W         | J      |   |
|                 | R1135      | NRSA63J-102X | MG R      | 1kΩ 1/16W   | J     |                 | R1729      | NRSA63J-223X  | MG R        | 22kΩ 1/16W        | J      |   |
|                 | R1140      | NRSA63J-562X | MG R      | 5.6kΩ 1/16W | J     |                 | R1731-32   | NRSA63J-101X  | MG R        | 100Ω 1/16W        | J      |   |
|                 | R1141      | NRSA63J-0R0X | MG R      | 0.0Ω 1/16W  | J     |                 | R1733-34   | NRSA63J-272X  | MG R        | 2.7kΩ 1/16W       | J      |   |
|                 | R1201      | NRSA63J-333X | MG R      | 33kΩ 1/16W  | J     |                 | R1737      | NRSA63J-222X  | MG R        | 2.2kΩ 1/16W       | J      |   |
|                 | R1231      | NRSA63J-182X | MG R      | 1.8kΩ 1/16W | J     |                 | R1738      | NRSA63J-102X  | MG R        | 1kΩ 1/16W         | J      |   |
|                 | R1237      | NRSA63J-392X | MG R      | 3.9kΩ 1/16W | J     |                 | R1739      | NRSA63J-272X  | MG R        | 2.7kΩ 1/16W       | J      |   |
|                 | R1238      | NRSA63J-473X | MG R      | 47kΩ 1/16W  | J     |                 | R1740      | NRSA63J-103X  | MG R        | 10kΩ 1/16W        | J      |   |
|                 | R1241      | NRSA63J-332X | MG R      | 3.3kΩ 1/16W | J     |                 | R1741      | NRSA63J-0R0X  | MG R        | 0.0Ω 1/16W        | J      |   |
|                 | R1243      | NRSA63J-152X | MG R      | 1.5kΩ 1/16W | J     |                 | R1742-43   | NRSA63J-103X  | MG R        | 10kΩ 1/16W        | J      |   |
|                 | R1281      | NRSA63J-182X | MG R      | 1.8kΩ 1/16W | J     |                 | R1748      | NRSA63J-103X  | MG R        | 10kΩ 1/16W        | J      |   |
|                 | R1282      | NRSA63J-392X | MG R      | 3.9kΩ 1/16W | J     |                 | R1749-51   | NRSA63J-222X  | MG R        | 2.2kΩ 1/16W       | J      |   |
|                 | R1283      | NRSA63J-681X | MG R      | 680Ω 1/16W  | J     |                 | R1752      | NRSA63J-102X  | MG R        | 1kΩ 1/16W         | J      |   |
|                 | R1286      | NRSA63J-472X | MG R      | 4.7kΩ 1/16W | J     |                 | R1753      | NRSA63J-0R0X  | MG R        | 0.0Ω 1/16W        | J      |   |
|                 | R1287      | NRSA63J-101X | MG R      | 100Ω 1/16W  | J     |                 | R1754      | NRSA63J-102X  | MG R        | 1kΩ 1/16W         | J      |   |
|                 | R1288      | NRSA02J-471X | MG R      | 470Ω 1/10W  | J     |                 | R1755      | NRSA63J-153X  | MG R        | 15kΩ 1/16W        | J      |   |
|                 | R1289      | NRSA63J-154X | MG R      | 150kΩ 1/16W | J     |                 | R1756      | NRSA63J-103X  | MG R        | 10kΩ 1/16W        | J      |   |
|                 | R1290      | NRSA02J-561X | MG R      | 560Ω 1/10W  | J     |                 | R1764-68   | NRSA63J-221X  | MG R        | 220Ω 1/16W        | J      |   |
|                 | R1291      | NRSA63J-103X | MG R      | 10kΩ 1/16W  | J     |                 | R1769-70   | NRSA63J-682X  | MG R        | 6.8kΩ 1/16W       | J      |   |
|                 | R1292      | NRSA63J-123X | MG R      | 12kΩ 1/16W  | J     |                 | R1772      | NRSA63J-103X  | MG R        | 10kΩ 1/16W        | J      |   |
|                 | R1301-03   | NRSA63J-222X | MG R      | 2.2kΩ 1/16W | J     |                 | R1774      | NRSA63J-682X  | MG R        | 6.8kΩ 1/16W       | J      |   |
|                 | R1304-06   | NRSA63J-101X | MG R      | 100Ω 1/16W  | J     |                 | R1775      | NRSA63J-473X  | MG R        | 47kΩ 1/16W        | J      |   |
|                 | R1354-55   | NRSA63J-0R0X | MG R      | 0.0Ω 1/16W  | J     |                 | R1776      | NRSA63J-272X  | MG R        | 2.7kΩ 1/16W       | J      |   |
|                 | R1356      | NRSA63J-123X | MG R      | 12kΩ 1/16W  | J     |                 | R1777      | NRSA63J-103X  | MG R        | 10kΩ 1/16W        | J      |   |
|                 | R1359      | NRSA63J-103X | MG R      | 10kΩ 1/16W  | J     |                 | R1793-95   | NRSA63J-331X  | MG R        | 330Ω 1/16W        | J      |   |
|                 | R1360      | NRSA63J-0R0X | MG R      | 0.0Ω 1/16W  | J     |                 | R1798-99   | NRSA63J-103X  | MG R        | 10kΩ 1/16W        | J      |   |
|                 | R1401      | NRSA63J-822X | MG R      | 8.2kΩ 1/16W | J     |                 | R1800      | NRSA63J-103X  | MG R        | 10kΩ 1/16W        | J      |   |
|                 | R1403      | QRX01GJ-1R0  | MF R      | 1.0Ω 1W     | J     |                 | R1801-04   | NRSA63J-0R0X  | MG R        | 0.0Ω 1/16W        | J      |   |
|                 | R1404      | QRE121J-100Y | C R       | 10Ω 1/2W    | J     |                 | R1806      | NRSA63J-102X  | MG R        | 1kΩ 1/16W         | J      |   |
|                 | R1405      | NRSA63J-103X | MG R      | 10kΩ 1/16W  | J     |                 | R1807      | NRSA63J-222X  | MG R        | 2.2kΩ 1/16W       | J      |   |
|                 | R1407      | NRSA02J-0R0X | MG R      | 0.0Ω 1/10W  | J     |                 | R1810      | NRSA63J-0R0X  | MG R        | 0.0Ω 1/16W        | J      |   |
|                 | R1411-12   | NRSA63J-103X | MG R      | 10kΩ 1/16W  | J     |                 | R1811      | NRSA63J-473X  | MG R        | 47kΩ 1/16W        | J      |   |
|                 | R1414      | QRL029J-221  | OM R      | 220Ω 2W     | J     |                 | R1812      | NRSA63J-102X  | MG R        | 1kΩ 1/16W         | J      |   |
|                 | R1431      | QRE121J-272Y | C R       | 2.7kΩ 1/2W  | J     |                 | R1814      | NRSA63J-104X  | MG R        | 100kΩ 1/16W       | J      |   |
|                 | R1432      | NRSA63J-104X | MG R      | 100kΩ 1/16W | J     |                 | R1815      | NRSA63J-154X  | MG R        | 150kΩ 1/16W       | J      |   |
|                 | R1433      | NRSA63J-473X | MG R      | 47kΩ 1/16W  | J     |                 | R1816      | NRSA63J-0R0X  | MG R        | 0.0Ω 1/16W        | J      |   |
|                 | R1434      | NRSA63J-822X | MG R      | 8.2kΩ 1/16W | J     |                 | R1817      | NRSA63J-104X  | MG R        | 100kΩ 1/16W       | J      |   |
|                 | R1435      | NRSA63J-103X | MG R      | 10kΩ 1/16W  | J     |                 | R1818      | NRSA63J-0R0X  | MG R        | 0.0Ω 1/16W        | J      |   |
|                 | R1501      | NRSA63J-0R0X | MG R      | 0.0Ω 1/16W  | J     |                 | R1821      | NRSA63J-104X  | MG R        | 100kΩ 1/16W       | J      |   |
|                 | R1502      | NRSA63J-271X | MG R      | 270Ω 1/16W  | J     |                 | R1824      | NRSA63J-103X  | MG R        | 10kΩ 1/16W        | J      |   |
|                 | R1503      | QRE121J-103Y | C R       | 10kΩ 1/2W   | J     |                 | R1827      | NRSA63J-102X  | MG R        | 1kΩ 1/16W         | J      |   |
|                 | R1504-05   | QRL039J-152  | OM R      | 1.5kΩ 3W    | J     |                 | △          | R1857         | QRG029J-330 | OM R              | 33Ω 2W | J |
|                 | R1511      | QRE121J-220Y | C R       | 22Ω 1/2W    | J     |                 | △          | R1858         | QRG029J-180 | OM R              | 18Ω 2W | J |
|                 | R1512      | QRE121J-681Y | C R       | 680Ω 1/2W   | J     |                 | R1860      | NRSA63J-562X  | MG R        | 5.6kΩ 1/16W       | J      |   |

| △                | Symbol No. | Part No.     | Part Name | Description | Local | △                | Symbol No. | Part No.     | Part Name   | Description | Local   |            |   |
|------------------|------------|--------------|-----------|-------------|-------|------------------|------------|--------------|-------------|-------------|---------|------------|---|
| <b>RESISTOR</b>  |            |              |           |             |       | <b>CAPACITOR</b> |            |              |             |             |         |            |   |
| △                | R1901      | QRF074K-R47  | UNF R     | 0.47Ω       | 7W    | K                | C1288      | NCB31HK-103X | C CAP.      | 0.01μF      | 50V     | K          |   |
| △                | R1909      | QRG01GJ-470  | OM R      | 47Ω         | 1W    | J                | C1352      | QETN1CM-336Z | E CAP.      | 33μF        | 16V     | M          |   |
|                  | R1911      | QRE121J-223Y | C R       | 22kΩ        | 1/2W  | J                | C1354      | QFV71HJ-154Z | MF CAP.     | 0.15μF      | 50V     | J          |   |
|                  | R1912-13   | QRT029J-R22  | MF R      | 0.22Ω       | 2W    | J                | C1391      | QETN1CM-107Z | E CAP.      | 100μF       | 16V     | M          |   |
|                  | R1914      | QRK126J-681X | C R       | 680Ω        | 1/2W  | J                | C1392      | NCB31HK-103X | C CAP.      | 0.01μF      | 50V     | K          |   |
|                  | R1915      | QRE121J-270Y | C R       | 27Ω         | 1/2W  | J                | C1393-95   | NCB21HK-104X | C CAP.      | 0.1μF       | 50V     | K          |   |
|                  | R1917      | QRK126J-332X | C R       | 3.3kΩ       | 1/2W  | J                | C1401      | NDC21HJ-152X | C CAP.      | 1500pF      | 50V     | J          |   |
|                  | R1918      | QRE121J-222Y | C R       | 2.2kΩ       | 1/2W  | J                | C1403      | NCB21HK-273X | C CAP.      | 0.027μF     | 50V     | K          |   |
|                  | R1919      | QRE121J-684Y | C R       | 680kΩ       | 1/2W  | J                | C1404      | QETN1VM-107Z | E CAP.      | 100μF       | 35V     | M          |   |
|                  | R1924      | QRE121J-222Y | C R       | 2.2kΩ       | 1/2W  | J                | C1405      | QCS32HJ-100Z | C CAP.      | 10pF        | 500V    | J          |   |
|                  | R1930      | QRE121J-223Y | C R       | 22kΩ        | 1/2W  | J                | C1407      | QFLC2AK-563Z | M CAP.      | 0.056μF     | 100V    | K          |   |
|                  | R1939      | QRT039J-R22  | MF R      | 2.2Ω        | 3W    | J                | C1410      | QFLC2AJ-104Z | M CAP.      | 0.1μF       | 100V    | J          |   |
|                  | R1940      | QRE121J-181Y | C R       | 180Ω        | 1/2W  | J                | C1411      | QETN1HM-105Z | E CAP.      | 1μF         | 50V     | M          |   |
|                  | R1941      | QRL029J-183  | OM R      | 18kΩ        | 2W    | J                | C1415      | NCB21HK-104X | C CAP.      | 0.1μF       | 50V     | K          |   |
|                  | R1943      | NRSA63J-104X | MG R      | 100kΩ       | 1/16W | J                | C1421      | QEHQ1VM-108  | E CAP.      | 1000μF      | 35V     | M          |   |
|                  | R1944      | NRSA63J-122X | MG R      | 1.2kΩ       | 1/16W | J                | C1431      | QETN1HM-105Z | E CAP.      | 1μF         | 50V     | M          |   |
|                  | R1951      | NRSA63J-473X | MG R      | 47kΩ        | 1/16W | J                | C1432      | QETN1EM-476Z | E CAP.      | 47μF        | 25V     | M          |   |
|                  | R1952      | NRSA63J-102X | MG R      | 1kΩ         | 1/16W | J                | C1501      | QCB32HK-151Z | C CAP.      | 150pF       | 500V    | K          |   |
|                  | R1953      | QRE121J-151Y | C R       | 150Ω        | 1/2W  | J                | C1502      | QCB32HK-331Z | C CAP.      | 330pF       | 500V    | K          |   |
|                  | R1973      | QRE121J-272Y | C R       | 2.7kΩ       | 1/2W  | J                | C1503      | QEHR2CM-105Z | E CAP.      | 1μF         | 160V    | M          |   |
|                  | R1975      | QRE121J-223Y | C R       | 22kΩ        | 1/2W  | J                | C1504      | QEZ0203-107  | E CAP.      | 100μF       | 160V    | M          |   |
|                  | R1977      | QRE121J-473Y | C R       | 47kΩ        | 1/2W  | J                | C1507-08   | QEM61HK-475Z | E CAP.      | 4.7μF       | 50V     | K          |   |
|                  | R1978      | NRSA63J-333X | MG R      | 33kΩ        | 1/16W | J                | △          | C1510        | QFZ0196-502 | MPP CAP.    | 5000pF  | 1.5kVH ±3% |   |
|                  | R1979-80   | QRT029J-1R2  | MF R      | 1.2Ω        | 2W    | J                | △          | C1513        | QFZ0198-133 | MPP CAP.    | 0.013μF | 1.5kVH ±3% |   |
| <b>CAPACITOR</b> |            |              |           |             |       |                  | △          | C1514        | QFP32GJ-183 | PP CAP.     | 0.018μF | 400V       | J |
|                  | C1001      | QETN1HM-475Z | E CAP.    | 4.7μF       | 50V   | M                | △          | C1515        | QFZ0197-564 | MPP CAP.    | 0.56μF  | 250V       | J |
|                  | C1002      | QETN1HM-106Z | E CAP.    | 10μF        | 50V   | M                | C1516      | QCB32HK-561Z | C CAP.      | 560pF       | 500V    | K          |   |
|                  | C1003      | QETN1CM-108Z | E CAP.    | 1000μF      | 16V   | M                | C1521      | QETN2EM-106Z | E CAP.      | 10μF        | 250V    | M          |   |
|                  | C1011-12   | NCB31HK-103X | C CAP.    | 0.01μF      | 50V   | K                | C1523      | QEHR1EM-108Z | E CAP.      | 1000μF      | 25V     | M          |   |
|                  | C1014      | QETN1CM-107Z | E CAP.    | 100μF       | 16V   | M                | C1524      | QETN1EM-108Z | E CAP.      | 1000μF      | 25V     | M          |   |
|                  | C1015-16   | NCB31HK-103X | C CAP.    | 0.01μF      | 50V   | K                | C1525      | QETN1VM-107Z | E CAP.      | 100μF       | 35V     | M          |   |
|                  | C1021      | QFV71HJ-824Z | MF CAP.   | 0.82μF      | 50V   | J                | C1526      | QFV21HJ-824Z | MF CAP.     | 0.82μF      | 50V     | J          |   |
|                  | C1023      | QETN1CM-107Z | E CAP.    | 100μF       | 16V   | M                |            |              |             |             |         |            |   |
|                  | C1024      | NCB31HK-103X | C CAP.    | 0.01μF      | 50V   | K                | C1527      | QFLC2AJ-103Z | M CAP.      | 0.01μF      | 100V    | J          |   |
|                  | C1025      | NCB31HK-102X | C CAP.    | 1000pF      | 50V   | K                | C1531      | QCB32HK-102Z | C CAP.      | 1000pF      | 500V    | K          |   |
|                  | C1026      | QETN1HM-474Z | E CAP.    | 0.47μF      | 50V   | M                | C1533      | QETN1HM-106Z | E CAP.      | 10μF        | 50V     | M          |   |
|                  | C1027      | NCB21HK-104X | C CAP.    | 0.1μF       | 50V   | K                | C1601-03   | QETN1EM-476Z | E CAP.      | 47μF        | 25V     | M          |   |
|                  | C1028      | QETN1HM-106Z | E CAP.    | 10μF        | 50V   | M                | C1609-11   | QFV71HJ-104Z | MF CAP.     | 0.1μF       | 50V     | J          |   |
|                  | C1030      | NCB31HK-103X | C CAP.    | 0.01μF      | 50V   | K                | C1612      | QETN1HM-105Z | E CAP.      | 1μF         | 50V     | M          |   |
|                  | C1034      | NCB31HK-103X | C CAP.    | 0.01μF      | 50V   | K                | C1700      | NCB31HK-102X | C CAP.      | 1000pF      | 50V     | K          |   |
|                  | C1036      | QETN1AM-477Z | E CAP.    | 470μF       | 10V   | M                | C1703      | NDC31HJ-181X | C CAP.      | 180pF       | 50V     | J          |   |
|                  | C1037      | NCB31HK-103X | C CAP.    | 0.01μF      | 50V   | K                | C1706      | QETN1HM-105Z | E CAP.      | 1μF         | 50V     | M          |   |
|                  | C1038      | QETN1CM-107Z | E CAP.    | 100μF       | 16V   | M                | C1707      | QETN1CM-107Z | E CAP.      | 100μF       | 16V     | M          |   |
|                  | C1041-42   | QETN1HM-106Z | E CAP.    | 10μF        | 50V   | M                | C1710      | NCB21EK-683X | C CAP.      | 0.068μF     | 25V     | K          |   |
|                  | C1043-44   | NDC31HJ-470X | C CAP.    | 47pF        | 50V   | J                | C1721      | NCB31HK-103X | C CAP.      | 0.01μF      | 50V     | K          |   |
|                  | C1045      | QETN1HM-106Z | E CAP.    | 10μF        | 50V   | M                | C1722-23   | NDC31HJ-390X | C CAP.      | 39pF        | 50V     | J          |   |
|                  | C1046      | NCB31HK-103X | C CAP.    | 0.01μF      | 50V   | K                | C1724      | NDC31HJ-471X | C CAP.      | 470pF       | 50V     | J          |   |
|                  | C1047      | NDC21HJ-330X | C CAP.    | 33pF        | 50V   | J                | C1726      | NDC21HJ-561X | C CAP.      | 560pF       | 50V     | J          |   |
|                  | C1048      | NCB31HK-103X | C CAP.    | 0.01μF      | 50V   | K                | C1800      | QETN1CM-107Z | E CAP.      | 100μF       | 16V     | M          |   |
|                  | C1111      | QETN0JM-228Z | E CAP.    | 2200μF      | 6.3V  | M                | C1801      | NCB21HK-104X | C CAP.      | 0.1μF       | 50V     | K          |   |
|                  | C1112      | NCB31HK-103X | C CAP.    | 0.01μF      | 50V   | K                | C1802      | QETN1CM-107Z | E CAP.      | 100μF       | 16V     | M          |   |
|                  | C1113      | QETN1HM-474Z | E CAP.    | 0.47μF      | 50V   | M                | C1803      | QETN1HM-106Z | E CAP.      | 10μF        | 50V     | M          |   |
|                  | C1114      | QETN1HM-105Z | E CAP.    | 1μF         | 50V   | M                | C1804      | NDC31HJ-102X | C CAP.      | 1000pF      | 50V     | K          |   |
|                  | C1115      | QFV71HJ-104Z | MF CAP.   | 0.1μF       | 50V   | J                | C1805      | NCB31HK-153X | C CAP.      | 0.015μF     | 50V     | K          |   |
|                  | C1116      | NCB21HK-104X | C CAP.    | 0.1μF       | 50V   | K                | C1806-07   | QETN1HM-106Z | E CAP.      | 10μF        | 50V     | M          |   |
|                  | C1131      | NDC31HJ-470X | C CAP.    | 47pF        | 50V   | J                | C1810      | QETN1HM-474Z | E CAP.      | 0.47μF      | 50V     | M          |   |
|                  | C1136      | QENC1CM-106Z | BP E CAP. | 10μF        | 16V   | M                | C1811      | QETN1HM-105Z | E CAP.      | 1μF         | 50V     | M          |   |
|                  | C1151      | NCB31HK-103X | C CAP.    | 0.01μF      | 50V   | K                | C1813      | NCB31HK-102X | C CAP.      | 1000pF      | 50V     | K          |   |
|                  | C1152      | QENC1HM-105Z | BP E CAP. | 1μF         | 50V   | M                | C1816      | NCB31HK-153X | C CAP.      | 0.015μF     | 50V     | K          |   |
|                  | C1201      | NDC31HJ-100X | C CAP.    | 10pF        | 50V   | J                | C1853-54   | QETN1CM-227Z | E CAP.      | 220μF       | 16V     | M          |   |
|                  | C1202      | QETN1HM-224Z | E CAP.    | 0.22μF      | 50V   | M                | C1856      | QETN1CM-227Z | E CAP.      | 220μF       | 16V     | M          |   |
|                  | C1203      | NCB31HK-222X | C CAP.    | 2200pF      | 50V   | K                | C1857      | QETN1CM-477Z | E CAP.      | 470μF       | 16V     | M          |   |
|                  | C1233      | NDC31HJ-560X | C CAP.    | 56pF        | 50V   | J                | △          | C1904-06     | QCZ9054-102 | C CAP.      | 1000pF  | 250V       | Z |
|                  | C1237      | NCB31HK-103X | C CAP.    | 0.01μF      | 50V   | K                | △          | C1907        | QEZ0169-477 | E CAP.      | 470μF   | 200V       | M |
|                  | C1281      | QFV71HJ-474Z | MF CAP.   | 0.47μF      | 50V   | J                | △          | C1908        | QCZ9054-102 | C CAP.      | 1000pF  | 250V       | Z |
|                  | C1282      | QETN1CM-227Z | E CAP.    | 220μF       | 16V   | M                | C1912      | QCZ0340-222  | C CAP.      | 2200pF      | 50V     | J          |   |
|                  | C1283      | NCB31HK-103X | C CAP.    | 0.01μF      | 50V   | K                | C1913      | QFLC1HJ-471Z | M CAP.      | 470pF       | 50V     | J          |   |
|                  | C1284      | QETN1HM-225Z | E CAP.    | 2.2μF       | 50V   | M                | C1914      | QETN1HM-107Z | E CAP.      | 100μF       | 50V     | M          |   |
|                  | C1285      | NCB31HK-103X | C CAP.    | 0.01μF      | 50V   | K                | C1916      | NDC31HJ-331X | C CAP.      | 330pF       | 50V     | J          |   |
|                  | C1286      | QETN1HM-106Z | E CAP.    | 10μF        | 50V   | M                | C1917      | NCB21HK-122X | C CAP.      | 1200pF      | 50V     | K          |   |
|                  | C1287      | QETN1CM-107Z | E CAP.    | 100μF       | 16V   | M                | C1918      | NCB21HK-104X | C CAP.      | 0.1μF       | 50V     | K          |   |
|                  |            |              |           |             |       |                  | C1919      | QFP32GJ-103  | PP CAP.     | 0.01μF      | 400V    | J          |   |
|                  |            |              |           |             |       |                  | C1925      | NRSA63J-0R0X | MG R        | 0.0Ω        | 1/16W   | J          |   |

| △ Symbol No.     | Part No.     | Part Name | Description | Local |
|------------------|--------------|-----------|-------------|-------|
| <b>CAPACITOR</b> |              |           |             |       |
| C1931            | QEZ0203-107  | E CAP.    | 100μF 160V  | M     |
| C1932            | QETN1CM-108Z | E CAP.    | 1000μF 16V  | M     |
| C1933            | QETM1EM-228  | E CAP.    | 2200μF 25V  | M     |
| C1935            | QETN1EM-108Z | E CAP.    | 1000μF 25V  | M     |
| C1937            | QCZ0340-102  | C CAP.    | 1000pF      |       |
| C1938            | QETM1EM-228  | E CAP.    | 2200μF 25V  | M     |
| C1939            | QCB32HK-152Z | C CAP.    | 1500pF 500V | K     |
| C1941            | QCB32HK-102Z | C CAP.    | 1000pF 500V | K     |
| C1942            | QEHR1HM-105Z | E CAP.    | 1μF 50V     | M     |
| C1943            | QETN1CM-108Z | E CAP.    | 1000μF 16V  | M     |
| C1948            | QETN1EM-476Z | E CAP.    | 47μF 25V    | M     |
| C1951            | QETN1CM-477Z | E CAP.    | 470μF 16V   | M     |
| C1971            | QETN1CM-107Z | E CAP.    | 100μF 16V   | M     |
| C1972            | QETN1EM-476Z | E CAP.    | 47μF 25V    | M     |
| C1973            | QETN1HM-106Z | E CAP.    | 10μF 50V    | M     |
| △ C1998-99       | QCZ9074-103  | C CAP.    | 0.01μF 125V | M     |

|                    |             |                 |  |  |
|--------------------|-------------|-----------------|--|--|
| <b>TRANSFORMER</b> |             |                 |  |  |
| T1501              | CE42034-002 | H.DRIVE TRANSF. |  |  |
| △ T1502            | QQH0092-001 | H.V.TRANSF.     |  |  |
| △ T1921            | QQS0098-001 | SWITCH.TRANSF.  |  |  |
| △ T1951            | QQT0315-001 | POWER TRANSF.   |  |  |

|             |              |              |        |        |
|-------------|--------------|--------------|--------|--------|
| <b>COIL</b> |              |              |        |        |
| △ L1001     | QQL244K-560Z | PEAKING COIL | 56μH   | K      |
| L1012       | QQLZ014-R39  | PEAKING COIL | 0.39μH |        |
| L1021       | QRN143J-0R0X | C R          | 0.0Ω   | 1/4W J |
| L1022       | QQL244K-220Z | PEAKING COIL | 22μH   | K      |
| L1027       | QRN143J-0R0X | C R          | 0.0Ω   | 1/4W J |
| L1041       | QRN143J-0R0X | C R          | 0.0Ω   | 1/4W J |
| L1042       | QQL244K-220Z | PEAKING COIL | 22μH   | K      |
| L1101       | QQL244K-470Z | COIL         | 47μH   | K      |
| L1232       | QQL244K-560Z | PEAKING COIL | 56μH   | K      |
| △ L1511     | QQR1027-003  | LINE FILTER  |        |        |
| L1512       | QQLZ027-821  | CHOKE COIL   | 820μH  |        |
| △ L1521     | QQLZ026-430  | HEATER CHOKE | 43μH   |        |
| L1700       | QQL244K-4R7Z | COIL         | 4.7μH  | K      |
| L1810       | QQL244J-100Z | COIL         | 10μH   | J      |
| L1931       | QQL26AK-470Z | COIL         | 47μH   | K      |
| L1933       | QQL26AK-470Z | COIL         | 47μH   | K      |
| L1937       | QQL26AK-470Z | COIL         | 47μH   | K      |

|              |                |             |  |  |
|--------------|----------------|-------------|--|--|
| <b>DIODE</b> |                |             |  |  |
| D1101-02     | MTZJ8.2C-T2    | ZENER DIODE |  |  |
| D1305        | 1SS133-T2      | SI.DIODE    |  |  |
| D1306        | 1SS133-T2      | SI.DIODE    |  |  |
| D1307        | 1SS133-T2      | SI.DIODE    |  |  |
| D1308        | 1SS133-T2      | SI.DIODE    |  |  |
| D1309        | 1SS133-T2      | SI.DIODE    |  |  |
| D1310        | 1SS133-T2      | SI.DIODE    |  |  |
| D1352        | MTZJ9.1C-T2    | ZENER DIODE |  |  |
| D1353        | 1SS133-T2      | SI.DIODE    |  |  |
| D1401        | 1SR35-400A-T2  | SI.DIODE    |  |  |
| D1431        | 1SR35-400A-T2  | SI.DIODE    |  |  |
| D1432        | 1SS133-T2      | SI.DIODE    |  |  |
| D1501        | RH3G-F1        | SI.DIODE    |  |  |
| D1502        | RU3AM-LFC4     | SI.DIODE    |  |  |
| D1521        | RH1S-T3        | SI.DIODE    |  |  |
| D1523-24     | RGP10J-5025-T3 | SI.DIODE    |  |  |
| D1525-26     | 1SS81-T5       | SI.DIODE    |  |  |
| D1527        | 1SR124-400A-T2 | SI.DIODE    |  |  |
| D1529        | MTZJ5.1C-T2    | ZENER DIODE |  |  |
| △ D1531      | MA4068N/Z1-T2  | ZENER DIODE |  |  |
| D1535        | 1SS133-T2      | SI.DIODE    |  |  |
| D1537        | 1SR35-400A-T2  | SI.DIODE    |  |  |
| D1601        | MTZJ9.1C-T2    | ZENER DIODE |  |  |
| D1603        | MTZJ9.1C-T2    | ZENER DIODE |  |  |
| D1606        | MTZJ9.1C-T2    | ZENER DIODE |  |  |
| D1701        | 1SS133-T2      | SI.DIODE    |  |  |

| △ Symbol No. | Part No.       | Part Name    | Description | Local |
|--------------|----------------|--------------|-------------|-------|
| <b>DIODE</b> |                |              |             |       |
| D1706-10     | MTZJ8.2C-T2    | ZENER DIODE  |             |       |
| D1721        | 1SS133-T2      | SI.DIODE     |             |       |
| D1722        | 1SS133-T2      | SI.DIODE     |             |       |
| D1723-24     | MTZJ5.6B-T2    | ZENER DIODE  |             |       |
| D1800        | 1SS81-T2       | SI.DIODE     |             |       |
| D1801        | 1SS133-T2      | SI.DIODE     |             |       |
| D1810        | MTZJ8.2C-T2    | ZENER DIODE  |             |       |
| D1811        | 1SS133-T2      | SI.DIODE     |             |       |
| △ D1901      | D3SBA60        | DIODE BRIDGE |             |       |
| D1910        | MA700A-T2      | SI.DIODE     |             |       |
| △ D1911-13   | RGP10J-5025-T3 | SI.DIODE     |             |       |
| D1914        | 1SS133-T2      | SI.DIODE     |             |       |
| D1915        | SARS01-T2      | SI.DIODE     |             |       |
| D1917        | MTZJ30A-T2     | ZENER DIODE  |             |       |
| D1918        | MTZJ5.1C-T2    | ZENER DIODE  |             |       |
| D1920        | 1SS133-T2      | SI.DIODE     |             |       |
| D1931        | RU30A-F1       | SI.DIODE     |             |       |
| D1933        | RU3YX-LFC4     | SI.DIODE     |             |       |
| D1935        | RU3YX-LFC4     | SI.DIODE     |             |       |
| D1937        | RGP10J-5025-T3 | SI.DIODE     |             |       |
| D1941        | MTZJ33A-T2     | ZENER DIODE  |             |       |
| D1945        | 1SS133-T2      | SI.DIODE     |             |       |
| D1952        | 1SS133-T2      | SI.DIODE     |             |       |
| D1953        | 1SS133-T2      | SI.DIODE     |             |       |
| D1954-57     | 1SR35-400A-T2  | SI.DIODE     |             |       |
| D1972        | MTZJ15C-T2     | ZENER DIODE  |             |       |
| D1973        | 1SS133-T2      | SI.DIODE     |             |       |

|                   |                 |                 |  |  |
|-------------------|-----------------|-----------------|--|--|
| <b>TRANSISTOR</b> |                 |                 |  |  |
| Q1011             | 2SC5083/L-P/T   | SI.TRANSISTOR   |  |  |
| Q1021             | 2SC2412K/QR/-X  | SI.TRANSISTOR   |  |  |
| Q1024             | 2SC2412K/QR/-X  | SI.TRANSISTOR   |  |  |
| Q1025             | 2SA1037AK/QR/-X | SI.TRANSISTOR   |  |  |
| Q1041             | 2SA1037AK/QR/-X | SI.TRANSISTOR   |  |  |
| Q1131             | 2SC2412K/QR/-X  | SI.TRANSISTOR   |  |  |
| Q1232-33          | 2SC2412K/QR/-X  | SI.TRANSISTOR   |  |  |
| Q1352             | 2SC2412K/QR/-X  | SI.TRANSISTOR   |  |  |
| Q1431             | 2SC2412K/QR/-X  | SI.TRANSISTOR   |  |  |
| Q1501             | 2SC4212/Z1/     | SI.TRANSISTOR   |  |  |
| △ Q1511           | 2SD2559-LB      | SI.TRANSISTOR   |  |  |
| Q1531             | 2SC2785/JH/-T   | SI.TRANSISTOR   |  |  |
| Q1532             | 2SA1037AK/QR/-X | SI.TRANSISTOR   |  |  |
| Q1541-42          | 2SA1037AK/QR/-X | SI.TRANSISTOR   |  |  |
| △ Q1543           | 2SD1408/OY/-LB  | SI.TRANSISTOR   |  |  |
| Q1700             | 2SC2412K/QR/-X  | SI.TRANSISTOR   |  |  |
| Q1701             | 2SA1037AK/QR/-X | SI.TRANSISTOR   |  |  |
| Q1703             | 2SA1037AK/QR/-X | SI.TRANSISTOR   |  |  |
| Q1706             | 2SC2412K/QR/-X  | SI.TRANSISTOR   |  |  |
| Q1711             | DTC124EKA-X     | DIGI.TRANSISTOR |  |  |
| Q1810             | DTC144EKA-X     | DIGI.TRANSISTOR |  |  |
| Q1941             | 2SC2412K/QR/-X  | SI.TRANSISTOR   |  |  |
| Q1951             | 2SD1383K/AB/-X  | SI.TRANSISTOR   |  |  |
| Q1971             | 2SA1208/ST/Z1-T | SI.TRANSISTOR   |  |  |

|           |                |                  |           |  |
|-----------|----------------|------------------|-----------|--|
| <b>IC</b> |                |                  |           |  |
| IC1101    | TB1253AN       | I.C.(M)          |           |  |
| △ IC1401  | LA7841         | I.C.(MONO-ANA)   |           |  |
| IC1701    | MN1876478JL1   | I.C.(MICRO-COMP) |           |  |
| IC1702    | AT24C04-32D502 | I.C.(MEMORY-OTH) | (SERVICE) |  |
| IC1703    | MM1437AF-X     | I.C.(MONO-ANA)   |           |  |
| IC1852    | AN7809F        | I.C.(MONO-ANA)   |           |  |
| IC1853    | AN7805F        | I.C.(MONO-ANA)   |           |  |
| IC1911    | STR-G6624/F8   | I.C.(HYBRID)     |           |  |
| △ IC1921  | SE135N         | I.C.(HYBRID)     |           |  |

|               |              |                |  |  |
|---------------|--------------|----------------|--|--|
| <b>OTHERS</b> |              |                |  |  |
| CF1001        | QAX0349-001  | CERAMIC FILTER |  |  |
| CF1021        | QAX0639-001Z | CERAMIC FILTER |  |  |
| CF1041        | QAX0642-001Z | CERAMIC FILTER |  |  |

## FRONT CONTROL PW BOARD ASS'Y (SAC-8506A-M2)

| △ Symbol No.  | Part No.        | Part Name        | Description | Local |
|---------------|-----------------|------------------|-------------|-------|
| <b>OTHERS</b> |                 |                  |             |       |
| △ CP1932-33   | ICP-N75-Y       | I.C.PROTECT      |             |       |
| △ CP1936      | ICP-N75-Y       | I.C.PROTECT      |             |       |
| △ F1905       | QMFZ034-5R0Z-J1 | FUSE             | 5A          |       |
| △ FR1521      | QRK126J-150X    | C R              | 15Ω 1/2W    | J     |
| △ FR1523-24   | QRX029J-3R3     | MF R             | 3.3Ω 2W     | J     |
| △ FR1525      | QRZ9017-4R7     | F R              | 4.7Ω 1/4W   | J     |
| △ J1601       | QNN0349-002     | PIN JACK         |             |       |
| J1810         | QNS0001-001     | JACK             |             |       |
| K1401         | QQR0621-002Z    | BEADS CORE       |             |       |
| K1912         | QQR0582-001Z    | BEADS CORE       |             |       |
| K1916-17      | QQR0582-001Z    | BEADS CORE       |             |       |
| K1931-33      | QQR0582-001Z    | BEADS CORE       |             |       |
| K1935         | QQR0582-001Z    | BEADS CORE       |             |       |
| K1937         | QQR0582-001Z    | BEADS CORE       |             |       |
| K1940         | QQR0582-001Z    | BEADS CORE       |             |       |
| K1941         | QQR0621-002Z    | BEADS CORE       |             |       |
| LC1601-03     | NQR0169-001X    | EMI FILTER       |             |       |
| △ PC1921      | TLP421F/D4-GR/  | I.C.(PH.COUPLER) |             |       |
| △ RY1941      | QSK0120-001     | RELAY            |             |       |
| △ RY1951      | QSK0113-001     | RELAY            |             |       |
| SF1011        | QAX0324-002     | SAW FILTER       |             |       |
| △ TH1901      | QADD0129-3R0    | P.THERMISTOR     |             |       |
| △ TU1001      | QAU0176-001     | TUNER            |             |       |
| X1201         | CE40668-001Z    | CRYSTAL          |             |       |
| X1700         | QAX0307-001     | CER.RESONATOR    |             |       |

## CRT SOCKET PW BOARD ASS'Y (SAC-3505A-M2)

| △ Symbol No.      | Part No.      | Part Name     | Description  | Local |
|-------------------|---------------|---------------|--------------|-------|
| <b>RESISTOR</b>   |               |               |              |       |
| R3354-56          | NRSA63J-221X  | MG R          | 220Ω 1/16W   | J     |
| R3357-59          | NRSA63J-101X  | MG R          | 100Ω 1/16W   | J     |
| R3360-62          | QRZ0111-152   | C R           | 1.5kΩ 1/2W   | K     |
| R3363-65          | QRG029J-103   | OM R          | 10kΩ 2W      | J     |
| R3366-68          | NRSA63J-182X  | MG R          | 1.8kΩ 1/16W  | J     |
| R3372-74          | NRSA63J-221X  | MG R          | 220Ω 1/16W   | J     |
| R3375-77          | NRSA63J-0R0X  | MG R          | 0.0Ω 1/16W   | J     |
| R3381             | QRE121J-394Y  | C R           | 390kΩ 1/2W   | J     |
| R3391             | NRSA63J-152X  | MG R          | 1.5kΩ 1/16W  | J     |
| R3392             | NRSA63J-392X  | MG R          | 3.9kΩ 1/16W  | J     |
| R3393-95          | NRSA63J-102X  | MG R          | 1kΩ 1/16W    | J     |
| <b>CAPACITOR</b>  |               |               |              |       |
| C3354-55          | NDC31HJ-331X  | C CAP.        | 330pF 50V    | J     |
| C3356             | NDC31HJ-391X  | C CAP.        | 390pF 50V    | J     |
| C3357             | QETN1CM-107Z  | E CAP.        | 100μF 16V    | M     |
| C3382             | QCZ0121-102   | C CAP.        | 1000pF 3000V | Z     |
| C3391             | QETN1AM-227Z  | E CAP.        | 220μF 10V    | M     |
| C3392             | NDC31HJ-101X  | C CAP.        | 100pF 50V    | J     |
| <b>COIL</b>       |               |               |              |       |
| L3381             | QQL244K-101Z  | PEAKING COIL  | 100μH        | K     |
| <b>DIODE</b>      |               |               |              |       |
| D3391             | 1SS133-T2     | SI.DIODE      |              |       |
| <b>TRANSISTOR</b> |               |               |              |       |
| Q3351-53          | 2SC4544-LB    | SI.TRANSISTOR |              |       |
| Q3391             | 2SA933AS/QR-T | SI.TRANSISTOR |              |       |
| <b>OTHERS</b>     |               |               |              |       |
| △ SK3351          | QNZ0464-001   | C.R.T.SOCKET  |              |       |

| △ Symbol No.    | Part No.     | Part Name | Description | Local |
|-----------------|--------------|-----------|-------------|-------|
| <b>RESISTOR</b> |              |           |             |       |
| R8702           | NRSA63J-472X | MG R      | 4.7kΩ 1/16W | J     |
| R8703           | NRSA63J-153X | MG R      | 15kΩ 1/16W  | J     |
| R8705           | NRSA63J-472X | MG R      | 4.7kΩ 1/16W | J     |
| R8706           | NRSA63J-153X | MG R      | 15kΩ 1/16W  | J     |
| R8707           | NRSA63J-222X | MG R      | 2.2kΩ 1/16W | J     |
| R8708           | NRSA63J-681X | MG R      | 680Ω 1/16W  | J     |
| R8709           | NRSA63J-561X | MG R      | 560Ω 1/16W  | J     |

**CAPACITOR**

|       |              |        |          |   |
|-------|--------------|--------|----------|---|
| C8701 | QETN1EM-476Z | E CAP. | 47μF 25V | M |
|-------|--------------|--------|----------|---|

**DIODE**

|       |        |             |  |  |
|-------|--------|-------------|--|--|
| D8701 | GL2PR6 | L.E.D.(RED) |  |  |
|-------|--------|-------------|--|--|

**TRANSISTOR**

|          |             |                 |  |  |
|----------|-------------|-----------------|--|--|
| Q8701-02 | DTA124EKA-X | DIGI.TRANSISTOR |  |  |
|----------|-------------|-----------------|--|--|

**IC**

|        |             |                 |  |  |
|--------|-------------|-----------------|--|--|
| IC8701 | PIC-28143SY | IFR DETECT UNIT |  |  |
|--------|-------------|-----------------|--|--|

**OTHERS**

|       |               |              |       |  |
|-------|---------------|--------------|-------|--|
| S8701 | CM46978-A01-H | L.E.D.HOLDER |       |  |
| S8702 | QSW0707-001Z  | TACT SWITCH  | POWER |  |
| S8703 | QSW0707-001Z  | TACT SWITCH  | MENU  |  |
| S8704 | QSW0707-001Z  | TACT SWITCH  | CH-   |  |
| S8705 | QSW0707-001Z  | TACT SWITCH  | CH+   |  |
| S8706 | QSW0707-001Z  | TACT SWITCH  | VOL-  |  |
| S8706 | QSW0707-001Z  | TACT SWITCH  | VOL+  |  |

## FRONT AV INPUT PW BOARD ASS'Y (SAC-8604A-M2)

| △ Symbol No.     | Part No.     | Part Name | Description | Local |
|------------------|--------------|-----------|-------------|-------|
| <b>RESISTOR</b>  |              |           |             |       |
| R8401            | NRSA63J-750X | MG R      | 75Ω 1/16W   | J     |
| R8402-03         | NRSA63J-224X | MG R      | 220kΩ 1/16W | J     |
| <b>CAPACITOR</b> |              |           |             |       |
| C8401            | QETN1HM-474Z | E CAP.    | 0.47μF 50V  | M     |
| C8402-03         | QETN1HM-105Z | E CAP.    | 1μF 50V     | M     |
| <b>OTHERS</b>    |              |           |             |       |
| J8401            | CEMN041-001  | PIN JACK  |             |       |
| LC8401           | QQR1199-001  | FILTER    |             |       |

## LF PW BOARD ASS'Y (SAC-9502A-M2)

| △ Symbol No.     | Part No.       | Part Name   | Description  | Local |
|------------------|----------------|-------------|--------------|-------|
| <b>RESISTOR</b>  |                |             |              |       |
| R9997            | QRE121J-5R6Y   | C R         | 5.6Ω 1/2W J  |       |
| △ R9998          | QRZ9041-275    | C R         | 2.7MΩ 1/2W K |       |
| <b>CAPACITOR</b> |                |             |              |       |
| △ C9901          | QFZ9067-104    | MM CAP.     | 0.1μF        |       |
| △ C9902          | QFZ9067-473    | MM CAP.     | 0.047μF      |       |
| △ C9904          | QCZ9052-102    | C CAP.      | 1000pF       |       |
| <b>OTHERS</b>    |                |             |              |       |
| △ CN90PW         | QMPD200-200-JC | POWER CORD  |              |       |
| △ F9901          | QMF0007-5R0J1  | FUSE        | 5A           |       |
| FC9901           | CEMG002-001Z   | FUSE CLIP   |              |       |
| △ LF9902         | QQR0527-003    | LINE FILTER |              |       |
| △ VA9901         | ERZV10V621CS   | VARIATOR    |              |       |

## AV SELECTOR PW BOARD ASS'Y (SAC0S510A-M2)

| △ Symbol No.    | Part No.     | Part Name | Description   | Local |
|-----------------|--------------|-----------|---------------|-------|
| <b>RESISTOR</b> |              |           |               |       |
| R0081           | NRSA63J-102X | MG R      | 1kΩ 1/16W J   |       |
| R0082           | NRSA63J-682X | MG R      | 6.8kΩ 1/16W J |       |
| R0083           | NRSA63J-153X | MG R      | 15kΩ 1/16W J  |       |
| R0084           | NRSA63J-683X | MG R      | 68kΩ 1/16W J  |       |
| R0085           | NRSA63J-332X | MG R      | 3.3kΩ 1/16W J |       |
| R0086           | NRSA63J-333X | MG R      | 33kΩ 1/16W J  |       |
| R0087           | NRSA63J-153X | MG R      | 15kΩ 1/16W J  |       |
| R0088           | NRSA63J-152X | MG R      | 1.5kΩ 1/16W J |       |
| R0089           | NRSA63J-562X | MG R      | 5.6kΩ 1/16W J |       |
| R0090           | NRSA63J-563X | MG R      | 56kΩ 1/16W J  |       |
| R0202           | NRSA63J-101X | MG R      | 100Ω 1/16W J  |       |
| R0210           | NRSA63J-0R0X | MG R      | 0.0Ω 1/16W J  |       |
| R0211           | NRSA63J-153X | MG R      | 15kΩ 1/16W J  |       |
| R0212           | NRSA63J-333X | MG R      | 33kΩ 1/16W J  |       |
| R0213           | NRSA63J-102X | MG R      | 1kΩ 1/16W J   |       |
| R0214           | NRSA63J-181X | MG R      | 180Ω 1/16W J  |       |
| R0215           | NRSA63J-152X | MG R      | 1.5kΩ 1/16W J |       |
| R0216           | NRSA63J-182X | MG R      | 1.8kΩ 1/16W J |       |
| R0217           | NRSA63J-102X | MG R      | 1kΩ 1/16W J   |       |
| R0218           | NRSA63J-222X | MG R      | 2.2kΩ 1/16W J |       |
| R0223           | NRSA63J-0R0X | MG R      | 0.0Ω 1/16W J  |       |
| R0229           | NRSA63J-473X | MG R      | 47kΩ 1/16W J  |       |
| R0230           | NRSA63J-223X | MG R      | 22kΩ 1/16W J  |       |
| R0231           | NRSA63J-101X | MG R      | 100Ω 1/16W J  |       |
| R0232           | NRSA63J-102X | MG R      | 1kΩ 1/16W J   |       |
| R0233           | NRSA63J-272X | MG R      | 2.7kΩ 1/16W J |       |
| R0234           | NRSA63J-102X | MG R      | 1kΩ 1/16W J   |       |
| R0235-36        | NRSA63J-101X | MG R      | 100Ω 1/16W J  |       |
| R0238           | NRSA63J-822X | MG R      | 8.2kΩ 1/16W J |       |
| R0239           | NRSA63J-123X | MG R      | 12kΩ 1/16W J  |       |
| R0241           | NRSA63J-821X | MG R      | 820Ω 1/16W J  |       |
| R0242           | NRSA63J-474X | MG R      | 470kΩ 1/16W J |       |
| R0243-44        | NRSA63J-103X | MG R      | 10kΩ 1/16W J  |       |
| R0247           | NRSA63J-101X | MG R      | 100Ω 1/16W J  |       |
| R0251           | NRSA63J-471X | MG R      | 470Ω 1/16W J  |       |
| R0253           | NRSA63J-681X | MG R      | 680Ω 1/16W J  |       |
| R0254           | NRSA63J-391X | MG R      | 390Ω 1/16W J  |       |
| R0255           | NRSA63J-681X | MG R      | 680Ω 1/16W J  |       |
| R0258           | NRSA63J-101X | MG R      | 100Ω 1/16W J  |       |
| R0259           | NRSA63J-222X | MG R      | 2.2kΩ 1/16W J |       |
| R0261           | NRSA63J-101X | MG R      | 100Ω 1/16W J  |       |
| R0262           | NRSA63J-222X | MG R      | 2.2kΩ 1/16W J |       |

| △ Symbol No.     | Part No.     | Part Name | Description   | Local |
|------------------|--------------|-----------|---------------|-------|
| <b>RESISTOR</b>  |              |           |               |       |
| R0263            | NRSA63J-471X | MG R      | 470Ω 1/16W J  |       |
| R0265            | NRSA63J-102X | MG R      | 1kΩ 1/16W J   |       |
| R0269            | NRSA63J-681X | MG R      | 680Ω 1/16W J  |       |
| R0270            | NRSA63J-102X | MG R      | 1kΩ 1/16W J   |       |
| R0301-02         | NRSA63J-222X | MG R      | 2.2kΩ 1/16W J |       |
| R0303-04         | NRSA63J-221X | MG R      | 220Ω 1/16W J  |       |
| R0305-06         | NRSA63J-0R0X | MG R      | 0.0Ω 1/16W J  |       |
| R0331-34         | NRSA63J-101X | MG R      | 100Ω 1/16W J  |       |
| R0371-74         | NRSA63J-103X | MG R      | 10kΩ 1/16W J  |       |
| R0375-76         | NRSA63J-333X | MG R      | 33kΩ 1/16W J  |       |
| R0377-78         | NRSA63J-472X | MG R      | 4.7kΩ 1/16W J |       |
| R0385            | NRSA63J-223X | MG R      | 22kΩ 1/16W J  |       |
| R0387            | NRSA63J-223X | MG R      | 22kΩ 1/16W J  |       |
| R0391-92         | NRSA63J-221X | MG R      | 220Ω 1/16W J  |       |
| R0393-94         | NRSA63J-823X | MG R      | 82kΩ 1/16W J  |       |
| R0395-96         | NRSA63J-221X | MG R      | 220Ω 1/16W J  |       |
| R0401            | NRSA63J-183X | MG R      | 18kΩ 1/16W J  |       |
| R0402            | NRSA63J-223X | MG R      | 22kΩ 1/16W J  |       |
| R0458            | NRSA63J-333X | MG R      | 33kΩ 1/16W J  |       |
| R0459            | NRSA63J-183X | MG R      | 18kΩ 1/16W J  |       |
| R0501-02         | NRSA63J-102X | MG R      | 1kΩ 1/16W J   |       |
| R0504-05         | NRSA63J-102X | MG R      | 1kΩ 1/16W J   |       |
| R0507-08         | NRSA63J-102X | MG R      | 1kΩ 1/16W J   |       |
| R0509            | NRSA63J-221X | MG R      | 220Ω 1/16W J  |       |
| R0518            | NRSA63J-333X | MG R      | 33kΩ 1/16W J  |       |
| R0519-21         | NRSA63J-750X | MG R      | 75Ω 1/16W J   |       |
| R0522-23         | NRSA63J-224X | MG R      | 220kΩ 1/16W J |       |
| R0528-29         | NRSA63J-0R0X | MG R      | 0.0Ω 1/16W J  |       |
| R0532-33         | NRSA63J-224X | MG R      | 220kΩ 1/16W J |       |
| R0558-61         | NRSA63J-0R0X | MG R      | 0.0Ω 1/16W J  |       |
| R0566-67         | NRSA63J-331X | MG R      | 330Ω 1/16W J  |       |
| R0571            | NRSA63J-101X | MG R      | 100Ω 1/16W J  |       |
| R0573            | NRSA63J-272X | MG R      | 2.7kΩ 1/16W J |       |
| R0574            | NRSA63J-0R0X | MG R      | 0.0Ω 1/16W J  |       |
| R0906            | NRSA63J-0R0X | MG R      | 0.0Ω 1/16W J  |       |
| <b>CAPACITOR</b> |              |           |               |       |
| C0081            | NCB21HK-104X | C CAP.    | 0.1μF 50V K   |       |
| C0082            | QENC1HM-475Z | BP E CAP. | 4.7μF 50V M   |       |
| C0083            | QENC1HM-105Z | BP E CAP. | 1μF 50V M     |       |
| C0084            | QETN1HM-225Z | E CAP.    | 2.2μF 50V M   |       |
| C0085            | NCB21HK-473X | C CAP.    | 0.047μF 50V K |       |
| C0086            | QETN1HM-474Z | E CAP.    | 0.47μF 50V M  |       |
| C0087-88         | NCB21HK-104X | C CAP.    | 0.1μF 50V K   |       |
| C0089            | QETN1HM-335Z | E CAP.    | 3.3μF 50V M   |       |
| C0090            | QETN1HM-105Z | E CAP.    | 1μF 50V M     |       |
| C0091            | QETN1HM-106Z | E CAP.    | 10μF 50V M    |       |
| C0092-93         | QETN1HM-105Z | E CAP.    | 1μF 50V M     |       |
| C0094            | QETN1HM-475Z | E CAP.    | 4.7μF 50V M   |       |
| C0095            | QETN1HM-105Z | E CAP.    | 1μF 50V M     |       |
| C0205            | QETN1HM-476Z | E CAP.    | 47μF 50V M    |       |
| C0206            | NCB31HK-103X | C CAP.    | 0.01μF 50V K  |       |
| C0211            | QENC1EM-106Z | BP E CAP. | 10μF 25V M    |       |
| C0212            | NDC31HJ-101X | C CAP.    | 100pF 50V J   |       |
| C0213            | NDC31HJ-470X | C CAP.    | 47pF 50V J    |       |
| C0214            | NDC31HJ-181X | C CAP.    | 180pF 50V J   |       |
| C0215            | QETN1HM-474Z | E CAP.    | 0.47μF 50V M  |       |
| C0223            | NCB31HK-103X | C CAP.    | 0.01μF 50V K  |       |
| C0226            | NCB31HK-103X | C CAP.    | 0.01μF 50V K  |       |
| C0231-33         | QETN1HM-106Z | E CAP.    | 10μF 50V M    |       |
| C0234            | NCB31HK-103X | C CAP.    | 0.01μF 50V K  |       |
| C0235            | QETN1HM-106Z | E CAP.    | 10μF 50V M    |       |
| C0236            | NCB31HK-103X | C CAP.    | 0.01μF 50V K  |       |
| C0237            | NCB31HK-472X | C CAP.    | 4700pF 50V K  |       |
| C0238-39         | NCB31HK-103X | C CAP.    | 0.01μF 50V K  |       |
| C0241-45         | NCB31HK-103X | C CAP.    | 0.01μF 50V K  |       |
| C0246            | NDC31HJ-181X | C CAP.    | 180pF 50V J   |       |
| C0247-49         | NCB31HK-103X | C CAP.    | 0.01μF 50V K  |       |
| C0251            | QETN1HM-476Z | E CAP.    | 47μF 50V M    |       |
| C0252            | NCB31HK-103X | C CAP.    | 0.01μF 50V K  |       |
| C0255            | NDC31HJ-390X | C CAP.    | 39pF 50V J    |       |

| △ Symbol No.      | Part No.        | Part Name       | Description | Local |
|-------------------|-----------------|-----------------|-------------|-------|
| <b>CAPACITOR</b>  |                 |                 |             |       |
| C0263             | NDC31HJ-150X    | C CAP.          | 15pF 50V    | J     |
| C0264             | QENC1HM-474Z    | BP E CAP.       | 0.47μF 50V  | M     |
| C0265             | NCB31HK-103X    | C CAP.          | 0.01μF 50V  | K     |
| C0309-10          | NCB31HK-102X    | C CAP.          | 1000pF 50V  | K     |
| C0311-12          | NRSA63J-0R0X    | MG R            | 0.0Ω 1/16W  | J     |
| C0331             | QETN1CM-107Z    | E CAP.          | 100μF 16V   | M     |
| C0332             | NCB31HK-103X    | C CAP.          | 0.01μF 50V  | K     |
| C0333             | QETN1EM-476Z    | E CAP.          | 47μF 25V    | M     |
| C0334             | NCB21HK-273X    | C CAP.          | 0.027μF 50V | K     |
| C0335             | QETN1HM-225Z    | E CAP.          | 2.2μF 50V   | M     |
| C0336             | NCB31HK-222X    | C CAP.          | 2200pF 50V  | K     |
| C0337             | NCB21HK-104X    | C CAP.          | 0.1μF 50V   | K     |
| C0338             | QETN1HM-225Z    | E CAP.          | 2.2μF 50V   | M     |
| C0339             | NCB31HK-222X    | C CAP.          | 2200pF 50V  | K     |
| C0340             | NCB21HK-104X    | C CAP.          | 0.1μF 50V   | K     |
| C0343             | QETN1HM-105Z    | E CAP.          | 1μF 50V     | M     |
| C0344-45          | QENC1HM-225Z    | BP E CAP.       | 2.2μF 50V   | M     |
| C0371-72          | QENC1HM-105Z    | BP E CAP.       | 1μF 50V     | M     |
| C0373             | QETN1EM-476Z    | E CAP.          | 47μF 25V    | M     |
| C0391-92          | QETN1HM-474Z    | E CAP.          | 0.47μF 50V  | M     |
| C0401             | QETN1CM-107Z    | E CAP.          | 100μF 16V   | M     |
| C0402-03          | NCF21CZ-105X    | C CAP.          | 1μF 16V     | Z     |
| C0404             | QFV71HJ-224Z    | MF CAP.         | 0.22μF 50V  | J     |
| C0407             | QETN1EM-108Z    | E CAP.          | 1000μF 25V  | M     |
| C0410-11          | QETN1EM-108Z    | E CAP.          | 1000μF 25V  | M     |
| C0412-13          | QETN1HM-105Z    | E CAP.          | 1μF 50V     | M     |
| C0501-02          | NCB31HK-103X    | C CAP.          | 0.01μF 50V  | K     |
| C0503             | QETN1HM-226Z    | E CAP.          | 22μF 50V    | M     |
| C0504             | QETN1EM-476Z    | E CAP.          | 47μF 25V    | M     |
| C0505             | QENC1HM-474Z    | BP E CAP.       | 0.47μF 50V  | M     |
| C0508             | QETN1HM-474Z    | E CAP.          | 0.47μF 50V  | M     |
| C0509             | NCB31HK-103X    | C CAP.          | 0.01μF 50V  | K     |
| C0511             | QETN1HM-474Z    | E CAP.          | 0.47μF 50V  | M     |
| C0512-13          | QETN1HM-105Z    | E CAP.          | 1μF 50V     | M     |
| C0520-21          | QETN1HM-105Z    | E CAP.          | 1μF 50V     | M     |
| C0531-32          | NCB31HK-103X    | C CAP.          | 0.01μF 50V  | K     |
| C0536-39          | NCB31HK-103X    | C CAP.          | 0.01μF 50V  | K     |
| <b>COIL</b>       |                 |                 |             |       |
| L0202             | QLL244K-150Z    | COIL            | 15μH        | K     |
| L0211             | QLL244K-4R7Z    | COIL            | 4.7μH       | K     |
| L0242-43          | QLL244K-4R7Z    | COIL            | 4.7μH       | K     |
| L0261             | QLL244K-150Z    | COIL            | 15μH        | K     |
| <b>DIODE</b>      |                 |                 |             |       |
| D0391-92          | MTZJ10C-T2      | ZENER DIODE     |             |       |
| D0501-02          | MTZJ10C-T2      | ZENER DIODE     |             |       |
| D0504             | MTZJ10C-T2      | ZENER DIODE     |             |       |
| D0509             | MTZJ10C-T2      | ZENER DIODE     |             |       |
| D0511             | MTZJ10C-T2      | ZENER DIODE     |             |       |
| D0515-19          | MTZJ10C-T2      | ZENER DIODE     |             |       |
| D0521             | MTZJ10C-T2      | ZENER DIODE     |             |       |
| <b>TRANSISTOR</b> |                 |                 |             |       |
| Q0211-12          | 2SC2412K/QR/-X  | SI.TRANSISTOR   |             |       |
| Q0218             | 2SC2412K/QR/-X  | SI.TRANSISTOR   |             |       |
| Q0219             | 2SA1037AK/QR/-X | SI.TRANSISTOR   |             |       |
| Q0251             | 2SC2412K/QR/-X  | SI.TRANSISTOR   |             |       |
| Q0252             | 2SA1037AK/QR/-X | SI.TRANSISTOR   |             |       |
| Q0253             | 2SC2412K/QR/-X  | SI.TRANSISTOR   |             |       |
| Q0261-62          | 2SC2412K/QR/-X  | SI.TRANSISTOR   |             |       |
| Q0263             | 2SA1037AK/QR/-X | SI.TRANSISTOR   |             |       |
| Q0301-02          | DTC124EKA-X     | DIGI.TRANSISTOR |             |       |
| Q0385             | DTC323TK-X      | DIGI.TRANSISTOR |             |       |
| Q0387             | DTC323TK-X      | DIGI.TRANSISTOR |             |       |
| Q0453             | 2SC2412K/QR/-X  | SI.TRANSISTOR   |             |       |
| Q0454             | DTC124EKA-X     | DIGI.TRANSISTOR |             |       |
| Q0509             | 2SC2412K/QR/-X  | SI.TRANSISTOR   |             |       |

| △ Symbol No. | Part No.   | Part Name      | Description | Local |
|--------------|------------|----------------|-------------|-------|
| <b>IC</b>    |            |                |             |       |
| IC0001       | UPC1851BCU | I.C.(MONO-ANA) |             |       |
| IC0201       | TC90A53N   | I.C.(DIGI-MOS) |             |       |
| IC0371       | BA15218N   | I.C.(MONO-ANA) |             |       |
| IC0401       | LA4485     | I.C.(MONO-ANA) |             |       |
| IC0501       | CXA2089Q-X | I.C.(MONO-ANA) |             |       |

**OTHERS**

|          |             |          |
|----------|-------------|----------|
| J0501    | QNZ0454-001 | PIN JACK |
| J0502-03 | QNN0348-001 | PIN JACK |

## REMOTE CONTROL UNIT PARTS LIST (RM-C306-1A)

| △ Ref.No. | Part No.    | Part Name     | Description | Local |
|-----------|-------------|---------------|-------------|-------|
|           | UR52EC1286A | BATTERY COVER |             |       |

## DIFFERENCE PARTS LIST BETWEEN AV-36230/H AND AV-36230/R

The picture tubes used for the models AV-36230/H and AV-36230/R are difference. The electrical parts are also difference according to the PICTURE TUBE.

In the DIFFERENCE PARTS LIST BETWEEN AV-36230/H and AV-36230/R, only difference points between these models are written. For other parts not mentioned in the list, please refer to the PARTS LIST(P40 – P45) for the AV-36230/H.

## DIFFERENCE PARTS LIST

### MAIN PWB

| ⚠ | Symbol No. | Part No.                          |                                  | Part Name       |
|---|------------|-----------------------------------|----------------------------------|-----------------|
|   |            | AV-36230/H                        | AV-36230/R                       |                 |
|   |            | <b>SAC-1540A-M2</b>               | <b>SAC-1539A-M2</b>              | <b>MAIN PWB</b> |
|   | R1776      | NRSA63J-272X<br>(2.7kΩ, 1/16W, J) | NRSA63J-123X<br>(12kΩ, 1/16W, J) | C R             |
| ⚠ | C1515      | QFZ0197-564<br>(0.56μF, 250V, J)  | QFZ0197-624<br>(0.62μF, 250V, J) | MPP CAP.        |

### CRT SOCKET PWB

| ⚠ | Symbol No. | Part No.            |                     | Part Name             |
|---|------------|---------------------|---------------------|-----------------------|
|   |            | AV-36230/H          | AV-36230/R          |                       |
|   |            | <b>SAC-3505A-M2</b> | <b>SAC-3504A-M2</b> | <b>CRT SOCKET PWB</b> |

### CRT SOCKET PW BOARD ASS'Y (SAC-3504A-M2)

| ⚠                 | Symbol No. | Part No.      | Part Name     | Description    | Local |
|-------------------|------------|---------------|---------------|----------------|-------|
| <b>RESISTOR</b>   |            |               |               |                |       |
|                   | R3354-56   | NRSA63J-221X  | MG R          | 220Ω 1/16W J   |       |
|                   | R3357-59   | NRSA63J-101X  | MG R          | 100Ω 1/16W J   |       |
|                   | R3360-62   | QRZ0111-152   | C R           | 1.5kΩ 1/2W K   |       |
|                   | R3363-65   | QRG029J-103   | OM R          | 10kΩ 2W J      |       |
|                   | R3366-68   | NRSA63J-182X  | MG R          | 1.8kΩ 1/16W J  |       |
|                   | R3372-74   | NRSA63J-221X  | MG R          | 220Ω 1/16W J   |       |
|                   | R3375-77   | NRSA63J-0R0X  | MG R          | 0.0Ω 1/16W J   |       |
|                   | R3381      | QRE121J-394Y  | C R           | 390kΩ 1/2W J   |       |
|                   | R3391      | NRSA63J-152X  | MG R          | 1.5kΩ 1/16W J  |       |
|                   | R3392      | NRSA63J-392X  | MG R          | 3.9kΩ 1/16W J  |       |
|                   | R3393-95   | NRSA63J-102X  | MG R          | 1kΩ 1/16W J    |       |
| <b>CAPACITOR</b>  |            |               |               |                |       |
|                   | C3354-55   | NDC31HJ-331X  | C CAP.        | 330pF 50V J    |       |
|                   | C3356      | NDC31HJ-391X  | C CAP.        | 390pF 50V J    |       |
|                   | C3357      | QETN1CM-107Z  | E CAP.        | 100μF 16V M    |       |
|                   | C3382      | QCZ0121-102   | C CAP.        | 1000pF 3000V Z |       |
|                   | C3391      | QETN1AM-227Z  | E CAP.        | 220μF 10V M    |       |
|                   | C3392      | NDC31HJ-101X  | C CAP.        | 100pF 50V J    |       |
| <b>COIL</b>       |            |               |               |                |       |
|                   | L3381      | QQL244K-101Z  | PEAKING COIL  | 100μH          | K     |
| <b>DIODE</b>      |            |               |               |                |       |
|                   | D3391      | 1SS133-T2     | SI.DIODE      |                |       |
| <b>TRANSISTOR</b> |            |               |               |                |       |
|                   | Q3351-53   | 2SC4544-LB    | SI.TRANSISTOR |                |       |
|                   | Q3391      | 2SA933AS/QR/T | SI.TRANSISTOR |                |       |
| <b>OTHERS</b>     |            |               |               |                |       |
| ⚠                 | SK3351     | QNZ0464-001   | C.R.T.SOCKET  |                |       |

# PRINTED WIRING BOARD PARTS LIST (AV-36260/R)

## MAIN PW BOARD ASS'Y (SAC-1533A-M2)

| △               | Symbol No. | Part No.     | Part Name | Description   | Local | △               | Symbol No. | Part No.      | Part Name   | Description       | Local    |  |
|-----------------|------------|--------------|-----------|---------------|-------|-----------------|------------|---------------|-------------|-------------------|----------|--|
| <b>RESISTOR</b> |            |              |           |               |       | <b>RESISTOR</b> |            |               |             |                   |          |  |
|                 | R1001      | NRSA63J-473X | MG R      | 47kΩ 1/16W J  |       |                 | R1522      | NRSA63J-561X  | MG R        | 560Ω 1/16W J      |          |  |
|                 | R1002      | NRSA63J-102X | MG R      | 1kΩ 1/16W J   |       |                 | R1523      | QRJ146J-333X  | C R         | 33kΩ 1/4W J       |          |  |
|                 | R1003-04   | NRSA63J-0R0X | MG R      | 0.0Ω 1/16W J  |       | △               | R1525      | QRZ9011-470   | F R         | 47Ω 1/2W J        |          |  |
|                 | R1011      | NRSA63J-820X | MG R      | 82Ω 1/16W J   |       |                 | R1526      | QRE121J-272Y  | C R         | 2.7kΩ 1/2W J      |          |  |
|                 | R1012      | NRSA63J-182X | MG R      | 1.8kΩ 1/16W J |       |                 | R1527-28   | QRE121J-154Y  | C R         | 150kΩ 1/2W J      |          |  |
|                 | R1013      | NRSA63J-562X | MG R      | 5.6kΩ 1/16W J |       |                 | R1529      | NRSA63J-331X  | MG R        | 330Ω 1/16W J      |          |  |
|                 | R1014      | QRE121J-101Y | C R       | 100Ω 1/2W J   |       | △               | R1531      | QRJ146J-391X  | C R         | 390Ω 1/4W J       |          |  |
|                 | R1015      | NRSA63J-180X | MG R      | 18Ω 1/16W J   |       |                 | R1532      | NRSA63J-273X  | MG R        | 27kΩ 1/16W J      |          |  |
|                 | R1016      | NRSA63J-270X | MG R      | 27Ω 1/16W J   |       |                 | R1533-34   | NRSA63J-123X  | MG R        | 12kΩ 1/16W J      |          |  |
|                 | R1018      | NRSA63J-104X | MG R      | 100kΩ 1/16W J |       | △               | R1535      | NRVA02D-242X  | MF R        | 2.4kΩ 1/10W ±0.5% |          |  |
|                 | R1020      | NRSA63J-332X | MG R      | 3.3kΩ 1/16W J |       | △               | R1537      | NRZ0032-7151X | MF R        | 7.15kΩ            |          |  |
|                 | R1021      | NRSA63J-123X | MG R      | 12kΩ 1/16W J  |       |                 | R1538      | NRSA63J-333X  | MG R        | 33kΩ 1/16W J      |          |  |
|                 | R1022      | NRSA63J-151X | MG R      | 150Ω 1/16W J  |       |                 | R1543      | QRE121J-122Y  | C R         | 1.2kΩ 1/2W J      |          |  |
|                 | R1023      | NRSA63J-101X | MG R      | 100Ω 1/16W J  |       |                 | R1544      | QRE121J-392Y  | C R         | 3.9kΩ 1/2W J      |          |  |
|                 | R1024      | NRSA63J-102X | MG R      | 1kΩ 1/16W J   |       |                 | R1545      | QRE121J-822Y  | C R         | 8.2kΩ 1/2W J      |          |  |
|                 | R1025      | NRSA63J-561X | MG R      | 560Ω 1/16W J  |       |                 | R1546      | NRSA63J-331X  | MG R        | 330Ω 1/16W J      |          |  |
|                 | R1026      | NRSA63J-331X | MG R      | 330Ω 1/16W J  |       |                 | R1547      | NRSA63J-104X  | MG R        | 100kΩ 1/16W J     |          |  |
|                 | R1028      | NRSA63J-821X | MG R      | 820Ω 1/16W J  |       |                 | R1548      | QRE121J-152Y  | C R         | 1.5kΩ 1/2W J      |          |  |
|                 | R1038      | NRSA63J-272X | MG R      | 2.7kΩ 1/16W J |       |                 | R1553      | QRL039J-180   | OM R        | 18Ω 3W J          |          |  |
|                 | R1039-40   | NRSA63J-0R0X | MG R      | 0.0Ω 1/16W J  |       |                 | R1601-03   | NRSA63J-750X  | MG R        | 75Ω 1/16W J       |          |  |
|                 | R1041      | NRSA63J-272X | MG R      | 2.7kΩ 1/16W J |       |                 | R1610-12   | NRSA63J-221X  | MG R        | 220Ω 1/16W J      |          |  |
|                 | R1042-43   | NRSA63J-102X | MG R      | 1kΩ 1/16W J   |       |                 | R1700-02   | NRSA63J-102X  | MG R        | 1kΩ 1/16W J       |          |  |
|                 | R1045-46   | NRSA63J-0R0X | MG R      | 0.0Ω 1/16W J  |       |                 | R1704-05   | NRSA63J-472X  | MG R        | 4.7kΩ 1/16W J     |          |  |
|                 | R1047      | NRSA63J-153X | MG R      | 15kΩ 1/16W J  |       |                 | R1706-07   | NRSA63J-103X  | MG R        | 10kΩ 1/16W J      |          |  |
|                 | R1048      | NRSA63J-154X | MG R      | 150kΩ 1/16W J |       |                 | R1708-09   | NRSA63J-101X  | MG R        | 100Ω 1/16W J      |          |  |
|                 | R1101-02   | NRSA63J-101X | MG R      | 100Ω 1/16W J  |       |                 | R1714      | NRSA63J-102X  | MG R        | 1kΩ 1/16W J       |          |  |
|                 | R1111      | NRSA63J-105X | MG R      | 1MΩ 1/16W J   |       |                 | R1715      | NRSA63J-103X  | MG R        | 10kΩ 1/16W J      |          |  |
|                 | R1131      | NRSA63J-272X | MG R      | 2.7kΩ 1/16W J |       |                 | R1721-22   | NRSA63J-102X  | MG R        | 1kΩ 1/16W J       |          |  |
|                 | R1134      | NRSA63J-562X | MG R      | 5.6kΩ 1/16W J |       |                 | R1724      | NRSA63J-102X  | MG R        | 1kΩ 1/16W J       |          |  |
|                 | R1135      | NRSA63J-102X | MG R      | 1kΩ 1/16W J   |       |                 | R1726-28   | NRSA63J-102X  | MG R        | 1kΩ 1/16W J       |          |  |
|                 | R1140      | NRSA63J-562X | MG R      | 5.6kΩ 1/16W J |       |                 | R1729      | NRSA63J-223X  | MG R        | 22kΩ 1/16W J      |          |  |
|                 | R1141      | NRSA63J-0R0X | MG R      | 0.0Ω 1/16W J  |       |                 | R1731-32   | NRSA63J-101X  | MG R        | 100Ω 1/16W J      |          |  |
|                 | R1201      | NRSA63J-333X | MG R      | 33kΩ 1/16W J  |       |                 | R1733-34   | NRSA63J-272X  | MG R        | 2.7kΩ 1/16W J     |          |  |
|                 | R1231      | NRSA63J-182X | MG R      | 1.8kΩ 1/16W J |       |                 | R1737      | NRSA63J-222X  | MG R        | 2.2kΩ 1/16W J     |          |  |
|                 | R1237      | NRSA63J-392X | MG R      | 3.9kΩ 1/16W J |       |                 | R1738      | NRSA63J-102X  | MG R        | 1kΩ 1/16W J       |          |  |
|                 | R1238      | NRSA63J-473X | MG R      | 47kΩ 1/16W J  |       |                 | R1739      | NRSA63J-272X  | MG R        | 2.7kΩ 1/16W J     |          |  |
|                 | R1241      | NRSA63J-332X | MG R      | 3.3kΩ 1/16W J |       |                 | R1740      | NRSA63J-103X  | MG R        | 10kΩ 1/16W J      |          |  |
|                 | R1243      | NRSA63J-152X | MG R      | 1.5kΩ 1/16W J |       |                 | R1741      | NRSA63J-0R0X  | MG R        | 0.0Ω 1/16W J      |          |  |
|                 | R1281      | NRSA63J-182X | MG R      | 1.8kΩ 1/16W J |       |                 | R1742-43   | NRSA63J-103X  | MG R        | 10kΩ 1/16W J      |          |  |
|                 | R1282      | NRSA63J-392X | MG R      | 3.9kΩ 1/16W J |       |                 | R1748      | NRSA63J-103X  | MG R        | 10kΩ 1/16W J      |          |  |
|                 | R1283      | NRSA63J-681X | MG R      | 680Ω 1/16W J  |       |                 | R1749-51   | NRSA63J-222X  | MG R        | 2.2kΩ 1/16W J     |          |  |
|                 | R1286      | NRSA63J-472X | MG R      | 4.7kΩ 1/16W J |       |                 | R1752      | NRSA63J-102X  | MG R        | 1kΩ 1/16W J       |          |  |
|                 | R1287      | NRSA63J-101X | MG R      | 100Ω 1/16W J  |       |                 | R1753      | NRSA63J-0R0X  | MG R        | 0.0Ω 1/16W J      |          |  |
|                 | R1288      | NRSA02J-471X | MG R      | 470Ω 1/10W J  |       |                 | R1754      | NRSA63J-102X  | MG R        | 1kΩ 1/16W J       |          |  |
|                 | R1289      | NRSA63J-154X | MG R      | 150kΩ 1/16W J |       |                 | R1755      | NRSA63J-153X  | MG R        | 15kΩ 1/16W J      |          |  |
|                 | R1290      | NRSA02J-561X | MG R      | 560Ω 1/10W J  |       |                 | R1756      | NRSA63J-103X  | MG R        | 10kΩ 1/16W J      |          |  |
|                 | R1291      | NRSA63J-103X | MG R      | 10kΩ 1/16W J  |       |                 | R1764-68   | NRSA63J-221X  | MG R        | 220Ω 1/16W J      |          |  |
|                 | R1292      | NRSA63J-123X | MG R      | 12kΩ 1/16W J  |       |                 | R1769-70   | NRSA63J-682X  | MG R        | 6.8kΩ 1/16W J     |          |  |
|                 | R1301-03   | NRSA63J-222X | MG R      | 2.2kΩ 1/16W J |       |                 | R1772      | NRSA63J-103X  | MG R        | 10kΩ 1/16W J      |          |  |
|                 | R1304-06   | NRSA63J-101X | MG R      | 100Ω 1/16W J  |       |                 | R1774      | NRSA63J-682X  | MG R        | 6.8kΩ 1/16W J     |          |  |
|                 | R1354-55   | NRSA63J-0R0X | MG R      | 0.0Ω 1/16W J  |       |                 | R1775      | NRSA63J-473X  | MG R        | 47kΩ 1/16W J      |          |  |
|                 | R1356      | NRSA63J-123X | MG R      | 12kΩ 1/16W J  |       |                 | R1776      | NRSA63J-123X  | MG R        | 12kΩ 1/16W J      |          |  |
|                 | R1359      | NRSA63J-103X | MG R      | 10kΩ 1/16W J  |       |                 | R1777      | NRSA63J-103X  | MG R        | 10kΩ 1/16W J      |          |  |
|                 | R1360      | NRSA63J-0R0X | MG R      | 0.0Ω 1/16W J  |       |                 | R1793-95   | NRSA63J-331X  | MG R        | 330Ω 1/16W J      |          |  |
|                 | R1401      | NRSA63J-822X | MG R      | 8.2kΩ 1/16W J |       |                 | R1798-99   | NRSA63J-103X  | MG R        | 10kΩ 1/16W J      |          |  |
|                 | R1403      | QRX01GJ-1R0  | MF R      | 1.0Ω 1W J     |       |                 | R1800      | NRSA63J-103X  | MG R        | 10kΩ 1/16W J      |          |  |
|                 | R1404      | QRE121J-100Y | C R       | 10Ω 1/2W J    |       |                 | R1806      | NRSA63J-102X  | MG R        | 1kΩ 1/16W J       |          |  |
|                 | R1405      | NRSA63J-103X | MG R      | 10kΩ 1/16W J  |       |                 | R1807      | NRSA63J-222X  | MG R        | 2.2kΩ 1/16W J     |          |  |
|                 | R1407      | NRSA02J-0R0X | MG R      | 0.0Ω 1/10W J  |       |                 | R1810      | NRSA63J-0R0X  | MG R        | 0.0Ω 1/16W J      |          |  |
|                 | R1411-12   | NRSA63J-103X | MG R      | 10kΩ 1/16W J  |       |                 | R1811      | NRSA63J-473X  | MG R        | 47kΩ 1/16W J      |          |  |
|                 | R1414      | QRL029J-221  | OM R      | 220Ω 2W J     |       |                 | R1812      | NRSA63J-102X  | MG R        | 1kΩ 1/16W J       |          |  |
|                 | R1431      | QRE121J-272Y | C R       | 2.7kΩ 1/2W J  |       |                 | R1814      | NRSA63J-104X  | MG R        | 100kΩ 1/16W J     |          |  |
|                 | R1432      | NRSA63J-104X | MG R      | 100kΩ 1/16W J |       |                 | R1815      | NRSA63J-154X  | MG R        | 150kΩ 1/16W J     |          |  |
|                 | R1433      | NRSA63J-473X | MG R      | 47kΩ 1/16W J  |       |                 | R1816      | NRSA63J-0R0X  | MG R        | 0.0Ω 1/16W J      |          |  |
|                 | R1434      | NRSA63J-822X | MG R      | 8.2kΩ 1/16W J |       |                 | R1817      | NRSA63J-104X  | MG R        | 100kΩ 1/16W J     |          |  |
|                 | R1435      | NRSA63J-103X | MG R      | 10kΩ 1/16W J  |       |                 | R1818      | NRSA63J-0R0X  | MG R        | 0.0Ω 1/16W J      |          |  |
|                 | R1501      | NRSA63J-0R0X | MG R      | 0.0Ω 1/16W J  |       |                 | R1821      | NRSA63J-104X  | MG R        | 100kΩ 1/16W J     |          |  |
|                 | R1502      | NRSA63J-271X | MG R      | 270Ω 1/16W J  |       |                 | R1824      | NRSA63J-103X  | MG R        | 10kΩ 1/16W J      |          |  |
|                 | R1503      | QRE121J-103Y | C R       | 10kΩ 1/2W J   |       |                 | R1827      | NRSA63J-102X  | MG R        | 1kΩ 1/16W J       |          |  |
|                 | R1504-05   | QRL039J-152  | OM R      | 1.5kΩ 3W J    |       |                 | △          | R1857         | QRL029J-270 | OM R              | 27Ω 2W J |  |
|                 | R1511      | QRE121J-220Y | C R       | 22Ω 1/2W J    |       |                 | △          | R1858         | QRG01GJ-270 | OM R              | 27Ω 1W J |  |
|                 | R1512      | QRE121J-681Y | C R       | 680Ω 1/2W J   |       |                 | R1860      | NRSA63J-562X  | MG R        | 5.6kΩ 1/16W J     |          |  |

| △ Symbol No.    | Part No.     | Part Name | Description | Local |
|-----------------|--------------|-----------|-------------|-------|
| <b>RESISTOR</b> |              |           |             |       |
| △ R1901         | QRF074K-R47  | UNF R     | 0.47Ω 7W    | K     |
| △ R1909         | QRG01GJ-470  | OM R      | 47Ω 1W      | J     |
| R1911           | QRE121J-223Y | C R       | 22kΩ 1/2W   | J     |
| R1912-13        | QRT029J-R22  | MF R      | 0.22Ω 2W    | J     |
| R1914           | QRK126J-681X | C R       | 680Ω 1/2W   | J     |
| R1915           | QRE121J-270Y | C R       | 27Ω 1/2W    | J     |
| R1917           | QRK126J-332X | C R       | 3.3kΩ 1/2W  | J     |
| R1918           | QRE121J-222Y | C R       | 2.2kΩ 1/2W  | J     |
| R1919           | QRE121J-684Y | C R       | 680kΩ 1/2W  | J     |
| R1924           | QRE121J-222Y | C R       | 2.2kΩ 1/2W  | J     |
| R1930           | QRE121J-223Y | C R       | 22kΩ 1/2W   | J     |
| R1939           | QRT039J-2R2  | MF R      | 2.2Ω 3W     | J     |
| R1940           | QRE121J-181Y | C R       | 180Ω 1/2W   | J     |
| R1941           | QRL029J-183  | OM R      | 18kΩ 2W     | J     |
| R1943           | NRSA63J-104X | MG R      | 100kΩ 1/16W | J     |
| R1944           | NRSA63J-122X | MG R      | 1.2kΩ 1/16W | J     |
| R1951           | NRSA63J-473X | MG R      | 47kΩ 1/16W  | J     |
| R1952           | NRSA63J-102X | MG R      | 1kΩ 1/16W   | J     |
| R1953           | QRE121J-151Y | C R       | 150Ω 1/2W   | J     |
| R1973           | QRE121J-272Y | C R       | 2.7kΩ 1/2W  | J     |
| R1975           | QRE121J-223Y | C R       | 22kΩ 1/2W   | J     |
| R1977           | QRE121J-473Y | C R       | 47kΩ 1/2W   | J     |
| R1978           | NRSA63J-333X | MG R      | 33kΩ 1/16W  | J     |
| R1979-80        | QRT029J-1R2  | MF R      | 1.2Ω 2W     | J     |

| <b>CAPACITOR</b> |              |           |             |   |
|------------------|--------------|-----------|-------------|---|
| C1001            | QETN1HM-475Z | E CAP.    | 4.7μF 50V   | M |
| C1002            | QETN1HM-106Z | E CAP.    | 10μF 50V    | M |
| C1003            | QETN1CM-108Z | E CAP.    | 1000μF 16V  | M |
| C1011-12         | NCB31HK-103X | C CAP.    | 0.01μF 50V  | K |
| C1014            | QETN1CM-107Z | E CAP.    | 100μF 16V   | M |
| C1015-16         | NCB31HK-103X | C CAP.    | 0.01μF 50V  | K |
| C1021            | QFV71HJ-824Z | MF CAP.   | 0.82μF 50V  | J |
| C1023            | QETN1CM-107Z | E CAP.    | 100μF 16V   | M |
| C1024            | NCB31HK-103X | C CAP.    | 0.01μF 50V  | K |
| C1025            | NCB31HK-102X | C CAP.    | 1000pF 50V  | K |
| C1026            | QETN1HM-474Z | E CAP.    | 0.47μF 50V  | M |
| C1027            | NCB21HK-104X | C CAP.    | 0.1μF 50V   | K |
| C1028            | QETN1HM-106Z | E CAP.    | 10μF 50V    | M |
| C1030            | NCB31HK-103X | C CAP.    | 0.01μF 50V  | K |
| C1034            | NCB31HK-103X | C CAP.    | 0.01μF 50V  | K |
| C1036            | QETN1AM-477Z | E CAP.    | 470μF 10V   | M |
| C1037            | NCB31HK-103X | C CAP.    | 0.01μF 50V  | K |
| C1038            | QETN1CM-107Z | E CAP.    | 100μF 16V   | M |
| C1041-42         | QETN1HM-106Z | E CAP.    | 10μF 50V    | M |
| C1043-44         | NDC31HJ-470X | C CAP.    | 47pF 50V    | J |
| C1045            | QETN1HM-106Z | E CAP.    | 10μF 50V    | M |
| C1046            | NCB31HK-103X | C CAP.    | 0.01μF 50V  | K |
| C1047            | NDC21HJ-330X | C CAP.    | 33pF 50V    | J |
| C1048            | NCB31HK-103X | C CAP.    | 0.01μF 50V  | K |
| C1111            | QETN0JM-228Z | E CAP.    | 2200μF 6.3V | M |
| C1112            | NCB31HK-103X | C CAP.    | 0.01μF 50V  | K |
| C1113            | QETN1HM-474Z | E CAP.    | 0.47μF 50V  | M |
| C1114            | QETN1HM-105Z | E CAP.    | 1μF 50V     | M |
| C1115            | QFV71HJ-104Z | MF CAP.   | 0.1μF 50V   | J |
| C1116            | NCB21HK-104X | C CAP.    | 0.1μF 50V   | K |
| C1131            | NDC31HJ-470X | C CAP.    | 47pF 50V    | J |
| C1136            | QENC1CM-106Z | BP E CAP. | 10μF 16V    | M |
| C1151            | NCB31HK-103X | C CAP.    | 0.01μF 50V  | K |
| C1152            | QENC1HM-105Z | BP E CAP. | 1μF 50V     | M |
| C1201            | NDC31HJ-100X | C CAP.    | 10pF 50V    | J |
| C1202            | QETN1HM-224Z | E CAP.    | 0.22μF 50V  | M |
| C1203            | NCB31HK-222X | C CAP.    | 2200pF 50V  | K |
| C1233            | NDC31HJ-560X | C CAP.    | 56pF 50V    | J |
| C1237            | NCB31HK-103X | C CAP.    | 0.01μF 50V  | K |
| C1281            | QFV71HJ-474Z | MF CAP.   | 0.47μF 50V  | J |
| C1282            | QETN1CM-227Z | E CAP.    | 220μF 16V   | M |
| C1283            | NCB31HK-103X | C CAP.    | 0.01μF 50V  | K |
| C1284            | QETN1HM-225Z | E CAP.    | 2.2μF 50V   | M |
| C1285            | NCB31HK-103X | C CAP.    | 0.01μF 50V  | K |
| C1286            | QETN1HM-106Z | E CAP.    | 10μF 50V    | M |
| C1287            | QETN1CM-107Z | E CAP.    | 100μF 16V   | M |

| △ Symbol No.     | Part No.      | Part Name | Description       | Local |
|------------------|---------------|-----------|-------------------|-------|
| <b>CAPACITOR</b> |               |           |                   |       |
| C1288            | NCB31HK-103X  | C CAP.    | 0.01μF 50V        | K     |
| C1352            | QETN1CM-336Z  | E CAP.    | 33μF 16V          | M     |
| C1354            | QFV71HJ-154Z  | MF CAP.   | 0.15μF 50V        | J     |
| C1391            | QETN1CM-107Z  | E CAP.    | 100μF 16V         | M     |
| C1392            | NCB31HK-103X  | C CAP.    | 0.01μF 50V        | K     |
| C1393-95         | NCB21HK-104X  | C CAP.    | 0.1μF 50V         | K     |
| C1401            | NDC21HJ-152X  | C CAP.    | 1500pF 50V        | J     |
| C1403            | NCB21HK-273X  | C CAP.    | 0.027μF 50V       | K     |
| C1404            | QETN1VM-107Z  | E CAP.    | 100μF 35V         | M     |
| C1405            | QCS32HJ-100Z  | C CAP.    | 10pF 500V         | J     |
| C1407            | QFLC2AK-563Z  | M CAP.    | 0.056μF 100V      | K     |
| C1410            | QFLC2AJ-104Z  | M CAP.    | 0.1μF 100V        | J     |
| C1411            | QETN1HM-105Z  | E CAP.    | 1μF 50V           | M     |
| C1415            | NCB21HK-104X  | C CAP.    | 0.1μF 50V         | K     |
| C1421            | QEHQ1VM-108   | E CAP.    | 1000μF 35V        | M     |
| C1431            | QETN1HM-105Z  | E CAP.    | 1μF 50V           | M     |
| C1432            | QETN1EM-476Z  | E CAP.    | 47μF 25V          | M     |
| C1501            | QCB32HK-151Z  | C CAP.    | 150pF 500V        | K     |
| C1502            | QCB32HK-331Z  | C CAP.    | 330pF 500V        | K     |
| C1503            | QEHHR2CM-105Z | E CAP.    | 1μF 160V          | M     |
| C1504            | QEZ0203-107   | E CAP.    | 100μF 160V        | M     |
| C1507-08         | QEM61HK-475Z  | E CAP.    | 4.7μF 50V         | K     |
| △ C1510          | QFZ0196-502   | MPP CAP.  | 5000pF 1.5kVH±3%  |       |
| △ C1513          | QFZ0198-133   | MPP CAP.  | 0.013μF 1.5kVH±3% |       |
| △ C1514          | QFP32GJ-183   | PP CAP.   | 0.018μF 400V      | J     |
| △ C1515          | QFZ0197-624   | MPP CAP.  | 0.62μF 250V       | J     |
| C1516            | QCB32HK-561Z  | C CAP.    | 560pF 500V        | K     |
| C1521            | QETN2EM-106Z  | E CAP.    | 10μF 250V         | M     |
| C1523            | QEHHR1EM-108Z | E CAP.    | 1000μF 25V        | M     |
| C1524            | QETN1EM-108Z  | E CAP.    | 1000μF 25V        | M     |
| C1525            | QETN1VM-107Z  | E CAP.    | 100μF 35V         | M     |
| C1526            | QFV21HJ-824Z  | MF CAP.   | 0.82μF 50V        | J     |
| C1527            | QFLC2AJ-103Z  | M CAP.    | 0.01μF 100V       | J     |
| C1531            | QCB32HK-102Z  | C CAP.    | 1000pF 500V       | K     |
| C1533            | QETN1HM-106Z  | E CAP.    | 10μF 50V          | M     |
| C1601-03         | QETN1EM-476Z  | E CAP.    | 47μF 25V          | M     |
| C1609-11         | QFV71HJ-104Z  | MF CAP.   | 0.1μF 50V         | J     |
| C1612            | QETN1HM-105Z  | E CAP.    | 1μF 50V           | M     |
| C1700            | NCB31HK-102X  | C CAP.    | 1000pF 50V        | K     |
| C1703            | NDC31HJ-181X  | C CAP.    | 180pF 50V         | J     |
| C1706            | QETN1HM-105Z  | E CAP.    | 1μF 50V           | M     |
| C1707            | QETN1CM-107Z  | E CAP.    | 100μF 16V         | M     |
| C1710            | NCB21EK-683X  | C CAP.    | 0.068μF 25V       | K     |
| C1721            | NCB31HK-103X  | C CAP.    | 0.01μF 50V        | K     |
| C1722-23         | NDC31HJ-390X  | C CAP.    | 39pF 50V          | J     |
| C1724            | NDC31HJ-471X  | C CAP.    | 470pF 50V         | J     |
| C1726            | NDC21HJ-561X  | C CAP.    | 560pF 50V         | J     |
| C1800            | QETN1CM-107Z  | E CAP.    | 100μF 16V         | M     |
| C1801            | NCB21HK-104X  | C CAP.    | 0.1μF 50V         | K     |
| C1802            | QETN1CM-107Z  | E CAP.    | 100μF 16V         | M     |
| C1803            | QETN1HM-106Z  | E CAP.    | 10μF 50V          | M     |
| C1804            | NDC31HJ-102X  | C CAP.    | 1000pF 50V        | J     |
| C1805            | NCB31HK-153X  | C CAP.    | 0.015μF 50V       | K     |
| C1806-07         | QETN1HM-106Z  | E CAP.    | 10μF 50V          | M     |
| C1810            | QETN1HM-474Z  | E CAP.    | 0.47μF 50V        | M     |
| C1811            | QETN1HM-105Z  | E CAP.    | 1μF 50V           | M     |
| C1813            | NCB31HK-102X  | C CAP.    | 1000pF 50V        | K     |
| C1816            | NCB31HK-153X  | C CAP.    | 0.015μF 50V       | K     |
| C1853-54         | QETN1CM-227Z  | E CAP.    | 220μF 16V         | M     |
| C1856            | QETN1CM-227Z  | E CAP.    | 220μF 16V         | M     |
| C1857            | QETN1CM-477Z  | E CAP.    | 470μF 16V         | M     |
| △ C1904-06       | QCZ9054-102   | C CAP.    | 1000pF 250V       | Z     |
| △ C1907          | QEZ0169-477   | E CAP.    | 470μF 200V        | M     |
| △ C1908          | QCZ9054-102   | C CAP.    | 1000pF 250V       | Z     |
| C1912            | QCZ0340-222   | C CAP.    | 2200pF            |       |
| C1913            | QFLC1HJ-471Z  | M CAP.    | 470pF 50V         | J     |
| C1914            | QETN1HM-107Z  | E CAP.    | 100μF 50V         | M     |
| C1916            | NDC31HJ-331X  | C CAP.    | 330pF 50V         | J     |
| C1917            | NCB21HK-122X  | C CAP.    | 1200pF 50V        | K     |
| C1918            | NCB21HK-104X  | C CAP.    | 0.1μF 50V         | K     |
| C1919            | QFP32GJ-103   | PP CAP.   | 0.01μF 400V       | J     |
| C1925            | NRSA63J-0R0X  | MG R      | 0.0Ω 1/16W        | J     |

| △                  | Symbol No. | Part No.       | Part Name       | Description | Local  | △                 | Symbol No. | Part No.        | Part Name        | Description   | Local |
|--------------------|------------|----------------|-----------------|-------------|--------|-------------------|------------|-----------------|------------------|---------------|-------|
| <b>CAPACITOR</b>   |            |                |                 |             |        | <b>DIODE</b>      |            |                 |                  |               |       |
|                    | C1931      | QEZO203-107    | E CAP.          | 100μF 160V  | M      |                   | D1722      | 1SS133-T2       | SI.DIODE         |               |       |
|                    | C1932      | QETN1CM-108Z   | E CAP.          | 1000μF 16V  | M      |                   | D1723-24   | MTZJ5.6B-T2     | ZENER DIODE      |               |       |
|                    | C1933      | QETM1EM-228    | E CAP.          | 2200μF 25V  | M      |                   | D1800      | 1SS81-T2        | SI.DIODE         |               |       |
|                    | C1935      | QETN1EM-108Z   | E CAP.          | 1000μF 25V  | M      |                   | D1801      | 1SS133-T2       | SI.DIODE         |               |       |
|                    | C1937      | QCZO340-102    | C CAP.          | 1000pF      |        |                   | D1810      | MTZJ8.2C-T2     | ZENER DIODE      |               |       |
|                    | C1938      | QETM1EM-228    | E CAP.          | 2200μF 25V  | M      |                   | D1811      | 1SS133-T2       | SI.DIODE         |               |       |
|                    | C1939      | QCB32HK-152Z   | C CAP.          | 1500pF      | 500V K | △                 | D1901      | D3SBA60         | DIODE BRIDGE     |               |       |
|                    | C1941      | QCB32HK-102Z   | C CAP.          | 1000pF      | 500V K |                   | D1910      | MA700A-T2       | SI.DIODE         |               |       |
|                    | C1942      | QEHR1HM-105Z   | E CAP.          | 1μF         | 50V M  | △                 | D1911-13   | RGP10J-5025-T3  | SI.DIODE         |               |       |
|                    | C1943      | QETN1CM-108Z   | E CAP.          | 1000μF      | 16V M  |                   | D1914      | 1SS133-T2       | SI.DIODE         |               |       |
|                    | C1948      | QETN1EM-476Z   | E CAP.          | 47μF        | 25V M  |                   | D1915      | SARS01-T2       | SI.DIODE         |               |       |
|                    | C1951      | QETN1CM-477Z   | E CAP.          | 470μF       | 16V M  |                   | D1917      | MTZJ30A-T2      | ZENER DIODE      |               |       |
|                    | C1971      | QETN1CM-107Z   | E CAP.          | 100μF       | 16V M  |                   | D1918      | MTZJ5.1C-T2     | ZENER DIODE      |               |       |
|                    | C1972      | QETN1EM-476Z   | E CAP.          | 47μF        | 25V M  |                   | D1920      | 1SS133-T2       | SI.DIODE         |               |       |
|                    | C1973      | QETN1HM-106Z   | E CAP.          | 10μF        | 50V M  |                   | D1931      | RU30A-F1        | SI.DIODE         |               |       |
| △                  | C1998-99   | QCZ9074-103    | C CAP.          | 0.01μF      | 125V M |                   | D1933      | RU3YX-LFC4      | SI.DIODE         |               |       |
| <b>TRANSFORMER</b> |            |                |                 |             |        | <b>TRANSISTOR</b> |            |                 |                  |               |       |
|                    | T1501      | CE42034-002    | H.DRIVE TRANSF. |             |        |                   | D1935      | RU3YX-LFC4      | SI.DIODE         |               |       |
| △                  | T1502      | QQH0092-001    | H.V.TRANSF.     |             |        |                   | D1937      | RGP10J-5025-T3  | SI.DIODE         |               |       |
| △                  | T1921      | QQS0098-001    | SWITCH.TRANSF.  |             |        |                   | D1941      | MTZJ33A-T2      | ZENER DIODE      |               |       |
| △                  | T1951      | QQT0315-001    | POWER TRANSF.   |             |        |                   | D1945      | 1SS133-T2       | SI.DIODE         |               |       |
| <b>COIL</b>        |            |                |                 |             |        | <b>TRANSISTOR</b> |            |                 |                  |               |       |
| △                  | L1001      | QQL244K-560Z   | PEAKING COIL    | 56μH        | K      |                   | Q1011      | 2SC5083/L-P/-T  | SI.TRANSISTOR    |               |       |
|                    | L1012      | QQLZ014-R39    | PEAKING COIL    | 0.39μH      |        |                   | Q1021      | 2SC2412K/QR/-X  | SI.TRANSISTOR    |               |       |
|                    | L1021      | QRN143J-0R0X   | C R             | 0.0Ω        | 1/4W J |                   | Q1024      | 2SC2412K/QR/-X  | SI.TRANSISTOR    |               |       |
|                    | L1022      | QQL244K-220Z   | PEAKING COIL    | 22μH        | K      |                   | Q1025      | 2SA1037AK/QR/-X | SI.TRANSISTOR    |               |       |
|                    | L1027      | QRN143J-0R0X   | C R             | 0.0Ω        | 1/4W J |                   | Q1041      | 2SA1037AK/QR/-X | SI.TRANSISTOR    |               |       |
|                    | L1041      | QRN143J-0R0X   | C R             | 0.0Ω        | 1/4W J |                   | Q1131      | 2SC2412K/QR/-X  | SI.TRANSISTOR    |               |       |
|                    | L1042      | QQL244K-220Z   | PEAKING COIL    | 22μH        | K      |                   | Q1232-33   | 2SC2412K/QR/-X  | SI.TRANSISTOR    |               |       |
|                    | L1101      | QQL244K-470Z   | COIL            | 47μH        | K      |                   | Q1352      | 2SC2412K/QR/-X  | SI.TRANSISTOR    |               |       |
|                    | L1232      | QQL244K-560Z   | PEAKING COIL    | 56μH        | K      |                   | Q1431      | 2SC2412K/QR/-X  | SI.TRANSISTOR    |               |       |
| △                  | L1511      | QQR1027-003    | LINE FILTER     |             |        |                   | Q1501      | 2SC4212/Z1/     | SI.TRANSISTOR    |               |       |
|                    | L1512      | QQLZ027-821    | CHOKE COIL      | 820μH       |        |                   | △          | Q1511           | 2SD2559-LB       | SI.TRANSISTOR |       |
| △                  | L1521      | QQLZ026-430    | HEATER CHOKE    | 43μH        |        |                   | Q1531      | 2SC2785/JH/-T   | SI.TRANSISTOR    |               |       |
|                    | L1700      | QQL244K-4R7Z   | COIL            | 4.7μH       | K      |                   | Q1532      | 2SA1037AK/QR/-X | SI.TRANSISTOR    |               |       |
|                    | L1810      | QQL244J-100Z   | COIL            | 10μH        | J      |                   | Q1541-42   | 2SA1037AK/QR/-X | SI.TRANSISTOR    |               |       |
|                    | L1931      | QQL26AK-470Z   | COIL            | 47μH        | K      |                   | △          | Q1543           | 2SD1408/OY/-LB   | SI.TRANSISTOR |       |
|                    | L1933      | QQL26AK-470Z   | COIL            | 47μH        | K      |                   | Q1700      | 2SC2412K/QR/-X  | SI.TRANSISTOR    |               |       |
|                    | L1937      | QQL26AK-470Z   | COIL            | 47μH        | K      |                   | Q1701      | 2SA1037AK/QR/-X | SI.TRANSISTOR    |               |       |
| <b>DIODE</b>       |            |                |                 |             |        | <b>IC</b>         |            |                 |                  |               |       |
|                    | D1101-02   | MTZJ8.2C-T2    | ZENER DIODE     |             |        |                   | IC1101     | TB1253AN        | I.C.(M)          |               |       |
|                    | D1305      | 1SS133-T2      | SI.DIODE        |             |        | △                 | IC1401     | LA7841          | I.C.(MONO-ANA)   |               |       |
|                    | D1306      | 1SS133-T2      | SI.DIODE        |             |        |                   | IC1701     | MN1876478JL1    | I.C.(MICRO-COMP) |               |       |
|                    | D1307      | 1SS133-T2      | SI.DIODE        |             |        |                   | IC1702     | AT24C04-32D502  | I.C.(MEMORY-OTH) | (SERVICE)     |       |
|                    | D1308      | 1SS133-T2      | SI.DIODE        |             |        |                   | IC1703     | MM1437AF-X      | I.C.(MONO-ANA)   |               |       |
|                    | D1309      | 1SS133-T2      | SI.DIODE        |             |        |                   | IC1852     | AN7809F         | I.C.(MONO-ANA)   |               |       |
|                    | D1310      | 1SS133-T2      | SI.DIODE        |             |        |                   | IC1853     | AN7805F         | I.C.(MONO-ANA)   |               |       |
|                    | D1352      | MTZJ9.1C-T2    | ZENER DIODE     |             |        |                   | IC1911     | STR-G6624/F8    | I.C.(HYBRID)     |               |       |
|                    | D1353      | 1SS133-T2      | SI.DIODE        |             |        | △                 | IC1921     | SE135N          | I.C.(HYBRID)     |               |       |
|                    | D1401      | 1SR35-400A-T2  | SI.DIODE        |             |        | <b>OTHERS</b>     |            |                 |                  |               |       |
|                    | D1431      | 1SR35-400A-T2  | SI.DIODE        |             |        |                   | CF1001     | QAX0349-001     | CERAMIC FILTER   |               |       |
|                    | D1432      | 1SS133-T2      | SI.DIODE        |             |        |                   | CF1021     | QAX0639-001Z    | CERAMIC FILTER   |               |       |
|                    | D1501      | RH3G-F1        | SI.DIODE        |             |        |                   | CF1041     | QAX0642-001Z    | CERAMIC FILTER   |               |       |
|                    | D1502      | RU3AM-LFC4     | SI.DIODE        |             |        |                   | △          | CP1932-33       | ICP-N75-Y        | I.C.PROTECT   |       |
|                    | D1521      | RH1S-T3        | SI.DIODE        |             |        |                   | △          | CP1936          | ICP-N75-Y        | I.C.PROTECT   |       |
|                    | D1523-24   | RGP10J-5025-T3 | SI.DIODE        |             |        |                   | △          | F1905           | QMFZ034-5R0Z-J1  | FUSE          | 5A    |
|                    | D1525-26   | 1SS81-T5       | SI.DIODE        |             |        |                   |            |                 |                  |               |       |
|                    | D1527      | 1SR124-400A-T2 | SI.DIODE        |             |        |                   |            |                 |                  |               |       |
|                    | D1529      | MTZJ5.1C-T2    | ZENER DIODE     |             |        |                   |            |                 |                  |               |       |
| △                  | D1531      | MA4068N/Z1/-T2 | ZENER DIODE     |             |        |                   |            |                 |                  |               |       |
|                    | D1535      | 1SS133-T2      | SI.DIODE        |             |        |                   |            |                 |                  |               |       |
|                    | D1537      | 1SR35-400A-T2  | SI.DIODE        |             |        |                   |            |                 |                  |               |       |
|                    | D1601      | MTZJ9.1C-T2    | ZENER DIODE     |             |        |                   |            |                 |                  |               |       |
|                    | D1603      | MTZJ9.1C-T2    | ZENER DIODE     |             |        |                   |            |                 |                  |               |       |
|                    | D1606      | MTZJ9.1C-T2    | ZENER DIODE     |             |        |                   |            |                 |                  |               |       |
|                    | D1701      | 1SS133-T2      | SI.DIODE        |             |        |                   |            |                 |                  |               |       |
|                    | D1706-10   | MTZJ8.2C-T2    | ZENER DIODE     |             |        |                   |            |                 |                  |               |       |
|                    | D1721      | 1SS133-T2      | SI.DIODE        |             |        |                   |            |                 |                  |               |       |

## FRONT CONTROL PW BOARD ASS'Y (SAC-8506A-M2)

| △ Symbol No.  | Part No.       | Part Name        | Description | Local |
|---------------|----------------|------------------|-------------|-------|
| <b>OTHERS</b> |                |                  |             |       |
| △ FR1521      | QRK126J-150X   | C R              | 15Ω 1/2W J  |       |
| △ FR1523-24   | QRX029J-3R3    | MF R             | 3.3Ω 2W J   |       |
| △ FR1525      | QRZ9017-4R7    | F R              | 4.7Ω 1/4W J |       |
| J1601         | QNN0349-002    | PIN JACK         |             |       |
| J1810         | QNS0001-001    | JACK             |             |       |
| K1401         | QQR0621-002Z   | BEADS CORE       |             |       |
| K1912         | QQR0582-001Z   | BEADS CORE       |             |       |
| K1916-17      | QQR0582-001Z   | BEADS CORE       |             |       |
| K1931-33      | QQR0582-001Z   | BEADS CORE       |             |       |
| K1935         | QQR0582-001Z   | BEADS CORE       |             |       |
| K1937         | QQR0582-001Z   | BEADS CORE       |             |       |
| K1940         | QQR0582-001Z   | BEADS CORE       |             |       |
| K1941         | QQR0621-002Z   | BEADS CORE       |             |       |
| LC1601-03     | NQR0169-001X   | EMI FILTER       |             |       |
| △ PC1921      | TLP421F/D4-GF/ | I.C.(PH.COUPLER) |             |       |
| △ RY1941      | QSK0120-001    | RELAY            |             |       |
| △ RY1951      | QSK0113-001    | RELAY            |             |       |
| SF1011        | QAX0324-002    | SAW FILTER       |             |       |
| △ TH1901      | QAD0129-3R0    | P.THERMISTOR     |             |       |
| △ TU1001      | QAU0234-001    | TUNER            |             |       |
| X1201         | CE40668-001Z   | CRYSTAL          |             |       |
| X1700         | QAX0307-001    | CER.RESONATOR    |             |       |

## CRT SOCKET PW BOARD ASS'Y (SAC-3504A-M2)

| △ Symbol No.    | Part No.     | Part Name | Description   | Local |
|-----------------|--------------|-----------|---------------|-------|
| <b>RESISTOR</b> |              |           |               |       |
| R3354-56        | NRSA63J-221X | MG R      | 220Ω 1/16W J  |       |
| R3357-59        | NRSA63J-101X | MG R      | 100Ω 1/16W J  |       |
| R3360-62        | QRZ0111-152  | C R       | 1.5kΩ 1/2W K  |       |
| R3363-65        | QRG029J-103  | OM R      | 10kΩ 2W J     |       |
| R3366-68        | NRSA63J-182X | MG R      | 1.8kΩ 1/16W J |       |
| R3372-74        | NRSA63J-221X | MG R      | 220Ω 1/16W J  |       |
| R3375-77        | NRSA63J-0R0X | MG R      | 0.0Ω 1/16W J  |       |
| R3381           | QRE121J-394Y | C R       | 390kΩ 1/2W J  |       |
| R3391           | NRSA63J-152X | MG R      | 1.5kΩ 1/16W J |       |
| R3392           | NRSA63J-392X | MG R      | 3.9kΩ 1/16W J |       |
| R3393-95        | NRSA63J-102X | MG R      | 1kΩ 1/16W J   |       |

## CAPACITOR

|          |              |        |               |  |
|----------|--------------|--------|---------------|--|
| C3354-55 | NDC31HJ-331X | C CAP. | 330pF 50V J   |  |
| C3356    | NDC31HJ-391X | C CAP. | 390pF 50V J   |  |
| C3357    | QETN1CM-107Z | E CAP. | 100μF 16V M   |  |
| C3382    | QCZ0121-102  | C CAP. | 1000pF 300V Z |  |
| C3391    | QETN1AM-227Z | E CAP. | 220μF 10V M   |  |
| C3392    | NDC31HJ-101X | C CAP. | 100pF 50V J   |  |

## COIL

|       |              |              |       |   |
|-------|--------------|--------------|-------|---|
| L3381 | QQL244K-101Z | PEAKING COIL | 100μH | K |
|-------|--------------|--------------|-------|---|

## DIODE

|       |           |          |  |  |
|-------|-----------|----------|--|--|
| D3391 | 1SS133-T2 | SI.DIODE |  |  |
|-------|-----------|----------|--|--|

## TRANSISTOR

|          |               |               |  |  |
|----------|---------------|---------------|--|--|
| Q3351-53 | 2SC4544-LB    | SI.TRANSISTOR |  |  |
| Q3391    | 2SA933AS/QR-T | SI.TRANSISTOR |  |  |

## OTHERS

|          |             |              |  |  |
|----------|-------------|--------------|--|--|
| △ SK3351 | QNZ0464-001 | C.R.T.SOCKET |  |  |
|----------|-------------|--------------|--|--|

| △ Symbol No.    | Part No.     | Part Name | Description   | Local |
|-----------------|--------------|-----------|---------------|-------|
| <b>RESISTOR</b> |              |           |               |       |
| R8702           | NRSA63J-472X | MG R      | 4.7kΩ 1/16W J |       |
| R8703           | NRSA63J-153X | MG R      | 15kΩ 1/16W J  |       |
| R8705           | NRSA63J-472X | MG R      | 4.7kΩ 1/16W J |       |
| R8706           | NRSA63J-153X | MG R      | 15kΩ 1/16W J  |       |
| R8707           | NRSA63J-222X | MG R      | 2.2kΩ 1/16W J |       |
| R8708           | NRSA63J-681X | MG R      | 680Ω 1/16W J  |       |
| R8709           | NRSA63J-561X | MG R      | 560Ω 1/16W J  |       |

## CAPACITOR

|       |              |        |            |  |
|-------|--------------|--------|------------|--|
| C8701 | QETN1EM-476Z | E CAP. | 47μF 25V M |  |
|-------|--------------|--------|------------|--|

## DIODE

|       |        |             |  |  |
|-------|--------|-------------|--|--|
| D8701 | GL2PR6 | L.E.D.(RED) |  |  |
|-------|--------|-------------|--|--|

## TRANSISTOR

|          |             |                 |  |  |
|----------|-------------|-----------------|--|--|
| Q8701-02 | DTA124EKA-X | DIGI.TRANSISTOR |  |  |
|----------|-------------|-----------------|--|--|

## IC

|        |             |                 |  |  |
|--------|-------------|-----------------|--|--|
| IC8701 | PIC-28143SY | IFR DETECT UNIT |  |  |
|--------|-------------|-----------------|--|--|

## OTHERS

|       |               |              |       |  |
|-------|---------------|--------------|-------|--|
|       | CM46978-A01-H | L.E.D.HOLDER |       |  |
| S8701 | QSW0707-001Z  | TACT SWITCH  | POWER |  |
| S8702 | QSW0707-001Z  | TACT SWITCH  | MENU  |  |
| S8703 | QSW0707-001Z  | TACT SWITCH  | CH-   |  |
| S8704 | QSW0707-001Z  | TACT SWITCH  | CH+   |  |
| S8705 | QSW0707-001Z  | TACT SWITCH  | VOL-  |  |
| S8706 | QSW0707-001Z  | TACT SWITCH  | VOL+  |  |

## FRONT AV INPUT PW BOARD ASS'Y (SAC-8604A-M2)

| △ Symbol No.    | Part No.     | Part Name | Description   | Local |
|-----------------|--------------|-----------|---------------|-------|
| <b>RESISTOR</b> |              |           |               |       |
| R8401           | NRSA63J-750X | MG R      | 75Ω 1/16W J   |       |
| R8402-03        | NRSA63J-224X | MG R      | 220kΩ 1/16W J |       |

## CAPACITOR

|          |              |        |              |  |
|----------|--------------|--------|--------------|--|
| C8401    | QETN1HM-474Z | E CAP. | 0.47μF 50V M |  |
| C8402-03 | QETN1HM-105Z | E CAP. | 1μF 50V M    |  |

## OTHERS

|        |             |          |  |  |
|--------|-------------|----------|--|--|
| J8401  | CEMN041-001 | PIN JACK |  |  |
| LC8401 | QQR1199-001 | FILTER   |  |  |

## LF PW BOARD ASS'Y (SAC-9502A-M2)

| △                | Symbol No. | Part No.       | Part Name   | Description  | Local |
|------------------|------------|----------------|-------------|--------------|-------|
| <b>RESISTOR</b>  |            |                |             |              |       |
|                  | R9997      | QRE121J-5R6Y   | C R         | 5.6Ω 1/2W J  |       |
| △                | R9998      | QRZ9041-275    | C R         | 2.7MΩ 1/2W K |       |
| <b>CAPACITOR</b> |            |                |             |              |       |
| △                | C9901      | QFZ9067-104    | MM CAP.     | 0.1μF        |       |
| △                | C9902      | QFZ9067-473    | MM CAP.     | 0.047μF      |       |
| △                | C9904      | QCZ9052-102    | C CAP.      | 1000pF       |       |
| <b>OTHERS</b>    |            |                |             |              |       |
| △                | CN90PW     | QMPD200-200-JC | POWER CORD  |              |       |
| △                | F9901      | QMF0007-5R0J1  | FUSE        | 5A           |       |
|                  | FC9901     | CEMG002-001Z   | FUSE CLIP   |              |       |
| △                | LF9902     | QQR0527-003    | LINE FILTER |              |       |
| △                | VA9901     | ERZV10V621CS   | VARISTOR    |              |       |

## PIP PW BOARD ASS'Y (SAC0P502A-M2)

| △                | Symbol No. | Part No.     | Part Name | Description   | Local |
|------------------|------------|--------------|-----------|---------------|-------|
| <b>RESISTOR</b>  |            |              |           |               |       |
|                  | R0001-02   | NRSA63J-103X | MG R      | 10kΩ 1/16W J  |       |
|                  | R0003-04   | NRSA63J-101X | MG R      | 100Ω 1/16W J  |       |
|                  | R0005      | NRSA63J-0R0X | MG R      | 0.0Ω 1/16W J  |       |
|                  | R0011      | NRSA63J-0R0X | MG R      | 0.0Ω 1/16W J  |       |
|                  | R0121      | NRSA63J-0R0X | MG R      | 0.0Ω 1/16W J  |       |
|                  | R0301      | NRSA63J-473X | MG R      | 47kΩ 1/16W J  |       |
|                  | R0303      | NRSA63J-222X | MG R      | 2.2kΩ 1/16W J |       |
|                  | R0304      | NRSA63J-473X | MG R      | 47kΩ 1/16W J  |       |
|                  | R0306      | NRSA63J-222X | MG R      | 2.2kΩ 1/16W J |       |
|                  | R0307-08   | NRSA63J-332X | MG R      | 3.3kΩ 1/16W J |       |
|                  | R0309      | NRSA63J-102X | MG R      | 1kΩ 1/16W J   |       |
|                  | R0311      | NRSA63J-101X | MG R      | 100Ω 1/16W J  |       |
|                  | R0313      | NRSA63J-101X | MG R      | 100Ω 1/16W J  |       |
|                  | R0314      | NRSA63J-0R0X | MG R      | 0.0Ω 1/16W J  |       |
|                  | R0316      | NRSA63J-331X | MG R      | 330Ω 1/16W J  |       |
|                  | R0317      | NRSA63J-0R0X | MG R      | 0.0Ω 1/16W J  |       |
|                  | R0331      | NRSA63J-0R0X | MG R      | 0.0Ω 1/16W J  |       |
|                  | R0337      | NRSA63J-0R0X | MG R      | 0.0Ω 1/16W J  |       |
|                  | R0343      | NRSA63J-0R0X | MG R      | 0.0Ω 1/16W J  |       |
| <b>CAPACITOR</b> |            |              |           |               |       |
|                  | C0003-04   | QETN1HM-106Z | E CAP.    | 10μF 50V M    |       |
|                  | C0006      | QETN1HM-106Z | E CAP.    | 10μF 50V M    |       |
|                  | C0008      | QETN1EM-476Z | E CAP.    | 47μF 25V M    |       |
|                  | C0301-02   | NRSA63J-0R0X | MG R      | 0.0Ω 1/16W J  |       |
|                  | C0312-13   | NDC31HJ-270X | C CAP.    | 27pF 50V J    |       |
|                  | C0314      | QETN1HM-106Z | E CAP.    | 10μF 50V M    |       |
|                  | C0315      | NCB31HK-103X | C CAP.    | 0.01μF 50V K  |       |
|                  | C0316-18   | NCB21HK-104X | C CAP.    | 0.1μF 50V K   |       |
|                  | C0319      | QETN1HM-106Z | E CAP.    | 10μF 50V M    |       |
|                  | C0320      | NCB31HK-103X | C CAP.    | 0.01μF 50V K  |       |
|                  | C0321      | QETN1HM-105Z | E CAP.    | 1μF 50V M     |       |
|                  | C0322      | NCB31HK-103X | C CAP.    | 0.01μF 50V K  |       |
|                  | C0323      | QETN1HM-106Z | E CAP.    | 10μF 50V M    |       |
|                  | C0324-25   | NCB31HK-103X | C CAP.    | 0.01μF 50V K  |       |
|                  | C0326      | NCB21HK-104X | C CAP.    | 0.1μF 50V K   |       |
|                  | C0327      | QETN1HM-225Z | E CAP.    | 2.2μF 50V M   |       |
|                  | C0328      | NCB31HK-103X | C CAP.    | 0.01μF 50V K  |       |
|                  | C0329      | QETN1HM-225Z | E CAP.    | 2.2μF 50V M   |       |
|                  | C0330      | NCB31HK-103X | C CAP.    | 0.01μF 50V K  |       |

| △                 | Symbol No. | Part No.       | Part Name      | Description | Local |
|-------------------|------------|----------------|----------------|-------------|-------|
| <b>CAPACITOR</b>  |            |                |                |             |       |
|                   | C0331      | NCB21HK-104X   | C CAP.         | 0.1μF 50V K |       |
| <b>COIL</b>       |            |                |                |             |       |
|                   | L0302-04   | QQL244J-6R8Z   | COIL           | 6.8μH J     |       |
| <b>DIODE</b>      |            |                |                |             |       |
|                   | D0301      | 1SS133-T2      | SI.DIODE       |             |       |
| <b>TRANSISTOR</b> |            |                |                |             |       |
|                   | Q0301-03   | 2SC2412K/QR/-X | SI.TRANSISTOR  |             |       |
| <b>IC</b>         |            |                |                |             |       |
|                   | IC0001     | AN7805F        | I.C.(MONO-ANA) |             |       |
|                   | IC0301     | SDA9389X-X     | I.C.(DIGI-MOS) |             |       |
| <b>OTHERS</b>     |            |                |                |             |       |
| △                 | TU0001     | QAU0206-001    | TUNER          |             |       |
|                   | X0301      | QAX0521-001Z   | CRYSTAL        |             |       |

## AV SELECTOR PW BOARD ASS'Y (SAC0S509A-M2)

| △               | Symbol No. | Part No.     | Part Name | Description   | Local |
|-----------------|------------|--------------|-----------|---------------|-------|
| <b>RESISTOR</b> |            |              |           |               |       |
|                 | R0081      | NRSA63J-102X | MG R      | 1kΩ 1/16W J   |       |
|                 | R0082      | NRSA63J-682X | MG R      | 6.8kΩ 1/16W J |       |
|                 | R0083      | NRSA63J-153X | MG R      | 15kΩ 1/16W J  |       |
|                 | R0084      | NRSA63J-683X | MG R      | 68kΩ 1/16W J  |       |
|                 | R0085      | NRSA63J-332X | MG R      | 3.3kΩ 1/16W J |       |
|                 | R0086      | NRSA63J-333X | MG R      | 33kΩ 1/16W J  |       |
|                 | R0087      | NRSA63J-153X | MG R      | 15kΩ 1/16W J  |       |
|                 | R0088      | NRSA63J-152X | MG R      | 1.5kΩ 1/16W J |       |
|                 | R0089      | NRSA63J-562X | MG R      | 5.6kΩ 1/16W J |       |
|                 | R0090      | NRSA63J-563X | MG R      | 56kΩ 1/16W J  |       |
|                 | R0202      | NRSA63J-101X | MG R      | 100Ω 1/16W J  |       |
|                 | R0210      | NRSA63J-0R0X | MG R      | 0.0Ω 1/16W J  |       |
|                 | R0211      | NRSA63J-153X | MG R      | 15kΩ 1/16W J  |       |
|                 | R0212      | NRSA63J-333X | MG R      | 33kΩ 1/16W J  |       |
|                 | R0213      | NRSA63J-102X | MG R      | 1kΩ 1/16W J   |       |
|                 | R0214      | NRSA63J-181X | MG R      | 180Ω 1/16W J  |       |
|                 | R0215      | NRSA63J-152X | MG R      | 1.5kΩ 1/16W J |       |
|                 | R0216      | NRSA63J-182X | MG R      | 1.8kΩ 1/16W J |       |
|                 | R0217      | NRSA63J-102X | MG R      | 1kΩ 1/16W J   |       |
|                 | R0218      | NRSA63J-222X | MG R      | 2.2kΩ 1/16W J |       |
|                 | R0223      | NRSA63J-0R0X | MG R      | 0.0Ω 1/16W J  |       |
|                 | R0229      | NRSA63J-473X | MG R      | 47kΩ 1/16W J  |       |
|                 | R0230      | NRSA63J-223X | MG R      | 22kΩ 1/16W J  |       |
|                 | R0231      | NRSA63J-101X | MG R      | 100Ω 1/16W J  |       |
|                 | R0232      | NRSA63J-102X | MG R      | 1kΩ 1/16W J   |       |
|                 | R0233      | NRSA63J-272X | MG R      | 2.7kΩ 1/16W J |       |
|                 | R0234      | NRSA63J-102X | MG R      | 1kΩ 1/16W J   |       |
|                 | R0235-36   | NRSA63J-101X | MG R      | 100Ω 1/16W J  |       |
|                 | R0238      | NRSA63J-822X | MG R      | 8.2kΩ 1/16W J |       |
|                 | R0239      | NRSA63J-123X | MG R      | 12kΩ 1/16W J  |       |
|                 | R0241      | NRSA63J-821X | MG R      | 820Ω 1/16W J  |       |
|                 | R0242      | NRSA63J-474X | MG R      | 470kΩ 1/16W J |       |

| △ Symbol No.    | Part No.     | Part Name | Description   | Local |
|-----------------|--------------|-----------|---------------|-------|
| <b>RESISTOR</b> |              |           |               |       |
| R0243-44        | NRSA63J-103X | MG R      | 10kΩ 1/16W J  |       |
| R0247           | NRSA63J-101X | MG R      | 100Ω 1/16W J  |       |
| R0251           | NRSA63J-471X | MG R      | 470Ω 1/16W J  |       |
| R0253           | NRSA63J-681X | MG R      | 680Ω 1/16W J  |       |
| R0254           | NRSA63J-391X | MG R      | 390Ω 1/16W J  |       |
| R0255           | NRSA63J-681X | MG R      | 680Ω 1/16W J  |       |
| R0258           | NRSA63J-101X | MG R      | 100Ω 1/16W J  |       |
| R0259           | NRSA63J-222X | MG R      | 2.2kΩ 1/16W J |       |
| R0261           | NRSA63J-101X | MG R      | 100Ω 1/16W J  |       |
| R0262           | NRSA63J-222X | MG R      | 2.2kΩ 1/16W J |       |
| R0263           | NRSA63J-471X | MG R      | 470Ω 1/16W J  |       |
| R0265           | NRSA63J-102X | MG R      | 1kΩ 1/16W J   |       |
| R0269           | NRSA63J-681X | MG R      | 680Ω 1/16W J  |       |
| R0270           | NRSA63J-820X | MG R      | 82Ω 1/16W J   |       |
| R0301-02        | NRSA63J-222X | MG R      | 2.2kΩ 1/16W J |       |
| R0303-04        | NRSA63J-221X | MG R      | 220Ω 1/16W J  |       |
| R0305-06        | NRSA63J-0R0X | MG R      | 0.0Ω 1/16W J  |       |
| R0331-34        | NRSA63J-101X | MG R      | 100Ω 1/16W J  |       |
| R0371-74        | NRSA63J-103X | MG R      | 10kΩ 1/16W J  |       |
| R0375-76        | NRSA63J-333X | MG R      | 33kΩ 1/16W J  |       |
| R0377-78        | NRSA63J-472X | MG R      | 4.7kΩ 1/16W J |       |
| R0385           | NRSA63J-223X | MG R      | 22kΩ 1/16W J  |       |
| R0387           | NRSA63J-223X | MG R      | 22kΩ 1/16W J  |       |
| R0391-92        | NRSA63J-221X | MG R      | 220Ω 1/16W J  |       |
| R0393-94        | NRSA63J-823X | MG R      | 82kΩ 1/16W J  |       |
| R0395-96        | NRSA63J-221X | MG R      | 220Ω 1/16W J  |       |
| R0401           | NRSA63J-183X | MG R      | 18kΩ 1/16W J  |       |
| R0402           | NRSA63J-223X | MG R      | 22kΩ 1/16W J  |       |
| R0458           | NRSA63J-333X | MG R      | 33kΩ 1/16W J  |       |
| R0459           | NRSA63J-183X | MG R      | 18kΩ 1/16W J  |       |
| R0501-02        | NRSA63J-102X | MG R      | 1kΩ 1/16W J   |       |
| R0504-05        | NRSA63J-102X | MG R      | 1kΩ 1/16W J   |       |
| R0507-08        | NRSA63J-102X | MG R      | 1kΩ 1/16W J   |       |
| R0509           | NRSA63J-221X | MG R      | 220Ω 1/16W J  |       |
| R0518           | NRSA63J-333X | MG R      | 33kΩ 1/16W J  |       |
| R0519-21        | NRSA63J-750X | MG R      | 75Ω 1/16W J   |       |
| R0522-23        | NRSA63J-224X | MG R      | 220kΩ 1/16W J |       |
| R0528-29        | NRSA63J-0R0X | MG R      | 0.0Ω 1/16W J  |       |
| R0532-33        | NRSA63J-224X | MG R      | 220kΩ 1/16W J |       |
| R0558-61        | NRSA63J-0R0X | MG R      | 0.0Ω 1/16W J  |       |
| R0566-67        | NRSA63J-331X | MG R      | 330Ω 1/16W J  |       |
| R0571           | NRSA63J-101X | MG R      | 100Ω 1/16W J  |       |
| R0573           | NRSA63J-272X | MG R      | 2.7kΩ 1/16W J |       |
| R0574           | NRSA63J-0R0X | MG R      | 0.0Ω 1/16W J  |       |
| R0901           | NRSA63J-101X | MG R      | 100Ω 1/16W J  |       |
| R0906           | NRSA63J-0R0X | MG R      | 0.0Ω 1/16W J  |       |

**CAPACITOR**

|          |              |           |               |
|----------|--------------|-----------|---------------|
| C0081    | NCB21HK-104X | C CAP.    | 0.1μF 50V K   |
| C0082    | QENC1HM-475Z | BP E CAP. | 4.7μF 50V M   |
| C0083    | QENC1HM-105Z | BP E CAP. | 1μF 50V M     |
| C0084    | QETN1HM-225Z | E CAP.    | 2.2μF 50V M   |
| C0085    | NCB21HK-473X | C CAP.    | 0.047μF 50V K |
| C0086    | QETN1HM-474Z | E CAP.    | 0.47μF 50V M  |
| C0087-88 | NCB21HK-104X | C CAP.    | 0.1μF 50V K   |
| C0089    | QETN1HM-335Z | E CAP.    | 3.3μF 50V M   |
| C0090    | QETN1HM-105Z | E CAP.    | 1μF 50V M     |
| C0091    | QETN1HM-106Z | E CAP.    | 10μF 50V M    |
| C0092-93 | QETN1HM-105Z | E CAP.    | 1μF 50V M     |
| C0094    | QETN1HM-475Z | E CAP.    | 4.7μF 50V M   |
| C0095    | QETN1HM-105Z | E CAP.    | 1μF 50V M     |
| C0205    | QETN1HM-476Z | E CAP.    | 47μF 50V M    |
| C0206    | NCB31HK-103X | C CAP.    | 0.01μF 50V K  |
| C0211    | QENC1EM-106Z | BP E CAP. | 10μF 25V M    |
| C0212    | NDC31HJ-101X | C CAP.    | 100pF 50V J   |
| C0213    | NDC31HJ-470X | C CAP.    | 47pF 50V J    |
| C0214    | NDC31HJ-181X | C CAP.    | 180pF 50V J   |
| C0215    | QETN1HM-474Z | E CAP.    | 0.47μF 50V M  |
| C0223    | NCB31HK-103X | C CAP.    | 0.01μF 50V K  |
| C0226    | NCB31HK-103X | C CAP.    | 0.01μF 50V K  |
| C0231-33 | QETN1HM-106Z | E CAP.    | 10μF 50V M    |
| C0234    | NCB31HK-103X | C CAP.    | 0.01μF 50V K  |

| △ Symbol No.     | Part No.     | Part Name | Description   | Local |
|------------------|--------------|-----------|---------------|-------|
| <b>CAPACITOR</b> |              |           |               |       |
| C0235            | QETN1HM-106Z | E CAP.    | 10μF 50V M    |       |
| C0236            | NCB31HK-103X | C CAP.    | 0.01μF 50V K  |       |
| C0237            | NCB31HK-472X | C CAP.    | 4700pF 50V K  |       |
| C0238-39         | NCB31HK-103X | C CAP.    | 0.01μF 50V K  |       |
| C0241-45         | NCB31HK-103X | C CAP.    | 0.01μF 50V K  |       |
| C0246            | NDC31HJ-181X | C CAP.    | 180pF 50V J   |       |
| C0247-49         | NCB31HK-103X | C CAP.    | 0.01μF 50V K  |       |
| C0251            | QETN1HM-476Z | E CAP.    | 47μF 50V M    |       |
| C0252            | NCB31HK-103X | C CAP.    | 0.01μF 50V K  |       |
| C0255            | NDC31HJ-390X | C CAP.    | 39pF 50V J    |       |
| C0263            | NDC31HJ-150X | C CAP.    | 15pF 50V J    |       |
| C0264            | QENC1HM-474Z | BP E CAP. | 0.47μF 50V M  |       |
| C0265            | NCB31HK-103X | C CAP.    | 0.01μF 50V K  |       |
| C0309-10         | NCB31HK-102X | C CAP.    | 1000pF 50V K  |       |
| C0311-12         | NRSA63J-0R0X | MG R      | 0.0Ω 1/16W J  |       |
| C0331            | QETN1CM-107Z | E CAP.    | 100μF 16V M   |       |
| C0332            | NCB31HK-103X | C CAP.    | 0.01μF 50V K  |       |
| C0333            | QETN1EM-476Z | E CAP.    | 47μF 25V M    |       |
| C0334            | NCB21HK-273X | C CAP.    | 0.027μF 50V K |       |
| C0335            | QETN1HM-225Z | E CAP.    | 2.2μF 50V M   |       |
| C0336            | NCB31HK-222X | C CAP.    | 2200pF 50V K  |       |
| C0337            | NCB21HK-104X | C CAP.    | 0.1μF 50V K   |       |
| C0338            | QETN1HM-225Z | E CAP.    | 2.2μF 50V M   |       |
| C0339            | NCB31HK-222X | C CAP.    | 2200pF 50V K  |       |
| C0340            | NCB21HK-104X | C CAP.    | 0.1μF 50V K   |       |
| C0343            | QETN1HM-105Z | E CAP.    | 1μF 50V M     |       |
| C0344-45         | QENC1HM-225Z | BP E CAP. | 2.2μF 50V M   |       |
| C0371-72         | QENC1HM-105Z | BP E CAP. | 1μF 50V M     |       |
| C0373            | QETN1EM-476Z | E CAP.    | 47μF 25V M    |       |
| C0391-92         | QETN1HM-474Z | E CAP.    | 0.47μF 50V M  |       |
| C0401            | QETN1CM-107Z | E CAP.    | 100μF 16V M   |       |
| C0402-03         | NCF21CZ-105X | C CAP.    | 1μF 16V Z     |       |
| C0404            | QFV71HJ-224Z | MF CAP.   | 0.22μF 50V J  |       |
| C0407            | QETN1EM-108Z | E CAP.    | 1000pF 25V M  |       |
| C0410-11         | QETN1EM-108Z | E CAP.    | 1000pF 25V M  |       |
| C0412-13         | QETN1HM-105Z | E CAP.    | 1μF 50V M     |       |
| C0501-02         | NCB31HK-103X | C CAP.    | 0.01μF 50V K  |       |
| C0503            | QETN1HM-226Z | E CAP.    | 22μF 50V M    |       |
| C0504            | QETN1EM-476Z | E CAP.    | 47μF 25V M    |       |
| C0505            | QENC1HM-474Z | BP E CAP. | 0.47μF 50V M  |       |
| C0508            | QETN1HM-474Z | E CAP.    | 0.47μF 50V M  |       |
| C0509            | NCB31HK-103X | C CAP.    | 0.01μF 50V K  |       |
| C0511            | QETN1HM-474Z | E CAP.    | 0.47μF 50V M  |       |
| C0512-13         | QETN1HM-105Z | E CAP.    | 1μF 50V M     |       |
| C0520-21         | QETN1HM-105Z | E CAP.    | 1μF 50V M     |       |
| C0531-32         | NCB31HK-103X | C CAP.    | 0.01μF 50V K  |       |
| C0536-39         | NCB31HK-103X | C CAP.    | 0.01μF 50V K  |       |

**COIL**

|          |              |      |         |
|----------|--------------|------|---------|
| L0202    | QLL244K-150Z | COIL | 15μH K  |
| L0211    | QLL244K-4R7Z | COIL | 4.7μH K |
| L0242-43 | QLL244K-4R7Z | COIL | 4.7μH K |
| L0261    | QLL244K-150Z | COIL | 15μH K  |

**DIODE**

|          |            |             |
|----------|------------|-------------|
| D0391-92 | MTZJ10C-T2 | ZENER DIODE |
| D0501-02 | MTZJ10C-T2 | ZENER DIODE |
| D0504    | MTZJ10C-T2 | ZENER DIODE |
| D0509    | MTZJ10C-T2 | ZENER DIODE |
| D0511    | MTZJ10C-T2 | ZENER DIODE |
| D0515-19 | MTZJ10C-T2 | ZENER DIODE |
| D0521    | MTZJ10C-T2 | ZENER DIODE |

**TRANSISTOR**

|          |                 |               |
|----------|-----------------|---------------|
| Q0211-12 | 2SC2412K/QR/-X  | SI.TRANSISTOR |
| Q0218    | 2SC2412K/QR/-X  | SI.TRANSISTOR |
| Q0219    | 2SA1037AK/QR/-X | SI.TRANSISTOR |
| Q0251    | 2SC2412K/QR/-X  | SI.TRANSISTOR |
| Q0252    | 2SA1037AK/QR/-X | SI.TRANSISTOR |
| Q0253    | 2SC2412K/QR/-X  | SI.TRANSISTOR |
| Q0261-62 | 2SC2412K/QR/-X  | SI.TRANSISTOR |

| △ Symbol No.      | Part No.        | Part Name       | Description | Local |
|-------------------|-----------------|-----------------|-------------|-------|
| <b>TRANSISTOR</b> |                 |                 |             |       |
| Q0263             | 2SA1037AK/QR/-X | SI.TRANSISTOR   |             |       |
| Q0301-02          | DTC124EKA-X     | DIGI.TRANSISTOR |             |       |
| Q0385             | DTC323TK-X      | DIGI.TRANSISTOR |             |       |
| Q0387             | DTC323TK-X      | DIGI.TRANSISTOR |             |       |
| Q0453             | 2SC2412K/QR/-X  | SI.TRANSISTOR   |             |       |
| Q0454             | DTC124EKA-X     | DIGI.TRANSISTOR |             |       |
| Q0509             | 2SC2412K/QR/-X  | SI.TRANSISTOR   |             |       |
| <b>IC</b>         |                 |                 |             |       |
| IC0001            | UPC1851BCU      | I.C.(MONO-ANA)  |             |       |
| IC0201            | TC90A53N        | I.C.(DIGI-MOS)  |             |       |
| IC0371            | BA15218N        | I.C.(MONO-ANA)  |             |       |
| IC0401            | LA4485          | I.C.(MONO-ANA)  |             |       |
| IC0501            | CXA2089Q-X      | I.C.(MONO-ANA)  |             |       |
| <b>OTHERS</b>     |                 |                 |             |       |
| J0501             | QNZ0454-001     | PIN JACK        |             |       |
| J0502-03          | QNN0348-001     | PIN JACK        |             |       |

## REMOTE CONTROL UNIT PARTS LIST (RM-C305-1A)

| △ Ref.No. | Part No.    | Part Name     | Description | Local |
|-----------|-------------|---------------|-------------|-------|
|           | UR52EC1286A | BATTERY COVER |             |       |

## DIFFERENCE PARTS LIST BETWEEN AV-36260/R AND AV-36260/H

The picture tubes used for the models AV-36260/R and AV-36260/H are difference. The electrical parts are also difference according to the PICTURE TUBE.

In the DIFFERENCE PARTS LIST BETWEEN AV-36260/R and AV-36260/H, only difference points between these models are written. For other parts not mentioned in the list, please refer to the PARTS LIST(P47 – P53) for the AV-36260/R.

## DIFFERENCE PARTS LIST

### MAIN PWB

| ⚠ | Symbol No. | Part No.                         |                                  | Part Name       |
|---|------------|----------------------------------|----------------------------------|-----------------|
|   |            | AV-36260/R                       | AV-36260/H                       |                 |
|   |            | <b>SAC-1533A-M2</b>              | <b>SAC-1534A-M2</b>              | <b>MAIN PWB</b> |
| ⚠ | C1515      | QFZ0197-624<br>(0.62μF, 250V, J) | QFZ0197-564<br>(0.56μF, 250V, J) | MPP CAP.        |

### CRT SOCKET PWB

| ⚠ | Symbol No. | Part No.            |                     | Part Name             |
|---|------------|---------------------|---------------------|-----------------------|
|   |            | AV-36260/R          | AV-36260/H          |                       |
|   |            | <b>SAC-3504A-M2</b> | <b>SAC-3505A-M2</b> | <b>CRT SOCKET PWB</b> |

### CRT SOCKET PW BOARD ASS'Y (SAC-3505A-M2)

| ⚠                 | Symbol No. | Part No.       | Part Name     | Description  | Local |
|-------------------|------------|----------------|---------------|--------------|-------|
| <b>RESISTOR</b>   |            |                |               |              |       |
|                   | R3354-56   | NRSA63J-221X   | MG R          | 220Ω 1/16W   | J     |
|                   | R3357-59   | NRSA63J-101X   | MG R          | 100Ω 1/16W   | J     |
|                   | R3360-62   | QRZ0111-152    | C R           | 1.5kΩ 1/2W   | K     |
|                   | R3363-65   | QRG029J-103    | OM R          | 10kΩ 2W      | J     |
|                   | R3366-68   | NRSA63J-182X   | MG R          | 1.8kΩ 1/16W  | J     |
|                   | R3372-74   | NRSA63J-221X   | MG R          | 220Ω 1/16W   | J     |
|                   | R3375-77   | NRSA63J-0R0X   | MG R          | 0.0Ω 1/16W   | J     |
|                   | R3381      | QRE121J-394Y   | C R           | 390kΩ 1/2W   | J     |
|                   | R3391      | NRSA63J-152X   | MG R          | 1.5kΩ 1/16W  | J     |
|                   | R3392      | NRSA63J-392X   | MG R          | 3.9kΩ 1/16W  | J     |
|                   | R3393-95   | NRSA63J-102X   | MG R          | 1kΩ 1/16W    | J     |
| <b>CAPACITOR</b>  |            |                |               |              |       |
|                   | C3354-55   | NDC31HJ-331X   | C CAP.        | 330pF 50V    | J     |
|                   | C3356      | NDC31HJ-391X   | C CAP.        | 390pF 50V    | J     |
|                   | C3357      | QETN1CM-107Z   | E CAP.        | 100μF 16V    | M     |
|                   | C3382      | QCZ0121-102    | C CAP.        | 1000pF 3000V | Z     |
|                   | C3391      | QETN1AM-227Z   | E CAP.        | 220μF 10V    | M     |
|                   | C3392      | NDC31HJ-101X   | C CAP.        | 100pF 50V    | J     |
| <b>COIL</b>       |            |                |               |              |       |
|                   | L3381      | QQL244K-101Z   | PEAKING COIL  | 100μH        | K     |
| <b>DIODE</b>      |            |                |               |              |       |
|                   | D3391      | 1SS133-T2      | SI.DIODE      |              |       |
| <b>TRANSISTOR</b> |            |                |               |              |       |
|                   | Q3351-53   | 2SC4544-LB     | SI.TRANSISTOR |              |       |
|                   | Q3391      | 2SA933AS/QR/-T | SI.TRANSISTOR |              |       |
| <b>OTHERS</b>     |            |                |               |              |       |
| ⚠                 | SK3351     | QNZ0464-001    | C.R.T.SOCKET  |              |       |

# PACKING

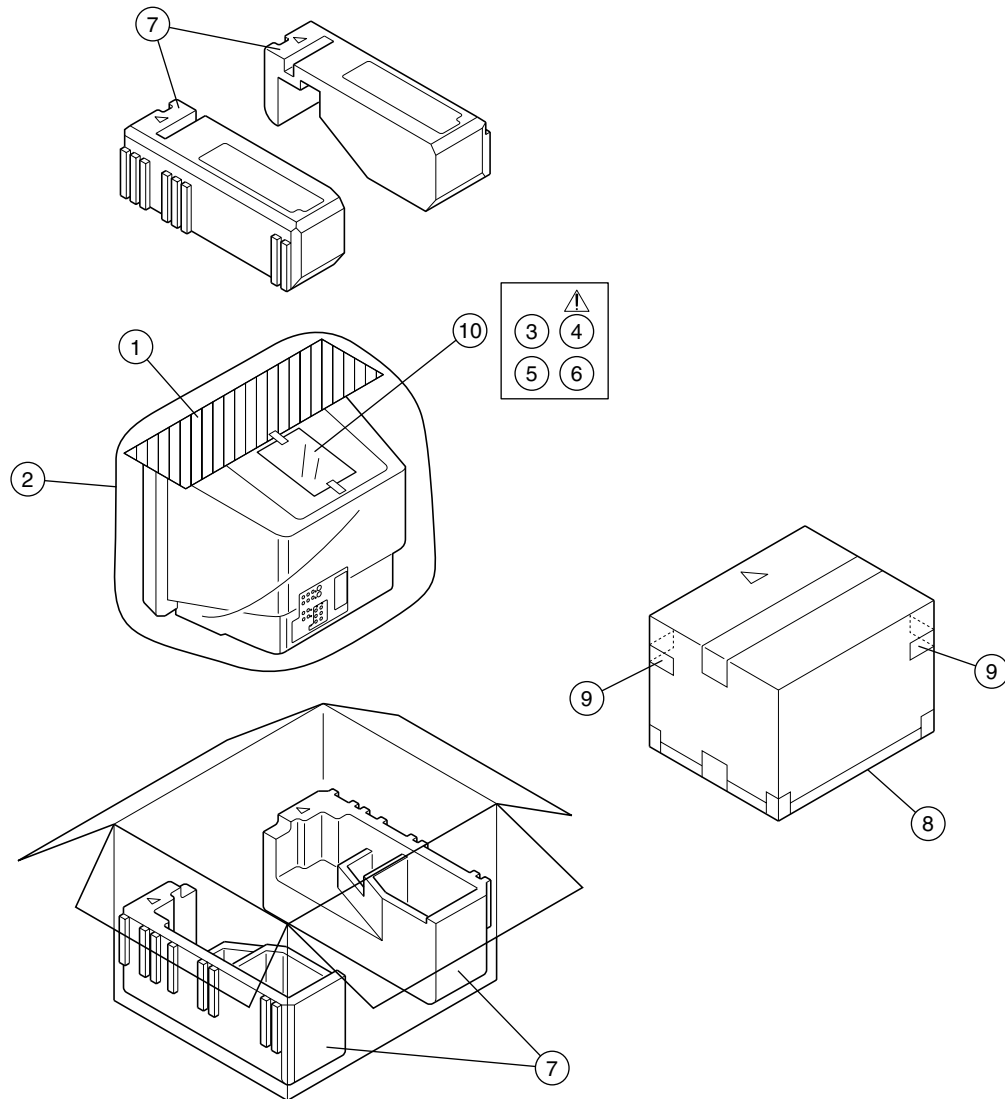

## PACKING PARTS LIST

| △ Ref.No. | Part No.       | Part Name     | Description  | Local |
|-----------|----------------|---------------|--------------|-------|
| 1         | CP30055-A02-A  | TOP COVER     |              |       |
| 2         | CP30056-004-A  | POLY BAG      |              |       |
| 3         | RM-C306-1A     | RC HAND UNIT  | (AV-36230)   |       |
| 3         | RM-C305-1A     | RC HAND UNIT  | (AV-36260)   |       |
| △ 4       | LCT0951-001A-A | INST BOOK     |              |       |
| 5         | BT-51020-1Q    | REGISTER CARD |              |       |
| 6         | BT-52004-1Q    | WARRANTY CARD |              |       |
| 7         | CP11387-A0D-A  | CUSHION ASSY  | 4pcs in 1set |       |
| 8         | LC10181-024A-A | PACKING CASE  |              |       |
| 9         | CM36616-001-A  | CORNER LABEL  | 2pcs in 1set |       |
| 10        | QPA02503505    | POLY BAG      |              |       |

# JVC SERVICE & ENGINEERING COMPANY OF AMERICA

## DIVISION OF JVC AMERICAS CORP.

|                    |   |               |
|--------------------|---|---------------|
| <b>Head office</b> | : 1700 Valley Road, Wayne, New Jersey 07470         | (973)315-5000 |
| <b>East Coast</b>  | : 10 New Maple Avenue, Pine Brook, New Jersey 07058 | (973)396-1000 |
| <b>Midwest</b>     | : 705 Enterprise St. Aurora, Illinois 60504         | (630)851-7855 |
| <b>West Coast</b>  | : 5665 Corporate Avenue, Cypress, California 90630  | (714)229-8011 |
| <b>Southwest</b>   | : 10700 Hammerly, Suite 105, Houston, Texas 77043   | (713)935-9331 |
| <b>Hawaii</b>      | : 2969 Mapunapuna Place, Honolulu, Hawaii 96819     | (808)833-5828 |
| <b>Southeast</b>   | : 1500 Lakes Parkway, Lawrenceville, Georgia 30243  | (770)339-2582 |

## JVC CANADA INC.

|                    |  |               |
|--------------------|--|---------------|
| <b>Head office</b> | : 21 Finchdene Square Scarborough, Ontario M1X 1A7 | (416)293-1311 |
| <b>Vancouver</b>   | : 13040 Worster Court Richmond B.C. V6V 2B3        | (604)270-1311 |

# JVC®