

JVC

SERVICE MANUAL

COLOR TELEVISION

AV-N29304/RA, AV-N29304/SA, AV-N29430/RA, AV-N29430/SA

BASIC CHASSIS
FE2

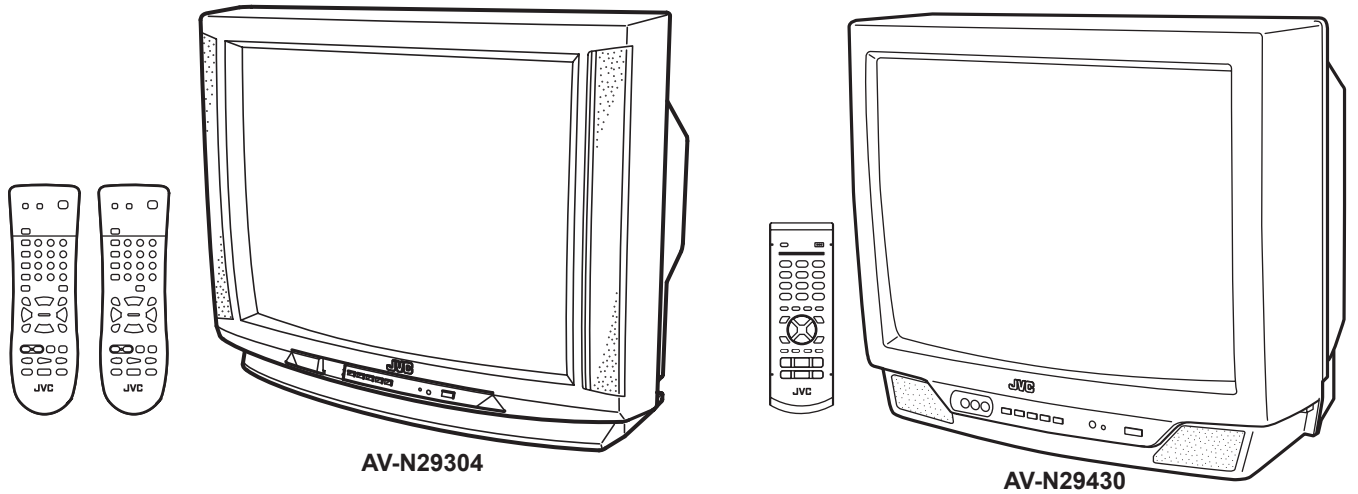

TABLE OF CONTENTS

1	PRECAUTIONS	1-3
2	SPECIFIC SERVICE INSTRUCTIONS	1-4
3	ADJUSTMENT	1-12

SECTION 1 PRECAUTIONS

1.1 SAFETY PRECAUTIONS

- (1) The design of this product contains special hardware, many circuits and components specially for safety purposes. For continued protection, no changes should be made to the original design unless authorized in writing by the manufacturer. Replacement parts must be identical to those used in the original circuits. Service should be performed by qualified personnel only.
- (2) Alterations of the design or circuitry of the products should not be made. Any design alterations or additions will void the manufacturer's warranty and will further relieve the manufacturer of responsibility for personal injury or property damage resulting therefrom.
- (3) Many electrical and mechanical parts in the products have special safety-related characteristics. These characteristics are often not evident from visual inspection nor can the protection afforded by them necessarily be obtained by using replacement components rated for higher voltage, wattage, etc. Replacement parts which have these special safety characteristics are identified in the parts list of Service manual. **Electrical components having such features are identified by shading on the schematics and by (Δ) on the parts list in Service manual.** The use of a substitute replacement which does not have the same safety characteristics as the recommended replacement part shown in the parts list of Service manual may cause shock, fire, or other hazards.
- (4) **Use isolation transformer when hot chassis.**
The chassis and any sub-chassis contained in some products are connected to one side of the AC power line. An isolation transformer of adequate capacity should be inserted between the product and the AC power supply point while performing any service on some products when the HOT chassis is exposed.
- (5) **Don't short between the LIVE side ground and ISOLATED (NEUTRAL) side ground or EARTH side ground when repairing.**
Some model's power circuit is partly different in the GND. The difference of the GND is shown by the LIVE : (\perp) side GND, the ISOLATED (NEUTRAL) : (\equiv) side GND and EARTH : (\oplus) side GND. Don't short between the LIVE side GND and ISOLATED (NEUTRAL) side GND or EARTH side GND and never measure the LIVE side GND and ISOLATED (NEUTRAL) side GND or EARTH side GND at the same time with a measuring apparatus (oscilloscope etc.). If above note will not be kept, a fuse or any parts will be broken.
- (6) If any repair has been made to the chassis, it is recommended that the B1 setting should be checked or adjusted (See ADJUSTMENT OF B1 POWER SUPPLY).
- (7) The high voltage applied to the picture tube must conform with that specified in Service manual. Excessive high voltage can cause an increase in X-Ray emission, arcing and possible component damage, therefore operation under excessive high voltage conditions should be kept to a minimum, or should be prevented. If severe arcing occurs, remove the AC power immediately and determine the cause by visual inspection (incorrect installation, cracked or melted high voltage harness, poor soldering, etc.). To maintain the proper minimum level of soft X-Ray emission, components in the high voltage circuitry including the picture tube must be the exact replacements or alternatives approved by the manufacturer of the complete product.
- (8) Do not check high voltage by drawing an arc. Use a high voltage meter or a high voltage probe with a VTVM. Discharge the picture tube before attempting meter connection, by connecting a clip lead to the ground frame and connecting the other end of the lead through a 10k Ω 2W resistor to the anode button.
- (9) When service is required, observe the original lead dress. Extra precaution should be given to assure correct lead dress in the high voltage circuit area. Where a short circuit has occurred, those components that indicate evidence of overheating should be replaced. Always use the manufacturer's replacement components.

(10) Isolation Check (Safety for Electrical Shock Hazard)

After re-assembling the product, always perform an isolation check on the exposed metal parts of the cabinet (antenna terminals, video/audio input and output terminals, Control knobs, metal cabinet, screw heads, earphone jack, control shafts, etc.) to be sure the product is safe to operate without danger of electrical shock.

a) Dielectric Strength Test

The isolation between the AC primary circuit and all metal parts exposed to the user, particularly any exposed metal part having a return path to the chassis should withstand a voltage of 3000V AC (r.m.s.) for a period of one second. (. . . Withstand a voltage of 1100V AC (r.m.s.) to an appliance rated up to 120V, and 3000V AC (r.m.s.) to an appliance rated 200V or more, for a period of one second.)

This method of test requires a test equipment not generally found in the service trade.

b) Leakage Current Check

Plug the AC line cord directly into the AC outlet (do not use a line isolation transformer during this check.). Using a "Leakage Current Tester", measure the leakage current from each exposed metal part of the cabinet, particularly any exposed metal part having a return path to the chassis, to a known good earth ground (water pipe, etc.). Any leakage current must not exceed 0.5mA AC (r.m.s.).

However, in tropical area, this must not exceed 0.2mA AC (r.m.s.).

Alternate Check Method

Plug the AC line cord directly into the AC outlet (do not use a line isolation transformer during this check.). Use an AC voltmeter having 1000 Ω per volt or more sensitivity in the following manner. Connect a 1500 Ω 10W resistor paralleled by a 0.15 μ F AC-type capacitor between an exposed metal part and a known good earth ground (water pipe, etc.). Measure the AC voltage across the resistor with the AC voltmeter. Move the resistor connection to each exposed metal part, particularly any exposed metal part having a return path to the chassis, and measure the AC voltage across the resistor. Now, reverse the plug in the AC outlet and repeat each measurement. Any voltage measured must not exceed 0.75V AC (r.m.s.). This corresponds to 0.5mA AC (r.m.s.).

However, in tropical area, this must not exceed 0.3V AC (r.m.s.). This corresponds to 0.2mA AC (r.m.s.).

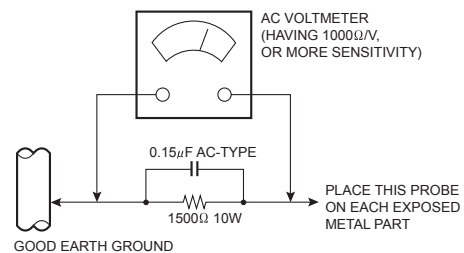

(11) High voltage hold down circuit check.

After repair of the high voltage hold down circuit, this circuit shall be checked to operate correctly. See item "How to check the high voltage hold down circuit".

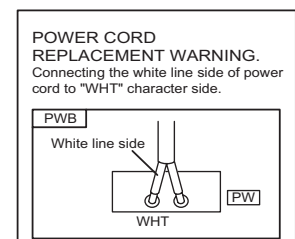
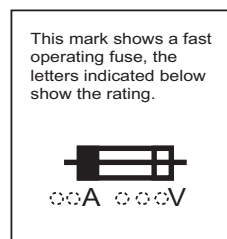

SECTION 2

SPECIFIC SERVICE INSTRUCTIONS

2.1 FEATURES

- Title TELE-TEXT broadcast of C1~C4 and T1~T4 formula is receivable.
- By the three-line digital comb filter, the refreshed image can be seen.
- Expression of a favorite screen can be chosen by the VIDEO STATUS function (STANDARD-DYNAMIC-THEATER / SPORTS-GAME).
- Sets automatically the proper conditions for playing video games (previously connected in the front input).
- Since the component signal input terminal is equipped, it reappears direct without deteriorating the signal from DVD.
- HYPER SOUND creates the deep, three-dimensional sound effect by channeling the audio through the TV' s front-fitting speakers.
- The voice multiplex function of the MTS system is built in. (MTS = Multi channel TV Sound system)
- Return+ program a specific channel to return to while scanning through the channels using the CH+ and CH- buttons.

2.2 MAIN DIFFERENCE LIST

- The difference between RA models and SA models is in the PICTURE TUBE. As the result of the difference in PICTURE TUBE, the MAIN PWB also differ.

2.2.1 DIFFERENCE IN FEATURES

Part name	AV-N29304 /RA	AV-N29304 /SA	AV-N29430 /RA	AV-N29430 /SA
TELE-TEXT	Available	Available	Available	Available
Digital comb filter	Available	Available	Available	Available
Video status (THEATER)	Available	Available	----	----
Video status (SPORTS)	----	----	Available	Available
GAME button	Available	Available	Available	Available
Component input terminal	Available	Available	Available	Available
Hyper-Surround	Available	Available	----	----
MTS Stereo	Available	Available	Available	Available
Return +	Available	Available	Available	Available

2.2.2 DIFFERENCE IN PARTS

△	Part name	AV-N29304 /RA	AV-N29304 /SA	AV-N29430 /RA	AV-N29430 /SA
△	MAIN PWB	SFE-1036A-M2	SFE-1035A-M2	SFE-1034A-M2	SFE-1033A-M2
△	PICTURE TUBE (ITC)	A68ADT25X881	A68QDN891X001	A68ADT25X881	A68QDN891X001
△	FRONT CABINET ASS'Y	GQ10018-003C-A	GQ10018-003C-A	LC10081-008B-A	LC10081-008B-A
△	REAR COVER	GQ10017-001B-A	GQ10017-001B-A	LC10082-003A-A	LC10082-003A-A
	REMOTE CONTROL UNIT	RM-C1255G-1H	RM-C1255G-1H	RM-C203-1C	RM-C203-1C

2.3 HOW TO IDENTIFY MODELS

How to recognize from the appearance of the model concerned is written on the rating label. Please distinguish from several contents on the printing label.

2.4 FUNCTIONS

[FRONT PANEL]
<AV-N29304>

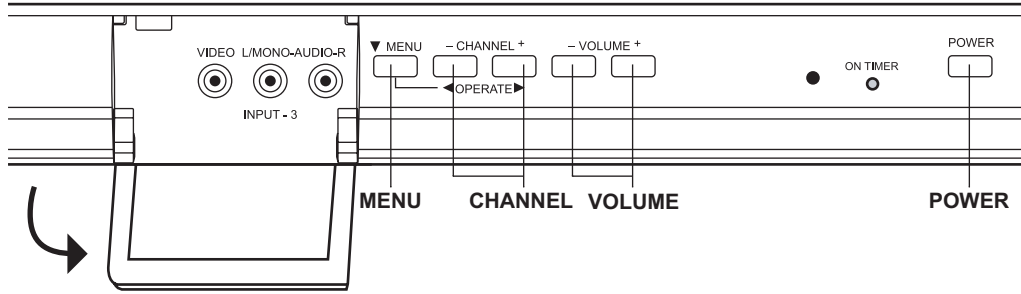

<AV-N29430>

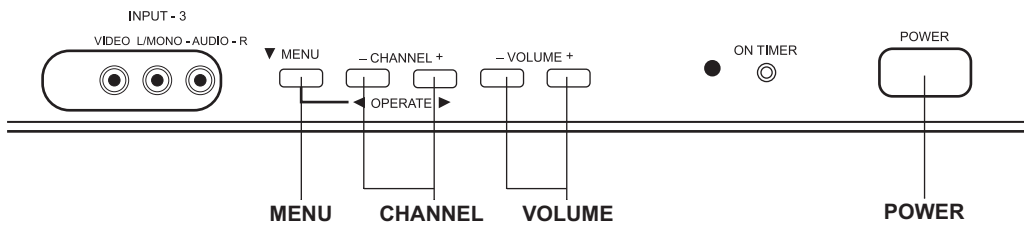

[REAR PANEL]
<AV-N29304>

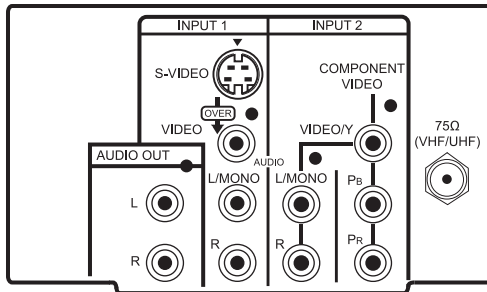

<AV-N29430>

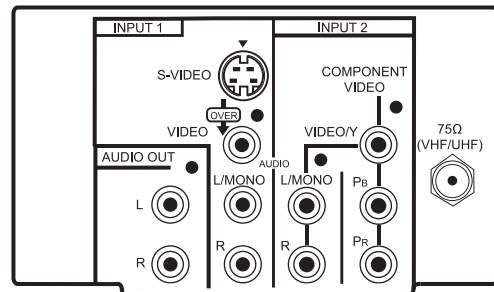

[REMOTE CONTROL UNIT]

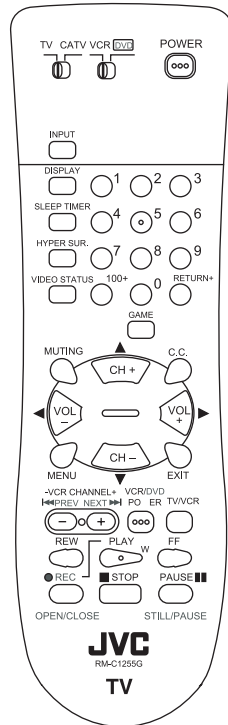

AV-N29304 (RM-C1255G)

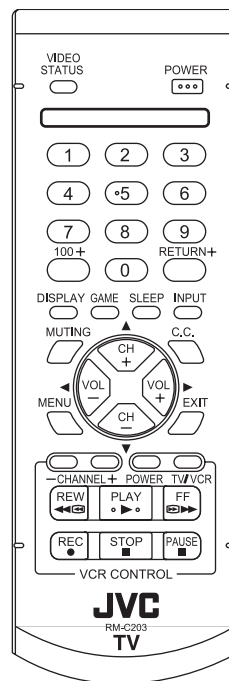

AV-N29430 (RM-C203)

2.5 DISASSEMBLY PROCEDURE

2.5.1 REMOVING THE REAR COVER [AV-N29304]

- (1) Unplug the power plug.
- (2) Remove the 11 screws **[A]** (Fig.1).
- (3) Remove the 4 screws **[B]** (Fig.1).
- (4) Then remove the REAR COVER toward you.

2.5.2 REMOVING THE REAR COVER [AV-N29430]

- (1) Unplug the power plug.
- (2) Remove the 7 screws **[A]** (Fig.2).
- (3) Remove the 4 screws **[B]** (Fig.2).
- (4) Then remove the REAR COVER toward you.

2.5.3 REMOVING THE MAIN PWB

- Remove the REAR COVER.
 - (1) Raise this side of the MAIN PWB, and remove the PWB STOPPER **[C]** from the cabinet.
 - (2) Withdraw the MAIN PWB backward. (If necessary, remove the wire clamp, connectors etc.)

2.5.4 REMOVING THE SPEAKER [AV-N29304]

- Remove the REAR COVER.
 - (1) Remove the 4 screws **[D]**, then remove the speaker (Fig.1).
 - (2) Follow the same steps when remove the other hand speaker.

2.5.5 REMOVING THE SPEAKER [AV-N29430]

- Remove the REAR COVER.
 - (1) Remove the 4 screws **[D]**, then remove the speaker (Fig.2).
 - (2) Follow the same steps when remove the other hand speaker.

NOTE:

When removing the 4 screws **[D]** of the speaker, remove the lower side screw first, and then remove the upper one.

2.5.6 CHECKING THE PW BOARD

- (1) Pull out the MAIN PWB (refer to REMOVING THE MAIN PWB).
- (2) Erect the MAIN PWB vertically so that you can easily check the backside of the PW Board.

CAUTION:

- When erecting the chassis, be careful so that there will be no contacting with other PW Board.
- Before turning on power, make sure that the wire connector is properly connected.
- When conducting a check with power supplied, be sure to confirm that the CRT EARTH WIRE (BRAIDED ASS'Y) is connected to the CRT SOCKET PW board.

2.5.7 WIRE CLAMPING AND CABLE TYING

- (1) Be sure to clamp the wire.
- (2) Never remove the cable tie used for tying the wires together.
Should it be inadvertently removed, be sure to tie the wires with a new cable tie.

[AV-N29304]

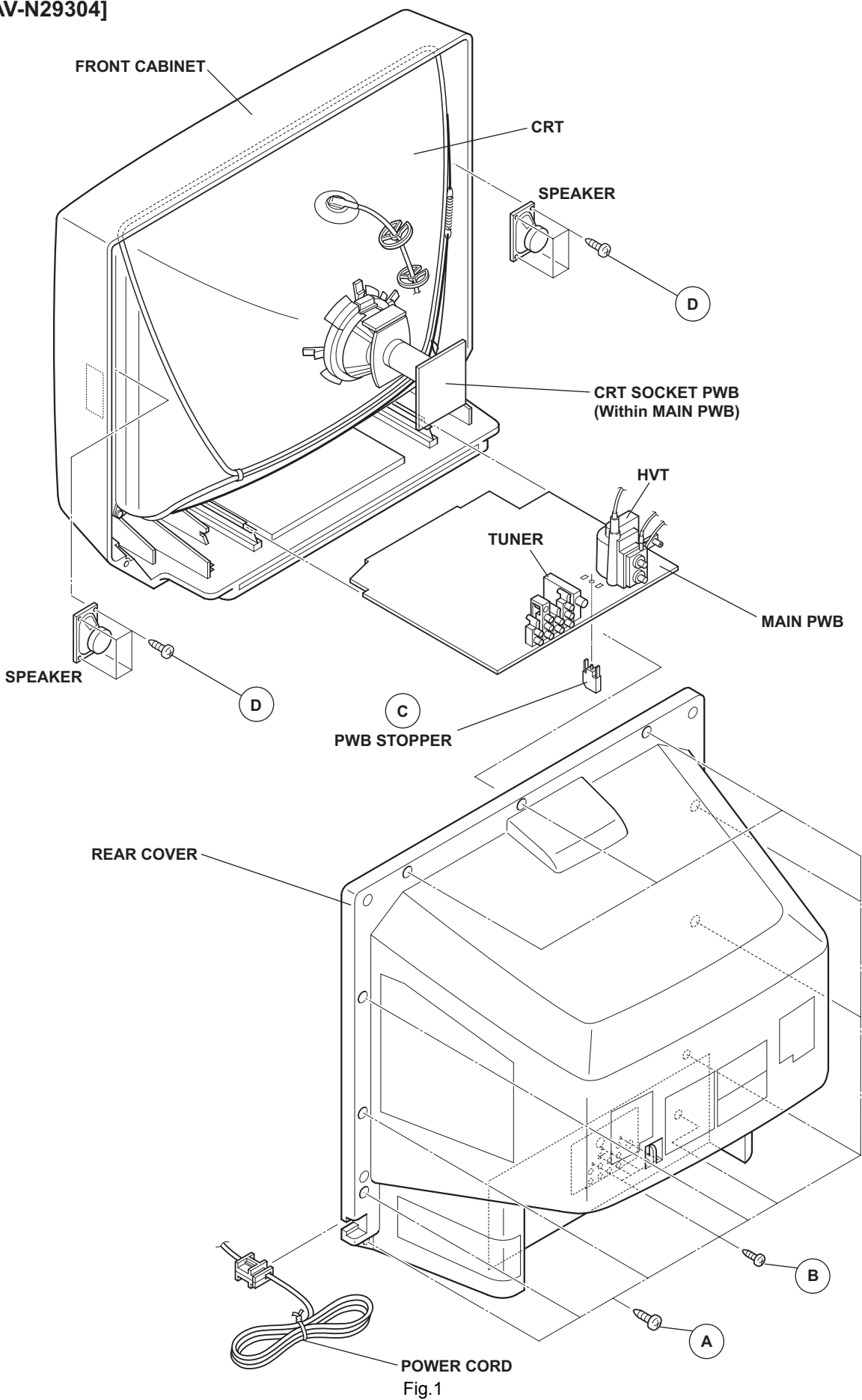

Fig.1

[AV-N29430]

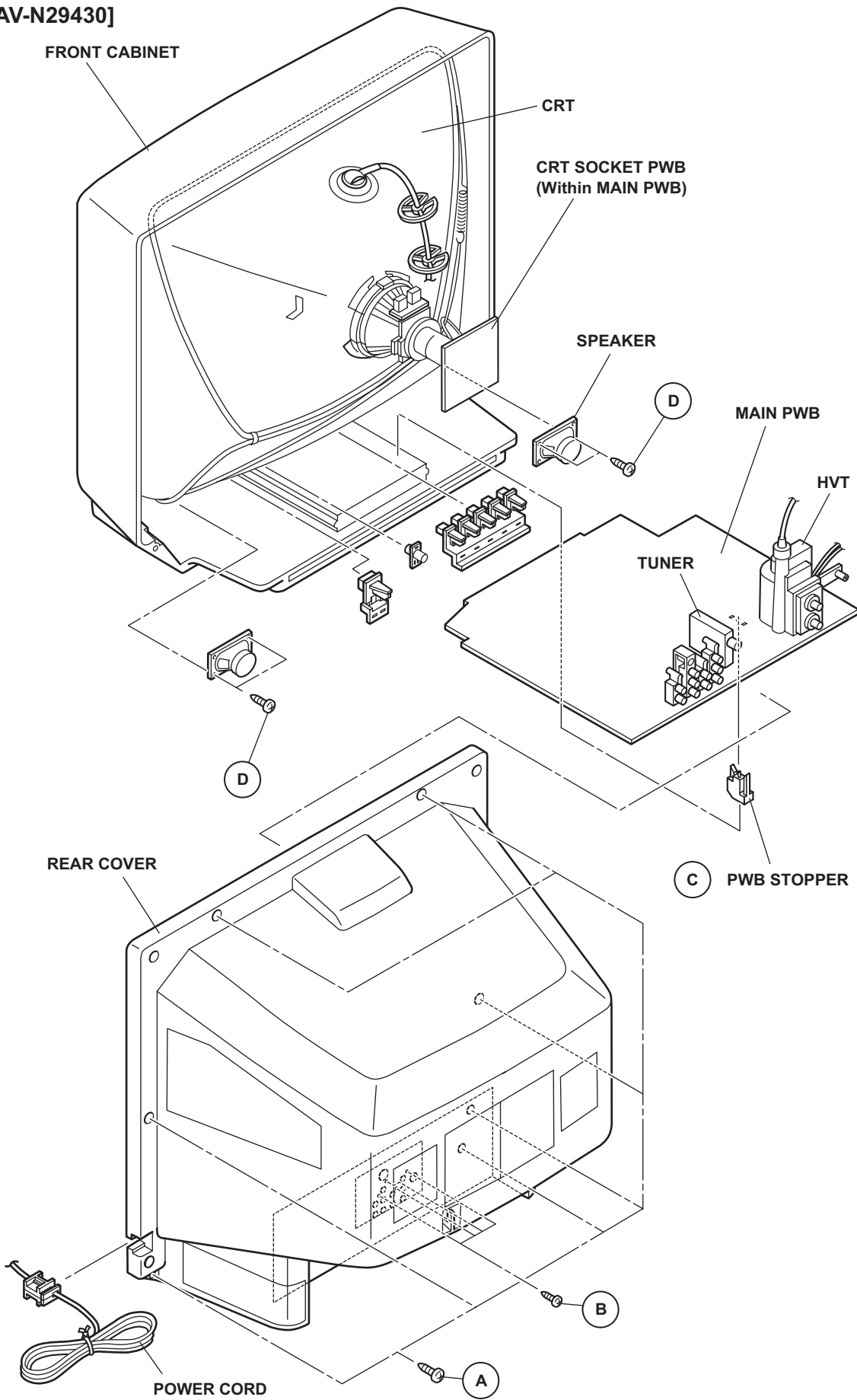

Fig.2

2.6 MEMORY IC REPLACEMENT

2.6.1 MEMORY IC

This TV use memory IC.

In the memory IC, there are memorized data for correctly operating the video and deflection circuits.

When replacing the memory IC, be sure to use IC written with the initial values of data.

2.6.2 PROCEDURE FOR REPLACING MEMORY IC

(1) Power off

Switch the power off and unplug the power cord from the outlet.

(2) Replace IC

Be sure to use a memory IC written with the initial setting data.

(3) Power on

Connect the power cord to the outlet and switch the power on.

(4) Setting of receive channels

Set the receive channels. For setting, refer to the OPERATING INSTRUCTIONS.

(5) User settings

Check the user setting items according to "USER SETTING VALUES", and if these are different, set the correct value.

(6) SERVICE MENU setting

Verify what to set in the SERVICE MENU, and set whatever is necessary. Refer to the SERVICE ADJUSTMENT for setting.

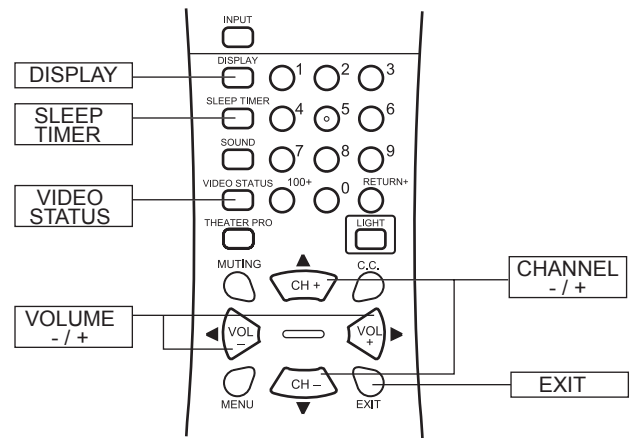
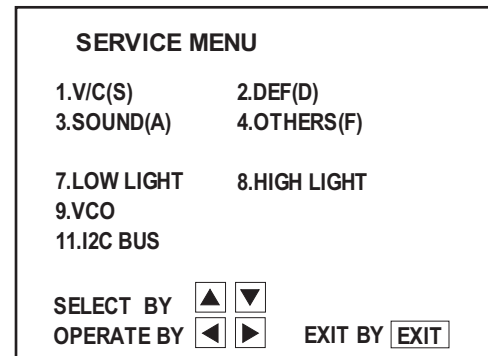

NOTE:

Although this illustration of remote control unit is written about RM-C1255G(AV-N29304), it can use for operating the other model of remote control unit as same key assignment.

2.6.3 USER SETTING VALUES

Setting item	Setting value	Setting item	Setting value
REMOTE CONTROL UNIT KEY			
POWER	OFF	VIDEO STATUS	DYNAMIC
CHANNEL	CH-02	HYPER SURROUND	OFF
VOLUME	15	GAME	OFF
TV/VIDEO	TV		
DISPLAY	OFF		
SETTING OF MENU			
PICTURE MODE		INITIAL SETUP MODE	
TINT	Center	LANGUAGE	SPA
COLOR	Center	FRONT PANEL LOCK	OFF
PICTURE	+8	V2 COMPONENT-IN	NO
BRIGHT	Center	AUTO SHUT OFF	OFF
DETAIL	+10	CLOSED CAPTION	OFF
NOISE MUTING	ON	AUTO TUNER SET UP	AIR
SOUND MODE		CHANNEL SUMMARY	Unnecessary to set
BASS	Center	SET LOCK CODE	(0000) Unnecessary to set
TREBLE	Center	XDS ID	ON
BALANCE	Center		
MTS	STEREO		
CLOCK / TIMERS MODE			
SET CLOCK	Manual		
TIME ZONE	PACIFIC		
D.S.T.	OFF		
ON / OFF TIMER	OFF		

2.7 REPLACEMENT OF CHIP COMPONENT

2.7.1 CAUTIONS

- (1) Avoid heating for more than 3 seconds.
- (2) Do not rub the electrodes and the resist parts of the pattern.
- (3) When removing a chip part, melt the solder adequately.
- (4) Do not reuse a chip part after removing it.

2.7.2 SOLDERING IRON

- (1) Use a high insulation soldering iron with a thin pointed end of it.
- (2) A 30w soldering iron is recommended for easily removing parts.

2.7.3 REPLACEMENT STEPS

1. How to remove Chip parts [Resistors, capacitors, etc.]

- (1) As shown in the figure, push the part with tweezers and alternately melt the solder at each end.

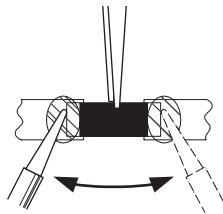

- (2) Shift with the tweezers and remove the chip part.

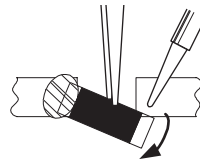

[Transistors, diodes, variable resistors, etc.]

- (1) Apply extra solder to each lead.



- (2) As shown in the figure, push the part with tweezers and alternately melt the solder at each lead. Shift and remove the chip part.

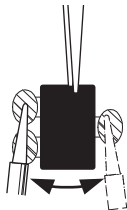

Note :

After removing the part, remove remaining solder from the pattern.

2. How to install Chip parts [Resistors, capacitors, etc.]

- (1) Apply solder to the pattern as indicated in the figure.

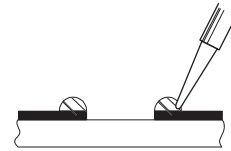

- (2) Grasp the chip part with tweezers and place it on the solder. Then heat and melt the solder at both ends of the chip part.

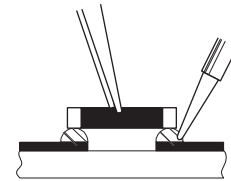

[Transistors, diodes, variable resistors, etc.]

- (1) Apply solder to the pattern as indicated in the figure.
- (2) Grasp the chip part with tweezers and place it on the solder.
- (3) First solder lead **A** as indicated in the figure.

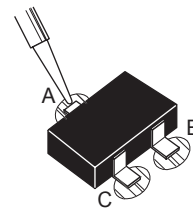

- (4) Then solder leads **B** and **C**.

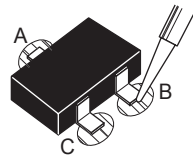

SECTION 3 ADJUSTMENT

3.1 ADJUSTMENT PREPARATION

- (1) There are 2 ways of adjusting this TV : One is with the REMOTE CONTROL UNIT and the other is the conventional method using adjustment parts and components.
- (2) The adjustment using the REMOTE CONTROL UNIT is made on the basis of the initial setting values. The setting values which adjust the screen to the optimum condition can be different from the initial setting values.
- (3) Make sure that connection is correctly made AC to AC power source.
- (4) Turn on the power of the TV and measuring instruments for warming up for at least 30 minutes before starting adjustments.
- (5) If the receive or input signal is not specified, use the most appropriate signal for adjustment.
- (6) Never touch the parts (such as variable resistors, transformers and condensers) not shown in the adjustment items of this service adjustment.
- (7) Preparation for adjustment. Unless otherwise specified in the adjustment items, preset the following functions with the REMOTE CONTROL UNIT.

Item	Preset value
PICTURE MODE (VSM)	DYNAMIC
BASS / TREBLE / BALANCE	Center
HYPER SURROUND	OFF
TINT / COLOR / PICTURE / BRIGHT / DETAIL	Center
MTS	STEREO

3.2 MEASURING INSTRUMENT AND FIXTURES

- (1) DC voltmeter (or digital voltmeter)
- (2) Oscilloscope
- (3) Signal generator (Pattern generator) [NTSC]
- (4) TV audio multiplex signal generator
- (5) Remote control unit

3.3 ADJUSTMENT LOCATIONS

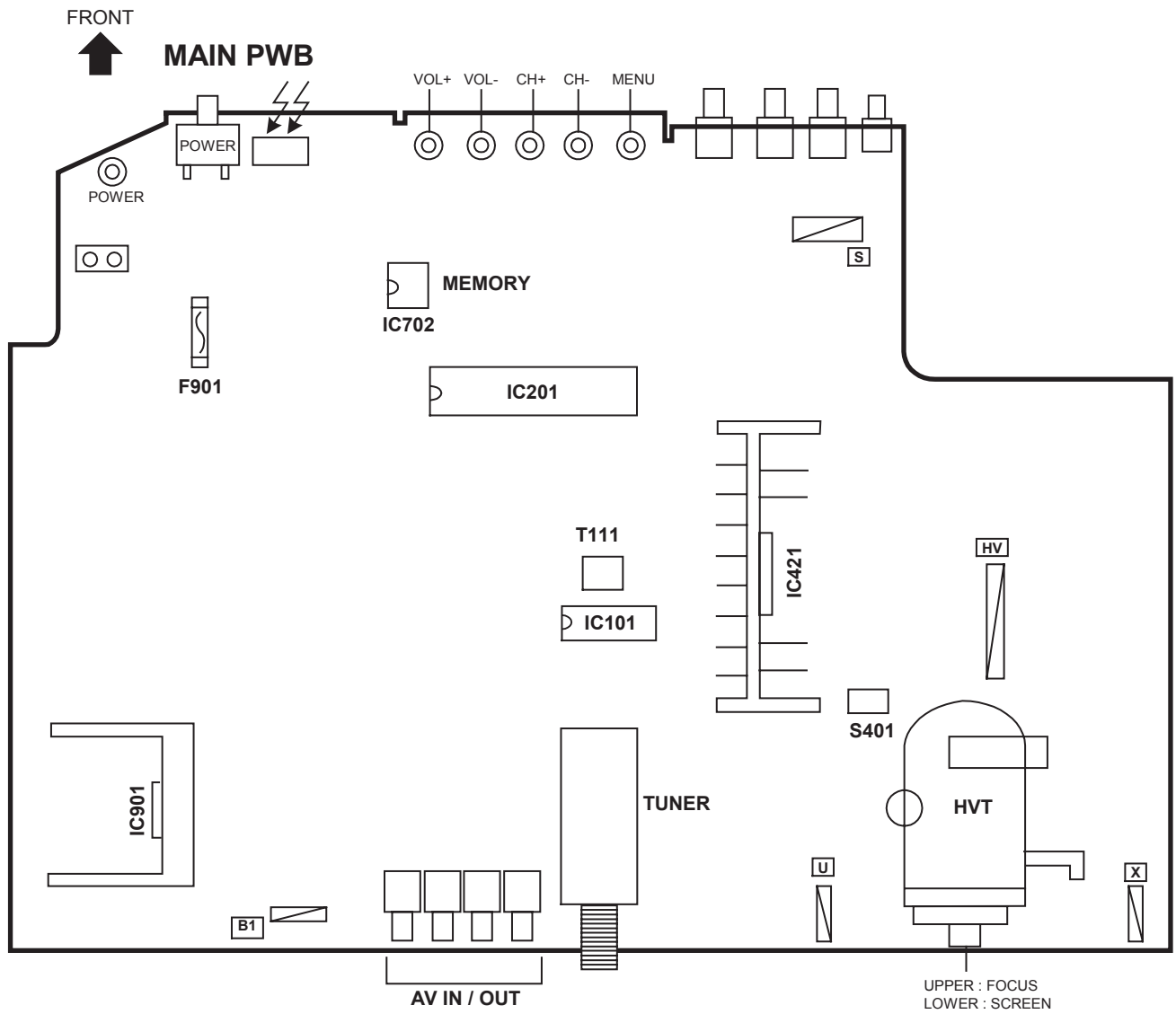
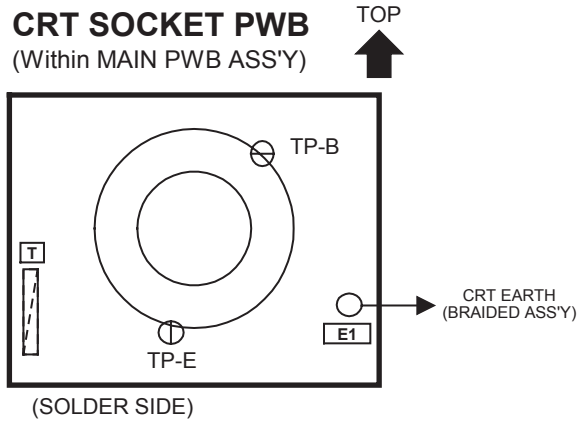

3.4 BASIC OPERATION OF SERVICE MENU

3.4.1 TOOL OF SERVICE MENU OPERATION

Operate the SERVICE MENU with the REMOTE CONTROL UNIT.

3.4.2 SERVICE MENU ITEMS

With the SERVICE MENU, various adjustments can be made, and they are broadly classified in the following items of settings.

1. V/C (S)	This mode adjusts the VIDEO and CHROMA control circuit.
2. DEF (D)	This mode adjusts the DEFLECTION control circuit.
3. SOUND (A)	This mode adjusts the SOUND control circuit.
4. OTHERS (F)	This mode adjusts the display setting and the other settings (Do not change the values).
7. LOW LIGHT	This mode adjusts the WHITE BALANCE (LOW LIGHT) control circuit.
8. HIGH LIGHT	This mode adjusts the WHITE BALANCE (HIGH LIGHT) control circuit.
9. VCO	This mode adjusts the VCO control circuit.
11. I2C BUS	This mode adjusts the I2C BUS control circuit (They are fixed).

3.4.3 BASIC OPERATION IN SERVICE MENU

3.4.3.1 HOW TO ENTER THE SERVICE MENU

(1) Press the [SLEEP TIMER] key and set the SLEEP TIMER for "0 MIN".

Then press the [DISPLAY] key and [VIDEO STATUS] key of the remote control unit at the same time to enter the SERVICE MENU screen.

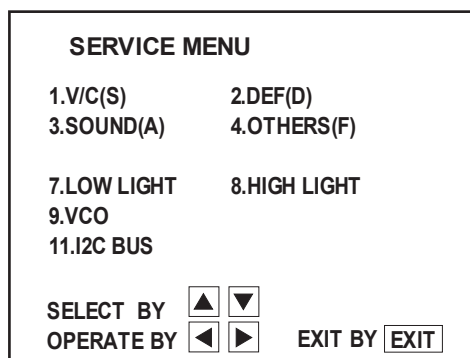

3.4.3.2 SUB MENU SCREEN SELECTION

Press [VOLUME (-/+)] keys of the REMOTE CONTROL UNIT, and select the SUB MENU SCREEN from SERVICE MENU.

In SERVICE MENU, press the [CHANNEL (-/+)] key to select any of the SUB MENU items. The letters of the selected items are displayed in yellow.

- | | |
|-------------------------|--------------|
| 1.V/C(S) | 2.DEF(D) |
| 3.SOUND(A) | 4.OTHERS(F) |
| 7.LOW LIGHT | 8.HIGH LIGHT |
| 9.VCO | |
| 11.I ² C BUS | |

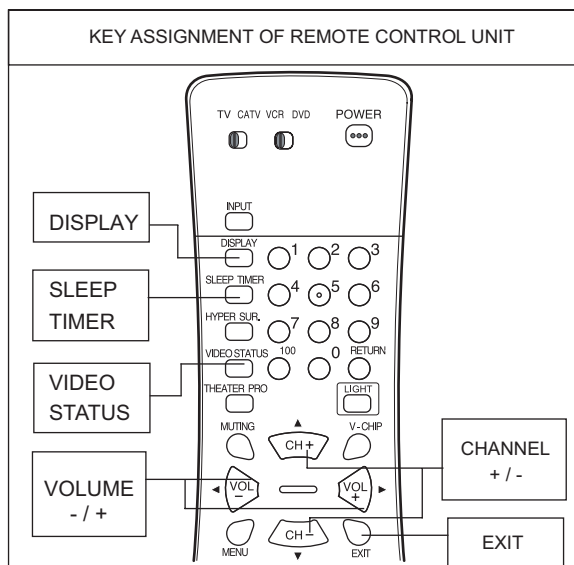

NOTE:

Although this illustration of remote control unit is written about RM-C1255G(AV-N29304), it can use for operating the other model of remote control unit as same key assignment.

3.4.3.3 SETTING METHOD

[1.V/C(S) ADJUSTMENT MODE]

For example, adjust the 1.V/C(S) by using the REMOTE CONTROL UNIT.

- 1) Press the [CHANNEL (-/+)] keys to select the one of setting item from S01 BRIGHT to S21 AGC ADJ.
- 2) Press the [VOLUME (-/+)] keys to change the setting value. The setting value will be stored automatically when release the REMOTE CONTROL UNIT keys. It can adjust the items from 1.V/C(S) to 3.SOUND(A) in the same procedure.

[7.LOW LIGHT, 8.HIGH LIGHT AND 9.VCO ADJUSTMENT MODE]

Since the key operation in this mode is peculiar, please refer to the clause of the "ADJUSTMENT PROCEDURE".

[4.OTHERS AND 11.I2C BUS ADJUSTMENT MODE]

These are no requirement for adjustment. Don't change these values.

3.4.3.4 Release of SERVICE MENU

When adjustment is completed, press the [EXIT] key twice. Then return to the normal screen.

3.4.4 SERVICE MENU FLOW CHART

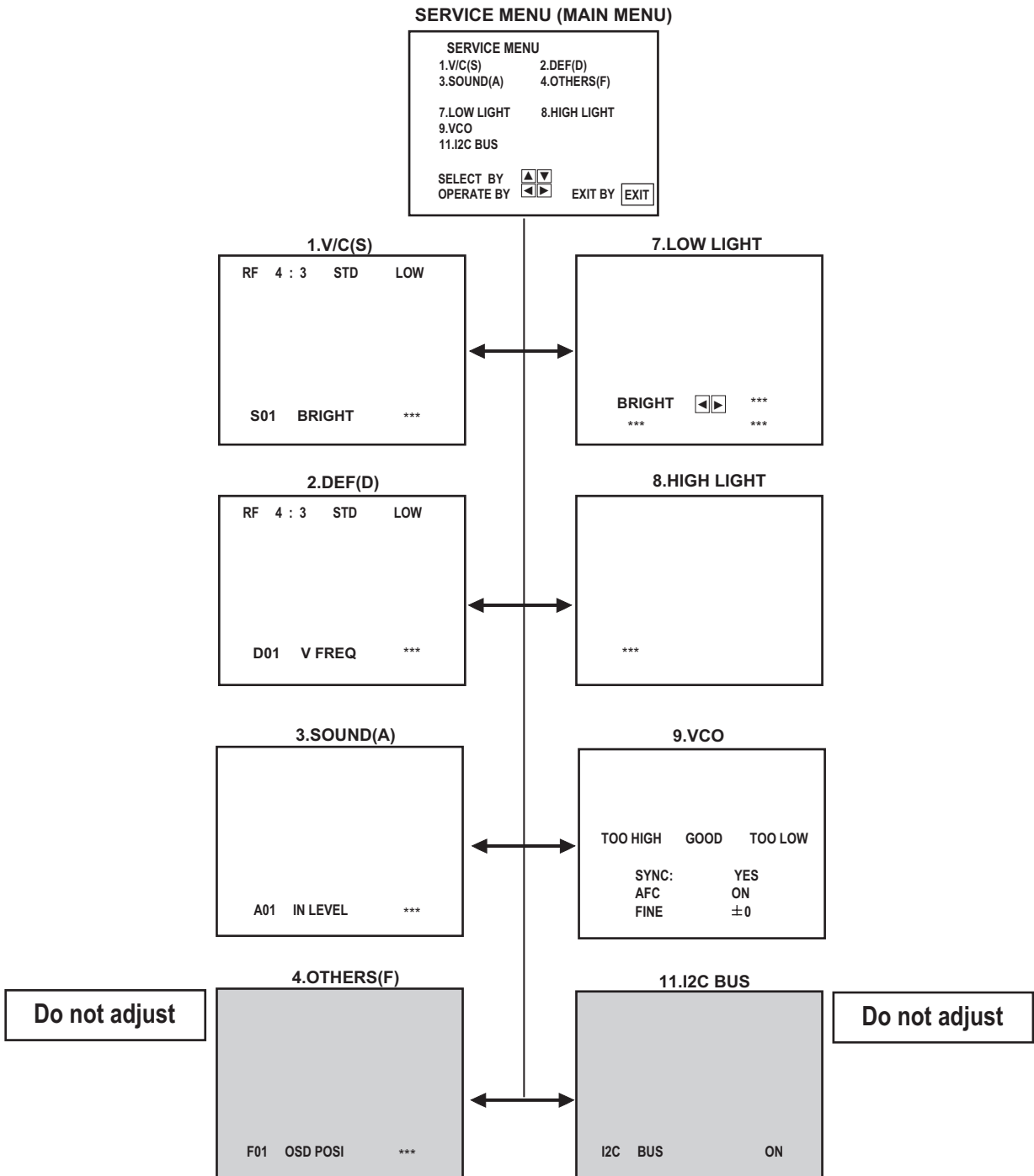

3.5 INITIAL SETTING VALUE OF SERVICE MENU

- (1) Adjustment of the service menu is made on the basis of the initial setting values. however, the new setting values which displays on the screen in its optimum condition may differ from the initial setting value.
- (2) Do not change the initial setting values of the items not listed in "ADJUSTMENT PROCEDURE".
- (3) "---" is impossible to adjust.

3.5.1 [1.V / C]

No.	Setting item	Variable range	Initial setting value					
			RF		EXTERNAL (SV,CV)		COMPONENT	
			STANDARD	THEATER	STANDARD	THEATER	STANDARD	THEATER
S01	BRIGHT	0~127	64	---	---	---	---	---
S02	PICTURE	0~127	65	---	---	---	---	---
S03	COLOR	0~127	45	---	---	---	55	---
S04	TINT	0~127	60	---	---	---	63	---
S05	DETAIL	0~63	35	---	40	---	40	---
S06	BRIGHT +-	-128~+127	---	0	1	---	+1	---
S07	PICT+-	-128~+127	---	-15	0	---	0	---
S08	COLOR +-	-128~+127	---	-3	1	---	---	---
S09	TINT+-	-128~+127	---	-6	-3	---	---	---
S10	DETAIL+-	-128~+127	---	+3	---	---	---	---

[AV-N29304]

No.	Setting item	Variable range	Initial setting value							
			RF/EXT (SV,CV)				COMPONENT			
			STANDARD		THEATER		STANDARD		THEATER	
			LOW	HIGH	LOW	HIGH	LOW	HIGH	LOW	HIGH
S11	R CUT OFF	0~255	30	---	---	---	---	---	---	---
S12	G CUT OFF	0~255	30	---	---	---	---	---	---	---
S13	B CUT OFF	0~255	30	---	---	---	---	---	---	---
S14	R DRIVE	0~127	64	---	---	---	---	---	---	---
S15	B DRIVE	0~127	64	---	---	---	---	---	---	---
S16	R CUT+-	-128~+127	---	0	0	0	0	---	---	---
S17	G CUT+-	-128~+127	---	0	0	0	0	---	---	---
S18	B CUT+-	-128~+127	---	0	0	0	0	---	---	---
S19	R DRV+-	-128~+127	---	+5	+13	+7	0	---	---	---
S20	B DRV+-	-128~+127	---	+6	-25	-9	0	---	---	---

[AV-N29430]

No.	Setting item	Variable range	Initial setting value							
			RF/EXT (SV,CV)				COMPONENT			
			STANDARD		THEATER		STANDARD		THEATER	
			LOW	HIGH	LOW	HIGH	LOW	HIGH	LOW	HIGH
S11	R CUT OFF	0~255	30	---	---	---	---	---	---	---
S12	G CUT OFF	0~255	30	---	---	---	---	---	---	---
S13	B CUT OFF	0~255	30	---	---	---	---	---	---	---
S14	R DRIVE	0~127	64	---	---	---	---	---	---	---
S15	B DRIVE	0~127	64	---	---	---	---	---	---	---
S16	R CUT+-	-128~+127	---	0	0	0	0	---	---	---
S17	G CUT+-	-128~+127	---	0	0	0	0	---	---	---
S18	B CUT+-	-128~+127	---	0	0	0	0	---	---	---
S19	R DRV+-	-128~+127	---	0	+7	+7	0	---	---	---
S20	B DRV+-	-128~+127	---	0	-9	-9	0	---	---	---

No.	Setting item	Variable range	Initial setting value
S21	AGC ADJUST	0~127	80

3.5.2 [2.DEF]

No.	Setting item	Variable range	Initial setting value	
			RF	EXTERNAL (SV, CV)
D01	AFC GAIN	0~3	0	2
D02	H POSI	0~31	10 (/RA model) / 9 (/SA model)	10(/RA model) / 9 (/SA model)
D03	V SIZE	0~125	65	65
D04	V S CORR	0~15	3 (/RA model) / 4 (/SA model)	3 (/RA model) / 4 (/SA model)
D05	V LIN	0~15	8	8
D06	H SIZE	0~63	32	32
D07	WVMT TOP	0~3	0 (/RA model) / 1 (/SA model)	0 (/RA model) / 1 (/SA model)
D08	WVMT BTM	0~3	0	0
D09	EWCR TOP	0~31	16	16
D10	EWCR BTM	0~31	16	16
D11	EW PARA	0~63	26	26
D12	BLANK SW	0~1	0	0

3.5.3 [3.SOUND]

No.	Setting item	Variable range	Initial setting value
A01	IN LEVEL	0~63	17
A02	FH MON	0~1	0
A03	ST VCO	0~63	36
A04	PIL CAN	0~1	0
A05	FILTER	0~63	35
A06	LOW SEP	0~63	7
A07	HI SEP	0~63	18
A08	5FH MON	0~1	0
A09	SAP VCO	0~63	37

3.5.4 [4.OTHERS]

No.	Setting item	Variable range	Initial setting value
F01	OSD POSI	0~255	22
F02	OSD PREQ	0~255	83
F03	CCD POSI	0~63	42
F04	CCD FREQ	0~255	93
F05	CCD CONT	0~63	11
F06	PUR CONT	0~255	62
F07	VNR CHK	0~255	3
F08	VCSN TM	0~255	5
F09	CCD PCHK	0~1	1

3.5.5 [7.LOW LIGHT]

No.	Setting item	Variable range	Initial setting value
1	RED	0~255	30
2	GREEN	0~255	30
3	BLUE	0~255	30

3.5.6 [8.HIGH LIGHT]

No.	Setting item	Variable range	Initial setting value
1	RED	0~255	64
2	BLUE	0~255	64

3.6 ADJUSTMENT PROCEDURE

3.6.1 CHECK ITEM

Item	Measuring instrument	Test point	Adjustment part	Description
B1 POWER SUPPLY	DC voltmeter Signal generator	B1 Connector 1-pin : TP-91 3-pin : TP-E [MAIN PWB]		(1) Receive the black-and-white signal. (color off) (2) Connect the DC voltmeter to TP-91 (B1 connector 1 pin) and TP-E (B1 connector 3 pin). (3) Confirm that the voltage is DC134V±2V.

3.6.2 VCO

Item	Measuring instrument	Test point	Adjustment part	Description											
IF VCO	Remote control unit		[9.VCO] CW transf. (T111) [MAIN PWB]	<ul style="list-style-type: none"> It must not adjust without inputting the RF signal. <ol style="list-style-type: none"> Receive a broadcast. Select 9.VCO mode from the SERVICE MENU. Change the [AFC] to OFF and [FINE] to 0. Confirm that the color change from "TOO HIGH" to "TOO LOW" by CW transf. on MAIN PWB, and check the [SYNC] is YES. Adjust CW transf. until "GOOD" letters turns green. And then confirm that the [SYNC] is YES again. Adjustment can be done in this statement. It return the [AFC] to ON. Push the [EXIT] key to exit the [9.VCO] mode. 											
<table border="1" style="margin: auto;"> <tr> <td>TOO HIGH</td> <td>GOOD</td> <td>TOO LOW</td> </tr> <tr> <td>SYNC:</td> <td>YES</td> <td></td> </tr> <tr> <td>AFC</td> <td>ON</td> <td></td> </tr> <tr> <td>FINE</td> <td>±0</td> <td></td> </tr> </table>					TOO HIGH	GOOD	TOO LOW	SYNC:	YES		AFC	ON		FINE	±0
TOO HIGH	GOOD	TOO LOW													
SYNC:	YES														
AFC	ON														
FINE	±0														

3.6.3 RF AGC

Item	Measuring instrument	Test point	Adjustment part	Description							
RF AGC	Signal generator Remote control unit		[1.V/C(S)] S21 : AGC ADJ	<ol style="list-style-type: none"> Receive a black-and-white signal (colour off). Select <S21>(AGC ADJ) of the 1.V/C(S). Press the [MUTING] key and turn the picture color off. With the [VOLUME (-)] key to get the noise in the screen picture (zero side of setting value). Press the [VOLUME (+)] key several times and step when noise disappears from the screen (at that time, not to increase the value too much). Change to other channels and make sure that there is no irregularity. Press the [MUTING] key and get color out. 							
<table border="1" style="margin: auto;"> <thead> <tr> <th>No.</th> <th>Setting item</th> <th>Variable range</th> <th>Initial setting value</th> </tr> </thead> <tbody> <tr> <td>S21</td> <td>AGC ADJ</td> <td>0~127</td> <td>80</td> </tr> </tbody> </table>					No.	Setting item	Variable range	Initial setting value	S21	AGC ADJ	0~127
No.	Setting item	Variable range	Initial setting value								
S21	AGC ADJ	0~127	80								

3.6.4 ADJUSTMENT OF FOCUS

Item	Measuring instrument	Test point	Adjustment part	Description
FOCUS	Signal generator		FOCUS VR [In HVT]	<ol style="list-style-type: none"> Receive the crosshatch signal. While looking at the screen, adjust the FOCUS VR to the vertical and horizontal lines will be clear and in fine detail. Make sure that the picture is in focus even when the screen gets darkened.

3.6.5 DEFLECTION CIRCUIT

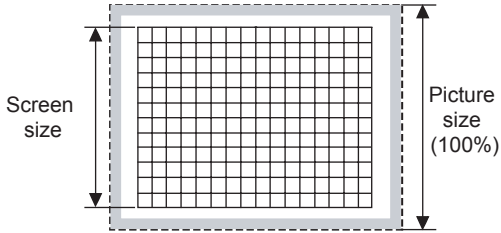
Item	Measuring instrument	Test point	Adjustment part	Description															
V. SIZE & V. CENTER	Signal generator		[2.DEF(D)] D03 : V SIZE	(1) Receive the crosshatch signal. (2) Select the <D03>(V SIZE). (3) Adjust the <D03> so that the vertical screen size becomes the value given below. (4) Adjust the V. CENTER SW to agree the vertical center with display center.															
	Remote control unit		V. CENTER SW(S401) [MAIN PWB]																
																			
<table border="1" style="width: 100%; border-collapse: collapse;"> <thead> <tr> <th style="width: 30%;">Model name</th> <th style="width: 70%;">Vertical screen size</th> </tr> </thead> <tbody> <tr> <td>RA model</td> <td>90.0%</td> </tr> <tr> <td>SA model</td> <td>89.0%</td> </tr> </tbody> </table>					Model name	Vertical screen size	RA model	90.0%	SA model	89.0%									
Model name	Vertical screen size																		
RA model	90.0%																		
SA model	89.0%																		
<table border="1" style="width: 100%; border-collapse: collapse;"> <thead> <tr> <th style="width: 10%;">No.</th> <th style="width: 20%;">Setting item</th> <th style="width: 20%;">Variable range</th> <th style="width: 50%;">Initial setting value</th> </tr> </thead> <tbody> <tr> <td>D03</td> <td>V SIZE</td> <td>0~125</td> <td>40</td> </tr> </tbody> </table>					No.	Setting item	Variable range	Initial setting value	D03	V SIZE	0~125	40							
No.	Setting item	Variable range	Initial setting value																
D03	V SIZE	0~125	40																
H. CENTER	Signal generator		[2.DEF(D)] D02 : H POSI	(1) Receive the crosshatch signal. (2) Select <D02>(H POSI). (3) Adjust the <D02> so that left width and right width of the crosshatch screen becomes equal.															
	Remote control unit																		
<table border="1" style="width: 100%; border-collapse: collapse;"> <thead> <tr> <th style="width: 20%;">Model name</th> <th style="width: 10%;">No.</th> <th style="width: 15%;">Setting item</th> <th style="width: 15%;">Variable range</th> <th style="width: 40%;">Initial setting value</th> </tr> </thead> <tbody> <tr> <td>RA model</td> <td>D02</td> <td>H POSI</td> <td>0~31</td> <td>10</td> </tr> <tr> <td>SA model</td> <td>D02</td> <td>H POSI</td> <td>0~31</td> <td>9</td> </tr> </tbody> </table>					Model name	No.	Setting item	Variable range	Initial setting value	RA model	D02	H POSI	0~31	10	SA model	D02	H POSI	0~31	9
Model name	No.	Setting item	Variable range	Initial setting value															
RA model	D02	H POSI	0~31	10															
SA model	D02	H POSI	0~31	9															

3.6.6 VIDEO CIRCUIT

Item	Measuring instrument	Test point	Adjustment part	Description																				
WHITE BALANCE (LOW LIGHT)	Signal generator Remote control unit		[7.LOW LIGHT] [1.V/C(S)] S11 : R CUTOFF S12 : G CUTOFF S13 : B CUTOFF S01 : BRIGHT SCREEN VR [in HVT]	<ol style="list-style-type: none"> (1) Receive the black-and-white signal (color off). (2) Select the 7.LOW LIGHT in the SERVICE MENU. (3) Set the initial setting value of <S11>(R CUTOFF), <S12>(G CUTOFF), <S13>(B CUTOFF) and <S01>(BRIGHT). (4) Display a single horizontal line by pressing the [1] key. (5) Turn the SCREEN VR all the way to the left. (6) Turn the SCREEN VR gradually to the right from the left until either one of the red, blue or green color appears faintly. (7) Adjust the two colors which did not appear until the single horizontal line that is displayed becomes white using the [4] to [9] keys. (8) Turn the SCREEN VR until the single horizontal line is displayed faintly. (9) Press the [2] key to cancel the single horizontal line mode. (10) Adjust the <S01> level to become the black component shines white slightly by [VOLUME] key. (11) Confirm that whether the color ingredient of R,G, or B is visible to the black component, which shines white slightly. (12) When the color ingredient can be seen, two colors other than a visible color is adjusted, and it is made to look white. (13) Return the value of <S01> to initial setting value. <p style="margin-left: 40px;">If the [3] key is pressed, it can escape from WHITE BALANCE adjustment mode.</p>																				
<div data-bbox="215 541 712 1016" style="border: 1px solid black; padding: 10px; margin-bottom: 10px;"> <p style="text-align: center;">KEY ASSIGNMENT OF REMOTE CONTROL UNIT</p> </div> <table border="1" data-bbox="172 1052 756 1289" style="margin-left: auto; margin-right: auto;"> <thead> <tr> <th>No.</th> <th>Setting item</th> <th>Variable range</th> <th>Initial setting value</th> </tr> </thead> <tbody> <tr> <td>S11</td> <td>R CUT OFF</td> <td>0~255</td> <td>30</td> </tr> <tr> <td>S12</td> <td>G CUT OFF</td> <td>0~255</td> <td>30</td> </tr> <tr> <td>S13</td> <td>B CUT OFF</td> <td>0~255</td> <td>30</td> </tr> <tr> <td>S01</td> <td>BRIGHT</td> <td>0~127</td> <td>64</td> </tr> </tbody> </table>					No.	Setting item	Variable range	Initial setting value	S11	R CUT OFF	0~255	30	S12	G CUT OFF	0~255	30	S13	B CUT OFF	0~255	30	S01	BRIGHT	0~127	64
No.	Setting item	Variable range	Initial setting value																					
S11	R CUT OFF	0~255	30																					
S12	G CUT OFF	0~255	30																					
S13	B CUT OFF	0~255	30																					
S01	BRIGHT	0~127	64																					

Item	Measuring instrument	Test point	Adjustment part	Description												
WHITE BALANCE (HIGH LIGHT)	Signal generator		[8.HIGH LIGHT] S14 : R DRIVE S15 : B DRIVE	(1) Receive the black-and-white signal (color off). (2) Select the 8.HIGH LIGHT in the SERVICE MENU. (3) Set the initial setting value of <S14>(R DRIVE) and <S15>(B DRIVE) with the [4], [6], [7] and [9] keys of the remote control unit. (4) Adjust the screen until it becomes white using the [4], [6], [7] and [9] keys of the remote control unit. The [3] EXIT key is the cancel key for the 8.HIGH LIGHT mode.												
	Remote control unit															
<div style="border: 1px solid black; padding: 10px; margin: 10px auto; width: fit-content;"> <p>KEY ASSIGNMENT OF REMOTE CONTROL UNIT</p> </div> <table border="1" style="margin: 10px auto; width: 60%; border-collapse: collapse;"> <thead> <tr> <th>No.</th> <th>Setting item</th> <th>Variable range</th> <th>Initial setting value</th> </tr> </thead> <tbody> <tr> <td>S14</td> <td>R DRIVE</td> <td>0~127</td> <td>64</td> </tr> <tr> <td>S15</td> <td>G DRIVE</td> <td>0~127</td> <td>64</td> </tr> </tbody> </table>					No.	Setting item	Variable range	Initial setting value	S14	R DRIVE	0~127	64	S15	G DRIVE	0~127	64
No.	Setting item	Variable range	Initial setting value													
S14	R DRIVE	0~127	64													
S15	G DRIVE	0~127	64													
SUB BRIGHT	Remote control unit		[1.V/C(S)] S01 : BRIGHT	(1) Receive the broadcast. (2) Select <S01>(BRIGHT) of the 1.V/C(S). (3) Set the initial setting value of the <S01> with the [VOLUME (-/+)] key. (4) If the brightness is not the best with the initial setting value, make fine adjustment of the <S01> until you get the optimum brightness.												
<table border="1" style="margin: 10px auto; width: 60%; border-collapse: collapse;"> <thead> <tr> <th>No.</th> <th>Setting item</th> <th>Variable range</th> <th>Initial setting value</th> </tr> </thead> <tbody> <tr> <td>S01</td> <td>BRIGHT</td> <td>0~127</td> <td>64</td> </tr> </tbody> </table>					No.	Setting item	Variable range	Initial setting value	S01	BRIGHT	0~127	64				
No.	Setting item	Variable range	Initial setting value													
S01	BRIGHT	0~127	64													
SUB CONTRAST	Remote control unit		[1.V/C(S)] S02 : PICTURE	(1) Receive the broadcast. (2) Select <S02>(PICTURE) of the 1.V/C(S). (3) Set the initial setting value of the <S02> with the [VOLUME (-/+)] key. (4) If the contrast is not the best with the initial setting value, make fine adjustment of the <S02> until you get the optimum contrast.												
<table border="1" style="margin: 10px auto; width: 60%; border-collapse: collapse;"> <thead> <tr> <th>No.</th> <th>Setting item</th> <th>Variable range</th> <th>Initial setting value</th> </tr> </thead> <tbody> <tr> <td>S02</td> <td>PICTURE</td> <td>0~127</td> <td>65</td> </tr> </tbody> </table>					No.	Setting item	Variable range	Initial setting value	S02	PICTURE	0~127	65				
No.	Setting item	Variable range	Initial setting value													
S02	PICTURE	0~127	65													

Item	Measuring instrument	Test point	Adjustment part	Description
SUB COLOR	Signal generator	TP-B TP-E [CRT SOCKET PWB]	[1.V/C(S)] S03 : COLOR	<p>[Method of adjustment without measuring instrument]</p> <p>(1) Receive the broadcast. (2) Select <S03>(COLOR) of the 1.V/C(S). (3) Set the initial setting value of the <S03> with the [VOLUME (-/+)] key. (4) If the color is not the best with the Initial setting value, make fine adjustment of the <S03> until you get the optimum color.</p> <p>[Method of adjustment using measuring instrument]</p> <p>(1) Receive the full field color bar signal (75% white). (2) Select <S03>(COLOR) of the 1.V/C(S). (3) Set the initial setting value of the <S03> with the [VOLUME (-/+)] key. (4) Connect the oscilloscope between TP-B and TP-E. (5) Adjust <S03> and bring the value of (A) in the illustration to the voltage given in the below table.</p>
	Oscilloscope			
	Remote control unit			

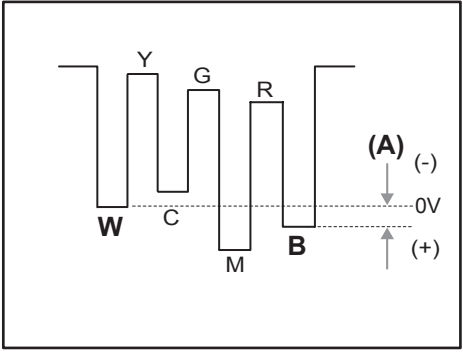

No.	Setting item	Variable range	Initial setting value
S03	COLOR	0~127	64

W-B Models	Adjustment Voltage
RA model	+17V
SA model	+15V

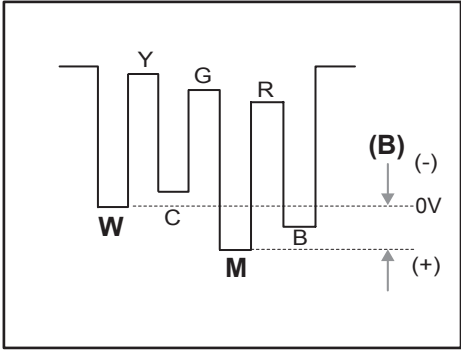
Item	Measuring instrument	Test point	Adjustment part	Description														
SUB TINT	Signal generator Oscilloscope Remote control unit	TP-B TP-E [CRT SOCKET PWB]	[1.V/C(S)] S04 : TINT	<p>[Method of adjustment without measuring instrument]</p> <p>(1) Receive the broadcast. (2) Select <S04>(TINT) of the 1.V/C. (3) Set the initial setting value of the <S04> with the [VOLUME (-/+)] key. (4) If the tint is not the best with the initial setting value, make fine adjustment of the <S04> until you get the optimum tint.</p>														
<div style="text-align: center;">  </div> <table border="1" data-bbox="246 863 829 1003" style="margin: 10px auto;"> <thead> <tr> <th>No.</th> <th>Setting item</th> <th>Variable range</th> <th>Initial setting value</th> </tr> </thead> <tbody> <tr> <td>S04</td> <td>TINT</td> <td>0~127</td> <td>64</td> </tr> </tbody> </table> <table border="1" data-bbox="287 1041 792 1199" style="margin: 10px auto;"> <thead> <tr> <th>Models \ W-B</th> <th>Adjustment Voltage</th> </tr> </thead> <tbody> <tr> <td>RA model</td> <td>+20V</td> </tr> <tr> <td>SA model</td> <td>+25V</td> </tr> </tbody> </table>				No.	Setting item	Variable range	Initial setting value	S04	TINT	0~127	64	Models \ W-B	Adjustment Voltage	RA model	+20V	SA model	+25V	<p>[Method of adjustment using measuring instrument]</p> <p>(1) Receive the full field color bar signal (75% white). (2) Select <S04>(TINT) of the 1.V/C. (3) Set the initial setting value of the <S04> with the [VOLUME (-/+)] key. (4) Connect the oscilloscope between TP-B and TP-E. (5) Adjust <S04> and bring the value of (B) in the illustration to the voltage given in the below table.</p>
No.	Setting item	Variable range	Initial setting value															
S04	TINT	0~127	64															
Models \ W-B	Adjustment Voltage																	
RA model	+20V																	
SA model	+25V																	

3.6.7 MTS CIRCUIT

Item	Measuring instrument	Test point	Adjustment part	Description												
MTS INPUT LEVEL	Remote control unit		[3.SOUND(A)] A01 : IN LEVEL	(1) Select the <A01>(IN LEVEL) of the 3.SOUND. (2) Verify that the <A01> is set at its initial setting value.												
	<table border="1"> <thead> <tr> <th>No.</th> <th>Setting item</th> <th>Variable range</th> <th>Initial setting value</th> </tr> </thead> <tbody> <tr> <td>A01</td> <td>IN LEVEL</td> <td>0~63</td> <td>017</td> </tr> </tbody> </table>				No.	Setting item	Variable range	Initial setting value	A01	IN LEVEL	0~63	017				
No.	Setting item	Variable range	Initial setting value													
A01	IN LEVEL	0~63	017													
MTS SEPARATION	TV audio multiplex signal generator	R OUT L OUT [AUDIO OUT]	[3.SOUND(A)] A06 : LOW SEP A07 : HI SEP	(1) Input the stereo L signal (300Hz) from the TV audio multiplex signal generator to the antenna terminal. (2) Connect an oscilloscope to R OUT pin of the AUDIO OUT, and display one cycle portion of the 300Hz signal. (3) Select the <A06>(LOW SEP) of the SOUND MODE. (4) Set the initial setting value of the <A06> with the [VOLUME (-/+)] key. (5) Adjust the <A06> so that the stroke element of the 300Hz signal will become minimum. (6) Change the connection of the oscilloscope to L OUT pin of the AUDIO OUT, and enlarge the voltage axis. (7) Change the signal to 3kHz, and similarly adjust the <A07>(HI SEP).												
	Oscilloscope Remote control unit	<div style="border: 1px solid black; padding: 10px; margin-bottom: 10px;"> <p>The diagram illustrates the adjustment process for MTS separation. On the left, the 'L-Channel signal waveform' shows a single cycle of a sine wave. On the right, the 'R-Channel crosstalk portion' shows a smaller amplitude sine wave. A horizontal line is drawn across the R-channel waveform, and a downward-pointing arrow labeled 'Minimum' indicates the goal is to reduce the peak-to-peak amplitude of the crosstalk to this level.</p> </div> <table border="1"> <thead> <tr> <th>No.</th> <th>Setting item</th> <th>Variable range</th> <th>Initial setting value</th> </tr> </thead> <tbody> <tr> <td>A06</td> <td>LOW SEP</td> <td>0~63</td> <td>007</td> </tr> <tr> <td>A07</td> <td>HI SEP</td> <td>0~63</td> <td>018</td> </tr> </tbody> </table>				No.	Setting item	Variable range	Initial setting value	A06	LOW SEP	0~63	007	A07	HI SEP	0~63
No.	Setting item	Variable range	Initial setting value													
A06	LOW SEP	0~63	007													
A07	HI SEP	0~63	018													

3.6.8 HOW TO CHECK THE HIGH VOLTAGE HOLD DOWN CIRCUIT

3.6.8.1 HIGH VOLTAGE HOLD DOWN CIRCUIT

After repairing the high voltage hold down circuit.

This circuit shall be checked to operate correctly.

3.6.8.2 CHECKING OF THE HIGH VOLTAGE HOLD DOWN CIRCUIT

- (1) Turn the power switch to on.
- (2) Refer to the following figure, set the resistor between X connector 1 and 3 .
- (3) Make sure that the screen picture disappears.
- (4) Temporarily unplug the power plug.
- (5) Remove the resistor replaced X connector 1 and 3 .
- (6) Again plug the power plug, make sure that the normal picture is displayed on the screen.

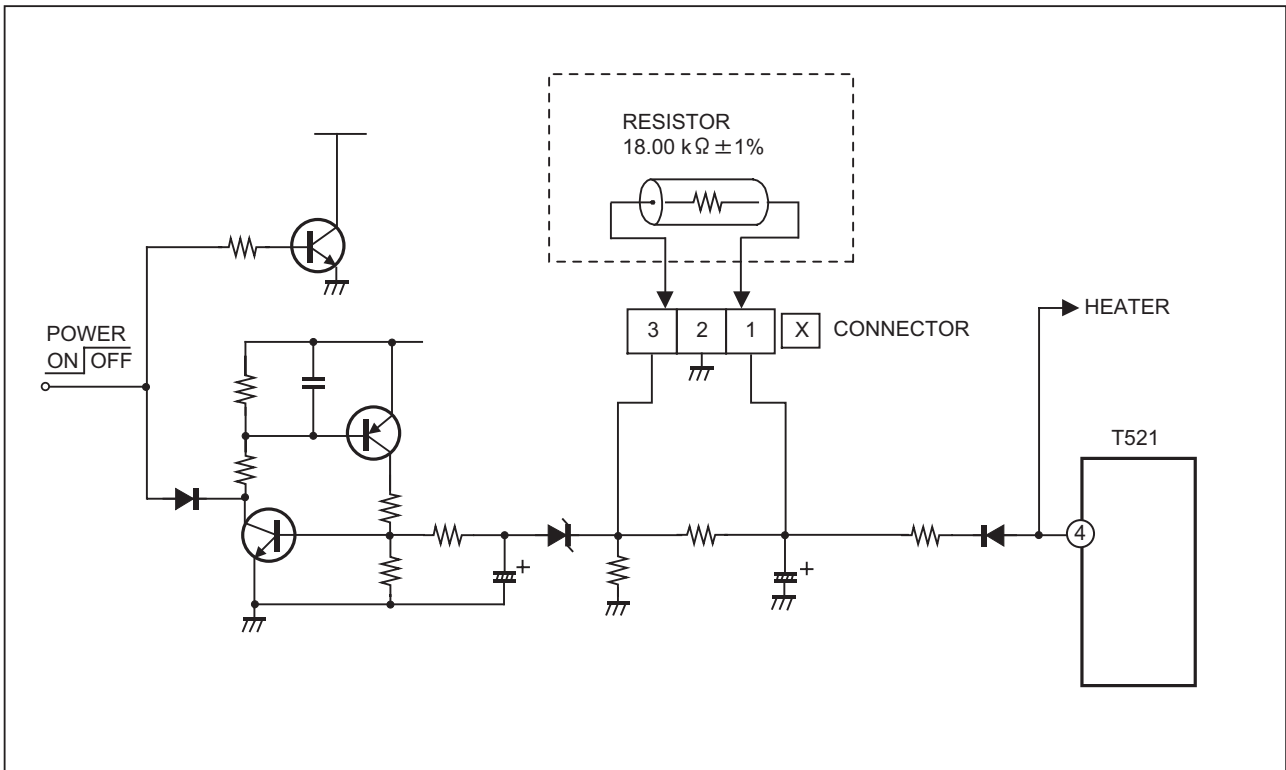



JVC

VICTOR COMPANY OF JAPAN, LIMITED
AV & MULTIMEDIA COMPANY DISPLAY CATEGORY 12, 3-chome, Moriya-cho, kanagawa-ku, Yokohama, kanagawa-prefecture, 221-8528, Japan